

368.1-21

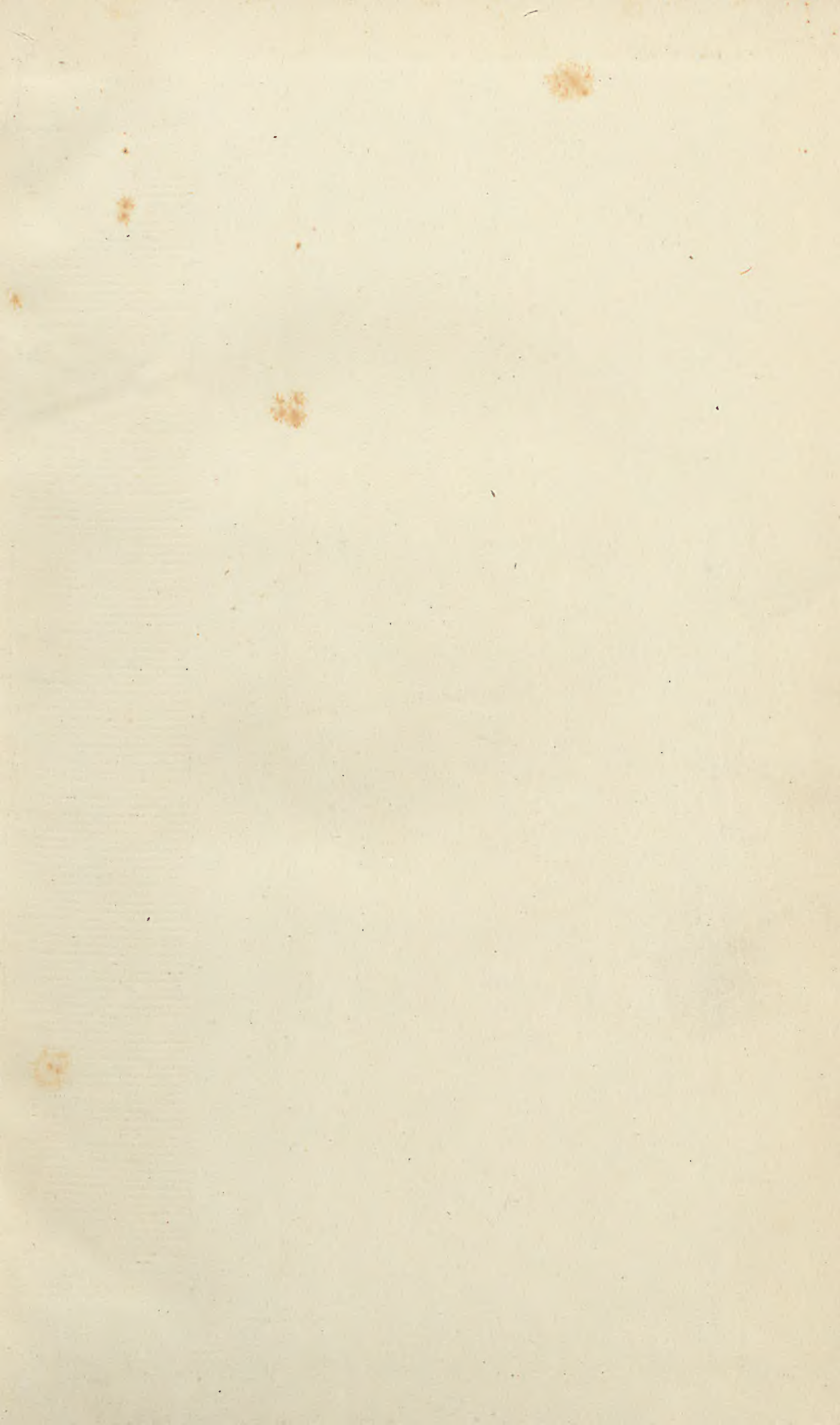

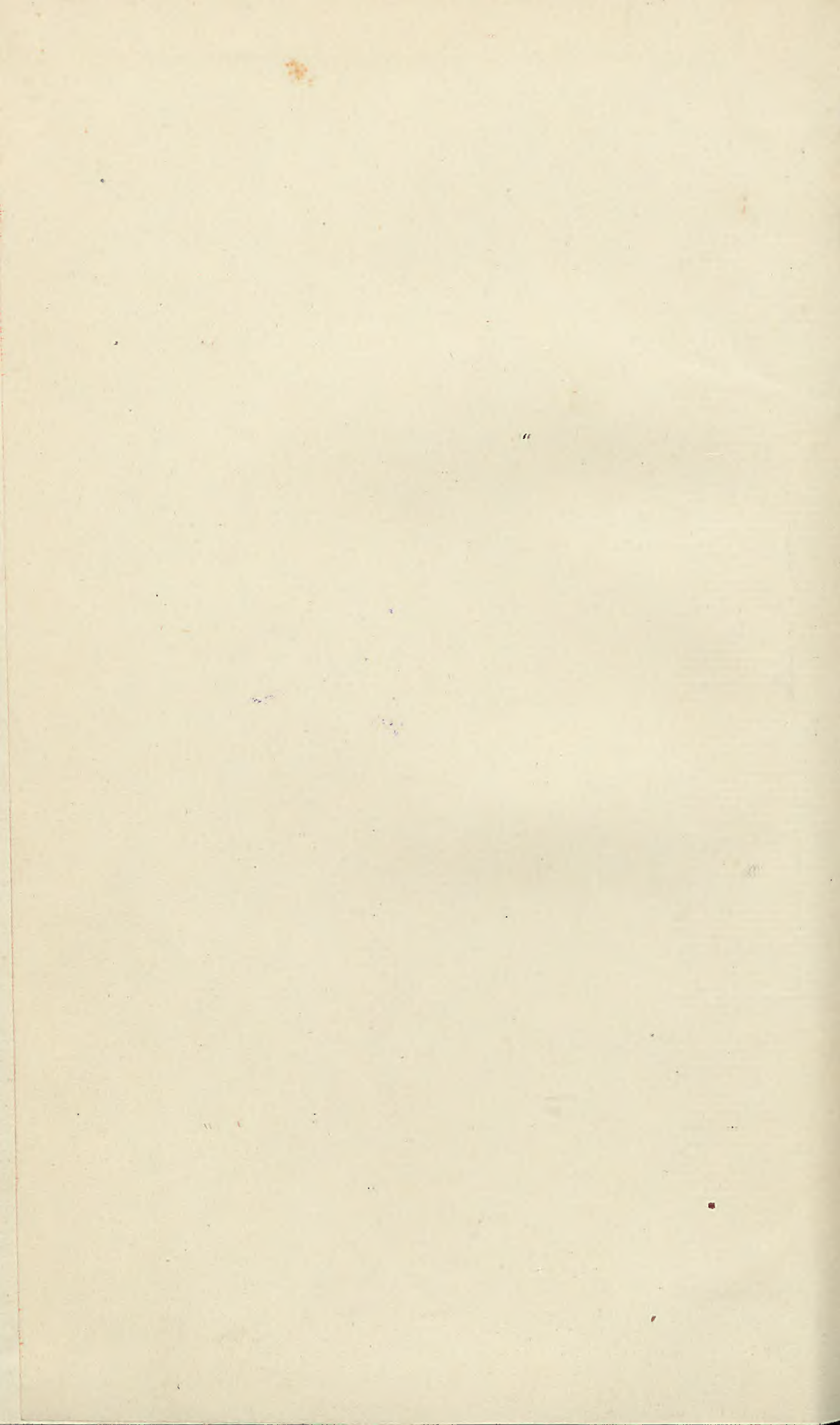



THE
QUEENSLAND AGRICULTURAL JOURNAL,

ISSUED BY DIRECTION OF

THE HON. THE SECRETARY FOR AGRICULTURE.

EDITED BY A. J. BOYD F.R.G.S.O.

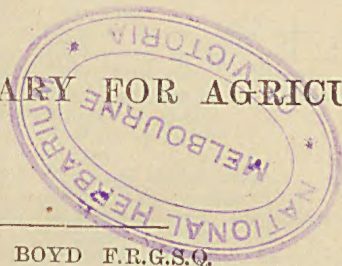

VOLUME XXI.

JULY TO DECEMBER, 1908.

BRISBANE:
BY AUTHORITY: ANTHONY J. CUMMING, ACTING GOVERNMENT PRINTER, WILLIAM STREET,

1908.

10

11

12
13
14
15
16
17
18
19
20

QUEENSLAND AGRICULTURAL JOURNAL.

VOL. XXI., PARTS 1-6.

GENERAL INDEX.

	Page.		Page.
A.			
A Jibbing Horse, To Cure	16	Banana Fibre	39
A Native Bird Destroying the Sparrow	254	Bananas, Queensland	19
A New Cane-cutting Machine	305	Bandicoots, Destroying	319
A New Hybrid Orange	68	Barn, To Measure Maize in the	35
A New Important Dwarf Rubber	190	Bee-keepers' Association, Queensland	170
A New Marigold	98	Bees and Fruit	220
A New Stumping Machine	253	Benzine, Nitre, &c.	54
A New Table Delicacy, "Mebos"	97	Biggenden Agricultural and Pastoral Society	318
A New Post-hole Digger	253	Bird, A Native, Destroying the Sparrow	254
A Seedless Tomato	98	Bird-scarer, A Successful	290
A Successful Bird-scarer	290	Birds, Preparing for Show	287
A Sweet-scented Dahlia	97	Breeding-place of the Codlin Moth	175
A £2,000 Hen	289	Bounty on Coffee	304
A 10-ton Silo	4	Bounty on Cotton	187
Abortion, Contagious	258	Botany	18, 292
Advantages and Disadvantages of Grading Cream	8	Breeds of Cattle, Judging	123
Agricultural College Ex-Students' Club - Dinner	152	British Appreciation of the "Journal"	115
Agriculture	1, 61, 107, 161, 211, 265	British Demand for Queensland Sisal Fibre	307
Ailing Horse	319	British Guiana, Sisal Hemp in	183
Alkali Lands, Utilising	5	Broom Millet	319
America, Improving the Tobacco Plant in	211	Buckwheat, Price of	257
Amount of Seeds required per Acre	174	Buffalo, The Australian	134
An Acre of Tobacco	54	Bunt or Stinking Smut of Wheat	273
Analyses of Manures	92	Butter Factories in Queensland	167
Angora Flocks in Queensland	125	By-product of Sugar-cane, Wax as a	306
Angora Goats	120, 125, 279	C.	
Animal Pathology	47, 93, 196, 245, 308	Cabbage Aphis	276
Annual Report of the Department of Agriculture and Stock	255	Cabbage, Red, Pickled	98
Answers to Correspondents 54, 100, 154, 204, 256, 319		Calabash Gourds and Pipes	244
Aphis, The Cabbage	276	Calves and Sheep, Stomach Worms in 93, 197	
Apiculture	170, 220, 301	Calves, Treatment of	279
Apples, Drying	183	Calving, Trouble after	319
Appreciation of the "Journal"	115	Can Plants See?	300
Arid Districts, Dry-farming in Semi-Artesian Water	148	Cane-cutting Machine, A New	305
Artificial Incubation by Electricity	17	Cane-fields, Destruction of Rats in	294
Ashes, Soot, and Coal	33	Cane-tops, Food Value of	154
Aitar of Roses	81, 212	Cape "Morgen"	35
August, Farm and Garden Notes for	59	Care of Horses' Hoofs	171
August, Orchard Notes for	57	Cassava	42
Australasian Wool Markets	107	Cassava, Fighting the Indian Famine with	242
Australian Buffalo	134	Cast-iron, Mending	53
B.			
Bacon Factories in Queensland	168	Cattle Dip	258
Bahamas, Sisal Hemp in the	304	Cattle, Guernsey	169
Bail and Gate for Milking Sheds	116	Cattle, Judging Breeds of	123
Banana Apple	97	Cattle Ticks and the Mongoose	20
		Ceylon, Coconuts in	318
		Change of Seeds	63
		Charlock, Destruction of	64
		Cheese Factories in Queensland	168
		Cheese Trade, The Gorgonzola	280
		Cheese, Small, To Make	165
		Chemistry	89, 92

	Page.		Page.
Chile Culture	340	Farm and Garden Notes	59, 104, 160, 210, 262, 324
Chinaman's Garden	1	Farming, Dry, in Semi-arid Districts ...	168
Cholera, Fowl	173	Farm Produce in the Brisbane Markets,	
Cigar Leaf	188	Prices for	56, 102, 157, 207, 261, 322
Clipping Horses	282	Farms, State	65
Coal, Ashes, and Soot	33	Feeding while Milking	10
Coccanuts	239, 303	Fibre, Banana	39
Coccanuts in Ceylon	318	Fibre Plant, The Zapupe	289
Codlin Moth, Breeding Place of the ...	175	Flies in the Dairy	301
Coffee, Bounty on	304	Flower Gardening	21, 77, 127, 179, 221, 295
Competition, Milking, at the National		Fodder Grasses	257
Association's Show, 1908	118	Fodder, Prickly Pear as	6, 61
Contributions to the Flora of Queensland	18, 292	Food Value of Cane-tops	154
Contagious Abortion in Cattle	258	Fourcroya Suckers, Poling of	88
Corns in Horses	216	Fowl Cholera	173
Correspondents, Answers to	54, 100, 154, 204, 256, 319	Fowls, Preparing for Show	287
Cotton, Bounty on	187	French System of Market Gardening ...	34
Cotton-growing	36	Fruit Market, The Southern... ..	55, 101, 156, 206, 260, 321
Cotton Market	52	Fruit, Prices for, in the Roma Street	
Cow with Congested Udder	154	Markets	55, 101, 156, 206, 260, 321
Cows, Device for Tying up, in Bails ...	69	Fruits, Queensland, in London	176
Cows' Teats, Warts on	258	Future of the Rubber Industry	302
Cream, Advantages and Disadvantages			
of Grading	8		
Cream Tests	258		
Cultivation of Pea-nuts	205		
Cultivation of Rubber	82		
		G.	
D.		Garden, The Chinaman's	1
Dahlia, A Sweet-scented	97	Garden, The School	30
Dairy Cattle, To make a Ration for ...	214	Gardening, Flower	21, 77, 127, 179, 221, 295
Dairy, Flies in the	301	Gardening, Market	34
Dairy Herd, Queensland Agricultural		General Notes	52, 97, 152, 203, 253, 318
College	8, 69, 116, 165, 213, 279	Goats, Angora	120, 125, 279
Dairying	8, 69, 116, 165, 213, 279	Good Roads	2
December, Farm and Garden Notes for	262	Gootie Method of Propagation	70
December, Orchard Notes for	263	Gorgonzala Cheese Trade	280
Department of Agriculture and Stock,		Grading Cream	8
Annual Report of the	255	Grasses, Fodder	257
Depasturing Wheatfields	211	Green Stuff, Weight per Acre	54
Desiccated Eggs	17	Ground Lime v. Ground Limestone ...	5
Destroying Bandicoots	319	Ground Nuts, The Cultivation of... ..	205
Destroying Heavy Timber	256	Growing Pineapples	204
Destruction of Charlock	64	Growing Tobacco in Sand	99
Destruction of Rats in Cane-fields ...	294	Growing Pumpkins in Dry Weather ...	97
Device for Tying up Cows in Bails ...	69	Guernsey Cattle	169
Dimensions of a Tomato Case	320		
Dip for 20 Cows	258	H.	
Dry-farming in Arid Districts	267	Hawaii, Labour and Irrigation on Sugar	
Drying Apples	183	Estates in	306
Dwarf Rubber, A New	190	Hawaii, Sisal Hemp in	282
		Hardy Rosella	20
E.		Hay, Estimating the Weight of	307
Eggs Desiccated	17	Hemp Industry of New Zealand	318
Electricity, Artificial Incubation by ...	17	Hen, A £2,000 White Orpington	289
Electrolysis in Reinforced Concrete ...	47	Hints on Growing Strawberries	73
Enoggera Sales 56, 102, 157, 207, 261,	322	Hog Skins, Tanning	203
Ensilage, Stack	277	Horse, A Jibbing, To Cure... ..	16
Erratum—Stomach Worms in Sheep ...	251	Horse, An Ailing	319
Esk Pastoral, Agricultural, and Indus-		Horse, Novel Method of Teaching to Trot	126
trial Association	317	Horses	13, 126, 171, 216, 281
Estimating the Weight of Hay	307	Horses, Clipping	232
Exhibition (1908), Results of Milking		Horses, Corns in	216
Competition at the	118	Horses' Hoofs, The Care of	171
Exhibition (1908), State Farm and Col-		Horses, Suffolk, Sale of	216
lege Exhibits at the	114	Horticulture	21, 77, 127, 179, 221, 295
Experiment Plots	35	Hybrid Orange, A New	68
Export, Poultry for	99		
Exporting Mangoes	219	I.	
		Imported Stallion, "King Edward" ...	172
F.		Improving the Tobacco Plant in America	211
Factories in Queensland, Butter	167	Incubation by Electricity	17
Factories, Condensed Milk, Cheese,		Indian Famine-fighting with Cassava ...	242
Bacon, and Meat Exporting	168	Industries Neglected... ..	42
		Industries, Tropical	36, 82, 188, 229, 302

	Page.
Inoculation of the Soil	278
Insect Pests in Poultry	286
Interesting Wheat-growing Experiments	278
Irrigation and Labour on Hawaiian Sugar Estates	306

J.

Jackson Potato Digger	161
Jerusalem Maize	271
John Chinaman's Garden	1
Judging Breeds of Cattle	123

L.

Labour and Irrigation on Hawaiian Sugar Estates	306
Lands, Alkali, Utilising	5
Leaf-blast of the Sisal Plant	244
Lime v. Limestone, Ground	5
Logan and Albert Agricultural and Pas- toral Society	255
London, Queensland Fruit in	176

M.

Maize, Jerusalem	271
Machine, A New Cane-cutting	305
Machine, A New Stumping... ..	253
Mangoes, Exporting	219
Manures, Analyses of	92
Manuring Tomatoes	319
Mare's Head, Swelling on	257
Mares, The Prophet's	18, 92
Market Gardening	34
Market Gardening, The French System of	34
Market, The Australasian Wool	107
Markets	55, 101, 156, 206, 260, 321
Marigold, A New	98
Measuring Maize in the Barn	35
Measuring Polo Ponies	217
"Mebos," A New Table Delicacy	97
Mending Cast-iron	53
Milk and Butter Competition at the Rockhampton Show, 1908	11
Milk Trade—Quality of Milk	124
Milking-sheds, Bail and Gate for	116
Milking whilst Feeding	10
Millet, Broom	319
Money in Waste Products	98
Mongoose and the Cattle Tick	20
More about the Suffolk Punch	13
Morgen, The German	35

N.

Neglected Industries	42
New Cane-cutting Machine	305
New Dwarf Rubber	190
New Hybrid Orange	68
New Marigold	98
New Stumping Machine	253
New Table Delicacy, "Mebos"	97
New Zealand Hemp Industry	318
Nitre, Benzine, &c.	54
Notes, Farm and Garden	59, 104, 160, 210, 262, 324
Notes, General	52, 97, 152, 203, 253, 318
Notes on the Presence of Two Stomach Worms in Calves	197
Notes, Orchard	57, 103, 158, 208, 263, 323
Novel Method of Teaching a Horse to Trot	126
November, Farm and Garden Notes for	210
November, Orchard Notes for	208

O.

	Page.
Oil Seeds, Prices of	257
On Ploughing	161
On the Selection of Phosphates	112
On Two Prickly Pear Affections	143
Orange, A New Hybrid	68
Orchard	19, 175, 219, 290
Orchard Notes	57, 103, 158, 208, 263, 323
Ostrich Farming	154

P.

Packing Vanillas for Export	238
Para Rubber-tapping... ..	82
Parasite of the Tick	300
Pathology, Animal	47, 93, 197, 245, 308
Philippines, School-gardening in the	27
Pigs, Weaning	213
Pigs, Wonderful Prices for	215
Phosphates, The Selection of	107
Pineapple-growing	204
Pineapple-growing in Singapore	215
Plants, Can they See?	300
Plants reputed Poisonous to Stock	89
Ploughing	161
Poling of Fourcroya Suckers	88
Polo Ponies, Measuring	217
Pony, The Welsh	126
Post-hole Digging Simplified	258
Potato-digger, The Jackson	161
Potato Seed, Sprouted	318
Poultry	17, 99, 100, 173, 283
Poultry for Export	99
Poultry, Insect Pests on	287
Preparing Birds for Show	287
Prices for Farm Produce in the Brisbane Markets	56, 102, 157, 207, 261, 322
Prices for Fruit in the Roma-street Markets	51, 101, 156, 206, 260, 321
Prickly Pear and Rabbits	125
Prickly Pear as Food for Stock	6, 61, 62
Prickly Pear, Spray for	356
Prickly Pear, Two Affections of the	143
Principles of Pruning	70
Prieto Sisal-scutching Machine	40
Propagation, The "Gootie" Method of	70
Prophet's Mares	18
Pruning, The Principles of	70
Pumpkins, Growing, in Dry Weather	97

Q.

Queensland Agricultural College Dairy Herd	8, 69, 116, 165, 213, 279
Queensland Beekeepers' Association	170, 220
Queensland Bananas	19
Queensland Fruits in London	176
Queensland Rainfall	45, 100, 142, 196, 252, 317
Queensland Sisal Fibre, British Demand for	307
Queensland, Southern, Sisal Hemp in	193
Queensland, Sugar-growing in	195

R.

Rabbits and Prickly Pear	125
Rainfall in the Agricultural Districts	45, 100, 142, 196, 252, 317
Raisin-making	172
Ramie, Manufacture of	234
Rats in Cane-fields, Destruction of	294
Rearing Turkeys	283
Red Pickled Cabbage	98
Redwater and Tick Fever	245

	Page.		Page
Reinforced Concrete, Electrolysis in ...	47		
Results of Milking Competition at the National Association's Exhibition, 1908	118		
Report on Methods Adopted for the Eradication of Cattle Ticks in the United States of America ...	47		
Rockhampton Show, Milk and Butter Competition at, 1908 ...	11		
Roads, Good ...	2		
Roma Street Markets, Prices of Fruit at the ...	55, 101, 156, 206, 260, 321		
Rosella, The Hardy ...	20		
Roses, Attar of ...	81, 212		
Rubber, A New Dwarf ...	190		
Rubber Industry, The Future of the ...	302		
Rubber, The Cultivation of, in Tropical Australia ...	82		
Rubber, Pará, Tapping ...	82		
S.			
Sales, Enoggera ...	56, 102, 157, 207, 261, 322		
Sand, Tobacco Grown in ...	99		
Sansivieria Region of Uganda ...	41		
Sawdust, The Use of, in Stables ...	281		
Scholars' Garden ...	30		
School-gardening in the Philippines ...	27		
Science ...	47, 148, 199		
Seed Potatoes, Sprouted ...	318		
Seedless Tomato ...	98		
Seeds, Amount of, Required per Acre ...	174		
Seeds, Change of ...	63		
Selection of Phosphates ...	112		
Sericulture ...	135, 184, 226		
Silkworms and How to Rear them ...	135, 184, 226		
Silo, A 10-ton ...	4		
Silos ...	265		
Singapore, Pineapple Cultivation in ...	215		
Sisal-cleaning Machine, "The Prieto" ...	41		
Sisal Fibre, British Demand for ...	307		
Sisal Fibre Decorticator ...	231		
Sisal Hemp at St. Helena ...	194		
Sisal Hemp in British Guiana ...	183		
Sisal Hemp in Hawaii ...	232		
Sisal Hemp in Southern Queensland ...	193		
Sisal Hemp in the Bahamas ...	304		
Sisal Hemp in German East Africa ...	229		
Sisal Plant, Leaf-blast of the ...	244		
Small Cheese, To make ...	165		
Soil Inoculation ...	278		
Soot and Coal Ashes ...	33		
South Burnett A. H. and I. Society ...	318		
Sparrow, A Native Bird Destroying the ...	254		
Speed and Stamina of the Welsh Pony ...	126		
Spray for Prickly Pear ...	356		
Stables, The Use of Sawdust in ...	281		
Stack Ensilage ...	277		
State Farm and College Exhibits at the National Association Show, 1908 ...	114		
State Farms ...	65		
Stallion Tax ...	105		
Stallion, "King Edward," Imported ...	172		
Statistics ...	45, 100, 135, 196, 252, 317		
Stinking Smut or Bunt ...	273		
Stock, Plants Reputed Poisonous to ...	89		
Stock, Prickly Pear as Fodder for ...	6, 61, 62		
Stomach or Wire-worms in Sheep and Calves ...	93, 197, 205		
Strawberries, Hints on Growing ...	73		
Stumping Machine, A New ...	253		
Suffolk Horses, Sale of ...	216		
Suffolk Punch, More about the ...	172		
Sugar-cane, Wax as a By-product of ...	306		
Sugar-growing in Queensland ...	195		
Sunrise and Sunset ...	51, 99, 155, 178, 259, 320		
Sweet-scented Dahlia ...	97		
Swelling on Mare's Head ...	257		
		T.	
Tanning Hogskins ...	205		
Tapping Pará Rubber ...	82		
Tax, A Stallion ...	205		
Teaching a Horse to Trot, A Novel Method of ...	126		
Ten-ton Silo ...	4		
The Australian Buffalo ...	134		
The Banana Apple ...	97		
The Cape "Morgen" ...	35		
The Cocoa-nut ...	239		
The Jackson Potato-digger ...	161		
The French System of Market Gardening ...	34		
The Future of the Rubber Industry ...	302		
The Hardy Rosella ...	20		
The Horse ...	13, 126, 171, 216, 281		
The "Prieto" Sisal cleaning Machine ...	41		
The Prophet's Mares ...	18		
The Sansivieria Region of Uganda ...	41		
The So-called Wonder Grass ...	18		
The Suffolk Punch, More About ...	13		
Tick Fever or Redwater ...	245		
Tick Parasite ...	300		
Ticks, Report on the Methods adopted for their Eradication in the United States of America ...	47		
Ticks and the Mongoose ...	20		
Timber, Heavy, Destroying ...	256		
Times of Sunrise and Sunset ...	51, 99, 155, 178, 259, 320		
Tobacco, An Acre of ...	54		
Tobacco, Growing, in Sand ...	99		
Tobacco Plant, Improving, in America ...	211		
To Cure a Jibbing Horse ...	16		
To Make Small Cheese ...	165		
To Make up a Ration for a Dairy Cow ...	214		
To Measure Maize in the Barn ...	35		
Tomato, A Seedless ...	98		
Tomato Case, Dimensions of a ...	320		
Tomatoes, Manuring ...	319		
Treatment of Calves ...	279		
Tropical Australia, The Cultivation of Rubber in ...	82		
Tropical Industries ...	36, 82, 188, 229, 302		
Trouble after Calving ...	310		
Turkeys, Rearing ...	283		
Tying up Cows in Bails, Device for ...	69		
U.			
Uganda, The Sansivieria Region of ...	41		
Use of Sawdust in Stables ...	281		
Utilising Alkali Lands ...	5		
V.			
Vanillas, Packing, for Export ...	238		
Vegetable Pathology—Two Prickly Pear Affections ...	143		
W.			
Warts on Cows' Teats ...	258		
Waste Products, Money in ...	98		
Water, Artesian ...	148		
Water-finding ...	199		
Wax as a By-product of Sugar-cane ...	306		
Weaning Pigs ...	213		
Weight of Hay, Estimating ...	307		
Weight of Green Stuff per Acre ...	54		
Welsh Pony, Speed and Stamina of the ...	126		
Wheat, Bunt or Stinking Smut of ...	273		
What can be done with Banana Fibre ...	39		
Wheat-fields, Depasturing ...	211		
Wheat-growing Experiment ...	278		
Wonder Grass, The So-called ...	118		
Wool Market, The Australasian ...	107		
Worms, Stomach, in Sheep and Calves ...	93, 205		
Z.			
Zapupe Fibre Plant ...	289		

Agriculture.

JOHN CHINAMAN, GARDENER.

It goes without saying that the European market gardener who understands his business, and devotes himself earnestly to it, can raise a greater variety of vegetables, and of infinitely better quality, than the Chinaman gardener. It was out of market gardening that Kubelik, the great violinist, made the money which enabled him to become a celebrated artist, and an exceedingly wealthy man. Why is it that we so rarely see a purely white man's market garden? We give it up. Vegetables grow to perfection all the year round in Queensland. The soil is unsurpassed in the world. Water is plentiful, or can be made so, yet the white farmer contents himself with a possible profit of less than £2 per acre on wheat, and proportionately small profits on maize, pumpkins, potatoes, &c., whilst the Chinaman forces ten times that amount per annum out of a small hand-worked vegetable garden.

His methods are described as follows by a writer in the "Rural Californian" :—

For the past three years it has been my pleasure and privilege to observe the methods of a Chinese gardener near by, and humbly imitate his procedures in my own modest "truck patch."

Although in his own country "John" was a water-carrier by occupation, he has during his few years' sojourn here acquired a store of agricultural lore calculated to inspire his neighbours with envious admiration.

For example, when his young lettuce reaches the height of 2 or 3 inches, he does not eat or throw away the young plants in the process of thinning. Instead, he clips off about an inch of the root tip, and replants them in long rows, placing the plants at least a foot apart. This transplanted lettuce forms heads of such an immense size that at a short distance the bed resembles a cabbage patch.

His onions, which he always grows from the seed, disdaining the use of cloves or sets, have their roots clipped when transplanted, and grow to be larger than an ordinary saucer in an incredibly short time. He transplants beets in precisely the same manner as the lettuce and onions.

When he cuts off the lettuce heads for market he waters and cultivates the bare stalk, which heads out again in about one-third the time required to grow it from the seed. He treats his cabbages in the same way, except that he allows the outside leaves to remain attached to the stalk. The second head is small, and has no white centre, but he finds a ready market for it among the lovers of boiled greens.

"John" saves his pumpkins and squash seeds by leaving them inside the pumpkin or squash, as the case may be, until the planting season. Then he opens the aforementioned vegetables, and plants the seeds with the fresh pulp clinging to them.

He wraps his muskmelon seed in a tow sack and buries them in rich soil, keeping them very moist during the few days which pass before the seeds sprout. He then plants them, and they appear above the ground with mushroom-like rapidity.

Once, contrary to his advice, I set tomato plants on a spot where ashes had been thrown for several years. The vines grew to an enormous size, and had many blossoms, which dropped off in a few days. One day "John"

observed this, and with great solemnity came over and cut and hacked the branches of the plants almost half in two. Although this was in the latter part of July, the drooping, half-severed vines were soon loaded with tomatoes, and continued to bear until killed by frost in December.

GOOD ROADS.

We have from time to time published several excellent articles by the Hon. A. J. Thynne, M.L.C., on the subject of road-making, but rural authorities still adhere to the old practice of cleaning out the water-tables and heaping up a mass of grass, weeds, and mud in the centre of the road, in some cases putting on a blinding of gravel mixed with large stones. The roads beyond Mount Gravatt are excellent examples of this style of work. Such a road quickly degenerates into deep water- and wheel-worn ruts, but as these are never filled in till the road becomes almost impassable, it might just as well have been left alone.

Few of our country roads are macadamised—probably 90 per cent. are mere dirt roads. Can these dirt roads be rendered permanently sound? A United States farmer, Mr. D. Ward King, shows us how this can be effected for a mere song, by means of the log drag, which is described as follows:—

Following is a diagram of the drag with an explanation:

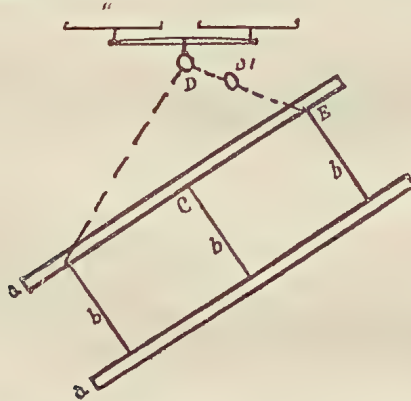

In this diagram *a, a*, are the two halves of a split log 9 feet long, 10 to 12 inches thick, set on edge, 30 inches apart, both flat sides to the front; *b, b*, strong oak or hedge bars, the ends of which are wedged in 2-inch auger-holes bored through the slabs; dotted line, chains or strong wire. *D, D1*, are rings to connect double-tree clevis. Hitch at *D* and stand at *C*, on a plank laid on the cross-bars, for ordinary work; or hitch at *D1* and stand at *E* for ditch-cleaning or to make the drag throw more dirt to the left. To move dirt to the right reverse position of driver and hitch. If working a clay or gumbo road, put iron, old wagon-tire, or something of the sort, on lower edge of drag at end of six months; for softer soil at the end of twelve months.

Relating his first experiment, Mr. King said:—

The horses were attached at such a point of the wire as to give the drag a slant of about 45 degrees in the direction required to force the earth that it would gather from the side of the road up into the centre. We had just had a soaking rain, and the earth was in a plastic condition. I had driven this drag but a few rods when I was fully aware that it was serving at least the initial purpose for which it was intended—that of levelling down the wheel rut and pushing the surplus dirt into the centre of the road.

At my neighbour's gate, towards town, I turned around and took the other side of the road back to my home. The result was simply astonishing. More rain fell upon this road, but it "ran off like water from a duck's back." From that time forward, after every rain or wet spell, I dragged the half-mile of the road covered by my original experiment.

At the end of three months the road was better than when it had been dragged for three weeks, and at the end of three years it was immensely improved over its condition at the end of the first year's work. I studied the result of each step in my experiment, and finally learned that three elements are required to make a perfect earth road, and that the lack of any one of them is fatal to the result. To be perfect an earth road must be at one and the same time oval, hard and smooth. All of these indispensables are acquired by the use of the split-log drag in any soil that I have ever come in contact with—and I have worked in the various kinds of clay soil in the gumbo of the swampy lowlands and in the black mud of the prairies.

Observation of my experiment taught me that two weeks of rain would not put this bit of road in bad condition at a time when the highway at either end of it was impassable for a wagon. Of course, it was plain that the reason the road was not bad was that there was no mud in it. But why mud would not collect in it was not clear to me until I was taught my lesson by the very humble means of the hog wallow. One day I chanced to notice that water was standing in one of these wallows long after the ground all about it had become dry. Probably I had many times before observed this fact, but not until now had it occurred to me to inquire into its cause. Examining the edges of the wallow, I was impressed with the fact that it was almost as hard as a piece of earthenware. Clearly this was because the wallowing of the hogs had mixed or "puddled" the earth and the water together, forming a kind of cement, which dried into a hard and practically waterproof surface.

The next important lesson in my understanding of the real elements of road-making was taught me by studying what we farmers call a "spouty spot" in the side of a clay hill. All who live in a clay country know the unspeakable stickiness of one of these spouty places, and are familiar with the fact that, after ten days or two weeks of bright, hot sunshine, you can take an axe and break from one of these spots a clod so hard that with it you can almost drive a ten-penny nail into a pine plank. Naturally, it occurred to me that, if this puddled clay soil would stay hard for three months when left in a rough condition, it would surely stay longer if moulded into the form of a smooth roof, so that the water which fell upon it would easily run off.

This original half-mile of road was dragged steadily for four years before I had a single active recruit in my new crusade. At first my neighbours poked good-natured fun at me, probably because the thing was so new and so absurdly simple—and, perhaps, also, because I did the work without pay or any expectation of it. Road-making in the country, it may be well to explain, is not generally followed as a fashionable philanthropy or a popular diversion.

From the outset of this work, so many questions have poured in upon me indicating points concerning which the public is prone to go astray in its understanding of how to build and use the split-log drag, that I have prepared the following road-dragging "catechism" as covering, with fair completeness, the main working facts in the problem:—

Would it not be better to plough the road before dragging? No. Ploughing gives a soft foundation. Ploughing the middle of the road is a relic of the old dump-scraper days.

What do you do when there are deep ruts in the road? Drag them. If you drag when the surface is quite loose and soft, you will be surprised how soon the ruts disappear.

How do you get the dirt to the middle of the road? By hauling the drag siantwise with the end that is toward the centre of the road a little to the rear of the other end.

But suppose the road is too narrow? First drag the wheel tracks. After three or four rains or wet spells, plough a shallow furrow just outside the dragged part. Spread this over the road with a drag. Only plough one furrow. You may plough another furrow after the next rain. At each ploughing you widen the road bed 2 feet.

How many horses do you use? Two, generally; three if it is just as handy; four when breaking colts—a good solid team in the centre and a colt on each side; two men on the drag—one to drive, the other to control the colts.

How do you drain the road? If the earth is pushed in the middle of the road continually, the road will drain itself.

Why not make the drag out of plank? You can, and do good work. But the split log is best. The plank drag is not so stiff.

Why not make the drag of heavy sawn timber? Because drags so made have a tendency to slip over the bumps.

Don't you grade up the road first? No. The grading is done with the drag gradually. By so doing, the road is solid all the time, and is built on a solid foundation.

What does it cost to drag a mile of road a year? The cost is variously estimated at from one to three dollars.

How do you keep the drag from dodging around sidewise? By not loading it too heavily. If a drag dodges around the earth you are moving, it is because it is overloaded.

Will the dragged road stand heavy hauling? Yes and no. A dragged road will stand more heavy hauling than an undragged road, but not so much as a macadamised or well-kept gravel road.

Will a drag help a sand road? A sand road is a very different proposition from the black soil, clay, or gumbo. An entirely different method must be adopted. Three things may be done to a sand road to make it better: First, keep it wet; second, haul clay on to it; third, sprinkle it with crude oil, as they do in California and in some parts of Southern Kansas and Texas. The drag will be beneficial in keeping the sand road perfectly flat, so that it will absorb moisture and retain it a long time.

To this catechism I would add the following "Don'ts": Don't drive too fast. Don't walk; get on the drag and ride. Don't be particular about material; almost any log will do. Don't try to drag with only one piece; use two.

A 10-TON SILO:

In response to the request of a Gladstone farmer, we here describe and illustrate a cheap silo, having a capacity of 10 tons, which can be erected at an approximate cost of from £25 to £30. The plan was prepared by Mr. A. Morry, who has already given plans, details, and estimates of silos of larger dimensions in late issues of the Journal, and from these the details of the small silo may be worked out. By using malthoid lining, there is no occasion at first for an acid-proof dressing, as the material itself is treated in process of manufacture with an acid-proof substance. Later on, it would be an advantage to dress the malthoid lining with a composition obtainable from the agents, the New Zealand Loan and Mercantile Agency Company, Brisbane. The Agricultural Department has used carbon-elastic paint for dressing galvanised iron to prevent the action of acids and weather, but it has not yet had an exhaustive trial, so nothing definite can be given.

Plate I.

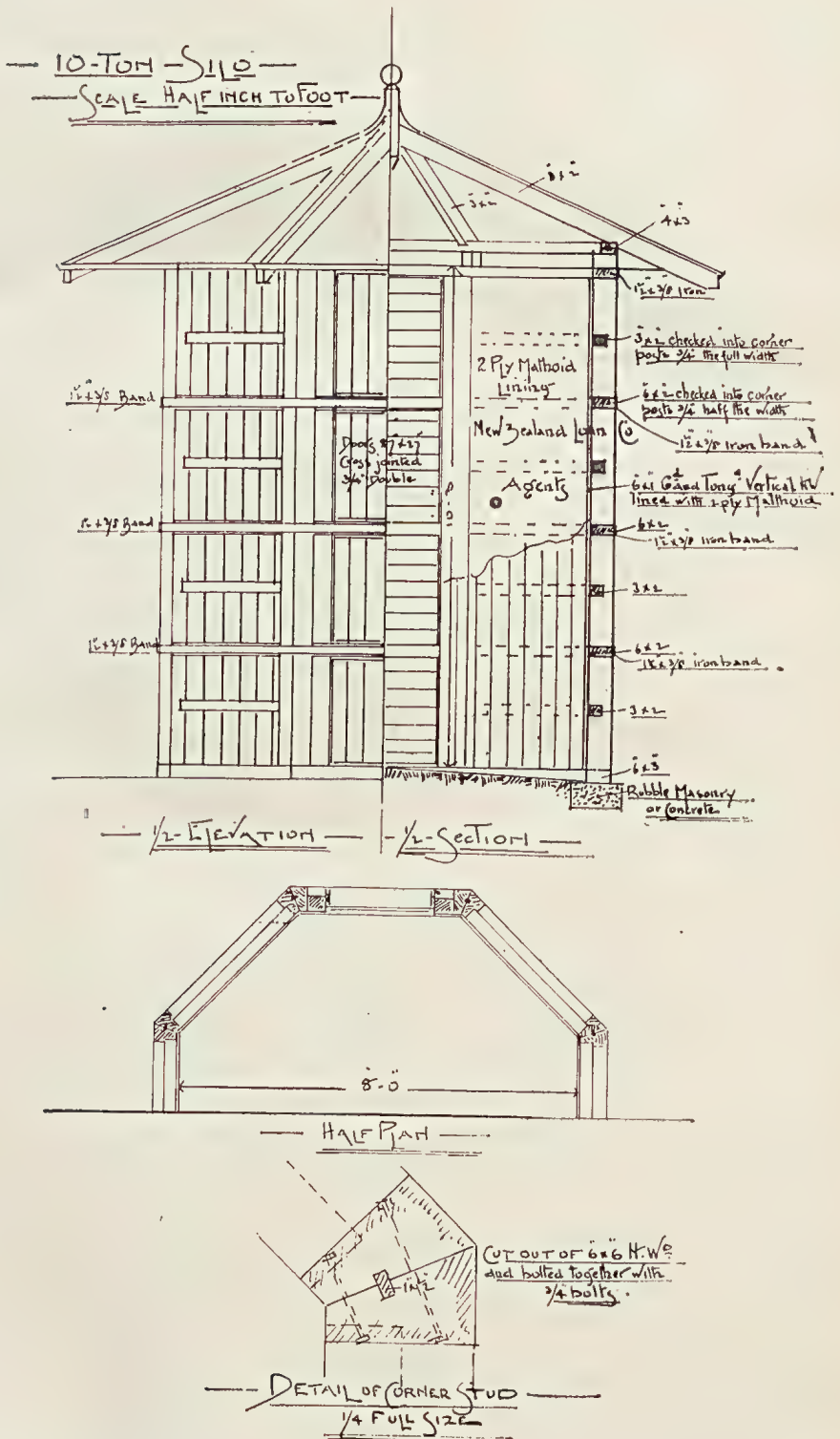

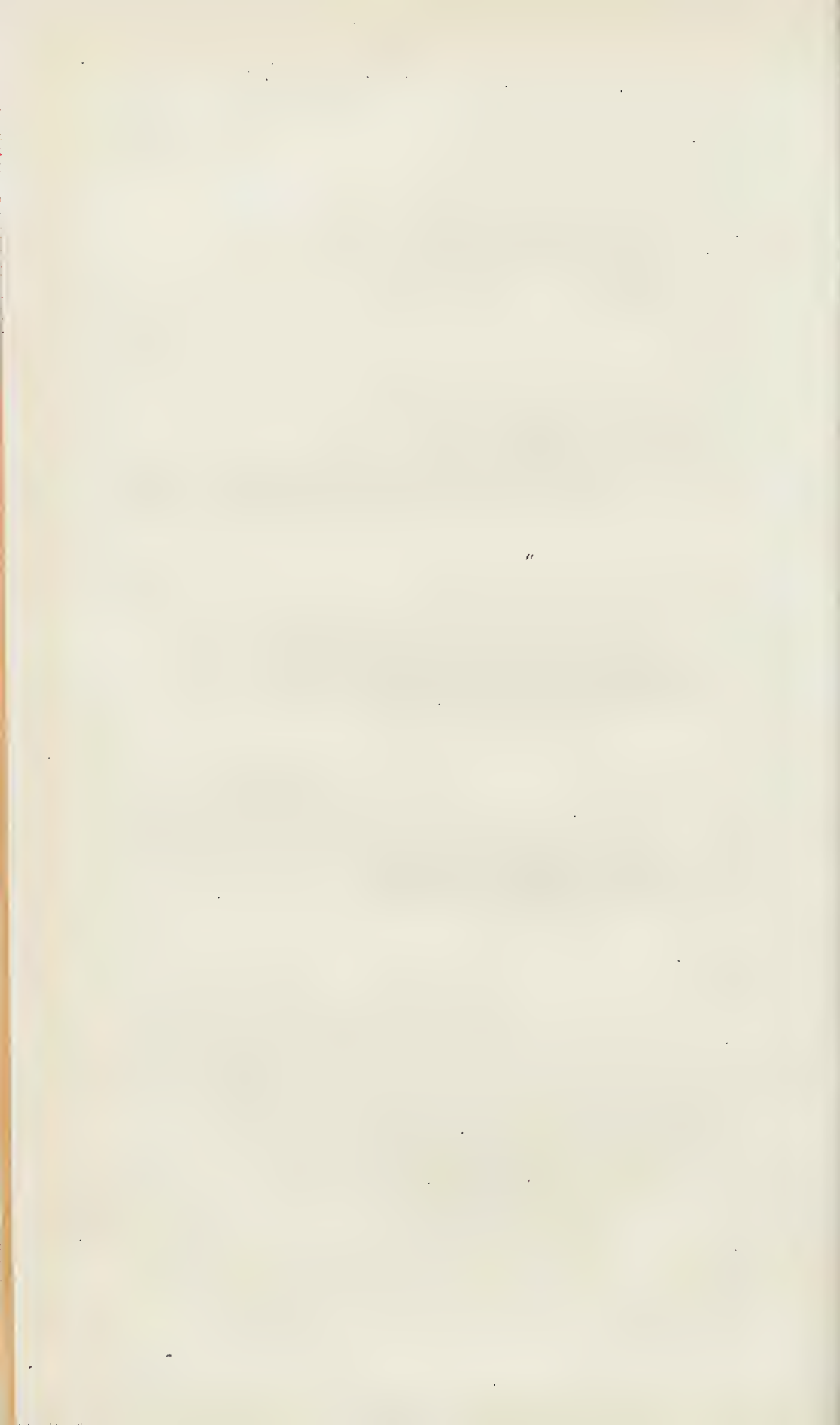

UTILISING ALKALI PATCHES.

In some parts of the State there are, in the midst of the rich fertile black soil lands, patches of alkali soil, on which it was once believed that nothing would thrive. Such isolated areas existed on lands near Warwick, and the manager of the State farm, the Hermitage—then Mr. Chas. Ross, now managing Westbrook State Farm—set to work to remedy the evil. His experiments met with complete success, and yet the remedy was so simple that it is remarkable nobody had thought of it before. He knew that there were certain plants which could absorb a large amount of alkali, and especially amongst them he included mangolds and the silver beet. These grew to perfection on the alkali patches, and removed so much of the salt that in time the land was rendered fit for wheat, lucerne, and other grasses. Lucerne, it was found, also thrives on the alkali after mangolds, or at once, provided the surface be fairly free from alkali. Under such conditions the seed germinated, and the roots made their way to a considerable depth below the alkali strata, and thence drew ample nourishment for the plant. On the other hand, whilst magnificent cabbages, cauliflowers, and other vegetables were grown on the farm, they were a failure on the alkaline spots, as were all other legumes. It is said that asparagus will do well on such land, being alkali-resistant. This plant was, we believe, not experimented with.

GROUND LIME *VERSUS* GROUND LIMESTONE.

In recent years the once common practice of applying heavy dressings of quicklime to the soil has fallen into disuse. The idea underlying that practice was to make provision against "lime-hunger" for a good many years. But if there be one thing which has been more clearly proved than another by the agricultural experiments of recent years, it is the fact that heavy dressings of quicklime were unprofitable. For one thing, the quicklime, when applied in large quantities, killed off a large proportion of the nitrifying and other advantageous soil bacteria. For another thing, lime sinks rapidly in the soil, and through the action of rain water it is carried into the drains or the subsoil, so that, as a rule, it is soon beyond the reach of the plants. In recent years the much more rational plan of applying small dressings of ground quicklime has been introduced, and has generally given very satisfactory results, particularly in soils which were rich in organic matter. This ground quicklime was applied in dressings of up to 20 cwt. per acre, and this small quantity was readily utilised by the soil bacteria for the use of the growing crop. Lime is an essential element of plant food, and every crop grown on any soil removes more or less lime from that soil. In the case of soils infected with the germ of the finger-and-toe disease, the ground quicklime, which can be very equally distributed over the soil, may be used to kill these malign germs, and induce a healthy growth of crop, particularly when the lime is buttressed with potash, and no acid manures are used in dressing the soil. It is a curious fact, however, that quicklime, whether ground or in the "shell" form, is produced from limestone—a hard rock in which the carbon dioxide of composition is driven off by burning, and that the quicklime, on being exposed to the air, absorbs this same gas, and is again converted to carbonate of lime. These facts have raised the question as to whether the ground limestone rock might not be ground to a fine state of division and applied to the soil just as quicklime is. This question has been dealt with experimentally by the staff of the Lancashire County Council, who have issued a report of experiments on the subject by Mr. Edward Porter, B.Sc., and Mr. R. C. Gaut, B.Sc. The report states that quicklime in the "shell" form and also in the form of ground

lime were tested against limestone which had been ground to a fine state of division. Quicklime, on reabsorbing the carbon dioxide and reverting to the carbonate form, increases greatly in bulk, so that 1 ton of it will weigh when completely converted into carbonate of lime, $1\frac{3}{4}$ ton. One ton of "shell" lime, therefore, was tested against 1 ton of ground lime, and also against $1\frac{3}{4}$ ton of ground limestone, while a "no-lime" plot was kept for "control" purposes. These tests were carried out on four different farms, and the results were singularly uniform, the balance being decidedly in favour of ground lime as compared with shell lime, and rather decidedly also in favour of the $1\frac{3}{4}$ ton of ground limestone as against the 1 ton of ground lime. The difference in price was also in favour of the ground limestone, as the 1 ton of "shell" lime cost 14s. 2d., the 1 ton of ground lime cost 22s. 2d., while the $1\frac{3}{4}$ ton of ground limestone only cost 13s. 8d. Alike, as regards both price and produce, therefore, the balance was in favour of the ground limestone, which has the further advantage that it has no irritating effects on the eyes and the nose, and drops to the ground more readily than ground lime from a mechanical sower. If these results are confirmed by further experiments on a large scale, it seems more than likely that the use of limestone ground to a fine powder will make rapid headway in the favour of agriculturists.—"Agricultural Gazette," Tasmania.

PRICKLY PEAR AS FOOD FOR STOCK.

The importance of the question, How to deal with the prickly pear in Queensland? cannot be over-estimated. Already large sums have been expended by the Department of Agriculture and Stock, as well as by private land-owners, in the endeavour to eradicate the pest, but without avail. Still, considerable areas of prickly pear infested land have been taken up by selectors, and are gradually being brought under cultivation or turned into useful pasture land. By the courtesy of Mr. Sydney Dodd, Chief Veterinary Surgeon and Bacteriologist to the Department, we have been furnished with a pamphlet issued by the United States Department of Agriculture (Bureau of Plant Industry, Bulletin No. 74), a perusal of which would lead to the conclusion that by a certain method of treatment the pear may prove to be a blessing instead of the reverse in the semi-arid districts of the State. This pamphlet has reached us too late to enable us to give more than a general outline of its features in this issue of the Journal, but next month we shall make copious extracts, accompanied by several illustrations, showing the methods of treatment by which the plant is turned to good account as a food for stock. Were it not for the formidable prickles with which the leaves and joints bristle, there would to-day probably not be a single plant on our Western lands. During the great drought which terminated in 1902, the starving stock would have lived upon it, obtaining fodder and drink which would have saved thousands of the cattle which then died of starvation. Indeed, many were saved by being fed with the pear when steamed, but this was a too laborious and expensive business to be generally adopted.

SINGEING THE SPINES.

For the greatest progress in this line, we must see what has been done in Texas, U.S.A., and also in Mexico. There the plants were, and are to-day, collected and hauled to some convenient place, where a fire is built. The fire quickly destroys the spines, leaving a succulent fodder, which cattle devour with impunity. This is the most primitive method of utilising the plant.

SINGEING WITH A TORCH.

A vast improvement on the above plan was that of singeing with a torch for removing the spines. The process consists in passing a hot-blast flame

over the surface of the plant, which can be quickly done, at small expense, since the spines are dry and inflammable, and the more spines the better they burn, and even the application of a match to the lower part of the trunk will destroy them. The instrument used for the purpose is a modified plumber's torch. Any other convenient torch which gives a good flame can be employed, and the innermost parts of the plant can be reached by the flame.

These pear-burners were first manufactured in 1898. They consist of a strong metal tank supported on the shoulders of the operator by a strap, a long delivery pipe, and a burner for generating and consuming gas from gasoline. The distinguishing features of one of the pear-burners on the market are the turning joints of the delivery pipe and the simple coiled-pipe burner, which is covered with a sheet-iron cylinder to prevent the escape of heat, to give direction to the flame, and to protect the burner in windy weather.

The other style of burner differs from the one just described mainly in the burner, which is somewhat more complicated. The generated gas in this machine passes through a chamber filled with a bundle of fine brass wires before being ignited. It also has some safety arrangements for ensuring the heating of the oil, and consequent generation of gas, which are claimed to have merit.

Both machines require gasoline for their operation, and are handled to best advantage with a good quality of oil, and in weather free from wind.

Practically no labour is necessary with the burners other than that of passing the blast flame from the torch over the surface of the joints momentarily. Indeed, it is not usually necessary to do this with over two-thirds of the plant, for there is, commonly, enough dead herbage at the base and growing up through the pear plants to assist in burning off at least one-half of the spines. This is the cheapest method yet devised for utilising the prickly pear. It has, however, one or two disadvantages. There is a prejudice—whether well founded or not, it has been impossible to determine—against pear scorched to the extent necessary to ensure the destruction of all the small spines. It is claimed that cattle scour much worse upon pear which has been excessively scorched by either torch or brush flame. Another objection urged is that torch-scorched pear invariably dies if the flame is kept upon it long enough to ensure the removal of all the spines. This is really an important matter for those who have little pear in their pastures, as simply singeing off the larger spines does not check the growth of the plant at all, and all the singed plants not actually grazed grow the following season.

[The dying off of torch-singed plants would certainly be no objection to the process in Queensland.—Ed. "Q.A.J."]

Burning with a pear-burner will kill out the pear entirely if close pasturing is practised afterwards.

We shall, in the next issue of the Journal, deal more extensively with the subject of the destruction of the pear by means of the torch apparatus, and with the value of the plant as a fodder for stock.

So much importance is attached to the prickly pear in Texas that some cattle-owners actually plant the cactus instead of destroying it, and it is there held that the occasion for the destruction of the pear does not exist, and that an absolute destruction would be a calamity indeed.

Dairying.

THE DAIRY HERD, QUEENSLAND AGRICULTURAL COLLEGE,
GATTON.

RECORD OF COWS FOR MONTH OF MAY, 1908.

Number.	Cow's Name.	Breed.	Date of Calving.	Total	Average	Commer-	Remarks.
				Milk.	Test,	cial	
				Lb.	Per cent.	Butter.	
1	Rhoda ...	Grade-Shorthorn	30 Mar., 1908	819	3·7	33·93	
2	Hettie ...	" "	26 Mar. "	660	4·2	31·04	
3	Winnie ...	Shorthorn	15 April "	737	3·7	30·54	
4	Carrie ...	Jersey ...	4 April "	643	3·8	27·36	
5	Glen ...	Shorthorn	10 Feb. "	551	4·1	25·30	
6	Mona ...	Grade-Holstein	26 Oct., 1907	475	4·5	23·94	
7	Nancy ...	Shorthorn	7 May, 1908	517	3·9	22·58	First calf.
8	Damsel ...	Holstein ...	19 Feb. "	588	3·3	21·73	
9	Cuckoo ...	Jersey ...	4 Mar. "	444	4·3	21·38	
10	Nellie II. ...	Shorthorn	26 Dec., 1907	454	3·8	19·32	
11	Cocoon ...	Jersey ...	20 Nov. "	380	4·5	19·15	
12	Ivy ...	" "	5 Feb., 1908	362	4·6	18·65	
13	Laura ...	Ayrshire	20 May, 1907	384	4·3	18·49	
14	Beauty ...	" "	21 Dec. "	485	3·4	18·46	
15	Lucy II. ...	Shorthorn	1 May, 1908	456	3·5	17·87	
16	Comet ...	Grade Holstein	23 Aug., 1907	307	5·2	17·87	
17	Careless ...	Jersey ...	29 Oct. "	315	5·0	17·64	
18	Clare ...	" "	21 Aug. "	289	5·4	17·47	
19	College Lass	Ayrshire...	1 Sept. "	329	4·7	17·31	
20	Honeycomb	Shorthorn	23 Aug. "	327	4·7	17·21	
21	No. 112 ...	Grade Jersey	23 Aug. "	356	4·3	17·14	
22	Lily... ...	Ayrshire	2 May, 1908	476	3·3	17·59	
23	Dot ...	Shorthorn	20 Aug., 1907	329	4·5	16·58	
24	Graceful ...	" "	11 Jan., 1908	299	4·8	16·06	

ADVANTAGES AND DISADVANTAGES OF GRADING CREAM.

The following paper, which was read by a farmer before a Manitoba (Canada) Dairy Association, will no doubt be read with interest by dairy farmers and factory managers, seeing that it touches points which have already received attention by them in Queensland:—

ADVANTAGES AND DISADVANTAGES OF GRADING CREAM-

(Paper read before the Convention of the Manitoba Dairy Association by Geo. Mattheson, Shellmouth, Manitoba.)

The subject of grading cream has been more discussed during the past few years. Some years since it was put upon trial by one of the larger creameries in the American West with signal success. Since that time the system has spread—slowly, it is true—and at the present time the subject is a live one. It is discussed wherever creamery men meet, and has been the medium of proposed reform by the dairy departments of more than one State. The compulsory use of cream-grading has even been hinted at.

Cream-grading has, of course, its advantages and disadvantages. I shall enumerate a few of them. The advantages—first, the cream producer is paid according to the quality of his cream, or, if you like, according to the quality of the intelligence and of the labour which he puts into the task of cream-producing. Is it not fair that the man who takes good care of his cows, milks them in a cleanly manner, separates the milk in the right way and at the

proper time, and, lastly, cools the cream immediately, and keeps it cool until it is delivered to the creamery, is it not just and equitable that such a man should receive a better price than his neighbour who is careless, heedless, and negligent? Which of them is of the greater value to the creamery? Is not the former taking a part, however small or insignificant, in improving the dairy products of his province, and may it not be said that he is a better citizen? The dairyman ought to receive pay according to the quality of his labour.

It may also be said that grading cream will enable the butter-maker to turn out a higher average grade of butter, commanding a better price. In every line of endeavour the best sells for the highest, and the poorest for the lowest price, and this is true whether this article in question is grain, live stock, or produce. We have been told time and again that the quality of our butter is far from what might be desired, what the faults are and how they can be remedied; but unless there is some monetary inducement offered to the producer of cream, I do not know that we are likely to make much headway. What someone has called the campaign of "please be clean" is a discouraging and almost hopeless task, and I do not think will avail much unless it can be shown that the result will eventuate in dollars and cents to the man behind the cow.

Grading cream gives the creamery a chance to build up a reputation (which ought to have a money value) for good butter, because the creamery which buys and pays for grade will receive more good cream than the creamery which pays the same for all cream. An increased over-run is impossible, especially if rich cream is insisted upon, and if the creamery work is done according to the best standard.

The disadvantages lie in the extra work which a cream-grading system will entail upon the cream operator, in carrying out the testing for grade, caring for cream, in a double number of vats, extra work in cleaning, and in bookkeeping. It is necessary to test each delivery of cream separately; and, to be properly done, a report of the condition of his cream should be sent to each patron, together with suggestions for improvement. It is easily seen that in a small creamery, where one man does all the work, the extra work involved, where 60 to 100 separate patrons' cream is dealt with, will be considerable. There is the difficulty in fixing a dividing line between the grades that shall be most generally satisfactory. Bad roads form another complication, as well as the long distances cream has to be hauled. We find it also difficult to convince the patron that the grading is done in an honest and impartial manner. Especially is this so in the case of many patrons of foreign nationality. Grading may be done best where individual cans are used in which to deliver the cream.

These are some of the advantages and disadvantages in grading cream. It remains for us to consider whether it is practicable for the local creamery (say, an average summer plant making 40,000 to 60,000 lb. of butter) to grade the cream delivered to it. The local creamery is in a somewhat different position than a centralised plant as regards cream-grading. This is particularly the case when we consider the sparse rural population in many parts of Manitoba. Cream has to be hauled, in many cases, as far as 20 miles. A creamery of this size may have as many as eight cream routes. The cost of collecting the cream in an average year may be $1\frac{1}{2}$ cents to $1\frac{3}{4}$ cents per lb. In a poor season like the last it may come as high as $2\frac{1}{2}$ cents. In the face of these facts, and in the presence of competition, the local creamery may well hesitate and ask, "Shall we, by grading, receive a larger percentage of good cream than otherwise, and will we be able to turn out a quantity of butter of such improved quality as will compensate for the premium paid for No. 1 cream, and leave such a profit as will sufficiently reward the extra labour expended?" An alternative course presents itself to the creamery having quality in view, and that is, to accept only good

cream, and refuse the bad. Here we are met by the same objections—there is a possibility of losing patrons, and thus increasing the cost of making. Personally, I think that the taking of any but good cream is the poorest kind of business, and that the creamery whose motto is, "Good cream or none," will best succeed. Were it not better to apply the energy used in making up poor cream to seeking a better market for our good butter?

During the past season we at Shellmouth have practised grading. The cream was delivered to the creamery by haulers. The cream was collected twice a week on four routes, and once only on other four. Individual cans are used. The hauler simply brings the cream—the weighing and stamping is done by the butter-maker. We did not seek to impose an impossible standard. We did not insist that the cream should be sweet for No. 1 grade. That would be well nigh impossible. If it was mildly sour, of good flavour, and would run freely through a fine wire strainer of 70 holes to the inch, provided it tested 30 per cent. fat, it was No. 1. That is not a severe standard. Any farmer who has a good separator can produce 30 per cent. cream, and keep it for three to five days in condition to grade No. 1 under the test I have mentioned. This insistence upon 30 per cent. fat for No. 1 grade caused a good deal of criticism, and some dissatisfaction in some quarters. It is hard for the average farmer to realise the importance of skimming a heavier cream—over 30 per cent.—and the benefits accruing to himself thereby. During the past season the proportion of No. 2 grade testing over 30 per cent., was only 3 per cent. We received 36 per cent. No. 1 grade.

If cream-grading is to be used as a method of improving the cream receipts, some kind of grade-card is desirable. Such a card should have the patron's name, date, and pounds of cream delivered, grade also, and the fat test, if the card is to be mailed. The card might have printed upon it, in separate numbered paragraphs, the common faults of cream, and the remedies to be applied. A space can be left for additional card, which would also form a receipt to the patron for his delivery of cream. The sooner the patron knows how many pounds of cream he is credited with, and what his grade and test is, the better will he be satisfied.

These are a few first year's experiences in grading cream. It is, perhaps, too soon to say whether it is an entire success or not. We may lose a few patrons but I think not. If we do, they are knockers, and the creamery is better without them. I believe the result is, on the whole, encouraging. We are up against a great deal of helpless (almost hopeless) ignorance on the part of many patrons. Grading cream is not a panacea for all the ills that the creamery business is heir to. It is, however, an advance step in an effort to make better butter, and more of it. By its use, and by "patient continuance in well-doing," it will have its reward.—"N. W. Farmer."

FEEDING WHILE MILKING.

Most farmers claim that cows will stand quieter and let down their milk more freely if they are given something to eat while they are being milked. But those who have adopted the plan of milking before feeding are seldom, if ever, anxious to go back to the old method of giving the cows something to eat while they are being milked. Few cows seem to be able to divide their attention between the two operations. When the cow has nothing to attract her attention she stands quietly when she sees the milker approach. She also lets down her milk more freely than when she is attempting to eat at the same time. The cow that has her head in the manger seldom sees her milker approaching, and the first intimation she has of his presence is when

she feels the milking-stool against her flanks. If she has a nervous disposition, which is the case with most good dairy cows, she will either jump or kick, and then continue to annoy her milker by switching her tail until he has finished milking.

If the cow is fed at the same time that she is being milked, she is in so great a hurry to get her feed that she becomes restless, and will not give down her milk freely. To make a change from the old practice of milking the cows while they are eating, to feeding them after they have been milked, will probably cause much restlessness on the part of the cows, but as soon as they become accustomed to it, which will not take long, they are much quieter than where both operations are conducted at the same time.

Not only is it pleasanter to milk before the cows are fed, on account of their better behaviour, but from a sanitary standpoint the keeping qualities of the milk are much better when the feeding is done just after milking. Dry feeds contain a large quantity of dust, which is thrown into the air by handling and is generally very heavily laden with bacteria. As the dust settles into the milk pail, it carries with it thousands of these bacteria. In addition to this, the restlessness of the cows, resulting from being milked while eating, dislodges dust from themselves as well as from their milker, which, laden with bacteria, falls into the milk.—“N.Z. Town and Country.”

MILK AND BUTTER COMPETITION, ROCKHAMPTON AGRICULTURAL SHOW, 1908.

The following details, given by a local journal, of the Milk and Butter Competition at the Rockhampton Agricultural Society's Show this year, have been forwarded to us by Mr. H. T. Deighton, dairy inspector:—

A milk and butter competition was held again this year by the Rockhampton Agricultural Society in connection with its annual show. Only five thought it worth while to enter; but they put in nine cows. The prizes on this occasion, as in 1907, were £10 10s., £5 5s., and £2 2s., and the competition, like that of the one preceding it, was carried out on the farms. That is to say, the cows were milked at home, and not, as was the case prior to 1907, on the grounds—in the same bails as they go to every morning and evening, and by the men who ordinarily look after them—a representative of the society attending the day before to see them milked dry, attending the test milkings, weighing the milk obtained at each milking, and taking samples of the milk each time for the purpose of ascertaining the percentages of butter fat. The prizes, of course, as is usual in such contests, went to the three cows that revealed the greatest merit with respect to the weight of milk, the quantity of butter fat, and the ratio of milk to the pound of commercial butter—a point being awarded for every ten days since calving, deducting the first forty days, but with a maximum of 14 points; a point being given for every pound of milk produced at the two milkings; and 20 points being allowed for every pound of marketable butter indicated according to the Babcock milk tester, with a deduction of 10 points each time the proportion of butter fat was below 3 per cent. The conditions also provided that in the case of cows obtaining the same number of points, the advantage should be given to the one that had been longest in milk. The nine cows entered this year were milked last month in the presence of Mr. H. T. Deighton, the Government inspector of dairies for the Rockhampton district, and the tests for butter fat were also conducted by Mr. Deighton. The results of the competition were sealed by Mr. Deighton as soon as they were completed, and were opened yesterday by the president of the Agricultural

Society (Mr. R. S. Archer), and made available to the public. They placed the competing cows in the following order:—

- J. M. Cooper's Rose, 12 years, Ayrshire, calved on the 9th of April, 1908 1
- J. Edmystone's Fanny, 7 years, grade Ayrshire, calved on the 2nd of February, 1908 2
- Goldsbrough, Mort, and Co.'s Lovely of Casuarina, 6 years, Ayrshire, calved on the 23rd of February, 1908 3
- Archer Brothers' Lena, 10 years, Shorthorn-Jersey, calved on the 13th of January, 1908 4
- J. Edmystone's Violet, 8 years, Jersey, calved on the 6th of April, 1908 5
- J. Edmystone's Ruth, 6 years, Ayrshire, calved on the 3rd of September, 1907 6
- S. Hoare's Brindle, 7 years, Ayrshire, calved on the 9th of April, 1908 7
- Archer Brothers' Caroline, 10 years, Shorthorn, calved on the 3rd of March, 1908 8
- Archer Brothers' Whiteback, 11 years, Shorthorn grade, calved on the 15th of April, 1908 9

The milk and cream records of the cows are as follow:—

	Weight of Morning Milk.	Weight of Evening Milk.	Percentage of Butter Fat in Morning.	Percentage of Butter Fat in Evening.	Commercial Butter in Morning.	Commercial Butter in Evening.	Total Commercial Butter.
	Lb.	Lb.			Lb.	Lb.	Lb.
Rose	20½	17	4·2	4·6	0·95	0·87	1·82
Fanny	17½	20	3·6	3·6	0·70	0·80	1·50
Lovely of Casuarina	19½	19	3·4	4·0	0·70	0·84	1·54
Lena	16½	11	5·0	5·2	0·91	0·63	1·55
Violet	20	17	3·4	3·4	0·75	0·63	1·38
Ruth	13½	13	3·6	4·0	0·54	0·57	1·11
Brindle	18	16	3·8	3·2	0·75	0·56	1·31
Caroline	13½	10	5·0	4·8	0·74	0·54	1·28
Whiteback	12½	7½	4·8	4·5	0·66	0·37	1·04

The points gained by each competitor are as follow:—

	Rose.	Fanny.	Lovely of Casuarina.	Lena.	Violet.	Ruth.	Brindle.	Caroline.	White-back.
Commercial butter	36·40	30·00	30·95	31·00	27·60	22·20	26·20	25·70	20·80
Quantity of milk ...	37·25	37·50	38·25	27·50	37·00	26·50	34·00	23·50	20·00
Points added for time in milk	...	5·70	4·00	7·20	...	14·00	...	2·30	...
Total ...	73·65	73·20	73·20	65·70	64·60	62·70	60·20	51·50	40·80

It will be noticed that Fanny and Lovely of Casuarina tied in the matter of points for second position; but, in accordance with the regulation, the second prize was given to Fanny, she having been in milk three weeks longer than Messrs. Goldsbrough, Mort, and Co.'s cow.

In conjunction with the milk and butter competition there was a dairy cows' competition—that is, for cows which give the greatest weight of milk in two milkings—the milkings in the milk and butter competition to be the milkings also in the dairy cows' event. The prizes in this instance were £2 2s. and £1 1s. Only seven cows were entered for this, and the result was as follows:—

- Goldsbrough, Mort, and Co.'s Lovely of Casuarina, with a yield of 38½ lb. of milk in the two milkings 1
- J. M. Cooper's Rose, with 37½ lb. of milk 2
- J. Edmystone's Violet, with 37 lb. of milk 3
- S. Hoare's Brindle, with 34 lb. of milk 4
- Archer Brothers' Lena, with 27½ lb. of milk 5
- Archer Brothers' Caroline, with 23½ lb. of milk 6
- Archer Brothers' Whiteback, with 20 lb. of milk 7

The Horse.

MORE ABOUT THE SUFFOLK PUNCH.

Whether the Suffolk Punch will ever reach the position of the most favoured heavy horse is, perhaps, a matter of considerable doubt, but to those who require for their work a fast, active, good-tempered and good-constituted draught horse, there is no gainsaying the fact that they might do far worse for themselves than by giving a chance to the handsome and long-lived Suffolk Punch, whose antiquity alone may commend him to their consideration.

Even as a heavy saddle horse, the Suffolk is a treasure. The writer bought a beautiful, nuggetty, silver-maned chestnut Suffolk from Mr. White, of Bluff Downs, North Queensland, in 1875. A more powerful, docile horse for a traveller could not be imagined. Fast, he was not; but for endurance he could not be surpassed. The proof of this may be shown that, on one occasion, the writer left the late Mr. William Hann's station at Maryvale (N.Q.) at 6 a.m. to make a station only 40 miles distant. Mr. Hann gave directions for a short cut through the bush; but, as it turned out, "the longest way round would have been the shortest way home," for, after carefully following directions, nightfall found the traveller in a piece of waterless broken country, and during the whole day no water had been found. After a fruitless endeavour to track the footsteps of a shod horse on the bank of a dry gully, it was decided to leave the matter to the horse. He set off at a quick walk, which he never relaxed till 4 a.m. the next morning, when he brought up at the first water on Tara station, and then trotted gaily on to Maryvale, a journey of nearly 80 miles. At 8 a.m. he started again, this time in company with the mailman, and reached his destination at 6 p.m., making a journey of 120 miles with only a spell of about two hours, and he was as fresh as a daisy on arrival. Next day he was ridden 30 miles a day to the Etheridge, *via* Gilberton, and returned to Townsville, after three days' spell at Georgetown, as lively and in as good condition and temper as if he had only had a day's outing. That horse cost £25, and he was worth £50. Now, here is an account of this breed of horses which must convince anyone that the Suffolk Punch is the horse, *par excellence*, for the farmer, taken from a paper by Mr. A. Jaques,* of Lamerton, Alberta, Manitoba:—

Perhaps, in the eyes of the ordinary visitor to an agricultural show, there is no variety of the so-called heavy horse more attractive than the Suffolk. The breed, moreover, comes as somewhat of a novelty to many persons, for, in spite of the great claims possessed by the Suffolk upon the suffrages of the agriculturist and the townsman, it is still in East Anglia that his merits are most keenly appreciated, and, in fact, the farmers in that part of the country prefer the Suffolk to any other breed of heavy horse.

It is still, however, against the breed that the proportions of a Suffolk do not equal those of a Clydesdale or a Shire horse, many persons being thereby led away into a belief that the east country animals are proportionately weaker than the others; whereas those who are best acquainted with their merits entertain the opinion that, considering his height—16 hands 1 inch is the recognised limit of stature in connection with this breed—the Suffolk is quite as powerful an animal as any other breed of horse in existence.

* Mr. Jaques is a breeder and importer of these horses, and has in the past two years imported direct from England 17 Suffolk Punch horses and 30 Suffolk sheep.

Probably, therefore, if he were better known in Western Canada, the Suffolk would considerably increase the circle of his supporters; but, in the face of the patronage that is now being extended to both Clydesdales and Shires, the development of the Punch will be for a time retarded. Nevertheless, he is holding his ground in many other countries, and is being largely sought after by the Germans, Austrians, and Russians, to be used in their Government studs for the purpose of crossing and getting artillery horses. No doubt this horse has not the weight or power to draw through crowded streets heavy lorries and other such cumbersome vehicles when loaded to their utmost. Such duties lie far more within the province of the Clydesdale or the Shire; but, in front of a plough, with a good man behind it, a pair of Suffolks can get through a day's work that should amply satisfy the requirements of any reasonably-minded agriculturist. Then, too, for the lighter class of goods traffic in towns, the Suffolk is a very suitable horse; he is so much more active than the Clyde or Shire, in addition to being faster than either, that he can get through a day's work in a comparatively light wagon far better than they.

The precise origin of the Suffolk is, like that of most ancient breeds, enshrouded in obscurity; but, at the same time, the antiquity of this horse is absolutely beyond all question. So far back as the year 1720 allusions to the breed in the Ipswich Journal are so frequent as to render it certain that it was firmly established at that remote period. Indeed, it is asserted by some that the Suffolks were cultivated as a distinct breed 500 years ago, by crossing the old Norman horse with East Anglian mares; though, it must be observed, in justice to other breeds of less remote antiquity, that the proofs of such assertions are insufficient. Be this as it may, the fact remains that the Suffolks of the present days can boast of pedigrees that extend back as far as 1768, at which period there existed a notable but nameless stallion belonging to one Crisp, a resident of Ufford, near Woodbridge.

Of course, no colour of coat other than chestnut is admissible in an animal that is desired to enter for the Suffolk Stud Book Association, it being distinctly laid down that, though the shade may vary, there is no place for any horse save chestnuts in the Society's official volume.

In addition to colour, the Suffolk is distinguished from the Clydesdale and the Shire horse by the fact that he is a clean-legged animal, and does not possess the extreme amount of feather that is so much sought after by breeders of these varieties. This circumstance may very possibly be accepted as an additional reason for the slowness which has characterised the headway made by the Suffolk in Canada, for it seems that the majority of agriculturists in this country are great advocates of hair and bone, and a general belief prevails that if hair is absent on a heavy horse's legs, bone is certain to be deficient likewise. This, however, is not generally accepted by the breeders of Suffolks, who support their contentions by measurements, and assert that their favourite horse—that is, when his height at shoulder and general bulk are taken into consideration—is fully the equal of his heavier rivals as regards the amount of bone he possesses below the knee. As a case in point, Mr. Hume Webster refers to Mr. Alfred J. Smith's champion stallion Wedgwood, who, at the time he wrote, was five years old, and measured 7 feet 10 inches in girth and 10 $\frac{3}{4}$ inches below the knee—a very considerable measurement, when it is remembered that there is no hair included in the dimension given. Wedgwood, it may be stated, was foaled in the year 1886, and was the winner of championship at the show of the Royal Agricultural Society of England.

The Suffolk, moreover, is credited with a very enviable reputation for being a good horse so far as the soundness of his feet is concerned, and consequently it is claimed for him that he lasts longer upon the stones of a

town than any other variety that is put to the same class of work. Longevity, indeed, is one of the chief claims that Suffolk breeders insist upon making for their horses. As an instance, it is stated in the Society's stud book that at one of the exhibitions held by the Suffolk Agricultural Society, a brood mare, aged 37 years, was amongst the competitors, and at that time she was accompanied by a sucking foal. Julian's Boxer travelled as a stallion for twenty-five seasons. The dam of Lofft's Cupbearer, owned by the Rev. O. Reynolds, of Leabeach, was one of the sixteen foals which her owner had bred from her dam in sixteen years, and the mare from which Rising Star, the first prize horse at Leeds in 1861, was bred, was 22 years old when the colt was foaled. These are a few instances of the longevity and vitality of the Suffolk horse, and these could be multiplied many times were it necessary to do so, but enough has probably been written to convince the reader, if he were unacquainted with the fact before, that the breed now under consideration is a very remarkably long-lived and fruitful one.

The extreme docility of the breed is another great point in its favour, as it is something for an owner to feel that he possesses a strain of horses that rarely, if ever, develop vice; but, on the contrary, are usually endowed with the sweetest of tempers and generosity. That the Suffolk is a very willing horse is rendered quite apparent by a visit to any farm upon which he is employed. Unlike many chestnuts, too, the natural gameness of the Punches is not neutralised by hot-headedness or vice of any kind.

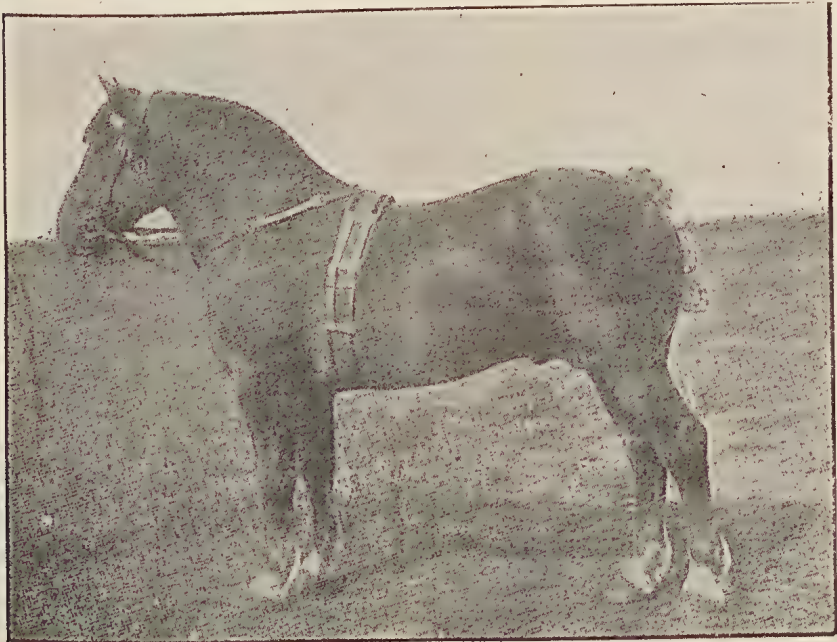

On the contrary, they are a somewhat phlegmatic dispositioned variety, though they possess an amount of courage which enables them to face and endure the hardest of work. Above all things, he is an agricultural horse; but, where pace and strength combined are required, as in the case of town work, he is equally at home. Beyond all question of doubt, he is the most nimble and active of all the so-called heavy varieties, whilst the Suffolk, for his size, is an extremely small feeder, and will flourish and look well upon an amount of food that would be totally insufficient for many other big horses.

The head of the Suffolk Punch shows more breeding and quality about it than that of any other heavy horse, a very conspicuous feature being the eye, which is full of expression, yet mild and intelligent-looking. The neck is powerful and well formed, and the crest beautifully turned. The head-piece is well carried; the shoulders, which are very long, lie rather forward, this being desirable for the purpose of draught. The chest is wide and deep, the girth of the middle-piece being very considerable, while the body, as a whole, is long and substantially built. The back is very strong, the hind-quarters long and heavy, and close coupled with the loin, the legs standing well under the body. The fore-legs—a very essential point, for however good an animal's top may be, he will be worthless if he has no legs and feet to carry him—must be short and flat, possessed of plenty of hard bone, big and free from feather, whilst the pasterns are short and powerful with little hair on them, the feet being of a good size and truly shaped. In general appearance, the Suffolk Punch is very happily ascribed as being long, low, and wide, and this summary of his outline cannot possibly be bettered:—

“The Suffolk is an excellent mover, with a smart, quick step, a true balance all round at the trot, and a magnificent walker.” As may be naturally supposed, an ultra-high flashy action is not desired, and it is naively added that “a horse weighing a ton, bending his knee up to his throat-latch, and striking the granite with his feet like a sledge-hammer, is not an exhibition that the Suffolk trader delights in.” In fact, a Suffolk that is heavy enough for the largest dray is seldom, if ever, called upon for an exhibition of speed and high action. Even if he is only up to ordinary van work, he is never likely to be wanted to go more than seven or eight miles an hour, and this class of animal will never scale a ton.

The Suffolk Punch is now being introduced for farm purposes by the Department of Agriculture and Stock, the first lot having been obtained from Mount Abundance, and we shall not be surprised to learn that before long the farming community will have appreciated the splendid qualities of the breed as active, enduring, docile animals, for the plough and the country wagon.

TO CURE A JIBBING HORSE.

The “Nor'-west Farmer” gives the following as a certain method of overcoming the jibbing habit of a horse:—“Whipping such a horse is generally of no use. Different horsemen have different ways of treating balky horses. One of the most successful ways of making a balky horse work is to hitch him to a tried and trusty animal that will pull up steadily but surely. Take a small stout cord—a small rope is good—and fix it with a noose around the tail of the balky horse after the fashion of a crupper. Pass the free end of the rope over the horse's back and tie it to the large hame rings of the other horse. Have the rope adjusted right as to length, and then start the old horse up quietly. Mr. Balky horse will perhaps lean back in his collar and not budge an inch, as was his usual custom. This will not continue long, however, for he will soon feel that noose tightening on his tail, and the more he pulls back the tighter the noose draws and the harder the rope pulls at his tail-head. It will take just about ten seconds, if the rope and noose are fixed properly, to convince any balky horse that he has become addicted to a bad habit of which he should speedily rid himself. He will give a jump, and may land 3 or 4 feet ahead of the other horse, and perchance lean back in his collar again, but just as soon as that noose begins to draw on his tail Mr. Horse will begin to move, and after two or three times backing up on the noose he will walk right off, and, with most horses, the balking habit will be completely overcome. This treatment will not injure the animal, but it will teach him a valuable lesson which is hard to learn in any other way.”

[We have seen a confirmed jibber induced to move along by simply passing a rope round his knee and pulling gently on it when the leg is lifted.—Ed. “Q.A.J.”]

Poultry.

DESICCATED EGGS.

From a report lately made by Mr. J. B. Larke, Trade Commissioner for New Zealand, it appears that a new process has been devised in Melbourne for desiccating eggs. He describes the process as follows:—

“Desiccated eggs are not substitutes for eggs, but newly-laid eggs treated by a process by which only the shell and water contents of the egg are removed, and the whole substance of the egg, yolk, and albumen converted into powder. The eggs first pass through a dark room, being carried on a perforated rolling table over a 50-candle-power-light. Any eggs not perfectly fresh, or dirty in any way, are at once detected and put on one side. The sound eggs are carried along and go into a centrifugal separator, revolving at a tremendous rate. Here the eggs are smashed, and the shells separated from the liquid matter which flows into a small tank, and is then pumped up to another tank, where a preservative is added. Below this tank, in a very hot room, with a temperature of 120 to 130 degrees, there are great cylinders, or drums, slowly revolving at the rate of one to two and one-half minutes. The liquid egg substance goes from the tank into troughs below these cylinders, and, as they revolve, become attached to them. By the time a cylinder has completed its revolution the coating has dried, and a further coating adheres. Ultimately this coating comes off in flaky pieces, which are ground into a powder.

“This powder will, it is claimed to have been proven, keep for years, and only requires the addition of milk or water, when the powdered eggs will reconstitute, and be ready for use for any purpose the same as a newly-laid egg. The powder is rich and attractive-looking and is reported by the Government Analysts of New South Wales and Victoria to contain no chemical preservative. No part of the egg, except the water, has been removed.

“There is no question that if this process were perfect, as the newspapers state, it would be of great value. It must, however, be added that the process is not yet perfected. The inventor has some difficulties still to overcome before it can be a commercial success, one of which is the reduction of the dried egg to powder. It is hoped that this and other obstacles to success will shortly be overcome.”

ARTIFICIAL INCUBATION BY ELECTRICITY.

Incubation by electricity is the latest innovation in the poultry world. After three years of experimenting, Otto Schultz, an electrician of Strassburg, claims to have perfected a device whereby eggs are hatched with the artificial aid of the fluid which is working such wonders in other fields. In the electric incubator the automatic attachment keeps the temperature within one-tenth of a degree of the normal temperature of incubation. The degree of moisture in the air is also kept automatically. It is claimed for the electrical device that under ordinary conditions 90 chicks can be counted on out of 100 eggs. The amount of electricity consumed is very small. The brooder for raising the chickens after they are hatched is also heated by electricity. The upper part of the brooder is arranged for newly-hatched chicks, and is heated by electricity. The lower part is also warmed by the same means, and built so the chicks can run outside to eat and at the same time find protection and warmth within. This new wonder (says the “Rural Californian”) will doubtless soon be on exhibition at the poultry shows and fairs, and it is needless to guess that great curiosity will be felt by all progressive breeders to examine and test its merits.

Botany.

ON THE SO-CALLED "AFRICAN" WONDER GRASS."

By F. MANSON BAILEY, F.L.S., Colonial Botanist.

There having been considerable controversy relative to the nomenclature of the so-called "Wonder Grass," *Panicum muticum*, Forsk., I have been requested by the Under Secretary to say a few words on the subject, as this species is being grown and distributed under the name of *P. spectabile*, Nees., because it is said that the late Baron Mueller sent to Queensland seed of a grass labelled *P. spectabile*, Nees. This is no proof of the correctness of the name, for no doubt the Baron received the seed under the latter name, and, thinking that it would be a suitable grass for this State, sent it here without testing it to find out the correctness or otherwise of the name. I might mention that I often receive seeds in this way from other countries, and—especially in the case of grasses—cannot always vouch for the correctness of the names.

In the hope of making the matter clearer to those interested, three illustrations are here given, Plate I. and Plate II. being reproductions from Trinius' species Graminum, and Plate III., representing a specimen grown by the late Dr. Joseph Bancroft, and is identical with those received from Mr. R. Simmons. The following letter was recently sent to the Department by Mr. Simmons:—"Dear Sir,— . . . This grass was sent to the gardens about twenty-four years ago, by the late Baron Ferd. von Mueller, as *Panicum spectabile*, and has been known here as such ever since. Recently I sent a specimen of it to Mr. F. M. Bailey, and he says it is *Panicum muticum*. I may say in connection with it that a good many people are under the impression that it is capable of resisting drought, but that is a mistake, as it prefers, and indeed will only flourish in, localities where it has abundant moisture.—I have, &c., R. Simmons." The grass on Plate II. is figured by Trinius under the name of *P. barbinode*, Trin., but Sir Joseph Hooker, in his "Flora of British India," and also in the "Flora of Ceylon" (where he states that "*P. muticum* is growing wild and cultivated in swampy places"), includes *P. barbinode*, Trin., and others—as many as fourteen—as synonyms of *P. muticum*, Forsk. In the plates will be seen the distinction, but the difference in growth may be given, as in *P. spectabile* it is erect, and in *P. muticum* ascending or procumbent.

THE PROPHET'S MARES.

Mohammed, according to tradition, set great store by the readiness of horses to obey any signal to which they had been made accustomed, and he selected mares for breeding purposes by a test of their obedience. He shut up a drove of mares within sight of water, and kept them without drink till they were almost famished with thirst. Then the drove was released, and, naturally, started at a headlong gallop for the water. When they were in full flight a trumpet sounded the "halt." Only five, some say three, mares obeyed the call and stopped, the rest being intent on assuaging their thirst. The three obedient mares were chosen as dams, and were honoured by the title of "The Prophet's Mares."

Plate II.

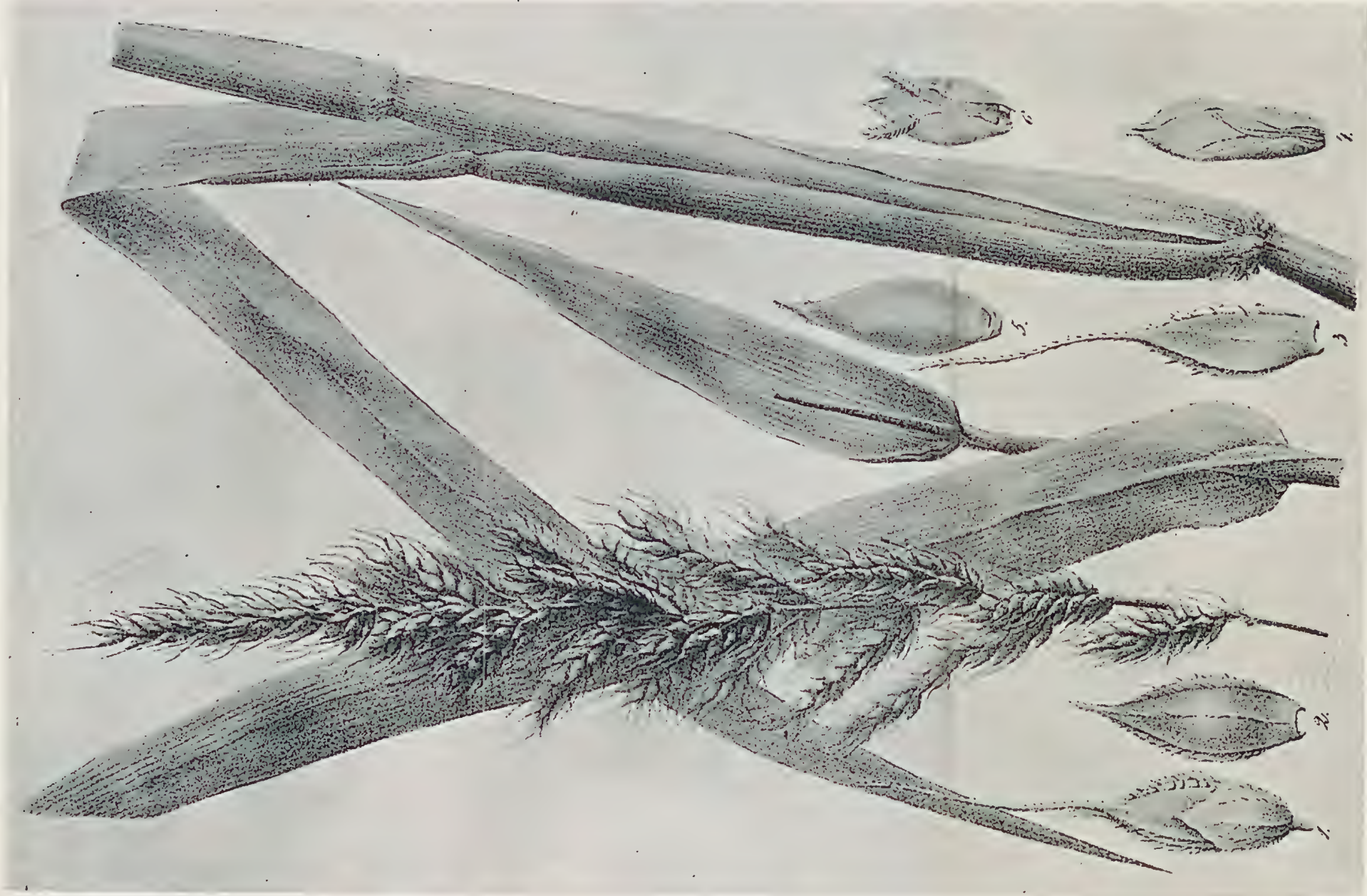

Panicum spectabile, Nees.

1. 2. 3. 4. 5. 6. 7. 8. 9. 10. 11. 12. 13. 14. 15. 16. 17. 18. 19. 20. 21. 22. 23. 24. 25. 26. 27. 28. 29. 30. 31. 32. 33. 34. 35. 36. 37. 38. 39. 40. 41. 42. 43. 44. 45. 46. 47. 48. 49. 50. 51. 52. 53. 54. 55. 56. 57. 58. 59. 60. 61. 62. 63. 64. 65. 66. 67. 68. 69. 70. 71. 72. 73. 74. 75. 76. 77. 78. 79. 80. 81. 82. 83. 84. 85. 86. 87. 88. 89. 90. 91. 92. 93. 94. 95. 96. 97. 98. 99. 100.

1. 2. 3. 4. 5. 6. 7. 8. 9. 10. 11. 12. 13. 14. 15. 16. 17. 18. 19. 20. 21. 22. 23. 24. 25. 26. 27. 28. 29. 30. 31. 32. 33. 34. 35. 36. 37. 38. 39. 40. 41. 42. 43. 44. 45. 46. 47. 48. 49. 50. 51. 52. 53. 54. 55. 56. 57. 58. 59. 60. 61. 62. 63. 64. 65. 66. 67. 68. 69. 70. 71. 72. 73. 74. 75. 76. 77. 78. 79. 80. 81. 82. 83. 84. 85. 86. 87. 88. 89. 90. 91. 92. 93. 94. 95. 96. 97. 98. 99. 100.



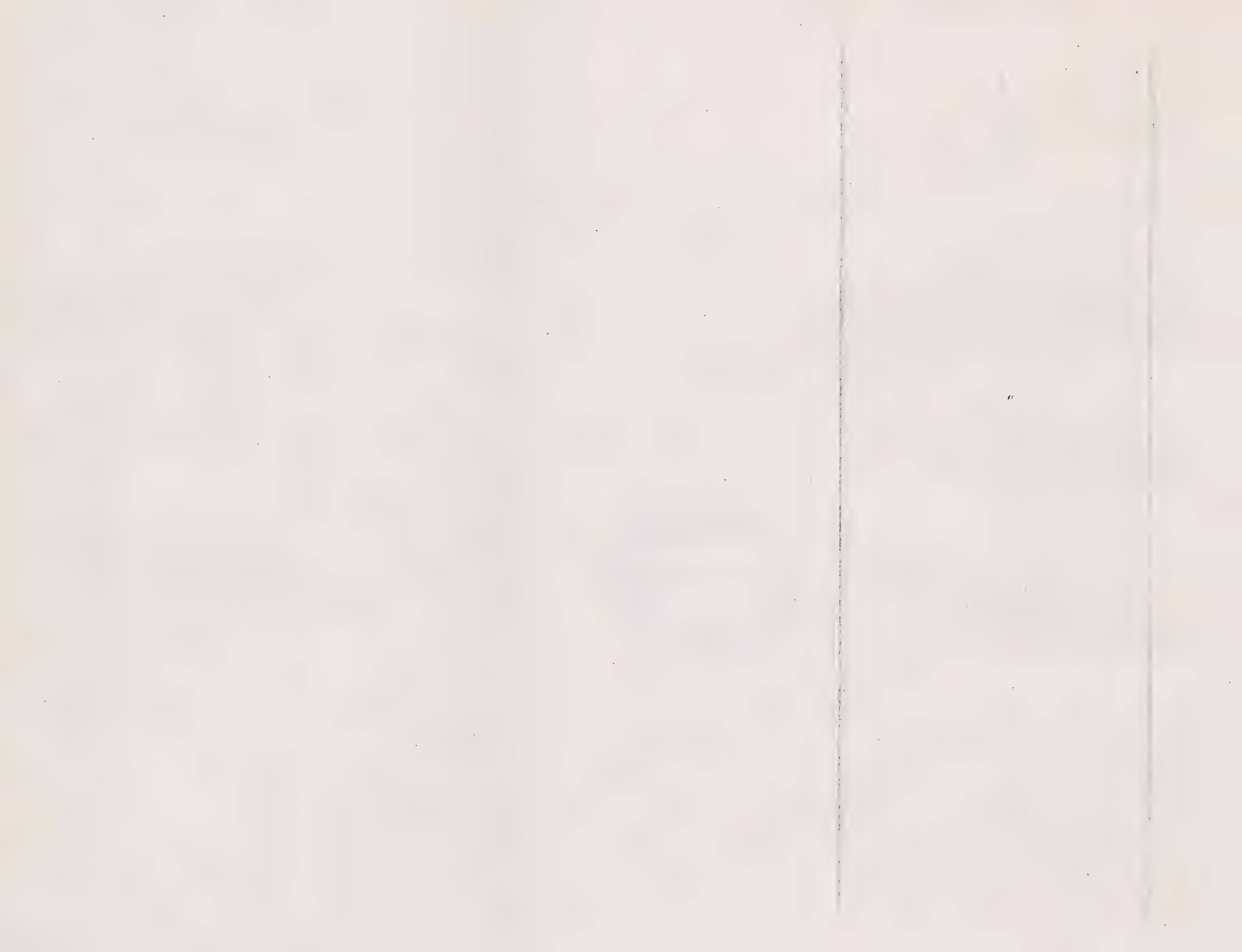

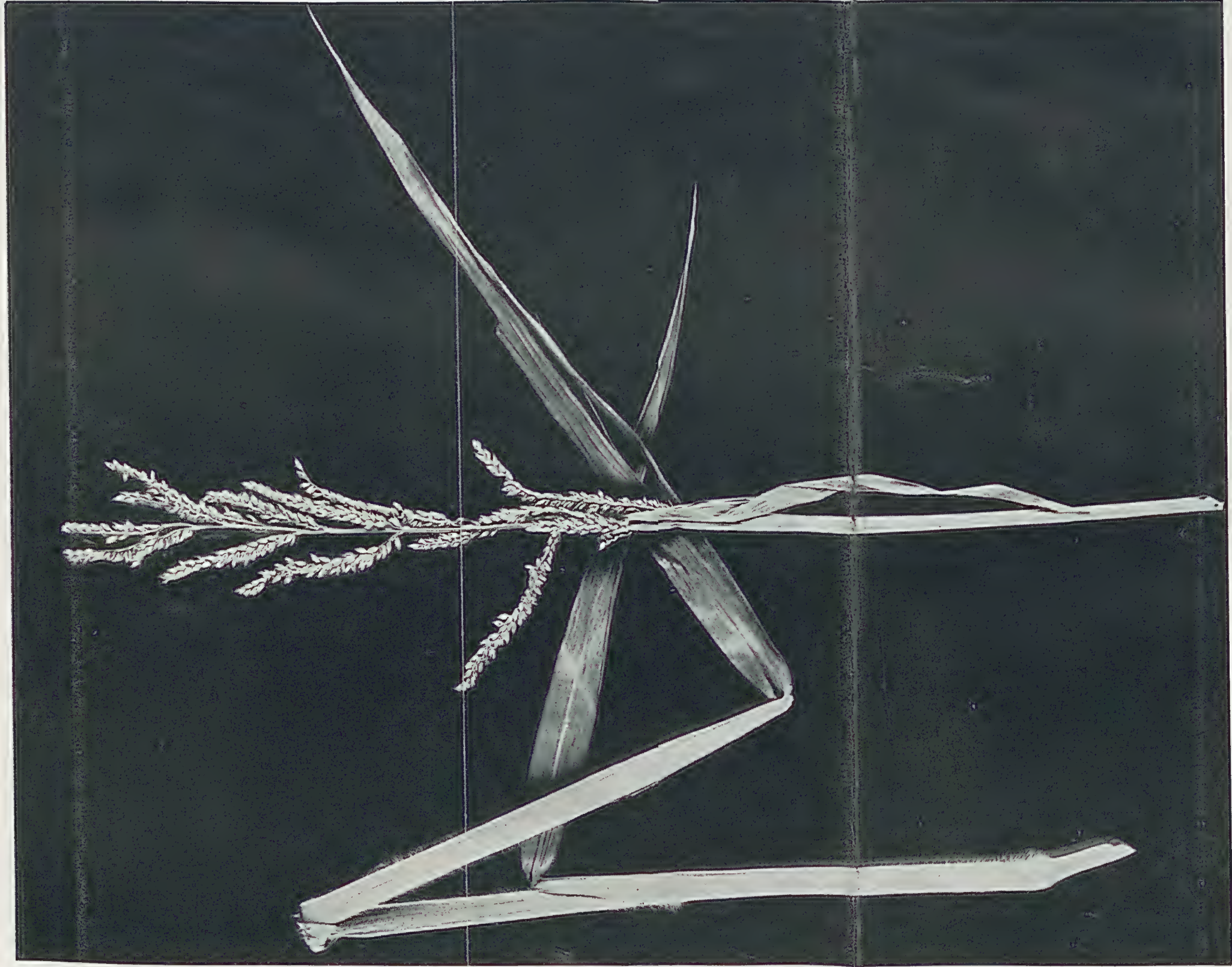

Panicum muticum, Forsk.

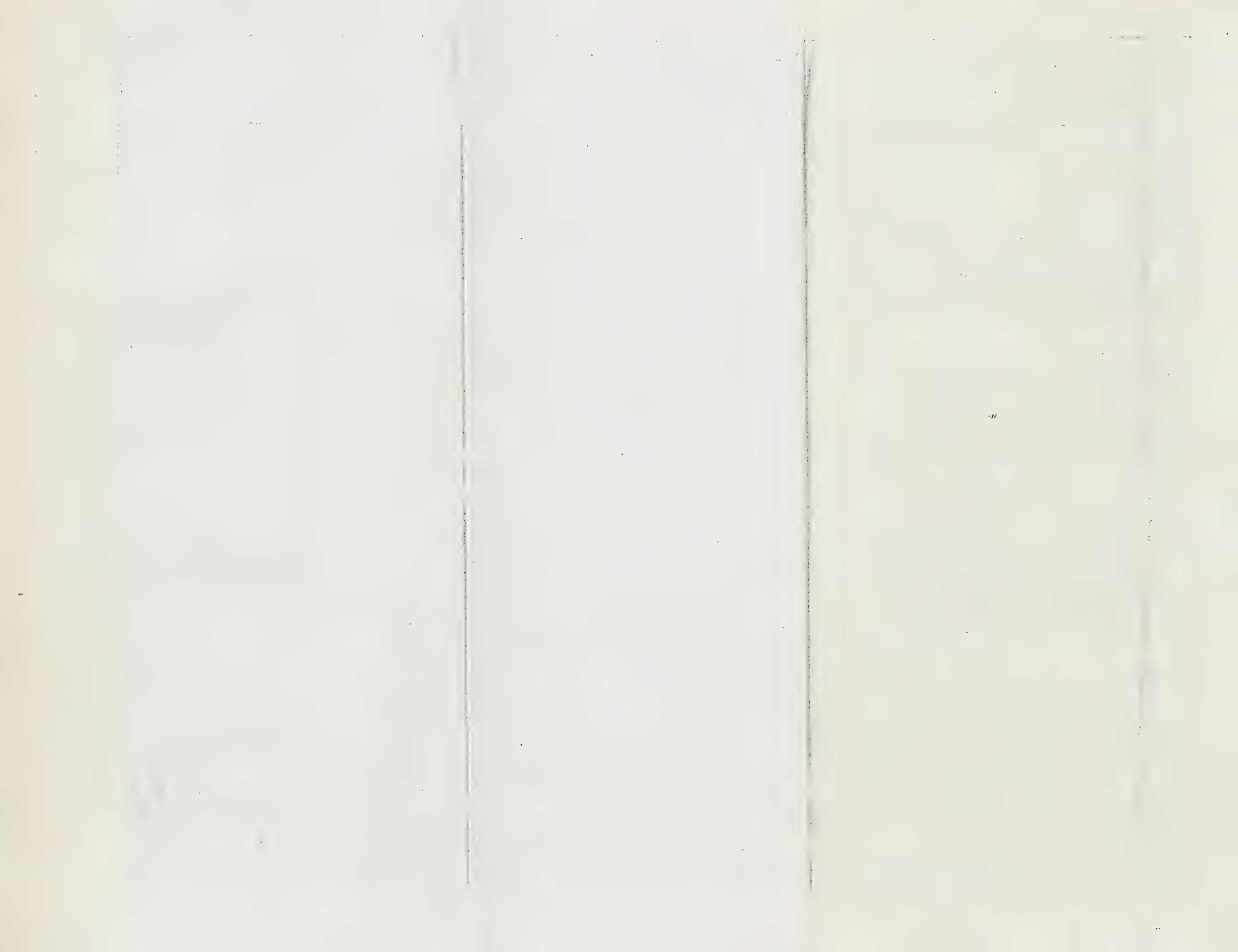

The Orchard.

QUEENSLAND BANANAS.

In connection with the banana trade of Queensland with the Southern States, "The Fruit World" (20th May) says:—

Undoubtedly the banana, of all fruits, is easily first from a large consuming public point of view. Apples and pears are too costly at 3d. and 4d. to 6d. per lb. retail, and our masses must perforce buy their fruit cheaper than this or do without it. Bananas, at 4d. to 6d. per dozen, gives them a regular supply for home use. This is so in most parts of the world.

Then it is a fruit of valuable food properties, being composed of 22 per cent. of starchy substance.

Atwater, chemist of the Agricultural Department of the United States, in making a comparison of the value of the apple, orange, and banana, showed their composition to be as follows:—

| | Water. | Proteid. | Fat. | Carbo-hydrate. | Ash. |
|------------|--------|----------|------|----------------|------|
| Apple ... | 84.6 | 0.4 | 0.5 | 14.2 | 0.3 |
| Orange ... | 86.9 | 0.8 | 0.2 | 11.6 | 0.5 |
| Banana ... | 75.3 | 1.3 | 0.6 | 22.0 | 0.8 |

Speaking on the nutritive value of the fruit, Sir James Crichton-Browne, an eminent English physician, lately said, "I wish all school children could have bananas from time to time, as they are food fruit, containing in an agreeable form all the essential elements of nutrition. The banana, when of the proper degree of ripeness is, in the guise of a cheap luxury, a substantial addition to our food supply, likely to commend itself more and more to the working classes in our large towns."

The importations from Queensland during the last five years are as follow:—

| Period. | Bunches. | Cases. |
|--|----------|--------|
| 1st July, 1902, to 30th June, 1903 ... | 767,481 | 3,234 |
| 1st July, 1903, to 30th June, 1904 ... | 653,639 | 667 |
| 1st July, 1904, to 30th June, 1905 ... | 658,981 | 3,899 |
| 1st July, 1905, to 30th June, 1906 ... | 403,775 | 1,630 |
| 1st July, 1906, to 30th June, 1907 ... | 443,760 | 17,726 |

The statistics appear to indicate that the consumption fell away from 767,481 bunches and 3,234 cases in 1902-3, to 403,775 bunches and 163 cases in 1905-6. But this is mainly accounted for by devastation in the fields by cyclonic visitation.

MATURE FRUIT.—It would be considerably better if the fruit could be forwarded in not such an immature stage as is generally the case. The sugars of the fruit are prevented from developing, and most of the fruits are not so good for food purposes, in fact some bananas recently seen in Adelaide would be more likely to tax the digestive apparatus than help it.

The reason of this is, of course, the fear of fruit fly; and the receiving of green fruit only is an undoubted preventive measure for importing States; but surely the other extreme of sending unfilled fruit is against all sense. Could not the banana be picked green, and therefore fly safe, and be timed to reach this market to ripen up lusciously and full of its fine flavour and food qualities?

WHAT QUEENSLAND SAYS.

In this connection, Mr. A. H. Benson writes to us as follows:—

Re the unripe condition in which you get our bananas—that is not our fault, as should the fruit arrive coloured, it is either condemned for fruit fly

or else it is said to be too ripe for your trade, and dealers will not take it. In other words, your people demand a half-grown fruit, and you get it. If you can educate them to know better, we will be glad to send you better filled fruit, provided that we can get the steamship combine to give us better ventilated holds, so that the fruit will carry better. To land fruit as you want it at present our growers have to cut it about half-filled.

Our Northern growers are obliged to cut the fruit so immature, in fact, that the fruit will keep its green colour during the journey from the North to Melbourne, and still arrive in a green condition, and take days or weeks to ripen. The question of netting the fruit prior to shipment will not result in the growers allowing it to become better filled under present conditions, as if allowed to become better filled or more mature on the plant, it will ripen up quicker in transit, and you will get fine good luscious ripe fruit on its arrival, instead of the green which your market demands.

The present method of transporting bananas is, in my opinion, all wrong, and this Department is in communication with the steamship companies on this matter, as, in order to give you better fruit, we must have such accommodation for it on the boats that there is some chances of its reaching its destination in good order; at present only very green fruit will carry.

Fruit cut seven days in the tropics would not carry to Brisbane let alone Melbourne. The bunches are covered with the netting, thus ensuring immunity from the attack of the fruit fly, and, as soon as they are sufficiently developed, with the saving clause of immaturity which your people like, they are cut and shipped right away.

Were it possible for the fruit to be carried under more favourable conditions, and I see no reason why it should not, then it would be possible to allow the fruit to become properly matured here, so that you would get a full fruit with its full flavour instead of the immature article you usually get.

THE HARDY ROSELLA.

We have received from Mr. E. J. Phayre, Wooloowin, a very fine sample of rosellas, which, he says, are an average sample of the first picking from his plants on 27th May. The plants were grown on gravelly soil, and no manure was applied to them. Any moderately good soil will grow rosellas well. Land with a clay subsoil, if the latter be near the surface, is, however, to be avoided. A well-drained, gravelly soil suits the requirements of the plants, as is evidenced by the fine fruit grown by Mr. Phayre.

CATTLE TICKS AND THE MONGOOSE.

The history of the cattle tick in Jamaica is bound up with that of the mongoose. In 1872 nine mongooses were imported by Mr. Espent, in the hope that they would thrive and exterminate the "cane rat," which was making impossible the cultivation of sugar. The mongoose thrived and multiplied, and, by destroying the rats, restored the sugar-cane industry, and also made the cultivation of cocoa possible. But, when the cane rats had become few, and the mongooses many, the latter turned their attention to ground-nesting birds, and decimated these; also, they drove the surviving rats to change their habits, and make their nests in trees. Between mongoose and tree-climbing rat the birds suffered terribly, and the disappearance of insectivorous birds was soon followed by the spread of the ticks, which theretofore the birds had kept under, until the ticks became so prevalent as to be a perfect scourge.

Horticulture

FLOWER GARDENING.—No. 6.

By THE EDITOR.

PLANTS SUITABLE FOR OUTDOOR CULTURE.

FUCHSIAS.

Many of these graceful plants are amongst the most beautiful of hardy or half-hardy plants for outside borders, while others of a more tender constitution are more adapted for inside culture. Whether plants be required of a large size for exhibition, or others of smaller proportions for greenhouse or window decoration, centres of vases, and outside flower borders, the fuchsia is equally well adapted for one and all.

Propagation is effected by seeds for the raising of new varieties, and by cuttings for the perpetuation of those already obtained, or for any of the species. Seeds ripen freely in summer on the majority of plants, if they are required. When ripe, they should be washed from the pulp surrounding them, and afterwards dried, being then either sown at once or kept till the following spring.

CULTIVATION.

Cuttings of fuchsias obtained from the points of young, growing shoots that are free from flowers root readily at any season. The best are those produced from old plants when started in early spring, and these may be grown very rapidly the following summer. The general treatment in the early stages is similar at any season. The cuttings should be placed in light soil, about six in a 3-inch pot, and plunged in a warm propagating frame. When rooted, they should be potted singly, and kept in a light position to induce a short-jointed sturdy growth. A temperature of about 60 degrees, with a rise by sun heat, is one most suitable for the young plants in spring, and plenty of water should be applied, with a syringing in the morning and afternoon. Apart from inducing growth, this tends to keep down insects. Many of the best-habited varieties will require but little stopping or training beyond placing a stick to the leading growth and looping the others to it. Before the roots become much restricted for room, the plants should be placed in 5-inch or 6-inch pots, in which any of the plants will flower if so desired, or they may then be transferred of almost any ordinary size. Fuchsias will succeed, if proper attention be bestowed, in almost any soil; but, where there is a choice, 2 parts loam to 1 of cow dung, or any other good manure, should be selected, well mixed, and used in a lumpy state. Plenty of air and a slight shade are necessary for plants grown under glass in summer, particularly when flowering. Liquid manure may be used with advantage so soon as the pots are filled with roots. Stock plants, or any required for growing another year, may be ripened outside; and, in frosty districts, such as the Darling Downs and parts of the Southern Queensland border, stored in any cool dry place. These should not be repotted until new growth has commenced. Tender varieties, grown in the open air, should be at least one year old when planted out, and they may be lifted and treated in a similar way.

NEW RACE OF FUCHSIAS.

During the past few years there has been a revival in the interest taken in this useful class of plants in England, but in the ordinary varieties no very great improvement has been made, yet some very distinct hybrids from triphylla, corymbiflora, and fulgens, of which it would be difficult to give the

exact parentage, have been produced. They are chiefly of Continental origin, and some of them are remarkably pretty, and the terminal corymbs continue to elongate, and keep up a succession of bloom for a long period. A contributor to the "Garden," Mr. H. J. Jones, of Lewisham, has introduced a most interesting collection, and having seen them from time to time all through the season, I can say that they are certainly worthy of attention. They are readily propagated from cuttings in the spring, and give little trouble. Potting in good loam containing some manure and sand, careful watering, and giving liquid manure when the pots are full of roots will ensure success. They may require a little shade during very bright weather, but the more light they can have the better. It is only when the air is very clear and the sun comes out that they are likely to suffer. They may be potted on into fairly large pots, and will not require so much attention. When growing freely they take up large quantities of water, and it is when they are allowed to get a little too dry that they are most liable to suffer from the effects of the sun. I have noted the following as being amongst the best (it would be better if some of the names were Anglicised):—Gartenmeister Bonstedt, the flowers are clear orange-scarlet, with long tube and short lobes, and are produced in drooping terminal racemes, the leaves broad, with dark veins; Gottingen, is of similar habit, with flowers of a deeper shade of colour; Coralle, apricot with a coral-red shade; Traudchen Bonstedt, pale salmon-pink with light tips to sepals, very distinct pale-green foliage; Andenken An H. Henkel, red, with a rosy-pink shade, dark foliage; Thalia, clear-orange, rather large broad leaves with dark veins and stems; Furst Otto von Wernigerode, rosy-pink flowers, produced in loose racemes, very distinct in habit; Mary, rich crimson flowers in drooping terminal racemes, long narrow leaves, but in this I find the strong secondary shoots shorter, broad leaves; and Eros, dwarf-growing, with pale-green leaves and terminal clusters of short-tubed flowers, which stand erect, and are of a pale-salmon with yellow shade.

SOME GOOD VARIETIES.

Single.

Beauty of Exeter.—A mixture of white and crimson, very floriferous.

General Roberts.—Of beautiful habit; flowers 4 inches long, sepals rose, deepening into the corolla to shaded crimson.

Fuchsia procumbens.—As a basket plant or for window-box culture the graceful trailing Fuchsia procumbens is one of the most desirable. The interesting little flowers are followed by large bright-red fruit. The plant, when not in bloom, has a close resemblance to Muhlenbeckia complexa. Grown with Asparagus sprengeri it is very effective.

Rose of Castile.—White sepals, corolla, violet.

Mrs. Rundle.—Flowers $2\frac{1}{2}$ inches long, with spreading sepals, $4\frac{1}{2}$ inches across; sepals, flesh colour, corolla, orange-scarlet.

Double.

Avalanche.—Tube and sepals crimson, corolla, purple.

Countess of Hopetoun.—Very large corolla, pure white, dark red sepals.

Jumna.—Short tube, and very broad, bright crimson sepals; very large rich, purple, double corolla; base marked with rosy crimson.

Other good double fuchsias are—Mrs. Marshall, Jubilee, La France, Frau Emma Topfer, Molesworth, Mrs. E. G. Hill.

COCKSCOMB (*Celosia*).

There are a great number of varieties of this species, all of which are very ornamental. They grow to perfection in the open air almost everywhere in Queensland. A good specimen of *C. cristata* should not be more than 9 inches high, and quite as wide over the top of the flower head, which

should be as thick as possible, and of a dense colour. For this great heat is needed, hence they are at their best here during the months of February and March. The best soil to grow celosias is in a half-rich sandy loam, with half-rotten cow and stable manure mixed with a good dash of silver sand. Seed should be sown about August and September, in pans or in well-drained sandy soil. Care must be taken that the soil does not get dry. When the plants are large enough to handle they may be planted out. Grow them as quickly as possible, and keep them rather dry to induce flowering.

VARIETIES.

C. argentia, *C. cernua*, *C. cristata*, *C. cristata variegata*, *C. c. comosa*, *C. Huttonii*, *C. pyramidalis*, *C. c. coccinea*.

PEONY.

There are two distinct sections of peonies in general cultivation, both of which are exceedingly ornamental and useful for out-door decoration. The Moutan, or tree peony, is a sub-shrubby plant, of which there are many varieties. The other section is that of the herbaceous peony, the representatives of which annually form flower stems that also die down each year. Peonies of any sort prefer a rich, deep soil, which should be well trenched before planting and have some rotten manure incorporated. A top-dressing of the latter should also be given, and manure water in summer is beneficial when growth is being made. Herbaceous varieties succeed in almost any position, and, when in flower, are very effective and showy subjects. On this account they are, in European gardens, usually planted in the front part of shrubberies, and of wide, mixed borders. They may also be planted in beds by themselves, in positions where an effect from a distance is desired.

Tree, or Moutan peonies, very frequently suffer from the effects of spring frosts. These varieties should succeed well in Queensland, yet we never see them in our gardens, although seeds and roots have from time to time been imported, usually arriving in a decayed condition.

A mulching of manure over the surface of the soil in summer is a great help, by affording nutriment, and also preventing evaporation.

Tree peonies may also be grown in pots, and they may be gradually forced to flower in July, but this renders them useless for a similar purpose for a year or two afterwards. To maintain an annual exhibition indoors, three sets of plants should therefore be provided, one being introduced every third year.

PROPAGATION.

Propagation of herbaceous peonies is effected by division, but this should not be practised more than is necessary, because of its weakening influence on the parent plant. Large clumps soon form when they are well manured and left alone; they should not be planted too deeply.

VARIETIES WHICH MIGHT BE SUCCESSFULLY GROWN IN QUEENSLAND.

P. Moutan, *P. albiflora*, *P. anomala*, *P. arietina*, *P. decora*, *P. Californica*.

PANSIES.

Pansies have been grown for years, under the name of Heartsease, in all gardens, in the temperate and sub-tropical zones. No capital, such as demanded by orchids, for instance, is required to produce flowers of wonderful diversity in colour and marking which the different flowers exhibit, and the ornamental and floriferous habit the plants assume. Even those who are not sufficiently interested in pansies to grow a collection of named varieties, may procure a packet of mixed seeds, and raise any quantity of plants, that will be scarcely less ornamental for the hardy flower garden or mixed border.

PROPAGATION.

Pansies are readily multiplied by seeds, cuttings, and sometimes by layers. Seeds may be sown at almost any time of the cool season, but as planting-out is best performed in spring or early autumn, it is advisable to sow with a view to preparing plants for these two seasons.

The best way to raise plants is to sow the seeds in shallow boxes in the same manner that small seeds are raised by horticulturists. The box must be filled with light sandy loamy soil—a good light garden soil will do very well. Make the surface perfectly smooth, and scatter the seeds evenly on it. They must not be covered deeply, and, to avoid this, sift some light soil over them, covering them to a depth of less than one-quarter of an inch. This done, give them a very gentle sprinkling of water, and set the box in a sheltered situation. In about a week or ten days the little shoots will appear above ground. Then, when watering is required, it must be done from a very fine-holed watering can. When the plants are from 2 to 3 inches high, they may be set out. Always, if possible, choose a dull day for doing this. The permanent bed must be deeply dug, and the soil rendered mellow. Set the plants out about 8 inches apart each way. In less than a couple of months they will be in flower, and will continue to bloom until next autumn. The soil must be regularly worked, and plenty of moisture should be supplied. It is a good plan to give them a little liquid manure occasionally to help them along. If flowers for exhibition are required, only about four or six main shoots should be allowed each plant, others being pinched off occasionally as they are formed. All blossoms should be picked off regularly to prevent the formation of seed pods, which naturally weakens the plant, and to increase the size of the flowers. With very slight care lovely little beds of pansies can be raised, even by the children of the house, whether in town or country. All children love flowers, and every encouragement should be given them to engage in such a charming occupation as simple flower-gardening.

What should a good pansy look like? is often asked. The florists demand that a pansy, to be perfect, must have a round outline, flat and very smooth edge, petals thick and velvety, the three lower petals alike in their ground colour, the lines and markings in the centre bright and distinct, the two upper petals (which always differ in colour from the others, except in solid colour sorts) perfectly uniform, and the flower to measure at least 1½ inches in diameter.

VARIETIES OF THE PANSY.

The number of varieties may be said to be legion, so great a variation in colour and markings do the plants represent. There are two sections into which pansies are divided—namely, fancy and show; and varieties of the latter are further subdivided, according to the colour of their flowers, into three classes, termed, respectively, Sells, White Grounds, and Yellow Grounds.

The Sells are either black, maroon, primrose, white, or yellow. White Grounds have a large, central, dark blotch round the eye, then a ring either of white or cream colour, and an outer band of bronze, purple, or maroon. Fancy, or Belgian pansies, have various colours and tints curiously blended in their different flowers, the petals being blotched, flamed and edged, and quite distinct from those of the show section. A third section is sometimes made of bedding varieties. These are usually self-coloured, and are distinguished by their compact and floriferous habit, and, as a rule, small flowers. They are more generally known as *Violas*. The line of demarcation, however, between a *viola* and a pansy is now practically undefinable.

SOME FINE PANSIES.

Bugnot's Exhibition.—This splendid French variety is, without question, the most striking one ever raised. Immensely large, of the Giant Odier type, the surface covered with fine hair-like lines.

Odier, or Blotched; Belgian, or Fancy; Giant King of the Blacks; Giant Trimardeau.—Some of the flowers of this distinct and beautiful class have measured 4 inches in diameter; Fire King, Danish Exhibition, &c.

VIOLETS.

Like the pansies, the garden violets have been derived from the viola, of which there are a great number of species. The only ones, however, which are cultivated by horticulturists are the garden types which have been derived from the indigenous British sweet violets. Great improvement has been effected in this charming perfume flower, in increasing the size of the bloom, and introducing more varied colouring into them, without diminishing the characteristic perfume. The single varieties, in particular, have been improved. The double-flower violets have been produced from a variety of the common violet, the Neapolitan. The double types, though not as hardy as the single kinds, are also popular garden plants, flowering freely under suitable conditions. The flowers are delightfully fragrant, the perfume in many varieties resembling that of the wall-flower.

The violet thrives admirably everywhere in the Southern districts of Queensland, and particularly on the Darling Downs, where large quantities are grown for transmission all over the State. Although the plant can stand a considerable amount of heat, it will only thrive in our tropical North under the most careful conditions of cultivation.

The violet succeeds best in a fairly heavy soil that has been deeply worked and moderately manured. An excessive quantity of nitrogenous manure will cause the production of an excess of gross foliage and very little bloom. The usual position assigned to violets is that of edging plants, for which purpose they are specially suitable. The single-flowered varieties will thrive in any aspect excepting an excessively shaded one, but the double varieties require a rather shaded position unless the soil is cool and moist. Red spider is the principal insect pest of the violet, and is difficult to exterminate, owing to its attacking the under surface of the leaf. When the plants are badly affected, the leaves become yellow in colour, and should be cut off and burned; in the case of plants newly set out, the application of water is necessary.

Violet plants bloom freely for two seasons, after which they become weak and straggling in habit, and the flowers produced are poor and few. The plants should be renewed after the second year, fresh soil being necessary to ensure success. Strong sturdy runners, with roots attached, should be selected, and planted either in the spring or autumn. The plants should be mulched with rotten manure early in summer.

I have adapted the above, to a great extent, from a paper on the subject in "The Australian Gardener," by J. Cronin.

Violets are propagated chiefly from runners which are freely produced by the parent plants. Five or six of the strongest should be selected, and the points pinched off; all succeeding runners must be cut out, so as to throw as much strength as possible into those selected for transplanting.

SOME GOOD VARIETIES.

Double-flowered: Neapolitan and De Parme, mauve; Marie Louise, lavender blue; New York, violet; Lady Hume Campbell, mauve; Count Brazza, white; Madame Millet, rose; and King of Violets, dark blue. Single-flowered: Admiral Avellan, White Czar.

A FLORAL MIRACLE.

'Under this title the "American Farmer" tells of the production of an improved variety of the cactus dahlia. The writer is evidently not very well posted as to flowers; he speaks as though the cactus dahlia was a new thing,

when it has been offered by florists for several years. Probably the new variety is an improvement on any which were in existence before, still they were well worth cultivating all the time.

Great are the achievements of the floriculture experiments. Things beautiful are made still more beautiful, and unlovely things are deprived of their ugliness. Burbank takes the cactus in hand with its prickly leaves and forbidding thorns. The wand of genius touches the plant, and behold a transformation excelling the utmost achievement of Aladdin. The thorns have disappeared, the harshness is all gone, and we see before us a plant not only harmless but useful. A Chicago florist, completely reversing the process, puts thorns on the gentle dahlia. They are not stiff and stinging, however, and that would be a calamity instead of improvement. The petals have simply been transformed into floral needles which, in general appearance, with the exception of the rich colouring, bear a striking resemblance to the thorns of the desert plant. Thus the cactus dahlia emerges as the latest floral wonder, a witness extraordinary of what can be done by man operating along the lines of evolutionary science.

This floral miracle was evolved through elaborate culture processes at the Vaughan hothouses in Western Springs. It has been grown in three principal colours—yellow, scarlet, and pale-pink. At the Coliseum show last November it received "osthetic homage" from all flower lovers who attended the exhibition. An enthusiast wrote—"The fluffy chrysanthemum and other old-time favourites will have to take back seats in presence of this new flower queen, certainly until the novelty wears off. Even the peerless American beauty rose and all her lovely sisters will have to step aside while the cactus dahlia passes with her wondrous new equipment of needles. The band will play "Hail to the Chief," the ushers will bow obsequiously, and the chorus will sing hosannas in praise of the new wonder that attests the supreme achievement of experimental genius. By all means Burbank should be invited to come and bring his dethorned cactus to be placed beside its more civilised sister. Then it may be explained how the needles taken away from the cactus have been transferred to the dahlia without their sting and offensive qualities. The occasion will be one of wonderful interest, not simply for flower lovers or the general multitude, but for all scientists and others interested in these famous illustrations of the truth of Darwin's theory as set forth in his epoch-making book on the "Origin of Species." In this publication, which was the greatest achievement of the nineteenth century, and most far-reaching in its results, was for the first time unfolded one of the most interesting secrets of Nature. It explained elaborately the processes by which an original type—either animal or vegetable—was differentiated into species. The operations were all under the natural law, and long periods, sometimes ages, were required for Dame Nature to do her work. But once possessed of her secret, man may step in and facilitate the process. He can take short cuts and push things, thus accomplishing with comparative speed what in Nature requires so much time.

Much has already been accomplished for agriculture by taking advantage of the Darwinian knowledge and pursuing the Darwinian methods. It is in this way all the new grains, new fruits, new grasses, and new flowers have been produced. Burbank used the method in taking the thorns off of cactus, Vaughan used it to transfer them in modified form to the dahlia, and every breeder who has given us a new kind of cattle, sheep, or hogs has simply followed Nature as expounded by Darwin. Nothing can be done in opposition to the natural law; almost anything may be done by following it and artificially assisting the process. It can not be doubted that scientific agriculture of the future will depend for advancement and success upon the wonderful discovery of the kindly and gentle English philosopher. The possibilities of the process, patiently pursued, are limitless in the floral, horticultural, and

general agricultural world. To make our country worthy of the twenty-first century, to bring about the changes that will be necessary to enable our farmers to feed the teeming millions of the future, the brains of the inventors and experimenters will be kept busy.

SCHOOL-GARDENING IN THE PHILIPPINES.

Whilst school-gardening is in its infancy in Queensland, we find that it is made a serious business of in the West Indies and in the Philippine Islands. Following is an account taken from the report of Mr. North H. Foreman, supervising teacher at Lubao-Aringay, La Union, Philippines, on school-gardening in that province, published in the "Philippine Agricultural Review":—

Last year, during the month of January, a contribution list for the purchase of seeds was begun in each school. No assessments were made, and no amount stated as desired. As a result of this effort we soon had on hand P35 of seed money. I personally assured each pupil a garden and seed for the same. Every teacher was required to keep a list of the names of all pupils who contributed, and the amount. This list is filed in my office, and is now used in the distribution of seeds to pupils for home gardens. In no case was there a contribution of more than 5 centavos, and the most of the contributions were 2 and 3 centavos each. Eggs, cocoanuts, pineapples, &c., were accepted, and sold in the markets. The sum raised was spent chiefly with a firm in Chicago and one in Los Angeles, for the purchase of about 50 lb. of seed, which arrived by mail during the month of May. The seeds consisted of seventy-four varieties, many of which were unknown in the Philippines. I found it advantageous to buy in bulk, as in this way you get many more seeds for a given amount of money, and many of our varieties were received in $\frac{1}{2}$ -lb. and $\frac{1}{4}$ -lb. packages. The seeds were divided among the different barrios, according to the amount of contribution, and all schools have had many varieties to give the pupils for planting at home.

As a means of encouragement, I shall offer a prize to the pupil who raises the finest specimen of each thing planted. Pupils are permitted to submit in this competition products from their home gardens, as many of the pupils have home gardens, which I personally inspect and encourage as much as possible. If a pupil can produce better plants in his home garden than we do in the school garden I want to know it, and also how it was done.

I now have on my hands one more garden in Tubao than was desired. The first-grade pupils were told that they would have no garden, as they were too small. This announcement brought forth requests, petitions, and a few tears, until I told the children in this grade to go to work. To have seen pupils seven or eight years old carrying bamboo and working their plots would convince anyone that the Ilocanos are agriculturally inclined.

A garden is now found at every school, and is part of the school work. The central school of Aringay has an excellent flower garden, containing many beautiful flowers; also some experimental plats, and a vegetable garden. The central school of Tubao has two large gardens. All of these gardens are located near the schoolhouse—in most cases adjoining the schoolhouse.

The general arrangement was to assign a certain part of the garden to each class, the teacher in charge of the class also having charge of the garden. I found that awakening a certain amount of class rivalry, lent interest to the work. In the central schools the teachers have immediate charge, but in barrio schools each class chooses a leader, the teacher having an oversight of the work. This was found necessary, as the barrios contained but one teacher each.

The part of the garden assigned to each class was subdivided, and each member of the class was given a small plat. That plat was his. He planted

what he liked, and all the work in preparing the ground and cultivating the plants was done by himself. This arrangement gave each individual pupil a definite ownership. In the assignment of plats both boys and girls were included.

PREPARATION OF GARDEN.

No difficulty was experienced in securing the necessary land, and I found it best to build with school labour the fences required. Each pupil in the school donated a portion of the bamboo needed, and the older boys, under the guidance of the teacher, built the fences.

Every garden in my district was fenced by the pupils. These fences were built in July, after which no more "general" work was done, each pupil being interested in his own plat and working on it alone. As the rains are heavy, borders were placed around each plat. These borders were made of rock, brick, bamboo, or sod, the material that was most plentiful in the barrio being used. Numerous wide paths were made so as to give the pupils ample room for their work without stepping on the beds.

FERTILISERS.

The kinds and uses of fertilisers were taught, and each pupil was required to fertilise his own garden, some of my best gardens having been on worn-out land. The pupils carried fertiliser in baskets from their homes. After the ground was prepared to a depth of 8 inches, the seeds were planted. In order to give needed instructions in the preparation of seed beds a part of each pupil's garden was used as a seed bed.

CARE OF GARDEN.

Each pupil was required to have at the school some vessel for carrying water. Some of the schools had water close at hand, and in others it was necessary to carry the water nearly 1 mile. The girls usually brought water in jars, while the boys used a long bamboo; in two barrios nothing but bamboo was used. Each school had one or more sprinklers. Some plants required daily watering, and others were watered once every two days. On Saturdays and other holidays a committee was chosen from each class to water the class garden, but many pupils preferred to come and water their own plat rather than trust a committee.

RESULTS.

When the products were ready to be used the pupils were encouraged to take them home, each pupil having been previously instructed in regard to their use. Many a proud boy or girl trudged home with three or four radishes, beets, or turnips, but no pupil was permitted to take all of any one kind from his garden. At least one plant was left for seed, each pupil being required to save seed from each kind planted in his garden. This seed was divided into two equal parts; one part for the pupil, the other to be kept for the school garden next year. Pupils were taught that saving of the seed was quite as essential as the planting of the garden.

I will not attempt to attach a list of all plants that were grown in these gardens, but the following is a general summary:—

| | Varieties. |
|---|------------|
| Aringay: | |
| Vegetable garden | 52 |
| Flower garden | 126 |
| Experimental plats | 12 |
| Cava: | |
| Vegetable garden | 20 |
| Santa Cecilia | 37 |
| Tubao: | |
| Vegetable garden No. 1 | 30 |
| First-grade vegetable garden No. 2 | 50 |

| | | | | | | | |
|------------------|-----|-----|-----|-----|-----|-----|----|
| Santa Tereza : | | | | | | | |
| Vegetable garden | ... | ... | ... | ... | ... | ... | 35 |
| Rizal : | | | | | | | |
| Vegetables | ... | ... | ... | ... | ... | ... | 29 |
| Anduyan : | | | | | | | |
| Vegetables | ... | ... | ... | ... | ... | ... | 27 |
| Ambangonan : | | | | | | | |
| Vegetables | ... | ... | ... | ... | ... | ... | 18 |

Experiments were made in the experimental gardens with the following :—

Broom corn: Grew well, and had good long brushes. Winter wheat: Grew well, good head. Flax: Grew well, good stem and plenty of seeds. Spring wheat: Grew fairly well. Buckwheat: Grew well, but did not get large. Millet: Grew well, good head. Rutabaga: Grew well, good root. Sugar beet: Bad seed. Sugar corn: Only fair stand. Sunflowers: Large heads, some 18 inches across. Sage: Grew well, but was killed by animals. Peas: Failed, few pods.

INTEREST SHOWN.

In no case have I any complaint to make of lack of interest shown by pupils. All of the pupils were willing to work, and felt slighted if not given a garden. As an example, I give the following occurrence in Tubao: It was first intended to have only one garden in Tubao, and have only second, third, and fourth grade pupils do garden work. The first-grade pupils objected to this arrangement, and many in this grade cried when told that they would have no garden. I finally told them that they might have a garden if they would bring the materials for fences. The next morning every pupil came to school with one or more bamboos. Even little fellows seven years old brought a long bamboo. The larger boys of the grade built the fence. A corner of the plaza was utilised, and in three weeks every pupil in the school was working in his individual garden. Absolutely every pupil in my district does garden work.

In most cases the teachers have shown great interest in this work. With possibly two or three exceptions, the teachers have carried out my instructions, as the flourishing gardens show.

The parents have shown a creditable amount of interest, often visiting the gardens. In only two cases have I had parents object to their children working in gardens. These objections were easily settled by a little explanation as to the individual ownership of the gardens.

I find that the hardest problems I have had were the stealing of the plants from the gardens and insistence upon frequent waterings. The barrio of Cava being on the main road, and no houses near the gardens, the plants were stolen by people who were passing. I also had considerable trouble in the barrio back in the hills among the "bagos." The barrio of Ambanganon was constantly depleted by thieves. There was also some difficulty in getting teachers to give minute attention to all detailed instructions about the watering of plants.

SUMMARY.

First.—The garden work was done willingly by all pupils.

Second.—Attention was given the gardens on Saturdays and holidays.

Third.—All gardens were owned by the pupils, and the products were the property of the pupils raising them.

Fourth.—Instruction was given in the use of fertilisers, cultivation of plants, use of products, and the saving of seeds.

Fifth.—Garden work was done outside of school hours.

Sixth.—It is believed that the gardens have been a success, and a great benefit to the pupils in teaching them industry, and to the parents and the community at large by the introduction of new food plants.

Seventh.—All that is necessary for a good school garden is plenty of hard work and close supervision on the part of the supervising teacher.

Eighth.—Previous to the starting of our school gardens, radishes, lettuce, beets, endive, carrots, rutabaga, kohlrabi, turnips, and many other of the plants grown, were unknown as food plants in my district. Now you will find many of these planted at the homes of the pupils.

Ninth.—The only restrictions were that each pupil prepare the soil, cultivate the plants, and save seeds according to instructions. The success of the work I attribute largely to the fact that each pupil was given his own individual plat, thus giving him a definite ownership, and a right to use or sell the products of his garden.

THE SCHOLARS' GARDEN, AND WHAT WAS DONE WITH IT.

By A. C. NEATE (late Melbourne Botanic Gardens).

PART II.

Though the address to, or talk with, the Malvern scholars was given as an extempore narrative, the notes (Parts I. and II.) were retained, so as to be elaborated later in M.S. But the texture of the wording has been somewhat departed from, added to, or varied throughout, so as, perhaps, to be made more helpful in fostering or maintaining a spirit of floral enthusiasm in the minds of all the juniors who heard or will read the same; many of whom, it is hoped, are interested readers of the "Queensland Agricultural Journal"—with special reference to the items treated upon under the "Farm and Garden," with other profitable notes and illustrations in its pages.

It is of interest to the writer to find that the veteran and highly-esteemed Government Botanist, F. Manson Bailey, Esq., F.L.S., is still actively continuing his literary labours, and gives evidence thereof month by month, with illustrations, in the "Queensland Agricultural Journal," under "Contributions to the Flora of Queensland," which will well repay perusal by both young and old, making the lovers of botany and horticulture everywhere his thankful debtors.

Now, for the continuation of these notes, published in the April issue of the Journal:—

"Autumn time is now upon us, with occasional breezes of icy chilliness, and we are rather glad that in the main the fiery sunbeams have been quenched, though we rather regret the lessened floral display occasioned. Let us, however, hear what that hitherto silent, but energetic, brother Frank has to say in continuation of what his sister (Flora) told us previously (pp. 179-181) as to their work, and its results:—

"Our Virginia creeper plants have been much admired, and the foliage, which has been rather scorched by the heat, gave a good deal of rich colouring, and we still have plenty of drooping pieces of the younger leaves; but the best festoonings are on the front of our family home, and we are told they are much admired by passers-by.

"This being the time for chrysanthemums, and we have but a few in our garden, we went with father to see Mr. Pockett's many choice examples in the lovely public gardens (North Malvern). What splendid blooms! some of them fully 6 inches across, and in many variations of colour, all so carefully grown, well-staked, and protected, but so placed that we could stand on the sward quite close to them. My sister and myself hope, in time, to find room for a few very choice varieties in addition to our own, but not so large in the trusses as Mr. Pockett's; smaller flowers suit us best to cut from for the house, or for bouquets to give away.

"We hope in a month's time to have an additional bed ready for, say, roses and chrysanthemums in the main, which father is causing the young

garden to trench and enrich with decayed leafage, farmyard manure, &c. But, on the whole, we prefer a mixture of various plants, so as to give variety of colour, both as to foliage and blooms, and varying with the seasons. All will, we think, depend on circumstances; but we are always taking mental (or other) notes of the successes of our friends, so as to make, perhaps, helpful improvements to our own little garden.

"It will perhaps interest our 'brothers and sisters,' or, rather, 'cousins,' in Queensland, if we quote a few of the suggestions which Flora and I took count of at the school lecture:—

"1. To take a few visits to interesting groupings of flowers and foliage plants in any local private or public gardens to which we may find it convenient (with permission as to private places) to go on, say, Saturdays or holidays, or after school time on other days. Many of the private gardens here are very tastefully laid out—viz., something after the beautiful Melbourne Botanic Garden style of lawn and parterre insertion; the lawns here being often of buffalo grass, and sometimes of Kentucky blue grass; or, as in the Malvern public gardens, of both kinds intermixed. If we can get father to accompany us on some of our visits, we can be sure to profit more by having his naming of the trees and shrubs, he knowing more than ourselves as to their native countries, habits of growth, suitability for useful positions in either our friends' grounds or for our own smaller opportunities.

"Well, we frequently visit the beautiful Malvern Gardens; they have been but eighteen years in existence, and yet they abound in fine tall examples of well-grown ornamental plants. Many, certainly, are too large for a scholars' garden—say, such as *Brahea filamentosa* (threaded fan palm); *Phoenix canariensis* (Canary Islands' date palm); *Cyperus papyrus* (Bullrush, or paper plant of the Nile, fine tall, and thick clumps in the plant groups); giant and thick, as well as slender-stemmed bamboos; a fine avenue of *Quercus robur* (British oak); a fairly large example of *Q. Lusitanica* (Portugal oak); and near by are some specimens of *Jacaranda mimosifolia* (Rosewood of Brazil). This last has very fine pinnate leaves, and in summer yields large masses of sky-blue flowers.

"Then there are the rock pools, with very choice examples of *Nymphæas* and *Nelumbiums* (water-lilies), also other water-loving plants, and gold-fish.

"Of course, we visit the roses; they are in good variety, but they had much to contend against last summer from both the 'thrip' and the heat.

"We have the privilege, by invitation, to visit the splendidly-equipped garden of our courteous neighbour in the same avenue, Herr de Chanéet, who, as a well-known professor of music, finds quite royal entertainment for his special 'off' days—viz., Wednesdays and Saturdays, in cultivating a very large and varied collection of roses, climbing, standard, and half-standard specimens. He has fully 500 of these, and over 300 separate kinds, inclusive, and all named. They receive what father calls 'intense' cultivation. The results are marvellous. Belle Siebrecht is one of his best bloomers. Just now others could be named out of this (mainly) tea-scented collection, but *cui bono*?—they must be seen to be enjoyed—with the professor at your elbow!

"Just outside of and opposite to the Malvern Gardens gateway, we saw a fine tall specimen of several years' growth, in a private garden, of the *Musa ensete* (Bruce's Abyssinian banana). Here it stands both the hot winds and frosts very well, being so well protected by its connection with the dwelling, fences, &c.

"2. To visit the Melbourne Botanic Gardens is always a great treat also. Here, our father tells us, are fully 100 acres—(they were commenced in 1846, with 5 acres!). The whole plan, as now paramount, is almost completed by the present director, Mr. W. R. Guilfoyle, who, thirty-four years since, commenced to remodel them. There are now probably over 40 acres of sloping lawns (buffalo grass); classified and promiscuous groupings having been cut

out in the sward, whilst the picturesque features have been largely advanced, as to interconnection of land and water, by the bold and well-planted rockeries, and the effects which have been produced by colouring, with both foliage and flowers, are very apparent. There is one large lake of, say, 14 acres, well studded with islands, all planted, and a new (artificial) lake is now charged with the duty of conserving quantities of water-lilies and other choice aquatic plants.

"One fact alone, our lecturer said, makes these gardens more deeply interesting—viz., that thousands upon thousands of plants are fully labelled with both common and scientific names, native countries, relationships to other plants, &c.; and we intend to repeat our visits there on many future occasions, so far as opportunities admit, though we cannot expect to reproduce either this effect (bold planting) or that contrast (colour or blend), yet we will be sure to annex a fact or so that will both entertain and give us pleasure, enlightening us too when thinking about tending, or otherwise improving, our little Malvern garden.

"The time for visiting other places being, we are sorry to say, for the present, exhausted, we must proceed to give a few added facts which may possibly be of interest to other learners.

"It must not be supposed that we have arrived at perfection—that we pose as possessing a model garden (!) free of weeds and all litter. Oh, no! our imperfections are too apparent; still, we must do the best possible to gradually prepare the soil for the reception of nourishing composts from our heap of decayed leafage and manure, &c. The leaves of deciduous foliage will soon have fallen, the stems of past flowered plants will have to be removed, say, by the end of the month, or soon after that; and the roses may by then be judiciously pruned; then may follow the final digging and trimming up. The lawn of Kentucky blue grass plots, apart from our own garden, are, of course, mown as often as required throughout the seasons.

"We have in our front (home) garden, facing west, and exposed a good deal to the summer afternoon sun, a few—very few—roses. La France is one of the best to stand the blaze of heat, and has been flowering almost all the time for the past six months, and we wish we could quote as our own a plant or so similar to, and in as good a form, as one of a respected neighbour's. What a splendid 'buff,' warmed up with a fine pinky tinge—viz., Catherine Guillot. It stood the sun quite as well as La France, and is a still more magnificent bloomer! We hope, with father's help, to have it budded on to a Banksian climber (we have been promised the buds), and what a splendid effect would be apparent in due time on our veranda pillar! He tells us, though, that for a variable soil like ours that the success would be still more marked had we a similar habited plant of *Rosa fortuneana* to bud it upon, as this free grower stands very well in rather poor, and even gravelly, soil, better than most roses. One of our neighbours has W. A. Richardson growing on this stock. We have this fine rose, but on its own roots, the two Maman Cochets, Safranot, and some others, including Madame Lambard, *Devoniensis*, dwarf and climbing varieties. As to cuttings of roses, if one wants them to callus and root freely, the best time we find to put them in—as short-jointed examples—is during May or early in June, whilst the ground is still warm.

"Our stock of bulbous and tuberous plants, too, is very limited, and can be counted on the fingers—viz., lilies (*Lilium lancifolium*, *L. auratum*), *Gladioli*, and *Vallota purpurea*, all of which did rather badly in the summer, and will need special nourishment (especially the *L. auratum*). We had fair success last winter with a pretty tuberous plant (*Lachenalia tricolor*), and our new stock of plants are well up, showing their tongue-shaped and spotted leaves, and in a few weeks will give us freely of their golden waxy-yellow and coral-red bell-blossoms, both in the open ground and in a pan or pot for outside the window-sill. These tubers were kept dry all the summer, but asserting

themselves by bursting into growth, were planted two months ago. My sister attends to all the indoor and some of the window plants, but they are of the usual well-known kinds, and I will not name them here, except to say that Queensland is represented in our home by examples of the 'Bird's Nest' fern (*Asplenium nidus*) and 'Elk Horn' fern (*Platycerium alcicorne*), also of a palm lily (*Cordyline terminalis*); the latter is proved specially suited for pots in a young state.

"The advice given in the lecture, and of which we had other evidence, has been adapted to our own little plots, although our 'Home' garden was long since taken in hand on rather similar ideas, viz. :—

"(a) On the north and west sides of the house, with sunny exposure, our father and the rest of us put in here, and retain plants of the Cactus and Aloe family, which last includes that pretty trailing and golden-yellow flowered *Aloe ciliaris*; then Echeverias, Mesembryanthemums in variety, also other fleshy-leaved plants, not forgetting the great variety of bloom we had all the summer given on our rocky edgings and points by the many-coloured Portulacas (*grandiflora*); and they, being only annuals, have ceased to be, but their successors in scores will come up freely after spring begins, to be transplanted at will.

"The perennial Asters (blue-flowered) and *Agathæa cælestes* (blue daisies), also *Cineraria maritima* (Dusty Miller), and *Centaurea argentea* (Silver Leaf), as well as an uncommon—but by no means new—plant of shrubby habit, *Salvia involucrata*, having cheery red florets (coral-like) standing well out from the plant.

"(b) Then, on the shady south and south-west sides we grow hydrangeas (including a fine silvery-leaved kind); five or six good cannas; *Aralia (Fatsia) papyrifera* (rice-paper plant), with its large palmate leaves; *Arundo Donax* var. (Silvery Bamboo-reed); *Cyperus papyrus* (Nile paper-reed); *Acanthus mollis* (Corinth-column plant)—just below its cast-metal copy on veranda pillar; cowslips, primroses, and fuchsias, ferns, variegated ivy, vinca (variegated perriwinkley), forget-me-nots.

"(c) Generally, as to annuals and small perennials, father prefers us to follow our own experience, but in the main to sow only in the spring time (September), either in the open ground, or, if wanted earlier than that, in boxes set in sheltered positions, proof against extremes of weather. A shelter-house of branchlets (tea-tree) or canvas, or, better, a small greenhouse, or even a glass-topped frame, would aid us very much for seedlings, cuttings, and tender plants in a young state. The next best thing, if early displays are needed, is to do, as we have often done in times past, buy straight off small lots of annual seedlings for spring planting (supplementing our own) from any reliable dealer in plants or from a nurseryman. These notes are penned as giving the experiences of both FLORA and FRANK."

SOOT AND COAL ASHES.

Save all your coal ashes and sift same. They are no use as a fertiliser, but for lightening heavy soils are invaluable.

Let no soot go to waste. Save all you can handle, and place same in a coarse bag, for making liquid manure for chrysanthemums, dahlias, ferns, and any flowering plants. Thrown into a barrel with moist sand, and, worked up together, you get a mixture invaluable for grubs, slugs, and cutworms. Strew the sand and soot around the stems of any thing in seedlings you wish to save.

Market Gardening.

THE FRENCH SYSTEM OF MARKET GARDENING.

A discussion has been going on in England, and many inquiries have been made, about the French or *Maraicher* system of gardening. It originated from a visit paid to a 5-acre farm at Thatcham, in Berkshire, which is one of the few places where the system is being attempted in England. A French gardener had been brought over by the two ladies who set up the farm, in order to demonstrate the great value of the system. A Press representative, who had some conversation with the French gardener, and inspected his garden carefully, writes as follows:—

It is exactly on the model which every horticulturist should have studied, and every traveller will have noticed outside Paris, and there is a good chance that it may be developed in England. An account of the system was given the other day at a small holdings meeting in Berkshire, and as a direct result neighbouring villagers are beginning to follow the French methods.

“Mud, I call this mere mud,” said the Frenchman, when complimented on the wonder of his soil. “You should see it in a year. It will be as black as a black hat.”

The French garden land is as black and rich as it is painted, and it is brought to its pitch of richness by methods that are within the reach of anyone who is within reach of stable manure. The top spit, or spit and a half, of original soil is taken out and put in heaps. A small portion of it is then mixed with the “shortest” manure, with the sort of thoroughness that a mason mixes his lime and sand.

THREE SIMULTANEOUS CROPS.

This layer of fine rich soil is laid on the top of a level foundation of manure covering the whole acre, half-acre, or whatever it may be. A great part of this surface is covered with glass, either in the shape of bell-jars, known as *cloches*, or lights, which are frames made more economically and much more neatly than you see in England. The frames are at certain periods protected during the night with rye grass mats. In the frames underneath the bell-jars, and in all the uncovered spots between them, the seeds are sown, very often broadcast, and frequently three crops simultaneously.

The succession is quicker than even a skilled English gardener will well believe, and strong plants may be grown astonishingly near one another. The carrots come up before the lettuces are cut, and early greens; carrots and lettuces may all be growing together in one frame.

The Frenchman simply works with the top little bit of soil. No deep digging is required, and the labour is light though continuous. Each year an inch or two of the manure is being converted into mould of such preciousness that a gardener contracts for leave to carry it away—18 inches of it—with him at the end of his tenancy. The heat underneath and the glass above enable the gardener to grow everything before its season, and the economy of space is such that a quarter-acre can bring in a fair living.

WONDERFUL MOULD.

An inch or so of the used-up soil is got rid of each year, but even in its used-up state it would be considered wonderful mould by the ordinary gardener. It is made good, of course, by the addition of stable, not farm-yard, manure.

The French gardener is convinced that oven half-acre plots, especially if a number could be co-operatively organised, would pay large sums if in the

neighbourhood of any large town. Cottagers in a village, with a few lights and frames apiece, could also make considerable profit and supply early vegetables, now chiefly purchased from abroad, if their produce were co-operatively collected and marketed.

A visit to a Maraicher farm or a lecture would first be necessary. The French have been perfecting their method for two centuries. The making the soil quite perfect is a question of minute detail, but the first principles may be understood at a glance, and what the French call "the extravagance of perfection" can be got by practice.—"Australian Field."

TO MEASURE MAIZE IN THE BARN, POTATOES IN THE PIT, AND HAY IN THE STACK.

Two cubic feet of good, sound, dry maize will make a bushel of shelled grain. Therefore, to find how much grain is contained in a barnful of husked corn, find the cubic content of the barn, and divide by 2 for the number of bushels of shelled grain.

Suppose the barn to be 30 feet long, 12 feet wide, and 8 feet high, and packed with husked corn.

$$30 \times 12 \times 8 = 2,880 \text{ cubic feet.}$$

Divide by 2, and you get 1,440, the number of bushels of shelled grain in the barn.

In the case of potatoes in a pit, or of hay in a stack, make the same multiplication, and divide by 8 for bushels of potatoes, and by 512 for tons of hay (to the eaves of an oblong stack).

EXPERIMENT PLOTS.

The "American Farmer" says that down in Oklahoma farmers are forming "acre clubs," each member taking 1 acre for an experimental crop, doing his best with it, and, when the season is over, reporting his experience, inclusive of mistakes, and describing his methods. This is the most practical form of agricultural education, and the plan might well be adopted elsewhere. Few farmers are so skilled in agricultural science that they cannot learn something from their associates. The Oklahoma plan is a kind of extension of the experiment station, a reproduction in miniature of the individual farm of the principals governing the stations. It is a most excellent idea, and, if generally carried out, will prove of great educational benefit.

[If the same plan were adopted by the farmer members of Queensland Agricultural Associations, the educational benefit would no doubt be universally recognised.—Ed. "Q.A.J."]

THE CAPE "MORGEN."

Writing on the subject of the cost of destroying prickly pear, in the issue of this Journal for November, 1907, we mentioned the fact that the area of land infested by prickly pear in Cape Colony amounted to 500,000 morgen, and that the Cape farmers reckoned to clear it at a cost of 5s. per morgen. Naturally, Queensland farmers wanted to know the size of the morgen. All we could say was, that this measure of land has varied considerably in extent. A Prussian morgen is equal to 0.631, or something over 3-5th-acre; a Hamburg morgen was 2.38 acres; a Dutch morgen, 2.0076 acres, in Holland. The Dutch introduced the word into South Africa. Since the above was written, we have received a memo. from the Department of Agriculture, Cape Town, office of the Government Entomologist, to the effect that a Cape morgen is reckoned equal to 2.11654 acres. Our correspondent added that 5s. per morgen for destroying prickly pear is an absurd estimate.

Tropical Industries.

COTTON-GROWING.

Towards the end of next month, or even earlier in warm districts, the sowing of the cotton fields should be begun. We have so often pointed out the value of this crop to farmers, that it would seem superfluous to dilate upon the profits to be derived from it any further. That these profits are not imaginary has been proved practically during the past three years, and at a time when this Department undertook to gin the farmers' cotton, and guarantee them a certain price for it, the average yield per acre in money value was £9 all round, some farmers obtaining more, and in two or three cases the seed cotton brought the growers from £12 to £14 per acre, and in one instance the return was £17 per acre. Cotton-growing has its advantages and disadvantages. The advantages are that Uplands cotton is only a six months' crop. Within that time the entire crop should be harvested, and the land prepared for wheat, barley, oats, tobacco, onions, and market garden crops. Once the shrubs have covered the grounds, no further cultivation need, or indeed can, be done without damage to the branches. When the bolls begin to burst, picking may be begun, and a considerable quantity may be gathered in the early part of the season by working only three or four hours a day. In the height of the season all hands must be employed in getting in the crop. It has been stated that cotton should be picked as soon as the boll bursts, but experience has shown that it may remain for several days unpicked, without detriment to its colour or texture. Should, however, heavy rains occur, it is well to get the cotton in as soon as possible. Another advantage is, that cotton-picking is light, easy work, which can be undertaken by boys and girls, who, with a little practice, make excellent pickers, and in a well-grown field they can easily pick from 60 to 80, and up to 100 lb., of cotton in a short day, for which work $\frac{1}{2}$ d. per lb. is paid. It may be said that cotton-picking would interfere with school work. It need not necessarily do so. In the older days of cotton-growing in Queensland, the children attended school as half-timers, and in some districts the school holidays were so arranged that no school time was lost during the year.

In the case of Sea Island and Caravonica cotton, when the crop has been gathered, the plants may be close pruned to within 1 foot or 18 inches of the ground. They will then shoot out very early in the following season, and produce a crop six weeks earlier than if seed had been sown. This pruning may be done for three seasons, after which it is advisable to plough out the old plants and sow afresh. A further advantage connected with cotton is, that when it is picked and left for a few hours in the sun, it may be bagged or baled, and sent to market; unlike maize, which, after it is picked, must be husked, dried, threshed, and winnowed before it is ready for transport. For cotton there is always a certain market. It is impossible to produce too much, at all events, of Uplands—*i.e.*, short-staple cotton. The Manchester cotton spinners use comparatively little Sea Island, but can never get enough Uplands. There is no need for the farmer to look abroad for a market. Every ounce of cotton grown in Queensland can be sold in Brisbane at full market price, Messrs. Kitchen and Sons having erected ample ginning machinery, and the firm is a buyer of any quantity of seed-cotton.

Now, about the disadvantages attending cotton-growing. The most serious disadvantage is the pest known as the boll-worm, which bores holes in the bolls and utterly destroys the fibre. It is the same worm so frequently seen in the heads of maize cobs. The fact of its attacking maize has led to

the use of the latter as a trap crop, and it has been demonstrated that where maize has been planted, between every 25 rows of cotton, in 5 rows consecutively the cotton has been saved, owing to the boll-worms attacking the maize, which was carefully cut and burnt. One row should be planted first with early-maturing sweet maize, and, when the ear-silk appears, careful examination must be made for the eggs of the moth, and when no more fresh eggs are found, the whole plant is cut down, and burnt or fed to stock. Three more rows are then planted, so that the silking time comes on about November. On these large numbers of eggs may be found. These must be allowed to come to maturity, in order to prevent the destruction of their natural enemies, which are parasitic on the eggs and on the worms. The crowded condition of the worms on these ears induces cannibalism to such an extent that few survive. No destruction of this corn is recommended until the whole generation has been parasitised. Then the fifth and last row is planted to catch the eggs of the remaining few, and these are destroyed by burning the ear-silk as soon as laying has apparently ceased.

The opened bolls are often attacked by a very gaudy-looking beetle or bug, but they do not appear to do much injury to the fibre.

I have never seen that cotton pest, known in the United States as the cotton-stainer, in Queensland, although I believe that some kind of beetle has occasionally been found which affects somewhat the colour of the staple. The terrible pest of the cotton fields of the United States of America, the boll weevil, has, fortunately, not made its appearance in Queensland. The Red-banded Gaborneria is, so far, the only beetle responsible for damage to the fibre, but its attacks are infrequent.

The cost of growing a crop of seed-cotton amounts to about £3 16s., including cost of cultivation and picking. A 2,000 lb. crop would thus be produced for about £5 17s. 8d., and the selling price at 1½d. per lb. for Uplands seed-cotton—viz., £12 10s., leaves a profit of £6 17s. 6d. per acre.

Some years ago (in December, 1900) I wrote in the issue of this Journal for that date, as follows:—

The cost of producing an acre of maize is £1 11s. 8d., and with a 40-bushel crop, and maize selling at 2s. 3d. per bushel, the profit is £2 18s. 4d. per acre. The profit on cotton is, therefore, double that on maize.

I also pointed out that the farmer who merely grows his cotton, picks it at ½d. per lb., and sells it to the gin-house owner, makes a profit of £3 2s. 2d. per acre, and if he picks the cotton himself, with the help of his family, he keeps the cost of picking (£2 1s. 8d.) in the family, so that he would actually be getting a profit of £5 3s. 10d.

As I have shown on previous occasions, other nations are preparing to compete with the United States in cotton-growing. Russia is rapidly increasing her acreage under cotton in Asia. Germany is determined to enter upon the industry in her suitable colonies. In what is called "Latin" America—that is, in Mexico, Brazil, the Argentine, Peru, Chili—cotton-growing is spreading.

Here, in Queensland, we have all the conditions needed for a large production, yet we grow wheat in places wholly unsuited to that cereal below the Range, producing in a good season an average of 20 bushels per acre, worth from £2 to £3, from which all the usual expenses have to be deducted. We grow maize, yielding 40 bushels to the acre, worth from £4 to £6, less expenses, often amounting to £2 per acre. And all these lands are capable of producing a crop which will give twice the profit of wheat and maize.

The cotton industry surely deserves a trial once more. Anyone farming from 50 to 100 acres in the Moreton, or any other district below the Range, could spare one or two acres as a trial. If the result prove unsatisfactory,

the loss is not very great, but the lesson gained would be invaluable. On the other hand, if it were successful, it would not be long before the lands now devoted to a few cows and horses in West Moreton, would once again be white with the fleecy crop, and Brisbane, Ipswich, Laidley, and other centres of farming operations would resound with the pleasant hum of the gins."

Over-production is not to be feared.

[Since the above was written it has been abundantly proved that the profit of £6 per acre is, if anything, under-estimated, as shown at the beginning of this article.]

In February, 1908, the imports of American cotton alone amounted to 3,111,667 bales, and although the National Ginners' Association showed a return of 10,593,000 bales, as ginned up to the 7th of that month, this had no appreciable effect on the market prices, which were from 5½d. to 6¼d. per lb. On 13th February, 1908, Queensland cotton was quoted in London, by Messrs. Slann and Davies, cotton brokers, at 7½d. per lb. for "good fair" and 7¼d. for "good."

NOTES ON COTTON-PLANTING.

1. Planted 4 feet by 16 inches, there should be 8,034 plants to the acre.
2. Seed should be sown in drills, not deeper than 2 inches.
3. Sow thickly as a safeguard against crickets, which destroy the young plants.
4. If the weather, though moist at time of planting, is not considered moist enough, the seed may be soaked overnight.
5. In rich soil two plants should be left together; in poor soil they should be 18 inches or more apart.
6. Thin out the weakly plants.
7. Keep the ground thoroughly cultivated, and as free as possible from weeds.

PICKING AND PREPARING FOR MARKET.

8. When picking, keep each kind separate, and mark it accordingly.
9. Thoroughly dry the cotton in the sun before baling.
10. The cotton is dry enough to bale when the seed will crack brittle between your teeth.
11. Pick clean and often, but avoid gathering unripe pods.
12. A little moisture in the early morning soon evaporates if the cotton be placed in the sun to dry.
13. A few days of wet weather at the time of ripening is not dangerous to cotton; the subsequent fine weather will set matters right.
14. Each grower should carefully observe the plants when growing, determine the kind best suited to his locality, and in future plantings keep to that kind.
15. If troubled with the boll-worm, mix 1 lb. Paris green with 50 lb. lime, and dust the plants through netting or hessian. When the boll-worm moth is likely to be numerous, plant trap crops as above described.

VALUE OF THE BY-PRODUCTS OF COTTON.

The undecorticated seed is worth from £4 to £6 per ton, whilst decorticated seed is worth from £7 to £8 per ton. The hulls and remaining lint, of which a ton of seed will give about 100 lb., are worth as paper material from £4 to £8 per ton. The refined oil sells at 3s. 4d. per quart in sealed cans. Furthermore, the cotton seed being crushed produces 37 gallons of oil per ton, and cotton-seed oil is worth from £23 to £24 per ton. Again, after the extraction of the oil, we have the oil-cake for cattle food. Oil-cake is worth up to £7 per ton. It will thus be apparent that the by-products of cotton are worth more than the actual lint.

WHAT CAN BE DONE WITH BANANA FIBRE?

In the November (1905) issue of "Tropical Life" we reproduced an article which our editor had written for another journal on the possibility of utilising the fibre in banana stems either for rope or paper making and other purposes. The final summing-up was as follows:—"Five hundred thousand tons of banana stems, calculated to yield 1·80 per cent. of fibre,* is equal to 9,000 tons of fibre, which, taken at only £20 a ton, would give £180,000 in London. Judging by the quotations given below, £20 per ton seems a low valuation.

The great drawback at that time was having to transport 500,000 tons of stems to some central factory, in order to obtain 9,000 tons of fibre. In the January issue of the "Queensland Agricultural Journal," an illustrated description is given of a machine invented and patented by a Tonquin agriculturist, which, if able to do the work claimed for it, could be carried round the banana fields to treat the leaves on the spot. The installation, we are told, consists of three extractors, one slicer, and one pulper, the whole costing about £5 [£10.—Ed. "Q.A.J.,"] and weighing under 25 lb., and is certainly worthy of attention until something better comes along.

Each machine, it is claimed, will turn out about 65 lb. of clean fibre in a day. When speaking of each machine, it would be more correct to describe it as five machines, each of the extractors being worked by a man, whilst a woman and a junior (boy or girl) can work, one the slicer and the other the pulper, the five turning out, as already stated, about 65 lb. of fibre a day between them. The labour bill would, of course, be the chief expense, but the raw material will cost nothing (perhaps even save money in causing a nuisance to be removed). In centres where labour is cheap, the cost of extraction should not be prohibitively high, so, whilst the fibre produced should sell for from £20 per ton upwards, according to the quality, a very good profit should accrue to planters in many banana-producing centres.

In a recent issue of the "Bulletin of the Imperial Institute," the director gives very full particulars of seven samples of banana fibres received from British East Africa in 1905, for chemical examination and commercial valuation, the reports on which, as to value, are as follow:—

Sample 1.—Probably from *Musa Livingstoniana*, a fairly lustrous, light-brown fibre, well cleaned and prepared, and of good strength. Fibre mostly 3 feet 5 inches to 4 feet 3 inches, but some shorter, say 2 to 3 feet, valued (in 1905) at £31 to £32 per ton in London. The fibre contained 74·4 per cent. of cellulose.

Sample 2 resembled the preceding in appearance, but rather more lustrous; length, 4 to 5 feet; very strong, soft, very fine, clean, fairly good colour and length; worth from £40 to £42 per ton. The fibre contained 75 per cent. of cellulose. The above were based on the price of Manila at £43 to £57 per ton.

Sample 3.—From 1 foot 9 inches to 3 feet 8 inches long, described as being short, soft, dull-yellowish in colour, and mixed length. Value about £20 to £22 per ton. The fibre contained 71·8 per cent. of cellulose.

Sample A.—Uneven length, 4 to 6 feet. Of a yellowish colour and satisfactory length; rather harsh. The fibre of two lengths—first worth £26, the other £30, per ton. The fibre contained 77·8 per cent. of cellulose.

Sample B.—Of the wild, claret-coloured banana; 5 to 6 feet long; fair colour, good strength, and satisfactory length. (Some parts were stained and weak, and care should be taken that the juice of the plant does not stain the fibre.) Value, £34 to £35 per ton. The fibre contained 71·5 per cent. of cellulose.

* Sir Daniel Morris, in his Cantor Lecture on "Commercial Fibres," at Society of Arts in 1905.

Sample C.—A wild banana, green variety. Tree about three-quarters grown. Fibre 6 to 8 feet long; described as being of excellent quality, well prepared, strong, lustrous, and worth £48 to £50 per ton. The fibre contained 73·4 per cent. of cellulose.

Sample D.—Wild banana, claret variety. Plant about half-grown. Fibre 5 to 6 feet long, carefully prepared, good length, colour, and strength. Value £45 to £46 per ton.

In the opinion of the commercial experts, the samples are comparable with the best fibres used for rope-making; and similar to the most expensive grades of Manila hemp (*M. textilis*), so should meet with a ready sale in London. When exporting such materials, the fibre should be roughly sorted as to length, so that the long may not be lessened by the presence of the shorter, as with sample 1. Two samples of fibre from German East Africa of *M. ensete* showed 78·1 and 74·5 of cellulose on analysis.

In looking at above valuations, planters must, of course, realise that none of these are the usual bananas of commerce—*i.e.*, *M. sapientum* or *M. cavendishii*; all the same, we strongly recommend every grower of bananas to extract the fibre, to at least send over a sample for report and valuation.

We take the above from "Tropical Life," and would ask our banana-growing readers to consider seriously the loss they annually sustain by allowing the banana stems which have borne fruit to rot on the ground whilst they contain a large quantity of valuable fibre. In the Cairns district the wild banana should afford lucrative employment to many people by the use of the fibre-extracting machine for which Mr. A. Robinson, Civil Service Stores, is agent. Several of these machines have, we are informed, already been purchased for New Guinea and the Solomon Islands.

THE PRIETO SISAL-CLEANING MACHINE.

As the time is approaching when larger machinery than is at present in use in Queensland and New Guinea will be required on the older plantations, it is well that planters should have the merits and demerits of the several machines on the market put clearly before them. In the pamphlet on the sisal industry in Queensland, issued in 1906, eight kinds of machines were mentioned as being in use in Yucatan, Hawaii, the Bahamas, and the Mauritius. Amongst these, mention was made of the Prieto machine, the invention of Mr. Manuel Prieto, of New York, but the writer was unable to give any description of it at the time. The requisite information is now furnished us by the Prieto Machine Company (Inc.), 45 Broadway, New York, to whom Mr. Prieto transferred his interests in December, 1905. The machines vary in capacity, power, method of extracting the fibre, engine-power required, and cost. They include the Ideal, double and single drum, the largest being the "Ideal" No. 1, having a capacity of 150,000 leaves per day; the "Irene," single drum, equal to dealing with 30,000 leaves per day; the "Irene," double drum, which can treat 120,000 leaves daily; the "Estrella," a machine for taking the fibre from all kinds of textile plants, with which from 80,000 to 100,000 leaves can be cleaned daily, and various others.

It will be sufficient in this short notice to consider the "Irene" and the "Ideal," the latest improved machines.

In these, the scraping wheels are heavy, thus ensuring an even run, and overcoming with ease the shocks which extra thick or unevenly-fed leaves give them. In the "Irene" No. 21 the leaves pass from one disc to the other by a special attachment, and run through the machine without the operator having to look after them. All he has to do is to feed the leaves into the machine, and a couple of boys suffice to take away the fibre as it comes from the other side of the machine.

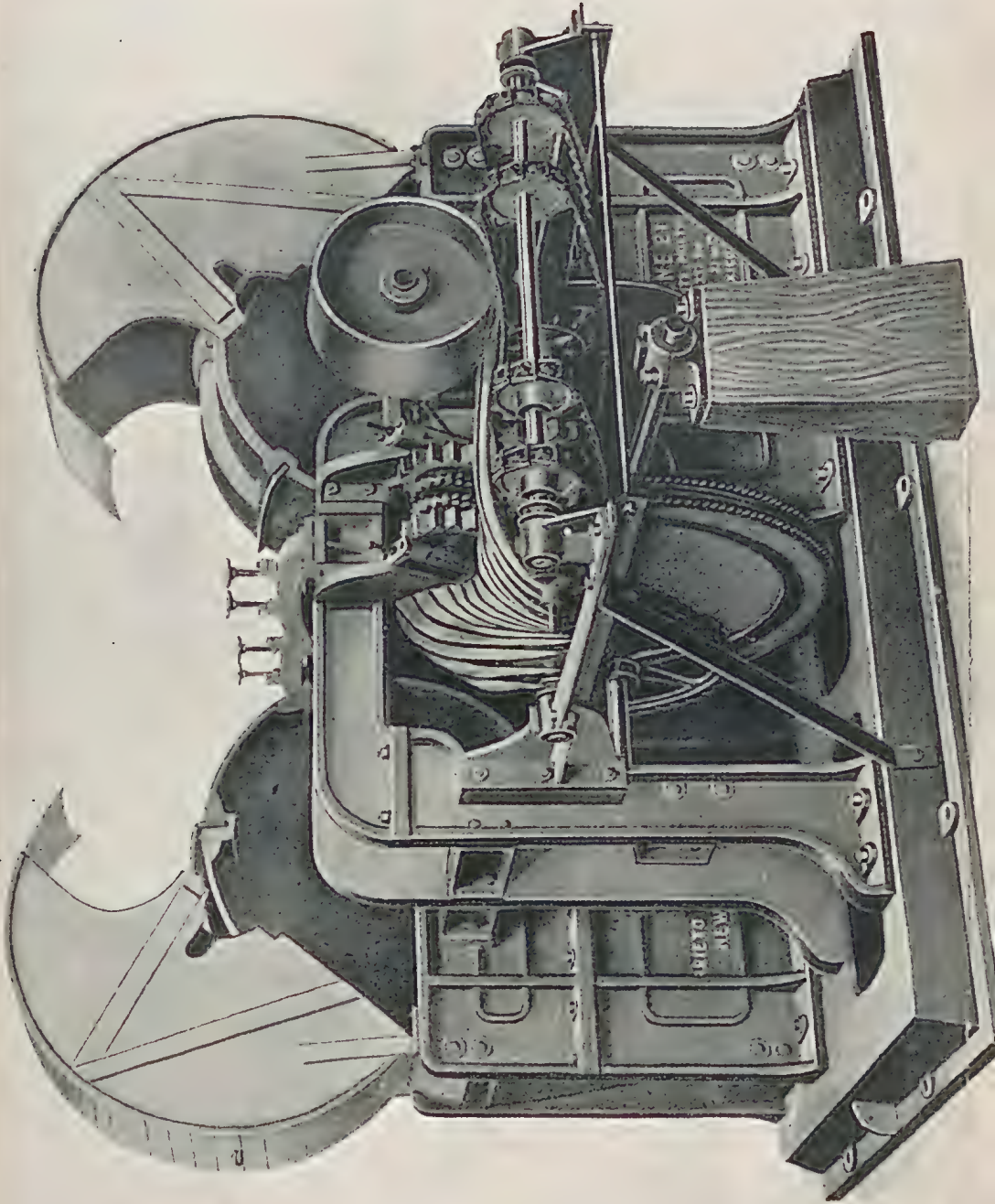

PRIETO FIBRE-CLEANING MACHINE—IRENE No. 21.

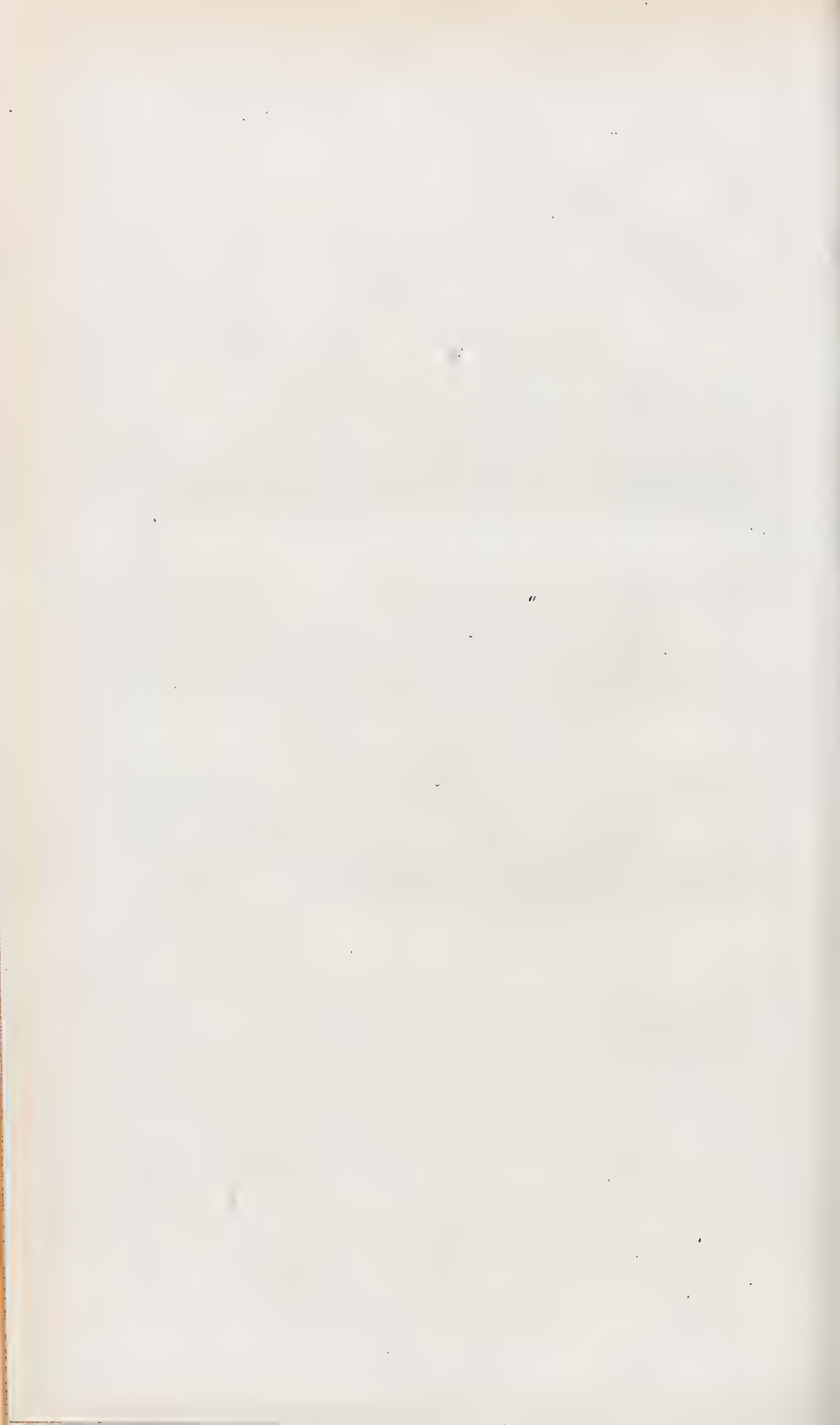

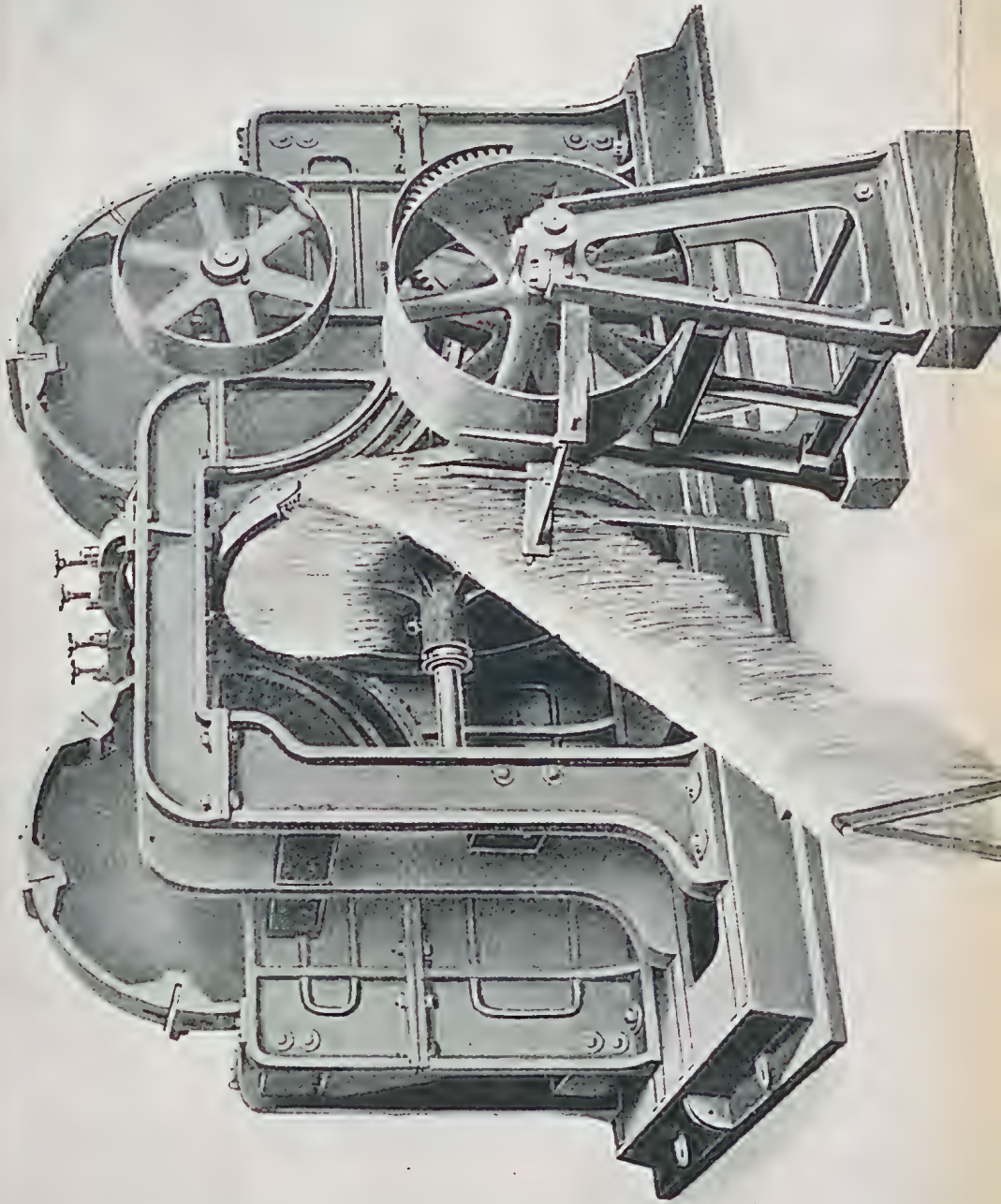

PRIETO FIBRE-CLEANING MACHINE—IRENE No. 21.

Plate VII.

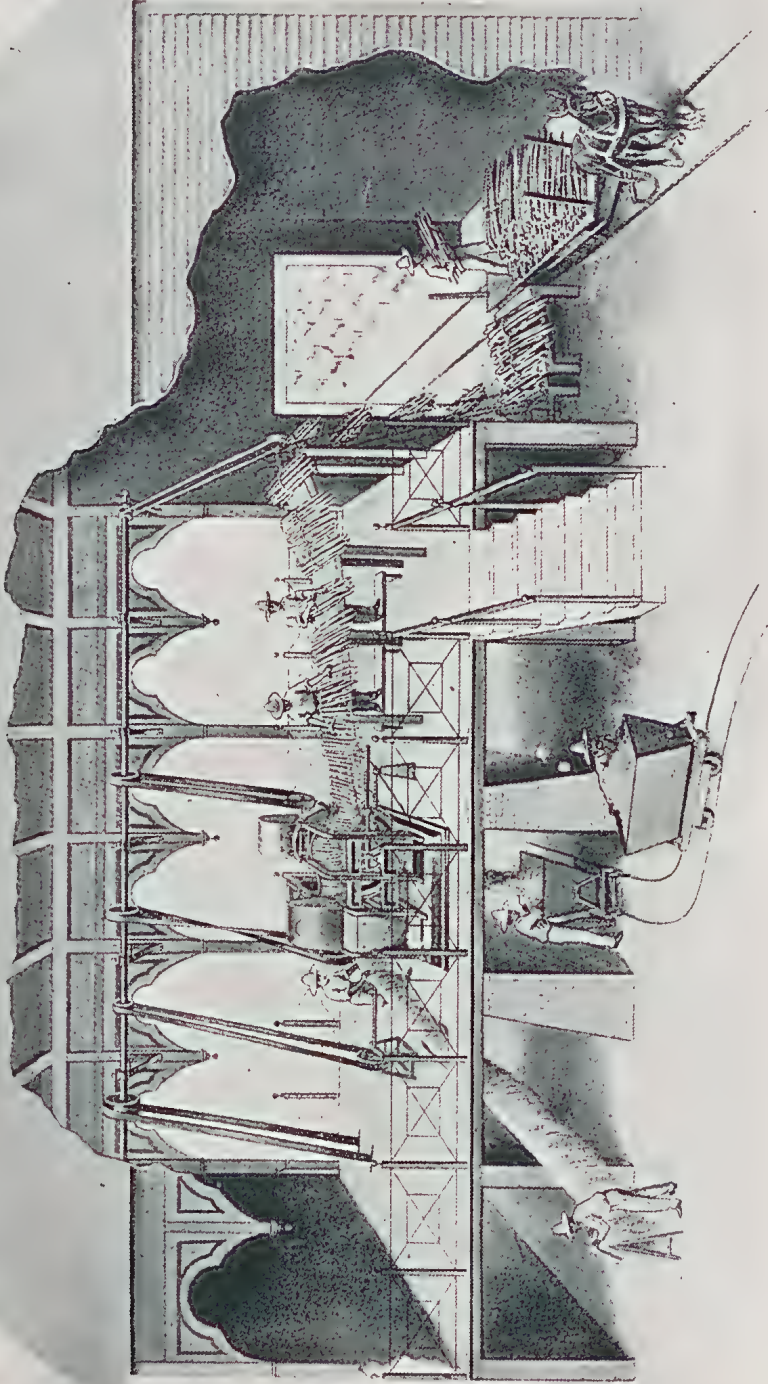

INSTALLATION OF FIBRE-CLEANING MACHINERY, SHOWING THE IRENE 21 AT WORK.



CUTTING AND TRIMMING LEAVES OF THE SISAL PLANT, YUCATAN

The illustration on another page shows a plant operating in Yucatan, Mexico, where 125,000 to 150,000 leaves are cleaned per day of 10 hours. It is to be recommended that a man should be stationed at the car into which the bagasse is dropped, so that he can watch the work of the machine, and give alarm in case excessive quantity of fibre is discharged with bagasse. The disarrangement of knives, lack of power, or any other accident which cannot be prevented, will immediately be detected by presence of excessive fibre in bagasse.

The leaves can be carried, in the most convenient manner to machine, and be deposited in bundles of 50 leaves on table. The elevator arms will take bundle to top, and drop it on a rather steep incline, where the strings which hold bundle are removed, and the leaves drop on the less inclined table, where they are spread and pushed along until the feed chains which pass leaves into the machine are reached. The machine passes leaves automatically from one disc to the other, and the clean fibre is delivered at the rear end. A piece of wood, similar to the rail of a stairway, is placed near the rear disc, and a boy attends to transferring fibre from the disc to the rail. As this rail is sharply inclined, the fibre slides down to lower floor, where it is received by the men, who take it to the drying-racks.

The prices of the several machines are quoted as follow:—

| | \$ | £ |
|---------------------|----------|-------|
| Estrella | 2,200'00 | = 440 |
| Irene No. 31 | 1,650'00 | = 330 |
| Irene No. 21 | 2,750'00 | = 550 |
| Ideal No. 1 | 3,800'00 | = 760 |
| Ideal No. 2 | 2,750'00 | = 550 |
| Ideal No. 12 | 3,800'00 | = 760 |
| Irene No. 44 | 1,250'00 | = 250 |

Cost of Belts, Pulleys, Shafts, &c., necessary to set up an installation:—

| | Irene 31. | | Irene 21. | | Ideal 1. | | |
|----------------------------|-----------|------|-----------|------|----------|------|--|
| | \$ | £ | \$ | £ | \$ | £ | |
| Bandas | 195'00 | = 39 | 220'00 | = 44 | 250'00 | = 50 | Belts
Pulleys, Shaft,
Hangers, &c.
Elevator |
| Poléas, Eje, Estantes, &c. | 405'00 | = 81 | 420'00 | = 82 | 455'00 | = 91 | |
| Elevador | 125'00 | = 25 | 125'00 | = 25 | 125'00 | = 25 | |

We assume that the prices quoted are American currency, the dollar being equal to 4s. 2d. We have given the prices in round numbers, taking 5 dollars to the £1 sterling. The Mexican dollar is worth from 2s. 1d. to 2s. 2½d. It would be a great advantage to enquirers if prices were also given in British currency.

THE "SANSIVIERIA" REGION OF UGANDA.

The "Exporters and Importers' Journal," New York, for 22nd February, gives a very graphic account of the Litoral of Equatorial East Africa. That portion of the narrative which deals with the fibre belt is of great interest to planters of Sansivieria in Queensland and Papua. This belt extends from Mukindu to below Voi, at an elevation of 3,500 to 2,000 feet, where, under semi-arid conditions, this indigenous fibre plant covers an area of 5,000 square miles in British East Africa alone, and the same fibre belt stretches right across German East Africa down to the Zambesi. In this belt the average rainfall is 25 inches, yet so dense is the growth of this primeval fibre, that huge pachydermatous wild beasts have difficulty in getting through what are called the "Fibre Islands."

Of course, the lack of water, and inaccessibility for the present, make a great deal of this area of no commercial value for the time being, but ample developments going on now will bring the whole into line in due course.

The Sansivierias, like the "Agaves" of the New World, belong to the great family of Liliaceæ. There are many different species, but only five or six are pre-eminently of commercial value, like *S. cylindrica*, *S. sulcata*, *S. ehrenbergii*, *S. volhensi*, and *S. kirki*.*

Sansivieria belongs commercially to the hard fibres, like Manila, sisal, and jaumauve. It is of a pale cream colour, very pliable, and has been proved, by exhaustive tests, to equal, and even to exceed in tensile strength, the famous Manila fibre as cordage. It also withstands the action of sea-water much better than sisal or hemp. Tests made with it by Admiral Fremantle, of the British slave-cruising squadron on the East Coast, proved it to be the most excellent material for deep-sea sounding lines, and the native fishermen will have no other for their tackle. Sir John Kirk, one of the most noted British administrators there, saw the enormous quantities growing wild in the interior during his extensive travels, and strenuously advocated the commercial exploitation of this promising material at a time when the Philippine hemp supply was ever at hazard by continuous native insurrections under Spanish rule.

Machinery to decorticate the leaves of Sansivieria has been the main factor in retarding the development of this particular industry, and it was not until a set of machines, made by the Finigan-Zabriskie Company, of Paterson, New Jersey, U.S.A., was invented, that the difficulty was finally overcome.

On the coast lands the sisal plant does well on the coral outcrops, but better still on the semi-arid "laterite" lands, 100 miles inland, and 2,000 feet above sea-level. There the sisal matures its suckers inside of three years, and the leaves attain an average length of 5 feet and over. At the time when Yucatan sisal fetched 7 cents per lb. (3½d.), the East African fibre sold at 10½ cents (5½d.).

Unlike the sisal, the Sansivierias favour shady localities, under trees and scrub. Their reproductive properties are truly marvellous. Any old piece of root or stalk will throw out roots, and grow into a new plant. One may take a piece of stalk, stick it into the ground, and let it take root, and tear it up and plant it again, and repeat the process several times, and it will still come up smiling, and all this without having been watered or tended. Neither locusts nor cattle nor pigs will touch the stalks.

NEGLECTED INDUSTRIES.

CASSAVA.

Nine staple field crops are produced in Queensland. These are sugar, cereals (wheat, barley, oats, maize, &c.), potatoes, onions, and lucerne. There are several minor crops produced, but we take the above as those most generally grown by farmers throughout the State. Amongst the neglected crops may be reckoned cotton, coffee, rice, cassava, rubber, sisal hemp, coconuts, castor oil, and a few others, for which the soil and climate are admirably adapted, and which offer a prospect of good returns. It may be conceded that cotton, sisal hemp, and rubber are at last engaging the serious attention of farmers, but it will be some years before the two latter products will become largely exported, except in two or three cases where the plantations of sisal are somewhat extensive.

* No mention is made here of *S. Zeylanica* or *S. Guineensis*, both of which yield a readily marketable fibre, which has been produced in Queensland, and valued in the United Kingdom and Germany at from £35 to £40 per ton.—Ed. "Q. A. J."

Plate IX.



WASHING SANSEVIERIA

DRYING THE FIBRE

THE SANSEVIERIA INDUSTRY IN UGANDA.

In this article we will consider the prospects of Cassava. This is the Manihot, or Manioc, so largely cultivated in the Brazils and in the West Indies as a food-product for man and beast. The plant, which much resembles the castor oil plant, is of two kinds, the sweet and the bitter (referring to the tubers). The tubers of the bitter Cassava are exceedingly poisonous, but the poison is entirely confined to the juice. When this is expressed, the pulp is perfectly harmless. Furthermore, the poison is so volatile that the tubers, when sliced and exposed to the hot sun, may be fed to cattle without any ill effects. Singular to say, the juice may be boiled with meat, and eaten without danger. In Brazil and in the West Indies a kind of soup is made with it, called "Cassareep," and Cassareep is the foundation of the celebrated West Indian "Pepper-pot," a recipe for which delicacy appeared in the last number (May) of this Journal.

The tuber of the Sweet Cassava is harmless, although it, also, contains a trace of poison, but the writer has often taken a small tuber from the ground and eaten it raw, as one might eat a carrot, turnip, or sweet potato.

There is no more difficulty in cultivating Cassava than in growing maize or sweet potatoes, and it is infinitely less troublesome to produce than sugarcane, coffee, or cotton. It is enormously productive, one acre of Cassava being equal in food value to 6 acres of wheat.

Writing on this subject, the "Indian Trade Journal" says:—

The results of the tests of twenty-one natives varieties of Cassava at the Hope Experiment Station, Jamaica, indicate that under the conditions of a moderate rainfall and a friable soil, very large yields of tubers are obtainable. At twelve months a maximum yield of $10\frac{1}{2}$ tons, rising to $15\frac{1}{2}$ tons at fifteen months, and of nearly 22 tons of tubers per acre at twenty-one months, has been recorded.

The indicated yield of starch per acre rose from $3\frac{1}{2}$ tons at twelve months to $5\frac{1}{2}$ tons at fifteen months, and over 7 tons of starch per acre at twenty-one months' growth in these trials. As a starch producer the Cassava should therefore take the highest place among the economic plants of the world.

MATURATION AND VARIETIES.

Of the twenty-one local varieties of Cassava tested in the experiments, two or three stood out as particularly prolific. Experience of Cassava varieties grown in Jamaica points very strongly to the necessity of planters testing all the best kinds themselves, as the greatest variations appear to exist in the behaviour of the same variety of Cassava under different conditions of soil and climate.

It is necessary to secure perfect drainage in the soil zone in which the tubers are produced, and to avoid the serious mistake of planting Cassava on stiff soil on the flat, without any drainage at all. Serious losses of tubers have already occurred on some large cultivations through the neglect of this first principle of Cassava cultivation. At Hope, the best variety for harvesting at twelve months' growth was found in the local Cassava grown in the district, and known as "White top." This gave $10\frac{1}{2}$ tons of tubers, containing nearly 4 tons of starch, per acre.

It would appear that in Jamaica a long period of growth is the most economical basis for Cassava cultivation, and that quick returns and early maturing varieties do not afford such a prospect of profit as the larger yields of varieties of longer growth. The variety "long leaf blue bud" was found superior to the "white top" when allowed to grow for fifteen months, yielding 15 tons of tubers, containing 5 tons of starch, per acre, while at twenty-one months' growth the lead was taken by "blue top," which gave the enormous return of 21.9 tons of tubers, containing over 7 tons of starch, per acre.

COST OF PRODUCTION OF TUBERS.

The cost of growing Cassava on a large scale in Jamaica has been studied by Messrs. J. W. Middleton, Joseph Shore, the Hon. H. Cork, the Hon. J. V. Calder, and at the Hope Experiment Station. It has been deduced from the figures put forward that Cassava should cost, for cultivation only, from £3 13s. to £5 per acre, according to locality and circumstances. The lower price represents the estimated cost under the most favourable conditions of broad-scale implemental culture on friable soils, while the higher price would be the cost of Cassava farming on rocky land by hand labour. An average cost of £4 per acre represents the estimated cost under favourable conditions of estate cultivation. The Hon. Henry Cork has estimated that a capital of £1,600 to £2,000 would be required for starting a cultivation of 100 acres of Cassava on new land. Allowing 10 per cent. on capital and 20 per cent. on live and dead stock account, Mr. Cork's estimate sets the actual cost of such a cultivation at £6 to £8 per acre. With regard to the yield of tubers to be expected, it would appear that an 8-ton crop should be a fair average, while good lands with efficient tillage should return 10 tons and more per acre. These figures indicate that Cassava can be grown in Jamaica at less than £1 per ton.

" MANUFACTURE.

Much has still to be worked out as to the most efficient plan for dealing with the Cassava grown in Jamaica, for the manufacture of starch, cassareep, and cattle food. The first process is that of washing and decorticating the tubers. For this purpose the simple machine recently devised by the Hon. T. H. Sharp appears to be entirely satisfactory. The great cost of peeling tubers by hand in the early experiments is thus entirely avoided, and the tubers are automatically washed and delivered free of the cortex by the operations of this machine. This invention has solved one of the outstanding difficulties that faced the starch producer in Jamaica. To secure an efficient recovery of starch, the finest possible disintegration of the cut tissues of the Cassava is necessary. There are mills now obtainable that give excellent results, and produce a very fine disintegration at a high rate of production. A second grinding or disintegration should be carried out where starch is the main object of manufacture, but where a good market can be found for the dried residue as a cattle food, the second milling may probably be disregarded. The sieving, purification, settling, refining, and drying of the starch seem all to be capable of easy accomplishment with suitable machinery, and there is now no doubt at all that a starch factory, to produce 1,000 tons of starch a year, could be erected with every certainty of producing a high grade of Cassava starch. Such a factory should not cost more than £6,000 or £7,000 to erect, and, with intelligent management, a satisfactory result should be assured.

COMMERCIAL VALUE OF CASSAVA STARCH.

It would appear that a well-made Cassava starch is worth £14 to £16 per ton in the English market. At such prices as these there is a liberal margin of profit. The "bitty," when dried, is a valuable cattle food. A sample from the Longville factory was found to contain 65.7 per cent. of carbo-hydrates, on basis of 15 per cent. of moisture, and should find a ready sale at £2 10s. to £3 per ton. A planter from Dominica recently stated that he had found a good market for cassareep in England, and it is possible that this article may become a useful by-product in the manufacture of Cassava starch.

Although Cassava has been grown in Jamaica from the earliest days of which any record is obtainable, it is only recently that its commanding merits, as a source of high-class starch, have attracted the attention of practical men.

It is now admitted that Cassava starch has certain qualities that make it of exceptional utility in the dressing of cotton goods, and there is also reason to believe that the quality of the Cassava starch produced in Jamaica is superior to that obtained from the same plant grown in the East Indies.

CULTIVATION.

Now, a few words about the planting and cultivation of Cassava in Queensland. The best land for its successful cultivation is a loose, dry, well-drained sandy loam of considerable depth. Heavy land, with a clay subsoil, are to be avoided. When the land has been properly prepared, make cuttings of the stem of the plant about 6 to 8 inches long from the mature wood, and lay them horizontally in the furrow, as in the case of sugar-cane. In a fortnight from planting they will begin to shoot. Keep the ground clean until the plants are high enough to cover the ground, and in eight months after planting the tubers will be ready to dig.

There is no need to dig the whole crop at once. The tubers may be left a whole year in the ground after they are ready for use, and will improve in that time rather than deteriorate.

The plant thrives best near the sea, or inland within the influence of the sea-breeze. It does not require much moisture, except in the early stage of its growth, as too much humidity causes the roots to decay and perish.

Statistics.

COMMONWEALTH METEOROLOGY.
RAINFALL OF QUEENSLAND.

TABLE SHOWING THE TOTAL RAINFALL FOR EACH MONTH OF THE YEAR IN THE AGRICULTURAL DISTRICTS OF QUEENSLAND.

| STATIONS. | 1907. | | | | | | | | 1908. | | | | |
|-----------------------|-------|-------|-------|------|-------|------|------|-------|-------|-------|-------|--------|-------|
| | May. | June. | July. | Aug. | Sept. | Oct. | Nov. | Dec. | Jan. | Feb. | Mar. | April. | May. |
| <i>North.</i> | | | | | | | | | | | | | |
| Bowen | 3.46 | 2.87 | Nil | 1.28 | 0.51 | 0.06 | 3.71 | 6.39 | 10.14 | 5.63 | 9.46 | 3.73 | 0.99 |
| Cairns | 8.65 | 4.45 | 0.12 | 0.39 | 1.35 | 0.63 | 5.35 | 28.33 | 27.02 | 8.03 | 20.60 | 5.99 | 3.05 |
| Geraldton | 21.91 | 8.54 | 2.39 | 4.68 | 1.36 | 1.42 | 6.45 | 33.82 | 44.39 | 13.27 | 39.00 | 14.23 | 18.52 |
| Herberton | 1.57 | 2.71 | Nil | 0.11 | 0.12 | 0.17 | 3.41 | 9.57 | 9.29 | 5.02 | 8.92 | 1.40 | 0.38 |
| Hughenden | 1.34 | 0.95 | 1.16 | Nil | Nil | 1.66 | 0.68 | 7.75 | 0.98 | 5.18 | 6.91 | 0.30 | .. |
| Kamerunga State Nurs. | 9.33 | 5.29 | 0.13 | 1.15 | 1.19 | 0.53 | 2.76 | 29.32 | .. | 7.47 | 25.75 | 4.60 | 3.363 |
| Mackay | 6.09 | 5.04 | 0.27 | 0.25 | 0.12 | 0.12 | 5.76 | 9.70 | 9.28 | 3.83 | 17.43 | 14.82 | 3.25 |
| Rockhampton | 0.94 | 4.16 | 0.84 | 0.47 | Nil | 0.47 | 3.72 | 4.42 | 3.84 | 9.64 | 9.77 | 2.62 | 0.85 |
| Townsville | 3.11 | 2.38 | Nil | 0.07 | 0.14 | 0.03 | 2.82 | 24.26 | 12.21 | 6.69 | 9.03 | 0.33 | 2.22 |
| <i>South.</i> | | | | | | | | | | | | | |
| Biggenden State Farm | 4.02 | 5.24 | 1.51 | 0.96 | 0.24 | 1.99 | 2.50 | 5.55 | 2.37 | 9.82 | 9.84 | 2.97 | 0.74 |
| Brisbane | 4.75 | 2.91 | 0.39 | 0.79 | 0.10 | 1.37 | 4.25 | 3.21 | 2.80 | 8.43 | 18.19 | 2.45 | 2.10 |
| Bundaberg | 3.08 | 4.49 | 0.87 | 0.43 | Nil | 1.70 | 2.90 | 2.99 | 4.77 | 2.82 | 7.35 | 4.13 | 0.67 |
| Dalby | 2.26 | 2.35 | 0.87 | 0.71 | 0.15 | 0.69 | 5.18 | 1.44 | 0.17 | 4.88 | 7.61 | 0.11 | 0.37 |
| Eak | 5.42 | 2.66 | 0.54 | 0.81 | 0.57 | 0.50 | 3.76 | 3.72 | 2.61 | 10.06 | 17.04 | 2.83 | 1.07 |
| Gatton Agric. College | 2.80 | 1.85 | 0.54 | 0.56 | 0.15 | 0.71 | 3.01 | 4.55 | .. | 3.38 | 10.74 | .. | 0.10 |
| Gindie State Farm ... | Nil | 2.29 | 1.58 | 0.10 | 0.16 | 0.61 | 1.57 | 4.42 | 0.20 | 7.17 | 6.25 | 0.02 | 0.112 |
| Gympie | 3.84 | 3.77 | 0.80 | 0.17 | 0.47 | 1.20 | 3.05 | 5.49 | 6.26 | 11.77 | 89.8 | 1.87 | 2.00 |
| Ipawich | 3.43 | 2.22 | 0.30 | 0.43 | 0.05 | 0.78 | 4.45 | 3.40 | 1.32 | 6.63 | 13.77 | 2.71 | 1.14 |
| Maryborough | 3.21 | 6.05 | 0.64 | 0.93 | 0.25 | 2.74 | 3.49 | 5.81 | 5.62 | 8.07 | 11.40 | 2.52 | 1.05 |
| Roma | 0.27 | 2.47 | 1.03 | 0.42 | 0.04 | 1.04 | 3.70 | 2.51 | 0.04 | 6.38 | 2.51 | 0.22 | .. |
| Tewantin | 7.16 | 7.61 | 1.48 | 0.95 | 0.55 | 1.05 | 3.12 | 7.38 | 10.42 | 12.47 | 14.39 | 7.59 | 8.66 |
| Warwick | 1.58 | 1.27 | 1.16 | 1.37 | 0.01 | 1.37 | 3.25 | 3.13 | 0.76 | 4.52 | 6.65 | 1.40 | 0.15 |
| Westbrook State Farm | 2.53 | 2.53 | 1.04 | 1.78 | Nil | 1.08 | 4.76 | 3.23 | 0.43 | 8.03 | 1.41 | 1.40 | 0.05 |
| Yandina | 4.83 | 6.98 | 1.15 | 0.68 | 0.89 | 1.44 | 2.87 | 3.05 | .. | .. | 16.62 | 5.45 | 4.59 |

Note.—The rainfall data in this table are compiled from telegraphic reports, and must be considered approximate only.

GEORGE G. BOND,
Divisional Officer.

Science.

ELECTROLYSIS IN REINFORCED CONCRETE.

The apparent advantages of reinforced concrete for building silos over timber or iron have been so amply demonstrated that it is probable many of these useful structures will be constructed of this material. One of the strongest recommendations for its use as a protective envelope for steel or iron structures is the fact, or we should say, the belief, that concrete effectually prevents the corrosion of the imbedded material. Recently, however, a writer in "Art, Trade, and Industry," has raised, or rather revived, the question as to whether, under certain conditions, the steel of reinforced concrete may not be subject to the destructive effects of electrolysis. The revival of interest is due to some experiments recently made by Mr. A. A. Knudson, of New York, and reported a few weeks ago to the American Institute of Electrical Engineers. The experiments were carried out as follow:—Some blocks of 1 to 1 Portland cement sand concrete were moulded in a common metal water-pail, with a piece of 2-inch wrought-iron pipe placed vertically within the blocks to a depth of about 8 inches. When the blocks were three years old, one of them was placed in a tank of sea water, and another in a tank of fresh water, with direct current to feed to the iron pipes in the centre of each block, the negative electrode consisting of a piece of sheet iron placed in the tank. A third block, similar to the other two, was placed in a tank of sea water, but was not subjected to the electric current. After a period of thirty days the last-named block was found to be in perfect condition and the imbedded pipe was perfectly right. But the other two blocks, which had developed cracks during the test, were easily broken open; yellowish deposits were found in the cracks where the concrete had deteriorated to such a degree that it could be easily cut with a knife, and the pipes were considerably corroded, showing a loss of weight of over 2 per cent. Similar results were obtained in tests with blocks of standard Rosendale cement, made in the same mould, although in this case the blocks were tested thirty days after they had been made. The cracking of the concrete appeared as early as the sixth day of the test, and by the eighteenth day they looked as though they might fall apart. One of the pipes showed a corrosion similar to the pitting action of underground electrolysis, a hole $\frac{3}{8}$ by 1 inch being formed through the wall of the pipe.

It cannot be denied that these results are of profound significance. They call for careful investigation on the part of concrete engineers, and the provision of special means of insulation in all cases where imbedded structural steel, of the reinforcing material of armoured concrete, is liable to attack by stray currents in the neighbourhood of wet foundations. The whole subject of electrolysis which, because of the exaggerated use to which it has been put by a sensational Press, has not received from technical men the attention which it deserves, should be made the subject of a searching investigation, with a view to determining the laws and limits of this form of corrosion. The existence of a valuable building material is menaced, and the preventive is simple.

Commenting upon the above, Mr. A. Morry, surveyor, Department of Agriculture and Stock, who is a specialist in the construction of concrete silos, says that the conditions in all concrete structures are quite different to those in the blocks tested. Metal work in structures of this class is *never* brought in direct contact with the earth, and in the case of silos especially, no such electrolytic action could possibly result.

Animal Pathology.

REPORT ON METHODS ADOPTED FOR THE ERADICATION OF CATTLE TICKS IN THE UNITED STATES OF AMERICA.

By SYDNEY DODD, F.R.C.V.S.,

Principal Veterinary Surgeon and Bacteriologist to the Queensland Department of Agriculture and Stock.

No official reports covering a later period than the above are to be obtained, but, through the kindness of Dr. Kierhan, who has charge of the work in North Carolina and Virginia, I am able to give a summary of the work done in those States up to the end of 1907.

TICK ERADICATION.

| Area, Square Miles. | Total No. of Herds. | Total No. of Cattle. | No. of Herds Infested at First Inspection. | No. of Infested Cattle at First Inspection. | No. of Infested Herds, 1st September, 1907. | No. of Infested Cattle, 1st September, 1907. |
|------------------------|---------------------|----------------------|--|---|---|--|
| VIRGINIA. | | | | | | |
| 10,297 | 24,740 | 106,750 | 1,991 | 10,498 | 652 | 3,751 |
| NORTH CAROLINA. | | | | | | |
| 10,364 | 24,752 | 100,350 | 2,398 | 10,737 | 463 | 1,907 |

The cost of the work of eradicating the cattle tick varies a good deal in different States, but at present the actual figures are unobtainable. In North Carolina, in 1906, it cost about 15 dollars (£3) per day for each inspector, and the number of cattle treated (oiling, &c.) varied from 7 to 15 head daily. (In this State a good deal of the actual work of oiling the cattle is done by the inspectors instead of their merely acting as advisers.)

In Carolina, Georgia, and Virginia it is estimated to cost about 20 cents (10d.) per head of cattle for the preliminary inspection. Of the measures adopted by the United States Bureau of Animal Industry for eradicating ticks from cattle in the infested districts, the following are the chief:—Details are given in the various bulletins issued to farmers by the Bureau of Animal Industry: (1) Picking or brushing them off; (2) Smearing or spraying cattle with crude petroleum oil or an emulsion; (3) Dipping in a vat with crude oil or an emulsion.

1.—PICKING OR BRUSHING THE TICKS OFF CATTLE.

This method is applicable where the herd is small; the ticks being picked off the cattle by hand, or scraped off with a blunt knife or curry-comb. It is a laborious method, and needs to be done at least three times a week so as to find all the ticks before they mature and drop off. Of course, no fresh-infested cattle or equines are allowed to be brought on the premises, nor hay from infested pastures.

2.—SMEARING OR SPRAYING CATTLE WITH OIL.

It is asserted by the United States authorities that crude petroleum oil, or that known as Beaumont crude oil, is efficacious, not only freeing cattle from ticks, but that it will prevent ticks from getting on cattle for a short period. The cattle to be treated are covered entirely with the oil, which is either applied by hand by means of a brush or piece of cloth, or the animals are sprayed with an ordinary spray pump. In some parts an emulsion of the oil is used, made up with crude oil, soap, and soft water. In oiling cattle the greatest trouble experienced is to get the owner to apply the oil thoroughly, for, if it is to be of any use at all, no part of the animal must be left untouched.

3.—DIPPING IN A VAT.

Here, again, crude Beaumont oil is used. This method is adopted on the large ranches where the foregoing methods are not applicable. This oil is said to be superior to any other of the dips tried for destroying ticks. The light crude oils are said to be better than the heavy ones, as the latter injure the cattle when dipped in them. At first it was thought that an oil heavily charged with sulphur was essential, but I am informed that experiments appear to indicate that sulphur does not play such an important rôle in destroying the ticks as was thought.

The Bureau recommends an oil with 40 per cent. of its bulk having a boiling point between 200 degrees and 300 degrees C., with a specific gravity between $22\frac{1}{2}$ degrees and $24\frac{1}{2}$ degrees Beaumé, and containing $1\frac{1}{4}$ to $1\frac{1}{2}$ per cent. of sulphur. I have obtained analyses of three samples of Beaumont crude oil which were used for dipping cattle. All three are said to have been equally of use in destroying ticks, but one was found to injure the cattle, whilst the others were harmless.

The analyses are here given:—

Beaumont Oil, No. 1.

| | | |
|---|--------|--------------------------------------|
| Gravity Bé. | | 24 degrees. |
| Distillation of 100 c.c. | | |
| 150 degrees and below | | 1.65 per cent. |
| 150 degrees to 180 degrees | ... | 0.95 per cent. |
| 180 degrees to 210 degrees | ... | 7.75 per cent. |
| 210 degrees to 240 degrees | ... | 10.0 per cent. |
| 240 degrees to 270 degrees | ... | 13.0 per cent. |
| 270 degrees to 300 degrees | ... | 10.50 per cent. |
| | | 43.85 per cent. below 300 degrees C. |
| Flash point, 51 degrees C. or 122 degrees Fahr. | | |
| Sulphur, 1.25 per cent. | | |

Beaumont Oil, No. 2.

| | | |
|---|--------|--------------------------------------|
| Gravity Bé. | | 22 degrees. |
| Distillation, 50 c.c. | | |
| 150 degrees and below | | 2.50 per cent. |
| 150 degrees to 180 degrees | ... | 1.00 per cent. |
| 180 degrees to 210 degrees | ... | 7.00 per cent. |
| 210 degrees to 240 degrees | ... | 10.80 per cent. |
| 240 degrees to 270 degrees | ... | 13.00 per cent. |
| 270 degrees to 300 degrees | ... | 10.40 per cent. |
| | | 44.70 per cent. below 300 degrees C. |
| Flash point, 60.6 degrees C. or 140 Fahr. | | |
| Sulphur, 1.51 per cent. | | |

Beaumont Oil, No. 3.

| | | |
|------------------------------------|--------|---|
| Oil which Injured Cattle. | | |
| Gravity Bé. | | 21.5 degrees. |
| Oils Distilling below 300 Degrees. | | |
| 215 degrees to 240 degrees | | 10.0 per cent. |
| 240 degrees to 270 degrees | | 17.8 per cent. |
| 270 degrees to 300 degrees | | 12.8 per cent. |
| | | 40.6 per cent. between 215 degrees and 300 degrees. |
| Moisture | | 14 |
| Sulphur | | 0.58 |

Other oils from wells in different parts of America are used in various parts, but not, as far as I can gather, with such success as the Beaumont oil.

The conditions under which the oil should be applied to animals, in order that a minimum amount of risk may be run, are:—

- (1) The animals should be rested for at least five days after treatment.
- (2) They should be provided with shelter from the sun.
- (3) They should have access to plenty of good drinking water.
- (4) Extreme heat or cold should be avoided.
- (5) Wet weather will result in a lot of the oil being washed off, and hence its full effect will not be seen.

If these precautions are not observed, fatalities may occur, and even sometimes under favourable conditions burning of the skin takes place, at times very severely.

Another plan for freeing cattle from ticks, known as the "Soiling" method, was first suggested by Curtice, and is based upon a knowledge of the life history of the cattle tick. The time elapsing between the dropping of the mature female tick and the hatching of its eggs is rarely less than three weeks, and the time spent by the tick upon an animal from the period of its attaching itself to the time of the dropping off is usually from twenty to forty-five days. When the tick-infested cattle are to be cleaned, as is necessary before they are put on uninfested pastures, it is recommended that the cattle be kept in a tick-free paddock for three weeks, when many of the ticks will have fallen off. They should then be moved into a similar paddock for another three weeks, and, if necessary, into a third enclosure to make quite sure that all ticks have dropped off, when they can be put on to the clean pasture. It will be observed that the cattle do not stay long enough in any one paddock to allow of fresh ticks hatching and reinfesting animals. Of course, these pens cannot be used repeatedly until they have been rendered free from ticks, and any hay fed to the animals must be from tick-free pastures.

Methods Adopted for Freeing Pastures from Ticks.

These, again, are based upon a knowledge of the life history of the tick.

One method is to exclude all cattle, horses, mules, and donkeys from the pasture for a definite period, and so starve out the tick. This may be accomplished by simply dividing the ground into two parts by a double fence. One part is kept free from cattle or equines for a certain period, then the cattle are cleaned from ticks by one of the foregoing methods, and turned into the vacant part, which is now tick free. The other part is cleaned in the same way.

Another way for destroying ticks on pastures is to cultivate the soil for a year without permitting any ticky cattle, horses, or mules on the ground.

A third method, recommended by the department for pastures that are too large to be cleaned in the above ways, is to burn off the grass in the spring or autumn, and then keeping tick-infested animals off the land. This method, although useful as an aid in cleaning the ground, is unreliable in itself, as one may come across patches of grass or bare ground which have escaped the fire, and any ticks which may be on these patches will escape.

The "Feed lot" method. The plan here is to take a field, which has been sown with corn, millet, or any other forage, and fence off from it three parts. (This plan is recommended for the purpose of freeing cattle and pastures at the same time.) As in the "Soiling" method, the cattle are moved every three weeks. The cattle after passing through the three parts are then tick free, and are put into the remaining part of the field. In the next year, the cattle may be turned into the regular pastures which have remained vacant, and have also become tick free.

The remaining method is that of pasture rotation. Here, again, the field is divided into two parts by a double fence 10 feet apart, to prevent the ticks migrating from one field to another. Cattle are removed from one part to the

other, and the first remains vacant for a certain time. The cattle are then moved at intervals of three weeks to three different tick-free, cultivated fields. When the ticks have died out of the original pasture, the cattle which are now clean are put back again.

As the main object at present in the United States is to place the quarantine line further south, the plan adopted by the authorities in mapping out the sphere of operations for the season is to take the existing quarantine line as one boundary, and then fix a new boundary line running roughly in a circle, so as to enclose an area of tick-infested country. The size of this area depends upon—(1) The nature of the country; (2) the amount of money the department has to spend upon the work, which naturally determines the number of inspectors who can be employed; and (3) the number of herds and cattle in the enclosed area. Where possible, natural boundaries are preferred to artificial ones. As before mentioned, it is also ascertained whether the State concerned has efficient laws to prevent owners allowing their ticky cattle to stray on public lands or roads, and to enable infringements of the law to be punished.

After the area in which tick eradication is to be carried on is defined, it is placed in quarantine, notice defining the new boundaries being published in the local newspapers, and posted upon court houses and on all the roads leading into the newly-quarantined area. In fact, the utmost publicity is given to the regulations. By this order, all movement of cattle from tick-infested districts into or out of the proclaimed area is totally prohibited. This area, which is under the charge of a veterinary inspector, is then divided up into sections; each section is placed in charge of a subordinate veterinary inspector, and, under their supervision, stock inspectors make a farm-to-farm survey of the section. Their preliminary duty is to make a record of the number of farms infested and non-infested with ticks; the number and description of cattle on the farm, and also how many are tick infested, and how many are free; also a number of other details are observed. The system of dealing with infested and non-infested cattle or land appears to vary to some extent in various States, but the general rule appears to be that, if on inspection a farm is found tick infested, the farmer is served with a quarantine notice to the effect that his cattle are infested with ticks, and he is, therefore, forbidden to move or allow to be moved any cattle to or from his premises, and he is directed to free them from the tick by either of the methods recommended by the inspector.

During the survey the various methods for getting rid of the tick are explained to the farmer by the inspector, and he also suggests what method would be most suitable in that particular case. A record is kept of whatever method the cattle-owner decides to adopt. If the farmer is indifferent or refuses to take any steps in the matter, his premises are simply kept closed against any movement.

In some States, however, the law provides that where an owner refuses to carry out the process of disinfection it may be done by the local authorities, and the cost recovered from the owner by selling his cattle. Infractions of the law, whether deliberate or accidental, are punished.

In about twenty-one days after the first visit, not longer, a second inspector visits the various farms, to see whether the work is being carried out properly or at all. If not, the practice is now to try to persuade the farmer to start at once, and even to assist him by showing him how to proceed. Other visits are made every three weeks to see whether the cattle have picked up fresh ticks or whether the work is still being done. If nothing has been done, stronger pressure is applied at each visit.

The veterinary inspector in charge of the section is responsible for inspecting farms when the work is finished, and certifying whether they are free from ticks or not. If the inspector is satisfied, the quarantine area is declared free, the northern or old quarantine line is thrown open, and the southern boundary then becomes the northern one. As a result, the cattle in this newly-released

area have unrestricted access to the northern markets, with all the benefits which this entails. The next season a new area is enclosed, and the work goes on as before.

Records of work done are kept by the veterinary surgeon in charge of the district, and also by the chief office at Washington, so that it is always possible to note whether the work is being carried out properly, or whether any farm or herd has been missed.

The following is a statement of inspection work up to 31st October, 1906, taken from a report issued by the Bureau of Animal Industry in 1907:—

| State. | No. of Federal Veterinary Inspectors Employed. | INSPECTIONS. | | | | | Number of Counties. |
|---------------------|--|---------------|----------------|----------------|----------------|-----------|---------------------|
| | | Herds. | Cattle. | | | | |
| | | | Free. | Infested. | Total. | | |
| Alabama | 3 | 780 | 4 | 5,550 | 5,554 | 2 | |
| Arkansas | 3 | 1,527 | 6,671 | 2,328 | 9,003 | 2 | |
| California | 9 | 1,015 | 67,517 | 58,889 | 126,406 | 11 | |
| Georgia | 13 | 4,474 | 10,053 | 6,365 | 16,418 | 7 | |
| Kentucky | 7 | 4,077 | 13,653 | 7,332 | 20,985 | 4 | |
| Missouri | 3 | 126 | 3,000 | 1,430 | 4,450 | 3 | |
| N. Carolina | 7 | ... | 7,203 | 1,632 | 8,835 | 3 | |
| Oklahoma | 17 | 10,589 | 97,860 | 16,972 | 114,832 | 5 | |
| Tennessee | 14 | 6,317 | 23,204 | 15,840 | 39,044 | 17 | |
| Texas | 11 | 410 | 86,682 | 99,175 | 185,857 | 17 | |
| Virginia | 13 | ... | 12,217 | 5,263 | 17,480 | 11 | |
| Total | 101 | 29,315 | 328,064 | 220,780 | 548,844 | 82 | |

Times of Sunrise and Sunset at Brisbane, 1908.

| DATE. | MAY. | | JUNE. | | JULY. | | AUGUST. | | PHASES OF THE MOON. |
|-------|--------|-------|--------|-------|--------|-------|---------|-------|----------------------------------|
| | Rises. | Sets. | Rises. | Sets. | Rises. | Sets. | Rises. | Sets. | |
| 1 | 6:14 | 5:16 | 6:30 | 5:0 | 6:39 | 5:4 | 6:30 | 5:18 | 1 May ☉ New Moon 1 33 a.m. |
| 2 | 6:14 | 5:15 | 6:31 | 5:0 | 6:39 | 5:4 | 6:29 | 5:19 | 8 " ☾ First Quarter 9 23 p.m. |
| 3 | 6:15 | 5:15 | 6:31 | 5:0 | 6:39 | 5:4 | 6:29 | 5:19 | 16 " ☽ Full Moon 2 32 " |
| 4 | 6:15 | 5:14 | 6:32 | 5:0 | 6:39 | 5:5 | 6:28 | 5:20 | 23 " ☽ Last Quarter 10 17 a.m. |
| 5 | 6:16 | 5:13 | 6:32 | 5:0 | 6:39 | 5:5 | 6:28 | 5:20 | 30 " ☉ New Moon 1 14 p.m. |
| 6 | 6:16 | 5:12 | 6:33 | 5:0 | 6:39 | 5:6 | 6:27 | 5:21 | |
| 7 | 6:17 | 5:12 | 6:33 | 4:59 | 6:39 | 5:6 | 6:26 | 5:21 | |
| 8 | 6:17 | 5:11 | 6:33 | 4:59 | 6:39 | 5:6 | 6:25 | 5:22 | |
| 9 | 6:18 | 5:10 | 6:34 | 4:59 | 6:39 | 5:7 | 6:24 | 5:22 | 7 June ☾ First Quarter 2 56 p.m. |
| 10 | 6:18 | 5:10 | 6:34 | 4:59 | 6:39 | 5:7 | 6:24 | 5:23 | |
| 11 | 6:19 | 5:9 | 6:35 | 4:59 | 6:39 | 5:7 | 6:23 | 5:23 | 14 " ☽ Full Moon 11 55 " |
| 12 | 6:19 | 5:8 | 6:35 | 4:59 | 6:38 | 5:8 | 6:22 | 5:24 | |
| 13 | 6:20 | 5:8 | 6:36 | 4:59 | 6:38 | 5:8 | 6:21 | 5:24 | 21 " ☽ Last Quarter 3 26 " |
| 14 | 6:21 | 5:7 | 6:36 | 4:59 | 6:38 | 5:9 | 6:21 | 5:25 | |
| 15 | 6:21 | 5:7 | 6:36 | 4:59 | 6:38 | 5:9 | 6:20 | 5:25 | 29 " ☉ New Moon 2 31 a.m. |
| 16 | 6:22 | 5:6 | 6:37 | 5:0 | 6:37 | 5:10 | 6:19 | 5:26 | |
| 17 | 6:22 | 5:6 | 6:37 | 5:0 | 6:37 | 5:10 | 6:18 | 5:26 | 7 July ☾ First Quarter 6 25 a.m. |
| 18 | 6:23 | 5:5 | 6:37 | 5:0 | 6:37 | 5:11 | 6:17 | 5:27 | |
| 19 | 6:23 | 5:5 | 6:37 | 5:0 | 6:37 | 5:11 | 6:16 | 5:27 | 14 " ☽ Full Moon 7 48 " |
| 20 | 6:24 | 5:4 | 6:38 | 5:0 | 6:36 | 5:12 | 6:15 | 5:28 | 20 " ☽ Last Quarter 10 2 p.m. |
| 21 | 6:25 | 5:4 | 6:38 | 5:1 | 6:36 | 5:12 | 6:14 | 5:28 | |
| 22 | 6:25 | 5:3 | 6:38 | 5:1 | 6:35 | 5:13 | 6:13 | 5:29 | 28 " ☉ New Moon 5 17 " |
| 23 | 6:26 | 5:3 | 6:38 | 5:1 | 6:35 | 5:13 | 6:12 | 5:29 | |
| 24 | 6:26 | 5:2 | 6:39 | 5:1 | 6:34 | 5:14 | 6:11 | 5:30 | |
| 25 | 6:27 | 5:2 | 6:39 | 5:1 | 6:34 | 5:14 | 6:10 | 5:30 | 5 Aug. ☾ First Quarter 7 40 p.m. |
| 26 | 6:28 | 5:1 | 6:39 | 5:2 | 6:34 | 5:15 | 6:9 | 5:31 | |
| 27 | 6:28 | 5:1 | 6:39 | 5:2 | 6:33 | 5:15 | 6:8 | 5:31 | 12 " ☽ Full Moon 2 59 " |
| 28 | 6:29 | 5:1 | 6:39 | 5:3 | 6:32 | 5:16 | 6:7 | 5:31 | |
| 29 | 6:29 | 5:1 | 6:39 | 5:3 | 6:32 | 5:17 | 6:6 | 5:32 | 19 " ☽ Last Quarter 7 25 a.m. |
| 30 | 6:30 | 5:0 | 6:40 | 5:3 | 6:31 | 5:17 | 6:5 | 5:32 | |
| 31 | 6:30 | 5:0 | ... | ... | 6:31 | 5:18 | 6:4 | 5:33 | 27 " ☉ New Moon 8 59 " |

General Notes.

THE COTTON MARKET.

The following were the prices for cotton in London on 9th April, according to Messrs. Slann and Davies:—

| — | Good, Fair. | | Good. | | Fine. | | Superfine. | | COMPARE. | | | |
|---------------------|------------------|--------------------|------------------|----------------------|------------------|--------------------|------------|-------------------|-----------------|---------------------|-------------------|---------------------|
| | | | | | | | | | Good, 1907. | | Good, 1906. | |
| | d. | d. | d. | d. | d. | d. | d. | d. | d. | d. | d. | d. |
| Surat kinds* | 4 $\frac{5}{16}$ | to 4 $\frac{1}{2}$ | 4 $\frac{1}{2}$ | to 4 $\frac{15}{16}$ | 4 $\frac{1}{16}$ | to 5 $\frac{1}{4}$ | ... | ... | 4 $\frac{3}{4}$ | to 5 $\frac{3}{16}$ | 4 $\frac{13}{16}$ | to 5 $\frac{7}{16}$ |
| Madras | 4 $\frac{1}{2}$ | to 4 $\frac{1}{4}$ | 3 $\frac{1}{16}$ | to 5 | ... | ... | ... | ... | 4 $\frac{7}{8}$ | to 5 $\frac{5}{16}$ | 4 $\frac{7}{8}$ | to 5 $\frac{3}{16}$ |
| Bengal | ... | 3 $\frac{15}{16}$ | ... | 3 $\frac{9}{16}$ | ... | 3 $\frac{13}{16}$ | ... | 3 $\frac{31}{32}$ | ... | 3 $\frac{1}{2}$ | ... | 4 $\frac{1}{32}$ |
| Assam, &c. | ... | ... | ... | 4 $\frac{1}{2}$ | ... | 5 $\frac{1}{16}$ | ... | 6 | ... | 5 $\frac{1}{2}$ | ... | ... |
| China | ... | ... | ... | 4 $\frac{1}{2}$ | ... | 5 $\frac{1}{16}$ | ... | 5 $\frac{3}{8}$ | ... | 5 $\frac{1}{2}$ | ... | 5 $\frac{1}{16}$ |
| West Indian | ... | 6 | ... | 6 $\frac{3}{4}$ | ... | 7 $\frac{1}{4}$ | ... | 7 $\frac{3}{4}$ | ... | 6 $\frac{1}{2}$ | ... | 6 $\frac{1}{2}$ |
| Sea Island | ... | 7 $\frac{1}{2}$ | ... | 10 | ... | 15 $\frac{1}{2}$ | ... | 17 $\frac{1}{2}$ | ... | 11 $\frac{1}{2}$ | ... | 9 $\frac{1}{2}$ |
| Australia | ... | 6 $\frac{1}{2}$ | ... | 6 $\frac{1}{4}$ | ... | ... | ... | ... | ... | 6 $\frac{1}{4}$ | ... | 6 $\frac{1}{2}$ |

* Liverpool quotations.

A more cheerful feeling pervaded the market in the early part of the week ending 9th April, but a Continental failure, followed by heavy liquidations, caused a complete change in the position, and for several days prices have moved materially in favour of buyers. Spot middling is 12 points down to 5·67d., and "Futures" are 10 $\frac{1}{2}$ to 12 $\frac{1}{2}$ points lower for near, and 14 to 15 for distant. East Indian has met with a little more inquiry, but prices are about $\frac{1}{16}$ d. lower.

The import into Liverpool this week amounts to 31,524 bales, this year 1,602,894, same week last year 84,514, last year's total 2,146,297 bales. The estimated sales amount to 51,000 bales. Middling American is quoted at 5·67d. per lb.; last year, 6·12d.; 1906, 6·24d.; 1905, 4·24d.

The latest quotations of Americans for delivery, basis middling, any port, G.O.C., were:—

| | 9th April. | Last week. | Last year. |
|------------------|------------|-----------------------|------------|
| April | 5·21d. | 5·31 $\frac{1}{2}$ d. | 5·75d. |
| April-May | 5·19d. | 5·29 $\frac{1}{2}$ d. | 5·73d. |
| May-June | 5·19d. | 5·30 $\frac{1}{2}$ d. | 5·73d. |

Movement of American Cotton since 1st September.

| | 1907-8. | 1906-7. | 1905-6. | 1904-5. |
|---|-----------|------------|------------|------------|
| Brought into sight ... | 9,994,000 | 12,118,000 | 9,481,000 | 10,800,000 |
| Exports from United States since 1st September— | | | | |
| To Great Britain ... | 2,576,000 | 3,275,000 | 2,463,000 | 2,980,000 |
| To Continent, &c.... | 3,564,000 | 3,731,000 | 2,635,000 | 3,284,000 |
| Total crop | ... | 13,510,982 | 11,347,000 | 13,565,800 |

Cotton Seed.—Up at Liverpool 400 bags Peruvian sold at £5 15s. per ton on the quay. In London a large business is reported in Bombay, at a considerable advance, and Egyptian is also dearer. Sales include Egyptian spot in

London, £7 12s. 6d.; Hull, £7 10s.; Bombay, afloat, £6 6s. At the close, however, an easing down was noticeable, Egyptian spot, both in London and Hull, being quoted at £7 11s. 3d. .

British cotton-seed cake is quoted at £5 to £5 5s. ton, against £4 15s. to £4 17s. 6d. at this time last year.

Cotton-seed oil recently advanced 10s., but closed quieter, at £23 for crude, London, and £22 12s. 6d. for naked at Hull. Up at Liverpool the market for refined continues steady at £1 5s. 3d. to £1 5s. 9d. for edible, according to quality, and £1 4s. 9d. for ordinary.

MENDING BROKEN CAST IRON.

In the days when copper washing-boilers were almost unknown in Queensland, the cast-iron boiler was universally used by housewives on washing day. These were very liable to get cracked, and as there were no means of mending them, hundreds were thrown away as useless. At last, however, according to the Adelaide "Farm," the problem has been solved.

It has been the aim for many years of practical engineers to discover a cheap and expeditious method by which broken cast-iron parts of machinery could be satisfactorily mended. The discovery has at last been made, and, as frequently happens, it had its origin in the United States of America—the home of practical invention. "Weldarine" is the name of the principal flux used, in addition to specially-prepared borax and spelter.

The method of applying "Weldarine" is simplicity itself. All that is necessary is that the fracture should first be carefully cleaned by the use of a wire brush; then both parts must be covered with a paste made of "Weldarine" powder and fluid. After clamping or wiring the parts together, a coating of this paste is put $\frac{1}{2}$ -inch wide all around the joint; this coating is then dried, either by air or artificial heat, the part is brought to a cherry-red heat in the fire, "Weldarine" borax is applied, followed immediately by "Weldarine" spelter; the job allowed to cool down, and it is then complete.

Who could wish for anything more simple?

The highest value of the new medium is not the cost of the broken part—although that, too, is a great consideration—but is more the immense saving of lost time to the owner of broken-down machinery, which may occasion great inconvenience, and a loss in output which cannot be calculated. The application of the new substance, the efficacy of which has recently been so well demonstrated, has already saved one factory in Adelaide a very great deal of trouble and incalculable expense. This factory, the work of which is almost wholly carried out by machinery working in series, had a serious break-down in a casting on one of its machines. No spare parts of this machine were obtainable in Australia, so this meant that until the broken part was repaired or replaced the whole of the work of the factory which would pass through this machine must be kept back. In this desperate plight the factory manager telephoned for a mechanic, whom he knew had tried the "Weldarine" compounds, with the result that, within an hour the machine was repaired and the usual flow of work resumed. At a practical and highly successful demonstration given at the Adelaide March Show, a farmer stated that he had, by the use of "Weldarine" replaced one of two cogs stripped from the bull-wheel of a traction engine, and that, not being able to find the other cog, he had improvised one from an old piece of cast iron and "Weldarined" it on most successfully on a flat bed, without dowels or dovetailing.

At the Mount Barker show held last month a representative of "Art, Trade, and Industry" witnessed a number of most drastic tests of the application of the process, and was convinced that the veriest tyro could successfully

mend cast iron by using the "Weldarine" substances, with the aid only of an ordinary portable forge, a file, and a small vice. The most severe test was applied to two parts of a bar of cast iron measuring 1 inch in width by $\frac{1}{8}$ -inch in depth. These were first brazed together in the form of a T, the tail-piece resting upon the top of the cross-bar, and, after many attempts, the bar forming the tail-piece was broken off at right angles to the joint, carrying away with it a small portion of the cross-bar. This fracture was in turn treated in the ordinary method and duly mended, without interfering in any way with the first joint. After repeated attempts to break away this joint, the bar broke an inch below the mend. This new break was also made good, and the engineers and blacksmiths present merrily plied a heavy smith's hammer in the hope of breaking one of the three joints. The only result of their efforts was to break away one of the top pieces of the cross-bar of the T-piece, at right angles to the first joint, and also at right angles to the first fracture. The remarkable points about this test is that two of the joints were made by a novice in the art of brazing—thus proving that the work of using the materials can be carried out by anyone who will follow out instructions—and that the first three brazings successfully withstood the subsequent severe firings in the forge without the slightest damage.

The uses of "Weldarine" are not limited to cast-iron alone, as it has been amply demonstrated that it will braze cast iron to wrought iron or steel, or will braze either of these two metals themselves together. It should prove a cheap and expeditious method of joining together the ends of builder's bond iron, making a quick, safe, and neat joint, obviating the cumbersome and unsafe hooked ends which are commonly used. Many large contractors, coach-builders, and ironworkers in the United States have adopted the use of "Weldarine" for joining up wrought as well as cast iron, in order to ensure a neat as well as a durable junction. Why should we not in Australia follow so good an example?

Answers to Correspondents.

NITRE, BENZINE, Etc.

H. H., South Kolan—

1. Nitre is potassium nitrate, or saltpetre; spirits of nitre, or sweet nitre, is the pharmaceutical preparation: *Spiritus aetheris nitrici*, or *Spiritus aetheris nitrosi*.

2. Benzene, or benzol, is the hydrocarbon $C_6 H_6$; benzin, benzolene, gasolene, petroleum spirit, or naphtha, are mixtures of volatile hydrocarbons prepared on purification of crude petroleum containing chiefly Hexane $C_6 H_{14}$.

3. The last edition of Newth's "Inorganic Chemistry" was published in 1906.

4. Weight of green stuff per acre: The variations are so great that it is only possible to give a rough estimate. Wheat and barley should yield about 8 tons of green stuff to the acre; panicum, 9 to 10 tons; lucerne, 4 to 5 tons.

WHAT CONSTITUTES AN ACRE OF TOBACCO?

A. FONTAINE, Kelsey Creek, Bowen—

Mr. R. S. Neville, to whom your question was submitted, says:—"In tobacco, there is no commercial usage or necessity for creating imaginary areas; hence, an acre of tobacco is 10 square chains (1 by 10) of land planted in tobacco." In your letter you give 120 chains as an acre of sugar-cane. Does this not mean 12'0 chains?

The Markets.

PRICES FOR FRUIT—ROMA-STREET MARKETS.

| Article. | MAY. |
|--|--------------------|
| | Prices. |
| Apples, per case | 7s. to 10s. |
| Apples, New England, per packer | ... |
| Apricots, Local, per packer | ... |
| Bananas, Fiji, per case | ... |
| Bananas, Fiji, per bunch | ... |
| Citrons, per case | 10s. 6d. to 11s. |
| Cumquats, quarter-case | 1s. 6d. to 2s. 3d. |
| Cocoanuts, per dozen | ... |
| Custard Apples, per case | 3s. to 5s. 6d. |
| Lemons (Lisbon), per case | 2s. 6d. to 5s. |
| Lemons, rough, per case | 2s. to 2s. 6d. |
| Mandarins, per case | 2s. to 5s. 6d. |
| Oranges, per case | 1s. 6d. to 3s. 6d. |
| Passion Fruit (Local), per case | ... |
| Papaw Apples, per quarter-case | ... |
| Peaches, per quarter-case | ... |
| Pears, per case | ... |
| Persimmons, per case | ... |
| Pineapples, smooth, per dozen | 2s. to 5s. |
| Pineapples, rough, per dozen | 1s. 3d. to 4s. |
| Rosellas, per sugar bag | 2s. to 2s. 9d. |
| Strawberries, per tray | 2s. 6d. to 3s. |
| Strawberries, per dozen boxes | 6s. to 8s. 10d. |
| Tomatoes, per case | 2s. 6d. to 4s. 3d. |

SOUTHERN FRUIT MARKET.

| | |
|---|--------------------|
| Bananas, Fiji, per case | 14s. 6d. to 15s. |
| Bananas, Fiji, per bunch | 2s. to 9s. |
| Bananas, Queensland, per case | 12s. 6d. to 13s. |
| Bananas, Queensland, per bunch | 1s. 6d. to 6s. |
| Cocoanuts, per doz. | 2s. to 2s. 6d. |
| Lemons, coloured, per case | 6s. to 6s. 6d. |
| Lemons, small, per case | 3s. |
| Lemons, South Australian | 6s. to 7s. |
| Loquats, per case | 4s. |
| Mandarins, Emperor, per case | 7s. 6d. |
| Mandarins, B.G.R., per case | 3s. 6d. to 4s. 6d. |
| Mandarins, local | 7s. 6d. |
| Oranges, Queensland, per case | 5s. to 6s. |
| Oranges, Queensland, choice, per case | 7s. to 8s. |
| Oranges, medium, per case | ... |
| Passion Fruit, per case | 7s. |
| Peaches, Victorian, per box of 7½ dozen | ... |
| Peanuts, per lb. | 2½d. |
| Pears, per bushel case | ... |
| Pineapples, Queensland (Ripley's), per dozen | 5s. to 5s. 6d. |
| Pineapples, Queensland (smooth), per dozen | 5s. 6d. |
| Pineapples, Queensland, common, per dozen | 4s. 6d. |
| Persimmons, per case | ... |
| Pomegranates, per case | ... |
| Rockmelons, per gin case | ... |
| Strawberries, Queensland, per three-quart tray | 3s. 6d. to 4s. 6d. |
| Tomatoes, per box | 4s. 6d. |

PRICES OF FARM PRODUCE IN THE BRISBANE MARKETS FOR
JUNE.

| Article. | | JUNE. | |
|------------------------|-------|---------------------|--|
| | | Prices. | |
| Bacon, Pineapple ... | lb. | 6½d. to 8d. | |
| Bran ... | ton | £7 10s. | |
| Butter, Factory ... | lb. | 1s. 1½d. | |
| Chaff, Mixed ... | ton | £3 to £5 10s. | |
| Chaff, Oaten ... | " | £6 5s. to £8 10s. | |
| Chaff, Lucerne ... | " | £4 15s. to £6 10s. | |
| Chaff, Wheaten ... | " | £3 15s. to £4 5s. | |
| Cheese ... | lb. | 8½d. to 9d. | |
| Flour ... | ton | £10 15s. to £11 | |
| Hay, Oaten ... | " | £8 to £8 10s. | |
| Hay, Lucerne ... | " | £4 5s. to £5 10s. | |
| Honey ... | lb. | 3d. to 3½d. | |
| Maize ... | bush. | 4s. 2½d. to 4s. 4d. | |
| Oats ... | " | 3s. 9d. to 4s. 3d. | |
| Pollard ... | ton | £7 10s. | |
| Potatoes ... | " | £4 to £6 | |
| Potatoes, Sweet ... | " | ... | |
| Pumpkins ... | " | ... | |
| Wheat, Milling ... | bush. | 5s. 3d. | |
| Wheat, Chick ... | " | 4s. 9d. to 5s. | |
| Onions ... | ton | £8 5s. to £8 15s. | |
| Hams ... | lb. | 11d. to 1s. | |
| Eggs ... | doz. | 1s. 4d. to 1s. 10d. | |
| Fowls ... | pair | 2s. 6d. to 4s. | |
| Geese ... | " | 5s. to 6s. 9d. | |
| Ducks, English ... | " | 3s. to 4s. 10d. | |
| Ducks, Muscovy ... | " | 4s. 3d. to 4s. 9d. | |
| Turkeys (Hens) ... | " | 6s. 9d. | |
| Turkeys (Gobblers) ... | " | 11s. to 13s. | |

ENOGGERA SALEYARDS.

| Animal. | | MAY. | |
|-----------------|-----|-----------------------|--|
| | | Prices. | |
| Bullocks ... | ... | £7 10s. to £9 2s. 6d. | |
| Cows ... | ... | £6 2s. 6d. to £8 | |
| Merino Wethers | ... | 17s. 6d. | |
| C.B. " | ... | 19s. 3d. | |
| Merino Ewes | ... | 15s. | |
| C.B. " | ... | 21s. 6d. | |
| Lambs ... | ... | 13s. 6d. | |
| Pigs (Baconers) | ... | ... | |
| " (Porkers) | ... | ... | |

Orchard Notes for August.

By ALBERT H. BENSON, M.R.A.C.

THE SOUTHERN COAST DISTRICTS.

The remarks that have appeared in these notes during the last few months respecting the handling and marketing of citrus fruits apply equally to the present month. The bulk of the fruit, with the exception of the latest ripening varieties in the latest districts, is now fully ripe, and should be marketed as soon as possible, so that the orchards can be got into thorough order for the spring growth. All heavy pruning should be completed previous to the rise in the sap; and where winter spraying is required, and has not yet been carried out, no time should be lost in giving the trunks, main branches, and inside of the trees generally a thorough dressing with the lime and sulphur wash.

Where there are inferior sorts of seedling citrus trees growing, it is advisable to head same hard back, leaving only the main trunk and four or five well-balanced main branches cut off at about 2 feet from the trunk. When cut back give a good dressing with the lime and sulphur wash. Trees so treated may either be grafted with good varieties towards the end of the month, or early in September; or, if wished, they may be allowed to throw out a number of shoots, which should be thinned out to form a well-balanced head, and when large enough should be budded with the desired variety.

Grafting of young stock in nursery, not only citrus but most kinds of deciduous fruits, can be done this month. It comes in useful in the case of stocks that have missed in budding, but for good clean-grown stocks I prefer budding.

In the case of working our Seville orange stocks to sweet oranges, grafting is, however, preferable to budding, as the latter method of propagation is frequently a failure. The Seville stock should be cut off at or a little below the surface of the ground. If of small size, a single-tongue graft will be sufficient, but if of large size, then the best method is the side graft—two or more grafts being placed in each stock, so as to be certain of one taking. In either case the grafts are tied firmly in place, and the soil should be brought round the graft as high as the top bud. If this is done, there will be few misses, and undesirable Seville stocks can be converted into sweet oranges.

In selecting wood for grafting, take that of the last season's growth that has good full buds, and that is well-matured—avoid extra strong, or very poor growth.

Seville oranges make good stocks for lemons. In case it is desirable to work them on to lemons, it is not necessary to graft below ground, as in the case of the sweet orange, but the stock can be treated in the same manner as that recommended in the case of inferior oranges—viz., to head hard back, and bud on the young shoots.

Where orchards have not already been so treated, they should now be ploughed so as to break up the crust that has been formed on the surface during the gathering of the crop, and to bury all weeds and trash. When ploughed, do not let the soil remain in a rough, lumpy condition, but get it into a fine tilth, so that it is in a good condition to retain moisture for the trees' use during spring. This is a very important matter, as spring is our most trying time, and the failure to conserve moisture then means a failure in the fruit crop, to a greater or lesser extent.

When necessary, quickly-acting manures can be applied now. In the case of orchards, they should be distributed broadcast over the land, and be

harrowed or cultivated in; but, in the case of pines, they should be placed on each side of the row, and be worked well into the soil.

The marketing of pines, especially smooths, will occupy growers' attention, and where it is proposed to extend the plantation the ground should be got ready, so as to have it in the best possible condition for planting, as I am satisfied that the thorough preparation of the land prior to planting pines is money very well spent.

The pruning of all grape vines should be completed, and new plantings can be made towards the end of the month. Obtain well-matured, healthy cuttings, and plant them in well and deeply worked land, leaving the top bud level with the surface of the ground, instead of leaving 6 or 7 inches of the cutting out of the ground to dry out, as is often done. You only want one strong shoot from your cutting, and from this one shoot you can make any shaped vine you want. Just as the buds of the vines begin to swell, but before they burst, all varieties that are subject to black spot should be dressed with the sulphuric acid solution—viz., three-quarters of a pint of commercial sulphuric acid to one gallon of water; or, if preferred, this mixture can be used instead—viz., dissolve 5 lb. of sulphate of iron (from copperas) in one gallon of water, and when dissolved add to it half a pint of sulphuric acid.

TROPICAL COAST DISTRICTS.

Bananas should be increasing in quality and quantity during the month, and though, as a rule, the fruit fly is not very bad at this time of the year, still it is advisable to take every care to keep it in check. No over-ripe fruit should be allowed to be about in the gardens, and every care should be taken to keep the pest in check when there are only a few to deal with, as, if this is done, it will reduce the numbers of the pest materially later on in the season. The spring crop of oranges and mandarins will be now ready for marketing in the Cardwell, Tully, Cairns, and Port Douglas districts. For shipping South see that the fruit is thoroughly sweated, as unless the moisture is got rid of out of the skins the fruit will not carry. Should the skins be very full of moisture, then it will be advisable to lay the fruit on boards or slabs in the sun to dry; or, if this is not possible, then the skin of the fruit should be artificially dried by placing same in a hot chamber, as the moisture that is in the skin of our Northern-grown citrus fruits must be got rid of before they will carry properly.

Papaws and granadillas should be shipped South, and the markets tested. If carefully packed in cases holding only one layer of fruit, and sent by cold storage, these fruits should reach their destination in good order. Cucumber and tomato shipments will now be in full swing from Bowen. Take care to send nothing but the best fruit, and do not pack the tomatoes in too big cases, as tomatoes always sell on their appearance and quality.

SOUTHERN AND CENTRAL TABLELANDS.

All fruit-tree pruning should be finished during the month, and all trees should receive their winter spraying of the lime and sulphur wash.

All new planting should be completed, orchards should be ploughed and worked down fine, and everything got ready for spring.

In the warmer parts grape-pruning should be completed, and the vines should receive the winter dressing for black spot. In the Stanthorpe district grape-pruning should be delayed as late as possible, so as to keep the vines back, as it is not early but late grapes that are wanted, and the later you can keep your vines back the better chance they have of escaping spring frosts.

Towards the end of the month inferior varieties of apples, pears, plums, &c., should be worked over with more desirable kinds; side, tongue, or cleft grafting being used. In the case of peaches, almonds, or nectarines, I prefer to head back and work over by budding on the young growth.

Farm and Garden Notes for August.

This and the following two months are about the busiest periods of the year so far as work in the field is concerned; and the more activity now displayed in getting in the summer crops the richer will be the reward at harvest time. Potatoes should be planted, taking care to select only good sound seed that has sprouted. This will ensure an even crop. Yams, arrowroot, ginger, sisal hemp, cotton, and sugar-cane may now be planted. Sow maize for an early crop. If the seed of prolific varieties is regularly saved, in the end it will not be surprising to find from four to six cobs on each stalk. This has been the experience in America, where the selecting of seeds has been reduced to a fine art.

In choosing maize for seed, select the large, well-filled, flat grains. It has been shown that, by constantly selecting seed from prolific plants, as many as five and six cobs of maize can be produced on each stalk all over a field. A change of seed from another district is also beneficial. Sow pumpkins, either amongst the maize or separately, if you have the ground to spare. Swede turnips, clover, and lucerne may be sown, but they will have to contend with weeds which will begin to vigorously assert themselves as the weather gets warmer; therefore keep the hoe and cultivator constantly going in fine weather. Tobacco may be sown during this month. If vines are available, sweet potatoes may be planted towards the end of the month. In this case also it is advisable to avoid too frequent planting of cuttings from the old vines, and to obtain cuttings from other districts. If grasses have not yet been sown, there is still time to do so, if the work be taken in hand at once. Sugar-cane crushing will now be in full swing, and all frosted cane in the Southern district should be put through the rollers first. Plough out old canes, and get the land in order for replanting. Worn-out sugar lands in the Central and Northern districts, if not intended to be manured and replanted, will bear excellent crops of sisal hemp. Rice and coffee should already have been harvested in the North. The picking of Liberian coffee, however, only begins this month. Collect divi-divi pods. Orange-trees will be in blossom, and coffee-trees in bloom for the second time. As this is generally a dry month in the North, little can be done in the way of planting.

Kitchen Garden.—Nearly all spring and summer crops can now be planted. Here is a list of seeds and roots to be sown which will keep the market gardeners busy for some time: Carrots, parsnip, turnip, beet, lettuce, endive, salsify, radish, rhubarb, asparagus, Jerusalem artichoke, French beans, runner beans of all kinds, peas, parsley, tomato, egg-plant, sea-kale, cucumber, melon, pumpkin, globe artichokes. Set out any cabbage plants and kohlrabi that are ready. Towards the end of the month plant out tomatoes, melons, cucumbers, &c., which have been raised under cover. Support peas by sticks or wire-netting. Pinch off the tops of broad beans as they come into flower to make the beans set. Plough or dig up old cauliflower and cabbage beds, and let them lie in the rough for a month before replanting, so that the soil may get the benefit of the sun and air. Top-dressing, where vegetables have been planted out, with fine stable manure has a most beneficial effect on their growth, as it furnishes a mulch as well as supplies of plant food.

Flower Garden.—All the roses should have been pruned some time ago, but do not forget to look over them occasionally, and encourage them in the way they should go by rubbing off any shoots which tend to grow towards the centre. Where there is a fine young shoot growing in the right direction, cut off the old parent branch which it will replace. If this work is done gradually

it will save a great deal of hacking and sawing when next pruning season arrives. Trim and repair the lawns. Plant out antirrhinums (snapdragon), pansies, hollyhocks, verbenas, petunias, &c. Sow zinnias, amaranthus, balsam, chrysanthemum, marigolds, cosmos, coxcombs, phloxes, sweet peas, lupins; and plant gladiolus, tuberoses, amaryllis, pancratium, ismene, crinums, belladonna, lily, and other bulbs. In the case of dahlias, however, it will be better to place them in some warm moist spot, where they will start gently and be ready to plant out in a month or two. It must be remembered that this is the driest of our months. During thirty-eight years the average number of rainy days in August was seven, and the mean average rainfall 2·63 inches, and for September 2·07 inches, increasing gradually to a rainfall of 7·69 inches in February.

 Agriculture of VICTORIA

PRICKLY PEAR AS FODDER.

Some time ago, Mr. R. T. Keys, Muswellbrook, wrote on the above subject to the "Stock and Station Journal," and we draw attention to his remarks, as some people have a firm belief in the value of the pear, not only as a life-sustainer in dry seasons, but even as a fattening fodder. Mr. Keys' remarks are as follow:—

By advocating the use of the noxious weed at this adverse period of our history, when stock-owners are eager to discover drought-resisting plants, much injury may be done to the pastoral industry by causing some graziers to relax their efforts in the eradication of prickly pear, on account of men of standing hastily giving it a fictitious value, and mayhap thus cause valuable properties to be overrun with the pest in a year or two, and rendered worthless. In a conversation I had with Mr. Maiden, the well-known botanist, and Curator of the Sydney Botanical Gardens, a year or two ago, we discussed the question of the utility of prickly pear for fodder, and he assured me that analyses by himself and other scientists had proved beyond doubt that the earth does not produce a plant with less nutriment for stock than the prickly pear, and he accordingly urged every true friend of the pastoral industry, and consequently patriotic son of the State, to never lose an opportunity in helping on the work of its eradication. "If," added Mr. Maiden, "you were to put a handful of pollard into a 400-gallon tank filled with prickly pears, that small quantity of pollard would have more life-sustaining nutriment for stock than the whole of the pears with which it had been mixed."

Mr. F. S. Bell, of Pickering, who has had a life-long experience as a grazier, recently put the prickly pear to a thorough test, and no greater object lesson was ever given in New South Wales of its utter worthlessness as fodder than that which resulted from the comprehensive experiments of my esteemed neighbour. Like all stock-owners, Mr. Bell was severely affected by the drought, and could have turned his cattle into a large paddock covered with prickly pear; but, having had forty years' experience of the plant, he felt certain that trying to graze stock upon it would be useless; but he resolved to thoroughly test it otherwise, and prove if it were able to sustain his stock, and capable of helping them through the severely dry time we were experiencing. He therefore had considerable quantities of the prickly pear plants cut, and went to great expense in erecting pots in different parts of his paddocks for the thorough boiling of the pears. In this way he fed 400 bullocks for nearly three months, but they did no good on the prepared pear fodder, became poorer from week to week, until at last Mr. Bell had to send them away to the coast to save their lives.

No better trial of the value of the pear than the foregoing was ever given in Australia, and no more experienced or practical man to deal with the subject under notice can be found in the Commonwealth than the gentleman who made the test. Yet, in the face of this lifelong experience and complete test, Mr. Peele will contend that cattle were fattened at Womblebank on the worthless and noxious plants. I might also be permitted to point out to Mr. Peele, and anyone who may think with him, that the Hunter River stock-owners have had more experience of prickly pear than the graziers of any other part of Australia, inasmuch as the noxious weed was first brought to Scone in the thirties, and they are unanimous in condemnation of the pest; a number of the most experienced of them having recently had miles of prickly pear to put their stock on, had they so desired, but they sent their cattle to the coast, knowing that it would be madness to try and keep them alive on the noxious plant.

With regard to the Womblebank bullock theory, an old Womblebank stockman who has been recently visiting Muswellbrook has given me what seems to be a correct version of the pear-fattening story, and a very reasonable explanation of how the fattening of the stock in question was effected. It appears that at Womblebank there is an extensive growth of pears that covers an area of 15 miles, but the vegetable products on that portion of land do not consist solely of prickly pears, for an exploration of the locality disclosed the fact that it contained patches of good grass 10, 15, and 20 acres in extent, which had been preserved by the surrounding growth of pears, that, barrier-like, had kept cattle out until the great scarcity of food caused the bullocks to break through and reach the grass, which, although old and dry, was still nutritious, and enabled the bullocks to preserve their condition when stock in other parts of the run wasted away, the pears, as explained, therefore getting undeserved credit for the fattening result.

I am well aware that Mr. Peele is as much interested as anyone else in the welfare of the State, and strongly desirous of promoting the pastoral industry; but his ill-advised, though strong, advocacy of the use of the prickly pear, by influencing others, might some day cause an intelligent Government to take steps to protect the noxious weed to the general detriment of the landholders of the country. It is, therefore, to be hoped that he will discontinue his advocacy of the use of the pear till possessed of full information in its regard, and which I am sure will convince him of its worthlessness.

I will concede that stock will eat prickly pear when all edible grass and scrub have failed, and while feeding on it will require little or no water; but they will never thrive on it, as has been conclusively proved by the illustrations given.

Anyone who will take the trouble to open beasts that have been fed on prickly pear will see the mouths and entrails penetrated with thorns, and then realise the cruelty, as well as the futility, of giving the animals such food.

PREPARATION OF PRICKLY PEAR FOR STOCK.

Referring to an article in the last issue of the Journal on the above subject, we now give a few illustrations taken from Bulletin No. 74 of the United States Department of Agriculture, showing the method of dealing with the pear in Texas. By the use of the pear-cutting machine here shown, the cactus may be chopped into such small pieces that the spines are rendered innocuous by the abrasion. The machine consists mainly of a solid cast-iron wheel, 4 feet in diameter, with two knives arranged at a narrow angle with the radius on one of its faces. Behind each knife, hollowed out of the face of the casting, there is a pocket extending the length of the radius. The front face of the wheel is plain, save for these pockets, which receive the chopped pear, and carry it out of the machine. The pockets are $1\frac{1}{4}$ inch deep, 22 inches long, and 9 inches wide. When the machine is set up, a short chute is bolted at an acute angle with the face of the vertical wheel. The pear is forked into this chute, fed against the revolving knives, and is cut and mashed into small pieces. By the help of this machine, ten men can cut a full ration for 2,000 head of cattle.

The pear burners here depicted were fully described in the July issue of the Journal.

With respect to the value of pear fodder for stock, it is said to be universally recognised throughout the pear region of Texas that the plant has a decided tendency to increase the flow of milk; but it is always used as a supplementary ration, combined with hay and bran, more for the sake of its succulence than for any feeding value it may possess, green feed being an essential for milk production during the winter, and that is furnished by the prickly pear during that portion of the year when there is no green feed.



1. Prickly Pear Cutter.
2. A Pear Thicket in Texas.
3. Prickly Pear of Texas in Full Fruit.

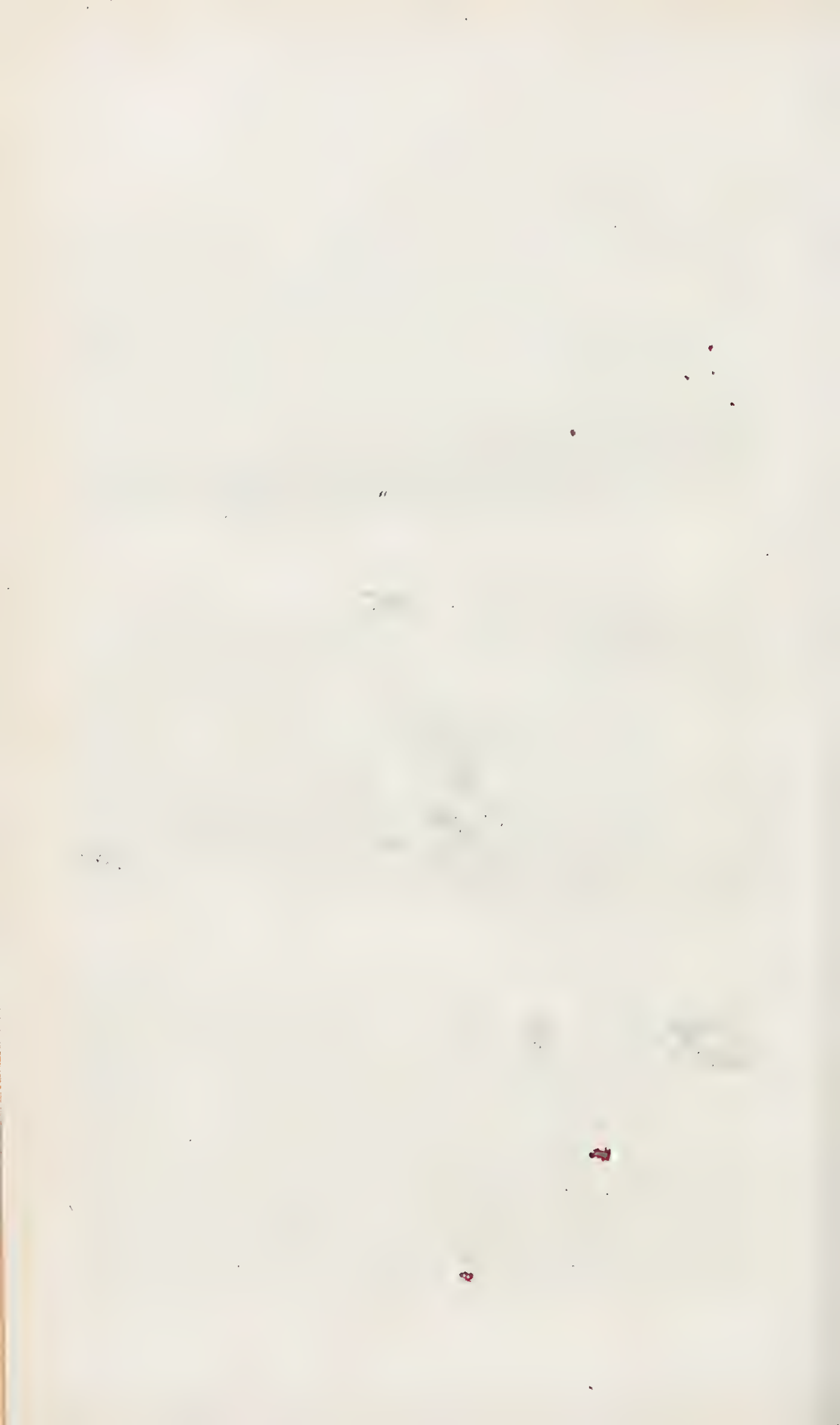



1. The Cane Cactus of Colorado, singed with Brush.
2. The Prickly Pear of Texas, singed with a Torch.
3. Nopal de Castilla, cultivated in Southern California.

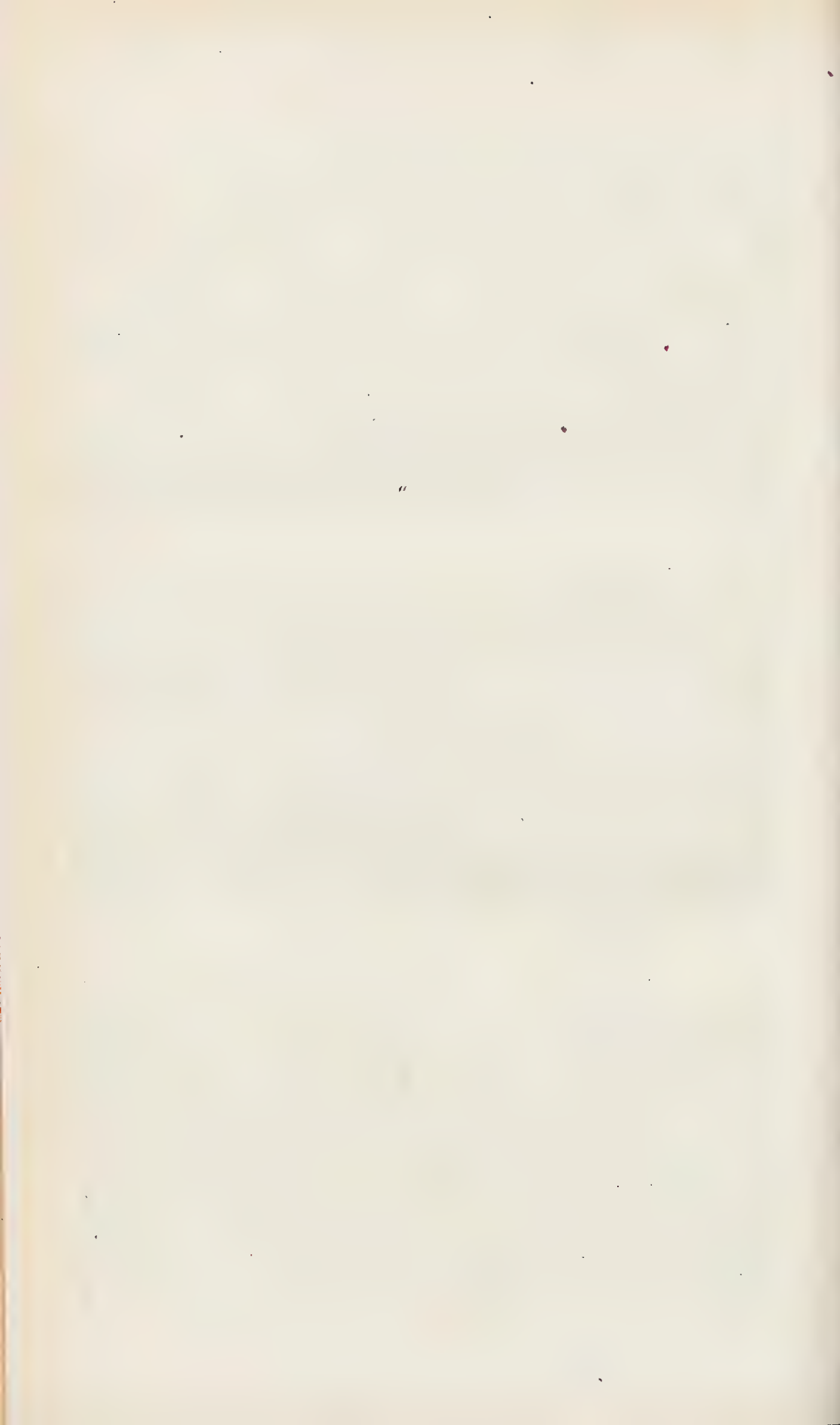

CHANGE OF SEEDS.

Certain remarks made by a writer in the "Revue Agricole" (Reunion) are intended as a warning to planters who believe that change of seed necessarily leads to the improvement of strain or of crops. The writer says that it is almost a general rule in "our countries" to change the seeds periodically. After the seeds grown on an estate have been employed for sowing purposes for two or three years consecutively, recourse is had to seeds foreign to the estate, which are obtained in the market from quarters the most renowned for seeds of good quality, which are sown in order to renew the strain. "Planting Opinion" says that we might ask if this traditional practice is justifiable, and if it would not be more profitable in the majority of cases to allow seeds to produce their own, and that to an indefinite period. He thinks that that would be much better, and that "in our district at least" they would be much benefited by it. M. d'Aygalliers argues that the only reason which militates in favour of the change or of the renewal of the seeds consists in the degeneracy of those that agriculturists collect themselves—degeneracy that grows worse year after year. But, he asks, why should this unfortunate state of degeneracy be allowed to take place? Could we not avoid it by removing its causes? This appears to him not only possible, but easy as well. He rightly says that as we have recourse to new varieties originating from soils and climates differing from those where we place them, it must be naturally expected that these foreign varieties growing under unfavourable conditions would unfortunately degenerate gradually. In order to preserve all these advantages in their cultivation, we would be then obliged to renew the seeds all the oftener, inasmuch as the deterioration would be more rapid, and to fetch them from countries where these varieties enjoy the most favourable conditions. But we cultivate only plants naturalised in our midst for a long time, and local varieties established for a number of years. These, besides, go to prove clearly that it is not the change of place, not more the result of the soil than that of the climate, that can bring about deterioration. When we wish to renew the seeds we do not go to fetch them from different centres. If our seeds degenerate or deteriorate, the only cause to which this can be attributed is to defective cultivating conditions. Now, while powerless to modify the effects of climate and soil, we are perfectly free to modify as we like the procedure and care of cultivation. It will suffice us to bring them to perfection, so that we may ourselves obtain strong and sound seeds.

It is apparent from these remarks that the writer's line of reasoning is that a planter should rely rather upon seed carefully cultivated under his own care than upon seed grown by others. A good deal might be said in support of this, but it must be remembered that the careful cultivation of seed makes a heavy call upon the time and attention of planters, and that there must be many instances in which it is better to import seeds from a well-known cultivation rather than devote special care to the raising of one's own. The writer states that it is specially important to set apart specially, for the cultivation of plant-bearing seeds, a piece of land proportionate to the quantity of seeds we wish to obtain. We can thus give to the plants producing seeds for sowing purposes the care which it is not always possible to give to plants of large growth, by way of tilling, weeding, watering, &c. The crop will take place after complete maturity; the thrashing will be carefully done; the seeds thus obtained will be cleaned and picked with care. The picking is an indispensable operation in order to obtain sowing seeds of the soundest quality. It is to the want of sufficient care under this head that the deterioration of seeds in our estates must be solely attributed. They are, in fact, satisfied with cleaning them with a winnowing machine, which still leaves seeds of good quality mixed with bad and unsound ones, and, what is worse, with those of ill-weeds. If after the cleaning of the seeds by the winnowing process they are allowed to pass through a cellular picker, not only would the bad seeds fall apart, but the good ones also would be separated according to their size into two classes—the first and second quality.

It seems needless to say that the seeds of the first quality alone—bigger and stronger than the others—should be employed for sowing purposes. Even good cultivators, however, have been several times seen to mix up the two qualities for sowing, thus rendering useless the separation made by the picker. Others again sell the seeds of the first quality, sowing only those of the second, and thus lose the best advantage that the picking gives them. For a slight immediate profit they compromise the success of their future crop. It is only in modifying this system of vitiating the seeds, and in striving to make a good selection of them by all possible means, that we could ourselves succeed in producing sound seeds for sowing. Then alone could we do away with the practice of going about the market to find suitable seeds for sowing, and for which we generally pay very dear.

DESTRUCTION OF CHARLOCK.

Wherever charlock grows plentifully in wheat fields considerable loss results to the farmer in that it smothers young plants, but its effects are less manifest in early-sown than late-sown spring corn. It sucks the substance from the land. Its large exposure of leaf surface exhales so much moisture that it deprives the roots of a corresponding quantity. This is particularly apparent on light and dry soils. Seeds sown along with corn feel the pinch of competition when the charlock has been very severe. It is known to be a host of the finger-and-toe fungus, and likewise the turnip-flea beetle and turnip weevil, as well as other insects, feed on it.

Thus it is one of the worst because one of the commonest of pestiferous weeds, whose familiar yellow flower is seen in many parts of the country, and much money has been spent, not always fruitfully, in the endeavour to exterminate it by altering rotations, extra cultivation, and other means. It is pointed out that the rough-leaved charlock should be distinguished from the smooth, the rough leaves being an important factor in the extermination of the weed by spraying. The seeds of charlock, owing to their oily nature, are long-lived, and this vitality has been a source of trouble on every farm. When ley is ploughed preparatory to oats, the seeds that have been buried come to the surface and germinate. In the ordinary course of ploughing, the stubble buries these seeds at a depth sufficient to keep them dormant, but they return to life when brought to the surface again.

The best method of dealing with the pest is by spraying, and this is successfully done in an English farming district, the requisite conditions being:—Proper mixing of the sulphate of copper, which should be finely crushed and of purity of 98 per cent., clean water, the solution being put through a canvas bag into the spraying machine; fine weather at the time of application, and the application of the spray either when the plant is from 3 to 4 inches high or in the flowering stage.

The method of preparing the solution is as follows:—Take, say, 15 lb. of sulphate of copper and a few gallons of cold water in a wooden tub; dissolve and dilute with water to 50 gallons, which is equivalent to a 3 per cent. solution. The cost of this solution per acre is 4s. 6d., and, allowing that 20 acres are sprayed in a day with a twelve-nozzle machine, the total cost per acre is 5s. 3d. for materials and labour.

To apply the solution, a machine used in Lancashire is suitable for attaching to a farm cart. It consists of a wooden barrel placed on the body of the cart and large enough to hold 50 gallons of water. A pump is screwed to the bottom of the cart, with an outlet tube connected to the base of the barrel. The apparatus for distributing the spray is lashed securely to the back of the cart, being connected by means of a rubber tube to the outlet side of the pump. Two men are required to apply the spray evenly, one to work the pump and the other to lead the horse, a strip of land about 5 yards wide being sprayed at each

round. That, of course, is a primitive form of sprayer, but it can be had especially made for the purpose, and a good plan would be for farmers to combine to purchase one.

Results of spraying in Lancashire indicate that in suitable weather, when the plant is sprayed in its young state, more than 75 per cent. of the charlock plant has been completely destroyed, and where actual death has not resulted growth has been sufficiently retarded to enable the corn to push ahead. To complete the operation and make an entire success of it, it is better to repeat the spraying about a fortnight after the first. It appears to be immaterial whether sprayed in the flower or in the young stage. Results appear to vary. Those with smaller farms can apply the spray at the rate of 3 acres a day from an ordinary knapsack sprayer.

STATE FARMS.

Although the month of July was a very inauspicious season in which to pay a visit to a State or any other farm, owing to the long-continued dry weather and frosts, there is always something to be learnt at the State farms at all times of the year. We lately paid a visit to the Hermitage State Farm, near Warwick, and that at Westbrook, near Toowoomba. To the casual visitor there was apparently nothing to attract particular attention. Both these institutions have long been famed for the success which has attended the experiments there made every year in wheat culture, more particularly in producing rust-proof varieties, whilst the Westbrook Farm is also celebrated for the splendid fruits and grapes raised in addition to field crops and new varieties of grasses. At the time of our visit nothing was to be seen in the cultivation paddocks either here or on outside farms in the shape of cereal crops. The ground had long since been prepared for the seed, but the persistent dry weather had prevented all but very small sowings. Where the fields should by this time have been green with early wheat, nothing was to be seen but large areas of ploughed land awaiting the longed-for downpour to enable sowing to be done before it is too late. Should rain fall before August, there may yet be a bountiful harvest, as on more than one occasion excellent yields were obtained from fields sown as late as the middle of August. To the reflective, unbiassed mind, the State farms are carrying out excellent work for the benefit of the agricultural as well as other portions of the community. The Department of Agriculture and Stock long ago recognised that its first duty is to take the initiative in agricultural education, and that duty has been systematically performed. To provide such education for the young people growing up is, however, only part of the work. If the education is confined to these, the process of improvement of agriculture would be very slow in producing good results. Provision had, therefore, to be made for instructing those more advanced in years. "Who wants agricultural education?" asked Sir Edward Verney, in an English newspaper. "Not the labourer," he said; "not the farmer, very seldom the land-owner. The people who want it most are those who know least about agriculture." But there are farmers and farmers. There are in all farming districts of this State skilled farmers who study their surroundings, and by their skill and experience overcome all difficulties, and skill and industry usually mean success. On the other hand, there are men settled on our lands who have had no previous agricultural training, and who, hence, often fail. If the skilled and successful farmer has need to prepare for the inevitable coming struggle for a place in the markets of the world, how much more so is it necessary for the comparatively inexperienced farmer to do so? It may here be remarked that it is mainly the skilled, experienced, and successful farmers who pay the most regular visits to the Agricultural College and State farms. They recognise that private, isolated efforts are no longer sufficient to enable them to face with success the world's

competition, and that by abstaining from taking object lessons at the Government farms they would be courting failure by continuing always on the same old lines or by making expensive experiments which frequently end in failure. There is no agriculturist living that has not something more to learn, and with us the varying degrees of skill and knowledge possessed by our existing farmers open a wide field for the specialists, instructors, and managers of the experimental farms of the Department. There are people who are short-sighted enough to believe that a State farm should be self-supporting. If those holding this belief would study what is being done by experimental farms in other countries and think the matter out, they could not but come to the conclusion that such farms amply justify the money spent on them by the work they do in saving individual farmers from heavy losses. Many of the drawbacks from which the farmers have suffered, such as losses by floods, droughts, frosts, and manifold plant diseases, have been considerably minimised by scientific discoveries in many lands, where experiments with this in view have cost the Governments many thousands of pounds; but, on the other hand, the successful results have saved many more thousands to the farmers by doing for them what it would have been impossible for them to do for themselves.

Each of our State farms has become more or less specialised for the particular products found most suitable for its district, and "at each science in various ways has come to the farmers' aid, and has opened up hitherto undreamed-of possibilities in raising the yield of produce, in reducing the cost of production, and in developing new methods of treating the increased crops. Those amongst us who have seen the beginning of the sugar industry in Queensland cannot fail to acknowledge the enormous value of the science of chemistry, by which a ton of sugar, which in the early days required from 15 to 20 tons of cane to produce, can now be produced from 7 tons and even from 6 tons. In the same way the cotton seed, which Queensland farmers used to throw away, is now worth more than the lint itself. But there is no need to enumerate the multifarious ways in which scientific teaching has come to the farmer's aid, and has raised their occupation to the dignity of a profession. In our own State, the Hermitage State Farm has for years been engaged in the business of experimenting with new wheats, the Department importing them at considerable expense, and out of which, perhaps, only a few might be found of value, thus saving the farmer from possible heavy loss. Last year, for instance, a wheat evolved by hybridisation at the Hermitage yielded 40 bushels per acre at Allora. This was named Hermitage No. 2. Another wheat, No. 52, received from the South Australian Department of Agriculture, has been grown for three years with excellent results, so much so that that Department requested a quantity of it to be sent to them every year. On one plot of 28 acres there were 18 varieties grown, and 9 special varieties on another plot, and, taking the average right through, the yield was 17 bushels per acre, notwithstanding the adverse season. On this farm also there are a number of olive-trees, the produce of which was sold to some Italians at 5s. per tree, and the buyers picked them themselves. There are a number of varieties of valuable nomenclature wheats sown, but not yet above ground. Again, much attention is paid to grasses, and it is due to the experimenting with new grasses at the State farms that dairymen have now such splendid grasses, as *paspalum*, *Rhodes*, and canary grass. The latter appears to stand both heat, drought, and frost well, in fact, where the *paspalum* was cut down by the frost the *Phalaris* showed up beautifully green. Valuable stock has also been imported to be reared on the farm, in the shape of pigs, cattle, and Clydesdale mares (which now have foals at foot), at a cost not within the reach of all farmers, but which subsequently they can purchase at very reasonable prices. It is on this farm that may be seen the fine pure merino sheep presented to the Department by Mr. Slade, of Glengallan, which station has for so many years been famous for its breed of purebred sheep. There are 50 of these valuable animals, and they have been lately increased by the birth of 81 lambs. The ewes cut a fleece of 10 lb. and ewe-lambs 5 lb.; ram lambs, 4 lb.

Some students are taken at this farm, who receive a certain amount of pay in addition to instruction in general farm work. They are provided with excellent quarters, and will doubtless turn out good farmers when they take up land for themselves, as they will have had a very varied experience at the Hermitage.

At the Hermitage there is a very imposing-looking silo, constructed of fibro-cement. Here, again, in the matter of silos the Department has provided object lessons for farmers. It is a serious matter for a farmer, however well-to-do, to go to an expenditure of over £100 in experimenting on silo buildings; but he is relieved of this work by experiments at the Agricultural College and the State farms. This particular silo was built as an experiment, and it is stated that some farmers who had the intention of building one have come to the conclusion that the structure has three disadvantages. The first is, that the binding is not sufficiently strong to hold it together; the second, that the panels are too large and too thin ($\frac{1}{4}$ -inch thick) to resist outward pressure; and the third, that the material is easily broken by a fork or rake. If these allegations are correct, it follows that several farmers have been saved an expenditure of much money on erecting buildings which they say would not serve their purpose so well as some different form of silo. Lately, however, the two first disabilities—*i.e.*, the binding and the thinness of the material—have been successfully dealt with.

At the Hermitage there is a milking-shed for four cows 24 feet by 20 feet. The manager pointed out to us a method of working by which the same shed could be utilised for forty cows, as demonstrated to him by a visitor from New Zealand.

Turning to the State farm at Westbrook, we find that the manager is doing excellent work, far-reaching in its effects, in connection with orchard and vineyard, over and above his valuable work on experimental wheats. The trees present, of course, the usual wintry aspect assumed by deciduous trees in the winter, but all are symmetrically pruned, and during the spring and summer are laden with blossom and fruit. It is a matter of surprise to some that this farm does not produce large quantities of various varieties of fruit for supplying the market; but such a course would defeat the very object for which the orchards have been established. And here we find the same conditions as at the Hermitage—that is, the instruction of fruit-growers in the cool districts of the Darling Downs. All fruit-growers know, to their cost, the losses which have been sustained by planting imported trees, named and labelled according to catalogue, but when at last they began to bear they were frequently found to be quite other than what they purported to be. They were either inferior varieties or shy bearers, or liable to disease, or were not true to name. In such cases the purchaser lost at least five years' labour, and either had to give up fruit-growing or begin again. Here is where the great advantage of a State orchard comes in. At Westbrook there are 310 trees of various kinds grown to prove their suitability or otherwise for the Downs country. In most instances there are only three or four of each kind, so that large supplies of one description of fruit cannot be supplied, nor is it intended that they should be, the main object, as we have said, being to show what should be grown and what should be avoided. For instance, there are 200 trees on the farm which the manager has proved to be such as he could not recommend any farmer to plant.

The same with the grape vines, of which there are 210 also of different varieties. Most of these have been selected year after year, until only the best varieties of table and wine grapes are grown. All this entails large expense and a most voluminous correspondence with all parts of the Australian States and also foreign countries, as inquiries come from very many sources. This outlay is entirely saved to farmers, so that indirectly the State farms are a decided gain to the country, although they are not self-supporting.

In reference to Agricultural Colleges and State farms, the late President of the Board of Agriculture in England, speaking at the opening ceremony of

the Harper-Adams Agricultural College on the needs of agriculture, said that his own conviction was that these agricultural institutions were doing, and would continue to do, a great deal of good. He would like to see many more of them. He had often heard farmers say that the experiments at these places did not pay, and they asked, What was the use of their sons learning that to which no profit accrued? That, at first sight, seemed right; but he did not think it fair to judge State and College farms by a purely financial result. They did not profess to be worked in the way an ordinary farm was worked, but had to be managed so as to be an example to all the farms in the district. It was generally said that the farmer was the only man who had anything to learn by them, but he did not agree with that. There were others associated with the cultivation of the soil who needed educating as much as the farmer.

An American writer says that the school to which a farmer should send his boys, if he desires them to inherit his acres and keep his homestead together, is where his boy can be taught agriculture pure and undefiled in all its branches, and where the teachers have good, sound, practical agricultural common sense. Surely the students at the Queensland Agricultural College and at the State farms are receiving that sound practical agricultural education which will stand them in good stead a few years later. In the United States there are 11,000,000 acres granted to Agricultural Colleges and Experimental Farms, which institutions are attended by 6,000 students.

In conclusion, we repeat that these farms and colleges in our State were established for the purpose of the instruction of all agriculturists, young and old, in the particular culture adapted to different climates, and that object has been attained in a most gratifying manner, as is evidenced by the numerous visits paid by farmers, both singly and in large companies, to each of the State establishments, where they obtain new ideas, study new methods of cultivation, preparation and storage of crops, conservation of fodder, building of silos, &c., and carry away with them a fund of information which not only benefits themselves but their immediate neighbours. In this sense, these institutions are paying fivefold what they cost to keep up.

A NEW HYBRID ORANGE.

An orange which should prove a valuable acquisition to orange-growers is here illustrated. The tree, which is six years old, is a seedling, and it bears a very beautiful firm fruit of large size and bright colour. This fruit, judging from its texture, peculiar seed, and tough inner skin, as well as from the peel, which resembles in appearance and flavour that of the "Beauty of Glen Retreat," appears to be a cross between the Mandarin and the Pomelo. The combined flavour of the two species is very apparent in it. Unlike the mandarin, excepting Beauty of Glen Retreat, the peel adheres very firmly to the flesh, which latter, being itself very firm, should easily stand long-distance carriage without detriment. The tree was raised by Mr. J. A. Beal, Chief Accountant in the Lands Department, at his residence, "Matavi," Corinda, and, as stated, is now six years old and bearing well and later than other varieties. The fruit here shown measures 11 inches in circumference, with a depth of $2\frac{3}{4}$ inches. The foliage of the tree, it may be mentioned, is the same as that of the mandarin. Mr. Beal, some time ago, brought to this office the second largest sunflower ever known to be grown in Queensland. He has named the orange after his own home—"Beauty of Matavi."



"BEAUTY OF MATAVI," HYBRID ORANGE.

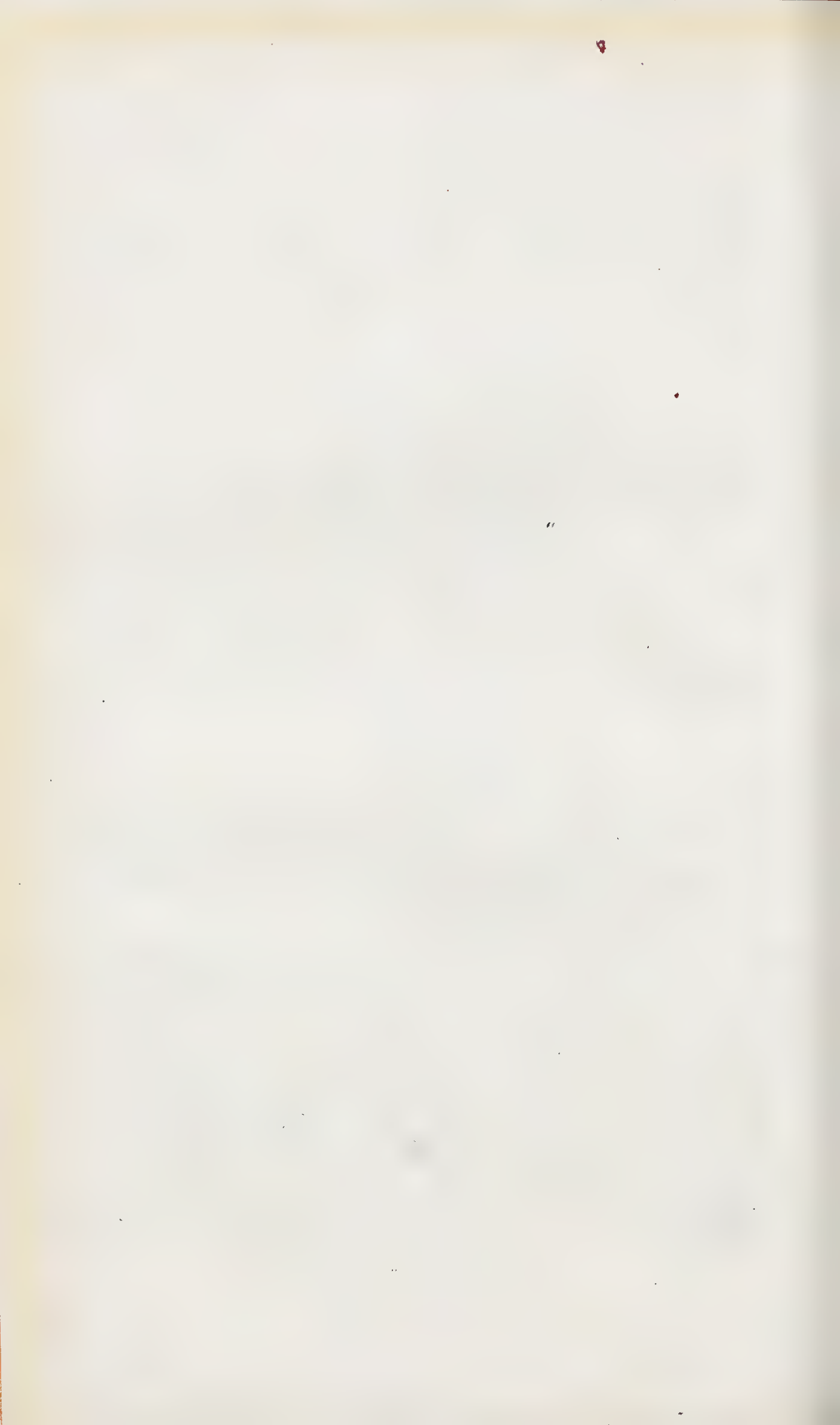
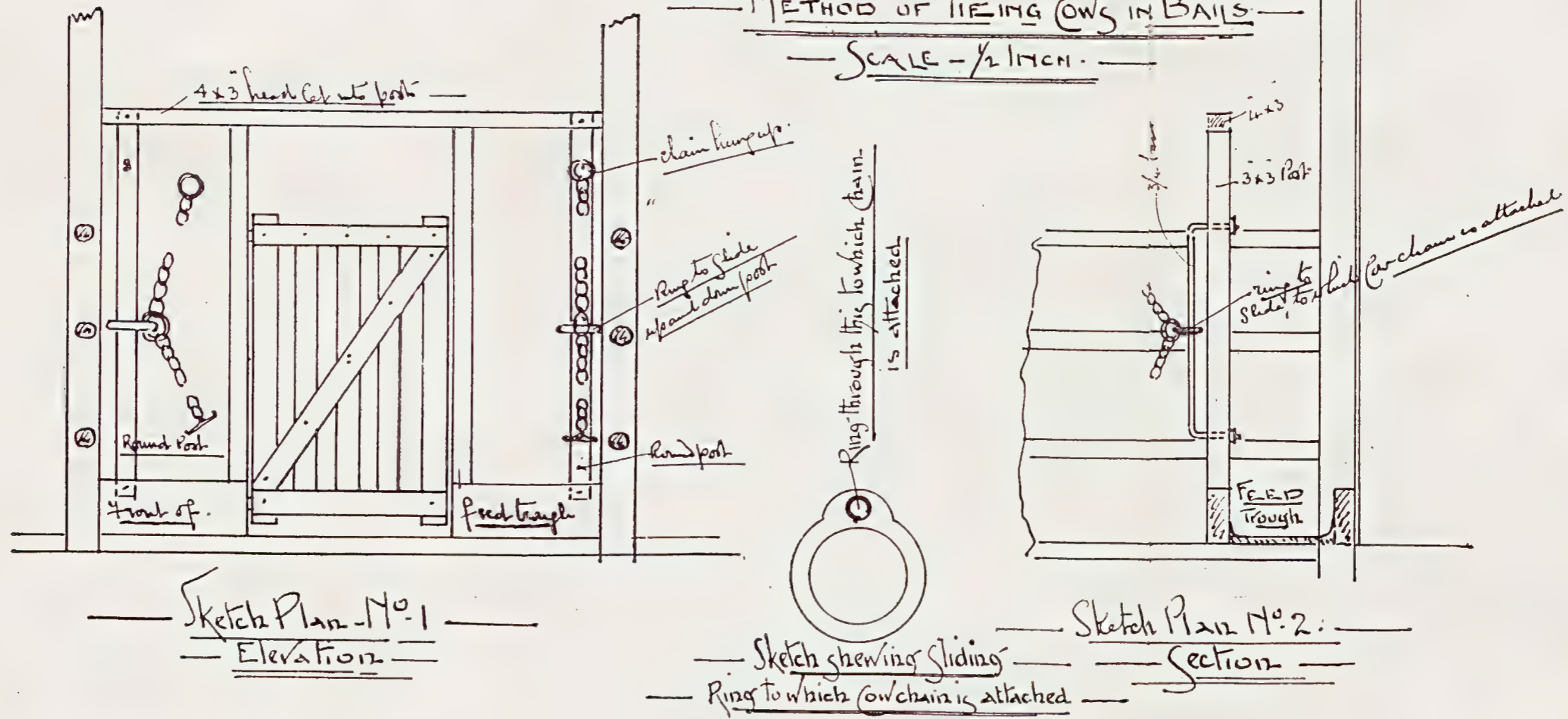

Plate XIII.

— SKETCH PLAN FOR COW BAILS — SHWING —
 — METHOD OF TIEING COWS IN BAILS —
 — SCALE — 1/2 INCH. —



— Sketch Plan No. 1 —
 — Elevation —

— Sketch showing sliding —
 — Ring to which cow chain is attached —

— Sketch Plan No. 2 —
 — Section —

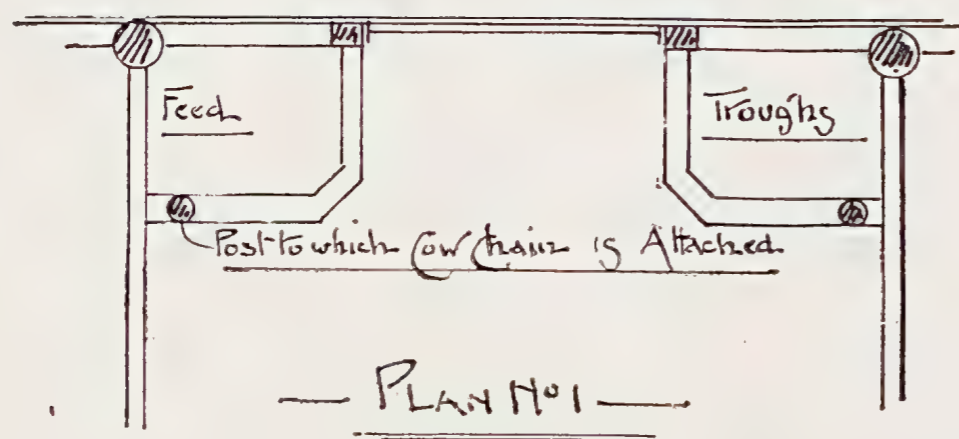

— PLAN No. 1 —

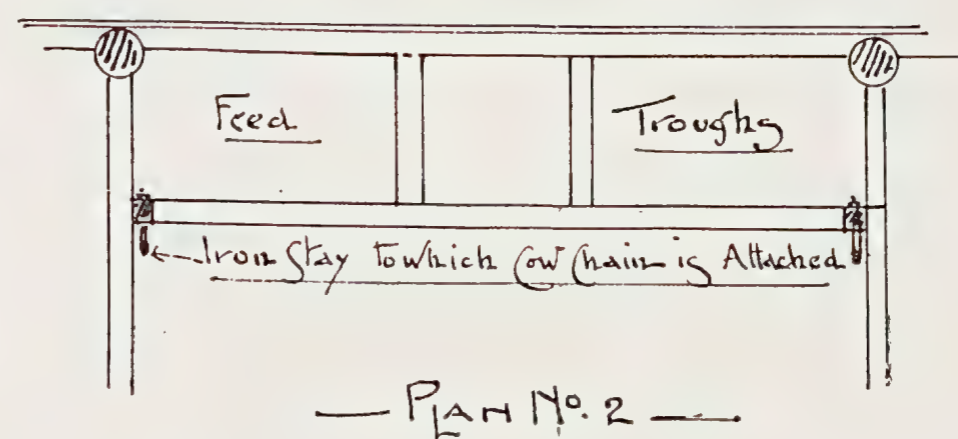

— PLAN No. 2 —

DEVICE FOR TYING UP COWS IN BAILS.

Dairying.

THE DAIRY HERD, QUEENSLAND AGRICULTURAL COLLEGE, GATTON.

RECORD OF COWS FOR MONTH OF JUNE, 1908.

| Number. | Cow's Name. | Breed. | Date of Calving. | Total Milk. | Average Test, Per cent. | Commercial Butter. | Remarks. |
|---------|------------------|-------------------|------------------|-------------|-------------------------|--------------------|------------------|
| | | | | Lb. | | Lb. | |
| 1 | Peewee ... | Holstein-Sh'rth'm | 20 May, 1908 | 1,072 | 3.8 | 45.62 | |
| 2 | Hetty ... | Ayrshire-Sh'rth'n | 26 Mar. " | 788 | 4.7 | 41.48 | |
| 3 | Sue ... | " " " | 25 May " | 886 | 4.0 | 39.69 | |
| 4 | Grace ... | Shorthorn ... | 30 May " | 1,020 | 3.4 | 38.84 | |
| 5 | Rhoda ... | Grade Shorthorn | 30 Mar. " | 904 | 3.8 | 38.47 | |
| 6 | Winnie ... | " " " | 15 April " | 895 | 3.7 | 37.08 | |
| 7 | Carrie ... | Jersey ... | 4 April " | 793 | 3.9 | 34.64 | |
| 8 | Nettle ... | Shorthorn ... | 14 May " | 777 | 3.6 | 31.32 | |
| 9 | Nancy ... | " " " | 7 May " | 702 | 3.8 | 29.87 | With first calf. |
| 10 | Glen ... | " " " | 10 Feb. " | 604 | 4.4 | 29.76 | |
| 11 | Cocoa ... | Jersey ... | 20 Nov., 1907 | 577 | 4.6 | 29.73 | |
| 12 | Orange ... | Grade-Guernsey | 5 Oct. " | 311 | 7.6 | 26.47 | |
| 13 | Beauty ... | Ayrshire ... | 21 Dec. " | 595 | 3.8 | 25.32 | |
| 14 | College Lass ... | " " " | 1 Sept. " | 476 | 4.7 | 25.05 | |
| 15 | Dansel ... | Holstein ... | 19 Feb., 1908 | 649 | 3.4 | 24.71 | |
| 16 | Nellie II. ... | S. Coast Sh'rth'm | 20 Dec., 1907 | 445 | 4.2 | 20.95 | |
| 17 | Ivy ... | Jersey ... | 5 Feb., 1908 | 370 | 5.0 | 20.72 | |
| 18 | Daisy ... | Holstein ... | " " " | 535 | 3.4 | 20.35 | |
| 19 | Mona ... | Grade-Holstein | 26 Oct., 1907 | 498 | 3.6 | 20.07 | |
| 20 | Lily ... | Ayrshire ... | 2 May, 1908 | 615 | 3.2 | 20.04 | |
| 21 | Lucy II. ... | Shorthorn ... | 1 May " | 433 | 3.9 | 18.91 | |
| 22 | Honeycomb ... | " " " | 23 Aug., 1907 | 289 | 5.7 | 18.44 | |
| 23 | Lark ... | Ayrshire ... | 6 June, 1908 | 429 | 3.6 | 17.29 | With first calf. |
| 24 | Lady Ring... | Guernsey ... | " " " | 245 | 6.2 | 17.01 | |

DEVICE FOR TYING COWS UP IN BAILS.

In the matter of bails and gates for the easiest and most effective methods of dealing with cows in the milking-shed, man hath sought out many inventions and ingenious contrivances, several of which have been described and illustrated in former issues of this Journal. Yet another has been described and sketched by Mr. A. Morry, Surveyor to the Department of Agriculture and Stock. The accompanying illustration shows a very useful method for tying up cows (not bailing up) during the night:—

An iron ring is made to slide on a post, as shown in Sketch No. 1. To this a cow-chain is attached, which enables the animal to stand or lie down at will without discomfort. In Sketch No. 2 the arrangement is slightly altered, an iron stay being bolted through the post, to which the sliding ring and cow-chain are attached. It will also be noted, by reference to the sketch plans, that the feeding troughs are placed low, so that they do not interfere with the cattle's movements in lying down or rising.

The Orchard.

THE "GOOTEE" METHOD OF PROPAGATION.

Mr. H. F. Macmillan, in the "Ceylon Tropical Agriculturist," on this subject, writes:—

"The gootee mode of propagating plants has been practised in India from early times. It is adopted in the case of trees which are difficult to raise by layering, or which seldom set seed, and also as a means of increasing any tree of special merit, or part of a tree (as a sport) exhibiting a variation which it is desirable to perpetuate. When other methods of propagation fail, the gootee is resorted to, and, if carefully carried out, it is usually successful. It is of special value in propagating fruit trees, for not only are the plants thus obtained true to kind, but they also come into bearing much earlier than plants raised from seed. The same is true of flowering trees, shrubs, climbers, &c., and for such as do not, from some cause or another produce seed, propagation by gootee is the best means of multiplying them.

"To proceed with the gootee, select a firm healthy branch, with well-ripened wood, immediately under a leaf-bud or "node"; take off a small ring of bark, about 1 inch wide. To this apply a ball of clayey soil, holding it securely together with coir fibre, tow, or moss, and bandaging all firmly round the branch. A little above this hang a pot or chatty; through the hole in the bottom of the latter draw from within a piece of rope; a knot tied on the end of the rope should fit tightly against the hole of the vessel above. The rope, thus secured by its knotted end within the pot, is carried on at full stretch and coiled round the gootee. By this means the water, with which the pot is kept supplied, oozes slowly out, trickles down the rope and along the coil, and so distributes itself over the whole gootee. In from three to four months young roots should be seen protruding through the gootee, when the branch may be cut from the parent tree, and planted where it is intended for it to remain. The operation should be carried out in the wet weather, commencing when active growth in the tree begins."

[A similar method of propagation has long been carried out in Queensland, but the operation is well worth drawing attention to.—Ed. "Q.A.J."]

PRINCIPLES OF PRUNING.

PEACHES AND NECTARINES.

"No pruning is bad, but bad pruning is worse, while 'good pruning is manure.' There is no way to do good pruning but to do it with a thorough understanding of its object. The fundamental facts in pruning are these: The tendency of the tree is to produce more buds than ever grow into branches; more branches than can produce good fruit; more fruit spurs than bear; more leaves than can find proper exposure to light; more flowers than set fruit, and more fruit than can be developed according to the standard of size and quality desired by the grower. 'Man's shrewdness consists not in following Nature, but her hints, and, going further, intensifying natural processes for quick and magnified results.'"

The fruit of the peach and nectarine is principally produced from one-year-old wood, but also spurs.

That in continuation of a branch is termed an extension; that issuing from the side of a branch is called a bearing shoot.

A bearing shoot (M) is usually best furnished with blossom buds on 8 to 12 inches of the first made and ripest growth, and becomes attenuated towards its extremity. This part is worthless for the production of fruit, and, therefore, must be shortened to a growth bud. On thoroughly ripened wood the shoot (M) is pruned to 12 inches, but a wood bud is left at its extremity, and another at its base.

Plate XIV.



THE "GOOTEE" METHOD OF PROPAGATION.

SUMMER PRUNING.

The bearing branch (P) is shown at the disbudding stage. This important operation is generally performed when the fruit is set. The shoots marked (t) are rubbed off by degrees so as not to cause a check, but one at the extremity (u) is retained to attract the sap to the fruit, and is pinched to three leaves, not counting the two small basal leaves; another shoot (v) is reserved at the base of the bearing branch, which makes a sturdy growth for bearing the following year. Directly the best set fruits are taking the lead in swelling, remove the smaller and ill-placed (w), and when those retained (x, y) are the size of small marbles displace all (x) but two (y) of the best, if for very choice fruit, situated on the front or upper side of the branch for ripening.

Further summer manipulation is shown in (Q). The bearing branch growth, after being stopped at (a), pushes laterals (c), from which, after pinching, sub-laterals (d) proceed, and are stopped at every joint as made. All other growths from the bearing branch are suppressed, and when the fruit is gathered the branch is cut out at its base (the bar). The successional bearing shoot is trained-in, but when vigorous and certain to encroach on other growths it must be stopped about 14 inches from its base (b), subsequent growths (c) being stopped at one joint of growth, as shown, by nipping off the point (e). Other laterals may push as at (f), but are more clearly shown in (R), stopped at (g), and if the shoots incline to grossness the leaves may be half shortened (bars); this assists the formation of blossom buds in the axils of the leaves (h), the point of winter pruning.

Under judicious summer management very little pruning is required in winter, and the figure with references to (S) show all that is required. The main thing is to avoid overcrowding, which is ruinous to the trees.

In pruning full-sized or old trees, it is desirable to remove the weak, bare, and misplaced branches, and train-in new and better wood.

DISBUDDING.

Its object is to encourage the enlargement of the fruit, and make provision for the succeeding year's crop by the removal of all superfluous shoots at an early stage. Over-crowding must also be prevented by pinching refractory laterals and unruly growths, so that the wood and fruit will receive the needful light and air to ripen them.

THINNING THE FRUIT.

More fruit than it is advisable to allow to remain generally set on peach and nectarine trees. Thinning should commence when the best fruits approach the size of marbles, and finally, for stoning, when the size of pickling walnuts. These operations should be effected gradually, leaving the fruits thinner on the weaker parts of the tree, and more numerous on the stronger, always reserving those for the crop on the front or upper side of the branches. One fruit to a square foot of the surface covered by the tree is enough to leave for securing the finest specimens. Habits of bearing must have due weight with growers in thinning the different varieties of peaches and nectarines. The health and management of the trees also influence the crop materially. A vigorous tree will not be distressed by one-third more fruits than one of medium strength, or twice as many as a weakly tree. Two fruits to a square foot form a maximum crop of large peaches or nectarines, and more than three fruits of the medium-sized kinds to a superficial foot of surface ought not to be exceeded on healthy, well-supported trees to secure fruit of full size and high quality. Over-cropping exhausts the trees quickly; therefore the cultivator must exercise judgment in thinning the fruit, acting in strict accordance with each tree's manifest condition. In removing the fruit it is necessary to give it a twist and press it in the opposite direction, to avoid tearing the bark, as would be the case if it were pulled off towards the base of the branch.—“Fruit World.”



PROPER AND IMPROPER PRUNING BUDS—DISBUDDING AND THINNING—WINTER AND SUMMER PRUNING.

References:—Proper pruning buds: (F) wood buds, (G) double buds—(p) wood bud, (q) blossom bud. (H) triple bud—(r) wood bud, (s) blossom buds. Improper pruning buds: (J) single blossom bud. (K) double blossom buds, (L) triple blossom buds. (M) bearing shoot shortened. (P) bearing branch after the fruit is set—(l) disbudded shoots, (u) growth to attract the sap to the fruit, pinched, (v) successional bearing shoot, (w) fruits removed at the first thinning, (x) fruits removed at the second thinning, (y) fruits left for the crop. (Q) bearing branch and successional bearing shoot, showing—(z) fruits stoned and leaves drawn aside, (a) shoot above the fruit, pinched, (b) point of stopping the successional bearing shoot, (c) laterals pinched, (d) sublaterals stopped, (e) part to be removed at pinching, (f) lateral on the successional bearing shoot, stopped. (R) lateral from extension—(g) point of pinching, (h) point of winter pruning. (S) winter pruning, showing—(i) point of removing the bearing branch when the fruit is gathered, (j) point of shortening the successional bearing shoot, (k) point of cutting off lateral, (l) proper position for the bearing branches, (m) right place for training the successional bearing shoots, (n) latent basal buds, (c) taking second successional shoot from the base of a bearing branch—a bad practice.

A FEW HINTS ON STRAWBERRY-GROWING.

By WILLIAM FRENCH.

The strawberry belongs to a genus of low perennial stemless herbs, with runners and leaves divided into three leaflets; calyx open and flat, petals five, white; stamens ten to twenty, sometimes more; pistils numerous, crowded upon a cone-like head in the centre of the flower; seeds naked on the surface of an enlarged pulpy receptacle called the fruit.

The strawberry belongs to the great rose family, and the name of the genus is *Fragaria*—from the Latin, *fraga*, its ancient name.

Fragaria vesca is the wild strawberry of Europe; *Fragaria californica* is found growing on the mountains of California; and another variety, *Fragaria chiliensis*, is also found growing wild in Upper India, and is also found wild in Germany.

Therefore, by cross-breeding and fertilisation, those wild weeds, as you might call them, have been raised in thousands of varieties, and to-day the cultivated strawberries rank as one of the leading first-class fruits of the day, and I believe they can still be greatly improved in size, flavour, and productiveness, by which, instead of giving us a harvest of six months' picking, they can be brought to fruit for eight or nine months. Taking into consideration the small plants and the amount of fruit they produce, I consider them a marvel, but "much always wants more." How the name of strawberry came to be applied to this fruit is unknown. Some say it was because children used to string them upon straws to sell; others believe it arose from the practice of placing straw around the plants to keep the fruit clean. But there is nothing conclusive on this point. The strawberry does not appear to have been cultivated by the ancients or even by the Romans, and it is only within this last hundred years that there has been any improvement in the varieties under cultivation.

FIELD CULTURE.

SOIL AND PREPARATION.

In my opinion, the main point to be observed is to secure a depth of soil with good drainage and plenty of nutriment for the plants. If planting in new soil, give nothing less than two ploughings, say 4 inches deep. After the first ploughing allow the land to lie exposed to all weathers for a month or two, after which give a good harrowing across the furrows, and after a few days run the roller over to break all lumps, the reverse way of harrowing. Then give a second ploughing, nothing less than 8 or 9 inches, or deeper, if possible. Better still, run the subsoiler after the plough, as I find it to be of great advantage in allowing the roots to penetrate deeper, and also in retaining moisture against dry spells.

Let it lie for a week or two exposed to the atmosphere. Then, after a shower, roll again, and, if required, harrow again, to make sure that the soil is properly pulverised, as this is, I consider, the foundation of success, and therefore a most important point is to have the soil under proper tilth, or, as the saying is, to have the soil like an ash-heap, so that the roots of the plants can lay hold of the soil at once after they are planted. If the soil is left rough and lumpy, the roots cannot get to work. Therefore, after a few days of wind and sun the plants are parched up, and hence the aggravating work of filling up misses, which I consider is very disheartening and a serious loss of time. New soil is greatly improved by growing a crop of fodder, say oats, barley or cow-pea, which, if not required for feed, can be ploughed in as a green manure, by which means you will find your soil will work as mellow again.

SMALL GARDEN CULTURE.

Trench the beds about 5 feet wide and 18 inches deep. If the subsoil is of a clayey nature, leave it at the bottom of the trench, but if fairly good mix it with the top spit along with plenty of vegetable matter, rubbish, &c. Let

it lie for a month or more to mellow. Then fork and pulverise well until the soil is free from lumps. Now let it rest for a week or two. If farmyard manure is procurable, scatter it on the surface 2 or 3 inches thick, and fork it in well, so as to mix the soil and manure thoroughly. In a fortnight it will be ready for planting. Plant four rows in a bed. By having narrow beds, trampling upon the planted soil is avoided. Set the plants about 1 foot apart in the rows. Planting close in the garden necessitates replanting every year, whereas in field culture more room is given. Several varieties can stand for two years giving good results, by keeping the soil between the rows constantly cultivated, which I maintain must be done if good results are to be obtained.

PREPARING FOR PLANTING IN FIELD.

My plan is to draw out drills with the plough as deep as possible about 2 feet 6 inches apart, and put the manure in the trench. If artificial manure is used, draw a long-toothed rake along the furrow to mix the manure and soil well together. This is not necessary with farmyard manure; merely run the Planet-Junior between the drills to cover in the manure, and leave it as level as possible. If this latter point is not attended to, you will find that after heavy rain the plants in the hollows will be buried with their crowns too deep, and consequently they will be weeks before they make a start into growth.

MANURES.

The strawberry is a plant that will not refuse a fair amount of manure, providing it is presented in a proper form. My experience is that the plants make a start into growth much quicker, and are well-established before the winter, where I use the farmyard manure, but I am sorry to say it is too scarce. The principal manure I use to plant on is bonedust, at the rate of about 10 cwt. to the acre. I find that by putting the manure well down below the surface it greatly encourages the roots to strike downwards, and the lower they get down the more moisture they obtain, and are thus not affected by the heat and drought half so much as when the roots are encouraged close to the surface. After the first crop is gathered I mix my own fertilisers, consisting of superphosphate, sulphate of potash, and sulphate of ammonia, in the following proportions:—Two parts superphosphate, 2 parts sulphate of potash, and 1 part of sulphate of ammonia. Make sure to break all lumps so as to have it well mixed, as this is an important part. I have a small hand plough, which I run along the rows, and it makes a furrow about 2 inches deep. Sow the mixture in the furrow, and by running the plough the reverse way it covers over the manure.

PLANTING THE STRAWBERRY.

While it is impossible to fix a hard-and-fast time to transplant, as the seasons differ so much, I shall have to leave it to the grower's own judgment. If your ground is in good order and the weather showery, you can start on the 1st of March. I also prefer young runners. Some growers say they get the best results from old crowns split up, but that is not the case with me. I plant about 2 feet 6 inches between the rows and from 1 foot to 18 inches in the rows, to allow the horse and scuffler to go between the rows, so as to keep the soil always open, which I consider of great importance. In transplanting, some recommend shortening the roots by one-half. I consider this practice all right in the cooler countries, where the ground is, practically speaking, always moist and cold below; it is also a good practice in cases where the roots are allowed to get dry or are injured in any way. In such cases a clean cut would, in my opinion, be beneficial. My way of planting is to allow the roots to hang down straight in the hole, the deeper the better on account of coolness and moisture, provided the crown is not smothered. Some cultivators use a dibble for planting, making a round hole, into which the roots are thrust in clumps. Others just scratch a handful of soil off the surface and plaster it back on the

roots, the latter lying in a horizontal position, instead of hanging perpendicularly in the hole. Plants might live under such treatment, providing we had showers every day, but careful planting with a trowel is far the better way.

VARIETIES THAT DO BEST WITH ME.

Aurie.—This was planted at the end of February of this year, and we were picking fruit off them on 23rd April. The berry is large, well-flavoured, and of fine colour. It carries well, and is good for box and factory. No disease has appeared on it.

Glenfield Beauty.—Of good robust habit; good both for box and factory, providing they are allowed to ripen properly. They commence to ripen in June, are very prolific, and prefer heat and moisture.

Trollope's Victoria.—An old favourite, rather late compared with the later and locally raised varieties, producing good box fruit; useful also for the factory. My experience is that it is shy in bearing in a moist season. If anyone is planting this variety, I should advise them to keep it on the high ground.

Annetta.—Previously known under the name of "Butt's Seedling." It is rather erratic in bearing. During some seasons it does splendidly, at others the reverse. Last year I did well from one patch, whereas another lot gave poor returns. This year I have 5,000 or 6,000 looking splendid and showing good fruit.

Marguerite.—Good for the first of the season, but after giving a good first crop it cannot be depended upon for the remainder of the season.

Federator.—This variety is like the *Glenfield Beauty*. It produces a splendid crop in a good moist season, but stands a heat wave very badly. It prefers a low, moist position.

Pink's Prolific.—Good for a private garden, but too small and late for a large area.

Noble.—Good for an early variety, producing a splendid large and good-coloured berry, but a short cropper.

With several others, including "Made to Order," one Mr. Pink crossed between *Aurie* and *Trollope's Victoria*. At the time of planting, the weather was all that could be desired. A good cropper, also free from disease.

Usher's Special, also *Phenomenal*.—The last two varieties I have not had in my possession long enough to say much about, but they are promising. Also one imported from America is of splendid colour, flavour, of good size, with splendid promise.

PROFITS OF STRAWBERRY CULTIVATION.

Persons who have had no experience in raising strawberries for market are desirous of ascertaining in advance the prospects of profits on investments. Unfortunately for the would-be investor, results depend greatly upon circumstances, such as markets within reasonable distance, plenty of labour at moderate prices when needed, land at reasonable prices, also fertilisers, and favourable season. The greatest profit made in the cultivation of the strawberry is by small growers within a moderate distance of the towns, who have children to assist in gathering the fruit when needed. An acre of strawberries under high cultivation, with the fruit gathered and marketed in the very best condition, will often yield more clear profit to the grower than 10 acres under opposite conditions.

MULCHING.

Forest oak leaf makes a splendid mulch when procurable. If not, half-decomposed leaves would keep the fruit clean from grit, and also do a great deal of good in furnishing the plant with humus, which is a favourite of the strawberry.

Referring to planting old crowns, I have been making a further test this year with the *Marguerite* and *Trollope's Victoria*. A very good variety for

colour. Then they took about a month longer to establish themselves than the young runners. Therefore, if the weather is dry, they are very unsatisfactory. Yet they came into fruiting first with a very light crop.

A FEW REMARKS ON SMALL FRUITS.

I consider there ought to be something done regarding the fixing of prices. For instance, for, say, jam berries, prices should be a little more regular than at the present time, so that growers and manufacturers could work with more confidence together, instead of carrying on this cut-throat competition, the outcome of which is certain to grind the hard-working tiller of the soil down, until eventually he is forced to give up growing the small fruits and take to growing large fruits, where less labour is required for cultivation and marketing. I consider this evil could be overcome to a great extent by a conference between manufacturers and growers, considering the demand for this fruit is about 400 per cent. higher than the supply, taking a manufacturer's own statement for it, and also the scarcity of same on our local markets.

STRAWBERRY INSECTS AND DISEASES.

Crown Borer (*Tyloderma fragariae*, Riley), White Grub.—One-fifth of an inch long, boring into the crown of the plant in midsummer. The mature insect is a curculio or weevil. In reference to this pest, to the best of my belief, Australia is free from it.

Remedy.—Burn over the field after the fruit is picked. If this does not destroy the insects, dig up the plants and burn them.

Strawberry Leaf-blight, Rust, or Sun-burn (*Sphaerella fragariae*, Sacc., including *Ramularia*).—Small purple or red spots appearing on the leaves. These eventually become larger, making the leaf appear blotched. Most serious after the first crop of fruit is picked.

Remedies.—Spray with Bordeaux mixture at intervals of two weeks, as soon as the fruit is picked. The leaves are easily destroyed, without injury to the plants, by quickly burning off a thin layer of straw, which is spread over the patch after the fruit is off.

I am pleased to say that we have several varieties, practically speaking, free of this disease. This includes also our locally-raised ones, which I have already made mention of.

The strawberry, as indeed all plants, takes certain substances from the soil—viz., "manurial ingredients." These may be defined as those substances from which the plant derives its supplies of nitrogen, phosphoric acid, and potash. Now, it must be remembered that all plants require adequate supplies of these three manurial ingredients, but different plants require them in different proportions.

For example, sugar cane requires a great deal of potash, relatively little phosphoric acid, and much nitrogen.

An acre of strawberries will contain—375 lb. potash, 222 lb. nitrogen, 83 lb. phosphoric acid.

In 7 tons of farmyard manure there will be an average of—74 lb. potash, 77 lb. nitrogen, 57 lb. phosphoric acid.

Compare these figures, and it would be seen that farmyard manure would be a badly-balanced fertiliser for strawberries, because in order to supply sufficient potash considerable excess of nitrogen would have to be supplied, and a very large excess of phosphoric acid; so that it would appear as if a much more economical manurial dressing could be prepared if, instead of farmyard manure alone, a combination of farmyard manure and artificial be used. But where farmyard manure can be produced on the farm, then, for a first crop, it is preferable to all other manure.

For strawberries, when farmyard manure cannot be obtained, a good dressing consists of—3 cwt. bone-dust, 3 cwt. superphosphate, 1 cwt. dried blood, $\frac{1}{2}$ -cwt. sulphate of ammonia, 2 cwt. sulphate of potash per acre, or in these proportions.

Horticulture

FLOWER GARDENING, No. 7.

By THE EDITOR.

PLANTS SUITABLE FOR OUTDOOR CULTURE.

PENTSTEMON.

Amongst popular hardy plants, few surpass pentstemons for their usefulness and ornamental character in the mixed border or rock-garden, or for planting in beds by themselves. Many of the species are very attractive, and are indispensable in the choicest collection of herbaceous plants, and a selection of the numerous improved varieties is equally valuable for garden decoration and for cut flowers. They bloom very freely for several months in the year, and are exceedingly hardy.

Pentstemons are very varied in colour. They may be propagated either from seeds or cuttings, the latter method being adopted if it is required to perpetuate species or named varieties. Seeds should be sown in boxes of light soil in autumn or spring, and, as soon as they are large enough to handle, pot them off singly, and leave them until they are well established, and then plant them out in borders in the open.

Notwithstanding their hardiness, they are very susceptible to wet and frost, especially to the former. It is, therefore, very important that the land should be well drained. For enriching the soil, the best compost is leaf mould, mixed with decayed manure and some sandy loam. A good mulch of 2 or 3 inches of stable manure applied in the spring will also greatly stimulate the growth of the plants. Through the summer, the plants will require plenty of water, but very little in winter. Old plants, kept outside, should be covered in autumn with ashes, or they may be divided and replanted in the same or different borders.

Some years ago, the National Agricultural and Industrial Association of Queensland offered two medals to the owners of the best flower gardens in the neighbourhood of Brisbane, the gardens to have been planted and kept up by the owner without any outside help. I happened at the time to have a splendid assortment of pentstemons in my garden, so I entered it for competition, and had the satisfaction to gain one of the medals. I was told afterwards that it was the pentstemons which contributed mostly to my success.

VARIETIES WORTH PLANTING.

P. Murrayanus—Scarlet; *P. Coboeca*—White and blue; *P. Irvine's* new Hybrid—Various colours, flowers extra large; *Alba*—Pure white; *Alexander Pfau*m—Deep lake, white throat; *White Beauty*—Pure ivory white, tinted rose; *Clara* and *Clio*—White bordered with purple; *Emblem*—Rosy scarlet, white throat; *Perle*—Pearl white; *Neron*—Purple, white throat; *Georges Sand*—Veined white lips, tube bright purple; *Cardinal*—Brilliant scarlet, large flower, and many other beautiful varieties which are catalogued by nurserymen.

CLIANTHUS AND NOVELTIES.

Regarding *Clianthus*, or *Glory Pea*, I will quote from the *Cyclopedia of Horticulture*, and possibly this information may help to make a success in growing it.

Clianthus Dampieri is anything but easy to grow in the latitude of Brisbane. Red spider is its greatest enemy, but too much moisture in the soil, followed by hot sun, is equally fatal to it. In a sandy soil when the seeds are sown early in spring, the plants during ordinary summers make a very fine display. The plants will not bear transplanting. Even when they are grown in pots, it is a risky piece of work to shift from small pots into larger ones.

SWEET PEAS.

As a hardy annual, there is nothing finer than the sweet pea, and where its cultivation is properly carried out the flowering season may be very much prolonged.

The soil for this beautiful plant must be very rich, and, if it is not naturally so, it must be well fertilised by working in thoroughly rotten stable manure in the summer previous to sowing the seed. The soil should also be left open to sun and air until the time for sowing the seeds comes round, which will be from February to March and even on to May and June; but, in very cold districts, it is better to defer the sowing until spring. By sowing in autumn, however, strong plants will be produced before the winter, which will resist any moderate winter cold. The seed may be sown, either in rows some 6 or 8 feet apart, to form a hedge, or in colour groups, using a large inverted pot, and sowing the seed round the impression made by the rim, keeping the seed, in the latter case, a good distance apart. As soon as the seedlings are an inch or two above the soil, they should be firmly staked, using sticks of dead brushwood for the vines to scramble over. It is always advisable to use a light mulching, as this prevents the moisture in the soil from evaporating, should very dry weather be experienced in late spring. Rotted leaf mould and well-rotted horse manure are as good as anything. This mulching will save a good deal of labour in the matter of watering, which, in very dry weather, does more harm than good by causing the soil to bake and harden. The after treatment of the plants merely consists in keeping the flowers picked to prevent the formation of seed, and by this means the flowering season is much prolonged. When they begin to show signs of exhaustion, go over them with the shears and top them. This will induce them to make new growths, from which flowers will continue to be produced for some time. In addition to the annual, there is the hardly less beautiful perennial or Everlasting Sweet Pea, which is most effective when planted as a hedge. J. Cronin, Principal of the School of Horticulture, Burnley, Victoria, writing on the cultivation of the sweet pea, says:—"The perennial kinds are propagated from seeds, divisions, or cuttings of the young shoots in spring under a bell glass. Seeds should be sown in pans or boxes early in summer, and may be transplanted in the following spring. *Lathyrus latifolius* and its varieties do not produce seeds freely, so propagation from divisions and cuttings is resorted to as a certain means of increase. Cuttings when rooted may be grown in pots for the first season, or may be planted at once where it is intended they should grow. They produce their growth during spring, bloom during summer, and die down to the ground during autumn. They are suitable for clumps in the gardens, and for covering a trellis or breakwind. A deeply-worked well-drained loam is suitable, and they may remain undisturbed for several years. *Lathyrus pubescens* is raised from cuttings or seeds. Plants from pots may be set out at any time during the season of active growth. They thrive best in a stiff loamy soil, and require a position on an open trellis, where the shoots should be trained as growths develop. Many of the older varieties of sweet peas are unworthy of culture in comparison with new varieties of the same colour, and may be discarded with advantage, as the seeds of the better varieties are offered at cheap rates. A good collection should include Helen Lewis, Gladys Unwin, Mrs. Alfred Watkins, Nora Unwin, Frank Dolby, Queen Alexandra, Evelyn Byatt, Romolo, Piazzani, Black Michael, Helen Pierce, Henry Eckford, E. J. Castle, Countess Spencer, Mrs. Walter Wright, Miss Willimott, Black Knight, John Ingman, Dorothy Eckford, Hon. E. Kenyon, Navy Blue, and Earliest of All, the latter being the earliest sweet pea. Perennial kinds:—*Lathyrus latifolius*, and the white variety albus, Pink Beauty, splendens, grandiflora, and pubescens."

PHLOX.

In this genus, there are some twenty-seven species, some tall, some dwarf, some creeping, others erect, some annual, and some perennial. The perennial species and varieties of phlox are some of the best and most popular of garden

plants. They are all very easily cultivated, and are practically within the reach of everybody. The dwarf-creeping species are very suitable for the rockery or front line of a mixed border. None of the dwarf species seed freely; they are propagated chiefly by means of cuttings or divisions. The perennial (*decussata*) is quite a different section, producing spikes of flowers some 2 feet in height; it does not, however, usually flower the first season from seed. For increasing new or scarce varieties, cuttings may be made from pieces of root. These may be cut into short lengths, and treated somewhat like seeds. Propagating by division simply consists in lifting the plants in early spring, cutting them at the base into small pieces, and replanting. These tall-growing perennials succeed best in rather heavy soil, and where it is of good depth; they will, however, thrive fairly well in any good border or bed. A thick top-dressing of manure in summer is of great help, both by preventing evaporation and affording nutriment. If the weather is dry, a heavy drenching of water occasionally is also recommended, as it tends to prolong the flowering season. The plants are very attractive in beds by themselves or in mixed borders along with other perennials. They are also well adapted for culture in pots, if provided with a rich soil, and grown in a cool, slightly shaded frame, through the summer.

Among the phloxes, the *Phlox Drummondii* must take a first place, as it has everything to recommend it. If sown in the autumn, it will flower in the winter, and continue to flower for several months. A later sowing in early spring will give plants which will bloom throughout the summer, and, if planted in beds, will produce a most dazzling effect, as the plants are simply covered with flowers which often entirely hide the foliage. Plants which have been flowering during the summer are sure to seed and produce a host of seedlings, which can be planted out when the weather is favourable.

The seeds should be planted in pans or boxes in spring or autumn, in light, rich soil. As soon as they are large enough to handle, they may be planted out in light, rich soil. Plant the dwarf kinds about 8 inches apart; the others at least 1 foot apart. Mulch and water when the weather is dry, and thin out the weakest shoots when the plants have become large.

SOME GOOD VARIETIES.

Grandiflora alba—Pure white; *Grandiflora*—Dark purple; *Grandiflora*—Scarlet; *Grandiflora stellata splendens*—Pure white, with stellated centre; *P. cuspidata*, *Nana compacta*—Dwarf; Great Gero—A very dwarf variety, flowers of all shades and colours; Semi-double—Very free-flowering, producing semi-double flowers of all shades and colour, and remaining a long time in bloom.

NARCISSUS OR DAFFODILS.

The narcissus thrives well in Southern Queensland, yet these beautiful, sweetly-perfumed flowers are seen in too few gardens. Whilst they require a certain amount of care, they are very easily grown. The chief cause of failure is late planting, irrespective of variety. Some varieties may be planted as late as May or June, without any appreciable falling off in quality or quantity of blossom; while there are others—the *Poeticus* section, for instance—that can hardly be planted too early. The best results with these are obtained by planting in March or perhaps in February. The depth at which narcissi should be planted is important. It will vary with the size of the bulb. A good old English rule is that all narcissi bulbs should be covered with soil, once and a-half their own depth, measuring from the collar of the neck to the actual base.

The best soil for these bulbs is a nice moist sandy loam, but they are not at all particular as to soil, and may be left alone for several years after planting. Some, indeed, like a rather deep and somewhat stiff soil, and, if the position is one partially shaded from hot sunshine in spring, the flowers of some of the species retain their beauty for a much longer period than they would if exposed to all the light and sunshine possible. Narcissi are well

adapted for planting by the sides of creeks and waterholes, and in mixed flower or shrubbery borders. They are also suitable for naturalising, in any quantity, in the grass, by the sides of walks—in fact, in any position where they may be readily seen on their appearance in the spring. Many people transplant the bulbs annually, but this is not at all necessary, nor, indeed, desirable. The foliage should not be cut off when green, but allowed to die naturally, and then be removed.

On no account should the bulbs come in contact with crude manure, or they will assuredly be injured. Where manure is rendered necessary by the poorness of the soil at the time of planting, it should be well rotted, and placed at such a depth that the roots of the bulb do not run into it. Growers should take care that the bulbs rest upon the soil, and are not "hung up." Plenty of water is essential in the growing season, and the flowers are always more beautiful in a moist season than in a dry one. An important matter in growing the narcissus, and one that is but imperfectly understood is "Lifting." Some growers lift their bulbs every year, even before the leaves have matured. This is a fatal mistake. Only certain varieties may be lifted annually, and even these need not be moved. Many may be left for years, until the soil is so exhausted that the plants show decided deterioration. Then the whole batch should be lifted. It is an excellent plan to move the bulbs to an entirely different location, as a change of quarters makes a wonderful change for the better in their recuperative power. All experienced bulb-growers are aware of this, and periodically change the narcissi stock when they have trial grounds in two widely different parts of the country.

Lifting must always be done with care, and the best time for the operation is when the foliage has attained the yellow stage preparatory to decay. Where only just a change of quarters is required, as in the average garden, the bulbs, after lifting, should be carefully dried in a cool, airy shed. As soon as they are properly dry, any offsets large enough may be separated from the parent plants, either by pulling them apart or by cutting. Drying narcissi bulbs indiscriminately is a very bad practice. As a general rule, lift, divide, and plant out at once.

There are some varieties which are best naturalised, because they cannot be persuaded to grow or bloom as border plants. These should be planted in grass plots. The English Lent Lily, the beautiful Pallidus Præcox Scoticus, Spurius, are never so happy as when planted in the meadowlands of the old country. Once a stock of these is planted in the grass they will soon increase by means of seed. When planting bulbs in grassland, they may be dibbled in with a crowbar, or a better plan is to take the grass up and prepare the soil underneath.

SPECIES.

In scientific lists the species and varieties are divided into sections, and these again into groups. The sections are:—HOOP PETTICOAT DAFFODILS, TRUMPET DAFFODILS, CHALICE CROWNED, and POET'S DAFFODILS.

Group I.

Magni-coronatae—This group contains the largest Trumpet Daffodils.

Group II.

Medii-coronati, or Chalice-cupped Daffodils (*Narcissus incomparabilis*).

Group III.

Parvi-coronati (Dolly Cup, or Small Crowned Daffodils).

SOME GOOD VARIETIES.

Magni-coronatae.—Golden spur—Deep soft yellow; early. Henry Irving—Broad, spreading yellow perianth; large yellow trumpet. Emperor—Perianth, deep primrose; trumpet, rich yellow. Bi-colour (of Howorth)—Perianth, white; trumpet, primrose; late. Maximus—Rich, deep golden yellow; perianth elegantly twisted; one of the best. Mrs. Walter Ware—Perianth, white; trumpet, golden; expanded at brim and frilled; one of the

finest bi-colours. William Goldring (The Swan's Neck Daffodil)—Long, snow-white, tapering, and twisted perianth, gracefully drooping over the primrose trumpet; a very elegant daffodil.

Medii-coronati.—Sir Watkin (the Giant Chalice-cupped Daffodil)—Handsome bold flower; perianth, sulphur; cup, yellow, slightly tinged with orange; a good cutting flower. *Narcissus Barrii*, *Narcissus Leedsii*, *Narcissus Nelsonii*.

Parvi-coronati.—(Dolly Cup, or Small Crowned Daffodil)—*Narcissus Burbidgei*. Vanessa—Clear yellow, small, flat cup; free bloomer. *Poeticus* (Pheasant's Eye)—Perianth, pure white; cup, citron. *Poeticus ornatus*—Perianth, pure white, broad and well-formed; cup, margined scarlet. *Poeticus plenus* (Gardenia-flowered)—Double, pure white, highly fragrant.

Double-flowering Narcissi.

Orange Phoenix (Eggs and Bacon)—Beautiful large, double white flowers, with rich, orange scarlet segments in the centre. *Telemionius plenis* (Double Daffodil)—Deep yellow flowers, large and very double.

Single and Double Jonquils.

Odeus (Campernelle Jonquil)—Perianth and cup, rich golden yellow, several flowers on a stem. Jonquilla (Single Jonquil)—Deep yellow. Tenuior (The Silver Jonquil)—Sulphur white, yellow cup.

Polyanthus Narcissus.

(Tazetta, or Bunch-flowered section.)

Double Roman—White, with orange centre. Grand Monarque—White, clear, yellow cup, very large spikes. Dubius or Paper White—Pure white, a good early variety for cut flowers, and valuable for scent-making. Grand Soleil d'Or—Yellow, orange cup.

CHINESE SACRED LILY.

One of the very best species of *Narcissus* is a sub-variety of *N. Tazetta*, known in horticulture as *N. Tazetta, var. orientalis*. It is usually grown in the same way as a hyacinth—in a bottle of water. But it is perfectly at home in the open ground.

A single bulb in a bed, thirteen or fourteen years ago, has never been disturbed, and has had no special care, merely a little fertiliser at long intervals and grass kept away part of the time.

The one bulb has increased to twelve. Seven of these have bloomed this spring, each stem bearing from six to thirteen beautiful white flowers. Looked at from one side, the clusters of blossoms seem to be pure white. But it is not, for the tiny crown in the centre of each bloom is light lemon colour. With better care it would doubtless be more prolific of flowers. Yet all the family are well suited for the gardens of those who have little time or strength to devote to their flower beds, for they will stand neglect better than anything we know of except crinums and roses.

ATTAR OF ROSES.

This delicious perfume, which at one time used to be sold at a guinea a drop, may be obtained as follows:—Gather a quart of rose leaves from fragrant roses after the dew is all off. Do not pick them soon after rain, as they are not so fragrant then. Put a layer of the leaves at the bottom of a wide-mouthed glass bottle, sprinkle with salt, and then cover with a layer of absorbent cotton made wet with pure olive oil, another thick layer of rose leaves, sprinkled with salt, and fill the bottle with alternate layers until the bottle is full. Tie a piece of oil-silk (double) over the top of the bottle; set it where the sun will shine on it all day for two weeks; then uncover, and extract the oil from the cotton and rose leaves. It is superior to much of the perfumes which are sold.

Tropical Industries.

THE CULTIVATION OF RUBBER FOR TROPICAL AUSTRALIA.

By HOWARD NEWPORT, F.R.H.S., Inspector in Tropical Agriculture, Cairns, N.Q.

III.—PARA RUBBER TAPPING.

The operation of harvesting is of all cultural operations the one that naturally invokes the most interest, and in such countries as this, and under conditions where labour is at so comparatively high a premium, the facilities with which the harvest can be gathered in and the product rendered marketable or realisable constitute the basis on which the industry will be judged, and, indeed, on which its very existence is founded.

The natural differences in the processes of harvesting are perhaps more marked between the staples of tropical than of temperate countries. The process by which the marketable product is obtained, in the case of rubber, involves a system of cutting or scoring the bark in some manner so that the resulting exudation (the rubber latex) is caught and subsequently solidified. This is technically known as "tapping," which name, however, does not happily describe the operation.

The obtaining of the harvest in this case is certainly very different from that of most agricultural industries at present under cultivation in this country, but because the ideas may seem new and the principles involved unusual and curious, as well as different to anything yet experienced, the subject need not be put on one side as not being worth consideration.

It is difficult, perhaps, to overcome the idea that insensibly prevails among a section of the farming community that what cannot be handled in bulk does not present the same possibility of profit, and it may have been with some such ideas, or the apparent intricacies of the operation, that led one good old farmer, on learning that the actual amount of "milk" from each individual cut, or even tree, was comparatively little, and certainly not as much in quantity per day as he got from one of his Jerseys or Ayrshires, to somewhat contemptuously designate it "a finicking business any way." It is, perhaps, a pity that rubber cannot be harvested with a pitchfork or shovel for some reasons, though, as previously pointed out, the very fact of its smallness in bulk, per value, is one of its greatest advantages as a cultural industry in this country.

Nor is the process of tapping and the subsequent coagulating so intricate as it may seem at first sight—certainly not more so than the making and marketing of butter and cheese, which, indeed, it somewhat resembles.

As stated in the last article on this subject, the period at which the trees may be tapped for their rubber is a matter of size rather than age, the recognised minimum being a circumference of some 15 or 18 inches 3 feet from the ground, and which size may be attained in four years under specially favourable conditions, five years with attention, cultivation, and care, or six years under normal circumstances and no especial cultivation, in North Queensland. The reason why trees of less size than that mentioned should not be tapped is not because of fear of undue reduction of the vitality of the plant, nor even because little or no latex is obtainable, but rather because it has been found that before a tree attains a certain degree of maturity the latex contains proportionately less caoutchouc and more resinous matter, and the rubber is consequently of poor quality.

I also explained in a previous article that the laticiferous system, consisting of ducts or cells in the bark of the rubber-trees, ran nearly vertically, and the

cuts necessary to enable these ducts to be emptied, or as nearly emptied as possible, must consequently be horizontal. Not entirely horizontal either, for then the latex would run over the bark and largely be lost, or at least most difficult to collect, but on a slope, to enable the latex to be caught and collected in a cup or receptacle at one end.

The latex, as such, requires no further description than that given in my first article. A chemical analysis would be of no practical use in this series of papers, and, indeed, an effort is made to avoid technicalities, scientific names, and statistics, in order that these may constitute plain, straightforward, and explicit descriptions of the processes and methods the ordinary average farmer must follow in practically working a small plantation.

By the latex is meant the white, sticky, milky secretion in the bark, that exudes more or less slowly on the bark being wounded.

In tapping rubber-trees it is seldom any cutting is done higher on the trunk than a person can conveniently reach. The trunk of a tree from the ground to a height of 6 or 7 feet, therefore, constitutes what is known as the tapping area.

Various experiments have been conducted in connection with the tapping of the trunk and the lower limbs at greater heights, even up to 30 feet, but for many reasons this has been found unsatisfactory, for in the case of the higher trees ladders cannot be handily manipulated and scaffolding is expensive and cumbersome; and, moreover, it is still a very doubtful question whether the annual production is materially increased thereby.

Occasionally, in some cases, the tapping area may be increased and made to include a few more feet of trunk by means of a short sort of stepladder. It is far more satisfactory, however, to obtain, if it can be done, a tapable stem of not more than 8 or 10 feet in height but of extra circumference or thickness. This is a matter that takes us back to the cultivation of the tree, and is an object which can be materially assisted, if not always attained, by the judicious pruning back or topping of the young tree and encouraging it to branch at a reasonable height, instead of allowing it to grow into a long, tall, and thin sapling.

The modern methods of culture, therefore, will tend towards the production of a broad and thick stemmed tree with a correspondingly large tapping area, just as modern methods of tapping have for their object the obtaining of a maximum regular flow of latex, with a minimum amount of damage to the vitality of the tree.

The old processes of tapping wild rubber-trees in any instances obtained certainly a maximum of latex, but it was at the expense of the life of the tree; in some cases the tree was literally cut down first and then tapped. Whereas it is obviously more advantageous to get a lesser quantity, but get it annually for a longer period, by preserving the life of the tree. The old methods, and, indeed, those still in vogue among the natives collecting many kinds of wild rubber, were the most crude, and consisted of nothing more than an irregular and generally sloping wound in the bark inflicted by an axe, cutlass, or knife, and a clay cup, or sometimes nothing more than a leaf, into or on to which the latex was allowed to drip. These gashes were generally much deeper than necessary, and naturally impaired the vitality of the tree. It was very soon found that deep cutting was, to say the least, unnecessary, because the ducts or cells containing the latex were only to be found in the bark itself, and therefore deeper cuts obtained no more of the secretion than shallower ones.

At the same time, such wounds extending through the cambium or vascular system between the bark and the sap wood, did not heal readily, and ultimately tended to kill the tree, while wounds only in the bark healed rapidly, did not affect the vitality of the tree, and could be opened again.

As the method of tapping became more systematised, the cuts were made lighter, but still a fresh cut was made for each tapping. During this period

these generally consisted of one sloping cut 6 to 12 inches in length, or of two at about the same angle, meeting at a point like the letter V, so that the latex from both could be collected in the one receptacle. Below I give an illustration of this.

Subsequently more modern methods improved on this again, and what may be called progressive tapping was inaugurated, consisting of the reopening of the first cut by taking off a thin shaving of bark from the lower side of it. This, of course, meant an immense saving of bark or tapping area. The next step was to save collecting tins or receptacles, or rather reduce the number necessary, and so, instead of the two cuts constituting the "V" method, a number of cuts were connected thus—

giving rise to what is now known as the half and full "herring-bone" methods. (See Plates XV. and XVII.) After this came the spiral methods (Plate XV.), consisting, as the name implies, of cuts winding round the tree trunk to the ground, which tapped a maximum area without actually ringing the tree. Where a tree was substantial enough several such cuts were made, giving rise to the multiple spiral method; and when the distance the latex had to flow was found to be excessive, and it disclosed a tendency to coagulate before reaching the receptacle, cups were placed at more reasonable intervals, and the method called the half-spiral. Several other methods of more or less utility were suggested and tried, such as



the inverted V, thus  &c., but were not found to have any great advantages, and never became popular.

Of these methods, for general purposes, the full herring-bone is the best and most useful, and next to it perhaps the ordinary V. The disadvantages of the V's, however, are in the necessity of fixing the receptacles somehow on the tree, which is apt to injure the bark and render the surface uneven for subsequent tapping, whereas in the herring-bone systems the main vertical channel may be taken to the ground, where the cup may be easily and quickly placed and rest safely. The spiral methods, owing to the amount of walking round necessary, have been found to take somewhat longer to cut or pare, though otherwise satisfactory.

As the processes of tapping evolved from a crude gashing to a delicate shaving of the bark tissues, new and appropriate implements were devised.

To the ordinary pruning knife some sort of a gauge or guide was added to prevent too deep cutting, and it was also found that from the position and angle in which the implement had to be held that something of the nature of a chisel was more expedient and convenient.

A large number of tapping knives have been put on the market. The principal of these are:—The Par  chisel (1); Mackenzie's knife (2); Macadam-Miller knife (3); the Bowman-Nothway set of tapping implements (4); the safety knife (5); Holloway's (6); and Michie-Golledge's knives (7). The numbers correspond with those in Plate .

The style of these may be gathered from the illustrations, and they may be roughly classed as those having adjustable guards or guides, those with immovable guards, and those with no guard at all. Nos. 1, 2, and 3 come under the first category; No. 4 under the second; and Nos. 5, 6, and 7 as having no guard, and therefore requiring somewhat more skill or knack in using. Besides these, that may be called the regular tapping knives, there are others used more or less exclusively for making the first cut into the bark or opening up. For this purpose, either the hooked Holloway knife (Plate XVI.) or the Bowman-Nothway opening knife (Plate XVI.) may be used; if there be any preference, it is, I think, in favour of the former, as more control can be

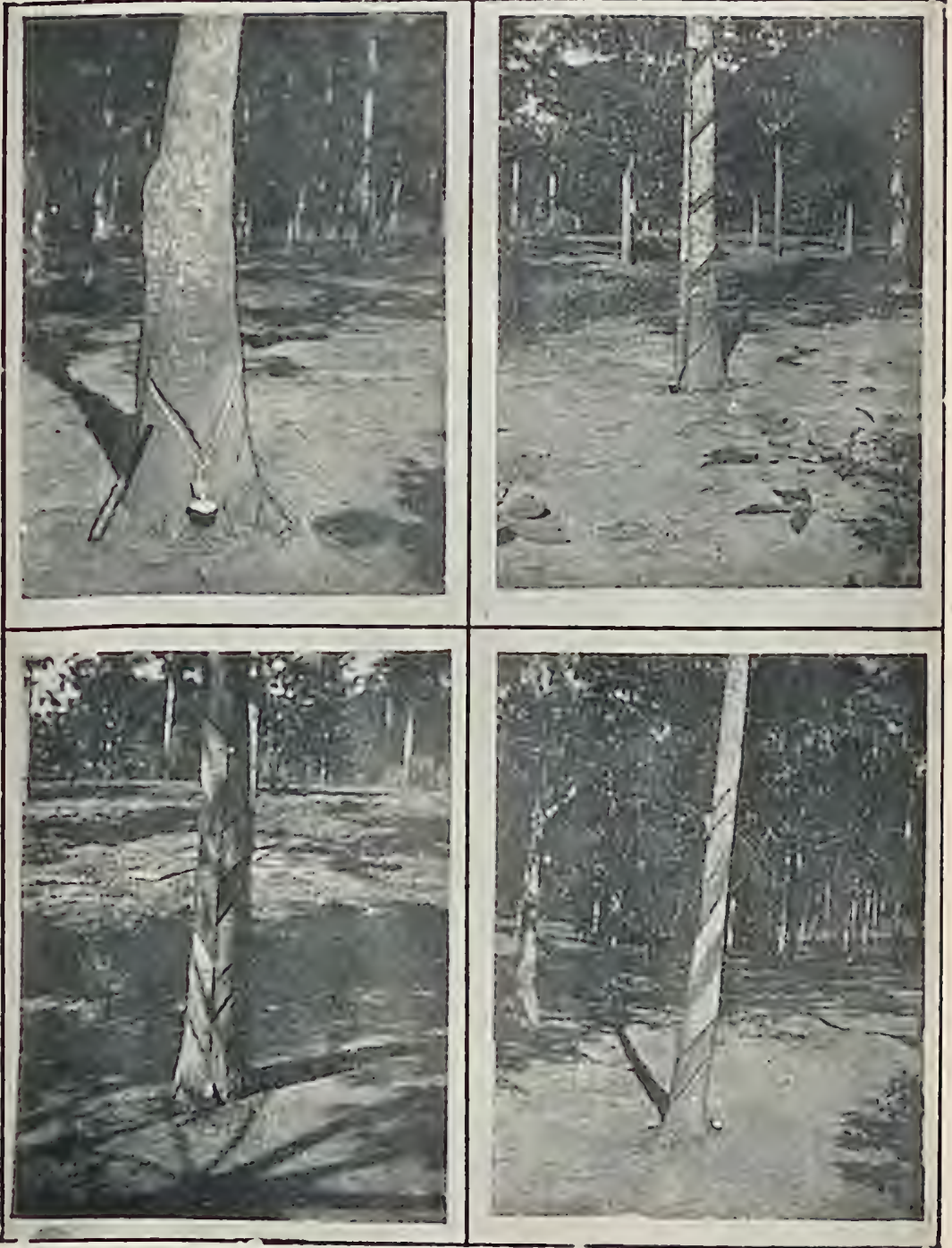

PARA RUBBER TREES TAPPED AT THE KAMERUNGA STATE NURSERY, CAIRNS.

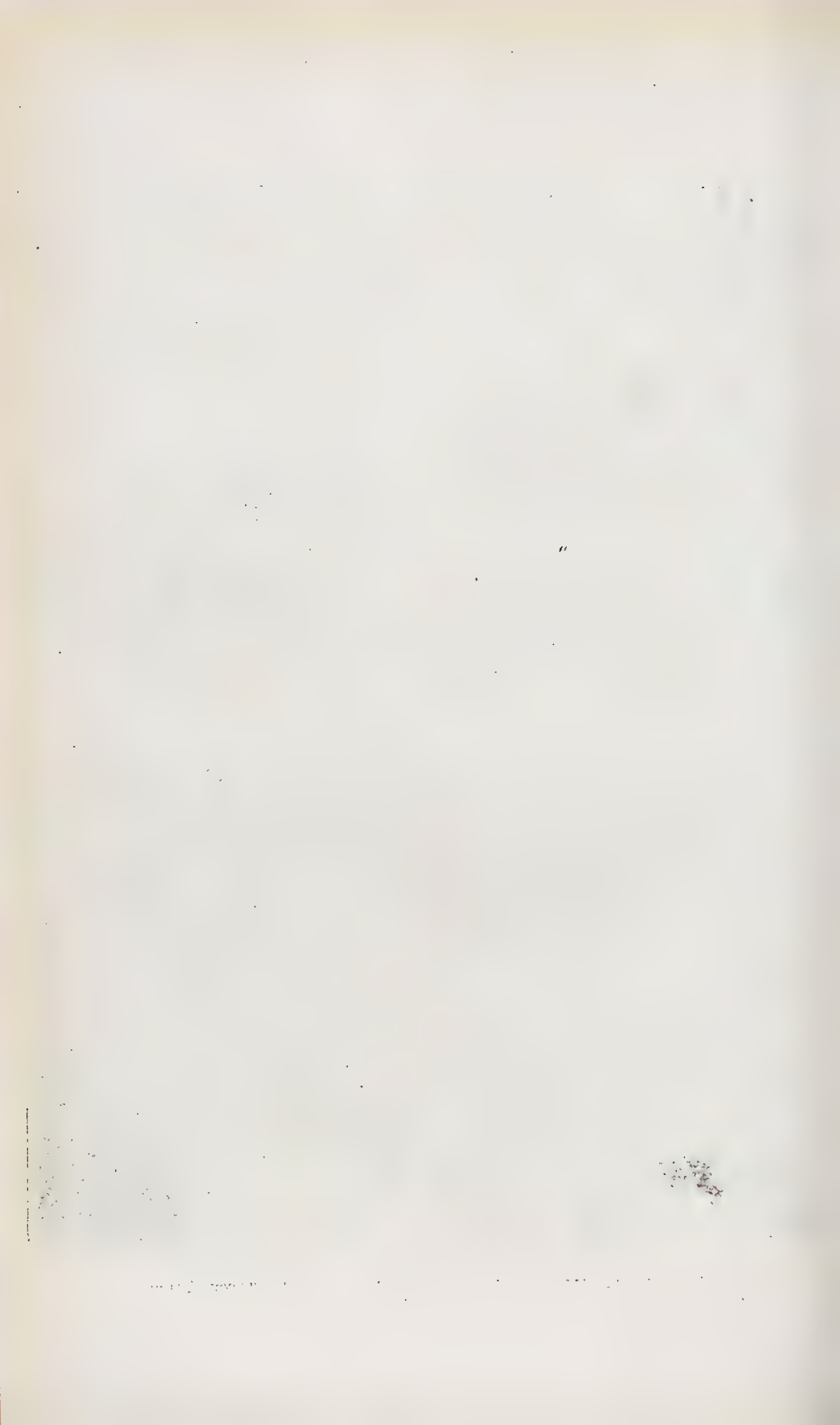
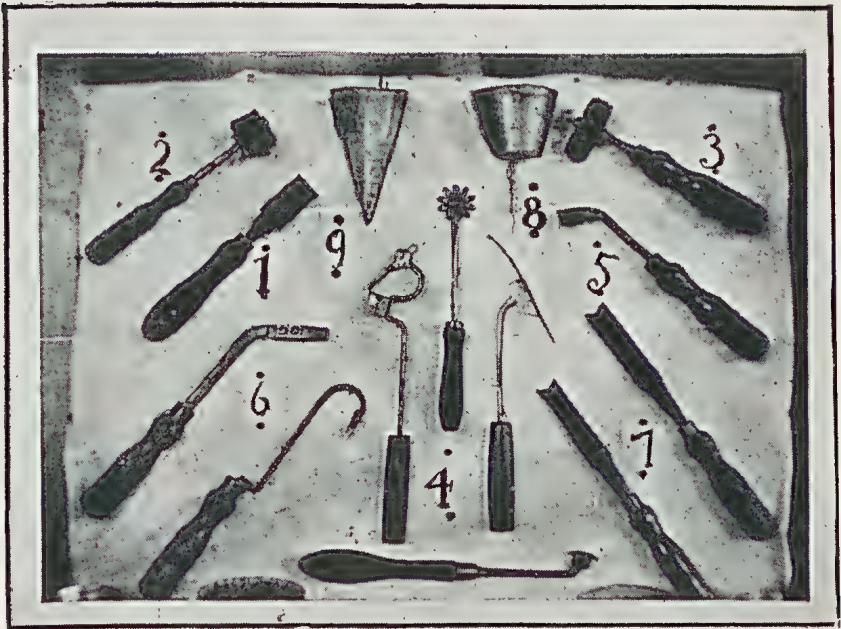

Plate XVI.



RUBBER-TAPPING IMPLEMENTS.



TAPPING PARA RUBBER TREES AT THE KAMERUNGA STATE NURSERY, CAIRNS.

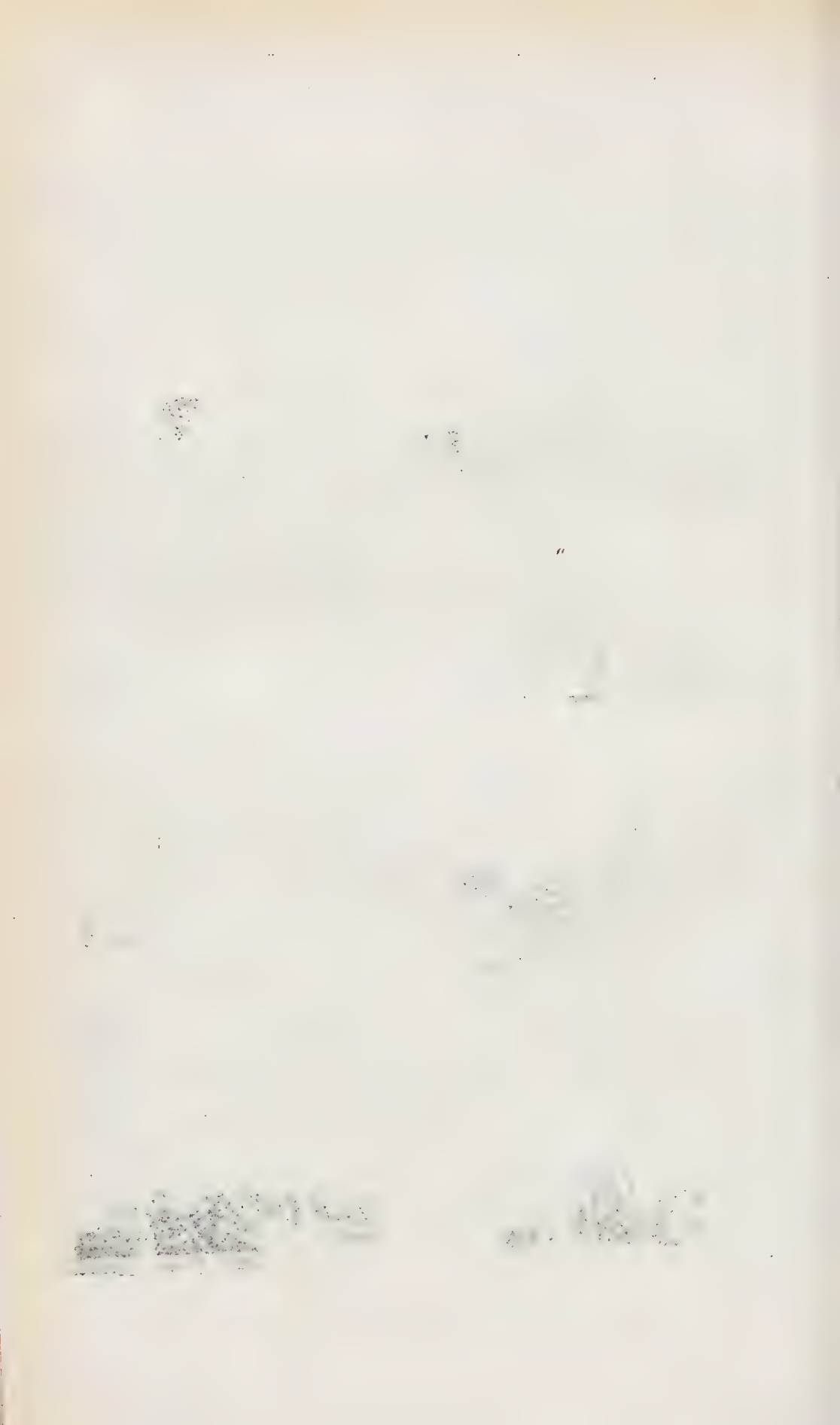

exercised while using it. It might be thought that the knives that had adjustable guards were obviously the best, but it has been found that, while useful at first, the thickness of the bark, not only on different trees but on different parts of the same tree, varies so materially, and so much time was lost in adjusting, that once the knack was obtained no guard at all was necessary, and indeed was almost a hindrance.

Therefore, the simplest knife or chisel has become the most popular, and the last-mentioned, or Michie-Golledge tapping knife, will be found the one most in use and likely to be used.

Having decided upon the method and implement—let us say the full “herring-bone” system and the Michie-Golledge knife or chisel—the first thing for the grower to do is to mark out his trees.

If the modern system of shaving off a thin piece from the lower part of the original cut is to be adopted, which, as explained above, is obviously the best, as giving the maximum returns with a minimum amount of damage to the tree or loss in bark or tapping area, the regularity of the first cutting is of considerable importance.

The first cut made in the tree is the vertical channel, the object of which is to allow the latex to run readily from the ends of the various more or less horizontal cuts to the receptacle. This, therefore, should be plumb, and may be marked off by means of any rough plumb-line. Plate XVII. is an illustration of the method of opening up. The cut may, however, be made from below upward or from the top downward, as may be most convenient. The actual angle at which the side cuts are made does not particularly matter, provided they are steep enough to allow the somewhat thick latex to flow readily.

If too steep or nearly approaching the vertical, but little area comparatively is tapped, as the latex cells run vertically; and if too flat or nearly horizontal, the latex, instead of flowing along the cut and down the channel made for it, is apt to run over the trunk of the tree at any point and be lost, or at least be most difficult to collect, and then only as second-rate or scrap rubber. The length of the branching cuts depends upon the area of tapping surface available, or, in other words, the size of the tree.

On an old and large tree 1 foot in length for such cuts will be found as long as can be conveniently made. On small trees it is a good rule never to include more than half the circumference. Thus, on a tree of, say, five years of age, 6 inches in diameter, the side cuts should be 4 inches to 5 inches in length only, if on both sides of the vertical channel, or twice this if only on one side (half herring-bone). Generally, too, it will be found that, unless the trees are exceptionally even in growth, the cuts nearer the ground will be longer than those higher up the trunk. With large trees it is better to have a number of “herring-bone or “V” systems than to have unwieldy side cuts, and, with the spiral system, to make half or multiple spirals of them.

To ensure these side cuts, which should be alternate rather than opposite, being parallel, a good method is to have a piece of thin tin or zinc cut to the desired shape—viz., a four-sided figure, with the parallel sides at an angle of

about 45 degrees with the top and bottom, thus  This, when one of the

sides is held straight with the vertical cut, can be used as a gauge, and the wings marked off with a piece of chalk or charcoal. Once thus carefully marked off, subsequent cutting will be found easier and more regular tapping area will be conserved, and the cuts, when they ultimately meet, will be found to do so nearly equally and without waste.

The vertical channel, being only a channel to conduct the latex to the receptacle and to prevent it spreading over the tree, need only be a light one, and one-quarter of an inch or so deep will be found enough. This channel is not ordinarily touched or cut again after being once opened unless the growth

of renewed bark renders it necessary, and then it is only lightly reopened to about its original width or depth.

The transverse cuts, on the other hand, to get the maximum flow of latex, must be as deep as possible short of cutting into the cambium. This matter of the depth to which the bark may be cut into with safety is perhaps the most important in the whole process of tapping. The work of ringbarking the trees affords an apposite illustration.

There we wish to kill the trees, and therefore it is essential that all the bark be removed, and even the sapwood cut into, for we know that if not deeply done the bark will grow again, and the tree recover instead of die off. In this case the opposite is desired, for we not only want the trees to live, but the bark to grow again as quickly as possible, that we may tap it again, and so care must be taken that the cambium or delicate viscous cuticle between the actual bark or cortex and the sapwood, from which the cells of the bark are formed, is not cut through and removed. It will require a little practice to avoid doing this, but this is soon attained. When the cambium has been so damaged, the wound is often, indeed generally, covered by bark again ultimately, but close investigation will show that the growth of bark in that case has been over it and from around the wound and not on it, and the result is always a lumpy or uneven surface, making subsequent tapping operations most difficult.

In width both vertical channel and first or opening slanting cuts shou'd be $\frac{3}{8}$ to $\frac{1}{2}$ an inch, which will be found quite sufficient for subsequent working.

The opening up of trees will be found to take a little time, and the number that can be done in a day not great, at any rate, at first; but, for reasons explained above, it is better to do it carefully and well than risk damage to a tree than can never be again undone. Subsequent tapping consists of paring off the least possible thickness of bark sufficient to open up the cells and start the latex flowing again. The bark will be found granular rather than fibrous in texture, so that with a sharp tool the necessary thin shavings may be pared off quickly and neatly with but little practice. In any work sharp tools give better results than blunt, and it would seem scarcely necessary, perhaps, to add that the rubber tapping knife should be kept sharp. In tapping rubber a blunt knife is an expensive form of laziness, and it wastes bark surface by tearing instead of clearly cutting; it renders the scrap difficult to take off, and, owing to extra power required, is far more apt to slip and to make ugly wounds in the cambium, when it does slip, than is a sharp knife.

Immediately a tree is opened or tapped, at the bottom of the vertical channel a small tin spout is fixed. This consists of any small piece of tin, galvanised iron, or zinc, about 2 to $2\frac{1}{2}$ inches long by 1 to $1\frac{1}{2}$ inch wide, slightly bent longitudinally, which is pressed into the bark with, if necessary, a light tap of the handle of the knife, and its object is to conduct the latex from the duct to the cup. These spouts are not affixed daily, but are left in the tree while the tapping operations continue. In Plate XV. these spouts will be noticed just above the collecting cups.

The collecting cups, used for catching the latex as it slowly flows or drips for the spouts, are of various sizes, generally $2\frac{1}{2}$ to 3 inches wide at the top and sometimes sloping or rounded at the bottom, but not to such an extent that they will not readily stand on level surfaces. These are of block tin or enamelled iron, and are seamless—that is, blocked from one piece—so that no corners exist in which latex might coagulate or make the tins be difficult to clean. As a matter of fact, almost any small receptacle could be used, but, as the presence of any dirt, rust, &c., would be detrimental to the colour and quality of the rubber, enamel tins that can be kept quite clean are best. In short, cleanliness is as important in rubber-tapping as in dairying.

Very similar tins are often used attached to the tree at the top end of the vertical channel, from which water is allowed to drip for the purpose of assisting the flow of the latex into the receptacles and preventing coagulation on the tree. These are called "drip-tins," and are usually of two kinds: the

first, a species of zinc funnel with a small brass screw, by means of which the drip can be regulated; and the second, a commoner one, of galvanised blocked tin, shaped like a collecting-cup, but with a small hole in the bottom and near one edge, through which a small piece of loose cotton-wick is inserted.

These drip-tins are affixed by means of tacks or small pegs to the tree and left there, and a given quantity of water, either pure or mixed with formalin, ammonia, or any other chemical that may be required, is put into them at the time of tapping.

The use of drip-tins is deprecated by some planters on a large scale as being too troublesome, unnecessary, or for various other reasons. It has been stated that water coming in contact with the newly cut or opened latex-ducts tends to shrink them and stop the flow. This may be so, though I have not observed it to any appreciable extent. In any case this would only apply to the spiral or similar system of tapping, for drip-tins cannot be conveniently used with other methods, except the "herring-bone," and with this I have found them very successful and satisfactory.

With this latter method the water flows only down the vertical channel, and not over the newly cut surfaces.

Water mixes readily with Pará latex, the ordinary thick and viscous secretion being held apparently in complete solution in water, and becoming a thin milky liquid, which is easily strained and manipulated. When in quantity water retards the coagulation somewhat, but is not in any way detrimental to the rubber, and just exactly the same proportion of coagulated rubber will be ultimately obtained as latex existed in the mixture, however much water may have been added.

The best time of day to tap is early in the morning or late in the afternoon, as the flow of latex has been found to decrease somewhat in the heat of the day, and also has then a tendency to coagulate too rapidly and on the faces of the cuts, which adds to the proportion of scrap rubber, is more difficult to collect as well as less valuable, and hinders the natural flow.

Tapping ordinarily in this country should not be continued after about 10 or 11 a.m. or started again before 5 p.m., but in cloudy weather or in well laid out plantations, where the situation is naturally a protected one and the trees shade each others' stems, the time might be lengthened. It is a good plan to start tapping early with the outside or exposed trees first, continuing till 11 a.m., and then collecting the latex, taking it into the shed and coagulating it at once, subsequently collecting the scrap in the afternoon. "Scrap" is the term given to the latex that has coagulated naturally on the cut surfaces of the tree. Nearly always there is some latex that does not flow off, and which, having hardened on the cut, must be removed before the tapping can be continued. It has to be pulled off by hand, and comes away in strings, which are usually rolled into balls. This should be collected, if possible, the same day the tapping is done, and within twelve hours, as after that it is more difficult to deal with. Scrap is consequently to be avoided as much as possible on account of the extra cost of its collection and its somewhat lesser value, due to the unavoidable presence of small particles of bark, &c.

There is no especially recognised season for tapping, which, under favourable conditions, may be continued all the year round. In very heavy monsoonal weather, however, it becomes difficult, if not impossible, owing to the rain-water running down the tree trunk and either mingling with and washing the latex (and a considerable amount of dirt) over the bark indiscriminately or swamping the collecting tins; also, if a good crop of fertile seed is desired, it has been found inadvisable to continue tapping through the blossoming period. During dry periods of the day in the rainy season tapping can be satisfactorily carried out, and the flow of latex will be found rather more free; but, as it is not so thick as in drier weather, it is an open question whether much more is obtained. In very dry weather the flow, on the other hand, will be found to be materially less, though thicker in consistency.

Tapping should be done regularly and as nearly as possible at similar intervals of time to obtain the best results. The frequency with which any one cut may with safety and advantage be reopened depends upon a curious natural action in the growth of bark or new covering of the severed latex cells, by which an extra supply of latex is supplied to the newly healing parts. This is known as "wound response," and is evidenced by a slight swelling or convex form of the newly growing bark. Wound response does not, however, take place at once, and in newly opened trees is often not evident until after several successive tapplings. Even in trees that have been regularly tapped, very little response is to be seen for the first twelve hours after tapping, but within twenty-four hours it becomes very evident. Every other day, therefore, is the most frequent period at which tapping may be best done.

In opening trees for the first time the amount of latex obtained is often little, and may seem most disappointing, but as the operations continue the flow will be found for the above reason to materially increase. Sometimes but little wound response is noticeable for the first week or more, and the operator is inclined to cut away more bark or to cut deeper; this inclination must be combated, however, and patience exercised, for nothing is to be gained by the removal of more bark, and the wound response is not in the least hastened thereby.

When this swelling to almost bursting point of the "latex cells, which is watched for and welcomed by the grower, takes place, it can be understood that but the thinnest of shavings or parings is necessary to open the cells and obtain a steady flow of the valuable "milk."

After tapping, the flow of latex seldom continues for more than about two hours, and often ceases within a few minutes; then the contents of the cups are collected and taken to the store or house for subsequent treatment.

The amount of bark removed in a season or a year varies very much with the nature of the tree. If the transverse cuts are apart, and alternate as suggested, and the tapping is carefully done, the lower cut will not be reached for a twelve month or so with regular cutting three times a week (every other day). Renewed bark should not be tapped for eighteen months or so, and, if possible, left for two years. The growth can be tested from time to time by the point of a penknife.

Plate XV. shows the renewed bark of the previous season's work just above the present cuts. While one-half or side of the tree is renewing its bark, the other side may be tapped. How long this may be continued has not yet been determined, as no trees of any great age that have been submitted to regular tapping exist; but, so far as can be seen, with due care, there is no need for a tree to suffer in its vitality from the tapping operation, and every reason to show that it will not only continue to produce, but to bear more and more as it increases in growth, for a very long time—a lifetime, at least.

Subsequent tapping operations on renewed bark are similar to those described, except that the markings are generally clear enough to enable the operator to dispense with the marking out and measuring necessary in opening up for the first time.

The next article will deal with the treatment of the latex on being brought in from the field.

POLING OF FOURCROYA SUCKERS.

The Fourcroya plant in our illustration was brought to this office last week as a curiosity. But the poling of young suckers is a common occurrence when they are attached to the mother plant which has poled. This shows that care should be exercised, when taking up suckers for immediate planting, not to take them from a poling plant. In any case it is better to place all suckers in a nursery for a year, during which time they will attain the proper size for planting out, and any which come from the source mentioned will in that time have developed the short, slim pole here shown.

Plate XVIII.



POLING OF FOURCROYA SUCKERS.

Chemistry.

PLANTS POISONOUS TO STOCK.

By J. C. BRÜNNICH, F.I.C., Chemist to the Department of Agriculture and Stock.

THE WALLFLOWER POISON-BUSH.

In our State, where stock-raising and dairying are our most important industries, a knowledge of all plants which may have deleterious properties when used as fodder is an absolute necessity. Unfortunately, very little thorough scientific work has been done in this respect, and many fodder plants which are classed as good fodders by some are reputed to be poisonous to stock by others. An exhaustive investigation with regard to the composition of the very large number of plants which are reputed to be poisonous should form an important part of the duties of the Department of Agriculture and Stock, and would necessitate the combined efforts of the botanist, chemist, and veterinary surgeon.

The chemical work involved in these researches is generally a very laborious one, frequently giving, even after months of patient work, only negative results, and only occasionally the investigator is fortunate enough to isolate the chemical compounds which are the cause of the poisonous effects. In many cases the poison is of such volatile nature or so easily decomposed that it disappears on drying, and the plant, when reaching the laboratory, has lost all its poisonous properties; in a good many instances the plants contain the poison only at a certain stage of their growth; in other cases, again, the compound in a plant may in itself be harmless, but, on being consumed by the animal as fodder, a decomposition takes place during digestion which produces poisonous compounds. As an instance of the latter classes must be mentioned the ill-effects of sorghum and all allied fodder plants, the poisonous properties of which were for a long time shrouded in mystery, and were subject to many speculations and theories, until Messrs. Dunstan and Henry conclusively proved the presence of a glucoside in the young plants which, on decomposition, yields hydrocyanic or prussic acid.

One of our most notorious poisonous plants in the northern parts of our State, which is also found pretty well over the whole of Northern Australia, is a shrub belonging to the order Leguminosæ, the WALLFLOWER POISON-BUSH. This plant is described in "Plants reputed Poisonous and Injurious to Stock," by F. M. Bailey, F.L.S., Colonial Botanist, and P. R. Gordon, Chief Inspector of Stock, as follows:—

Gastrolobium grandiflorum, the Wallflower Poison-bush. This is also known as Australian Poison-bush and the Desert Poison-bush.

It is a dwarf or at times tall shrub, of a somewhat light-grey colour, being more or less clothed with short soft hairs. Leaves usually opposite, of a harsh dry nature, oblong, and always more or less notched at the top, 1 to 3 inches long. Flowers in the axils of the leaves near the end of the branchlets, in short often dense panicles, chocolate-coloured, or resembling the flowers of the garden wallflower; flower nearly 1 inch in diameter. Pods softly hairy, about 1 inch long. This dangerous shrub is met with in North Queensland (inland) and North Australia. Others of the genus constitute the most dangerous poison-bushes of Western Australia.

There is no doubt as to the poisonous nature of this bush. So virulent is its poison at certain stages of its growth that working horses and teams of bullocks have to be yarded at night when passing through belts of the plant. Very heavy losses have occurred from it on the road from Cleveland Bay to Hughenden. Drivers and teamsters state that it ceases to be poisonous after the flower appears. On analysis, Mr. Staiger failed to discover any active

poison, but the analysis was made from dried specimens, and he is of opinion that if freshly-cut specimens were analysed an active poison might be discovered.

Species of the following allied genera:—*Isotropis*, *Gompholobium*, and *Oxolobium*—in other parts of Australia, are considered as more or less dangerous poison plant.

Samples of plants of these genera have been examined repeatedly by a great number of scientists, without getting positive proofs of the presence of poison compounds, and only after a very long investigation, carried out at the Government Laboratory of Western Australia, poisonous alkaloids were isolated from the York Road Poison Plant (*Gastrolobium calycinum*) and Box Poison Plant (*Orylobium parviflorum*), as published in "Examination of the Western Australian Poison Plants," by E. A. Mann, Government Analyst and Chemist to the Department of Agriculture of Western Australia.

The methods employed by Mann and Dr. Ince were used at our laboratory for the extraction of a large quantity of *Gastrolobium grandiflorum*, which was collected at Torrens Creek by Stock Inspector Collins, of Hughenden. Two large bags of the plants were received, but every one of the branches had fully developed seed pods, with only a few flowers here and there; and this fact must account for the failure to isolate the poisonous alkaloid. Three different lots, of about 3 lb. each, of the powdered plant were extracted with acidulated water (containing 1 per cent. of H_2SO_4), the extract cleared with lead acetate, the filtrate treated with H_2S to remove excess of lead, H_2S driven off by a current of air, and the alkaloid precipitated with tannic acid. In the precipitate the alkaloid was set free by treating with freshly-prepared lead hydroxide, the alkaloid dissolved out with alcohol, and, after evaporation at ordinary temperature, allowed to crystallise as hydrochloride. Only in one of the extracts a very slight amount of crystallised residue was obtained, which gave alkaloidal reactions, and evidently the plants were too old; and the opinion expressed by stock-owners, that the shrub is not dangerous after flowering, appears, therefore, to be quite correct.

A further supply of the plant was obtained by favour of Dr. Thos. L. Bancroft, who for years has made a special study of the pharmacology of our native flora. These plants, collected at Stannary Hills, North Queensland, were considerably younger, showed no seed pods, but were well in flower. On extraction of the plants a few grains of a residue were obtained, which gave distinct alkaloidal reactions and crystallised in needles similarly to those described by Mann for Cygnine hydrochloride. This residue had a peculiar odour, resembling nicotine. The quantity of the alkaloidal residue was too small to be purified by recrystallisation, and the crude alkaloid itself was handed to the Principal Veterinary Surgeon and Bacteriologist of our Department, Mr. Sydney Dodd, F.R.C.V.S., for physiological experiments on guinea-pigs; and I herewith give his report in full:—

EXPERIMENTS WITH ALKALOIDAL EXTRACT OF "GASTROLOBIUM" ON GUINEA PIGS.

First Experiment.

| | | |
|----------------------------------|----------------|---|
| 15th June, 1908. | | Guinea pig No. 1. Boar. Live weight, 1 lb. 14 oz. 8½ drams. |
| Injected 9 a.m., subcutaneously, | | with one-tenth grain gastrolobium residue in 1 c.c. of water. |
| 3 | minutes later— | Breathing slightly hurried. |
| 4 | " " | Breathing rapid, slight salivation, slight spasms like strychnine poisoning. |
| 5 | " " | Marked spasms of body, legs apparently unaffected. Spasms succeed each other very rapidly. Head is stretched out. |
| 6 | " " | Animal tries to move, appears to retain use of limbs, spasms continue. |
| 7-8 | " " | Same. Still able to walk a little, retains sight. |
| 9 | " " | Spasms not so marked. |
| 10 | " " | Animal appears exhausted. |
| 12 | " " | Quieter, very few spasms. When animal attempts to move spasms recur very markedly. |
| 16 | " " | Animal able to walk about, but easily becomes exhausted. |
| 18 | " " | Very quiet, no spasms, breathing shallow. |
| 20 | " " | One or two convulsions, then lies stretched out full length, but afterwards reassumes natural posture. |

34 minutes later—An occasional spasm.
 42 " " On being moved slight spasms appear, then lies very still.
 55 " " Improving, breathing better, no spasms.
 82 " " Much brighter.
 3½ hours later—Quite recovered, but weak.
 Animal showed no ill effects next day.

Second Experiment.

Guinea pig No. 2. Sow, pregnant. Live weight, 2 lb. 1 oz. ½-dram. Administered per os one-fifth grain in 2 c.c. s. water, by means of a pipette.
 Animal vomited slightly during administration, but only a few drops of the liquid were spilled.

3 minutes later—Breathing deep, and rather hurried.
 5 " " Very slight spasms.
 30 " " Animal appears quite well, only thing noticeable is profuse and frequent urination.
 No subsequent ill effects of any kind were observed.

Third Experiment

Guinea pig No. 3. Sow, pregnant. Live weight, 1 lb. 15 oz. Injected subcutaneously with one-fifth grain of gastrolobium residuo in 2 c.c. s. water.

3 minutes later—Breathing rapid and shallow, spasms commencing, chiefly in fore part of trunk.
 7 " " Very slight spasms.
 9 " " Spasms increasing in severity and rapidity
 10 " " Spasms very violent, affects whole of body.
 12 " " Spasms very violent and continuous, affects whole of body; animal lies stretched out full length.
 13 " " Spasms intermittent, but on animal being moved they become more violent and continuous.
 16 " " Animal exhausted, spasms slighter.
 18 " " Animal moving about a little, but movement causes recurrence of spasms, pupils very dilated.
 21 " " Animal still moving about, spasms slight, but easily gets exhausted.
 30 " " Animal very quiet, spasms slight, and not so frequent.
 40 " " Ditto ditto.
 60 " " Slight spasms, eyes seem very sensitive to light, keeps them almost closed.
 2½ hours later—Animal sits with its head in a corner, refuses to move. If moved forcibly, violent spasms set in.
 3 to 7 " " Spasms still continue intermittently. Animal quite prostrate; appears on point of death. Breathing hardly discerned.
 Next day animal apparently quite recovered. No symptoms of any kind.

Fourth Experiment.

30th June, 1908. Guinea pig No. 4. Sow. Live weight, 1 lb. 13½ oz. Injected subcutaneously with ½-grain gastrolobium residuo in 1 c.c. of water.

½-minute later—Breathing becoming rapid.
 1 " " Breathing very rapid, chest heaving, animal uneasy.
 2 " " Violent convulsions setting in very suddenly.
 2½ " " Animal bounding into the air, then rolling over and over. Marked opisthotonos; body bent back like a bow.
 3 " " Still violent convulsions, animal not still from the commencement of the seizure.
 3½ " " Animal almost comatose, only one or two spasms.
 4 " " Animal just breathing.
 4½ " " Animal dead after giving a few short gasps for breath.

Post-mortem examination held immediately.

No reaction at seat of injection.
 Mesenteric vessels injected.
 Lungs markedly congested.
 Liver slightly congested.
 Heart greatly distended; responds readily to stimuli; auricles still contract half an hour after death.

It is particularly interesting to note that the results of these experiments agree very closely with the experiments made by Dr. Blackburne, in Western Australia, with the pure alkaloid extracted from *Gastrolobium calycinum*.

A characteristic of this alkaloid is the ease with which it is decomposed, and for this reason Mr. Mann advocates as an antidote the use of a solution of potassium permanganate (Condy's fluid), which has been used with great success in America for the treatment of stock poisoned by eating certain indigenous plants. A few practical experiments, which already have been carried out in Western Australia by stock-owners, seem to indicate a like success of the use of permanganate as an antidote against gastrolobium poisoning, and a great number of valuable stud sheep have been saved by its use.

ANALYSES OF FERTILISERS (SUPPLEMENTARY LIST).
TAKEN AND ANALYSED UNDER "THE FERTILISERS ACT OF 1905."

| Fertiliser. | Where Obtained. | Moisture. | PHOSPHORIC ACID P ₂ O ₅ . | | | Potash, K ₂ O. | Nitrogen, N. | MECHANICAL CONDITION. | | | Remarks. |
|----------------------------|----------------------------------|-----------|---|------------------|--------|---------------------------|--------------|-----------------------|---------|-------|----------------------|
| | | | Water Soluble. | Citrate Soluble. | Total. | | | Coarse. | Medium. | Fine. | |
| Fertiliser | Birt and Co., Murarrie | 7.34 | ... | ... | 21.08 | ... | 3.20 | ... | ... | ... | |
| Dried blood | ditto | 10.98 | ... | ... | ... | ... | 13.14 | ... | ... | ... | |
| Ammonium sulphate (B.S.A.) | Brisbane Gas Company | .20 | ... | ... | ... | ... | 20.50 | ... | ... | ... | |
| Dried blood | Bergl Australia, Bowen | 10.03 | ... | ... | 1.80 | ... | 14.00 | ... | ... | ... | |
| Pineapple Manure | Webster and Co., Brisbane | 7.26 | 11.60 | ... | 12.62 | 8.24 | 3.00 | ... | ... | ... | N as NH ₃ |

J. C. BRÜNNICH,

Chemist to the Department of Agriculture and Stock.

Animal Pathology.

STOMACH OR WIRE WORMS IN SHEEP.

By SYDNEY DODD, F.R.C.V.S.,
Principal Veterinary Surgeon and Bacteriologist.

Stomach worms in sheep and calves are known to exist pretty generally throughout the world, and are often a source of great loss to stock-raisers. In some parts of Queensland this condition is one of the most serious drawbacks to sheep-raising, the mortality amongst lambs being very high. In calves, also in some districts, parasitic gastritis or stomach worm is very prevalent, more especially on the coastal districts or where the climate is moist. In the latter animal it gives rise to a condition known amongst stock-owners as "bottle."

Stomach worms are to be found in ruminating animals of all ages, but in adult sheep and cattle their presence, unless in very large numbers, does not usually give rise to any outward symptoms, although they are a source of infection to young stock. It is in lambs and young calves that their effects are most serious.

Symptoms.

The most constant symptom is scouring, and this is seldom or never absent. Accompanying the diarrhoea is rapid loss of flesh and loss of appetite. An unusual thirst is often seen, and lambs at times show a tendency to lick sand or earth; but the evidence of this latter is often only seen when the fourth stomach is opened after death. The temperature may be above normal. There is no cough as a rule.

In the more chronic cases, the disease is accompanied by dropsical swellings of the dependent parts, chiefly seen under the lower jaw. The swelling in the latter place in calves is said by stock-owners to have some resemblance to a bottle, hence its popular name in Queensland—"bottle." There is also great anæmia, seen in the marked paleness of the visible mucous membranes, such as of the eye and mouth.

In some cases the course of illness is very acute in very young animals—these sometimes dying in a very few days, but, as a rule, the course is a chronic one, the animals being more or less ill with the above symptoms.

A positive diagnosis of this disease may be made by killing one of the badly affected animals and opening the fourth stomach, then emptying its contents into a shallow glass dish or basin. If the worms are present in great numbers, as they usually are, by carefully searching the liquid one can see them wriggling about very vigorously, like eels. They are from $\frac{1}{2}$ to $1\frac{1}{2}$ inch long, and about as thick as a pin. Or, in order to observe them better, one should empty out the stomach contents and scrape the lining of the stomach with a knife, then mixing the scraping with a little clean water in a small flat-bottomed glass dish.

The worm which is most prevalent in these conditions is known as *Strongylus contortus* (or *Hæmonchus contortus*), receiving its name "contortus" owing to its having a red-and-white twisted appearance like a barber's pole, due to the arrangement of the ovarian tubes around the intestines. The body of the worm is usually brown or reddish.



Strongylus contortus
(Stomach Worm,
natural size).

LIFE HISTORY OF THE TWISTED STOMACH WORM.

The *Strongylus contortus* is ovo-viviparous—that is, the eggs contain living embryos before the former are discharged from the adult worm.

The life history of this worm has recently been worked out by Mr. Ransom, Zoologist to the United States Department of Agriculture, and is as follows:—

In the stomach of affected animals, the worms, after being fertilised by the male, produce large numbers of eggs, which are very minute. These are passed out with the droppings, and are scattered widely over the paddocks.

If the temperature is above 40 degrees to 50 degrees Fahr., the eggs hatch out in from two hours to a few weeks, depending upon whether the temperature is high or low. If the temperature is below 40 degrees Fahr., the eggs remain dormant, and can remain in this condition for two or three months, and afterwards hatch out if the weather becomes warmer. Freezing or drying soon kills unhatched eggs. The minute worm which hatches from the eggs feeds upon the organic material in the manure, and grows until it is nearly one-thirtieth of an inch in length. Further development then ceases until it is swallowed by a sheep or other ruminant, after which it again begins to grow, and reaches maturity in the fourth stomach of its host in two or three weeks. The chances of the worms being swallowed are greatly increased by the fact that they crawl up blades of grass whenever sufficient moisture, such as a rain, fog, or dew, is present.



Embryo of *Strongylus contortus* coiled on the tip of a blade of grass.—After Ransom. Enlarged 100 times.

The young worms which have reached the stage when they are ready to be taken into the body of the host are greatly resistant to cold and dryness. They will survive repeated freezing, and have been kept in a dried condition for thirty-five days, afterwards reviving when moisture was added. At a temperature of about 70 degrees Fahr. young worms have been kept alive for six months, but experiments have shown that land over which no cattle, sheep, or goats have been allowed to graze for a year will be free from infection at the end of that period.

The time required for a clean pasture to become infectious after sheep, cattle, or goats are placed upon it depends upon the temperature—that is, the eggs of the worms contained in the droppings must hatch out, and the young worms develop into their final larval stage, at which stage they are able to continue their development in the body of their host, and the rapidity of this depends upon the temperature. The final larval stage is reached in three or four days to three to four weeks after the eggs have been dropped from their host, according to the temperature conditions. It has been proved that eggs or newly-hatched larvæ are unable to develop if swallowed by an animal—a certain degree of development must first take place outside the body of its host—and although a certain amount of infection may take place through drinking from pools soiled by droppings, yet the most frequent source is the pasture; and it explains why this disease is much more prevalent on the coastal district or where the rainfall is heavy, thus keeping the grass continually moist.

TREATMENT.

In America very elaborate methods have been devised for freeing the pastures from infection, but generally speaking the conditions obtaining in this country do not admit of their practical application here.

Various remedies have been used for destroying stomach worms. The one used most commonly in South Africa is a solution of bluestone (sulphate of copper), and I have frequently used it with satisfactory results. The bluestone should be in clear blue crystals, with no white patches or crusts. It should not be dissolved in an iron or galvanised vessel—an enamelled bucket answers very well. Rain water is best for making the solution.

The doses recommended are as follow:—

For Lambs: Take 1 lb. (Avoirdupois) of pure bluestone and 1 lb. of Colman's mustard (fresh). Mix well with 12 gallons of rain water.

Dose for Lambs: 3 to 6 months old, give 2 oz.; 6 to 9 months old, 3 oz.; 9 to 12 months old, 3½ to 4 oz.

For Sheep: Take 1 lb. (Avoirdupois) pure bluestone, 1 lb. Colman's mustard (fresh). Mix with 10 gallons of rain water.

Dose for sheep over 12 months old, give 4 oz.

Dose for calves, 15 to 30 grs. of bluestone dissolved in 1 quart of rain water.

The animals should be fasted from twenty to twenty-four hours before dosing, and they should be kept away from water on the day they are dosed. It is important that the bluestone and water be accurately weighed and measured, and a graduated medicine glass should be used to measure out the various doses individually. In dosing sheep it is better to leave them standing on all four legs, as it has been found by experience that if the dose is taken quietly when the animal is in the standing position most of the liquid will pass directly into the fourth stomach, while if the animal is placed on its haunches, only part of the liquid goes immediately into the stomach where it is needed. An assistant places the sheep between his legs, and raises its nose up to a level with its forehead. The person giving the dose then places his hand lightly over the animal's nose and inserts one or two fingers into the left side of the animal's mouth in order to open it. At the same time he inserts the neck of the bottle containing the measured dose, and pours gently as fast as the animal will drink. No attempt should be made to force the animal's mouth wide open or to hold the nose high in the air.

Many sheep are killed by careless or hurried dosing. Great care should be exercised in order to prevent the liquid going down "the wrong way"—that is, into the lungs. Therefore, if an animal coughs or bleats, stop pouring and lower the head at once. Do not be in a hurry to get the job finished or try to break records. If a very large number of animals are to be drenched, it is better to drench a certain proportion daily, and turn those dosed into a separate paddock until the whole are finished.

It is also advisable before dosing the whole of the flock to test the drench by dosing a few of the animals first, and then waiting a day or so to see whether any bad result follows.

In America good results have been obtained from a single dose of a 1 per cent. solution of coal tar creosote. The solution is made by shaking together 1 oz. of coal tar creosote and 99 oz. of water (making 5 pints altogether). The dose of this mixture is as follows:—

Lambs, 4 to 12 months old, 2 to 4 oz.

Sheep, 12 months and over, 3 to 5 oz.

Calves, 3 to 8 months old, 5 to 10 oz.

Yearlings, 1 pint.

Coal tar creosote has been found to vary greatly in composition, and in the United States complaints have been made that the drug dispensed by some chemists as coal tar creosote has failed to give satisfactory results.

Gasoline is one of the popular remedies in America for stomach worms. If gasoline treatment be adopted, it is important to repeat the dose, and it is usual to give it on three successive days. The evening before the first dose is to be given the animals are shut up without feed or water, and are dosed at 10 o'clock the next morning. Three hours later they are fed and watered. At night they are again shut up without feed or water. The next morning the second dose is given, and the third morning the third dose, the treatment before and after dosing being the same in each case.

The doses are :—

Lambs, $\frac{1}{4}$ -oz.

Sheep, $\frac{1}{2}$ -oz.

Calves, $\frac{1}{2}$ -oz.

Yearlings, 1 oz.

The dose for each animal is mixed and given separately in linseed oil or milk. Gasoline should not be given in water.

In addition to whatever treatment is adopted, it is very necessary that the strength of the animals should be maintained by generous feeding.

PREVENTION.

From what has been said in the preceding pages, it will be seen that worms have no power of reproduction outside the body of their host, and therefore the chances of worms infecting an animal are in direct relation to the number of sheep and cattle grazing over the pasture, and also the size of the latter. It will be easily understood that if the area of the grazing land is large and the relative number of sheep and cattle on it small, there is less probability of an animal eating grass that is contaminated with worm embryos than there would be if the conditions were reversed—that is, a small grazing area and a large number of animals on it. In other words, overstocking of land plays a great part in the cause of this disease. Paddocks on which a large number of lambs are grazed are certain to be greatly contaminated, and lambs put to graze on this the following season run great risk of infection. A few worms may probably be found in most sheep, but their eggs cannot develop into mature worms inside the body. They must be passed out with the excrement, and after a certain stage of development find their way into the body of another lamb or calf. From this it is evident that worms may be present for years without any serious loss. It is only when the number of worms swallowed by an animal becomes excessive that the train of symptoms and results ensue.

Therefore, in order to reduce the prospects of infection to a minimum, lambs or calves should not be grazed over ground that has become grossly infested with worms. The larger run they have the better. Also, it should be remembered that moist spots are very favourable places for harbouring the immature worms. If a paddock has become heavily infested, the better way would be to remove sheep and cattle from it for a year, and only use it for grazing horses; or, in some districts that are more closely settled, the land could be cultivated for a year.

Stomach worms are not so prevalent on those runs where the grass has been frequently burned off. This is what one would naturally expect, knowing the life history of the worm; but, unfortunately, this means of keeping down worms is not practicable in many instances, because it is the small selector who often suffers the most heavily, and he cannot, as a rule, afford to burn off his grass; and also worms are most prevalent in moist places, and here the grass is usually too green to burn.

General Notes.

GROWING PUMPKINS IN DRY WEATHER.

We are in receipt of a letter from a correspondent who advises those who fail to grow pumpkins in a very dry time to sow the seed on a heap of rotten straw. His children planted a seed in such a situation. All through the hot, dry weather it grew and flourished, the straw keeping up a supply of moisture. Lately, the crop was gathered, and resulted in a yield of 125 good ripe pumpkins, weighing 1,221 lb., and 30 or 40 green ones, the whole produced on one single vine. Our correspondent, after this experience, intends, in future, to leave a vacant strip of land at intervals in his wheat field, rake the straw into it, and plant pumpkins, as he is convinced that in the driest season good crops of pumpkins may be got by this method.

THE BANANA APPLE.

A new variety of apple, called the "Banana Apple," is spoken very highly of in America, and is said to have realised very high prices. It is claimed to be one of the best of all apples in quality. It is also a beautiful apple, looking like lumps of gold tinged with red on one side. The fruit is large and uniformly fair and free from worm. The tree is a good bearer and fast grower. It is a long-keeping winter apple. Last fall the banana apple fruited in the Hood River, Oregon district, and sold there at 12 dollars per box, which is the highest price ever known for apples in America.

A SWEET-SCENTED DAHLIA.

A sweet-scented dahlia has been introduced by Herr T. C. Schmidt, of Erfurt. The plant originated from Mexico, is of good habit, and the flowers are honey-scented. The blooms are of a shade of orange-scarlet, and borne on long stems, thus rendering them very suitable for use as cut flowers. The plant attains a height of 4 or 5 feet.

MEBOS: A NEW TABLE DELICACY.

Some time ago, Sir Harry Rawson, Governor of New South Wales, called the attention of the Department of Agriculture to a table delicacy made in Cape Colony, called "Mebos," which he thought worth while experimenting with in Australia, and we learn from the "Indian Trade Journal" that Miss Rawson obtained from the Cape a recipe for the process. It is a very simple one:—

Take soft ripe apricots, lay them in salt water (about 2 oz. of salt to a quart bottle) for a few hours. Then lay them on a mat to dry in the sun; the next day press them between the hands to flatten and to let the stone come out. The next day repeat the process. At the Cape it generally dries and becomes "Mebos" in three or four days in the sun, but, if the weather should be damp, they might be dried in heated rooms or a cool oven. To crystallise the "Mebos," lay them in limewater for five minutes till they feel nice and tender; take out, wipe dry on a soft cloth, and rub coarse crystallised white sugar well into each; take 1½ lb. of sugar to 1 lb. of "Mebos." Pack closely, with lots of sugar in between, in jars that will cork well. This is said to make a very nice sweetmeat, and is reported to be a remedy for sea-sickness. The limewater is made by adding two tablespoonfuls of fine lime to a quart of boiling water. This should be mixed well, and, when the lime has drained to the bottom, the clear water may be poured into a bottle, corked, and kept for use.

SEEDLESS TOMATO.

One of the agents of the American Department of Agriculture, working on his New Jersey farm, is said to have produced a new vegetable novelty, in the shape of a seedless tomato. The variety has been called the "Giant," because of the large size that the plant attains. Six years of experimentation was necessary to produce the seedless tomato. Each ordinary tomato contains hundreds of seeds, while the form now developed seldom contains more than 50 seeds, and often none. Before attaining success in his experiments, the Government scientist produced large crops of freak tomatoes. Some plants included clusters no larger than peas. In one instance the fruit had the flavour of a strawberry.

RED PICKLED CABBAGE.

Cut the cabbage into slices on a chopping board. Set it upon a dish in layers, with a sprinkling of salt over each layer. Let it stand for one night, then put it into a stone jar. To every 4 quarts of vinegar add 1 oz. of sugar and 2 oz. of mixed spice; heat this mixture almost to boiling point, and when cold pour over the cabbage, which must be well covered by the liquor.

It is fit to be eaten in seven days, although it improves with keeping, and should be of a lovely colour.

MONEY IN WASTE PRODUCTS.

Many thousands of pounds have been lost annually owing to ignorance of the value of residual waste from the products of the soil, both mineral and vegetable, especially the latter. Old colonists will remember that when cotton was largely grown in East and West Moreton thousands of tons of cotton seed were left to rot in heaps near the gin houses or, in rare cases, used as manure. Vast quantities of molasses were run into the rivers as valueless. Sugar-cane bagasse was left to rot or burnt in heaps on the field. When maize was shelled, the cobs were burnt off. And many other so-called waste substances were destroyed, which to-day are worth as much as if not more than the primary product. Amongst this wasted matter may be enumerated orange and lemon skins. Who in Queensland ever thinks of saving the skins of these fruits? In Spain they are dried and sold for shipment to the Baltic. The skins are quite dry and hard when packed, and the lemon skins sell for from 7 to 11 reals (1s. 4d. to 2s. 1½d. about) per arroba (12½ lb.), the Seville skins bringing 10 to 14 reals (1s. 1½d. to 2s. 9½d. about) per arroba.

A NEW MARIGOLD.

A newly-introduced plant named *Caltha polysepala*, and now selling in England at one guinea per plant, has a curious history attached to it, which (says Mr. J. R. Jackson, in the "Garden") may or may not be legendary. Report says that an Italian peasant found this plant in some unknown corner of the country, and, in consideration of its marvellous size and great beauty, brought it to Rome and laid it at the feet of Pope Leo. The old Pope benignly accepted the offer, and *C. polysepala* established itself in one of the fountains in the Vatican garden. But the Pope would never let anyone possess bud, or seed, or baby of it, and there, year after year, it wasted its sweetness on the desert air, being seen by nobody, except an aged gentleman, who, presumably, had other things to think about. This policy survived Pope Leo, and continued until the English gardener (he is a male Antigone, daring a formal sin to secure the higher holiness) resolved that such a scandal should no longer endure. So he took with him into the Vatican garden's a covey of his sisters, and his cousins, and his aunts, and, while they engaged the custodian in a conversation on Renaissance art, our hero hooked out a root or two with his umbrella. And now Pope Pius is none the poorer, and the whole world is the richer. This plant is described as the ordinary marsh marigold, multiplied by three—in all its parts, leaf, flower, and stem—a tropical-looking aquatic of unequalled glory.

Plate XIX.



POULTRY FOR EXPORT DRESSED IN THE DEVONSHIRE FASHION.

POULTRY FOR EXPORT.

The Department of Agriculture and Stock has received a letter from Messrs. Chas. E. Brooke and Sons, poultry, game, and meat factors, of Leadenhall Market, London, inquiring whether they can obtain poultry in Queensland. The firm state that they have a very large demand, and can purchase an unlimited quantity of chickens, ducks, and turkeys. The accompanying illustration forwarded by Messrs. Brooke and Sons shows two fowls dressed in the Devonshire fashion, which were awarded a first prize and a cup.

Last June, we are informed, turkey hens were sold at 7s. 6d. per pair in the Brisbane markets, and gobblers at from 10s. to 12s. 6d. per pair. The price of hen turkeys in the Smithfield Market, London, on 2nd December last, was 5s. each and gobblers 8½d. per lb., or about 12s. for a good six or eight months' old bird. Turkeys thrive so well in Queensland that it should not be difficult to establish a regular export trade with this class of fowl.

TOBACCO GROWN IN SAND.

Mr. M. J. Frayne recently showed to the Department of Australia, West Australia, a fine sample of Virginian tobacco which he grew in his small garden in Bramall street, East Perth. The stalk was 3 feet in height, and bore 25 large well-developed leaves. Mr. Frayne planted the seed in October, in pure sand, without any fertiliser, and the stalk referred to was cut four months later.

Times of Sunrise and Sunset at Brisbane, 1908.

| DATE. | MAY. | | JUNE. | | JULY. | | AUGUST. | | PHASES OF THE MOON. |
|-------|--------|-------|--------|-------|--------|-------|---------|-------|----------------------------------|
| | Rises. | Sets. | Rises. | Sets. | Rises. | Sets. | Rises. | Sets. | |
| 1 | 6:14 | 5:16 | 6:30 | 5:0 | 6:39 | 5:4 | 6:30 | 5:18 | 1 May ☉ New Moon 1 33 a.m. |
| 2 | 6:14 | 5:15 | 6:31 | 5:0 | 6:39 | 5:4 | 6:29 | 5:19 | 8 " ☾ First Quarter 9 23 p.m. |
| 3 | 6:15 | 5:15 | 6:31 | 5:0 | 6:39 | 5:4 | 6:29 | 5:19 | 16 " ☉ Full Moon 2 32 " |
| 4 | 6:15 | 5:14 | 6:32 | 5:0 | 6:39 | 5:5 | 6:28 | 5:20 | 23 " ☽ Last Quarter 10 17 a.m. |
| 5 | 6:16 | 5:13 | 6:32 | 5:0 | 6:39 | 5:5 | 6:28 | 5:20 | 30 " ☉ New Moon 1 14 p.m. |
| 6 | 6:16 | 5:12 | 6:33 | 5:0 | 6:39 | 5:5 | 6:27 | 5:21 | |
| 7 | 6:17 | 5:12 | 6:33 | 4:59 | 6:39 | 5:6 | 6:26 | 5:21 | 7 June ☾ First Quarter 2 56 p.m. |
| 8 | 6:17 | 5:11 | 6:33 | 4:59 | 6:39 | 5:6 | 6:25 | 5:22 | 14 " ☉ Full Moon 11 55 " |
| 9 | 6:18 | 5:10 | 6:34 | 4:59 | 6:39 | 5:7 | 6:24 | 5:23 | 21 " ☽ Last Quarter 3 26 " |
| 10 | 6:18 | 5:10 | 6:34 | 4:59 | 6:39 | 5:7 | 6:24 | 5:23 | 29 " ☉ New Moon 2 31 a.m. |
| 11 | 6:19 | 5:9 | 6:35 | 4:59 | 6:39 | 5:7 | 6:23 | 5:23 | |
| 12 | 6:19 | 5:8 | 6:35 | 4:59 | 6:38 | 5:8 | 6:22 | 5:24 | 7 July ☾ First Quarter 6 25 a.m. |
| 13 | 6:20 | 5:8 | 6:36 | 4:59 | 6:38 | 5:8 | 6:21 | 5:24 | 14 " ☉ Full Moon 7 48 " |
| 14 | 6:21 | 5:7 | 6:36 | 4:59 | 6:38 | 5:9 | 6:21 | 5:25 | 20 " ☽ Last Quarter 10 2 p.m. |
| 15 | 6:21 | 5:7 | 6:36 | 4:59 | 6:38 | 5:9 | 6:20 | 5:25 | 28 " ☉ New Moon 5 17 " |
| 16 | 6:22 | 5:6 | 6:37 | 5:0 | 6:37 | 5:10 | 6:19 | 5:26 | |
| 17 | 6:22 | 5:6 | 6:37 | 5:0 | 6:37 | 5:10 | 6:18 | 5:26 | 7 July ☾ First Quarter 6 25 a.m. |
| 18 | 6:23 | 5:5 | 6:37 | 5:0 | 6:37 | 5:11 | 6:17 | 5:27 | 14 " ☉ Full Moon 7 48 " |
| 19 | 6:23 | 5:5 | 6:37 | 5:0 | 6:37 | 5:11 | 6:16 | 5:27 | 20 " ☽ Last Quarter 10 2 p.m. |
| 20 | 6:24 | 5:4 | 6:38 | 5:0 | 6:36 | 5:12 | 6:15 | 5:28 | 28 " ☉ New Moon 5 17 " |
| 21 | 6:25 | 5:4 | 6:38 | 5:1 | 6:36 | 5:12 | 6:14 | 5:28 | |
| 22 | 6:25 | 5:3 | 6:38 | 5:1 | 6:35 | 5:13 | 6:13 | 5:29 | 5 Aug. ☾ First Quarter 7 40 p.m. |
| 23 | 6:26 | 5:3 | 6:38 | 5:1 | 6:35 | 5:13 | 6:12 | 5:29 | 12 " ☉ Full Moon 2 59 " |
| 24 | 6:26 | 5:2 | 6:39 | 5:1 | 6:34 | 5:14 | 6:11 | 5:30 | 19 " ☽ Last Quarter 7 25 a.m. |
| 25 | 6:27 | 5:2 | 6:39 | 5:1 | 6:34 | 5:14 | 6:10 | 5:30 | 27 " ☉ New Moon 8 59 " |
| 26 | 6:28 | 5:1 | 6:39 | 5:2 | 6:34 | 5:15 | 6:9 | 5:31 | |
| 27 | 6:28 | 5:1 | 6:39 | 5:2 | 6:33 | 5:15 | 6:8 | 5:31 | |
| 28 | 6:29 | 5:1 | 6:39 | 5:3 | 6:32 | 5:16 | 6:7 | 5:31 | |
| 29 | 6:29 | 5:1 | 6:39 | 5:3 | 6:32 | 5:17 | 6:6 | 5:32 | |
| 30 | 6:30 | 5:0 | 6:40 | 5:3 | 6:31 | 5:17 | 6:5 | 5:32 | |
| 31 | 6:30 | 5:0 | ... | ... | 6:31 | 5:18 | 6:4 | 5:33 | |

Answers to Correspondents.

POULTRY HOUSE AND YARD.

A BEGINNER, Mooloolah.—For twelve fowls, the house should be 8 feet square, and the yard 50 feet square.

Statistics.

COMMONWEALTH METEOROLOGY.

RAINFALL OF QUEENSLAND.

TABLE SHOWING THE TOTAL RAINFALL FOR EACH MONTH OF THE YEAR IN THE AGRICULTURAL DISTRICTS OF QUEENSLAND.

| STATIONS. | 1907. | | | | | | 1908. | | | | | | |
|-----------------------|-------|-------|------|-------|------|------|-------|-------|-------|-------|--------|-------|-------|
| | June. | July. | Aug. | Sept. | Oct. | Nov. | Dec. | Jan. | Feb. | Mar. | April. | May. | June. |
| <i>North.</i> | | | | | | | | | | | | | |
| Bowen | 2·87 | Nil | 1·28 | 0·51 | 0·06 | 3·71 | 6·39 | 10·14 | 5·63 | 9·46 | 3·73 | 0·99 | 4·5 |
| Cairns | 4·45 | 0·12 | 0·39 | 1·35 | 0·68 | 5·35 | 28·33 | 27·02 | 8·03 | 20·60 | 5·99 | 3·05 | 5·9 |
| Geraldton | 8·54 | 2·39 | 4·66 | 1·36 | 1·42 | 6·45 | 33·82 | 44·39 | 13·27 | 39·00 | 14·23 | 18·52 | 2·64 |
| Herberton | 2·71 | Nil | 0·11 | 0·12 | 0·17 | 3·41 | 9·57 | 9·29 | 5·02 | 8·92 | 1·40 | 0·38 | 3·1 |
| Hughenden | 0·95 | 1·16 | Nil | Nil | 1·66 | 0·66 | 7·75 | 0·98 | 5·18 | 6·91 | 0·30 | ... | 0·5 |
| Kamerunga State Nurs. | 5·29 | 0·13 | 1·15 | 1·19 | 0·53 | 2·76 | 29·82 | ... | 7·17 | 25·75 | 4·60 | 3·363 | 0·76 |
| Mackay | 5·04 | 0·27 | 0·25 | 0·12 | 0·12 | 5·76 | 9·70 | 9·28 | 3·83 | 17·43 | 14·82 | 3·25 | 1·29 |
| Bockhampton | 4·16 | 0·84 | 0·47 | Nil | 0·47 | 3·72 | 4·42 | 3·84 | 9·64 | 9·77 | 2·62 | 0·85 | 0·10 |
| Townsville | 2·38 | Nil | 0·07 | 0·14 | 0·03 | 2·82 | 24·26 | 12·21 | 6·69 | 9·03 | 0·38 | 2·22 | ... |
| <i>South.</i> | | | | | | | | | | | | | |
| Biggenden State Farm | 5·24 | 1·51 | 0·96 | 0·24 | 1·99 | 2·50 | 5·55 | 2·37 | 9·82 | 9·84 | 2·97 | 0·74 | 0·43. |
| Brisbane | 2·91 | 0·39 | 0·79 | 0·10 | 1·37 | 4·25 | 3·21 | 2·80 | 8·43 | 18·19 | 2·45 | 2·40 | 0·17 |
| Bundaberg | 4·49 | 0·87 | 0·43 | Nil | 1·70 | 2·90 | 2·99 | 4·77 | 2·82 | 7·35 | 4·13 | 0·67 | 0·39. |
| Dalby | 2·35 | 0·87 | 0·71 | 0·15 | 0·69 | 5·18 | 1·44 | 0·17 | 4·88 | 7·61 | 0·11 | 0·37 | 0·63. |
| Esk | 2·66 | 0·54 | 0·81 | 0·57 | 0·50 | 3·76 | 3·72 | 2·61 | 10·06 | 17·04 | 2·83 | 1·07 | ... |
| Gatton Agric. College | 1·85 | 0·54 | 0·56 | 0·15 | 0·71 | 3·01 | 4·55 | ... | 3·38 | 10·74 | ... | 0·10 | 0·16. |
| Gindie State Farm ... | 2·29 | 1·58 | 0·10 | 0·16 | 0·61 | 1·57 | 4·42 | 0·20 | 7·17 | 6·25 | 0·02 | 0·112 | ... |
| Gympie | 3·77 | 0·80 | 0·17 | 0·47 | 1·20 | 3·05 | 5·49 | 6·26 | 11·77 | 80·8 | 1·87 | 2·00 | 0·38. |
| Ipswich | 2·22 | 0·30 | 0·43 | 0·05 | 0·78 | 4·45 | 3·40 | 1·32 | 6·63 | 13·77 | 2·71 | 1·14 | 0·12 |
| Maryborough | 6·05 | 0·61 | 0·93 | 0·25 | 2·74 | 3·49 | 5·81 | 5·62 | 8·07 | 11·40 | 2·52 | 1·05 | 0·46 |
| Roma | 2·47 | 1·03 | 0·42 | 0·04 | 1·04 | 3·70 | 2·51 | 0·04 | 6·38 | 2·51 | 0·22 | ... | 0·50. |
| Tewantin | 7·61 | 1·48 | 0·95 | 0·55 | 1·05 | 3·12 | 7·36 | 10·42 | 12·47 | 14·39 | 7·59 | 8·66 | 0·75 |
| Warwick | 1·27 | 1·16 | 1·37 | 0·01 | 1·37 | 3·25 | 3·13 | 0·76 | 4·52 | 6·65 | 1·40 | 0·15 | 0·80 |
| Westbrook State Farm | 2·53 | 1·04 | 1·78 | Nil | 1·08 | 4·76 | 3·23 | 0·43 | 8·03 | 1·41 | 1·40 | 00·5 | ... |
| Yandina | 6·98 | 1·15 | 0·68 | 0·89 | 1·44 | 2·87 | 3·05 | ... | ... | 16·62 | 5·45 | 4·59 | ... |

NOTE.—The rainfall data in this table are compiled from telegraphic reports, and must be considered approximate only.

GEORGE G. BOND,
Divisional Officer.

The Markets.

PRICES FOR FRUIT—ROMA-STREET MARKETS.

| Article. | JUNE. | |
|--|--------------------|--|
| | Prices. | |
| Apples, per case | 7s. 6d. to 12s. | |
| Apples, New England, per packer | ... | |
| Apricots, Local, per packer | ... | |
| Bananas, Fiji, per case | ... | |
| Bananas, Fiji, per bunch | ... | |
| Citrons, per case | 11s. to 11s. 3d. | |
| Cumquats, quarter-case | ... | |
| Custard Apples, per case | 3s. 6d. to 5s. | |
| Gooseberries, per quarter-case | 3s. 6d. to 4s. 9d. | |
| Lemons (Lisbon), per case | 3s. 6d. to 5s. | |
| Lemons, rough, per case | 2s. 6d. to 5s. | |
| Mandarins, per case | 1s. 6d. to 5s. | |
| Oranges, per case | 1s. 6d. to 3s. | |
| Passion Fruit (Local), per case | ... | |
| Papaw Apples, per quarter-case | 1s. to 1s. 6d. | |
| Peaches, per quarter-case | ... | |
| Pears, per case | ... | |
| Persimmons, per case | ... | |
| Pineapples, smooth, per dozen | 1s. to 3s. 6d. | |
| Pineapples, rough, per dozen | 3d. to 1s. | |
| Rosellas, per sugar bag | ... | |
| Strawberries, per tray | ... | |
| Strawberries, per dozen boxes | ... | |
| Tomatoes, per quarter-case | 1s. 6d. to 3s. 6d. | |

SOUTHERN FRUIT MARKET.

| | |
|--|--------------------|
| Apples, local, per bushel case | 9s. |
| Apples, Tasmanian, Eating, per bushel case | 10s. |
| Apples, Tasmanian, Cooking, per bushel case | 6s. to 10s. |
| Bananas, Fiji, per case | 13s. 6d. to 14s. |
| Bananas, Fiji, per bunch | 2s. 6d. to 6s. 6d. |
| Bananas, Queensland, per case | 12s. 6d. |
| Bananas, Queensland, per bunch | 1s. 6d. to 4s. |
| Bananas, Sugar, Queensland, per double case | 10s. |
| Chillies, per bushel | 8s. 6d. |
| Custard Apples, per case | 3s. to 5s. |
| Gooseberries, per quarter-case | 3s. 6d. to 4s. 9d. |
| Loquats, per case | 7s. |
| Mandarins, Emperor, per case | 5s. to 6s. 6d. |
| Mandarins, B.G.R., per case | ... |
| Mandarins, local | 9s. |
| Oranges, Queensland, per case | 3s. 6d. to 4s. 6d. |
| Oranges, Queensland, Navel, per case | 10s. |
| Passion Fruit, per half-case | 4s. 6d. |
| Pears, Victorian, per bushel case | 20s. |
| Pears, Tasmanian, per half-bushel case | 6s. |
| Pineapples, Queens, per dozen | 3s. 6d. to 5s. |
| Pineapples, Queensland (Ripley's), per dozen | 4s. to 4s. 6d. |
| Pineapples, Queensland (smooth), per dozen | ... |
| Pineapples, Queensland, common, choice, per dozen | 3s. to 4s. |
| Pineapples, Queensland, medium, per dozen | 2s. 6d. |
| Strawberries, Queensland, per three-quart tray | 3s. 6d. to 4s. 6d. |
| Tomatoes, per box | ... |

PRICES OF FARM PRODUCE IN THE BRISBANE MARKETS FOR
JULY.

| Article. | | | | | | JULY. | |
|---------------------|-----|-----|-----|-----|-------|----------------------|--|
| | | | | | | Prices. | |
| Bacon, Pineapple... | ... | ... | ... | ... | lb. | 6½d. to 8d. | |
| Bran ... | ... | ... | ... | ... | ton | £7 | |
| Butter, Factory ... | ... | ... | ... | ... | lb. | 1s. 2d. | |
| Chaff, Mixed ... | ... | ... | ... | ... | ton | £3 to £5 10s. | |
| Chaff, Oaten ... | ... | ... | ... | ... | " | £6 10s. to £8 | |
| Chaff, Lucerne ... | ... | ... | ... | ... | " | £6 to £6 10s. | |
| Chaff, Wheaten ... | ... | ... | ... | ... | " | £3 15s. to £4 5s. | |
| Cheese ... | ... | ... | ... | ... | lb. | 8½d. to 9d. | |
| Flour ... | ... | ... | ... | ... | ton | £10 to £10 10s. | |
| Hay, Oaten ... | ... | ... | ... | ... | " | £8 to £8 10s. | |
| Hay, Lucerne ... | ... | ... | ... | ... | " | £3 to £5 10s. | |
| Honey ... | ... | ... | ... | ... | lb. | 3d. to 3½d. | |
| Maize ... | ... | ... | ... | ... | bush. | 4s. 3d. to 4s. 4d. | |
| Oats ... | ... | ... | ... | ... | " | 4s. to 4s. 6d. | |
| Pollard ... | ... | ... | ... | ... | ton | £7 | |
| Potatoes ... | ... | ... | ... | ... | " | £6 10s. to £8 | |
| Potatoes, Sweet ... | ... | ... | ... | ... | " | ... | |
| Pumpkins ... | ... | ... | ... | ... | " | ... | |
| Wheat, Milling ... | ... | ... | ... | ... | bush. | 5s. | |
| Wheat, Chick ... | ... | ... | ... | ... | " | 4s. 9d. to 5s. | |
| Onions ... | ... | ... | ... | ... | ton | £9 to £9 5s. | |
| Hams ... | ... | ... | ... | ... | lb. | 11d. to 1s. | |
| Eggs ... | ... | ... | ... | ... | doz. | 1s. 1d. to 1s. 3d. | |
| Fowls ... | ... | ... | ... | ... | pair | 2s. 3d. to 4s. | |
| Geese ... | ... | ... | ... | ... | " | 5s. 6d. to 6s. | |
| Ducks, English ... | ... | ... | ... | ... | " | 3s. 6d. | |
| Ducks, Muscovy ... | ... | ... | ... | ... | " | 4s. 7d. | |
| Turkeys (Hens) ... | ... | ... | ... | ... | " | 7s. 3d. to 7s. 6d. | |
| Turkeys (Gobblers) | ... | ... | ... | ... | " | 13s. 3d. to 16s. 6d. | |

ENOGGERA SALEYARDS.

| Animal. | | | | | | JUNE. | |
|--------------------|-----|-----|-----|-----|-----|---------------------------|--|
| | | | | | | Prices. | |
| Bullocks ... | ... | ... | ... | ... | ... | £7 2s. 6d. to £9 17s. 6d. | |
| Cows ... | ... | ... | ... | ... | ... | £6 to £7 10s. | |
| Merino Wethers ... | ... | ... | ... | ... | ... | 22s. | |
| C.B. " | ... | ... | ... | ... | ... | 21s. 6d. | |
| Merino Ewes ... | ... | ... | ... | ... | ... | 16s. 9d. | |
| C.B. " | ... | ... | ... | ... | ... | 21s. | |
| Lambs ... | ... | ... | ... | ... | ... | 14s. 9d. | |
| Pigs (Baconers) | ... | ... | ... | ... | ... | ... | |
| " (Porkers) | ... | ... | ... | ... | ... | ... | |

Orchard Notes for September.

By ALBERT H. BENSON, M.R.A.C.

THE SOUTHERN COAST DISTRICTS.

The marketing of citrus fruits in the later districts, of the late winter or early spring crop of pines and bananas, also of strawberries and Cape gooseberries, will continue to occupy the attention of fruit-growers. I can only repeat the advice I have so often given in these notes respecting the marketing of all kinds of fruit—viz., to grade the fruit evenly, pack honestly, and display it to the best advantage if you want to get good returns.

September is a very important month to the fruit-grower, owing to the fact that it is usually a dry month, and that it is essential in all cases to keep the land in a high state of tilth, so as to retain the moisture that is required by the various trees that are in blossom, thus securing a good set of fruit. Where irrigation is available, it is advisable to give the trees a good watering should the ground be dry, as this will induce a good growth and cause the fruit to set well. If an irrigation is given, it should be a thorough one, not a mere surface watering, and once the land is saturated the moisture must be retained in the soil by constant and systematic cultivation. If this is done, one good watering will usually be enough to carry the trees through in good condition to the thunderstorms that come later or even to the summer rains, if the soil is of deep sandy, loamy nature.

No weeds must be allowed in the orchard or vineyard at this time of the year, as they are robbing the trees and plants of both the water and plant food that are so essential to them at this period of their growth.

There is not much to be done in the way of fighting scale insects during the month, as they are more effectually dealt with later on, but where young trees are showing signs of distress owing to the presence of scale insects they should be treated, the gas method being the most efficacious.

Beetles and other leaf-eating insects often make their appearance during the month. The best remedy is to spray the trees or plants with one or other of the arsenical washes that are recommended by me in this Journal. The vineyard will require considerable attention. Not only must it be kept well worked, but any vines that are subject to the attack of black spot must be sprayed from time to time with Bordeaux mixture. Disbudding must be carefully carried out, as this work is equally as important as the winter pruning, as it is the best means of controlling the future shape of the vine. A very common fault with vines grown in the coast districts is that the buds often remain dormant, only the terminal bud and possibly one other starting into growth, thus leaving a long bare space on the main rods, which is undesirable. When this takes place, pinch back those shoots that have started and which are taking the whole of the sap, and force the sap into the dormant buds, thus starting them into growth. This will result in an even growth of wood all over the vine, not a huge cane in one part and either a stunted growth or dormant buds in the rest.

Every care should be taken during the month to prevent the fruit fly from getting an early start. All infested oranges, loquats, kumquats, or other fruits should be gathered and destroyed, as the keeping in check of the early spring crop of flies, when there are only comparatively few to deal with, will materially lessen the subsequent crops.

Land that is to be planted to pines or bananas should be got ready now, though the planting need not be done till October, November, or even later. Prepare the land thoroughly; do not scratch the surface to the depth of a few inches, but plough as deeply as you have good surface soil, and break up the

subsoil as deeply as you can possibly get power to do it. You will find that the extra money expended will be a profitable investment, as it will pay every time.

TROPICAL COAST DISTRICTS.

September is usually a very dry month, and fruit trees of all kinds suffer in consequence. The spring crop of citrus fruits should be harvested by the end of the month, as if allowed to hang later there is a great risk of loss by fly. The fruit should be well sweated, and if carefully selected, well-graded, and well-packed it should carry well to and fetch high prices in the Southern States, as there are no oranges or mandarin grown in Australia that can excel the flavour of the best of the Bowen, Cardwell, Cairns, Port Douglas, or Cooktown fruit.

As soon as the fruit is gathered the trees should be pruned and sprayed with the lime and sulphur wash, as this wash is not only a good insecticide, but it will keep down the growth of all lichens, mosses, &c., to which the trees are very subject.

Every care should be taken to keep down the crop of fruit fly during the month. All infested fruit should be gathered and destroyed, particularly that in or adjacent to banana plantations. Watch the banana gardens carefully, and keep well cultivated. New land should be got ready for planting, and where land is ready planting can take place.

Papaws and granadillas are in good condition now, and if carefully gathered and well-packed in cases only holding one layer of fruit they should carry well to the Southern markets if sent in the cool chamber.

SOUTHERN AND CENTRAL TABLELANDS.

Prune grape vines at Stanthorpe the early part of month, leaving the pruning as late as possible, as the object is to keep the vines back in order to escape damage from late spring pests. All vines subject to the attack of black spot should be treated with the winter dressing when the buds are swelling, this treatment to be followed by spraying with Bordeaux Mixture later on.

Where fruit trees have not received their winter spraying, they should be treated at once before they come out into flower or young growth. Where the orchard or vineyard has not been ploughed, do so, taking care to work the land down fine as soon as it is ploughed, so as to keep the moisture in the soil, as the spring is always the trying time for fruit trees.

Look out for fruit fly in the late oranges and loquats in the Toowoomba district. Keep the orchards and vineyards well cultivated; disbud the vines where sufficiently advanced. Spray for codling moth.

In the Central tablelands irrigate vines and fruit trees, and follow the irrigation with deep, constant, and systematic cultivation. Keep down all weed growth, and fight the red scale on citrus trees with cyanide. The objective of the fruit-grower throughout Queensland during September and the two following months is, "How best to keep the moisture in the soil that is required by the trees, vines, plants, and vegetables," and this objective can only be obtained by irrigation when same is available, or by deep, systematic, and constant cultivation when there is no water available for irrigation.

Farm and Garden Notes for September.

FIELD.—Spring has now arrived, and with it there will be the usual trouble with weeds, especially on carelessly cultivated, uncleaned ground. Therefore the cultivator, the horse and hand hoe must be kept vigorously at work to check the weed pests, save the growing crops, and much future labour. Attend to earthing up any crops which may require it. There may possibly

occur drying winds and dry weather; still, good showers may be looked for in October, and much useful work may be done during the present month, which will afford a fair prospect of a good return for labour.

Plant out *Agave rigida*, var. *sisalana* (sisal hemp plant), in rows 8 feet by 8 feet or 6 by 8 feet apart, according to the richness of the soil. All dry places on the farm, too rocky or poor for ordinary crops, should be planted with this valuable aloe; especially should limestone country be selected for the purpose. If the soil is very poor and the plants very small, it is better to put the latter out into a nursery of good soil, about 1 foot to 18 inches apart. Next year they will be good-sized plants. Keep down tall weeds in the plantation, and do not allow couch grass to grow round the roots. The sisal will do no good if planted in low, wet land, or on a purely sandy soil. It thrives best where there is plenty of lime, potash, and phosphoric acid, all of which can be cheaply supplied if wanting in the soil. Sow cotton, Sea Island near the coast and Uplands generally. Sow maize, sorghum, imphee, mazzagua, prairie grass, panicum, tobacco, and pumpkins. Sugar-cane planting should be vigorously carried on. Plant sweet potatoes, yams, peanuts, arrowroot, turmeric, ginger, and canaigre, the latter a bulb yielding a valuable tanning substance. Plant out coffee.

KITCHEN GARDEN.—Now is the time when the kitchen garden will richly repay all the labour bestowed upon it, for it is the month for sowing most kinds of vegetables. If the soil is not naturally rich, make it so by a liberal application of stable manure and compost; dig or plough the ground deeply, and afterwards keep the surface in good tilth about the crops. Water early in the morning or late in the evening, and stir the soil in the latter case early next day to prevent caking. Mulching with straw or leaves or litter will be of great benefit as the season gets hotter. It is a good thing to apply a little salt to newly dug beds. It is not exactly known what the action of salt is on the soil, but when it is applied as a top-dressing it tends to check rank growth. A little is excellent for cabbages, but too much renders the soil sterile, and causes hardpan to form. French or kidney beans may now be sown in all parts of the State. The lima bean delights in the hottest weather. Sow the dwarf kinds in drills 3 feet apart and 18 inches between the plants, and the climbing sorts 6 feet each way. Sow cucumbers, melons, marrows, and squashes at once. If they are troubled by the beetle, spray with Paris Green or London Purple. In cool districts, peas and even some beetroot may be sown. Set out egg-plants in rows 4 feet apart. Plant out tomatoes $3\frac{1}{2}$ feet each way, and train them to a single stem either on stakes, trellis, or wire netting. Plant out rosellas. Sow mustard and cress, spinach, lettuce, vegetable marrows, custard marrows, parsnips, carrots, eschalots, cabbage, radishes, kohlrabi, &c. These will all prove satisfactory provided the ground is well worked, kept clean, and that water, manure, and, where required, shade are provided.

FLOWER GARDEN.—Continue to plant bulbs as directed last month. Protect the plants as much as possible from cold westerly winds, which may still occur, notwithstanding the increasing temperature. Keep a good lookout for slugs. Plant out chrysanthemums, palms, and all kinds of tropical and semi-tropical plants. If hot weather should ensue after planting, water and shade must be given. Sow dianthus, snapdragon, coleus. Roses will now be in full bloom. Keep them free from aphid, and cut off all spent blooms. This latter work should be done in the case of all flowers. If you wish to save seeds, do not wait for the very last blooms, but allow some of the very best to go to seed. If you have any toads in the garden or bush-house, encourage them to take up their abode there. They are perfectly harmless in spite of their ugliness, and they destroy an astonishing number of insects injurious to plants. Fill up all vacancies with herbaceous plants. Sow zinnia, galliardia, amaranthus, cockscomb, balsam, sunflower, marigold, cosmos, summer chrysanthemum, coreopsis, portulacca, mesembryanthemum, calendula, &c.

Agriculture.

THE AUSTRALASIAN WOOL MARKETS.

From the "Annual Review and Statistics of the Wool Market for the Season 1907-8," published by Messrs. Dalgety and Co., Limited, we extract the following interesting and valuable information:—

As regards forecasting the future of the wool market with certainty, however, it would appear that the faculty is possessed by no one, for the vastly fuller information that is available nowadays and the increased attention paid to the subject by experts, contrasted with past times, only seems to make it become more apparent that all endeavours to foretell the future are more or less labour in vain, and it is not a little hard that when all the known factors are favourable the expected result should be upset by a cause which can neither be controlled nor foreseen.

As regards the conditions which have prevailed in the Australasian selling centres during the past twelve months, it can well be said that never did a season open with brighter prospects and end so disappointingly. It was first expected that the output of wool for the past year would slightly eclipse the record of the previous season, and that the market would rule at a high level and exhibit only minor fluctuations. Prophecy as regards clip production was affected by the setting in of unseasonable weather, winter rains were insufficient, the lambing generally was a poor one, and of spring there was practically none—we moved from a dry winter into an early and hot summer.

The net result of the conditions recorded is that, though the further increase in sheep numbers for the year is 5,075,555, the total clip of the past season (for export) has fallen short of its predecessor by 32,357 bales, the actual output being 2,057,831 bales in 1907-8, as against 2,090,188 in 1906-7. It is of the utmost importance to note that the actual decrease in production is much heavier than statistics given in *bales* indicate. For some years we have drawn attention to the custom, which has continued to grow amongst flockmasters, of putting less and less wool into a bale, and we are pleased to be able to present for the first time statistics as regards production in actual pounds weight, from which it will be seen that the 2,090,188 bales produced during 1906-7 season averaged 339·7 lb., totalling in all 710,168,448 lb., whereas the past year's output (for export) of 2,057,831 bales have averaged but 333·7 lb., or a total of 686,810,010 lb., showing that the actual decrease amounted to 23,350,438 lb. This, at the average weight of 333·7 lb. per bale, gives a total decrease in the past exportable clip of 69,975 bales.

When speaking of wool production for the year, it is also as well to mention that, though the actual amount of clean wool produced is always a matter more or less of surmise, there is no disputing the fact that the past clip from Australasia would not yield, after scouring, anything like so good a percentage as the better grown clip of 1906-7. Supposing the difference in shrinkage between the two clips to be 3 per cent. in favour of the 1906-7 output, it would mean that the amount of actual clean scoured wool produced during the past year (basing the 1906-7 clean washed yield at 47 per cent. on average, and that of 1907-8 at 44 per cent.) has been 31,500,000 lb. less than during the preceding twelve months. We do not think that we will be accused of exaggeration in saying that the past clip would yield clean scoured 3 per cent. less than that of 1906-7, nor for mentioning that the quantity of tops (combed wool) that would be obtainable would show a very much heavier decrease than the figures dealing with actual output of wool show, for the past clip was distinctly disappointing, and will be remembered for the scarcity of good warp wools and the over-abundance of those short-stapled, tender, and burry sorts which give such a very large percentage of noils to top.

The redeeming feature of the clip was its fine quality.

The average of the five years 1901-1905 was only 2'61 lb. per head, but the average of the last two years comes out again at 2'73, or very near the average of the ten years 1891-1900. The figures for last year were, however, quite exceptional.

There will be diminishing supplies, at any rate, during 1908 and 1909, and values should pursue an upward course as soon as confidence is sufficiently restored and the trade realises that the past clip from Australasia shows a shrinkage, and that the next one will do likewise.

That the world's output of gold and wheat have a preponderating influence upon the general prosperity of trade, there is no gainsaying. Upon examining the gold output, it is found that the steady increase recorded on some years almost ceased in 1907, the figures for some recent years being as follows:—

WORLD'S OUTPUT OF GOLD.

| | | | | | | | |
|------|-----|-----|-----|-----|-----|-----|-------------|
| 1904 | ... | ... | ... | ... | ... | ... | £69,818,000 |
| 1905 | ... | ... | ... | ... | ... | ... | 75,682,000 |
| 1906 | ... | ... | ... | ... | ... | ... | 81,844,000 |
| 1907 | ... | ... | ... | ... | ... | ... | 82,298,000 |

The rapid expansion in production from 1904 to 1906 no doubt assisted towards the general prosperity of trade, which developed in 1907 out of proportion to the gold output. . . .

RESULTS TO PRODUCERS.

The 1,351,121 bales which were realised upon in Australasian markets averaged £13 Os. 2d. per bale, and, presuming that that portion of the clip which has been sent direct to London will do likewise, the net gain in wealth from wool production in Australia and New Zealand (for export) for the past twelve months will have been £26,768,952, which, though £2,816,788 less than the preceding year, eclipses that of 1905-6 by £1,507,941, and that of 1904-5 by £6,576,268.

It may be argued that the wool which has been forwarded to London for realisation will not sell at such high prices as the 1,351,121 bales which passed through the local auction rooms, and neither will it; but the average net return to Australasia per bale should be about the same, for, as has been pointed out in previous reviews, most of the wool sent to London for sale is composed of straight lines of the better classes of station clips (mostly fleece) and a much larger percentage of scoureds than is sold in the colonies.

The information tabulated hereunder, covering a period of years, showing number of fleeces per bale and number of bales per 1,000 sheep, demonstrates how many more bales are now filled by the wool from 1,000 head of sheep than was the case, say, ten years ago. The differences noticeable in the present day figures can be set down to two causes, viz.:—

1. Improvement in flocks; and
2. Increased proportion of crossbred wool.

The comparative statement referred to, compiled in accordance with latest sheep returns, is as follows:—

| Year. | No. of Fleeces
per Bale. | No. of Bales per
1,000 Sheep. |
|-----------|-----------------------------|----------------------------------|
| 1896-7 | 59'65 | 16'75 |
| 1897-8 | 60'08 | 16'64 |
| 1898-9 | 59'62 | 16'76 |
| 1899-1900 | 57'95 | 17'25 |
| 1900-1901 | 55'88 | 17'89 |
| 1901-2 | 55'42 | 18'04 |
| 1902-3 | 51'36 | 19'46 |
| 1903-4 | 55'51 | 17'99 |
| 1904-5 | 52'70 | 18'97 |
| 1905-6 | 50'27 | 19'89 |
| 1906-7 | 49'65 | 20'13 |
| 1907-8 | 52'90 | 18'90 |

NOTE.—The greater number of sheep shorn per bale, &c., during last year is attributable to shorter period for growth of fleece already referred to.

Though the pastoral industry has been fairly profitable as regards income from wool, &c., it is regrettable that over the most heavily stocked portions of Australia droughty conditions have prevailed. Fortunately, the almost unheard of drought which had ruled in parts of New Zealand was terminated in the autumn, while the good rains, which fell over most of the drought-infected areas of Australia during May and June, have been concurrent with an appreciation in wool values to the extent of from 12 to 15 per cent. above the very low level to which they had sunk in April and the early weeks of May.

Australasia is so largely dependent upon the pastoral industry for her wealth—wool and kindred products amounting in value to £45,000,000 out of the total exports of £90,000,000—that a drought or heavy decline in wool values is nothing less than a national calamity. It is satisfactory that producers have been so favoured of late years that they were never better able to withstand the, let it be hoped, temporary check to production and lower wool values which have to be recorded. Though the latter has assumed very serious proportions, and can be set down as averaging 30 per cent. as compared with rates current at the opening of the selling season, it must be remembered that values were at a very high level during the first few months of the period under review, and consequently the average value per bale recorded for the whole does not show anything like that decline, notwithstanding that the diminished weight of the bales has operated adversely upon the gross value realised for same.

The position of Australasia to-day is pre-eminently a sound one, and though the immediate returns from pastoral properties are not likely to be so satisfactory as they have been of late years on account principally of lower values, there is every likelihood, given seasonable conditions, of a return to good earnings ere long, for evidence all points to a sure though perhaps slow recovery in wool prices. From a pastoral standpoint, confidence in the position has at no time been shaken, for, concurrently with a fall in prices for station produce, land values have continued to advance.

The weather, as we go to press, is also more seasonable, and, though wool values during the coming year may be low in comparison with recent years, the outlook as regards Australasia's staple industry is not a gloomy one.

American and other buyers know that they must operate in these markets if they want first choice of each year's production, besides which, of course, there is a great saving of freight and time by shipping direct to Boston, &c. During the past twelve months, purchases on U.S.A. account in Australasia, as already mentioned, amounted to 56,571 bales, as compared with 20,000 bales bought for the same destination in London. As stocks of wool in U.S.A. were never lower than at present, and the domestic clip is only equal to supplying half the country's wants, a return of a better feeling in that republic, of which signs are not wanting, should be accentuated by a satisfactory outcome of the Presidential election to be held in November next.

All those buyers who are most intimately known in the Australasian trade are to be sympathised with, for, never mind how assiduously and carefully they performed their heavy duties, nothing has turned out right; wool which they bought cheap one day was dear the next, added to which the past clip was evidently a most deceptive one as regards yield, for most experts acknowledge that they over-estimated same when valuing. They have had the market always against them, and a deceptive and unsatisfactory clip to deal with, with the result that interviews with principals during the past few months have not been anything like so pleasant as they were last year.

A general complaint with manufacturers nowadays is that they are asked to make so many patterns, and often get orders for one suit length of this or that, whereas formerly they sold a larger proportion of standard cloths. The majority of manufacturers hope for a steady wool market at the lower range of values which has of late been established, preferring large supplies on steady markets.

Though the Japanese have taken less wool than in 1906-7, they are likely to compete keenly for good scoured merinos at any time; whilst China, which up till this has not been a customer for Australian wool, will be in the future, for extensive woollen mills have recently been erected at Tientsin and Shanghai. When that vast nation, which slowly but surely is following Japan, wakes up to the advantages of woollen garments, what vast possibilities there will be for extending our trade in the East!

The following table of figures will show how various sections of the trade supported the market. Buyers from the British Isles took 481,543 bales, as compared with 424,000 bales in 1906-7; France, Belgium, and Holland, 415,476, as against about 480,000 last year; Germany, 266,508, as against about 320,000.

The greatest falling off in purchases, however, was on U.S.A.-Canadian account; totals secured for North America being 56,571 bales during 1907-8, as compared with 136,613 bales during the preceding year:—

| | 1907-8. | | 1906-7. | |
|--------------------------|-----------|--------------------------------|-----------|--------------------------------|
| | Bales. | Percentage to Total Purchases. | Bales. | Percentage to Total Purchases. |
| United Kingdom ... | 481,543 | 36% | 424,307 | 28% |
| Continent of Europe ... | 719,560 | 53% | 848,635 | 55% |
| U.S.A. and Canada ... | 56,571 | 4% | 136,613 | 9% |
| Japan, China, India ... | 13,288 | 1% | 37,266 | 2% |
| Local manufacturers, &c. | 80,159 | 6% | 90,977 | 6% |
| | 1,351,121 | | 1,537,798 | |

The highest price for greasy merino fleece in the Australasian markets during the past season was 20½d. per lb., which was obtained in Geelong for DR/Blackwood, 5 bales. In Melbourne, the honour list was topped at 17¾d. for Koolomort, 7 bales; and in Sydney by 17½d. for Cooyal, 4 bales.

Once again by far the larger proportion of the clip has been dealt with in Australasian markets, and again the policy of the majority has proved correct. Taking into consideration that the fall in values acted in the nature of a temptation to ship, it is worthy of note how consistently woolgrowers have supported their own markets in preference to taking risks which on former occasions have proved so disastrous. The pity is that every bale was not sold on this side, for shippers have, indeed, fared badly in London, where realisations so far made have resulted in a loss on the average of about £4 per bale.

Our limited space will not permit of further very interesting information in connection with the wool trade of Australasia and New Zealand; we therefore reluctantly conclude our résumé with a

SUMMARY OF STATISTICS.

Summarising the past year, it is of the utmost importance to note that, after taking into consideration reduced weights of bales, the actual decrease in oversea wool exports from Australasia, as compared with the preceding year, amounts to 69,975 bales, or 23,350,438 lb.

The total amount of the clip available for export has been 686,810,010 lb., as against 710,168,448 lb. in 1906-7 season.

The average value per bale of all the wool sold in Australasia during the past twelve months was £13 0s. 2d., as compared with £14 3s. 11d. for the previous year—a decrease of £1 3s. 9d., or 8·36 per cent.

The tendency on the part of growers to still further reduce the weight of their wool bales, which we referred to twelve months ago, has continued, with the result that the average weight per bale of the past clip has amounted to 333·7 lb., as against 339·7 lb. during the previous season, showing a reduction of 6 lb.

For the twelve months ending 30th June, 1908, 1,351,121 bales sold in Australasia realised £17,577,249; for the same period to 30th June, 1907, 1,537,798 bales grossed £21,835,131. Decrease for the year, £4,257,882.

The total exportable production of Australasia has amounted to 2,057,831 bales, which, if taken at £13 Os. 2d. per bale, shows the value to be £26,768,952. But to the above must be added 80,159 bales which have been manufactured into cloth, &c., in the Commonwealth and Dominion, say £1,042,735 worth. Thus the total production is estimated to have yielded £27,811,687. This is assuming that the wool which has been exported direct to London for sale shows the same net return per bale as has been obtained in colonial centres.

The previous year's exportable surplus of 2,090,188 bales was valued at £29,585,740, so that the exportable surplus of 1907-8 shows a decrease of wealth to Australasia from wool of £2,816,788.

By dividing the total number of sheep depasturing in the Commonwealth and New Zealand—viz., 108,871,681—into the net weight of wool produced, including that used for local manufacturers—viz., 713,567,068 lb.—it will be seen that the average weight of wool produced per head works out at 6 lb. 9 oz., which compares with 7 lb. 2 oz. in 1906-7. The average monetary return has been 5s. 1d. per head of sheep and lambs, as against 5s. 11d. for the previous season; the falling off in weight of wool produced per head and the lesser monetary return being attributable to the facts that a large proportion of the sheep had but ten to eleven months' growth of wool on when they were shorn, poorer general condition of the last clip, and lower average of values ruling than in 1906-7.

The quantity of lambs' wool dealt with in Australasia during the past twelve months amounts to 70,980 bales, as compared with 105,873 bales for the season 1906-7, a decrease of 34,893 bales.

The proportion of lambs to fleece sold was 5 per cent., as compared with 7 per cent. the previous year, the declining percentage being due to the poorer lambing of the past season.

The proportion of scoured wool sold in Australasian markets has been but 9 per cent., as compared with 11 per cent. during the previous year.

The number of sheep in Australasia at 31st December last amounted to 108,871,681, an increase of 5,075,555 as compared with corresponding date in 1906.

The total slaughterings of sheep and lambs for local consumption and export combined were 17,059,780 during the year 1907, which compares with 15,637,087 during 1906.

VALUE OF AUSTRALASIAN CLIP.

As showing the vastly preponderating influence of the wool clip upon the prosperity or otherwise of Australasia, the following figures, taken from the official Year Books of the Commonwealth and New Zealand, giving comparison of values of wool shipments with total exports (January-December period), are of great interest and use, viz. :—

| | Total Value
Exports. | Total Value
Wool Exports. | Percentage
of Wool
to Whole. |
|----------|-------------------------|------------------------------|------------------------------------|
| 1881 ... | £48,728,240 | £16,136,082 | 33·11 |
| 1891 ... | 72,705,247 | 24,063,227 | 33·09 |
| 1896 ... | 66,545,374 | 20,433,855 | 30·77 |
| 1901 ... | 62,386,632 | 18,936,557 | 30·35 |
| 1902 ... | 57,413,686 | 16,109,026 | 28·05 |
| 1903 ... | 63,088,304 | 18,042,873 | 28·59 |
| 1904 ... | 72,087,702 | 21,796,096 | 30·23 |
| 1905 ... | 72,344,565 | 25,203,549 | 34·83 |
| 1906 ... | 87,578,109 | 29,411,424 | 33·58 |
| 1907 ... | 92,975,271 | 35,267,851 | 37·93 |

ON THE SELECTION OF PHOSPHATES.

On the above subject, we have received the following notes from their author:—

It is not necessary to state that phosphate of lime is essential for the improvement of grass land and the production of large and healthy crops of turnips and swedes. The farmer's difficulty is to select the particular kind of phosphatic fertiliser that is best adapted to his particular kind of soil. Until the last few years it seemed to be taken for granted that superphosphate or dissolved bones should be considered the most suitable phosphates for spring application, irrespective of the character of the soil. But the wonderful results that have followed the judicious application of basic slag on coarse pasture and heavy clay has afforded a very striking and very practical illustration that one kind of manure is not suitable for all kinds of soils, and that there are conditions under which a hard fused mass possessing an alkaline character, and but little soluble in ordinary water, if finely ground, is capable of producing better results than was formerly obtained from the use of a very soluble but acid manure. The very general manner in which all kinds of manures appear to be forced upon the farmer's notice adds very considerably to his difficulty in making a selection. It would certainly be a convenience if the merits of any particular fertiliser were put forth by the sellers in a modified and somewhat restricted manner, that fertilisers should not be described as suitable for all soils and all crops, but rather for certain soils and certain crops. If this were done, the future results would be more satisfactory to sellers and buyers. Farmers would know what to buy, and would not be disappointed with the results, while sellers would soon find out the districts where their manures gave the best results, and their sales would be greatly increased. With a view of assisting in the selection during the coming season, the following remarks are offered in regard to the three principal kinds of phosphate fertilisers and the particular soils for which they are respectively adapted:—

SUPERPHOSPHATE

supplies phosphate of lime in the most soluble form that can be obtained, and is specially suitable for all good arable soils containing plenty of lime. When carefully manufactured from high-class mineral phosphates, the percentage of phosphate of lime rendered soluble in water, and, therefore, readily available, varies from 25 per cent. to 35 per cent., and where carriage is costly the higher quality will be found to be the most economical. In order, however, to get the full benefit from this valuable fertiliser, it is absolutely necessary that the soil should contain plenty of lime—at least 5 per cent.—because the acid phosphate, which is harmful to vegetation, requires to be neutralised by the alkali lime, and rendered alkaline before it can be absorbed by the minute rootlets of the plant. A shrewd Jersey farmer once told us that he always selected a dry day for top-dressing his clover seeds, because he found that in damp weather, or when there was a heavy dew, the clover leaves were blistered and scorched by the acid nature of the superphosphate. Anyone can soon see the injurious effect of throwing superphosphate over the leaves of plants, and the minute rootlets are still more sensitive. The superior value of water-soluble phosphate of lime is due to the fact that its great solubility promotes more perfect and extended diffusion through the soil, and not, as is sometimes supposed, to the direct absorption by the rootlets of the acid phosphate of lime. Pure dissolved bones are superior to superphosphate, because they supply nitrogenous organic matter, in addition to phosphate of lime; but hitherto manufacturers, out of deference to the farmers' desire to see the bones in the manure, have not carried the dissolving process with sulphuric acid sufficiently far to render the bones completely soluble, as the term "dissolved bones" would naturally lead us to conclude was the case. Consequently, as most of the phosphate of lime and nitrogen compounds still remain in an insoluble form,

such so-called dissolved bones are naturally more suitable for soils somewhat deficient in lime rather than for soils which abound in lime.

BASIC SLAG (THOMAS' PHOSPHATE),

when first introduced as a fertiliser, about the year 1883, was little appreciated by scientific men of high authority, on account of its origin as a hard, fused, refuse rock-like material from the iron-ore blast furnaces, and its little solubility—only about 6 parts being dissolved by 100 parts of ordinary water. Farmers, however, in the Midland counties were induced to take small quantities for trial, chiefly on their old grass land, and as the results on certain soils, rich in vegetable matter but poor in lime, were satisfactory, scientific authorities were obliged to admit its agricultural value as a fertiliser on certain soils. It is important to recognise the fact that basic slag is only suitable for certain kinds of land, such as damp heavy clay, deficient in lime, but containing plenty of acid vegetable matter, which, in the presence of moisture, rapidly decomposes the powdered slag, and liberates lime as well as phosphoric acid in a condition readily available for plant food. It is a mistake to recommend basic slag as being suitable for all soils; farmers know that its application, though most beneficial to certain land, has failed to produce any beneficial results upon other kinds of land. It is more economical to adapt the manure to the soil rather than to adapt, or try to adapt, the soil to the manure. Basic slag varies in its contents of phosphate of lime from 30 per cent. to 40 per cent., and sometimes 45 per cent., and lime from 40 per cent. to 50 per cent., also in the fineness of the grinding, so that it is necessary to stipulate for a guarantee as to its chemical composition and mechanical condition, for the grinding should be such that 80 per cent. to 90 per cent. should pass through a sieve of 10,000 holes to the square inch. It has been stated that this material contains as much as 20 per cent. of free caustic lime, but this is not the case, because any such quantity would indicate a wasteful method of manufacture, for lime is only added in sufficient quantity to remove the phosphorus and silica originally present in the iron ore. The actual amount of free caustic lime in ordinary slag does not exceed 3 per cent. to 4 per cent., and its mild alkaline character, as compared with quicklime, can easily be ascertained by putting equal quantities of these materials into tumblers of cold water and testing the solution after standing and stirring for a few minutes. Most of the lime is present in a combined form, such as phosphate of lime and basic silicate of lime, from which latter compound it derives the name of basic slag. In order to dissolve such compounds, it is requisite that the soil water should be acid, for, as already pointed out, ordinary water has but a very slight dissolving effect upon such a hard fused mass, however finely ground the powder may be. It will be gathered from the foregoing remarks that basic slag, though a most useful manure, can only be profitably applied to certain kinds of soil.

BASIC SUPERPHOSPHATE

consists of superphosphate which has been made alkaline by the admixture of finely-ground or lightly slaked lime in sufficient quantity to convert the original mono-calcic or water-soluble phosphate into di-calcic, or citric-soluble phosphate, with a slight excess of caustic lime. This fertiliser was introduced in the spring of 1901, and is manufactured by a syndicate consisting of ten of the largest firms in England, Scotland, and Ireland, so that there should be no difficulty in obtaining it anywhere. The material has a white appearance, and is in a very light, powdery state, occupying fully two and a-half times the space of slag, and, when sown broadcast by hand, does not fall between the fingers before delivery, as in the case of slag. It contains about 35 per cent. of lime and 26 per cent. of phosphate of lime, which, though not soluble in water, is readily soluble in a very weak solution of citric acid,

containing 1 part of citric acid in 1,000 parts of water, which represents an acidity less than that possessed by the acid juices of the rootlets of plants, so that all the phosphate of lime so dissolved may be fairly regarded as available plant food. It combines the valuable alkaline character of basic slag with the well-known solubility of superphosphate, but is free from the defects of these opposite manures—namely, the comparative insolubility of slag and the injurious acidity of superphosphate. If 1 part respectively of basic superphosphate and basic slag are separately exhausted with 1,000 parts of weak citric acid solution (1 in 1,000) for twenty-four hours, with occasional stirring, it will be found that 90 per cent. of the former has been dissolved, compared with 40 per cent. of the latter. The new manure is intended to occupy an intermediate position between acid superphosphate and alkaline slag, and to be applied for intermediate descriptions of soil. It is not intended to supersede the use of superphosphate upon good arable land containing plenty of lime, nor is it intended to take the place of well-ground slag upon sour grass land, damp, heavy clay or rich vegetable soils; but it is specially intended for soils deficient in lime, such as light clay, gravel, granite, and sandy soils, the united acreage of which represents such a large proportion of the cultivated area of the United Kingdom. It has been found particularly useful for turnips when sown on land subject to finger-and-toe, and should be drilled with the seed at the rate of 5 cwt. per acre. On this point, interesting details will be found in Dr. Voelcker's report of experiments with turnips on soil subject to finger-and-toe at Woburn, published in the Royal Agricultural Society's journals for 1905 and 1906. It is hoped that farmers will derive some assistance from the above remarks in selecting for the coming season the particular kind of phosphatic fertiliser which is best adapted to their particular soil.

JOHN HUGHES,
Agricultural Analyst for Herefordshire.

Analytical Laboratory,
79. Mark lane, London E.C.

THE AGRICULTURAL COLLEGE AND STATE FARMS' EXHIBITS AT THE EXHIBITION.

Although the District Exhibits from the Lockyer, New England, and the Central Districts embrace a greater variety of industries than is possible in the case of the College and State Farms, yet the latter must be considered amongst the most interesting and attractive courts at the late Exhibition at Bowen Park, and they deservedly attracted crowds of appreciative visitors. The art of arranging a court and the exhibits is one demanding a long apprenticeship; and the managers of the State institutions named, which also include the Kamerunga State Nursery at Cairns, have exhibited so often during the past ten years that they have become past masters in the art of displaying the various products of the soil in the most attractive manner, and not less in describing with infinite patience, day and night, the methods by which the splendid results have been achieved. Taking the Departmental exhibits right through, it cannot but be said that master minds directed the laying-out of the courts, which were full of interest and instruction, not only to agriculturists, pastoralists, horticulturists, and all primary producers, but also to scientists, and to those who are now arriving in considerable numbers from the Southern States and from Europe with the view of settling amongst us as farmers and graziers or of investing capital in some of the many profitable industries which the vast resources of the State present to them.

We do not propose to go into the various details of the courts, as that work is ably done by the hundreds of newspapers which circulate through the



AGRICULTURAL COLLEGE AND STATE FARM COURTS AT THE NATIONAL ASSOCIATION'S EXHIBITION, AUGUST, 1908.

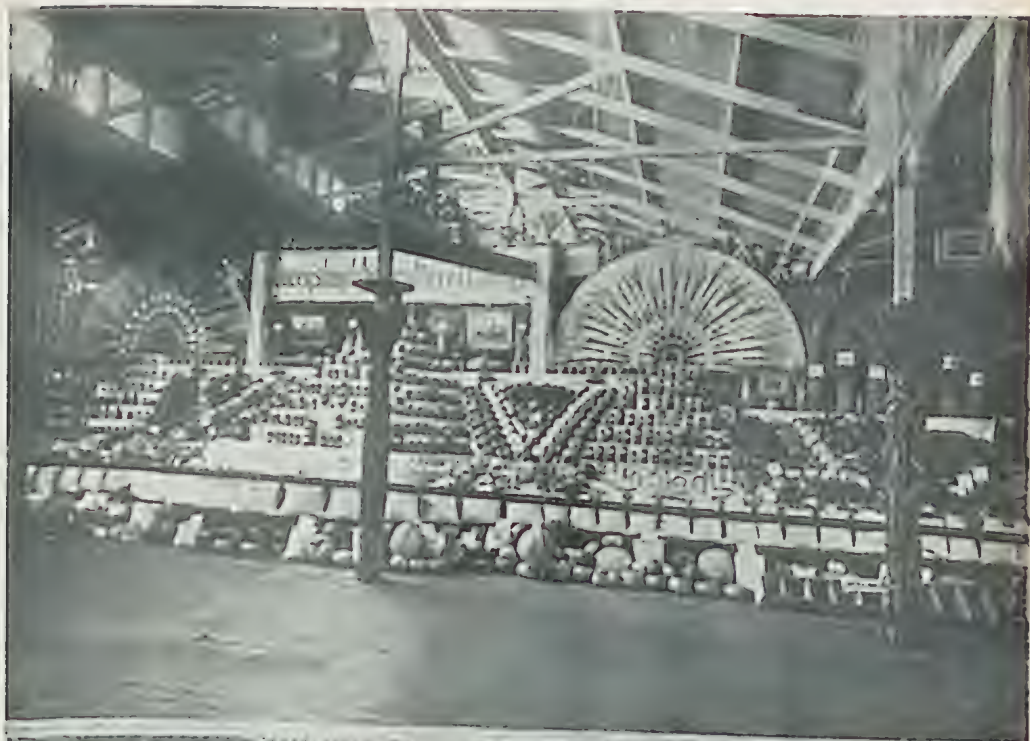

1. EXHIBITS OF THE QUEENSLAND AGRICULTURAL COLLEGE.
2. EXHIBITS OF THE WESTBROOK AND HERMITAGE STATE FARMS.

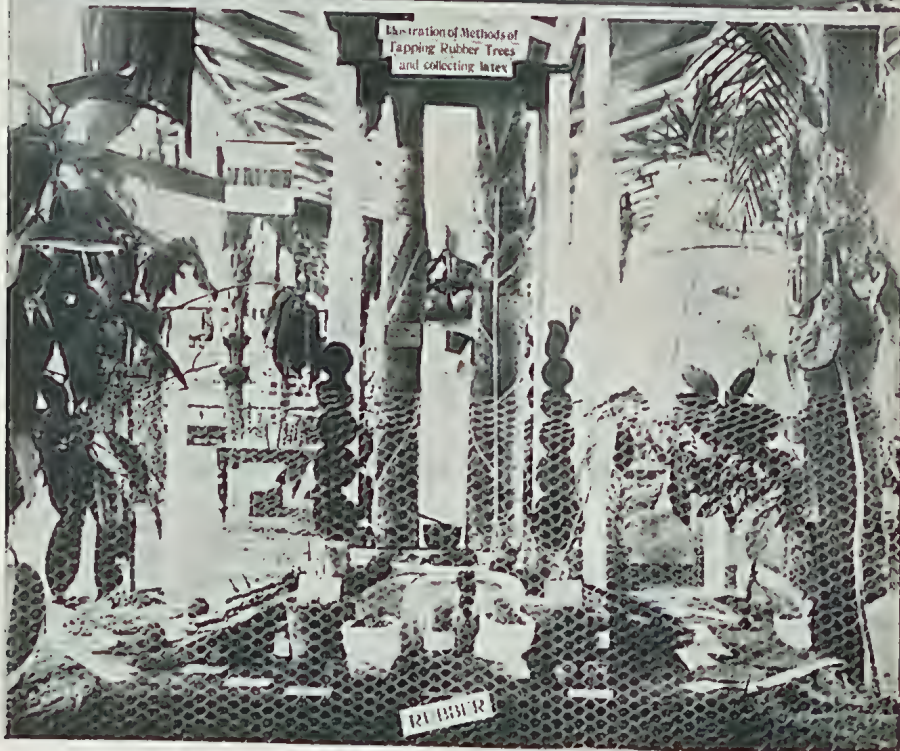
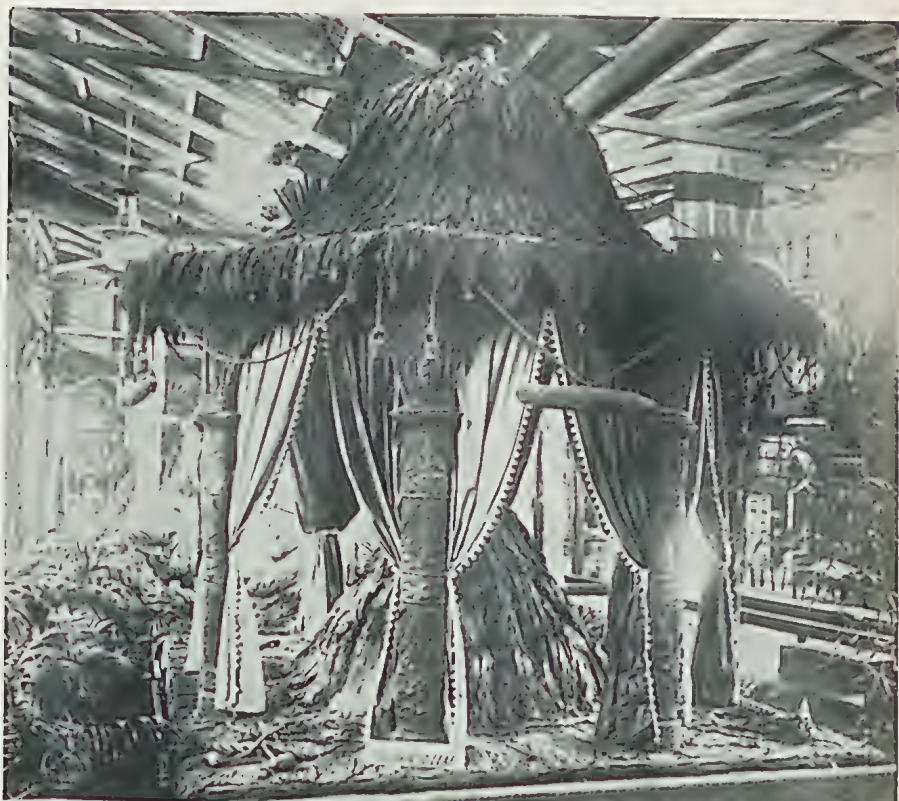

1. TOBACCO TROPHY IN THE STATE FARMS COURT.
2. RUBBER EXHIBIT FROM KAMERUNGA STATE NURSERY.

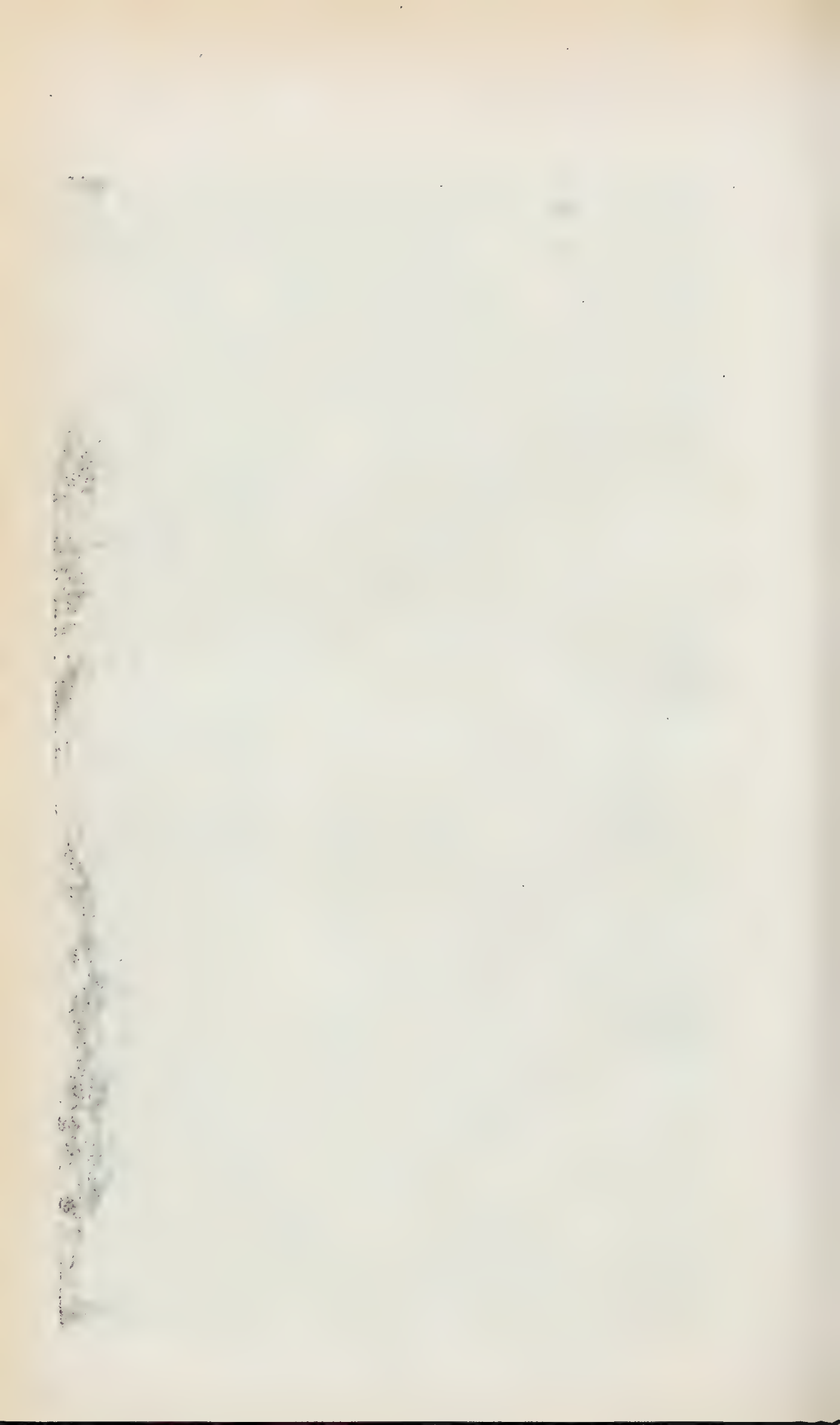



SISAL HEMP EXHIBIT, GROWN AND MANUFACTURED AT H.M. PENAL ESTABLISHMENT, ST. HELENA.

Plate XXIV.



EXHIBIT OF RAW AND MANUFACTURED SISAL HEMP, GROWN AT FARNBRO'S, CHILDERS, BY T. H. WELLS, ESQ.



1. EXHIBITS FROM THE KAMERUNGA STATE NURSERY, CAIRNS.

2. THE CENTRAL DISTRICTS. (The First Prize was awarded to this Court at the National Association's Exhibition, August, 1908.)

whole State, even to its remotest confines, and which are doubtless read by all who receive this Journal. We should, however, mention a unique exhibit which appeared for the first time at the late Exhibition—that is, the sisal hemp exhibited, on a commercial scale, in the form of marketable bales, coils of rope, binder twine, and other forms in which the fibre is prepared for the market, by Mr. T. H. Wells, of Farnbro', Childers. That gentleman has entered largely upon the cultivation of the sisal plant, and has imported the best machinery for treating it. He has encountered many difficulties in bringing his plantation to the manufacturing point, and, as he says, "It pays." This exhibit deservedly took first prize. In the Departmental court there was a beautiful trophy of fibre from St. Helena, and also a most artistic temple or kiosk made entirely of tobacco leaf. The pillars, with Corinthian capitals, the flutings, architraves, and, in fact, everything architectural, were twisted out of tobacco leaf, whilst the beauty of the structure was enhanced by gracefully-looped curtains (the work of a lady, by the way), and at night it was illuminated by a chandelier of electric light.

We were genuinely pleased to note that the District Exhibit from Central Queensland carried off first honours this year, but what does not please us is to see the apathy or want of patriotism of some districts which could show an infinite variety of products peculiar to their part of the State. From Torres Strait to Cape Byron, from the coast to the far West, an infinite variety of raw and manufactured products, which only exist in certain localities, could be shown. It no doubt entails great expense, and, what is more to the point, great personal exertion, to get together a large district exhibit; but it should be always borne in mind that such exhibits not only advertise the State, but they put forward, by ocular demonstration, the claims of the districts as desirable places for settlement, their claims for railways, harbour improvements roads, bridges, &c., &c., and these means of advertising portions of the State are far more potent than scores of deputations. We must not omit to mention one remarkable exhibit, also appearing for the first time in the section occupied by the Kamerunga State Nursery—that is, the rubber exhibit. Here it was to be seen in all stages of growth (old age excepted, of course), from the seed to the tapping of the tree to obtain the latex. It was an object lesson which needed no lecturer. Mr. Newport had so excellently arranged the exhibit that he might have placarded it "A Silent Lesson in Rubber Production," as did Mr. C. Ross, of Westbrook State Farm, when he exhibited the art of vine-pruning, and labelled it "A Silent Lesson in Pruning Vines." We hope that next year there will be several more districts competing for the coveted honour of "nulli secundus." It is remarkable that on one single day of the Exhibition one-tenth of the adult population of the State was present on the grounds

BRITISH APPRECIATION OF THE JOURNAL.

Since the inception of the "Queensland Agricultural Journal" in July, 1897, the editor has always endeavoured to carry out the objects for which it was established, and which were duly set forth in the first issue; and, judging by the appreciation of it not only by Queensland farmers, cane-growers, orchardists, dairy farmers, &c., but by farmers in many other parts of the world, it would appear that the Journal meets with general approval.

Some little time ago a request was received by the Queensland Department of Agriculture from the South-eastern Agricultural College at Wye, Kent (Eng.), for copies of the "Queensland Agricultural Journal," which they required to complete their files. A letter has now been received from the librarian of the college acknowledging receipt of the copies, and stating that in his opinion it is the best "Agricultural Journal" they receive from any of the colonies.

Dairying.

THE DAIRY HERD, QUEENSLAND AGRICULTURAL COLLEGE, GATTON.

RECORD OF COWS FOR MONTH OF JULY, 1908.

| Number. | Cow's Name. | Breed. | Date of Calving. | Total Milk. | Average Test, Per cent. | Commer-
cial
Butter. | Remarks. |
|---------|----------------|--------------------|------------------|-------------|-------------------------|----------------------------|------------|
| | | | | Lb. | | Lb. | |
| 1 | Peewee ... | Holstein-Sh'rth'm | 20 May, 1908 | 1,044 | 3·6 | 42·09 | |
| 2 | Grace ... | Shorthorn ... | 30 May " | 1,000 | 3·4 | 38·04 | |
| 3 | Sue ... | Grade Shorthorn | 25 May " | 930 | 3·4 | 35·41 | |
| 4 | Lady Loch... | Ayrshire ... | 20 June " | 633 | 3·8 | 26·93 | First calf |
| 5 | Hetty ... | Ayrshire-Sh'rth'n | 25 Mar. " | 443 | 5·0 | 25·81 | |
| 6 | Lark ... | Ayrshire ... | 6 June " | 554 | 4·0 | 24·81 | First calf |
| 7 | Nettle ... | Shorthorn ... | 14 May " | 622 | 3·4 | 23·68 | |
| 8 | Carrie ... | Jersey ... | 25 Mar., 1907 | 566 | 3·6 | 22·82 | |
| 9 | Lubra ... | Grade Jersey ... | 5 June, 1908 | 561 | 3·6 | 22·61 | First calf |
| 10 | Damsel ... | Holstein ... | 19 Feb. " | 434 | 4·4 | 21·38 | |
| 11 | Honeycomb | Shorthorn ... | 23 Aug., 1907 | 275 | 6·4 | 19·71 | |
| 12 | Mona ... | Holstein-Sh'rth'n | 20 Oct. " | 423 | 4·0 | 18·95 | |
| 13 | Madge ... | Grade Holstein ... | 16 June, 1908 | 478 | 3·4 | 18·20 | |
| 14 | Rhoda ... | Shorthorn ... | 27 Mar. " | 449 | 3·6 | 18·10 | |
| 15 | Nancy ... | " ... | 7 May " | 526 | 3·0 | 17·67 | First calf |
| 16 | Glen ... | " ... | 10 Feb. " | 357 | 4·4 | 17·59 | |
| 17 | Nellie II. ... | " ... | 25 Dec. " | 424 | 3·5 | 16·62 | |
| 18 | Lily ... | Ayrshire ... | 2 May " | 499 | 2·8 | 15·65 | |
| 19 | Cocoa ... | Jersey ... | 20 Nov., 1907 | 325 | 4·1 | 14·92 | |
| 20 | No. 112 ... | Grade Jersey ... | 19 April " | 246 | 5·4 | 14·88 | |
| 21 | Lucy II. ... | Shorthorn ... | 1 May, 1908 | 371 | 3·5 | 14·54 | |
| 22 | Graceful ... | " ... | 25 Feb. " | 260 | 4·8 | 13·98 | |
| 23 | Maggie ... | Grade Holstein... | 11 May, 1907 | 289 | 4·2 | 13·59 | |
| 24 | Beauty ... | Ayrshire ... | 20 Dec. " | 322 | 3·7 | 13·34 | |

BAIL AND GATE FOR MILKING-SHED.

Last year we illustrated and described a handy bail and gate for milking-sheds, which was designed, constructed, and worked by Mr. David Alcorn, of Springbank, Mutdapilly. During show week a gentleman from Maryborough—Mr. C. H. Clayton—informed us that he had built his bails in accordance with Mr. Alcorn's directions. He says it is the most perfect system he ever tried. There is not the slightest trouble with the cows. As soon as they are milked, instead of having to turn round or back out, they simply walk through the bail and get at once to their own yard. We have been asked to reprint the article and diagram for the benefit of other dairymen.

The advantages claimed for these appliances are:—

1. A child can operate them in perfect safety from the rear.
2. A saving in time—no backing up or turning round—the cow walks straight through the bail, which draws back both at the top and bottom; simultaneously the gate moves back an equal distance. Two steps, and the cow is in the grass paddock.
3. The gate and bail-stick adjust themselves for the next customer—the gate, by running back into its place in front of the bail; and the bottom end of bail-stick flying back to its place when the hand of the operator is removed.
4. Crowding milked and unmilked cows together is thus entirely obviated, and the risk of ripping, tearing, and swearing is non-existent.
5. The bail and gate are easily constructed by any handy man.

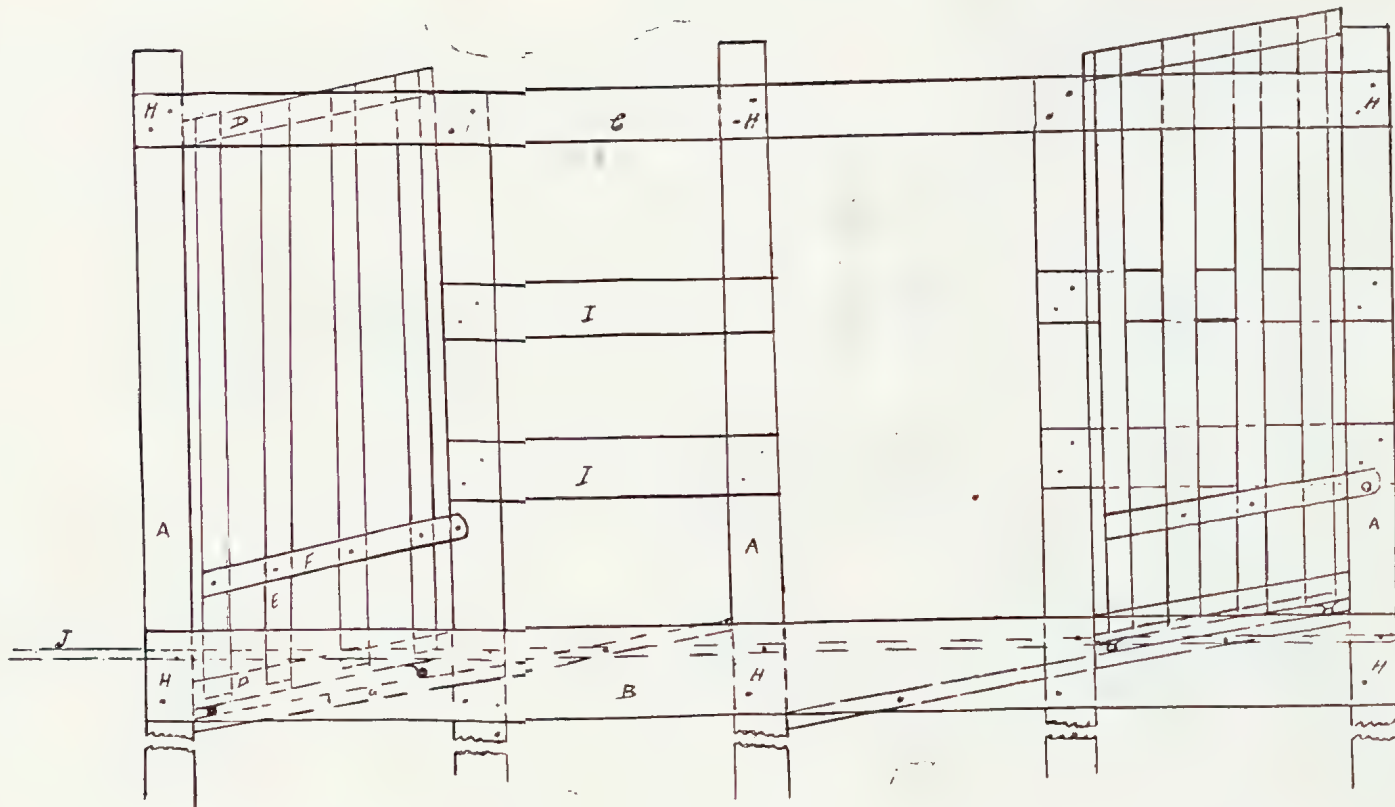

Section No 1

Section No 2

Section No 3

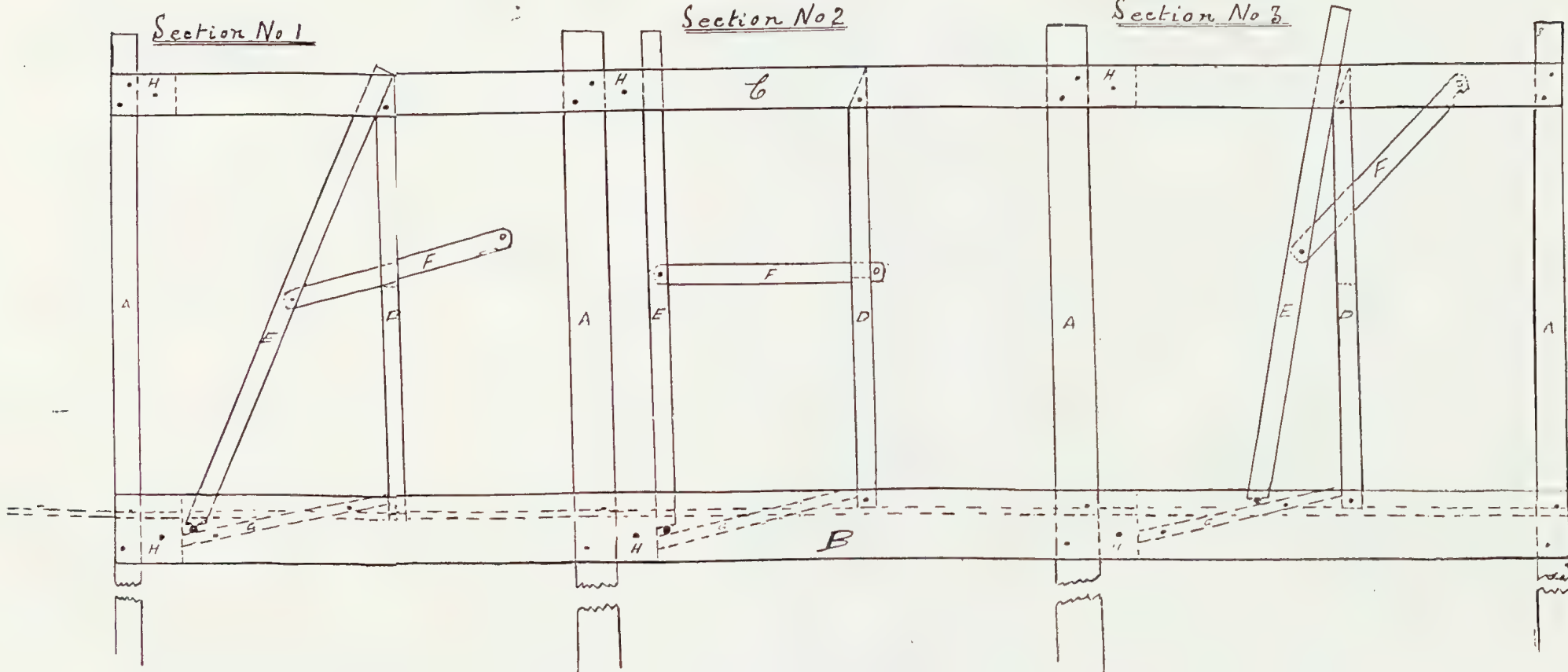

IMPROVED COW-BAIL AND GATE.

SPECIFICATIONS OF BAIL AND GATE AS PER ATTACHED TRACING.

Bail.—This is shown on the tracing in three sections—1, 2, and 3. Section 1 shows the bail open to receive the cow. Section 2 shows the bail closed, and how it is held in that position. Section 3 shows the bail open at both top and bottom, to allow the cow to go out.

Construction.—The whole is constructed of hardwood timber, bolted together, as shown on the plan.

Posts.—A represents the posts on which the bail is built, and may be either round or sawn timber. If sawn, the corners next the cow's neck should be rounded, and may be of any size considered substantial enough for the purpose. These will be sunk into the ground about 2 feet, standing 6 feet 6 inches out of the ground, and 6 feet wide apart from centre to centre. The posts to be bolted to the rail that divides one bail from the other.

Planks.—Hardwood planks, 10 inches by 1 inch, marked B on the plan, are let into the posts already mentioned, leaving a space of $2\frac{1}{4}$ inches between, and securely bolted level with ground, as shown.

C.—Hardwood planks, 6 inches by 1 inch, let into both sides of the posts 6 inches from the top, leaving a space of $2\frac{1}{4}$ inches as in the case of the bottom planks, and bolted.

Posts.—A 3-inch by 3-inch hardwood post (D) is fixed 3 feet from the bail post, between the top and bottom planks, and bolted as shown. This post has a long mortice to allow the bail catch to move upwards easily; the top end is shaped as shown.

Bail-stick.—The bail-stick (E) is of hardwood, 3 inches by 2 inches, 6 feet 3 inches long, having a long-shaped mortice near the centre, about 2 inches deep, to receive the end of the bail-catch. The bottom end to be cut on an angle, and fitted with a small wheel.

Bail-catch.—A hardwood batten (F), 3 inches by $\frac{3}{4}$ -inch, is fixed to the bail-stick with a bolt, leaving sufficient room to work easily. The other end to have a notch near the end to catch in post (D) at the mortice, holding the bail-stick securely in place.

Inclined Bottom.—A piece of hardwood (G), $2\frac{1}{4}$ inches by 2 inches, is fixed between the bottom planks extending from the block marked H to the bottom of the post marked D, with a fall from right to left of 6 inches. This piece will form an inclined bottom to the $2\frac{1}{4}$ -inch space above mentioned between the planks, and bolted through as shown.

Blocks.—H represents blocks of hardwood, $2\frac{1}{4}$ inches thick, 6 inches wide, and 10 inches long for the bottom, and 6 inches long for the top, put in position between the planks and bolted. The block at the bottom is meant for the bottom end of the bail-stick to bump on, and the upper one to prevent the bail-stick closing too tightly on the cow's neck.

Concrete Line.—I represents the concrete line, $2\frac{1}{2}$ inches from the upper edge of the bottom planks.

Gate.—This is shown in two sections—section 1 shows the gate closed, and section 2 shows it open.

Posts.—A represents the posts forming the side of the yard or shed, sunk in the ground to a sufficient depth to suit the purpose, and standing out at least 6 feet 6 inches. The insides, or bail sides, of these posts are faced so as to give an even line on which to fix the planks. The main posts will be put in 6 feet apart from centre to centre. Another post, also faced, is put in 2 feet 6 inches away from the post on the left, and just as high as the top edge of the top planks.

Planks.—B represents hardwood planks, 10 inches by 1 inch, fixed as follows:—The first plank is placed in position along the faced posts at the ground, and well spiked or bolted thereto. Then block H, being $2\frac{1}{4}$ inches

thick, 10 inches long, and as wide as the post the other way, is spiked to the planks already fixed; then the second plank is put in position and spiked or bolted. This will leave a space of $2\frac{1}{4}$ inches in which the gate will run.

Top Planks.—The top planks (C) are put on 6 inches from the top of the main post in every particular as the bottom ones. The first planks put on, both at bottom and top, are spiked at the centre post; heads of spikes or bolts to be countersunk, so that the gate may work between the planks with freedom.

D represents the bottom and top rails of the gate, and is of hardwood, 3 inches by 2 inches, morticed as shown for 4 3-inch by 1-inch bars. These mortices to be made on an angle, so that when the gate is in position the bars will be plumb.

E represents bars of the gate pegged top and bottom, the bottom rail to be supplied with two small wheels, about 2 inches in diameter, held in position by iron fasteners countersunk.

F is a 3-inch by 1-inch piece bolted to the bars of the gate on the inside.

A piece of hardwood (G), $2\frac{1}{4}$ inches by 2 inches, is fixed in space between planks and bolted as shown, with a fall from right to left of 10 inches; this forms an inclined bottom on which the gate runs.

H.—Blocks put in where shown on plan, and already described when fixing planks.

I.—Two rails fixed to inside of centre on right-hand posts to close this space; these are of 6-inch by 1-inch hardwood, spiked on.

J.—Line of concrete, $2\frac{1}{2}$ inches from the upper edge of the plank.

K.—The distance between the gate and the bail will be 20 inches, to allow room for the cow's head.

All posts and rails dividing one bail from the other may be made of round timber.

[Mr. Clayton said that the total cash outlay on his bails amounted to 18s. for timber and 5s. for bolts.]

RESULTS OF MILKING COMPETITIONS AT THE NATIONAL ASSOCIATION'S EXHIBITION.

National Champion Butter Fat Test, special prize of £25, presented by the Brisbane Newspaper Company, to be won three times by the same exhibitor, cow (any breed) giving the best butter fat results in forty-eight hours under the Babcock test, and which has been the property of the exhibitor three months before the date of entry. (Mr. E. Burton's Stumpy secured the first "leg in" last year.)—P. Biddles' Mary II.

Cow yielding the largest quantity of butter fat in forty-eight hours (Babcock tester). The test milkings took place at 7 a.m. and 5 p.m. on Wednesday and Thursday, 12th and 13th August, the date of calving being taken into consideration. First prize, £5; second, £3; third, £1 10s. (£2 2s. was presented by E. Sachs and Co.). P. Biddles' Mary II., calved 15th April, 1908; milk, 77 lb. 12 oz.; butter test, 3'898; commercial butter, 4'317; points for age, 69; lactation, 15½; total, 84½. W. F. Hammel's Trilby, calved 9th February, 1908; milk, 95 lb. 11 oz.; butter test, 3'378; commercial butter, 3'684; points for age, 59; lactation, 24; total, 83'2. S. Holmes's Florrie, calved 12th July, 1908; milk, 117 lb. 7 oz.; butter test, 3'855; commercial butter, 4'173; points for age, 66; lactation, nil; total, 66'3. E. Burton's Stumpy, 63¾ points, 4; E. Burton's Silver Belle, 53, 5; E. Burton's Lady Kirkham and Pussy's Pride, each 52'6.

Special prize of £2 2s., presented by Messrs. Elliott Bros., Limited.—P. Biddles' Mary II.

Special prize of £5 5s., presented by the proprietors of "Sydney Mail," for the best milch cow, any breed, subject to a test, and yielding the largest quantity of commercial butter in forty-eight hours.—P. Biddles' Mary II.

Special prize, £3 3s., presented by the Silverwood Dairy Factory Company, Limited, Brisbane, for the cow (any breed) yielding the largest amount of butter fat in four milkings.—P. Biddles' Mary II.

Cow yielding largest supply of milk in forty-eight hours, subject to result from Babcock tester, of not less than 3 per cent. of butter fat. The test milkings took place at 7 a.m. and 5 p.m. on Wednesday and Thursday, 12th and 13th August. First prize, £5; second, £3; third, £1 10s., of which £5 5s. was presented by the Nestle's and Anglo-Swiss Condensed Milk Company, Crossbrook, and £2 2s. by Mr. R. Tudor.—S. Holmes' Florrie, 117 lb. 7 oz., 1; W. F. Hammel's Trilby, 95 lb. 11 oz., 2; P. Biddles' Mary II., 77 lb. 12 oz., 3.

Special prize, £2 2s., presented by Mr. Peter Comino, conditions same as preceding class.—S. Holmes' Florrie.

TABLE OF RESULTS.

The following are the details of the tests as supplied by Mr. R. W. Winks (Government Dairy Expert):—

WEDNESDAY'S MILKING.

| | Name of Cow. | Lb. of Milk. | Test. | Butter Fat. | Lb. Commercial Butter. |
|----------|----------------------|--------------|-------|-------------|------------------------|
| MORNING. | Pussy's Pride | 15.5 | 3.3 | .505 | .518 |
| | Mary II. | 17.14 | 4.3 | .768 | .851 |
| | Florrie | 27.5 | 3. | .819 | .883 |
| | Trilby | 24.14 | 3.6 | .895 | .980 |
| | Lady Kirkham | 17.8 | 3.6 | .630 | .689 |
| | Silver Belle | 20.2 | 3.2 | .644 | .698 |
| | Stumpy | 20.15 | 3.1 | .649 | .702 |
| EVENING. | Pussy's Pride | 16.10 | 4.1 | .681 | .748 |
| | Mary II. | 16.8 | 4. | .660 | .736 |
| | Florrie | 29.14 | 3.2 | .956 | 1.03 |
| | Trilby | 2.31 | 3.4 | .784 | .853 |
| | Lady Kirkham | 14.5 | 4.8 | .687 | .765 |
| | Silver Belle | 18.12 | 4. | .750 | .826 |
| | Stumpy | 20.10 | 4.8 | .990 | 1.10 |

THURSDAY'S MILKING.

| | | | | | |
|----------|----------------------|-------------|-----|------|------|
| MORNING. | Pussy's Pride | 13lb. 15oz. | 3.4 | .469 | .511 |
| | Mary II. | 20.11 | 4.1 | 1.25 | 1.38 |
| | Florrie | 29.11 | 3.2 | 9.50 | 1.03 |
| | Trilby | 23.6 | 3.2 | .748 | .811 |
| | Lady Kirkham | 13.14 | 4.3 | .596 | .660 |
| | Silver Belle | 18.13 | 4.1 | .771 | .852 |
| | Stumpy | 19.3 | 4. | .767 | .846 |
| EVENING. | Pussy's Pride | 13.5 | 3.7 | .492 | .539 |
| | Mary II. | 22.11 | 5.4 | 1.22 | 1.36 |
| | Florrie | 30.9 | 3.7 | 1.13 | 1.23 |
| | Trilby | 24.6 | 3.9 | .951 | 1.04 |
| | Lady Kirkham | 13.14 | 4.2 | .582 | .643 |
| | Silver Belle | 18.3 | 4.7 | .854 | .951 |
| | Stumpy | 16.7 | 3.6 | .591 | .647 |

WEIGHTS OF THE COWS.

The cows were weighed by Mr. E. A. Pickering on Monday for record purposes. The weights were as follow:—Florrie, 10 cwt. 2 qr.; Stumpy, 8 cwt. 3 qr.; Silver Bell, 7 cwt. 3 qr. 7 lb.; Lady Kirkham, 7 cwt. 2 qr. 14 lb.; Pussy's Pride, 6 cwt. 1 qr. 21 lb.; Trilby, 9 cwt. 1 qr. 21 lb.; Ruby, 7 cwt. 3 qr. 14 lb.

ANGORA GOATS.

As the interest in the mohair industry appears to be increasing in Queensland, we revert once more to the subject, although actually since December, 1899, no less than forty-four articles on the subject have appeared in this Journal. For the benefit of new settlers, however, we again consider the industry.

To begin with, we believe that there are no absolutely pure Angoras (females) in the country. At one time, pure Angoras could be imported from Turkey, but since 1881 the export of Angoras from that country has been forbidden, although, as a matter of fact, a few piastres judiciously bestowed have in some instances unlocked the door to American buyers. Be that as it may, the Angora in Queensland is the result of crossing and recrossing until the real type of Angora has eventuated.

STARTING A FLOCK.

In building up a grade flock, the males must not be allowed to grow into bucks of breeding age, and in no case should any but a thoroughbred sire be used. These, it is stated, can be got from £5 5s. to £15 15s. each. If a few purebred does can be purchased at the same time to mate with this buck, some good young bucks can be obtained to put to work later on. A remarkable feature about the thoroughbred Angora bucks is the rapidity with which they impart their distinguishing qualities to their progeny. It takes three or four crosses, commencing with common does, to produce a grade animal which can barely be distinguished from the thoroughbred at a short distance, and which produces a mohair fleece weighing from 3 lb. to 5 lb. of a good average quality.

The common does should be entirely white, any other colour is objectionable. Other desirable qualities are small head, short, smooth hair, and small horns. Objectionable features are long, coarse hair on the thighs and fore legs below the shoulders. The common does are very prolific, and can be obtained at a moderate figure. Always pick does with the shortest and finest hair. The short hair in mohair is known as "kemp," and the shorter you can get it the more valuable will be your clip. The buck should be as free from "kemp" as possible, so when selecting handle him carefully and look for the short, thick hairs that lie close to the skin; the less he has of them the better. Does crossed with a good buck will produce first grade, from which the best does can be selected, and so with careful management a flock of high quality can be built up. The young grade bucks should be converted into mutton. They make the best of mutton, and their skins are valuable for mats or rugs until the flock has been so bred up that it will pay to clip.

As to the age for breeding: Goats reach maturity when about sixteen or eighteen months old. If bred earlier, the kids will be undersized and partially developed.

Kids should not be weaned until they are four and a-half months old, when they are very strong, but should not remain with their dams after they are five months old. Buck kids not reserved for breeding purposes should be castrated when about two weeks old.

The kidding time is the most important time in the life of goats. For two or three days after the kids are dropped they are exceedingly delicate. They cannot rough it at this period, but will die from any little exposure and neglect. They are more delicate for a few weeks than lambs, but when large enough to follow the flock their constitutions are stronger, and they are well able to look after themselves. It is useless trying to rear Angoras unless you provide a small paddock for kidding and keep the bucks and wethers out, and leave them as undisturbed as possible. The Americans go so far as to yard them at kidding time. As for climate, no place has been found that is too hot or too cold for Angoras. Though not partial to heat, they will stand it quite as long as sheep. Shade is essential to success if the sunshine is very hot. In considering

Angora culturé it is of more importance to study the climate with reference to moisture than temperature. Therefore, low lands with much moisture are not recommended. As a drought-resister the Angora has in Australia completely eclipsed the merinos, and also beats them easily in the matter of yield and in scouring tests. A fair average yield for greasy merino fleeces is 45 per cent., while similarly for greasy Angora fleece 65 per cent. is a fair average yield. In America there are about 300,000 Angoras, and the industry is a very thriving one. Cape Colony, in 1900, had 4,000,000 Angoras, and exported £450,000 worth of mohair. There can be no reason why Angoras should not do equally as well in Queensland.

GOATS AS LAND CLEANERS.

As land cleaners goats have no equal. They are constantly at work, and it is wonderful how they will convert dense undergrowth into rich grazing land. We have any quantity of suitable land in the State that would benefit by being cleaned up by flocks of goats, and at the same time the owner would not only have his country improved but would have a clip of mohair and good mutton as well. So far, little in this way has been done out here, but in the United States they have done wonderfully good work. One writer says:—"The work they have done is beyond my expectations, and what has been said about their efficiency as brush or land cleaners that I have read or heard of has not been withdrawn." Another writer says that "in the Hawaiian Islands they are being used to eradicate the lantana"; if they are successful in keeping down this pest, our farmers on the North Coast line should try to experiment, and I have no doubt a great amount of good would result.

CARE AND MANAGEMENT.

As with all domestic animals, to get best results they require good care. Generally speaking, they are hardy, and thrive well as far north as Alaska, and in the extreme heat of Guadalupe Island, so there is no reason why they should not do exceptionally well here, so long as the owner uses ordinary common sense in managing them. They will breed at five and six months old, but it is far better to allow them to come to maturity, and not to breed from them until they are twelve or fourteen months old. They are in their prime from two to nine years, and have been known to breed up to fifteen years. Old goats produce mohair of a coarser quality, which consequently is of less value than younger goats. The age is determined the same as sheep.

NOT LIABLE TO DISEASE.

Goats are less subject to disease than other animals, but when you notice a weak one in the flock be careful to isolate it for a few weeks until it regains its strength. The stronger goats are given to bunting the weaker, and they get down and are trampled to death.

BREEDING.

It is generally agreed that in-and-in breeding produces the finest quality of mohair, having all the beautiful lustre and little oil, but then you must bear in mind you are reducing the size and constitution of the animals. The period of gestation in goats is 150 days, and care should be taken to mate them so that the kids are dropped in the warm months, as they are delicate for the first few days. It is not an uncommon thing for does to produce twins, but the higher the standard of your goats the less twins are produced. The average percentage of kids in large flocks is about 70 per cent., but with small flocks and care you should have 95 per cent. to 100 per cent. At kidding time the does should be kept at home and in small areas, as they are given to roaming in the larger areas, and lose their kids. Goats require plenty of fresh air, so it is unwise to crowd them in small yards with shelter-sheds that do not give them plenty of room. Good fleeced goats require dry sheds rather than warm ones. In close quarters they are given to bunting, but do little harm.

SHEARING.

Shearing should not be delayed until the goats begin to shed, as the mohair loses its lustre, the skin itches, and every effort is made to get rid of the fleece. You can use your own judgment about shearing twice a year. It is allowed you get a little more in weight, but as against that your length of mohair is less, and the price falls accordingly. Shearing machines are the best to use, and goat-owners find it to their advantage to use them. The fleeces should be kept as clean as possible, carefully rolled and never tied with string, as manufacturers complain sorely about this practice. Dalgety and Co., Sydney or Brisbane, will be pleased to handle what mohair you have got for sale.

MOHAIR.

Mohair is the technical name for the fleece of the Angora goat; it is a hair pure and simple, and differs from wool, as it has not the felting properties of that product. The fleece of a good Angora goat should be pure white and exceeding lustrous, attain an average length of 8 to 10 inches, and should hang in wavy curls or ringlets from all parts of the body. It is a fact known to practical breeders that goats have two coats of hair; the outer and more abundant is the mohair, and the under coat a coarse, chalky white, straight, stiff hair, which varies from $\frac{1}{2}$ -inch to $\frac{1}{4}$ inches. This under hair is known as kemp, and is believed to be a relic of the common goat blood, and, as pointed out previously, this is what all breeders should try and breed out as much as possible. It reduces the value of your mohair, and is objectionable to the manufacturer; and why? Simply because it will not take the dyes used for mohair; the only effect of the dye is slightly to discolour the kemp. There are dyes which act upon kemp, but they have no effect on the mohair, and no dye up to the present has been found to act satisfactorily upon both. There is a use for kemp and short mohair, as I have before stated. It is used principally in the manufacture of a cheaper class of goods; and fillings for carpets, &c.

RECORD PRICE.

The record price for Australian mohair is 4s. 2d. per lb. This price was lately realised by Blaxland and Knox, of New South Wales, for a fleece from their imported buck Perfection. The fleece, weighing 9 lb. 8 oz., and the skirted portion 6 lb., was forwarded to a New York merchant, who paid 1 dollar (4s. 2d.) per lb., leaving a net return of £1 0s. 2d.

THE DEMAND FOR MOHAIR.

The demand for mohair is good, and there is every probability of an increasing demand, as new uses may be developed. "The American Wool and Cotton Reporter" states that with an increased production of Angora goats in this country, and the consequently enlarged introduction of mohair, the latter is going to be consumed more largely than heretofore, and is, indeed, already "cutting more of a figure in the wool market."

The great beauty of mohair is the lustre, which remains in the manufactured article, and no amount of washing or dye will remove it; in fact, it aids the dyes to show their colours more effectively, and, however much exposed, they will not fade.

Angoras in some countries are shorn twice a year; the yield, of course, as with sheep, depends on the quality of goats you are grading up. I should think shearing once a year sufficient in this State; it is all a matter of management on the part of the producer. If his goats are good and showing 8 to 9 inches of hair, it might be preferable to clip twice in the year, so as to prevent the hair matting.

ANGORA MUTTON.

It may seem strange to many in a country like this, where sheep are so plentiful, that this point should be touched on, but during my visit to Townsville show last year I saw as fine a lot of grade Angora lambs, bred by Mr. J. R. Chisholm, as anyone would wish to see. He exhibited them alive, and had a number of them killed, dressed, and hung up amongst a number of crossbred lambs. I venture to say 99 out of every 100 persons who saw them could not pick out the Angoras. They dressed beautifully, and were sold to a leading butcher, who supplied them to some of the best people in the city, and I guarantee they never tasted anything better. He also told me that he bought them regularly at 12s. 6d. each, and there was a good market for them. Of course, goat meat is always associated with prejudice of the common "ill-smelling Billy," but anyone who knows anything about Angoras will tell you they are free from goat odour, and their meat is totally different from that of the common garden variety of goat; it is finer, carries more fat, is smaller in the bone, and more like merino lamb than anything else. In parts where sheep will not thrive, no man need be without good mutton if he keeps a few Angoras. The does are not equal as milkers to the common goat, but many good milkers are to be seen in various flocks; their milk is very rich, and many writers state that it is more nearly equivalent to human milk than that of any other animal. It is an old saying but a true one, "that a goat will thrive where a sheep will starve," and, further, goats are thriving in districts where cattle are dying of redwater and ticks, and it is a rare thing to find a cattle tick on them.

JUDGING BREEDS OF CATTLE.

At the last Maryborough show considerable surprise was evinced at the action of the judge, Mr. James Stewart, in refusing to judge the class entered as "Durhams" as such. The point on which Mr. Stewart based his decision was that the Durham is an ox, and essentially a beef breed, and that those exhibited were Illawarra Milking Shorthorns, and a very excellent type of the class. Still, they were crossbreeds of the Ayrshire and Durham, and, therefore, could not possibly come under the classification of pure Durhams. It is held, and rightly so, to be a mistaken idea that Milking Shorthorns are Durhams, and Mr. Stewart and other judges are of opinion that the sooner this delusion is expunged from the minds of the people the better it will be for all concerned. In any future judging, unless the pure Durham is exhibited, he will never pass crossbreeds for the former, although this has been done on several occasions. When this matter was discussed between the stewards and exhibitors at the show, both parties, we are told, unanimously agreed with Mr. Stewart's proposition, and the judging proceeded on the above lines. This decision will doubtless be of interest to show committees and cattle breeders.

The Shorthorn sprang from the Teeswater, true, but the old Teeswater was more a dairy cow than the latter-day Shorthorn, the reason being that our ancestors of those days were improvident, never fed their cattle or cared for them, requiring nothing but the milk, and hence they did not develop into beef-producers. On this matter of descent it may be mentioned that the old Durham or Teeswater cattle were known in England from the earliest historical period as beef cattle, although, as stated, neglect and improvidence resulted in the beef type not becoming so pronounced as subsequently under better conditions. The Shorthorn is a descendant of the breed, and for many generations has established certain characteristics which attracted the attention of the most noted breeders, such as Bates, Booth, and Cruickshank, who became celebrated for the excellence of their animals, and it may safely be said that to-day the Shorthorn stands pre-eminent for its beef-producing qualities throughout the civilised world.

Last year Mr. Stewart attended the Royal Show at Lincoln, England, and noted that Shorthorns were sold at very high prices. One bull brought 1,000 guineas at public auction. He was, however, much disappointed at the English and Scotch so-called Milking Shorthorns, as they seemed more like bullocks than dairy cattle, and altogether lacked the propensities of deep milkers, and it also struck him that their term of lactation would be a short one. After visiting a great many herds in England and Scotland, he was most impressed with the Lincoln Red Shorthorn as a dairy animal, and consequently purchased several for breeders in this State. These animals, we understand, are giving entire satisfaction to their owners.

THE MILK TRADE—QUALITY OF MILK.

So many vendors of milk have been lately fined in this State, owing to the alleged—and, in most cases, clearly proved—adulteration of the milk by added water, that anything which may tend to exonerate innocent dairy farmers from the charge cannot fail to be of great interest, and especially so any evidence which would tend to show that the time of year and the feed have considerable effect in reducing the percentage of butter fat. A writer in the British "Live Stock Journal" says:—

The subject of milk contracts is one which needs the serious consideration of the dairy farmer, for the tying nature of many which are constructed by milk buyers is very great, and it is almost impossible for the producer to carry them out to the letter.

The chief clause is that as to quality; and whilst most milk buyers are content to accept milk "guaranteed pure, with all its cream," numbers specify the percentage of fat that it must contain, or below which richness it must not fall. In many instances the figure is unduly high, and in one case coming under notice of the writer the milk had to contain not less than 3·75 per cent. of fat, an altogether excessive percentage, and one which it is doubtful if any farmer could keep up to unless having Jersey, Guernsey, or other special breed of cows noted for the richness of their milk.

The more common requirement is 3·25 per cent., but even this quality is frequently not attained by the majority of milk producers at certain periods of the year.

Now, whilst the purchaser stipulates that this quality must be reached, if not exceeded, a proviso is made that, if it falls below the figure specified, a deduction of $\frac{1}{4}$ d., $\frac{1}{2}$ d., or some other amount per gallon shall be made.

From considerable experience in testing milk from mixed herds and individual cows, the writer is assured of the difficulties, feed in what manner you will, of producing milk even up to the Government's standard—viz., 3 per cent. of fat—at certain periods of the year. Taking the different months of the year, April is undoubtedly the one in which the poorest milk is produced, and the mixed milk from numberless farms tests down so low as 2·6, 2·7, 2·8, 2·9, and 3 per cent. of fat only, though it generally meets the Government requirements as far as solids non-fat are concerned, which are 8·5 per cent.

It is about the end of March, April, and early part of May that such numerous prosecutions take place for adulterated milk, and, unfortunately, where the letter of the law is enforced a great number of innocent persons are convicted and fined for adulteration, the magistrate being ignorant of cows and of their peculiar capacity of yielding milk below the fixed standard of quality.

The effect of food in improving the richness of milk is, unfortunately, very slight, and, whilst something can be done in the case of a herd yielding poor milk, it is but little.

Provided a cow is well fed—that is, getting all the food necessary for the support of her body and for the manufacturing of the particular quantity of milk she is giving—extra food then has little or no effect in improving quality. It is a cow in poor condition, which is badly fed, that will respond to good feeding, and in such cases an improvement in the quality of milk is obtained.

Again, a change of food helps to improve the quality a little; as just in the same way human beings get tired of one particular diet served every day, so a cow served with fresh food yields a rather better milk, but the change is, as a rule, only temporary.

Poor milk is largely due to the cow itself—"breed," as it is usually designated—and whilst there are many cows in the herd always yielding poor milk, there are others yielding rich, so that when all is mixed together a fair average test is obtained. It is at times of maximum flow, spring season of the year and other climatic influences, that the poor quality of mixed milk is most noted.

Thus it is wise for farmers to be cautious in signing contracts to avoid as much as possible harsh restrictions which milk buyers would have the power to enforce.

A give-and-take policy is necessary, for, whilst milk is very poor at certain times of the year, on the other hand it is very rich in autumn, when the cows are not yielding so much. Further, no farmer should be responsible for milk after it has been delivered into the hands of the dairyman. For samples taken on the milk round, the vendor should be wholly responsible.

ANGORA FLOCKS IN QUEENSLAND.

The following gentlemen own considerable numbers of Angoras in this State:—

Messrs. H. Missing, Tiaro, near Maryborough; H. Philp, Grantham; G. H. Simpson, Torrington, Toowoomba; J. M. Doherty, Gayndah; J. R. Chisholm, the Prairie, North Queensland. Besides these, there are several owners of from half a dozen Angoras and upwards.

In South Australia the most notable breeder is Mr. E. A. Scammell; in New South Wales, Mr. R. Blaxland; in Western Australia, Mr. J. D. Rankin; the latter gentleman last year obtained 3s. per lb. for his mohair, clear of all expenses. He reckons 15 lb. mohair to be a fair annual clip from one goat.

PRICKLY PEAR AND RABBITS.

Killing two birds with one stone is profitable, and Mr. Herbert Paul, the inventor of the pneumatic cane-cutting implement, has suggested to us a plan by which the pear could be eradicated and a good trade be done in rabbits. His idea is not to fence the rabbits *out*, but to fence them in. In prickly pear country, where there are numerous rabbits, enclose a large area with a rabbit-proof fence. When all other means of subsistence have vanished, the rabbits would be compelled to live on the pear, and when that has been destroyed thousands of rabbits could be obtained for export. It is a good idea, but we do not recollect seeing rabbits in country densely covered with the pear.

The Horse.

SPEED AND STAMINA OF THE WELSH PONY.

The recent importation by Mr. John Mahon, Principal of the Queensland Agricultural College, of the Welsh pony sire Ich dien, will give an interest to the following notes on these ponies by Mr. J. Jones, of Dinarth Hall Pony Stud, Colwyn Bay. Writing to the "Live Stock Journal," Mr. Jones says:—

We have read with interest the various articles in your recent issues, and noted the varying statements and comparisons as to the stamina of the Hackney and the American harness horse, but it is questionable whether for endurance and stamina either can vie with the Welsh cob or pony. The stamina and endurance of the Welsh cob and pony are proverbial to those who have had experience of them, and, even when mingled with alien blood, their Welsh characteristics are outstanding.

We have in our possession to-day a pony mare, well known in Wales as Nance or Glyn, standing 13 h. 1½ in., foaled in 1891. She was bred by the late Mr. Jenkin Jenkins, of Blaenplwyf, Cardiganshire, and we purchased her from his executors. Her dam and all her ancestors were pure Welsh, but her sire was the thoroughbred Rameses. This pony commenced her racing career as a two-year-old. She has never received any orthodox training, for the whole of her life she has wintered out—not in the fashionable paddock, with its accompanying expensive forage, but on the highest peaks—in all weathers, and with only Nature's own feeding. She has often raced direct off the field, and on many occasions won three races in an afternoon, these varying from 1½ to 3 miles each. Her category includes flat-racing and steeple-chasing over the roughest of country, and more than often competing without any limit of height. Her opponents have included clean thoroughbreds, hunters, and a fair average of the ordinary race-meeting animal.

From 1893 to 1903 Nance or Glyn competed in 268 races, winning 184 firsts, 60 seconds, 16 thirds, and only eight times unplaced. Since then her record has not been so minutely kept, still she has won a very large proportion of the races in which she has started, her latest achievement being on 6th May, this year, when seventeen years old, and only one week off grass, she won two races of 2 miles each. Both events came within half and hour of each other. Her opponents included, we believe, three of the fastest Galloways in Wales.

We think we can safely throw down the gauntlet to any breed to produce an animal whose achievements are so marked and extend over such a period, and who is to-day (at seventeen years old) probably fit to hold her own with at least any pony of her own size on flat or cross-country over a distance of 3 miles or upwards.

NOVEL METHOD OF TEACHING A HORSE TO TROT.

Crabstick, a son of the mare One Eye, by a son of Messenger out of a daughter of Messenger, was such a confirmed pacer and so ill-tempered that his owner despaired of teaching him to trot. A Mr. Ebenezer Pray, of New York, succeeded, after a long struggle and many falls, in making him renounce the "one side at a time" gait. He planted on the side of the road rails and stakes at intervals of a good trotting stride, and tried to make Crabstick trot over them. The horse began by throwing Mr. Pray, but he remounted, and at length managed to get Crabstick to face this novel course. After he had gone over it once or twice, the interval between the rails was increased, and then the horse was put over them again and again until both he and his rider were exhausted. Wilful and hard to manage as he was, Crabstick would always trot afterwards when required to do so.

Horticulture.

FLOWER GARDENING, No. 8.

By THE EDITOR.

PLANTS SUITABLE FOR OUTDOOR CULTURE.

LILIES.

Lilies, as a rule, do not figure largely in suburban gardens, yet most of them will grow in almost any ordinary garden soil; a good, rich, loamy will suit them, but some prefer a soil of loose sandy texture, as, for instance, the beautiful *Lilium auratum*. The Golden Lily of Japan thrives best in a soil composed of equal parts of loam and peat, with sand added.

A point to bear in mind in cultivating lilies is to disturb them as little as possible; it is sufficient to add a top-dressing of soil annually. If it be absolutely necessary to transplant any, care should be taken that this be done at the proper season, as soon as the stems have died down. The ground for lilies should be trenched of 2 feet, and be well manured; plant the bulbs 6 inches deep and 6 inches apart, leaving more space for the larger kinds, and water freely during the growing season. The best months to plant lilies are from March to June. Animal manure should not be dug in with the bulbs, and, if used, it ought to be completely decayed and placed at some distance from the bulbs. Lilies may be allowed to remain in the same spot for years, but, if it is found necessary to lift them, they should be immediately replanted, as the roots are continually in motion, and quickly make a new growth.

When planting in beds, the most effective way is to plant them in groups of three to nine bulbs in a mass. The plants must not be exposed to a hot sun, and, therefore, require to be shaded by some means. Dry hot soil will impoverish the bulbs and prevent increase, and to benefit these it is necessary to cover the beds with a thin covering of straw litter or peat fibre.

Of two species of more modern introduction, *Lilium auratum* is the most magnificent. This is the Golden-rayed Lily of Japan. The elegant Chinese Trumpet Lily makes a valuable spring and winter decorative plant, as it has immense flowers of snow-like purity.

A STORY OF CHINESE LILIES.

The "Californian Cultivator" prints a curious legend of the origin of the species of narcissus known as Chinese lily; it is as follows:—

Very few people who see and admire the beautiful Chinese lilies know the reason why this particular flower is held in such favour in the Orient. This is the story of the origin, as told by a Chinaman:—

Years and years ago a member of the celestial empire had two wives whom he loved dearly because each had borne him a son. While they were still lads the father died, and, in settling up the estate some difficulty was encountered, for the man left his heirs two pieces of land, one a strip lying in a fertile and beautiful valley, the other a small ribbon of land bordering the bed of a narrow stream. The former land was known to grow anything the country produced, while the latter was counted utterly worthless.

It was at first proposed that each of the two strips be divided in half, and a section of each be given to the two heirs. But the mothers could not agree upon the division, and it was finally arranged that one son should take the rich land, while the other should take the sterile piece.

The valley strip yielded bountiful harvests season after season, and the rocky one gave nothing until one day the boy owner happened to notice a tiny

white sweet-scented flower blooming among the rocks, and after a careful study and examination it was found to be the only one of its kind in China. The flower grew from a bulb, and the boy discovered that these bulbs could be transplanted to similar rock soil without destroying their growth.

Soon the bulbs were in great demand, and when it was learned that the flowers brought good luck to the owner of the plant the boy had all he could do to supply the market. From the sale of the bulbs he grew enormously wealthy, while his brother never made more than a good living out of his valuable valley property.

Many of the species thrive well in pots. As potting is a very important operation, I shall, later on, devote some space to the subject.

SOME GOOD VARIETIES.

Tigrinum (single and double Tiger Lily); *Speciosum (lancifolium) rubum*, white, spotted with crimson; *Speciosum (lancifolium) album*, pure white; *S. (l.) roseum*; *Longifolium Harrisi* (Bermuda Lily), pure white, with very large flowers.

Lilium auratum.—Of all the lily tribe this is the finest in size, sweetness, and colouring. The flowers are from 8 to 10 inches across, ivory-white, thickly studded with crimson spots, with a bright golden band through the centre of each petal.

Thunbergianum (a Japanese lily), dwarf in habit, with extremely showy handsome flowers. Valuable for pots or bedding. Japonica, the beautiful "Spider Plant," may be here included, as also Sarniensis (Guernsey Lily), which belongs to the Amaryllis tribe of bulbous plants. The Japonica sends up flower stalks 9 to 12 inches high, which are crowned with umbels of bright red flowers with long curved stamens.

Among the lilies must be mentioned the Calla, or *Richardia* (Lily of the Nile), and a dwarf variety of the same, C. Little Gem, which is very handsome and valuable for table decoration. *C. Ethiopia* (Arum Lily) has large foliage, beautiful white flowers, deliciously scented. It prefers a moist situation, and makes a fine pot plant.

A very handsome and peculiar flower is the *Calla sanctum* (Black Calla). The flowers are large, of a deep-purple colour, with black pistils standing well out of the flowers. The foliage also is very handsome and curious.

Agapanthus and Crinum: The Crinum resembles the Agapanthus, which is a strong tuberous plant, with a flower stem 3 feet in height, surrounded by a crown of beautiful blue and white flowers. The Crinum produces the same tall flower stems, but its flowers are more feathery. Both will thrive in any ordinary garden soil.

Lilies may be propagated by means of the scales of the bulbs, separated and planted in sand, but the safest way is by separating the small offsets or the bulblets that are produced in the axils of the leaves of some species.

ANEMONS.

These beautiful flowering tuberous plants (Wind Flowers) deserve a place in every garden. The foliage is very beautiful, the blooms last for a long time, and they rank amongst the garden plants which are easiest of cultivation. The Anemone requires a rich loamy soil, but care must be taken that no manure comes in contact with the tubers. If it does, they are certain to perish. The tubers should be planted in masses to produce the best effect. They must be lifted annually or bi-annually, as soon as the foliage has decayed, then dried and stored away until March, when they may be replanted. Seed sown in the spring and left in the ground will flower in the following spring. The tubers should not be planted deeper than 2 inches in heavy soil, or 3 inches in light. When planted in rows or in patches they should be set in rows from 1½ to 2 feet apart, with from 9 to 12 inches between each plant. The same distance between each plant is advisable when planting in patches.

Anemones are reproduced by dividing the tubers and from seed, as the plant seeds freely. The seeds, being very woolly, require to be mixed with sand and rubbed, to separate them, then sown in light soil in boxes.

SOME GOOD ANEMONES.

A. coronia; *A. fulgens*; *A. stillata*. *A. pulsatilla* is a handsome species, flowering towards the end of spring. There are blue, red, lilac, and white varieties. *A. japonica*, rose-coloured double; Dutch, double and single; the Budi, an extremely beautiful single variety, pure white, flowers freely; *Fulgens*, the Scarlet Wind Flower, has rich, dazzling, scarlet flowers, and is of light elegant growth. This is a double-flowering variety of *Fulgens*.

IXIAS.

This is a genus bearing very beautiful flowers. Scarcely any species of bulbous plant exhibits such a variety of brilliant colours as the *Ixias*. They are of very easy cultivation, either in pots or in the open ground. They prefer a light, sandy, and well-drained soil, and may remain in the same situation for several years. The bulbs should be planted from 4 to 5 inches deep. Plant in August and September.

IRIS.

There are several sections of this beautiful family of bulbous and herbaceous plants. All are very hardy, and, as a rule, they flower freely. They will thrive in almost any soil with very little care. Some kinds require a dry warm situation, others love the margins of streams and ponds, and others, again, revel in swamps, and even in running water. Such as these require plenty of shade. The Iris is also very effective when grown in a rockery. The Flag Iris the best known and the most extensively grown in this State. The foliage of this variety is broad, and the flowers blue-white or purple. This is the Iris Germanica and its hybrids, all bulbous plants. The Japanese Iris, on the other hand, has a fibrous root, and produces tufts of foliage, 3 to 4 feet in height, when well grown, above which the large distinct flowers are borne during the summer. There is a greater range of colour in this than in any other section. It grows to perfection when planted beside a watercourse or in any very damp situation, but will also thrive fairly in ordinary borders if the soil is of a loamy nature. The colours of the English Iris are white and purple; those of the Spanish Iris are yellow, bronze, lilac, and white. The plant is propagated by division of the roots, which, in the bulbous section, should be planted at a depth of from 4 to 6 inches, and about 4 inches apart. They may be allowed to remain three or four years in the same situations.

VARIETIES.

Kaempferi, many varieties; Lusitanica; Persica; Pavonia (the Peacock Iris); Susiana; Xiphium (Spanish Iris); Xiphoides (English Iris); and many others in great variety, including some winter-flowering species.

SPARAXIS.

This is another of the Iris family, a genus of low-growing, large-flowered, Ixia-like plants, of gorgeous colours and rich markings. They are very hardy, and do well in beds and borders. They are also closely related to *Ixia*, *Babiana*, and *Tritonia*, and require similar treatment. The commonest species are *grandiflora* and *tricolor*, of which there are numerous varieties. *S. pulcherrima* is very different in habit and appearance from the others. Strictly, it belongs to the genus *Dierama*. Its leaves bear a resemblance to those of the Iris; the stems are long and slender, attaining a height of 6 feet when well grown. They rise in a gracefully arching manner, like the stems of a tall grass. The flowers are like bells, about 2 inches long, and droop prettily from the stem at intervals

of a few inches. The colour is rosy purple. It lasts for a considerable length of time in flower during the summer months. Plant in August and September.

TRITONIA.

This genus of the Iris family contains several species, and a large number of varieties of pretty flowering plants, resembling Sparaxis in habit and appearance, and requiring similar treatment.

WATSONIA.

Another member of the Iris family. Some of the species are very handsome. In habit they resemble the Gladiolus, but most of the species have tubular flowers. The treatment applicable to Sparaxis suits them.

AMARYLLIS.

These, if planted in April and up to August, make a fine display during the spring and summer months. They are unsurpassed in value as bulbous flowering plants. They may be grown to perfection either in pots or in the open soil. The most suitable soil is a rich sandy loam, further enriched with bonedust, leaf mould, or well-decayed manure. The bulbs may be planted either singly or in clumps of from three to five, and they may remain for some years, until the patch becomes over-crowded with offsets, when they should be divided. If grown in pots, they must be repotted annually; a 7-inch pot is sufficient for the largest size. No more water must be given to them during the winter, the soil being allowed to become quite dry. During the summer feed them with liquid manure.

Amaryllis belladonna is a distinct species, which flowers in autumn. The flowers are of a delicate pink colour.

Formosissima (Spreckelia) (Jacobæan Lily) is a deep crimson.

Purpurea (*Valotta purpurea*) has bright orange-scarlet flowers.

The Hippeastrum belongs to the Amaryllis family. Its flower stems are from 18 inches to 2 feet high, surmounted by remarkably handsome large heads of trumpet-shaped flowers of various shades of crimson, striped with white, and white grounds with crimson markings. They make charming border plants, and are of very easy culture. Old and New Varieties: There are about forty species of Hippeastrum, all native to tropical America, but only seven or eight of the most showy ones are generally cultivated. Some of these, such as *H. pardinum* and *H. Leopoldi*, naturally have blooms 7 or more inches across, others expand from 4 to 6 inches, so that hybrids bearing flowers nearly or quite a foot in diameter do not appear astonishing, in view of the results obtained during the last 100 years by European fanciers. The centre of interest in these showy blooms have been Belgium and England, where show varieties of the greatest perfection have long been raised. Some of these increase but slowly, and are held at comparatively high prices, £5 to £6 being frequently demanded for a single bulb; others in time becoming sufficiently numerous to be offered at reasonable rates. The effort is to develop flowers of symmetrical form and good habit, as well as of great size and rich colouring. Raisers are particularly anxious to get rid of the green centres so characteristic of many species, and which persistently crop up in their otherwise charming offspring. Among the many varieties, the following are most showy, and are easily cared for:—Charles Dickens, very large, pure white with faint rosy stripings; Chatrain, very large round blooms, orange, with scarlet featherings, immense foliage, profuse bloomer, usually producing eight flowers at once; Jeanne D'Arc, cream white, striped and margined crimson, well-formed blooms, six to eight at once; Defiance, vigorous and free, often blooming twice in a season, large flowers, deep-red, striped white; Prince of Orange, large flowers, orange and white with greenish centre; Johnsoni, an old favourite, having been raised by an English watchmaker named Johnson a century ago, and

largely grown in Bermuda and the Caribbean Islands, as well as in the warmer parts of our own country, deep-scarlet, striped with white down the centre of each petal; and Empress of India, dazzling scarlet—a little difficult to grow. The Nehrling and Burbank hybrids, with their stately growth, good finish, pleasing colour, and grateful perfume, are fine additions to the above list, which might be greatly extended. The window culture of *Amaryllis* is not difficult when the needs of the bulbs are considered. They should be kept in comparatively small pots of light rich soil, given abundance of light, heat, and water when growing, and stored in a warm dry place when at rest.

BEGONIAS.

There are several distinct groups of Begonias, most of which will thrive in the open in Queensland. The shrubby species, which flower at all times of the year, include a large number of species and varieties, among the latter being the beautiful "Gloire des Sceaux." The ornamental-leaved group, of which *B. Rex* is the type, includes many handsome-leaved varieties, and the tuberous group, which are treated as green-house plants.

Begonias have been highly improved of late years, and as they are admirably adapted for the green-house as well as for planting out in warm districts in sheltered positions, and are easy to grow, no lover of horticulture should neglect them.

Occasionally double tuberous Begonias bear both double and single flowers. This is easily accounted for. If the grower will observe the flowers of his single-flowered plants he will find that they are of two kinds—pistillate and staminate. Now, in the double-flowered plants the staminate flowers will be double, because the stamens have turned to petals, while the pistillate will remain as they are upon the single-flowered plants. There are no tuberous Begonias that bear all double flowers. They all vary in bloom as described.

As pot plants they require considerable attention in the matter of repotting. They thrive in ordinary compost made open with plenty of sand. The seed may be sown on the surface of well-drained pots or pans of such loam, and subjected to a heat of 65 degrees Fahr., a temperature easily obtained both night and day in Queensland in spring, which is the time to sow the seed. They do not require much water. The seeds take rather long to germinate, and do so irregularly. It is, therefore, necessary to carefully lift out the largest seedlings to make room for succeeding young plants. The tubers rest during the winter months, and they must be left unwatered during that period.

Begonias are invaluable for the decoration of the green-house or conservatory, where they produce a magnificent and dazzling display. Their handsome large flowers, often measuring 4 inches in diameter, are of the most brilliantly varied and delicately beautiful shades, from the purest white to the deepest crimson, including yellow, bronze, rose, and other intermediate shades. The tuberous-rooted Begonias are also eminently adapted for bedding, and are largely used in England and elsewhere for this purpose.

GOOD VARIETIES.

Laing's Gold Medal Hybrids, single and double; Benary's International Prize, single; *Tuberosa vittata*, flowers marked like a Carnation, with shades of white, yellow, and red; *Hybrida marmorata fl. pl.*: The plants are of sturdy habit, and produce upright-standing very double flowers of great size (up to 4½ inches in diameter), with beautifully spotted and marbled petals. When in full flower these robust free-blooming plants, with their ample dark-green foliage, are most attractive.

GLOXINIAS.

These are usually considered as hot-house plants, mainly because they require a temperature of from 60 to 80 degrees Fahr. to thrive to perfection. Such a temperature obtains in Queensland, on the coast, for nine months in

the year; and where cold draughts of air can be avoided, and a moist warm atmosphere can be secured or created, these beautiful plants may be raised without the aid of the green-house, and with certainty in the bush-house. Heavy rains are, however, inimical to them. Still, they are properly adapted for indoor culture. The Gloxinia is one of the handsomest tuberous plants in cultivation. The fleshy velvety leaves are extremely beautiful, and the most lovely combinations of colour are found in their large campanulate flowers, which stand 6 inches above their silky velvety leaves.

The colours of the flowers vary from deep-crimson to pure white, with a scarlet blotch on the throat, and violet with indigo spots.

The plant is a tender perennial which blooms for a long time. Plants are easily raised from seed, which should be sown early in spring in pots, with a very light sandy soil, spreading the minute seeds thinly over the surface. The pots must be placed in a brisk bottom heat, which can be obtained by arranging for them a box containing an inch or two of damp ashes at the bottom, and having a glass cover to ensure a moist heat by checking evaporation. The seeds soon germinate, and as soon as the plants are large enough to handle they should be pricked into pans, returned to bottom heat, and afterwards potted singly. By doing this, they will flower in the first season. The most suitable soil is a compost of light loam with a little peat and silver sand added. Apply weak liquid manure once or twice a week when the plants are in full growth. This will add to the size and intensify the colours of the flowers. The plants prefer shade; therefore the sun must not be allowed to shine on them. The atmosphere must be damp, but no water must touch the leaves or flowers.

As soon as the flowers begin to open, the plants may be removed to a temperature a few degrees lower than 60 or 70 Fahr. When the foliage begins to decay, water must be gradually withheld, and the leaves will fall off naturally. The pots may then be placed in a situation out of the way, not too cold nor too dry, or the tubers may be turned out of the pots and placed in boxes in a mixture of heath soil and cocoanut fibre, and placed on a shelf, the soil being kept sufficiently moist to prevent the tubers from shrivelling. As they begin to grow in early spring, place them in small pots and water them. When necessary, shift them to larger pots. Sow from September to December.

GOOD VARIETIES.

Gloxinia (*Hybrida grandiflora crassifolia*); Gloxinia, New French Tigred and Spotted Varieties: The finest of these most beautiful varieties, of immense size and great substance, rich colours; Gloxinia, Defiance, "The Scarlet Gloxinia": Large erect flowers, glowing crimson scarlet; the edges of the petals are delicately frilled, which adds considerably to their appearance; New Giant Gloxinia (*Gloxinia hybrida gigantea*): This strain produces flowers of quite unusual dimensions. If the seed is gathered only from strikingly beautiful flowers, the latter will measure from 4½ to 5 inches across, and the show of colour thus produced is rich and varied in the extreme.

FREESIAS.

These charming tuberous plants were originally introduced from the Cape of Good Hope. They are very easily cultivated in ordinary garden soil, and, once planted, they may remain for years in the same place, blooming freely every year in the spring.

THE BEST VARIETIES TO PLANT.

Freesia refracta alba: The flowers, which are pure white, and occasionally marked with a violet line, have a delicious perfume, and are of great value for cutting. Each bulb bears one or more stems, with eight or ten flowers.

F. Leichtlini: White, passing to primrose, with orange veinings. *F. Armstrongi* (the Pink Freesia): A lovely, satiny-pink variety of these sweet-scented flowers.

RANUNCULUS.

All the Ranunculi are valuable as cut flowers. They grow freely in the open, but they require a very rich loam. Like many other bulbous and tuberous plants, contact of the tubers with manure is injurious, and usually fatal to them. In order, therefore, to enrich the soil, the best plan is to first remove 2 inches of the surface soil of the bed. Then break up the soil beneath to a depth of 15 inches, and mix with it one-third of its bulk of decayed horse and cow dung, in equal quantities. In about a month afterwards return the surface soil, and plant the tubers in it. The danger of contact between the tubers and the manure is thus avoided, whilst plenty of plant food has been provided for the roots to take up. Plant the tubers about 6 inches apart, covering them about 1½ inches above the crown. Should the soil become dry in spring before the plants have flowered, a good watering ought to be given. To obtain blooms of best quality they should be shaded from the time they begin to expand. As soon as the leaves have faded the tubers should be lifted, kept in bags in a dry place, and replanted in March or April. Amongst

THE BEST VARIETIES ARE

Double Persian Ranunculus, which can be obtained in a number of varieties. The Persian Ranunculus is prized for its lovely form and its brilliant and attractive colours—white, scarlet, crimson, yellow, purple, black, &c. The flowers are beautifully imbricated, and as full and double as the finest Camellia or Rose. Double Turban: The Peony-formed flowers are larger than those of the Persian varieties. Their vivid flowers are very attractive. They differ from the Persian, not only in size, but also in colour, being more rose-like, and self-coloured. They are very effective in beds and in masses. French Ranunculus: Turbans—black, crimson, scarlet, yellow; Seraphique, citron yellow; *Viridiflora*, green, with a scarlet edge; *Grandiflora*, large crimson, with yellow stripes.

TUBEROSE.

The Tuberosa (*Polyanthes tuberosa*) may be classed amongst the most lovely and popular of tuberous-rooted plants, admirable for the purity and fragrance of its white flowers, which are produced in summer.

It is one of the most beautiful summer-flowering bulbs in cultivation. The blooms are of the purest white, and of the most exquisite fragrance. The wax-like flowers are produced on tall racemes, and are admirably adapted for bouquets and button-holes, every pip being available. For these reasons they are cultivated in immense quantities in nearly all quarters of the world, more especially in Europe and in the United States of North America, and to a lesser extent in Australia, New Zealand, and Tasmania. They are very easy to cultivate, and thrive luxuriantly in the open in Queensland. They require a rich soil, rather sandy, and a warm situation.

GROWING BULBS IN WATER.

The cultivation of bulbs in water is a very easy and pleasant way of insuring a crop of flowers in the house. But we advise you not to attempt to grow Hyacinths in this way, as it is almost sure to result in failure. The Chinese Sacred Lily, and all other varieties of Narcissus or Jonquils, will do well either in water or soil. The following directions are taken from the "California Cultivator":—

One of the most artistic and inexpensive methods of cultivating blooming plants for home use is to grow bulbs in water. The Chinese are expert in this work, and at their New Year festival the streets of Honolulu show a profusion

of their Sacred Lily in full bloom (says the "Hawaiian Forester"). Very many varieties of flowering bulbs may be successfully grown in water, and it is surprising that this easy method of producing handsome blossoms should have been allowed to remain so long neglected.

In selecting bulbs for this purpose, large heavy ones should be chosen. In many cities glasses are made especially for the purpose of growing the handsome flowers of the Hyacinth, but any open bowl or vase can be used for these and other bulbs.

If grown in an open bowl, the bulbs selected for blooming should be supported with a sufficient quantity of clean small stones or pebbles, to allow the developed plants to retain their upright position. Water should then be poured over the stones until it reaches the base of the bulbs. The bowl should now be kept in a cool dark place until the roots have attained a good growth, care being taken to replace the water as it diminishes. When the bulbs are required to bloom, the bowl should be removed into a light warm atmosphere, when spikes of blossoms will soon be thrown up.

Besides the Chinese Sacred Lily or Narcissus, many other bulbs can be made to produce blossoms in this manner. Among these Hyacinths, Jonquils, and Crocuses have all produced satisfactory results.

THE AUSTRALIAN BUFFALO.

Mr. Alfred Searcy, in his new book, "In Australian Tropics," says of the buffalo in the Northern Territory of Australia that it is simply marvellous how the few animals which were turned loose when the old settlements were abandoned increased. In little over ten years nearly 50,000 hides were exported. The business of shooting the beasts for their hides was begun in a very small way during the eighties, but it suddenly became a regular industry, at which many men made a living. Buffalo shooting had the advantage of combining exciting sport with profitable work, as they are ridden down and shot from the saddle. Mr. Searcy mentions a particularly well-trained horse which was used for the work by a man named Cahill: "As soon as a mob of buffaloes was sighted the horse, as a matter of course, galloped alongside, while his master attended to his particular part of the game. Forty-five killed in one day proves that rider and horse understood the business thoroughly. When the shooting was finished for the day, the horse of its own accord would proceed to each carcass, and stand there till the skinning was finished." This horse at a word from his master would chase objectionable natives out of camp.

Some attempt, Mr. Searcy says, was made to tame these feral buffaloes, and use them for draught work, but no good result was achieved; they are too wild. A number were once rounded up and confined in a strongly-fenced yard, but by some oversight no provision was made for watering them. It was determined to drive them to water, and the attempt was made; but as soon as the yard was opened the herd took flight, and were seen no more. There was a story current that a man once succeeded, as he thought, in breaking a team of buffaloes to draught, and yoked them to a dray; he started, "and that was the last ever seen of man, buffaloes, or dray."

In connection with the above, it is interesting to learn that at last someone in the old country has come to believe in the existence of the buffalo in Australia. We have at this moment a most interesting story on the method of buffalo hunting in the Northern Territory. We sent this story to several London publishers, and all rejected it (though well and racily written), on the ground that "there were no buffaloes in Australia." The editors doubtless confused our buffaloes with the American bison.

Sericulture.

SILKWORMS, AND HOW TO REAR THEM.

The following paper on the production of silk has been kindly contributed by Mrs. J. South, wife of Captain J. South, late of the s.s. "Lucinda." Mrs. South has always taken great interest in the silk-producing industry, and is anxious to see it established in Queensland. Many years ago we remember boys and girls of the primary schools (as State schools were called in the early days) raising large numbers of silkworms, but nothing was done on a commercial scale. We ourselves sent two little bales of cocoons to England, where they realised 4s. per lb.

Mrs. South says:—

"The rearing of the silkworm and the production of silk has been successfully attempted in Queensland, but through lack of a suitable market the industry has practically ceased. The object of this paper is to point out that the climate and facilities of Queensland are such as to point to the probability of this becoming a lucrative employment in the near future.

"When in New York I visited a large silk manufactory in West Hoboken, New Jersey City, and was introduced to one of the leading men, who escorted me through the works. He presented me to the Japanese silk expert. This gentleman assured me that Queensland was a most suitable country for the rearing of the silkworm, on account of the warmth of the climate and the ease with which the necessary food could be obtained. This conversation led me to think of the advisability of laying my views on the matter before the public in the hope that something practical might eventuate.

"Both boys and girls find the rearing and management of the silkworm an agreeable and fascinating pastime, and I am sure country children would find a pleasure and profit in its cultivation. I would suggest that the matter be brought before the Educational Department, with a view to stimulating the interest of young people in this matter. Could a suitable market be ensured, it would open up a new industry both for young and old.

"In view of this matter coming to a practical issue, I submit a few facts on the management of the worm. The eggs should be placed in trays made of stiff white paper, and fully exposed to the heat of the sun, and should remain undisturbed until they begin to hatch. As the young worms appear they should be removed into other trays and fed on mulberry leaves, the leaf of the white mulberry being the best for this purpose. (The black mulberry, lettuce, and young grape also form good food.) They should be kept in a temperature ranging from 60 degrees to 70 degrees, in a place well-ventilated and preserved from damp or excessive dryness. Suitable rooms in which to rear the worm can easily be made on the following plan:—A kind of slanting shed made of rough wood, with slabs or tables around it, and windows to lift up on a hinge at the top, built where the sun's rays can help to bring the worm to perfection. In lifting the worms from one tray to another they should not be touched by the fingers, but removed by a camel hair pencil. The caterpillar has four moultings, each of which may be accomplished in four days, and during this time the insect requires the greatest attention. About thirty-two days after hatching the caterpillar has attained its full size. It now appears semi-transparent, ceases to eat, and prepares to spin. When this period arrives, instead of showing any migratory disposition, the worm seems to place itself with confidence under the care of man to provide it with a suitable place for its convenience and protection. What is called the cocoon nest is made by twisting the corners of a piece of writing paper and making a cornucopia, which should be affixed by a pin to the walls of the paper tray. Into each of these a single

worm should be placed. After the formation of the cocoon, care should be taken to prevent the chrysalis from eating through the walls of its silk dwelling. At least twelve cocoons at a time may be wound off by means of a winder affixed to an old machine. Where a large number of cocoons have been spun, the chrysalis may be killed by being exposed to the heat of a warm oven for ten minutes, when the silk may be wound off at leisure. The chrysalis retained for the purpose of breeding should be placed in bran, and in course of time turns into a moth. The male speedily dies; the female lays about 300 or 400 eggs and also dies.

“In conclusion, I express the hope that in a few years Queensland may become a home of silk culture.”

Some very erroneous and visionary impressions have prevailed regarding the profitableness of this industry. Some time ago, to prevent disappointment, the Department of Agriculture emphasised the fact that the profits of silk culture are always small, and that the elements of successful prosecution of the industry on a large scale in this State were then (1893) entirely wanting, and it was only recommended as a pleasant adjunct to the ordinary occupations of the farm, finding employment for those of the farmer's household not otherwise remuneratively employed. The want of a ready market for cocoons was then one of the chief drawbacks to any extended enterprise in cocoon raising. Until, therefore, the creation, by the establishment of silk-reeling factories or an export trade, of a profitable market for cocoons, intending sericulturists were earnestly advised to limit their operations. Coming to the present day, conditions have not materially changed, as, owing to labour conditions, such an industry could only be carried on by young people on the farm.

Commercially, sericulture may be divided into three branches:—

- (1) Raising seed (as the eggs are called);
- (2) Producing cocoons;
- (3) Reeling establishments.

RAISING SEED.

This used to be a very profitable industry at one time—and may be so again—when, owing to disease amongst the silkworms in Europe, a considerable demand sprang up for silkworm eggs, some millions of ounces being annually imported from Japan, China, and America. The price paid was often as much as £2 per oz., and the profits per acre in such case often reached £200. But since M. Pasteur introduced his system of egg selection, European silk-raisers have been able to produce their own seed. This branch of the industry, therefore, can only be profitable if the local demand is great, and then only to a few, as, after the first start, everyone would raise his own seed.

PRODUCING COCOONS.

This part of the business may be made to pay, but gives no fabulous profits, simply a fair income, easily earned, and at very little cost. The following figures will convey some idea of what can be done in cocoon producing:—Two ounces of eggs will contain 75,000 eggs at the very least (the number of eggs to the ounce varies with the variety, reaching as high as 50,000); 75,000 eggs with fair care will hatch out 75,000 worms; 75,000 worms, allowing 25 per cent. for deaths during rearing—a fair allowance—will produce 56,250 cocoons; 56,250 cocoons, allowing 300 to the lb., will yield 181 lb. of green cocoons; 181 lb. of green cocoons will sell for 1s. per lb., equal to £9 1s.; 181 lb. of green cocoons, when dried, will be reduced to 119 lb., and will sell for 4s. per lb., equal to £23 16s.; 56,200 worms will consume 3,200 lb. of mulberry leaves.

Now, the product in leaves of half an acre of mulberry trees, planted 4 feet apart—namely, 2,730 trees—when three and a-half years old, will be about 5,000 lb., or sufficient to feed twice this number of worms.

These figures are applicable to a district where the conditions exist for only rearing an *annual* silkworm. But in tropical districts, where climatic conditions enable a multivoltine species to be reared, four harvests of cocoons can be easily produced.

These returns are not very large, but are well worth earning, especially at work which is not at all laborious, and which will in no way interfere with other occupations.

SILK REELING.

This is the most profitable of all three branches, if carried out with skill and enterprise. But its establishment is attended with a good deal of risk, owing to labour in the State being so costly; and, furthermore, it requires skilled labour.

Cottage reeling appliances are procurable at a cost of about £10, but it is very questionable whether silk so reeled in small quantities would be marketable, because silk reeling requires skill, and with these small parcels of raw silk it would be almost impossible to get a uniform quality. The value of raw silk depends greatly on the uniformity of the threads, its cleanliness, tenacity, &c., so that, of the three branches of sericulture above mentioned, producing cocoons seems to be the only one left which gives promise of being a profitable undertaking.

VARIETIES OF SILKWORMS.

The silkworm proper, from which the ordinary commercial silk is produced—the mulberry-feeding silkworm—is the larva or grub of a small moth known as *Sericaria mori*, but there are so many intermediate forms that it has become customary to look upon all domesticated mulberry-feeding silkworms as belonging to one species—*Bombyx mori*, a univoltine—*i.e.*, a species which goes through but one generation during the year.

Then, again, there are the bivoltines, trivoltines, and quodrivoltines, producing two, three, and four generations in the year. In India, there is a race of multivoltines, which go through as many as eight generations in one year.

The general silk crop of Europe, however, is produced by a variety of silkworm which thrives in a temperate climate, requires cold for the hatching of its eggs, and produces but one crop of cocoons in the year, and this is the most profitable. The multivoltine race would do well in the steamy climate of tropical Queensland.

THE LARVA OR WORM.

The silkworm goes through four moults or sicknesses known as “ages.” There are five of these ages:—

- (1) The period from the hatching out to the end of the first moult, usually occupying five or six days.
- (2) From the end of the first moult to the end of the second, occupying four or five days.
- (3) From the end of the second moult to the end of the third, about five days.
- (4) From the end of the third to the end of the fourth, from five to six days.
- (5) From the end of the fourth moult to the transformation of the worm into a chrysalis, usually occupying about nine days.

These periods vary somewhat, due to climatic influences and race of silkworms. The life of the worm, then, from its hatching out to the time of spinning the cocoon, varies from thirty to forty days.

Before each moult the worm generally fasts for two or three days. Every day it feeds, it consumes its own weight of leaves, but during the last few days before commencing to spin it consumes more than during the whole course of its previous existence.

The spinning of the cocoon usually occupies from three to five days, and after another three days it is transformed into a chrysalis.

In from two to three weeks after reaching the chrysalis stage, the skin bursts and the moth emerges, by moistening the end of the cocoon and pushing the silken threads asunder. The male moth is known from the female by the broader antennæ or feelers they possess.



Fig. 1.

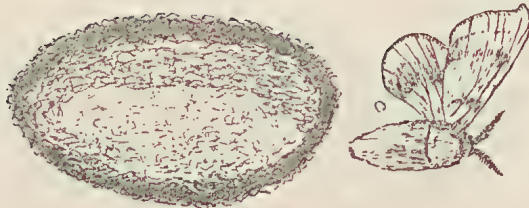
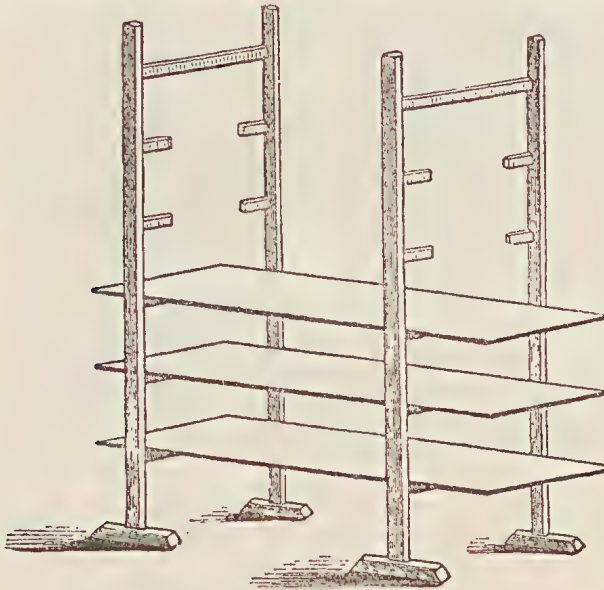

Fig. 2.

The sexes mingle soon after issuing from the cocoon, and some hours later the female begins to lay her eggs. The life of the moth extends to four or five days, but frequently to over a fortnight.

THE REARING HOUSE AND APPLIANCES.

An empty barn or outhouse can be utilised, or an inexpensive building of bark will do as well as a brick building. The size necessary for successfully



rearing the issue of 2 oz. of eggs would be a room 20 feet long, 12 feet wide, and 10 feet high. It should be capable of being well ventilated and warmed if necessary.

The interior should be fitted up with shelves or racks to hold the trays on which the silkworms are to be reared. Each rack should hold five or six tiers

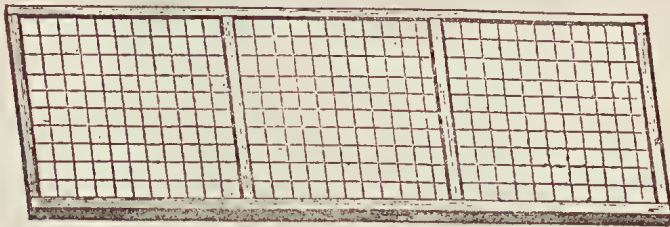

FIG. 1. — Wire-work shelf (after Roman).

of trays. The vertical distance between the shelves should not be greater than 20 inches. Wire netting for the trays is preferable, as it admits of better ventilation.

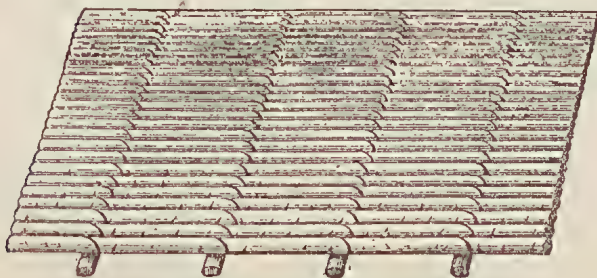

FIG. 1. — Shelf made of canes (after Roman).

In addition to the trays, a transfer tray of wire netting should be made with a large mesh, say $\frac{1}{4}$ -inch, the use of which will be explained further on. Four cocooning trays will be required 3 feet in diameter, within which is a long ribbon of plaited bamboo or matting 2 inches broad.

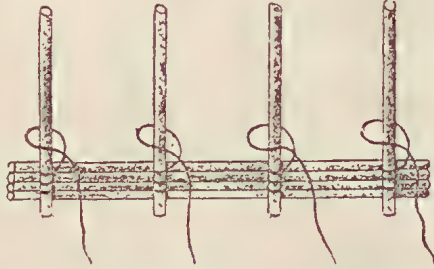

FIG. 2.—Construction of the cocoon shelf (after Roman).

Silkworms should never be handled, or at least as little as possible; and, as it becomes necessary, in order to clean up the litter made by the worms, to move them from one tray to another, the transfer tray above mentioned comes into use. One of these is placed over the tray containing the worms, and litter and fresh leaves are scattered over the top of it. The worms rise through the openings on to the leaves, when the whole are bodily moved to a fresh tray.



FIG. 2a.—Lattice-work transfer tray (original).

The first transfer, made shortly after the birth of worms, is accomplished by the aid of mosquito netting, which is laid over the hatching eggs, on which leaves cut small are placed. The tiny worms will soon rise through the meshes, and can easily be removed and tumbled out on to a tray. As they grow older, coarser and coarser mesh netting may be used.

FEEDING.

There are no definite rules as to feeding; only experience will teach what amount of food is wanted. But whenever leaves become dry they should be removed. A feed should be given in the early morning and the last thing at night always, additional meals being given during the day as the leaves are eaten. Do not keep too much food on the worms, or they will get buried and lost.

During the period of moulting no food is required, but as soon as the majority are right again feed them well. As the worms increase in size, feed them with maturer leaves, as these contain more nutritive matter; also allow them increased space.

Cleanliness is absolutely necessary for the development of healthy silk-worms.

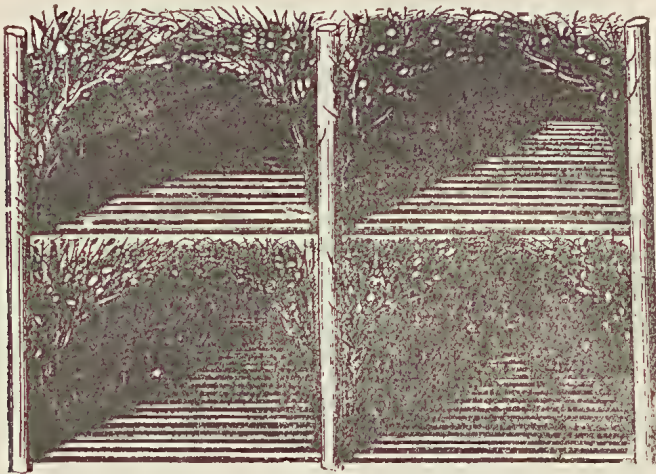

When the worms are ready to spin they lose appetite and become restless, and also throw out silk threads. Then place them in the cocooning tray, where arches of dry twigs may be built over them, the feet 10 or 12 inches apart, or they may be put into paper cocoons if raised in a small way.

When the cocoons are ready they must be sorted. The firmer they are, the better they are. The firm ones should be kept separate from the soft ones.

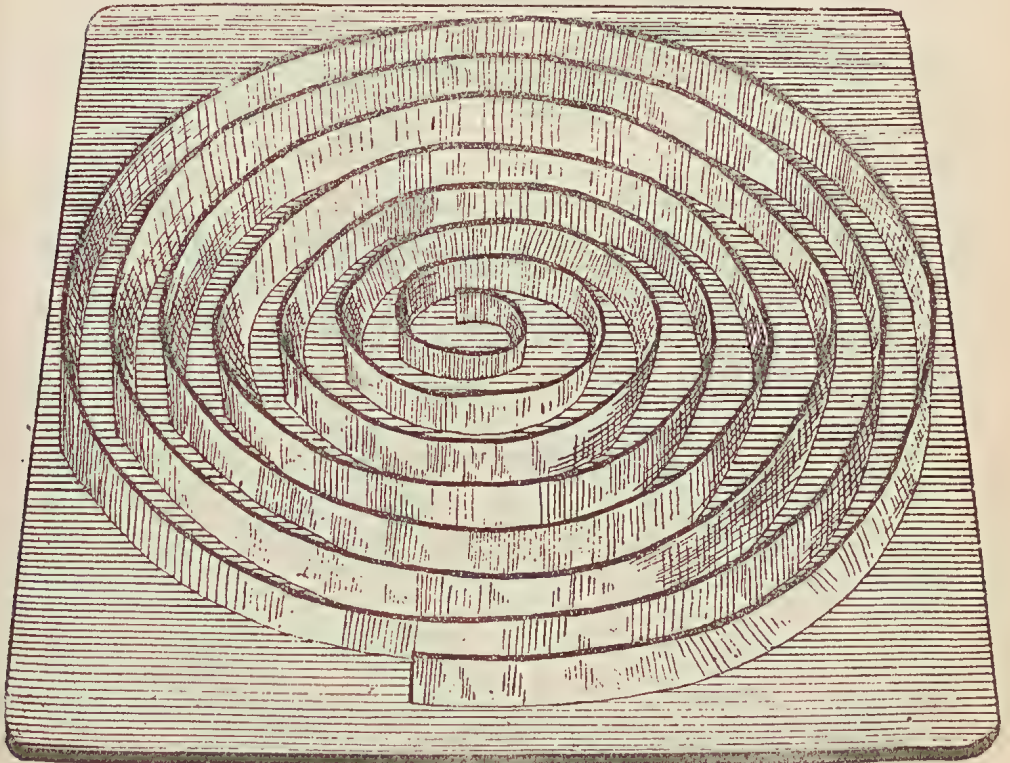

CHOKING THE CHRYSALIS.

During a Queensland summer the chrysalis is quickly killed and completely dried up by exposing the cocoons to the sun. In Europe, the cocoons are placed in a baker's oven heated to 200 degrees Fahr., or they are steamed, a very effective process. After steaming, the cocoons should be thoroughly dried. In sun-drying, after the cocoons have been two or three days in the sun they should be placed in the shade, spread out thinly, and for the first week frequently stirred. After remaining so for a month or two, the chrysalis inside becomes quite dry, and, as before observed, the cocoons can be kept for any length of time, care being taken, of course, to keep them out of the reach of rats and other vermin.

REPRODUCTION.

Before choking the chrysalis, a certain number of the best cocoons—the firmest and best coloured—are sorted out and put aside for future production. These cocoons may be either spread out on trays and left to themselves, or strung on a piece of thread (taking care not to send the needle through the chrysalis), and suspended in a room out of reach of rats, &c. In about three weeks' time the moth will make its escape, and the process previously described be repeated. The female moths should be placed on one or more trays, and allowed to lay their eggs as they please.

In our next we shall deal with the questions of food, mulberry planting, the great value of ramie (*Boehmeria nivea*) as a silkworm food, enemies and diseases of the silkworm, silk reeling and reeling appliances, and describe several varieties of silkworms.

Statistics.

COMMONWEALTH METEOROLOGY.
RAINFALL OF QUEENSLAND.

TABLE SHOWING THE TOTAL RAINFALL FOR EACH MONTH OF THE YEAR IN THE AGRICULTURAL DISTRICTS OF QUEENSLAND.

| STATIONS. | 1907. | | | | | | 1908. | | | | | | |
|-----------------------|-------|------|-------|------|------|-------|-------|-------|-------|--------|-------|-------|-------|
| | July. | Aug. | Sept. | Oct. | Nov. | Dec. | Jan. | Feb. | Mar. | April. | May. | June. | July. |
| <i>North.</i> | | | | | | | | | | | | | |
| Bowen | Nil | 1.28 | 0.51 | 0.06 | 3.71 | 6.39 | 10.14 | 5.63 | 9.46 | 3.73 | 0.99 | 4.5 | 0.88 |
| Cairns | 0.12 | 0.39 | 1.35 | 0.63 | 5.35 | 28.33 | 27.02 | 8.03 | 20.60 | 5.99 | 3.05 | 5.9 | 3.70 |
| Geraldton | 2.39 | 4.66 | 1.36 | 1.42 | 6.45 | 33.82 | 44.39 | 13.27 | 39.00 | 14.23 | 18.52 | 2.64 | 8.11 |
| Herberton | Nil | 0.11 | 0.12 | 0.17 | 3.41 | 9.57 | 9.29 | 5.02 | 8.92 | 1.40 | 0.38 | 3.1 | 2.36 |
| Hughenden | 1.16 | Nil | Nil | 1.66 | 0.66 | 7.75 | 0.93 | 5.18 | 6.91 | 0.30 | ... | 0.5 | 0.68 |
| Kamerunga State Nurs. | 0.13 | 1.15 | 1.19 | 0.53 | 2.76 | 29.82 | ... | 7.47 | 25.75 | 4.60 | 3.363 | 0.76 | 4.85 |
| Mackay | 0.27 | 0.25 | 0.12 | 0.12 | 5.76 | 9.70 | 9.23 | 3.83 | 17.43 | 14.82 | 3.25 | 1.29 | 1.65 |
| Rockhampton | 0.84 | 0.47 | Nil | 0.47 | 3.72 | 4.42 | 3.84 | 9.64 | 9.77 | 2.62 | 0.65 | 0.10 | 1.08 |
| Townsville | Nil | 0.07 | 0.14 | 0.03 | 2.82 | 24.26 | 12.21 | 6.69 | 9.03 | 0.38 | 2.22 | ... | 1.70 |
| <i>South.</i> | | | | | | | | | | | | | |
| Biggenden State Farm | 1.51 | 0.96 | 0.24 | 1.99 | 2.50 | 5.55 | 2.37 | 9.82 | 9.84 | 2.97 | 0.74 | 0.43 | 0.49 |
| Brisbane | 0.39 | 0.79 | 0.10 | 1.37 | 4.25 | 3.21 | 2.80 | 8.43 | 18.19 | 2.45 | 2.40 | 0.17 | 0.77 |
| Bundaberg | 0.87 | 0.43 | Nil | 1.70 | 2.90 | 2.99 | 4.77 | 2.82 | 7.35 | 4.13 | 0.67 | 0.39 | 0.75 |
| Dalby | 0.87 | 0.71 | 0.15 | 0.69 | 5.18 | 1.44 | 0.17 | 4.88 | 7.61 | 0.11 | 0.37 | 0.63 | 0.14 |
| Esk | 0.54 | 0.81 | 0.57 | 0.50 | 3.76 | 3.72 | 2.61 | 10.06 | 17.04 | 2.83 | 1.07 | ... | 0.46 |
| Gatton Agric. College | 0.51 | 0.56 | 0.15 | 0.71 | 3.01 | 4.55 | ... | 3.38 | 10.74 | ... | 0.10 | 0.16 | 0.6 |
| Gindie State Farm ... | 1.58 | 0.10 | 0.16 | 0.61 | 1.57 | 4.42 | 0.20 | 7.17 | 6.25 | 0.02 | 0.112 | ... | 0.40 |
| Gympie | 0.80 | 0.17 | 0.47 | 1.20 | 3.05 | 5.49 | 6.26 | 11.77 | 80.8 | 1.87 | 2.00 | 0.38 | 1.16 |
| Ipswich | 0.30 | 0.43 | 0.05 | 0.78 | 4.45 | 3.40 | 1.32 | 6.63 | 13.77 | 2.71 | 1.14 | 0.12 | 0.47 |
| Maryborough | 0.61 | 0.93 | 0.25 | 2.74 | 3.49 | 5.81 | 5.62 | 8.07 | 11.40 | 2.52 | 1.05 | 0.46 | 0.81 |
| Roma | 1.03 | 0.42 | 0.04 | 1.04 | 3.70 | 2.51 | 0.04 | 6.38 | 2.51 | 0.22 | ... | 0.50 | 0.63 |
| Roma State Farm ... | ... | ... | ... | ... | ... | ... | ... | ... | ... | ... | ... | ... | 1.27 |
| Tewantin | 1.48 | 0.95 | 0.55 | 1.05 | 3.12 | 7.36 | 10.42 | 12.47 | 14.39 | 7.59 | 8.66 | 0.75 | 1.97 |
| Warwick | 1.16 | 1.37 | 0.01 | 1.37 | 3.25 | 3.13 | 0.76 | 4.52 | 6.65 | 1.40 | 0.15 | 0.80 | 1.24 |
| Westbrook State Farm | 1.04 | 1.78 | Nil | 1.08 | 4.76 | 3.23 | 0.43 | 8.03 | 1.41 | 1.40 | 0.05 | ... | 0.49 |
| Yandina | 1.15 | 0.68 | 0.80 | 1.44 | 2.87 | 3.05 | ... | ... | 16.62 | 5.45 | 4.59 | ... | 2.64 |

NOTE.—The rainfall data in this table are compiled from telegraphic reports, and must be considered approximate only.

GEORGE G. BOND,
Divisional Officer.

Vegetable Pathology.

ON TWO PRICKLY PEAR AFFECTIONS.*

By H. TRYON, Entomologist and Vegetable Pathologist.

I.—DRY ROT.

OCCURRENCE.

This "disease" was encountered in prickly pear on the selections of W. Gibson, W. Burton, and in one other locality in the Goondiwindi district.

With the exception of the first of these occurrences, the ground in which the affected plants were met with was flat, and, in wet weather, liable to become water-logged; but, generally speaking, the land the scene of them apparently differed in no respect from that in which normally healthy plants grew. In every instance only individual plants here and there were subject to its presence, and with respect to these it was prevalent in varying extent.

During the four days (4th to 8th October) covered by the necessary field investigations, no perceptible increase in the manifestation of symptoms took place, and the same remark applies to portions of injured plants maintained in a living condition for nearly six months.

SYMPTOMS.

The appearances presented suggest the action of some corrosive fluid, although this explanation of their origin is perfectly untenable.

The earliest indication is afforded by the presence of spots or blotches of a greyish- or pale yellowish-brown colour. These have an irregular outline and wave-like extensions in different directions, as might some drop of fluid that had become flattened out and extended. They develop one or two brownish-cream-coloured markings about their centres, that unite and grow until the entire blotch is thus occupied. These ultimately cream-coloured spots or blotches are of every size, and, by confluence, may form archipelago-like patches. Both faces of a stem-section (or "racket") may exhibit their presence. Oftentimes it is affected along one edge, the alteration extending inwards to a varying degree, and in one or more places; sometimes entire "rackets" become implicated. All the stem parts of the plants, both young and old, may be affected in this way. Throughout the areas of different form and extent involved in these changes, the epidermis has already died, as is suggested by the colour it has acquired, and cracks and fissures develop either just within their borders, so as to isolate them from the surrounding green tissue, or are met with traversing them in different directions.

These fissures have the effect of exposing the subjacent green tissue of the "rackets" to the direct action of the surrounding air, with the result that this, which is very intolerant of its action, succumbs and to a greater or less extent, breaks down.

The affected portions of the stem-sections, which, as we have seen, may comprise their entire surfaces or any lesser portion of them, accordingly develop

* This preliminary statement—submitted in the form of a Report—is the outcome of an inquiry promoted by the Secretary for Public Lands—the Honourable J. T. Bell, M.L.A.—to whom the question of subjugating the notorious weed—the prickly pear (*Opuntia vulgaris*)—by disease had early been commended by the writer as one worthy of especial consideration.—H.T.

a shrunken appearance—the entire interior having collapsed—the external surface, in addition to exhibiting breaks in its continuity, being much wrinkled and puckered.

Meanwhile, these portions or the entire “rackets” dry up and become as brittle as biscuits, still, however, maintaining the pale colouration, and in this respect resembling them.

Only rarely, and when they consist of a few “rackets” only, are individual plants wholly affected in this way. Usually but a leaf here and there exhibits, with varying intensity, the symptoms described. Accordingly, it was nowhere observed to be a fatal affection, but, where best developed, to produce a retarding influence on growth only. By a small expenditure of time and labour, as effective results might arise from the application of arsenite of soda or of some such cacticide.

NATURE.

There is a sudden demarcation between the healthy green parts of the stem-sections and those parts subject to the alterations described. This remark applies not only to the external surface but to the underlying tissue comprising the substance proper of the plant. In the latter case, however, there is generally a brownish-coloured line separating the sound from the unsound.

At first, and when the marks are recently formed, the change undergone, and of which they are the indication, is quite superficial, and is restricted to the epidermis; and, if secondary changes do not ensue, no further alterations may take place, so that by scraping away the dead skin the subjacent deep-green substance of the leaf is brought into view.

When, however, with its death, this dry and discoloured epidermis cracks, and fissures develop, changes take place similar to those that result from a wound, and proceed to deeper and deeper depths in the tissue until the entire thickness of the stem-sections or “rackets” is involved.

Sooner or later the destructive alterations cease, and whatever portion of the stem-section has remained uninvolved in them manifests all the symptoms of life, and, even under the most uncongenial conditions for growth, may develop vigorous sprouts.

Apparently certain meteorological conditions determine the extent to which the destructive changes may proceed.

These changes are thus both partial and transitory in their effects, and so have but little, if any, influence in subduing the plants that exhibit them.

CAUSE.

The symptoms exhibited at an early period in the history of this prickly pear affection are, generally speaking, compatible with the action of some parasitic organism—of a fungus or bacterial nature. However, microscopical investigation fails to bring to light the presence of any such agent. Moreover, when kept under conditions favourable to their growth and manifestation, no micro-fungi capable of acting as parasites are found occurring, much less any one of the several kinds that are known to consort with *Opuntia* as a host-plant.

The features that are the earliest to be displayed suggest the action of some toxic fluid, formed within the plant tissue, and acting sporadically on the more superficial cells of the cortical layer of the plant, and on their contents.

No micro-chemical action of this character has, however, been determined, and it can, therefore, be conjectured only—if it indeed, actually takes place—in what it consists.

In this connection it may be remarked that in the prickly pear a singular feature is exhibited, consisting in the presence of a layer of cells, intervening

between the chlorophyll-containing palisade cells and the epidermis, each of which contains a large sphaerolith of oxalate of lime, and this is denotive of the fact that during the growth of the plant a large amount of oxalic acid is formed, probably in connection with the special metabolism involved.

Could we conceive that under exceptional circumstances the reduction of this oxalic acid takes place to form poisonous bodies—*e.g.*, glycollic or glyoxylic acids—that are created in the course of this process, prior to its being rendered inert through union with lime, such action would account for the figure that characterises the initial changes when first apparent—that of a drop of fluid flattened out. However—as I am assured—such action as is referred to is unknown to the physiology of plant-life.

CONCLUSION.

From what has been stated regarding the appearance of this prickly pear affection and its nature, it will appear that it is not one of any economic importance, although not devoid of scientific interest.

At the time of my visit it had been under the observation of Mr. W. Burton for some weeks, and more recently had claimed the attention of his neighbour, Mr. W. Gibson, and no facts were communicated by either contrary to this opinion.

Efforts on my part to communicate it from one plant to another, or, indeed, from one stem-section to another of the same plant, yielded entirely negative results, and this, whilst again supporting the conclusion that we have not in it an instance of a parasitic disease, coupled with the fact that no instances of its spontaneous dissemination were encountered, is in keeping with the view that this judgment concerning it is a sound one.

At the same time, all abnormal features, especially of the nature of spontaneous destructive change in the prickly pear plant, merit, in the public interest, the fullest investigation, and it redounds, therefore, to the credit of the Commissioner of Crown Lands at Goondiwindi, F. W. Barlow, Esq., in that he not only brought this under the notice of the Secretary of Public Lands, but assisted in every way also in promoting the inquiry to which this report relates. The services of Messrs. W. Burton and W. Gibson, of the same district, are also worthy of record.

II.—SLEEPING SICKNESS.

OCCURRENCE.

This prickly pear affection was met with near Milmerran, in the parish of Domville, where it had been discovered by Crown Lands Ranger A. A. E. Brett. It is not of uncommon occurrence in the western districts of the State, the following being districts in which it has been seen:—

Jondaryan (G. F. W. Suzbier), Mamadhu (J. Coghlan), and Goondiwindi, as well as here and there in the intervening country. Isolated plants are victimised by it, and, where prevalent, the percentage of affected to non-affected ones is very small. It is the exception for two or more adjacently-growing plants to manifest it. The land on which it occurs may be well drained, but exhibits, apparently, no special character.

SYMPTOMS.

These symptoms denotive of the presence of Sleeping Sickness disease are at first very obscure, and are very gradually developed.

An affected plant, when the disease is but little pronounced, will be noticed to have its main stems spreading outwardly more horizontally than usual, and falling, as it were, from the centre whence they originate. The stem-sections, or "rackets," instead of being glaucous-green as in the healthy plant,

present now a yellowish sickly cast of colour, with the "eyes," or arrested buds, it may be, set in purplish-red. Moreover, instead of their thick edges being turned upwards, they are more or less inclined. As yet, however, they are intact, without blemish. Again, the development of the plant seems to have ceased, there being no indications of recent growth; and any fruit that may be present is little in quantity, and presents a depauperated appearance. A prickly pear plant under the full influence of this "sleeping sickness" presents the following appearance:—It manifests a yellowish cast of colour, especially when viewed at a distance, for all portions are not quite alike in this respect. It has, moreover, a battered-down look, as if the branches of a tree has been imposed upon it. The main branches droop, and the stem-sections expose their faces upwards and downwards or lie almost horizontally. These "rackets" are again thin, allowing the fibrous meshwork of their substratum to be readily seen through their outer covering, and, moreover, tough, flaccid, and wrinkled. Some have conspicuous dead areas, extending to a greater or less distance inwards from their sides or ends. Other stem-sections, again, are dead, and have dried up. These readily fall off when touched, and many, having already dropped, occur in various stages of rottenness, bestrewing the ground. No recently-formed shoots or flower buds are connected with the affected "rackets." If fruit be present, it is in almost all cases pinched and wrinkled, and readily falls when anything is brought in contact with it.

In some cases one portion of a large plant is implicated in a more pronounced degree than is another. Plants affected in this manner seldom wholly succumb, although entire branches may die and come away. Evidently many weeks are occupied in reaching the fullest stage in the development of the malady, but the diseased condition seems to be more quickly realised in dry than in wet weather.

Affected plants have a very characteristic appearance, and, when this has been once realised, may be discerned from a considerable distance.

The symptoms presented are quite distinct from those evinced by *Opuntia* during dry weather, when growing in open wind-swept places on shallow soil, although in this case also we have the "rackets" thin and yellow-coloured, and often suffused with reddish-purple.

CAUSE.

On examining affected plants, neither destructive insect nor parasitic fungus is met with, although in the case of the dead and decayed stem-sections saprophytic organisms may ultimately darken the pale-brown colour that they exhibit.

The origin of the disease is to be found, however, not in the parts of the prickly pear above ground, but in the state of its roots.

These, even when the first recognisable symptoms are outwardly manifest, have undergone destructive change that, commencing from their free ends, has gradually extended along them to their point of origin in the central axis to a varying extent.

This change, that involves their death, is especially undergone by the white dense tissue (parenchyma) that surrounds the central woody cylinder or stele. This has, where already affected, completely broken down, becoming of the consistence and appearance of thick honey, and, like, some varieties of this, of a yellowish-brown colour. When this alteration has taken place, the epidermis or "skin" of the root is removable, like an egg shell, and, indeed, in eradicating a plant this may be left in the ground, forming an open cylinder, although oftentimes only the woody central cylinder remains to be taken up. As this root decay proceeds, there is an abrupt transition between that part of the root that is subject to change, and is still sound, and the soft and decayed portion beyond.

Evidently the root decay is inaugurated long prior to the time when the disease can be first recognised, as may be judged from the extent to which it has proceeded when this is the case. Even when the entire roots are destroyed, and the decay has extended in part to the central bulbous axis of the plant, the outward symptoms may not be developed to their fullest extent, especially should moist weather prevail. The casual agent of the disease is, of course, that which determines the commencement of this root-destruction, since, when a lesion has been once produced, wound-parasites may determine all after-effects. Owing to the circumstances above mentioned, great difficulty is involved in discovering this. Thus, in the present investigation, every plant examined evinced root decay that had already been long in progress.

The agent is evidently none of the higher fungi belonging to the group *Basidiomycetes*, or such as invest the roots of plants they victimise with conspicuous spawn-threads (mycelia).

At the junction of the sound and altered root tissue, where the former has commenced to soften, and where root decay is progressing, a delicate hyphomycetous fungus may be found vegetating that is quite distinct from others of the same class that are encountered further back, where it has produced its fullest effects in destroying the tissue.

The systematic position of this as yet awaits determination, and that it is the cause of prickly pear "Sleeping Sickness" is uncertain, seeing that it has not yet been found possible to infect healthy root tissue with the characteristic decay, in which material in which it is present has been used as the infective material.

However, this is a line of investigation that needs prosecution, having been only conducted to a very limited stage in this inquiry: the claims of other official duty having to be meanwhile satisfied.

DISSEMINATION.

The dissemination of the disease under natural circumstances is evidently slow, and proceeds to a very limited extent.

Plants affected to a pronounced degree may grow alongside other ones in the same patch without any evidence that they have served to communicate the disease to them being forthcoming. Again, seedling Prickly Pear plants may spring up from the ground occupied by the decayed roots of a victimised plant, and yet escape infection; and, moreover, healthy and diseased roots may intersect the same portion of soil, and yet maintain their respective conditions of soundness and unsoundness.

Usually the disease proceeds to a certain extent, and then its progress is stayed: the affected plant apparently producing new roots, or the portions above ground that have escaped destruction establishing new soil-connections.

With such methods as I have employed, and that have consisted in inoculating the plant and soil with root tissue, decayed or in process of decay, no positive result has been arrived at in establishing the disease. It is one that will bear further and more exhaustive examination; but, it being a root disease, it is not probable that means of artificially communicating it, if arrived at, will be of much avail.

In conclusion, it may be permitted to add that the zeal for the wider interest of his Department, that had evidently prompted Crown Lands Ranger A. A. E. Brett to call attention to the Domville occurrence of this prickly pear affection, was evinced also in his highly-appreciated efforts to promote this inquiry that he was thus instrumental in occasioning.

Science.

ARTESIAN WATER.

Queensland has an artesian area of 376,000 square miles, or, practically, it may be said that over one-half of the State has, flowing at various depths beneath the surface of the Western country, vast rivers of water, which, if everywhere tapped, would suffice to irrigate not only the artesian area, but, by means of creeks and watercourses, often dry for months and even years at a stretch, as in the five years preceding 1902, would also give vast supplies of water to considerable stretches of country outside the artesian area. Whilst, however, a majority of the 600 or 700 bores which have been put down yield constant supplies of excellent water, both for domestic and irrigation purposes, as well as for supplying steam boilers, there are some with a heavy flow of water impregnated with certain salts which make it unfit for any of these purposes. The problem has been how to get rid of these injurious salts, and so render the water sweet and useful. Mr. Percy Allan, principal assistant engineer for conservation of water in New South Wales, last year read the following paper, which indicates some of the possibilities for artesian irrigation presented by the recent discovery by Mr. R. S. Symmonds, of the New South Wales Department of Agriculture, whereby the alkaline artesian waters of Queensland, New South Wales, and South Australia may be made useful instead of poisonous to plant life:—

The great artesian basin as at present known spreads over the north and north-west of New South Wales, three-fifths of Queensland, and a considerable portion of the north and east of South Australia. The total estimated area of the whole artesian basin is 569,000 square miles or 364,160,000 acres, of which 376,000 square miles are, as above stated, situated in Queensland, 110,000 square miles in South Australia, and 83,000 square miles in New South Wales. The great mass of this enormous area is at present uncultivable for want of moisture, and when to this may be applied water, which not only affords the essential to plant life, but water which also contains the highly fertilising element of nitrogen, now missing from the artesian supplies, there are the elements of a prodigious development in both pastoral and agricultural pursuits.

Mr. Symmonds' scheme is very simple, and may be briefly stated as follows:—The objectionable compound in the artesian water usually obtained is carbonate of soda, which, while unpleasant to the taste, has also a deleterious effect on plant life, and, when brought into contact with soil, forms a chemical substance known as silicate of soda. This forms a hard silicious surface, which can hardly be broken by mechanical means, and which, even when it is desiccated, is of little use after it has become thoroughly impregnated for purposes of culture. Mr. Symmonds' idea is that the addition of nitric acid to the water would neutralise the objectionable effects of the carbonate of soda by converting it into the chemical product known as nitrate of soda, which is used the world over as a fertiliser. The effects have exceeded the discoverer's most sanguine expectations. He has proved by his experiments that the addition of nitric acid to soil impregnated with alkali procured from the neighbourhood of the bore at Moree has increased its fertility to a marvellous degree, and has converted what might be termed barren rock into soil which will grow wheat, for example, to an extent quite impossible even on the best agricultural lauds of the State.

With this object in view he obtained some alkaline soil that had been under irrigation by artesian bore water, and on 28th September, 1906, filled three

6-inch flower pots with the soil, No. 1 being the ordinary soil, Nos. 2 and 3 treated with nitric acid. Two grains of wheat were sown in each pot and



allowed to mature. The wheat was cut on 28th January, 1907, and the grain was weighed, giving the following results:—No. 1, untreated, 2·65 grammes of wheat; No. 2, treated, 11·30 grammes of wheat; No. 3, treated, 14·40 grammes of wheat. The latter showed more than five times the yield of the first-named, which was considered a very satisfactory result.

In order to make quite sure, he repeated the experiment, in duplicate, on 2nd February, 1907, and the photographs herewith illustrate the latter series of experiments. Although the season (winter) was against the growth and ripening of the grain, the results showed an increase of from eight to ten fold. The pot on the left of each photograph Nos. 1 and 5 contains the alkaline soil untreated; the other pots contain the same soil in which the injurious effects of the alkali have been corrected by the addition of nitric acid. Nos. 2 and 6 received '2 per cent., Nos. 3 and 7 received '5 per cent., and Nos. 4 and 8 received 1 per cent. nitric acid.

Two grains only were grown in each pot, consequently it is fair to assume that the "stooling" properties of wheat are greatly assisted by the process, and, as the pots containing '2 per cent nitric acid showed an increase in yield practically equal to those containing 1 per cent., it is only reasonable to suppose that the same result would be obtained by the use of a much lower percentage of acid.

Experiments on a larger scale, with from '002 per cent. to '25 per cent. nitric acid, on strongly alkaline soil from Moree are in hand. So far as they have progressed, the subsequent results are startling and convincing, and will form the subject of a subsequent article.

The mechanical power derivable from the pressure given in the outflow from artesian bores (some of the bores give a pressure so high as 150 lb. per

square inch) could probably be turned to account in producing on the spot electro-chemical nitric acid from the atmosphere, a process which is now being



successfully carried out in Europe at a cost of £8 3s. 6d. per ton. As the cost of raw material and power is zero—an occurrence unique in the industrial world—it is simply a question of plant, working expenses, and intelligent supervision.

A process to convert the atmospheric nitrogen into nitric acid has been recently investigated in Europe, and offer some novel features, which render it particularly applicable to our unique conditions, the high pressure artesian bores providing the power to produce from the atmosphere an antidote for their own toxicity, and thereby enormously increasing the fertility of the soil and rendering us independent of a precarious rainfall.

The workers of the process referred to state that they obtained a maximum output of 440 kilos nitric acid per kilowatt year when using a current of 0.05 ampere of 6,000 to 10,000 periods per second, at 50,000 volts, each are absorbing 2.5 kilowatts. So that 2.5 kilowatts (about 3.4 h.p.) produced 1.1 ton of nitric acid per year.

A plant such as that mentioned could be duplicated according to the power available. There would not be any expensive transport or packing of the acid, and it would be quite unnecessary to concentrate it for our purpose. This would mean a considerable reduction in the cost of the plant and working expenses, and the advantage of this process is apparent when working on such a large area.

The whole scheme is fascinating and sound; the geologist, chemist, physicist, electrician, engineer, and agriculturist each play an important, well-established part, and the capitalist should not be slow to recognise the advantages of an enormously increased yield. To get, in one season, with one tillage, sowing, and harvesting operation, what under ordinary circumstances would take five or six years, and to get it practically for nothing, without risk, is an

occurrence extremely rare. The results so far achieved are phenomenal, and the process may fairly be regarded as worthy of being fully investigated in the field.



From these experiments, which must be regarded as purely of a preliminary nature, it is quite impossible to attempt to estimate the cost, and until the experiment has been tried in the field, on a comparatively large area, he would prefer not to express an opinion on this point.

It will be noticed that Queensland has an artesian area of 376,000 square miles, an area far in excess of the other States, and is thus far more deeply interested in Mr. Symmonds' discovery. Mr. Symmonds has, it is said, placed formally in the hands of the Queensland Government full details of his discovery and the results of his work. He asks now that some opportunity will be afforded him to give his discovery practical test. The importance of the matter cannot be gainsaid, so we trust it will not be long before Mr. Symmonds is allowed to put his discovery to a practical test in the Western districts of this State.

General Notes.

AGRICULTURAL COLLEGE EX-STUDENTS' CLUB.

ANNUAL GENERAL MEETING.

The annual general meeting of the ex-Students' Club of the Queensland Agricultural College was held in the board-room, at the offices of the Department of Agriculture and Stock, on Thursday, 13th August.

A satisfactory balance-sheet was presented, and final arrangements were made for the annual dinner to be held on the same evening at the Café Eschenhagen. A motion was also carried to admit present students at the College as club members at a fee of 5s. per annum.

THE ANNUAL DINNER.

The attendance at the dinner this year was larger than on any previous occasion, there being some sixty ex-students and guests present. Amongst the guests were Mr. X. A. Seppelt, a member of the Roseworthy Agricultural College, Adelaide, and Mr. Dravemann, of Doobie College, Victoria. The chair was occupied by the president, Mr. J. Mahon, Principal of the College, supported by the Acting Chief Secretary (the Hon. A. H. Barlow), the Minister for Agriculture (the Hon. T. O'Sullivan), and Mr. P. J. McDermott, I.S.O. (Under Secretary, Chief Secretary's Department), and Mr. E. G. E. Scriven (Under Secretary), and Mr. J. P. Orr (chief clerk, Department of Agriculture and Stock), Mr. P. McLean (late Under Secretary, Department of Agriculture and Stock). Amongst the other guests were Messrs. H. C. Quodling, R. Jarrott, H. Hindes, J. Liverseed, G. Brookes, E. Curney, J. T. Bailey, Sydney Dodd, A. H. Cory, G. Tucker, S. S. Hooper, M. Fern, J. Carew, R. A. Seppelt, R. E. Soutter, Thomas Jones, and thirty-two ex-students. Apologies were received from His Excellency the Governor, Sir Arthur Morgan (Lieutenant-Governor), the Hons. G. Kerr, J. W. Blair, P. Airey, A. G. C. Hawthorn, J. T. Bell, and Messrs. P. M. Pitt (secretary, Agricultural College), D. Macpherson (Biggenden State Farm), G. F. Campbell (Clifton), and H. E. Laffer (Roseworthy College). The latter was, however, represented by Mr. X. A. Seppelt.

After-dinner speeches were made by the president, by the Ministers present, and by some guests, and the members of the club.

Mr. Mahon, in opening the latter proceedings, expressed himself as very much pleased with the large attendance of ex-students, all of whom he was glad to know had been successful in life since leaving the College. Fully 75 per cent. of the students who had been under him were on the land, and one, he knew, was receiving £500 a year in Victoria, in connection with dairying. Mr. Mahon paid a graceful tribute to the veteran organiser of the Agricultural Department, Mr. Peter McLean, and also spoke in laudatory terms of the work of Messrs. Winks and McGrath.

Messrs. Jarrott and Hindes followed with short suitable speeches.

Hon. A. H. Barlow made a happy speech.

Hon. T. O'Sullivan gave some account of his experiences in his late Northern tour, and enlarged greatly on the enormous extent of the State and its resources, especially in sheep in the West and sugar in the North, and emphasised the terrible want of population in the State. In mentioning State farms and College, he showed clearly the great benefit they are to the State, even as much by their failures, from which all farmers are benefited, as by their successes. They also had the good effect of inducing lads to go on the farm, and he said to them, "Go on the land, by all means."

Mr. P. J. McDermott not only made a speech, but also gave a humorous recitation. The burden of his speech was the absolute necessity for toil, incessant toil, to achieve success.

Mr. Scriven and Mr. McLean made short pleasant speeches, which were responded to by Messrs. Seppelt, Corser, Webb, Dravemann, Hindes, and others.

After conclusion of the evening, the health of the secretary to the club (Major A. J. Boyd) was drunk with musical honours. Major Boyd suitably responded.

We advise all ex-students of the College to join the club, which makes for the benefit not only of members but of the agricultural community generally. Scattered far and wide over the State as they are, these young pioneers of agriculture have a most varied experience of the conditions under which farming, fruit-growing, dairying, stock-raising are carried on in widely separated districts from South to North and East to West. The proposal, which was unanimously carried at the meeting, that present students of the College be eligible for membership is an excellent move in the right direction, and we trust that many will avail themselves of the privilege. Several hundreds of students have passed through the College, and of these the Principal said that 75 per cent. are on the land and doing well. This shows the great value of the College education. Previous to its being established, the failures in farming were numerous, for the simple reason that those who took up the work had no idea of how to work the land to the greatest profit. Neither did they understand anything about modern machinery either for working the land, harvesting crops, or for dairy work. To-day students leave the College equipped with both practical and theoretical instruction, with the result that, as before said, those who took up rural industries are all making or have made comfortable homes and fair incomes for themselves.

On Monday, 17th August, a deputation of members of the ex-Students' Club paid a surprise visit to the secretary, Major Boyd, and presented him, on behalf of the members, with a case of valuable pipes, inscribed with the legend, "Presented to Major Boyd by members of the Q.A.C. Old Boys' Club, 13-8-08." The recipient expressed his appreciation of this most appropriate gift, and promised to do all he could in the future, as he had tried to do in the past, for the welfare of the club. The presentation was made by Messrs. Binnie and Rochat on behalf of the members.

Answers to Correspondents.

OSTRICH FARMING.

ENQUIRER, Tambo.—

1. We only know of one person in Queensland who has commenced breeding ostriches—Mr. T. Behan, of Garfield, near Jericho, on the Central Railway line. Some time ago he purchased a pair of ostriches in South Australia, with the idea of trying how the birds would thrive in Western Queensland desert country. The experiment, we are informed, has been a decided success. For a first plucking of plumes of four months' growth, weighing 2 lb., Mr. Behan obtained £30. The female ostrich, some time ago, had laid twice, hatching out thirteen chickens at the first sitting and seven at the second.

That ostrich farming is a very profitable business is shown by the fact that a Bill has been passed in Cape Colony making it a criminal offence to export ostriches. Even if the Bill were not passed, there would still have remained an export duty of £100 per head.

During the year 1904 the production of feathers in South Africa amounted to 470,036 lb., of a declared value of £1,058,355. A further increase took place in 1905, for the value shipped to the markets of the world stood at £1,120,298. For 1906, the value shipped stands as a record, amounting to 547,700 lb., worth £1,406,000. The last census gave the number of domesticated birds as 358,370, as against 154,880 in 1861.

In America, where ostrich-raising has been followed for only a few years, they are held in much esteem. It is said that the Nice farmer only calculates on bringing out and rearing 60 birds from every 600 eggs, but even then he counts on doubling his flock every year.

2. Your inquiries about Angora goats are answered in an article on the subject in this issue of the Journal, and you will also find voluminous information about Angora breeding and mohair in Vols. V. to XIX. of the Journal.

FOOD VALUE OF CANE TOPS.

H. T., South Kolan.—

Green sugar-cane tops are a very valuable fodder, and have as much food value as green maize, sorghum, and similar crops.

COW WITH CONGESTED UDDER.

JOHN HUNGERFORD, Canaga, Chinchilla.—

Mr. Sydney Dodd, Chief Veterinary Surgeon, Department of Agriculture and Stock, gives the following reply to your question:—

The term "congested" udder is often used by stock-owners for "inflammation" of the udder.

Simple congestion of the udder seldom lasts longer than about ten or twelve days, but if often ends in acute inflammation after two or three days. The former should be treated by frequent milking, and the application of hot fomentations, followed by belladonna ointment to the udder.

Inflammation of the udder is a more serious complaint, but may be prevented to a great extent by paying strict attention to cleanliness, avoiding over-stocking, and by treating injuries, &c., to the teat or udder promptly. Contagious inflammation of the udder is a disease caused by specific organisms

which may be introduced into a herd by an infected cow, and is then spread from cow to cow owing to the milker's lack of attention to personal cleanliness or by the milking utensils.

Generally speaking, in cases of inflammation of the udder, belladonna ointment should be applied to relieve pain, and the udder stripped every hour.

The bowels should be kept open by moderate doses of Epsom salts.

The teats may be injected with a warm solution of boracic acid ($\frac{1}{2}$ -oz. to a pint of water once a day) after stripping, if absolute cleanliness can be observed with the instruments. If not, it is better not to inject the teats at all, owing to the risk of making matters worse.

Cows affected with inflammation of the udder should not be milked with a milking machine. If possible, a person milking an affected cow should not milk healthy ones, and the milker's hands should be washed in a solution of a disinfectant after every milking, as infection is often conveyed from a diseased cow to a healthy animal by neglecting this precaution.

It is hardly necessary to state that milk from affected cows is unfit for human consumption, and if fed to stock should be well boiled first. Milk from cases of contagious inflammation should be destroyed.

Times of Sunrise and Sunset at Brisbane, 1908.

| DATE. | SEPTEMBER. | | OCTOBER. | | NOVEMBER. | | DECEMBER. | | PHASES OF THE MOON.
H. M. |
|-------|------------|-------|----------|-------|-----------|-------|-----------|-------|-----------------------------------|
| | Rises. | Sets. | Rises. | Sets. | Rises. | Sets. | Rises. | Sets. | |
| 1 | 6.3 | 5.34 | 5.29 | 5.47 | 4.58 | 6.5 | 4.46 | 6.28 | 4 Sept. ☾ First Quarter 6 51 a.m. |
| 2 | 6.2 | 5.34 | 5.28 | 5.48 | 4.57 | 6.6 | 4.46 | 6.29 | 10 " ○ Full Moon 10 23 p.m. |
| 3 | 6.1 | 5.35 | 5.27 | 5.48 | 4.57 | 6.7 | 4.46 | 6.29 | |
| 4 | 5.59 | 5.35 | 5.25 | 5.49 | 4.56 | 6.8 | 4.46 | 6.30 | 17 " ☽ Last Quarter 8 33 " |
| 5 | 5.58 | 5.35 | 5.24 | 5.49 | 4.55 | 6.8 | 4.46 | 6.31 | |
| 6 | 5.57 | 5.36 | 5.23 | 5.50 | 4.55 | 6.9 | 4.46 | 6.32 | 26 " ● New Moon 0 59 a.m. |
| 7 | 5.56 | 5.36 | 5.22 | 5.50 | 4.54 | 6.10 | 4.46 | 6.32 | |
| 8 | 5.55 | 5.37 | 5.21 | 5.51 | 4.53 | 6.10 | 4.46 | 6.33 | 3 Oct. ☾ First Quarter 4 14 p.m. |
| 9 | 5.54 | 5.37 | 5.20 | 5.51 | 4.53 | 6.11 | 4.46 | 6.34 | 10 " ○ Full Moon 7 3 a.m. |
| 10 | 5.53 | 5.38 | 5.19 | 5.52 | 4.52 | 6.12 | 4.47 | 6.35 | 17 " ☽ Last Quarter 1 35 p.m. |
| 11 | 5.52 | 5.38 | 5.18 | 5.52 | 4.52 | 6.13 | 4.47 | 6.35 | |
| 12 | 5.51 | 5.39 | 5.17 | 5.53 | 4.51 | 6.13 | 4.47 | 6.36 | 25 " ● New Moon 4 47 " |
| 13 | 5.49 | 5.39 | 5.16 | 5.54 | 4.51 | 6.14 | 4.47 | 6.36 | |
| 14 | 5.48 | 5.39 | 5.15 | 5.54 | 4.50 | 6.15 | 4.48 | 6.37 | |
| 15 | 5.47 | 5.40 | 5.13 | 5.55 | 4.50 | 6.16 | 4.48 | 6.38 | 2 Nov. ☾ First Quarter 0 16 a.m. |
| 16 | 5.46 | 5.40 | 5.12 | 5.55 | 4.49 | 6.16 | 4.48 | 6.38 | 8 " ○ Full Moon 5 58 p.m. |
| 17 | 5.45 | 5.41 | 5.11 | 5.56 | 4.48 | 6.17 | 4.49 | 6.39 | |
| 18 | 5.43 | 5.41 | 5.10 | 5.56 | 4.48 | 6.18 | 4.49 | 6.40 | 16 " ☽ Last Quarter 9 41 a.m. |
| 19 | 5.42 | 5.42 | 5.9 | 5.57 | 4.48 | 6.19 | 4.49 | 6.40 | |
| 20 | 5.41 | 5.42 | 5.9 | 5.58 | 4.48 | 6.20 | 4.50 | 6.41 | 24 " ● New Moon 7 53 " |
| 21 | 5.40 | 5.43 | 5.8 | 5.58 | 4.47 | 6.20 | 4.50 | 6.41 | |
| 22 | 5.39 | 5.43 | 5.7 | 5.59 | 4.47 | 6.21 | 4.51 | 6.42 | 1 Dec. ☾ First Quarter 7 44 a.m. |
| 23 | 5.38 | 5.44 | 5.6 | 5.59 | 4.47 | 6.22 | 4.51 | 6.42 | 8 " ○ Full Moon 7 44 " |
| 24 | 5.37 | 5.44 | 5.5 | 6.0 | 4.47 | 6.23 | 4.52 | 6.43 | |
| 25 | 5.35 | 5.44 | 5.4 | 6.1 | 4.46 | 6.23 | 4.53 | 6.43 | 16 " ☽ Last Quarter 7 12 " |
| 26 | 5.34 | 5.45 | 5.3 | 6.1 | 4.46 | 6.24 | 4.53 | 6.44 | |
| 27 | 5.33 | 5.45 | 5.2 | 6.2 | 4.46 | 6.25 | 4.54 | 6.44 | 23 " ● New Moon 9 50 p.m. |
| 28 | 5.32 | 5.46 | 5.1 | 6.3 | 4.46 | 6.26 | 4.54 | 6.44 | |
| 29 | 5.31 | 5.46 | 5.1 | 6.3 | 4.46 | 6.26 | 4.55 | 6.45 | 30 " ☾ First Quarter 3 40 " |
| 30 | 5.30 | 5.47 | 5.0 | 6.4 | 4.46 | 6.27 | 4.55 | 6.45 | |
| 31 | ... | ... | 4.59 | 6.5 | ... | ... | 4.56 | 6.46 | |

The Markets.

PRICES FOR FRUIT—ROMA-STREET MARKETS.

| Article. | JULY. |
|--|----------------------|
| | Prices. |
| Apples, per case | 7s. 6d. to 10s. |
| Apples, New England, per packer | ... |
| Apricots, Local, per packer | ... |
| Bananas, Fiji, per case | ... |
| Bananas, Fiji, per bunch | ... |
| Citrons, per cwt. | 11s. 3d. to 11s. 5d. |
| Cumquats, quarter-case | ... |
| Custard Apples, per case | 3s. 6d. to 5s. |
| Gooseberries, per quarter-case | 3s. 6d. to 4s. 9d. |
| Lemons (Lisbon), per case .. | 2s. to 4s. 5d. |
| Lemons, rough, per case | 2s. 6d. to 5s. |
| Mandarins, per case | 1s. 6d. to 5s. |
| Oranges, Queensland, per case | 4s. to 4s. 10d. |
| Passion Fruit (Local), per case | ... |
| Papaw Apples, per quarter-case | 1s. to 1s. 6d. |
| Persimmons, per case | ... |
| Pineapples, rough, per dozen | 3d. to 9d. |
| Pineapples (Ripley's), per dozen... .. | 7d. to 10d. |
| Pineapples, smooth, per dozen | 6d. to 2s. |
| Rosellas, per sugar bag | ... |
| Strawberries, per tray | ... |
| Strawberries, per dozen boxes | ... |
| Tomatoes, per quarter-case | 3s. to 5s. |

SOUTHERN FRUIT MARKET.

| | |
|--|--------------------|
| Apples, local, per bushel case | 9s. |
| Apples, Tasmanian, Eating, per case | 5s. to 11s. |
| Apples, Tasmanian, Cooking, per case | 2s. to 5s. |
| Bananas, Fiji, per case | 15s. 6d. to 16s. |
| Bananas, Fiji, per bunch | 2s. 6d. to 8s. |
| Bananas, Queensland, per case | 12s. to 13s. |
| Bananas, Queensland, per bunch | 2s. to 6s. |
| Bananas, Sugar, Queensland, per double case | 10s. |
| Chillies, per bushel | 8s. 6d. |
| Custard Apples, per case | 3s. to 5s. |
| Gooseberries, per quarter-case | 3s. 6d. to 4s. 9d. |
| Loquats, per case | 7s. |
| Mandarins (Local), per case | 8s. 6d. to 9s. |
| Mandarins, Emperor, per case | 5s. to 6s. 6d. |
| Oranges, Queensland, per case | 6s. 6d. to 7s. 6d. |
| Oranges (Local), per case | 8s. |
| Oranges, Queensland, Navel, per case | 10s. |
| Passion Fruit, per half-case | 4s. 6d. |
| Pears, Victorian, per bushel case | 20s. |
| Pears, Tasmanian, per half-bushel case | 6s. |
| Pineapples, Queensland (smooth), per dozen | 3s. 6d. to 5s. |
| Pineapples, Queensland (Ripley's), per dozen | 4s. to 4s. 6d. |
| Pineapples, Queens, per dozen | 3s. 6d. to 5s. |
| Pineapples, Queensland, common, choice, per dozen | 3s. to 4s. |
| Pineapples, Queensland, medium, per dozen | 2s. 6d. |
| Strawberries, Queensland, per three-quart tray | 4s. 6d. to 5s. |
| Strawberries, Queensland, small, per three-quart tray | 2s. to 3s. |
| Tomatoes, Queensland, choice (coloured), per box | 2s. 6d. to 4s. 6d. |
| Tomatoes, green, per quarter-case | 2s. 6d. to 3s. 6d. |

Orchard Notes for October.

By ALBERT H. BENSON, M.R.A.C.

THE SOUTHERN COAST DISTRICTS.

As October is often a dry month throughout the greater part of the State, one of the most important duties of the fruit-grower is to keep his orchard or vineyard in a thorough state of cultivation, thus retaining the moisture in the soil that is essential to the setting and development of the fruit crop. As long as the land is level, one cannot over-cultivate, as there is no danger of the soil washing, but when the orchard is on a hillside heavy thunderstorms, which may occur during the month, are very apt to cause heavy washaways of soil if the land is kept in the high state of tilth necessary to retain moisture. In this case, the cultivation should always be across and not up and down the face of the hill, and where the soil is of such a nature that it will wash badly then blocks, consisting of a row or two of a growing crop or of light timber, brush-wood, or even a body of weeds or heavy mulching, should be provided, such blocks to follow the contour of the orchard. If dry, and water for irrigation is available, citrus trees will be the better for a thorough watering during the month. Give the trees a good soaking, and follow the irrigation by systematic cultivation, as this is much better than constant surface watering, as practised by the Chinese. Examine the orchard and vineyard carefully for pests of all kinds. When young trees are showing signs of scale insects, cyanide same; when leaf-eating insects of any kind are present, spray the plants that are being attacked with Kedzie's mixture. Look out carefully for black spot and oidium in grape vines, using Bordeaux mixture for the former and sulphur for the latter. When using sulphur, see that you get a fine sample—viz., one in which the particles of sulphur are in a very fine state—as the finer the sulphur the better the results. Do not apply the sulphur in the early morning, but during the heat of the day, as it is the sulphur fumes, not the sulphur, which do the good. A knapsack sulphurer is the best machine for applying sulphur to grape vines, trees, or plants.

Examine any late citrus fruits or early summer fruits for fruit fly, and take every precaution to keep this great pest in check now, as, if fought systematically now, it will not do anything like the same amount of damage later on as if neglected and allowed to increase unchecked. October is a good month for planting pineapples and bananas. Be sure and have the land properly prepared prior to planting, especially in the case of pineapples, as the deeper the land is worked and the better the state of tilth to which the surface soil is reduced the better the results, as I am satisfied that few crops will pay better for the extra work involved than pines.

TROPICAL COAST DISTRICTS.

As the fruit fly usually becomes more numerous at this time of year, the netting of bananas is essential. Banana and pineapple plants may be set out, and the orchards should be kept well tilled, so as to have the land clean and in good order before the heavy summer growth takes place.

All the spring crop of citrus fruit should be now marketed, and the trees, where necessary, should be pruned and sprayed, and the land be well ploughed. The ploughing should be followed by harrowing and cultivating, so as to get the surface of the land into good order. Granadillas and pawpaws should be shipped to the Southern markets, as, if care is taken in packing, and they are sent in the cool chamber, they will carry in good order. These fruits should not be gathered in an immature condition, as, if so, they will never ripen up

properly. They should be fully developed but not soft, and if gathered in this condition, carefully handled, and packed and shipped in cool storage, they will reach the Southern markets in good condition, and, once they become more commonly known, will meet with a ready sale.

SOUTHERN AND CENTRAL TABLELANDS.

In the Stanthorpe district, the spraying of apple and pear trees for codlin moth will have to be carefully carried out, the best spray being the arsenical mixture known as "Kedzie's," which has been described from time to time in this Journal.

Where fungus diseases, such as powdery mildew, &c., are also present, Bordeaux mixture should be combined with the arsenical spray.

The vineyard will require considerable attention, as the vines must be carefully disbudded, and any signs of oidium or black spot should be checked at once. Look out for late spring frosts, and, if possible, try the effect of smudge fires producing dense smoke for preventing any damage.

Keep the orchards and vineyards well cultivated, as it is of the utmost importance to keep the moisture in the soil at this time of the year if a good fruit crop is to be secured.

In the warmer districts cultivation is all-important, and where irrigation is available it should be used for both fruit trees and vines, a thorough soaking followed by systematic cultivation being given.

Farm and Garden Notes for October.

FIELD.—With the advent of warmer weather and the consequent increase in the soil temperature, weeds will make great headway if not checked; therefore our advice for last month holds good with even greater force for the coming month. Earth up any crops which may require it, and keep the soil loose among them. Sow maize, sorghum, setaria, imphee, prairie grass, panicum, pumpkins, melons, cucumbers, marrows. Plant sweet potatoes, yams, peanuts, arrowroot, turmeric, chicory, and ginger. Coffee plants may be planted out. There are voluminous articles in previous Journals giving full instructions how to manage coffee plants, from preparing the ground to harvesting the crop, to which our readers are referred. The planting of the Sisal Agave and the Fourcroya may be proceeded with at any time of the year, but the best time is in spring and beginning of summer, when warm weather and good showers will enable the young plants to root quickly and become firmly established before the winter. The demand for the fibre is constantly increasing, and the supply does not nearly overtake the demand; hence prices keep high, and the outlook for the future is very promising. See our instructions in "The Sisal Industry in Queensland," obtainable free by intending planters on application to the Under Secretary, Department of Agriculture and Stock. Plant only on dry or well-drained soil. Cotton may still be sown.

KITCHEN GARDEN.—Our notes for this month will not vary much from those for September. Sowings may be made of all kinds of vegetables. We would not, however, advise the sowing of cauliflowers, as the hot season, fast approaching, will have a bad effect on their flowering. French beans, including butter beans, may be sown in all parts of the State. Lima and Madagascar beans should also be sown. Sow the dwarf Lima beans in rows 3 feet apart with 18 inches between the plants. The kitchen garden should be deeply dug and the soil reduced to a fine tilth. Give the plants plenty of room, both in sowing and transplanting, otherwise the crops will be drawn and worthless. Thin out melon and cucumber plants. Give plenty of water and mulch tomato plants planted out last month. Asparagus beds will require plentiful watering and a good top-dressing of short manure. See our instructions in "Market Gardening," obtainable on application to the Under Secretary, Department of Agriculture and Stock. Rosella seeds may be sown this month. No farm should be without rosellas. They are easily grown, they bear heavily, they make an excellent preserve, and are infinitely preferable to the mulberry for puddings. The bark supplies a splendid tough fibre for tying up plants. The fruit also makes a delicious wine.

FLOWER GARDEN.—The flower garden will now be showing the result of the care bestowed upon it during the past two months. The principal work to be done this month is the raking and stirring of the beds, staking, shading, and watering. Annuals may be sown as directed for last month. Plant chrysanthemums, gladiolus and other bulbs, such as tuberoses, crinum, ismene, amaryllis, paneratium, hermocallis, hippeastrum, dahlias, &c. Water seedlings well after planting, and shade for a few days. Roses should now be in full bloom. Keep free from aphids, and cut off all spent flowers. Get the lawn-mower out and keep the grass down. Hoe the borders well and trim the grass edges.

Agriculture.

THE JACKSON POTATO-DIGGER.

During the month of August several trials of the Jackson potato-digger were carried out, and all went to prove the perfect adaptability of the machine for the work it is intended to do. At the last demonstration there was a large assemblage of farmers and others interested in agriculture at Mr. Mullin's farm, at Chelmer. The potato crop was light, with a large proportion of small potatoes. As the machine, drawn by two medium plough horses, passed through the rows, it was seen that every potato was laid on the surface, which was left smooth and even behind it. The work was done so expeditiously that it was facetiously remarked that an army of pickers-up would be required to keep pace with it. Mr. Jackson claims that his machine will take up the crop from 6 acres a day, and those present thought it would even do more than this. It is the inventor's intention to form a small company to enable him to establish special works for building the machines and placing them on the market. Already an application has come from New Zealand for the agency for the machines, which, by the way, have been patented or, rather, protected in that colony and throughout the Commonwealth. With the advent of this digger, the labour of digging a potato crop is entirely done away with. It now only needs another machine to pick up and bag the potatoes to make the business a mere pastime.

ON PLOUGHING.

We are all familiar with the phrase, "A little farm well tilled." That short sentence describes the modest wish of everyone who launches into an agricultural career. Having got the "little farm," the wish expands into a "big farm," and, by keeping the "little farm" well tilled, the "big farm" may become an accomplished fact. Tillage in agriculture is a most important operation, its object being, of course, to bring the ground into that state of tilth best suited to the growth of grass and crops. In order to obtain this tilth, the employment of many kinds of implements are required, and the first of these is the plough. It is not now regarded as the most important, because the cultivators, grubbers, disc harrows, and similar implements reduce the ground to a proper condition for a seed bed, even if the ploughing has been badly done. There can be no doubt, however, that the plough is a very important machine in agriculture, and must continue to be so till the end of time. It is the most ancient implement known, but within the last century it has been improved very much indeed—in fact, there are few machines which have been more altered in its appearance and its work. Wood has been replaced by iron; steel has taken the place of iron; and mechanical laws have been applied to make the implement easier to pull and more effective in its work. As the years go on, new principles are being applied, and there are now quite a number of different kinds of ploughs on the market and in general use. There are the ordinary single and double furrow ploughs (swing ploughs are rarely seen nowadays), digging ploughs, subsoil ploughs, gang and stump-jumping ploughs, one-way or hillside ploughs, multiple ploughs, and, last of all, disc ploughs. Some of these, as their names denote, are special-purpose ploughs, and with these there is no necessity to deal in the present article.

Single-furrow ploughs are not used except on small holdings and in gardens. They are now fitted with wheels, which keep them steady and at a uniform depth. Swing ploughs are balanced by the ploughmen, and require more skill in their management than wheeled ploughs. Single-furrow ploughs are often used for opening lands or striking out, and also for finishing. They are also used for such work as potato-planting, although the double-furrow is also used.

The double-furrow plough has for a long time been the principal kind of plough used in New Zealand. It is now in some districts being superseded by the treble-furrow, which is in reality a double-furrow with another beam and mould-board attached. The principle is exactly the same. The idea of the extra furrow is to give the larger teams, which must be used in cultivating and drilling, sufficient work to do when ploughing. It is not so long ago that three and four horse teams were in vogue. Nowadays the five and six horse team is in more general use, because of the extra strength required to haul up-to-date cultivators, disc harrows, and drills. Then, again, digger and disc ploughs are being used very largely, and these demand larger teams than the old four-horse team.

A plough is, in reality, a combination of instruments fastened to a beam. The most important of these instruments are the coulter or skeith, the share or sock, the mould-board or breast, and the bridle. Other parts are added, according to the kind of plough desired, but usually there is a lever and a steering-rod. It is not necessary for me, I suppose, to describe the function of each of these parts. Before describing the different kinds of work done by several kinds of ploughs and the uses of each, I will give a few of the terms used in ploughing.

There are two principal methods of ploughing—viz., in lands, and round-and-round. The former method is used on flat land and on undulating downs, while the latter is used in steep localities.

With practice, a perfectly straight furrow may be maintained, and with a little patience almost any plough may be set to cut and throw all its furrows alike and evenly. The turning-points at the ends of the "lands" are called "headlands," and it is important that youths starting to plough should be taught to keep their furrows square with the headland, and the headlands themselves the same width right through. A plough cannot do good work unless it is kept in good order, and every ploughman should know how to keep his plough wheels packed and his skeiths running true. For skeiths, I find the "cones" the best kind of axle to use. Skeiths should not be used among stones, nor should they be used in frosty weather, as they are liable to get damaged very seriously. The ordinary double and treble furrow is mostly useful for ploughing in the autumn, when it has to be fallow through the winter for turnips or oats in the spring. Lea ploughed for wheat should be turned the round-and-round method. In this case it is a lazy man's method. It continually moves the land towards the fences, while denuding the finish in the middle of the paddocks of soil. This applies also, of course, to ploughing steep country round-and-round, but it is unavoidable in this instance. By ploughing in lands, good drainage may be effected; the land can be effectually cross-ploughed, and the land can be kept fairly even and level by altering the place for striking out and finishing. The crown of the land is the high ridge formed by marking out, or striking out, as it is usually called. This marking out is called "feeding." The open furrow between the lands is called the "finish." The furrows may be either gathered towards the crown of the land, or they may be scattered, till an open furrow or finish results. In gathering, the team pulls to the right; "gee-back" is the command given by the ploughman. In scattering, the horses turn to the left, or "come here," as their driver would

say. There are also several kinds of furrows, chief among which is the rectangular furrow, made by a flat-cutting share and an upright coulter or skeith; a high-cut furrow, obtained by using a share raised on the wing side, and a skeith or coulter, cutting a furrow at an angle. The digger plough has a furrow peculiarly its own, which I will attempt to describe later on.

I have said that the single-furrow plough is very frequently used for marking out and finishing lands. This operation may, however, be done equally well with a double or treble furrow plough; and there are very few who now trouble with a single furrow for marking out. Some prefer three horses for striking out with a double furrow, but it may be done, with practice, with any team. Now that the seed is usually drilled instead of being sown broadcast on the furrow, there is not so much used, from the utility point of view, for straight ploughing. Ploughing matches are going out of fashion, except in parts of South Canterbury and Southland, but it would be well if our agricultural and pastoral societies took the matter up.

Stubbles ploughed for autumn oats should be ploughed with an ordinary double-furrow or with one of the many kinds of multiple ploughs now being used. These multiple ploughs are principally useful for stubble work, and for turning over land out of turnips for either rape, grass, or oats. Oats are shallow-rooted, and therefore the digger may be reserved for the deeper-rooted wheat. Sometimes a mistake is made by ploughing too deeply for oats and for turnips. A dry season comes, and the roots fail to reach the subsoil. Had the land been ploughed fairly shallow, say 3 or 4 inches, the roots would have reached the stored-up moisture, and would have given a good crop. Moreover, being shallow-rooted, they get the benefit of animal droppings and decaying vegetation when the furrow is fairly shallow, and also of the work of soil bacteria, which are always more active near the surface than lower down in the soil.

I have mentioned digger ploughs several times, and will now endeavour to describe them and their functions. They are daily coming into more extended use, and in parts of Canterbury and Southland are thought very highly of indeed. Personally, I may say that some ten years ago I tried them, but was disappointed at the result, and gave them up. Some half-dozen years ago we had some very wet seasons, and I found that the digger would work where the ordinary plough would not. They left the ground in good condition for sowing grain on, and the crops did well. The secret of the whole matter was that the ploughs were being worked at too great a depth when they were previously being used. The breast or mould-board has a kind of shin on it which acts as a coulter. A skim coulter takes the place of the usual skeith or long coulter. This skim coulter assists in cutting the furrow, but most of the vertical cutting is done by the shin on the mould-board. The horizontal cutting is done by a broad share, which forms the forepart of the mould-board. The shape of the mould-board is different to that on the plain double furrow. It is much shorter, is slightly disked, and then takes an outside curve. The earth is thrown outwards and over, and is not compressed or packed. It is left in much the same condition as it would be if dug with a spade. The land lies loosely, and frost can get into it. The water runs through it, and there is no solid furrow to be worked down. As I have already indicated, the digger can be worked in stiff, clay soils in wet weather, when the plain plough would have to remain idle. It does a great amount of after cultivation. A stroke of the tines or discs before the drill, and a couple of strokes after, is all that is required, where in other cases scarifiers and rollers would have to be used. The digger buries grass and weeds deeply down, so that they do not get a chance to grow through the furrows. Moreover, the vegetation gets rotten about the time the ear of corn is filling, and helps materially to form food for the plant

at a time when it requires it. There is, as already stated, a danger of turning up too much sour land, so that the seed does not grow away quickly. This must, of course, be guarded against. The plough will plough no deeper than where it is set. I know of people who quickly discard the digger because they cannot make them do good work. The fault is, very often, that an attempt is being made to turn over a furrow too wide for the depth. The result is that the desired crumbling, feathery state of the land is not attained. As a rule, people do not, on clay lands, desire to plough deeper than 6 or 7 inches. Roughly speaking, 1 inch of depth requires 2 inches of width. Thus a furrow 6 inches deep should not have a greater width than 12 inches. A furrow 6 inches by 15 inches would be a failure, in my experience. In marking out, the front wheel should be lowered in order that the front plough shall not plough too deeply, and throw up too high a ridge. In finishing, much the same method is adopted as with an ordinary plough. It is well to repeat that the first time of ploughing must not be too deep. The soil on the top after ploughing is all brought up from the bottom of the furrow. A paddock may easily be spoiled for a year or two because of too deep ploughing with the digger. They are often spoken of as horse-killers, but, as a matter of fact, they are not more so than an ordinary plough. They certainly require more strength, but they will turn over 4 acres a day, where an ordinary plough will only do between 3 and 3½ acres in the day. In ground where they have never been used before, the work is harder than on land where they are frequently used, because there is a certain amount of subsoil to be turned up for the first time. In ordinary cases five horses will work them as easily as four will work a plain plough, and, as I have said, they will do from ½-acre to 1 acre more work. The mould-board is shorter, but there is less friction, because it has only to clear its way, whereas a plain plough has to be dragged through the ground like a wedge.

I shall conclude by saying something about the latest pattern of plough—the disc plough. They are coming into use slowly, and are excellent for certain kinds of work on certain kinds of land. For cross-ploughing in autumn they do good work, breaking up the ground thoroughly, so that but little after-work is needed to make a good seed bed. They do well on stubbles in the autumn, and get over a lot of ground in a day. They are made somewhat on the principle of the disc harrow, and require more power than an ordinary plough. If they are set narrow, and the ground is level, four horses will work them on stubble, turnip land, or fallow, and five on lea land. Generally speaking, however, they require five horses for the former kind of land and six on the latter, especially if the ground is hilly. They are not suitable for turnip land which has been tramped and poached by stock in the winter, as they leave the ground too lumpy and rough. It is on the twitchy land that the disc plough is most serviceable. In fact, it will throw about land infested with couch, yarrow, and other plants with creeping roots in splendid style, where a plain furrow plough will scarcely touch it. Paddocks which have been given up as unworkable, by reason of a mat of twitch or couch, have been brought into cultivation again by the disc plough. It throws the furrows in the air, and leaves them lying up to the sun and weather in such a manner that the plants are half-killed before after cultivation is started upon. Moreover, the furrow, instead of being packed hard, so that no disc harrow or cultivator can touch it, is left so that these implements can smash them about splendidly. Some farmers break up twitchy land with the ordinary plough, and then put the disc plough on to cross-plough, with very satisfactory results. In my opinion, the disc plough is an implement that materially reduces the fear that twitch and couch, and such like weeds, will ultimately get possession of our arable lands.—A New Zealand Farmer, in "The New Zealand Farmer."

Dairying.

THE DAIRY HERD, QUEENSLAND AGRICULTURAL COLLEGE,
GATTON.

RECORD OF COWS FOR MONTH OF AUGUST, 1908.

| Number. | Cow's Name. | Breed. | Date of Calving. | Total | Average | Commer- | Remarks. |
|---------|----------------|--------------------|------------------|-------|-----------|---------|-----------------|
| | | | | Milk. | Test, | cial | |
| | | | | Lb. | Per cent. | Butter. | |
| 1 | Sue ... | Grade Shorthorn | 25 May, 1908 | 799 | 5.0 | 44.74 | |
| 2 | Peewee ... | Holstein-Sh'rth'rn | 20 May " | 932 | 4.0 | 41.75 | |
| 3 | Grace ... | Shorthorn | 30 May " | 822 | 3.2 | 29.46 | |
| 4 | Hetty ... | Ayrshire-Sh'rth'n | 20 Mar. " | 541 | 4.3 | 26.05 | |
| 5 | Winnie ... | Shorthorn | 8 April " | 604 | 3.8 | 25.70 | |
| 6 | Ruby ... | Ayrshire | 21 July " | 612 | 3.7 | 25.36 | |
| 7 | Carrie ... | Jersey | 16 Jan. " | 518 | 4.3 | 24.94 | |
| 8 | Remit ... | Grade Holstein | 6 Aug. " | 666 | 3.1 | 23.12 | |
| 9 | Glen ... | Shorthorn | 10 Feb. " | 402 | 5.0 | 22.51 | |
| 10 | Rhoda ... | Grade Shorthorn | 28 Mar. " | 540 | 3.7 | 22.37 | |
| 11 | Lark ... | Ayrshire | 6 June " | 495 | 4.2 | 22.28 | With first calf |
| 12 | Cocoa ... | Jersey | 10 Nov., 1907 | 439 | 4.5 | 22.12 | |
| 13 | Nettle ... | Shorthorn | 14 May, 1908 | 583 | 3.3 | 21.54 | |
| 14 | Lady Loch... | Ayrshire | 21 June " | 548 | 3.4 | 20.86 | With first calf |
| 15 | Lubra ... | " | 5 June " | 519 | 3.7 | 20.50 | " " |
| 16 | Madge ... | Grade Holstein | 16 June " | 434 | 4.0 | 19.44 | " " |
| 17 | Mona ... | " | 20 Oct., 1907 | 443 | 3.7 | 18.35 | |
| 18 | Damsel ... | Holstein | 19 Feb., 1908 | 462 | 3.5 | 18.11 | |
| 19 | Lalla ... | " | 23 July " | 467 | 3.4 | 17.78 | With first calf |
| 20 | Honeycomb | Shorthorn | 23 Aug., 1907 | 334 | 4.7 | 17.58 | |
| 21 | Nancy ... | " | 7 May, 1908 | 473 | 3.3 | 17.48 | With first calf |
| 22 | Nellie II. ... | " | " | 422 | 3.5 | 16.54 | |
| 23 | Patch ... | " | 14 Sept., 1907 | 352 | 4.1 | 16.16 | |
| 24 | College Lass | Ayrshire | 14 Sept. " | 320 | 4.3 | 15.41 | |

The cows were fed on ensilage, 40 lb. per day, and allowed to run in different poorly grassed paddocks.

TO MAKE SMALL CHEESE.

It is difficult to give necessary directions for successfully making cheese to one not accustomed to curd mixing, writes a practical cheese-maker in an exchange. Until an operator has gained experience by practice, the result of making cheese from such printed directions cannot be guaranteed. But some principles and rules may be given which ought to prove a fairly satisfactory guide to experimental practice, if good judgment be used in their application.

We will assume that we use 500 lb. of milk, testing 4 per cent. fat. If the quantity of milk used be more or less, the amount of rennet, salt, &c., should be proportionate. The night's milk should be well aired, cooled, and kept at a temperature of 65 degrees.

Mix the night's milk and the fresh morning's milk in a vat or tub not more than 20 inches deep; 15 inches will be better, as the curd will cook more thoroughly, and with less danger of packing in the bottom. A very simple and effective way of heating the milk is by using two small cans, 7 inches in

diameter, and high enough to extend above the surface of the milk. Fill these with hot water, and move them around in the vat until the milk is warmed to 84 degrees.

When coloured cheese is desired, add $\frac{1}{2}$ -oz. of some standard cheese colour mixed with a pint of water, and stir thoroughly into the milk. Put $1\frac{1}{2}$ oz. of rennet extract into half a pint of cold water; do not use warm water or allow the mixture to become warm, and add to the milk, stirring for two minutes. The mass will coagulate and be ready to cut in about twenty-five minutes. The curd is ready to cut when it will break clean over the finger. If no cheese knife is at hand, use a piece of galvanised woven-wire netting about 6 by 15 inches, with a $\frac{1}{2}$ -inch mesh, drawing it through the mass lengthwise and crosswise. This, of course, is a crude way of cutting, but it will serve the purpose of breaking the mass and starting the whey. Keep the mass stirred, so the small cubes will remain separate. The heating cans should be again used in ten minutes. Keep them moving around in the vat, and also move the curd well, in order to prevent any portion of the latter from becoming overheated. When the thermometer registers 98 degrees, take out the cans and stir the mass until the cubes do not readily adhere; then stir occasionally until ready for the mould.

This point is not easily determined. The old way of deciding this was to take off the whey when the curd squeaks between the teeth—by no means a bad method. It would be better to depend upon the feeling and the smell, but beginners may use the first rule mentioned, aided by the feeling. Take a handful of curd and squeeze it hard. If it has an elastic feeling, showing it to be dried out, then drain off the whey. Keep the curd well stirred until it is cool and free from moisture; this will require about half an hour.

It may be more convenient after removing the whey to place the curd in some other receptacle, where the moisture will drain out more easily and quickly—either a slanting rack or a rack with a cloth over it. Add 1 lb. of clean salt, thoroughly mix with curd, and wait fifteen minutes before pressing. Two hoops 11 inches in diameter and 14 inches deep, or one hoop 14 inches in diameter and 14 inches deep, will be needed; or, if small, 12-lb. cheeses are wanted, get four 7-inch hoops 12 inches deep. The amount of cheese produced will depend upon the fat content of the milk. It is safe to count on 2'65 lb. of cured cheese for each 1 lb. of fat in the milk, if the milk contains anywhere from $3\frac{1}{2}$ to $4\frac{1}{2}$ lb. butter fat.

Take a cheese bandage to fit the hoop and long enough to project 1 or 2 inches at each end. Place a round piece of cotton cloth at the bottom of the hoop as a temporary cap or cover; then put in the bandage with the lower edge turned in about 1 inch on the top of the bottom cap and the upper edge turned back over the top of the hoop. Fill in the curd, fold in the upper edge of the bandage, put on as a top cover a piece of cotton cloth similar to the one on the bottom, and place in the press. For pressing, use a $1\frac{1}{2}$ -inch screw set in a frame and provided with means for turning, if a better press is not available. The rind will not form and the whole operation will be a failure, if sufficient pressure is not applied.

After an hour take out of the press, adjust and smooth the bandage, covering the edges nicely, and put on cap cloths of same material as the bandage, with the cotton press cloths on the outside of these. Put the cheese back into the hoop with a strong, round, wooden follower closely fitting inside the hoop on top of the cheese, and press again the following day. Then take out the cheese, remove the press cloths, and place it for curing on a shelf in a room having an even temperature of about 60 degrees. It should cure in three or four weeks. The resulting cheese will be presentable and eatable, if no gross errors occur in the making.—Exchange.

BUTTER FACTORIES IN QUEENSLAND, 1908.

| District. | Name of Factory or Company. | Proprietary or Co-operative. |
|---------------------------|---|------------------------------|
| Brisbane and East Moreton | Lowood Creamery Company, Limited, Adelaide street; and at Beau Desert | Proprietary |
| " | Brisbane Butter and Ice Company, South Brisbane | " |
| " | Silverwood Dairy Factory Company, Limited, Roma street; Brisbane; and at Terror's Creek | " |
| " | Queensland Meat Export and Agency Company, Pinkenba | " |
| " | South Queensland Co-operative Dairy Company, Limited, Kingston | Co-operative |
| " | Logan and Albert Co-operative Dairy Company, Beaudesert | " |
| " | Caboolture Co-operative Dairy Company, Limited, Caboolture | " |
| " | Stanley River Co-operative Company, Limited, Yatesville | " |
| " | Maleny Co-operative Dairy Company, Limited, Maleny, <i>via</i> Landsborough | " |
| Ipswich and West Moreton | C. E. Springall, Stanley street, South Brisbane | Proprietary |
| " | F. G. Springall, North Ipswich | " |
| " | Pommer Bros. | " |
| " | F. W. Linning, Kirchheim | " |
| " | J. L. Frederick, Marburg | " |
| " | Siemon and Sons, Wallooa | " |
| " | Dick Bros., Purga | " |
| " | Patrick Sherlock, Pine Mountain | " |
| " | Queensland Farmers' Co-operative Company, Limited; Factor es at Booval, Laidley, Grantham, and Boonah | Co-operative |
| " | Silverwood Dairy Factory Company, Gatton | Proprietary |
| " | Esk Co-operative Dairy Company, Limited, Esk | Co-operative |
| Darling Downs | Silverwood Dairy Factory Company, Limited; Factories at Toowoomba and Warwick | Proprietary |
| " | The Downs Co-operative Dairy Company, Limited, Toowoomba | Co-operative |
| " | Crow's Nest Dairy Company, Limited, Crow's Nest | " |
| " | Goombungee Co-operative Dairy Company, Limited, Goombungee | " |
| " | Pittsworth Dairy Company, Limited, Pittsworth | " |
| " | Oakey Dairying Company, Limited, Oakey | " |
| " | Mount Bismarck Co-operative Dairy Company, Mount Bismarck | " |
| " | Pilton Dairying Company, Limited, Upper Pilton, Clifton | " |
| " | Clifton Co-operative Dairying Company, Limited, Clifton | " |
| " | Warwick Butter and Dairying Company, Limited; Factories at Warwick and Allora | " |
| " | Dalby Butter Factory, Dalby | Proprietary |
| Maranoa | Macfarlane and O'Connor, Roma | " |
| Wide Bay and Burnett | Wide Bay Co-operative Dairy Company, Limited, Gympie | Co-operative |
| " | Tiaro Co-operative Dairy Company, Limited, Tiaro | " |
| " | Maryborough Co-operative Dairy Company, Limited; Factories at Maryborough and Kingaroy | " |
| " | Nanango Co-operative Dairy Company, Limited, Nanango | " |
| " | Bundaberg Co-operative Dairy Company, Limited, Bundaberg | " |
| Rockhampton | Port Curtis Co-operative Dairy Company, Limited, Gladstone | " |
| " | Rockhampton District Co-operative Dairy Company, Rockhampton | " |
| " | Archer Bros., Gracemere, Rockhampton | Proprietary |
| " | Conaghan Bros., Rockhampton | " |
| " | C.Q. Meat Export Company, Lake's Creek, Rockhampton | " |
| North Queensland | Ayr Co-operative Dairy Company, Limited, Ayr | Co-operative |
| " | Cairns-Atherton Dairying and Ice Company, Cairns | Proprietary |

CONDENSED MILK FACTORIES.

Nestle and Anglo-Swiss Condensed Milk Company.—Factories at Toogoolawah, Esk; Trelawny, Harrisville.

Standard Dairy Company, Wyreema and Colinton.

Gowrie Dairy Supplies, Gowrie.

CHEESE FACTORIES.

Silverwood Dairy Factory Company, Limited; head office, Roma street, Brisbane. Factories at—Yangan; Tannymorel; Milmerran, *via* Pittsworth; Forest Plain, *via* Allora; Lord John Swamp, *via* Warwick.

Lowood Creamery Company, Limited; head office, Adelaide street, Brisbane. Factories at—Elbow Valley, *via* Warwick; Greymare, *via* Warwick; Yangan; Inglewood

Donald McIntyre, Goombungee. Factories at Goombungee and Mount Darry, *via* Goombungee.

Greenmount Co-operative Dairy Company, Limited, Greenmount.

Ramsay Co-operative Dairy Company, Limited, Cambooya.

Back Plains Co-operative Dairy Company, Limited, Back Plains, Clifton.

Pittsworth Co-operative Dairy Company, Limited, Pittsworth.

Donald Mackintosh, Glencairn, *via* Pittsworth.

IXL Dairy Company, Eton Vale, *via* Greenmount.

Southbrook Co-operative Dairy Company, Limited, Southbrook.

Daly Bros., Quinalow, *via* Jondaryan

Rosevale Cheese Factory, Rosevale, *via* Rosewood.

MEAT EXPORTING FACTORIES.

Brown and Company, Elizabeth street.

Queensland Meat Export and Agency Company, Limited. Factories at—Pinkenba, Townsville, Burketown.

Baynes Bros., South Brisbane (Factory at Queensport).

Birt and Company, Limited, Moorarce, near Brisbane.

John Cooke and Company, Redbank Freezing Works, Redbank, near Brisbane.

Gladstone Meat Works of Queensland, Gladstone.

Central Queensland Meat Export Company, Lake's Creek, Rockhampton.

Bergl Australia, Limited, Merinda, Bowen.

North Queensland Meat Export Company, Limited, Townsville.

Burdekin River Meat-preserving Company, Limited, Townsville.

BACON FACTORIES.

J. C. Hutton Proprietary, Limited, Zillmere (Brisbane office, Roma street, Brisbane).

Foggitt, Jones, and Company, Oxley (Brisbane office, Turbot street, Brisbane).

Chapman and Sons, Murphy's Creek

Kimmer and Reid, Toowoomba.

Queensland Meat Export and Agency Company, Limited, Pinkenba.

GUERNSEY CATTLE.

Whilst volumes are written in Queensland journals on the Ayrshire, Jersey, Shorthorn, and Holstein breeds of dairy stock, little is heard of the Guernsey; yet these latter closely resemble the Jerseys in their general conformation and appearance. Still, this breed has never enjoyed, throughout Australia, the same popularity as the others above mentioned. A few years ago the Government of New South Wales introduced some bulls and cows of this breed into that State; and a strong demand set in by farmers, desirous of improving their dairy herds, for Guernsey bulls, and, for a time, their introduction met with marked success. Last year a number of Guernseys were imported into New South Wales from England. They were rich strains of butter-producing stock, with pedigrees from herds which had been bred for years for milk and butter.

The breed originated in another of the Channel Islands known as the Island of Guernsey, and has practically the same origin and history as the Jersey. In the development of the Guernseys, however, more of the original characteristics of the parent stock from Normandy have been preserved. At present, however, the Guernseys closely resemble the Jerseys in their general conformation and appearance.

The Guernseys were first introduced into the United States, in numbers, in about 1850, being grouped together with the Jerseys at that time under the name of "Alderneys." Between 1870 and 1875 the Guernsey was recognised as a distinct breed in the United States. The head of the Guernsey is long, the neck slender, the body large and deep, and the flanks thin. The colour is light-yellow and orange or buff predominating, with considerable white in patches on the body and legs. Dark colours approaching brown are seen on some cows and more frequently on bulls. The muzzle is most always buff or flesh colour. The horns are small, curved, and waxy, often showing a rich yellow at the base. One of the distinguishing characteristics of the Guernsey is the large secretion of yellow colouring matter throughout the skin, but especially where the hair is white around the ears, eyes, and udder. The udder and teats are well shaped. While the Guernsey is of a nervous temperament, the cows are gentle under proper management, and the bulls are probably less likely to become vicious than Jersey bulls.

The Guernseys are economic feeders and excellent butter-producers, the milk often showing from 5 to 6 per cent. of fat. They are especially recommended by Alvord and others for butter cows and for the production of market milk, where quality secures a high price. They show great power of assimilating feed. At the butter tests and milking trials at the Royal Counties Show, Southampton, England, in June last, one Guernsey cow, eight Jerseys, two Lincoln Reds, and two Shorthorns were entered for the butter test, with the following results:—

The animals were milked out at 5 p.m. on Thursdāy, 24th June, and the milk of the next twenty-four hours taken for the test at 7 a.m., and again at 5 p.m., after which the milk was separated.

Churning commenced on Saturday, at 6'50 a.m., and was concluded at 9'13, the awards being made known at 10'30 a.m. The butters were of high merit.

The prizes were awarded as follow:—First prize, £10, and gold medal to the Marquis of Winchester's Wench, 47'50 points; silver medal to Mr. J. Carson's Mary's Beauty, 36'95 points; bronze medal to Mr. J. Carson's Blue Poppy, 35'20 points; second prize, £7, to Mr. Dampney's Shorthorn cow Lady, 45'00 points; third prize, £3, to Mr. Williams' Shorthorn cow Bessie, 37'75 points. Mr. Carson's Blue Poppy was awarded the £1 butter prize for the best butter in the test.

The averages are as follows:—

| No. | Breed. | Days in Milk. | Milk. | Butter. | Ratio. | Points. |
|-----|---------------------|---------------|----------------------------------|----------------------------------|--------|---------|
| | | | Lb. oz. | Lb. oz. | Lb. | |
| 8 | Jerseys | 107 | 31 2 ³ / ₄ | 1 11 ¹ / ₂ | 18·11 | 34·01 |
| 2 | Shorthorns | 21 | 65 7 | 2 9 ¹ / ₄ | 22·28 | 41·37 |
| 2 | Lincoln Reds | 57 | 59 14 | 2 0 | 29·82 | 34·72 |
| 1 | Guernsey | 8 | 38 14 | 2 1 ¹ / ₂ | 18·56 | 33 50 |

MILK YIELD TEST.

Eleven animals were entered for the above trials; two were absent; so that nine actually competed. Of these, three were Jerseys, three Shorthorns, two Lincoln Reds, and one Guernsey.

The twenty-four hours' milk was taken, and small samples extracted morning and evening, by the Gerber process, for the purpose of ascertaining the amount of butter fat.

The first prize was won by Lord Rothschild's Shorthorn cow, Darlington Cranford 5th, with 89·45 points; Mr. Evens' Lincoln Red, Burton Milker, second; with 82·85 points; and Mr. Dampney's Shorthorn cow, Lady, third, with 80·90 points. The remaining animals competing all passed the standard, and were awarded commended cards. The averages of the breeds are as follow:—

| No. | Breed. | Days in Milk. | Milk Yield. | Butter Fat. | Points. |
|-----|---------------------|---------------|-------------|-------------|---------|
| | | | Lb. oz. | | |
| 3 | Shorthorns | 33 | 67 14 | 3·76 | 83·50 |
| 3 | Jerseys | 113 | 33 6 | 5·40 | 62·27 |
| 2 | Lincoln Reds | 57 | 59 14 | 3·27 | 75·57 |
| 1 | Guernsey | 8 | 38 14 | 4·80 | 58·07 |

THE QUEENSLAND BEE-KEEPERS' ASSOCIATION.

The following has been received from the hon. secretary of the above association:—

"The members of the Queensland Bee-keepers' Association wish to tender to Mr. A. H. Benson, the Queensland Fruit Expert, their hearty thanks and appreciation for the valuable services rendered by him to the bee-keepers of Queensland at the Congress of Bee-keepers, recently held in England. In Mr. Benson the bee-keepers of this State have always had a sympathetic advocate, and, although not a practical bee-keeper, he has always recognised the importance of the bee in connection with the fruit industry."

Mr. J. M. Mitchell, Toowong, reports:—"There is a lively hum going on in my apiary that has been non-existent for a long time. The ironbarks are blooming freely, and the bees are bringing in a nice little flow of honey; while the queens are laying heavily. The brood frames are great cakes of brood, indicating rousing strong colonies of workers in a few weeks, capable of bringing in a large store quickly. The honey yield here was a total failure last season; and it is hoped—and present indications point to the probability—the trees will bloom in profusion this year, so that a good crop will be obtained."

Mr. G. Butler, Waterworks road, states:—"The bees are looking better than they have done for some time, and from present indications there will be an early flow. The grey gums and ironbarks are full of bud and bloom. The bees are working with a will, and the hopes of the bee-keeper are reviving."

The Editor will be glad to receive and publish any information concerning bee-culture in Queensland, from the Queensland Bee-keepers' Association.

The Horse.

CARE OF HORSES' HOOFS.

The most important point requiring attention in regard to the proper management of horses' feet is to see that the frog remains in a well-developed and healthy condition. Owing to the comparative obscurity of this organ of the foot, it receives but little or no intelligent attention from most horse-owners or their grooms. The only man who pays any attention to it, as a rule, is the blacksmith, and he is the very person who ought not to do so, as his attention is more often than not the reverse of intelligent, and does a lot of harm. Many farriers seem to think that the frog in the horse's foot exists for their special benefit, so that they may cut away parts of it. The fact that it is composed of horn, which is very easy to cut with the drawing knife, appears to be regarded by some of them as a good reason for mutilating it when shoeing a horse. The healthy frog in an unshod horse is always a prominent and well-developed, and it stands to reason that it must be quite wrong to reduce its size by paring away slices of the horn, because, if its presence in the foot were superfluous, we may be sure it would not be there. The first thing a horse-owner should do, if he wishes to care for his horses' feet in an intelligent manner, is to instruct his farrier not to mutilate the frogs, but to keep his hands off them. The orders in this respect should be absolutely peremptory, as it is difficult to induce some blacksmiths to leave the frog alone.

Next to the farrier's drawing knife, thrush is a great source of shrunken and small frogs. The prevention of this diseased condition of the foot is one of the main features in the practical management of the feet. The bedding must be kept clean and dry, as dirty litter, saturated with urine, generally induces thrush, if a horse stands on such for a continued period of time. The application of Stockholm tar to the cleft of the frog is a very good means of preventing the appearance of thrush, and this measure should be carried out once a week, while bi-weekly applications would be none too many.

It is especially necessary to keep the cleft of the frog free from particles of manure, because it is often a cause of thrush, unless continually dislodged. Manure has a decomposing action on horn, and more especially so in the case of the horn composing the outer frog, because the latter is of soft texture.

Though most attention is usually bestowed on the outside wall of the hoofs, this part of the foot really requires but little care, so far as the management of the feet is concerned. The principal point is to instruct the shoeing smiths not to apply the rasp to the outer wall, most farriers being just as fond of rasping the surface of the wall as paring the frog. If one examines the feet of horses that have not had the wall rasped at the forge, it will be seen that the surface of the wall is more or less shiny, and covered with a thin layer of gelatinous substance. This layer forms the natural protection of the horn of the wall against the softening influence of moisture, and it also to some extent prevents the horn from getting brittle. If the rasp is applied, the layer is destroyed, and the wall then readily suffers from the effects of too much moisture, or becomes brittle. The keeping intact of the gelatinous layer on the surface of the wall is certainly much more to the point than the application of some oily or fatty substance. Though it does not harm to apply the latter to the feet, the benefit accruing from it is problematically more imaginary than real.

Much moisture always has a softening effect on the horn of the hoofs, while dryness increases the hardness and toughness. Consequently the feet

of horses are generally softer during a spell of wet weather than when the weather is dry. Those having experience of riding unshod horses contend that unshod feet wear better in a dry season than in a wet one.

The comparative softness or toughness of horses' feet, however, depends not so much on external influences as upon the natural texture of the horny hoofs of each individual horse. Some horses have naturally much tougher feet than others, and if a horse has very soft or brittle hoofs these cannot be turned into tough ones by any artificial means.

IMPORTED STALLION KING EDWARD.

In August last there arrived in Brisbane from New Zealand the Clydesdale stallion King Edward, which has been purchased by the Department of Agriculture and Stock for use at the Warren State Farm, near Stanwell, in the Rockhampton district. The horse is rising three years old, having been foaled on 9th November, 1905. He is dark bay in colour, with two white hind legs and a white blaze down his face. As a yearling, King Edward took second prize at Invercargill show, and he was third the following year as a two-year-old. He is by the imported horse Bancor. Bancor's sire was King of Kyle (10200 C.S.B.), 1st dam Jess of Hawhill, by Columbia (6621), 2nd dam, bred by Mr. Caldwell, by Lyon Waterloo (2266); King of Kyle, by Prince of Kyle, by Prince of Wales. Bancor gained Selkirk and Galashiels premium as a three-year-old; as a two-year-old was placed at the Glasgow Stallion Show and the Highland, held at Aberdeen; won first prize at the show at Dumfriesshire, was first and champion at Tapanui a few weeks after landing in New Zealand, and was first and champion at Palmerston in 1906. He was sold to go to the North Island for nearly 900 guineas. King Edward's dam was Darling (780 N.Z.S.B.), her sire Macarthur (330 N.Z.S.B.), Macarthur's sire Macbride (2987 S.S.B.), Darling's dam Jean (774 N.Z.S.B.), her sire Extinguisher (174 N.Z.S.B.), g.g.g. dam Bess (775 N.Z.S.B.), her sire Darnley (104 N.Z.S.B.), his sire Young Banker.

RAISIN-MAKING.

All grapes for raisin-making should be dead ripe, as three or four days make a great difference in the amount of sugar in the grapes, and consequently in the quality of the raisins. All grapes do not ripen at the same time; therefore, the experienced grower will pick over the vineyard several times, each time picking only the ripened grapes. Each bunch must then be cleaned, every sunburnt berry and all foreign matter being removed. Then they are placed on trays, and the grapes are gradually dried by the sun. The best temperature is from 90 to 103 degrees in the shade. A much higher temperature will not injure very ripe grapes. When the heat is such that the raisins would cook and spoil, the trays should be stacked to protect the fruit until the heat has become less intense. After a few days' exposure to the sun in the vineyard, the grapes must be turned, as the grapes exposed to the sun will have dried, whilst those underneath are still green. The turning should not be done until the upper berries have quite dried, and the morning hours should be chosen for the work. The trays of dried fruit have next to be stacked. After remaining in the stack for some days, the raisins are placed in sweat boxes, 6 to 8 inches deep, for a couple of weeks, and are then ready for packing. It takes about 3 tons of grapes to make 1 ton of raisins.

Plate XXVII.



IMPORTED STALLION, KING EDWARD

Poultry.

FOWL CHOLERA.

The Board of Agriculture and Fisheries, London, has issued the following leaflet on the subject of fowl cholera:—

Fowl cholera is a highly infectious disease, which, though comparatively rare in this country, has caused serious loss to poultry-keepers on the Continent of Europe, in North America, and in South Africa. It frequently assumes an epidemic form, and in such cases often more than half the stock have succumbed. The disease affects not only fowls, as its name implies, but also geese, ducks, pigeons, pheasants, and some wild birds, such as sparrows and finches. Rabbits can be inoculated with the disease, but the larger domestic animals are not susceptible to the complaint.

The cause of the disease is a microbe, a minute ovoid bacillus, which is found in the blood, organs, and contents of the intestines of the infected animals. It passes into their droppings, and so is taken up in the food or drinking water of the healthy birds. Occasionally the disease is introduced into a flock by the purchase of infected birds, by infection picked up at poultry shows, or by birds being put into contaminated crates belonging to dealers or other persons. The microbe, however, is very easily destroyed by a weak solution of carbolic acid or sulphuric acid. It also dies after an exposure to sun and air.

Symptoms.—The period of incubation is very short, in some cases not more than eight hours, while it rarely exceeds sixteen. Fowls that have pecked the dead body of a comrade have been known to develop the disease in twenty-four hours. The disease takes two forms—the acute and the chronic. In the first case, the course of the illness is very rapid, and it frequently happens that no symptoms are observed, the bird dying before it is noticed as being ill. It may collapse in its walk, or fall from its perch to the ground and die, after giving a few flaps of its wings. But the symptoms when they are noticeable are as follows:—Affected birds become depressed, huddle themselves together, and hide their heads under their wings. The feathers become ruffled, the wings and tail droop, and the birds sway from side to side or stagger. The appetite is lessened, while thirst is greatly increased. There is a discharge from the eyes, nose, and beak, and the comb and wattles turn bluish-red. The most marked symptom, however, is diarrhoea. The evacuations are frequent and watery, being white or yellow at first and becoming greenish and foetid as the disease progresses, while the feathers round the hind parts become matted together. Except in the specially acute form mentioned above, the disease lasts from one to three days, though cases are on record where the illness was prolonged for a week. The birds usually die in a state of stupor or convulsions. The death rate in acute cases is very high, sometimes reaching even 80 or 90 per cent.

In the chronic form the more violent symptoms are not present, but the bird becomes thin and bloodless, and suffers from constant diarrhoea. Sometimes there is a breaking out on one or more of the joints, and the inflammation then set up naturally retards the recovery of the sick bird. Towards the end of an epidemic, however, milder cases occur, among which there are a greater number of recoveries. Birds which get well acquire a certain amount of immunity, and if they thrive are valuable for restocking purposes.

Appearance after Death.—In ordinary cases the only marks visible to the naked eye will be found in the intestinal tract, the contents of which are watery, frothy, and sometimes bloodstained. In the intestinal wall, and particularly in the mucous membrane, are formed patches of clotted blood and areas

of congestion ranging in colour from red to purple and black. The liver and spleen are usually enlarged, while in some cases the lungs are consolidated. In some places the mucous membrane may be destroyed, and in others patches of yellow exudate may be found. It must be remembered, however, that there are other poultry diseases with which it can easily be confused by the inexpert, and that in certain cases a microscopical examination is necessary.

Precautions.

1. All newly purchased birds should be isolated for a day, and the same course should be adopted in the case of birds returning from a poultry show.

2. Crates and packing material should always be disinfected, and care should be taken to secure an uncontaminated supply of food and drinking water.

3. When the disease appears, all infected birds should be strictly isolated, and healthy ones should be moved to fresh ground. The infected runs and pens should be sprayed with a disinfectant, such as a 5 per cent. solution of carbolic acid or 2 per cent. of commercial sulphuric acid in water.

Remedy.

There is no practical medical treatment which can be advised for diseased birds. A protective serum is in use on the Continent, but the small value of poultry renders the extensive use of this remedy too costly, except, perhaps, in the case of valuable pedigree birds.

AMOUNT OF SEEDS REQUIRED PER ACRE.

Amongst the many new settlers on the land in this State, there are probably some who have entered on the business of farming without much, if any, previous experience; and it may be of advantage to these to know how much seed to purchase for sowing or planting various crops.

Although there are certain crops which may practically be sown and raised all the year round in this favoured climate, yet the regular seasons for most crops are as clearly defined as they are in hotter, colder, or similar climates throughout the world. Allowance has, however, to be made in the times of sowing and the amount of seed needed, owing to the wide range of temperature, the difference in rainfall, and the variety of soils and their aspect in different parts of the State; but, as a general rule, the following quantities of various seeds required per acre will be found fairly correct:—

Barley, broadcast, 1 bushel to $1\frac{1}{2}$ bushel; drilled, $\frac{1}{2}$ -bushel. Beans (broad), drilled, $1\frac{1}{2}$ bushel; French Beans, $1\frac{1}{2}$ bushel. Horse beans, 2 bushels. Beet, drilled, 5 lb. Buck Wheat, broadcast, 1 bushel to 2 bushels. Cabbage (field), in seed beds, 2 lb. Carrots, drilled, 5 lb. to 7 lb. Clover, broadcast, 12 lb. to 20 lb. Grasses: Prairie, 1 bushel; Italian rye, 4 bushels; perennial rye, 2 bushels; couch, $\frac{1}{2}$ -bushel; permanent mixed pasture, 3 bushels; implee, 20 lb. Kohl-rabi, drilled, $2\frac{1}{2}$ lb. Lucerne, broadcast, 20 lb.; drilled, 10 lb. Maize, broadcast for fodder, 3 bushels; drilled for grain, $\frac{1}{2}$ -bushel. Mangolds, drilled, 5 lb. to 6 lb. Millet, broadcast, 1 bushel. Oats, broadcast, 2 bushels. Onions, broadcast, 5 lb.; drilled for setts, 20 lb. Panicum, broadcast, 20 lb. Parsnips, drilled, 8 lb. to 10 lb. Peas, broadcast, $2\frac{1}{2}$ bushels; drilled, 2 bushels. Potatoes, cut setts, 14 cwt.; whole, 10 cwt. Rye for grain, broadcast, $\frac{3}{4}$ -bushel. Sorghum for grain, in drills, 10 lb.; broadcast for green fodder or ensilage, 20 lb. Swedes, 3 lb. to 4 lb. Turnips, globe and yellow, drilled, 2 lb. Vetches, broadcast, 3 bushels. Wheat, broadcast, 1 bushel to $1\frac{1}{2}$ bushel; drilled, $\frac{1}{4}$ -bushel. Paddy (rice), 30 lb. to 40 lb. Cowpeas, 8 lb. Jerusalem artichokes, 3 cwt. to 4 cwt. Paspalum, 2 bushels to 3 bushels. (Paspalum seed weighs 140 lb. per cornsack). A good stand of Paspalum will result from sowing from 10 lb. to 15 lb. of seed per acre.

The Orchard.

THE BREEDING-PLACE OF THE CODLIN MOTH.

A writer in the "Fruit World" points out that apple-growers have been on the wrong scent for the codlin moth when they look for the worms in the orchard. He says:—

LOOK TO YOUR FRUIT HOUSES.

If one were to tell the apple-growers of California that they are in the habit of providing nice, comfortable breeding-places for their old enemy, the codlin moth, where it can pass the winter in safety, secure from the attacks of all its enemies, and be ready to come forth in the spring to commence anew the ravages upon their orchards, the statement would probably be received with incredulity or with a pitying smile for the ignorance of the adviser. And yet the statement is true.

For many years the orchardists of California have been spraying their apple-trees several times a year, in the endeavour to rid themselves of this pest (says the "Californian Fruitgrower"). Tree by tree they have gone over their orchards carefully, trying, at heavy expense, to lessen the numbers of the codlin moth. And what has been the result? Are not the insects practically as numerous now as they have been at any time? Some rare years it may seem as if success had to some extent crowned the efforts of the fruit-grower; the pest appears on the point of being defeated. But the next year it is back in full force, as bad as ever.

In spite of many years of experience, the apple-growers of California still have the idea that the codlin moth winters in the orchard. It does not altogether. Let any grower go into his orchard at this time of year, and see how many codlin moth worms he can find in the course of a whole day's search. If he finds ten, he will be doing well. The statement seems incredible, but it is easy to test the truth of it.

A little while ago two men interested in the subject visited one of the largest apple orchards in the State, an old orchard which is usually overrun with codlin moth. They devoted the entire day to a search for codlin moth. They twisted old bark off the trees, dug into likely-looking places, even tore down some old trees, and examined every part of them carefully. During the entire day they found six worms.

In this same orchard last year were liberated a colony of the new parasites which George Compere brought from Spain. Several months later these parasites were flying about the orchard by hundreds. Last week there was not one to be found. They had been starved out.

But where, then, is the codlin moth? Has it been destroyed?

These two men went into the packing-house and began an investigation of conditions there. Few signs of the moth were to be seen. Finally, someone suggested going into the cellar. There the solution of the question was found. There was a 3-inch interval between the edge of the flooring and side walls. On the under side of the flooring, extending back for several feet, was a solid mass of codlin moth chrysalids—thousands of them. The worms had dropped from the tables to the floor, and hurried away from the light to the edge of the floor, where they had crept down to the under side and pupated.

Here, then, was the supply of codlin moth for the coming season. When the time comes, they will emerge from the chrysalids as moths, and hasten away to the orchard to become the parents of the countless hordes of codlin moth worms which will attack the apple crop—and for which the grower will spray several times during the season.

This is not an exceptional case. It is merely an example of conditions which may be found in practically every apple packing-house. The worms at this time of the year are not so much in the orchard as in the packing-houses. The few that winter in the trees are a negligible quantity. Their natural enemies will take care of them—beetles, woodpeckers, &c. Those in the packing-houses are the ones that need particular attention.

At a minimum expenditure of labour and money, the apple-grower can practically destroy all the codlin moth, and—provided his neighbours do the same—render himself secure from their attacks during the coming season. He has the moths coralled in one place. All he has to do is to destroy them.

And the method is not difficult. Most of the packing-houses are built tightly enough, so that they can be closed up and fumigated. Close the doors and windows, and stop up any cracks that may be found. In the case of the smaller buildings, if necessary, spread a tent or other covering over them. Then fumigate thoroughly with cyanide. That will entirely destroy all the moths, except such as have bored their way into the boxes, &c. Boil the boxes. This is not a difficult operation. Practically all packing-houses have vats for mixing sprays. Boil the boxes in these.

QUEENSLAND FRUITS IN LONDON.

A report has been received by the Under Secretary for Agriculture and Stock, from Mr. A. H. Benson, Fruit Expert to the Department, on the present condition and possibilities of the London fruit market as it concerns Queensland fruits. He writes—

“As we can get Queensland citrus fruit into the English market now, I have been making inquiries as to the price likely to be obtained, the class of fruit required, how it is to be packed, and any other matters of interest to our growers. In the first place, there is a market now for first-class fruit, and, as the heavy supplies of European and home-grown plums fall off, the demand will improve. The best months for our citrus fruits here are August and September, though there is a good market for high-class navels and possibly high-class mandarins during June and July as well. Only first-class fruit is wanted. It must be clean and bright, with fine thin skins (no rough-skinned fruit will pay to send, and no russy fruit, ‘Maori’). The best fruit on the market now is oranges from Jamaica. They are seedlings, round, of about 2 inches in diameter, light yellow colour, and thin skins, and are very like the fruit grown at Cardwell, Bowen, and Port Douglas. The skins are finer than the bulk of the Maryborough and Blackall Range fruit, and very much finer than those of the Lockyer and Downs. Western grown fruit, such as the navels produced at Barealdine, will fetch fancy prices here. Good seedling fruit such as I have described will fetch now about 14s. per bushel case containing about 112 oranges. The trade is very emphatic as to our sending nothing but the very best fruit, and from what I can see of the market I quite agree with them. No fruit must be exported from Queensland here unless it is up to standard quality, as the sending home of inferior goods will simply ruin this market. The whole world is catering for this country, and the buyers want the best that the world can produce. It is no good for our growers to ignore this fact, and, should they send other than the best, they will, in the majority of cases, be badly left.

“As to packing, the fruit must be wrapped, glazed paper or thin waxed paper being used. It must be thoroughly sweated before it is packed, and it must be packed so firmly that it will not roll about in the case, but not so firmly as to crush the fruit all out of shape. The size or shape of the case is immaterial, the fine appearance and quality of the fruit determining its value.

Mandarins from South Africa are on the market, and are selling at a very satisfactory price. They are of the scarlet type, of medium size and good colour, and have fairly tight skins. They are packed in fancy trays holding one layer of fruit, and five of these trays are bound together with thin hoop iron. There are no cleats between the trays, but these would be necessary in sending from Queensland. Each fruit is wrapped in fine paper, and each wrapper carries the brand of the shipper. This is advisable, as stencilled wrappers are better than plain. Good Emperor Scarlet or Beauty of Glen Retreat mandarins packed in this manner should carry all right and sell well. This information is practically the same that I have given our growers ever since I have been in the service of the Queensland Government, and simply bears out the soundness of the advice I have given. The method of packing the mandarins, which is, by the way, quite new here, is what I have recommended over and over again. As to pineapples, the market is bare now, and only medium fruit is worth 3s. 6d. each. Bananas are in good supply, and the price is lower owing to the quantity of summer fruit in the market. Cavendish bananas come from the Canary Islands in the bunch, each bunch being packed in a separate crate. Great care is taken in packing. The bunch has first a thin layer of cotton wool round it. It is then wrapped in paper, and outside the paper is a thick layer of straw or dry banana leaves. The fruit arrives here in the green state, and is ripened by artificial heat. These bananas sell usually at 1s. a dozen, but can be bought now eighteen for 1s. They are of fair flavour and medium size. They are, as a rule, better filled than the North Queensland fruit, but are not equal to the best Buderim Mountain. The bulk of the cheaper bananas comes from Jamaica. They are of the Gross St. Michael variety that sells so well in Sydney. The fruit is of large size, showy, and many of the bunches are very large. Though a much larger and more showy fruit than the cavendish, it is not equal to it in flavour, and as a result only fetches about half as much as the latter, thus reversing the market in Sydney, where this inferior kind fetches the highest price on account of its showy appearance.

"Grapes are plentiful, both hothouse and early ripening grapes from Spain. The latter are packed in cork dust, and arrive in good order. Pears are coming in freely from France, and both Bartlets and Beune Hardy are to hand from California. Plums, both local and European, are in large quantities, and extra fine. Kelsey Japan, Washington, and Yellow Egg, from California, are shown. Melons, both yellow and cantaloupe, are to hand in quantity. The yellow is a Spanish fruit that keeps and carries well. It is sold at a cheap rate, and, though not of the best flavour, it may possibly pay to grow in Queensland for shipping South, as it is the best keeper and shipper I have seen. I will get seed for testing in our State. The cantaloupes are of large size and fair quality. They are a rather different type from what we grow, and I will get seed. They come from Southern Europe, and are carefully packed in large crates. Wood wool is used for packing. Netted or rock melons are hot-house grown, and fetch high prices. Tomatoes are both good and plentiful. They are sold in peck baskets holding 12 lb. net, and are fetching now about 2s. 3d. per basket. They retail at 4d. per lb. The type of fruit that sells best is a small to medium tomato with a dark-red skin, smooth, round, firm flesh, and a good shipper. Cucumbers are plentiful, as well as vegetables of all kinds. One thing that strikes me is the great improvement in the packing of fruit and vegetables that has taken place during recent years, the object being to get all kinds on to the market in the pink of condition. Baskets, both peck, half bushel, and bushel, are still used to a very large extent, but cases of all sorts, crates, &c., are now much more commonly used than they were a few years since.

"In regard to apples, the local fruit is coming in—some very bad with fusicladium, and some excellent Canadian apples of last year's crop are still on

sale. Newtown pippins from Oregon that have been kept in cool storage are also still in splendid order, but in my opinion it is doubtful if it will pay to keep them so long, as they cannot compete with the new season's fruit, not coming in in quantity and rapidly improving in quality. I hope to go much further into fruit matters, and to look up our markets for canned goods, &c., and trust that I will be able to get hold of information that will be of real value to our State.

"With respect to other matters, I have made numerous inquiries regarding fibre plants and fibre-extracting machinery. I have also found out what I can regarding oil and oil-yielding plants, and have gone carefully into the question of date culture. I have met the Tunisian representative at the Franco-British Exhibition, and have arranged to exchange products with him, as I can obtain some of the best dates in the world from the Oasis to the south of Tunis, and hope to get suckers off bearing palms from there. Tunis grows good Algerian oats, fair barleys of the Cape type, a large-seeded linseed, and some good wheats of the macaroni type."

Times of Sunrise and Sunset at Brisbane, 1908.

| DATE. | SEPTEMBER. | | OCTOBER. | | NOVEMBER. | | DECEMBER. | | PHASES OF THE MOON.
H. M. | |
|-------|------------|-------|----------|-------|-----------|-------|-----------|-------|------------------------------|------------|
| | Rises. | Sets. | Rises. | Sets. | Rises. | Sets. | Rises. | Sets. | | |
| 1 | 6:3 | 5:34 | 5:29 | 5:47 | 4:58 | 6:5 | 4:49 | 6:23 | 4 Sept. ☾ First Quarter | 6 51 a.m. |
| 2 | 6:2 | 5:34 | 5:28 | 5:48 | 4:57 | 6:6 | 4:46 | 6:29 | 10 " ○ Full Moon | 10 23 p.m. |
| 3 | 6:1 | 5:35 | 5:27 | 5:48 | 4:57 | 6:7 | 4:46 | 6:29 | 17 " ☽ Last Quarter | 8 33 " |
| 4 | 5:59 | 5:35 | 5:25 | 5:49 | 4:56 | 6:8 | 4:46 | 6:30 | 26 " ● New Moon | 0 59 a.m. |
| 5 | 5:58 | 5:35 | 5:24 | 5:49 | 4:55 | 6:8 | 4:46 | 6:31 | | |
| 6 | 5:57 | 5:36 | 5:23 | 5:50 | 4:55 | 6:9 | 4:46 | 6:32 | | |
| 7 | 5:56 | 5:36 | 5:22 | 5:50 | 4:54 | 6:10 | 4:46 | 6:32 | | |
| 8 | 5:55 | 5:37 | 5:21 | 5:51 | 4:53 | 6:10 | 4:46 | 6:33 | 3 Oct. ☾ First Quarter | 4 14 p.m. |
| 9 | 5:54 | 5:37 | 5:20 | 5:51 | 4:53 | 6:11 | 4:46 | 6:34 | 10 " ○ Full Moon | 7 3 a.m. |
| 10 | 5:53 | 5:38 | 5:19 | 5:52 | 4:52 | 6:12 | 4:47 | 6:35 | 17 " ☽ Last Quarter | 1 35 p.m. |
| 11 | 5:52 | 5:38 | 5:18 | 5:52 | 4:52 | 6:13 | 4:47 | 6:35 | 25 " ● New Moon | 4 47 " |
| 12 | 5:51 | 5:39 | 5:17 | 5:53 | 4:51 | 6:13 | 4:47 | 6:36 | | |
| 13 | 5:49 | 5:39 | 5:16 | 5:54 | 4:51 | 6:14 | 4:47 | 6:36 | | |
| 14 | 5:48 | 5:39 | 5:15 | 5:54 | 4:50 | 6:15 | 4:48 | 6:37 | | |
| 15 | 5:47 | 5:40 | 5:13 | 5:55 | 4:50 | 6:16 | 4:48 | 6:38 | 2 Nov. ☾ First Quarter | 0 16 a.m. |
| 16 | 5:46 | 5:40 | 5:12 | 5:55 | 4:49 | 6:16 | 4:48 | 6:38 | 8 " ○ Full Moon | 5 58 p.m. |
| 17 | 5:45 | 5:41 | 5:11 | 5:56 | 4:48 | 6:17 | 4:49 | 6:39 | 16 " ☽ Last Quarter | 9 41 a.m. |
| 18 | 5:43 | 5:41 | 5:10 | 5:56 | 4:48 | 6:18 | 4:49 | 6:40 | 24 " ● New Moon | 7 53 " |
| 19 | 5:42 | 5:42 | 5:9 | 5:57 | 4:48 | 6:19 | 4:49 | 6:40 | | |
| 20 | 5:41 | 5:42 | 5:9 | 5:58 | 4:48 | 6:20 | 4:50 | 6:41 | | |
| 21 | 5:40 | 5:43 | 5:8 | 5:58 | 4:47 | 6:20 | 4:50 | 6:41 | | |
| 22 | 5:39 | 5:43 | 5:7 | 5:59 | 4:47 | 6:21 | 4:51 | 6:42 | 1 Dec. ☾ First Quarter | 7 44 a.m. |
| 23 | 5:38 | 5:44 | 5:6 | 5:59 | 4:47 | 6:22 | 4:51 | 6:42 | 8 " ○ Full Moon | 7 44 " |
| 24 | 5:37 | 5:44 | 5:5 | 6:0 | 4:47 | 6:23 | 4:52 | 6:43 | 16 " ☽ Last Quarter | 7 12 " |
| 25 | 5:35 | 5:44 | 5:4 | 6:1 | 4:46 | 6:23 | 4:53 | 6:43 | 23 " ● New Moon | 9 50 p.m. |
| 26 | 5:34 | 5:45 | 5:3 | 6:1 | 4:46 | 6:24 | 4:53 | 6:44 | 30 " ☾ First Quarter | 3 40 " |
| 27 | 5:33 | 5:45 | 5:2 | 6:2 | 4:46 | 6:25 | 4:54 | 6:44 | | |
| 28 | 5:32 | 5:46 | 5:1 | 6:3 | 4:46 | 6:26 | 4:54 | 6:44 | | |
| 29 | 5:31 | 5:46 | 5:1 | 6:3 | 4:46 | 6:26 | 4:55 | 6:45 | | |
| 30 | 5:30 | 5:47 | 5:0 | 6:4 | 4:46 | 6:27 | 4:55 | 6:45 | | |
| 31 | ... | ... | 4:59 | 6:5 | ... | ... | 4:56 | 6:46 | | |

Horticulture

FLOWER GARDENING, No. 9.

By THE EDITOR.

PLANTS SUITABLE FOR OUT AND IN DOOR CULTURE.

CALCEOLARIA.

These highly ornamental plants are general favourites for the decoration of the bush or green house. The seed should be sown in the autumn. They require rich, light, fibrous soil and plenty of pot room. They are tender plants, and must be carefully raised in a seed box or pot.

HYBRID CALCEOLARIAS.

The cultivation of hybrid calceolarias is not difficult, but it is absolutely necessary for the production of good plants to keep them growing without the least check from the time the seedlings are pricked off until they have outlived their usefulness. The seed should be sown in shallow pans filled with soil composed of leaf mould, sand, and fibrous turf; the top portion of the soil should be run through a very fine sieve. Before filling, the pans should be provided with ample drainage. As the seed is very fine, no soil is necessary to cover it, but it will be well to water the surface of the soil in the pans before sowing the seed, which may be scattered evenly on the damp surface after the water has drained away sufficiently. Cover the seed pan with glass, and it should be kept covered and the covering removed only when the soil needs watering, which should be done by dipping in a pail or tank of water, so that there will be no danger of disturbing the seed in course of germination. When the little plants are easily discernible, the glass may be removed from the pans, and when the seedlings can be easily handled they should be pricked off into flats, about $1\frac{1}{2}$ inch between the plants. They may remain in the flats until they show signs of crowding, when they will require to be potted into the smallest sized pots, using less sand and leaf mould and more fibrous loam, with the addition of a reasonable portion of well-rotted cow manure, and continuing to increase the sustaining nature of the potting material with each successive shift. Calceolarias will not at any stage of their growth take kindly to the full sunlight; but a thick shading is not what they want. Rather place them, if possible, in a situation where they can have adequate light, such as a northern exposure of a house or frame affords—in fact, a cold frame is just the place for them during a great part of their growing period. A cool temperature is essential to their proper development, just as careful watering is necessary to bring them to perfection. They can be flowered in 6-inch pots, but 7-inch pots will give better results. Liquid manure, when they are beginning to show flower, helps them considerably. When the plants are fully grown, they should be placed so that the leaves of one do not touch those of another. Greenfly, if allowed to attack them, will soon ruin them; the safest preventive is the distribution of tobacco stems liberally around the pots.

CINERARIA.

Cinerarias are generally raised from seed sown from September to December for autumn flowering, and in April and May for spring flowering. In common with the calceolaria and the Chinese primrose, they are best treated as annuals. The seed should be sown in shallow pans containing a compost of sifted leaf-mould, loam, and sand, and kept shaded. When the seedlings are

large enough, prick them out into 3-inch pots, and again into blooming pots as soon as the smaller pots are well filled with roots. Use light soil mixed well with old cow manure, a little sand, and old vegetable mould made from decayed leaves. Transfer them to the bush-house as soon as established in the blooming pots. Strict attention must be paid to watering, and weak applications of liquid manure are beneficial during the flowering period.

An authority on flower gardening writes on the subject of these plants to the "Australian Gardener," and, although it repeats some of my remarks, I quote him as bearing them out:—"Cinerarias, when well grown, are well worth the trouble necessary for their successful cultivation, but, like many other things, if they are in any way neglected, they are almost useless, and seldom pay for the labour expended on them. The most essential point in the culture of cinerarias is to keep them growing uninterruptedly from start to finish, never to let them get potbound until they are in their last or flowering pots. Equally important, perhaps, is the keeping of them in as cool a temperature as possible when growing on, and in order to do this the plants when in pots should be grown in a cold frame on a bed of ashes, with the sashes sloping to the north. The seed should be sown in shallow pans over a filling of sand, loam, and leaf mould in equal parts, pressed firmly. The seed should be scattered thinly over the surface, and covered lightly with sand, and then watered carefully with a fine rose. Place the pans in a cool place immediately, and attend carefully to watering until the seedlings are above ground and fit to handle, when they may be potted at once into the smallest sized pots obtainable, using soil for the first potting of the same materials and proportions as for the seed. But, in subsequent potting, soil composed of two-thirds good fibrous loam and one-third of sand, with a good sprinkling of sand added, will suit them better. For the last potting it will be very beneficial if only a little leaf mould is put into the compost, and in its place is afforded well-rotted cow manure without sand. When there is danger of allowing the plants to remain longer in frames, they should be brought into the greenhouse, still kept cool but somewhat moist with an occasional aid to the circulation of air by a little fire heat, especially in very damp weather. The temperature at night should not exceed 48 degrees, allowing a rise of about 10 degrees with sunlight. When the flower buds appear, applications of liquid manure will help the plants; but it should be rather weak, or else use the precaution of watering immediately after with clear water. Cinerarias are subject to green fly, but the plants will stand fumigating mildly. Tobacco stems scattered among the pots will act as a preventive also."

SOME GOOD CALCEOLARIAS.

Dalkeith Park Strain.—Flowers beautifully spotted and tigned, of the most brilliant colours.

Hybrida grandiflora; *Hybrida striata*, and many tigned and self-coloured.

CYCLAMEN.

This is another beautiful member of the tribe of tuberous greenhouse plants produced from seed. They may be sown from December to March, are perennials, and present a most charming appearance during winter and spring. They remain a very long time in bloom. The seed should be sown in a soil composed of loam, peat, and a small quantity of fine cowdung and sand. Sow thinly, and cover lightly. Water with a fine rose, and do not let the soil become dry. When the small bulbs are formed, pot off into small pots, taking all the fibrous roots with the plants. In potting, bury the bulb, just below the surface of the soil, up to the crown. They require shade. When the leaves show signs of dying, give less water for a time, but do not let them get quite dry. As soon as they begin to show new growth, re-pot into fresh soil.

SOME GOOD CYCLAMENS.

Cyclamen giganteum (Margaret).—White, with lilac eye. *C. Persicum giganteum* (Snowflake).—Very large, dazzling, satiny white; petals large, habit compact, growth vigorous. *C. Persicum* (Papilio).—This is a very charming variety, perfectly distinct from all others. *C. Bush Hill* (Pioneer).—A beautiful feathered and crested variety. *C. Persicum giganteum sanguineum*.—One of the finest varieties. The flowers are of a deep, rich shade of blood-red. *C. Rococo*.—This variety has finely-marked leaves and an abundance of flowers on long, upright stalks. The large, flat, round flowers, sometimes 4 inches across, contain five or six petals, which are finely imbricated and undulated. The colours are very pretty, and include pure white, white with purple eye, dark-red, rose, &c.

CALADIUMS.

Caladiums are, as all horticulturists know, grown only for their beautiful foliage. They are tuberous plants, which prefer a high temperature while in growth, and require much water. The latter, in cool climates, should be given warm; but in Queensland the water in summer is quite warm enough without any artificial aid to increase its temperature.

Although a greenhouse plant, the caladium will thrive in the warm coast districts in sheltered situations in the open, and generally in the bush-house. Preferably, they should be grown in pots. The pots containing the tubers should be taken in succession, in the spring, and placed in heat. Then, when the tubers have started to grow, they must be taken out, and re-potted in fresh soil, which must be light and rich, composed of loam, peat, leaf mould, rotten manure, and sand. They must be shaded, but kept in a warm atmosphere to ensure a sturdy growth. In summer, when the leaves are fully developed, they may be placed in the bush or green house. As the leaves begin to die off, the water supply must be stinted, and the tubers be kept nearly dry, but in a moderate temperature during the winter. Plant from September to November.

SOME GOOD CALADIUMS.

Anna de Condeixa. Argyrites; pale-green, with white spots. Belleymeis; white variegated leaves. Beethoven; white ground, veined green. Chantini; reddish ground, spotted white. Dr. Lindley; crimson centre, the green ground marked with rose blotches. Felicien David; carmine, surrounded with white and veined red on green ground. La Perle du Bresil; white, delicately tinted with rose; midrib and veins dark green. Leplay; leaves marked white, and beautifully veined rosy violet. Louise Duplessis; red veins, white ground. Madame Heine; silvery white, stained and edged with pale green. Madame Marjolin Scheffer; white foliage, charmingly veined and netted rosy lake. Murillo; pale-green ground, crimson centre, midribs white, green edge. Pictum; green, blotched and spotted white. Pœcile; red and white spots. Prince Albert Edward; dark emerald green, rich crimson midrib, white spots. Reine Victoria; green veins and margins, spotted white and rich crimson. Ville de Hamburg; rose-coloured leaves, red veins. Wighti; green, spotted red and white.

COLEUS.

As a foliage plant, the coleus is very ornamental, the exquisite and varied markings and variegations of the leaves making them highly interesting. They may be grown from seed or propagated by cuttings, and grow very rapidly. In our Queensland climate, cuttings strike freely in the open, and the cuttings may be put in where the plants are intended to remain. In districts where no frosts occur, the plants will, with care, continue to grow all the year round. They must be grown freely, in good soil, with plenty of moisture, light, and air. It may be treated as a pot plant, and grown in a conservatory or bush-house. In this State it makes a magnificent garden plant, where it frequently

attains a height of 4 feet. The best plan is to put cuttings in in autumn, keep them in a moderate temperature during the winter, and pot them or plant them out in the early spring. The Mammoth Rainbow is a specially fine variety.

CROCUS.

The crocus is one of the earliest of spring flowers. It demands a light soil, and the bulbs should be planted tolerably deep in the ground. The colours of the flowers are white, blue, yellow-striped, and purple. They make very nice edging plants, and, in this State, may be planted at almost any time of the year. They increase so rapidly that they require to be taken up every year and divided.

ANNUALS—(continued).

Before continuing the directions for the cultivation of annuals, I wish to point out that there are many half-hardy and tender annuals which, in the Southern States, require the aid of artificial heat, when sown during autumn or early spring, until they are strong enough to be planted out in the open. Many of these require no such aid in this State. For instance, Aster, Balsam, Lobelia, Zinnia, Portulacca, &c., may be safely sown, in suitable soil, in sheltered situations in the garden, in the spring, in the same way as the hardier annuals, such as Candytuft, Calliopsis, Dianthus, Chrysanthemum, Marigold, Mignonette, Larkspur, Phlox, Stock, Gaillardia, Nasturtium, &c. Although, however, the climate of Queensland is admirably adapted to the growth of flowers, amateurs are often at a loss as to the method of dealing with plants, so as to ensure the best possible results, and it is with a view to assisting them in this matter that the following remarks are made. It will be quite understood that it is impossible to give anything like exact directions for the cultivation of every kind of garden flower, but I have endeavoured to cull from many horticultural works, and more particularly from the publications of Australian professional and amateur gardeners and nurserymen of known repute, such simple, practical rules as are generally applicable, and such as will put growers in a fair way of success.

SOIL.—In the first place the nature of the soil claims attention. For the larger class of seeds, such as Nasturtium, Sweet Peas, &c., ordinary garden mould is suitable; but to sow the finer seeds it is necessary to have the soil of fine consistency, freely mixed with sand, and, if possible, leaf mould or well-rotted turf. The surface should be raked very smooth, and, if dry, watered gently about an hour before sowing the seed.

SOWING.—When considerable breadth is require, it is desirable to sow all hardy seeds where they are intended to flower; but, in the case of tender sorts, and when only a small number of plants are wanted, it is always best to sow in specially prepared beds or boxes, and then transplant. When the seeds are sown, it is advisable to press the soil lightly down, so as to hold them in position, while the radicle, or first root, is pushed down into the ground. We would impress on amateurs the benefit of sowing thinly; thick sowing causes the young seedlings to become "drawn," and has the effect of making "leggy" and unhealthy plants.

For the cultivation of the finer strains of seeds, such as Primulas, Calceolarias, Cinerarias, &c., some slight extra care is necessary; the trouble will be amply repaid, however, by the quality of the produce. They should be sown in seed pans or pretty large pots, great attention being paid to the drainage. The soil must be made very fine on the top, and the seed thinly scattered. Do not cover the seeds with earth; but lay a piece of obscured glass, or, better still, a sheet of brown paper, over the pot; place in a cool greenhouse, near the glass, and when the plants appear attend very carefully to watering; pot out the young plants into "thumb" pots when strong enough to handle, and give a

moderately cool, even temperature, protecting them thoroughly from cold winds and sudden changes.

DEPTH TO SOW.—As to the proper depth to sow seeds, there can be no hard-and-fast line drawn, but it may be laid down as a rule that no flower seeds should be put more than $\frac{1}{2}$ -inch below the surface; indeed, most varieties will be sufficiently covered at a depth of $\frac{1}{4}$ -inch, only the very large sorts requiring more.

Fine seed, such as Lobelia, Mimulus, &c., require no covering beyond what is given by pressing the soil down after sowing.

TIME TO SOW.—Hardy annuals are those which may be sown in the open borders during autumn or spring, requiring no protection.

Half-hardy and tender annuals are those which, if sown during autumn or early spring, require the aid of artificial heat, frame, or bell glass; and also require protection until they are sufficiently strong to bear transplanting into the open border. They may also be sown in the open ground late in spring, when the weather is sufficiently warm to be suitable to their constitution.

Half-hardy Biennials and Perennials.—These are best sown during the months of September to December.

Hardy Biennials and Perennials may be sown either autumn or spring.

TRANSPLANTING may be done in most cases when the young plants have made the second pair of leaves, but with half-hardy and tender varieties it is advisable to prick them out at this stage into "thumb" pots—three to five plants in a pot—and keep them well sheltered and gently watered until thoroughly established before finally transplanting them.

WATERING.—Careful and judicious watering is a great point in the cultivation of flowers. Of course no rule can be laid down, but it is necessary to keep the surface always moist, especially before the seeds have vegetated. The neglect of half an hour may ensure a complete failure in the case of nearly all the small seeds. Always use a fine rose watering can, so as to prevent beating down or washing away the young plants. When the plants are flowering, they will require frequent watering if the weather be dry. An occasional watering with weak liquid manure will tend to prolong their flowering, and increase the size and brilliancy of the flowers; where the soil is poor, liquid manure watering is indispensable.

DRYING APPLES.

The apples are first peeled and cored by machines. Then they are cut into slices or rings. In order to prevent discoloration during evaporation, the slices are placed in a bleaching chamber, and there subjected to the fumes of sulphur. From this chamber the bleached slices are laid on wire trays in the drying chamber of the evaporator. In from three to five hours, the whole of the moisture is evaporated, and the dried fruit is packed in boxes holding from 25 lb. to 50 lb.

SISAL HEMP CULTIVATION PROJECT IN BRITISH GUIANA.

The news will be received with satisfaction in Georgetown that on the 21st ultimo a wire was received from New York, stating that all the necessary capital had been subscribed for putting into execution the project to extensively cultivate sisal hemp in the tract of country, comprising some 7,000 acres, in the vicinity of Bartica, granted by the Government for this purpose. Mr. Viton stated to a representative that something like 50,000 dollars will be put into circulation in the colony in putting the land into cultivation.—"Demerara Chronicle," 1st May.

Sericulture.

SILKWORMS AND HOW TO REAR THEM, No. 2.

FOOD.

The intending sericulturist, having decided on going in for the business, must at once set about planting his mulberry trees. The varieties recommended are—*Morus indica* and *Morus multicaulis*. The former, being cultivated as a shrub, gives several crops of leaves in the season, and has to be kept pruned to a height of 4 feet 6 inches. It is easily grown from cuttings, which will strike at any season of the year, and will grow anywhere except in a swamp. *Morus multicaulis*, known as the Manila variety, comes into bearing very early, and hence is useful for the early hatched worms. The variety of mulberry, however, need not be considered, one being just as suitable for the purpose as another.

The mulberry cuttings should be 6 inches in length, and planted in a bed 4 or 5 inches apart, leaving about 1 inch out of the ground. When they have struck, they should be transplanted to the land prepared for them, and planted 4 feet apart each way. This method of planting facilitates gathering the leaves, pruning, and cleaning. By the end of the season, the bushes should be pruned, cutting well into the head. The object being to prune for leaf, all useless twigs should be cut out, and a broad, flat top preserved; allow lateral shoots to grow. The object in pruning should be to induce an outward growth, so as to get a larger picking surface.

The gathering of the leaves is best done by cutting the plants right down to the ground—cutting, of course, only the quantity actually required—daily. The plant soon sprouts again, when the cutting is repeated, and so on. This system need not prevent those who have large standard trees from using them, but the shrub system is to be preferred where very large quantities of food have to be provided.

While on the subject of food, it may be mentioned that the Osage Orange (*Maclura aurantiaca*) is extensively used in America for feeding the silkworm, and is said to give better results than the mulberry, the silk produced being of much better quality and, in some instances, a less number of cocoons were required to produce a pound of silk from worms fed on this than from those fed on the mulberry. Lettuce leaves can also be used if the mulberry is a bit backward, but, of course, this is only a temporary expedient.

An accidental discovery was made by a lady sericulturist in America. Having an early batch of worms and no feed being available, she tried the leaves of the Ramie Plant (*Bahmeria nivea*). The worms ate the leaves greedily, the result being larger cocoons and finer silk. This accidental discovery may be the means of providing food for silkworms at seasons when mulberry leaves are not available, and, indeed, may be the means of an extra brood or two being raised during the year and of superior quality. The ramie plant being of the same natural order as the mulberry—namely, *Utricaceae*—its being a suitable food is not to be wondered at. The ramie plant thrives luxuriantly in Queensland.

SILK REELING.

From the cocoon, the silk is, by different processes, transformed into spun or reeled silk.

Spun silk is made from pierced cocoons (that is, cocoons from which the moth has escaped) and silk waste, and serves in the manufacture of inferior classes of tissues.

The method of manufacture consists in cleaning and macerating the raw material, after which it is corded and made into thread, somewhat after the manner of cotton.

Plate XXVIII.

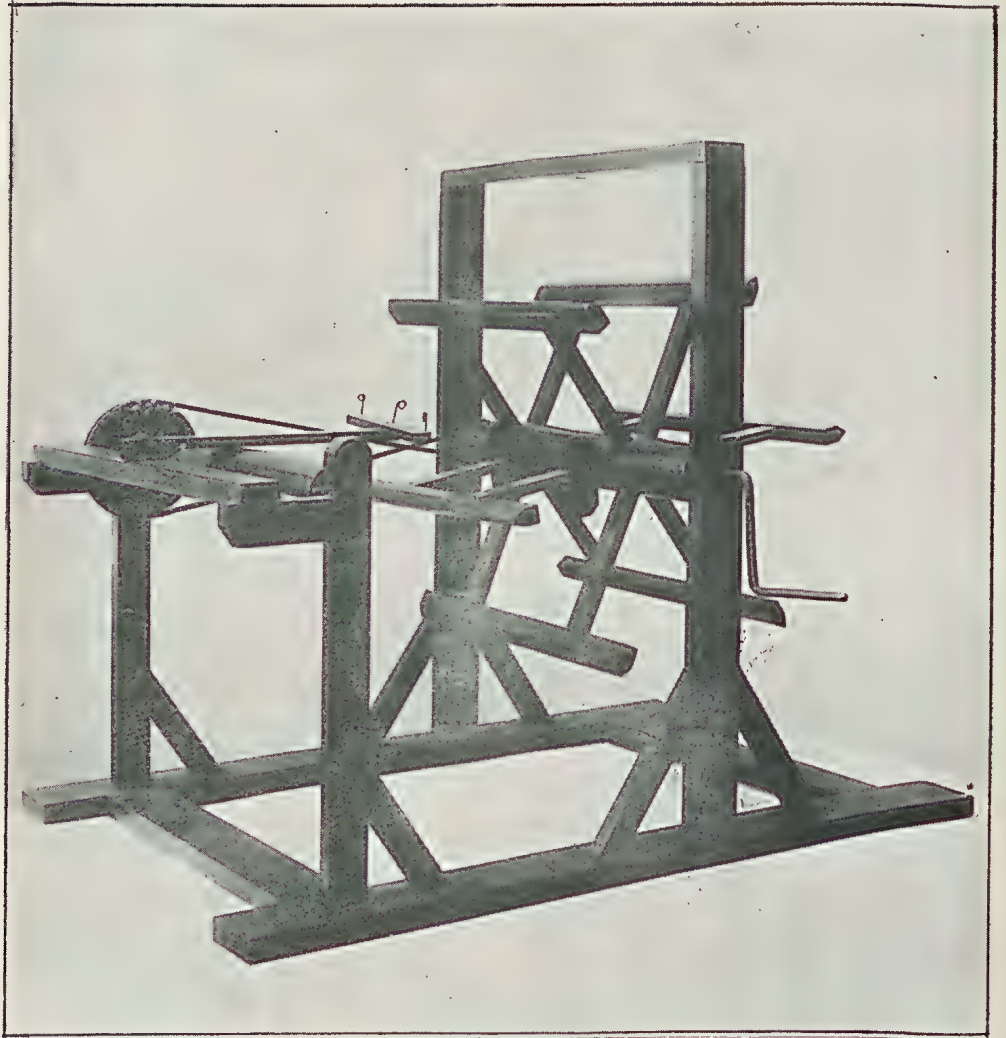

SILK-REELING APPARATUS,

The process of producing reeled silk, which will be hereafter described, consists, in general, in softening the gluten of the cocoons in hot water, and then taking the ends of the constituent threads of several of them together, and winding these threads from the cocoons upon a reel.

Thrown silk, the next process, is made from either spun or reeled silk. It is classified as "organzine" and "tram." Tram consists of two or three threads of reeled or spun silk twisted together at about 95 to 100 turns per running yard. It is used in making the warp in weaving. Organzine, used in the woof, is produced by twisting two threads together at about 500 to 600 turns per running yard, and then taking two of the threads thus made and twisting them together in the opposite direction at about 400 to 500 turns.

Of the three class of silk above mentioned, we treat here only of reeled, or what is commercially known as "raw" silk.

Hundreds of boys and girls probably have kept and are keeping silkworms as a pleasant amusement, but for want of knowledge the cocoons are always wasted. Our object is to show how these cocoons can be utilised and reeled into a commercial article.

Cocoon-rearers must, however, bear in mind the two following essentials to reeling good silk:—First, the absolute necessity for raising good cocoons. The habit of placing the worms in paper cones to spin their cocoons must be discontinued. The result of this practice is, that the cocoons are badly shaped, irregular in size, and contain too great a quantity of loose or "floss" silk, which is a direct loss when reeling. A good cocoon is depicted in the September issue of this Journal. It should be nearly oval in shape, the outer lining of loose silk not too great, and the inner cocoon tough and strong enough to require some pressure to flatten between the finger and thumb, thus showing that it is compact and composed of a firm, continuous thread of good quality. A good cocoon contains about 1,150 feet of a continuous thread. Secondly, never crowd the silkworms together or stint their feed. A well-fed worm will naturally be healthy and strong, and make a good cocoon. The way to raise good cocoons was fully described in the September issue of the Journal.

REELING APPLIANCES.

Those who wish to make the appliances here described for themselves must first place their cocoons in the hottest sun for three or four days in order to "choke" the chrysalis. Further, it is an utter waste of time and cocoons to attempt to reel off a few dozen; remember that it takes from $3\frac{1}{2}$ lb. to 4 lb. of good cocoons to make 1 lb. of raw silk, and, as about 600 cocoons go to the pound, it will require about 2,400 of them to make 1 lb. of silk. Rather than reel off a small number, choke the chrysalides and keep the cocoons in a dry place till you have a further supply next season. The apparatus here depicted scarcely needs description. The "spreader" on the small front shaft is intended to spread the silk evenly on the reel. By means of a spiral groove on the shaft, it moves transversely to right and left, working a skein 6 inches wide. The groove is 3 inches long, $\frac{1}{2}$ -inch wide, and $\frac{1}{2}$ -inch deep. The centre of the groove should be exactly in line with the centre of the reel. The pin of the spreader is put into the groove, and the butt end screwed down to the rail so as to allow free play. A belt connecting the two shafts completes the reel. The construction of the spreader is shown in Plate XXVIII. The "croisure" used consists of three discs for twisting the filaments into two threads. These discs are of two sizes; two are 5 inches in diameter, 1 inch broad, and $\frac{1}{8}$ -inch thick, and one is 4 inches by $1\frac{1}{2}$ inch by $\frac{1}{8}$ -inch. The smaller disc is placed between the two larger ones; four segments of a circle a little thicker than the small disc are carefully glued round, and the two outside discs fastened together by screws or rivets through these segments, so as to allow of the inner one revolving freely. The inner disc will protrude three-quarters of an inch inside. Bend two pieces of brass wire about $\frac{3}{4}$ -inch in length into eyelets, and fasten them one on each side of the inner rim; then make two

little wooden knobs, like violin pegs, only much smaller, and fasten these on the flat of the inner disc opposite the eyelets. These serve as handles to twist the disc round. Now mount the three discs on an upright 9 inches by 1½ inch by 1 inch, and fix the upright on the plate. The figure here shown is a modification of the "tavelette," or Italian system of forming the "croisure," the principle being to use one thread in reeling and twist it on itself.

This completes the apparatus, as shown on Plate XXVIII. (without the tavalette).*

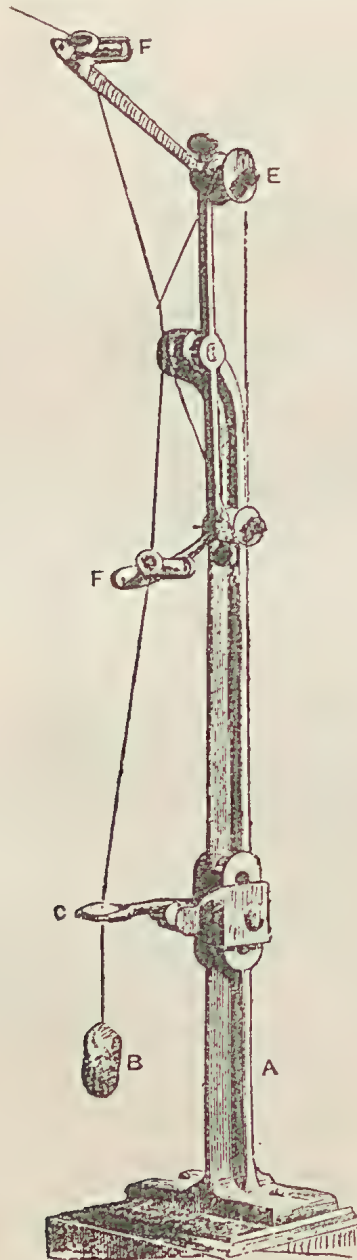

In addition to the above, an ordinary tin washing basin and a brush are required. The basin may be fitted into a hole cut for the purpose in the table, and a spirit lamp placed under it on a shelf. The brush is just a bundle of twigs or fibres from a millet broom, about 6 inches long and 1 inch in thickness.

* This apparatus may be seen in the museum of the Department of Agriculture and Stock.

THE REELING PROCESS.

The cocoons must first be sorted into grades, those of the same size and colour being put together. Reeling can only be successfully done by experience; no amount of written explanation will make a skilful reeler. The water must not be kept at boiling point after the first lot of cocoons are put into the basin. Boiling point is necessary to cook the cocoons, so as to soften their "gluten," and thus allow of their being unwound easily. Whilst reeling, the temperature of the water should be about 180 degrees Fahr. If the cocoons do not unwind easily, the water must be brought up to this temperature.

Place a double handful of cocoons in the water; then, with the brush, dab the cocoons under the water for two or three minutes (this is the cooking process); then brush them over until the fibres of all are attached (called brushing). Take these in the left hand, and with the right hand keep drawing up and putting into the left all the floss silk till all the cocoons are attached by one clean thread. This is called "purging."

Now take the threads of five cocoons, and twist them between the finger and thumb, and pass this through one of the holes in the "filière" (C); then through an eyelet in the twisting appliance, then through the eyelet of the spreader, and thence on to the reel. Now take another five cocoons, and do the same. There will now be two threads on the reel, and, in order to consolidate the filaments of the five cocoons comprising each thread, a twist will have to be given, and this is done by turning the inner disc round from left to right; from six to eight turns will be sufficient. This twisting or crossing the threads has only to be done at the start and after each break in the thread, not kept up continuously so long as the threads continue winding on the reel.

Now start the reel. It takes two people to do the reeling—one to turn the wheel, and one to attend to the cocoons. The reel should be turned in the direction away from the cocoon basin. The five cocoons forming each thread will commence to unwind readily. As the reeling proceeds, the filament comprising each cocoon becomes so very fine that it would not bear the strain of reeling; therefore, the threads made up of the five cocoons, by the time they are half unwound, will require an additional cocoon. Then, again, one may break or be unwound more quickly than the other, and it is here where the skill in reeling comes in. The attendant at the basin must endeavour to have a regular and even thread of the same thickness throughout. The thread must also be continuous throughout the skein, so that, when a break occurs, the two ends have to be brought together and neatly tied.

In attempting silk reeling, the amateur must not be discouraged if things do not come right at first; a little determination will overcome all obstacles.

Other varieties of silkworms will be described in our next issue.

BOUNTY ON COTTON.

The Federal Bounties Act of 1907, now in force, provides for the payment of a bounty, for eight years, of 10 per cent. on the market value of cotton grown and ginned within the Commonwealth by white labour. The same bounty is also payable on the market value of cotton seed. The Minister for Customs has had under consideration certain difficulties with regard to the payment of the bounties on these products. During his visit in August last to Queensland, he found that, as a rule, 1 ton of cotton yielded 640 lb. of ginned cotton—that is, lint—and 1,600 lb. of seed. It has, therefore, been determined that the bounties are to be paid on this basis.

Tropical Industries.

CIGAR LEAF.

By R. S. NEVILL.

Now that the growing of cigar leaf has become established in some of the districts in North Queensland, a few suggestions for the guidance of intending growers will probably be of value.

If we are to find an outlet for this tobacco when the limit of local consumption is reached, it is necessary that we should produce a fine quality with a large percentage of wrappers and binders. To do this we must strive for quality and not for quantity, and the greatest care must be taken in growing, cultivating, handling, and curing the crop, and under the proper conditions of heat and moisture, these latter being absolute necessities for the production of high-grade tobacco. To grow a high-grade wrapper, tropical conditions are necessary—either natural, as are found in tropical districts, or artificial by covering the fields with tents or slats, as is done in temperate and subtropical countries.

Wrapper leaf requires to be thin, strong, soft, and satiny in finish, with very fine, almost invisible, fibres. To accomplish this, hot humid conditions are necessary. If it is in the field in the cool months of June, July, and August, the dews and cold nights cause it to thicken, grow coarse, rough, and gummy, and to cure dark—all objectionable in the cigar wrapper. The time for beginning to sow seed beds is October; and for transplanting, December and up to the middle of January. Planting may be continued until the middle of February; but a sucker crop should not be taken from the crop planted after the middle of January. As soon as the final crop is taken off, the ground should be ploughed, and kept clear to prevent shoots from growing, and thus minimising the insect pest and preserving the fertility of the land. (See pamphlet "How to Cut Tobacco.")

The most convenient and economical way to hang it on the stick is to sharpen the stick at one end; and, when you want to put the tobacco on it, thrust it into the ground at an angle of about 45 degrees, and then place the plants astride it.



— Showing how to place tobacco on stick —

It can thus remain in position until it is desired to take it into the shed or scaffold.



— Cutting Tobacco —

For convenience while cutting, it is advisable to construct a scaffold to hang your tobacco on after sticking it; and you can thus go on with your cutting and sticking in the afternoon until night, and take it into the shed the following morning.

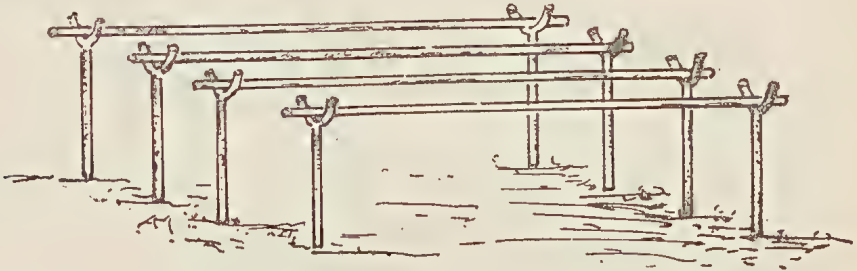

— Scaffold —

In putting the tobacco on the scaffold, it may be crowded up close, but must not be thick on the sticks.

It is important that farmers should be careful in assorting and classifying their crops, if they are to get the best prices, or if a good reputation for our tobacco is to be established. All rubbish should be thrown out, and nothing but serviceable leaf put in; dead, trashy, badly mutilated, badly sunburned, and dirty leaves should be discarded.

The handling should be neat; and in packing it should be placed in the cases straight, smooth, and even.

Neat and honest handling pays.

In curing, the shed should be carefully looked after, and care taken in filling it. The middle of the shed should be filled first, that it may get plenty of ventilation in the first stages of curing. In the early stages of curing, the ventilation should be well looked after, keeping doors and windows open during

the day when the weather is fine. If hard winds prevail, all openings on the windward side should be closed. When the tobacco begins to dry and take colour, then close sheds in daytime and open at night. This keeps a fairly uniform temperature, besides causing the tobacco to soften at night, and assists the colours to blend and become uniform.

Spotchy coloured leaves are undesirable. When the leaf has fully dried, keep shed closed, except in soft weather or at night when you want to get it in handling condition.

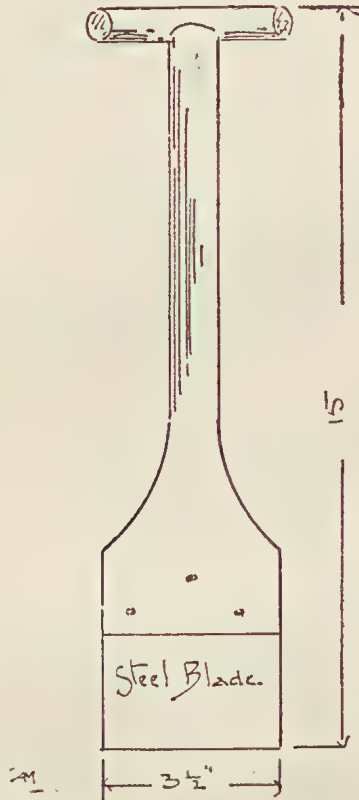

Knife for Cutting Tobacco —

I wish to impress upon growers that the advice given from time to time, for all stages of the crop, is not theory, but the experience of the best growers, and the new hand at the business who thinks he sees a better method and acts upon it is likely to pay for his method, either in the cost of production or the price of his crop. The plan of shed submitted is the latest approved by the experts of the Department of Agriculture in the United States, and it is advised that in building sheds the plan should be as nearly copied as possible.

A NEW IMPORTANT DWARF RUBBER

named "Ecanda," which yields good latex from the root, has been obtained, it is said, from the neighbourhood of Lake Nyassa, in Africa. In 1906, Mr. C. E. de Mello Geraldcs, Professor in the Instituto de Agronomia e Veterinaria, at Lisbon, published an article dealing with a new rubber plant known in Benguela as "Ecanda," or "Marianga"; and in 1907 a short abstract from the paper appeared in the "Indian Rubber World" (Vol. XXXVI, p. 300).

About the same time (says the "Ceylon Tropical Agriculturist"), a portion of a tuber was submitted to Kew, for identification, by Mr. Spencer Brett. It was made out to belong most likely to the Asclepiadaceous genus, *Raphionacme*. Later on, Kew received from the Companhia de Moçambique a number of healthy specimens of "Bitinga" tubers, or tubers of the plant from which the Bitinga rubber is extracted. They were evidently identical with the tuber communicated by Mr. Brett, and stated to have come from West Africa. The tubers have been grown in the Royal Gardens; and one of them flowered early in March of the present year. Following is a general account of

THE PLANT AND ITS PROPERTIES.

The "Bitinga" plant agrees very well with the description and figures given by Professor Geraldes of the "Ecanda" plant, and there is practically no doubt that they are identical. It is a new species of *Raphionacme*, nearly allied to *R. Welwitschii*, Schlechter and Rendle, a native of Central Angola, and is described below as *Raphionacme utilis*, Brown and Stapf. It differs from all the rubber plants already known, in so far as it is a dwarf herbaceous plant with a fairly large subterrestrial tuber abounding in caoutchouc. As practically all our knowledge concerning the distribution, properties of the plant, and the process of working it is at present confined to what we may learn from Professor Geraldes' article, a translation of the more important paragraphs is given here:—

"The interest attaching to the 'Ecanda' or 'Marianga' rests not only on the fact that we have to deal here with a new species, and, moreover, one which is morphologically different from all the other known rubber plants, but also, and more especially, as I believe, on its capacity of producing first-class rubber and the facility of working it, in which respect it has no rival. The 'Ecanda' is a herbaceous, stemless plant, with a tuber-shaped root fairly

LARGE AND RICH IN LATEX.

"From experiments made in the interior of Benguela, in order to find out the best process for the preparation of Ecanda rubber, I came to the conclusion that the only rational and practical method is by crushing the roots and treating the latex thus obtained by one of the processes of 'lato-borrachificação externa' (coagulation of the latex after extraction). It is evident that the method of first extracting the latex very much simplifies the preparation of rubber, and clearly results in considerable economy. The 'Ecanda' or 'Marianga'* is found in the treeless, sandy, and alluvial tracts (anháras) of Bailundo and Bihé and the Xánes (sandy and treeless tracts) of the region between the Rivers Kwanza and Zambese (Ganguellas), the home of the Otarampa (*Carpodinus chylorrhiza*).† Those tracts occur locally, as a rule, near the headwaters and along the banks of the rivers, occupying, sometimes, vast areas, and it is in their drier parts that the 'Ecanda' thrives. The altitude of the region where the 'Ecanda' grows is from 4,000 feet (Ganguellas) to 5,500 feet (Bihé).

"As stated, the laticiferous tubes of the 'Ecanda' are found spread all over the pulp of the root; at the same time the latex, being very concentrated, coagulates rapidly in contact with air. It is, therefore,

NOT POSSIBLE TO EXTRACT IT ENTIRELY FROM THE ROOTS BY MEANS OF INCISIONS.

"The extraction of the rubber direct from the roots, necessitating, as it does, first prolonged boiling and then crushing, followed by repeated washing,

* 'Ecanda' is the name by which the species (which occurs in Bailundo and Bihé) is known to the Bailundos and Bihanos; and it is, I assume, identical with the species known to the Lutzases (Ganguellas) as 'Marianga.'

† I suppose that the 'Ecanda' also occurs in the Nana of Xifumage (an affluent of the Zambesi which I have crossed), a vast, treeless, sand, and humus plain to the north-east of the district of Benguela. But when I traversed it the natives had set fire to it, as they are used to do, and the whole vegetation was destroyed.

is not practical, since, apart from the tediousness of the process, it implies necessarily the use of chemical agents in order to secure the complete separation of the caoutchouc from the pulp by the disorganisation of its tissues. And even so, unless dissolvents are used for the purification, the rubber remains somewhat impure, as may be well imagined.

"But to my great satisfaction I made sure that it was possible to extract the latex of the 'Ecanda' (although mixed with the sap of the roots) with great ease by means of simply crushing the roots. To extract the latex, proceed as follows:—After having washed the roots well, cut them into several pieces at a right angle to their greatest diameter, and subject them to a slight pressure in a copying-press. When the liquid ceases to flow, raise the top of the press, turn the pulp, and subject it anew to slight pressure. Repeat these operations as long as the liquid comes out yellowish and without streaks of white—that is, to the point when the latex is completely extracted and only root sap continues to flow.

"To obtain this result, it is necessary to extract from the roots, on the average, 77·7 per cent. (of the weight) of the liquor; hence the latex is much diluted (1·5 per cent. of the liquid extracted from the roots should, on the average, be pure latex). Having found a practical process for extracting the latex, I tried now to determine the best method for coagulation. I obtained good coagulation with alcohol or brandy whenever the latex was not very much diluted. This process is evidently not economical, as the coagulating agents are dear. . . . Acetic acid, sulphate of aluminium and potassium, phenol and chlorate of sodium do not act on the latex diluted with root sap. . . . Other coagulating agents I was not able to try. . . . It is, however, probable that coagulation of the latex of 'Ecanda' may be obtained with other agents, even when it is diluted with root sap. The process of skimming leaves much to be desired, since, in my experiments, I have never succeeded in extracting by this method more than half of the caoutchouc contained in the latex. . . . I also studied the effect of heat on the liquid obtained by pressing the roots of the 'Ecanda.' 'If the liquid is subjected direct to the action of fire, a skin forms on the surface, like that on boiled milk, consisting of caoutchouc. If this skin is removed in the measure as it forms, its production ceases after some time, and when at length the liquid is completely evaporated a copious yellow and viscous residue is left. By

SUBSTITUTING A HOT BATH FOR DIRECT FIRE

and proceeding in the way just described, there also remains a yellow and viscous residue, but it is less copious. In this way I obtained a greater percentage of caoutchouc which was of greater elasticity than that produced by coagulating direct over fire. Thus, by using heat as the coagulating agent, I always obtained, beside the caoutchouc, a more or less copious residue of a yellow and viscous substance. Now, it is well known that generally caoutchouc, if subjected to temperatures above 35 degrees C., gradually loses its elasticity, and turns viscous, until at 170 degrees to 180 degrees C. it is converted into a thick liquid much resembling molasses. Therefore, it might be supposed that the residue mentioned above also consisted principally of resinified caoutchouc.

"My suspicion was confirmed when treating the latex by a mixed process of skimming and spontaneous desiccation.‡

‡ To extract the rubber by this method I proceeded as follows:—I poured the liquid obtained by the crushing of the 'Ecanda' roots into enamelled iron dishes, so as to form a layer 1 cm. thick. After a while, in everyone of the dishes and adhering to their sides, a skin of rubber formed on surface of the liquid. This skin I removed, and so I went on for two days—the duration of the experiment—new skins continuing to form, but every time less thick. Then the production of skins ceased. But, to make sure whether the liquid still contained caoutchouc, I left it in the dishes until the evaporation was complete, which was the case five days after the commencement of the experiment. As the dishes were exposed to the air, and the latex somewhat caught the sun, I believe that the little yellow and viscous residue which formed consisted to a small extent of resinified rubber.

“By this method I obtained a much higher percentage of rubber and only a small residue, consisting likewise of a yellow and viscous matter. However, the rubber was less elastic than that obtained by coagulation in the hot bath. This is not surprising, seeing that the rubber prepared by the latter process contains all the components of the latex and the root sap (excepting the greater part of the water), and, besides, I had not been able to strain the liquid, having no metal net nor adequate strainer with me.

| Processes employed. | Percentage of | | Loss by Drying
per Cent. |
|---|--------------------------|-------|-----------------------------|
| | Raw Rubber per
Green. | Dry. | |
| Coagulation over fire | 2'90 | 1'870 | 35'50 |
| Coagulation in the hot bath... .. | 3'54 | 2'415 | 33'09 |
| Skimming and spontaneous desicca-
tion | 13'00 | 6'360 | 51'60 |

“In order to determine the

PERCENTAGE OF PURE CAOUTCHOUC OBTAINED

by these processes, I analysed the samples of 'Ecanda' rubber prepared in Benguela, in the chemical laboratory of the Instituto de Agronomia e Veterinaria, with the following results:—

RUBBER OBTAINED BY COAGULATION IN THE HOT BATH.

| | Per Cent. |
|---|-----------|
| Caoutchouc | 88'025 |
| Resins | 4'725 |
| Substances soluble in water | 1'100 |
| Substances soluble in alcohol at boiling point | 1'300 |
| Water | 1'082 |
| Impurities not determined | 3'768 |

RUBBER OBTAINED BY SKIMMING AND SPONTANEOUS DESICCATION.

| | Per Cent. |
|---|-----------|
| Caoutchouc | 71'925 |
| Resins | 3'300 |
| Substances soluble in water | 2'950 |
| Substances soluble in alcohol at boiling point | 1'385 |
| Water | 3'154 |
| Impurities not determined | 16'926 |

“Thus I obtained by coagulation in the hot bath 2'125 per cent. of chemically pure caoutchouc, calculated from the weight of the fresh root; and, by the mixed method of skimming and spontaneous desiccation, 4'574 per cent. of pure caoutchouc—that is, I obtained by the latter process more than twice the quantity of pure caoutchouc than by the first.

“It follows, therefore, that, of the processes which I tried, it was the process of skimming and spontaneous desiccation by which I obtained the best result. The great drawbacks inherent in that method are, however, aggravated when it is applied to the treatment of a liquid resulting from the crushing of the Ecanda root, and that makes it hardly practicable.”

SISAL HEMP IN SOUTHERN QUEENSLAND.

Mr. T. H. Wells, of Farnbro', has been busily engaged in forming a sisal plantation in the Childers district, a portion of which has come to maturity, or, rather, to that stage when the first crop of leaves is ready to be taken off. Mr. Wells has successfully overcome all the preliminary difficulties in establishing his plantation, and, having installed some very up-to-date machinery (the Finnigan-Zabrieski scutching machine), has placed a quantity of excellent fibre on the market.

Whilst this work was proceeding in the Central district, Major A. J. Boyd has been equally hard at work establishing a plantation in the Tingalpa district, near Brisbane. Of the 69 acres under sisal, none is as yet over four years old, but the plants are thriving; and it is hoped to obtain machinery and produce a fair quantity of fibre next year. Here, also, the initial difficulties were great. The land was heavily timbered; and two years ago, owing to an abnormal growth of grass, when bush fires were raging in the district, the plantation was swept by fire, fences and buildings being destroyed before the fires could be subdued. Singular to say, scarcely any damage was done to the plants, as may be seen by the accompanying illustration of a portion of the plantation. Owing to the undulating nature of the land, only a small portion of the plantation can be shown. In the nurseries, there are some 20,000 plants awaiting transplanting as soon as present contracts for clearing and holing are completed. Some *sansivieria* has been planted, but the climate is not favourable to its rapid development. The same may be said of ramie, of which some plants were put in as an experiment.

Some 16 acres of sisal have been planted at Peel Island, where the plant thrives well. A portion of this has long been ready for cutting, and during last month a commencement was made, the leaves being sent to St. Helena for treatment.

SISAL HEMP AT ST. HELENA.

To those who are interested in the cultivation of sisal hemp, a visit to the Penal Establishment at St. Helena would not fail to afford a most valuable object lesson. It is true that the soil on the island is rich; but for a long series of years forage crops, lucerne, and sweet potatoes have been grown for the use of the dairy stock on the island, and of late it has been found advantageous to apply manure to the land. Whilst a considerable amount of manure is obtained through the medium of the dairy and horse stock, a far greater proportion is derived from a kind of peat which is present in large quantities on the seashore. This is dug out, and put in heaps to allow the salt to leach out of it, when it is applied with good effect to the soil. We have already, in previous articles, described the original plantation of sisal, which was, in point of fact, merely a narrow strip planted on the edge of the western slope to act as a breakwind to shelter the other crops. About four years ago a larger portion was systematically planted on what had been a lucerne field. Later on, the steep slope facing the sea was planted. The former plot was kept clear of weeds, but the steepness of the latter precluded any attempt at cultivation, and the sisal plants disputed the land with tall weeds and grass which at times overtopped them. All that was done to these plants was to occasionally chop down the weeds and undergrowth. On the cultivated plot, the couch grass took possession, and cattle were put on to graze it down. This they did without any damage to the sisal plants, and no other attempt was made to get rid of it. The growth made by both these plots is most surprising. The plants everywhere are of great size, with fine healthy leaves from 5 to 6 feet in length, from fifteen to twenty of these being ready for taking off each plant. It is unfortunate that the area available for this crop is so small. If 300 or 400 acres could have been planted, the returns would, at the prices for the fibre which have been paid for the St. Helena output during the past two or three years, have been very large.

During the past month, the small Lehmann decorticator, driven by a 6½-h.p. Campbell oil engine, has been engaged on preparing fibre from leaves produced on the plantation at Peel Island, which are cut, taken over to Dunwich, and thence by steam to St. Helena. It may here be remarked that it is distinctly laid down in the pamphlet on "The Sisal Industry in Queensland," issued by the Department of Agriculture and Stock, that no more leaves should be cut than can be worked off during the day, except that sufficient leaves should



WOOLAHRA PARK SISAL PLANTATION, BROADWATER, LOGAN ROAD.

remain over to carry on next day until fresh supplies come in. So many leaves, however, were sent from Peel Island at one shipment that a fortnight's work will be needed to get through them. The result, as pointed out by Mr. Bowden, the chief warden at St. Helena, is that the work of cleaning the leaves is almost twice as great as that required for leaves freshly cut. We did not visit Peel Island to note how the cutting is being done; but, judging by the leaves sent to the machine, much that is immature has been cut, and this, taken in connection with damaged and short leaves, will necessitate either laborious sorting or the sale of the whole of the fibre as second grade.

As for the work at St. Helena, under Mr. Bowden's superintendence, it goes on most methodically. Mr. Bowden's experience and enthusiasm in the work have enabled him to train certain men to the work, and to prepare the fibre to the best advantage. Under these circumstances, it would be impossible for any country in the world to produce a more beautiful or stronger or longer fibre than that of St. Helena. "

SUGAR-GROWING IN QUEENSLAND.

Some interesting facts concerning the rise and progress of the sugar industry in Queensland may be found in Lock and Newland Bros'. publication, "Sugar." It is there stated that "the crop of sugar in Queensland amounted, in 1879, to about 18,200 tons, or about 4,500 tons above that of the previous year. The approximate output of the four sugar districts was—

| | | | | | | Tons. |
|-------------------|------|-----|-----|-----|-----|-------|
| Southern district | ... | ... | ... | ... | ... | 2,200 |
| Central | | ... | ... | ... | ... | 5,750 |
| Mackay | ... | ... | ... | ... | ... | 9,500 |
| Cardwell | ... | ... | ... | ... | ... | 750 |

"The output for 1880 was estimated at 21,000 tons.

"Throughout Moreton Bay, previous to its separation in 1859 from New South Wales and its formation into Queensland, the sugar-cane was cultivated in the gardens of several people, so that there was little doubt as to the possibility of its culture.

"The first sugar known to have been produced in Queensland was made by Mr. Buhôt, of Barbados, from cane grown in the Botanic Gardens, Brisbane, in May, 1862. In 1863, Captain Louis Hope had 20 acres under cane. By the end of 1867, there were 2,000 acres under cane, and the 6 mills in existence manufactured 168 tons of sugar.

At the close of 1869, there were 28 mills at work, crushing the cane from 1,230 acres out of over 5,000 acres under cultivation. In 1875, the season turned out very bad; the cane, nearly drowned in wet, became unhealthy and died, giving next to no returns. In the course of time, the evil effects of 1875 passed away; and the sugar industry has been since then more or less a success. The average yield of sugar per acre in Queensland, for the ten years ending 31st March, 1879 (and including the rust year, 1875), was as follows:—

| | | | | | | Cwt. | qrs. | lb. |
|-------------------|-----|-----|-----|-----|-----|------|------|-----|
| Southern district | ... | ... | ... | ... | ... | 24 | 0 | 25 |
| Central | ... | ... | ... | ... | ... | 24 | 2 | 9 |
| Mackay | ... | ... | ... | ... | ... | 27 | 0 | 23 |
| Cardwell | ... | ... | ... | ... | ... | 30 | 1 | 2 |
| Queensland | ... | ... | ... | ... | ... | 25 | 3 | 0 |

"Edwards, in his 'History of the West Indies,' speaks of soil in Jamaica which, with plant cane, will produce $2\frac{1}{2}$ tons of sugar to the acre. In Queensland, $3\frac{1}{2}$ tons and over have occasionally been obtained from soils newly broken up. The manufacture of rum from 1867 to 1888 was 1,842,322 proof gallons. Up to 1876 the yield was at the rate of over 2 gallons of molasses fermented to 1 proof gallon of rum distilled. During 1880 no less than 5,500 tons of Queensland-grown sugar were exported, besides large quantities of rum, treacle,

and white spirits. A plantation on the Mackay [Pioneer] River was sold for £95,000 cash. It was estimated to produce in the 1881-2 season 1,200 tons of sugar."

This was probably the River Estate Plantation, adjoining the "Cedars."

It was in 1872, however, that the rust attacked the then universally grown Bourbon cane, and in that year heavy frosts in September added to the destruction. The first mills in Queensland were horse mills, most of which were afterwards converted into steam mills. Many of the horse mills had short vertical rollers, and every cane was separately put through them. The crushing power was very small, and quite 50 per cent. of the sugar remained in the megass after passing through the rollers. The juice, after clarification, was boiled in open pans, which were constantly skimmed, and on arrival at the last pan, called the "tache," it was there boiled until it resembled the boiling of porridge, when it was ladled out, or lifted by a dipper fitting the tache, and transferred to the coolers. Draining the sugar was only resorted to in one or two mills, most of them having centrifugals. In those early days sugar was worth from £38 to £40 per ton, and, had the planters owned such mills as we see to-day in Queensland, they would have made large fortunes. As time went on, however, the vertical rollers were superseded by the horizontal. Bauer pans and Wetzel pans were relegated to the scrap heap, and vacuum pans took their place. Most of the old pioneer planters lost heavily over their ventures; the old mills, which cost from £500 to £1,200, were abandoned; and the succeeding generation brought the Queensland sugar industry to its present state of perfection.

Statistics.

COMMONWEALTH METEOROLOGY. RAINFALL OF QUEENSLAND.

TABLE SHOWING THE TOTAL RAINFALL FOR EACH MONTH OF THE YEAR IN THE AGRICULTURAL DISTRICTS OF QUEENSLAND.

| STATIONS. | 1907. | | | | | 1908. | | | | | | | |
|-----------------------|-------|-------|------|------|-------|-------|-------|-------|--------|-------|-------|-------|------|
| | Aug. | Sept. | Oct. | Nov. | Dec. | Jan. | Feb. | Mar. | April. | May. | June. | July. | Aug. |
| <i>North.</i> | | | | | | | | | | | | | |
| Bowen | 1.28 | 0.51 | 0.06 | 3.71 | 6.39 | 10.14 | 5.63 | 9.46 | 3.73 | 0.99 | 0.45 | 0.88 | 0.51 |
| Cairns | 0.39 | 1.35 | 0.69 | 5.35 | 28.33 | 27.02 | 8.03 | 20.60 | 5.99 | 3.05 | 0.59 | 3.70 | 2.12 |
| Geraldton | 4.66 | 1.36 | 1.42 | 6.45 | 33.82 | 44.39 | 13.27 | 39.00 | 14.23 | 18.52 | 2.64 | 8.11 | 3.06 |
| Herberton | 0.11 | 0.12 | 0.17 | 3.41 | 9.57 | 9.29 | 5.02 | 8.92 | 1.40 | 0.38 | 0.31 | 2.36 | Nil |
| Hughenden | Nil | Nil | 1.66 | 0.66 | 7.75 | 0.98 | 5.18 | 6.91 | 0.30 | Nil | 0.05 | 0.68 | Nil |
| Kamerunga State Nurs. | 1.15 | 1.19 | 0.53 | 2.76 | 29.82 | ... | 7.47 | 25.75 | 4.60 | 3.363 | 0.76 | 4.85 | 1.58 |
| Mackay | 0.25 | 0.12 | 0.12 | 5.76 | 9.70 | 9.28 | 3.83 | 17.43 | 14.82 | 3.25 | 1.29 | 1.65 | 0.71 |
| Rockhampton | 0.47 | Nil | 0.47 | 3.72 | 4.42 | 3.84 | 9.64 | 9.77 | 2.62 | 0.85 | 0.10 | 1.08 | 0.84 |
| Townsville | 0.07 | 0.14 | 0.03 | 2.82 | 24.26 | 12.21 | 6.69 | 9.03 | 0.38 | 2.22 | Nil | 1.70 | ... |
| <i>South.</i> | | | | | | | | | | | | | |
| Biggenden State Farm | 0.96 | 0.24 | 1.99 | 2.50 | 5.55 | 2.37 | 9.82 | 9.84 | 2.97 | 0.74 | 0.43 | 0.49 | 2.33 |
| Brisbane | 0.79 | 0.10 | 1.37 | 4.25 | 3.21 | 2.80 | 8.43 | 18.19 | 2.45 | 2.40 | 0.17 | 0.77 | 2.83 |
| Dundaberg | 0.43 | Nil | 1.70 | 2.90 | 2.99 | 4.77 | 2.82 | 7.35 | 4.13 | 0.67 | 0.39 | 0.75 | 1.56 |
| Dalby | 0.71 | 0.15 | 0.69 | 5.18 | 1.44 | 0.17 | 4.88 | 7.61 | 0.11 | 0.37 | 0.63 | 0.14 | 1.80 |
| Esk | 0.81 | 0.57 | 0.50 | 3.76 | 3.72 | 2.61 | 10.06 | 17.04 | 2.83 | 1.07 | 0.23 | 0.46 | 2.75 |
| Gatton Agric. College | 0.56 | 0.15 | 0.71 | 3.01 | 4.55 | ... | 3.38 | 10.74 | ... | 0.10 | 0.16 | 0.6 | 2.71 |
| Gladie State Farm ... | 0.10 | 0.16 | 0.61 | 1.57 | 4.42 | 0.20 | 7.17 | 6.25 | 0.02 | 0.112 | ... | 0.40 | 1.27 |
| Gympie | 0.17 | 0.47 | 1.20 | 3.05 | 5.49 | 6.26 | 11.77 | 80.8 | 1.87 | 2.00 | 0.38 | 1.16 | 2.87 |
| Ipswich | 0.43 | 0.05 | 0.78 | 4.45 | 3.40 | 1.32 | 6.63 | 13.77 | 2.71 | 1.14 | 0.12 | 0.47 | 3.23 |
| Maryborough | 0.93 | 0.25 | 2.74 | 3.49 | 5.81 | 5.62 | 8.07 | 11.40 | 2.52 | 1.05 | 0.46 | 0.81 | 1.98 |
| Roma | 0.42 | 0.04 | 1.04 | 3.70 | 2.51 | 0.01 | 6.38 | 2.51 | 0.22 | Nil | 0.55 | 0.63 | 1.38 |
| Roma State Farm ... | ... | ... | ... | ... | ... | ... | ... | ... | ... | ... | ... | 1.27 | 0.73 |
| Tewantin | 0.95 | 0.55 | 1.05 | 3.12 | 7.36 | 10.42 | 12.47 | 14.39 | 7.59 | 8.66 | 0.75 | 1.97 | 2.70 |
| Warwick | 1.37 | 0.01 | 1.37 | 3.25 | 3.13 | 0.76 | 4.62 | 6.65 | 1.40 | 0.15 | 0.80 | 1.24 | 2.50 |
| Westbrook State Farm | 1.78 | Nil | 1.08 | 4.76 | 3.23 | 0.43 | 8.03 | 1.41 | 1.40 | 0.05 | ... | 0.49 | 1.97 |
| Yandina | 0.68 | 0.80 | 1.44 | 2.87 | 3.05 | 8.37 | 14.47 | 16.62 | 5.45 | 4.59 | 0.58 | 2.64 | 2.18 |

NOTE.—The rainfall data in this table are compiled from telegraphic reports, and must be considered approximate only.

GEORGE G. BOND,
Divisional Officer.

Animal Pathology.

NOTES ON THE PRESENCE OF TWO STOMACH WORMS IN CALVES HITHERTO UNRECORDED IN AUSTRALIA.

By SYDNEY DODD, F.R.C.V.S.,

Principal Veterinary Surgeon and Bacteriologist.

In a recent article in the "Agricultural Journal" on stomach worms, reference was made to these parasites being a source of loss amongst calves. It was stated that the worm most prevalent in parasitic gastritis (stomach worms) in Queensland was the twisted stomach worm (*Strongylus contortus*). At the time of writing, although I suspected that this worm was not the only one present in affected animals, yet for various reasons I had not the opportunity to demonstrate the presence of any other species in this State until recently.

A short time ago such opportunity presented itself, when I had occasion to visit a farm on which a number of young calves were dying from a disease unknown to the owner, who was an experienced farmer.

On my visit several of the surviving calves were showing typical symptoms of stomach-worm infestation. The animals were weak and in very poor condition, although there was plenty of food for them and their appetites were good. The droppings had collected around their hindquarters and tail in some cases. Their eyes were very pale, and there were marked dropsical swellings under the jaw ("Bottle"), and also around the lower parts of the legs, but to a lesser extent. One of the calves showing marked symptoms was killed, and a *post-mortem* examination made immediately. The blood was very watery, and the tissues immediately under the skin in a very dropsical condition, the fluid draining away in a very marked manner. The kidneys were also dropsical, and there was more than a normal amount of fluid in the heart bag. The spleen was normal in size. On opening the fourth or true stomach, a quantity of sand was observed, but very little food. On turning out the stomach contents, there were seen to be enormous numbers of small worms wriggling about. Those visible were easily distinguished as the twisted stomach worm. Some of the stomach contents were removed for further examination. On the worms being separated from the stomach contents, it was found that the twisted stomach worm (*Strongylus contortus*) was not the only one present, but that there were large numbers of a much smaller worm—so small, indeed, that they may be easily overlooked in the turbid contents of the stomach, but they can be seen if they are placed in a shallow glass vessel with a little clean water. Microscopical examination of these small worms revealed the fact that they belonged to two species quite distinct from *Strongylus contortus*. These two worms are named, respectively, *Strongylus cervicornis* and *Strongylus gracilis*. The former was first described by Sir J. MacFadyean in 1896. He found it to be the cause of an alarming number of deaths in lambs in various parts of England; and he named it "cervicornis" owing to the bursa on the caudal extremity of the male having some resemblance to a stag's horn. This worm has been found to exist in New Zealand, but I believe this is the first occasion on which its presence or that of the other small stomach worm (*Strongylus gracilis*) has been recorded in Australia. *Strongylus gracilis* was also first described by MacFadyean, and has been found in cattle suffering from parasitic gastroenteritis in England, also in the lining of the stomach of sheep, horses, and pigs.

Although it is recognised that an anatomical description of these worms is of very little assistance to a stock-owner, it is thought that an extract from the description will be of interest and of some use in enabling these two worms (*Strongylus cervicornis* and *Strongylus gracilis*) to be distinguished from the more prominent *Strongylus contortus*:—

STRONGYLUS CERVICORNIS.—"The males are smaller and less numerous than the females. The female is usually about two-fifths of an inch and the male about three-tenths of an inch long."

STRONGYLUS GRACILIS.—"Colour dull white. The female measures from one-seventh to one-ninth of an inch in length, and the longest males are a little over one-ninth of an inch long."

Strongylus contortus, on the other hand, is from one-half to one and a-half inch in length.

The life histories of *S. cervicornis* and *S. gracilis* are at present unknown; but it is probable that they have histories similar to that of the twisted stomach worm—that is, a certain period of their development is passed on pastures, and that their whole life is not spent in the alimentary canal of their hosts.

One of the reasons for publishing this note is that it is quite probable occasions arise where from visible symptoms everything points to parasitic gastritis (stomach worms), and yet to a casual observer, on making a *post-mortem* examination and on opening the fourth stomach, apparently worms are not in sufficient numbers to justify the diagnosis of stomach worms. In this case the method previously recommended should be adopted—that is, of putting a little of the stomach contents or, better, a scraping from the lining of the fourth stomach into a shallow flat-bottomed glass dish with a little clean water. The small worms can then be easily seen, if present. Treatment should be carried out on the same lines as recommended in Bulletin No. 1, taking care, if possible, to remove the affected animals from swampy ground to a dry paddock where there is abundance of dry feed.

Science.

WATER-FINDING.

Under the heading of "The Divining Rod," we have published several interesting articles on the subject of water-finding by means of a forked rod in the hands of someone gifted with the power of discovering subterranean water. Such a gift is one not to be despised in a country like Australia, some parts of which are devoid of surface water. We believe that there are some very successful water-finders in Queensland, but their modesty is so great that we seldom hear of their doings and of their methods from themselves. In New Zealand a clergyman has a wonderful gift in this direction—the more wonderful since he uses no rod whatever. He has been very successful in locating water in that country, and has given some account of his methods to a representative of "The New Zealand Farmer," from which journal we take the following account of the Rev. Mr. Mason's operations:—

Considering that the fact of water-finding is as well established as the demise of the late Queen Anne, it is astonishing how many people know absolutely nothing about it, and how many look upon it in the same light as telling fortunes by cards or tea-cup reading, and dismiss it all as "fudge." The divining rod has probably at times been used as a means of deception, but so have other things which, in the hands of the proper persons, are instruments for good; and the broad fact of being able to locate the position of underground streams of water, or the pools from which artesian wells are tapped, is as unassailable as the statement that the needle of the compass points north. The power is such a remarkable one that no wonder it was in by-gone days classed with the black art by the ignorant, and even in the light of present-day knowledge one cannot see it manifested without a feeling of astonishment and something approaching awe. The fact that the power is possessed by so comparatively few, and that thousands could walk over the same ground till they dropped from sheer exhaustion without experiencing any of the sensations which tell the water-finder that he is over living water, is in itself sufficiently remarkable, and is quite enough to prove to the "what I don't understand I don't believe" class of persons that the whole thing is fudge.

It is usual for water-finders to carry a forked stick, but Mr. Mason dispenses with this, and simply stretches his hands out. As soon as he comes over living water, he is affected with a trembling which seems to be in proportion to the size of the body of water over which he is standing. The pipe at his feet marks the spot at Richmond Hills where water was found in abundance at 50 feet after an unsuccessful attempt had been made at twice that depth only a few yards away.

Round about Auckland there are a good many settlers whose opinions on the subject are very different from those they held not so very long ago. At Otahuhu lives the Rev. Harry Mason, vicar of Holy Trinity Church, and he is one of the few in New Zealand who have the gift of locating water that is hidden from the ken of ordinary mortals. There are hundreds of well-authenticated instances in which he has found water for people who were badly in need of it, and, as the late Mr. Samuel Luke once said to the writer, "I don't know what the people out our way would have done this summer if it had not been for Mr. Mason." The numerous cases cited in support of his success, and also the somewhat unusual circumstances—that he was a clergyman, and did not make a profession of finding water—led a "New Zealand Farmer" representative out to the village one day recently to investigate first hand. After some

difficulty—for he has a cordial hatred of publicity—Mr. Mason was induced to talk about this gift, or power, or whatever we decide to call it, and, as he had had the advantage of a scientific education, his remarks on the matter are full of interest to the student of the question, and those who know nothing of it will see that water-finding is simply a manifestation of some force of which we have as yet only a very elementary knowledge.

DISCOVERING THE POWER.

“It is a rather peculiar story,” said Mr. Mason, in answer to a question as to when he first became aware that he had the power. “About ten years ago, when I was in the Taranaki district, I met a Dr. —, who was travelling leisurely round the world, and he possessed the gift of finding water with the divining rod, or at least he said he did, though I did not give any credence to his claim, as I was a sceptic in those days. One day while on a farm in the neighbourhood, the owner of the place was complaining about the scarcity of water for his stock, and I said, laughingly, ‘Oh, you should have Dr. — here. He would soon find you water.’ They wanted to know what the doctor did, and I cut a rod from one of the trees near by, and, holding it like Dr. — used to, I walked a few yards to show the farmer how it was done. Suddenly, to my surprise, I found that I was affected just as the doctor had been, and the stick snapped under the influence that was exerted. This was the first indication I had of possessing the power, and, as I tell you, I had previously laughed at the idea of there being anything in it.”

“But I understood that you did not use the rod?”

“Not now. And that is another peculiar story. One day, while working in the orchard, I discovered quite accidentally that I was affected without anything at all in my hands. I had just thrown down a grubber I had been using, and, after the manner of tired people, had yawned with my hands stretched out slightly behind me, when I felt a sudden trembling, and it seemed as if somebody had gripped me by the biceps and was trying to pull me backwards. Nonplussed for the moment, I pondered over the incident, and at last came to the conclusion that it must be the water. Subsequent events proved that it was so. With regard to the rod, my experience has been that it is not always reliable, as it will act in the hands of a hysterical or highly-nervous nature when there is really no water there. Nowadays I never use any rod or stick, but simply walk along with my arms stretched straight down by my side, pointing somewhat to the back. When over water, I feel the sensations that I have just mentioned, and it seems that the greater the body of water the more intense are the sensations set up.”

SUGGESTED EXPLANATION.

“Have you formed any idea or theory about this much-discussed power?”

“Yes; and, though I have not previously seen it suggested, I feel convinced that it is the scientific solution of the great disadvantage, that none have been made by men of scientific attainments, but they have all laboured under this great disadvantage, that none of them have been possessed of this peculiar gift or power, or whatever you like to call it, of being sensitive to the influence of underground water. It is known that there is a certain amount of friction in flowing water. Professor Tait, of Edinburgh, has carried out experiments which prove this, and reliable figures can be quoted from his book, but, except to those acquainted with mathematical physics, those figures would convey little information. However, to give the results of his experiments in a popular form, I may say that I gather that the force generated by this friction decreases proportionately with a rise in temperature of the water. A certain volume of water of the temperature of 40 degrees Fahr. would generate a force about half as much again as a similar volume of water at 80 degrees Fahr., the velocities of the two currents being the same. Some people say that this force is magnetic, but

I think I have proved that it is not. I have insulated myself by standing on a piece of glass and also on rubber, and still have felt it. I have also experienced it while on horseback. Another experiment tried was with a magnetic needle, which I placed close to me in many different position while feeling the influence of the water, but the needle was not affected in the slightest. No; I think it is not magnetic. It is some force that is at present unknown. We are always discovering something new in the scientific world, some new forces—the Röntgen Rays, for example—and I am convinced that this power of finding water is explainable on a scientific basis, and upon that alone. You are aware that all currents, magnetic or electrical, must complete a circuit. As illustrations, the return circuits in connection with the tramways and the telephone may be mentioned. Now, my theory is that the friction of the running water, or, rather, living water, under the ground, sets up an energy which is not all used up in raising the temperature of the water, but comes up through the ground, and, finding me a good 'conductor,' flows through my body, and seeks to re-enter the earth by way of my arms, and so complete the circuit. I think that this is proved by the fact that when I stand over stagnant water—a well, for instance, in some cases—there is not the slightest effect on me."

Mr. Mason was asked if he had any means of arriving at the probable depth the water would be found after he had located it.

"No," was his reply, "I must confess that I cannot tell, except in country where I have located a lot of different spots, as at Papatoetoe, and there it is only by analogy, of course. However, I think it probable that there is some way of arriving at a solution, and am now working on the matter in conjunction with a mathematical friend of mine. It seems to me that there may be some relation between the width of surface of ground over which the force is felt and the depth from which the force comes. Let me explain. If it is not at a great depth from the surface, it will not radiate over much ground; but if it is situated at a considerable depth it will have time to radiate fan-like over a proportionately greater area of ground. This is only a supposition, but it seems to me there is something in it."

Mr. Mason then gave demonstrations of the work, and indicated several spots on his own property where water existed, and also went over the ground across the road where the city council was boring for a supply for the abattoirs—a matter which is again referred to later on. He simply walks along with his arms by his side, his hands pointing somewhat behind, and when he comes on to ground over water he is seized with a trembling in the hands and arms, and the body bends as though he were being forced down by pressure on his two shoulders, till he stands on tiptoe. In some places the effect on him is more marked than in others—presumably owing to a greater or less body of water. If one holds Mr. Mason's wrist while his body is undergoing this contortion, one can feel a sensation not unlike that received from one of those penny-in-the-slot electrical contrivances which are so popular at fairs. Asked if he felt any after effects, Mr. Mason said there was a strained feeling in the muscles of the legs after a big day—he has located over thirty spots on some days—and he could not sleep the night after, but experienced nothing unusual beyond that; and, if he found one or two places only, he felt no inconvenience whatever. It is only when he stretches his arms down in the manner referred to that he can tell when he is over water; and, taking this in conjunction with the fact that those who use the rod must naturally exert a certain amount of force to hold it, one comes to the conclusion that there must be a certain rigidity in the muscles of the upper part of the body before the finder answers to the force generated by the running water.

Mr. Mason believes that there is some connection between the width of the ground over which he feels the sensations set up by the water and the depth at which one may get the water. Take, for instance, the lower line marked

"surface" in the diagram. If he can be affected over an area of, say, 3 yards, and the water is tapped at 50 feet, then if he be affected over a greater area, as in the second line marked "surface," the depth at which this water will be found will be so much deeper in proportion. Of course, these figures are purely supposititious.

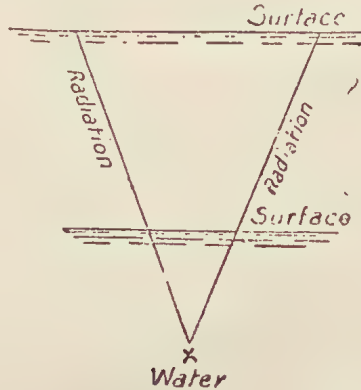

Some very interesting phenomena are met with now and again in the course of the work. While a bore was being put down at Mangere, the men, after going through scoria for a considerable distance, came across a buried tree (which was afterwards proved to be kauri), and struck a grand flow of water. Many, many centuries ago there must have been a forest there which was buried by some eruption, all the country round about being volcanic. At Mount Wellington, while looking for water for the road board, Mr. Mason found an enormous body of water right in the middle of the scoria pit which is now being worked, and that hundreds of small streams radiated from this centre all round the mountain. His investigations also proved to him that Lake St. John—about whose source there have been frequent discussions—was fed from Mount Wellington, as he traced the course of the underground streams from one to the other. On one occasion Mr. Mason located water for a man in the Waikato, and heard no more about it till one day a messenger came asking advice, as they were in difficulties with the bore. Water had come in intermittently when they had reached a depth of 184 feet, but they had gone down 350 feet without success; and, as it was getting beyond their means, would Mr. Mason tell them what to do? He replied that there was evidently some obstruction at the 184 feet, and advised putting in a charge and blasting at that spot. The man was canny, and did not like to blow away all the work of weeks, so he put in a charge at the bottom of the bore. No result. He put in another higher up. Still no result. Finally, he exploded a charge at 184 feet, and the water at once came in with a splendid flow.

General Notes.

TANNING HOG SKINS.

AMERICAN METHOD.

Hog skins make very nice leather when they are properly tanned. They are usually very greasy, and have numerous holes in them. It is very important that the tanner handles the skins carefully, so as not to increase the number of holes; and the skins must be degreased right at the start, as they will cause trouble all the way through.

The skins should be worked before they are soaked, and as much of the grease as possible must be scraped out. After the skins have been scraped out dry, they should be washed in warm sal soda water, and then worked and scraped to get the dissolved grease out. The soda solution is made by dissolving 5 lb. of sal soda in a barrel of water of about 95 degrees. The skins are put into this water, and left there about one minute; they are then put on the beam, and scraped and worked, and the dissolved grease will flow out. After this has been done at least twice, the skins should be washed in soda solution to free them from adhering grease, and then soaked for twelve to twenty-four hours in cold water. The unhairing is accomplished most readily in a solution of sulphide of sodium or patented depilatory. Fleshing should be done before the skins are unhaired.

DEPILATORIES.

A suitable depilatory is made by dissolving 10 lb. of depilatory in each 7 gallons of water in the vat; the skins are then put into the solution and stirred about for thirty-six hours, more or less, or until the hair is dissolved and the skins are ready for the lime. Wash the hair off, and then lime the skins in weak, white lime for one day; and then transfer them to stronger lime, or make the first lime stronger. From two to four days are usually required by the liming process, according to the thickness of the skins and the strength of the lime. The lime dissolves the remaining grease, and the bathing and washing remove it. A bran bath is good for drenching the skins: 50 lb. of bran soaked in warm water until it is sour and then stirred into 700 gallons of water makes a good drench for the skins; 10 lb. of sulphuric acid should be added to the drench, and the skins stirred about in the liquor for several hours until they are soft and clean.

The next work is fine hairing, and the skins should be worked out over a beam; and all the lime, dirt, and oil should be removed on the flesh side, and the skins are then ready to be scudded upon the grain. This work must be carefully done so as not to damage the grain. All the dirt and fine hairs should be removed from the grain; the skins then rinsed in warm water, and they are then ready to be tanned. On account of their porous nature, the skins absorb the tan very rapidly. Hemlock extract is the cheapest tanning material that can be used; quebracho extract tans the skins with a fine, natural grain; and a combination of the two also makes good leather.

THE TANNING PROCESS.

A paddle vat is the best to do the tanning in, as a drum is apt to tear the skins. When hemlock is used, the skins are kept in the liquor until they are struck through, the liquor being strengthened twice a day. About eight days are required to do the tanning. After they are tanned, the skins should be bleached and drummed in sumac, then washed, struck out, oiled lightly, and dried. Dampen the dry skins, and shave those that need it. Have the skins

moist and soft and give them fat liquor made of oil, soap, and degreas; give considerably less fat liquor than calf skins, and then dry the skins again. If the skins are to be coloured, moisten them with warm water, and clear the grain with borax and sulphuric acid or any other good bleaching process, and then mill in sumac again; rinse the leather, and colour it in a drum the desired shade; rinse the skins again; oil the grain with cod oil, and dry the skins again. Staking and finishing complete the work, and the skins are ready for use.

TANNING BATHS.

To tan with quebracho, make up the first tanning bath by adding dissolved quebracho extract to water in the paddle vat to make a 4-degrees liquor. To each 100 gallons of liquor add $1\frac{1}{2}$ lb. of alum and 4 lb. of salt, and plunge the liquor well. Process the skins in this liquor for thirty-six hours, or until they have assumed a light oak colour; then place them in the second bath. This is simply a clear quebracho liquor of 6 degrees. Paddle the skins in this liquor thirty-six hours; then strengthen the liquor to 10 degrees; and in about two days the skins will be completely tanned. Drum the skins in sumac; oil the grain with neat's-foot oil, and hang the skins up to dry or tack them on frames. The dry skins can then be moistened, coloured, and finished. They can also be bleached and finished without being coloured. Hemlock combined with quebracho makes a good tannage. For inner-soiling, the skins are oiled with a combination of fish and mineral oil, and are finished on the rolling machine, which makes them smooth and firm. It is of benefit to the leather to mill the skins in a lactic acid solution before tanning them; it clears the grain.—“Indian Trade Journal.”

Answers to Correspondents.

PINEAPPLE-GROWING.

NOVICE, Nudgee.—

“Novice,” as a beginner in the business of pineapple-growing, asks the following eight questions:—

1. How long a time elapses between the planting of suckers and the first production of marketable fruit?

Ans.—From 12 to 20 months (except where suckers throw fruit as soon as planted), according to the type of suckers, and the time of year when planted.

2. How long between the first appearance of fruit on the sucker and its readiness for market—summer and winter?

Ans.—Rough Leaf, about 4 months in summer—5 months in winter; Ripley Queen, about $4\frac{1}{2}$ months; seedlings, about $4\frac{1}{2}$ months.

3. How long between first fruit and subsequent fruit from the same stock?

Ans.—The stock which has borne a fruit will bear no more. The subsequent fruits follow from the suckers.

4. Should the buttons that grow on the stalk beneath the fruit be removed when the fruit is gathered? If so, why?

Ans.—Some plant the buttons from the common, or Rough Leaf; but these are of no value for planting for a marketable product. Buttons from Smooth and Ripley Queen pines are better for planting than strong plants, as the first fruit from the buttons is marketable, whilst that from the sucker is not.

5. If buttons are allowed to remain on the stalks, will they bear fruit, and at what period?

Ans.—Remove them, plant them out, and they will bear in two years.

6. Which are best for planting purposes—suckers, tops, or buttons; and how long between planting and bearing of each?

Ans.—Suckers are the best in the case of Rough Leaf pines. Tops will, it is said, produce better fruit; but it takes two years and more before they fruit. Buttons, except those above mentioned, are not worth planting.

7. Is the mealy bug really detrimental to the fruit? What means should be taken to combat it

Ans.—The mealy bug does no harm to the fruit; but it should be brushed off before marketing the latter.

8. What is the best manure for pines, how should it be applied, what season of the year is best, and how often?

Ans.—The best manure for pineapples is stable manure. If this is not obtainable, the best results will be obtained from a complete manure containing at the rate of 150 lb. of pure potash, 75 lb. of nitrogen, and 75 lb. of phosphoric acid to the acre. Bonedust by itself, applied at the rate of 1,000 lb. per acre, shows no results at first, as it is a slow-acting manure. Nitrogen is of vital importance. Green manure (cowpeas) may be ploughed in, and suckers planted the next season. Shirley's, Graziers', and Redbank manures may be applied about August, and again after the summer crop is off, to give good growth during the autumn and winter. Plough in.

We do not know of any special work on pineapple-growing in Queensland. Mr. A. H. Benson's articles in this Journal and his pamphlet on fruit culture here contain all that is needed by the novice.

Plant smooth-leaved pines in rows $4\frac{1}{2}$ feet apart every three years. They do not spread like the rough-leaved.

THE CULTIVATION OF GROUND OR PEA NUTS.

OIL, Rockhampton.—

You will find full information on peanuts in the Journal for May, 1904, and June, 1905. A very interesting account will be found, in the issue of July, 1899, of a farmer's experience in raising peanuts, by the late Mr. Charles Batten, of Pimpama.

STOMACH WORMS IN SHEEP.

R. IRVING KEYS, Biggenden.—

Grazing sheep on lucerne will tend greatly to reduce the number of stomach worms; but the ground should not be overstocked, nor the animals grazed on it continuously. It should, however, be borne in mind that green lucerne has a slightly costive effect, and with animals badly affected with stomach worms food of a dry nature is indicated.

STALLION TAX.

P. CLARKE, Ashgrove.—

There is no tax on stallions. You may safely castrate an entire even up to ten years of age. A horse-breeder says, however, that the operation should not be performed when thunderstorms are about.

The Markets.

PRICES FOR FRUIT—ROMA-STREET MARKETS.

| Article. | AUGUST, |
|--|----------------|
| | Prices. |
| Apples, per case | ... |
| Apples (Hobart), choice, per case | 11s. to 12s. |
| Apples (Hobart), medium, per case | 7s. 6d. to 9s. |
| Apples (American), poor quality, per case | 6s. to 8s. |
| Apples, New England, per packer | ... |
| Apricots, Local, per packer | ... |
| Asparagus (Westbrook State Farm), per dozen bundles | 8s. to 9s. |
| Bananas (Queensland), per dozen | 3d. to 4½d. |
| Custard Apples, per case | ... |
| Gooseberries, per quarter-case | ... |
| Lemons (Lisbon), per case... .. | 6s. 6d. to 8s. |
| Lemons, rough, per case | ... |
| Loquats (Sydney), per case | 6s. to 6s. 6d. |
| Mandarins, per case | 4s. to 5s. |
| Oranges, Queensland, per case | 4s. to 5s. |
| Passion Fruit (Sydney), per case... .. | 4s. to 5s. |
| Papaw Apples, per quarter-case | 2s. to 2s. 6d. |
| Persimmons, per case | ... |
| Pineapples, rough, per dozen | 1s. to 1s. 6d. |
| Pineapples (Ripley's), per dozen... .. | 1s. 6d. to 2s. |
| Pineapples, smooth, per dozen | ... |
| Rosellas, per sugar bag | ... |
| Strawberries, per tray | 2s. to 3s. |
| Strawberries, per dozen cardboard boxes | 5s. |
| Tomatoes, per quarter-case | 4s. 6d. to 6s. |

SOUTHERN FRUIT MARKET.

| | |
|--|----------------------|
| Apples, American, per case | 11s. 6d. to 13s. 6d. |
| Apples, Tasmanian, per case | 12s. |
| Apples, Tasmanian, Cooking, per case | ... |
| Bananas, Fiji, Gros Michael, per case | 18s. |
| Bananas, Fiji, sorts, per case | 24s. |
| Bananas, Fiji, ordinary, per case | 15s. 6d. to 16s. |
| Bananas, Fiji, per bunch | 3s. to 7s. 6d. |
| Bananas, Queensland, per case | 11s. to 12s. 6d. |
| Bananas, Queensland, per bunch | 2s. 6d. to 5s. |
| Chillies, per bushel | ... |
| Custard Apples, per case | ... |
| Gooseberries, per quarter-case | ... |
| Loquats, per case | 4s. |
| Mandarins (Local), per case | 10s. |
| Mandarins, Emperor, per case | ... |
| Oranges, Queensland, per case | ... |
| Oranges (Local), per case | 10s. |
| Oranges, Queensland, Navel, per case | 14s. |
| Passion Fruit, per half-case | 4s. |
| Pears, Victorian, per case | 20s. |
| Pears, Tasmanian, per half-bushel case | ... |
| Pineapples, Queensland (smooth), per dozen | ... |
| Pineapples, Queen's, per dozen | 4s. to 5s. 6d. |
| Pineapples (Ripley's), per dozen | 4s. 6d. to 6s. |
| Pineapples, Queensland, common, choice, per dozen | ... |
| Strawberries, Queensland, per three-quart tray | ... |
| Strawberries, Queensland, small, per three-quart tray | ... |
| Tomatoes, Queensland, choice (coloured), per box | 3s. to 5s. |
| Tomatoes; green, per quarter-case | ... |

PRICES OF FARM PRODUCE IN THE BRISBANE MARKETS FOR
AUGUST—*continued.*

EXHIBITION.

| | | | | | | | AUGUST. |
|---------------------|----|----|----|----|----|----|----------|
| | | | | | | | Prices. |
| Bullocks (Champion) | .. | .. | .. | .. | .. | .. | £21 10s. |
| „ (Guessing) | .. | .. | .. | .. | .. | .. | £18 15s. |
| „ | .. | .. | .. | .. | .. | .. | £15 10s. |
| Cows (Champion) | .. | .. | .. | .. | .. | .. | £11 |
| „ | .. | .. | .. | .. | .. | .. | £9 |
| Merino Wethers | .. | .. | .. | .. | .. | .. | 26s. 6d. |
| C.B. | .. | .. | .. | .. | .. | .. | 30s. |
| Merino Ewes | .. | .. | .. | .. | .. | .. | 17s. 6d. |
| C.B. | .. | .. | .. | .. | .. | .. | 24s. |
| Lambs | .. | .. | .. | .. | .. | .. | 18s. 6d. |

Orchard Notes for November.

BY ALBERT H. BENSON, M.R.A.C.

THE SOUTHERN COAST DISTRICTS.

November is somewhat of an off month for fruit, as the crop of strawberries is about over; pineapples, with the exception of a few off season fruit, are not ready for marketing; and citrus fruits of all sorts, with the exception of those grown in the latest districts, are now over.

Bananas should, however, be improving, particularly if the season is favourable.

The most important work of the month is the cultivation of the orchard, as, in order to retain moisture in the soil, it is essential that the soil be kept in a fine state of tilth. Where land is liable to wash, breaks should be left between the fine-worked land, or, even better, a good break of cowpea or other leguminous crop, valuable for producing nitrogen and humus, should be grown. All fruit pests should be attended to; cyaniding can be carried out where necessary, and is especially useful now in the case of the Red, Purple Mussel, Circular Black, and Glover Scales. Fruit fly should be systematically fought; all imported plums, peaches, guavas, or other fruits should be gathered and destroyed, so as to prevent the spread of the pest. Sucking bugs of all sorts should be gathered and destroyed, the egg clusters, as well as the immature and mature insects, being destroyed. Hand-gathering is as good a plan as any. Fig beetles should be destroyed by spraying with Kedzie's mixture; and the egg clusters should be destroyed whenever found.

Bananas and pineapples can be planted during the month, taking care, in the case of pineapples, not to set out suckers that will immediately throw out a fruit, but those that will become firmly established before they fruit. Examine the vineyard carefully, and keep it well worked. Look out for Oidium and Black Spot, and treat for same as recommended in the Orchard Notes for the two previous months.

Early ripening grapes will be reaching maturity towards the end of the month; but few, if any, will be ripe. In any case do not market too immature fruit; rather wait a few days longer, till it is fit to eat.

TROPICAL COAST DISTRICTS.

The main crop of pineapples will ripen during the month; and if gathered at the right time—viz., when fully developed, but not turned colour—they will carry all right South, if carefully handled and well packed. Pawpaws and granadillas are still in season, and will meet with a good Southern demand; they must be packed in cases containing only a single layer of fruit, and should be sent in the cool chamber. I am certain that a good market can be got for these fruits in both Melbourne and Sydney, particularly at this time of year, when their winter fruits are off and their summer fruits are not yet on.

Watch bananas carefully for fly. Keep the orchards well cultivated.

Only ship good mangoes South; far too much rubbish is sent to Brisbane. Good mangoes will pay to pack properly, but the common sorts, which predominate to an enormous extent, will barely pay freight, if there is a good crop. The canning of good types of fibreless mangoes of good flavour is well worth taking up commercially in the North, as a ready sale for the canned fruit can be obtained.

As in the Southern Coast districts, all fruit pests should be systematically fought, and the orchard should be kept in a good state of tilth, as, once the wet season starts, there is little chance of cleaning up weeds and rubbish of all kinds, or of cultivating and sweetening the soil.

SOUTHERN AND CENTRAL TABLELANDS.

The earlier kinds of summer fruits, such as cherries, will ripen during the month. See that, if fruit fly makes its appearance, it is systematically fought.

Look out for Codlin Moth, and continue the sprayings with Kedzie's mixture.

Look out carefully for any San José scale that may have escaped the winter spraying, as, if the trees are sprayed whilst the young are hatching out, the bulk of the insects are killed, and little damage is done either to the tree or fruit.

The sulphide of soda spray is one of the best to use now. Keep Woolly Aphis in check, should it make its appearance, using the resin washes; or, if it and San José Scale are both present, use the sulphide of soda spray.

Watch the vineyards carefully for Black Spot and Oidium. Keep the orchard and vineyard well cultivated, so as to retain all the moisture in the soil required for the growth of the tree and development of the fruit. In the warmer parts, irrigate when necessary, following the irrigation by deep and systematic cultivation.

See that grape vines have plenty of foliage to protect the ripening fruit from sun scald, but yet not so dense a foliage as to induce Oidium or Black Spot. Look out for Red Scale on citrus trees, and cyanide to check same. Look out for fruit fly in the early ripening fruits, and gather and destroy all that may be so affected.

Farm and Garden Notes for November.

FIELD.—Under ordinarily favourable conditions, harvesting the wheat and barley crops may now begin. Those who have oats for hay should cut it when the grain has formed, but before it is ripe, for then the plant is in its most nourishing condition. Destroy caterpillars on tobacco plants, and top the latter so as to throw all the strength into the leaves. Keep down the weeds, which will now try to make headway; earth up any growing crops requiring the operation; sow maize, imphée, setaria, Kafir corn, teosinte, sorghum, &c. Plant sweet potatoes, sisal hemp, yams, peanuts, and ginger.

KITCHEN GARDEN.—Why do so few gardeners and farmers grow their own vegetables? This is a question frequently asked by visitors to the farming districts. The reason probably is, that vegetables require a good deal of care and attention, which means also a good deal of time taken from the ordinary farm work. In many cases it pays the farmer better to buy many kinds of vegetables than to grow them himself. The only vegetables grown on many fine farms are cabbages and pumpkins, not to class potatoes under the head. Many people have an idea that European vegetables cannot be grown during the hot summer months, but this is a great fallacy; the Chinese gardeners supply the towns with all kinds of vegetables, except, perhaps, cauliflowers, during the whole of the summer. It is, therefore, clear that, by constant work, plenty of manure, water, and some shade for seedlings, most vegetables can be produced during the hot months from November to March. If your ground has been trenched or deeply dug and well worked, the advantages will be seen during the coming months. It does not pay to work shallow-dug ground. When sowing and planting during this month, give plenty of room between the rows and the plants; otherwise they will be drawn up and worthless, and keep the ground open by constant forking and hoeing. Thin out melon and cucumber plants. It is a good plan to peg down the vines; they will then not be blown about by the wind; they will take root at intervals, and thus help the main stalk. Give plenty of water to tomatoes planted out last month. They should also be mulched. Sow cabbage, French beans, melons, lettuce, radishes, pumpkins, cucumbers, marrows, rosellas, &c.; and transplant for succession in calm, cloudy weather.

FLOWER GARDEN.—Stake any dahlias which may be now above ground, and plant out the bulbs which were stored in a moist place. If the weaker bulbs are reserved, they will come in for autumn planting. Take up all bulbs which have done flowering, and store them in a dry place. Winter-flowering plants will have gone off almost; still, the garden should be in full bloom, and will well repay the trouble bestowed on it, and a little fertiliser given as a top-dressing will assist the plants to bloom and look well for a longer time than if they were neglected. Give weak liquid manure to chrysanthemums, and allow no suckers to grow till the plants have done flowering. Take up narcissi. Do not store them, but plant them at once in new situations. Sow antirrhinum, balsam, zinnia, summer chrysanthemum, calliopsis, and nemophila.

Agriculture.

DEPASTURING WHEAT FIELDS.

A warm and rainy autumn and an early winter are certain to induce a too luxuriant growth of wheat, which is likely to be followed by damage from frost and the exhaustion of the wheat plants long before harvest time. For the purpose of correcting this tendency to overgrowth nothing can equal close cropping by sheep. Next to sheep calves do this work most efficiently, whilst adult cattle and horses, because they pull up so much wheat and otherwise damage the field by "poaching up" the ground, are, for this purpose, least useful of all. A too rampant growth of wheat is often corrected by the timely use of the mowing machine, but whether stock or the machine are employed, it is imperative that the work be undertaken in time. These remarks should, therefore, be noted by young wheatgrowers next season. If the wheat is cut back or eaten back after it has begun to send up seed stalks, it will be found that the plants have not the residuum of strength required to make a second strong growth and an ultimate crop. There are not many wheatfields in Queensland that will not be greatly benefited by allowing sheep to range over them freely during the winter months. These frequent grazings stimulate the tillering impulse of the wheat, cause it to get a deeper and firmer hold of the soil, and force it to conserve its energies ready for the demands of the later stage of growth. Those who have no sheep might borrow a neighbour's flock for use on their wheatfields with great advantage to both borrower and lender.

IMPROVING THE TOBACCO PLANT IN AMERICA.

The Bureau of Plant Industry of the United States Department of Agriculture has mapped out an interesting programme of tobacco experiments for the coming season that should result in much valuable data being secured (says "The Western Tobacco Journal" of 23rd March). The breeding of improved types of tobacco, fertilisers, and rotation experiments, investigations of the curing and fermentation processes, methods of judging and testing tobacco, and the relation of the composition to the burn, aroma, and other characteristics of the leaf, are all included in the season's work. During 1908 experiments will be conducted in Connecticut, New York, Ohio, California, Maryland, Virginia, Kentucky, Tennessee, Florida, Alabama, and Texas.

Chief B. T. Galloway, of the Bureau, has given out the following details of the proposed investigation :—

The work in the Connecticut Valley will be conducted in conjunction with the Connecticut Agricultural Experiment Station, and will consist of the further improvement of the hybrids and strains of the native Connecticut Havana and Broad Leaf varieties by seed selection and breeding. Tests on a commercial basis will be made of the hybrids and strains which have been found to be valuable for cigar wrapper manufacture.

TO IMPROVE SHADE VARIETIES.

Efforts to improve the new varieties adapted for growing under shade will be continued, particularly the Cuban and Sumatra types previously obtained by breeding and seed selection. Selections of seed from plants resistant to this tobacco root rot, made the past season, will be tested in diseased fields the

coming season. Further tests will be made of the value of having vetch and other cover crops for tobacco lands. An acclimated strain of hairy vetch has been secured by breeding, and experiments will be undertaken the coming season to determine the best methods of producing vetch seed on a commercial basis.

Experiments will be continued for the purpose of devising means of controlling the conditions of temperature and humidity in the curing barns in order to avoid damage from pole burn and other causes. The steam steriliser for tobacco seed beds will be further tested in sections of the valley where fungus diseases have developed. The various experiments will be conducted in the East Hartford, Granby, and Suffield districts.

LABORATORY INVESTIGATIONS.

In addition to the field of experiments a laboratory is maintained at headquarters in Washington, where the judging and testing of the tobacco samples are carried out. In this laboratory new and improved methods for the systematic testing and comparison of the different tobaccos are being developed. By these methods reliable data are obtained for further improvements by breeding and selection. Another important feature of these laboratory investigations is the study of the relation of the composition to the important characteristics of the leaf, such as the burn, flavour, aroma, elasticity, colour, grain, and texture. Important results have already been obtained concerning the causes of good and bad burning tobaccos. Investigations on the chemical changes taking place during the fermentation of cigar tobacco are well under way.

TO STUDY FLAVOUR AND AROMA.

A problem intimately associated with these fermentation changes—namely, the nature and origin of the constituents instrumental in imparting the characteristic flavour and aroma—will be carefully studied. Along with the experiments in curing to be conducted in the Connecticut Valley with the object of determining the most favourable conditions of light, temperature, and humidity, careful study will be made of the chemical and physiological changes taking place in the leaf in this process. Another interesting and important problem which will be gone into thoroughly during the coming season concerns the relation of the nicotine content to the quality of the leaf. Finally, it is planned to make a study of the influence of the artificial shade on the important chemical and physical characters of the leaf.

ATTAR OF ROSES.

This delicious perfume, which at one time used to be sold at a guinea a drop, may be obtained as follows:—Gather a quart of rose leaves from fragrant roses after the dew is all off. Do not pick them soon after rain, as they are not so fragrant then. Put a layer of the leaves at the bottom of a wide-mouthed glass bottle, sprinkle with salt, and then cover with a layer of absorbent cotton made wet with pure olive oil, another thick layer of rose leaves, sprinkled with salt, and fill the bottle with alternate layers until the bottle is full. Tie a piece of oil-silk (double) over the top of the bottle; set it where the sun will shine on it all day for two weeks; then uncover and extract the oil from the cotton and rose leaves. It is superior to much of the perfumes which are sold.—“Australian Field.”

Dairying.

THE DAIRY HERD, QUEENSLAND AGRICULTURAL COLLEGE,
GATTON.

RECORD OF COWS FOR MONTH OF SEPTEMBER, 1908.

| Number. | Cow's Name. | Breed. | Date of Calving. | Total Milk. | Average Test, Per cent. | Commercial Butter. | Remarks. |
|---------|----------------|--------------------|------------------|-------------|-------------------------|--------------------|-----------------|
| | | | | Lb. | | Lb. | |
| 1 | Peewee ... | Holstein-Sh'rth'm | 20 May, 1908 | 881 | 3·8 | 34·46 | |
| 2 | Sue ... | Grade Shorthorn | 25 May " | 665 | 4·5 | 33·51 | |
| 3 | Rhoda ... | " " | 28 Mar. " | 582 | 4·2 | 27·37 | |
| 4 | Grace ... | Shorthorn " | 30 May " | 664 | 3·6 | 26·75 | |
| 5 | Hetty ... | Ayrshire-Sh'rth'n | 20 Mar. " | 514 | 4·5 | 26·15 | |
| 6 | Winnie ... | Shorthorn ... | 8 April " | 606 | 3·8 | 25·75 | |
| 7 | Glen ... | " " | 10 Feb. " | 454 | 4·9 | 24·87 | |
| 8 | Remit ... | Grade Holstein ... | 6 Aug. " | 652 | 3·4 | 24·82 | |
| 9 | Lark ... | Ayrshire ... | 6 June " | 541 | 4·0 | 24·25 | With first calf |
| 10 | Carrie ... | Jersey ... | 16 Jan. " | 484 | 4·4 | 23·81 | |
| 11 | Lady Loch... | Ayrshire ... | 14 June " | 527 | 4·0 | 23·6 | With first calf |
| 12 | Nettle ... | Shorthorn ... | 14 May, 1907 | 629 | 3·2 | 22·51 | |
| 13 | Ethel ... | Grade Holstein ... | 3 Sept., 1908 | 503 | 3·9 | 21·93 | |
| 14 | Ruby ... | Ayrshire ... | 21 July " | 513 | 3·8 | 21·8 | |
| 15 | Cocoa ... | Jersey ... | 10 Nov., 1907 | 460 | 4·2 | 21·62 | |
| 16 | Nancy .. | Grade Shorthorn | 7 May, 1908 | 531 | 3·4 | 20·22 | With first calf |
| 17 | Mona ... | Grade Holstein ... | 20 Oct., 1907 | 475 | 3·8 | 20·18 | |
| 18 | Honeycomb | Shorthorn ... | 23 Aug. " | 382 | 4·5 | 19·25 | |
| 19 | Nellie II. ... | " " | 26 Dec. " | 491 | 3·4 | 18·69 | |
| 20 | Patch ... | Grade Shorthorn | 14 Sept. " | 410 | 3·8 | 17·42 | |
| 21 | Cuckoo ... | Jersey ... | 8 Mar., 1908 | 342 | 4·5 | 17·23 | |
| 22 | Lalla ... | Grade Holstein... | 28 July " | 414 | 3·7 | 17·13 | With first calf |
| 23 | Lubra, ... | " Ayrshire | 5 June " | 446 | 3·4 | 16·98 | " " |
| 24 | Madge ... | " Holstein | 6 June " | 419 | 3·6 | 16·88 | " " |
| 25 | Lucy II. ... | " Shorthorn | 17 April " | 396 | 3·4 | 15·95 | " " |
| 26 | Chocolate ... | Shorthorn ... | 5 Mar., 1907 | 353 | 4·0 | 15·81 | |

During the month the herd was frequently changed to different small paddocks, and occasionally allowed to run on old lucerne fields.

WEANING PIGS.

The time of weaning pigs varies from eight to ten weeks old, as a rule ; they are sometimes taken earlier from the mother, and sometimes later, but the time mentioned is the most reasonable. It should depend a good deal on the time they have been feeding, and in the case of any that have been late before they commenced, they should be kept with the mother longer—in the summer time till they are nine weeks old, and in the cold weather till ten weeks old. They should then be good pigs and well able to take care of themselves, and, as a rule, will do as well without the mother as with her. The state and condition of the sow should also, in a measure, be a guide to weaning, as sows that are pulled down very weak have usually done extra well for their pigs, and the latter should be taken away in fairly good time ; on the other hand, if the sow is strong and well, and the pigs are doing well also, they may be left a while longer. Some sows suckle their pigs well until they are six or seven weeks old, and then are useless through the milk drying up, when they are best away ; but such sows should be rejected for breeding, as this fault will become worse the more litters they have. But if a sow has a cold, and gets off her stomach for a day or two, or is unwell through any cause, her supply of milk may be lessened ; she should not be rejected, as her milk will

usually return all right. It is when the sow is hardy and feeding well, and yet appears to have no milk about her, that it is a fault. A profitable sow should have as good a supply of milk as ever, when the pigs are nine to ten weeks old.

There are some sows faulty in other respects. For instance, they may have a large supply of milk, but of such inferior quality that the pigs, although they get sufficient, look poor and bad, and do not get on; these sows should be culled out. Some sows bring a numerous litter, but irregular in size, some being good-sized ones, and others not bigger than rats. It will soon be seen if the sow is at fault by the udder—that is, if the teats the small pigs suck from are light and do not contain much milk. The favourite sow should be the one that brings a good level lot of pigs. The first litter of a sow is nothing to go by with regard to numbers. Good breeders often bring two, three, and four at first, and afterwards turn out well.

The gilt (that is, the breeding sow, so called until it has left its first litter) should be judged by the way she suckles her first lot; if she brings only a few up well, it is all right; but, supposing she has five or six, part good pigs and part very small, she must not be looked upon favourably. If she brings, say, seven—six good level ones and one small one—then she may be set down as fairly promising; but seven or eight good, strong pigs is better.

A gilt's pigs, although they may not be so well grown as an older sow's, should look well on the skin when ready for weaning. A good gilt, if in fresh condition when she farrows and brings up seven or eight pigs or upwards, by the time the pigs are ready to take away, should be pulled well down, or she is not much good for business.

A sow is usually at her best from the second to the fourth or fifth litter; but there are exceptions to this rule. Some sows will bring up the pigs well for about two litters, and then gradually get worse; while others will bring up eight or nine litters without any apparent depreciation in suckling qualities. But it is advisable not to keep them on too long, for several reasons.

As soon as a sow begins to get her pigs small or unsizable, she had better be sold or fatted off, and even though she may do well for seven or eight litters, there is always more danger of an old sow having milk fever or going wrong when farrowing than a young one. Finally, a breeder should keep the sows on, whilst they do well, till they have had five or six litters, and then pass them out.

TO MAKE UP A RATION FOR DAIRY CATTLE.

To begin with, we must have a foundation for the ration, and this may consist of hay, corn-fodder, sorghum, or straw. In the case of cattle or sheep, we take, for each animal, about $2\frac{1}{2}$ per cent. of its live weight in this dry fodder. Now, to this fodder we must add so much of grain or other concentrated food as will bring the total to the required standard of quantity and quality. We will suppose that a dairyman wishes to compound a ration for his cows. The nutritive value of sorghum is 1 to 16, but the requirements of a cow will be met by a much narrower ration—viz., 1 to 5.4. Assuming that the cow weighs 800 lb., we have for the requirements of such a cow organic matter, 19.20 lb., containing protein, 2.0 lb.; carbo-hydrates, 10 lb.; fat, 0.32 lb. She will receive 5 per cent. of her weight in green sorghum daily—40 lb.—the dry matter of which quantity is 9.20 lb. Now to supply the needed protein or albuminoid and carbo-hydrates, 13 lb. of bran are needed, supplying 10.71 lb. of dry matter, 1.63 lb. of protein, 5.73 lb. of carbo-hydrates, and 0.37 lb. of fat, the sorghum furnishing, besides 9.20 lb. of dry matter, 0.32 lb. of protein, 4.90 lb. of carbo-hydrates, and 0.10 lb. of fat. This ration contains as few constituents as possible, and is given because farmers generally are not in a position to make up rations having a number of ingredients.

Following, however, are a number of rations suitable for cows :—

1. Sugarcane tops, 40 lb. ; bran, 9 lb. ; cotton seed meal, 4 lb.
2. Cowpea vines (green), 45 lb. ; maize (ground), 10 lb. ; brewers' grains, 20 lb.
3. Sweet potatoes, 15 lb. ; lucerne hay, 10 lb. ; bran, 10 lb.
4. Maize silage, 40 lb. ; lucerne hay, 10 lb. ; wheat bran, 6 lb. ; maize meal, 3 lb.
5. Fodder maize, 20 lb. ; hay, 6 lb. ; oats, 4 lb. ; shorts, 4 lb. ; oil meal, 2 lb.
6. Maize silage, 50 lb. ; maize stover, 6 lb. ; oats, 6 lb. ; malt sprouts, 4 lb. ; maize meal, 2 lb.
7. Lucerne silage, 30 lb. ; hay, 15 lb. ; wheat bran, 3 lb. ; maize meal, 3 lb. ; cotton seed meal, 2 lb.
8. Panicum hay, 10 lb. ; lucerne hay, 10 lb. ; wheat bran, 6 lb. ; oats, 6 lb.
9. Fodder maize, 20 lb. ; lucerne hay, 10 lb. ; oats, 6 lb. ; oil meal, 3 lb.

The total cost of 1, 2, and 3 is set down at 1s. 1d. respectively, but this is clearly arbitrary, and the cost must be taken for what it is worth, since there are no market prices set upon sugarcane tops and cowpea vines, and the price of maize ranges from 2s. to 4s. 6d. per bushel.

Protein or Albuminoids.—Under these names are included all the nitrogenous substances of the plant. In the animal, they undergo transformation into muscle, hair, horns, the solid matter of the blood and nerves, the curd (caseine) of milk, and the white of egg, the latter being almost pure albuminoid. All the class of leguminous plants, such as clovers, lucerne, cowpeas, &c., are, in plant and seed, rich in the albuminoids. The food that is richest in these has the largest feeding value.

Carbo-hydrates.—This is a term used to denote the sugars, starches, gums, and similar substances in feeding stuffs. Nitrogen free extract is also sometimes used as synonymous with sugars and starches. The carbo-hydrates constitute the greatest portion of the dry substance in feeding stuffs.

WONDERFUL PRICES FOR PIGS.

The "Australian Field" states that the market for pigs in Sydney, early in October, was very high. Messrs. Badgery Bros., Sydney, advised that they sold, amongst other lots, one pig at £7 6s. 6d., one at £6 17s. 6d., one at £6 10s., and others at £6 0s. 6d., £5 11s. 6d., and lower, according to size and quality. Messrs. Badgery Bros. sold, altogether, 163 pigs, which averaged all round, porkers included, £3 5s. 1d.

The breed of pigs which fetched such high prices is not stated.

PINEAPPLE CULTIVATION IN SINGAPORE.

The cultivation of pineapples in Singapore Island has taken larger dimensions than before, large tracts of country formerly occupied by secondary growth being now cleared and covered with pineapples. Great quantities of pines have been also brought into Singapore from the islands around.

The result of this immense crop has been that pineapples have been selling in town for 1 cent apiece, and up country at 5 for 1 cent—that is, about 20 for 1d. The tinning trade is now apparently entirely in Chinese hands. It is satisfactory to see in many of the pineapple fields cocoanuts or rubber being planted, as pineapple culture is by no means good for the land.—"Straits and Federated Malay States Agricultural Bulletin."

The Horse.

CORNS IN HORSES.

A corn, be it remembered, is not a tumour or a growth, it is merely a bruise of the sensitive foot under the horn of the sole. It shows itself by staining the horn red, just as a bruise of the human body shows a staining of the skin above it. To "cut out a corn" with the idea of removing it is simply an ignorant proceeding.

If a corn be slight, all that is necessary is to take off the pressure of the shoe, and this is assisted by removing a thin slice or two of horn at the part. When the injury is very great, matter may be formed under the horn, and, of course, must be let out by removal of the horn over it. Provided there is no reason to believe that matter has formed, a corn—*i.e.*, the bruised and discoloured horn—should not be dug out in the ruthless manner so commonly adopted. Cutting away all the horn of the sole at the heels leaves the wall without any support. When the shoe rests upon the wall it is unable to sustain the weight without yielding, and thus an additional cause of irritation and soreness is manufactured. The excessive paring of corns is the chief reason of the difficulty of getting permanently rid of them.

The simplest device for taking all pressure off a corn is to cut $1\frac{1}{2}$ inch of the inner heel of the shoe. With the three-quarter shoe a horse will soon go sound, and his foot will then resume its healthy state. The saying "once a corn, always a corn," is not true, but it is true that a bruised heel is tender and liable to bruise again, from very slight unevenness of pressure, for at least three months. All that is necessary is care in fitting and abstention from removal of too much horn at the part. Of course, when the degree of lameness is such as to suggest that matter is formed, the horn must be cut away, so as to afford an exit for it, but the majority of corns are detected long before the stage of suppuration has resulted from a bruise.—From "Hunting's Art of Horseshoeing."

SALE OF SUFFOLK HORSES.

Considerable interest has lately been awakened in this State by the introduction of the Suffolk breed of farm horses. It will, therefore, be worth while for those breeders and farmers who think well of this excellent farm breed, to note the following prices which were lately obtained in England, at the annual sale of pedigree Suffolk horses in June last, as recorded in "The Live Stock Journal," under the auspices of the Suffolk Horse Society at Ipswich. This sale was, perhaps, the most successful of the series in respect to prices made and the all-round quality of the animals catalogued. There was a very active demand for fillies and mares, while the geldings sold well. This sale was originally promoted to dispose of the Society's foals, the produce of free nominations to the leading sires for the year distributed amongst small farmers having Suffolk mares practically sound. The prizes for the foals entered were awarded prior to the sale, Mr. D. F. Smith and Mr. H. Overman acting as judges, and Mr. Horace Wolton as steward. First prize was awarded to Mr. Henry Hawes for a typical horse foal by Rendlesham P.S.; a nice filly foal by Redwald, bred by Mr. W. Thomson, second; and a

promising horse foal by Rendlesham Goldsmith, bred by Mr. W. Durrant, third ; while a horse foal by Berners Neptune, bred by Mr. C. B. Cowles, was reserved.

Mr. Alfred Preston, as usual, conducted the auction in conjunction with Mr. Fred Smith, secretary to the society. The number entered for the sale was seventy-four, and the following were some of the prices made :—

MARES AND FOALS.

| | Guineas. |
|---|----------|
| Filly foal, s. Redwald | 25 |
| Horse foal, s. Rendlesham P.S. | 21 |
| Horse foal, s. Rendlesham Goldsmith | 23½ |
| Horse foal, s. Smith's Saturn | 30 |
| Filly foal, s. Toller's Vicar | 32 |
| Horse foal, s. Rendlesham Goldsmith | 23 |
| Ruby, f. 1903, s. Smith's Prince Albert | 39 |
| Golden Belle, f. 1901, s. Pratt's Golden Grain | 27 |
| Filly foal, s. Bentley War Cry | 36½ |
| Smart, f. 1903, s. Sir Ralph Blois' Guardsman | 51 |
| Famous, f. 1900, s. Cook's Border Minstrel | 54 |

MARES AND FILLIES.

| | |
|--|----|
| Puck, f. 1905, s. Smith's Prince Albert | 66 |
| Boulge Dainty, f. 1901, s. Sir Cuthbert Quilter's Prince
Wedgewood | 52 |
| Rendlesham Virginia, f. 1906, s. Smith's Saturn | 70 |
| Rendlesham Depper, f. 1905, s. Rendlesham Toller | 70 |
| Rendlesham Smart, s. Pretyman's Lord John | 48 |
| Peggy, f. 1905, s. Smith's Saturn | 75 |
| Ashmoor Godiva, f. 1906, s. Boulge Monarch | 61 |
| Leader, f. 1898, s. Long's Hurts Upstart | 46 |
| Alberta, f. 1904, s. Smith's Prince Albert | 54 |
| Culpho Bess, f. 1906, s. Boulge Monarch | 41 |
| Dimple, f. 1896, s. Pratt's Eclipse | 33 |

Geldings sold very well, three of them making 52 guineas, 58 guineas, and 48 guineas respectively. One stallion, Boulge Benedick, f. 1906, by Boulge Monarch, made 88 guineas, and another, Boulge Mercury, f. 1906, by Smith's Saturn, 52 guineas.

MEASURING POLO PONIES.

A NOVEL SUGGESTION.

A suggestion has been forwarded by a correspondent of "The Live Stock Journal," London, in regard to the future measuring of polo ponies. There has been a good deal of grumbling on the part of owners who have sometimes had ponies cast, owing to the animals possessing abnormally high withers, and although ponies in size and in every other respect, they could not get

them registered under the official standard. Our ("Live Stock Journal") correspondent suggests that two measurements should be taken, one at the withers and the other at the croup, and if these are added together and divided by two they will give the correct height. The idea being to obtain the correct size of the pony, and not the height at any particular part of the animal, the accompanying figure shows the suggested points of measurement:—

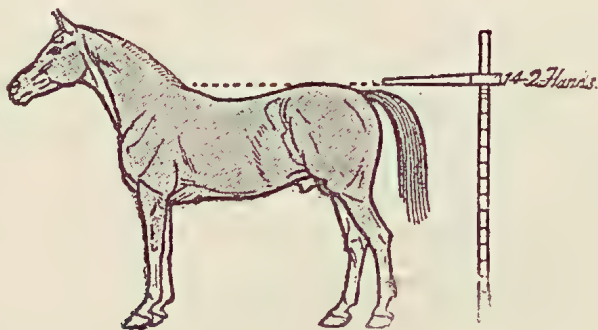

The suggestion has been submitted to a well-known London veterinary surgeon, and he states that croups higher than withers are common. A high-crouped pony measuring 15 hands and 14 hands 2 in. at the withers would pass, but under the "average" measurement would be rejected. Would not this lead to wider dissatisfaction than now obtains, he asks. There is, in his opinion, a much larger class of low-withered, high-crouped animals submitted for measurement than high-withered and low-crouped. Of course, says our correspondent, I hold this gentleman's opinion in high esteem, but surely this last remark wants a lot of swallowing.

A polo player writes us:—"As far as measuring polo ponies for the purposes of the game, I do not think that we are ever likely to improve on the method of measuring now in force. It may not be perfect from a show point of view, but that is not what it was originally intended for."

A gentleman with extensive experience of measurement writes:—"If the plan suggested for measuring the ponies at two points were adopted, and an average measurement arrived at by adding these two together and dividing by two, I estimate that an extraordinary divergence of size would be the practical result. There are a great number of ponies which are now produced for measurement which are much higher at the croup than at the wither. These ponies pass very easily on the wither measurement, but would be rejected upon the dual principle, and would lead to greater rejection than occurs at the present time, and to much more dissatisfaction. . . . It is very difficult to measure at the wither alone quite satisfactorily—not that the actual fact of measuring is difficult, but the difficulty lies in justly placing the pony, and getting it to maintain a fixed position while the measurement is effected. The difficulty would be more than doubled if two measurements were required, as to be correct they must be effected without the pony changing position. The present plan of measurement has its drawbacks, but they are nothing to what would occur if the dual measurement were put into force. The plan of the 'Live Stock Journal' correspondent would be very fair to just one class (a rather small class) of pony, the pony with an abnormally developed wither, but with a low back and croup. It would lead to the rejection of a large number of ponies which now measure satisfactorily at the wither, but which, being very high at the croup, would be cast out when the average is struck between the two measurements."

The Orchard.

EXPORTING MANGOES.

In a short time the Queensland mango crop, which promises to be a very large one, will be ready for harvesting. What is to be done with this fruit? Locally, it is impossible to dispose of the large quantities produced. It remains then to consider whether they can be exported to advantage. The mango, except in an unripe state, is a fruit which does not carry well unless great care is observed in packing. In an article with the caption, "A Queensland Opportunity," "The Fruit World" describes a so-called "Safety Export Fruit Case" for oversea and interstate fruit trade. The inventor of this case claims for it that it will ensure safe transit, will not damage, and cannot be pillaged. It is a basket box, $20\frac{1}{4}$ inches long, $9\frac{1}{4}$ inches wide, and $6\frac{3}{4}$ inches deep. Inside this a set of cardboard pockets is placed, in which the fruit is packed, each individual fruit thus having a ventilated compartment to itself. When the first or bottom layer is thus packed, a flat piece of cardboard is placed on top, making a complete division, then on this is packed another layer of fruit, and the lid nailed on.

The benefit is obvious. Safe transit is absolutely assured, the fruit cannot be damaged or pillaged. Fruit thus packed always brings top prices. This is the box which is recommended for mangoes, though, of course, any and every fruit may be sent in same. The cardboard "filler," which for some time the inventor has been consistently advertising, is a strip of cardboard just a fraction less than the inside measurement of the case. Thus for the basket box just mentioned, the size would be 20 inches by 9 inches by $2\frac{1}{2}$ inches. This is cut at regular distances, and another strip of cardboard also slit horizontally is placed transversely across same. The slits dovetail, and thus by placing these several pieces in position the box is divided into neat and regular compartments.

Now, the box under review would take fruit $3\frac{1}{2}$ inches long by $2\frac{1}{2}$ inches wide; or $3\frac{3}{8}$ inches long by $2\frac{1}{2}$ inches wide; or $3\frac{7}{8}$ inches long by $2\frac{1}{2}$ inches wide. This is called the 8-filler box, and holds approximately 24 lb. of fruit. A basket box of the same length and width, but only 6 inches deep, will take fruit proportionately in three sizes. Thus a grower using two of these remarkable cases would have compartments to suit six distinctly different sizes of fruit.

But that is not all. These are simply "stock" sizes, and if none of these are suitable for the mango, it is the simplest matter in the world to make fillers to suit. It only means cutting the slits in the cardboard at intervals, which fit the mango, and could be done as quickly as it takes you to read these words. Only let the maker know.

Yet once again with fruit such as grapes, it will be immediately seen that these smaller compartments are unsuitable, even regular-sized compartments might be unsuitable. In this instance, the inventor has ingeniously overcome the difficulty by making moveable compartments. For instance, the bunch of grapes would be put in the case, then a strip of veneer wood is placed round same, the ends of each pressing firmly against the two sides of the box, thus making the compartment any size required. This is repeated till the whole box is full. As regards mangoes, this latter method could be adopted with absolute security, and no waste of space.

But the chief difficulty that faces the Queensland grower at this juncture is the fact that these boxes are protected by patent. It would be more convenient to the Queensland grower for these cases to be made in Queensland rather than Melbourne. The cost of making them here is heavy owing to the tariff. But the difficulty is not insuperable by any means. The inventor is willing for the cases to be made in Queensland (where the timber is suitable, plentiful, and cheap), under a royalty. He is willing to supply prices to anyone making application, and considers the cost to the grower, with set of fillers complete (any size) would be only 1s. 2d. As the mango season is just opening, we cannot impress on our Queensland friends too strongly the need of getting in touch with this matter at once.

Apiculture.

BEES AND FRUIT.

From the hon. secretary of the Queensland Bee-keepers' Association we have received the following notes by Mr. D. Jones on the above subject:—

“While visiting a suburban gardener a few days since, complaint was made to me of bees injuring last year's crop of grapes. This matter cropped up some years ago at a meeting of the Brisbane Horticultural Society, when the matter was fully discussed, and a complete refutation given to the charge against our innocent bees.

That they do take advantage of what otherwise would be waste fruit juices is a fact which establishes a sound law in the economy of Nature; for bees will only avail themselves of such fruit juices as appear on fruits already punctured by other insect depredators, such as fruit flies, birds, &c.

In Queensland we often find, in certain seasons, grapes punctured by the fruit fly. This causes an exudation of juice which the alert bee is sure to seize on, with the result that he is charged as being the culprit originating the injury. Entomological study of the structure of the bee's mouth clearly demonstrates his inability to puncture or injure fruit by such a process.

In the case of fruit-fly attack, the bees render practical service in restricting the reproduction of the fly, as, by reason of the thorough manner in which the bees drain the injured grape of its juices, they leave only skin which will not sustain the larvæ, if developed from the egg, originally deposited by the fly

Fruit-growers may well look upon bees as their most valuable allies, particularly in Queensland, where so many new varieties of fruits are being experimented with, dependent, as many are, on prompt and perfect pollinisation, which, without the aid of bees, could not be successfully accomplished.

In America some years since the question was fought out by an expensive lawsuit, when the verdict was emphatically in favour of our bee friends.”

[The question of bees puncturing fruit has been frequently discussed in this Journal, and we showed by conclusive evidence that, as Mr. Jones says, not only does the bee not injure fruit, but that the insect is the greatest friend of the orchardist.—Ed. “Q.A.J.”]

Horticulture

FLOWER GARDENING, No. 10.

By THE EDITOR.

PART II.

ANNUALS.

I have already made mention of a few desirable annuals, and will now devote a few pages to the consideration of others, together with biennials and perennials.

STOCKS.

Stocks, especially the double ones, are amongst the most popular and beautiful of our garden flowers, whether for pot culture or in beds or borders. They are valuable for cut flowers, and remain in bloom for a long time. A bed of stocks has a splendid appearance, and their perfume is delicious.

They are gross feeders, and, therefore, must be grown in good, rich soil, worked deep. Occasional waterings with liquid manure add to the size and beauty of the flowers.

The seed should be sown in pots or boxes, as it is then more under control than if sown in the open ground. When the plants are large enough to transplant, care should be taken to disturb the roots as little as possible.

In planting out stocks, many growers plant only the strongest and throw away the weakest as useless. This should never be done, as the weaker and smaller plants of a batch of seedlings almost invariably produce a larger percentage of double flowers. Seeds of the "Ten-week" varieties may be sown throughout the year, and the "Brompton" or biennial varieties in autumn.

"TEN-WEEK VARIETIES."

Dwarf German.—White and dark crimson. Giant Perfection.—Growth, pyramidal, with long spikes of beautiful large, double flowers. Snowflake.—A very effective wallflower-leaved variety. It is the earliest of the whites, and bears large spikes of snow-white flowers. Princess May.—Produces immense trusses of very large flowers of the finest shape, and of the purest, delicate, light primrose colour. Princess Alice.—Produces large spikes of pure white flowers of great fragrance.

WINTER OR "BROMPTON" VARIETIES.

Empress Elizabeth.—This is a splendid stock, which grows to a height of about 18 in. The plants throw up a very strong main stem, similar to that of a wallflower, and branch out in candelabra form. Both main and side stems are covered with large rose-shaped flowers of the brightest imaginable tint of carmine rose. The whole plant forms a grand pyramidal-shaped bouquet, the effect of which is enhanced by the bright green foliage, which is a feature of this variety. Beauty of Nice.—This is a remarkable variety, of a delicate shade of flesh-pink. It comes into bloom very quickly, quite as early as the ten-week varieties, and sends out numerous side-shoots covered with large and very fragrant flowers of nearly 2 in. across. There is an intermediate variety of these hardy annuals—viz., The East Lothian—a very fine race of stocks, attaining a height of 18 in.

WALLFLOWERS.

These well-known and much-admired hardy flowers will grow in almost any soil and situation, provided they get plenty of sunshine, which is always

possible in Queensland. Sow the seeds in a sheltered situation, in the open, from January to March, and transplant when the plants are strong enough to handle. In sheltered places the plants will rest during the summer, and bloom again during the following autumn and winter.

The double varieties are striking and handsome plants. The single varieties have a delicious perfume, and are hardy biennials.

BALSAMS.

These favourite annuals are so well known that little need be here said about them. They produce rose-like blooms of varied colours in great abundance, and remain in flower for a considerable time. Balsams are suitable for outdoor cultivation, and also make beautiful pot plants, and form striking objects for the decoration of the conservatory or greenhouse.

Many of the balsams obtainable from most nurserymen and seedsmen are notable for their large size, perfect doubleness, and symmetry of form, with the most brilliantly striking and exquisitely delicate and beautiful colouring. A first sowing should be made in August or September, and afterwards sowings up to February. The plants should stand at least 1 ft. apart, and water must be freely supplied in dry weather. They require a rich soil and plenty of sunshine. If the surface soil is mulched to a depth of 2 in., it will keep the ground moist, and also afford nourishment to the plants.

SOME GOOD VARIETIES.

Carnation.—Striped and flaked. Solferino.—Streaked and spotted. Camellia-flowered: Self flowers. Camellia-flowered: Benary's prize, and *Alba perfecta*. Rose-flowered, double.

DIANTHUS.

The dianthus, or, as it is sometimes called, the Chinese pink, adapts itself particularly well to our Queensland climate. It furnishes an abundance of beautiful flowers, and will continue to bloom all the year round almost, if all the old flowers and seed pods are regularly removed, and the flower-stalks which have borne flowers are cut out. When the plants run much to seed, they may be cut down to within 2 or 3 in. of the ground, when they will again bloom in the following year.

If sown during March and April, they will commence flowering early in summer, and continue to bloom freely throughout the autumn and well into the winter.

VARIETIES.

There are numerous beautiful varieties, Heddewiggi having the largest and most beautiful flowers. The improved forms of this section are remarkable for their brilliancy, diversity, and size of flower, and are worthy of special attention.

Hybridus, fl. pl.; *Imperialis*, fl. pl.; Double imperial pink; Mourning Cloak (Double), a charming variety of a very rich purple colour, of the finest double form; Eastern Queen (Single), immense single flowers, beautifully fringed, marbled, and suffused with carmine, rose, mauve, and lilac; Crimson Belle; *Atrosanguinea*, double variety, dark, blood red; *Chinensis* (Indian pink), resembles small carnations.

SWEET WILLIAM.

This is one of the biennials which should not be sown later than November, in order that the plants may become strong for transplanting with the first autumn rains, though the seed may be sown where the plants are to remain.

VARIETIES.

Barbatus produces large trusses of splendid colours. Auricula-eyed Sweet William is a distinct variety, very brilliant and beautiful. Harlequin Sweet William is a very large flowered, single variety dwarf; the flowers are of various shades.

CORNFLOWER.

The blue cornflower, so common in the English fields, is one of the most useful annuals in cultivation. It blooms during winter in profusion, and is most useful for cutting for bouquets in winter and spring. Sow during autumn and spring in boxes or seed beds in light sandy loamy soil. When transplanting, the plants should stand about 18 in. apart. Amongst the cornflowers (*Centaurea*) is included a very interesting family, the Sweet Sultans, which are fine sweet-scented annuals, growing to a height of 1½ to 2 ft.

SOME VARIETIES.

Nana compacta, blue dwarf; *Suaveolens*, yellow; *Chameleon*, yellow and rose; *Cyanus minor alba*, white; *Centaurea moschata* (Sweet Sultan), double, blue, purple and white; *Odorata* "Marguerite," white Sweet Sultan, large sweet-scented flowers; *Emperor William*, blue. The double variety may, to a certain extent, be compared to *Gaillardia Lorenziana*.

COSMOS.

This is an exceedingly beautiful autumn-flowering plant. The flowers are borne profusely in loose clusters, and present a charming appearance, embracing all shades of white, red, mauve, purple, and lavender, some being white, delicately tinted with pink and rose. There are also monstrous white flowers with flecked and serrated edges, and with pink and crimson flowers of the same type, the dark crimson flowers frequently resembling those of a large single dahlia. Plants of this variety are of strong free-branching growth, generally 6 ft. in height; the dense growth of finely-cut, dark-green foliage forms a splendid setting for the star-like flowers. If sown early in the spring, they will commence blooming in autumn, and continue to bloom into the winter. For bouquets and vases they are unsurpassed, lasting a long time in water. The large white variety is most valuable for florists.

SOME VARIETIES.

Cosmos bipinnatus, reddish lilac; *Cosmea bipinnata alba*, white; *C. bipinnata purpurea*, purple; *C. bipinnata rosa*, rose; *C. mammoth*; *Perfection*; *New Giant*; *Red Star*; the *Pearl*; *Klondyke*, yellow; *C. Marguerite*.

CANDYTUFT.

Candytuft is one of the most showy and effective annuals for beds, clumps, or borders. To obtain a heavy mass of bloom, the seed should be sown moderately thick, and, if transplanted, the plants should be set out 6 in. apart. The better plan, however, is to sow liberally and thin out to 6 in. Sow in autumn and spring.

SOME GOOD VARIETIES.

C. Empress and *Carmine* are the finest of all the annual varieties; the former bearing magnificent heads of pure white, and the latter has rich carmine flowers. *White Spiral* is remarkable for its vigorous growth, and large, pure white blooms, forming a very compact spike like that of the *White Rocket*. The fragrant *Candytuft* has gracefully cut foliage; *C. Little Prince* is a handsome new dwarf variety, producing large spikes of large, pure white flowers; *Tom Thumb* is a perfect dwarf cushion of snowy whiteness; *Dwarf Crimson* produces flowers of a rich, glowing colour. Other showy sorts are *Rose Cardinal*, with bright rose-carmine flowers; *Queen of Italy*, rosy white.

The white perennial varieties—*C. gibraltarica* and *Pruiti*—are charming plants, the latter being very useful for pot cultivation.

ANTIRRHINUM.

Under the name of "Snapdragon," this hardy and beautiful perennial is widely known and highly appreciated as an undoubted acquisition to the flower garden. The plant produces long spikes of flowers in endless variety of colour—self colours, stripes, and spots. The blooms are large, of beautiful form, and closely set on the stem. Plants are easily raised from seed, which may be sown in autumn or spring. They will succeed in almost any soil, but will be greatly improved by being grown in rich, light soil, well manured. The Tom Thumb varieties are charming for dwarf beds and edgings.

In the tall varieties, the flower spike runs to a height of 18 in. to 2 ft. The dwarf kinds rarely exceed 9 in.

VARIETIES.

Antirrhinum majus, coral red; *Antirrhinum majus*, Fire King, rose with orange; *Antirrhinum majus*, Romeo, deep rose; Queen Victoria, white; Brilliant, scarlet, golden and white. *Antirrhinum nanum* (dwarf): Queen of the North, pure white; The Bride, pure white; Black Prince, nearly black; Tom Thumb, various colours, very attractive.

CAMPANULA (Canterbury Bells).

This is a genus of exceedingly beautiful perennials, all of which are characterised by the richness of their colours and profusion of bloom, which render them most desirable for the decoration of the garden. The large bells of the pure white variety are especially handsome, and should never be omitted in decorative gardening, as they afford a marked contrast with most other flowers. They can be easily raised from seed. Sow in a frame or box, and plant out later in the border. Sow in autumn or spring.

VARIETIES.

Campanula mirabilis, a new variety with pale blue or lilac flowers; *C. pyramidalis*, white and blue; *C. carpatica*, bright blue; *C. Calycanthema*, with charming saucer-like outer petals, colours various; *C. Persicifolia grandiflora*, Peach-leaved Campanula, white.

DIGITALIS (Foxglove).

Foxglove is a well-known and favourite flower in the Southern States, but is rarely seen in gardens on the coast lands of Queensland, and where it has been grown, although the plants thrive well, yet they did not flower. On the other hand, they do well on the cool table-land at Toowoomba and Warwick, where they are acclimatised. Foxglove is very easy of cultivation, however; so it is worth anyone's while to persevere with it. When in flower it is a very striking and showy plant, and requires plenty of space. It is one of the hardy perennials. Sow in spring and autumn.

VARIETIES.

Digitalis gloxinoides, a superb variety of various colours; Ivory's spotted, beautifully spotted.

ZINNEA.

A class of annuals of great beauty and brilliancy. It is of a branching habit. There is, perhaps, no class of annual flowers which has been so much improved of late years as the double-flowered Zinnias, which may now be considered as almost perfect. They flower throughout the entire summer, and always do best when transplanted. The flowers, which are large and perfectly double, range in colour from white to the most intense scarlet, orange, rose, salmon, purple, &c. Considering their very easy culture, they should be largely grown in every garden. Although very hardy when well established, they are at first tender, and should, therefore, not be sown in the open ground until September, when frosts are not likely to occur. In cold districts they should be sown some weeks later.

When the young plants are 2 or 3 in. high, they may be transplanted to about 18 in. apart, and should be stopped by pinching off the points of the main shoots when about 9 in. high, to induce a compact bushy growth. Zinnias are valuable for their beauty and for the long time they remain in bloom. The numerous varieties form splendid beds or patches, but the flowers being rather coarse in texture should not be too near the eye.

VARIETIES.

Giant, double-striped scarlet and gold ; Zebra, or striped, produces handsome striped double flowers ; Queen Victoria (double giant white), a pure white variety, with flowers measuring 4 in. across ; New Giant (*Grandiflora robusta*) produces perfectly double flowers of immense size—5 to 6 in. across—of the most brilliant and beautiful colours. Other desirable varieties are Tom Thumb, Double Pompon, Dwarf double, &c.

CALLIOPSIS.

This is a very showy class of annuals of almost every shade of yellow, orange, and rich brown, finely marked. It is a very beautiful plant in the garden, and is not at all particular as to soil. It is very effective in beds and borders, remains a long time in bloom, and is valuable for cut flowers. The seed should be sown in autumn and spring, and when the plants are large enough to handle plant them out quite 2 ft. apart.

VARIETIES.

Drummondii, yellow, with crimson centre ; *Bicolor hybrida*, double flowers, yellow and maroon ; *Atropurpurea*, rich, brownish crimson ; *Marmorata*, maroon, crimson splashed ; *Grandiflora*, bright golden yellow ; *Callirhoe pedata*, rosy purple, with white eye ; *Atkinsoni*, yellow and brown.

CLIANTHUS (Sturt's Desert Pea).

The Desert Pea may justly be reckoned amongst the most beautiful of our native flowers. It is a native of the driest portions of Southern and Western Australia. The flowers are brilliant crimson, about 3 in. long, and in the centre there is a large clear black marking. It is a trailing biennial plant, a little difficult to raise ; but it richly repays all trouble spent on its cultivation. The most suitable soil for the Clianthus is a sandy one, but it will also thrive and bloom on ordinary good loam. The best time to sow the seed is from July to the end of September, care being taken to select a sunny situation.

This Desert Pea is known as *Clianthus Dampierii* (Parrot's Beak).

Puniceus, the Glory Pea, is a very handsome perennial shrub, resembling the above, but more erect of habit. It bears a crimson flower.

GAILLARDIA.

The Gaillardias are hardy annuals and biennials, producing beautiful single and double flowers, which are very attractive and showy. They make splendid bedding plants, and are remarkable for the profusion, size, and brilliancy of their flowers. Sow in autumn and spring.

VARIETIES.

G. amblyodon bears fine deep-red flowers ; Josephus, scarlet with yellow bands. *G. grandiflora compacta* forms round bushes 12 to 15 in. high, and bears long-stemmed flowers perfectly upright, colours rich and varied. *G. pieta Lorenziana* ; this new double Gaillardia is a splendid bedding plant, the flowers are double, yellow, and deep crimson. *G. grandiflora maxima kermesina splendens* bears immense flowers, 4 in. across on long, stout stems, with a rich crimson centre, bordered with canary yellow. *G. Lorenz's Perfection* : The quilled petals are produced in such great abundance that they can hardly find space enough for development, thus giving to the flower the shape of a regular full bloom.

Sericulture.

SILKWORMS AND HOW TO REAR THEM, No. 3.

OTHER VARIETIES OF SILKWORMS.

THE TUSSER.

The Tusser (*Antherea mylitta*) is a bi-voltine silkworm—that is to say, it goes through all its metamorphoses twice in the year. These worms are also semi-domesticated, or, in other words, the eggs are hatched indoors, the worms being allowed to feed on the trees by themselves, instead of on leaves plucked for them. In India, the first generation of moths emerge from their cocoons about the beginning of the rainy season (June), from cocoons which have lain dormant since the previous autumn, and lay their eggs; the caterpillars from these eggs complete their cocoons, and the moths emerge about August. The offspring of these moths produce the second crop of cocoons by the end of the rainy season (September), and these cocoons remain dormant throughout the winter, a period of over seven months, and produce moths in the following June, and so the cycle goes on. The worms hatch out about the ninth day. They live and feed from about thirty to forty days, passing through five moults, or changing of the skin, at intervals of from five to eight days, then spin their cocoons, and finally, after twenty-one days from the commencement of spinning the cocoon, the moth cuts out. The caterpillars, at the end of their larvæ existence, are usually about 7 in. in length. The cocoons are very compact in structure, containing a very large amount of a coarse, buff-coloured silk, and of immense size, reaching as much as 2½ in. in length by about 1¼ in. in diameter.

The Tusser worm feeds on a variety of plants, some of which are plentiful in Queensland. The two principal ones are, *Shorea robusta* and *Terminalia tomentosa*; the latter only is found in Queensland. Of the *Terminalias* or allied plants, we have several, especially in the north of the State, all of which are suitable for food. Besides the above, the worm feeds on the *Ziziphus jujuba* (to be found in most gardens) and *Eugenia (syzygium) jambolanum*; *Tecoma grandis*, or allied plants, which are common in Queensland, and known as the Queensland beech and *Lignum vitæ*; *Bombax heptaphyllum*, which is a native; *Cassia lanceolata*, and, indeed, all the *Cassias* which are abundant everywhere here; *Lagerstræmia indica*, a bush found in most gardens; *Carissa corandus*. Of the latter a common native species is found here—viz., *Carissa ovata*; *Ficus Benjamin*, the Weeping Fig, common in the State; Red Cedar; and, lastly, the common castor-oil plant.

When the Tusser worms are allowed to feed on the trees out of doors, constant watch must be kept to keep off birds and insects. If the cocoons which are attached to the branches are required for reeling, they must, of course, be collected, but, if for breeding, they are left on the trees till the moths cut out and the females are fertilised, when they are put into boxes to lay their eggs.

It is possible to rear these worms entirely indoors, if they are copiously watered once a day with a watering can, to imitate the heavy monsoonal rains.

The value of the Tusser cocoons lies in the fact that the pierced cocoons from which the moth has cut out are in great demand for spinning purposes.

Plate XXX. is a very good illustration of the Tusser male and female moths, cocoon, and worm.

THE MUGA.

The Muga (*Antherea assama*), like the Tusser, is a semi-domesticated silkworm, but very much more so, as the eggs are hatched indoors, and the cocoons spun indoors also, the worms only being allowed to feed in the open,

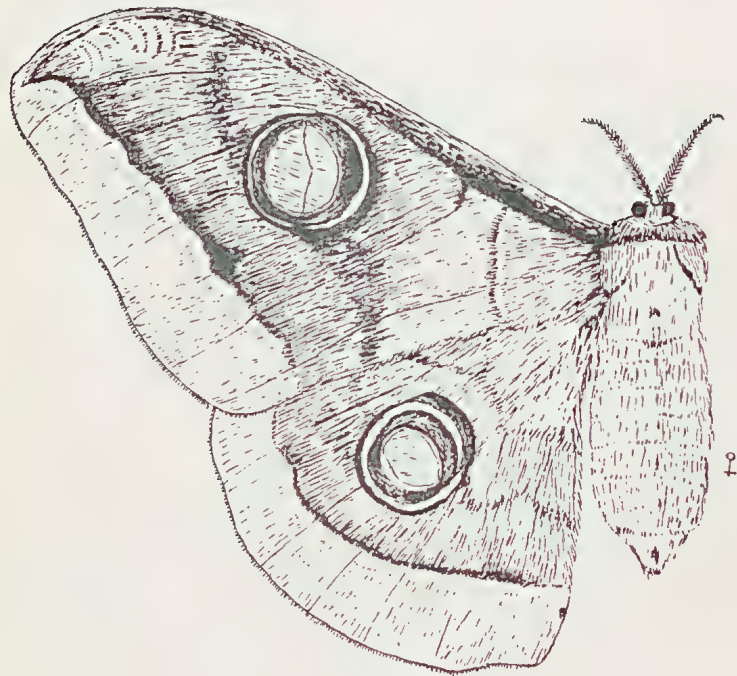

TUSSER MALE AND FEMALE MOTHS, COCOON, AND WORM.

Plate XXXI.



MUGA MALE AND FEMALE MOTHS.
COCOON AND WORM.

Plate XXXII.



ERI MALE AND FEMALE MOTHS.
COCOON AND WORM.

and brought indoors when about to commence spinning. They are then placed on bundles of twigs prepared for the purpose. It is believed that the worm can be reared entirely indoors. The Muga worm moults four times, and takes from 30 to 40 days, according to temperature, to reach the spinning period. The chrysalis stage lasts from 15 to 30 days, a complete generation occupying from 2 to 3 months, according as the weather is warm or cold. The Muga is a multivoltine worm, usually going through five generations during the year. Each female moth produces about 250 eggs. The following description of the Muga silkworm, by Mr. Hugon, will be of interest:—

“On being hatched, the worm is about $\frac{1}{4}$ -in. long; it appears composed of alternate black and yellow rings. The colour alters gradually as it progresses, the males change to sky-blue, then red with a bright gold-coloured ring round each. The full-grown worm measures, when extended, about 5 in. in length, and is about as thick as the fore-finger. Its colour is green. The cocoon is nearly 3 in. in length, by about 1 in. in diameter, of a golden-yellow colour. The silk is much more valuable than that of the Tusser, and there is a considerable demand for it in Europe.”

The Muga silkworm's favourite diet and chief food consist of the leaves of *Machilus odoratissima*, which is not found in Queensland, although there are several allied plants known as Laurinæ which would doubtless do as well. *Tetranthera monopetala* is one of these; another is *Sarcostemma brevistigma*, found all over Queensland, growing amongst the mangroves or near the beach; the common name of this is “The Caustic Vine.” *Ziziphus jujuba*, *Eugenia jambolanum*, and the castor-oil plant are also used.

The Muga cocoon is reeled, and can be also spun. The worms are raised in a similar manner as that described under “Tusser.”

Plate XXXI. illustrates the Muga male and female moths, cocoon, and worm.

THE ERI.

The Eri (*Attacus ricini*) is a multivoltine silkworm, reared entirely indoors in a similar manner to the ordinary mulberry worm.

Although as many as eight generations can be gone through in a year, not more than five are usually reared. The female moth lays about 200 eggs, which, in favourable weather, hatch out in about 10 days from the date of being laid, and a month from hatching sees the worm full-grown—during this period, passing through four moults—when it commences spinning its cocoon. The moth emerges in from about 2 weeks to 1 month, according to temperature.

The worm on hatching out is about $\frac{1}{4}$ -in. in length, and appears nearly black. As the worm grows, the colour changes with each moult, ending in a dirty white or dark green. The full-grown worm is $3\frac{1}{2}$ in. long. The cocoon is $1\frac{1}{2}$ in. long by $\frac{3}{4}$ -in. in diameter, of a white colour, although sometimes worms of the same brood, fed on the same food, will turn out brownish-red cocoons. The cocoon is somewhat loose in texture, but the silk is very strong.

The principal food of the Eri is the common castor-oil plant. It also feeds on the leaves of the Umbrella Tree of North Queensland, on the Physic Nut plant, and the *Ziziphus jujuba*.

A well-developed castor-oil plant will, after a season's growth, yield 14 lb. of leaves, so that an acre containing 2,732 plants will supply 38,300 lb. of leaves, sufficient to feed 600,000 silkworms in a season.

The value of Eri cocoons has risen considerably, and the demand in England is greater than the supply. The cocoon is worth 3s. per lb. dried, and, what is of great importance, no exception is taken to pierced cocoons—indeed, these latter are preferred, as there is no need to choke the chrysalis as in the case of the mulberry silkworm.

Plate XXXII. is a good illustration of the Eri male and female moths, cocoon, and worm.

STATISTICS.

As stated, one acre of castor-oil plants will support 600,000 Eri silk-worms during the year—that is, six broods of 100,000 each. Allowing for deaths, &c., these will produce 450,000 cocoons. One thousand six hundred Eri cocoons go to the lb.; therefore, 1 acre of land will produce 300 lb., which, at 3s. per lb., amounts to £45. Roughly speaking, to put 1 acre under castor-oil, and to rear the worms, should not cost more than £15, leaving a net profit of £30 per acre.

The accompanying diagrams illustrate the method of making the “tavelette.” It was accidentally omitted from our last article dealing with the reeling of silk:—

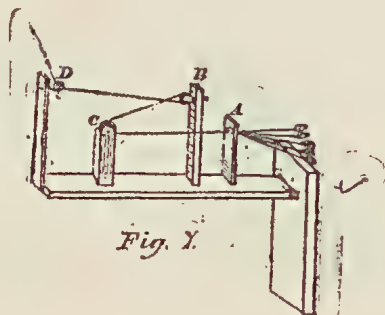
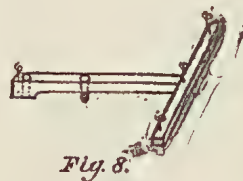
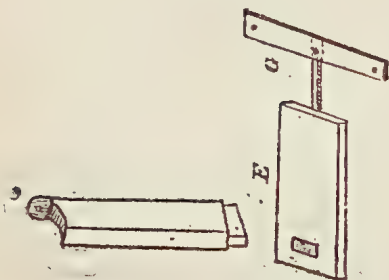
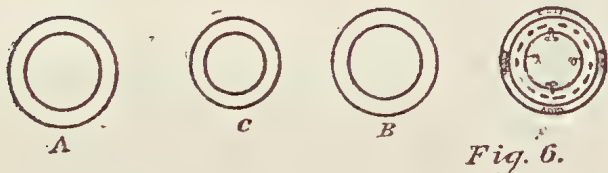
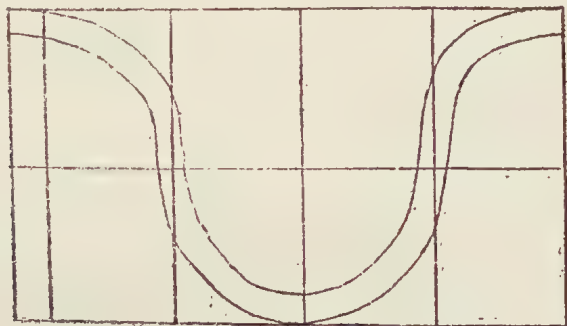

Tropical Industries.

CULTIVATION OF SISAL HEMP IN GERMAN EAST AFRICA.

(From the Bulletin of Miscellaneous Information, Royal Botanic Gardens, Kew.)

ENCOURAGEMENT TO QUEENSLAND PLANTERS.

The following article published by the "Kew Bulletin" should give great encouragement to sisal-growers in this State. It will be seen that cutting can only be carried on in East Africa for two or three years before the plant puts forth its "pole," so that, in order to maintain a good yield from 1,000,000 plants, 500,000 new plants must be put in between the old ones. Here Queensland has, from the experience gained by planters who have already machinery installed, a great advantage, as plants have not been known to pole here before the expiration of from 5 to 7 years, and, had the leaves been cut at maturity, probably 2 or 3 more years would have been added to the lives of the plants. In 6 years, the exports of fibre from one plantation—Kikogwe—rose from 7½ tons, worth £155 (£22 per ton), to 986 tons, worth £32,000 (£32 9s. per ton).

The following article on the cultivation of sisal hemp in German East Africa, which is an abstract from Dr. Stuhlmann's paper in "Der Pflanzer," Nos. 15 and 16, September, 1907, pp. 229-243, appeared in the "East African Standard" for 16th May, 1908:—

In 1893 the German East Africa Company in East Usambara ordered 1,000 sisal plants from Florida, but only 62 survived the journey. These were carefully tended in the plantation at Kikogwe, and new plants were propagated from them, so that in 1898 the number had increased to 63,000. In 1899 machinery was introduced for extracting the fibre. By the beginning of January, 1900, there were no less than 150,000 plants established, of which 4,000 were more than 3 years old and were ready for cutting. After it had been ascertained, by means of small samples sent for valuation, that the fibre was of good quality, the first consignment was made in 1900. The following are the amounts and values of the exports of sisal hemp from Kikogwe during the years 1900 to 1906:—

| Year. | Amount. | Value. | Year. | Amount. | Value. |
|-------------|---------|--------|-------------|---------|--------|
| | Tons. | £ | | Tons. | £ |
| 1900 | 7½ | 155 | 1904 | 624 | 18,300 |
| 1901 | 45 | 1,300 | 1905 | 887 | 27,000 |
| 1902 | 177 | 5,445 | 1906 | 986 | 32,000 |
| 1903 | 347 | 9,860 | | | |

In 1894, out of a total of 1,800,000 plants, as many as 1,300,000 were ripe for cutting, and from these were obtained 624 tons of fibre; hence the yield per plant was about 17 oz. The same number of plants were cut in 1905, and yielded 887 tons, or about 25 oz. per plant. In 1906 there were 1,600,000 plants fit to be cut, and these produced 986 tons of fibre, or about 22 oz. per plant. From these figures it appears probable that each plant, after reaching the age at which leaves can be cut from it, will give an annual yield of 17 to 23 oz. of fibre, and that in a carefully-cultivated plantation about two-thirds of the total number of plants will be ready for cutting if replanting is carried out where necessary. From 1,000,000 plants, of which

666,000 can be cut annually, a crop of 333 to 433 tons of fibre may be anticipated. In order, however, that this yield may be maintained, it is necessary that 500,000 new plants should be inserted between the old ones, as cutting can only be carried on for 2 or 3 years in German East Africa before the plant puts forth its inflorescence, or "pole." It is calculated that if 800 plants are planted per acre an annual crop of 900 to 1,200 lb. per acre should be obtained. The results obtained at Kikogwe lend support to this estimate.

The following table gives interesting particulars as to the approximate number of Agave plants in the different districts of German East Africa at the beginning of 1907, and the proportion which were ready for cutting:—

| District. | No. of Plantations. | No. of Plants. | No. of Plants ready for Cutting. | Total Area Planted. | Area occupied by Plants ready for Cutting. |
|-------------------|---------------------|----------------|----------------------------------|---------------------|--|
| | | | | Acre. | Acre. |
| Tanga | 13 | 10,305,600 | 2,168,000 | 14,250 | 3,190 |
| Wilhemstal | 3 | 810,160 | ... | 560 | ... |
| Pangani | 2 | 3,330,000 | 2,200,000 | 5,000 | 3,500 |
| Lindi | 5 | 1,127,000 | 110,000 | 1,330 | 137 |
| Total | 23 | 15,572,760 | 4,478,000 | 21,140 | 6,827 |

In the Tanga district the low proportion of the plants which were ready for cutting is explained by the fact that at the time of making the estimate many of the recent plantings had not reached maturity.

The four districts mentioned above require a total number of daily workers of 8,500, or, allowing for absence from illness or other cause, a staff of at least 11,300 people. The workers are paid on the average 40 hellers per day.

The machine employed for sisal hemp extraction in the larger undertakings in German East Africa is one which is used to some extent in Yucatan, Mexico, and is known as the "Molla" machine.

It costs about £650, is capable of treating from 85,000 to 120,000 leaves in ten hours, and needs about 48-h.p. to drive it. The bundles of leaves as brought in from the plantation are placed by one or two workers on a travelling lattice, which carries them to a table in front of the machine. Four men are then required to open the bundles and lay the leaves on the conveyer, which introduces them to two raspadors arranged at right angles to one another, where they are cleaned, one-half of the leaf being stripped at a time. The fibre on leaving the machine slides down on a wooden frame, and is then subjected to washing, women being employed for this work. In order to keep the machines sufficiently employed a plantation of at least 600,000 plants is requisite, which, allowing a space of 40 in. by 100 in. (about 3½ ft. by 8½ ft.) for each plant, will cover an area of about 310 acres. Disadvantages possessed by this machine are the difficulty of replacing damaged parts, and the lack of durability of the bronze coating with which certain portions of the machine are provided.

The following are the approximate quantities and value of the sisal hemp exported from German East Africa since 1902:—

| Year. | Quantity. | Value. | Year. | Quantity. | Value. | Per Ton. |
|-------------|-----------|--------|-------------|-----------|--------|----------|
| | | £ | | | £ | £ s. |
| 1903 | 422 | 16,000 | 1905 | 1,140 | 43,900 | 38 10 |
| 1904 | 765 | 28,300 | 1906 | 1,836 | 66,900 | 36 8 |

During the first half of 1907, the exports from Tanga and Pangani amounted to about 1,321 tons, of a value of £50,600, or £38 6s. per ton.

These figures must be taken as absolutely correct, seeing that they are published by the authority of the Director of the Botanic Gardens, Kew, and must have been fully verified before publication.

SISAL FIBRE DECORTICATOR.

Amongst the numerous machines devised for the cheap extraction of aloe and other fibres, there are few which will enable the white grower in Queensland to compete with the cheap black labour in other countries. What is wanted by the grower of from 50 to 100 acres of sisal or sansivieria is a machine costing from £50 to £75 landed here, which will, with a minimum of labour and engine power, turn out from 750 to 1,000 lb. of clean fibre in a day of 8 hours. No such machine has yet been placed on the market. Certainly the decorticator designated as A1 by Mr. E. Lehmann, a Manchester engineer, comes closest to the requirements of the small planter. This machine costs £65 in England, and is said to be equal to turning out 750 lb. of clean fibre per day of 12 hours. But the Queensland working man's day comprises only 8 hours, hence the day's work, if all runs smoothly, only results in a turn-out of about 5 cwt. per day.

We now find another machine adapted to both sisal and sansivieria leaves, in the market in Rhodesia. The name of the maker is not given, but it is supplied by The Eastern Landing, Clearing, and Forwarding Co., Ltd., 28 Strand road, Calcutta, India. The price is, including packing and delivery f.o.b. export steamer, £28. The weight of the machine when packed is from 12 to 15 cwt., which can be split up into 3 handy packages, totalling 40 cub. ft., or 1 ton measurement.

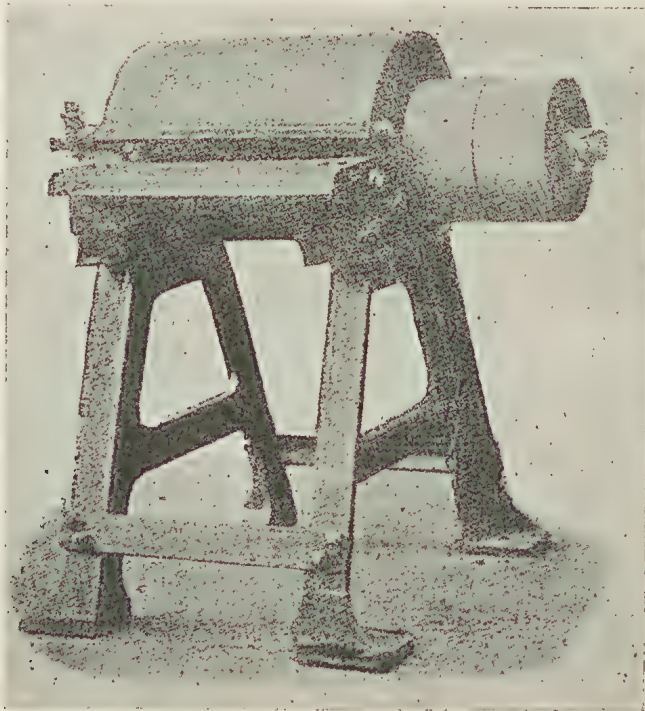

The following particulars are given of this decorticator:—

Length at base, 3 ft. 2 in.; breadth, 2 ft. 8 in.; height, 3 ft. 10 in. The feet have holes bored, making it suitable for bolting on to sleepers, thus rendering the machine easily portable, and doing away with the necessity of expensive building foundations.

The total gross weight of machine fitted complete is 12 cwt.

The machine is capable of receiving two leaves at a time, and, with two men feeding, will deal with 8,600 lb. of leaves (*Agave rigida sisalana*) per diem, thus giving an out-turn of 300 lb. dry fibre.

There would also be a quantity of fibre recoverable from the waste, which has a considerable market value. It is advisable, in order to obtain the best results, to put the leaves through the decorticator as soon as possible after they are cut, and before they become dry and weedy, as in this state the decortication is somewhat difficult.

The machine requires $\frac{3}{4}$ nominal horse power, and should be driven at 700 to 800 revolutions per minute.

The machine is fitted, if desired, with a sprayer which ensures a continuous run of water on the leaves during the process of decortication.

SISAL (MAGUEY) IN HAWAII.

The following instructive account of the cultivation of the sisal plant, and the production of the fibre in Hawaii, forms the subject of an article in the "Philippine Agricultural Review," by the editor of that journal. It bears out much of what we have stated concerning the cultivation of the plant. Singularly enough, when the fall in prices for the fibre took place in Yucatan in 1907, the price obtained in Victoria for Queensland fibre was £32 per ton. The article in question is as follows:—

There is much land suitable for the cultivation of sisal on all of the islands of the group. Sisal is not in the stricter sense a cultivated plant, practically no cultivation being given after the plantation has been established, other than to clear out glue, lantana, and other weedy undergrowth. Sisal may be cultivated on any land not too thickly grassed, from sea level to an elevation of 2,000 ft. The controlling factor is rainfall and not elevation above sea level. While this crop has been cultivated in large areas in extremely barren and rainless country, such a location should not be chosen if cheap lands in a moderately wet district are available. Better results through more rapid growth and maturity are obtainable in locations where the rainfall ranges from 20 to 50 in. per annum than where it amounts to less than 20 in.

Sisal is propagated from suckers or offshoots which appear at the base of the mature plants; and from pole bulbs, which follow the flowers instead of the seeds. The sisal plant almost never produces true seed pods, and even when these are produced the seed is seldom fertile. If suckers are used they may be transplanted at once to the field, but pole bulbs must be planted a year in fertile land to force their growth. While pole bulbs are sometimes set out in regular nursery rows, far enough apart to cultivate between them, a better style of plant for transplanting is secured by setting the bulbs in a compact mass, the individual bulbs not more than 2 to 4 in. apart. This makes a close, compact plant, easier to transport and handle than are the suckers or pole plants which have been set in nursery rows at wider distances. The object of nursery planting is to force growth in the early stages, shorten the period between planting and maturity, and add greater uniformity to the field.

Before planting it is best to clear the land of brush and weeds. Roadways should be laid out on such a contour that portable tracks may later be built through the plantation to facilitate the harvesting of the crop.

The plants are set in the field in regular rows from 7 to 9 ft. apart and from 4 to 8 ft. in the row, at the rate of from 800 to 1,100 plants per acre. It is a disputed question as to the amount of cultivation that can be profitably given, as well as the amount of preparation necessary before planting. Practice varies from picking up a circle 3 ft. or more in diameter around the young plant, to no cultivation other than a hole made with a single blow of a mattock, loosening just enough dirt to pack the plant in position until it sends out roots.

Harvesting begins at the end of the third year after the nursery plants or suckers have been set in the field. The leaves are considered ripe for harvest when they have fallen from their rigid, erect position to a looser, horizontal one. From ten to twenty of the lower leaves are cut from each plant. In 6 months another crop is cut, and so on until all the leaves have been taken. The leaves are bundled and hauled to the mill on carts or cars. The location of the mill should be decided upon before any planting is undertaken, being located either at the lowest point of the land or convenient to shipping facilities. The fibre is extracted from the leaves by high-power modern machinery especially devised for the purpose. Two systems of milling are in use. One type of machinery requires a supply of water which is trickled over the leaves while the fibre is being extracted. The other type requires no additional water supply other than the abundant juices of the leaf itself. As soon as the fibre is extracted it is hung on lines out of doors where the sunshine can dry and bleach it. When well dried and bleached it is made up into firm bales of 400 to 500 lb., and is ready for market.

In Hawaii the average life of the sisal plant is about 9 years.

At least two crops can be harvested every year beginning with the third. As soon as the plant has thrown up its flowering pole it dies; the plant is then uprooted, and another nursery plant set in its place.

Hawaiian-grown sisal is pronounced by fibre experts to be of the best quality. It is superior to that produced in Yucatan, its only direct competitor being a limited supply which comes from German East Africa. The yield of fibre varies according to the number of plants set to the acre, and their size and vigour, but may be taken as averaging about 500 lb. to the acre per annum, or about 3,000 lb. per acre for the full life period of the crop. The fibre composes about 4 per cent. of the weight of the leaf. In milling, the larger portion of the short fibres at the base of the leaf go into the waste. The average recovery of fibre in milling does not exceed $2\frac{1}{2}$ per cent. of the total weight of the leaf, and sometimes, through carelessness or badly-adjusted machinery, not more than one-half of this amount.

The profitable disposition of the waste is somewhat of a problem. In Yucatan the waste is fed to cattle, a portion of the wages of the plantation labourers being paid in fresh meat. Every plantation in Yucatan runs a large herd of cattle. The milling takes place in the daytime, and the cattle are turned in to the mill yard at night, cleaning up thoroughly the pulp and waste fibre produced by the machines during the day. Cattle eat the sisal pulp readily, and thrive upon it. In Hawaii the only use thus far made of sisal waste has been to dry it, clean out the short fibres, and curl them for use in the manufacture of mattresses. The sisal waste, or at least that part of it consisting of the short and broken fibres, is worth from 1 to $1\frac{1}{2}$ cents per lb. as paper stock. The size of the plantation and the amount of waste will to some extent govern the methods of its disposal.

Fibre-extracting machinery is not expensive. The total cost of buildings and machinery for a sisal plantation of 500 acres should not exceed 10,000 dollars (£2,000). The outlook for this crop is a very good one. The total world's crop of sisal is less than 400,000 tons, and the demand for sisal has been growing more rapidly than for Manila or other competing fibres. The prices f.o.b. Honolulu during the last 5 years have ranged from 6 to 8 cents (3d. to 4d.) per lb., although during the panic in the latter part of 1907 the

price fell to $4\frac{1}{4}$ cents ($2\frac{1}{8}$ d.), bringing financial ruin to practically the whole Mexican Province of Yucatan. At this writing (June, 1908) prices have recovered to about $6\frac{1}{2}$ cents ($3\frac{1}{4}$ d.), equal to £30 6s. 8d. per ton, and the trend seems to be upward. Those who have studied the fibre market of the world believe that both demand and prices are bound to increase.

The sisal crop is an attractive one for individuals or corporations owning large areas of cheap lands suitable only for grazing. There is practically no cost of cultivation other than the most meagre preparation of the land, the purchase of plants, setting them in the field, the harvesting of the leaf, and the shipping of the fibre. The industry is one which does not require the continuous employment of large numbers of labourers. It may be undertaken at a comparatively small capitalisation per acre, and may be carried on without the large monthly expenditures which must be incurred in the cultivation of more remunerative crops on better land. There is much land suitable for the cultivation of sisal on every one of the islands of the Hawaiian group.

MANUFACTURE OF RAMIE.

In continuation of an article on the Ramie Industry, "The Pastoralists' Review" says:—

Ramie can be cultivated in all soils and climates such as before named, and it thrives best in the shade. It is a hardy perennial—that is, its roots do not perish annually like those of flax, but, on the contrary, a single sowing of the plant with slight care will last for many years. The plant is propagated by means of seed roots and suckers, and it grows to a height of about 6 ft., yielding from four to six annual cuttings of fibre-yielding stems. It has been known to grow 8 ft. in height. The stems of the plant turn brown in colour when the fibre has matured; they must then be cut off about 2 in. above the ground. The cost of ramie cultivation has been estimated by various authorities to be about £4 per acre, and, under the best systems of growing, a yield of 1 ton of dry fibre per acre per annum may be obtained. The first year's crop of stems will be of little value for textile manufacturing purposes, but the second year's will be of good quality and readily saleable. It improves annually thereafter in yield and quality. Its fibre yield per acre is in excess of that of flax, and, as a fibre, is rather lighter; a further marked advantage in connection with its use for sailcloth manufacture is that vessels with ramie canvas can carry a greater amount of canvas without danger than when flax and cotton are used in their weaving. This circumstance caused Sir Thomas Lipton, in racing his yacht "The Defender" for the American Cup some few years ago, to have the sails made from ramie, and it is also advantageous in tent canvas and fishing line and net making.

The fibre yield of the plant and its quality is improved by suitable manuring. Liquid manures are the best to use, farm manure being used only as a winter covering. From a comparatively small number of plants a fairly extensive plantation can quickly be created. The roots should be set in furrows after the land has been well manured; the ground can then be pressed down, and, if the rainfall is good, they will make a rapid growth. The stems come to maturity in about 6 months, after that one line of plants in each two may be taken away, their roots divided, and these reset. The leaves when stripped from the stems are a good fertiliser for the ground. For the purpose of stripping the bark from the stems and cleaning the fibre a machine has recently been invented by M. Faure, a French engineer, of Limoges, France. This machine may be said to be at once both effective and economical. It represents the outcome of many years' close study of the question of the fibre's successful decortication, and it was some little time ago tested on green ramie stems grown on land owned by Mr. Faure at Limoges, in the presence of several gentlemen interested in ramie growing and spinning,

who expressed themselves well satisfied with the manner in which it did its work and its product. Worked by two men, it is capable of cleaning 32 cwt. of green stems in a day of 10 hours; the article produced is a clean uncrushed and unbroken fibre equal to the hand-cleaned ramie or China grass of China, the entire removal of the bark and all woody portions of the stem is effected, together with the major portion of the gums and resins, at a cost of £3 12s. per ton for dry fibre produced. The cost of each machine is £40. It is strongly built, so as to stand the wear and tear of plantation use. The cleaning capacity of the machine, it was urged, is not large, but M. Faure, however, is devoting his efforts to improve upon it in this respect, which he is confident he will be able to do. If the decortication of the stems is carried out daily, however, as they mature, instead of this being left to be done in the course of a couple of weeks' time, at the end of four seasonal cuttings one of these machines will be found capable of cleaning the fibre production of many acres of land, and when a number of these are in use an endless travelling apron passing from one machine to the other removes the refuse and keeps the neighbourhood of the machines free from this.

Another method of preparing the fibre for the market in the form of the bark strips, or, as they are called, "ramie ribbons," is to place the stems in wooden boxes about 6 ft. long by 2 ft. wide and 2 ft. deep, and closing the lid inject steam into the boxes by means of a steam producer. When they are opened and the fibre is removed the bark will be found to readily separate from the stem. These boxes can be moved from place to place on ramie plantations followed by small portable boilers. After machine decortication or this steaming process, the fibre is extracted or degummed, and then in the form of a fine white silky material, which is called "filasse," it is ready to be taken into the mill for the purposes of preparing, combing, spinning, and weaving. It is for this decorticated fibre equal to China grass and for ramie ribbons that a demand exists on the part of ramie spinners for use in place of the more expensive China grass imported from China. The price obtainable for "Faure decorticated fibre" is about £23 per ton, or slightly over; for well-cultivated ramie ribbons about £10 per ton, or slightly over, may be obtained at port of shipment, both of which prices will show a good profit to the planter. Great care must, however, be exercised after stripping the ribbons from the stems to dry them thoroughly, and they must not be baled in a damp or wet condition; if this is done fermentation will set in, and damage the strength of the fibre on its voyage to manufacturing centres; the ribbons should be spread on wire nettings and exposed in the sun until thoroughly dry, being removed indoors at night to avoid the damp and dews. Bales for export should be from 5 to 10 cwt.

The fibrous bark can also be removed from the stems by making a slit in the centre of the stem with a small knife, inserting the fingers and stripping the fibre from the stems. This method of doing the work is well understood by the Chinese, as well as is the rapid hand-cleaning of the fibre. It is the method for small native or other agriculturists who might grow the fibre as a garden or small field crop. Raw supplies are imported into Europe through the medium of London, Antwerp, and Hamburg produce broking firms, and into the United States through New York.

Ramie fibre when well extracted or degummed is in the "filasse" condition equal in regard to quality and wear to Belgian flax costing about £60 per ton. Each ton of ramie ribbons degummed yields half a ton of this white fibre or "filasse," and each ton of China grass and machine-decorticated fibre 70 per cent. on net weight treated. On all plantations for ramie growing pathways require to be left, as in the case of tobacco, cotton, indigo, ginger, and other estates, to permit of labourers passing about the fields and cutting the stems, and roadways should be provided on large growing plantations for the passage of vehicles; a central road when made can be used to take the crop as gathered to the buildings where it has to be decorticated and stored. Each native should carry a hand-basket in which to deposit the stems when

cut, and when his basket is full he can place it on the cart to take it to the stores, or on a light tramway which could be run up and down the estate at regular intervals.

Rice and jute lands are not suitable for ramie growing, as in permanent dampness the roots of the plants rot away, nor can it be successfully cultivated for fibre purposes in strong compact soils, even if they are easily accessible to irrigation. The plant has been known to stand well the severest winters and prolonged droughts, but in the case of the latter its external growth will languish. The cheapest method of producing "filasse" is to carry out not only the process of decortication, but that of degumming also, on the lands where the fibre is grown by means of native labour, which is cheaper than that which has to be employed when this is done in manufacturing centres, and a further considerable saving is effected in this way by shipment to these only of the extracted fibre in a condition ready to be passed through the processes of preparing, combing, and spinning in the mills, instead of in the undegummed state, when freight has to be paid on about 50 per cent. of bark, gum, and woody matter which has no value as a commercial product, and in this way "filasse" can be produced at about £20 per ton. Ramie is a very much superior textile to either the higher grades of cotton or jute, and, although it can be obtained in this way at a price which is very low, it commands a better figure on the market than these textiles.

Great difficulties were experienced in the early efforts to work the fibre, on account of the fact that it is not so elastic as cotton or flax, and to cover this defect the fibre is submitted to a special treatment in its degumming in all the best processes in use to-day, which imparts ductility to it, and causes it to spin with ease and free from undue breakages, tangles, or knots, and its peculiarities are governed when it is being woven into the finer descriptions of fabrics into which it is now being manufactured, such as dress materials, art linens, and tapestries, by special motions and modifications in the looms employed. For the general run of cloths the yarns can be woven on any loom. In combing preparatory to spinning, its yield of long fibre, which is the most valuable for textile manufacturing purposes, compares favourably with that obtained from flax; from 70 to 81 per cent. of long and medium length fibre is obtained, the short fibre or waste thus averaging from 30 per cent. down to 19 per cent. This is manufactured into cheap blankets and shoddy goods, which have a profitable sale. In dyeing and printing the fibre, the very best results in regard to uniformity and fastness of colours are to be had as cheaply as in the dyeing and printing of other textiles, either when the yarns are woven into pure ramie cloths or mixed with cotton, flax, worsted, or silk warp yarns; special dyes are, however, necessary in dyeing the fibre when it is woven in combination with silk, the one being a vegetable and the other an animal product.

The fibres of ramie do not show as great a disposition to adhere together as those of cotton, but rather a tendency each to go its own way, and special means, which it has taken many years to devise, have had to be made use of in spinning the fibre successfully to deal with this peculiarity as well as the difficulty of passing filaments of such a great diversity of lengths as from 3 to 14 and even 16 in. simultaneously through the processes of drawing prior to spinning. The overcoming of these obstacles within recent years, however, has led to an increase in the spinning and weaving of ramie textiles in Europe and the United States, and when well degummed, as in the chief extraction factories, the material is found free from brittleness, harshness, and hairiness, producing round, smooth, even yarn and well-woven fabrics. The spinning of ramie yarns is carried on in mills in Berlin and in Lyons, and other districts in France, Rochdale in Lancashire, Dundee in Scotland, and other places by firms who purchase the degummed "filasse" from extraction mills, and who make its spinning their exclusive trade. In many other districts in England, on the Continent, and in America it is spun more or less by flax, worsted, and silk spinners, who purchase the material either in the "filasse" state from

extractors or in the form of a skein, or, as it is called, a "sliyer." There have only been two liquidations of ramie mills within the last few years, caused mainly by faulty processes.

There are two varieties of the ramie plant, known botanically as *Boehmeria nivea* and *Boehmeria tenacissima*: the former is the temperate zone variety, and the latter the equatorial plant. *Boehmeria nivea* is distinguishable from *Boehmeria tenacissima* by reason of the backs of its leaves being silvery white in colour, those of the latter species being green. The fibre of the variety of the *Boehmeria nivea* is rather finer than that of the *Boehmeria tenacissima*, and is capable of being spun into higher counts of yarn, but it is not quite as strong as the fibre of the *Boehmeria tenacissima*. The highest counts or finer classes of ramie yarns are spun in London, England, some as high as 180's silk counts, the French and German mills spinning up to about No. 80's in metric counts. The cloths are silkier, wear longer, and are cheaper than such artificial silks as Chardonnets, Viscose, Bronnerts, and other wood-pulp silks so extensively manufactured and exported from France and other Continental countries, also the various classes of mercerised goods.

The degumming of the fibre is carried out in extracting factories in high-pressure bleaching kiers; when this is done on plantations, special digesters are used. The machinery for preparing and combing ramie cheaply and well is made by several English and Continental machinists, and can be purchased on the market in the ordinary way. The plant necessary for its degumming or extracting, while not costly, is of a special character, and its manufacture is carried on by a few firms who make a specialty of the same.

The perfecting of the methods of ramie manufacture from its decortication to the weaving of the yarns which has taken place within recent times, the erection of new extraction and spinning mills, and the declaration of large dividends such as those paid by the principal English, German, French, and Swiss mills, give promise of its growth into a leading textile industry in the near future in a somewhat similar manner to the rise of the trade in jute, out of which since its beginning more than 20 millions sterling has been earned in profits; the source of raw supply for this great trade is India, and jute cultivation is a widespread and profitable industry for the Indian planter. In like manner the experimental cultivation of ramie in suitable soil and climates is well worthy of the attention of tobacco, sugar, indigo, ginger, and other planters. Lands on which the vine grows are well suited for ramie growing; on tobacco, sugar, indigo, and certain cotton soils it will thrive luxuriantly; the great height to which its stems shoot fit it well for serving the purposes of hedges on plantations of this kind, and the crop if given a medium amount of attention in cultivating can then be cut down and find a remunerative market. In regard to the decorticated fibre produced by the "Faure" machine, Messrs. Larmuth and Sons, engineers, of Salford, England, will be pleased to forward samples of this product to any people interested in the matter. This decorticator does not produce bark ribbons or ramie ribbons, but a clean fibre, ranking equally on the market to the costly hand-cleaned China grass of China.

On the occasion of her recent tour in India, it may be mentioned, Her Royal Highness the Princess of Wales carried with her and wore a large assortment of costumes specially manufactured for her by the London Ramie Mills, with which she expressed herself more than satisfied, and which excited general admiration. A large use for this fibre will arise when raw supplies are cheaper.

The possibilities of the fibre's profitable spinning and weaving in non-flax-growing countries, and where linen manufacture is limited, are great, as it can be produced cheaper than the latter, which accounts for the marked success which has attended its manufacture in France and Germany since the establishment of the industry in these countries little more than 10 years ago.

PACKING VANILLAS FOR SHIPMENT.

Since the Instructor in Tropical Agriculture at Kamerunga, Cairns, introduced the vanilla vine to North Queensland, considerable attention has been paid to the cultivation of this valuable product. From what has been seen at various exhibitions of the cured vanilla bean from Cairns, it is quite evident that the cultivation of the plant in suitable parts of tropical Queensland will be attended with success. It appears, however, that even in countries such as those below mentioned the science or art of properly packing the product to avoid mouldiness has not yet been properly understood. The "Ceylon Tropical Agriculturist" discusses this important matter as follows, and quotes prices for vanilla beans from "Tropical Life," as given below:—

At the May public sales held in London, prices realised for this article were rather easier than those paid at the April auctions. In proportion to the rather indifferent quality, due to unscientific curing and packing, prices realised, as shown below, were fairly good, and ranged from barely steady to about 6d. below the sales in April.

What might have been a nice useful lot of Tahitis, saleable at 2s. 6d. to 2s. 9d. per lb., were found on being opened to show signs of poor curing and a tendency to become mouldy. Shippers' attention, and not only those connected with Tahiti, has repeatedly been called to the mistaken idea of stuffing vanilla tins as full as possible, and then soldering on the cover so as to render the inside hopelessly air-tight. No vanillas should be packed absolutely air-tight, and least of all common and insufficiently dried Tahitis. The beans swell on the voyage, and also sweat copiously; if, therefore, the tins are rigidly air-proof, the condensed vapour clings to the tin, and hangs over the beans. On opening, one finds the inside not only damp and rusty, but corroded and rough with scales of rust, and the excess of moisture can be squeezed out of the bundles. The result is that almost immediately signs of mould appear, and in a week, when buyers arrive to inspect the shipment, the beans are all more or less badly moulded, and worth only 4d. per lb. or so, instead of 2s. 6d. This serious loss is entirely due to insufficient drying, packing in air-tight soldered tins, and also through squeezing into eighty large pitch-oil tins nearly 100 cwt. of beans, which should have been distributed between 100 or even 120 tins, so as to allow for aeration and expansion on the journey across.

The ideal method of packing is to use tins of about 10 lb. to 15 lb., or rather more, each provided with a well-fitted turned-over-edge lid that grips the sides. Such a tin is all but air-tight, though able to allow gases or excess of moisture to escape and so prevent any chance of the contents becoming damp or even mouldy. It is not even necessary to paper the lid on to or down to the sides of the tin, as that prevents such ventilation taking place. It is advisable, in order to ensure the lids remaining tight down on to the tins, either to solder the corners only or else to tie them with strong twine, but not to solder all round the tin. If the Tahiti shippers find it necessary to keep to their well-known large soldered pitch-oil tins they should perhaps make two small punctures at the top and bottom of the tins at the extreme corners, pack the contents less tightly and well dry their beans after curing; it would then be found that the outturn would be more satisfactory and far less liable to deterioration than with present methods.

Prices realised ruled as follows:—

Seychelles.—Fair quality, 2½ to 8 in., 5s. 9d. to 7s. 6d. per lb.

Bourbon.—Fair quality, 6½ to 7½ in.; 8s. per lb.; fair quality, 6½ in., 7s. 9d. per lb.

Madagascar.—Fair quality, 6½ to 7 in., 9s. 6d. per lb.; 6 to 6½ in., 7s. 6d. to 9s. 3d. per lb.; 4 to 7½ in., 6s. 6d. to 8s. 6d. per lb.

Zanzibar.—Common cure, brown and split, 6s. to 7s. per lb.

Java.—Common brown, 6s. per lb.

Ceylon.—A single bin, dry brown, of poor flavour, 5 to 7 in., 2s. per lb.

THE COCOA-NUT.

The cocoa-nut palm is a native of the tropics, and is not known to occur at a distance of more than 28 deg. north or south of the equator. It is at its best farther to the south than Hawaii. While the tree has largely been considered a sea-shore plant, and while many authorities have considered that salt water was essential to its most perfect development, recent cultural experiments have demonstrated that a much more vigorous and productive growth may be obtained far inland.

The cocoa-nut tree demands above all things good drainage. It thrives neither in swamps nor on rocks. The roots are thick, fleshy fibres, there being no taproot. The roots seem to be specially adapted for the storage of considerable quantities of water, but wherever they reach the level of permanent standing water, or wherever stagnant waters rise above the level of roots already formed, these rot and the tree sends out new and shorter roots only as far as the perfectly drained and well aerated soil extends. The tree is a heavy feeder, requiring cultivation and fertilisation, giving best results where these can be augmented by irrigation or abundant rainfall.

Another factor is that the tree grows best in windy locations. Specimen trees in sheltered valleys, where the wind never strikes them, are more liable to be spindling and unhealthy. The requirements of the cocoa-nut may be summed up in having light and room in windy locations, where the soil is rich and well drained, and there is abundant artificial or natural irrigation.

In planting the cocoa-nut only the ripe nuts, carefully collected, from neither very young nor very old trees, should be taken. Nuts intended for planting should not be dropped or thrown from the tree, for if the shell is cracked within the husk germination will not take place. The husk contains enough moisture for germination, provided the seed bed is moist and half shaded. In drier locations the nuts should be planted on their sides and partially covered with loose, mellow earth, leaving about 2 in. of their surface exposed. The seed beds thus prepared should be kept moist, but not soaked. Germination takes place in from 2 to 6 months. As soon as the plumule pushes out through the husk on one side and roots are just appearing below, the seedling is ready to transplant to its permanent location.

Two methods of planting are in vogue. In India pits 3 to 6 ft. across and 2 to 3 ft. deep are dug 27 to 36 ft. apart. These pits are filled with sand, manure, ashes, compost, rotted leaves, and rich soil. The germinating seed is half buried in the centre of the pit, and no further cultivation is given except to clear the weeds, and no more fertilisation than to utilise the cocoa-nut grove for pasture lands.

The newer method, and one which has been proved to give better results, is to plough the land and work the whole surface into the best possible state of cultivation. Frequent tillage follows with the planting of leguminous intercrops and the addition of commercial fertilisers. The trees should never be planted closer than 30 ft., or at the rate of from 110 to 150 trees per acre. Close planting in rows, as seen in many native groves and in dooryards around Honolulu, and for that matter, all through the islands, is neither a satisfactory nor profitable method of cocoa-nut cultivation.

There is the widest variation in the number and size of cocoa-nuts borne by individual trees. Some trees may produce only a dozen nuts in the course of a year, others bear from 150 to 200, or more. Some trees begin to bear in their fifth or sixth year, others not for ten or fifteen years. The greatest profit in cocoa-nut cultivation will come by planting only nuts from trees known to have the most desirable qualities, both in early maturity and prolific yield. The trees continue to bear for 50 or 60 years or more, but during this time cultivation should be continued and the supplies of plant food taken from the soil returned in the form of organic or commercial fertilisers.

When the plantation begins to bear, the nuts are gathered as they ripen, the husk removed, either by hand or modern decorticating machines, of which

there are many styles and patterns designed for the dual purpose of husking the nut and saving all of the fibre from the husk. The nuts are then split in halves and placed on drying floors in the sun. In 24 hours the meat curls loose from the shell and may be taken or emptied out. The meat is then dried for 1 or 2 days in the sun, and finished off by artificial heat, or the meats are sliced by machinery and finished in steam-heated drying houses.

The Samoan cocoa-nut is considered the best variety for cultivation in Hawaii because it commences to bear at an earlier age and is more prolific than the Hawaiian tree. A cocoa-nut orchard in good bearing should yield from 10,000 to 15,000 nuts per acre per annum. Yields of nearly double these amounts have been obtained in other lands, but the Hawaiian average is considerably under this. The best practice would be not to produce copra for export, but to extract the cocoa-nut oil on the plantation where the nuts are grown. The flesh of the nuts contains on an average about 35 per cent. of oil. If this is extracted by modern commercial methods at least 30 per cent. of the oil is recoverable, and the cake, or waste, becomes a valuable by-product for feeding cattle or for returning to the land as fertiliser.—“*Philippine Agricultural Review*.”

CHILE CULTURE.

GREEN CHILE.

A large amount of the chile is eaten in the green stage. In fact, practically all the chile used during the summer months is green. Before the chile is ready for use it ought to be almost full grown. This stage can be recognised by the green pod having a noticeable bright or shiny lustre, and being firm enough to resist considerable pressure when pressed between the thumb and fingers. If pressed tightly the pod will emit a slight crackling sound. When the chile is picked too immature the shrinkage in weight is soon noticed, and the pods shrivel so much that the peeling of them becomes more tedious. Green chile for canning purposes should be mature, and the pods ought to be smooth and as large as possible. A typical pod for canning should be from 4 to 6 in. long, or longer, and about 1 in. or more in diameter at the stem end, gradually tapering down to a point. It should be smooth, straight, and fleshy. Aside from taking more time to peel a short wrinkled pod and one sunken at the stem there is more waste to it.

A number of pickings of good, mature, green chile for canning purposes can be made during the season. The earlier the plants come into bearing and the better care they receive, the more green chile they will produce. At the station during the season of 1907 the experimental field planted plants were picked six times, while the transplanted plants from the cold frame were picked nine times. The picking of the green chile is somewhat slow, and the pickers, aside from being careful not to break the branches containing smaller pods and blossoms, should be quick with their hands and able to tell at a glance a pod that is mature enough for the cannery without having to stop and examine it. It takes some little experience to pick good chile and pick it fast. At the station it was observed that young inexperienced pickers at first picked very slowly, and the larger part of the chile they picked had to be sorted over before it was sent to the cannery. The amount of chile the average experienced person can pick depends upon the crop of mature pods the plants have at the time. Since the amount varies it is impossible to give definite figures for all cases, but from six different pickings at the station in 1907, the men picked from 35.5 to 45.5 lb. per hour.

Green chile can be kept for home use for some time after the crop has been gathered, by placing the green pods in dry sand, or, by piling up the vines and keeping the pods from freezing. In this way green chile may be had for use part of the winter months. If green chile is placed out in the sun it will turn yellowish white, and become worthless, while if placed in the shade it will colour up, and can be used as red chile.

RED CHILE.

Red chile is the term generally used for ripe pods whether they are red, black, or other colours. If no green chile is picked from the plants during the summer season two different pickings may be made of ripe pods. The first picking may be made whenever there are enough of the ripe pods on the plants to pay, while the last picking is made just before it freezes. The pods ought not to be picked until they are perfectly ripe. If picked partially unripe the green parts of the pods will be of a yellowish white colour when they are dried in the sun. After the red chile is picked it has to be dried before it can be stored. Two methods for drying the chile are practised by the Mexican chile growers. The most common way is to pile it up in medium-sized piles from 4 to 6 days. At the end of this period the chile is spread out on the ground about two pods thick, and left there until thoroughly dried, when it is stacked and stored or shipped away.

It is claimed that by leaving the chile in piles for a few days before it is spread out the dry pods will be more fleshy than when not submitted to this treatment. The other and less common way of drying it is by tying four or six pods together and making long festoons which are then hung out where they will dry.

Air-dried chile is very light and bulky. The dry pods will not stand any pressing without breaking. The time it takes chile to dry when spread out on the ground in the fall varies from 6 to 8 weeks. The red chile loses considerable in weight during the drying process. The amount of weight lost depends to some extent upon the quality of the pods. If the pods are all perfectly ripe and sound when picked the loss will be less than if the pods are more or less green. From 2,819 lb. of fresh ripe chile, containing some pods that were not perfectly ripe, put out to dry 8th November, 1907, 747 lb. of dry chile were sacked and weighed 2nd January, 1908. According to these figures there were 2,072 lb. loss, or 73.5 per cent. of the original weight. On 8th November, 1907, 50 lb. of selected fresh ripe pods were spread out to dry, and from this lot 16 lb. of the dried chile were weighed and sacked 2nd January, 1908. Thus it is seen that the loss in weight was 34 lb., or 68 per cent. Another 50 lb. of good, matured green chile were spread out on the same date, and when dried it weighed 10 lb. In this case the original weight was reduced 40 lb., or 80 per cent. From these two tests it is noticed that the difference between the green and ripe chile was 6 lb., or 12 per cent. in favour of the ripe pods. The amount of red chile produced per acre can be increased by drying the green chile picked in the fall in the shade.

In the preparation of the red or green chile for use the flower stems, seeds, and veins* are discarded, and represent so much waste. Aside from being quite a task to remove the stem and seeds from the pod, the fine dust coming off from the chile is exceedingly irritating to the nostrils and eyes. In order to obtain some data on the proportion of stems, veins, and seeds to the pod, and the time necessary to remove these, 50 lb. of ripe, dry pods were weighed, and the waste removed. The following are the results in figures:—29 $\frac{3}{4}$ lb. of clean pods, 5 $\frac{1}{4}$ lb. of stems, $\frac{1}{2}$ lb. of veins, and 14 $\frac{1}{2}$ lb. of seed. It took 23 $\frac{1}{2}$ hours to remove the stems, seeds, and veins from the pods. From these figures it will be seen that there is a large waste to red chile. Taking into consideration so much waste and the amount of work required to remove it, and the disagreeable features of the work, it would be better for the consumer to buy the cleaned pods. Ordinarily the red chile is retailed locally at 15 to 20 cents per lb. Taking the 50 lb. of red chile, they would bring from 7.50 dollars to 10.00 dollars. Then, according to these figures, the consumer pays 15 to 20 cents per lb., or 3.03 dollars to 4.05 dollars for the 20 $\frac{1}{4}$ lb. of waste in the 50 lb. of chile bought, plus 2.35 dollars, the cost

* The word *veins* as used in this bulletin is a literal translation of the Spanish word *venas*, which is the common Spanish name given in this section to the *placenta* or the pithy core in the chile pod. The author has adopted the word *veins* on account of not having found a better common term for the *placenta*.

of removing the stems and seed. In other words, the 29 $\frac{3}{4}$ lb. of cleaned pods cost the consumer 9·85 dollars to 12·35 dollars, or approximately at the rate of 33 to 41 cents per lb. It might be said that the consumer could better afford to pay 30 to 40 cents per lb. for the cleaned pods than 20 cents for those uncleaned.—Extract from "Bulletin No. 67," New Mexico College of Agriculture.

CASSAVA.

FAMINE-FIGHTING IN INDIA.

We have frequently advocated in this Journal the planting of cassava in Queensland. It is from the tubers produced by the cassava or manihot plant that the tapioca of commerce is obtained. Every housewife knows the value of tapioca as an excellent and nutritious form of farinaceous food, especially in the form of light puddings for children and invalids. Although the plant thrives splendidly on all our coastlands, and even in the Far West of the Central Districts, nothing has yet been done in the way of turning the tubers to practical use. We see these exhibited at every agricultural show, and their value has been explained over and over again by the exhibitors, but all to no purpose. Yet Queensland imports large quantities of tapioca from other countries.

Cassava flour from the West Indies is largely used by textile manufacturers in Lancashire and elsewhere, and the price paid for it ranges from £14 to £16 per ton. In Queensland the yield all over the State will average 9 tons per acre, and in such rich soil and in such a climate as North Queensland, considerably more. An acre of cassava is worth more than an acre of sugar-cane. As a feeding stuff for cattle, the actual profit on feeding bullocks on cassava is nearly 50 per cent., on maize-fed bullocks it is 15 per cent., and, as to cost, it is two-thirds in favour of cassava. At the Florida (U.S.A.) Experimental Station, a profit of 59·10 per cent. was made by fattening beasts on cassava.

An acre producing 40 bushels of maize yields 1,187 lb. of starch, while an acre of cassava, producing only 6 tons of tubers, will yield 2,400 lb. of starch. This starch contains 3 per cent. of sugar and 1·68 per cent. of fibre. Maize contains 4 per cent. of sugar and 2·20 per cent. of fibre. A rainfall of 14 in. per annum is sufficient to secure a heavy crop of cassava, as it is peculiarly drought-resisting, and will flourish in arid regions as well as in the most humid.

There are two kinds of cassava, the sweet and the bitter. The former is innocuous, or at least contains very little of the poison known as hydrocyanic acid in its skin. The latter contains a far greater quantity, but the poison is entirely confined to the juice. So volatile is prussic acid that if the sliced roots are left in the sun for a while they may be eaten by man or beast with impunity. Cassava flour is worth about £6 per ton in England.

We are led to revert to the subject of the growing of cassava by an article which appeared on the 30th September of this year in "The Morning Bulletin," Rockhampton, taken from the London "War Cry" of 20th June last. From this it appears that the Salvation Army in India is doing good work in helping the famine-stricken Indians by means of plentiful supplies of cassava flour. A Mohammedan maulvi or priest had an interview with Commissioner Booth-Tucker, and the latter, after explaining the objects of the army, got on to the subject of its work in fighting the famine by means of cassava flour. Addressing the maulvi, who was deeply interested and most willing to assist, Commissioner Booth said:—

"Well, you see, Maulvi Sahib, men have bodies as well as souls, and often the best way to reach the soul is through the body. While we are seeking to minister to their spiritual needs, we see them battling desperately, and often unavailingly, with temporal distress, and our religion would not be worth much if our hearts did not go out in longing desire to help them. For instance, there is this terrible famine and scarcity with the consequent high

prices of food prevailing all over North India. When we were in Travancore a few months ago we found the famine did not trouble them at all. We asked the reason, supposing it to be the abundant rainfall and rich soil. But it was not so. They, too, had been subject to famine and scarcity till a plant, well known to commerce and largely grown in other tropical climates, had been introduced, and this proved a splendid famine-fighter and drought-resister. This food was then actually selling at 80 lb. to the rupee, though famine rates had affected the prices of rice, wheat, and all other ordinary grains. On all sides we saw the familiar plant growing. No cottage was without its little garden patch. It was the cassava or maniocca, the tapioca of commerce. But here, as a food, it had been Indianised to suit the tastes of the people. The large tuber roots, resembling huge potatoes, were boiled, sliced, sun-dried, and finally ground into a fine and tasty flour, which could either be eaten alone or mixed with other kinds of flour, according to the taste and resources of the family. Thus, every little homestead had been rendered famine-proof, as a tiny patch would grow sufficient for a year's supply, and the surplus could be sold in the open market. An average crop would range from 6 to 20 tons per acre, according to the care and cultivation it received, and its value would run from 100 to 300 rupees per acre, according to the demand there might be for the food."

"But," exclaimed the Maulvi, "can this crop be grown in the Punjaub? I have more than 1,000 vigahs of land, and should like to try some."

"Certainly, Maulvi Sahib," I replied. "It will grow in almost any part of India. In fact, we are even trying some here in Simla, though I fear it is too cold. But up to an elevation of 4,000 ft. it will flourish. It does not need irrigation, and if planted just before the monsoons, will take care of itself. It will also resist drought. And another advantage is that it does not need to be harvested quickly like wheat and ordinary grains, but can be left in the ground for months without spoiling. In its sun-dried form it will keep for a year, and can be transported to any distance in any climate."

"It seems, indeed, to be a godsend," said the maulvi. "My manager tells me that it makes delicious cakes, as well as ordinary chappatties, and that it mixes with almost any flour, but, best of all, with wheat flour, which, as you know, is the principal article of food here in the Punjaub."

The maulvi was quite right; cassava is a godsend to the vast famine-stricken territories of India.

It is only 3 months since we started our famine-fighting campaign, and here in brief are some results already accomplished—

Arrangements have been made for securing 30 tons of the new food.

Three tons have been supplied, at the request of the Famine Commissioner, to the poor houses in the United Provinces. The Government officials report that in each case the people have taken to the new food, although previously they were very sceptical about its acceptance.

Our orphanages have also been supplied. The children have taken to the food, and have asked that it may become permanent on their bill of fare.

The Indian grain merchants, who have their fingers upon the pulse of the people all the time, after carefully testing the food, have pronounced strongly in its favour, and, were we willing to do so, would gladly take from us all we can supply.

In large gatherings of our Indian soldiers we have shown the food and given particulars as to probable prices. They have begged us to make immediate arrangements for supplies to be obtained and distributed.

We have obtained cuttings of the cassava plants, and have distributed them where we have land, arranging for the regular cultivation of the plant, and for its introduction and explanation to neighbouring farmers.

We have begun to form a kind of alliance with leading Indian merchants for the regular growth, production, and distribution of the new food, thus helping to erect all over India one of those Nature-made barriers against the

ravages of famine. A new era of hope in connection with this terrible scourge is thus opened up.

By the sale of the food at a price which will cover initial expenses, and is yet from 50 to 100 per cent. cheaper than all other grains, we are able to turn the money over and over, and cover a far wider area than would otherwise have been possible.

At the same time, by the introduction of this simple plant, the Salvation Army appears before the people of India in an altogether new light, and the bread of life is rendered doubly welcome, because with the offer of salvation we are able also in a time of dire distress to bring the "bread that perisheth."

LEAF-BLAST OF THE SISAL PLANT.

The "Journal d'Agriculture Tropicale," always prompt to note anything of importance in connection with tropical agriculture, remarks, on the subject of sisal leaf-blast, which we explained in our issue of last March to be no disease, but only an effect of certain weather conditions:—"Under the name of 'leaf-blast,' a physiological trouble has been reported from various districts, where plantations of sisal exist, characterised by the presence on the leaves of large and numerous red or yellow blotches, which very shortly cause the decomposition of the leaves and fibres. This trouble made its appearance in Mexico about 30 years earlier, and caused grave anxiety to the planters, who believed it to be a new parasitic scourge. Happily, there was no need for a scare, as earnest study of the affected leaves disclosed the fact that it was a question of an accident of a physiological nature, due to great heat supervening on a rainy period.

"The leaf-blast has been observed in many parts of Queensland where the cultivation of sisal is rapidly extending, as well as at the Solomon Islands. It has been noticed that the damage was most severe on plants growing in rich soils. The only method of forestalling the damage is to decorticate the leaves immediately the first spots appear—that is to say, before the fibre has lost its value; but this means can only be recommended in the case of leaves sufficiently developed for the decorticating process."

We have to thank our excellent contemporary for this advice, which will be of value to all planters here who have machinery to enable them to act on it.—Ed. "Q.A.J."

CALABASH PIPES.

By R. S. NEVILL.

Herewith is submitted a picture of the celebrated pipe calabash of the shape desired by pipe manufacturers. These pipes are becoming very popular, and are, it is said, fast supplanting the meerschaum. It is said they are the sweetest smoking pipe of any, and colour well and prettily. These calabashes are worth £12 per 1,000, or nearly 3d. each, when of the right shape, and should prove a very profitable thing for the small farmer. They are grown like pumpkins, the vine allowed to run along the ground. The calabashes should occasionally be turned over to keep them from discolouring. Care should be taken that they are placed in such a position as to get the proper curve on the stem, for without curved stems they are valueless. Getting the proper curve can be assisted by so placing the calabash as to force the curve, and fixing it in that position so that it will not move. This can be done with clods or stones. In the issue of the "Queensland Agricultural Journal" for December, 1907, will be found an illustration of a pipe manufactured from a calabash gourd.

The Government Botanist, Mr. F. M. Bailey, gives it as his opinion that these gourds will do best above the range, as in the warmer coastlands they might produce gourds too large for the purpose required.



CALABASH GOURD.



Animal Pathology.

TICK FEVER, OR REDWATER.

By SYDNEY DODD, F.R.C.V.S., Principal Veterinary Surgeon and Bacteriologist.

This disease is known throughout the world under various names. In America it is known as Texas Fever, in consequence of its having in that country first been observed in the State of Texas. The name by which it is commonly known in Queensland is Tick Fever, or Redwater. This latter synonym is an unfortunate one, as it gives the impression that Redwater is essential to this complaint; in fact, numbers of stock-owners in Queensland go so far as to declare that Tick Fever and Redwater are two quite separate diseases. It will, however, be seen later on that the passing of red-coloured urine is not at all an essential feature in every case of the disease.

Other names are Moor Ill, Wood Ill, Blackwater, Bovine Distemper, Bloody Murrain, Tristeza, Bovine Piropiasmosis, Bovine Hæmoglobinuria, &c.

DEFINITION OF THE DISEASE.

Tick Fever is a specific infectious disease of the blood of cattle, caused by the introduction and multiplication of very minute animal parasites (or protozoa) belonging to one of the smallest forms of animal life, these parasites being conveyed to the affected animals by means of certain cattle ticks. The disease is marked by high fever, by destruction of the small red cells of the blood, thus liberating the red colouring matter, which may be so great when excreted by the kidneys as to colour the urine red, by enlargement and softening of the spleen or melt, enlargement of the liver, jaundice, anæmia, emaciation, and death in from 10 to 90 per cent. of cases in which the disease makes its appearance naturally. The disease is not contagious—that is, provided an animal suffering from the disease were free from ticks, it cannot infect an animal placed in contact with it. It is not transmitted by the air, saliva, manure, urine, or in any other known manner save by cattle ticks or the direct inoculation of infected blood.

HISTORY OF THE DISEASE.

The place where this disease first originated is unknown, but it has been known to exist for some hundreds of years (although its cause was not then recognised) in some countries of Europe, such as South France, England, Ireland, Italy, Turkey, Roumania. It is also prevalent in the United States of North America, Central and South America, West Indies, Mexico; South, East, West, and North Africa; Finland, practically the whole of Southern Asia, Philippine Islands, Germany, South Russia, and lastly Australia. In countries where the disease has existed for a long period the annual loss is not so great as in those places where it has been newly introduced, owing in a great part to the fact that in the former countries cattle contract the disease when quite young, at which period of life they are very resistant to the effects of Tick Fever, and then immunity is maintained by subsequent repeated tick infection so long as they remain in an infected district. This is well illustrated in Queensland. When Tick Fever first broke out in the North the losses were enormous, but at the present time one hears little about the losses in the Northern districts, owing to the fact that practically all the cattle there are now immune, and the losses one occasionally hears of are chiefly due to breaking down of immunity by some means, or the introduction of susceptible cattle. On the other hand, in Southern Queensland, where the disease is comparatively quite new, the losses are very heavy at the present time

wherever cattle become naturally infected. It is no uncommon thing to hear of a small farmer losing almost the whole of his cattle through Tick Fever. The virulency of the disease, however, varies a good deal in different countries and in different districts.

Owing to the fact that there are quite a number of persons in Queensland who deny that cattle tick has anything to do with the disease known as Tick Fever, it is thought necessary to give a short account of the events which took place in the United States, resulting in the discovery of the organism which causes the disease, and succeeded beyond dispute in proving that the cattle tick was the agent which conveyed the organism from the blood of one animal to another.

In America it was observed for a number of years that, whenever cattle were transported from the Southern to the Northern States, Northern cattle, which passed subsequently over these roads or grazed on the pastures over which the Southern cattle had fed, invariably became ill, and the majority died, although the Southern cattle remained healthy. In the same way Northern cattle that were taken South almost always were attacked with the same disease. The enormous losses caused scientific observers to study the disease, with the result that it became evident it was too dangerous to allow Southern cattle to go North during the hot weather, and in 1891 a quarantine line between the Northern and Southern States was established. Dr. Curtice, an American veterinarian, was the first to suggest that ticks might play some part in the disease.

In 1888 the organisms causing Tick Fever were first seen in the blood of Roumanian cattle by Babes; but Smith, in the United States, was the first in 1889 to recognise their true character, while in 1889 and 1890 Kilborne, also in the United States, proved by experiments made under natural conditions that the presence of the cattle tick was essential to the transmission of the disease. In experiments made in the United States in 1892 and 1893 it was found that animals which had gone through a mild attack of tick fever, when exposed to tick-infested pastures, had obtained a considerable amount of protection. The methods adopted subsequently for producing such a non-fatal attack were by injecting blood into an animal from one which had already gone through an attack, or by the less certain way of placing ticks on a susceptible animal. By the term "susceptible" animal we mean one which is liable to the disease. In 1895 to 1897 further experiments were made with the object of proving that animals could be protected by inoculating them with blood from an infected beast, and in 1897 inoculation experiments were first carried out in Queensland. More recent work appears to be directed towards finding a satisfactory dip which will not only destroy ticks but keep them off an animal for some time, or clearing the land of ticks, as in the United States, and also towards the discovery of some material which will destroy the organisms in a sick animal's body, and so reduce the heavy mortality among affected animals.

Turning to Queensland, it appears that Tick Fever was first seen in the Northern Territory of South Australia in 1885. Of course, the exact nature of the disease was not then known. Whether the tick and the disease were introduced into Australia simultaneously is not known, though from evidence to be obtained it probably was the case. Nor is it known how or when the disease was first introduced, but it appears to have been prevalent on the Roper River, in the Northern Territory of South Australia, some years before it was reported in Queensland. In Queensland, at any rate, the evidence goes to show that the cattle tick did not exist before the advent of Tick Fever. Why the disease should have been confined to the Northern Territory for a time, and then make such rapid strides, is easy to comprehend when one studies the development of the cattle industry in Queensland of recent years. No great spread took place until boiling-down

works were erected on the Albert and Norman Rivers. What occurred then was similar to that just described as occurring in the United States. Although the travelling cattle remained apparently well, the cattle living in the country covered by the former, became ill and died, and an old stockman who lived in Northern Queensland informs me that at first the disease was strictly confined to the stock routes. In 1895 Mr. Pound, who investigated the disease with the late Dr. J. S. Hunt, succeeded in establishing the fact that it was identical with Texas Fever of America. A commission, consisting of Dr. Hunt and Mr. William Collins, was sent to the United States in 1896 for the purpose of more fully establishing the identity of the two diseases.

When the nature of the disease was ultimately recognised in Queensland, steps were taken by the Stock Department to prevent its spread, but in 1895 it had spread south and east, and in 1896 it had reached the eastern coast. In spite of the various regulations as to quarantine of cattle, dipping, &c., the disease gradually extended its area until, at the present time, the whole of the coastal district and inland as far as the coastal range may be said to be more or less infested with ticks, and in those localities where cattle ticks are present, but no tick fever, it only needs the introduction of an animal which has recovered from the disease to set up a fresh centre of infection.

It is recognised that a mere statement that ticks convey the disease known as Tick Fever is not sufficient unless it can be substantiated by proof, and, therefore, it is considered necessary to give a brief summary of what has been done in this direction by various scientists.

To find out whether the disease could be communicated from infected to non-infected susceptible cattle in the same paddock without the aid of ticks, ticks were carefully removed from infected cattle. In this way no ticks could mature and infest the ground. The clean cattle were then placed in a clean paddock with non-infected susceptible cattle. The result was that the latter all remained healthy, proving that ticks were necessary to convey the disease. To prove that Tick Fever could be produced by ticks alone, without infected cattle actually being present, mature ticks were scattered about clean paddocks, and susceptible cattle placed therein contracted Tick Fever. Finally, it was proved that young ticks hatched out in glass tubes in the laboratory from the eggs of infected ticks could, when placed on susceptible cattle, set up the disease at any time of the year; and I myself have seen eggs of ticks dropped from infected cattle in South Africa, sent to London, hatched out in a laboratory there, the larvæ or young ticks placed on a cow, and producing the disease 7,000 miles away from the place where the mother of the ticks became infected. At one time it was thought that something in the manure of cattle was capable of infecting animals. That this was not the case was proved in experiments where the dung of infected cattle was scattered over pastures, and also where blood and crushed organs of animals dead of Tick Fever were scattered about. Susceptible animals grazing over this land from which ticks had been cleared off remained quite healthy.

THE CAUSE OF THE DISEASE.

The direct cause of Tick Fever is a very minute parasite known scientifically as *Piroplasma bigeminum*. It belongs to the lowest known form of animal life. This organism is present at some period in the blood of every animal affected with Tick Fever, although in some cases it is extremely difficult to find, even with prolonged search with a microscope by an experienced observer; and by injecting blood containing it into a susceptible animal it will always set up the disease, thus proving that the organism is the cause. In an article like this one, which is written for the information of stock-owners, it is not necessary or desirable to go into scientific details as to what

takes place when this organism gains entrance to the blood, beyond stating that, after gaining the circulation, various changes occur in the parasite, which may be observed if the blood is kept under observation under the microscope. At first a single small body is seen inside the infected red cell. This, later on, divides into two incompletely separated small round bodies. Then these two bodies gradually enlarge, until they become pear-shaped and connected by their narrow extremities (hence their scientific name). At this period of the disease about 1 or 2 per cent. of the red cells are invaded, very rarely as many as 10 per cent. These parasites at this stage, fill up about a third of the red blood cell. The infected red cell then shrinks and breaks up, liberating the parasite and also the colouring matter of the blood, which is excreted by the kidneys. In bad cases the destruction of red cells is so great that their number may fall from 7,000,000 or 8,000,000 per c.m.m. (their normal number) to 2,000,000 per c.m.m. or even less.

LIFE HISTORY OF THE CATTLE TICK.

A knowledge of the life history of the cattle tick is very important, as without this, it is impossible to explain many features of the disease, or to take proper steps for preventing its spread. Mr. Tryon, the Government Entomologist, has worked out the history of this tick, and the lengths of time occupied in the various stages are those given by him.

The Queensland cattle tick (*Rhipicephalus australis*) is, as its popular name indicates, chiefly found on cattle, but it is also seen on horses, on which animals it may mature. It is also said to develop on sheep. In describing the life history of the tick it will perhaps be most convenient to start at the point where the mature female has dropped off its host to the ground, when it seeks a sheltered spot and lies quietly. Within 3 days, according to Tryon, the female tick commences to lay eggs, which operation may last from 10 to 21 days. The number of eggs deposited varies from 1,500 to 3,000. As the egg-laying proceeds, the tick shrinks in size until it finally shrivels up and dies when the process is ended. The eggs are brown in colour, with a waxy look, and generally clustered together in masses. They are very resistant to the adverse conditions of temperature, and will survive exposure to very low temperatures or to that of summer heat, providing they are not exposed to the direct rays of the sun. Under favourable conditions, depending upon warmth, moisture, &c., the eggs develop in from 21 to 42 days, but, if conditions are against them, such as a cold winter, they may remain dormant for several months, and then hatch out when the weather becomes warmer. The young tick or larva is a very small parasite, about the size of a very small pin's head, or even less. It possesses six legs, and is of a light-brown colour. Soon after the hatching it crawls, together with a number of its fellows, up blades of grass, sticks, shrubs, posts, &c., until large clusters of them are collected ready to seize hold of anything that may pass by. In this condition the young tick is able to live some months without food, but, providing the tick cannot find a suitable animal to which to attach itself, it cannot develop, but ultimately dies. Should, however, an ox brush against them, they immediately attach themselves to the beast, selecting for preference the soft parts of the skin, such as inside the thighs, flanks, or forelegs, escutcheon, belly, &c. Once there, they insert their rostrum or beak into the skin, and commence to suck blood. It must be pointed out that they can cause fever at this stage, even though they can scarcely be seen. After being on the animal about a week, the larval tick moults or casts its skin, and becomes a nymph. During this change it acquires another pair of legs, so that it now has eight. The tick does not drop off its host, however, but remains attached. At about the second week of its attachment the tick changes its skin a second time, and is now an adult. At this stage of life the male and female ticks are about the same size. The female

does not increase in size until after it has been fertilised by the male. This takes place shortly after the adult stage is reached. After this, the female gradually increases in size until about 24 hours before dropping, when it swells up enormously. This rapid development of the female accounts for the opinion held by some stock-owners that their cattle were quite free from ticks one day and the next day ticks were dropping off them. The entire period spent by a tick upon an ox is rarely less than 3 weeks, and in cold weather it is sometimes considerably longer. The male does not increase to the great size that the female attains, and when it has accomplished its end by fertilising the female it dies. When the female tick has attained its full size it drops to the ground, and soon commences to lay eggs, thus completing its life cycle, the whole period occupying from 6 to 10 weeks in warm weather, but longer in winter. This is supposing the young tick finds a host as soon as it is hatched.

Although the young ticks are very active, neither they nor the adults are able to travel very far, but they may be transported long distances by mechanical means, such as floods, winds, animals, carts, railway trucks, clothing, &c. Mr. Pound reports having found them carried mechanically on goats, kangaroos, and wallabies, hence the always present danger that new areas may become tick-infested by other means than travelling cattle or horses.

It is necessary, before the disease can appear in a district, that a fully mature female tick shall have developed upon an animal carrying the causal organism of Tick Fever in its blood, and that the eggs laid by these ticks hatch out and the larvæ attach themselves to susceptible cattle. While the ticks are sucking blood to enable themselves to live, they are at the same time inserting the parasite of Tick Fever into their host. These parasites develop in the blood of the ox, and an attack of Tick Fever results. Once the tick has dropped off a beast it is very rarely that it attaches itself again to another animal, so that it is seen that the tick does not convey the disease direct from one animal to another, but that the organism is passed through the eggs of the tick to the larval ticks, and it is these latter which have the power of infecting cattle.

It may not be out of place here to point out one or two of the arguments brought forward by some to try and show that ticks have nothing to do with Tick Fever.

1. They say that there are localities in Queensland which have only recently been infested with ticks, where the cattle are highly susceptible to Tick Fever, and yet no cases of the disease occur! This may be explained as follows:—

It has been previously pointed out that cattle ticks can and do live and mature on horses. Now, the horse is not susceptible to Cattle Tick Fever, and when a tick has matured on this animal it loses its infectious property, and from it springs into being a non-infected race of ticks. It will thus be readily understood that horses can carry ticks into a new Tick Fever free district (it is no new thing to hear that a stock-owner's cattle have been dipped in order to free them from ticks, but the horses have been forgotten), and the progeny of these ticks may get on to susceptible cattle, but until they are able to suck blood containing the organism of Tick Fever from a beast, naturally these ticks are powerless to transmit that which they never had.

2. It is also sometimes brought forward as another proof against the transmission by ticks, that cattle go down with Tick Fever and no ticks at all are to be found on the animal. Now, if ticks really are absent, and very often they are so small that they escape notice unless carefully sought for by an experienced searcher, it may be explained in this way. Probably these particular animals had already recovered from an attack of Tick Fever, and had become so-called "immune." As a matter of fact, in the strict sense of the word, they are not immune, but chronically infected, as they all carry the causal organism

in their blood. As, however, will be presently shown, this immunity is not absolute, but as the result of impaired vitality, due to various causes, such as over-driving, injury, starvation, rough handling, &c., an animal may lose its immunity, and suffer from another attack of Tick Fever without having a tick on it!

With regard to young calves: A calf has at the time of birth, and for some months after, such a great power of resistance that it may go through an attack of the disease and an owner never notice anything wrong with it. This resistance lasts, but in a diminishing degree, until the age of about nine months. One of the reasons for this state of affairs may be that the power to manufacture fresh red blood cells is very great in young animals, and that the destruction of these cells by the causal organisms of Tick Fever is not greater than the young animal's vital power can cope with, although this does not explain every feature.

PERIOD OF INCUBATION,

or the time elapsing between the exposure to ticks and the appearance of the disease. This depends a good deal upon the temperature, and the stage of development of the ticks the animal is exposed to. It will be understood that if a susceptible animal is placed in a hitherto clean paddock with cattle from which ticks have just fallen, the time before the disease shows itself in the former animal will be much longer than it would had it been exposed after all the eggs had hatched out and the young ticks were waiting for their host. In the first place, it may be from 30 to 60 days before the animal is observed to be ill. In the latter case, symptoms may set in from 10 to 15 days in summer. It is thus seen that, after natural exposure to tick infection, the disease develops in from 10 to 60 days, depending upon weather conditions, the longer periods being in winter and the shorter in summer—cold retarding and warmth assisting the hatching of the eggs. In the summer, symptoms may become apparent in as short a period as 10 days after the young ticks have attached themselves. With artificial inoculation of blood, the period of incubation is shortened again, and symptoms may appear in from 6 to 10 days, seldom, however, in the former, but chiefly in the latter time.

SYMPTOMS.

The severity of an attack usually appears to be in direct relation to the age of the animal—that is, very young animals, as a rule, suffer slightly, whilst aged animals suffer severely and often die. Most writers on Tick Fever describe two types of the disease—viz., (1) the acute, and (2) the chronic; but, for convenience, the two will here be described together, and the points in which the chronic or mild type differs will be subsequently indicated. The first thing usually noticed, if the animal is under observation, is a rise of temperature, and this may exist two or three days before any other symptom is seen. The temperature may be 104 degrees Fahr. on the first day of illness, and may then increase to 106 or 107 degrees. The more acute the case and the hotter the weather, the greater the rise. A sudden drop in the temperature after the animal has been fevered a few days is a bad sign, as it indicates collapse, and perhaps death. The pulse is increased in frequency, the animal begins to breathe more rapidly, it looks depressed, ceases to chew the cud, refuses to eat, and the muffle is hot and dry. It leaves the herd, and lies down or stands alone with its back arched. The head is lowered, and the ears droop. The foregoing symptoms, however, are not special to Tick Fever, as cattle show them in other cases of illness. The eyes often become swollen and sometimes jaundiced; if made to move, the animal staggers as if drunk. Saliva dribbles from the mouth and also collects around its corners. In some cases delirium may set in, and the animal charge anyone who approaches. If pregnancy is advanced, the cow often slips her calf. The supply of milk is diminished or stops altogether.

Constipation is present in the early stages, but may be followed by diarrhoea. In the more advanced cases, the dung may be stained a yellowish-brown by bile. In the severe cases, it is to the urine that one's attention is most frequently drawn. It has already been pointed out that one of the results of the growth of the causal organism in the blood of an infected beast is the destruction of the red cells of the blood, thus liberating the colouring matter. This is excreted by the kidneys, and gives the urine its red colour. At first, the urine is thick and muddy in appearance, then in bad cases it often increases to a red colour. Sometimes the colour may be such a deep red that the urine looks more like stout. As has been stated, destruction of red blood cells goes on in all cases of tick fever, but in the mild cases this is so slight or so gradual that to the eye no change takes place in the urine at all. It appears quite normal. Hence the opinion commonly expressed by stock-owners in Queensland that there are two quite distinct diseases—viz., Tick Fever and Redwater—because, they say, in Tick Fever there is no Redwater. It will be seen that the name "Redwater" is not a good one for this disease, because it does not cover all cases. In advanced cases of the disease, the blood becomes watery owing to the great destruction of cells. The blood is a good means of diagnosing Tick Fever, because if one takes a small drop of blood, smears it on a glass slide, stains, and then examines it under a microscope, one can generally find some of the organisms in the blood cells when the fever is at its height, but they are often very difficult to find when the animal is recovering, and it is, of course, not a practical means of diagnosis for a stock-owner to adopt.

As to the usual course of the disease: If the case is a very severe one, death usually takes place in from 4 to 7 days after symptoms set in, but if the animal be made to exert itself, death may occur in from 24 to 48 hours in these cases.

In non-fatal cases, the temperature gradually falls to normal (about 101.5 degrees Fahr.), the animal gradually regains its appetite, but recovery is very slow, and may take weeks or even months. The mortality ranges as high as 90 per cent. in hot weather, but in colder weather, or where the type of the disease is milder, the death rate is much lower. The mild or chronic cases are usually seen in young calves, or in animals that have survived one attack and their immunity has become broken down. In these cases the temperature does not usually go above 105 degrees Fahr. There is loss of appetite, constipation, loss of condition, but there is usually no Redwater. In some cases a relapse may occur in about three to six weeks from the disappearance of the acute symptoms, hence the necessity for taking care of an animal when it is recovering.

[TO BE CONTINUED.]

ERRATUM.

STOMACH WORMS IN SHEEP.

An error occurred in our reply in the last issue of the Journal to Mr. R. Irving, on the value of lucerne for reducing the number of stomach worms in sheep. It was there stated that green lucerne had a "costive" effect. This is obviously a mistake; it should have read "a laxative" effect.

Statistics.

COMMONWEALTH METEOROLOGY.

RAINFALL OF QUEENSLAND.

TABLE SHOWING THE TOTAL RAINFALL FOR EACH MONTH OF THE YEAR IN THE AGRICULTURAL DISTRICTS OF QUEENSLAND.

| STATIONS. | 1907. | | | | 1908. | | | | | | | | |
|-----------------------|-------|------|------|-------|-------|-------|-------|--------|-------|-------|-------|------|-------|
| | Sept. | Oct. | Nov. | Dec. | Jan. | Feb. | Mar. | April. | May. | June. | July. | Aug. | Sept. |
| <i>North.</i> | | | | | | | | | | | | | |
| Bowen | 0.51 | 0.06 | 3.71 | 6.39 | 10.14 | 5.63 | 9.46 | 3.73 | 0.99 | 0.45 | 0.88 | 0.51 | 0.96 |
| Cairns | 1.35 | 0.68 | 5.35 | 28.33 | 27.02 | 8.03 | 20.60 | 5.99 | 3.05 | 0.59 | 3.70 | 2.12 | 0.74 |
| Geraldton | 1.36 | 1.42 | 6.45 | 33.82 | 44.39 | 13.27 | 39.00 | 14.23 | 18.52 | 2.64 | 8.11 | 3.66 | 2.81 |
| Herberton | 0.12 | 0.17 | 3.41 | 9.57 | 9.29 | 5.02 | 8.92 | 1.40 | 0.38 | 0.31 | 2.36 | Nil | 0.51 |
| Hughenden | Nil | 1.66 | 0.66 | 7.75 | 0.98 | 5.18 | 6.91 | 0.30 | Nil | 0.05 | 0.68 | Nil | Nil |
| Kamerunga State Nurs. | 1.19 | 0.53 | 2.76 | 29.82 | ... | 7.47 | 25.75 | 4.60 | 3.363 | 0.76 | 4.85 | 1.58 | ... |
| Mackay | 0.12 | 0.12 | 5.76 | 9.70 | 9.28 | 3.83 | 17.43 | 14.82 | 3.25 | 1.29 | 1.65 | 0.71 | 2.27 |
| Rockhampton | Nil | 0.47 | 3.72 | 4.42 | 3.84 | 9.64 | 9.77 | 2.62 | 0.85 | 0.10 | 1.08 | 0.84 | 0.20 |
| Townsville | 0.14 | 0.03 | 2.82 | 24.26 | 12.21 | 6.69 | 9.03 | 0.38 | 2.22 | Nil | 1.70 | ... | 0.28 |
| <i>South.</i> | | | | | | | | | | | | | |
| Biggenden State Farm | 0.24 | 1.99 | 2.50 | 5.55 | 2.37 | 9.82 | 9.84 | 2.97 | 0.74 | 0.43 | 0.49 | 2.33 | 1.39 |
| Brisbane | 0.10 | 1.37 | 4.25 | 3.21 | 2.80 | 8.43 | 18.19 | 2.45 | 2.40 | 0.17 | 0.77 | 2.83 | 0.67 |
| Bundaberg | Nil | 1.70 | 2.90 | 2.99 | 4.77 | 2.82 | 7.35 | 4.13 | 0.67 | 0.39 | 0.75 | 1.56 | 1.10 |
| Dalby | 0.15 | 0.69 | 5.18 | 1.44 | 0.17 | 4.88 | 7.61 | 0.11 | 0.37 | 0.63 | 0.14 | 1.80 | 1.13 |
| Esk | 0.57 | 0.50 | 3.76 | 3.72 | 2.61 | 10.06 | 17.04 | 2.83 | 1.07 | 0.23 | 0.46 | 2.75 | 2.16 |
| Gatton Agric. College | 0.15 | 0.71 | 3.01 | 4.55 | ... | 3.38 | 10.74 | ... | 0.10 | 0.16 | 0.6 | 2.71 | 1.84 |
| Gindie State Farm ... | 0.16 | 0.61 | 1.57 | 4.42 | 0.20 | 7.17 | 6.25 | 0.02 | 0.112 | ... | 0.40 | 1.27 | ... |
| Gympie | 0.47 | 1.20 | 3.05 | 5.49 | 6.26 | 11.77 | 80.8 | 1.87 | 2.00 | 0.38 | 1.16 | 2.87 | 1.37 |
| Ipswich | 0.05 | 0.78 | 4.45 | 3.40 | 1.32 | 6.63 | 13.77 | 2.71 | 1.14 | 0.12 | 0.47 | 3.23 | 1.19 |
| Maryborough | 0.25 | 2.74 | 3.49 | 5.81 | 5.62 | 8.07 | 11.40 | 2.52 | 1.05 | 0.46 | 0.81 | 1.98 | 1.05 |
| Roma | 0.04 | 1.04 | 3.70 | 2.51 | 0.04 | 6.38 | 2.51 | 0.22 | Nil | 0.55 | 0.63 | 1.38 | 1.12 |
| Roma State Farm ... | ... | ... | ... | ... | ... | ... | ... | ... | ... | ... | 1.27 | 0.73 | ... |
| Tewantin | 0.55 | 1.05 | 3.12 | 7.36 | 10.42 | 12.47 | 14.39 | 7.59 | 8.66 | 0.75 | 1.97 | 2.70 | 2.18 |
| Warwick | 0.01 | 1.37 | 3.25 | 3.13 | 0.76 | 4.52 | 6.65 | 1.40 | 0.15 | 0.80 | 1.24 | 2.49 | 1.96 |
| Westbrook State Farm | Nil | 1.08 | 4.76 | 3.23 | 0.43 | 8.03 | 1.41 | 1.40 | 00.5 | ... | 0.49 | 1.97 | ... |
| Yandina | 0.80 | 1.44 | 2.87 | 3.05 | 8.37 | 14.47 | 16.62 | 5.45 | 4.59 | 0.58 | 2.64 | 2.18 | 1.50 |

NOTE.—The rainfall data in this table are compiled from telegraphic reports, and must be considered as approximate only.

GEORGE G. BOND,
Divisional Officer

General Notes.

A NEW STUMPING MACHINE.

A new tree-feller has been placed on the market by Messrs. John Cooper and Sons, of 289 Elizabeth street, Melbourne (says "The Scientific Australian"). In construction it diverges from previous types of forest devil in that the rotary hand action has been superseded by a reciprocatory one. The change provides for obviating some of the disadvantages previously experienced. Among those said to be remedied is the waste of time involved in taking grips, and the inconvenience of many in transportation. In the new appliance a continuous motion is provided by the lever attachment at the upper end of two tooth wheels, as shown in the illustration. Both the forward and backward action of the lever draws on the rope, while the lever also acts as a

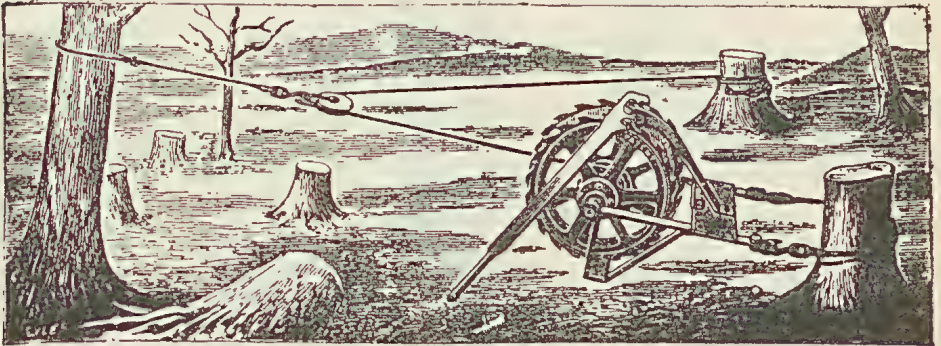

Trees uprooted by this appliance will not fall upon and incapacitate either the operator or his mechanical assistant. There is a great pressure on the portion of the rope leading from the off anchor, and this draws the tree in that direction.

ratchet, preventing any back run should the machine be left unattended. The transportation of any previous kinds was a matter of carting, or otherwise carrying a heavy instrument to the scene of operations. This is not necessary in the Cooper devil, as it may be moved about on its own wheels. The total weight of the appliance is 250 lb., and in preliminary tests a wire cable tested to 60 tons was broken by two men. As the appliance may also be used as a crane, or for wool and ensilage pressure, as well as numerous other purposes, it commends itself to the rural community.

[This appears to be the machine invented by Mr. Dan O'Connor, a settler in the Busseton district of Western Australia. It is fully described in "The W.A. Journal of Agriculture" for September, 1908.—Ed. "Q.A.J."]

POST-HOLE DIGGING SIMPLIFIED.

Two tools are frequently used for forming post holes—namely, a pick or bar, and also a shovel. This renders the task both slow and tedious. Thanks to the Cyclone Woven Wire Company, of Swanston street, Melbourne, an implement combining the functions of a pick and a shovel is now available. In its cycle of operations it lessens, lightens, and facilitates the work. At the bottom of a handle is a box jaw, as shown in Fig. 1 of illustration. Connected with the handle, and running parallel to it, is a hand lever, controlling a second jaw. When closed the cavity of each jaw is opposite the other (Fig. 2).

With the jaws apart the digger or handle jaw is thrust into the ground at one stroke. The lever is then pressed downwardly. This forces the second jaw also into the ground, and brings it into contact with the other, thus capturing the soil, which can be quickly removed and discharged. The Cyclone Woven Wire Company report that this implement is much used for erecting "Cyclone" wire fencing and other work.—"Scientific Australian."

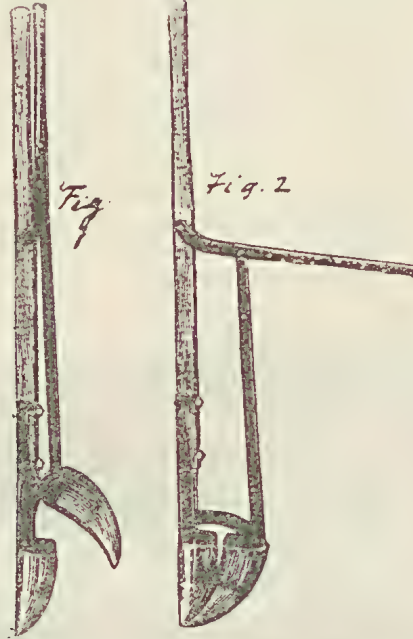

Showing in the first figure the appliance ready to be struck into the ground. The second illustrates position under earth, when the lever and its charge are drawn.

[This much resembles a post-hole digger placed on the market by Messrs. Alfred Shaw and Co. twenty-five years ago, in Queensland, the only difference being that the jaws consisted of two curved spades. These were only suitable for use in clayey or loamy soils.—Ed. "Q.A.J."]

A NATIVE BIRD DESTROYING THE SPARROW.

Both the "Agricultural Gazette" of New South Wales and the "Journal of Agriculture" of South Australia record an article by Mr. C. T. Musson, Hawkesbury College, New South Wales, on the discovery that a certain bird, hitherto a stranger to, or at least unknown, in many parts of Australia, is a deadly foe of the ubiquitous sparrow. In the "Lachlander and Condobolin District Recorder" (26th February, 1908), the following statement appeared:—

"Mr. A. J. Taylor, of Wheatacre, informs us that during the past few months he has noticed the presence of numbers of large birds, blue in colour, with black heads, which are very destructive to sparrows. In fact, since the arrival of these aerial cannibals, sparrows are practically an unknown quantity about Wheatacre.

"We wrote Mr. Taylor for further information, and received the following reply:—'Re the bird that takes the sparrows, it is quite true there is not a sparrow left about the place, and there were hundreds here. I tried in every way to get rid of them, but since those birds came we got rid of them. We never saw the birds before; they are strangers. There are about four of them in a flock, and they keep together. I do not think it is a hawk, though they

balance in the air like a hawk. They keep after the grasshoppers, but they are dead on the sparrows. The other birds are not frightened of them. They are very quick on the wing, and, when flying, spread out the tail.

"Three days later came a specimen for identification: it is the Ground Cuckoo-Shrike (*Pteropodocys phasianella*). The head and neck are dark-grey; breast and lower back dull white crossed by narrow black bars; wings, upper side black; under side white; tail forked; the terminal half black. It is about the size of a small pigeon, but more slender; total length from tip of bill to end of tail, 14 in. Commonly, they make use of their legs a good deal, not flying much. Insects are the chief food, and we do not hear of them doing any damage.

"This is a most interesting fact, which should be noted by all dwellers west of the range where the bird is found. If this is to become a fixed habit, which probably it now will, it would appear that the sparrow has at least one enemy in its new abode. Sportsmen should take note and act up to the fact stated. Nature would here seem to be coming in, for evidently the cheeky little interloper is no longer to have such a peaceful time as it has had in the past. The 'balance is beginning to kick,' and we may congratulate ourselves that at least one cause is in operation which will help in bringing the sparrow down in numbers to such reasonable limits as will preserve a due balance of life forms, and not allow this particular bird to become unduly plentiful.

"Broinowski, in his 'Birds of Australia,' says:—'This bird is found in most parts of the interior of Australia, frequenting principally plains and thinly-timbered forest country. It is always seen on the ground, in small flocks, from two to eight in number.'"

LOGAN AND ALBERT A. AND P. SOCIETY.

At a recent meeting of the members of the above society a rule was passed fixing the date of the Annual Show for the last Wednesday in July.

The next show will, therefore, be held on 28th July, 1909.

ANNUAL REPORT OF THE DEPARTMENT OF AGRICULTURE AND STOCK, 1907-08.

The usual Annual Report of the Under Secretary for this Department has been issued, and a copy will be supplied free to all subscribers to the "Queensland Agricultural Journal." Included in the Report are the Agricultural and Pastoral Statistics for the same year issued by the Government Statistician.

Answers to Correspondents.

DESTROYING HEAVY TIMBER.

SELECTOR, Eumundi.—

The use of saltpetre for getting rid of heavy forest timber has proved successful in many instances, and also in our own experience. Last year we saltpetred several large useless ironbark and stringybark trees, and early in the present year these were successfully burnt. One large peppermint-tree was cut down by a contractor, who did not know that the tree had been dosed, although he saw the plug, and concluded that someone had bored into the tree to see if it was sound. To his surprise, when he built a fire near the butt end, it burnt splendidly until nothing was left but a few of the smaller branches. Trees of this class, not treated, took many days and heavy labour to burn off. The quantity of the salt to use is only regulated by the diameter of the tree and the size of auger used. Your storekeeper can tell you the price of saltpetre. The reason for plugging the hole after charging is, that during heavy driving rains the water would fill the hole, dissolve the salt, which would gradually be washed out instead of being absorbed by the sap. The blood-red gum exuding from a bloodwood tree would carry out all the salt if the hole were not plugged. The quickest way of getting rid of big stumps is to blow them out or shatter them by an electric discharge of dynamite, gelignite, or blasting gelatine. The cost of the exploder is £4 10s.; 100 yds. of cable, 35s.; reel of connecting wire, 12s. 6d.; electric detonators, 25s. per hundred; dynamite or gelignite, 50s. per case of 50 lb.; blasting gelatine, 65s. per case of 50 lb.; total cost of outfit, £10 12s. 6d. The agents for the Nobel-Glasgow explosives are Messrs. Dalgety and Co., Brisbane.

Note that when the first charge of saltpetre is seen to be absorbed, the hole must be charged a second time. When the second lot is absorbed, ring-bark the tree and wait till it dies before firing. The whole process may take a year.

Cost of a stump-jump disc plough used to be £28 10s. Cost of improved stump-jump cannot be given. There has been so little call for these implements that Messrs. Smellie and Co. no longer stock them.

As you quote this Journal as the source of your information concerning clearing heavy timber, we are surprised that you apparently have overlooked the notices and advertisements of the Trehwella Stumping Jacks. These appliances are very powerful, and at the same time cheap. See Vol. XVI., December, 1905, and June, 1906; Vol. XVII., October, 1906; Vol. XVIII., April, 1907.

We understand from the Brisbane agent for these jacks, Mr. A. Robinson, Civil Service Stores, that Messrs. Trehwella have perfected a most powerful apparatus, worked by wire rope and one horse, which will shortly be placed on the Brisbane market, when a public demonstration of its powers will be given.

SPRAY FOR PRICKLY PEAR.

T. P. KEYS, Belmore, Surat.—

1. Mr. J. C. Brünnich, Agricultural Chemist, recommends an arsenical solution containing about 1 per cent. of arsenic. Generally, use ordinary dipping solution (used for ticks on stock), only made four times as strong as recommended for cattle-dipping.

We have used a solution prepared by Mr. Pickburn, dispenser at the Boggo-road Gaol, with great success. The solution was merely poured on to

the prickly pear by means of a watering can, without slashing the leaves. The result was that the pear was destroyed, the roots even withering up. We do not know the price of the solution, but believe it is very cheap.

An arsenical solution may be prepared by dissolving 4 lb. of caustic soda in a few gallons of water, and adding 8 lb. of arsenic. Boil until all is dissolved; add about 1 gallon of tar; boil again, and make up to 100 gallons with water.

2. Any arsenical spray, even if very weak, will kill off couch grass, which, however, will recover and grow again after a few months. The solution should not be used on the cultivation ground or flower beds, as it will infallibly destroy all vegetation, and our experience with Mr. Pickburn's solution is that nothing will grow for months after application on the soil which has been operated on.

SWELLING ON MARE'S HEAD.

YARRAMAN, Yandaran.—

Question.—A light harness mare for the past two years has had a slight swelling on the top of the head, just behind the ears, and about equally divided from the centre on each side downwards. It is hard, and does not appear to be painful or slightly so. For the past two weeks it has been gradually getting larger, still hard, and apparently painless. There is no appearance of sore place or wound. Information is requested how to treat.

Answer.—The question was referred to the Chief Veterinary Surgeon to the Department, and he advises:—"This growth cannot be removed except by a surgical operation requiring special skill and experience on the part of the operator. Unless the mare is a valuable one, and is required for show purposes, I would advise you not to operate, but to try the effect of a little of the following ointment rubbed into the swelling every fourteen days:—

| | | |
|--------------------|-----------|--------|
| Biodide of mercury | | 1 dr. |
| Vaseline | | 3 oz." |

FODDER GRASSES.

DAIRY FARMER, New Farm.—

1. The hilly country in the Coomera and Pimpama districts is well adapted for dairy farming. It is well-watered, grassed, and sheltered.

2. Kangaroo Grass (*Anthistiria ciliata*) enjoys an excellent reputation as a fodder grass. There are many forms of it, some deep-green, some shiny, others hairy, but all are equally good fodder. It must not be confused with *Andropogon refractus*, which is sometimes called Kangaroo Grass. This is abundant in Southern Queensland. It gives a large amount of fodder, but has a harsh stem, and can only be depended on for summer feed. The true Kangaroo Grass grows luxuriantly in some situations on "sour" grazing country. It is advisable to have a variety of grasses, with white clover as pasture.

3. Sugar-cane tops alone are not very nutritious as fodder. The usual method of using the cane as feedstuff is to chop it up and mix it with molasses. Some of the sorghums when fed to stock will produce worms, and sugar-cane is said to have a tendency to do the same, but not to such an extent as the sorghums.

OIL SEEDS AND BUCKWHEAT.

INQUIRER, Atherton.—

Some time ago Messrs. J. G. Cook and Co., Produce Markets, Prahran, were purchasers of sunflower seed at £14 per ton, and peanuts at £20 per ton. For buckwheat they offered £7 to £12 per ton. The above delivered in Melbourne.

WARTS ON COWS' TEATS—COWS ABORTING.

H. K. B., Bell.—

Mr. Sydney Dodd, Chief Veterinary Surgeon to the Department of Agriculture and Stock, says:—

1. Warts on the teat are most conveniently removed when the cow is dry. Those situated on the outside of the teat may be removed by tying a piece of thread or horse hair tightly round the base if the wart is long and narrow; this prevents the flow of blood to the wart, which eventually drops off. If the wart is short and broad, it should be lightly rubbed every few days with a piece of caustic silver or potash, or even strong nitric acid, care being taken that none of the surrounding flesh comes in contact with the caustic.

2. Your cows appear to be suffering from contagious abortion. For treatment and prevention see the "Queensland Agricultural Journal" for December, 1905, p. 249; June, 1907, p. 352; and May, 1908, page 271. In the Journal will also be found eight notices on "Warts on Cattle."

POST-HOLE DIGGER—CATTLE DIP.

"POST-HOLES," Mullet Creek.—We are not aware of a hand machine which may be relied upon to work in hard land, or where roots, stones, or other obstructions exist.

Two kinds have been tried and discarded. They worked where the soil was a nice deep alluvial, and in a sandy loam; but the hole made was much too small for the ordinary run of substantial split-posts.

The usual selling price is from 5s. to 6s., but Brisbane firms do not carry any stock now. See description and illustration of such an implement in this issue.

CATTLE DIP.

No better dip can be erected than from one of the plans illustrated in the pamphlet issued by the Department; they are based on the experience of the departmental officers, and, while small details may be varied, the general plan would be followed with advantage; for a herd of twenty cows, 10 ft. in length in the bottom may do, and the yards may be reduced in proportion; the clay soil would be more reliable for holding than sand, and the latter would cost about 2s. 2d. less for excavation than the clay. If timber were used, then the clay excavated could be used for puddling, and the cost reduced proportionately.

CREAM TESTS.

CREAM SUPPLIER, Gladstone.—

"Cream Supplier" asks which of the two following cream tests is correct. The tests are from two separate factories:—

| No. 1 TEST. | | | No. 1 TEST. | | |
|-------------|-------|-------------|-------------|-------|-------------|
| Cream. | Test. | Butter Fat. | Cream. | Test. | Butter Fat. |
| Lb.
63 | 37 | 27 | Lb.
63 | 37 | 28·03 |
| No. 2 TEST. | | | No. 2 TEST. | | |
| 51 | 38 | 22 | 51 | 38 | 23·30 |

Answer.—Your question has been referred to Mr. R. Winks, senior grading officer to this Department. His decision is as follows:—

“Your correspondent is evidently confusing the butter-fat content of each lot of cream with the amounts of commercial butter produced. The amount of butter fat in 63 lb. cream, testing 37 per cent., is 23·31 lb.; and that from 51 lb. cream, testing 38 per cent., is 19·38 lb. butter fat. The difference in the amounts given by each factory is accounted for by the amount of over-run allowed in each case—*i.e.*, the difference between the quantity of butter fat in a given quantity of cream, and the amount of butter it should produce. In the one instance about 15 per cent. and the other 20 per cent. over-run is allowed. The probabilities are that the former is the more correct of the two, as a 20 per cent. over-run is altogether too high, and would point to either inaccuracy in the testing of the cream or carelessness in the manufacture of the butter. Most Queensland butter factories use Mr. O’Callaghan’s chart.”

Times of Sunrise and Sunset at Brisbane, 1908.

| DATE. | SEPTEMBER. | | OCTOBER. | | NOVEMBER. | | DECEMBER. | | PHASES OF THE MOON.
<small>H. M.</small> |
|-------|------------|-------|----------|-------|-----------|-------|-----------|-------|---|
| | Rises. | Sets. | Rises. | Sets. | Rises. | Sets. | Rises. | Sets. | |
| 1 | 6·3 | 5·34 | 5·29 | 5·47 | 4·53 | 6·5 | 4·46 | 6·28 | 4. Sept. ☾ First Quarter 6 51 a.m. |
| 2 | 6·2 | 5·31 | 5·28 | 5·48 | 4·57 | 6·6 | 4·46 | 6·29 | 10 " ○ Full Moon 10 23 p.m. |
| 3 | 6·1 | 5·35 | 5·27 | 5·48 | 4·57 | 6·7 | 4·46 | 6·29 | 17 " ☽ Last Quarter 8 33 " |
| 4 | 5·59 | 5·35 | 5·25 | 5·49 | 4·56 | 6·8 | 4·46 | 6·30 | 26 " ● New Moon 0 59 a.m. |
| 5 | 5·58 | 5·35 | 5·24 | 5·49 | 4·55 | 6·8 | 4·46 | 6·31 | |
| 6 | 5·57 | 5·36 | 5·23 | 5·50 | 4·55 | 6·9 | 4·46 | 6·32 | |
| 7 | 5·56 | 5·36 | 5·22 | 5·50 | 4·54 | 6·10 | 4·46 | 6·32 | |
| 8 | 5·55 | 5·37 | 5·21 | 5·51 | 4·53 | 6·10 | 4·46 | 6·33 | 3 Oct. ☾ First Quarter 4 14 p.m. |
| 9 | 5·54 | 5·37 | 5·20 | 5·51 | 4·53 | 6·11 | 4·46 | 6·34 | 10 " ○ Full Moon 7 3 a.m. |
| 10 | 5·53 | 5·38 | 5·19 | 5·52 | 4·52 | 6·12 | 4·47 | 6·35 | 17 " ☽ Last Quarter 1 35 p.m. |
| 11 | 5·52 | 5·38 | 5·18 | 5·52 | 4·52 | 6·13 | 4·47 | 6·35 | 25 " ● New Moon 4 47 " |
| 12 | 5·51 | 5·39 | 5·17 | 5·53 | 4·51 | 6·13 | 4·47 | 6·36 | |
| 13 | 5·49 | 5·39 | 5·16 | 5·54 | 4·51 | 6·14 | 4·47 | 6·36 | |
| 14 | 5·48 | 5·39 | 5·15 | 5·54 | 4·50 | 6·15 | 4·48 | 6·37 | |
| 15 | 5·47 | 5·40 | 5·13 | 5·55 | 4·50 | 6·16 | 4·48 | 6·38 | 2 Nov. ☾ First Quarter 0 16 a.m. |
| 16 | 5·46 | 5·40 | 5·12 | 5·55 | 4·49 | 6·16 | 4·48 | 6·38 | 8 " ○ Full Moon 5 58 p.m. |
| 17 | 5·45 | 5·41 | 5·11 | 5·56 | 4·48 | 6·17 | 4·49 | 6·39 | 16 " ☽ Last Quarter 9 41 a.m. |
| 18 | 5·43 | 5·41 | 5·10 | 5·56 | 4·48 | 6·18 | 4·49 | 6·40 | 24 " ● New Moon 7 53 " |
| 19 | 5·42 | 5·42 | 5·9 | 5·57 | 4·48 | 6·19 | 4·49 | 6·40 | |
| 20 | 5·41 | 5·42 | 5·9 | 5·58 | 4·48 | 6·20 | 4·50 | 6·41 | |
| 21 | 5·40 | 5·43 | 5·8 | 5·58 | 4·47 | 6·20 | 4·50 | 6·41 | |
| 22 | 5·39 | 5·43 | 5·7 | 5·59 | 4·47 | 6·21 | 4·51 | 6·42 | |
| 23 | 5·38 | 5·44 | 5·6 | 5·59 | 4·47 | 6·22 | 4·51 | 6·42 | 1 Dec. ☾ First Quarter 7 44 a.m. |
| 24 | 5·37 | 5·44 | 5·5 | 6·0 | 4·47 | 6·23 | 4·52 | 6·43 | 8 " ○ Full Moon 7 44 " |
| 25 | 5·35 | 5·44 | 5·4 | 6·1 | 4·46 | 6·23 | 4·53 | 6·43 | |
| 26 | 5·34 | 5·45 | 5·3 | 6·1 | 4·46 | 6·24 | 4·53 | 6·44 | 16 " ☽ Last Quarter 7 12 " |
| 27 | 5·33 | 5·45 | 5·2 | 6·2 | 4·46 | 6·25 | 4·54 | 6·44 | |
| 28 | 5·32 | 5·46 | 5·1 | 6·3 | 4·46 | 6·26 | 4·54 | 6·44 | 23 " ● New Moon 9 50 p.m. |
| 29 | 5·31 | 5·46 | 5·1 | 6·3 | 4·46 | 6·26 | 4·55 | 6·45 | 30 " ☾ First Quarter 3 40 " |
| 30 | 5·30 | 5·47 | 5·0 | 6·4 | 4·46 | 6·27 | 4·55 | 6·45 | |
| 31 | ... | ... | 4·59 | 6·5 | ... | ... | 4·56 | 6·46 | |

The Markets.

PRICES FOR FRUIT—ROMA-STREET MARKETS.

| Article. | SEPTEMBER, |
|--|--------------------|
| | Prices. |
| Apples, per case | ... |
| Apples (Hobart), per case | 9s. to 13s. |
| Apples (American), per case | 13s. 6d. |
| Apricots, Local, per packer | ... |
| Asparagus (Westbrook State Farm), per dozen bundles | ... |
| Bananas (Queensland), per dozen | 2d. to 3d. |
| Custard Apples, per case | ... |
| Gooseberries, per quarter-case | ... |
| Lemons, per case | 9s. to 12s. |
| Lemons, rough, per case | ... |
| Loquats (Sydney), per case | 6s. to 6s. 6d. |
| Mandarins, per case | 7s. to 9s. |
| Mangoes, per case | 5s. to 8s. |
| Oranges, Queensland, per case | 5s. 6d. to 7s. 6d. |
| Passion Fruit (Sydney), per case | ... |
| Papaw Apples, per quarter-case | ... |
| Persimmons, per case | ... |
| Pineapples, rough, per dozen | 1s. to 4s. |
| Pineapples (Ripley's), per dozen | ... |
| Pineapples, smooth, per dozen | 3s. to 8s. |
| Rosellas, per sugar bag | ... |
| Strawberries, per dozen cardboard boxes | 4s. 6d. to 5s. 6d. |
| Tomatoes (small), per quarter-case | 3s. to 8s. |
| Tomatoes (spotted), per quarter-case | 4s. |
| Tomatoes (prime), per quarter-case | 5s. to 7s. 9d. |

SOUTHERN FRUIT MARKET.

| | |
|--|--------------------|
| Apples (Hobart) per case | 5s. to 12s. |
| Apples, American, per case | 12s. to 15s. |
| Apples, Tasmanian, per case | 12s. |
| Bananas, Fiji, Gros Michael, per case | 18s. |
| Bananas, Fiji, sorts, per case | 24s. |
| Bananas, Fiji, ordinary, per case | 15s. 6d. to 16s. |
| Bananas, Fiji, per bunch | 3s. to 7s. 6d. |
| Bananas, Queensland, per case | 12s. to 13s. |
| Bananas, Queensland, per bunch | 4s. to 5s. 6d. |
| Chillies, per bushel | ... |
| Lemons (Lisbon), per case | — to 10s. |
| Loquats (Sydney), per case | — to 5s. |
| Mandarins (Local), per case | 18s. |
| Mandarins, Emperor, per case | ... |
| Oranges, Queensland, per case | 12s. |
| Oranges, Queensland, Navel, per case | 15s. |
| Passion Fruit (Sydney), choice per case | 6s. to 7s. |
| Passion Fruit (medium), per case | 3s. 6d. to 4s. 6d. |
| Passion Fruit (small), per case | 1s. 6d. to 2s. |
| Pears, Victorian, per case | ... |
| Pears, Tasmanian, per half-bushel case | ... |
| Pineapples (common), choice, per case | 8s. to 10s. |
| Pineapples (medium), per case | 6s. |
| Pineapples (Ripley Queens), per case | 8s. to 10s. |
| Strawberries, Queensland (choice), per three-quart tray | 6s. to 7s. |
| Strawberries (medium), per three-quart tray | 2s. to 3s. |
| Strawberries (small and inferior), per three-quart tray | 1s. |
| Tomatoes, Queensland, choice (coloured), per quarter-case | 6s. to 7s. |
| Tomatoes, good, per quarter-case | 4s. to 5s. |
| Tomatoes, small | Unsaleable. |

PRICES OF FARM PRODUCE IN THE BRISBANE MARKETS FOR OCTOBER.

| Article. | OCTOBER. | |
|---------------------------|----------|---------------------|
| | Prices. | |
| Bacon, Pineapple | lb. | 8½d. to 10d. |
| Barley, Malting | " | ... |
| Bran | ton | £7 to £7 5s. |
| Butter, Factory | lb. | 1s. 2d. |
| Chaff, Mixed | ton | £5 10s. |
| Chaff, Oaten | " | £6 10s. to £8 10s. |
| Chaff, Lucerne | " | £5 to £6 10s. |
| Chaff, Wheaten | " | £3 to £4 |
| Cheese | lb. | 8½d. to 9d. |
| Flour | ton | £9 15s. to £10 |
| Hay, Oaten | " | £9 |
| Hay, Lucerne | " | £5 to £5 10s. |
| Honey | lb. | 2¼d. to 2¾d. |
| Maize | bush. | 4s. 4d. to 4s. 5d. |
| Oats | " | 3s. 8d. to 4s. |
| Pollard | ton | £7 5s. |
| Potatoes | " | £6 15s. to £15 |
| Potatoes, Sweet | " | ... |
| Pumpkins | " | ... |
| Wheat, Milling | bush. | 4s. 11d. |
| Wheat, Chick | " | 4s. 11d. |
| Onions | ton | £15 to £18 |
| Hams | lb. | 10d. to 1s. 0½d. |
| Eggs | doz. | 7½d. to 8¼d. |
| Fowls | pair | 3s. 4d. to 4s. 11d. |
| Geese | " | 6s. 3d. to 6s. 6d. |
| Ducks, English | " | 3s. 7d. to 4s. |
| Ducks, Muscovy | " | 4s. 10d. to 5s. 6d. |
| Turkeys (Hens) | " | 7s. to 8s. |
| Turkeys (Gobblers) | " | 15s. to 18s. |

ENOGGERA SALEYARDS.

| Animal. | SEPTEMBER. | |
|--------------------------------|------------|----------------------------|
| | Prices. | |
| Bullocks | ... | £10 10s. to £12 12s. 6d. |
| Cows | ... | £8 17s. 6d. to £10 2s. 6d. |
| Merino Wethers (woolly) | ... | 25s. 9d. |
| C.B. " | ... | 18s. 6d. |
| Merino Ewes | ... | 21s. 9d. |
| C.B. " | ... | 17s. 9d. |
| Lambs | ... | 18s. |
| Pigs (Porkers) | ... | 32s. |

Farm and Garden Notes for December.

FIELD.—The grain harvest will now be nearing completion, and although the results are not likely to constitute a record it will in all probability turn out to be very satisfactory to the wheat-growers. The principal factor operating against an increased yield is that many farmers who formerly grew wheat and barley have turned their attention to dairying, which offers larger and quicker returns.

The dry weather which prevailed during the months of August and September gave rise to grave fears for the harvest, but the subsequent timely rainfall came just in time to save the crop. The estimates of the probable yield have varied so considerably that it will be well to wait until the harvest is over before calculating on the result.

Given favourable weather, maize, panicum, imphee, Kafir corn, and sorghum may be sown. Arrowroot, ginger, and sweet potatoes may be planted.

KITCHEN GARDEN.—Gather cucumbers, melons, vegetable marrows, and French beans as soon as they are fit for use. Even if they are not required, still they should be gathered, otherwise the plants will leave off bearing. Seeds of all these may still be sown for a succession. Tomatoes should be in full bearing, and the plants should be securely trained on trellises or stakes. Take up onions, and spread them out thinly on the barn floor until the tops wither sufficiently to pull off easily. They should then be graded into sizes, and sent to market or stored in a cool place. Where there is an unlimited supply of water, and where shade can be provided, lettuce and other salad plants may still be sown.

FLOWER GARDEN.—Keep the surface of the land well stirred. Do not always stir to the same depth, otherwise you are liable to form a "hard pan" or caked surface beneath the loose soil. Alternate light with deep hoeings. A few annuals may still be planted, such as balsams, calendulas, cosmos, coreopsis, marigold, nasturtium, portulacca, zinnia, and cockscomb. Plant out whatever amaranthus may be ready. These may still be sown in boxes. Clear away all annuals which have done flowering. Bulbs should have all the dead leaves cut away, but the green leaves should not be touched. Stake chrysanthemums, and as the flower buds develop give them weak liquid manure. Coleus may now be planted and propagated from cuttings. Dahlias are in various stages, but the greater part will have been planted by this time. Give them liquid manure, and never let them dry up. Lift narcissus about the end of the year, but do not store them. Plant them out at once in their new positions. Top dress all lawns.

Orchard Notes for December.

By ALBERT H. BENSON, M.R.A.C.

THE SOUTHERN COAST DISTRICTS.

December is somewhat of an off month for pines, though bananas should be improving both in quality and quantity. The purely tropical summer-ripening fruits are not yet ready, and, consequently, there is only a limited supply of fruit in this part of Queensland during the month.

Early ripening varieties of grapes will mature, and care should be taken to market them in good order. The first fruit to ripen should be put up in small packages, as, if marketed in this manner, it will fetch a better price; but as it becomes more plentiful it can be packed in larger cases.

Pay particular attention during the month to all peaches, apples, pears, Japanese plums, or other fruits that are liable to be attacked by fruit fly, and see that no fly-infested fruits are allowed to lie about under the trees, and thus breed out a great crop of flies that will be ready to destroy the grape and mango crops as they mature.

If the month is dry, see that the orchard is kept well worked so as to retain moisture in the soil, and, in any case, even should there be a good rainfall, it is necessary to cultivate in order to keep down weed growth, as if weeds are not kept in check now there is little chance of their being kept in hand once the January and February rains set in.

The planting out of pineapples, bananas, and most kinds of tropical fruits can be carried out during the month, especially if there is any rainy weather; but, if the weather is dry, it is better to defer the planting of tropical fruits till January or February.

The cyaniding of citrus trees can be continued where necessary, and where Maori or orange mite is showing it should be checked at once, as Maori fruit is of no use for the Southern markets, and is unsuitable for export to the old country.

THE TROPICAL FRUIT DISTRICTS.

Clean up all orchards, pineapple, and banana plantations as long as you have the chance of fine weather, so as to have your land in good order when the wet season commences, as once the rain sets in there is little chance of fighting weeds. Watch bananas carefully for fly, and market the fruit in good order. Handle the crop of pines carefully; don't let the fruit get too ripe, as an over-ripe Northern pine is tasteless. The fruit should be cut as soon as it is fully grown, as even when quite green the rough-leaved varieties have usually developed sufficient sugar to suit most persons' taste. Pack carefully to prevent bruising, and they will carry South in good order.

Only send high-class mangoes South; bad flavoured sorts and stringy, caroty, or turpentine-flavoured varieties are not worth shipping. High-class fruit will pay to handle carefully, but there is no demand for rubbish, and I am sorry to say that fully 90 per cent. of the mangoes grown in the State must be classed under the latter heading.

Tropical fruits of all kinds can be set out during suitable weather. Fruit pests of all sorts must be systematically fought.

THE SOUTHERN AND CENTRAL TABLELANDS.

December is a busy month for the growers in the Stanthorpe district. Early apples, plums, peaches, nectarines, &c., will ripen during the month, and must be marketed as soon as ripe, as they do not keep long once they are gathered. Handle carefully and grade better. There is far too much early rubbish slumped on to the local markets, which tends to spoil the demand as well as the price. Watch the orchards very carefully for codling moth and fruit fly, and take every possible precaution to keep these pests in check should they make their appearance, as the future cleanliness of the orchard depends very largely on the care that is taken now to keep these pests in check.

If the month is dry, keep the orchard and vineyard well cultivated. Watch the vines carefully so as to detect the first signs of oidium or anthracnose, and systematically fight these pests, remembering always that in this case prevention is better than cure, and that only prompt action is of the slightest value.

On the Darling Downs every care must be taken to keep the fruit fly in check, and on no account must infested fruit be allowed to lie about under the trees, as this is far and away the best method of propagating the pest wholesale.

In the Central District the grape crop will ripen during the month. Handle the fruit carefully. Cut it when dry, and where it has to be sent long distances to market pack in 6-lb. baskets rather than in larger cases. When dry keep the orchard and vineyard well cultivated, and when the citrus and other fruit trees require it give them an irrigation. Don't irrigate grapes once the seeds have been formed, as it tends to deteriorate the quality, and to make the fruit tender, and consequently to carry badly.

Agriculture.

SILOS.

By H. C. QUODLING, Agricultural Insp ctor.

The class of silo referred to as "Portable and Non-Corrosive" has been put on the market by J. H. Holloway and Co., of Cromwell Buildings, Melbourne.

It is a patent steel-framed silo, with vertical sections from 9 to 12 ft. by 6 ft. in width; these are bolted together vertically and horizontally, and joints are lapped and packed. The studding is of angle steel, bolted at either end to angle-steel arcs. The inside sheeting is of 24-gauge galvanised iron, which is protected with an acid-proof mixture. Fencing wire is used to twitch round silo at intervals of a foot, to assist in withstanding pressure. The net cash prices, f.o.b. Brisbane, without roof, for silos up to 68 tons capacity, reckoned as for heavy silage, are as follow:—

(SILOS ARE SUPPLIED UP TO 150 TONS CAPACITY.)

| Capacity—Tons. | Sections. | Height in Feet. | Diameter in Feet. | Weight in Cwt. | Without Roof. | Elevators. |
|----------------|-----------------------|-----------------|-------------------|----------------|---------------|--------------|
| 12 | 5 | 9 | 9 | 8½ | £ s.
25 10 | £ s.
7 15 |
| 24 | 5-9' }
5-9' } 10 | 18 | 9 | 12½ | 39 10 | 10 15 |
| 28 | 6-12' }
6-12' } 12 | 12 | 11' 9" | 10 | 36 10 | 8 15 |
| 50 | 9-12' }
9-12' } 12 | 12 | 16' 9" | 15 | 47 10 | 8 15 |
| 53 | 6-12' }
6-9' } 12 | 21 | 12 | 18 | 50 0 | 10 15 |
| 55 | 7-9' }
7-9' } 14 | 18 | 13 | 20 | 52 0 | 10 15 |
| 61 | 7-12' }
7-9' } 14 | 21 | 13 | 21 | 57 0 | 10 15 |
| 68 | 6-9' }
6-9' } 18 | 27 | 12 | 25 | 61 10 | 12 15 |

Different classes of silos have been erected at the Queensland Agricultural College and the State Farms, to determine which class is likely to prove the most durable and economical for the farmer.

Briefly, the kinds in use are—

Rectangular Overground Silo (with fixed gable-ended roof).—Frame of silo is of 6 in. by 2 in. hardwood studding, lined horizontally and vertically with 6 in. by 1 in. tongued and grooved hardwood, the tongues and grooves being treated with hot tar or other bituminous solution before cramping up, followed by two coats of the same material, ports being left at convenient intervals.

Rectangular Overground Silo (with movable roof, to roll off).—Framework is similar to one previously mentioned, but corner posts are rabbited to receive 6 in. by 1½ in. tongued and grooved lining, treated as before, and then lined with 2-ply malthoid.

Fibro-cement Silo (120 tons capacity, 24 ft. high).—This kind is built of stout timber; octagonal-shaped framework, with hardwood battens checked in flush to form a backing for sheets of fibro-cement, with which building is lined. The frame is stayed by means of bolts placed at intervals where sections meet, and the whole building is clamped securely together by means of three iron rods passed around it at regular intervals. The joints formed where the sheets of fibro-cement meet, are pointed up to make air-tight with a cement mastic.

Circular Silos, of 60 tons capacity, timber studding, lined with 24-gauge galvanised iron, and protected with an acid-proof paint and a limewash when filling. (This is the type erected by the Victorian Government.)

Circular Silos, of 60 and 100 tons capacity, timber studding, and lined horizontally with 4 in. by $\frac{5}{8}$ in. shot-edged hardwood, to which an inner lining of 2-ply malthoid is attached.

Pit Silos, made by excavating in soil and rock underneath the roof of a hay shed, also makeshift silos made by excavating a deep trench with a plough and scoop, and afterwards using the soil removed from it for weighting material, and as a means, when rounded off, for keeping contents dry.

It has been ascertained by practical test that silos lined with galvanised iron, even when protected with an acid-proof paint and whitewashed, are likely to corrode should the silage be of a very succulent nature—as sorghums—and have to remain in the silo for any lengthened period, say, eighteen months at a stretch.

They may be filled with a crop which is not too juicy, as barley and other cereals, and emptied, say, in a few months, without any apparent change taking place in the galvanised iron.

As far as strength of construction goes, the circular, timber-lined silo is to be commended, but, so far, the inner and necessary air-tight lining of malthoid has not proved to be as good an acid-resister as it is claimed to be by the vendors.

Fibro-cement as a lining is somewhat brittle and easily damaged, but the manufacturers are putting a thicker sheeting on the market, to overcome this defect. Good silage has been made in this class of silo, with a minimum of waste at the sides.

The plain timber sheeting on rectangular silos acts for several seasons, but requires to be kept well protected, to save the absorption of juices which would rot it.

The tests which the galvanised iron lined silos have been put to have proved conclusively that it will be a fallacy to depend upon this class of lining to last any definite time. Steps have been taken to adopt a permanent lining, by simply using the galvanised iron as a background for a cow-hair and concrete plaster, 1 in. in thickness, applied to wire netting. The netting is previously attached to studs in the framework of building by means of staples, and forms a reinforcement for the plaster and a handy means of binding it.

With regard to the best type of silo to adopt, a decision has been arrived at to erect permanent structures of reinforced concrete. The material for reinforcement is Johnson's steel wire lattice, and consists of parallel wires about 3 in. apart, with vertical wires at regular intervals. The lattice may be had in any lengths and of any wire gauge.

Moulds to suit the circumference of the silo to be erected are made, and the wire lattice is embedded in the concrete used to fill them. Plans have been prepared for three silos, and next week a silo will be started at the Roma State Farm.

The cost of erection cannot be stated as yet, but once the moulds are made, which may be used for an indefinite number of silos of the same size, it is calculated the cost will amount to about £1 per ton capacity. The building, when complete, will be of a permanent character, unaffected by the weather or the corrosive action of the silage juices.

Department of Agriculture and Stock,
Brisbane, 15th October, 1908.

DRY FARMING IN SEMI-ARID DISTRICTS.

By W. FRANK McCLURE.

A great deal of attention is being attracted at this time to a system of agriculture known as "dry farming," which is being successfully used in the semi-arid districts of Colorado and other Western States in place of extensive schemes of irrigation. By "semi-arid" is meant a territory in which the annual rainfall is less than 20 and more than 8 in. By dry farming, many thousands of acres which, on account of their location, could never be reached by irrigation ditches, are reclaimed. Some of this acreage has long been styled "grazing lands," and considered useful for nothing else.

"Dry farming," briefly stated, consists in so preparing the soil in semi-arid regions that it will catch what little annual rainfall there is, and store it within reach of the roots of the plants to be grown. This, as might be supposed, requires a firm, solid foundation beneath the soil. The soil above is kept firm and loose, and acts as a mulch, keeping the moisture from escaping into the atmosphere, much as a brick or plank keeps the ground directly under it moist even in a beating sun. With such preparation of the soil, grazing lands will often yield as high as 40 to 50 bushels of wheat to the acre, or more than the yield of the Eastern States, where the natural rainfall is adequate.

The last two years have witnessed the greatest progress in the new plan of reclamation. Not only is "dry farming" being extensively employed in Colorado, Kansas, and Nebraska, where it was first introduced, but in eastern Washington, Oregon, Wyoming, Idaho, and Utah, where heretofore great tracts of prairie land could, in many instances, be bought as low as 50 cents an acre.

The first experiments in this line date back more than a decade. The founder of the method is Prof. H. W. Campbell, of Nebraska, under whose personal direction to-day are some large model farms in the West, illustrating the marvellous accomplishments of "dry farming." Five years ago the Department of Agriculture began to lend its assistance in the matter, carrying on investigations as to the localities in which "dry farming" will bring the best results. The department is also searching in many parts of the world for kinds of alfalfa and wheat and other plants which will yield the largest returns with a rainfall of less than 20 in.

As to land, it may be stated that high plateaux or rolling hills afford a better supply of rain to be stored by "dry farming" methods than do the valleys, and they are, therefore, usually chosen first.

The accompanying photographs were made at Longmont, Colorado, where many thousands of acres are under cultivation. This State is taking particular interest in development along these lines. Within the past year Gov. McDonald called together a congress of "dry farmers." Many ranches are being broken up to give place to the new system of farming, for it does not pay to raise cattle at the present prices at which this land is selling. In fact, much of the upland country is being turned into a veritable garden.

The first operation in the preparation of the soil is ploughing. This must be deep. A disc or a mould-board plough may be used, depending on the character of the ground. One object of the deep ploughing is to provide an adequate reservoir for the storage of the rainfall. Gang ploughs, with twelve to sixteen ploughshares in each, are a common sight. These ploughs are drawn by traction engines, as shown in the photograph.

Steam ploughing helps out wonderfully in this work. In some of the Western States it would be out of the question to secure sufficient men and teams to accomplish the ploughing of the hundreds of thousands of acres annually being reclaimed by "dry farming." Steam ploughing costs less than half as much as ploughing with teams. It is not unusual for one ploughing outfit to turn 3,000 acres of sod into cultivated land in one season. Two men are needed to operate the engine, besides a teamster and team for hauling fuel.

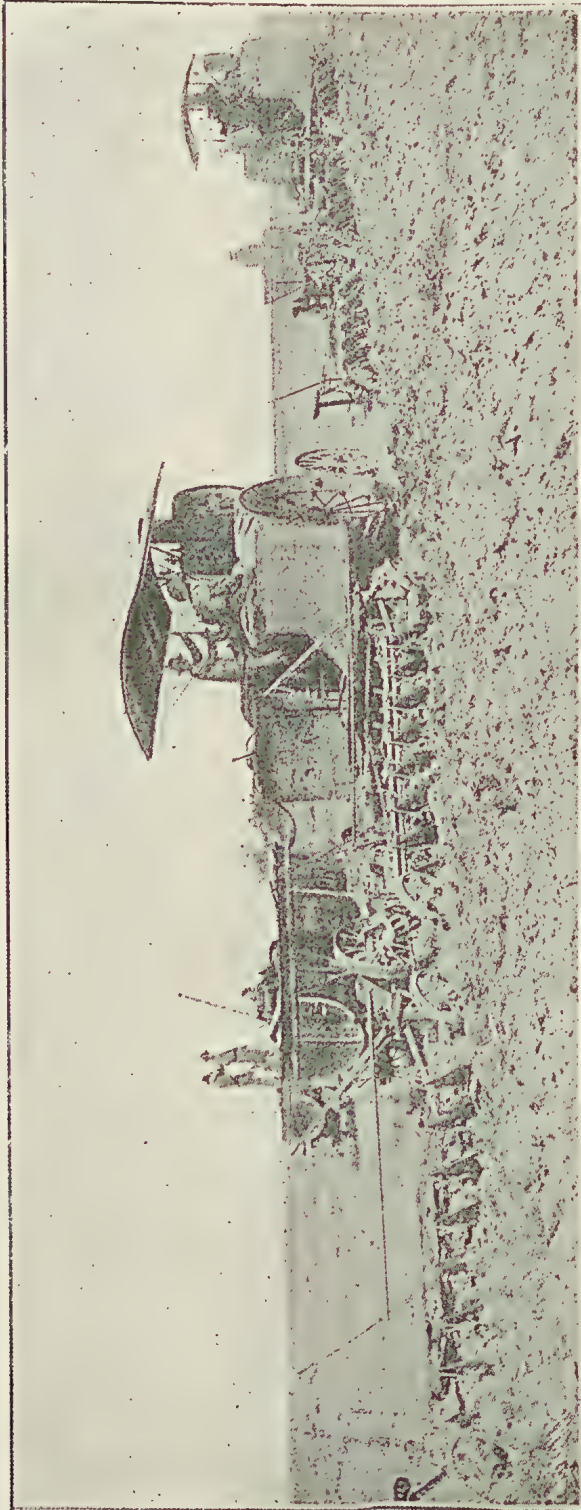

BREAKING THE GROUND FOR DRY FARMING.



DRY FARMING IN ARID DISTRICTS.—HAULING GRAIN TO MARKET IN COLORADO.

A sub-surface packer follows the plough, drawn by the same traction engine as the plough. This packer is similar in shape to a disc plough, except that it has ten wheels. These wedge-shaped wheels or discs are 18 in. in diameter, and are arranged vertically on a shaft 6 in. apart. The object of the sub-surface packer is to firm the soil. A smooth roller, if used for this purpose, would have the effect of packing the surface soil rather than that of the sub-surface. The wheels of the packer, however, are so arranged that they firm the soil in the lower portions of the furrow, restoring capillarity where ploughing has arrested it. A smoothing harrow next follows, leaving a pulverised layer on top, which prevents the moisture from below from reaching the surface and evaporating.

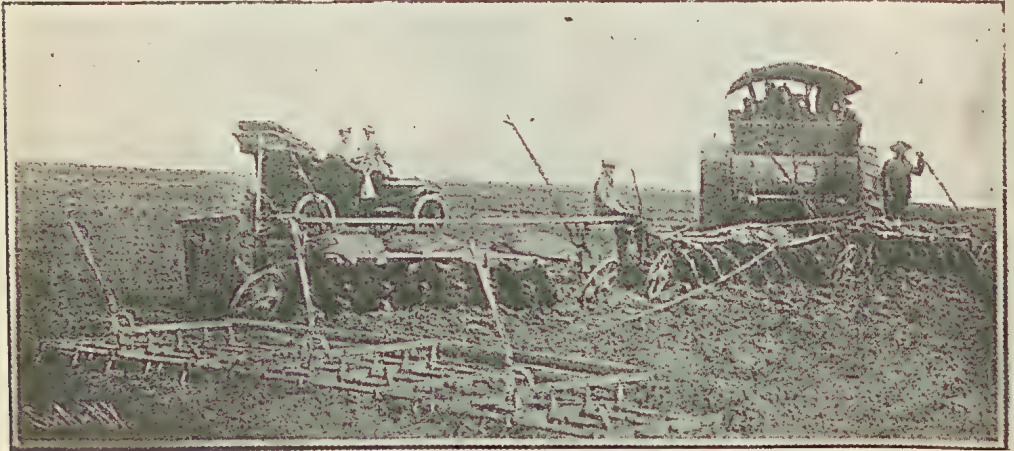

THE SMOOTHING HARROW FOLLOWING THE PLOUGH.

The constant care and working of the soil on which the crops are to be raised are said to be equally important with the rainfall itself. The pulverised ground must not be allowed to pack or break in any event. To avoid this, the harrow is run over it after each rain. The working of the soil begins several months before seeding, and must also be continued after seeding.

A great many people, cultivating their land under the new system, aim to raise but one crop from the same ground in two years. They divide this land into two equal parts, and use one part for crops one year, and the other the next. This admits of what is known as "summer culture" on the part not in use, and the storing of a season's rains in the soil reservoir. Again, it may be feasible to allow the land to produce crops for two years, and alternate one year of "summer culture." Where crops are planted every year, ploughing must quickly follow the operation of harvesting, the aim being to save all possible moisture in the ground and simultaneously prepare the soil for the next rains.

It is confidently expected that the time will come, when land on which but a 10-in. rainfall is now recorded, will be made to blossom as the rose. This will be accomplished by further advances in scientific discovery. At present, districts having less than 14 in. rainfall are not regarded as profitable. An educational movement for the scientific study of "dry farming" has already been talked of. Not all attempts at "dry farming" are a success, nor will be, until the mass of the people using it understand the principles on which it must be carried out. The rainfall varies in different years, and this emergency must be met in a scientific way. Conditions differ also in different localities.

The establishment of more Government experiment stations will greatly assist different sections. Several are to be established, it is understood, this year. At Cheyenne, Wyoming, the Board of Trade not long ago established an experiment station, assisted by the Government and the railroads. It was here found that, although Cheyenne is at an elevation of 6,000 ft. above sea level, wheat, rye, barley, oats, alfalfa, field peas, and sugar beets can be grown profitably. As a result of the experiments, the ranchmen in Wyoming are buying thousands of dollars' worth of farming machinery, and are breaking up large acreages and sowing alfalfa and other grasses and grains. Ranches are also being sold for colonisation purposes.—“Scientific American.”

JERUSALEM MAIZE.

We have, on several occasions, been asked for the seed of the Jerusalem maize, but none appears to be obtainable in Queensland, although in 1898 seed was obtained by the Department of Agriculture and Stock, and distributed to several farmers at Park Ridge, Redland Bay, Swan Creek, Warwick, Pittsworth, Wallumbilla, and Waterford.

We have just received a Bulletin (No. 1, April, 1906) on this cereal, issued by the Secretary for Agriculture, Chihuahua, Mexico, from which we extract the following information:—

“Jerusalem maize is a plant which should be propagated in Mexico, especially in regions where there is a small rainfall, because it is one of the few plants capable of producing a remunerative crop where maize and wheat perish for want of rain. Its capacity for resisting drought, which has on many occasions been proved, does not justify, however, the belief that it will yield a crop in any region wheresoever, where maize cannot be cultivated for want of water.

“We must look upon the plant merely as more resistant than maize, but not as a marvellous plant capable of yielding a crop in places where vegetation is impossible. In the arid regions of California it is sown in order to obtain a second crop, when there is no probability of obtaining one with ordinary maize.

“For several years this plant has been grown in Ciudad Juarez, and, seeing that, whether it is used as a fodder plant or because of some inevitable law which presents difficulties at the beginning of all business, or of all agricultural operations which effect their ruin, the fact remains that the results do not indicate that it concerns an unimportant article of cultivation for ourselves.”

The Bulletin alluding to experiments with Jerusalem maize says further:—

“The first sowing was made on 5th May, 1905, and the second on 20th June.

“The isolated sowing proved the precocity of the plant, which recommends it very much as a forage plant for cutting in a green state.

“We are equally convinced of its hardiness, because we intentionally left a small piece of ground without weeding, on a clayey soil, and without giving it the benefit of any labour, except ordinary irrigation, yet, notwithstanding this intentional neglect of care, the seed matured well, producing, however, as is natural, ears of less size than those of the plants on cultivated plots.

“The cultivation of these two plots places us in a position to institute comparisons with other crops which grew in contiguous fields.

“We are alluding to a field where already a crop of green barley fodder had been raised, which was sown on 24th December of the previous year, so that the soil had already yielded a crop after that year.

“The fields of Jerusalem maize thrive to perfection, and, according to observations made, it may be authoritatively stated that this plant is more

resistant to dry conditions than ordinary maize; and, furthermore, its qualities, which were generally recognised, are confirmed by experiments made in the United States.

“When the plant flowers, the ear inclines downwards in consequence of the weight of the grain, probably the result of heredity, as does the Egyptian Dourrha, which is another variety of heavily-seeding sorghum, and in the distinctive manner of the sugar sorghum, broom millet, and the common forage sorghum.

“After the flowering season, the ears of the Jerusalem maize appear perfectly formed, and inclined downwards, in consequence of the weight of the grain, which appears abundantly.

“On the land where the experiments were made in the cultivation of this plant, there appeared a black fungus (smut ?) amongst the maize, owing possibly to the peculiar climatic conditions, and here a curious phenomenon was observed: The ears of sweet cane or sugar sorghum suffered general contagion, producing blackened and ill-formed grains, 40 per cent. of the ears being thus damaged.

“In the fields *adjoining the Jerusalem maize, not a single ear was found to be attacked*, which proves that even under the conditions in which the experiments were made the Jerusalem maize was a plant immune to this disease. Without further experiments or more extended research, it would not be justifiable to generalise the affirmation that the disease does not attack this plant; yet there is already sufficient evidence to determine the above results concerning its resistance against the disease.

“Another singular phenomenon may be here noted, which tends to recommend Jerusalem maize as a field crop, of settled characteristics, well adapted to our climate and soil. In the sweet sorghum, whose seed (var. Early Amber), as is well known, is covered with black glumes, a hybridisation, very nearly general, which results in its ears producing a much more voluminous grain than the pure plant, grain which, owing to its size and shape, surpasses the original, a trait inherited by Jerusalem maize, the colour of which is a mixture of the black of the sweet sorghum and the pure white of the other seed.

“It is difficult to distinguish the hybrid of the sugar-cane and the brown dourrha of Egypt, for in the change there is not a single ear of Jerusalem maize which degenerates or suffers by the crossing, and all the grain saved exhibits the same qualities as those of the seed sown—viz., weight, size, and white colour.

“Both ordinary maize and Jerusalem maize are harvested during the first week in September, as in the case of sweet sorghum and others, notwithstanding that moisture may have been wanting during the growing season, and one may notice the vigour with which the roots of the two varieties sprout again, and in a short time produce a profitable forage crop.

“The Jerusalem maize harvest may take place before the abovementioned time, but a characteristic attributed to it should be noted, and that is, the ramification of the stems producing numerous ears, once each cane has produced the first ear. In effect, the product, notwithstanding its more reduced size, as compared with the first ears, will be less, as might be expected.

“As a result of this observation, it may be affirmed that the Jerusalem maize may serve in this climate to profitably occupy land on which barley or oats have been grown for green forage, and result at an opportune time in an excellent crop of grain and more leaf than ordinary maize.

“By making the sowing earlier, and not on land which has been under barley, a crop of grain may be obtained with certainty, or at least one cut of green fodder.

“Probably the aftermath, after the second cutting, provided moisture is not wanting, and if no early frost occurs, may likewise be profitable.

"The cultivation is done just as in the case of ordinary maize, except that it is sown in drills, depositing the seed at less depth. Sowing may be made at the same time, whether a green crop or a grain crop is required; in the latter case, however, there will be little profit.

"When the Jerusalem maize has germinated, the weeds must be kept down as often as necessary—*i.e.*, scarifying must be done as often as necessary to kill the weeds and to keep the surface of the soil in good tilth. After irrigation or heavy rains, the soil becomes compact, and forms cracks, which cause rapid evaporation. Then the cultivator must be used, a weeder or a scarifier to break down the crust and produce a fine surface, which will retain the moisture in the soil.

"This work must not be too deep, because Jerusalem maize, like ordinary maize, produces superficial, lateral roots, the destruction of which will injure the plant. . . . The furrows must run north and south, except in such localities where the slope of the land demands other treatment. . . . According to the analysis made at the Experiment Station in California, Jerusalem maize contains:—

| | | | | | | |
|---------------|-----|-----|-----|-----|-------|-----------|
| Water | ... | ... | ... | ... | 11.89 | per cent. |
| Ash | ... | ... | ... | ... | 1.87 | „ |
| Protein | ... | ... | ... | ... | 9.84 | „ |
| Fibre | ... | ... | ... | ... | 1.51 | „ |
| Free nitrogen | ... | ... | ... | ... | 71.16 | „ |
| Fat | ... | ... | ... | ... | 3.73 | „ |

100.00 per cent."

BUNT, OR STINKING SMUT OF WHEAT.

Press Bulletin No. 28, issued by the University of Nebraska Agricultural Experiment Station, U.S.A., deals with Bunt, or Stinking Smut of Wheat, by F. D. Heald.

Wheat (says Mr. Heald) is affected by two different types of smut: The loose smut, which destroys the entire head, transforming it into a powdery mass of black spores; bunt, or stinking smut, which affects only the berry, the other parts of the head remaining practically normal. There are two different species of bunt prevalent, but both affect the wheat in the same way, and they can only be separated by a microscopic examination of the spores. Nearly all of the bunt reported has proved to be *Tilletia foetans*, the smooth-spored species, while *Tilletia tritici*, the rough-spored species, has been exceedingly rare.

PREVALENCE.

The bunt of wheat has been especially abundant in certain sections of the State during the past season. From the number and character of the inquiries received it is apparent that the true nature of the disease and the preventive measures that should be employed are not well known by the farmers and grain dealers of the State.

Bunt has affected not only varieties of spring wheat, but it has been very prevalent in a large portion of the State where winter wheat varieties are grown. Almost all of the samples received from south of the Platte River were of the Turkish Red variety, while the majority of samples from north of the Platte were spring wheat. Turkish Red wheat has generally been considered especially smut-resistant, but the reports indicate that it will be necessary to treat seed of this variety for prevention of smut as well as in the case of spring wheat varieties. No samples of smutted wheat have been obtained from the eastern part of the State, but it has probably been present in small quantity.

EXTENT OF INJURY.

In some cases the smut has caused only a slight loss, while in others the loss has been serious. One correspondent reports, "Much wheat was too badly smutted for milling purposes." Another correspondent reported a loss of 15 cents per bushel on sale price, without mentioning the added loss from reduction of yield.

SYMPTOMS.

Bunt, or stinking smut, is not as noticeable in the field as the forms of loose smut, since it does not completely destroy the head. Its presence in a field may be detected by the characteristic odour, by the deeper green of the affected heads, and generally by the fact that the glumes are more spreading than in normal heads. A closer examination will show in the place of the "normal" kernels the black smut "berries" of nearly the same shape covered with a thin membrane. A small smut-eating beetle is quite frequently present on the affected heads.

The smut may be very noticeable in the threshed grain or comparatively inconspicuous. In some cases the smut berries (Fig. 3, b) are entirely broken up and the black powdery mass of spores which they contain is scattered and lodged upon the surface of the normal grains. These spores collect particularly in the groove and in the tuft of hairs or "brush" at the tip of the grain. Badly-smutted wheat is frequently dark-coloured owing to the large number of spores collected upon the surface of the normal grains. When the smut berries are not broken they can easily be detected by their darker colour, their plumper form with the obliteration of the groove, and the fact that they can be easily crushed so as to exhibit the black powdery interior (Fig. 3, d).

LIFE HISTORY OF THE FUNGUS.

Every spore which finds lodgment upon the surface of a grain of wheat is capable of reproducing the disease, and it is from these spores that the infection of the young wheat plant takes place. For this reason any seed treatment which will kill the spores of the smut without injuring the vitality of the wheat will be effective. Under normal conditions, the smut spores germinate soon after the young wheat seedling has started to grow. The spore produces a short, septate filament which forms one or more tufts of H-shaped sporidia. These sporidia either give rise to secondary oval sporidia (Fig. 3, g) or produce infection threads direct which penetrate the tissues of the young seedling. After the smut fungus has gained an entrance into the seedling it grows upward through the tissues of the stem, but gives little external indication of its presence until the heads are produced, when it penetrates the berries or kernels and forms the characteristic smut "berries" which have been described. All of the heads produced by an infected stool are smutted, and generally all the berries of a smutted head are destroyed.

PREVENTION.

By seed treatment, the bunt of wheat and the smuts of oats can be almost entirely prevented, while the per cent. of smut in barley, sorghum, and rye can be very greatly lessened. While the hot-water treatment is effective, it is a rather laborious treatment to employ. The result is that it has been very largely superseded in this country by some of the chemical treatments. The principle of the chemical treatment is to use a poison which will kill the spores of the smut and not materially injure the germinating power of the seed. Out of many different chemicals tried up to this time, only a part has proven effective, such as potassium sulphide, corrosive sublimate, copper sulphate or bluestone, and formalin. During the past few years the use of formalin has very greatly increased, and the satisfactory results obtained justify its continued use.

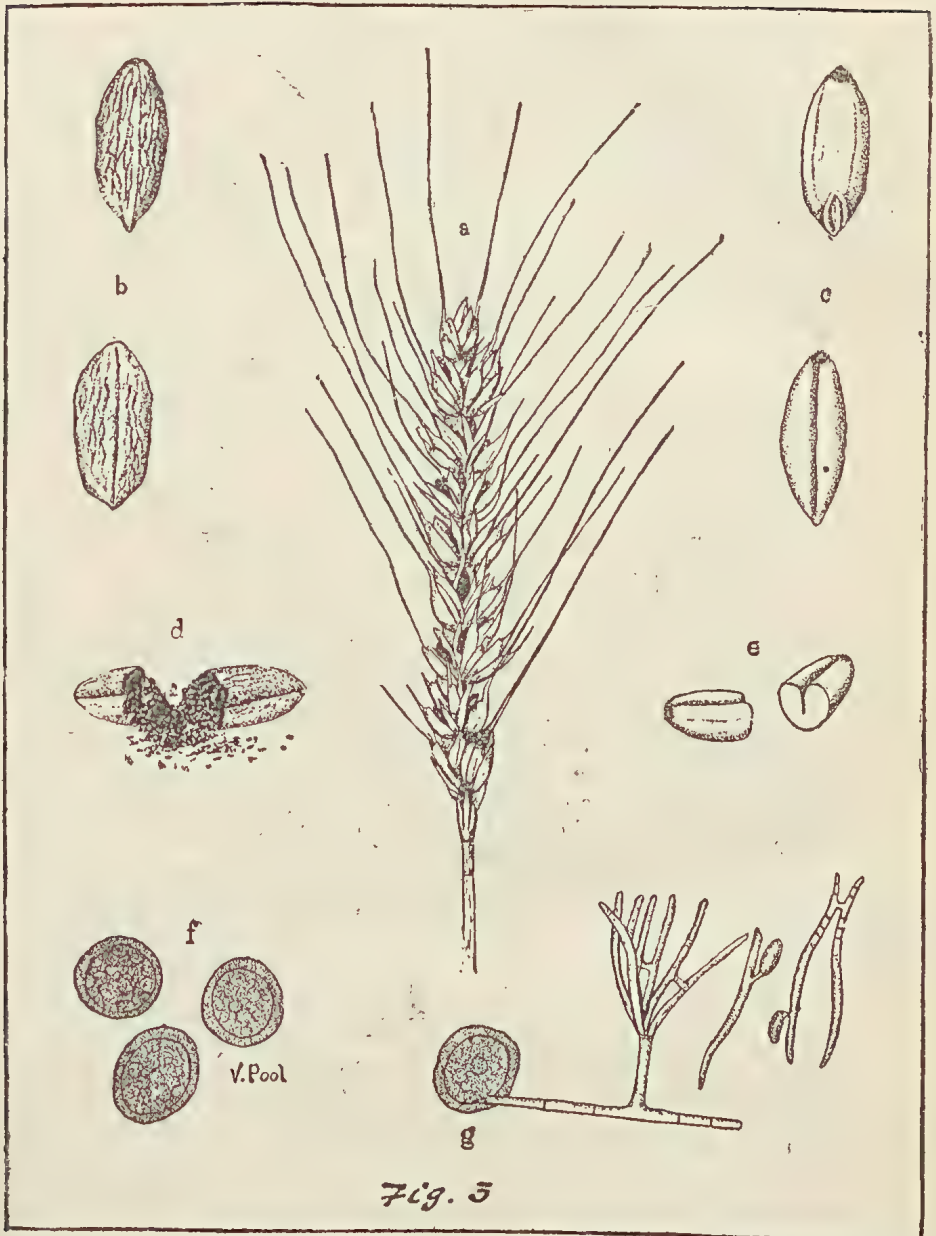

Since the formalin steep is generally successful and easy to employ, it may be especially recommended. Formalin is a solution of formaldehyde, and the commercial article is 40 per cent. This strength is always understood in recommending the amount to be used in seed treatment.

The treatment of seed may be carried out as follows:—

1. Place the seed to be treated upon the clean floor of the granary, or upon a canvas in the open, or in some other suitable place.
2. Prepare the solution of formalin by adding the commercial article to water in the following proportions: 1 pint to 30 gallons for bunt of wheat or loose smut of oats; and 1 pint to 20 gallons for barley or sorghum smuts. This solution should not be made up until it is needed for use, as it loses strength by standing.

3. Sprinkle the formalin solution over the seed, and shovel it over until the surface of each grain is thoroughly moistened. For sprinkling the seed, a common gardening watering pot may be used to good advantage.
4. Shovel the grain into a heap and cover with a canvas or wet sacks to prevent the evaporation of the formalin.
5. At the end of two hours, uncover and spread the grain out to dry. It will probably be necessary to rake or shovel the grain over several times to dry sufficiently to prevent germination. If treated in the granary, the floor should be sterilised with formalin solution before beginning operations. If the grain is to be returned to the same bin which it occupied before treatment, the bin should be sprayed or washed with formalin solution to prevent any reinfection taking place. For the same reason infected sacks should be avoided or sterilised.

The formalin treatment may be carried out in a slightly different way, and some may prefer it to the method already outlined. The writer has found the following method very satisfactory:—

1. Prepare a solution of formalin of the strength indicated.
2. Put sufficient of the solution into a barrel to immerse a sack of seed (35 to 40 gallons).
3. Put seed to be treated into sacks ($1\frac{1}{2}$ to 2 bushels), and dip each sack into the solution, allowing it to remain ten minutes.
4. Remove the sack and drain, allowing the excess of the steep to run back into the barrel. The solution should be replenished as often as necessary. The dipping can be very easily carried out by arranging the barrel so that a block and tackle can be employed for raising and lowering the sacks.
5. Set away in the wet sacks for two hours, or empty in a heap and cover with canvas or wet sacks as in the previous treatment.
6. At the end of two hours spread out to dry, taking pains to shovel over often enough to prevent germination.

Seed treated by either of the methods mentioned may be sown as soon as dry, or it may be stored in any suitable place if care is taken to avoid any reinfection.

CABBAGE APHIS.

Complaint having been received of damage to growing cabbage by aphid in several parts of Southern Queensland, a report dealing with methods for subduing it, prepared by the Government Entomologist, Mr. Henry Tryon, is being issued by the Department of Agriculture and Stock. It reads as under:—

With regard to the means to be adopted for keeping aphid occurring upon cabbage in subjection, it may, prior to going into details, be pointed out, that its mode of feeding consists in piercing the plant tissue with its proboscis or snout—an hair-like organ—and therefrom extracting the sap, and that, accordingly, unlike an insect that feeds by gnawing away the substance of the foliage, it must be attacked by means of some preparation that kills by contact. Such insecticides as Paris green, lead arsenite, &c., are not, therefore, available for its destruction. But, being a soft-bodied insect, the death of the individual may be readily effected; several preparations, when used, securing this end. Amongst these the following may be mentioned:—

1. *Tobacco Tea*.—Made by pouring boiling water over tobacco at the rate of 1 lb. of the latter to 4 gallons (kerosene tin full) of the former. Any crude tobacco being applicable for the purpose, such as leaves from ordinary plants grown on the farm and dried, or stalks, a waste product from tobacco manufacture. Should a little

syrup (crude molasses) or soap be added to the decoction, this will promote adhesion, always difficult in the case of cabbage aphids, and the plants they feed upon, both being covered with a wax-like bloom that tends to shed any fluid directed upon them. Generally speaking, this tobacco infusion should be of a strength indicated by its being of the colour of the beverage—tea. (*Note.*—Formerly one of the local firms, Fenwick and Co., Brisbane, stocked a convenient extract of tobacco named Roseleaf, wherewith readily to make the aphicidal “Tea,” and would possibly do so again were it in demand.)

2. *Fish Oil Soap Wash.*—Made by dissolving the soap in hot water at the rate of 1 lb. to 125 gallons (final dilution). (*Note.*—Fish-oil soap, or whale-oil soap, may be obtained from P. Frankel and Co., Edward street, Brisbane.)
3. *Pyrethrum* (“Insectbane” Powder) *and Water.*—At the rate of 2 tablespoonfuls in a bucketful of water, the powder being first made into a paste with a little water.
4. *Kerosene Emulsion.*—One pint in from 20 to 25 parts of water. (*Note.*—For manufacturing this and the undermentioned, see any modern work on horticultural practice—*e.g.*, Mr. A. H. Benson’s excellent work on spraying, furnished, on application, by the Department of Agriculture and Stock.)
5. *Resin Compound.*—One part of resin saponified in 12 or 15 gallons of water.
6. *Hot Soap Suds.*—Cabbage plants will tolerate water, especially when this is applied in the form of a spray that is sufficiently high in temperature to be quite fatal to plant lice or aphides. In mentioning several remedies, one is actuated by the experience that the farmer often possesses one of a number of substances when he has not a single specified one.

In conclusion, it must be borne in mind when pursuing methods for the repression of these insects that only those that the insecticide comes in contact with are killed, although it may have a slightly repellent action for a few additional individuals; and that, therefore, seeing too that aphides, especially in early life, are small, it must be applied in a very fine state of division so as to reach everyone; in fact, in a mist-like form. This end can only be secured by the use of a proper spraying appliance that can so administer a fluid preparation.

Again, by reason of the great and rapid increase in their numbers in the course of their natural development, a few individual aphides, if suffered to remain alive, will soon give rise to a numerous host. Accordingly, treatment must not only be very thorough, but repeated as long as any living individuals are discernible.

It is the neglect of the occurrence of a few examples on young cabbage plants at the time they are planted that is usually the explanation of their subsequent appearance in immense numbers on the developing plants. Accordingly, immediately prior to the operation alluded to, the young cabbages should be dipped in one or other of the fluids mentioned, care being taken, however, lest the roots be at the same time brought in contact with it.

Generally speaking, what has been stated will apply to other kinds of aphids and their repression.

STACK ENSILAGE.

Amongst those who have experimented in making silage in the stack, opinions are diverse as to results. Some maintain that there is very little waste; whilst others say that from 1 to 2 ft. of the outside of the stack is useless as fodder, except when feed is very scarce. A practical experimenter

in New South Wales gives his experience, as follows, to the "Australian Field":—

"The evolution of our system came about in this way: It was found that the stack need not be high, and that when dead weight is to be used for pressure, the stack is better to be low. Excavated earth was found to be the best material for weighting, and by using an excavation for building the stack in, there was a further saving in the height to which the covering earth had to be elevated. An oblong tank was, therefore, made with plough and scoop 3 or 4 ft. deep, with sloping side, like an ordinary waterhole. In this the stack was built, and carried up to about 12 ft. above the surface. With shovels a layer of earth about 12 in. thick was built, and placed on the slightly rounded top. The stack sank to within about 2 ft. of the surface, and there was no waste. There was found to be no gain in having the 2 ft. of ensilage above the surface, and consequently in making these tank stacks we now carry them up only about 7 or 8 ft. There is then after settlement only the covering earth above the surface. This system is carried out in a dry district, where the soil absorbs all the rain, and there is no seepage to spoil the ensilage.

SOIL INOCULATION.

Professor Bottomley has recently been lecturing at King's College, London, on the results obtained by the use of bacteria for supplying nitrogen to soils deficient in that element. It is not long since great expectations were formed as to the possibility of increasing the fertility of the soil by this means, and it was even stated that a man could carry the manure needed for 5 acres of land in his waistcoat pocket. Of late, however, like many other projects, little has been heard of the matter. Professor Bottomley wished it to be understood that soil inoculation is not a universal panacea.

It simply meant adding nitrogen-fixing bacteria to the soil. Those bacteria were very delicate little things, and required very careful handling. They were not to be pitched out wholesale anywhere; the conditions must be suitable. The remarkable results obtained in America were in poor soil. Good soil did not respond to inoculation. The ideal soil for this purpose was soil poor in nitrogen. Soil which it did not pay to manure, or which it did not pay to farm, might be brought into cultivation so as to produce large crops if it were only looked after and provided with suitable bacteria. One of the most important facts brought out as the result of reports received was that the maturing of a crop was considerably hastened by soil inoculation, and that meant increased profits. Over and over again experimenters reported that they were growing their inoculated beans 3 weeks or a month earlier than their non-inoculated beans. One grower sent up his runner beans 6 weeks after the seed was put in, which was a thing never done before.

INTERESTING WHEAT-GROWING EXPERIMENT.

An experiment in wheat-growing, of great originality and much promise, is being made in Russia. The experiment (says "Australian Field") consists solely in the manner of cultivation. The author of the new method is General Levitsky, who began last August in a little model farm adjoining his barracks. He sows single grains of wheat at the bottom of conical pits 1 ft. to 1½ ft. deep. As the grain thus sown in the apex of the pits begins to appear above the surface it is earthed over, and each time the leaf appears more earth is filled in till after, say, five or six earthings, the pit is full and level with the surface. The result of this treatment is that the plant, which has a "branching knot" at the base of the original stem, and of each new stem, sends out a number of new shoots at each starting. It is asserted in a letter to "The Novoe Vremya" that one grain treated in this way sent up 19,683 shoots. The straw seems to be unusually stout, the yield enormous, and General Levitsky believes that the plant will be perennial.

Dairying.

THE DAIRY HERD, QUEENSLAND AGRICULTURAL COLLEGE
GATTON.

RECORD OF COWS FOR MONTH OF OCTOBER, 1908.

| Number. | Cow's Name. | Breed. | Date of Calving. | Total | Average | Commer- | Remarks. |
|---------|-------------------|--------------------|------------------|-------|--------------------|-----------------|------------|
| | | | | Milk. | Test-
Per cent. | cial
Butter. | |
| | | | | Lb. | | Lb. | |
| 1 | Peewee ... | Holstein-Sh'rth'rn | 20 May, 1908 | 791 | 3·7 | 32·56 | |
| 2 | Burton's
Fancy | Shorthorn ... | 6 Sept. " | 621 | 4·5 | 31·41 | First calf |
| 3 | Grace ... | " ... | 20 May " | 630 | 4·0 | 28·16 | |
| 4 | Len ... | Ayrshire ... | 22 Sept. " | 724 | 3·5 | 28·09 | |
| 5 | Ethel ... | Grade Holstein ... | 3 Sept. " | 652 | 3·7 | 27·03 | |
| 6 | Carrie ... | Jersey ... | 16 Jan. " | 543 | 4·3 | 26·24 | |
| 7 | Hettie ... | Ayrshire-Sh'rth'n | 20 Mar. " | 502 | 4·5 | 25·39 | |
| 8 | Remit ... | Grade Holstein ... | 6 Aug. " | 648 | 3·5 | 25·15 | |
| 9 | Rhoda ... | " Shorthorn | 28 Mar. " | 600 | 3·7 | 24·7 | |
| 10 | Sue ... | " " | 25 May " | 636 | 3·5 | 24·68 | |
| 11 | Glen ... | Shorthorn ... | 10 Feb. " | 378 | 5·4 | 23·37 | |
| 12 | Nettle ... | " ... | 14 May " | 609 | 3·4 | 22·92 | |
| 13 | Ruby ... | Ayrshire ... | 21 July " | 536 | 3·6 | 22·47 | |
| 14 | Winnie ... | Shorthorn ... | 8 April " | 538 | 3·5 | 21·52 | |
| 15 | Lark ... | Ayrshire ... | 6 June " | 523 | 3·7 | 21·52 | First calf |
| 16 | Lubra ... | Grade Holstein... | 5 June " | 488 | 3·9 | 21·23 | |
| 17 | Night ... | " " ... | 5 Oct. " | 644 | 3·0 | 21·2 | " " |
| 18 | Cocoa ... | Jersey .. | 10 Nov., 1907 | 496 | 3·6 | 20·8 | |
| 19 | Mona ... | Grade Holstein... | 20 Oct. " | 521 | 3·5 | 20·6 | |
| 20 | Nancy ... | " Guernsey | 7 May, 1908 | 516 | 3·6 | 20·6 | First calf |
| 21 | Lady Loch | Ayrshire ... | 21 June " | 513 | 3·5 | 19·9 | " " |
| 22 | Lily ... | " ... | 2 May " | 506 | 3·5 | 19·64 | |
| 23 | Lalla ... | Grade Holstein... | 28 July " | 471 | 3·7 | 19·39 | First calf |
| 24 | Madge ... | " " ... | 16 June " | 443 | 3·9 | 19·28 | " " |

TREATMENT OF CALVES.

Little calves are like children. Early learned habits are remembered, and if you spoil your heifer you will have a spoiled cow. Never abuse calves, but make pets of them; let them have confidence in you. Train the little calves properly, and you will have a herd that will be a source of satisfaction and revenue to you.

ANGORA GOATS.

The mohair industry is gradually increasing in Queensland, there being at present, as far as is known, 4,589 angora goats in the State. The industry is still in its infancy, however, the production of mohair having only risen from 1,216 lb. in 1904 to 3,073 lb. in 1907, whilst the skins sold numbered 996 in the latter year as against 208 in 1904. One thousand and twenty-eight goats were killed for meat. Many of the grade animals are of a very poor type, and, as yet, few of the owners understand the subject of the production of marketable mohair, keeping the goats mainly for milk and meat, yet hoping to secure a further marketable commodity in the shape of mohair, without

extra care or trouble. We have repeatedly published articles, with illustrations on the subject of rearing angoras for mohair, in which minute details have been given, but apparently without great results.

In America and in South Africa it has been found that the angora goat of perfectly pure blood is much less hardy than other breeds, and its delicacy led the farmers in those countries, who embarked in the industry, to cross their imported angoras with local stock, as has also been done in this State.

The result has been to increase the size and strengthen the constitution, and also to raise greatly its mohair-producing capacity. It has been claimed for some of the best South African goats that they will shear as much as 20 lb. to 21 lb. each year, the average of the very best herds of goats being put at 11 lb. per head, whereas the pure-bred goat yields an average of 8 lb. only. This increased yield, however, has been obtained at the expense of quality; it is coarser than the hair of the pure-bred goat. The average American cross-bred angora is a poor creature; the imported stock was crossed with common Mexican goats, and the result is a light yield of mohair of coarse quality.

THE GORGONZOLA CHEESE TRADE.

A commission has been sitting at Milan to study, on behalf of the Italian Ministry of Agriculture, the results of the use of baritine (which contains sulphate of barium) in the manufacture of the crust of gorgonzola cheese. On this subject an American Consular report states that the Conseil d'Hygiene of France recently prohibited the importation of gorgonzola cheese on the ground that the sulphate of barium used in the crust might be injurious to health. As France is second only to England in the amount of gorgonzola consumed, it is of great importance to Italy not to lose the French market. At the present moment there is an especially good opportunity for gorgonzola cheese in France, because of the high price of roquefort, a cheese which so resembles gorgonzola that the two appeal to the same class of consumers. The commission have, therefore, lost no time in investigating the questions: (1) Is sulphate of barium injurious to the health when used to form the crust of cheese? (2) Supposing it to be non-injurious, are there no other substances which can be used with equal advantage and without giving rise to objections? The first question is answered in the negative. Sulphate of barium is innocuous, because it is insoluble, even in acids. There is indeed the bare possibility that some of the other salts which make up baritine might penetrate the crust and ultimately soak into a portion of the cheese; but such an event must be very rare, and the amount of salts which would be consumed in the cheese must be infinitesimal. Sulphate of barium, however, is not merely innocuous; it is unnecessary. It is not used in all gorgonzola cheese, but principally in the cheese destined for the world market, and especially during the summer months. Equally effective for the formation and preservation of the crust are a number of substances, such as various kinds of white clay, powdered talc, brick dust, &c. The commission recommends the adoption by Italian exporters of one of these substitutes for baritine, in order to remove every hindrance to the free development of the export trade. Experiments have already been undertaken by the chief producers of gorgonzola cheese, who are affected by the rejection of their shipments by the French Customs authorities at Modane. It is expected that they will soon find a means of making the crust of their cheese with some substance other than baritine, without imperilling thereby its durability for purposes of transportation.—“London Chamber of Commerce Journal.”

The Horse.

THE USE OF SAWDUST IN STABLES.

Not infrequently sawdust is made use of in stables as bedding material, and it undoubtedly answers very well for this purpose. It is true, of course, that this product of the sawmills is not by any means the equal of straw in this respect, which latter, after all is said and done, is the best and indeed an ideal kind of litter for use in the stable, but despite its general inferiority to straw as litter, sawdust nevertheless proves very useful in this direction. The outstanding feature of sawdust, in so far as regards its suitability for littering-down purposes in stables, is the fact that it possesses great absorptive powers for liquid, and in this particular respect it ranks considerably above straw. Whereas the absorptive capacity for liquid of straw amounts to only about two and a quarter times of its own weight, sawdust—provided it is perfectly dry—is capable of absorbing liquid to the extent of about four times its own weight. Thus, thanks to its great absorptive capacity, sawdust makes both a dry and a cleanly bed. It does not, it need hardly be said, afford such a soft bed for horses as straw litter, but still they are quite comfortable on it, provided the sawdust is put down sufficiently thickly.

Besides possessing great absorptive powers, sawdust also has certain deodorising properties, which fact considerably enhances its value and usefulness as a bedding material for use in stables. From a hygienic point of view it is certainly in every way excellent, it being absorptive, cleanly, deodorising, and cool to the feet. Those who have never used sawdust as bedding material in the stable may perhaps think that it is not particularly cleanly, but practical experience of it will soon prove to anyone who has any doubt about it that there is no cleaner kind of litter than sawdust. It is true, of course, that when the horse lies down on a bed of sawdust particles of the latter adhere to its coat or to its clothing, while some is also apt to adhere to the horse's legs, but it can be easily brushed off, and there is certainly no reason why sawdust should be objected to as a bedding material on this account.

The principal advantage which sawdust possesses as bedding material consists in its cheapness, and the fact that it can be obtained at a low cost is the chief and generally the sole reason why it is used in stables in preference to straw or peat moss litter. In stables where it is essential to observe the most rigid economy, the use of sawdust is certainly to be recommended, since a considerable saving can be effected by using it instead of straw. Sawdust cannot, however, be readily or cheaply obtained everywhere. It is available at a low cost only in some cases, and particularly in the neighbourhood of sawmills. Sometimes a supply of sawdust can be obtained from a sawmill practically for the asking, it merely being necessary to fetch it away.

Broadly speaking, it may be said that in bedding down horses with sawdust a little over 1 cwt. will serve a horse standing in a stall for a week. When a horse is quartered in a loose-box a correspondingly larger quantity per week will be required. Of course, when the supply is very plentiful, more than the above-mentioned weekly amount can with advantage be used, and a deeper bed be put down, thus rendering the latter all the more comfortable for the horse; 1 cwt. per week may be looked upon as being the minimum quantity of sawdust which is necessary in order to keep a horse comfortably bedded down, but if a larger quantity is available, so much the better. When sawdust is used as litter in a stable, the best method of management to adopt in regard to the keeping clean and renewal of the bedding is as follows:—First thing in the morning, after the stable is opened, all droppings, as well as all wet portions of the bedding, should be removed with the stable-shovel and

manure-skep, the holes which are made being subsequently filled up with fresh sawdust. The bedding should then be levelled, and this is best done by raking it over with a rake; but, failing the latter, the levelling must be done as best it may be with the stable-fork. During the daytime all droppings should be removed as often as possible, and in the evening wet portions of the litter should again be removed and replaced with fresh sawdust, and the whole properly levelled down. In this way sawdust bedding can easily be kept in good order and perfectly sweet and clean for a considerable time. At frequent intervals—say, once every seven or ten days—the whole of the sawdust should be removed or piled up in a corner of the stall, so that the floor may air properly, and get dry if it is wet. So long as sawdust remains dry it can be continued to be used, but, once it is saturated with urine, it is no longer serviceable. In using sawdust for bedding-down purposes, the floor of the stall or loose-box should be covered with it to a depth of, at any rate, 4 in., that being the minimum depth which the bed ought to have if a horse is to lie comfortably on it, but by preference it should be made an inch or two deeper than that.

It is most important, when sawdust is used, that it should be perfectly dry, otherwise it is unsuitable for use in the stable, damp sawdust both being unwholesome and not possessing much absorptive capacity. Sawdust which is obtained from unseasoned and green wood is unsuitable for use as bedding material in the stable, because it is not properly dry, and therefore deficient in absorptive power. One great drawback connected with sawdust is that it makes a bad manure. It decomposes but very slowly in the ground, and it takes a long time ere it gets thoroughly incorporated with the soil. For this reason farmers look askance at manure made from sawdust, and do not care about using it. The only way to dispose of it is to give it away.—“Live Stock Journal.”

[Sawdust is plentiful and cheap in Queensland towns, but it is not favoured as bedding by any who utilise stable bedding as manure, the reason being that before decomposing it becomes mouldy and injurious to plant life.—Ed. “Q.A.J.”]

CLIPPING HORSES.

All clipped horses, says a writer in the “Farmer and Stock-breeder,” should be liberally fed on rich foods that handsomely maintain the caloric—keep up the heat of the system. To clip an ill-fed horse, already very chilly for want of corn, is an absolute cruelty that should not only be severely tabooed in all horse society, but should subject the owner to legal proceedings. In our very slowly advancing civilisation the sympathies of mankind stretch out beyond the narrow confines of humanity, and the man who is cruel to animals is nowhere tolerated. If he cannot feed liberally he cannot expect great exertion, and he should then leave all the coat on the horse.

WHERE TO LEAVE THE HAIR.

When well-fed horses are clipped it is a good plan to leave hair on the extremities, where the circulation may be sluggish, and also on parts of the body which are much worn by harness. In good, well-managed stables hunters keep the coat under the saddle and on the legs, and to this should be added a large part underneath, where the girths may wear away first the short-clipped hair and then the skin, and also between the fore legs and between the thighs. What object there can be in crawling under a horse to take away the very fine and fluffy growth which is the only protection of the delicate inside of his thighs I never could understand. It does not improve his appearance, as that part is not exposed to ordinary view. It forms no part of the *tout ensemble*, and the thin hair does not materially increase the perspiration, therefore there is no object in taking it off,

Poultry.

REARING TURKEYS.

The following points of primary importance in connection with the habits of turkeys were outlined in the "Australian Gardener," by Mr. H. V. Hawkins, Poultry Expert:—

In the first place, the Turks had little, if anything, to do with this breed, so that the name "Turkey" was not given this excellent table bird by them, but rather by the Americans. Personally, I am inclined to the belief that the Mexicans discovered the wild turkey, but the credit for vastly improving and domesticating it, and raising the breed to the present standard of perfection, rightly belongs to the Americans. In any case I am content to know that the Americans have farmed turkeys for so many years, and have wonderfully changed their type, colour, and habits, with such splendid results.

The question so often asked is, "Why turkey farming has been so long neglected here?" Those who have done most for the Commonwealth in this regard, have been the squatters, who, in many cases, merely have a few at first to supply a change of menu from mutton. They have little time to devote to the care of these birds, still, in most cases, the result is a great success. The reason is not difficult to find—*i.e.*, turkeys being great travellers and foragers, must have acres. They may be seen in large flocks in the Riverina, miles from the station homestead. They have a decided objection to being fed on wheat morning and evening. I have taken particular notice of their method of feeding, and have invariably found that they had good appetites when variety of food abounded—*i.e.*, first a seed, then an insect; possibly a grasshopper would cross their track, and a bad time the grasshopper would get when a flock of 200 bronze turkeys set sail.

BEST BREEDS TO FARM.

The bronze turkey being large, and the flesh so beautifully white and succulent, is perhaps the breed *par excellence*, yet it should be always borne in mind that the 40-lb. gobbler is not the most profitable to breed. Birds of 14 and 18 lb. weight are usually those which consumers prefer, provided sufficient flesh is presented to the chef by which he can satisfy a fairly large number of visitors. The black turkey gobbler of good size, and 2 years at least, and unrelated, and twelve or thirteen large bronze hens (2 years old), make an ideal breeding flock. Many add a very large bronze gobbler, which is unsuitable for the hens, non-fertilisation of eggs being the result. Each hen averages eighteen to twenty eggs before going broody.

Turkeys need little attention if kept away from fowls and ducks. Turkey farming pays best by itself, and the northern areas are more suitable than the southern. They lay their eggs in a secluded spot; a cement barrel laid on its side with a brick each side to prevent rolling, and a branch of a tree partially covering its entrance, is all they want to encourage them. It is best to permit the eggs to remain in the nest. The hen is usually very cautious on entering and leaving her nest, and seldom breaks an egg, unless she has not had sufficient shell formers in her diet. See that she gets ample cinders, burnt bones, and charcoal, and, when possible, plenty of dry oyster shell. Much depends on the farmer whether she breaks the egg and hatches her young.

MAKING NESTS, ETC.

Always provide the hen with an inviting spot and plenty of green grass for the nest; a too dry nest often causes trouble—lack of moisture. In districts in the far north I have strongly urged that one side of the barrel be

removed; make the nest on the ground, oval in shape, and keep a fair amount of moisture around the nest. Give the hen opportunity to dust herself in a damp spot; she will get it if possible, and there will be little fear of dead chickens in the shell unless breeding from immature birds is practised. A gobbler at 12 months is not the best. He should be at least 2 years old; likewise the hens. Above all, introduce fresh blood every second year; this is of great importance in the raising of turkeys for profit. Again, a vigorous gobbler will fertilise all the eggs of a dozen hens in less than 4 weeks—that is to say, suppose a turkey hen, after she has had the companionship of her mate for say a month, lays seventeen eggs at a stretch, the whole batch laid prior to her brooding will be fertilised. In short, you need only borrow a good gobbler for one month in the season, provided you are not hatching late chicks. See that his toes are not like a razor, otherwise serious results may follow; I have, this season, stitched three beautiful bronze hens, the backs of which had been laid bare.

Of one thing there can be no doubt, turkeys do best in the fresh air, and will not stand coddling; they should be housed in large airy sheds, open completely on the eastern side, with perches fairly wide (3 to 4 in.). The straighter the breast bone, the better satisfied will the consuming public be, and narrow perches mean crooked breast bones. Do not place the perches too high, especially where the ground is hard or stony, as turkeys are, like fowls, subject to bumble feet, which often spoil hens for a whole season. I am quite convinced that turkeys must be encouraged to accustom themselves to shed roosts; they prefer the limb of a tree or the top of a harvester, but that should not be. A little coaxing for a week, a kindly bucket of oats by way of encouragement, will do much to form the habit of coming home each night at dusk instead of their straying away, or being found in the field in the morning with their heads off—the work of native cats, which are very troublesome in some districts.

FEEDING TURKEYS.

The adult birds usually find most of their own food, yet it is an absolute necessity to feed the flocks when natural foods are not available—*i.e.*, in autumn and winter they get down in condition if not attended to, although they have unlimited range. Insect life is then scarce, grass is of poor quality, and is also usually wet, and the consequence is they scour and often die from the effects. Barley meal, maize meal, and bran (one part each), with a fair amount of chopped-up boiled rabbit, and when available a few sliced-up raw onions, all mixed with the soup in which the rabbit or other animal food has been boiled, should be used. Mix as dry as possible; turkeys do not thrive on slops. Curded milk is much relished, and is a splendid flesh former, and a whitener of flesh; nothing is more objectionable than a fatty breast. Too much maize feeding, or a constant supply of wheat, will not improve the colour of the flesh. Oats are by far the best of the grains to assist in keeping down fat.

Fresh Water.—Always provide fresh clean water daily, and keep the vessel out of the sun; neglect in this regard will cause losses by disease. Add charcoal in case of bowel disorders; it is an absolute necessity in successful turkey raising.

Grit.—They must have an unlimited supply of grit, without which they suffer much from indigestion. Small pebbles, coarse sand, and pieces of broken crockery and smashed up burnt bone all aid in digesting their food; this is especially required prior to their going to roost.

Boiled Grain.—There is no necessity to boil any grain; they are better without it, and prefer the hard food to that of a sloppy nature.

Egg Producers.—The so-called “egg producers,” mentioned by some of my correspondents, would, if fed in sufficient quantities, in some cases assist egg production, but at what a cost? The best egg producer is insect life, and

when not available in sufficient quantities, add the best substitute—*i.e.*, beef and mutton scraps, sheep or bullock's liver, or rabbit, soaked in cold water overnight, and then lightly boiled. Use the liquid for mixing the morning meal and avoid making it pasty, but use the hands well in mixing hard and friable. Curded milk when available should be a magnificent aid to egg production, and when topping turkeys off for market, give them as much as they will take, as it softens and whitens the flesh; milk-fed turkeys eat like six weeks' old chickens.

Young Turkeys.—For young turkeys many successful raisers use hard-boiled eggs mixed with stale bread crumbs, and a little fine oatmeal, moistened with skim milk (crumbly, not sloppy). This is given the very young chicks for the first week, after which eggs should not be given, but plenty of finely-pulped raw onions added, and the milk curds, and a little dry bone meal and charcoal mixed well through. This not only keeps their bowels in order, but supplies the additional phosphoric acid necessary to quick growth of bone, and increases stamina, thus decreasing the chance of "leg weakness," a complaint to be guarded against. Encourage the very young turkeys to eat millet seed at night, and after 2 weeks feed on hulled oats for best results, until old enough to have a little wheat or oats.

Keep the young turkeys dry. Nothing kills sooner than long wet grass; once they get a soaking, death may be expected. Always keep them in confined pens, well sheltered from wind and rain. Do not on any account allow them on the dewy grass, but keep them in until the sun has dried the grass off a little. Examine all young poults for vermin, which is so troublesome at the back of the head and near the vent; hundreds of birds die through no other cause. The pest is similar in habits to the tick, holding on and penetrating the skull. The young birds should be freely dusted with insectibane, and a little carbolic paste applied at the back of the head. Neglect in this matter is the cause of many deaths. The fact that late hatches do not develop as fast as the early hatches is of importance to all farmers of poultry, be it turkeys, ducks, or fowls. The early chicks may be relied on to produce the best results. The longer a hen lays in a season, the more impoverished she becomes as a result of hard work. Thus we find the embryo becomes smaller and weaker, and if from these late poults we get bad symptoms, first catarrh, often the precursor to a more serious trouble—*i.e.*, roup, or, to make it clearer, a running at the nostrils is observed, and later, symptoms show a swollen head, from which arises an offensive smell.

Onion tops, dandelion, rape, and raw onion finely cut, and white clover, are without doubt the favourite green foods with turkeys; and they are rich in mineral salts, and valuable as correctors of blood. From 5 weeks old and on, this can be given mixed in the morning food (pollard, bran, &c.).

If the pasture has a variety of grass, so much the better, as they prefer variety, but if it be a dry droughty spot, sow lucerne in a 1-acre enclosure. After it becomes established, it will keep you supplied with green summer food, being rich in protein, and also an egg-producer.

Area.—One hundred adult turkeys could easily be run on 5 acres, but, unless you are compelled to fence, I would advise giving them full liberty, as they will not require so much feeding. It is rather difficult to say whether 3 ft. and three added wires on top will suffice to keep them in; much depends on the way they have been brought up. If at all wild 15 ft. would not keep them in without doctoring the wing joint.

Domesticated poults are usually tamer than Leghorns, and give less trouble in this respect. I would certainly recommend trying 3-ft. wire, with four plain ones above; but care should be taken when putting in posts. Do not use too thick a post, for this reason, that if the posts are "table-topped" they allow ample room for a gobbler to fly on to; the others will soon learn the habit.

The main thing in marketing is to top off and to grade the birds according to size, not putting three big gobblers in a crate with five or six wasters. Mark your crates first, second, and third quality, and you will be quite satisfied when account sales come in. Make the agent your friend, it creates confidence, and will do his best for you; the farmer who is always chopping and changing about makes a serious blunder. Keep in touch with your salesman; tell him how many birds you will have for disposal, and ask him to wire you when a scarcity of white flesh exists. Don't rush him with twenty crates when ten will suffice; the agent usually knows when to advise you to send, and the cost of a telegram often pays.

THE INSECT PEST.

One of the great and most important questions in poultry-keeping is the vermin question. These little pests swarm in some of the fowl-houses, and play sad havoc with birds of all kinds and ages—the weakest going first to the wall in the natural course of events. One little red bug we have long known as a terrible pest, but we have always found them congregating in large numbers in some hiding places, and then at night, when the birds are roosting, coming forth and sucking their blood as they perched and attempted to rest.

Lately they have been getting on the bodies of all sorts of birds, and not in solitary instances. We have been alarmed to discover how prevalent this evil has become, and so far as we have ever known this is an entirely new danger for poultry-keepers to meet.

We first discovered the presence of these pests on the bodies of fowls in the daytime when we were paying a visit to a large poultry-keeper's plant. The stock were out of sorts and ailing, and we began to examine everything as minutely as possible to find out what was the cause of the weakness of the birds, as some of them could scarcely walk.

We felt sure the birds were infested with vermin, and accordingly examined them carefully for lice, when upon turning aside the crest feathers we found even worse enemies in possession, for there we found thousands of these little red bugs literally massed upon the heads and up the quills of the feathers.

These little red bugs are very strong insects, although so small, and are very powerful antagonists when they are present in such numbers on fowls, and after this we found matters were pretty much the same in other instances, and we would warn poultry-keepers against what may prove a most damaging development of the insect question in poultry-keeping. Both cocks and hens seem to be attacked, and we found some beautiful Houdan stock cocks that were affected in the same way.

To remedy this state of things the greatest care must be taken to see that the perches are quite clean of these pests. We have often shown how the perches should be made to fit in sockets so that they may be examined and cleaned at the ends.

The great reason why this matter should receive immediate attention is that the winter laying is very largely dependent upon the preserved vitality of the fowls, and in seventeen out of twenty cases we are called upon to investigate in which fowls do not lay properly during the winter months we find the loss occasioned solely and simply through the ravages caused by insects that prey upon the fowls.

We have recommended burning up the old perches, and in cases where they are fixed they should be pulled out, and any bark-covered perches should be burned, and every part cleansed, so that it kills every one of the bugs. Were it not for small maggots or grubs that live on these red bugs, and turn

into a small light-brown moth, the case would be worse, as these keep the red bugs under in the old-fashioned fowl-houses.

Then as to the birds that are infested. Of course, these insects are not like fowl-lice; they are stronger ever so much, and to paraffin the birds is out of the question. Sometimes the insects eat right into the flesh in bad cases, and it is very essential that insect powder should not only be used freely, but care must be taken that the powder reaches right down to the skin where the insects are, so that they are killed, as the birds must stand a good deal of annoyance and pain where so dreadfully infested.

We have tried experiments, lasting over several days, to determine the best method of treatment, and the pyrethrum powder-kills them in from 7 to 10 minutes, although fowl-lice would not last as many seconds, and the specially-prepared insect powder, if the insects are covered, kills every one. Of course, when the insects collect in such large numbers upon the head, the skin must be well covered; but great care must be used to guard the eyes of the bird well, as the insect powder must not be allowed to get into them; as it would cause great pain.

After the head has been well dusted, the superfluous powder should be wiped off with a dry cloth. We trust our readers will examine their birds for these bugs, as we find that the bugs continue on the fowls' heads, and this year they have extended their operations to other points of the body, and prove an almost fatal pest to the birds.

The great secret in the career of most poultry-keepers, successful or unsuccessful, generally turns out to depend very much upon the amount of pains bestowed upon the minor details of management.—“Farm and Field.”

PREPARING FOWLS FOR SHOW.

At all Queensland shows, whether metropolitan or country, poultry form an interesting section amongst the exhibits, and it is to the interest of exhibitors to present their birds to the judges in the pink of perfection. A few hints on preparing them for exhibition will be of some use to the amateur exhibitor.

There are two chief points in preparing a bird for the show-room—First, quietness; and second, cleanliness. Good advice in this respect is that given by R. H. Crosby, in the “American Poultry Journal.” He says, in respect of the above two qualities:—

By quietness is meant birds that are easily handled, and will not be scared nearly to death when in a coop. The fancier can train his birds for the show just as a horse is trained for a race. Starting, say, a month before the show, the birds that are to be exhibited should be handled as much as possible, so as to get them good and tame. If the show specimens are placed in a coop at night, and fed in the morning before letting them out, they will soon become used to the coop. While shut up, they should be taken out of the coop and handled, just as a judge would handle them at a show. A short cane should be kept handy, and the bird taught to pose when touched with it. If this treatment is kept up, your birds will show up far better than your neighbours' birds that have not had such good preparation.

While your birds are showing themselves off to the best advantage, your friends' untrained birds are huddled up in the far end of the coop, and are afraid to stand up for inspection. Thus it will be seen that much is to be gained by training your birds for the show, for, even if your birds are not quite as good as the other fellow's, your specimens will show up far better than the other party's scared-to-death birds. Anyone who has ever visited a show knows that the above is perfectly true, and, while some birds were looking their best, some others would be found huddled up in the back end of the coop.



THE KELLERSTRASS WHITE ORPINGTON HEN VALUED AT £2,000.

In the second place, your birds must be clean from beak to toe, and most birds are the better for a good washing. Of course, if your birds are not white, and the plumage looks good and clean, then it is not advisable to wash them unless you understand the job from start to finish, for the writer remembers the mess he made of the first birds he attempted to wash. But most all white birds are better for a thorough washing. To successfully wash a bird, you will want three tubs. In tub No. 1 place clear warm water; in the second, warm water with a quantity of soap dissolved in it, and made into suds, and tub No. 3, containing warm water with a little bluing added. An assistant is necessary, for one person cannot manage alone very well. Now bring in your birds (you should borrow the kitchen for the job), and provide a light coop for them. Catch a bird, and, while your assistant holds it in the water of tub No. 1, you should thoroughly wet all the feathers. Be sure and have all the plumage well soaked. Now, squeeze out as much water as you can, and then place in tub No. 2. And now the real work commences. Take a bunch of feathers in one hand, and thoroughly wash them with the other. Don't be afraid of hurting the feathers, for a wet feather will stand a lot of rubbing. A tooth-brush should be used to clean the legs and feet, being sure to get all the dirt out of the cracks and corners. The water should be pressed out of the feathers as much as possible, and the bird is now put into No. 1 tub again, and all the soapy water rinsed out of the plumage. Now place your bird in the third tub, and be sure and get the blue-water thoroughly into the feathers. Press out as nearly dry as possible, and give the bird a toss up in the air to get the feathers loosened up, and then place in the coop to dry. Be sure you get the head and feet perfectly clean. Before sending or taking your birds to the show, rub up their legs with a soft cloth to which a little vaseline has been applied. The comb and the wattles should be treated in the same manner. If you don't wash the plumage, be sure and clean head and feet, for a bird with dirty legs and feet is not a nice specimen for a judge to handle, and he will give preference to the clean bird every time. In conclusion, I wish to say that I trust these few lines will be of some use to a new hand at the game.

A £2,000 HEN.

In June last we published an account of the sale of five white Orpingtons for £1,500. They were purchased from the Ernest Kellerstrass Poultry Farm, in Kansas, U.S.A., by Madame Padarewska, wife of the celebrated pianist Ignace Jan Padarewski. Mr. Fern, Poultry Expert to this Department, has furnished us with the illustration here reproduced of the mother of the above-mentioned five chicks, which the owner values at £2,000. He states that he is prepared to pay £2,000 for a "Crystal" White Orpington that will equal her in every way.

ZAPUPE FIBRE PLANT.

An article dealing with the rapid extension that has of late years taken place in the cultivation of the "zapupe" fibre plant in Mexico was given in the "Agricultural News" (Barbados) of 18th April last, page 125 (says that journal). Within a period of two or three years after the cultivation had started, no less than 4,000 or 5,000 acres were devoted to the growth of the fibre plants, and the industry is reported to be a remarkably remunerative one.

The specific identity of the "zapupe" has not yet been established, but, so far, it has been considered to be a species of Agave. In the course of an article contributed to the "Tropenpflanzer" of April last, however, Dr. Endlicher states that his observations lead him to believe that, as in the case of "ixtle," the "zapupe" fibre is probably produced from more than one species of plant, and it seems likely that the chief plant from which it is obtained belongs to the natural order Bromeliaceæ, and is not a species of Agave.

The Orchard.

A SUCCESSFUL BIRD-SCARER.

The following description of an ingenious appliance for scaring birds from fruit trees and seed beds is given in the November issue of the "Fruit World." The report of a gun, and especially a double report, suffices to drive away any kind of bird, and this invention, which relies upon loud detonations, deserves to be experimented with. We therefore willingly give it publicity in the Journal, in the hope that it may prove of service to some of our readers. The appliance may be obtained on application to The Farm and Dairy Machinery Company, 517 Collins street, Melbourne. The price, including 800 cannons and fuse, is £2 9s. 6d. The "Fruit World" writes:—This cheap and unique invention has already become a necessity to every orchardist. This is the first season that it has been placed on the market, and already growers are giving it great recommendation. In the Somerville district Mr. G. G. Cole, a prominent nurseryman and fruit-grower, has been experimenting with this Automatic Bird-scarer. By means of simple automatic mechanism large crackers, imitating gun-fire, are exploded at various intervals without any personal attention being required other than to charge the machine with supplies every one or two days as needed. Mr. Cole thinks that the invention is a great boon, and he has gone to considerable trouble to interview the Minister of Agriculture of Victoria to obtain permission for orchardists to store fireworks, and has been successful, the Commonwealth now allowing orchardists to store 200 lb. of fireworks on payment of 1s. license per annum. Mr. Cole says he expects good results as regards scaring the starling in particular, and fruit-growers have now a ready means of saving a very large portion of their crops of cherries, plums, pears, apples, &c., which are usually destroyed by birds.

This experiment of Mr. Cole's is undoubtedly one of the finest recommendations that the Automatic Bird-scarer could obtain, and is a recommendation

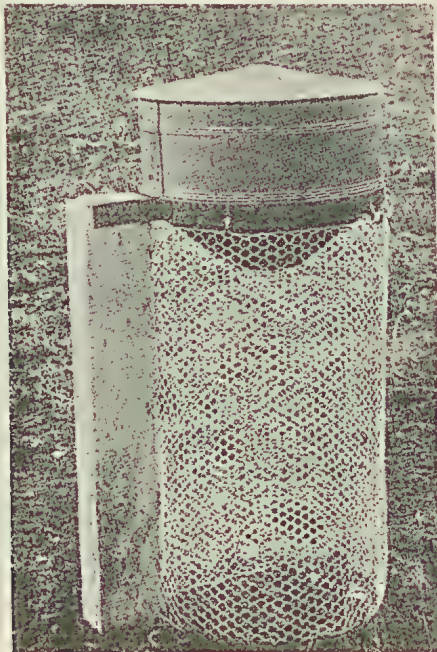

BIRD SCARER.—THE CASE CLOSED.

to every grower in Australia. Some of the prominent users in Victoria are Mr. Barnett, of Mildura; Mr. H. M. Sargood, of Macarthur; Mr. A. Hartwick, of Germantown; Mr. H. Gray, of Buln Buln, and others; and any growers who are adjacent to these can readily become acquainted with the invention. In New Zealand a large number of growers are using the scarer with great success. As one to four machines in every 10-acre lot will approximately save three-quarters of the fruit, the value of the small outlay in purchasing machines and crackers is considerable, and will give a big profit. Even if only twenty cases of fruit were saved in the 10 acres, it would pay the cost of the machines, and leave a considerable profit, so that our previous statement that every orchardist must use them if he requires to obtain more profitable returns, is a correct one.

Besides being useful in the orchard, it is of immense value in the field where seeds have been sown, or in large or small private gardens. Briefly described, it consists of a circular metal case, about 14 in. in width by 8 in. in depth, in the top end of which is fixed a spiral strip of iron, along which is arranged a series of hooks and forks, adapted to receive a length of slow-burning fuse and large cannon crackers, one or more of which can be suspended from each hook in such a way as to bring its fuse in contact with the slow fuse. The machine being charged, one end of the fuse is ignited and the cover closed.

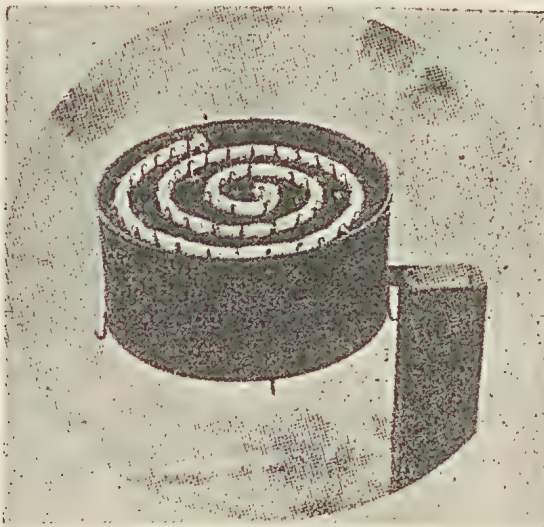

BIRD SCARER.—THE CASE OPENED.

As the slow fuse gradually burns away, it ignites each cracker in turn, causing a loud explosion every 15 or 20 minutes, or more or less often as desired, and will continue firing periodically for about 15 hours without further attention, and can also be set in the evening to begin firing off at any hour next morning.

Mr. Cole reports as follows:—"Dear Sirs,—With regard to Bird-scarer, I think it is the best I have seen so far. I have given the first one I got a thorough trial, and find it works very satisfactorily, so I have sent in another order. I am sure it does not run into more than 1s. per day at the outside, and the birds, I am confident, will never get used to it. A good point is that you can regulate it to have a double explosion now and then, and I find the birds do not like the guns at all. I have been a heavy loser by birds, and have tried everything to keep them away; but I feel sure that I have struck the right thing this time."

Botany.

CONTRIBUTIONS TO THE FLORA OF QUEENSLAND.

By F. MANSON BAILEY, F.L.S., Colonial Botanist.

Order CRUCIFERÆ.

SISYMBRIUM, Linn.

S. Irio, *Linn.* London Rocket. An erect hard-stemmed annual plant, 1 or more feet high, smooth. Leaves runcinately-pinnatifid; the lobes toothed, terminal one elongated. Flowers small, yellow, in erect racemes. Pods on more or less spreading pedicels, 2 or more inches long, slender, often all turned to one side.

Hab.: Europe, in waste places and roadsides, met with as a weed at Ipswich, *T. F. Hall*.

*RAPHANUS, Linn.

Sepals erect, subsaccate at the base. Stamens free, edentate; pod elongate tereta, continuate or moniliform, indehiscent, contracted between the seed, separated by a pithy substance filling the pod.

R. Raphanistrum, *Linn.* Wild Radish or Jointed Charlock. An erect or spreading annual or biennial, 1 to 2 feet high, much branched, and bearing stiff hairs on the thicker parts. Leaves pinnately lobed, the terminal segment large; rough with short hairs. Flowers; calyx very erect; petals either white with coloured veins or pale-yellow or lilac. Pod usually 1 to 1½ inches long, nearly cylindrical when fresh, and terminating in a long, pointed, or conical style when dry, often separating in joints between the seeds.

Hab.: Europe; often introduced with lucerne seed, and has become a farm weed.

Order BIXINEÆ.

COCHLOSPERMUM, Kunth.

In "Flora Australiensis," Bentham, referring to the fruit of *Cochlospermum Gregorii*, F. v. M., seems to have considered that the fruit described of this species in *Fragm. i.*, 71, belonged rather to *C. Gillivraei*—a conclusion which anyone might arrive at, as, from capsules I have just received from Mr. J. A. C. Wilson, of Croydon, I can find no mark by which the capsules of the two species can be distinguished the one from the other. The principal distinction is in the foliage—in *C. Gillivraei*, leaves palmately divided to within ¼ or ½ in. of the base into 5 or 7 lobes; *C. Gregorii*, leaves pedately divided to the base into 7 narrow-lanceolate segments. From the Croydon specimens, I should think this latter species was of a larger growth, and that the leaves were more abundant at the time of flowering.

Order LEGUMINOSÆ.

ACACIA, Willd.

A. purpureapetala, *Bail.*, "Queensl. Agri. Journal," XV., 780. To description add:—"Pod about 5 lines long, 3 lines broad, tapering towards each end and veined, the margins ciliate. Seeds disciform, dark-brown; funicle red, very short. The specimens, bearing pods, from Dr. T. L. Bancroft, Stannary Hills."

Order MYRTACEÆ.

EUCALYPTUS, Lhér.

E. stannariensis, *Bail. sp. nov.*; "Dead Finish." Said to form a handsome tree of about 100 ft. in height, with a diameter of 2 ft. at base of stem. Wood yellowish, considered of little value as a timber. Bark resembling somewhat that of the Moreton Bay Ash (*E. tessularis*); but it is more flaky and spongy, especially on the lower portion of the stem, and in this respect somewhat closely approaches in bark the Yellow Jacket of Paroo (*E. ochrophloia*)—"Yapunya" of the natives—the colour of the two barks being nearly alike. This kind of bark is said to cover the lower two-thirds of the trunk; the rest and branches have a yellowish naked appearance from the close smoothness of the bark. Branchlets slender, weeping, more or less purple or reddish and angular, but soon terete. Leaves 3 to 4½ in. long, 5 to 8 lines broad, falcate, oblique at the base and shortly tapering to slender coloured petioles of about 6 lines, much tapering above the middle to almost thread-like points; veins all fine, the oblique almost parallel ones rather close, reticulate ones forming a rather close network, intramarginal nerve rather distant from the edge. Oil dots scattered, rather large, not numerous. Panicles lateral, angular as well as the branches, umbels not numerous, usually of few flowers (1, 2, or 3), shortly but plainly pedicellate. Operculum thin, hemispherical, shorter than the calyx-tube. Calyx-tube not prominently veined or glossy. Stamens about 3 lines long, inflected in the bud; anther ovate-oblong with parallel cells. Ovary somewhat flat-topped, style nearly as long as the stamens, stigma not broader than the summit of the style. Fruit semiglobose, 4 lines diameter, scarcely or not contracted at the top, rim broad, convex, the valves slightly projecting, 3 rarely 4-celled. Seeds angular.

Hab.: Stannary Hills, *Dr. Thos. L. Bancroft*.

Dr. Bancroft tells me that the vernacular name is derived thus:—"Bushmen, when making a damper, found good cinders or coals could be obtained by burning pieces of this wood, but when the coals were raked about preliminary to placing the damper in the ashes they went out. As long as you left the fire alone it burnt well enough, but when interfered with went black."

Order ARALIACEÆ.

ASTROTRICHE, DC.

A. longifolia, *Benth.*, var. *glabrescens*, *Bail.* This only differs from the normal form in being of a glabrescent character.

Hab.: Moreton Island, Field Naturalists' Excursion.

Order COMPOSITÆ.

*CARTHAMUS, Linn.

Capitula homogamous; florets all fertile (rarely outer 1-seriate female or wanting.) Involucre ovoid or subglobose; bracts many-seriate, imbricate below, the outer or intermediate foliaceous and spinescent in wild forms. Receptacle plane, setose. Pappus more or less paleaceous, many-seriate, occasionally wanting. Thistle-like rigid herbs, with alternate spinose-pinnatifid or spinulose-serrate leaves, and terminal solitary or cymose, rather large, often fiercely involucreate, scarlet yellow whitish or rose capitula. Chiefly confined to the Mediterranean regions and Levant.

C. lanatus, *Linn. Sp. Pl.* Yellow Distaff-Thistle. An erect more or less pilose annual, simple below, 1½ to 2 feet high. Leaves spinous, 1 to 2 inches long, the upper ones sessile, acute, semi-amplexicaul, lanceolate; floral ones

similar.—*Kentrophyllum lanatum*, DC. This plant, like many of our other weeds is a stray from garden culture. Specimens of the above plant have been sent to me by Mr. J. T. Milson, shire clerk, of Winton, where, if not checked, it will likely prove an addition to our noxious weeds.

Order LORANTHACEÆ.

LORANTHUS, Linn.

L. tenuifolius, *Bail.*, Bot. Bull. XVI., 1, June, 1903. This specific name having been previously applied by Engler to a tropical African species of the genus, change to *L. Beauverdiana*, *Bail.*

Order EUPHORBIACEÆ.

PHYLLANTHUS, Linn.

P. urinaria, *Linn.*, Flora Austr. VI., 102. "Te-no" of Mapoon natives. An erect ascending or procumbent glabrous annual or perennial of 1 to 2 ft., with angular stems and numerous slender branchlets resembling pinnate leaves. Leaves distichous, narrow-oblong, nearly sessile, often all under $\frac{1}{4}$ in., but sometimes nearly $\frac{1}{2}$ in. long on the main stem. Stipules small, often bordered with white. Flowers minute, nearly sessile, the females solitary with or without 2 or 3 males, all turned to the lower side of the branch away from the leaves. Male perianth of 6 ovate or obovate segments, about $\frac{1}{4}$ line long. Anthers 3, distinct, erect on a column nearly as long as themselves, the cells parallel. Glands globular. Female perianth-segments narrower and more rigid than the males, about $\frac{1}{2}$ line long. Ovary 3-celled. Styles free, spreading, dilated and 2-lobed at the end. Capsulè depressed-globular, scarcely furrowed, scaly-tuberculate or almost muricate. Seeds more or less distinctly marked with transverse ridges or rows of tubercles. *P. echinatus*, *A. Cunn*, *Herb.*, *Benth.* l.c.

Hab.: Mapoon, *J. F. Bailey*; Stannary Hills, *Dr. T. L. Bancroft*.

DESTRUCTION OF RATS IN CANEFIELDS.

We have been asked to suggest a plan for destroying rats, which often cause havoc amongst the sugar-cane. Some years ago (1899) the late Mr. E. Long, of Habana Plantation, Mackay, adopted with much success the following plan:—As soon as the crop was off (as nothing can be done amongst full-grown cane) great slaughter was caused by laying baits of ripe cane; the cane being split into two or more pieces, 6 in. long, and saturated by dipping in a 2 per cent. solution of strychnine. As long as there was little new cane to be got, these baits proved an irresistible attraction to the rats; after the cane was up the rats were not so keen, and a new medium of bait had to be tried. The following was the most successful:—Green sweet potatoes sliced up into small pieces (the small tubers were mostly used), allowed to dry for twenty-four hours, and then, as with the cane bait, dipped in a 2 per cent. solution of strychnine. These were freely taken by the rats, of which large numbers were destroyed.

Another simple plan, said to be very effective, is worthy of trial: Dress plenty of bits of straw with strong birdlime, and spread these thickly on the ground around the burrows. Amongst the straws throw some attractive bait—barley or malt sprinkled with oil of carraway is a good draw. Next morning the straws will be found gathered up in little bundles, and in the centre of each will be found a rat, dead or alive.

Horticulture

FLOWER GARDENING, No. 11.

By THE EDITOR.

PLANTS SUITABLE FOR OUTDOOR CULTURE.

GODETIAS.

These are a very fine class of showy free-flowering annuals, well suited for beds and borders, their large, bright-coloured flowers rendering them very attractive. They have been called by some growers "Annual Azaleas."

VARIETIES.

Godetia gloriosa.—A very showy, dwarf, compact plant, with large, satiny, brilliant deep blood-red flowers. It is the darkest coloured of all the Godetias; Marchioness of Salisbury grows about a foot high, bears a profusion of very beautiful flowers, which are bright carmine-crimson, the petals having broad, clearly-defined light margins; Bijou-White, dark rose spot, dwarfest; the dense bushes bear innumerable flowers. The Bride, crimson and white; Duchess of Albany, when in full bloom, this resembles a miniature rhododendron, so profusely is it covered with its trusses of satiny-white flowers. Other beautiful varieties are—General Gordon, Mandarin, Princess Henry, Duke of Fife, Duke of York, Whitney, &c.

SALVIA.

Salvia is a large and widely-distributed genus of plants, including annual and biennial, perennial herbaceous and evergreen species. The salvia has been found in various parts of Europe, Asia, Africa, and America, some of the most ornamental species being natives of South and Central America. A number of the herbaceous species have been cultivated in Victoria, many of which were insignificant as ornamental plants, while others, as *S. azurea* and *patens*, are, on account of the beautiful shades of colour of their flowers, most worthy subjects.

The most popular salvia cultivated here is Bonfire, a garden variety specially valuable for its display of bright scarlet flowers during the summer and autumn months. Gloire de Stugdardt closely resembles Bonfire, being somewhat heavier in type of flower and habit of growth. Either kind is valuable for decoration of mixed groups, or for bedding purposes. The flowers do not last long on the bushes, but the calyx, which is about half an inch in length, is also bright scarlet, and lasts for a considerable time. There are several other shrubby kinds that are worthy of a place in the garden, being free-blooming plants, and of easy culture. The common sage, *S. officinalis*, is a member of this genus, and is not more hardy than several varieties grown for their flowers.

Most of the salvias will grow into nice bushes from 3 to 5 ft. in height, and flower well in any garden soil. Bonfire may be seen growing in the public gardens and nurseries in any part of the metropolitan district, thriving splendidly in the most widely different soils. If the plants are given a fair amount of water during the summer, and are sheltered from devastating winds, they will grow gracefully anywhere.

S. patens requires a cooler and more shaded position to attain perfection than any other kinds. It is one of the most beautiful of the genus, producing spikes of bright blue flowers. The variety is tuberous rooting, and is propagated by divisions of the tuberous roots in spring, or from cuttings of the

young shoots in a hothouse or hotbed frame. It produces seed freely, and young plants raised in spring in pots or boxes of soil placed in a cold frame will bloom during autumn.

S. azurea produces plants of a pale-blue colour, and will thrive under ordinary border treatment in almost any kind of soil. The habit of growth is loose and straggling, the plants requiring to be staked and trained as growth advances. Propagation is effected by division of the crowns in spring, the plants producing sucker-like growths like a chrysanthemum.

In many gardens salvias—Bonfire and Gloire de Studgardt—are treated as annuals, young plants being raised each season from seeds. The plants seed freely during the summer, and this method is undoubtedly the easiest. Seed should be sown for early planting in heated frames, for later in cold frames. The plants are cut down by frost in winter unless protected. The plants are watered sparingly during winter, and are placed in heat and started into growth early in spring: Cuttings of the young growths, about 2 in. long, are inserted in sandy soil and root readily, after which they are potted and kept growing and gradually hardened preparatory to being planted out in October and November. Such plants will bloom early in summer, successive plantings till early in January ensuring an abundance of bright flowers until winter. In places where frost is not severe the old plants will survive and break into growth near the base in spring. They may be pruned back to the young growth, and will make large plants during the summer, but, on the whole, young plants each season, whether from seeds or cuttings, are more satisfactory.

VARIETIES.

Other shrubby kinds worthy of culture are—Bethelli, bright rosy-pink flowers, tipped with white; Bruanti, scarlet; Hoveyi, dark purplish blue; *Grahami purpurea*, purplish crimson; *Rutilans*, magenta; and *Splendens*, scarlet. These are evergreen shrubs, that may be propagated from cuttings inserted in sandy soil in autumn. The *Salvia* thrives in our light soils, and will blossom until killed by severe frost.

ASTERS.

Asters are very showy plants for beds and borders; they bloom abundantly in almost any soil and situation, and cannot be surpassed for cut flowers. When well grown, nothing can exceed the chaste loveliness and exquisite colour blendings of a nicely-arranged bed of choice asters, and certainly no plant can be more easily raised and grown to perfection. They are half-hardy annuals, producing a profusion of bloom, in trusses of six to eight heads, of beautiful colours, stripes, and spots, 3 or 4 in. across. Light rich soil, with a mulching of manure suits them best. As a rule, asters should not be sown before September, and, to ensure a succession of fine blooms, further sowings may be made up to January. These latter, although they will not probably produce such fine blooms as those sown earlier, will be found exceedingly useful. As already stated, asters will thrive and flower in almost any good garden soil, but, if really fine blooms are required for exhibition, it is advisable to have the soil well broken up, and a good quantity of thoroughly-decayed manure worked in. The healthy growth of the plants and the development of fine blooms are greatly assisted by the occasional application of liquid manure up to the time of the plants showing the flower, when it should be discontinued. Seed may be sown in spring and autumn. They are the better for being transplanted. Give plenty of water during dry weather.

VARIETIES.

Surprise Aster; Sunlight, a fine yellow aster, attaining a height of 15 to 20 in., with flowers 3 to 4 in. in diameter; Ostrich Plume, Malmaison Rose, bears immense double flowers, 4 in. across, beautifully curled and twisted—

colour, white with pale-lilac; Victoria Dwarf; Mignon; Comet; Giant Emperor; Perennial, single large flowering; Lady in White; Imbricated Pompom; Pink Empress; Perfection, &c.

AMARANTHUS.

This is one of our most valuable annuals, which enlivens our gardens with a perpetual profusion of its ball-formed, purple, orange, and white blossoms. The Amaranaceæ are ornamental chiefly for their foliage and handsome habits of growth, which render them very striking in beds and masses. The leaves have a tropical appearance, gorgeous in crimson and gold, green and yellow, which deepen in the autumn. They are beautiful border plants, requiring plenty of room, good soil, and a warm position. They are hardy annuals, and should be sown in September, October, and November.

VARIETIES.

A. salicifolius has graceful leaves, shading to a bright orange-red; *A. tricolor* has long rose, yellow, and fiery-coloured leaves; of this variety *A. Queen Victoria* is a magnificent exponent; Firebrand, large leaves, deep blood-red, with bright yellow edges; grows to a height of 6 ft. *A. Henderii*, leaves carmine, orange-yellow, and green. *Gomphrena globosa*, Globe Amaranth.

POPPIES (*Papava*).

This magnificent family of plants includes some of the most lovely colours and shades to be found in the floral world. The Single Shirley, Iceland, and Tulip poppies are charming, and the double varieties are gorgeous in their colouring. They are easily cultivated. All they want is good soil and plenty of room. They should be planted in clumps during the spring where the plants are intended to remain, as they do not bear transplanting easily. The varieties of poppy, both as regards size and colour, are very numerous, bearing the names of Pæony, Ranunculus, and Carnation-flowered.

ORIENTAL POPPIES.

These great poppies are without doubt the most gorgeous of our early summer flowers. Their blooms, from 6 in. to 10 in. in diameter, are of a brilliant scarlet colour, and the large black blotch at the base of each petal, and the central mass of anthers, liberally supplied with pollen, that looks like deep-purple soot, make the scarlet petals appear still brighter when the flower is looked at closely; while a group of established plants, each plant well furnished with its flaming flowers, forms the most gorgeous spectacle that can be enjoyed in a garden, whether seen from afar or near. There are many cultivated varieties, differing in size, habit, and colour of flower. Some may be called a deep-orange, while in others the scarlet is softened in the direction of salmon colours, the buds when first showing colour being in this case of a very delicate salmon-pink. A group of five or more strong clumps makes a magnificent effect in a flower border. It is as well to cut away a good number of the weaker flower stems, as the plants always bear more than are needed. Unfortunately, they require staking; the great heads of flower are so heavy that the stalk, unless supported, is in danger of breaking down from the very root, but it is best to stake at only half their height—not only that less stake may be seen, but also that the upper half of the stalk may bend about at its own will, for though some stems grow well upright, a good number—and often those with the largest flowers—twist about with the slightest wind.

VARIETIES.

The Shirley, single and semi-double, with charming shades of pink, rose-margined, and veined; Mikado, double, pure white and scarlet; the petals are fringed. The Bride, the flowers are very large, pure white, and the petals

nearly entire at the base. It is very useful for cutting purposes, but the flowers must be cut as soon as barely expanded, and then they will stand for a considerable time. Victoria Cross, this is a magnificent variety, of a rich vermilion colour, with a pure white cross. Tulip Poppy, this variety rises to a height of 12 to 14 in., and produces, high above the foliage, fifty or sixty large and splendid flowers of a vivid scarlet. Other beautiful varieties are—The Peacock, Mephisto, White Iceland, Double French, Umbrosum, *Nudicaule aurantiacum*, &c.

ESCHSCHOLTZIA.

The Eschscholtzia is a very beautiful Californian annual. A very showy plant, with handsome, hoary-green, much divided foliage. It wants plenty of space, will thrive in any ordinary garden soil, and is very hardy. Sow in the autumn and spring where the plants are to remain, because, when transplanted, they are a very long time before they start growing again.

Californica, bright yellow; *Californica alba plena*, double white; Mandarin, scarlet, rich orange inside.

PORTULACCA.

There are many varieties of the Portulacca, both with single and double flowers. A bed of these plants, when in full blossom, may aptly be likened to a stained-glass window. Nothing in the garden can equal it in dazzling beauty and effect. The beauty of the bed is, however, of short duration, as the flowers do not open until about 10 o'clock, and close again about 2 in the afternoon.

The seed should be sown where the plants are to remain, and they do better in the open ground than in flower pots. If sown in spring and summer the seed will germinate, and the plants become strong and large, and of healthy growth before requiring to be watered, whereas in pots the soil soon dries, and the young plants on first germinating are either destroyed by drought from being left unwatered, or, if watered, by the force of the water as it issues from the watering-pot.

The best way of growing this delightful annual is to make one or more circular beds of a fine mellow soil, in a conspicuous and sunny situation, and having well watered them with a watering-pot, shortly afterwards sow the seed. Then cover the beds with grass or matting till the seeds germinate, and then remove it. The seed being extremely minute, a pinch of it should be mixed well in a teacupful of dry sand, and sprinkle the mixture by throwing pinch after pinch over the bed; thus it will not be sown unevenly or too thickly. After this, cover with a sprinkling of pure sand, and shelter as above stated.

VARIETIES.

Striata, white flowers, striped and spotted; *Aurea*, deep golden colours, dark throat, very handsome; *Grandiflora*, double, beautiful, variously-coloured flowers of a large size.

SALPIGLOSSIS.

A tall, erect-growing annual of exquisite beauty when in full blossom, with its numerous delicately-pencilled velvety flowers of the size and form of a thimble, and of various shades of colour. It is one of the best for cutting, either for bouquets or for table decoration. The colours of the flowers, which are single, range from golden to purplish crimson, veined and blotched with wonderful tints only to be found in the Salpiglossis. But the great feature of this beautiful genus is that its flowers, when cut, can be kept in water for four or five days, during which period they never lose their freshness or beauty. The dwarf varieties give beautiful flowers, very large, with a magnificent range of colours.

The Salpiglossis likes a rich, light soil. Sow in the spring, and prick out the plants when an inch or so high.

VARIETIES.

S. sinuata, *Variabilis grandiflora*, *Variabilis gr. superbissima*, *V. Nana*.

LOBELIAS.

The tall flowering Lobelias merit a higher place in flower gardens than is allotted to them at present. They are an elegant class of plant, both in style of growth and in the intense shades of colour. Some of the dark-leaved varieties are fine subjects for pot plants. They are free-blooming, hardy annuals, and make good basket plants, edgings, ribbon or carpet bedding, producing a dense carpet of bloom. There are some sixteen varieties in cultivation, yet we see very few of them in our gardens. Sow during autumn and spring. Plants from seed are far the best to grow for bedding purposes, but it requires rather nice management to get up a crop of seedling *Lobelia fulgens*. The seed comes best when sown on the surface of old leaf-mould, and just pressed down without any covering.

VARIETIES.

L. cardinalis: This, although a true Lobelia, is quite distinct from the annual varieties, and is a perennial. Spikes, tall; flowers, cardinal; leaves, bronze. It prefers a cold climate, and should, therefore, succeed in the cooler parts of the State. Emperor William, flowers dark rich blue; White Perfection, pure white; Victoria, a fine scarlet; Royal Purple, dark stalk, flowers deep-blue, with distinct white eyes; Double Blue, in this variety a proportion of the flowers are double.

NASTURTIUM.

This plant is so common in Queensland that it would seem needless to say much about it here. It is remarkably hardy, and will thrive in any soil without any care or attention. Its many forms are so varied that it possesses a pleasing variety of colour. The number of varieties is very great, producing flowers of a pale-straw colour, orange, scarlet, dark, rich, crimson-brown, and of every intermediate hue, spotted and striped. Dwarf varieties do not grow more than 9 in. high, and form compact bushes, flowering abundantly. They can be transplanted, and should stand 12 in. apart. The tall varieties will spread, or climb 15 ft. Sow in the autumn or spring.

Do not be stingy with the seeds, but plant where there is a place for them; have them in large beds, but do not plant in the shade.

It is a good idea to plant a number of seeds in the vegetable garden for cut flowers. There is nothing prettier than a large bowl of Nasturtiums; then, they are such a cheerful flower.

It is best to plant them in beds on the level with the surrounding surface, as the raised beds dry out so quickly; and I find best, unless one has some special provision for watering them, to have them where so much moisture will not be required.

VARIETIES.

(Dwarf.)

Empress of India, bright scarlet; King Theodore, darkest of all, nearly black; Pearl, flower a clear soft white; Tom Thumb, scarlet and other colours.

(Tall.)

Spitfire, bright scarlet; Regalianum, flowers a beautiful purple-violet; Lobb's Climbers: These may be obtained of many colours, and are very suitable for vases and hanging baskets.

MOSOTIS.

Universally known and loved for its beautiful little blue, gem-like flowers with golden eye, under the name of "Forget-me-not." It is a perennial plant, but does not thrive well in hot weather. Sown in autumn, it will bloom profusely in spring, covering itself with flowers of the most lovely cerulean-blue.

Being an aquatic, it needs constant watering, and, if grown in a pot, the latter should stand in a pan of water.

VARIETIES.

Palustris, this is the true Forget-me-not, which grows wild in Europe; *Alpestris*, *Stricta Rosea*, flowers pink; *Victoria*, dwarf, globular habit, sky-blue flowers; *Robusta grandiflora*, a very large flowering species; blooms quickly from seed.

HELIOTROPE,

Sometimes called "Cherry Pie," is a well-known plant of unsurpassed fragrance, suitable for pot or garden culture. It is a tender perennial, and should be sown in a frame and potted off, or planted as soon as the young plants are large enough to handle. Sow during autumn and spring. The Heliotrope, like the Fuchsia and many other plants, may be propagated by cuttings, the tender tips of the shoots being used for preference.

VARIETIES.

Queen Margaret, of dwarf and compact habit, flowers in clusters of a deep dark-blue; Madame de Blonay, flowers white; Beauty of the Boudoir and Miss Nightingale, with mixed sorts, are suitable for bedding out.

CAN PLANTS SEE?

Can plants see as well as think? The opinion of the president of the British Association—Mr. Francis Darwin—that plants can remember and can develop habits has been corroborated by Professor Wager, who proved to the scientists that plants not only can see but can see well. He showed that the outer skins of many leaves are in fact lenses, very much like the eyes of many insects, and quite as capable of forming clear images of surrounding objects. This is the case with most leaves, but especially with those that grow in shade. These lenses are so good and focus the light that falls on them so carefully that photographs can be taken by means of them.

The professor has taken a great many, and he showed some of the more remarkable. They included reproductions of photographs of Darwin and Huxley, in which the features were distinct and unmistakable, as well as direct photographs of landscapes and people. Even coloured photographs were exhibited, and like the rest they were remarkably clearly defined. Not only do these plant-eyes see well, but the rays of light which by means of them are focussed on the interior of the leaf are carried to the brain of the plant and affect the subsequent movements.

It has been long known that the leaves of plants move so that they can get the maximum of light. It is now suggested how this movement is made possible, and the process is almost identical with the movements of animals. A close analysis of the eyes in plants proves them, moreover, to be highly developed organs.

TICK PARASITE.

Officials of the Bureau of Entomology of the United States Department of Agriculture have discovered that certain kinds of stock-infesting ticks in Texas are subject to the attack of an internal parasite, and have signified their willingness to assist in getting this beneficial creature established elsewhere. In its adult stage the parasite (*Ixodiphagus texanus*) is a tiny winged insect, somewhat similar in appearance to the parasites which most commonly affect scale insects. It is not known yet whether or not it attacks the very common cattle tick of Texas, which is closely allied to the so-called Blue Tick of South Africa, but it has been bred from kinds in the same genera as the Dog Tick and the Brown Tick. No other true parasite of ticks has anywhere been discovered.

Apiculture.

The hon. secretary of the Queensland Beekeepers' Association forwards the following items:—

Mr. D. Jones, president of the association, reports:—

"I made several inquiries, when at Roma, regarding the quality of prickly pear honey. Mr. Holloway, the veteran beekeeper of the district, expressed his inability to give an authoritative opinion on the matter, as did also Mr. Wells, who has for a number of years kept bees at Pickenjinnie.

"Mr. Wells states that the flowering season for prickly pear is very brief, and he has not a high opinion of the value of the bloom. At Bell, as well as at Pickenjinnie, I found beekeepers well pleased with the prospects ahead this season.

"One bee man said that, quite recently, he took over 120 lb. of honey from one hive. Another averred that, from a bee tree growing near Bell he took over 100 lb., and left an equal quantity ungathered. Asked as to why he did not keep bees, he gave the significant answer: 'Why keep bees when the forest is full of them?'

"This speaks well for the locality as a sphere of operations for the prospective apiarist.

"In the Lockyer district, when looking round the lucerne farms, I was much impressed at the great waste of honey, due to the absence of bees to take advantage of the profusion of bloom seen on every side, as each acre in this in bloom at the present time are ironbark and grey and blue gums which for the most part is wasted; this fact speaks for itself as a profitable field of operation to any who will go in for scientific bee culture."

Mr. G. Butler, Waterworks road, reports that his bees are in the best of condition for either comb or extracted honey. The combs in the brood chamber are simply one mass of brood in various stages of development, some of the combs being completely filled with brood from top to bottom. Honey, too, is coming in very freely, and should we be free from hailstorms, or bush fires, during the next few months, a good yield of honey will be assured. The trees in bloom at the present time are ironbark and grey and blue gums, which show a great profusion of flowers.

FLIES IN THE DAIRY.

The "Journal d'Agriculture Pratique" says, it has been found that flies have a great objection to the colour blue, and if tenements infested with flies are washed with a blue instead of a white wash, flies will desert the place. In support of this, an instance is reported by that journal: "A farmer had 170 cows housed in different sheds; they were pestered with flies, but he observed that in one shed, the walls of which were a blue tint, the cows were not worried. He therefore added a blue colour to the lime with which he washed the walls of his buildings, and from that time the flies have deserted his buildings. The following formula is used by him for the wash:—To 20 gallons of water add 10 lb. of slaked lime and 1 lb. of ultramarine. The washing is done twice during the summer." Any remedy, especially such a simple one, is well worth trying in districts where the flies in summer, in this State, are such a serious pest.

Tropical Industries.

THE FUTURE OF THE RUBBER INDUSTRY.

We have received the following very interesting, if somewhat pessimistic, communication from Mr. Cyril E. S. Baxendale, manager of the Jugra Rubber Estate, Selangor, Federated Malay States. No doubt there is much in what Mr. Baxendale says about the possibility of countries such as Queensland, where high rates of wages rule, not being able to compete with other countries where very cheap labour is obtainable. It stands to reason that the profits of planters who pay from 4d. to 10d. per day must be much greater than those of planters who are, by law, compelled to pay as much as 30s. and 35s. per week for white labour, and, from his point of view, Queensland cannot, under such labour conditions, hope to compete with planters in South America, the Straits Settlements, Ceylon, India, Borneo, Java, or Sumatra. We should be pleased if Queensland or New Guinea planters would give us their views on the subject. Rubber-planting is beginning to obtain a footing in this State, and it would be well if the planters interested would take up this question of labour in connection with not only the rubber industry but other tropical industries at present exploited in cheap-labour countries. Mr. Baxendale writes:—

As an old Queenslander I have read with much interest Mr. Howard Newport's "Notes on Rubber in Tropical Australia." Although I have visited North Queensland, I must confess that I am quite ignorant of the labour conditions now prevailing in that territory; but the success of the experiments will mainly depend on the rate of wages that have to be paid for tapping.

The particulars of growth of *Hevea Braziliensis* (Pará rubber) furnished from the Tully and Johnstone Rivers (65 in. in height and 3 in. in girth for the first year—the plants being 18 in. in height, and as thick as a pencil at planting) compare favourably with those recorded from some tropical countries, but are considerably below the average of plantations in this neighbourhood. At that rate of growth the trees should attain a tappable size in eight years, and then yield from 1 to 2 lb. of dry rubber.

Now, let us consider the probable condition of the trade eight years hence. The world's consumption of rubber last year amounted to about 60,000 tons. For several years past—thanks to the development of the motor industry—the annual increase in consumption has averaged about 5,000 tons. Thus, assuming the present prosperity of the trade is maintained, we may expect a demand for 100,000 tons in 1916. This quantity—I estimate on results that I have myself attained—can be produced from 750,000 acres of cultivation, and when this area is exceeded we must expect very much lower prices to prevail. The probable duration of "fat" years can almost be determined by adding together the areas now under this cultivation in Ceylon, Southern India, the Malay States, Borneo, Java, and Sumatra. Figures are not so easily obtained from certain other countries, where the cultivation is progressing, and said to promise success; but, if the present rate of development is maintained, the countries I have named will have fully 750,000 acres under this product within three years. Thus, it is unreasonable to expect more than three years of good prices when the rubber now being planted comes into bearing—even if we choose to ignore the cultivation proceeding in countries outside those above-mentioned, and the prejudices of an important section of the trade against the plantation product.

I know manufacturers who will not touch our rubber at any price, and many more who are convinced that rubber from young trees lacks the tensile strength necessary for some of the most important branches of the trade.

If any one doubts this, let him watch the prices obtained at London auction sales. Buyers admit that my rubber is at least 20 per cent. purer than the average fine Pará rubber—*i.e.*, the product of the wild trees of the Amazon Valley—and two years ago they paid accordingly. To-day my rubber is even cleaner and of better appearance, but I must be content with a very much smaller premium.

I am hopeful that in course of time these prejudices will be generally removed, but I have little doubt that the wild product of the Amazon Valley will be demanded for special purposes for many years to come, and, if necessary, what we shall then consider high prices will be paid for it; while those who are just now beginning to think about planting will find themselves involved in a struggle from which, all other things being equal, only those who can find the cheapest labour will survive.

The rate of pay in South India, Ceylon, and Malay Archipelago ranges from 4d. to 10d. per diem. Can Queensland compete?

In case it may be argued that, as an old grower, I am solely actuated in writing this by the desire to "keep a good thing to myself," I should like to state that I practise what I preach, inasmuch as I ceased planting rubber on this estate some time ago, and have turned my attention to other products, although the profits at present from the rubber I have in bearing are considerably higher than from any other products I can name.

If I may be permitted to advise, I would suggest that your tropical readers should turn their attention to products which have not been the rage for years past. Soil and climate suitable for rubber are generally equally suitable for fibre cultivation. I burnt my fingers with Ramie (*Rhea* or China Grass), owing to the very limited demand for it; but there are several others, such as *Sansevieria zeylanica* (Bow-string hemp), banana, &c., for which there is a large and expansive market.

COCOA-NUTS.

Cocoa-nut planters in Queensland, New Guinea, the Solomons and other countries and islands in the South Seas, always plant cocoa-nuts near the sea-shore, it having been the established belief that cocoa-nuts grow and thrive best in such localities; but an article was published in the January (1907) issue of the "Journal of the Jamaica Agricultural Society," extracted from the "Bulletin" of the Bureau of Agriculture of the Philippine Islands, which contradicted almost every established belief on cocoa-nut cultivation. We ("Journal of the Jamaica Agricultural Society") then pointed out that there is ever something to learn and ever room for improvement in the methods of growing any crop, so that these ideas were at least worthy of our consideration. The article also pointed out that the application of common salt, especially to light soils, is positively injurious to the cocoa-nut tree. It has been the practice here, where cocoa-nut trees are planted back from the sea to apply salt to the roots of young trees, more especially then is salt put in the hole when the nuts are planted. We all know that cocoa-nuts will grow back from the sea here, and grow well, but the sea breeze sweeps over the whole of our island; in South America and India, however, cocoa-nut trees grow hundreds of miles from the sea, so long as the temperature and soil are suitable. At the same time the cocoa-nut must have originally been a sea-shore loving plant. It is entirely fitted by Nature for such means of transportation, as it floats lightly, and readily sprouts if kept moist, and sends its roots down strongly into the soil it comes in contact with, however sandy and rocky that may be, so long as the rock is loose like coral rock or some of our limestones. Even as doctors disagree, so do expert agriculturists differ apparently, but some of the scientists in connection with the U.S.A. Department of Agriculture, in their energy and zeal are too fond of propounding new theories, and too

ready in recommending the discarding of practices that have stood the test of commercial results. We would rather put faith in the results of investigations where cocoa-nuts have been grown for many centuries, and to such an extent that observations of everything that might affect the trees have been very keen and close, and methods have shown little theory and no sentiment, but every simple practice has been based on what produced the best results under the local conditions.

BOUNTY ON COFFEE.

By the courtesy of Senator T. D. Chataway, we have received a letter addressed to that gentleman by the Assistant Comptroller-General, Department of Trade and Customs, in reply to his request that greater facilities might be afforded to coffee-growers in Queensland in the matter of obtaining the bounty on raw coffee. The following is the letter referred to:—

“Melbourne, 9th October, 1908.

“Senator T. D. Chataway,

“Parliament House, Melbourne.

“DEAR SIR,—Referring to your letter of 26th August last, in which you suggest the desirableness of some arrangement being made by which coffee-planters might, without having to await the results of the hulling process carried out at the factory, receive bounty on the ‘parchment’ coffee sold by them, I am desired by the Minister to state that as the result of inquiries made, it has been decided that when coffee is sold by the grower in the parchment, bounty will be paid on the basis of 100 lb. of parchment coffee yielding 75 lb. of raw coffee.

“Yours faithfully,

“LOCKYER,

“Assistant Comptroller-General.”

[This proportion appears to us to be inequitable, the loss on parchment being about 16 per cent.—Ed. “Q.A.J.”]

SISAL HEMP IN THE BAHAMAS.

From the annual report of the Curator of the Botanical Gardens in the Bahamas (Mr. W. M. Cunningham, formerly of Hope Gardens), we take the following:—

“The export of sisal fibre for the year shows a total value of £40,140. The average selling price of machine and hand cleaned sisal fibre during the financial year was 3½d. per lb. The most important industry is the raising of sisal fibre, used for making binder-twine, ropes, bags, mattings, brushes, &c. Its profits can be judged from the prosperity of the Out Islands. Unaffected by heat, drought, storm, or insects, the sisal crop is certain, and the price is staple. The Bahamas fibre is said to be of superior strength. Its annual yield is variously estimated at from £3 to £10 per acre.

“The estimated area under sisal cultivation is considerably over 25,000 acres. The output exceeds that of previous years, and the acreage is increasing, especially in the Out Islands.

“The enormous trade already existing in sisal, and the increasing demand, with which the production has not yet been able to keep pace, the expansion of the Canadian wheat-growing industry, for which millions of pounds of binder-twine are needed annually, and of late the decrease in the output of Manila fibre, all tend to encourage the planting of sisal.

"Other countries are coming to the front with this sisal fibre industry, which makes it more and more important that no efforts should be spared to bring our product up to the mark in quality. The Hawaiian Islands, Porto Rico, Mexico, and other countries are setting to work with a will to develop a fibre industry; vast quantities of fibre are produced and coming forward for the American market."

A good many years ago a plantation of sisal hemp was established here by Colonel Ward at Moneymusk, but it was given up, owing to the difficulty then of finding effective machinery for dealing with the plant. At the present time, however, there are several machines in the market that are said to be thoroughly effective.

A small plantation has been again set out in Vere, and judging from the confidence in this industry in other parts of the world, we should think it will be very successful. There is talk of another small venture in Trelawny. There are good stretches of land in Jamaica quite suitable for growing sisal. This variety of agave, as well as others, and also *Sansevieria*, grow wild in the driest parts, and are common. The most suitable soils are light, dry, well-drained, on a limestone foundation, and these are common here, and once the plant is established, no dry weather can kill it out.

This cultivation has made Yucatan, the poorest endowed part of Mexico by Nature, perhaps the richest in actual wealth. The export of fibre from Yucatan is about 600,000 bales, of a value of £3,500,000. The importations into the United States in 1905 amounted to 8,265,819 lb., at an average of £35 per ton. The price per ton, which was £15 0s. 3d. in 1894, has steadily increased every year until now it ranges from £35 to £37 10s. per ton. On dry lands plantations of sisal hemp could be easily and cheaply established, and crops of cotton taken off between the rows when the sisal plants were small.—"Journal of the Jamaica Agricultural Society."

A NEW CANE-CUTTING MACHINE.

For several years inventors have been at work with the object of producing a machine which will not only cut, but also top, the sugar-cane. None have hitherto been successful. Whatever machine has been, or may be, invented for the purpose, it is certain that none will ever work satisfactorily on rough stony land, where, in many cases, the finest cane is grown. Once more an inventor has entered the field, and everyone, whether cane-grower, mill-owner, or general farmer, will heartily wish him success. Mr. W. J. Howcroft, of South Brisbane, is the inventor of a machine which, he claims, will prove that he has overcome all the difficulties which previous inventors have been unable to cope with. As soon as the necessary motors arrive from America, a public demonstration will be given, probably at Bundaberg. The invention, which at present is financed by a local syndicate, has been patented in all sugar-growing countries, as well as in Great Britain. Mr. Howcroft supplies the following information concerning his invention:—

Like an ordinary harvester, the machine runs outside the cane, and the motor power sets in action a series of blades, which are aptly termed "feelers" or "fingers," which, when not in use, can be raised to a height of 18 in. above the ground. When working, these "fingers" are lowered, and seize the cane in the same manner as would be done by a man when cutting. Beneath them are cutting knives, rotating on a lever at high speed—some 400 revolutions per minute. These are so arranged that they can cut the cane an inch or more below the surface of the ground, a most important point, as all sugar-growers know. As soon as the canes are cut, they pass on a movable platform to a man who watches till the canes reach the point at which they would be topped by the human cane-cutter. Then the topping knives, which revolve at the same

speed as the cutters, top each cane at the right point, after which they are delivered on the ground by means of a trough. The tops themselves are passed out separately. The machine is worked by means of two small oil motors.

Should this machine fulfil its inventor's expectations, the cost of cane-cutting will be so reduced—amounting, it is claimed, to a saving of five-sixths of the present cost—that cane-growers will reap an enormous benefit. The machine is expected to cut 150 tons of cane a day, which would mean that a 30-ton crop on 50 acres would be harvested in 10 days. This rapid work, if it be accomplished, will be of incalculable benefit to growers and mill-owners where cane has been heavily frosted, as occurred this year. Thousands of tons of cane could have been saved which became either a partial or total loss, owing to the impossibility of getting the frosted cane off in time, seeing that, at the most, smart cane-cutters can only cut about 3 tons a day, even when working—as many cutters do—as long as 10 and 12 hours a day. In 1907, 94,384 acres of cane were crushed out of a total area planted of 126,810 acres. The weight of cane crushed was 1,665,028 tons. Should this machine fulfil the expectations of the inventor, its value to the sugar industry cannot be over-estimated.

WAX AS A BY-PRODUCT OF SUGAR-CANE.

The "Daily Argosy" (Georgetown), British Guiana, of the 13th June, states that a patent has been applied for with respect to a process for the extraction of wax from the sugar-cane. It seems that the rind of the cane contains a certain proportion of wax, which has hitherto been lost with the refuse. By the new process this wax is now recovered from the filter refuse and turned to commercial uses. It is estimated that 1 ton of cane will yield 0.4 kilo of wax, very similar in its characteristics to bees'-wax or Carnauba wax, and suited to the same purposes for which those waxes are utilised. The wax in question, which resembles that now used very largely for making cylinders for so-called talking machines, is exceedingly hard, and capable of taking a high polish. It is understood that 110 factories in Java will be using this process during the present year.—"Board of Trade Journal," 9th July.

LABOUR AND IRRIGATION ON HAWAIIAN SUGAR-CANE ESTATES.

Reports from the Hawaiian Islands all testify to the fact that the cane crop season of 1907-8 has been a very prosperous one. The crop yields actually obtained have exceeded the estimates, and prices have continued satisfactory through the season. The most recent estimates place the entire sugar crop of the islands at about 500,000 tons, as compared with 390,000 tons in 1906-7.

The Hawaiian correspondent of the "American Sugar Industry and Beet Sugar Gazette" states that the question of the best method of dealing with labourers on the sugar plantations is receiving a good deal of attention in Hawaii. The actual rate of remuneration which the labourers are to receive does not form the question under debate, but it is the manner in which this wage or remuneration shall be paid, so as to be most satisfactory to the labourers themselves, and also result in the most effective cultivation and best returns to plantations, which is under experimental consideration.

As far as the white labourers are concerned, a good deal has been done to make it possible for them to secure homesteads of their own, with a small amount of tillage land attached, so that they will be able to add to their income, or provide part of the provisions required for their family from their own gardens, while working on the plantations for money wages. On one large plantation about seventy families have each been enabled to secure about

5 acres of land from the Government, and these small areas are utilised for the cultivation of pineapples. A pineapple cannery has been built, and the pineapples raised by these small cultivators are purchased at a given rate.

Other plantations have started an arrangement under which a certain specified area of land is given to a group of labourers to be cultivated with sugar-cane, the plantations buying the cane at maturity on a sliding scale of prices varying with the price of sugar. The figure paid for the labourers' canes varies from 2'50 dollars when the price of sugar on the New York market is 3 cents per lb. to 3'50 dollars per ton when sugar in New York is selling at 4 cents per lb.

Irrigation is carried out on a considerable scale on the sugar-cane lands of the Hawaiian Islands, more especially in Maui. In this latter island, various irrigation works which were previously under the direction of different authorities have recently been brought under the control of one corporation. This arrangement should result in less wastage and more efficiency, and should assist towards the further development of the sugar-cane industry of the island.—“Agricultural News,” Barbados.

BRITISH DEMAND FOR QUEENSLAND SISAL FIBRE.

The efforts of those who have so determinedly advocated and put to practical proof the cultivation of the sisal plant in Queensland, combined with the information supplied by the Queensland officials at the Franco-British Exhibition in London, have been successful in drawing the attention of merchants and proprietors of ropeworks, not only in the Commonwealth but also in the United Kingdom, to the possibility of obtaining supplies of fibre from this State. Inquiries as to the prospects of a trade in the article have reached us from Belfast, Aberdeen, and Mannheim-Neckerau, in Germany. The Department of Agriculture and Stock has received an inquiry from Messrs. Mercier and Sinfield, manufacturers' agents, of Luton, Bedfordshire. They write:—

“Your Director, Mr. J. Campbell, has given us your address for our inquiry *re* hemp.

“We are buyers of sisal hemp and all other types of hemp. We have noticed several samples in your exhibits, and would esteem it a great favour to have your samples and prices free London at your earliest convenience. Please state terms, and if you would be able to obtain agency for us. We represent large manufacturers, and have as clients all the leading makers, to whom we could dispose of these goods. . . .”

ESTIMATING WEIGHT OF HAY.

In estimating the weight of hay in a stack by measurement, everything depends on the solidity of the stack. Hay runs from 220 to 320 cubic feet to the ton; the more solid the stack, the fewer the cubic feet required to weigh a ton. Average stuff would run about 270, but judgment is required as to what figure to take. To find the cubic contents of a square-cornered stack, measure the length and breadth about half-way between the bottom and the eaves, allowing about 6 in. for loose hay on the outsides. Then take the height from the bottom to one-third of the distance between the eaves and the ridge, and multiply the length by the breadth, and that total by the height. If all the measurements are in feet, the result will be cubic feet, and that total divided by whichever of the figures given above you select will give the number of tons approximately.

Animal Pathology.

TICK FEVER, OR REDWATER.

By SYDNEY DODD, F.R.C.V.S., Principal Veterinary Surgeon and Bacteriologist.

APPEARANCES AFTER DEATH.

It is necessary to make the examination of an animal as soon after death as possible, as in this country decomposition sets in very rapidly. The appearances of the carcase vary according as to whether the disease is acute or chronic. In the acute cases, where the disease has lasted only a few days, the lungs are swollen and watery; the heart-bag may contain a little blood-coloured fluid, whilst the heart itself may show numerous blood spots or patches. Blood spots may also be seen on the lining of the stomachs. The bowels are inflamed, sometimes so deeply in places as to be almost black; at other times it is slight. The liver is greatly enlarged, and is of a dark-brown colour. The gall bladder is distended with dark, thick, green bile, and its covering has often blood spots on its inner surface. The spleen or melt is always enlarged. It may weigh up to 8 or 10 lb., and when cut into, the pulp appears as a thick, dark mass, like jam. The kidneys are dark and congested. The bladder is usually swollen, and contains dark-coloured urine.

Cases which have lasted some time, usually have a different appearance. The carcase is emaciated, and, on skinning, it has a jaundiced appearance. The muscles are watery and flabby. The spleen is enlarged; the liver yellowish-brown; the bile has flakes of semi-solid material in it; the bladder and the urine may be normal; the kidneys pale and watery; blood spots are usually present on the inner and outer surface of the heart.

It may be as well to mention two diseases that may be mistaken for Tick Fever, especially as stock-owners are, at the present time, very prone to attribute any fatal case of disease among their cattle to Tick Fever, and these are Blackleg and Anthrax.

In Black-leg, however, the disease usually only attacks cattle between the ages of six months and two years. The spleen and liver are unaffected, and there is usually, on some part of the body, a tumour-like swelling, which crackles when the hand is passed over it. If cut into, this has a peculiar smell, something like rancid butter.

With Anthrax, the animal is often found dead with no previous symptoms of illness. There is generally a blood-stained liquid exuding from the natural openings. If the carcase is opened (which should never be done if Anthrax is suspected), the veins under the skin are seen to be distended with blood, and in these and throughout the body, the blood is dark and tarry in appearance. The latter, as a rule, does not clot well. The spleen is almost always greatly enlarged, but the pulp is more liquid than in Redwater. There is intense inflammation of the bowels and fourth stomach, and there is often a good deal of liquid blood in them.

TREATMENT.

Unfortunately, there is little to be said at present as to the curative treatment of Tick Fever. Numberless remedies have been exploited and tried by many persons, but none have as yet stood the test of actual experience over a large number of cases. In many instances, drugs have been credited with doing what Nature would have performed herself unaided by them. There are instances, however, in which the judicious administration of medicine will enable the animal to combat the disease. If the animal is constipated, a drench of 1 lb. of Epsom salts in a quart of warm water or 60 grains of calomel in a little gruel may be given, care being taken in drenching, and the animal handled gently. It is necessary to state that on no account should an

animal be drenched through the nose, as it would probably kill the beast if it happened to go the wrong way. The continual administration of strong purgatives, however, is not to be advised, once the bowels are acting. If the animal appears depressed, one may give $\frac{1}{2}$ -oz. of aromatic spirits of ammonia, or $\frac{1}{4}$ -oz. of carbonate of ammonia, with 1 dram of quinine, in about a quart of water, twice or three times a day. Mix the ammonia with the water first, and then add the quinine. It must be confessed, however, that quinine, although very valuable in cases of human malaria, has very little effect on the Tick Fever organisms.

There is a practice obtaining in certain parts of Queensland of bleeding an animal when suffering from Tick Fever. This I consider to be totally wrong in the light of what we know is going on, for this disease is characterised by more or less destruction of blood cells, and it should be one's endeavour to build the blood up, not to further weaken the animal by abstracting more blood. Good nursing is the great thing with animals suffering from Tick Fever. The animal must be given plenty of good water and fresh green food if it will eat, and also kept quiet and in a shady place. The latter they will generally find themselves if it is obtainable.

As regards what is to be done when Tick Fever breaks out on a farm, the best thing is to dip or spray all the animals that are not too sick, and remove them to clean paddocks. Those which are too sick to be dipped should have all the ticks picked off by hand where practicable, and then put in a place where fresh ticks cannot get on them until they have recovered. A grass-free yard is most suitable. Hand-picking is very laborious, but where only a few cattle are affected, it repays the trouble taken.

When no more cases of illness occur, inoculation can be performed with a minimum amount of risk. The recovered cattle will not need inoculating, as they will have become naturally immune.

PREVENTIVE TREATMENT.

This may be divided into two sections—(1) the prevention of animals becoming infected; (2) the artificial setting up of a mild attack in a beast in order that it may be protected from the more severe, and often fatal, natural infection. With the first heading it may naturally be asked, "How are we to prevent an animal contracting Tick Fever now that the whole coastal country is more or less infested with ticks?" The answer to that is, "Get rid of the cattle tick and you will get rid of Tick Fever." Now, at first sight this seems a very hopeless kind of problem to be set, for it looks like destroying countless millions of ticks over hundreds of miles of land; but, if it is reasoned out a little, it will be seen that it is not such a foolish idea as it looks. We know the life history of the cattle tick, and that it must spend some part of its life on an animal, which is usually an ox or a horse. If this host is not present, the tick must eventually die; therefore, if horses and cattle are kept off a tick-infested paddock, that paddock in course of time—say, twelve months—will become naturally tick free. Then there is the subject of dipping. If ticks are destroyed on an animal, it follows that no eggs can be laid by them, and, consequently, no fresh ticks are hatched out. Not only is regular dipping to be advocated for the purpose of reducing the number of ticks, and so lessening the chances of an animal becoming infected, but also for preventing tick worry, which is a common thing in some parts. There is no need to enlarge upon the loss stock-owners suffer when their cattle are grossly infested with ticks. Animals lose condition, and in dairy herds the loss in milk production is serious. Tanners also inform me that the value of hides is greatly depreciated by ticks. The loss in milk is not to be wondered at when one compares the difference in size between a young larval tick and a fully engorged female, and when one multiplies this by the many hundreds one often finds on an animal it does not require much calculation as to the quantity of blood these pests abstract from a cow, and it must be remembered that this represents highly concentrated food elements that have been elaborated by the animal on which the tick is

feeding, so that the farmer is not only feeding the cow but the tick also. Therefore, regular dipping is to be recommended in all cases; but, as well as dipping, fencing must be insisted on also, for there is a difficulty to be met with. It is no new thing to be informed by farmers that they have been anxious to rid their cattle of ticks, and, therefore, have dipped them regularly until, in some cases, no ticks remained, but the adjoining paddocks belonging to neighbours have been swarming with infected ticks. Somehow, either by a broken fence or some other means, their cattle have got on to the infested ground, or infested cattle have got into their paddock, or, in travelling their stock to other districts, the cattle pick up infected ticks, and the result has been a heavy loss from Tick Fever, owing to their own cattle having lost their immunity. However, this should not discourage an owner from eradicating all the ticks from his land, as he may avoid such loss by inoculating his cattle regularly about every 18 or 24 months, as well as by dipping. In this way he will not only have his cattle tick-free, but also immune from Tick Fever, should infected ticks get on to his land, and, of course, he should see that all new cattle are dipped before being brought on to the paddocks.

The question of tick eradication has only been lightly dwelt on, because the problem is an enormous one, involving considerable expenditure, and public opinion is not yet ripe for such a proceeding. There are many obstacles in the way, too, such as the absence of fences in many places and the presence of scrub cattle. It is well known that on many runs the owner often does not see some of his cattle from one year to another, and there would be great difficulty in dealing with these. Then there is the fact that larval cattle ticks are often spread about mechanically by wild animals—*e.g.*, kangaroos, wallabies, &c.—other than their natural hosts. There is another aspect of the question which is quite familiar to many, and that is, the straying of tick-infested cattle or horses on public roads and lands, and one cannot refrain from remarking that some local authorities in Queensland have not exerted the powers conferred upon them for controlling this undoubted means of spreading ticks. Now, under the Local Authorities Act (section 157), the Minister has the power, at the request of the local authority, to proclaim the tick a pest, and then the local authority can pass by-laws for the eradication of it. As a matter of fact, some local authorities have passed the necessary by-laws, but have taken no steps to enforce them, thus rendering the whole thing a dead letter. Bullock-teams are also very active agents in spreading infected ticks from place to place.

PREVENTIVE INOCULATION.

Preventive inoculation is practised under the following circumstances:—(1) When fresh stock from an uninfected district are to be introduced into an infested area; (2) when the disease has newly appeared in a district, and it is desired to render all the susceptible cattle immune with the least possible loss.

The term is not strictly correct, because, instead of preventing Tick Fever, one really gives the animal a mild attack of the disease. It is well known that one attack of Tick Fever confers on an animal a great, but not absolute, protection against another attack, and, as previously stated, this knowledge was acted upon by taking blood from an animal that had recovered from the disease and injecting it under the skin of a susceptible animal by means of a syringe. The result was to set up an attack of Tick Fever, but not in so fatal a form as that induced by natural infection; the usual loss from natural tick infection often being from 50 to 90 per cent., whereas that from artificial infection is often under 2 per cent., but sometimes it is a little higher.

A short account is here given of the inoculation carried out under the supervision of the Veterinary Division.

Inoculation of stock for Tick Fever in Queensland was recommenced in September, 1907, it having dropped out of general use since 1900, although a few cattle were occasionally done, chiefly imported stock. No statistics that are of any value are available regarding inoculation carried out at that period.

During the nine months ending July, 1908, a total number of 34,160 head of cattle have been inoculated by the Department. Up to the time of writing, reports have been received on 30,114. Of these, 19,831 were highly susceptible to Tick Fever—that is to say, Tick Fever was present in the district, but had not appeared in any herd to which these cattle belonged; 393 of this number died subsequent to inoculation, giving an average of 1.98 per cent. The remaining 10,283 were partially susceptible—that is, probably some had become immune from natural infection. Of these, 60 died, being an average of 0.58 per cent. So that the average total loss from inoculation among the animals reported on has not been more than about 1.5 per cent.

There are instances, however, where the loss in an individual herd has been greater than this, but on investigation it has usually been found that there have been other factors at work besides the artificial inoculation. For instance, in one locality, out of 221 head inoculated from an untested "bleeder" (this is the common name amongst Queensland stock-owners for an immune animal whose blood is used for inoculation purposes), 20 died; and of 495 inoculated from a tested "bleeder," 26 died; but in this case Tick Fever was rife in the district, and there is no doubt that a number of these animals were infected by ticks at the time of inoculation, or before they were protected by the latter process. In another district 20 animals were lost out of 158 head inoculated, but here again the animals were dying of Tick Fever at the time of inoculation. In a third case, there were 9 deaths out of 20 head inoculated, but these cattle were inoculated at a certain town and trucked immediately, against advice, to a Redwater district, and here again these animals probably became tick-infested before they were protected by inoculation, besides having their vitality lowered at a critical period by being travelled. These instances are given because there are often wild rumours set about that the Department has inoculated cattle and the owner has, as a result, lost nearly all his herd. On these rumours being investigated, they are found to be without any foundation at all; or, where the loss has been rather heavier than usual, it is because the herd was already infected with Tick Fever, and inoculation cannot cure the disease; or the inoculation has been performed by a private inoculator with an untested "bleeder."

Of course the number of animals here given does not by any means represent the total number inoculated in the country. With herds numbering from 1,000 upwards, the Department encourages the owners to perform the operation themselves. The figures here given are intended to show that the loss is not great if the inoculation is conducted properly.

As to the best time of the year in which to inoculate, Spring or early Summer is no doubt the best, as the ticks are less numerous, there is plenty of green feed, and the weather is not too hot. Winter in the Northern parts would not be unsuitable, but, unfortunately, at that time of the year, feed is scarce, and cattle might suffer more severely owing to their being in low condition. Mid or late Summer is not a favourable period for inoculation, owing to the heat.

As a result of inoculation, no doubt in dairy herds there is a temporary diminution of the milk supply, but the statement that it also causes all in-calf cows to abort, is apparently not strictly correct. From reports received from dairy herd-keepers there is no doubt a risk of a cow slipping her calf if pregnancy is very far advanced, but, unless this is the case, it does not appear to have a great effect in preventing a cow carrying her calf to full time.

The various sources from which one may obtain blood for inoculation purposes are:—

1. From an animal that has recovered from a natural attack of Tick Fever.
2. From an animal that has been artificially inoculated.
3. From an animal that has been born and reared in a Tick Fever district.

The best method is to obtain blood from an animal that has been inoculated with blood from a known case of Tick Fever and has shown a decided fever reaction.

PREPARATION OF THE ANIMAL TO BE USED FOR BLEEDING PURPOSES.

One or more healthy yearling calves, depending upon the number of stock to be inoculated, should be chosen, if possible, from an uninfected district, and 10 cubic centimetres of blood, obtained from an animal recently recovered from Tick Fever, injected under the skin behind the shoulder by means of a 10 cubic centimetre hypodermic syringe. The calves should then, where practicable, be placed in a sheltered yard or bails, with plenty of green food and water, whilst undergoing the reaction. It is well not to let them run loose in a paddock, as the excitement caused by catching them when required for taking temperatures will often cause their temperatures to go up.

The temperature of each animal should be taken night and morning, commencing on the 6th day until the 26th day. During summer the morning temperature should always be taken as soon as possible after dawn, and the evening one at or after sunset. In the summer, during the heat of the day it is a common occurrence for the temperature of healthy young cattle to vary several degrees.

The temperatures should be entered in a book and kept for reference.. Only those animals whose temperatures reach 105 degrees Fahr. or over, should be used for bleeding purposes. From 6 to 10 weeks should be allowed to elapse before any immune animal is used for inoculating.

An animal whose blood is to be used for inoculation purposes should not be bled unless it is in good health. It is well to take the temperature before bleeding, and, if above normal—101·5 degrees Fahr.—the animal should not be used until the fever has subsided. The animal should not be bled at shorter intervals than a fortnight, as too frequent abstraction of blood lowers the animal's vitality, thus enabling the organisms in the blood to multiply. Blood from an animal in such a condition is liable to cause a more severe reaction than it would under normal circumstances.

For the same reason, an animal should not be bled immediately after a long journey, but should be allowed one or two days' rest first.

It should be understood that individual animals vary a great deal in the intensity of the reaction which their blood induces when injected into susceptible animals, the blood from some animals giving a very mild reaction, whilst, on the other hand, others cause such a large mortality as to be unsafe to use for the first inoculation of highly susceptible cattle. It is, therefore, necessary before the blood of any immune animal be used, that it be tested on a few very susceptible animals, aged ones for preference. If the blood be found too virulent, a milder one must be used.

The immune animal giving a mild reaction is the most valuable for bleeding purposes. Its blood, as a rule, causes scarcely any recognisable reaction amongst young stock, except a rise in temperature shown by the clinical thermometer; but it usually causes aged susceptible animals to become visibly ill, though it is rarely fatal. Such blood is invaluable for the inoculation of highly susceptible or aged cattle. In cases where the protection afforded by the mild reaction is not considered sufficient, a much more virulent blood may then be used (allowing the usual time to elapse) with a greater degree of safety.

Another thing to be borne in mind is that the severity of the reaction shown in a "bleeder" is no indication of the reaction its blood will produce in other animals—*e.g.*, a "bleeder" may nearly die through its inoculation, and yet its blood produce a very mild reaction in very susceptible animals. On the other hand, the blood of a "bleeder" which has scarcely reacted may be too virulent to use as a first inoculation.

METHOD OF BLEEDING AN IMMUNE ANIMAL FOR INOCULATION PURPOSES.

When only a small quantity of blood is required, the animal may be tied by the head to a post, a piece of cord or strap placed round the lower part of the neck, as near the chest as possible, and pulled tight in order to make the jugular vein stand out prominently. Then the hair is clipped from over the vein, and the part washed with a solution of a disinfectant, such as cyllin, 1 part in 100 of water, or lysol, 2 parts in 100 of water. The needle of a 10 c.c. hypodermic syringe is then inserted into the vein, and a syringe of blood sucked up. If the blood is injected at once without delay into an animal, it will not have sufficient time to clot, but, if a number of animals are to be inoculated, then measures must be taken to prevent the blood clotting before it is used.

The animal to be bled is thrown on the side most convenient to the operator, and secured by a rope. The head is stretched out; sometimes a block of wood or stone is placed under the neck; the jugular vein is distended by a cord, the hair clipped, and the skin washed as above described. A trocar and canula is then pushed steadily, straight into the skin over the vein about 2 inches in front of the cord, and an endeavour made to pierce the vein. If the skin is very thick, this may be first carefully cut with a sharp knife. As soon as the vein is pierced, the trocar and canula is turned in a slanting direction, so that it points towards the animal's head. The trocar is then withdrawn, leaving the tube or canula in the vein. If the canula has been inserted in the right place, blood will immediately spurt out; if not, the trocar must be replaced, both the trocar and canula withdrawn a little, but not out of the wound, and another endeavour made to find the vein.

When the vein is punctured, the blood is allowed to flow into a clean jug or jar; then, in order to prevent it clotting, it is whipped or stirred vigorously for a few minutes with a few clean wing feathers or twigs (these having been previously placed in a solution of disinfectant for half an hour, and then thoroughly washed in clean boiled water until all trace of disinfectant has been removed). The blood is then strained through a piece of clean muslin into another jug. Another, and more simple way, is to place a little citrate of potash dissolved in water in the vessel in which the blood is being caught. This will prevent the blood clotting without the necessity of stirring it. A teaspoonful of citrate of potash dissolved in about two tablespoonfuls of cold water (previously boiled) will keep a pint of blood fluid. It does not interfere with the reaction of the blood. From a yearling in good condition, from a pint to a pint and a-half of blood may be withdrawn without any risk; from a two-year-old beast, two to three pints; and from three years old and upwards, two to three quarts.

It appears from practical experience, that animals which have been continually used for a period of years for bleeding purposes have gradually ceased to give a satisfactory reaction—that is, the reaction is so mild that it is not sufficient to protect an animal from natural infection. In these cases it is better to prepare a fresh animal rather than endeavour to fortify the blood of the beast which has lost its potency. It should also be remembered that immune animals will lose their immunity in a year or two, and so be useless for inoculation purposes if they are protected from natural tick infection.

INOCULATION OF CATTLE.

Cattle which are used to being handled, such as dairy cattle, may be secured for inoculation by putting a rope over their horns and tying them to a post, or by placing them in a bail. Other cattle will need to be put through a crush. When inoculating, it is convenient to have a small clean bottle to hold a small quantity of blood by which the syringe can be refilled. This bottle can be replenished from the larger vessel from time to time, the latter being covered with a cloth to protect it from flies, dust, &c. The small bottle can be held by an assistant. The operator having filled his syringe with blood approaches the animal, and takes up a loose fold of skin behind

the shoulder between the fingers and thumb of one hand, whilst with the other hand he rapidly inserts the needle in a slanting direction under the skin. The nozzle of the syringe is then inserted into the neck of the needle, the necessary amount of blood injected, and the needle withdrawn—a little rubbing on the spot is useful in order to disperse the blood.

The dose varies from 1 c.c. to 3 c.c.s., according to the virulence of the blood and the age of the animal to be inoculated. As a general rule, however, with blood of moderate virulence the dose usually injected is 3 c.c.s.

For inoculating moderate numbers of cattle, a 10 cubic centimetre hypodermic syringe, graduated in cubic centimetres, is most suitable. It should be such as will permit of its being boiled when the inoculation is finished. Asbestos plungers are better than rubber ones, as the latter soon perish.

When very large numbers of cattle are to be inoculated, a special form of syringe devised by Mr. C. J. Pound has been adopted. The syringe is so arranged by means of tubes and valves that, by simply pulling out the piston of the syringe and pushing it in again, the correct amount of blood is sucked up from a bottle and injected through the needle into the animal, thus obviating the necessity of continually filling the syringe and measuring out the dose.

The method of cleaning this latter apparatus is as follows:—As soon as the inoculation is finished, a quantity of a solution of disinfectant should be pumped through the tubing, &c., until the fluid is no longer bloodstained. The tubing should then be removed, and kept in a vessel covered with a 2 per cent. solution in water of cyllin or lysol. The portions A and B of the double valve, the needle, handle, and syringe may be boiled.

All instruments, &c., except the thermometer, should be well boiled for a few minutes before and after use, and the utmost cleanliness should be observed during the operation. When boiling is impracticable, billy cans, bottles, muslin, &c., used for containing blood should be washed with boiling water before use.

Immediately after inoculation, cattle should, if possible, be placed in a paddock where there is plenty of food, shelter, and water, and should be disturbed as little as possible. Cattle should not be travelled for at least six weeks after inoculation. Any undue exertion while undergoing reaction will often result in heavy loss. A few quiet animals should be picked out of the herd and kept in a small paddock near the crush, for the purpose of taking temperatures, and so checking the reaction.

To ensure a satisfactory result, the blood should be used as soon after it is drawn as possible. Firstly, because the blood loses its virulency after being kept any length of time unless specially prepared; and, secondly, because the blood soon becomes contaminated with bacteria after being drawn, and, if kept long, the result of its use would probably be the formation of an abscess at the seat of inoculation.

If the inoculation has "taken," the result will be a rise of temperature on about the 10th day. It may occur as early as the 6th day, often not until the 14th day. It must be noted that an animal need not necessarily be on the point of death before one decides that it has reacted. Sometimes the reaction is so mild that the animal scarcely shows any visible signs of illness, and, if the owner neglects to take temperatures, he will often conclude that his cattle have not reacted. With mild reactions the temperatures seldom rise above 104 degrees or 105 degrees Fahr. With more severe reactions the temperature reaches from 105 degrees to 107·5 degrees Fahr., and the animal is visibly ill. The high fever may last from 4 to 7 days. In the very severe and fatal cases death generally occurs between 13 and 17 days after inoculation. The remarks as to treatment of cattle naturally infected apply here also. Inoculated cattle must not be kept amongst uninoculated ones if the paddocks are tick infested.

When taking cattle from clean to infected country it is advisable to inoculate them before leaving the clean district. If inoculation is delayed until they reach the infected area, there is great risk of the cattle picking up

infected ticks before immunity is established, and the loss may be severe. If susceptible cattle must be taken into infected country before they are rendered immune, they should be protected from infected tick infestation, as

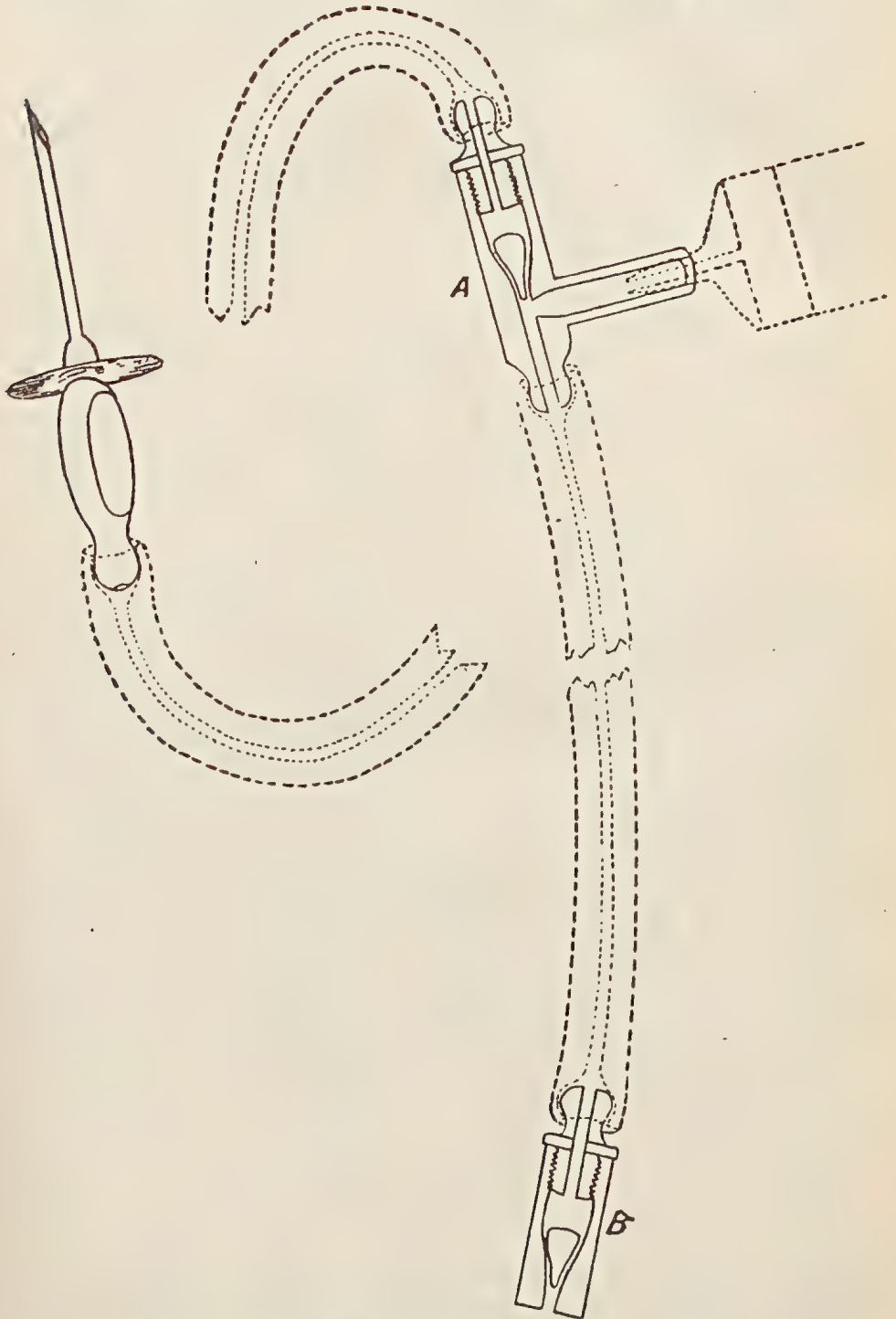

Sketch showing improved inoculating syringe and position of valves when in use. Reproduced from *Queensland Agricultural Journal*, January, 1908.

far as possible, by being placed in a horse paddock, or in a stable, or a yard where there is no grass, until the reaction from inoculation is over.

All animals do not invariably react at the first inoculation, and those failing to do so should be done a second time. It is, of course, common knowledge that a certain percentage of animals do not give any reaction even when inoculated several times and with very virulent blood. The probable explanation of this is, that the majority of these non-reacting animals have already at some period gone through an attack of Tick Fever, and so become immune. It must also be clearly understood that it is not advisable to inoculate cattle when they have just become naturally infected by ticks and are showing signs of disease, because, as it will be readily perceived, this will only be adding fuel to the fire while they are ill, as besides the natural infection, one would be artificially infecting them at the same time, thus giving the cattle a double dose. In those cases where Tick Fever has broken out on a farm, the measures previously recommended should be adopted, and, when the outbreak has subsided, the remaining cattle which have escaped infection can be protected by inoculation. In several instances where cattle have been inoculated and the resultant losses heavy, on investigation it has been found that the herd was suffering from natural Tick Fever at the time inoculation was performed.

It must also be pointed out that if cattle are subjected to infection by ticks, as is often the case, before the animal is protected by the artificial inoculation, which is usually not earlier than about six weeks from the date of inoculation, the risk of a fatal termination is greatly increased, as it also is if the animals are travelled before the reaction is over.

Then there is the question as to how long immunity lasts in an animal recovered from Tick Fever? The general view now is that immunity does not last so long as used to be thought—that is, of course, provided the animal is not reinfected. If an animal recover from a natural or artificially induced attack of Tick Fever, then all ticks are removed from it, and the beast taken to a clean country where there are no ticks for about two years, or in some cases even only twelve months, and if that animal were taken back into tick country, it would probably contract Tick Fever as readily as any other susceptible animal. There have been cases where a cow has remained immune for ten to thirteen years without being reinfected, but these are exceptions. In a tick country, once the animal recovers, the immunity is kept up by constant tick infection, and therefore, as previously advised, if a man keep his stock tick free in a tick-infested country, he can still protect his cattle by inoculating them every eighteen months or two years. The risk of loss then only lies with those animals which have lost their immunity, and with the young stock there is practically no risk if they are in good health and are inoculated under the age of nine months. It has been proved by practical experience that animals recovered from either natural or artificial infection gain a great amount of protection against subsequent attacks, but, unfortunately, this protection is not proof against everything, and it can be broken down. Animals that have once suffered from Tick Fever may have a second attack, or even a third one, providing their vitality is lowered in any way. This may be brought about by various means, such as travelling stock too long distances without rest, overwork, galloping them about a paddock, over-heating before, and rough handling during dipping, starvation, want of water, or an attack of any other disease, or even if they become heavily infested by the progeny of ticks dropped from another and acute case of Tick Fever. This will explain the many mysterious attacks of Tick Fever which are reported. It should also be remembered that the power of the same organism varies a great deal in different parts, and the immunity which may be quite sufficient in one district may not be strong enough to protect in another. It is a well-known fact both in Queensland and South Africa, that cattle which are immune in one district, have contracted Tick Fever again when removed to

another. This will indicate the advisability of a stock-owner dipping any new cattle before bringing them on to his land, as ticks from another district may introduce a more virulent type of the disease.

Finally, there is the problem as to whether cattle should be inoculated in a district where ticks exist, but no Tick Fever. There is no doubt that inoculation in this case introduces the disease and also keeps it alive, and I do not advocate inoculation in these localities unless the disease has appeared in the neighbourhood; but under the present circumstances, owing to the movement of cattle, it is only a matter of time before an animal which has recovered from Tick Fever is introduced into the district, as it is not practicable to test every animal before bringing it on to a farm, and then this animal will infect the ticks on the place, and so start a fresh centre of infection.

Statistics.

COMMONWEALTH METEOROLOGY.

RAINFALL OF QUEENSLAND.

TABLE SHOWING THE TOTAL RAINFALL FOR EACH MONTH OF THE YEAR IN THE AGRICULTURAL DISTRICTS OF QUEENSLAND.

| STATIONS. | 1907. | | | 1908. | | | | | | | | | |
|--------------------------|-------|------|-------|-------|-------|-------|--------|-------|-------|-------|------|-------|------|
| | Oct. | Nov. | Dec. | Jan. | Feb. | Mar. | April. | May. | June. | July. | Aug. | Sept. | Oct. |
| <i>North.</i> | | | | | | | | | | | | | |
| Bowen | 0.06 | 3.71 | 6.39 | 10.14 | 5.63 | 9.46 | 3.73 | 0.99 | 0.45 | 0.88 | 0.51 | 0.96 | 2.47 |
| Cairns | 0.68 | 5.35 | 28.33 | 27.02 | 8.03 | 20.60 | 5.99 | 3.05 | 0.59 | 3.70 | 2.12 | 0.74 | 3.07 |
| Geraldton | 1.42 | 6.45 | 33.82 | 44.39 | 13.27 | 39.00 | 14.23 | 18.52 | 2.64 | 8.11 | 3.66 | 2.81 | 6.93 |
| Gindie State Farm | 0.61 | 1.57 | 4.42 | 0.20 | 7.17 | 6.25 | 0.02 | 0.112 | ... | 0.40 | 1.27 | ... | ... |
| Herberton | 0.17 | 3.41 | 9.57 | 9.29 | 5.02 | 8.92 | 1.40 | 0.38 | 0.31 | 2.36 | Nil | 0.51 | 1.27 |
| Hughenden | 1.66 | 0.66 | 7.75 | 0.98 | 5.18 | 8.91 | 0.30 | Nil | 0.05 | 0.68 | Nil | Nil | 1.67 |
| Kamerunga State Nurs. | 0.53 | 2.76 | 29.32 | ... | 7.47 | 25.75 | 4.60 | 3.363 | 0.76 | 4.85 | 1.53 | ... | 3.64 |
| Mackay | 0.12 | 5.76 | 9.70 | 9.28 | 3.83 | 17.43 | 14.82 | 3.25 | 1.29 | 1.65 | 0.71 | 2.27 | 1.80 |
| Rockhampton | 0.47 | 3.72 | 4.42 | 3.84 | 9.64 | 9.77 | 2.62 | 0.85 | 0.10 | 1.08 | 0.84 | 0.20 | 2.14 |
| Townsville | 0.03 | 2.82 | 24.26 | 12.21 | 6.69 | 9.03 | 0.38 | 2.22 | Nil | 1.70 | 0.27 | 0.28 | 1.58 |
| <i>South.</i> | | | | | | | | | | | | | |
| Biggenden State Farm | 1.99 | 2.50 | 5.55 | 2.37 | 9.82 | 9.84 | 2.97 | 0.74 | 0.43 | 0.49 | 2.33 | 1.39 | 1.80 |
| Brisbane | 1.37 | 4.25 | 3.21 | 2.80 | 8.43 | 18.19 | 2.45 | 2.40 | 0.17 | 0.77 | 2.83 | 0.67 | 1.77 |
| Bundaberg | 1.70 | 2.90 | 2.99 | 4.77 | 2.82 | 7.35 | 4.13 | 0.67 | 0.39 | 0.75 | 1.56 | 1.10 | 2.39 |
| Dalby | 0.69 | 5.18 | 1.44 | 0.17 | 4.88 | 7.61 | 0.11 | 0.37 | 0.63 | 0.14 | 1.80 | 1.13 | 2.55 |
| Esk | 0.50 | 3.76 | 3.72 | 2.61 | 10.08 | 17.04 | 2.83 | 1.07 | 0.23 | 0.46 | 2.75 | 2.16 | 1.29 |
| Gatton Agric. College | 0.71 | 3.01 | 4.55 | ... | 3.38 | 10.74 | ... | 0.10 | 0.16 | 0.6 | 2.71 | 1.84 | 1.93 |
| Gympie | 1.20 | 3.05 | 5.49 | 6.26 | 11.77 | 8.03 | 1.87 | 2.00 | 0.38 | 1.16 | 2.87 | 1.37 | 2.49 |
| Ipswich | 0.78 | 4.45 | 3.40 | 1.32 | 6.63 | 13.77 | 2.71 | 1.14 | 0.12 | 0.47 | 3.23 | 1.19 | 1.48 |
| Maryborough | 2.74 | 3.49 | 5.81 | 5.62 | 8.07 | 11.40 | 2.52 | 1.05 | 0.46 | 0.81 | 1.98 | 1.05 | 1.84 |
| Roma | 1.04 | 3.70 | 2.51 | 0.04 | 6.38 | 2.51 | 0.22 | Nil | 0.55 | 0.63 | 1.38 | 1.12 | 2.15 |
| Roma State Farm | ... | ... | ... | ... | ... | ... | ... | ... | ... | 1.27 | 0.73 | ... | ... |
| Tewantin | 1.05 | 3.12 | 7.36 | 10.42 | 12.47 | 14.39 | 7.59 | 8.66 | 0.75 | 1.97 | 2.70 | 2.18 | 2.30 |
| Warwick | 1.37 | 3.25 | 3.13 | 0.76 | 4.52 | 6.65 | 1.40 | 0.15 | 0.80 | 1.24 | 2.99 | 1.96 | 0.96 |
| Westbrook State Farm | 1.08 | 4.76 | 3.23 | 0.43 | 8.03 | 1.41 | 1.40 | 0.05 | ... | 0.49 | 1.97 | ... | ... |
| Yandina | 1.44 | 2.87 | 3.05 | 8.37 | 14.47 | 16.62 | 5.45 | 4.59 | 0.58 | 2.64 | 2.18 | 1.50 | 3.10 |

NOTE.—The rainfall data in this table are compiled from telegraphic reports, and must be considered as approximate only.

GEORGE G. BOND,
Divisional Officer

ESK PASTORAL, AGRICULTURAL, AND INDUSTRIAL ASSOCIATION.

The next Annual Show of the above Society will be held on 4th May, 1909.

General Notes.

SPROUTED SEED POTATOES.

Three or four years ago, it was conclusively proved at the Queensland Agricultural College that seed potatoes which have been sprouted before planting, have come up more evenly, and have given better returns than seed which had not sprouted before sowing. The following item gives evidence of this:—Trials with respect to sprouted *v.* unsprouted seed potatoes were carried out for the Irish Department at sixty-seven centres in sixteen countries, the potatoes sprouted in boxes being for the main crop of late varieties. There was an average increase of 2 tons per acre from sprouting, and in every country the average showed more or less of an increase. In the four preceding seasons the increase due to sprouting has ranged from 1 ton 13 cwt. to 2 tons 13 cwt. No stronger testimony could be desired.

NEW ZEALAND HEMP INDUSTRY.

Speaking of the prospects of the hemp industry to a "News" representative lately, Mr. W. H. O. Johnson, the Government grader at Auckland, adopted a somewhat pessimistic tone. "Unless the price improves," he said, "I do not think that more than 25 per cent. of the millers will start operations—they cannot be expected to start if there is no prospect of a profit."

Asked whether there was any likelihood of an improvement, Mr. Johnson said the position entirely depended on the state of the Manila market; while the output was very large, the price was exceedingly low. On the other hand, if the price of Manila should rise, the manufacturers would at once turn to the New Zealand article. "Manila," said the expert, "can be much more cheaply put on the market, owing to the cheap labour that is available there. Although the Manila requires more handling, the low cost of production gives the millers there the advantage over local producers. Then Manila is a better fibre, and at a lower price is naturally sought after."

"Very little hemp is coming to hand," continued Mr. Johnson, "and it strikes me that many of the flax areas in this province will be the better for a year's rest. The only millers who will continue operations this year are those who are situated close to a railway or to steamers, and who can afford to put hemp on the market at a low price."

SOUTH BURNETT A. P. AND I. SOCIETY.

We are advised that the date of the next Kingaroy Annual Show has been fixed for Wednesday and Thursday, 28th and 29th April, 1909.

BIGGENDEN AGRICULTURAL AND PASTORAL SOCIETY.

The next Annual Show of the above society will be held on Thursday and Friday, 1st and 2nd July, 1909.

COCOA-NUTS IN CEYLON.

The area under cocoa-nut palms in Ceylon reaches about 680,000 acres, chiefly in gardens and plantations owned by natives. Tea comes next in importance as regards the area planted—viz., 390,000 acres. There are 34,000 acres under cacao, and about 120,000 acres planted with rubber. The rubber plantations are owned almost entirely by Europeans.

Answers to Correspondents.

AILING HORSE.

"BUNDA," Bundaberg—

The probability is, that your horse is suffering from some defect of his back teeth or molars. Mr. Sydney Dodd, Chief Veterinary Surgeon to the Department of Agriculture and Stock, recommends that you obtain the services of a practical man to examine the horse's teeth, and apply the necessary treatment, which consists of rasping the sharp edges off them, and then feeding the animal on soft food for a day or two.

TROUBLE AFTER CALVING.

E. DOSSEL, Mimerambi—

Your question was referred to Mr. Sydney Dodd, Principal Veterinary Surgeon, and his memorandum in reply was forwarded to you by the Under Secretary for Agriculture and Stock. The details are too long for insertion here.

DESTROYING BANDICOOTS.

A. MOSER, Aloomba—

The only remedies against bandicoots are shooting, trapping, poisoning by means of baits, such as sweet potatoes and strychnine, and wire-netting. A couple of sharp fox-terriers are also useful in keeping down the pests. A good bandicoot trap is figured in the Journal, Vol. XVIII., page 93 (February).

MANURING TOMATOES.

"BEGINNER," Mooloolah.—

A rich sandy loam, well drained and deeply ploughed, is the best for tomato culture. Tomatoes will not stand heavy manuring after the fruit has set, because either farmyard manure or other stimulating fertilisers delay the development and ripening of the fruit. A good manure is made up as follows:— 2 parts nitrate of soda, 2 parts of bone meal, 3 parts of kainit, 4 parts of superphosphate. Apply 1 oz. per square yard of soil weekly, slightly covering it. Apply from the time the plants are established until the fruit has set. The superphosphate has been found to hasten the maturing of the fruit.

BROOM MILLET.

BROOM MILLET, Bell.—

The so-called suckers should be removed by snapping them off at the point where they junction with the main stem, after they attain a length of from 9 to 12 inches. Bending down the heads is done for several reasons, one of which is to prevent twisted "hurl," but it must be understood that many heads will not require it. It is usually done when the seed head has left its protecting sheath and the seed has just formed. Leave 6 to 8 inches of stalk below the base of the fibre, and then with a deft movement of the thumb and finger turn the head gently over, care being taken not to snap it off. The seed, as it fills, will help to keep the fibre straight.

TOMATO CASE.

"ENGINEER."—

There is no regulation size for tomato cases in this State. The dimensions here given are those of the case which is most acceptable to the trade.

PINE CASE.

Twenty-eight inches long, outside measurement; ends, 6 inches deep; same width—or, in other words, 6 by 6, with a 6 by 6 centre piece. Top of the case should be in one piece.

"YOUNG DAIRYMAN," Cooroy.—

Your communication arrived after we had gone to Press. It will be published in the January issue of the Journal.

Times of Sunrise and Sunset at Brisbane, 1908.

| DATE. | SEPTEMBER. | | OCTOBER. | | NOVEMBER. | | DECEMBER. | | PHASES OF THE MOON.
H. M. |
|-------|------------|-------|----------|-------|-----------|-------|-----------|-------|-----------------------------------|
| | Rises. | Sets. | Rises. | Sets. | Rises. | Sets. | Rises. | Sets. | |
| 1 | 6·3 | 5·34 | 5·29 | 5·47 | 4·58 | 6·5 | 4·46 | 6·28 | 4 Sept. ☾ First Quarter 6 51 a.m. |
| 2 | 6·2 | 5·34 | 5·28 | 5·48 | 4·57 | 6·6 | 4·46 | 6·29 | 10 " ○ Full Moon 10 23 p.m. |
| 3 | 6·1 | 5·35 | 5·27 | 5·48 | 4·57 | 6·7 | 4·46 | 6·29 | 17 " ☽ Last Quarter 8 33 " |
| 4 | 5·59 | 5·35 | 5·25 | 5·49 | 4·56 | 6·8 | 4·46 | 6·30 | 26 " ● New Moon 0 59 a.m. |
| 5 | 5·58 | 5·35 | 5·24 | 5·49 | 4·55 | 6·8 | 4·46 | 6·31 | 3 Oct. ☾ First Quarter 4 14 p.m. |
| 6 | 5·57 | 5·36 | 5·23 | 5·50 | 4·55 | 6·9 | 4·46 | 6·32 | 10 " ○ Full Moon 7 3 a.m. |
| 7 | 5·56 | 5·36 | 5·22 | 5·50 | 4·54 | 6·10 | 4·46 | 6·32 | 17 " ☽ Last Quarter 1 35 p.m. |
| 8 | 5·55 | 5·37 | 5·21 | 5·51 | 4·53 | 6·10 | 4·46 | 6·33 | 25 " ● New Moon 4 47 " |
| 9 | 5·54 | 5·37 | 5·20 | 5·51 | 4·53 | 6·11 | 4·46 | 6·34 | 3 Nov. ☾ First Quarter 0 16 a.m. |
| 10 | 5·53 | 5·38 | 5·19 | 5·52 | 4·52 | 6·12 | 4·47 | 6·35 | 8 " ○ Full Moon 5 58 p.m. |
| 11 | 5·52 | 5·38 | 5·18 | 5·52 | 4·52 | 6·13 | 4·47 | 6·35 | 16 " ☽ Last Quarter 9 41 a.m. |
| 12 | 5·51 | 5·39 | 5·17 | 5·53 | 4·51 | 6·13 | 4·47 | 6·36 | 24 " ● New Moon 7 53 " |
| 13 | 5·49 | 5·39 | 5·16 | 5·54 | 4·51 | 6·14 | 4·47 | 6·36 | 2 Nov. ☾ First Quarter 0 16 a.m. |
| 14 | 5·48 | 5·39 | 5·15 | 5·54 | 4·50 | 6·15 | 4·48 | 6·37 | 8 " ○ Full Moon 5 58 p.m. |
| 15 | 5·47 | 5·40 | 5·13 | 5·55 | 4·50 | 6·16 | 4·48 | 6·38 | 16 " ☽ Last Quarter 9 41 a.m. |
| 16 | 5·46 | 5·40 | 5·12 | 5·55 | 4·49 | 6·16 | 4·48 | 6·38 | 24 " ● New Moon 7 53 " |
| 17 | 5·45 | 5·41 | 5·11 | 5·56 | 4·48 | 6·17 | 4·49 | 6·39 | 2 Dec. ☾ First Quarter 7 44 a.m. |
| 18 | 5·43 | 5·41 | 5·10 | 5·56 | 4·48 | 6·18 | 4·49 | 6·40 | 8 " ○ Full Moon 7 44 " |
| 19 | 5·42 | 5·42 | 5·9 | 5·57 | 4·48 | 6·19 | 4·49 | 6·40 | 16 " ☽ Last Quarter 7 12 " |
| 20 | 5·41 | 5·42 | 5·9 | 5·58 | 4·48 | 6·20 | 4·50 | 6·41 | 23 " ● New Moon 9 50 p.m. |
| 21 | 5·40 | 5·43 | 5·8 | 5·58 | 4·47 | 6·20 | 4·50 | 6·41 | 30 " ☾ First Quarter 3 40 " |
| 22 | 5·39 | 5·43 | 5·7 | 5·59 | 4·47 | 6·21 | 4·51 | 6·42 | |
| 23 | 5·38 | 5·44 | 5·6 | 5·59 | 4·47 | 6·22 | 4·51 | 6·42 | |
| 24 | 5·37 | 5·44 | 5·5 | 6·0 | 4·47 | 6·23 | 4·52 | 6·43 | |
| 25 | 5·35 | 5·44 | 5·4 | 6·1 | 4·46 | 6·23 | 4·53 | 6·43 | |
| 26 | 5·34 | 5·45 | 5·3 | 6·1 | 4·46 | 6·24 | 4·53 | 6·44 | |
| 27 | 5·33 | 5·45 | 5·2 | 6·2 | 4·46 | 6·25 | 4·54 | 6·44 | |
| 28 | 5·32 | 5·46 | 5·1 | 6·3 | 4·46 | 6·26 | 4·54 | 6·44 | |
| 29 | 5·31 | 5·46 | 5·1 | 6·3 | 4·46 | 6·26 | 4·55 | 6·45 | |
| 30 | 5·30 | 5·47 | 5·0 | 6·4 | 4·46 | 6·27 | 4·55 | 6·45 | |
| 31 | ... | ... | 4·59 | 6·5 | ... | ... | 4·56 | 6·46 | |

The Markets.

PRICES FOR FRUIT—ROMA-STREET MARKETS.

| Article. | OCTOBER. | |
|--|---------------------|-----|
| | Prices. | |
| Apples, per case | ... | ... |
| Apples (Hobart), per case | 6s. to 11s. | ... |
| Apples (American), per case | ... | ... |
| Asparagus (Westbrook State Farm), per dozen bundles | ... | ... |
| Bananas (Cavendish), per dozen | 3d. to 3½d. | ... |
| Bananas (sugar) | 1½d. to 2½d. | ... |
| Custard Apples, per case | ... | ... |
| Gooseberries, per quarter-case | ... | ... |
| Lemons, per case | 5s. to 7s. | ... |
| Lemons, rough, per case | ... | ... |
| Loquats (Sydney), per case | ... | ... |
| Mandarins, per case | 8s. to 12s. | ... |
| Mangoes, per case | ... | ... |
| Oranges, per case | 7s. 6d. to 9s. | ... |
| Passion Fruit, per quarter-case | 4s. to 6s. | ... |
| Papaw Apples, per quarter-case | 2s. 6d. to 3s. 6d. | ... |
| Persimmons, per case | 2s. 6d. to 5s. | ... |
| Pineapples (Ripley's), per dozen | 4s. to 9s. 6d. | ... |
| Pineapples, rough, per dozen | 6d. to 5s. | ... |
| Pineapples, smooth, per dozen | 5s. 6d. to 10s. 6d. | ... |
| Rosellas, per sugar bag | ... | ... |
| Strawberries, per dozen boxes | 4s. to 10s. | ... |
| Tomatoes, per quarter-case | 1s. 6d. to 5s. | ... |
| Tomatoes (spotted), per quarter-case | ... | ... |
| Tomatoes (prime), per quarter-case | ... | ... |

SOUTHERN FRUIT MARKET.

| | |
|--|--------------------|
| Apples (Hobart) per case | 10s. to 10s. 6d. |
| Apples, American, per case | 10s. to 15s. |
| Apples, Baldwins, per case | 14s. |
| Apricots, per box | 5s. to 7s. |
| Bananas, Queensland, per bunch | 3s. 6d. to 5s. 6d. |
| Bananas, Queensland, per case | 14s. 6d. to 15s. |
| Cherries, per 12-lb. box | 9s. to 12s. |
| Lemons, per case | 12s. |
| Loquats, per case | 5s. |
| Mandarins (Local), per case | 16s. |
| Mandarins, Emperor, per case | ... |
| Oranges (Local), per case | 12s. |
| Oranges, Navel, per case | 15s. |
| Passion Fruit, per quarter-case | 7s. |
| Passion Fruit (medium), per case | ... |
| Passion Fruit (small), per case | ... |
| Peaches, China, per case | 5s. to 7s. |
| Pears, American, per half-box | 7s. to 7s. 6d. |
| Pineapples (common), choice, per case | 9s. to 11s. |
| Pineapples (common), good, per case | 7s. to 8s. 6d. |
| Pineapples (Ripley Queen), per case | 9s. to 11s. |
| Pineapples (Queen's), per case | 9s. to 11s. |
| Strawberries (small and inferior), per three-quart tray | ... |
| Tomatoes, Queensland, choice (coloured), per quarter-case | 6s. to 7s. |
| Tomatoes, good, per quarter-case | ... |
| Tomatoes, small | ... |

Orchard Notes for January.

By ALBERT H. BENSON, M.R.A.C.

THE SOUTHERN COAST DISTRICTS.

The fruit of the month in this part of the State is the grape, and its gathering and marketing will occupy the attention of growers. Care should be taken to cut the fruit when cool and dry, and if it has to be sent any distance the stems of the bunches should be allowed to wilt before the fruit is packed, as the berries will thus hang on to the bunch better, and the bunch carry in better order. Select the fruit carefully, grade it, and pack firmly so that it will not bruise in transit. If to be sent long distances, pack in crates holding from four to six 6-lb. baskets. Pines will be ripening in quantity towards the end of the month. Gather before fully coloured, and, whether for Southern or local markets, pack and handle carefully to prevent bruising. Do not ship the fruit too green for the Southern markets, as doing so is apt to spoil the trade. Send good fruit to the canneries. Small pines and crippled fruit are no good to canners, and the sooner our growers realise that it only pays to grow good fruit the better for them and for the canners, as if the latter cannot get good fruit it is impossible for them to put a line of goods that will not only be a credit to the State, but for which a world-wide market can be obtained.

Passion fruit should not be allowed to lie about for days on the ground before gathering, as if so they are apt to become fly-infested.

Water melons and rock melons are still in season.

Watch any late peaches, Japanese plum, or other fruits liable to be infested with the fruit fly, and gather and destroy all infested fruit, or, better still, grub the trees out and burn them, as they only breed flies to destroy more valuable fruit. Mangoes will be ripening during the month. See that all fly-infested fruits are destroyed, as they will only breed up further crops to destroy later ripening fruits.

Citrus orchards can be cyanided during the month for scale insects, and spraying for Maori with the sulphide of soda wash should be continued where necessary.

Mangoes can be budded during the month as well as citrus and deciduous trees. Tropical fruit trees can be transplanted, taking care to choose dull weather and to cover same from the direct rays of the sun till they have become firmly established. Pines and bananas can still be planted.

TROPICAL COAST DISTRICTS.

See that all bananas are covered with netting, as the fly is usually at its worst at this time of year.

Mangoes will be going off. See that they are not allowed to remain about on the ground to breed flies for the Autumn crop of oranges. Longan, litchi, and other fruit are in season. As the month is often a very wet one, little cultivation can be done in the orchards. Strong undergrowth should, however, be kept down with a hoe or scythe. Tropical fruits of all sorts can be planted. Look out for Maori on citrus fruits, and spray when necessary.

SOUTHERN AND CENTRAL TABLELANDS.

January is a busy month in the Stanthorpe district, apples, pears, plums, peaches, and nectarines being in season. Do not gather the fruit too immature, at the same time do not allow it to be over-ripe. Gather dry, handle carefully, grade and pack in attractive cases. Keep the fruit as cool as possible,

and ship in well-ventilated cars. Keep a sharp look-out for fruit fly, and take every possible means to prevent its spreading, even going so far as to gather and destroy the whole of the fruit on any infested trees, as if kept in check during the month the bulk of the fruit ripening during February will be free.

Keep a sharp look-out also for codling moth, examine the bandages on the trees at least every ten days, and destroy all larvæ found therein, also gather and destroy all moth-infested fruit.

Gather Bartlett pears as soon as they are large enough, and store away in a cool shed to ripen; when they show signs of ripening, market, not before. If sent down green they will sell for cooking, and only fetch a small price. The right stage at which to gather is when the fruit is fully developed, and the flesh has lost its woody flavour but is still quite hard. This is usually before the fly has stung it, and if gathered at this stage the fruit will ripen up properly without shrivelling and develop its full flavour.

These remarks apply also to the Downs country, which is somewhat earlier than Stanthorpe.

The crop of the month in the Western tablelands is the grape; and the remarks I have made respecting this fruit when grown in the Southern Coast Districts apply equally here. The fruit should be gathered dry, and wilted before it is packed. Too large cases are often used, cases holding from 20 to 30 lb., or crates holding six 6-lb. baskets are preferable; the latter being the best package for shipping the fruit long distances. Keep the orchards well cultivated, and, when water for irrigation is available, give citrus trees a watering during the month, unless there has been a sufficient rainfall. When the orchard is irrigated, see that thorough cultivation follows the irrigation, so as to conserve the moisture in the soil.

Red Scale, which is prevalent on citrus fruits in the dry Western country, should be treated during the month. Cyaniding is the best remedy.

Farm and Garden Notes for January.

FIELD.—The main business of the field during this month will be ploughing and preparing the land for the potato and other future crops, and keeping all growing crops clean. Never allow weeds to seed. This may be unavoidable in the event of long-continued heavy rains, but every effort should be made to prevent the weeds coming to maturity. A little maize may still be sown for a late crop. Sow sorghum, imphee, Cape barley, vetches, panicum, teosinte, rye, and cowpeas. In some very early localities potatoes may be sown, but there is considerable risk in sowing during this month, and it may be looked upon merely as an experiment. Plant potatoes whole.

KITCHEN GARDEN.—A first sowing of cabbages, cauliflower, and Brussels sprouts may now be made in a covered seed bed, which must be well watered and carefully protected from insect pests. Sow in narrow shallow drills; they will thus grow more sturdy, and will be easier to transplant than if they were sown broadcast. The main points to be attended to in this early sowing are shading and watering. Give the beds a good soaking every evening. Mulching and a slight dressing of salt will be found of great benefit. Mulch may consist of stable litter, straw, grass, or dead leaves. Dig over all unoccupied land, and turn under all green refuse, as this forms a valuable manure. Turn over the heavy land, breaking the lumps roughly to improve the texture of the soil by exposure to the sun, wind, and rain. In favourable weather sow

French beans, cress, cauliflowers, mustard, cabbage, celery, radish, for Autumn and Winter use. Sow celery in shallow, well-drained boxes or in small beds, which must be shaded till the plants are well up. Parsley may be sown in the same manner. Turnips, carrots, peas, and endive may also be sown, as well as a few cucumber and melon seeds for a late crop. The latter are, however, unlikely to succeed except in very favourable situations. Transplant any cabbages or cauliflowers which may be ready. We do not, however, advise such early planting of these vegetables, because the fly is most troublesome in February. For preference, we should defer sowing until March. Still, as "the early bird catches the worm," it is advisable to try and be first in the field with all vegetables, as prices then rule high. Cucumbers, melons, and marrows will be in full bearing, and all fruit as it ripens should be gathered, whether wanted or not, as the productiveness of the vines is decreased by the ripe fruit being left on them. Gather herbs for drying, also garlic, onions, and eschallots, as the tops lie down.

FLOWER GARDEN.—To make the flower beds gay and attractive during the Autumn and Winter months is not a matter of great difficulty. Prepare a few shallow boxes. Make a compost, a great part of which should consist of rotten leaves. Fill the boxes with the compost, then sow thinly the seeds of annuals. Keep the surface of the soil moist, and when the young seedlings are large enough to handle lift them gently one by one, with a knife or a zinc label—*never pull them up by hand*, as, by so doing, the tender rootlets are broken, and little soil will adhere to the roots. Then prick them out into beds or boxes of very light soil containing plenty of leaf-mould. Then keep a sharp lookout for slugs and caterpillars. Keep a supply of tobacco dust on hand, and scatter this in the path of the slug, and he will cease from troubling you.

All kinds of shrubby plants may be propagated by cuttings. Thus, pelargoniums, crotons, coleus, and many kinds of tropical foliage plants can be obtained from cuttings made this month. After putting out cuttings in a propagating frame, shade them with a piece of calico stretched over it. Be careful not to over-water at this season. Propagate verbenas, not forgetting to include the large scarlet Foxhunter. Verbenas require rich soil. Palms may be planted out this month. If the weather prove dry, shade all trees planted out. With seed boxes, mulch, shade, water, and kerosene spray, all of which imply a certain amount of morning and evening work. The flower garden in Autumn and Winter will present a charming sight, and will afford light and profitable work for girls with spare time on their hands.



THE
QUEENSLAND AGRICULTURAL JOURNAL,

ISSUED BY DIRECTION OF

THE HON. THE SECRETARY FOR AGRICULTURE.

EDITED BY A. J. BOYD F.R.G.S.Q.

VOLUME XXII.

JANUARY TO JUNE, 1909.

BRISBANE:

BY AUTHORITY: ANTHONY JAMES CUMMING, GOVERNMENT PRINTER, WILLIAM STREET.

1909.

QUEENSLAND AGRICULTURAL JOURNAL.

VOL. XXII., PARTS 1-6.

GENERAL INDEX.

| | Page. | | Page. |
|---|-----------------------------|--|-------------------|
| A. | | Bee, The Pumpkin, Destruction of the | 39, 111 |
| A Codlin Moth Parasite | 44 | Beetles, Tomato | 205 |
| A Curious Cow | 297 | Best Pork-producing Ration | 142 |
| A Fine Pear Tree | 309 | Biggenden State Farm | 130 |
| A Large Station | 146 | Bird, A Sparrow-destroying | 42 |
| A Lost Orchid Rediscovered | 303 | Blight in Cattle, Cure for | 204 |
| A New Casein Test | 142 | Boll-worm, the Cotton, To Combat | 179 |
| A New Double-headed Wheat | 139 | Bones, Fractured, in Dogs | 320 |
| A New Fibre-extracting Machine | 263 | Bordeaux Mixture, A New | 83 |
| A New Mango | 84 | Boring a Hole through Glass | 109 |
| A New Valuable Clover | 126 | Boring Insects | 109 |
| A Novel Mouse-trap | 102 | Botany | 28, 147, 187, 316 |
| A Prolific Wheat | 125 | British New Guinea as a Planting Country | 32 |
| A Rusty Tank, How to Treat | 267 | Broken Bones of Horses | 143 |
| A Seventy-five Bushel Wheat Crop | 4 | Broken Bones of Dogs | 320 |
| A Story of Two Cows | 12 | Broodiness in Hens, To Cure | 185 |
| A Water-weed Cutter | 45 | Bull, Choosing a Dairy | 140 |
| Abortion, Contagious | 317 | Burning out Stumps | 321 |
| Acacias and Poincianas | 267 | Butter, Export of | 12 |
| Acre of Land, Quantity of Seed Potatoes Required to Plant an | 179 | Butter Boxes, Straw | 297 |
| Acute Tympanites (Hoven or Blown) | 103 | Butter, The Value of Grading | 295 |
| Agricultural Credit Banks | 230 | Buying Poultry | 269 |
| Agriculture | 1, 55, 117, 175, 219, 275 | | |
| An American's Address to Farmers' Boys | 134 | C. | |
| An Enormous Grapevine | 186 | Calendar of Flower-gardening | 24 |
| Analyses of Ensilage | 195 | Candle-nut Tree | 37 |
| Analyses of Dip Fluids | X1 | Cane Farmers, Subsidiary Crops for | 95 |
| Analyses of Fertilisers | 260 | Cane Harvester, The "Pessou" | 99 |
| Analyses of Spear, and Blue Grasses and Molasses | 268 | Care of Horses | 238 |
| Analysis of Carrots | 168 | Carrots, Analysis of | 168 |
| Analysis of <i>Phalaris commutata</i> | 228 | Carayonica Cotton | 164 |
| Analysis, Rough, of Soils | 324 | Casein Test, A New | 142 |
| Angora Goats | 65 | Cassava, Cultivation of | 310 |
| Animal Pathology | 103 | Cassava as a Food-stuff | 47 |
| Another Drought Predicted | 41 | Caterpillars, Destroying | 299 |
| Another New Clover | 139 | Cattle, Cure for Blight in | 204 |
| Answers to Correspondents | 46, 109, 167, 205, 267, 324 | Coment from Soap Waste | 93 |
| Apiculture | 30, 85, 152 | Cereals, Winter, Experiments with at the State Farm, Roma | 117 |
| Apples, Codlin Moth-proof | 151 | Chemistry | 228, 260, 268 |
| Apricot-growing in Brisbane | 19 | China, Forests of | 255 |
| Arrowroot-growing in Queensland | 1, 59 | China, Frozen Pigs from | 205 |
| Asparagus, Winter | 233 | Choosing a Dairy Bull | 140 |
| Australian Honey in London | 85 | Chopped Sugar-cane as Fodder | 110 |
| "Australian Sugar Journal" | 239 | Clipping Horses | 69 |
| | | Clover Plant, A New Valuable | 123 |
| B. | | Clover Plant, Another New | 139 |
| Banana Margerine | 322 | Clover, Tropical | 268 |
| Banks, Agricultural Credit | 230 | Coal Tar for Pumpkin-beetles | 166 |
| Bedrooms, Plants in | 44 | Coast Lands, Wheat-growing on | 176 |
| Beating the Fruit Fly | 83 | Cocoanut Culture | 196 |
| Bee Notes | 30, 85 | Cocoanut-planting in Samoa | 37 |
| | | Codlin Moth, Fighting the | 151 |
| | | Codlin Moth Parasite | 44 |

| | Page. | | Page. |
|---|-----------------------------|---|-----------------------------|
| Codlin Moth-proof Apples ... | 151 | Ensilage, Analyses of ... | 195 |
| Common Sense in the Poultry-yard ... | 74 | Entomology ... | 39 |
| Commonwealth, Official Year-book of the | | Erection of Piggeries, Specifications for ... | 234 |
| Concrete, Reinforced ... | 106 | Eri Silk ... | 86 |
| Contagious Abortion ... | 317 | Erosion of Hill Lands ... | 292 |
| Contributions to the Flora of Queens- | | Exhausted Soils ... | 177 |
| land and New Guinea ... | 28, 147, 187, 316 | Experiments with Rubber Seeds ... | 98 |
| Cork Waste ... | 82 | Experiments with Winter Cereals at the | |
| Corn Judging ... | 226 | Roma State Farm ... | 117 |
| Correspondents, Answers to ... | 46, 109, 187, 205, 324 | Export, Grapes for ... | 79 |
| Cost of Fertilisers for Maize ... | 325 | Export of Butter ... | 12 |
| Cotton Boll-worm, To Combat the ... | 179 | Export of Fruit from South Africa ... | 19 |
| Cotton, Caravonica ... | 164 | Extermination of Sparrows ... | 41 |
| Cotton from Normanton ... | 48 | Extraction of Oil from Seeds ... | 262 |
| Cotton-growing ... | 135 | | |
| Cotton-picking ... | 94 | F. | |
| Cotton, Method of Estimating the Yield | | Facts and Fancies of the Garden ... | 249 |
| of in the Field ... | 229 | Failure of a Potato Crop ... | 111 |
| Cow, A Curious ... | 297 | Farm and Garden Notes ... | 51, 114, 172, 210, 273, 329 |
| Cow, Daily feeding Ration for ... | 293 | Farm Crops as Food for Stock ... | 126 |
| Cow, The Hereford as a Dairy Breed ... | 10 | Farm Produce, Prices of in the Brisbane | |
| Cow, What a good Cow should yield ... | 322 | Markets ... | 50, 113, 170, 207, 270, 328 |
| Cows, A Story of Two ... | 12 | Farmers' Boys, An American's Address | |
| Cows, Dehorning ... | 296 | to ... | 134 |
| Creation of a New Strawberry ... | 267 | Farmers, Notes for, on the Fibre | |
| Crop, Failure of the Potato ... | 111 | Industry ... | 315 |
| Crops at "Hermitage" State Farm ... | 60 | Farming, Dry, in New South Wales ... | 4 |
| Crops, Farm, As Food for Stock ... | 126 | Farms, State Poultry, in New Zealand ... | 15 |
| Crops, Rotation of ... | 130 | Farms, Demonstration, in the United | |
| Crops, Subsidiary for Cane Farmers ... | 95 | States ... | 30 |
| Crystallising Fruit ... | 68 | Farmyard Manure ... | 132 |
| Cultivation of the Peanut ... | 285 | Fattening Young Fowls ... | 240 |
| Cultivation of the Potato ... | 278 | Feed and Richness of Milk ... | 184 |
| Cultivation, Marvels of ... | 105 | Feeding Rations daily, for Cows ... | 293 |
| Cure for Blight in Cattle ... | 204 | Fences, Wire ... | 167 |
| Cure for Broodiness in Hens ... | 185 | Fertilisers, Analyses of ... | 260 |
| Cure for Tick Poison ... | 105 | Fertilisers for Maize, Cost of ... | 325 |
| Cure for Warts in Poultry ... | 168 | Fertilising Small Gardens ... | 201 |
| Curing Bacon and Hams ... | 141 | Fibre-extracting Machine, A New ... | 263 |
| Cutworms ... | 99 | Fibre Industry, Notes for Farmers on | |
| | | the ... | 315 |
| D. | | Fibre Plant, A New ... | 201 |
| Daily Feeding Ration for Milch Cows ... | 293 | Fibres, The Market for ... | 84 |
| Dairy Produce Acts 1904 to 1905 ... | 63 | Fighting the Codlin Moth ... | 151 |
| Dairy Breed, The Hereford Cow as a ... | 10 | First Sheep in Australia ... | 166 |
| Dairy Bull, Choosing a ... | 140 | Flax Industry ... | 322 |
| Dairy Herd, Queensland Agricultural | | Flax Mills in New Zealand ... | 153 |
| College ... | 10, 68, 140, 180, 234, 293 | Flora of Queensland and New Guinea, | |
| Dairying ... | 10, 62, 140, 180, 234, 293 | Contributions to the ... | 28, 147, 187, 316 |
| Darling Pea ... | 47 | Florida, Pineapple-growing in ... | 16 |
| Darnel or Drake ... | 4 | Flower-gardening ... | 20, 88, 154, 188, 244, 301 |
| Dehorning Cows ... | 296 | Flower-gardening Calendar ... | 24 |
| Demand for Sisal Fibre ... | 164 | Forests and Moisture ... | 256 |
| Demonstration Farms in the United | | Forestry ... | 71, 255 |
| States ... | 30 | Forests of China ... | 255 |
| Destroying Caterpillars ... | 299 | Forests of Japan ... | 71 |
| Destruction of Grasshoppers ... | 276 | Fowls, Laying, Oats for ... | 324 |
| Destruction of Prickly Pear ... | 264 | Fowls, Sweet Potatoes for ... | 324 |
| Destruction of the Pumpkin Beetle ... | 39 | Fractured Bones of Dogs ... | 320 |
| Dingo-trapping ... | 202 | Frozen Pigs from China ... | 205 |
| Disc-harrowing Lucerne ... | 179 | Fruit Cases ... | 83 |
| Diseases of Poultry ... | 145 | Fruit, Export of, from South Africa ... | 19 |
| Distribution of Improved Seed Wheat ... | 219 | Fruit Fly, Beating the ... | 83 |
| Ditch Millet ... | 268 | Fruit, Sulphur Fumes for Preserving ... | 151 |
| Double-headed Wheat, A New ... | 139 | Fruits, To Crystallise ... | 68 |
| Dogs, Fractured Bones in ... | 320 | Fruit, How to Pulp ... | 242 |
| Do Hens get too fat to Lay? ... | 240 | Fruit Market, The Southern ... | 49, 112, 169, 206, 269, 327 |
| Dried Blood for Laying Hens ... | 324 | Fruit, Prices for in the Turbot Street | |
| Dry Farming in New South Wales ... | 4 | Markets ... | 49, 112, 169, 206, 269, 327 |
| | | G. | |
| E. | | Gall, Nematode Root ... | 100 |
| Endurance of Ponies ... | 186 | Garden, Destroying Mice in the ... | 323 |
| Enoggera Sales ... | 50, 113, 170, 207, 270, 328 | Gardens, Fertilising Small ... | 201 |
| Enormous Grapevine ... | 186 | | |

GENERAL INDEX.

v.

| | Page. |
|---|-------|
| Gardening Calendar | 24 |
| Garlic for Tick Fever | 104 |
| General Notes ... 41, 105, 166, 202, 265, | 320 |
| Gorman E. Africa, Sisal Hemp in ... | 94 |
| "Glenthorne Monarch" | 71 |
| Glass, To Bore a Hole Through ... | 109 |
| Goats, Angora | 65 |
| Grading Butter, The Value of ... | 295 |
| Grain in Bin and Granary, Insects | |
| Destructive to | 39 |
| Grapes for Export | 79 |
| Grapevine, An Enormous | 186 |
| Grasshopper Destruction in South Africa | 276 |
| Grasshopper in Queensland | 278 |
| Gripes in Horses | 300 |

H.

| | |
|---|-------------------|
| Hemp, Manila, Machine for Extracting | 313 |
| Hemp, Sisal in German East Africa ... | 94 |
| Hens, Do they get too fat to Lay? ... | 240 |
| Hens, Laying, Dried Blood for | 324 |
| Hens, Laying, Oats for | 324 |
| Hens, Old, for the Table | 14, 77 |
| Hereford Cow as a Dairy Breed | 10 |
| "Hermitage" State Farm, Crops at the | 60 |
| "Hermitage" State Farm, Merino Sheep | |
| at the | 4 |
| High Prices for Ostriches | 15 |
| Honey, Australian in England | 85 |
| Honey Paste for Labels | 185 |
| Honey, Prospects of an Export Trade in | 152 |
| Honey, Some Uses for | 153 |
| Horses | 69, 143, 238, 300 |
| Horses, Broken Bones of | 143 |
| Horses, Care of | 238 |
| Horses, Clipping | 69 |
| Horses not Lying down | 69 |
| Horses, Gripes in | 300 |
| Horses, Ringworm in | 267, 300 |
| Horses, Sweet Potato Vines for | 300 |
| Horticulture ... 20, 88, 154, 188, 244, | 301 |
| Hot Bearing | 108 |
| Hoven or Blown | 103 |
| How to Pulp Fruit | 342 |
| How to Treat a Rusty Tank | 267 |
| How to Vanquish the Mosquito | 43 |

I.

| | |
|---|-----|
| Improved Seed-wheat, Distribution of ... | 219 |
| In-breeding (Poultry) | 77 |
| Industries, Tropical ... 31, 94, 164, 196, 262, | 310 |
| Insects, Boring | 109 |
| Insects Destructive to Grain in Bin and | |
| Granary | 39 |

J.

| | |
|---|-----|
| Japan, The Forests of | 71 |
| Judging Corn | 226 |
| Judging Wheat, Rules for | 229 |
| Judging Stock, Practical Instruction in | 135 |
| June, Farm and Garden Notes for ... | 273 |
| June, Orchard Notes for | 271 |

K.

| | |
|--------------|---------|
| Kapok | 97, 109 |
|--------------|---------|

L.

| | |
|-------------------------------------|-----|
| Labels, Honey Paste for | 185 |
| Land Erosion | 232 |
| Laying Hens, Dried Blood for | 324 |

| | Page. |
|-----------------------------------|-------|
| Laying Hens, Oats for | 324 |
| Lettuce Running to Seed | 134 |
| Local Shows, The Value of | 5 |
| Lucerne, Disc-harrowing of | 179 |
| Lucerne-growing | 55 |

M.

| | |
|--|----------|
| Machine, A New Fibre-extracting | 263, 313 |
| Maize, Cost of Fertilisers for | 325 |
| Maize Culture | 220 |
| Mango, A New | 84 |
| Manure, Farmyard | 132 |
| Manuring for Milk | 180 |
| March, Farm and Garden Notes for ... | 114 |
| March, Orchard Notes for | 115 |
| Margerine, Banana | 322 |
| Market for Fibres | 84 |
| Marketing Poultry | 72 |
| Markets ... 49, 112, 169, 266, 269, | 327 |
| Marvels of Cultivation | 105 |
| May, Farm and Garden Notes for ... | 210 |
| May, Orchard Notes for | 208 |
| Mead | 153 |
| Merino Sheep at the "Hermitage State | |
| Farm | 4 |
| Method of Estimating the Yield of | |
| Cotton in the Field | 229 |
| Mexico, the Pulque Maguey of | 31 |
| Mice in the Garden, To Destroy | 323 |
| Mildew, Onion | 59 |
| Milk, Manuring for | 180 |
| Milk, Richness of, and Feed | 184 |
| Millet, Ditch | 268 |
| Molasses, Spear and Blue Grass, Analy- | |
| ses of | 268 |
| Mosquito, How to Vanquish the | 43 |
| Moths, Trapping | 243 |
| Mouse-trap, A Novel | 102, 323 |

N.

| | |
|--|----------|
| National Association, A Proposed | |
| Chamber of Agricultural Societies ... | 9 |
| Nematode Root Gall | 100 |
| New Bordeaux Mixture | 83 |
| New Casein Test | 142 |
| New Fibre-extracting Machine | 263 |
| New Fibre Plant | 201 |
| New Guinea, British, as a Planting | |
| Country | 32, 33 |
| New Guinea, Contributions to the Flora | |
| of | 147 |
| New Mango | 84 |
| New South Wales, Dry Farming in ... | 4 |
| New Valuable Clover Plant | 126, 139 |
| New Zealand Flax Mills | 153 |
| New Zealand, State Poultry Farms in ... | 15 |
| Normanton, Cotton from | 48 |
| Notes, Bee | 30, 85 |
| Notes, Farm and Garden ... 51, 114, 172, | 210, |
| 273, 329 | |
| Notes for Farmers on the Fibre Industry | 315 |
| Notes, General ... 41, 105, 166, 202, 265, | 320 |
| Notes, Orchard ... 52, 115, 171, 208, | 271, 330 |
| Notes, Ostrich | 13 |
| Novel Mouse-trap | 102 |

O.

| | |
|--|--------|
| Oats for Laying Hens | 324 |
| Official Year-book of the Commonwealth | 326 |
| Oil, Extraction of, from Seeds | 262 |
| Old Hens for the Table | 14, 77 |
| Onion Mildew | 59 |
| Onions, Seed | 184 |

| T. | Page. | V. | Page. |
|--|----------------------------|--|--------|
| Tank, An Underground | 109 | Value of Grading Butter | 295 |
| Tank, How to Treat a Rusty | 267 | Value of Local Shows | 5 |
| Teeswater Sheep | 59 | | |
| The Candle-nut Tree | 37 | W. | |
| The Darling Pea | 47 | Washington Whitewash | 292 |
| The First Sheep in Australia | 166 | Watermelons, To Tell When Ripe | 324 |
| The Hereford Cow as a Dairy Breed | 10 | Water-weed Cutter | 45 |
| The Pulque Maguay of Mexico | 31 | Weevil, The Sweet Potato | 107 |
| The Spider Pea | 237 | What not Advertising Cost Him | 166 |
| The Tuberculin Test | 62 | What a Good Milch Cow should Yield | 322 |
| The Value of Local Shows | 5 | Wheat, A Prolific | 125 |
| Tick Fever, Garlic for | 104 | Wheat Crop, A Seventy-five Bushel | 4 |
| Tick Poison, Cure for | 105 | Wheat, A New Double-eared | 139 |
| Times of Sunrise and Sunset at Brisbane | 38, | Wheat-growing on Coast Lands | 176 |
| | 108, 163, 193, 259, | Wheat, An Improved Seed | 219 |
| | 331 | Wheat, The Rise in, and its Justification | 275 |
| To Destroy Mice in the Garden | 323 | Wheats at the State Farm, "Hermitage" | 60 |
| To Fatten Young Fowls | 240 | Wheats at the State Farm, Roma | 7, 152 |
| To Find the Composition of Soils | 324 | Windmills | 202 |
| To Measure the Quantity of Water | | Winter Asparagus | 233 |
| Available in a Stream | 46 | Wire Fences | 167 |
| To Tell When Watermelons are Ripe | 324 | Worms in Figs | 165 |
| Tomato Beetles | 205 | | |
| Trapping Moths | 243 | Y. | |
| Tropical Clover | 268 | Year-book, Official, of the Common- | |
| Tropical Industries | 31, 94, 164, 196, 262, 310 | wealth for 1901 to 1908, Nos. 1 and 2 | 326 |
| Two Cows, A Story of | 12 | | |
| Tympanites, Acute (Hoven) | 103 | | |
| | | | |
| U. | | | |
| Underground Tank | 109 | | |
| Uses for Honey | 152 | | |

Agriculture.

ARROWROOT-GROWING IN QUEENSLAND.

The cultivation of arrowroot in this State dates back to 1861. It was then grown at Oxley Creek by Major A. J. Boyd, who manufactured the commercial article by the primitive process of grating the bulbs and purifying the starch by straining it several times through linen stretched over tubs. The product was then readily sold at 1s. per lb. Later on Mr. Boyd sold the bulbs to Mr. Grimes, who also grew arrowroot at Oxley and on the Brisbane River, where he erected the first arrowroot mill installed in the State. The bulbs were sold at £2 10s. per ton; and on the then virgin scrub soils between Oxley Creek and Rocklea, or Rocky Water Holes as the place was then called, the return was enormous. Mr. Grimes grew both the *Maranta* and the *Canna edulis*, but the former, owing to the small production of bulbs, was found not to be profitable.

At the present day all the arrowroot manufactured in Queensland is produced in the Albert, Pimpama, and Nerang districts. At Pimpama the Messrs. Lahey had extensive plantations and a well-equipped manufactory. Ormeau, where a considerable quantity of arrowroot is grown, was taken up under the old "Sugar and Coffee Regulations," by Major Boyd, who erected a sugar mill and grew cane for several years. He named his plantation "Ormeau," hence the name of the railway station on the South Coast line. A very interesting account of the arrowroot industry, by H. N. L.—presumably Mr. Leahy—appeared in the "Brisbane Courier" of 17th October last, and we reproduce it as showing the rise and progress of the industry since its initiation:—

GROWERS AND PRICES.

At present the growers are all situated about Yatala, Pimpama, Ormeau, and Nerang, and the principal ones are Messrs. J. Latimer and Sons, Doherty Bros., R. Doherty, Mayes, W. Murtha, Mills, J. Bull, and Mrs. Clarke. The total area under cultivation is about 200 acres, and Messrs. Doherty Bros. and R. Doherty are the largest growers, having between them about 100 acres, while Messrs. Latimer Bros., at Nerang, have 35 acres. The other growers cultivate 10 to 15 acres each of this product. The yield of the marketable product ranges from 15 to 30 cwt. per acre, and the total production is about 600,000 lb., or just the same as was estimated by Mr. Samuel Grimes, in an article written by him on arrowroot cultivation in 1888.

The price to the grower varies considerably. Two years ago it brought about £10 a ton, but this year the demand has increased, and fully £20 a ton has been obtained. The demand has been largely stimulated by the spread of the knowledge that arrowroot is quite equal to starch for most kinds of laundry work, while even at present prices it is only half the cost. As its value as starch becomes more widely known, there is little doubt that a market will be developed for a largely increased supply. Taking the figures for last year, we find that 1,284,815 lb. of starch, valued at £17,375, was imported into Queensland, mostly from Victoria, and much of this could no doubt be replaced by the cheaper and equally effective arrowroot for all classes of laundry work, except cold starching—that is, in the case of such articles as shirt fronts or collars. Although its use as a starch is by no means new, the knowledge of it has in the past been limited, and it is only recently that it has come into popular vogue. For years past arrowroot has been utilised chiefly for culinary purposes, such as the manufacture of superior quality biscuits, light cakes, and easily digested foods for invalids.



MARANTA AND CANNA.

The Queensland arrowroot is really the starch product of a bulb of the Canna tribe of plants—namely, *Canna edulis*. This is mentioned particularly because it differs from Bermuda arrowroot, and cannot be sold in Great Britain as arrowroot without some qualifying term attached, such as “Queensland arrowroot” or “Australian arrowroot.” How this has come about is rather interesting. When the Drugs and Food Act was passed by the Imperial Parliament it was specified that arrowroot is the product of the plant *Maranta arundinacea*. That is what Bermuda and Mauritius arrowroots are made from; and manufactured arrowroot from the *Canna edulis* was then practically unknown in Great Britain. How little actual difference there is between the two is indicated by the following analysis, taking the best Bermuda arrowroot (*Maranta arundinacea*) at 2s. 6d. per lb., and the Queensland arrowroot (*Canna edulis*) at 2d. or 3d. per lb. :—

| | Bermuda Arrowroot. | Queensland Arrowroot. |
|-----------------|--------------------|-----------------------|
| Moisture | 13'00 to 16'50 | 17'36 |
| Starch | 82'24 | 81'52 |
| Ash | '124 | '142 |
| Proteids | '052 | '078 |
| Fibre | 4'09 to 1'20 | '90 |

The result is, therefore, chemically about the same, particularly in regard to starch, which is the chief constituent. There is a little more moisture in the Canna, and more fibre in the Maranta. Under the microscope the Canna arrowroot shows a more silky texture, and the grains are slightly coarser.

The *Maranta arundinacea* grows equally well in Queensland with the *Canna edulis*, and arrowroot-growers have at various times cultivated it. It has been known as white arrowroot (from the colour of the bulbs), while the present article is called purple arrowroot. The reason that Maranta has never become popular here is that it yields only half the quantity of arrowroot given by the Canna, and the growers could get no more for the product; and also because the excess of fibre in the Maranta made the matter of treatment more difficult.

METHODS OF CULTIVATION.

A visit to some of the arrowroot farms has just been made to ascertain how the industry is progressing, and how it is being conducted. There is a similarity among them all. The rich alluvial pockets along the banks of creeks are the growing grounds. A manufacturing plant, comprising boiler, engine, pumping, pulping, and straining machinery, is required, which costs about £500. Then there has to be a drying ground, with the requisite frames, and a shed for storage and packing purposes.

The bulbs of the Canna are sown in prepared ground from September to December, when the weather is showery, the rows being 6 ft. apart and 4 ft. between the plants. The usual cultivation follows to keep the ground clear of weeds until the plants get too big. A field of Canna presents a pretty sight, the broad leaves of dark-green giving a fine impression of richness, and sometimes also scarlet flowers are to be seen on the plants. From six to eight months brings the crop to maturity, and a little frost is then beneficial by shrivelling up the tops and concentrating the starch in the bulbs. The tops are cut off by means of a cane knife or bill hook, and the bulbs—something like potatoes, but larger—are then dug as required for milling.

PROCESS OF MANUFACTURE.

The bulbs are carted to the mill and shovelled into a root-washer—a trough 10 ft. or 12 ft. long, through which water is continuously flowing, and in which a spindle revolves and works the bulbs up to the end of the trough. There an elevator receives them and carries them up to the mill. There they are grated in a grinder, or perforated wooden drum, revolving at

Plate I.

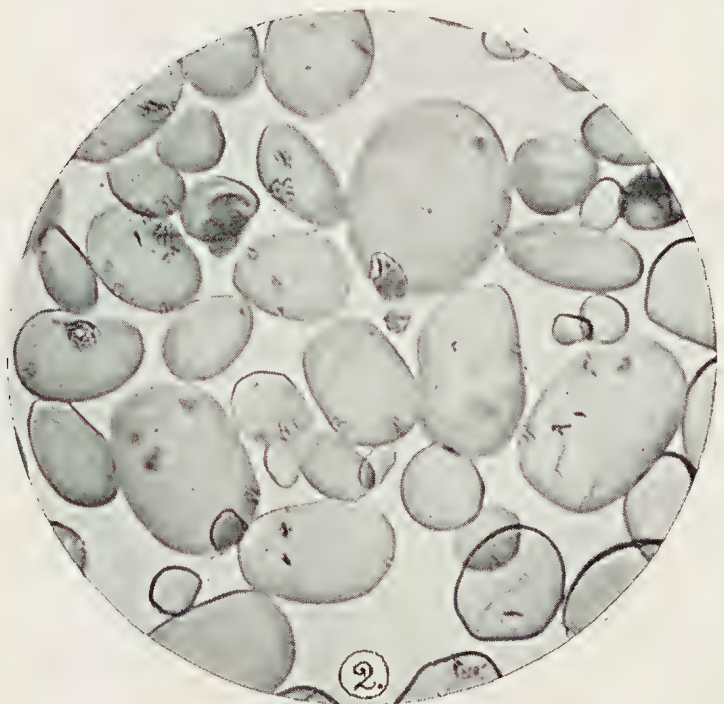
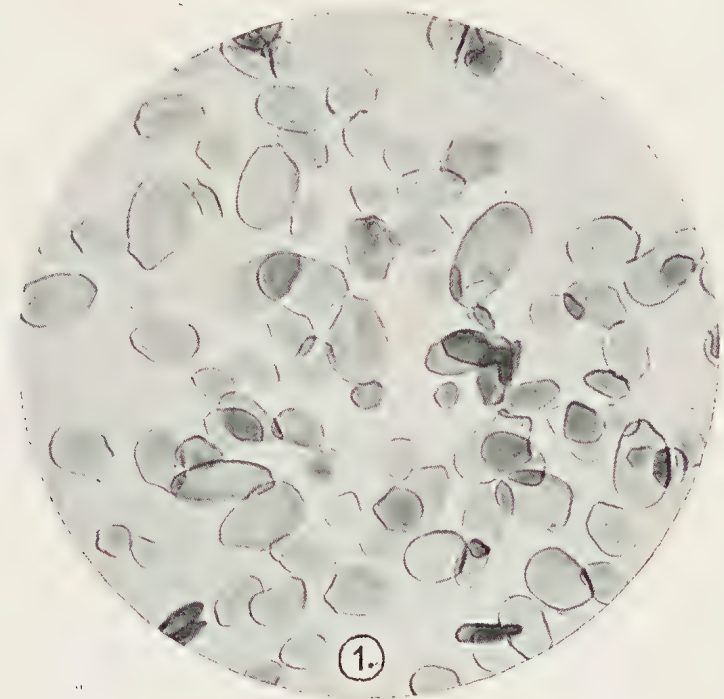

STARCHES MAGNIFIED 250 DIAMETERS.]

1. West India Arrowroot (*Maranta arundinacea*).
2. Tous-les-mois (*Canna edulis*), Queensland Arrowroot.

great speed, and the pulp passed through to a sieve of perforated metal, clean water all the time falling on the pulp. A beater forces the farina and water through the sieve, while the fibre is discharged on to a dump. The farina from the sieve goes into a revolving copper drum, which has also perforated sides, and this takes away some more of the impurities, while the farina goes down into a long trough, through which a stream of water is constantly running. The arrowroot settles at the bottom of the trough, and after some hours of washing is dug out and put into tubs, or other troughs, and more clean water with it. That is repeated three times, the farina during the last having to pass through a sieve of fine muslin. After that the arrowroot is dug out, placed on calico sheets, and put out on frames to dry. The whole process, from the digging of the bulbs to the drying of the prepared arrowroot, occupies about twenty-four hours.

It will easily be seen that it is of little use trying to manufacture arrowroot unless there is a plentiful supply of good clean water. Mr. J. Latimer, who had 8 acres under arrowroot at Yatala this year, was working his mill two or three days a week, and producing about half a ton of arrowroot a day. To do this, he estimated that 24,000 gallons of water were used in eight hours.

The refuse, fibre, and pulp are carted back to the fields for use as manure.

After drying, the arrowroot is ready for bagging, and it is put in sacks lined with calico ready for market. Most of the arrowroot is brought to Brisbane by steamers on account of the cheaper freights. By railway from Stapylton to South Brisbane (24 miles) the freight is 8s. per ton, and 2s. 6d. more has to be paid for cartage to business places in the city—a total of 10s. 6d. per ton if by rail. By steamer from Yatala the freight is 5s. per ton and 1s. 6d. a ton cartage from the wharf to the stores—total, 6s. 6d. By train the cost from Nerang is 12s., and by steamer 8s.; so that the advantage of water carriage will easily be recognised in the case of products which leave only a small margin of profit.

Mr. T. Doherty, one of the principal growers, remarked that arrowroot gave about the same return as corn or potatoes, but it was a surer crop. It would stand flooding that would kill potatoes, and dry weather would not affect it so adversely as it would corn.

At the Melbourne Exhibition, W. Murtha received the gold medal for arrowroot, and J. Latimer the silver medal; and at Earl's Court Exhibition (London), in 1899, Messrs. J. Latimer and Sons received a silver medal and diploma for their exhibit of arrowroot.

EARLY HISTORY OF ARROWROOT.

The name of Mr. Samuel Grimes has long been connected with arrowroot manufacture, and he assisted it along very materially in years past. At the present time, Mr. J. Latimer is probably the grower who has been longest in the business. He related how in 1868 he went to Messrs. R. and G. Board's plantation, Malungmavel, to erect some machinery for the sugar-making, and also to put up an arrowroot manufacturing plant of a primitive type. Messrs. Board had 10 acres under arrowroot, and they then got £40 per ton for it. At that time Mr. Grimes was also growing some. In those days the whole of the product went to Melbourne. As sugar was then paying very well, Messrs. Board relinquished arrowroot-growing, but Messrs. Grimes and Labey continued with it, and soon afterwards some small growers began to raise the bulb. Since then it has continued to be a small farmer's crop, largely on account of labour conditions making it unremunerative to pay much outside the grower's family. The 200 acres grown this year will probably produce 250 tons of marketable arrowroot, worth approximately £5,000. There are areas of suitable land with good water available in the district to widely extend the industry should the demand justify it, and no doubt the day will come when much of the starch used in Australia is manufactured in the same district, from arrowroot, potatoes, maize, and other products which flourish so well there.

MERINO SHEEP AT HERMITAGE STATE FARM.

A report has been received by the Under Secretary for Agriculture and Stock from the manager of the Hermitage State Farm, near Warwick, in which details have been furnished of the amount of wool shorn from the respective classes of stud sheep on the farm at the end of October last.

The young sheep bred on the farm are from pure Glengallan merino ewes, which were presented to the Department by Mr. W. B. Slade, the owner of Glengallan, and are the progeny of rams also bred at Glengallan.

Mr. Slade had the wool of the latter sheep scoured at the Brisbane Technical College, with the resulting weight of 9.93 lb. of absolutely clean wool in a fit state for manufacture.

Stud breeding ewes cut up to 13 lb. of wool at this shearing, and averaged 10 lb. 10 oz. Two-tooth rams, shorn as lambs, cut up to 19½ lb. of wool, and averaged 16 lb.

Two-tooth ewes, shorn as lambs, cut up to 17 lb. of wool, averaging 13 lb. 7 oz. Summer ram and ewe lambs averaged 11 lb. and 9¼ lb. respectively.

SEVENTY-FIVE BUSHEL WHEAT CROP.

According to the agricultural statistics of South Australia, that State is never credited with a very high average yield per acre. It, therefore, comes as a pleasant surprise to hear what the possibilities of wheat-growing in the Southern State are. We learn from the "Farmers' Union Advocate," New Zealand, that last year Mr. T. Pengilly, of Aldinga (South Australia), who makes a hobby of experimenting with various kinds of wheat, had a plot of Federation wheat which gave a return of 75 bushels to the acre. The Department of Agriculture were dubious as to the correctness of the return, but on measuring the ground for themselves they made it a rather smaller area than Mr. Pengilly's measurement, thus proving that the 75-bushel return was within the mark.

DRY FARMING IN NEW SOUTH WALES.

A dairyman and farmer at Narrabri has successfully experimented with the dry farming method, as adopted in some of the Western States of America, and has had the satisfaction of growing some excellent crops of wheat. The attempt was made on black soil, which is generally held to be useless for the raising of cereals. The main point of dry farming is deep ploughing, and an extra amount of working the soil, so that it becomes pulverised and prevents the evaporation of the moisture, which occurs under other conditions. A machine called a packer is also used for pulverising and compressing the sub-soil. These methods were here carried out with the most satisfactory results. After an absence of rain for six weeks, when a knife was plunged into the soil, it was withdrawn with mud sticking to it. It paid the farmer in this case to cut his crop for hay, but had he secured the seed the returns would certainly have been very gratifying.

DARNEL OR DRAKE.

In a letter addressed to a Rockhampton journal (the "Morning Bulletin") by Mr. Geo. Wilkinson, Lion Creek road, Rockhampton, he draws attention to a dangerous grass which has made its appearance in that district—namely, the Darnel (*Lolium temulentum*). He rightly says that this grass "has had an evil reputation from the dawn of history, and the highest authorities are agreed that the tares of Scripture and *Lolium temulentum* are one and the same." He further quotes the Scripture parable of the tares, but he omits to

state that when the servants of the householder asked if they should go and gather the tares (darnel) up, the latter would not allow this to be done until the harvest, "lest, while ye gather up the tares, ye root up the wheat also with them." Why this? It was because the householder knew that the darnel is so widely rooted that it is impossible to eradicate it by hand unless a knife were passed round each plant, otherwise in rooting it up the wheat will also be taken up with it. The Colonial Botanist, Mr. F. M. Bailey, has supplied the following notes on Mr. Wilkinson's letter:—

"The grass referred to by Mr. Wilkinson is one of the best known by farmers the world over, and its bad character has been handed down from father to son, generation to generation, without the matter having been carefully gone into. I have eaten bread made of flour which was made of grain principally composed of drake seed, because, before winnowing machines were much in use, we had to winnow by the wind, and I never heard of anyone being made ill from such food.

"In one of the quotations from Scripture there is nothing said about the grain—the men were not to pull up the tares at that particular time for fear of destroying the wheat. (This sentence can be easily understood by the strong rooting character of the grass.) In other quotations, as to the grass's poisonous properties, it is probable the ergotty rye is answerable for the ill-effects attributed to this tare, Drake or Darnel. I have known the plant in Australia for the past nearly seventy years."

THE VALUE OF LOCAL SHOWS.

At the Agricultural Conference held at Warwick, in June, 1900, a very excellent paper was read by Mr. T. Burgess, of Forest Hill, on "The Functions of Agricultural Societies."

There are those who would belittle the work done in the interests of agriculture and stock-breeding, and sum up their so-called arguments by saying that the only function exercised by the country societies is the holding of an annual show. We do not care to enter into disputation on this opinion, erroneous as we hold it to be. Mr. Burgess, whilst holding that there are too many shows and too much sameness about them ("see one, and you see them all," he said), yet recognised their value to the agricultural community, only asking that they should be rendered more attractive by the introduction of new features into them. Mr. J. Hudson, Rosewood, maintained that those who said that there was not much to be learned from shows, big or little, were not real farmers. If he did not take a prize for a horse he might show, he naturally went to other shows to see where he was wrong. The same thing applied to the cattle and farm produce sections. If a farmer wanted to teach his son anything in connection with agriculture, let him take him round a show, and point out to him the animals and implements which have taken prizes, and indicate the points that are good and those that are bad. The boy would never forget the lesson, and he will have learned something that will be of service to him when he becomes a man. On the value of country shows, Lord Middleton wrote as follows in the "Live Stock Journal" in 1901:—

That the agricultural show system is beneficial, and of value to agriculture in general, is a usually admitted fact, though occasionally I have heard the reverse opinion expressed, with added gloomy forebodings that the heyday of such shows is over.

My own opinion is that agricultural shows are of the greatest value, and at no time more so than the present. It has probably occurred to those who have given the subject unprejudiced attention that the chief value of these competitive exhibitions is threefold—namely, first, the opportunity they give of comparison; secondly, the emulation they excite; third and last (and by no means least), their use as an advertising medium.

We all know the trite old saying that many a man's goose is his swan, and nowhere is this saying brought home to us more vividly than in the show-yard. Frequently have I (and doubtless many of my readers have shared this experience) taken the pick of our farm to the showyard, expecting great things; only to have our pride knocked out of us on entering the ring by finding what we hoped might be the winner of the red rosette relegated to a very inferior place. We have gone home sadder and wiser men, with a teaching, however, which will doubtless show excellent result in the future.

If it were not for these showyard gatherings of stock, I do not see how we should be able to compare our own with that of others, nor arrive at the pitch of perfection now reached. There are men who possess it, but it cannot be counted a universal gift, that power of carrying the definite picture of an animal for any time in the mind's eye; to the "general," therefore, what a boon is the showyard, when he can do his comparing studies within small limits of time and space.

In mentioning the perfection to which stock has attained in the present day, I would call attention particularly to the improvement in the Shire horse. It is extraordinary the stride this breed has made in comparatively few years; the champions of twenty years ago would be regarded as moderate horses to-day. There are other breeds which to me seem to have made similar progress of late years; I might mention the Galloways, the Welsh cattle, the Sussex, and, in sheep, conspicuously the Suffolk. Some may say it is the breed societies which have done this. To a certain extent it may be so; the societies, after all, are the parents of the shows.

Having touched lightly on the privileges afforded to owners of stock by the use of comparison, we now come to the emulation which showyards create; and this must be a valuable constituent of their worth, and stimulate the production of high-class stock. The Briton is at all times fond of competition; in whatever pursuits he may be engaged, he profoundly dislikes being beaten. If it had not been for this enterprising spirit we should not have held the place we do in the world as breeders of pedigree stock; we owe it entirely to our individual patience and perseverance. In France, in Germany, in Russia, and other Continental countries, breeders have to be encouraged by State help. Here it is left to private enterprise, and long may it be so, for it makes us self-reliant and dependent on our own long-practised judgment.

Now we come to the advertising medium of showyards, or the opportunity they afford for publishing, so to speak, the best markets for our goods. It is a well-known fact that the temperate climate of the British Isles fits them for being in a large measure the world's nurseries of pedigree stock. We are subject to none of those variations from which many parts of the globe suffer; no extremes of cold, heat, or drought; and therefore we understand why the outlander, impeded or frustrated by failure on account of these extremes, comes to our shores for reinforcement and renewing of blood.

It is, then, to the centralising depôts of our showyards that the foreigner or colonial makes his way, knowing that there he will meet the best products of the district, county, or country; while in the carefully-prepared catalogue he will find a ready reference to the names and addresses of owners and breeders of the particular breeds he seeks.

In speaking of the advertising value of shows, I must not omit to allude to the great assistance afforded by the Press in its periodical reports of these exhibitions, giving lists and descriptions of the prize-winners, and calling attention to even less fortunate exhibits; these reports are distributed to our daily and weekly papers, and thence go out to the world at large.

So far my remarks have been entirely confined to stock, but the agricultural showyard contains many other desirable exhibits; the implement yards alone would repay considerable expenditure of time and attention.

Whether at the Royal, the Highland, or the larger county shows, the would-be purchaser requiring a plough, a harrow, a binder, or engine finds a

large and varied choice, well suited to all sorts of soils and situations; and the plan followed at certain shows of severely testing some of the machinery, and awarding medals and certificates of merit, affords a safe guide in selecting.

The dairy, the shoeing, the beekeepers' and seedsmen's stands, also the poultry demonstrations, are all of practical importance, and all gathered in so concentrated an area that it is possible at least to run through them within the limits of a day's outing, and the man would have indeed a clouded eye and an obtuse mind who was unable to gather fresh ideas, and take some, at any rate, away with him.

In addition to those named are all the smaller exhibits—small, but none the less important to the agriculturist: fences, troughs, gates, pumps, and lesser tools, such as rakes, forks, spades, &c.; all these can be inspected and studied alike by the small crofter, the 1,000-acre occupier, or the large landed proprietor.

Some people cavil at the number of small shows in certain country districts. I myself have been disposed to question whether the number was not excessive, as they seem at times to overlap one another; but, doubtless, this is an ill which rights itself, for those that do not pay will disappear. Our larger shows monopolise so much time and expenditure that it is not everyone who can afford to patronise them, extending as they do from two to eight days. Now, at the little one-day local show the small farmer can start in the morning from home, take his prize, and be back again with his animal the same evening; he is not scared here by what is termed the professional exhibitor, but can meet his like on fair grounds. It brings to the front many a small breeder, and many a good animal, who, in their turn finding their ways thither, act as feeders to the larger shows. Much responsibility, however, rests with the promoters and councils of these local shows in initiating classes and providing adequate prizes for bringing out their district breeds to the best advantage; much lies with them in encouraging the right sort of stock, suited to the requirements of the day, for no doubt we agriculturists must travel with the times. The services of the best judges should be carefully secured, well-known men of practised judgment, who can be depended upon to recognise and pick out the correct stamp. Through these means the local shows will, as I suggested above, act as feeders to the larger ones, and the whole work together in framing our national show system. There is one most important item of agricultural exhibitions which I have left to the last—that is, the thorough inspection of animals by the veterinary surgeons; for if we are to be, as it were, the Stud Farm of the World, it is all-important that one of our first considerations in breeding stock should be the freedom of that stock from hereditary disease. Almost yearly new countries are opened out, our colonies are brought closer to us, the means of communication advances by strides, there will be larger areas for civilisation and cultivation; and, consequently, pure-bred stock will ever be in greater demand. Thus it behoves us to keep up a plentiful supply of the right material, and to encourage and perfect to its fullest scope that show system which plays so important a part in its development.

WHEATS AT THE STATE FARM, ROMA.

Up till quite recently the quality of grain rather than yield per acre has been characteristic of the Maranoa district, and it is only of recent date, season 1906, that rust has proved, at certain times, a serious menace to the industry. The usual seasons are marked by a dry bracing atmosphere, and a rainfall aggregating 20'30 in. per annum.

It is only a natural consequence that prolific, hardy wheats would be most in favour, and rust-resisting varieties not of much moment.

At the Roma State farm special attention is being given to the evolution of new varieties of wheat by cross fertilisation and the carrying on of varied systems of cultivation, to which the "Campbell" dry-farming system has been added.

Comparative tests of a number of new wheats from England, America, and the Southern States are being made. Some of the returns this year are above normal, up to 37.6 bushels per acre being harvested from small plots grown under field conditions, and the district average promises to be much better than usual.

To make the results of experiment work as widespread as possible, and to give farmers a chance of working up into a more reliable rust-resisting, strong-flour wheat, single bushel lots of seed of Bungie No. 1 were sent out in time for the wheat-planting season of 1908 gratis, with freight paid, to certain farmers throughout the wheat belt, with a proviso that defined rational methods of cultivation should be followed. A preliminary inspection of many of the farmers' plots served to show that the variety is likely to do well under favourable conditions. So far, the only return to hand is from Mr. White, of Blythdale, who harvested 40 bushels from 1 bushel of seed sown on $1\frac{1}{2}$ acre. A field plot of 5 acres near the State farm has given 35 bags from 5 acres. At the State farm a 4-acre plot gave 26.7 bushels per acre. The variety came out of the rusty year of 1906, with a yield of 17.5 bushels per acre; and in the dry season of 1907, when only 3.75 in. of rain were recorded from seeding time to maturity, it gave a return of $14\frac{1}{2}$ bushels. The illustration in the present issue will convey an idea as to what perfection the crop reached this year on a light sandy soil with seed sown on 22nd June. A late sowing on 5th August, as a catch crop, gave a return of 20 bushels to the acre. Eight weeks after appearing above ground the wheat was well out in ear; but this, of course, is an exceptional circumstance.

The variety has so far proved itself superior to many others now universally grown, and has shown out conspicuously above a large number of other cross-bred wheats. It is a quick-maturing, rust-resistant, and rust-escaping kind, is a light stooler, and has a slender, tough straw, with a minimum of flag, and is a good wheat to strip. Numerous inquiries have been made for seed for next season's sowing, and many farmers have expressed their intention of seeding down increased areas.

SILAGE AT HERMITAGE AND ROMA STATE FARMS.

Hermitage.—The accompanying illustrations, taken whilst the farm apprentices were at work filling the silo at the latter end of last summer, to provide winter feed for stock, serve to demonstrate the process of cutting, carting, chaffing, and elevation of fodder. An ordinary chaff-cutter has been adopted, and will cut 4 tons an hour if fed to that capacity.

For economic handling of bulky crops, nothing surpasses the corn-binder for tying up conveniently-sized bundles, and facilitating subsequent handling. Lucerne, sorghum, Kafir corn, maize, and massagua, aggregating over 150 tons, were turned into silage last year, and the manager asserts that in the "fibro-cement" silo, after removal of upper crust (which always decays), the subsequent waste did not exceed 1 per cent.

The building is of 120 tons' capacity, octagonal in shape, with hardwood timber frame lined with fibro-cement sheets; this material does not show any signs of deterioration from silage acids, after two seasons' use. Exception may be taken to its thinness ($\frac{3}{16}$ of an in.), but the makers are adopting a stouter gauge; and, should a cheap and suitable form of re-inforcement be found, its value for lining will be enhanced.

Stock of all descriptions thrive on the silage, and were fed throughout the winter. Even up to early December, use has been found for feeding two

Plate II.

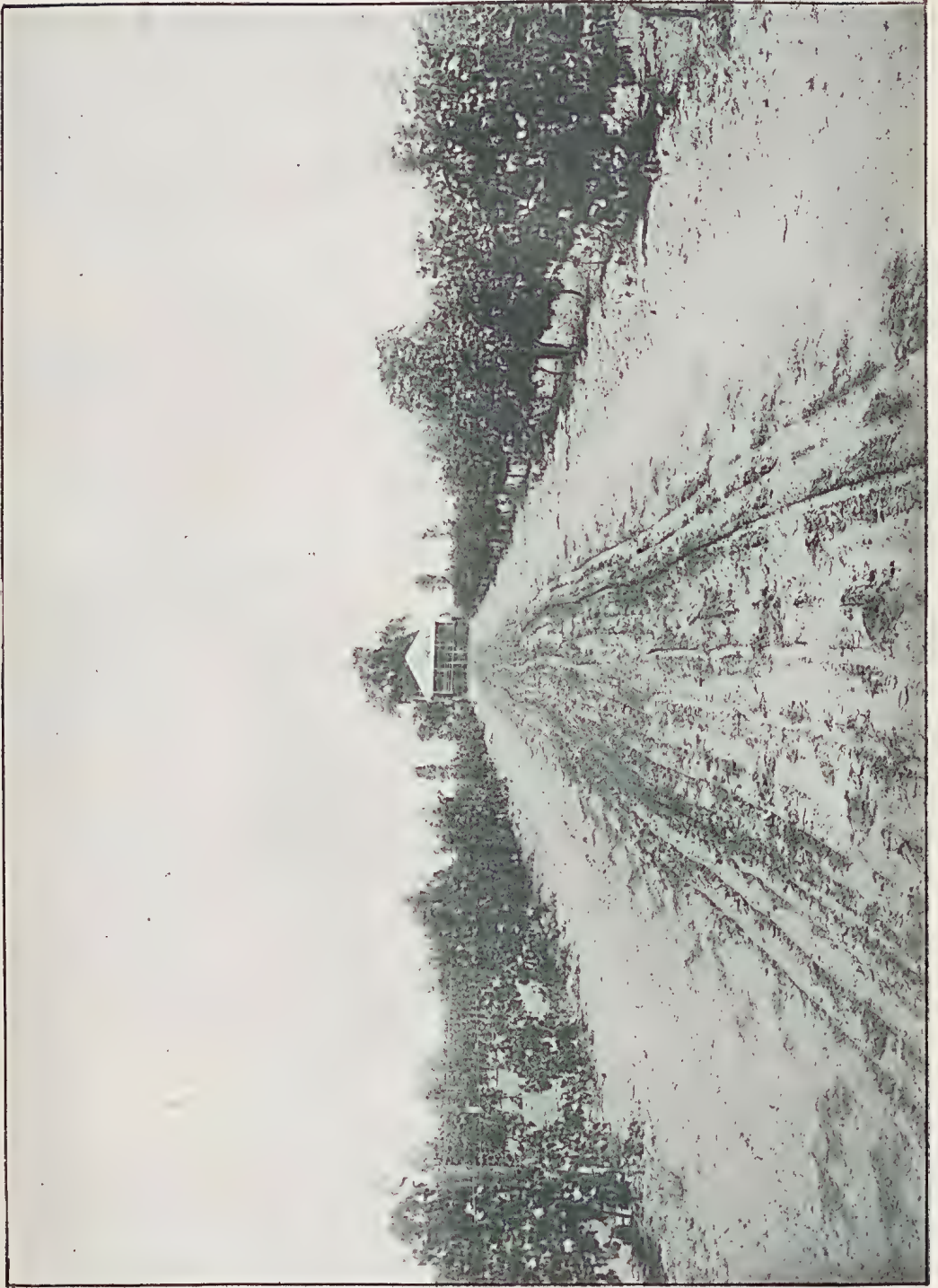

THE MANAGER'S RESIDENCE, STATE FARM, ROMA.

Plate III.



BUNGIE NO. 1 WHEAT AT THE STATE FARM, ROMA.



Plate IV.



“ALPHA” WHEAT AT THE STATE FARM, ROMA.

Plate V.



ROMA STATE FARM.—STRIPPER AT WORK ON "PRATT'S COMEBACK."

Plate VI.



HERMITAGE STATE FARM.
1. Apprentices' Quarters.
2. Corn Binder at Work on a Crop of Kafr Corn.
3. Carting Kafr Corn to the Silo.



Plate VII.

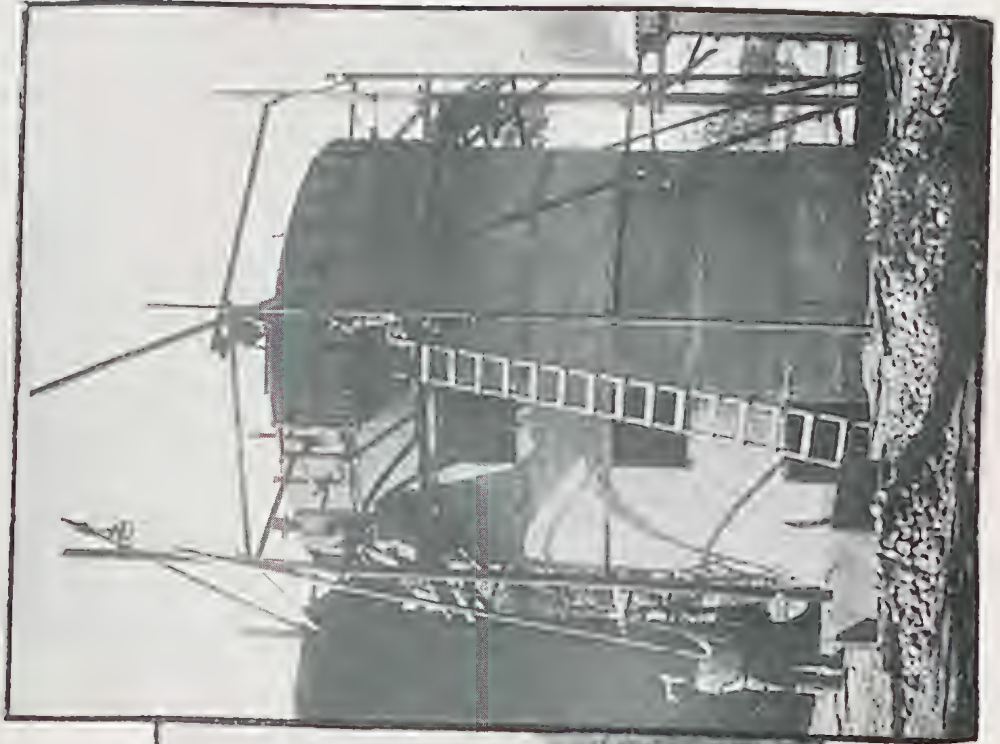

RE-INFORCED CONCRETE SILO IN COURSE OF CONSTRUCTION AT THE STATE FARM, ROMA.



RE-INFORCED CONCRETE SILO (120-TON) AT THE HERMITAGE STATE FARM.

stud merino ewes confined to small paddocks for the lambing. Some 20 odd tons still remain in the silo, and it is proposed to refill it in the near future.

Roma.—The latest type of re-inforced concrete silo (100 tons capacity) is shown in course of erection. The permanency and non-corrosive character of this class of building will be sufficient to justify its popularity.

The wall is 5 in. in thickness, except for a height of 3 ft. from the foundation, which has a thickness of 9 in. The sets of moulds in position at the top of the wall are secured by means of two bolts to each pair of moulds, and rest on the last completed course. Johnson's steel wire lattice, which may be distinguished in position, is made in 3 ft. 6 in. width, and long enough to go round the whole circle, and give a small lap; the 6 in. projecting at top serves to fasten the next roll of lattice to. The diameter of this silo is 18 ft. Gauges are used to keep the wire $1\frac{1}{2}$ in. from the outside wall whilst the process of filling and tamping goes on.

Work was completed on 8th December, and crops for filling are well forward.

NATIONAL AGRICULTURAL AND INDUSTRIAL ASSOCIATION OF QUEENSLAND.

The following letter has been addressed to the various Agricultural Societies throughout the State, by the council of the above association. The proposal appears to us to be one which should commend itself to the earnest consideration of Agricultural and Pastoral Societies:—

“At the last monthly meeting of the council of the National Agricultural and Industrial Association, it was brought under notice that certain applications from country societies had from time to time come in, having regard to affiliation and to the settlement of various minor show matters of detail with which it is very desirable that all societies in Queensland should be in full accord. It was thought that if all—or, at any rate, a large number—of the agricultural societies of the State joined one chamber for mutual protection and co-operation, it would prove a satisfactory step. We are, therefore, desirous to place before you the following information:—

Name: “Chamber of Queensland Agricultural Societies.”

The following matters would be dealt with—

1. Arranging show dates.
2. Registration of judges.
3. Endorsement of disqualifications.
4. Uniformity in schedules, awards, ribbons, &c.
5. Regulations governing milking competitions.
6. Examination of stallions.
7. Compilation and publication of prize schedule and catalogue.
8. Method of keeping accounts, &c., &c.

An affiliation fee of £1 ls. per annum to cover necessary outlay would be required, and no doubt arrangements could be made that the secretary of the National Agricultural and Industrial Association of Queensland would act in a similar capacity if so desired. Meetings could be held at the National Association's rooms.

Provided sufficient societies are favourable to this scheme, a meeting will be called at a suitable date in Brisbane to formulate and establish the same.

I shall be glad to hear without delay from your society regarding their intention to join in this new movement.

It is suggested that the Department of Agriculture should nominate a representative also to sit with this chamber.

(Signed)

JOHN MACDONALD, Chairman.
C. A. ARVIER, Secretary.

Dairying.

THE DAIRY HERD, QUEENSLAND AGRICULTURAL COLLEGE
GATTON.

RECORD OF COWS FOR MONTH OF NOVEMBER, 1908.

| Number. | Cow's Name. | Breed. | Date of Calving. | Total Milk. | Average Test, Per cent. | Commercial Butter. | Remarks. |
|---------|-------------------|--------------------|------------------|-------------|-------------------------|--------------------|------------|
| | | | | Lb. | | Lb. | |
| 1 | Peewee ... | Holstein-Sh'rth'm | 20 May, 1908 | 763 | 4.2 | 35.09 | |
| 2 | Whitefoot... | Holstein-Devon | 20 Oct. " | 984 | 3.0 | 32.04 | |
| 3 | Cuckoo ... | Jersey ... | 4 May " | 387 | 7.0 | 31.68 | |
| 4 | Orange ... | Guernsey ... | 22 Oct. " | 721 | 3.8 | 30.52 | |
| 5 | Lily ... | Ayrshire ... | 2 May " | 492 | 5.1 | 28.34 | |
| 6 | No. 1 ... | Shorthorn ... | 1 Nov. " | 884 | 3.0 | 27.79 | |
| 7 | Burton's
Fancy | " | 7 Sept. " | 496 | 5.1 | 27.63 | First calf |
| 8 | Daisy ... | Holstein ... | 24 Oct. " | 939 | 2.6 | 27.23 | |
| 9 | Cuckoo ... | Jersey ... | 4 Mar. " | 606 | 4.0 | 27.08 | |
| 10 | Len ... | Ayrshire ... | 22 Sept. " | 661 | 3.6 | 26.44 | |
| 11 | Carrie ... | Jersey ... | 16 Jan. " | 525 | 4.4 | 25.92 | |
| 12 | Sue ... | Grade Holstein ... | 25 May " | 611 | 3.8 | 25.87 | |
| 13 | Lady Loch | Ayrshire... | 24 June " | 522 | 4.4 | 25.77 | First calf |
| 14 | Hettie ... | Ayrshire-Sh'rth'n | 20 Mar. " | 448 | 5.0 | 25.28 | |
| 15 | Eve ... | Jersey ... | 16 Oct. " | 649 | 3.5 | 25.18 | |
| 16 | Ethel ... | Grade Shorthorn | 3 Sept. " | 667 | 3.4 | 25.09 | |
| 17 | Lubra ... | " Holstein... | 5 June " | 530 | 4.2 | 24.93 | First calf |
| 18 | Cocoa ... | Jersey ... | 10 Nov., 1907 | 508 | 4.2 | 24.89 | |
| 19 | Dewdrop ... | Holstein ... | 10 Nov. " | 746 | 3.0 | 24.55 | |
| 20 | Grace ... | Shorthorn ... | 30 May, 1908 | 591 | 3.7 | 24.32 | |
| 21 | Lalla ... | Grade Holstein... | 28 July " | 525 | 4.1 | 24.07 | First calf |
| 22 | Winnie ... | Shorthorn ... | 8 April " | 560 | 3.8 | 23.71 | |
| 23 | Night ... | Grade Holstein ... | 5 Oct. " | 720 | 3.0 | 23.07 | |
| 24 | Remit ... | " | 6 Aug. " | 673 | 2.7 | 23.59 | |
| 25 | Lark ... | Ayrshire ... | 6 June " | 546 | 3.8 | 23.11 | First calf |
| 26 | Dot ... | Shorthorn ... | 12 Nov. " | 471 | 4.2 | 22.12 | |
| 27 | Rhoda ... | Grade Holstein ... | 28 Mar. " | 570 | 3.5 | 22.12 | |
| 28 | Nettle ... | Shorthorn ... | 14 May " | 603 | 3.3 | 21.98 | |
| 29 | Mona ... | Grade Holstein... | 20 Oct., 1907 | 509 | 3.8 | 21.55 | |
| 30 | Nancy ... | " Guernsey | 7 May, 1908 | 565 | 3.4 | 21.25 | First calf |
| 31 | Lucy II. ... | " | 1 May " | 368 | 5.0 | 20.54 | |
| 32 | No. 6 ... | Shorthorn ... | 27 Oct. " | 666 | 2.6 | 19.31 | |
| 33 | Madge ... | Grade Holstein ... | 16 June " | 433 | 3.9 | 18.84 | First calf |
| 34 | Chocolate ... | Shorthorn ... | 5 May, 1907 | 400 | 4.8 | 18.35 | |
| 35 | Maggie ... | Grade Holstein... | 6 May, 1908 | 328 | 4.8 | 18.28 | |

Pastured on natural grasses only.

THE HEREFORD COW AS A DAIRY BREED.

In answer to articles appearing in several papers recommending dairymen to develop the milking propensities of Herefords and make of them a dairy cow, will you allow me to give on the matter the views of "A Young Dairyman."

The latest news from London informs us that a Hereford cow won the milking and butter contest in that city. Is this sufficient to warrant dairymen going in for Hereford cattle as milkers?

What is the Hereford breed? Purely a beef breed. Let us admit for an instant that some strains of that breed have been so developed as to be fair milkers. We might class such animals as of the dual purpose class, of which the red poley is the best type:

What is a dual purpose cow? It is a cow that will produce a fair amount of milk and whose calf will fatten readily.

Is such a cow a profitable dairyman's cow? In my opinion the dual purpose cow is a rank failure from a dairyman's point of view.

What is a steer when weaned worth to a dairyman? At the prices now ranging in Queensland, we may put it down at 30s. at the outside, and that for a very good steer.

Now, suppose we have fed pigs with the milk given to the calf during those six months, would we not have realised as much?

The partisans of the dual purpose cow say that their bull calves raised into steers realise more than Jersey steers.

If that is their only argument against the Jersey, it will not hold water, because—First, I consider that the raising of steers is a mistake on a dairy farm; second, because a cow of the dairy breed will produce several pounds more of butter a year than a cow of the dual purpose breeds.

Thus we have:—

| DUAL PURPOSE COW. | | DAIRY COW. | |
|--|---|--|---|
| Profit. | Loss. | Profit. | Loss. |
| A few shillings for a better class of steers | A few pounds for a smaller cream cheque | Greater quantity, and consequently more money for cream
A better class of heifers | None

Since the steers are killed and the skim milch turned into pigs |

I am a dairyman and a breeder of milking Shorthorns—not because they are a dual purpose cow, for I do not consider them so, but simply because they yield a large amount of milk on a fair test. And I say this—all dairy breeds are equally good for a dairyman, provided he sticks to one, and does not mix them at random. Goodness knows, there are enough dairy breeds to pick from without going in for Herefords. Supposing a dairyman wanted to build up a herd of milking Herefords. He would be starting forty years behind the times. The best he could select as a foundation would only be fair milkers. Let us admit for a moment that he was lucky in securing a sire from a good milker; where would he secure such another, and where would he secure such another again?

There would have to be several working the same problem out to be successful, or else one would run the risk of introducing a sire inferior to one's improved cows, thus deteriorating the herd. Then there would be that inexorable law of Nature—"atavism" in a most marked degree, and the one fair cow would have heifers of a more beefy type. And after forty years of careful breeding one would not then be up to the standard of the fair dairy cow now obtainable in dairy strains.

Then his sons would follow in their father's footsteps:—1. If so, what a trouble to select an ever better class of sires without in-and-in-breeding. 2. If not, then why spend money on improving the Hereford cow, to be at most a dual purpose cow?

It is all right for the breeder who has money to spend, and takes it up purely as a hobby; nay, it is pardonable in a beef breeder to keep the milking qualities of his cows for the supply of the young, but it is foolish if he be a dairyman.

Would it not be a hundred times better to start with a dairy type, possessing good milking qualities, where the law of atavism would not be continually checking one's progress, and where the procuring of improved sires would be an easy matter?

The Hereford, as it is now, is a very hardy beast, but so are the Ayrshire and the Kerry, aye, the Jersey itself (except perhaps in the rearing of the young). But, improve the milking propensities of Herefords, and they will go down in health like all others. Once the strain is applied, the health breaks down.

A STORY OF TWO COWS.

At the Illinois Agricultural Experiment Station are two cows, the story of whose work is well worth telling. They were brought up alike on a farm near Elgin, Ill., and obtained their early education in the same herd of 100 cows. Here at the University, with the very same surroundings and equal opportunities, they have drifted far apart in character, and their progress has been in opposite directions. It is not a difference of hide, or horns, or temper; it is not that one is wild and the other a pet. It is not a difference of beauty or intelligence, but solely a difference in the way they have worked, a difference in the money they have earned for the owner.

All the milk of these cows has been weighed and tested for years. A record has been kept of every pound of feed consumed by each animal both summer and winter. Each year Gold produced on the average 11,390 lb. of milk containing 405 lb. of butter-fat, but during the same time Gilt averaged only 3,830 lb. of milk with 138 lb. of butter-fat. These cows were both cared for in the same way; they were given the same kinds of feed, and allowed to eat all they wanted. Gold ate one-half more than Gilt, but produced nearly three times as much milk.

Equal amounts of feed made in the one case 188 lb. of butter-fat, and in the other 100 lb. The one cow produced nearly twice as much as the other from exactly the same feed in kind and amount.

Counting the butter-fat at 23 cents per lb., and taking out the exact cost of feed in each cow, the one cow brought in a profit of £6 18s., while the other lacked £1 2s. of paying her board at market prices of feed each year.

This comparison, exact and complete for three years, and including the record of both milk and feed, means a great deal more than a single year's comparison or one in which it is necessary to introduce an estimate.

It would be very gratifying, indeed, if it could be truthfully said that these two records are extreme and exceptional, therefore do not stand for any general condition of the dairy business in Illinois. But the very opposite is true. These two cows represent a large part of the dairy cattle of the State.—
“Live Stock World.”

EXPORT OF BUTTER.

The quantity of butter graded for export by the Department of Agriculture and Stock from 1st August, 1907, to 29th August, 1908, was as follow:—

| 1907. | Boxes. | 1908. | Boxes. |
|----------------|--------|--------------|--------|
| August ... | 6,654 | January ... | 35,190 |
| September ... | 7,135 | February ... | 31,370 |
| October ... | 11,177 | March ... | 32,645 |
| November ... | 9,039 | April ... | 28,615 |
| December... .. | 18,064 | May ... | 22,796 |
| | | June ... | 10,189 |
| | | July ... | 5,231 |
| | | August ... | 6,405 |

The lesser quantity graded during the latter three months is accounted for by the shortage of supplies in Victoria, which was made good by shipments from Queensland. The total shipments for the twelve months amounted to 224,510 boxes, equal to 11,225,500 lb., or 100,227 cwt. 2 qr. 10 lb.

Poultry.

OSTRICH NOTES.

In an article on "Some Ostrich Food Plants," in the "Transvaal Agricultural Journal," by Joseph Burrtt-Davy, F.L.S., Government Agrostologist and Botanist, some very valuable and interesting information is given on this subject.

As in Africa, so in Queensland, there is sometimes a scarcity of natural grasses during a dry summer, and it becomes necessary to provide green food at such season. This is furnished, says Mr. Burrtt-Davy, by irrigated lucerne, an acre carrying five and even seven birds under favourable conditions. Maize and chopped leaves of the American aloe can be added for the sake of variety, to furnish a more evenly "balanced" ration, and to act as a corrective to the succulence of the green lucerne. The latter, he says, is the king of ostrich foods. A rumour had rached the Transvaal that lucerne produces a poor quality of feather. When, however, he made careful inquiry amongst breeders, he found that the rumour was based on insufficient data. It seems that there is a greater mortality among young chicks if fed *exclusively* on lucerne than when they have some natural veld (native grasses) in addition. With the enormous increase in the number of birds kept on the wild Karroo veld, there is a consequent tendency to over-production of common feathers, and this is likely to increase. Under such circumstances, only high-grade qualities will command good prices, and, to produce these, particular attention must be paid to the feeding of the birds. Variety of diet is found to be as necessary for the successful raising of ostriches as for poultry, cattle, horses, and other kinds of live stock.

With respect to the American aloe (*Agave americana*) as an ostrich food, the writer says that it is found useful in seasons of drought. It cannot be pastured by the birds, but must be chopped up for them. Two men can cut up enough for 100 birds in two hours. This agave is more nutritious than the prickly pear (*Opuntia ficus-indica*), also used as ostrich food, and it can be used without the addition of maize; but it contains an astringent juice, and, if fed alone, proves too constipating; a mixture of prickly pear, or other succulent feed, acts as a corrective to this tendency; 25 lb. per diem per bird is considered a suitable ration. Amongst other suitable foods for ostriches are mentioned green oats and barley, winter wheat, rye, rape, maize, and Australian saltbush. The native species of the latter (*Atriplex capensis*) is readily eaten by ostriches, and the Australian species, of which seed can be had more easily, is equally palatable. Maize is largely used for ostrich feeding, and the ostrich farmers on the Transvaal high veld think it pays them better to buy their grain than to grow it. One farmer stated that his annual maize bill came to £400.

OSTRICHES AS ORCHARD SCAVENGERS.

A fruitgrower near Grahamstown, who has 150 acres in fruit trees, uses ostriches as scavengers, turning them into the orchard for about an hour each day. During the fruit season they pick up the fallen and damaged fruit, thus preventing it from becoming a breeding place for insects. At other times of the year they keep down the weeds and also manure the ground. They did no damage to the fruit on the trees, but this was, perhaps, because, being left only for a short time each afternoon, they had not time to do more than gather up what lay on the ground.

IMPORTANCE OF SELECTION OF BIRDS.

There is great variation in the class of feather produced by different birds. The best of feeding and the most favourable climate will not produce high-class feathers from birds of poor quality. The power of producing good feathers seems clearly to be an inherited character. The high standard of feathers attained at the present day is due to steady and skilful selection during some 30 years and the mating together only of wisely selected birds. Perhaps in no industry is the value of selection more clearly demonstrated than with ostrich farming, although it is, perhaps, the youngest of stock industries. Common birds can be bought to-day at £1 per head; but selected, pedigree birds readily change hands at £250 a-piece; whilst Mr. Davy was in the Albany district one choice bird brought £400, and a record figure of £1,000 a pair has been obtained by Mr. White, of Table Farm. Grandchildren of Old Jack of Halesowen, who is perhaps the most famous bird in South Africa, sold last year at £10 a-piece while still young chicks.

AGE OF DOMESTIC OSTRICHES.

A profitable feature of ostrich farming is the age to which ostriches live, and continue to produce good feathers, when in captivity. Old Jack of Halesowen has been in the possession of Mr. Hilton Barber for 32 years, and how much older he may be is not known. He is probably one of several caught by Mr. Heathcote in Khama's County, whence that gentleman's original stock came. Old Jack cost Mr. Barber £40, and is claimed to have earned no less than £32,000 for his present owner.

PRICES FOR FEATHERS.

Prices at the last Port Elizabeth show were at the rate of £79 per lb. for prime white feathers. A good bird ready for plucking will average from £6 to £10 per bird per year. Mr. Gilfellan's young birds averaged £5 the last plucking. Plucking begins at the age of nine to ten months, when the first payable returns realise from £3 to £4 per bird.

OLD HENS FOR THE TABLE.

When hens have reached the age of between two and a-half to three years of age it is high time to get rid of them and supply their places with younger birds. What is to be done with them? The accepted opinion is that they are too tough for the table. If, however, they are properly killed and cooked they are perfectly eatable. In the first place, before being killed they should be kept without food for a day and a-half, when they will keep for a long time in cool weather. When drawing them, instead of making a large cut and inserting the whole hand to withdraw the intestines, the plan recommended in an English poultry journal is as follows:—

Lay the fowl breast downwards, pick up the skin on the back of the neck, slip the point of the knife through, and cut towards the head so as to leave a piece of skin about 3 inches long. Fold this back until the neck is bare close up to the body. There is a spot which shows whiter than the red of the neck. Nick on both sides, and the joint will easily break. Put the knife underneath the neck and scrape toward the head, and cut off the skin at the same length as the other, thus leaving two folds to cover the broken joint, so as to hide the red and make the front of the dressed fowl more presentable. Set the bird on its stern, take the crop in the forefingers of the right hand, and work the outer skin away from it all round. A finger inserted into the front cavity will work the crop quite clear, and it can then be drawn out. Now take the fowl so that its back lies balanced in the left hand. Insert the middle finger of the right

hand, and pass it tightly round so as to break all adhesions and thoroughly loosen all internals from the breast. Turn the fowl over in the hand. The lungs lie in cavities on either side of the backbone near the base of the wings. These may be loosened by inserting the end of the finger in the cavities and levering them out. Push the finger in as far as possible, make a hook of the end joint, and draw back, pressing close upon the backbone so as to break all attachments.

Now set the bird on its neck end, press the thighs well forward until the feet are at the neck end. Take hold of the rectum with the thumb and forefinger of the left hand, and lift so as to almost take the weight of the bird. Make a slight incision, keeping the edge of the knife up, well toward the tail. Insert a finger and press down tightly along the backbone, so as to detach the large intestine. Then curve the finger, and loop up the tail. Now the point of the knife may be placed under it and the rectum cut clean out. This is a neat and perfectly clean way. As the fowl now lies on its back the gizzard is on the right side. Work a finger round the gizzard and loosen what is called the apron fat. Then if the two thumbs are brought to the front of the gizzard (whilst the hands surround the body) it can be forced out through the small orifice. If the bird is held with one hand and the gizzard steadily pulled with the other, all the intestines, heart, liver, and lungs will come out clean, providing the loosening at front has been properly done, without putting the hand in the bird or making a large, unsightly hole. These fowls should be boiled slowly for 2 hours the day before they are to be served, then allowed to cool in the water, and the next day put on and boiled slowly for 1½ hour. These will be so tender that the flesh will slip off the bones if one is not careful in carving. Another way is to put them in a steamer for three hours, and roast them the next day.

An old hen may be made quite tender by boiling it for three or four hours with a couple of good-sized pawpaw leaves.

HIGH PRICES FOR OSTRICHES.

Mr. Owen Collett, of Lansdown, Trafalberg, has just sold his well-known pair of ostriches, Ruby and Molly, to Mr. Arthur Forbes, for the sum of £1,000. The stock of this pair of birds is much sought after, and realises high prices. We have to report (says "Midland News") yet another big deal in breeding birds and chicks. Mr. Barrett, of Montagu, Fish River, has just sold two pairs of breeding birds at £300 per pair, twenty-nine months old chicks at £17 10s., and also a number of five months birds at £10.

What better encouragement could be needed to induce those who can afford to import good ostriches to follow the example of Mr. T. Behan, of Garfield, near Jericho, on the Central Railway line, who imported a pair of birds from South Australia, and has been eminently successful in raising chicks and marketing feathers?

STATE POULTRY FARMS IN NEW ZEALAND.

"New Zealand Town and Country Life" says:—"A statement of the expenditure and receipts in connection with the State poultry farms shows that these institutions are being run at a considerable monetary loss. The following are the particulars, the larger amount in each case representing the expenditure and the smaller amount the receipts:—Ruakura, £651 and £405; Moumahaki, £624 and £428; Burnham, £742 and £452; Milton, £1,259 and £498. The total expenditure was £3,276, and the total receipts £1,784."

The Orchard.

PINEAPPLE-GROWING IN FLORIDA.

By H. HAROLD HUME.

The Florida pineapple industry is now not more than forty or fifty years old. Indeed, considered from a commercial standpoint, it has scarcely more than attained its majority; yet the crop annually produced in Florida is considerably more than half a million crates.

From the most reliable information we have at hand, the first pineapples produced in Florida were grown by Mr. Benjamin Baker, Key West, Florida, from slips obtained in Havana, Cuba, and set on Plantation Key about 1860. By 1870 numerous other small plantings had been made on the neighbouring keys, and by 1876 the plants were so well distributed along the East Coast of Florida that the settlers began to take an interest in them as a commercial crop. In 1879 the first fruit was shipped by Mr. James H. White, Malabar, Florida.

Pineapple culture on a large scale, however, had its origin in the plantings of the late Captain Thomas E. Richards, Eden, Florida. In the summer of 1880 he set 28,000 slips on the beach side of the Indian River. The bears destroyed the first crop produced, and the whole planting was transferred to the mainland. About 1884 the first fruit was shipped. To-day one may stand on any elevated position at Jensen, Eden, Eldred, or elsewhere on the East Coast of Florida and look out for miles over solid fields of pineapples, no other cultivated crop in sight, and during the shipping season the fruit is forwarded by trainloads.

The red Spanish pineapple constitutes about 98 per cent. of the total plantings, Abbachi, Smooth Cayenne, and Porto Rico make up the remainder.

AVAILABLE LAND AND CHARACTER OF THE SOIL.

Pineapples are now grown on a commercial scale in Florida, on a narrow strip of land lying between the Indian River on the East and the Savannah or damp prairies on the West. This ridge varies in width from a $\frac{1}{4}$ -mile to about $1\frac{1}{2}$ mile, and extends, with numerous breaks of low, moist land, from some distance north of Port Pierce to Miami, Florida, a distance of about 125 miles.

Judged by common standards and for ordinary crops, the soil composing lands shows this ridge would be considered very poor. The early surveyors described it in their notes as not being worth the annual taxes levied in those early days. The chemical analysis of the best lands shows the following composition:—Silica, 97.35 per cent.; lime, .086 per cent.; magnesia, .051 per cent.; potash, .011 per cent.; iron and alumina, .510 per cent.; phosphoric acid, .043 per cent.; nitrogen, .07 per cent.; humus, 1.13 per cent., and traces of other substances. By analysis of many other lands, sand was shown to constitute over 99.32 per cent. of the total composition. From this it will be seen that the amount of essential plant food is a negligible quantity, and without fertilisers the crops could not be produced. The culture of pineapples on these lands is one of the most striking results of the use of commercial fertilisers.

By physical analysis these soils are shown to contain very little fine sand, silt, or clay. They are mostly coarse, and their water-holding capacity is therefore very poor. This is a matter of no small importance, as the pineapple



APRICOTS, GROWN BY MR. H. SLAUGHTER, AT SOUTH BRISBANE.

plant cannot be successfully cultivated in Florida, or, in fact, elsewhere on water-charged soils. In regions of excessive rainfall soils of coarse texture are best.

PLANTING.

During the rainy season, July, August, and early September, is the planting season favoured by all planters, preference being given to the month of August, provided slips of sufficient size can then be obtained. Planted during the above period they make considerable growth, and become well established before the winter dormant season sets in.

Nearly all fields are set with "slips" produced from buds on the stem just at the base of the fruit. Some "suckers" produced from buds on the lower leafy stem are also used. Slips fruit in about twenty or twenty-two months after planting, and bear 90 per cent. and over of a crop. Sucker-set fields bear their first crop in about twelve months from planting, but the crop is very irregular and extends over a long period.

The plants are set 20 by 20 in., or 20 by 24 in., about 12,000 being put on an acre. The number varies with the number of alleys or pathways left through the field. The field is carefully marked off, and the planting is done with a dibble. Before planting a few of the basal leaves are commonly stripped off, and the plants are set moderately deep to prevent their toppling over. Soon after planting a small amount of cotton-seed meal should be dropped into the bud of each plant to prevent "sanding"—*i.e.*, becoming blown full of sand. Plants with sand-filled buds have a hard struggle to live, and frequently they must be taken up, the sand shaken out, and reset.

MARKETING.

The bulk of the Florida crop is not allowed to reach full maturity before picking. Just before coming to full maturity the fruit is dark black green in colour, with angular, pointed eyes. The fruit is picked in the following stage, when the eyes flatten down in the centre, become elevated at the angles, and change to a pale green colour.

It is gathered by breaking it from the plants. Two men usually work together; one gathers the fruit and tosses it to his helper in the pathway, who catches it and places it in his basket or other receptacle. The fruit is wrapped in paper, then packed in crates holding about one half-barrel. The fruit is sized by the eye as it is packed; the sizes commonly used are 18, 24, 36, 42, and 48 to the crate. Most of the crop is moved during June and July.

CULTIVATION.

Until some time after the plants have borne their first crop the field can be cultivated, but when the fields are three or four years old the ground is covered with a mass of plants, and no cultivation is required, or, in fact, possible.

Cultivation of the young fields is done by hand, using a scuffle hoe. After each application of fertiliser the ground becomes crusted, and cultivation should immediately follow. Weeds are likely to start, though neither so numerous nor so troublesome as on heavier soils, and must be destroyed. Cultivation of the young plants is distinctly an advantage; the difference between thorough and poor cultivation is very evident.

FERTILISERS AND FERTILISING.

From the very character of the soil it will be seen that fertilisers must be used in considerable quantities—in fact, the whole culture of the crop is based upon their proper use. Experiments with fertilisers have been conducted by the Florida Experiment Station continually for a number of years, and the results for several years have already been published. A glance at the analysis of the soil shows that the land is almost ideal from such a line of

investigation. It supplies a medium for the roots to grow in, with but little plant food of any kind; hence the results obtained may safely be said to be due in an unusual degree to the fertiliser applied.

ANALYSIS OF THE PLANT.

The average analysis of the plant, leaves, and stem shows it to contain '826 per cent. phosphoric acid, '681 per cent. nitrogen, and 1'345 per cent. potash, while the average of forty-eight analyses of the fruit is: '42 per cent. phosphoric acid, '070 per cent. nitrogen, and '225 per cent. potash. The fact is noteworthy that potash is an extremely important element in both plant and fruit. Both actual analysis and experimental evidence show that the plant foods, phosphoric acid, nitrogen, and potash should enter into the composition of the fertiliser in the proportion of 4 and 5 to 10, or 4 per cent. phosphoric acid, 5 per cent. nitrogen, and 10 per cent. potash. In the fertilising of many crops nice differences in the effects of fertilisers are not apparent. Not so with the pineapple in Florida soils, as it has been distinctly shown that all sources of plant food are not equally desirable.

Sources of Phosphoric Acid.—As sources of phosphoric acid, ground bone, raw or steamed, and slag phosphate have given excellent results. Acid phosphate has invariably produced a condition known as "spike." This is characterised by poor growth, narrow, constricted, greasy-looking leaves, and worthless fruit. Unless the condition is corrected, the plants die. When applications of lime were made with acid phosphate, the plants remained healthy and appeared entirely normal. On the whole, however, it is doubtless best to avoid the use of acid phosphate.

Sources of Potash.—Potash has an important bearing on the quality of the pineapple fruit. When supplied in too small quantities, the fruit is deficient in juice and lacking in quality. Unless present in the soil in available form in large amounts, it must be supplied to secure desirable results. The fertiliser should contain at least 10 per cent. potash. The effects of different potash salts are noteworthy. It was shown that those free from chlorides—viz., sulphate of potash, magnesia, and high-grade sulphate of potash—were the best sources. Plants fertilised with both muriate of potash and kainit (both contain chloride) developed "spike." "Manure salts" were not used, but these grades would doubtless produce the same results as kainit.

Both from the experiments already referred to and from field results obtained by different growers, we can recommend dried blood, cotton-seed meal, and castor pomace as good sources of nitrogen. Nitrate of soda and sulphate of ammonia produce spike.

Plants grown with a fertiliser in which all the nitrogen was derived from nitrate of soda were deficient in fibre, with poor crowns and poor carrying quality.

Size of Fruit Affected by Fertiliser.—As the amount of fertiliser is increased up to a certain amount, the increased application resulted in larger, more robust plants, and larger fruit. Large fruit, besides increasing the total acre yield, bring a better price in the market.

When a fertiliser containing slag phosphate, dried blood, and high-grade sulphate of potash, analysing 4 per cent. phosphoric acid, 5 per cent. nitrogen, and 10 per cent. potash, was applied to plots at the rate of 2,250 lb., 3,000 lb., and 3,750 lb. respectively per acre, the yields per 100 plants were as follow:—

| | SIZE. | | | | |
|---------------------------|-------|----|----|----|----|
| | 18 | 24 | 30 | 36 | 42 |
| 2,250 lb. per acre | 1 | 9 | 43 | 35 | 10 |
| 3,000 " " | 2 | 22 | 59 | 14 | 0 |
| 3,750 " " | 0 | 50 | 35 | 12 | 0 |

The most desirable is the 24 size, while 42nds are not worth nearly as much. In size of 24's we mean that it takes twenty-four plants to produce a crate of fruit. Likewise, by 42nds is meant forty-two plants per crate. The measure of the size of the fruit is in a large degree the measure of the yield. In the experiments already referred to, it was proved that the most profitable application of fertiliser is from 3,500 to 4,000 lb. per acre annually.

Number of Applications.—During the first eighteen months after the plants are set out, four applications should be made. Afterwards two or three applications per year are the best. For very light soils three are preferable, one in February, one in July, after the crop is removed, and one in November. In sections subject to frost, all, or nearly all, nitrogen should be omitted from the fall application. The nitrogen fertiliser is likely to start growth prematurely, which potash and phosphoric acid will not do.

Amount of Fertiliser Materials.—If it is desired to mix the fertiliser at home, one of the following formulas can be used as providing approximately the required composition of 4 per cent. phosphoric acid, 5 per cent. nitrogen, and 10 per cent. potash, and will give excellent results:—

- (1) 800 lb. bone meal, 575 lb. dried blood, 400 lb. high-grade sulphate of potash, 225 filler.
- (2) 800 lb. bone meal, 575 lb. dried blood, 800 lb. sulphate potash magnesia.
- (3) 900 lb. bone meal, 1,000 lb. cotton-seed meal, 500 lb. high-grade sulphate of potash.—“Tropical Life.”

APRICOT-GROWING IN BRISBANE.

It is very rare to find apricot trees in the neighbourhood of the coast setting their fruit, but that they will do so in isolated cases, and bear heavily, is shown by the results obtained this year by Mr. H. Slaughtcr, on the Deighton Estate, South Brisbane. A tree in his garden, of uncertain age, has grown to a height of 18 ft., with a spread of branches 36 ft. in diameter. This tree has borne and ripened its fruit on previous occasions, but this season it excelled itself, and has produced a very heavy crop. The fruit is not as large as that produced in the orchards of the Darling Downs and at Stanthorpe, but it is of good flavour, and makes excellent jam. Two trees growing in a garden at Milton, which are over six years old, blossomed freely this year, but produced no fruit.

EXPORT OF FRUIT FROM SOUTH AFRICA.

A shipment of oranges from Port Elizabeth, South Africa, to London has proved highly successful, and this will doubtless lead to an extensive trade in this fruit between the two countries. The shipment, on arrival, was thus reported on by the Trades Commissioner, London:—“(a) 150 cases navel oranges, each containing fifteen fruits. These arrived in excellent condition and well packed, although the boxes were rather too large for the quantity of fruit they contained. The fruit was very sound and beautiful, and these were probably the best navel oranges seen on Covent Garden this season. They realised £32 17s. 6d., or 4s. 4½d. per box, which is equal to 29s. 2½d. per hundred, or about 3¼d. each. I hope that shipments of this class of orange will be much increased. (b) 100 cases ordinary or Jamaica oranges, containing counts of 96 to 112. They realised 8s. to 12 per case. They arrived generally in a sound condition, only about 5 per cent. being wastv. They were well packed, but in future it would be an advantage if they were more tightly packed.”

Horticulture

FLOWER GARDENING, No. 12.

By THE EDITOR.

PLANTS SUITABLE FOR IN AND OUT DOOR CULTURE.

PRIMULA (Chinese Primrose).

The Primulæ are beautiful tender perennials, suitable only for pot-culture. The flowers are of good size and perfect form, combined with brilliant and charming colours. Seedlings, raised in pots in the autumn, should, as soon as the plants are fit, be transplanted. Pot them off into small pots, and place them in a bush-house. As soon as they are again well rooted they should be shifted into blooming pots. The best way to sow the seed is to prepare a soil composed of 2 parts of rotten loam, 1 part of partly rotten peat mould, 1 part decayed cow manure, and a little silver sand. Just cover the seed with some light material such as sifted jadoo fibre, water lightly but thoroughly, then place in the shade, after treatment as above.

POLYANTHUS PRIMROSES.

These beautiful, hardy hybrid Polyanthus produce through the spring a wealth of bloom, which can hardly be surpassed for beauty and richness of colouring. Amongst them will be found lovely shades of crimson-maroon, rich purple and deep orange passing through many charming variations of colour to the palest primrose and pure white. The fern-leaved varieties of Primula, known as *Primula fimbriata filicifolia*, are very elegant, with their beautiful divided foliage and splendid, large-fringed flowers.

VARIETIES.

Primula sinensis fimbriata—Single Fringed, Double Fringed, Chiswick Red; *Alba magnifica marginata*—Blue Fringed; Auricula (Alpine); English Primrose; Oxlip; Cowslip; *Primula japonica*—Polyanthus, gold-laced, &c.

DAISY.

These old favourites can be easily grown from seed. They should be sown in a shallow box, filled with light soil, and kept well watered; a cool position will suit best. The seedlings must be planted out when large enough to handle. They are hardy perennials. Sow during autumn and spring.

VARIETIES.

Longfellow, Giant Snowball, Fistulosus (double), Delicata.

MARIGOLD.

This old familiar plant of English gardens should not be omitted from the Queensland flower garden, where it will grow to perfection. It may be had of many varieties of colour, from pale straw to deep orange, single and double. It is a somewhat difficult plant to transplant without injury. It is best, therefore, to sow the seed in the border where the plants are to remain. It does not require a very rich soil, and, when full grown, rejoices in the full blaze of the sun. Marigolds are very hardy, and are constant bloomers. The French varieties have beautifully-shaped orange flowers, striped and flaked with brown. The African varieties have very large self-coloured flowers; all are annuals.

VARIETIES.

French Dwarf, mixed colours; French Yellow, double sulphur yellow; African Lemon; African Orange; Meteor, double, beautiful golden colour.

MARTYNIA.

This is a beautiful sweet-scented, hardy annual. It has beautiful crimson-purple flowers, and makes a nice showy pot-plant. Its gloxinia-like flowers are succeeded by curiously double-horned and hooked seed-pods. Sow in the spring.

VARIETIES.

M. fragrans, crimson-purple flowers; *M. lutea*, yellow; *M. proboscidea*, rose.

LARKSPUR.

One of our most valuable hardy annuals, very effective in mixed borders and amongst shrubs. The flower spikes are from 6 to 8 in. long, and the flowers themselves are of many beautiful shades of colour. Sow in light, loamy soil where the plants are intended to remain. If allowed to shed the seed, numbers of plants will spring up in the early spring. Larkspurs are both annual and perennial. They are constantly in bloom, and are of great value for cutting.

VARIETIES.

Double Emperor; double tall German Rocket; Ranunculus-flowered; Stock-flowered; Dwarf German Rocket; Giant Hyacinth-flowered; Candelabrum.

BORONIA.

This is indigenous in Australia, and among the sweetest-scented plants takes a foremost position, and a whiff of its delicious perfume, which is that of the cowslip greatly intensified, is something not readily forgotten. The boronia belong to the hard-wooded section of plants. It is advisable to buy plants in spring, just about the time they are showing their buds, and I will take this as a starting point in my remarks on culture. Place the plants on a nice light soil and attend carefully to watering, so that the roots are never allowed to get quite dry, neither must they be kept over-watered—failure to observe these items fully being sure to lead to disaster. After flowering let the soil get a little on the dry side; then cut the plants down to within three joints of the last pruning or stopping. For some weeks progress will be slow, and very little water must be given, though it may be increased very gradually as growth is made. The plants may be put out on a bed of ashes in a garden frame, from which the light should be drawn off in all weathers except when rain is falling; the exposure they thus get to air, light, and the night dews finishes up the wood and sets the flower buds. Any plants which appear to require potting should be taken in hand just as the season's growth is completed, as roots are then formed most readily. Take care not to over-pot, as the very slender-foilage plants do not require a great body to support them, and, if given, it only turns sour.

The best soil is good peat and light, fibrous loam in equal proportions and pulled up into small lumps, which may readily be rammed into the small space between the ball (which should be lifted intact except for the removal of the drainage at the bottom) and the sides of the pots. Mix with the soil sufficient silver sand to make it feel gritty and to keep it open and porous.

Pot firmly and solid, adding only a little soil at a time, so that no hollow spaces may be left, and elevate the ball so that none of the stem is buried below the old soil line. Drain the pots carefully with one large piece of potsherd placed with the concave side downwards, and so trimmed with the hammer that it will not rock when in position. This should be covered with $\frac{1}{2}$ -in. of small pieces, and on this again, to receive the base of the ball, should be placed a little of the most fibrous soil. The pots should be clean, and the plant should

have a soaking of water some hours before it is potted; then, if the new soil is in that best of conditions known as "neither dry nor wet," no more water will be needed for a few days. Where the plants are grown in large batches they are frequently given a night temperature of 55 degrees to aid the young shoots after they have broken well; but I do not advise this if, to get the extra few degrees of heat, they have to be put with a mixed collection of plants.

Those who wish to propagate their own plants may take off the young cuttings when about 2½ in. long. If a slight heel of the old wood can be left at the base, or "slips" instead of cuttings are made, they will be all the more readily struck, but cuttings of the ordinary type will also root. Well drain some 5-inch pots, fill up to within an inch of the rim with sandy soil of the same nature as recommended for potting, except that it should be sifted fine. On this again put about ½-in. of pure silver sand, then dibble in the cuttings, water in lightly, and when the foliage has become dry cover the pots with bell-glasses in a temperature of 50 degrees; shade the glasses from bright sun until the cuttings have struck. Very little water will be needed, and what little is given should be poured gently round the pots just inside the rims, to prevent the centre from becoming too wet. Pot off singly into small pots as soon as well rooted, nurse carefully till established, and then commence to form the desirable bush shape by pinching out the points of the shoots as they lengthen out, repeating this as often as necessary to attain that object.

NEMOPHILA.

Where a splendid mass of blue is the object for a couple of months in autumn, this is a most effective plant. It quite eclipses lobelia when seen at a distance, and is one of the generally useful dwarf-growing, hardy annuals. It is very compact in growth, and shows a great variety of colour, which is of a deep, ultra-marine blue, with zone of black purple round the small white centre, in the *Nemophila insignis* and *N. atomaria atrocerulea*.

OTHER VARIETIES.

N. maculata, flowers white and brown spotted; *N. discoidalis*, black-brown; *N. marginata*, blue with white edge.

LUPINS.

Of these annuals there are a great many species and varieties, all more or less beautiful. Their fault is that they run to seed too rapidly. The seed should be sown in autumn and spring. Lupins will grow well in any ordinary garden soil. They will bear transplanting, but it is safer to sow the seed where the plants are intended to remain. The pea-shaped flowers on their long graceful spikes are of rich and varied colours. The tall varieties are effective in borders, and the dwarf in beds. They are very useful for cut flowers. The yellow lupin is very pretty, with sweet-scented flowers.

L. arboreus is suitable for mixed borders or shrubbery. Sow the seeds 3 to 8 in. apart. The plants require scarcely any water, and grow fast. To save seeds, when the pods on the lower part of the flower-stalk have grown to nearly their full size, the tops of the stalks should be pinched off, when, if the plants are not exposed to too hot a sun, the seeds will ripen gradually and remain plump.

VARIETIES.

L. Hartwegi, a very pretty blue; Yellow Tree Lupin, large yellow; *Dunnetti superbus*, purple, yellow, and white; *L. hybridus atro-coccineus*, crimson, scarlet, white-tipped; *L. luteus*, the well-known old yellow Lupin with speckled seeds.

EVERLASTINGS.

Everlastings are curious for the rather large, dry husky flowers they bear. The flowers remain unchanged for many months, and are often used as an

indoor decoration. They grow to 2 or 3 ft. high, and require no particular care. They suit our climate admirably, and produce quantities of flowers of great beauty, white, yellow, rose, and crimson. Sow during Autumn and Spring.

VARIETIES.

Roseum, double rose; *Alba, fl. pl.*, pure white; *Compositum purpureum, fl. pl.*, double, crimson; Fireball; Silverball, crimson and silver white.

MIGNONETTE.

No particular directions need be given for the culture of this familiar, sweet-scented plant, except that it bears transplanting ill, and that the seed should be sown during April, or during August and September, in patches where the plants are to remain. Mignonette may be kept alive and in blossom a very long time if the flower heads be cut off when they begin to form seed vessels. It will succeed in nearly any soil, and, in gardens where it has been grown for one season, it will come up self-sown in the following. It delights most in a sandy loam, not too light; but, being a gross feeder, a little diluted liquid manure may be given it once a week with advantage. Many of the varieties make excellent pot-plants, and produce spikes of immense size. To form what is called the

TREE-MIGNONETTE.

proceed as follows:—Sow in a 4-in. pot. When up, clear off all the plants but the one in the centre. As it grows, train it upwards to a stick, until it is 1 ft. high, or 2 ft., if you please. Do not allow any side-shoots to grow on the stem, and remove all leaves to within a few inches of its top. When the plant gets as high as you wish, top it, and then it will throw out side branches. As they advance, pinch off their tops, till you have formed a nice bushy head to your plant; and, above all, do not allow any bloom to appear until it has become strong.

VARIETIES.

Reseda odorata, large-flowering, sweet-scented, greenish; Crimson Queen has a beautiful crimson-red flower spike; Golden Machet, large spikes of golden-yellow flowers; Bismarck, an improved Machet, a strong grower, 1 ft. high, very broad flower spikes of a reddish tinge; Machet, dwarf, red flowers; Golden Queen, of pyramidal habit, bright yellow flowers.

ALYSSUM.

A. maritimum (Sweet Alyssum), a pretty fragrant, white flower, very useful for forming borders, also for masses. It is a hardy annual, bears flowers in great profusion, and, if cut down after flowering, a new growth will be promoted.

VARIETIES.

A. saxatile is a dwarf, showy, hardy perennial, having yellow flowers and hoary leaves; *Maritimum compactum* (Little Gem), very dwarf, erect variety; *A. saxatile* is valuable for rock-work, edgings, and mixed borders. Sow in autumn or spring.

VERBENAS.

Verbenas love a soil well enriched with vegetable mould. The tendency of the stems to throw out roots, wherever they rest upon the earth, sufficiently indicates that it requires frequent renewal of soil. From their trailing habit, when put out in the border, verbenas usually have an untidy appearance. Small circular or oval beds, each filled with a distinct variety, have a most charming and glowing effect during the very long time the plants last in the full height of their bloom. To propagate them, take cuttings or layers from the old plant, remove the two bottom leaves and dibble them in 1 in. apart. When they have made roots about 1 in. long, they may be planted out. Do

not give them too much water, but they must not be allowed to get too dry. They are more likely to suffer injury from drought than from a little overdose of water. Sow in autumn or spring.

VARIETIES.

Coccinea, a beautiful glowing scarlet; Auricular-flowered, various colours; *Coerulea*, shades of blue, very effective; *Candidissima*, pure white; *Striata*, carnation-striped; *Venosa*, blue.

LAVENDER.

The Lavender is the most popular of all perfume plants. Although the plant may be easily raised from seed, the principal method of propagating it is by cuttings or slips. The cutting should be of clean, fresh growth, about 4 to 5 in. in length; the side leaves should be taken off, leaving only the top one or two which are exposed. These should be planted in sandy mould in a frame or box, and supplied with a slight bottom heat, which will assist considerably in getting the young plants started into a healthy and vigorous growth.

The plant grows under almost any conditions. In some parts of the State it becomes quite a coarse shrub. It can withstand great hardship. The late Baron von Müeller stated that it grows well in Norway, in latitude 59 degrees 55 minutes. Yet, with slight shade, it can be grown equally well in temperate and tropical countries. There are few varieties of this flower, amongst them are:—*Lavendula Stoechas*, or Topped Lavender; *Lavendula Vera*, and *L. Spica*. Of these the *Vera* is the best. The plant will remain in bloom for four or five months.

FLOWER GARDEN CALENDAR.

JANUARY.

Roses may still be budded during this month. Annuals for Autumn planting should be sown in pots or shallow boxes in a shady part of the bush-house. Now is the time to prepare for making the flower beds gay and attractive during the autumn and winter months. Fill the boxes with compost, then sow thinly the seeds of annuals. All kinds of shrubby plants may be propagated by cuttings. Thus, pelargoniums, crotons, coleus, and many other kinds of tropical foliage plants can be obtained from cuttings made this month. After putting out cuttings in a propagating frame, shade them with a piece of calico stretched over it. Be careful not to over-water at this season. Propagate verbenas. These require rich soil. Layer carnations, picotees, and pinks. Do this in dry weather, as the stems, being less brittle, are not so liable to break; give the bed a good soaking of water after they are done. Tie up dahlias, hollyhocks, climbers, and other tall plants. Palms may be planted out during this month.

FEBRUARY.

Thin out and tie up dahlias. Keep the weeds down. Sow hardy annuals. This is the best month for sowing, as you will be able to keep up a succession of bloom during the succeeding months of Autumn and Winter. To ensure this, sow phlox, pansy, daisy, stocks, aster, nasturtium, hollyhock, candytuft, mignonette, sweet peas, dianthus, carnations, cornflower, summer chrysanthemums, verbenas, petunias, pentstemons, &c. Dianthus, sown now, and planted out in March, will bloom during the whole year, if the dead stalks and blooms are regularly cut away. Plant out stocks, gaillardias, calliopsis (coreopsis), balsams, &c. Water pot-plants morning and evening.

MARCH.

Now is the time to plant out bulbs. A complete garden could be furnished with these charming plants, which are to be had in every colour and variety.

Amongst the many are—*Amaryllis*, *anemone*, *arum*, *babiana*, *crinum*, *crocus*, *freesia*, *ranunculus*, *jonquils*, *iris*, *ixias*, *gladiolus*, *narcissus*, *Jacobean lilies*, *tigridia*, *tritonina*. All bulbs like well-drained, somewhat sandy soil, with a plentiful admixture of leaf mould.

Herbaceous plants and annuals, which it is intended to raise from seed, should be sown this month. Such are—*Antirrhinum* (Snapdragon), *asters*, *cornflowers*, *dianthus*, *larkspur*, *daisies*, *cosmia*, *candytuft*, *lupins*, *gaillardias*, *godetia*, *mignonette*, *poppies*, *pansies*, *phlox*, *sweet peas*. *Cannas* now planted will require plenty of food in the shape of liquid manure.

Put in cuttings of carnations. Layer shrubs and roses. *Chrysanthemums* require attention in the way of disbudding, staking, watering with liquid manure, &c. Now, as to climbers which may be planted during March. These are—*Allamanda Schottii*, *Antigonon leptotus*, *Aristolochia elegans* and *A. ornithosephala*, *Asparagus plumosa*, *Beaumontia grandiflora*, *Bignonia*s of several kinds, *Bougainvilleas*, *Quisqualis Indica*, *Wistaria*, *Bauhinia scandens*. Prune roses, and plant the cuttings in a shady place.

APRIL.

The operations this month will depend greatly on the weather. If wet, both planting and transplanting may be done at the same time. *Camellias*, *gardenias*, &c., may be removed with safety. Plant out all soft-wooded plants, such as *verbenas*, *petunias*, *pentstemons*, &c. Sow annuals as during last month. Those already up must be pricked out into other beds, or into their permanent positions. Growth just now will not be too luxuriant, and shrubs and creepers may be shortened back. Always dig the flower beds rough at first, then apply manure, dig it in, and, after this, get the soil into fine tilth. Land on which you wish to raise really fine flowers should have a dressing of bonedust lightly turned in. Wood ashes also form an excellent dressing. Prune out roses. These may be planted out now with perfect success. Take up *dahlia* roots, and plant bulbs as recommended for March. *Fuchsias*, *heliotropes*, and *verbenas* may be struck from cuttings; carnations, *picotees*, *pinks*, &c., from cuttings or pipings. Layers that have made sufficient roots should now be gradually severed from the plant, and left for a fortnight before potting, to ripen the young roots.

MAY.

Continue planting and transplanting simultaneously as during last month. The plants will thus be fully established before the early frosts set in. Cut back, and prune all shrubs ready for digging. Take up whatever *dahlia* roots are still in the ground, and place in a shady place out of doors. Plant bulbs, such as *anemones*, *ranunculus*, *snowflakes*, *freesias*, *ixias*, *iris*, *narcissus*, &c. *Tulips* and *hyacinths* may be tried, but success in this climate is very doubtful. All shades and screens may now be removed to enable the plants to get the full benefit of the air. Fork in the mulching, and keep the walks free from weeds. Slip hedges and edgings. Pot plants should have very little water during the coming winter. Prune roses in accordance with directions under that head.

JUNE.

No time is now to be lost, for many kinds of plants require to be planted out early to have the opportunity of rooting and gathering strength in the cool, moist Spring time to prepare them for the trial of heat they must endure later on. Do not put your labour on poor soil. Raise only the best varieties of plants, for it costs no more to raise good varieties than poor ones. Prune closely all the hybrid perpetual roses, and tie up, without pruning, to trellis or stakes, the climbing and tea-scented varieties, if not already done. These and other shrubs may still be planted. See where a new tree or shrub can be

planted, and get them in position; then they will give you abundance of Spring bloom. Renovate and make lawns as previously directed, and plant all kinds of edging. Finish all pruning. Divide the roots of chrysanthemums, perennial phlox, and all other hardy clumps. Cuttings of all Summer bedding plants may be propagated. Use the ends of the young succulent shoots of petunias, torenias, heliotropes, verbenas, &c. Pot off such cuttings as have struck. Any dahlias yet remaining in the border should be taken up and stored as directed. Put in well-ripened cuttings of pelargoniums in porous soil. Sow a first lot, in small quantities, of hardy and half-hardy annuals, biennials, and perennials, some of which are better raised in boxes, and transplanted into the open ground, but many of this class can, however, be successfully raised in the open border, if the weather is favourable. Antirrhinum, carnations, picotees, dianthus, hollyhock, larkspur, pansy, petunia, Phlox Drummondii, stocks, wall-flower, zinnias, &c., may be sown either in boxes or open beds; mignonette is best sown where it is intended to remain.

JULY.

Winter work ought now to be in an advanced state. The roses will now want looking after. They should already have been pruned, and now any shoots which have a tendency to grow in wrong directions should be rubbed off. Overhaul the ferneries, and top-dress with a mixture of sandy loam and leaf mould, staking up grown plants, and thinning out others. Treat all classes of plants in the same manner as the roses, where undesirable shoots appear. All such work as trimming lawns, digging beds, pruning and planting, should now be got well in hand. Plant out antirrhinums, pansies, hollyhocks, verbenas, petunias, &c., which were lately sown. Sow zinnias, amaranthus, balsam, chrysanthemum tricolour, marigold, cosmos, cockscombs, phloxes, sweet peas, lupins, &c. Plant gladiolus, tube-roses, amaryllis, pancratium, ismene, crinums, belladonna, lily, and other bulbs. Dahlias will now start, and be ready for planting out in August and September.

AUGUST.

Continue to look over the roses, and encourage them in the way they should go by rubbing off any shoots which tend to grow towards the centre. Where there is a fine young shoot growing in the right direction, cut off the old parent branch which it will replace. Trim and repair the lawns. Any roses, camellias, azaleas, &c., intended to be grafted, should now be done. Plant out and sow as directed for July. Plant any dahlias which may have formed strong shoots, but it is better to defer planting dahlias to the two succeeding months. It must be remembered that this is the driest of our months. Plants in the conservatory should be re-potted, as well as those in the green and bush houses, if only to renew the soil, and those that are to be encouraged to vigorous growth should be shifted frequently into larger pots, as the roots reach the sides. Be careful not to give them too much water.

SEPTEMBER.

The planting of bulbs should be continued as directed for the two previous months. Protect the plants as much as possible from cold westerly winds, which may still occur. Indeed cold winds, and even heavy frosts, sometimes occur even in October, as happened in 1908. Keep a good look-out for slugs. Plant out chrysanthemums, palms, and all kinds of tropical and semi-tropical plants. If hot weather should ensue after planting, water and shade must be given. Sow dianthus, coleus, snapdragon. Roses will now be in full bloom. Keep them free from aphids, and cut off all spent blooms. The latter work should be done in the case of all flowers. If you wish to save seeds, do not

wait for the very last blooms, but allow some of the very best to go to seed. If you have any toads in the garden or bush-house, encourage them to take up their abode there. (See the note on the value of toads, in Vol. IV., February, 1899.) Fill up all vacancies with herbaceous plants. Plant dahlias in rather dry soil well enriched with old manure. Sow zinnia, gaillardia, amaranthus, cockscomb, balsam, sunflower, marigold, cosmos, summer chrysanthemum, calliopsis (coreopsis), portulacca, mesembryanthemum, calendula, &c. When planting dahlias, each plant should be supported by three stakes in a triangle. Layer camellias, rhododendrons, azaleas, magnolias, &c. Support the spikes of gladiolus now in bloom, by sticks where the plants are exposed. In dry weather, water camellias copiously, the soil being well mulched to prevent it binding, and to keep off the sun. They are greatly benefited by being well "bushed" during the first year after planting. They will not suffer if the shade is even dense, so long as it is above, and does not smother them.

OCTOBER.

The flower garden will now be showing the result of the care bestowed upon it during the past two months. The principal work to be done this month is the raking and stirring of the beds, staking, shading, and watering. Annuals may be sown as directed for last month. Plant chrysanthemum, gladiolus, and other bulbs, such as tuberose, crinum, ismene, amaryllis, pan-cratum, hermocallis, hippeastrum, dahlias, &c. Water seedlings well after planting, and shade for a few days. Roses should now be in full bloom. Keep them free from aphids, and cut off all spent flowers. Get the lawn-mower out, and keep the grass down. Hoe the borders well, and trim the grass edges. Layer pelargoniums as soon as the shoots are ripe, as they root freely at that stage. Stop chrysanthemums regularly as they throw out their lateral shoots, as soon as they are 2 in. long, to make the plants more dwarf and compact, and give them a little liquid manure occasionally before they come into bloom.

NOVEMBER.

Stake any dahlias which may now be above ground, and plant out the bulbs which were stored in a moist place. If the weaker bulbs are reserved, they will come in for Autumn planting. Take up all bulbs which have done flowering, and store them in a dry place. Winter-flowering plants will have almost gone off; still, the garden should be in full bloom, and will well repay the trouble bestowed upon it, and a little fertiliser given as a top-dressing will assist the plants to bloom, and look well for a longer time than if they were neglected. Give weak liquid manure to chrysanthemums, and allow no suckers to grow till the plants have done flowering. Take up narcissi. Do not store them, but plant them at once in new situations. Sow antirrhinum, balsam, zinnia, summer chrysanthemums, calliopsis (coreopsis), and nemophila. At the end of the month a few roses may be budded. Layer pelargoniums.

DECEMBER.

Keep the surface of the soil well stirred. Bud roses. A few annuals may still be sown, such as balsams, calendulas, cosmos, calliopsis (coreopsis), marigold, nasturtium, portulacca, zinnia, and cockscomb. Plant out whatever amaranthus may be ready. These may still be sown in boxes. Clear away all annuals which have done flowering. Bulbs should have all the dead leaves cut away, but the green leaves should not be touched. Stake chrysanthemums, and as the flower-buds develop give them weak liquid manure. Coleus may now be planted and propagated from cuttings. Propagate carnations, picotees, pinks, &c., by cuttings, pipings, or layers.

Botany.

CONTRIBUTIONS TO THE FLORA OF QUEENSLAND.

By F. MANSON BAILEY, F.L.S., Colonial Botanist.

Order LEGUMINOSÆ.

ACACIA, Willd.

A. dineura, *F. v. M.*, Journ. Linn. Soc. III., 130; *Fragm.* XI., 65.; *Flora Austr.* II., 391; *A. binervata*, DC., form *dineura*. A glabrous tall shrub or small tree. Phyllodia more or less glaucous-falcate, 2 to 4 in. long, 6 to 9 lines broad, glandular-obtuse at the end; longitudinal nerves two or three prominent, reticulate veins close and prominent, some often joining and forming intermediate longitudinal nerves, marginal gland near the base sometimes, perhaps, wanting; the inflorescence appearing like a terminal leafy panicle, 6 in. long and broad, from the close erecto-patent racemes of globose flower-heads at the ends of the branches. Racemes, 2 or 3 in. long, slender; peduncles very slender, about 6 lines long; globose head of flowers about 3 lines diam., flowers numerous, 5-merous; calyx ciliate, much shorter than the corolla. Pod flat and thin, about $3\frac{1}{2}$ in. long, 5 lines broad, prominently raised over the seed, more or less stipitate, pointed at the end. Seed sub-lentiform, 2 lines diam.; funicle folded and dilated under the seed, but not surrounding it, in some of the dry pods appearing slender and straight.

Hab.: Stannary Hills, *Dr. Thos. L. Bancroft*.

The above description differs from Baron Mueller's diagnosis, in *Fragm.* and figure, in his "Iconography of Acacia"; however, I think there can be little doubt of its being identical with the species here given.

Order RUBIACEÆ.

PAVETTA, Linn.

P. tomentosa, *Sm.*; *W. and Arn.* = *Ixora tomentosa*, *Roxb.* A tall shrub or small tree closely allied to *P. indica*, Linn. Leaves coriaceous when old, lanceolate, about 3 in. long and nearly 1 in. broad, pubescent on both faces, crowded at the ends of the branches. Flowers in small dense corymbs, lateral or appearing so from the growth of the shoot, the whole inflorescence and calyxes hoary-tomentose. Calyx-limb small, with minute teeth. Corolla, fruit, and seeds of *P. indica*.

Hab.: Stannary Hills, *Dr. Thos. L. Bancroft*.

Sir J. D. Hooker, in *Fl. of Brit. Ind.* III., 150, places this plant as a variety of *P. indica*.

Order PROTEACÆ.

TRIBE, EMBOTHRIEÆ.

STENOCARPUS, R. Br.

S. Cunninghamii, *R. Br.*, *Prot. Nov. Fl. Austr.* V., 510. A graceful tree, about 20 ft. high; diameter of stem at base, 5 in. Branchlets slender, dark, angular, more or less hoary when young. Leaves usually erect, linear, 2 to 7 in. long, 2 to 3 lines broad, tapering towards the base, entire or sometimes

bearing a few lobes similar to the entire leaves, the apex bluntly or elongate-acuminate, midrib and venation often faint, the longitudinal nerves from 3 to 6. Inflorescence terminal on the short shoots near the ends of the branchlets, whitish from being clothed with silvery hairs. Bracts short narrow-lanceolate. Peduncles very slender, 1 to 2 in. long, often bearing a few scattered flowers below the terminal umbel; flowers in each umbel, from 12 to 20; pedicels, 4 or 6 lines long. Perianth-tube 3 lines long, limb globular, 1 line diameter. Ovary and stipes silky-pubescent, style glabrous, furrowed; stigma dilated, hypogynous glands hippocrepiform within the prominent surrounding cup. Follicle, 2 to 3 in. long, stipitate, before expansion 3 lines broad, brown with numerous longitudinal nerves, swelled over the seeds, giving to the follicle the appearance of a 4 or 5 seeded legume.

Hab.: Stannary Hills, *Dr. Thos. L. Bancroft.*

This little known species has not previously been met with in Queensland.

Statistics.

COMMONWEALTH METEOROLOGY. RAINFALL OF QUEENSLAND.

TABLE SHOWING THE TOTAL RAINFALL FOR EACH MONTH OF THE YEAR IN THE AGRICULTURAL DISTRICTS OF QUEENSLAND.

| STATIONS. | 1907. | | 1908. | | | | | | | | | | |
|--------------------------|-------|-------|-------|-------|-------|--------|-------|-------|-------|------|-------|------|------|
| | Nov. | Dec. | Jan. | Feb. | Mar. | April. | May. | June. | July. | Aug. | Sept. | Oct. | Nov. |
| <i>North.</i> | | | | | | | | | | | | | |
| Bowen | 3.71 | 6.39 | 10.14 | 5.63 | 9.46 | 3.73 | 0.99 | 0.45 | 0.88 | 0.51 | 0.96 | 2.47 | 0.42 |
| Cairns | 5.35 | 28.33 | 27.02 | 8.03 | 20.60 | 5.99 | 3.05 | 0.59 | 3.70 | 2.12 | 0.74 | 3.07 | 1.60 |
| Geraldton | 6.45 | 33.82 | 44.39 | 13.27 | 39.00 | 14.23 | 18.52 | 2.64 | 8.11 | 3.66 | 2.81 | 6.93 | 3.80 |
| Gindie State Farm | 1.57 | 4.42 | 0.20 | 7.17 | 6.25 | 0.02 | 0.112 | ... | 0.40 | 1.27 | ... | ... | ... |
| Herberton | 3.41 | 9.57 | 9.29 | 5.02 | 8.92 | 1.40 | 0.38 | 0.31 | 2.36 | Nil | 0.51 | ... | 0.61 |
| Hughenden | 0.68 | 7.75 | 0.98 | 5.18 | 6.91 | 0.30 | Nil | 0.05 | 0.68 | Nil | Nil | 1.67 | 1.94 |
| Kamerunga State Nurs. | 2.78 | 20.82 | ... | 7.47 | 25.75 | 4.60 | 3.363 | 0.76 | 4.85 | 1.53 | ... | 3.64 | 1.69 |
| Mackay | 5.76 | 9.70 | 9.28 | 3.33 | 17.43 | 14.82 | 3.25 | 1.29 | 1.65 | 0.71 | 2.27 | 1.80 | 2.57 |
| Rockhampton | 3.72 | 4.42 | 3.84 | 9.64 | 9.77 | 2.62 | 0.85 | 0.10 | 1.08 | 0.84 | 0.20 | 2.14 | 2.47 |
| Townsville | 2.82 | 24.26 | 12.21 | 6.69 | 9.03 | 0.38 | 2.22 | Nil | 1.70 | 0.27 | 0.28 | 1.58 | 1.26 |
| <i>South.</i> | | | | | | | | | | | | | |
| Biggenden State Farm | 2.50 | 5.55 | 2.37 | 9.82 | 9.84 | 2.97 | 0.74 | 0.43 | 0.49 | 2.33 | 1.39 | 1.80 | 2.12 |
| Brisbane | 4.25 | 3.21 | 2.80 | 8.43 | 18.19 | 2.45 | 2.40 | 0.17 | 0.77 | 2.83 | 0.67 | 1.77 | 2.25 |
| Bundaberg | 2.90 | 2.99 | 4.77 | 2.82 | 7.35 | 4.13 | 0.67 | 0.39 | 0.75 | 1.56 | 1.10 | 2.39 | 0.73 |
| Dalby | 5.18 | 1.44 | 0.17 | 4.88 | 7.61 | 0.11 | 0.37 | 0.63 | 0.14 | 1.80 | 1.13 | 2.55 | 3.65 |
| Esk | 3.76 | 3.72 | 2.61 | 10.06 | 17.04 | 2.83 | 1.07 | 0.23 | 0.46 | 2.75 | 2.16 | 1.29 | 3.99 |
| Gatton Agric. College | 3.01 | 4.55 | ... | 3.38 | 10.74 | ... | 0.10 | 0.16 | 0.6 | 2.71 | 1.84 | 1.93 | 5.71 |
| Gympie | 3.05 | 5.49 | 6.26 | 11.77 | 8.08 | 1.87 | 2.00 | 0.38 | 1.16 | 2.87 | 1.37 | 2.49 | 2.58 |
| Ipswich | 4.45 | 3.40 | 1.32 | 6.63 | 13.77 | 2.71 | 1.14 | 0.12 | 0.47 | 3.23 | 1.19 | 1.48 | 5.09 |
| Maryborough | 3.49 | 5.81 | 5.62 | 8.07 | 11.40 | 2.52 | 1.05 | 0.46 | 0.81 | 1.98 | 1.05 | 1.84 | 1.92 |
| Roma | 3.70 | 2.51 | 0.04 | 6.38 | 2.51 | 0.22 | Nil | 0.55 | 0.63 | 1.33 | 1.12 | 2.15 | 2.79 |
| Roma State Farm | ... | ... | ... | ... | ... | ... | ... | ... | 1.27 | 0.73 | ... | ... | ... |
| Tewantin | 3.12 | 7.36 | 10.42 | 12.47 | 14.39 | 7.59 | 8.66 | 0.75 | 1.97 | 2.70 | 2.18 | 2.30 | 7.50 |
| Warwick | 3.25 | 3.13 | 0.76 | 4.52 | 6.65 | 1.40 | 0.15 | 0.80 | 1.24 | 2.99 | 1.96 | 0.96 | 5.28 |
| Westbrook State Farm | 4.76 | 3.23 | 0.43 | 8.03 | 1.41 | 1.40 | 00.5 | ... | 0.49 | 1.97 | ... | ... | 2.05 |
| Yandina | 2.87 | 3.05 | 8.37 | 14.47 | 16.62 | 5.45 | 4.59 | 0.58 | 2.64 | 2.18 | 1.50 | 3.10 | 6.03 |

NOTE.—The rainfall data in this table are compiled from telegraphic reports, and must be considered as approximate only.

GEORGE G. BOND,
Divisional Officer.

Apiculture.

BEE NOTES.

Mr. G. Butler, hon. sec. Queensland Beekeepers' Association, forwards the following bee notes:—

“ Travelling through the Kilcoy district recently, Mr. D. Jones, president of the Queensland Beekeepers' Association, had several inquiries from bee-masters as to the condition of the industry, and particularly in reference to the activity of the Beekeepers' Association. The president was able to impart such information as the questioners sought, and enlist further interest in the objects of the association. The subject of requeening colonies was a prominent topic, and the opinion was freely expressed that a periodical introduction of new strains of queen bees would, to a great extent, by added vigour to the hive, generally compensate for lack of blossoms. Discussing the season's work with Mr. Horne, one of the oldest established beemen in the Woodford district, satisfaction was expressed at a return of 800 lb. of high-class honey from twelve hives. This, in view of the adverse seasonal conditions, may be regarded as a very good return. Mr. Jones informs me also that in the Kilcoy district the forest trees have been badly affected, as before reported of other places, by the caterpillar pest. The ravages of these insects will, it is hoped, be only an occasional attack, as otherwise not only will apiarian interests be adversely affected but our timber supplies, particularly hardwood, will be a diminishing quantity. In some instances the trees die outright as the result of the leaf denudation; others recover, but seem to be a long time regaining their vigour. This, of course, results in meagre bee-food in localities thus ravaged.”

DEMONSTRATION FARMS IN THE UNITED STATES.

During the past few years, says the “ Journal of the Board of Agriculture,” London, an important scheme of demonstration work has been conducted by the United States Department of Agriculture, with the object of showing by numerous practical examples over a large area the advantages of improved methods of agriculture. The work was started in consequence of the deprivations of the Mexican cotton-boll weevil, which threatened the entire destruction of the cotton crop in many districts. Since 1904, a grant of £15,500 has been made annually by Congress, and this was supplemented in 1907 by a grant from the General Education Board of £13,800, so that together, with some local contributions, a sum of about £33,500 was available in 1907-8. Agents have been appointed throughout Texas, southern Arkansas, Oklahoma, Louisiana, and a portion of Mississippi, and the work is also being carried on to a more limited extent in Alabama, Virginia, Carolina, and Georgia. Altogether 143 agents are employed, and with this force about 12,000 demonstration farms had been established and, in addition, 20,000 farmers had agreed to co-operate and make reports on results. The term “ demonstration farm ” is used to designate a portion of land on a farm that is worked strictly according to instructions. This is visited by an agent once a month, to see that these instructions are carried out, and to give further advice if necessary. The farmers who work in co-operation also agree to cultivate their crops according to instructions, but are not visited regularly by the agents.

Tropical Industries.

THE "PULQUE MAGUEY" OF MEXICO.

Under the title "The Century Plant and some other Plants of the Dry Country," Professor William Trelease, of the Missouri Botanic Gardens, contributed a highly interesting paper to the "Popular Science Monthly" of March, 1907, dealing with the various agaves found in Mexico and their characteristics and uses. This paper includes a lengthy account of *Agave atrovirens*, or the "pulque maguey," from which the national alcoholic drink of Mexico is produced. The details given below as to the methods followed in the manufacture of pulque, and the extent of the trade in this product, are extracted from Dr. Trelease's article:—

South of the city of Mexico, centreing about the little town of Apam, the species of agave is almost exclusively the dark-green giant *A. atrovirens*, though, as with extensively cultivated plants elsewhere, it is grown in numerous horticultural varieties which look much alike to the botanist but are distinguished by the planter. Over thirty such forms are said to be planted in the plains of Apam.

As one passes to the colder regions of the north or descends from the tableland into the hot country, still other and different looking species of the same type replace *A. atrovirens*, which, however, far outnumbers and surpasses them all in its aggregate importance. These plantations of *A. atrovirens* are the basis of the pulque industry of Mexico—at once a large item in its agricultural wealth and one of the greatest curses of its labouring population.

The present traffic in pulque is large. Something over 5,000,000 barrels of it are used in the Mexican republic every year, of which quantity about half is consumed in the capital city, and much of the remainder in Puebla and the other large cities of the central plateau. Cheap as it is (for it sells for from 1 to 3 cents of Mexican money for a large glass), its aggregate value amounts to several million dollars per year. Special trains are run into the city of Mexico every morning for its delivery, as is done with the milk supply of American cities. In the Apam district, the plantations are chiefly found on the large haciendas or estates.

The "pulque maguey" is a large plant, and its rosette of thick leaves, though appearing to lie next the ground, is really spaced along a stout trunk as large as a small barrel. The whole, charged with sap, weighs several tons. If left to itself, as it is in gardens on the Riviera, where it is called *A. salmiana*, like the century plant *Agave americana*, it produces a gigantic scape, topped with a candelabrum of flowers, when somewhere in the neighbourhood of fifteen years old. This is never permitted on the large plantations, for the plant possesses its maximum value when it has reached vegetative maturity and the scape is about to develop. At the critical moment, known from the appearance of the central bud, this is cut out, and a shallow cavity is made in the crown of the trunk, which is covered by a stone, pieces of maguey leaves, or other protection. Into the cavity so formed the sap exudes.

It is removed two or three times a day, the surface being scraped and the cavity slightly enlarged each time, until at last nothing but a thin shell of the trunk remains, the leaves meantime having given up their content of fluid and dried to their hard framework—as happens naturally during the flowering period of all the larger agaves, when the reserve of sap is drawn into the rapidly growing scape and flowers.

For a period of three months or more a good plant yields a gallon or two of sap daily, and its total value may be not far from 10 dollars on an average, from which it will be seen that a large maguey plantation represents a considerable item in the assets of a landed proprietor of the plains of Apam.

The fluid which collects in the hollowed trunk of a cut maguey plant, and is gathered in the manner described, is called "agua miel," or honey-water, because of its sweetness; 9 or 10 per cent. of its weight is sugar, and this furnishes the basis for the alcoholic fermentation which is the chief factor in its conversion into pulque. The "agua miel" of the Apam district is thin, clear, and colourless, and possesses a rather pleasant taste.

The fermentation practices in pulque making are still mostly primitive. I have had a Mexican gentleman tell me that, although when the agua miel was gathered and fermented with due cleanliness he considered it a delicious drink, he would not think of touching pulque as offered, for instance, at the railway station at Apam. The vats used in the fermentation are of ox-hide stretched on frames, and they are usually 3 or 4 ft. wide, and nearly as deep. Fermentation is begun by the introduction of a starter or "mother of pulque," obtained by preliminary fermentation, and is carried on either without, or at most with little, artificial control of temperature, and under conditions of positive or negative cleanliness which differ with the various haciendas.

When marketed, the pulque is a white, decidedly viscous fluid containing about 8 per cent. of alcohol; fermentation has not been solely alcoholic, however, and its flavour is in part due to changes wrought by bacteria of several kinds which are introduced with the starter in company with the yeast. Continuation of the action of these collateral ferments causes the beverage to spoil in a day or two under ordinary conditions.

Where the maguey, though capable of cultivation, yields a lesser or inferior product, agua miel is often more appreciated in its unfermented state. As hawked around the streets of Monterey, for instance, in porous earthenware receptacles, it is a cool, yellowish fluid, that is very refreshing on a hot day, and the limpid, yellowish, cidery, foamy product of its fermentation in the north is frequently more to the taste of the foreigner than the white, viscous, odoriferous pulque of the Apam district—which alone pleases the adept.

Considerable medicinal virtue has been claimed for pulque, and some efforts have been made to specially prepare, bottle, and pasteurise it for medicinal or even table use; but, except in the region of its production, where it is the common beverage, the bulk of it is used as an intoxicant, pure and simple. From it is also produced a rather small quantity of distilled liquor—"mezcal de pulque."

Mezcal is a term applied comprehensively to the liquor obtained by distillation from the fermented juices of agaves. Four or five million gallons of it a year are produced, and its value may amount to some 2,000,000 dollars. The centre for the manufacture of this beverage is to the west of Guadalajara, and the town of Tequila, situated there, has given its name to the higher grade of liquor, which is clear, smoky, rather smooth, and with a characteristic essential flavour; it usually contains 40 or 50 per cent. of alcohol, and, like pulque, possesses certain medicinal properties.

Mezcal is sold cheaply. It is to be found everywhere, and contributes largely to the demoralisation of the native labourers, who often drink it to excess.

To supply the distilleries at Tequila, a considerable acreage is planted to mezcal agaves. Those chiefly used for the purpose belong to a well-marked, narrow-leaved species, which a few years ago received the appropriate and distinctive name *A. tequilana*.

BRITISH NEW GUINEA AS A PLANTING COUNTRY.

We ("Tropical Agriculturist," Ceylon) direct attention to the admirable series of "Notes" with which Mr. Wallace R. Westland (son of the well-known Ceylon veteran, Mr. James Westland) has favoured us for publication. Mr. W. R. Westland has been long enough a planting pioneer on the Papuan coast to enable his information to be regarded as both trustworthy and most useful to

any capitalist looking for "fresh fields and pastures new" in the direction of New Guinea. He details the drawbacks very faithfully; but he is equally clear as to the attractions and advantages. Cheap land, finest soil, good climate, and a considerate Government are bound to tell; while the drawbacks which circle chiefly round the labour and absence of roads, &c., may be gradually modified and improved. Meantime, let each one interested study Mr. Westland's very full and interesting notes.

PLANTING IN NEW GUINEA.

BY AN EX-CYLON PLANTER.

Kanosia, Mann Mann, Papua, 2nd August.

The following notes on this island may be of interest to you and others in Ceylon who are on the lookout for rivals to the rubber-planting industry. It must be understood, however, that the views set forth are purely personal, and may require modification as fuller knowledge and more experience are acquired.

To begin with, Papua is reached from Ceylon *viâ* Singapore and Thursday Island, or by way of Sydney to Brisbane, where there is a choice of routes—by the Solomon Islands to Samorai and Port Moresby or to Cooktown—thence to the two ports named.

The latter is the better route, Port Moresby being opposite to and about forty-eight hours' steam from Cooktown. The passage either way is made in comfortable boats, fitted with electric light, refrigerator, &c.

The island, or rather British New Guinea, is flat on the coast, rising rapidly inland range upon range to the main chain of mountains, the highest peaks of which are a great many miles from the sea and 13,000 ft. above it. This gives the visitor every temperature from the sharp frosty air of Mount Victoria to the steamy heat of Samorai, and ensures a heavy and well distributed rainfall. Indeed, some of these ranges must rival the famous Dolosbage, where a week's dry weather elicits a despairing wail from your correspondent about the "awful drought."

The island appears to have two regular monsoons—south-east and north-west—the former being comparatively dry and the latter wet. No severe gales have been known for years and but few trifling earthquakes.

The means of communication between ports are small mail steamers and a number of sailing vessels of all descriptions from about 60 tons downward. Places inland are very much worse off, there being no roads. A few bridle paths (perhaps 50 miles in all) have been cut, but a properly made and graded cart road does not exist. The villages are connected by the ordinary jungle track, quite impassable for horses and often very difficult for laden men. The only means of getting any distance inland is, therefore, by river, of which there are many beautiful ones, most of them navigable for whaleboats for great distances, some of them allowing the passage of small steamers three days' steam up their course.

The east coast—from Samorai to Port Moresby—has the advantage of a barrier reef; inside it small boats can run up and down in comparative safety. So much from the tourist's point of view; now for the planter's.

The soil varies considerably, from the fat black sandy loam in the river valleys and the rich red basaltic soil of the low foot hills, where rank vegetation and heavy crops prove its fertility, to the poor wind-blown sandy coral ridges where stunted grass fights seadrift for a living.

The deep valleys in the mountain ranges must contain some magnificent soil, far richer than anything we can produce in Ceylon, to judge by the deposits and colours of the rivers in spate. All the old explorers are agreed that this island contains some of the most fertile soil in the world.

The land is assumed to belong to the natives, and is purchased at low rates from them by Government from time to time as opportunity occurs. In some cases, owing to the Survey Department being greatly undermanned and the absence of a trained land buyer, huge blocks were bought in a most perfunctory way—the areas and boundaries being indefinite to the last degree. This has now ceased, and drastic changes have occurred in these departments.

The intending planter may now select and apply for any block of land, depositing with his application a small fee, proportionate to the area required.

If the land applied for already belongs to Government, and if he satisfies them that his intentions are *bonâ fide*, the land is usually granted at once, and he is free to commence operations forthwith.

Should the block belong to natives, the A.G.A. of the district is instructed to endeavour to purchase it from them. If he succeeds, the procedure is as above; if not, the applicant is informed of the fact, and invited to select another block somewhere else. No direct purchase between planter and native is permitted.

The land is granted as leasehold for 99 years on most liberal terms, there being no survey fee and no rent for ten years; after which 6d. (maximum) per acre becomes due annually. One-fifth of the area suitable for cultivation has to be under cultivation five years from date of grant.

The areas at present taken up are mostly for cocoanut and rubber planting along the coast. There are several small estates inland in coffee, and more land is being applied for in their neighbourhood. A new industry is commencing in sisal hemp, some large blocks having been secured recently and a start actually made.

One great factor in all tropical agriculture is labour; that of British New Guinea is one of the most interesting problems any country can present.

The labour here is the native Papuan in an extraordinary diversity of type, language, and disposition.

The native from the eastern and central divisions of coastal districts is, as a rule, a light-hearted cheerful man, ready to laugh or sing all day long, and make light of a task. If well-fed and looked after, he is as ready to raise a cheer and a yell at the end of his day's work as at the commencement. Some men have a bad reputation, and it is not wise to trust them too much yet, but their main failing is that there is not more of them! The Mawata and Kiwai district men in the west are more pearl divers and boats' crews than coolies, although a few are found here and there along the coast. The Gulf district, which is said to teem with natives, and is the only district where they may be said to be in thousands, gives the worst class of labour. They are greedy, sulky brutes, without any idea of steady work. They cannot count beyond five, have very little intelligence, and are only fit for pack-carriers. The miners in the eastern districts will have none of them, except as porters. They are in every way quite unsuited for estate labour.

The remaining class, the bushman, is as wild as a hawk, and cannot, for a long time yet, be depended on for anything but spasmodic labour. At present he is usually too scared to approach at all, and as often as not bolts out of the village on the first alarm. Once tamed, they are said to be excellent. The estate labour is indentured; on the whole, the laws may slightly favour the native. A man is signed on for any period up to three years. At the end of that time the employer has to return him to his home—free. Contract can be broken by mutual agreement; or, in the event of the employer wishing to rid himself of the man, the latter can demand his wages for the full period. Conversely, if the man bolts, the employer can imprison him, and add the term of imprisonment on to his term of service.

No native women have signed on as estate coolies yet, owing doubtless to the tales their men-folk have spread on their return from mining camps or carrying tracks. These occupations have been the most important hitherto,

and are not ones which would appeal to women. It is hoped that by establishing villages on the estates, giving each married man a little hut to himself and keeping each little tribe together, the native will not want to leave the estate when his contract of service expires, but settle down for good. Do not we all know the coolie who has been man and boy on the same estate all his life? Estate work is practically unknown in British New Guinea, and *festina lente* the best motto to write across the muster roll.

As to cost: The recruiter charges, say, £2 10s. per head landed on the estate, 3s. Government fees, signing on and off, &c., and 10s. return passage; so that each indentured native costs £3 3s. For a three-years-agreement-man the rate is £6 2s., all of it irrecoverable. Kit has to be supplied from motives of policy to keep the man in health—blanket, mosquito net, plate, pannikin, spoon, billy can, cooking pot, jumper, and waist cloth. Food is a much-vexed point. By the Government regulations the employer is required to supply him with good and sufficient food. Rice is now £15 to £17 per ton at Port Moresby (transport inland extra). Sago flour, an excellent food, £6 10s., when obtainable. It may be had at times, but only in small quantity and irregularly. Of sweet potatoes, yams, taro, &c., no large supply is available, and it is doubtful whether the cost of cultivation and harvesting balance the saving of time and labour in giving imported foods.

Chillies, curyrustuffs, and the "selavu," so dear to Ramasamy, are unknown here.

Wages are 10s. per month, wet or fine, sick or sorry, and no Sunday work. They are due at the end of term of service, and must be paid before a native labour officer. An advance may be given from time to time, but the practice is discouraged, as the native has then nothing to take back to his village.

All these things combined make labour work out at not less than 1s. per working day at a low estimate.

All skilled labour is at present white, and cost £12 to £19 per month for carpenters, boatbuilders, &c. Coloured foremen may be imported at the discretion of the Government, and are granted a certificate for a term of years, which must always be specified. At the end of their term they have to leave the country under penalty of £50 fine.

The present rate of wages for black and white labour is absurdly high all round. Fancy a new country, endeavouring to attract capital, hanging this millstone around the capitalist's neck. When competition or skill enhances the value of the labour, let wages rise by all means, but why start from this pinnacle—the highest in sight?

This can never be a satisfactory white man's country—*i.e.*, a country where he can do manual work alongside of and retain the respect of his black helpers.

The natural market for the produce of British New Guinea is, of course, Australia; but as yet the Customs in that protectionist country do not favour markedly its first-born colony.

If the Commonwealth insist on framing laws which keep alien labour out of this country, and thus raising cost of production, it is only reasonable to hope that it will allow that country some concession which will enable it to compete successfully with other countries where such handicaps do not exist. At present, when New Guinea produce—say, maize—is mentioned in Australia, the cry is, "Grown with black labour," and its doom is sealed.

There are many products, coffee, cacao, cocoanuts, rubber, to mention a few which do not appear to be extensively cultivated in Australia. These would grow to perfection here. Why not make this Australia's tropical garden, where such products as require a large number of labourers per acre could grow, enter the Commonwealth free of duty, and compete with other countries whose produce pays a heavy tax?

The cost of living, if luxuries are eschewed, is not high. Fresh vegetables can be had if sufficient energy be put into gardening in suitable soil. In the

central division, at sea-level there are gardens, where beans, carrots, turnips, beetroot, &c., grow well; while on the hills, limes, oranges, papayas, &c., come to perfection.

Most people have "no time," or don't care, and prefer to struggle along with tinned apologies for these necessaries. If one or two good Chinamen were allowed to start a market garden, they would make a great difference to those near them.

Fowls are practically unknown, and fresh beef one hears of but seldom sees. Good mutton is sometimes to be had in port, but more often than not the tinned delicacy known as "Bullemakow" is the *pièce de resistance*.

Society away from towns—nil. The natives have taken to cricket; and the astonishing spectacle of a frizzy-haired Papuan, clothed in a string, wicket-keeping as if to the manor born, is one that may be seen in almost every large coastal village.

Sport: For the sportsman there are strange and beautiful fish on the reefs where you look over the side into 20 ft. of water to see the bottom as clearly as if a yard away. In the estuaries the white Torres Strait pigeon roosts on the mangroves, and gives the most sporting of hard chances; or in the bush, where the pigeons and doves call all day long, one may shoot a tiny dove the size of a bulbul or a fat-crested goura, weighing 10 or 12 lb., and tasting better than the best turkey. Pigs roam the country, but are as shy and hard to find as deer. Those here are much smaller than the Ceylon pig, but seem as fierce and cunning when cornered as the biggest grim grey boar. Wallabies of sorts swarm in every acre of the low country, while one occasionally sees the track of some big cassowary or hears his sonorous call.

These notes are sketchy and incomplete, and have the additional disadvantage that they are from the writer's point of view—necessarily a limited horizon; but the ideas embodied are the result of much earnest discussion with those whose long residence in and knowledge of the country entitle them to speak with authority. The drawbacks to the intending planting investor of capital are:—

A Survey Department very much undermanned, and consequently in arrears of work. This means doubtful boundaries until block surveys are completed.

Unsettled labour laws, which means that the available labour is an unknown quantity. High wages for all labour, and high rates for goods to and from the country. Absence of roads, portending difficulties of land transport. Insufficient postal arrangements and a market of which the hospitality is, to say the best of it, doubtful. Conversely, the attractions, and they are not small, are a title to land which is indisputable; generous land laws; the finest soil that heart could wish for, growing magnificent timber. Soil that will grow any tropical product he takes the trouble to cultivate, every variety of climate, and as healthy a new country as one can hear of. With ordinary care and temperate living, his health here will be as safe as in any other rubber-growing part of the tropics.

One thing the intending planter can be sure of, the cordial assistance of every member of the Government. From His Excellency the Administrator down to the last-joined cadet every officer appears to look upon the planter as his especial *protégé*, and no service, no inconvenience, no discomfort is too great if by that means he can forward the planting industry in the slightest degree.

I take this opportunity of offering my most grateful thanks to those officers for their many acts of kindness and courtesy, and to assure them that but for their assistance my task would be a very different one and not the pleasure it is.

[Mr. Westland is managing director of the Papua Rubber Plantation Company in Papua. We have purposely omitted some of his remarks on coloured *v.* white labour.—Ed. "Q.A.J."]

COCOA-NUT PLANTING IN SAMOA.

Copra forms by far the most important article of export from the Samoan Islands at present, says the "Agricultural News" of Barbadoes, although the shipments of 1907 (5,400 tons, valued at £77,981) fell far below those of the previous year. The price of the product, too, fell from £17 per ton in 1906 to £12 in 1907. Notwithstanding this, the British Consul at Samoa states that owners of land suitable for cocoa-nut cultivation are paying increasing attention to the industry, and the Government of the islands have for some years past required that each Samoan family shall plant at least fifty cocoa-nuts yearly on their land.

The following notes are taken from the latest report of the British Consul at Samoa:—

It is recommended that the holes in which the cocoa-nuts are to be planted should be about 2 ft. deep and correspondingly wide, and that they should be filled with a mixture of good soil and compost, ashes, a little salt, and, in cases where the soil lacks lime, some coral sand. The nuts should be covered with at least 3 or 4 in. of soil, and not be closer together than 33 ft., or about forty to the acre, or in the immediate neighbourhood of the sea they may be 30 ft. apart.

The crucial point is for the trees to have light and air on all sides, otherwise they will not bear well. Where forest trees are left standing in their neighbourhood, the growth of the cocoa-nut palms is much retarded and the yield lessened; and when even orange and other fruit trees overgrow and overshadow them, they do not thrive. According to the experience of some planters, trees growing 1 or 2 miles from the sea have a much smaller yield than those growing close to it, although this may not everywhere be the case.

It is stated by the authority mentioned above that the upward growth of the cocoa-nut palm in Samoa appears to be slower than in the coral islands of the South Seas, and especially New Guinea. But in place of this it appears to attain a greater age in Samoa, with unaltered yield. I was shown palms by one of the oldest planters in Samoa, which were still in full bearing, although they were reputed to be eighty years old. Such trees may certainly attain an age of a hundred years. The crowns of the palms in Samoa appear to me to be richer in leaves and much more compact than those of several parts of Kaiser Wilhelmsland.

The full-grown cocoa-nut plant is a bad neighbour to other plants, as its root system is uncommonly strong.

THE CANDLE-NUT TREE.

The Candle-nut Tree (*Aleurites triloba*) forms the subject of a paper in the "Agricultural Ledger of India," No. 4, 1907. This tree, which belongs to the natural order Euphorbiaceae, is not uncommon in the West Indies, and in Jamaica it is known as the "Country Walnut." The countries in which it is found growing in largest quantity, however, are Java, Sumatra, the Moluccas, and South Pacific Islands. It has also been naturalised in many parts of India and in Madagascar.

The fruit of the candle-nut tree is about the size of a small orange, and usually contains two heart-shaped seeds enclosed within hard shells. The seeds are interesting on account of the fact that they contain about 60 to 66 per cent. of a useful oil, which has a considerable market value. The candle-nut has received its name from the fact that the kernel burns like a candle when a light is applied to it, and in the South Pacific Islands the kernels are threaded on reeds and used as torches.

Of the 60 per cent. of oil contained in the seeds, about 55 per cent. is capable of being readily extracted on a commercial scale. This proportion is very high when compared with other oil-bearing seeds and nuts. Castor-oil beans yield no more than 40 to 45 per cent. of oil. The oil expressed from the nuts is known as Bankul oil or artists' oil. It is a drying oil, and is used in the arts for the same purpose as linseed oil—viz., in the manufacture of oil-colours, lacquers, and varnishes, and also for soap-making. The cake from which the oil has been expressed may be used as a cattle food or a manure.

Samples of candle-nuts have been submitted to brokers in London, who stated that the kernels should meet with a ready sale at £12 to £13 per ton.—“Agricultural News of Barbadoes.”

[The Candle-nut Tree has also been successfully acclimatised in Queensland.—Ed. “Q.A.J.”]

Times of Sunrise and Sunset at Brisbane, 1909.

| DATE. | JANUARY. | | FEBRUARY. | | MARCH. | | APRIL. | | PHASES OF THE MOON.
H. M. |
|-------|----------|-------|-----------|-------|--------|-------|--------|-------|------------------------------|
| | Rises. | Sets. | Rises. | Sets. | Rises. | Sets. | Rises. | Sets. | |
| 1 | 4:57 | 6:46 | 5:21 | 6:42 | 5:40 | 6:20 | 5:57 | 5:46 | 7 Jan. ○ Full Moon 0 13 a.m. |
| 2 | 4:57 | 6:46 | 5:22 | 6:41 | 5:41 | 6:19 | 5:58 | 5:45 | 15 „ ☾ Last Quarter 4 11 „ |
| 3 | 4:58 | 6:46 | 5:22 | 6:41 | 5:42 | 6:18 | 5:58 | 5:44 | 22 „ ● New Moon 10 12 „ |
| 4 | 4:59 | 6:46 | 5:23 | 6:40 | 5:42 | 6:17 | 5:59 | 5:43 | 29 „ ☽ First Quarter 1 7 „ |
| 5 | 4:59 | 6:46 | 5:24 | 6:40 | 5:43 | 6:16 | 5:59 | 5:42 | |
| 6 | 5:0 | 6:47 | 5:25 | 6:39 | 5:44 | 6:15 | 6:0 | 5:41 | |
| 7 | 5:1 | 6:47 | 5:25 | 6:38 | 5:44 | 6:14 | 6:0 | 5:40 | |
| 8 | 5:2 | 6:47 | 5:26 | 6:38 | 5:45 | 6:13 | 6:1 | 5:39 | |
| 9 | 5:2 | 6:47 | 5:27 | 6:37 | 5:45 | 6:12 | 6:1 | 5:38 | 5 Feb. ○ Full Moon 6 25 p.m. |
| 10 | 5:3 | 6:47 | 5:28 | 6:36 | 5:46 | 6:11 | 6:2 | 5:37 | 13 „ ☾ Last Quarter 10 47 „ |
| 11 | 5:4 | 6:47 | 5:28 | 6:36 | 5:46 | 6:10 | 6:2 | 5:35 | 20 „ ● New Moon 8 52 „ |
| 12 | 5:5 | 6:47 | 5:29 | 6:35 | 5:47 | 6:9 | 6:3 | 5:34 | 27 „ ☽ First Quarter 0 49 „ |
| 13 | 5:5 | 6:47 | 5:30 | 6:34 | 5:48 | 6:7 | 6:3 | 5:33 | |
| 14 | 5:6 | 6:47 | 5:30 | 6:33 | 5:48 | 6:6 | 6:4 | 5:32 | |
| 15 | 5:7 | 6:47 | 5:31 | 6:33 | 5:49 | 6:5 | 6:4 | 5:31 | |
| 16 | 5:8 | 6:47 | 5:32 | 6:32 | 5:49 | 6:4 | 6:5 | 5:30 | 7 Mar. ○ Full Moon 0 56 p.m. |
| 17 | 5:9 | 6:47 | 5:33 | 6:31 | 5:50 | 6:3 | 6:6 | 5:29 | 15 „ ☾ Last Quarter 1 42 „ |
| 18 | 5:9 | 6:47 | 5:33 | 6:30 | 5:50 | 6:2 | 6:6 | 5:29 | 22 „ ● New Moon 6 11 a.m. |
| 19 | 5:10 | 6:46 | 5:34 | 6:29 | 5:51 | 6:1 | 6:7 | 5:28 | 29 „ ☽ First Quarter 2 49 „ |
| 20 | 5:11 | 6:46 | 5:35 | 6:28 | 5:51 | 6:0 | 6:7 | 5:27 | |
| 21 | 5:12 | 6:46 | 5:35 | 6:28 | 5:52 | 5:59 | 6:8 | 5:26 | |
| 22 | 5:12 | 6:46 | 5:36 | 6:27 | 5:52 | 5:57 | 6:8 | 5:25 | |
| 23 | 5:13 | 6:46 | 5:37 | 6:26 | 5:53 | 5:56 | 6:9 | 5:24 | |
| 24 | 5:14 | 6:45 | 5:37 | 6:25 | 5:53 | 5:55 | 6:9 | 5:23 | 6 Apr. ☽ Full Moon 6 28 a.m. |
| 25 | 5:15 | 6:45 | 5:38 | 6:24 | 5:54 | 5:54 | 6:10 | 5:22 | 14 „ ☾ Last Quarter 0 30 „ |
| 26 | 5:16 | 6:45 | 5:38 | 6:23 | 5:54 | 5:53 | 6:10 | 5:21 | 20 „ ● New Moon 2 51 p.m. |
| 27 | 5:17 | 6:44 | 5:39 | 6:22 | 5:55 | 5:52 | 6:11 | 5:20 | 27 „ ☽ First Quarter 6 36 „ |
| 28 | 5:17 | 6:44 | 5:40 | 6:21 | 5:55 | 5:51 | 6:12 | 5:19 | |
| 29 | 5:18 | 6:43 | ... | ... | 5:56 | 5:50 | 6:12 | 5:18 | |
| 30 | 5:19 | 6:43 | ... | ... | 5:56 | 5:48 | 6:13 | 5:17 | |
| 31 | 5:20 | 6:42 | ... | ... | 5:57 | 5:47 | ... | ... | |

Entomology.

DESTRUCTION OF THE PUMPKIN BEETLE.

Mr. H. Tryon, Entomologist and Vegetable Pathologist, has suggested the following measures for the suppression of the "pumpkin beetle" (*Aulacaphora punctata*):—

Treat the potatoes and pumpkins, &c., with Paris green, applied in the form of a fine spray, and not exceeding 1 lb. to 160 gallons of water. It must, of course, always be kept well stirred while in use, and should not be applied during rain, sunshine, or heavy drying winds; or to either fruit or vegetables within a month of the time of gathering.

Another good spray is made of white arsenic and lime in the following proportions:—White arsenic, 1 lb.; slacked lime, 2 lb.; water, 3 gallons.

Slowly slack the lime, add the arsenic, put in the water, and boil for an hour. Add 160 gallons of water, and it is ready for use. Be careful to boil the mixture thoroughly, and if the lime is not of good quality increase the quantity.

I should advise, where practicable, the destruction of the beetles by shaking them into a bucket or pan containing a little kerosene or boiling water. Where they are feeding in great numbers, this would be a simple way of destroying considerable quantities, and be taking advantage of the habit this species has of feeding in company and suddenly dropping off the leaves when alarmed.

INSECTS DESTRUCTIVE TO GRAIN IN BIN AND GRANARY.

The Assistant Entomologist of the Kansas, U.S.A., Experimental Station has issued a useful bulletin on "Insects Attacking Grain in the Stack, Bin, and Granary." He says:—

Of the twelve or thirteen species of beetles attacking stored grains, not more than five or six are commonly found at work in the farmers' bins. To these may be added four species of small moths, of which the Angoumois grain moth is the most serious pest attacking ripened corn, and the meal moth and the Mediterranean flour moth the serious ones in meal, bran, or any of the ground grain products. The farmer applies the term "weevil" to all of these insects, and distinguishes the moths by the term "fly weevil." All are of small size, none of the beetles exceeding $\frac{5}{8}$ -in., and the most of them being less than $\frac{1}{4}$ -in. long, reddish, black, or brown in colour. The moths are tiny "millers," and their work in the bins and granaries may be distinguished from that of the beetles by the presence of web or silk in the grain, bran, meal, or flour.

METHODS OF CONTROL.

Measures to be employed in the control of this class of insects are both preventive and insecticidal.

PREVENTIVE.—To avoid infestation in the stack, the grain should be threshed as soon after harvesting as practicable. Fresh grain should not be exposed to attack by being placed in bins or granaries with that already infested. Before storing, the old grain should be removed and the floors, walls, and ceilings of the bins thoroughly cleaned. If the granary has been badly infested, it should be fumigated. Cleanliness is very important in preventing

injury by these insects. Dust, dirt, rubbish, refuse grain, flour, and meal serve as breeding places. Frequent agitation or handling of the grain will destroy many of these moths, because they are unable to free themselves from a mass of it, and perish in the attempt.

INSECTICIDAL.—Fortunately, it matters little what species may be causing the trouble, for all succumb to the same treatment. The simplest, most effective, and inexpensive remedy for all insects infesting the farmers' grain stored in tight bins is careful fumigation with carbon bisulphide.

The Amount of Liquid to be Used.—This depends upon the size of the buildings, on its tightness, and the nature of the attack. If the building is reasonably tight and the infestation slight, 1 lb. of carbon bisulphide is sufficient for every 700 cu. ft. of space, or 1 lb. for every 100 bushels of grain. In case the building or bins are not sufficiently tight to allow thorough fumigation, the amount of the liquid should be doubled or even tripled. If the insects are beetles, and are very abundant, the liquid should in every case be doubled.

Preparation.—The building and bins must be made as nearly air-tight as possible, in order that the vapour may remain in all parts of the space in full strength and for the required time. The vapour must enter all cracks and crevices by diffusion. The doors and windows should be arranged so they can be opened from the outside when fumigation is completed. Care should be taken to have everything ready and in its place, so that after the first vessel has received its liquid it will be unnecessary to stop to adjust anything. Everything should be done to avoid unnecessary delays and to facilitate the rapid evaporation of the liquid.

Placing the Liquid.—The liquid should be placed in shallow pans or dishes as high as possible in the bins or building, since the vapour is heavier than air, and settles to the lower parts. It should be well distributed, having not more than a half-pound in a place. In large bins, to hasten and equalise the operation, it is well to put a quantity of the liquid in the centre of the grain by thrusting into it a gas pipe, loosely plugged at one end, down which the carbon bisulphide may be poured and the plug loosened with a rod. The liquid may be applied directly in this manner to infested grains or seeds without injuring their edible or germinative qualities.

If a building of more than one floor is to be fumigated, the operator should begin on the first floor and work upward, and after placing the liquid in the second story leave the building through a window that he can close after him. If impossible to get out from the upper story, the carbon bisulphide should first be distributed there, working downward as rapidly as possible to avoid the settling vapour.

Length of Exposure.—The bins or building should be allowed to fumigate from 24 to 36 hours. The best plan usually is to apply the liquid on a Saturday afternoon, and leave the building closed until the following Monday.

Ventilation.—Doors and windows should be opened wide and the building or bins aired thoroughly one or two hours before entering. Slight traces of the odour will linger in corners and other places where the air does not move freely, but these will gradually disappear.

Precaution.—The vapour of this liquid is highly inflammable and explosive. No fire or light of any sort should be allowed about the building while the fumigation is in progress. The application should always be made in daylight, for artificial light of any kind is dangerous. Electric lights must not be used, since when turning them on or off there is always danger of producing a spark. Nor is it safe to have heat of any kind in the building while the fumigation is in progress.

General Notes.

ANOTHER DROUGHT PREDICTED.

Mr. Clement Wragge, who, while Government Meteorologist in this State, achieved a reputation for his accurate weather forecasts, and although at present on a lecturing tour in India, does not forget his old friends in Queensland, but occasionally gives them a friendly warning as to the future seasons. In March, 1906, he wrote to the London "Standard," foretelling another drought, and ended his letter as follows:—

"Now is the time for Australians to wake up and lock the rivers for water conservation and irrigation. Better so than trying to keep out the Japanese. For another Australian drought will attach to the next solar minimum after 1910 as surely as little apples fall in autumn. Laughing and ridicule will never alter fact, and Galileo's spirit will bear full witness."

A few weeks ago he returned to the charge, and has declared that the rainfall in Australia will now fall off, but he gives the comforting assurance that the coming drought will not be so severe as the last.

Will farmers and dairy farmers seriously consider the probability of another recurrence of the drought, which, owing mainly to the neglect to conserve the superabundant fodder of previous fat seasons, entailed such ruinous loss upon the improvident ones? The silo should be in evidence on every farm, and now is the time to prepare for the inevitable. By and by it will be useless to call upon Jupiter for help.

EXTERMINATION OF SPARROWS.

With reference to the sparrow pest, Mr. R. B. Shackleton, Glass Mountains, writes:—

Re SPARROW EXTERMINATION.

I noticed with interest in Journal for November, pp. 254-5, remarks on this subject. You are possibly aware that in England the sparrow pest is becoming very acute, and various schemes for its riddance are being discussed in the "Times" and other papers. I enclose a cutting from "The Keighly News" (Yorkshire), which covers some very sensible remarks, and draws a conclusion which it would be well for us here to reflect upon. I always have held that Nature, if left fairly alone, will restore oft-needed balances.

Our humble friend, the ground cuckoo shrike, is one of Nature's weapons to rid us of what threatens to become a very serious infliction, just as the owl, the kestrel, and hawk tribes in England, if left alone, would do their work right well.

The paragraph from the Yorkshire journal is as follows:—

THE CAMPAIGN AGAINST THE SPARROW.

With the crusade against the rat we are fairly familiar, and most of us are quite ready to agree that there is something to be said for the proposal for diminishing his numbers. But the latest suggestion is to couple the sparrow with him, and to wage unceasing and merciless warfare against both. There has been a long correspondence in the "Times" on the subject, starting with a letter from a certain popular novelist, who told a doleful tale of the havoc wrought in field, garden, and orchard by these pertinacious little thieves, and culminating in a serious proposal for the institution of universal sparrow

clubs, and a demand for Government subsidies if it is found that the Englishman's love of killing something is not sufficient in itself to lead him to shoot sparrows fast enough. Having got thus far, however, those who had put forward this delightful little plan for getting rid of a feathered pest discovered that the sparrow still has a few friends. These, naturally, raised a protest against his wholesale destruction. A still larger number of people began to hint that, unless the knowledge of natural history kept pace with this proposed sharp-shooting practice, there would be a grave danger of our new crack shots indulging in an indiscriminate slaughter of the innocents of the feathered race in their anxiety to keep down the thievish and troublesome sparrow.

As for the more thoughtful members of the community who took the matter into careful consideration, they were not slow to point out the absurdity of trying to restore, by means of gunpowder, that balance of Nature which we have deliberately permitted to be upset. As a writer in the "Nation" says, if it be true that the sparrow has immensely increased in numbers it is not difficult to assign the reason. "England is becoming the playground of the rich, and their pleasures make the gamekeeper the chief arbiter in the survival of species. The gamekeeper has destroyed the owl, the kestrel, and the sparrow-hawk. The consequence is that rats and sparrows multiply." The cheapest and most sensible remedy for the plague of sparrows about which we have been hearing so much of late is not to engage in a universal shooting campaign against these little creatures, but to stop the shooting campaign which has been so long in progress against the hawk, the kestrel, and the owl. Nature will do the rest, and will do it more effectually and intelligently than forty thousand subsidised sparrow clubs could.

SPARROW-DESTROYING BIRD.

In the November issue of the Journal we made reference to a bird which was said to attack and destroy sparrows. Since then a letter has been received by Mr. Thos. Hardy, the well-known South Australian vigneron, from Mr. J. W. Mellor, honorary secretary of the South Australian Ornithological Society, in which he says:—

"Re the notice of bird-destroying sparrows in New South Wales, as per Government Agricultural Gazette. The bird, Ground Cuckoo Shrike (*Pteropodocys phasianella*) is nearly allied to the *graucalus* family, a species of which is common here—viz., the Black-faced Cuckoo Shrike (*Graucalus melanops*), commonly known as the slaty doves, blue doves, &c., on account of the slaty-blue colour predominating in the plumage. The family is chiefly insectivorous, and useful birds in agricultural districts. They will eat berries a little, but not to the extent of doing harm. The nest is shallow, and composed of web and fibres woven together on a horizontal fork of a tall tree. They lay only two eggs, of olive-green colour, spotted with brownish spots; but the ground variety has eggs of more uniform light olive-green colour. Being only two in a clutch, the increase is somewhat limited. The ground cuckoo shrike is found right through the interior of Southern Australia, from New South Wales to South Australia; but we do not see the bird so far south as Adelaide. I am somewhat sceptical as to its 'killing' propensities with the sparrow. It may worry a bit, but that at most. I should like to have more evidence relating to this new departure in its life history before making it a fixed habit. The bird needs to be studied closely in its natural haunts before coming to any conclusion. The birds are naturally migratory. Other species here generally depart during the winter, returning about Christmas time, and are sometimes called Christmas birds on that account. They are totally protected in South Australia. A few stay with us at the Redbeds and breed. I do not know whether the ground variety would go down South, for they have not come down of their own accord, although the way is quite

open to them. Care needs to be exercised in introducing birds, for fear of their attacking our small native birds, in addition to sparrows, and so doing more harm than good. A responsible person should be got to look after their habits before making any step of introduction, &c., and I would advise the collection of data from the districts where the bird breeds, as it is here that the true propensities generally exist."

HOW TO VANQUISH THE MOSQUITO.

An American paper says that a very simple and perfectly effective method of destroying mosquitoes is to make use of permanganate of potash. Two and a-half hours are required for the development of the full-grown mosquito from the larva. It can be instantly killed either in its infancy, or at maturity, by contact with minute quantities of this chemical. A solution of the salt, containing only 1 part in 15,000 of water, distributed in swamps and water-holes where mosquitoes breed, will render the development of the larvæ impossible. A handful of permanganate will oxidise a 10-acre swamp, kill all its embryo insects, and keep it free from organic matter at a cost of 25 cents (12½d.) An efficacious method is to scatter a few crystals wide apart. A single pinch of permanganate has killed all the germs in a 1,000-gallon tank. The above is from "The Public Health Journal," U.S.A.

Some years ago we noticed large numbers of mosquito larvæ in a small waterhole at Nundah. A few months later none were to be found in it, but by some means or other (probably by the help of birds or cattle, carrying fish spawn on their feet), this waterhole became alive with tiny brilliantly-coloured fish, about 2 in. long. Doubtless these little fish destroyed the larvæ. Confirmation of this theory, we now find in an article in the London "Times," republished in the "Journal of the Jamaica Agricultural Society" for September, 1908. It is as follows:—

"It has long been known that Barbados is the only West Indian island that is absolutely free from malaria and from the presence of the anopheles mosquito. Major Hodder, R.E., in his report to the War Office three years ago on the drainage works that were then being carried out in St. Lucia, came to the conclusion that there was some hitherto undiscovered reason why the anopheles failed to propagate its kind in Barbados, where the culex was abundant. It appeared from his observations that the anopheles could, or did, only breed on the ground level; none of its larvæ being found in tanks which were raised a few feet from the earth, nor even in those which were actually resting on the ground. The culex can, on the other hand, breed in the gutters on the roofs of high buildings as easily as in the low-lying swamps and pools. My friend Mr. C. Kenrick Gibbons, who had given a good deal of attention to the matter, pointed out at once that all the pools and swamps in this island were stocked with swarms of a tiny fish (known locally from their vast numbers as 'millions'), and that their favourite food was the larvæ of the mosquito. It is obvious that any species of that insect which is unable to breed above the ground level must fall a prey to this enemy. The fish has been identified by Mr. Boulenger, F.R.S., of the British Museum, as *Girardinus pocciloides*. Some specimens were successfully got to England, and flourished for some time in the insect house at the Zoological Society's Gardens. Mr. Gibbons' suggestion that the 'millions' should be imported into malarial districts in other islands has been acted upon, and with felicitous results. For instance, the Country Health Board of Antigua, 'being convinced of the useful part played by these fish in consuming mosquito larvæ, have arranged for their systematic distribution throughout the ponds and streams of the island.' Similar news comes from Jamaica, whither a consignment of the fish was sent in November, 1906. The secretary of the Agricultural Society writes that the tanks at the Titchfield Hotel are full of them, and that

he had been informed that there had been a marked diminution of fever round about, the 'millions' evidently accounting for the mosquito larvæ. They have also been sent to Colon and to British Guiana. One cannot help wishing that these useful little fish were given a trial in the deadly districts of Africa. Like the malarial mosquito, the insects which convey the terrible diseases which are endemic there pass the larvæ stage of their existence in water. One may add in this connection that the Swedish consul at Frankfort has discovered a small fish ('the blue-eyed') which feeds on mosquito larvæ, and that, at the request of the Italian Government, some are to be, or have been, sent to the Campagna, where so much has been done in recent years to diminish malaria."

To this, the editor of the Jamaica journal above mentioned adds:—

In many of our streams and ponds here, the same little fish called "millions" in Barbados and "ticky-tickies" here are found, and many people have used them in their tanks. The consignment mentioned as having been got from the Barbados was closely examined, and the "millions" found to be identical with our "ticky-tickies." Tanks are very favourite breeding places for mosquitoes, and we are afraid it is only a few who appreciate the necessity of preventing the mosquitoes breeding—for their own comfort and well-being. We are glad to draw the attention of every reader to this fact, that the little "ticky-tickies" live on the larvæ of mosquitoes, and that in districts subject to these insects, and where tanks and ponds are used, this little fish should be put in these. This does not, however, do away with the fact that mosquitoes breed wherever a little stagnant water collects, and care should be taken to prevent this as far as possible, by cleaning these places with kerosene.

The "Tropical Agriculturist," Ceylon, takes the following suggestion from the "Madras C. C. Magazine":—

A trap for catching mosquitoes has been devised by Mr. Maxwell Lefroy which is simple and effective. It consists of a small box, about 12 in. square and 9 in. wide, with hinged lid which has a small orifice with a sliding cover. The box is lined with dark-green baize, and has a tin floor. The trap is placed in a shady corner of the room, and the mosquitoes, when they enter the house in the morning, seclude themselves in it to escape the sunlight. The lid is then shut, and a teaspoonful of benzine injected into the box. Mr. Lefroy found that in a short time the mosquitoes succumbed, and by continuing this process for a month caught and killed over 2,300.

PLANTS IN BEDROOMS.

It is generally believed that it is unhealthy to keep plants and flowers in bedrooms. This may be true, observes the "Mouvement Industriel," in the case of flowers, owing to their perfume, but a green plant, on the contrary, improves the air of a room. Consequently, a living plant increases the amount of vapour necessary for constitution of the air. From the point of view, of health, then, it would be advisable to keep a number of green plants in rooms, especially when heated. In addition to purifying the air by contributing moisture to it, they enliven the view and help the sick to support the *ennui* of confinement.

A CODLIN MOTH PARASITE.

The South Australian "Journal of Agriculture" says that a worm has been discovered which infests the grub or caterpillar of the codlin moth, and which may prove of some service in the battle against that great pest of our apple and pear trees. Mr. A. F. Furniss, of Mount Lofty, when removing the bandage from an apple-tree in his orchard, found that some of the grubs had died before the cocoon was completed. Mr. Quinn, the Horticultural Expert, placed the dry remains of the grub in distilled water, and found inside it two thread-like

worms, which returned to life in the liquid, and one of which measured over 6 in. in length when unwound. Specimens of the worm were sent to Mr. W. W. Froggatt, the Government Entomologist of New South Wales, for identification, and Mr. Quinn, who is attending the Australasian Fruitgrowers' Conference in Melbourne, has taken further specimens to show to the entomologists at that gathering. There seems no doubt that a parasitic worm is destroying some of the hibernating caterpillars of the codlin moth, but its life history and the amount of aid which it can give towards combating the pest are matters for investigation.

A WATER-WEED CUTTER.

Mr. J. Plummer, Lane Cove River, Sydney, sends the following extract and illustration of a new water-weed cutter, taken from the "British Trade Journal." The saw, as it is called, would doubtless do good work in canals, ponds, and streams unencumbered by sunken timber, but we should doubt its efficacy in our streams and waterholes infested by water hyacinth, owing to the number of snags which are found in such places.

The apparatus consists, as the accompanying illustration shows, of a flexible saw, which is weighted at certain points, a few feet apart, by torpedo-shaped sinkers. At each end of the saw is a clamp to which is fastened, by means of a short length of stout wire, a cross handle. The saw is lowered into the water, and then the weed cutting is carried out by two persons, one at each end, who move the saw backward and forward about a yard each way. The teeth of the saw work against the stems of the weeds, which as they are severed float away. The saw can be had in two grades—the stout, $\frac{5}{16}$ in. wide, and the ordinary, $\frac{1}{4}$ -in. wide. Ten yards of the stout saw weigh 10 oz., and the whole apparatus, complete with four sinkers and the two end clamps and wire attachments, weighs under 10 lb., and costs a comparative trifle. The apparatus is extremely simple, and very little labour and no skill are necessary to work it. As the saw itself is flexible, it accommodates itself to any height

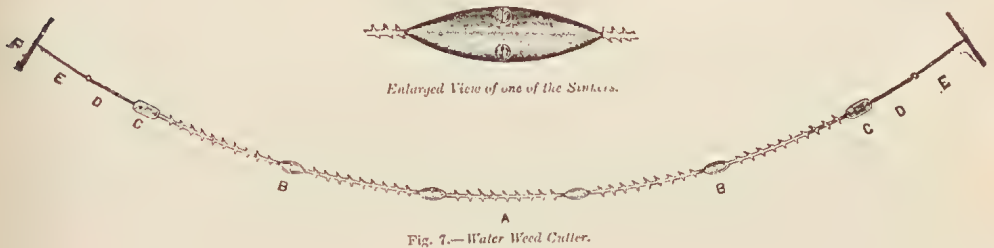

or slope of the banks, or to the inequalities at the bottom of the stream or lake. Such an appliance will be of great value in all districts where it is necessary to keep ponds, lakes, and rivers free from weeds in connection with fishing, boating, mill-driving, &c." Further particulars and prices can be had from Mr. Jackson at the address above given.

Answers to Correspondents.

TO MEASURE THE QUANTITY OF WATER AVAILABLE IN A STREAM.

CANE-GROWER, Lower Burdekin.—

There are several methods of measuring the quantity of water. They all resolve themselves into arrangements for estimating what engineers call the cubical content of a certain vessel, which is filled and emptied in a certain time, or the cubical measurement of water passing over a certain weir, placed for the purpose, and whose dimensions have been exactly measured. It should be mentioned that the weight of any quantity of water is easily found from its cubical measurement. Thus, 1 cu. ft. of water weighs $62\frac{1}{2}$ lb. If, therefore, the number of cubic feet of water passing a given spot in a given time can be measured, the quantity of water available is known at once. But the number of cubic feet may be always obtained by measuring the number of feet and inches of any given body, say a given body of water, every way. Thus, if we have a body of water lying in a trough, the dimensions of the trough being, say, 1 ft. wide, 6 in. high, and 2 ft. long, and the trough is filled and emptied, say, 100 times in a minute, the quantity of water passing through the trough per minute will be 100 cu. ft., or 100 times $62\frac{1}{2}$ lb., or 6,250 lb. One method of measuring, therefore, is to place a trough of known dimensions in the path of the stream to be measured, making sure that the whole of the stream has to pass through the trough, and taking the time for some object—say, a chip of wood—to pass through the trough. If the chip of wood takes one minute passing from one end of the trough to the other, it is evident that the trough is emptied in one minute. If the chip takes one second only, the trough is filled and emptied sixty times per minute, and so on. A more usual method is, a temporary weir is formed, by the aid of a piece of wood, so arranged that the whole of the water must pass over the weir. In the board forming the weir a notch is cut, which may be conveniently of rectangular form. That is to say, the two sides of the notch will be perpendicular, both the same height, and the bottom of the notch will be horizontal, and parallel with the top of the board. The notch cut in the board should not be longer, measured across the stream, than two-thirds of the total width of the stream. Thus, if the stream is, say, 3 ft. wide, the notch in the board should not be more than 2 ft. wide. The notch should be bevelled on the side away from the stream, so that the water may flow over it easily. That is to say, the top of the notch should be made wedge-shaped.

HOW TO MEASURE.

In arranging for the measurement of the water, a pond should be formed above the dam, containing an appreciable quantity of water, so that when it is allowed to run over the weir it will not flow too rapidly, as if it is allowed to do so the measurement obtained will be higher than it should be. The pond above the weir should be practically still, and the water should flow very gently, with hardly any perceptible motion at all, over the notch. It is also important that the bottom of the notch, the sill over which the water flows, should be exactly level, and that there should be from 8 in. to 10 in. of water between the bottom of the pond and the bottom of the notch. By measuring the rate at which a chip of wood thrown into the stream at any distance above passes down over the weir—that is to say, the time that it takes passing over a certain length of the stream—and multiplying this by the area of the notch, the quantity passing per minute may be obtained, in a similar manner to that described with the trough.

Where neither of these plans is convenient, the rate at which the stream flows may be measured, without damming it at all, by taking definite lengths of the stream, at different parts, and observing the time that a chip of wood occupies in passing over the given lengths. It is usual to take only four-fifths of the rate of flow of the stream obtained by this method, because the water on the surface always flows faster than that below. The depth and width of the stream are then averaged as carefully as possible. The width of the stream is measured in a number of places, being careful to take the actual width at the bottom, not that at the surface, where the bank often slopes. And the depth of the stream is taken by a pole marked in feet and inches, also at a large number of places. For both the width and depth the measurements taken are all added together and divided by the number of measurements, the result being the average width and depth. Thus, taking the measurements of the width of the stream as, say, 6 ft., $5\frac{1}{2}$ ft., $6\frac{1}{2}$ ft., 7 ft., and $3\frac{1}{2}$ ft., the total of the six measurements is 33 ft., and that divided by six, the number of measurements, is $5\frac{1}{2}$ ft., and this would be taken as the average width of the stream. Similarly, the whole of the measurements of the depth of the stream would be added together and divided by the number of measurements, and that would be taken as the average depth. Taking the width as $5\frac{1}{2}$ ft., and the average depth as 1 ft., if the rate of flow was 10 ft. per minute, when corrected, as described above, for the difference between the flow on the surface and below, the average quantity of water flowing per minute would be 55 cu. ft., and the average weight per minute would be 55 times $62\frac{1}{2}$ lb.—3,437 $\frac{1}{2}$ lb.

If you turn to the January issue of the Journal for 1903, you will find a full account of irrigation work in your district. In the June issue for the same year there is an article on the proposed irrigation of the Woongarra Scrub from the Elliott River.

The above method is given by Mr. S. F. Walker in "The Farmer and Stock Breeder."

THE DARLING PEA.

J. R. CAGNEY, Avondale, Boolburra.—

Mr. Sydney Dodd, Principal Veterinary Surgeon and Bacteriologist, to whom your letter and specimen plant were submitted, says:—The specimen forwarded by you on the 31st ultimo is what is known as the Darling Pea or Indigo Plant. Its poisonous properties are well known in Australia, especially among sheep, and the symptoms you describe as occurring in your colt are those which are attributed to this plant when eaten by horses. Mr. Bailey, the Colonial Botanist, in his article on "Plants Reputedly Poisonous to Stock," states that numerous cases have been recorded where the plant has poisoned horses, and the symptoms of the disease coincide with your description.

CASSAVA AS A FOOD STUFF.

W. INGLES NOTT, Westwood.—

At the Florida (U.S.A.) Experimental Farm cassava was proved to be the best and cheapest ration which can be used for fattening purposes. As to the comparative cost between cassava and maize, the difference was two-thirds in favour of the former.

Both varieties—sweet and bitter—contain hydrocyanic poison. In the sweet, the poison is in the skin; in the bitter, it is in the skin and juice. If fed to pigs as dug the animals will be poisoned; 1 gr. of prussic acid will kill a human being, 16 gr. will kill a horse; and some quantity between these two will kill a pig. On some lands sweet cassava will turn to bitter. The change

results from planting on a free level soil cuttings from plants grown on hilly stony land. The very productive variety known as "Mexico" is very apt to change in this way. To be safe, the tubers should be peeled and boiled before being fed to stock.

To determine how the material can be treated to render it safe as a stock food, Professor Carmody made a number of experiments (see "Queensland Agricultural Journal," Vol. XII., January, 1900). Treated with cold water for twenty-four hours, the amount of hydrocyanic acid left in the sliced green roots was 1.134 gr. per lb. Treated with cold water for twenty-four hours, water poured off, and treated with a second lot of water for another ten hours, the residue of poison was .301 gr. These were young roots. When old roots were treated with boiling water for nine hours, and the water poured off, no poison was left in the roots. It was thus shown that by treatment, as above shown, the roots can be rendered quite safe for food purposes.

Hydrocyanic acid is a very volatile poison, and if the roots are sliced and left for a time in the sun, then most of the poison is driven off. Tubers and cuttings may be obtained from the Kamerunga State Nursery, Cairns, on application to the Instructor in Tropical Agriculture, Mr. H. Newport. Plant in spring.

COTTON FROM NORMANTON.

W. HUTSON, Vanrook Station, Normanton.—

The sample of cotton sent by you to the Colonial Botanist is an excellent sample of Caravonica silk cotton. It is worth 2d. per lb. in the seed at Brisbane.

The Markets.

PRICES FOR FRUIT—ROMA-STREET MARKETS.

| Article. | NOVEMBER. | |
|--|-----------|--------------------|
| | Prices. | |
| Apples (Hobart), per case | ... | 13s. to 14s. |
| Apples (American), per case | ... | 12s. to 16s. |
| Apples (Cooking), per case | ... | 9s. |
| Apricots, per quarter-case | ... | 2s. 6d. to 3s. 6d. |
| Asparagus, per dozen bundles | ... | 5s. |
| Bananas (Cavendish), per dozen | ... | 2½d. |
| Bananas (sugar), per dozen | ... | 1½d. to 2d. |
| Cherries, per case | ... | 6s. to 8s. |
| Grapes, per case | ... | 3s. to 4s. |
| Lemons (Italian), per case | ... | 30s. to 32s. |
| Lemons (Italian), per half-case | ... | 16s. to 17s. |
| Lemons (Sydney), per case | ... | 12s. to 13s. |
| Mangoes, per case | ... | 2s. to 4s. |
| Oranges, per case | ... | 5s. to 7s. |
| Passion Fruit, per quarter-case | ... | 1s. 6d. to 1s. 9d. |
| Papaw Apples, per quarter-case | ... | 1s. 6d. to 2s. |
| Peaches, per quarter-case | ... | 2s. 6d. to 3s. 6d. |
| Pears, per quarter-case | ... | 4s. to 5s. |
| Pineapples, rough, per dozen | ... | 2s. to 2s. 6d. |
| Pineapples, smooth, per dozen | ... | 3s. to 4s. |
| Plums, per quarter-case | ... | 3s. 6d. to 4s. |
| Rock Melons, per dozen, according to size | ... | 4s. to 7s. |
| Strawberries, per dozen boxes | ... | 2s. |
| Tomatoes, per quarter-case | ... | 1s. 3d. to 1s. 6d. |
| Water Melons, per dozen, according to size | ... | 8s. to 9s. |

SOUTHERN FRUIT MARKET.

| | | |
|---|-----|---------------------|
| Apples (Tasmanian) eating, per case | ... | 5s. to 15s. |
| Apples (Tasmanian) cooking, per case | ... | 5s. to 10s. |
| Apples, American, per case | ... | 12s. to 15s. |
| Apricots, per box | ... | 4s. to 7s. |
| Bananas, Queensland, per case | ... | 14s. to 15s. 6d. |
| Bananas, Queensland, per bunch | ... | 3s. 6d. to 5s. 6d. |
| Cherries, per quarter-case | ... | 2s. 6d. to 7s. |
| Gooseberries, per quarter-case | ... | 3s. to 4s. |
| Guavas (Cherry) per quart | ... | 6d. |
| Lemons, per case | ... | 10s. to 16s. |
| Mandarins, per case | ... | 8s. to 15s. |
| Mandarins, Special Emperor, per case | ... | 20s. to 25s. |
| Nectarines, per case | ... | 6s. |
| Oranges (Local), per case | ... | 10s. to 12s. |
| Oranges, Navel, per case | ... | 14s. to 15s. |
| Passion Fruit, choice, per quarter-case | ... | 5s. to 7s. |
| Passion Fruit (medium), per quarter-case | ... | 2s. 6d. to 4s. |
| Passion Fruit (small), per quarter-case | ... | 2s. |
| Peaches, China, per half case | ... | 6s. to 8s. 6d. |
| Pears, American, per case | ... | 16s. to 18s. |
| Pineapples, Queensland (common), choice, per case | ... | 6s. to 10s. |
| Pineapples (Ripley Queen), per case | ... | 6s. 6d. to 10s. 6d. |
| Pineapples (Queen's), per case | ... | 8s. to 10s. |
| Plums, per gin case | ... | 6s. |
| Rock melons (Queensland), per case | ... | 4s. to 5s. |
| Strawberries, choice, per dozen quart punnets | ... | 7s. to 9s. |
| Strawberries, good, per dozen quart punnets | ... | 4s. to 6s. |
| Tomatoes, Queensland, choice (coloured), per quarter-case | ... | 5s. to 7s. |
| Tomatoes, Queensland, good, per quarter-case | ... | 2s. 6d. to 3s. 6d. |
| Water melons, Queensland, per crate | ... | 20s. |

**PRICES OF FARM PRODUCE IN THE BRISBANE MARKETS FOR
DECEMBER.**

| Article. | | DECEMBER. | |
|------------------------|-----|-----------|------------------------|
| | | Prices. | |
| Bacon, Pineapple ... | ... | lb. | 9d. to 10½d. |
| Barley, Malting ... | ... | ... | ... |
| Bran ... | ... | ton | £5 10s. |
| Butter, Factory ... | ... | lb. | 10d. to 1s. |
| Chaff, Mixed ... | ... | ton | £5 10s. |
| Chaff, Oaten ... | ... | ... | £4 10s. to £4 12s. 6d. |
| Chaff, Lucerne ... | ... | ... | £4 15s. to £6 5s. |
| Chaff, Wheaten ... | ... | ... | £4 10s. to £5 10s. |
| Cheese ... | ... | lb. | 5d. to 5½d. |
| Flour ... | ... | ton | £9 15s. |
| Hay, Oaten ... | ... | ... | £7 to £7 10s. |
| Hay, Lucerne ... | ... | ... | £3 10s. to £4 10s. |
| Honey ... | ... | lb. | 2¼d. to 2½d. |
| Maize ... | ... | bush. | 4s. 1d. to 4s. 2d. |
| Oats ... | ... | ... | 3s. 9d. to 4s. 3d. |
| Pollard ... | ... | ton | £6 10s. to £6 15s. |
| Potatoes ... | ... | ... | £5 to £7 10s. |
| Potatoes, Sweet ... | ... | ... | ... |
| Pumpkins ... | ... | ... | ... |
| Wheat, Milling ... | ... | bush. | 4s. 6d. |
| Wheat, Chick ... | ... | ... | 4s. 11d. |
| Onions ... | ... | ton | £6 10s. to £7. |
| Hams ... | ... | lb. | 1s. 0½d. to 1s. 1½d. |
| Eggs ... | ... | doz. | 9½d. to 1s. 1½d. |
| Fowls ... | ... | pair | 2s. 6d. to 5s. 1d. |
| Geese ... | ... | ... | ... |
| Ducks, English ... | ... | ... | 3s. 4d. to 4s. 6d. |
| Ducks, Muscovy ... | ... | ... | 5s. to 7s. |
| Turkeys (Hens) ... | ... | ... | 8s. to 8s. 6d. |
| Turkeys (Gobblers) ... | ... | ... | 13s. to 26s. |

ENOGGERA SALEYARDS.

| Animal. | | NOVEMBER. | |
|--------------------|-----|-----------|------------------------|
| | | Prices. | |
| Bullocks ... | ... | ... | £9 15s. to £12 2s. 6d. |
| " (single) ... | ... | ... | ... |
| Cows ... | ... | ... | £7 10s. to £8 |
| " (single) ... | ... | ... | £9 5s. |
| Merino Wethers ... | ... | ... | 20s. |
| C.B. ... | ... | ... | 18s. 6d. |
| Merino Ewes ... | ... | ... | 14s. 9d. |
| C.B. ... | ... | ... | 19s. |
| Lambs ... | ... | ... | 14s. 9d. |
| Pigs (bacon) ... | ... | ... | ... |
| Pigs (slips) ... | ... | ... | ... |

Farm and Garden Notes for February.

FIELD.—The land intended for potatoes should now be ready for planting. Plant sound small potatoes, well shot, without cutting them. If large potatoes are cut into setts, there is a risk of their rotting, as the usual wet weather may be expected, with a hot, muggy atmosphere. Weeds will be very troublesome, and for that reason the sowing of lucerne should be deferred till later. Sow lucerne in deep rich soil, thoroughly worked, and deeply ploughed. Cape barley, panicum, Kafir corn, imphee, sorghum, and vetches may be sown, but it is risky to plant maize for a late crop, as early frosts would destroy the ripening grain. For an early winter crop sow swede turnips and mangelwurtzels.

KITCHEN GARDEN.—Make preparations for good crops of vegetables for the early winter by ploughing or digging all unoccupied land, supplying well-rotted manure if needed. Chicken guano is also an excellent fertiliser, if prepared as follows:—

Spread a layer of black soil on the ground. Dump the fowl manure on to this, and pound it fine with the back of a spade; add hardwood ashes, so that the compound shall contain—Soil, 3 bushels; fowl manure, 2 bushels; ashes, 1 bushel. Mix thoroughly, and a little before planting moisten the heap with water, or, better still, with urine; cover with old mats, and let it lie till needed.

Most market gardeners will have cabbages and cauliflowers ready for transplanting. Do this during the month. Read the article in the December number of the Journal issued by this Department (1907); also in the pamphlet on "Market Gardening," on the growing of cabbages and cauliflowers, in which it is recommended to sow the seed from the middle of January to the middle of March, arranging the time, however, to suit early and late districts. For winter crops the Drumhead type, of which Flat Dutch and Queensland or Florida Headen are good examples, are the most profitable. The Savoy cabbage does well here. The best cauliflowers to grow are the Large Asiatic, Eclipse, Early Dwarf, and Le Normand. If the aphid appears, spray with tobacco solution.

Sow French beans, butter beans, beet, carrot, turnip, radish, cabbage, cauliflower, cress, peas. Should the weather prove dry after the January rains, give the plants a good soaking with water. Gather all fruit of cucumbers, melons, French and other beans, and tomatoes as they ripen, to ensure the continued production of the vines and plants.

FLOWER GARDEN.—Thin out and tie up dahlias. Keep the weeds down, and never allow them to seed. Sow hardy annuals. This is the best month for sowing, as you will be able to keep up a succession of bloom during the succeeding months of autumn and winter. To ensure this, sow phlox, pansy, daisy, stocks, aster, nasturtium, hollyhocks, candytuft, mignonette, sweet peas, dianthus, carnations, cornflower, summer chrysanthemums, verbenas, petunias, pentstemons, &c. Dianthus, sown now and planted out in March, will bloom during the whole year if the dead stalks and blooms are regularly cut away.

Do not sow flower seeds too deep, as on the depth will depend greatly what results you will have as regards the seed germinating. It is easy to remember that seeds should be covered with fine soil to a depth equal to their own size—for instance, a pea is about one-eighth of an inch in diameter, therefore, cover it with one-eighth of an inch of soil.

Orchard Notes for February.

By ALBERT H. BENSON, M.R.A.C.

In order that the series of monthly notes that have appeared for some years past in the "Agricultural Journal" might be rendered of more value to our fruit-growers, I took advantage of the commencement of the new year of 1908 to revise them and bring them up to date. At the same time, I somewhat altered the notes, as, instead of making them of a general nature, applicable to the whole of the State, I endeavoured to localise them to a certain extent, as, in my opinion, although the general principles of cultivation, manuring, pruning, treatment of fruit pests, as well as of the handling and marketing of the fruit are applicable to the State as a whole, there are many matters that are of interest to individual parts of the State rather than to the whole State; and, further, notes that are applicable to the Southern part of the State for one month are not always applicable to the North for the same month.

In order to carry out this idea I divided the State as follows:—

1. The Southern Coast Districts, south of the Tropic of Capricorn;
2. The Tropical Coast Districts;
3. The Southern and Central Tablelands.

This plan has met with such general approval during the past year that the notes will henceforth be published in accordance therewith.

THE SOUTHERN COAST DISTRICTS.

The earlier summer fruits, including grapes, will be pretty well over, but pineapples, mangoes, and bananas are in full fruit. The bulk of the main summer crop of pines ripens during the month, and growers are in consequence kept very busy sending them to both our local markets and canneries, and to the Southern States. The planting of all kinds of tropical fruits can be continued where necessary, though earlier planting of both pines and bananas is to be recommended. Still, if the land is thoroughly prepared—viz., well and deeply worked—they can be planted with safety, and will become well established before winter. The month is usually a wet one, and both tree and weed growth is excessive. If unable to get on the land with horses to keep down weed growth, use the scythe freely in the orchard before weeds seed, as by doing so you will form a good mulch that will tend to prevent the soil washing, and that when ploughed in later on will add a considerable quantity of organic matter to the soil, thus tending to improve its mechanical condition, its power of absorbing and retaining moisture, as well as to increase its nitrogen contents.

This is the best month of the year in which to bud mangoes in the Brisbane district. The bark of the stock to be budded must run very freely, and the scion, when placed in position, must be tied very firmly. The bark of the scion should be slightly thicker than the bark of the stock, so that the material used to tie it keeps it firmly in its place. As soon as the bud is tied ringbark the stock just above the bud, so as to force the sap of the stock into scion so that a union will take place quickly.

Where cyaniding of citrus and other trees has not been concluded it may be continued during the month as fruit treated now will probably keep clean and free from scale insects till gathered. If the trees have been treated with Bordeaux mixture, do not cyanide, as cyaniding should always be done previous to spraying with Bordeaux mixture.

If Maori is showing, spray with the sulphide of soda wash. Look out for Black Brand and also for the Yellow Peach Moth towards the end of the month in the earlier districts. Spraying with Bordeaux mixture is advisable in the case of both of these pests.

Get land ready for strawberry planting, so as to be ready to set out runners next month. Some growers set out plants as early as the end of February, but I prefer March. Citrus and deciduous trees can still be budded during the month. Young trees in nursery should be kept clean and attended to; ties should be cut where necessary, and the young trees trained to a straight single stem.

THE TROPICAL COAST DISTRICTS.

As the month is usually a very wet one in this part of the State, very little work can be done in the orchard other than keeping down excessive weed growth by means of a scythe. When citrus trees are making excessive growth and throwing out large numbers of water-shoots, the latter should be cut away, otherwise they are apt to rob the rest of the tree, and thus injure it considerably. Many of the citrus trees will come into a second blossoming during the month, and this will produce a crop of fruit ripening towards the end of winter and during the following spring. The main crop, where same has set in spring, will be ripening towards the end of the month, but as a rule insect life of all kinds is so prevalent at this time of year that the bulk of the fruit is destroyed. Where there is sound fruit, however, it will pay to look after. If the weather is wet it should be artificially dried before packing, but if there are periods of sunshine, then the fruit can be cut and laid out on boards or slabs in the sun, so that the extra moisture of the skin can be dried out. Care will have to be taken not to sun-scald the fruit, or to dry it too much; all that is required is to evaporate the surplus moisture from the skin, so that the fruit will not speck when packed.

Tropical fruits of all sorts can be planted during the month. Budding of mangoes and other fruits can be continued. Bananas must be kept netted, as fly is always bad at this time of year.

THE SOUTHERN AND CENTRAL TABLELANDS.

The marketing of later varieties of apples, pears, plums, peaches, and nectarines will occupy the attention of the Stanthorpe growers. The grape harvest will also extend right through the month. Every care should be taken to see that the fruit fly and codling moth are not allowed to spread, although the best work in fighting these pests has to be done during the months of December and January, as on the action then taken, if carried out systematically, the freedom of the later fruits from infestation mainly depends.

Handle the fruit carefully, and see that no fly or codling moth infested fruit leaves the district. The grapes, ripening as they do when this fruit is over in the earlier parts of the State, should be sent not only to Brisbane but to all other parts of the State. For long shipment nothing can beat crates holding 6-lb. baskets. The fruit should be gathered some hours before packing, and be placed in the sun, so as to become thoroughly dry, and to allow the stems to become wilted, as this causes the fruit to hang on the bunch much better, and consequently to reach its destination in better order.

If parrots and flying foxes are troublesome, organised shooting parties or poisoning with strychnine are the best means of dealing with those pests.

The crop of grapes will be about over in the Roma and other inland districts. Citrus trees, when infested by Red Scale, should be cyanided. The orchard should be kept well cultivated after every rain, and when there is no rain, but water is available for irrigation, if the soil requires it, the trees should get a good soaking, which, if followed by thorough cultivation, will carry the trees on till the fruit is ripe.

54



Agriculture.

SORGHUM POISONING.

We have at various times published articles in connection with sorghum poisoning, and, in them, have pointed out how the ill effects of green sorghum on stock can be minimised or entirely prevented. About April, 1908, the "Journal of Agriculture" of Victoria contained an article contributed by the chief veterinary officer of the State on the danger of feeding green sorghum (also known as Guinea corn and millet) to cattle, and from the particulars given it would seem that the risk of poisoning, which is due to prussic acid contained in the plant, is in an inverse ratio to the vigour of the growing crop, since prussic acid is found present in increased quantity in stunted crops and during dry seasons, while it is almost absent in the case of plants that have grown quickly on moist land. Second growths, which are usually inferior in quantity and quality, are also stated to be more dangerous than first crops. The amount of prussic acid present in the plant is also largely increased as the result of heavy dressings of nitrogenous manures.

The prussic acid is present in dangerous amount only in certain stages of growth, from five to seven weeks usually, and gradually disappears shortly after the blossoming stage when the ears begin to form. By the time the seed is ripe the poison has completely disappeared.

Green sorghum should be fed only in small quantity, and never when in an immature state. If the plant is put in the sun to dry after cutting, the danger quickly disappears, since prussic acid is a volatile compound.

With reference to the above remarks, "The Agricultural News" of Barbados says:—

"It may be mentioned that prussic acid does not occur in the free state in the growing plant, but is yielded by a glucoside present, when the latter compound is acted upon by an enzyme or ferment also occurring in certain parts of the plant. The amount of glucoside present, and therefore the possible amount of prussic acid that may be formed, diminishes as the plant approaches maturity.

"Earlier experiments appeared to indicate that, on drying the sorghum in the sun, the plant lost its possibly poisonous properties. Later experiments, however, carried out at Melbourne, and in the laboratory of the Government of India, have shown definitely that this is not the case, and that the glucoside present is unchanged by sun-drying."

LUCERNE-GROWING.

The rapid expansion of the dairying industry in Queensland has naturally caused great attention being paid to experiments with several varieties of fodder grasses. In some countries where the industry takes precedence of all other farming pursuits—Wisconsin, for instance, in the United States of America—enormous sums are annually paid by dairy farmers for high protein feeds, such as oil-meal, oil-cake, cotton-seed meal, bran, &c., with which to balance the feed ration. Of the fifty million dollars (£10,000,000) brought in to the farmers for milk products annually, a very large proportion, in cash, labour, and time, is expended in purchasing and carting these feeds and, necessarily, the farmers lose a large portion of what would otherwise be profit.

Under these circumstances, they turned their attention to fodder grasses, and amongst these lucerne—or, as it is called in America, alfalfa—was found to

be the best of all feeds for farm animals, including swine and poultry. No single forage plant contains the materials for a profitable ration for dairy cows, sheep, and swine in the same degree as lucerne.

On a station farm near Madison, lucerne has been grown for several years successfully, says Mr. R. A. Moore, of the Agricultural Experiment Station of the University of Wisconsin, and many tests made to determine the best method of growing it under different conditions of soil and climate. When grown in comparison with red clover, timothy, and brome grass during the season of 1904, the yield per acre of hay was 5·4 tons for alfalfa, 2·5 tons for clover, 2·3 tons for timothy, and 1·3 tons for brome grass. As a green forage the weight of alfalfa grown per acre was double that of clover, three times that of timothy, and five times that of brome grass. The per cent. of protein found in the hay was as follows:—18·7 for alfalfa, 13·28 for clover, 4·74 for timothy, and 6·07 for brome grass. In total yield of protein per acre alfalfa produced three times that of clover, nine times that of timothy, and twelve times that of brome grass.

The abundant root development of lucerne, and the great depth to which the roots extend when once established, enable the plant to secure food and moisture several feet below the surface. On the station farm lucerne that had been seeded one year had main roots extending to the depth of 3 ft., and, where seeded for three years, had roots extending to the depth of 5 ft. Lucerne is said to extend its roots to the depth of 20 ft. and over, and is regarded as one of our greatest soil renovators.

Good growths of lucerne are often secured in favourable seasons on level land, but better results will be obtained on land that is somewhat sloping, where water will not stand during any portion of the year. "Patchy fields" are hard to renew, and generally necessitate reploughing and reseeded. In no case should lucerne be sown on land that is subject to overflow, or where the water level is but 2 or 3 ft. below the surface. Lucerne will grow on a wide variation of soil, ranging from a rich sandy loam to a heavy clay, but a rich clay loam over a gravelly subsoil seems to be best. It is practically useless to try to grow lucerne on sandy or "worn-out" soils without an abundant supply of good barnyard manure.

In the coast districts of Queensland, lucerne thrives best on alluvial flats and pockets on the banks of the creeks, where the lands are periodically fertilised by the overflow from the streams. Lucerne is a deep-rooter. It strikes down to a depth of 15 ft., and even from this depth continues to descend until it meets a hard subsoil or clay, which the roots cannot penetrate. When the plant reaches this stage it is at a standstill. Deterioration shortly afterwards begins to manifest itself, and the plant loses its vigour. Lucerne will hold fairly good for ten years. After this space of time the natural grasses begin to show, and the lucerne dies out. Land in which it is intended to plant lucerne requires good cultivation, and should be thoroughly mixed; three crops, at least, of maize or wheat should be taken off the ground prior to the sowing of the lucerne seed. These croppings cause the land to be worked thoroughly, and enable the agriculturist to rid the paddocks of all natural grasses, including couch and nut grasses, which are the deadly enemies of lucerne. If these are allowed to remain, the lucerne will not thrive, but will die out in a short time.

On the rich lands of the Darling Downs and on the plains in the Lockyer district, lucerne thrives to perfection.

The following instructions for growing this crop are intended more for the benefit of new settlers than for those farmers who have for many years been successful growers of this invaluable stand-by of the dairy farmer:—

"The best land for lucerne is a deep alluvial soil, such as that on the banks of many of our rivers and creeks. If this is not procurable, the next best is that of the deep black soils of the plain country of the Darling Downs and other parts of the State. Shallow land, or land having a hard, retentive

clay subsoil or hard-pan, should be avoided, as the lucerne plant is a deep rooter and requires a deep soil for its full development. No land is well adapted for lucerne-growing unless it contains a sufficient quantity of lime, as the presence of this plant-food is essential to its growth.

"**PREPARATION OF THE LAND.**—Plough the land deeply some months before the seed is sown, so as to get it into the right condition. That means that the whole furrow must be brought into a state of fine tilth, so that when the seed germinates the young roots will be able to at once strike down deeply into the soil.

"**SOWING.**—The best time to sow the seed is from the middle of March to the end of April, as this enables the lucerne to get a good root-hold before the winter sets in, and thus be able to withstand the effects of the frost.

"The drill is undoubtedly the best machine with which to sow the seed, as by its means the seed is more evenly distributed over the land than by hand sowing. From 10 lb. to 20 lb. of seed is usual per acre.

"I believe in sowing the seed through the coulter, not by means of a broadcast drill, as the seed is thereby placed at an even depth and, consequently, comes to the surface more regularly. It is a good plan to attach a light wooden harrow to the drill so as to smooth the land behind the drill, and to follow this by rolling as soon after as possible.

"If the seed is sown in autumn, the lucerne will, in an ordinary season, be fit to cut for hay in September. Lucerne is best sown by itself, as the presence of stubble or other rubbish, which is always present when the seed is sown with wheat or oats, is thus avoided.

"**AFTER CULTIVATION.**—Once lucerne is established, say in twelve months after seeding, it is a difficult matter to over-cultivate it. The spring-tooth harrow or disc harrow is a grand implement to run through the lucerne after each crop is taken off, but if this is not always practical there must be at least one cultivation every spring. The more lucerne is cultivated the better it grows.

"**HARVESTING.**—The best time to cut lucerne for hay is just when the first blossom is showing. The great mistake which most of our lucerne-growers make is in allowing the lucerne to get too far advanced before cutting.

"**GRAZING.**—The great trouble in grazing lucerne is, that sheep and cattle are very liable to what is termed "blowing," but this can be overcome to a great extent by not letting the stock on to a paddock until the lucerne is 6 or 7 in. high. Once on lucerne, let the stock stay there, and, if this precaution is taken, my experience has been that there is practically no danger from "blowing."

"**LUCERNE FOR SEED.**—When lucerne is being grown for seed, the plants should be at least three years old, as it is not advisable to take off a crop of seed till the plants have reached full maturity, and become thoroughly established. A dry season is far better for getting a crop of seed than a wet one.

"The best time to cut lucerne for seed is when the lower pods are quite ripe and the upper pods are just turning brown.

"Cut with an ordinary mower, taking care to remove the crop as cut out of the way of the horses by having one or two men to follow the mower for this purpose. A sidedelivery reaper, or a reaper and binder without string binding attachment, can also be used.

"When cut allow it to become thoroughly dry before stacking, or, better still, if machinery is available, thresh at once from the field, without stacking.

"The ordinary wheat-threshing machine is suitable for threshing lucerne—in fact, it answers the purpose very well, with a little alteration.

"**YIELD.**—The yield of seed per acre varies from 50 to 400 lb. per acre, which, provided all weather conditions are favourable, is a good paying crop, but the risks are great, as at least two good crops of hay have to be sacrificed to get one crop of seed."—W. D. LAMB, Yangan.

Sometimes the land becomes what is known as *lucerne sick*. This is owing to the land having been too long under lucerne. In such a case a two-years' rest is needed. The land may either be fallowed for one season, and a crop of potatoes or corn taken off in the following season, or green fallow the land for two years, taking one crop of some cereal each year.

Some thirty-five years ago a disease, or rather a harmful parasite, of the lucerne plant was introduced from New South Wales. This was the "Dodder" (*Cuscuta australis*). It is a kind of hair-like vine which creeps up the lucerne stems, twines round them, and, by means of small suckers or rootlets, feeds on the sap of the plant. If allowed to spread, the field rapidly assumes the appearance of having been attacked by ringworm. The main root of the dodder dies, but its tendrils spread in a circular form, leaving the lucerne in great yellow circles. The remedy is at once to dig out the lucerne so affected the moment it is noticed. Great care is required in removing it, as the least particle of dodder, if dropped elsewhere in the field, will grow. The bare patches should be sprayed with sulphate of iron. The solution should contain as much sulphate as a cask of water will take up. The lucerne and dodder should be removed and burnt, or even burnt on the spot, which is then to be watered with the liquid. Mr. J. Whitely, of Wycarbah, recommends first to destroy the lucerne and dodder by fire, and then to mulch the spot heavily (say 4 to 6 in.) with dry grass. This effectually chokes the dodder, but the lucerne will grow through it. When required to be mown, the mulch should be removed. It is not at all necessary by adopting this plan to dig up the lucerne roots.

The cost of preparing the land, of seed, and sowing will reach about 25s. per acre, and no further expense is entailed, once the field is established, for several years.

LUCERNE HAY-MAKING.

It may seem superfluous to write on this subject, seeing that for years farmers all over the coastal and Downs districts have been growing lucerne, and thoroughly understand the art of saving the crop. There are, however, many new beginners who have never had anything to do with hay-making, and a few words to put them on the right track may be of service to them. Every farmer knows that the whole success in hay-making lies in properly saving it. The first thing is to know when it is most advantageous to cut the crop for hay. The proper time is when the plants are just coming into bloom. Lucerne is one of those crops which suffer considerably by age, and if allowed to grow a couple of weeks after the plants are one-third in blossom, there will be a marked diminution in the total weight of crop as well as in the digestible food. Care should be taken, as far as possible, to mow when the weather bids fair to keep fine. After mowing it should lie in the field for a day or longer if the weather is cool. Lucerne must be very gently handled in order to prevent the loss of leaves, as it is on its leafiness that its market value depends. If rain should come on just after mowing, it is well to make small cocks, and spread the hay out again as soon as the rain has ceased. A better way, if the rain continues, is to put the lucerne at once into the silo. This will save the whole cut crop, whereas it would be rendered valueless if exposed to continuous heavy rain in the field. In our hot summer climate, a day is sufficient for the cut lucerne to lie on the ground. It should then be raked together, and cocked for another day or two, when it may be carted to the stack. Lucerne hay should be made quickly to avoid loss of leaves and colour. When stacked, do not be in too great a hurry to market it in bale form. Let it remain until it has finished sweating. If pressed too soon, it becomes musty or mouldy, and as a consequence the market price is depreciated. There is no difficulty in making lucerne hay, provided that the proper moment for cutting is chosen, that the weather be reasonably fine, and that care is taken in handling the hay.

ONION MILDEW.

This troublesome parasite, which is to be found in all countries where the onion is grown, is caused by a fungus, a near relation of the dreaded potato-blight. All members of the onion family are subject to attack, the leaves being the organs which are directly affected. The first signs of disease consist of the development of yellowish patches on the leaves. These areas soon become covered with a delicate coating of mould, much as if they had been powdered with flour. This coating soon changes to a grey or light-brown colour. Meanwhile the disease increases rapidly until the whole leaf is affected and withers away. The appearance of "thick neck" is especially characteristic of this disease. The bulbs are not directly attacked, but if the disease appears early in the year they remain extremely small, and do not mature properly, so that the crop is practically ruined.

There are two methods of reproduction—first, by summer spores, which serve to disseminate the disease from crop to crop during the growing season; and, secondly, by rounded thick-coated bodies, called resting spores, which are produced in the decaying tissues of the leaves, and remain dormant throughout the winter. In the spring they germinate, and inoculate the young crop.

Treatment.

The crop should be thoroughly sprayed with Bordeaux mixture, using the 4-4-40 formula as a preventive. If this has been neglected, then spray as soon as the disease is detected. This spraying should be repeated whenever the disease appears to be gaining ground. The use of potassium-sulphite—1 oz. to 2 gallons of water for small plots, as it is more easily prepared than Bordeaux mixture, although not quite so reliable—is recommended.

Bordeaux Mixture.

4 lb. sulphate of copper; 4 lb. fresh lime (if fresh lime is not obtainable use 5 lb. of ordinary washing soda instead of 4 lb. of lime); 40 gallons of water.—"New Zealand Farmer."

TEESWATER SHEEP.

The old Teeswater breed of sheep was the largest in England (says "The Live Stock Journal"). Four-year-olds were killed, which weighed 55 lb. per quarter, and even more. Mr. Thomas Hutchinson, of Stockton, an eminent breeder and grazier, killed at Christmas, 1779, a wether which scaled 17 st. 11 lb. (14 lb. to the stone), with 17 lb. of tallow. This, says Culley, was the heaviest sheep by several pounds per quarter he ever heard of. The animal was of the "true old Teeswater breed," which was famed for its mutton. These sheep were not kept in large flocks, and could not thrive on poor ground, and the practice was to depasture them in small numbers in small enclosures of the best grass. The enclosures were well sheltered, and the sheep had access to a stack of hay in the winter. The Teeswater ewes were prolific breeders. Mr. Edw. Eddison possessed one which, in the six years 1772-77, produced twenty lambs, the first nine in eleven months!

ARROWROOT-GROWING IN QUEENSLAND.

Mr. Henry Lane, James street, New Farm, writes:—

"I was greatly interested in reading your article under above heading in the January number, and I have been thinking that you might accept a few notes from me.

"Permit me to say that, although not mentioned in H. N. L.'s reminiscences, I was one of the pioneers in the arrowroot industry in Queensland,

where, in the early seventies of last century, I carried on operations in a small way at my farm at North Pine. When I exhibited in Brisbane, without any competition, Governor Cairns, who, prior to his term in Queensland, was Governor of The Bermudas, and, as he himself said, knew arrowroot when he saw it, bestowed upon my product the highest praise, remarking that he had never seen it excelled, even in the West Indies.

"Encouraged by Governor Cairns' encomiums, I prepared an exhibit for the Great International Exhibition at Philadelphia, in 1876, when, in competition with growers from all parts, including The Bermudas, I was awarded medal and diplomas of the highest value, testifying to the superiority of Queensland-grown arrowroot.

"These awards—which I prize very much—I have had framed for preservation, and shall be pleased to show to any interested reader.

"I also exhibited with success in England in the eighties, but unfortunately lost my English certificates in the 1893 flood.

"The arrowroot I sent to St. Bartholomew's Hospital, London, was esteemed most highly, the faculty there giving my product the most unstinted praise, whilst, for a small shipment marketed for me in England by my late friend, Mr. Schwabe, I obtained the satisfactory return of 2s. 9d. per lb.

"I may mention that, like Major Boyd, in his interesting experiments, my appliances were of the crudest and most primitive type, yet I succeeded in demonstrating what can be done successfully in the arrowroot industry, which I claim should figure well up in the products of our State.

"As to returns, it is the old old story, which to our shame has to be acknowledged—viz., that, when it was seen that the article commanded such high prices and good returns, shipments were faked, as has been the experience in butter, honey, and other products. As regards the arrowroot market in London, the business was pretty well ruined by a large shipment from Brisbane, which was found to be heavily loaded with the flour of sweet potatoes.

"I am now in my 83rd year, and not in the running; could I but put back the shadow on the dial, I would endeavour to show our younger generation, with all their incalculable advantages, how to capture the arrowroot market of England, as well as to grip the local starch business.

"If any person going into arrowroot-growing cares to call upon me, I shall be pleased to give him the benefit of my experience and advice."

CROPS AT HERMITAGE STATE FARM, SEASON 1908.

Sixty-day Oats.—Several years ago a small sample packet of this cereal was imported from America, to which place it had been introduced from Russia by the Bureau of Plant Industry, an organisation devoted to the selection of seeds and plants from foreign countries.

The variety was described as specially drought resistant. Its chief value lies in its hardiness and the excellence of the plant for making a fine quality of hay. It is quick in maturing, but the name "sixty day" is a misnomer. The grain is thin and light, and not suitable for a feed oat.

Kubanka Wheat.—A bearded macaroni type, which owes its introduction to America from Russia, and was imported several years ago into Queensland. The hardiness and drought-resistant qualities of this wheat have been cited by American authorities as the chief factors in admitting of the extension of their wheat-growing belt into arid regions. It is not to be wondered at that particular attention has been paid to the selection of prolific types. From time to time these improved strains have been imported into Queensland for trial.

After several years of tests on the Downs, and latterly in the Maranoa, it is evident there are many wheats in the State superior to macaroni types as drought-resisters; furthermore, the beard is most objectionable to handle in

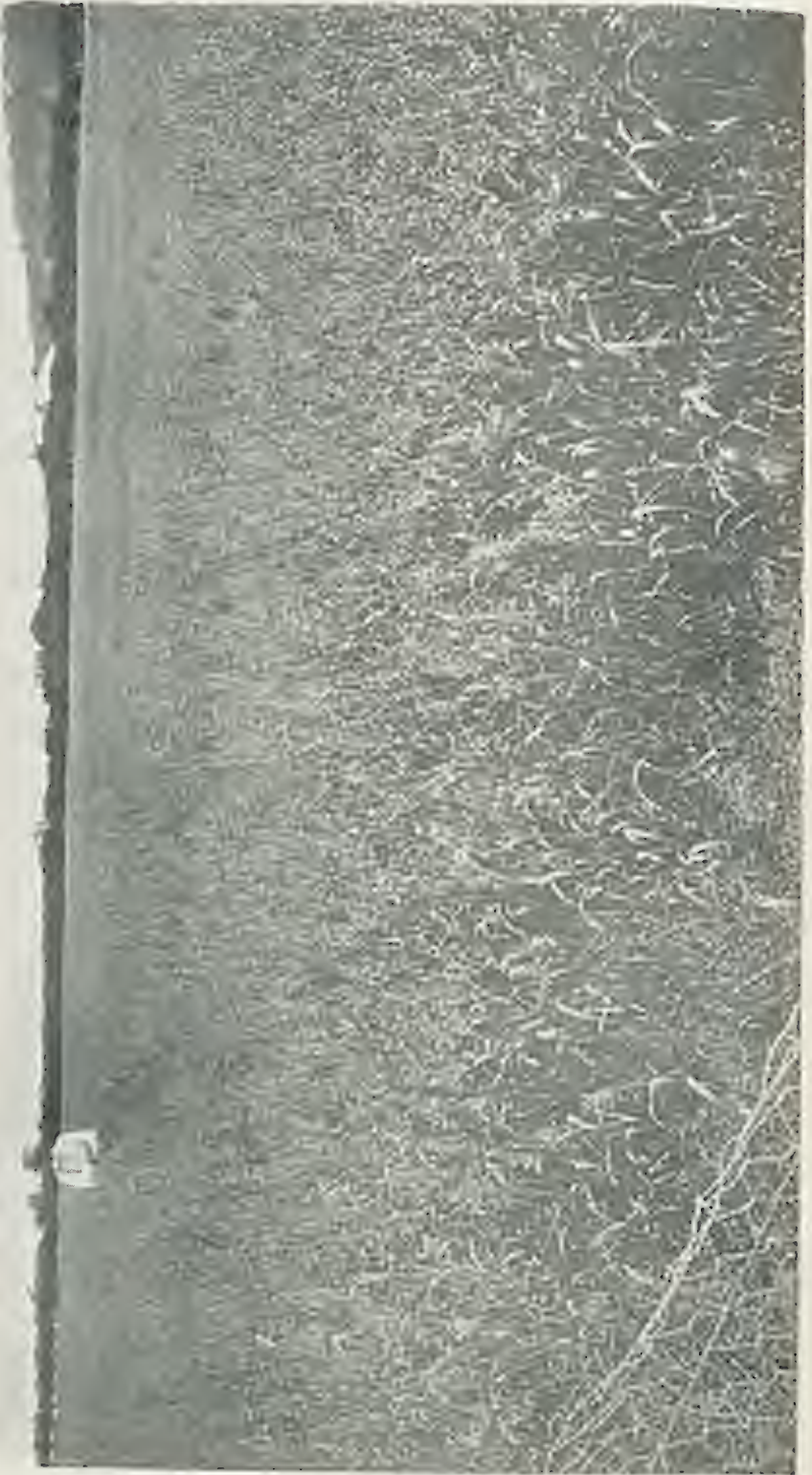

CROP OF SIXTY-DAY OATS, HERMITAGE STATE FARM.



Plate X.



HERMITAGE STATE FARM.

1. Plot of Pratt's Comeback Wheat.
2. Plot of Kubanka Macaroni Wheat.



Plate XI.



CROP OF CANARY SEED, HERMITAGE STATE FARM.





FIELD PLOT OF No. 2, SOUTH AUSTRALIAN WHEAT, AT HERITAGE STATE FARM.



FIELD CROP OF POTATOES, HERMITAGE STATE FARM.

harvesting and threshing. Until such time as a demand springs up for macaroni wheat, there is nothing to be gained by growing it, except on the coast, for poultry feed.

Canary Seed.—This crop is worthy of being included as an adjunct to wheat-growing on the Downs, as, with a little alteration of the same machinery which deals with wheat may be adapted to handle canary seed.

The period of seeding and harvesting is identical with wheat, with this advantage: That canary seed ripens a little earlier.

The plant makes good green feed, and is valuable for hay-making. Its immunity to rust and fungoid diseases offers a greater reliability of return.

Pratt's Comeback.—The crop shown in the illustration was raised from seed secured in South Australia. It resembles certain types of wheat raised by the late William Farrer, of Queanbeyan.

It has an attractive-looking straw and an early habit. Observations have not been extensive enough to determine its value as a rust-resister, but during the present season it has come away and ripened early enough to escape the visitation. The straw, when ripening, appeared to lose its vitality to a certain extent.

No. 52 (Sown 20th June, 1908).—This, together with several other wheats, distinguished for the present by numerals, is being grown over a series of seasons at Hermitage to assist the Department of Agriculture in South Australia to arrive at certain conclusions, after comparisons are made with identical varieties grown in the several States of the Commonwealth.

It is a red chaffed variety, carrying a stiff erect straw similar in characteristics to "John Brown" wheat, a New South Wales production. So far, it has done very well, and gives promise of a good yield this year, notwithstanding the fact that rust enveloped all late maturing plants and patches in the crop.

The following interesting comparison of the analyses of the Kubanka and Budd's Early wheats has been kindly supplied by Mr. J. C. Brünnich, Agricultural Chemist:—

| Name of Wheat. | Weight in lb. per bushel. | % Nitrogen in Wheat. | % Total Proteids in Wheat. | MILLING PRODUCTS. | | | GLUTEN IN FLOUR. | | | Strength of Flour, Quarts per Sack. |
|---------------------|---------------------------|----------------------|----------------------------|-------------------|-----------|---------|------------------|--------|-------------------|-------------------------------------|
| | | | | % Flour. | % Pollard | % Bran. | % Wet. | % Dry. | Ratio Wet to Dry. | |
| Kubanka | 62.8 | 2.635 | 16.45 | 71.8 | 13.7 | 14.5 | 49.8 | 17.1 | 2.91 | 44 |
| Budd's Early | 63.0 | 2.295 | 14.34 | 74.0 | 8.9 | 17.1 | 43.2 | 15.0 | 2.89 | 41.7 |

| Name of Wheat. | % Moisture in Flour. | % Ash in Flour. | % OF NITROGEN IN | | | % Proteids in Flour. | % True Gluten in Flour. | % Gliadin in Flour. | Ratio Proteids in Wheat to Proteids in Flour. | Ratio between Proteids, Gluten, and Gliadin in Flour. |
|---------------------|----------------------|-----------------|------------------|---------|---------|----------------------|-------------------------|---------------------|---|---|
| | | | Flour. | Gluten. | Gliadin | | | | | |
| Kubanka | 11.65 | .974 | 2.940 | 2.360 | 1.252 | 18.36 | 14.75 | 7.85 | 1.15 | 100 : 72 : 125 |
| Budd's Early | 12.34 | .676 | 2.215 | 1.931 | 1.140 | 13.82 | 12.07 | 7.12 | 1.03 | 100 : 59 : 114 |

Potatoes.—Field crop of 3 acres—Blueskins and Brownell's Beauty. The latter variety has proved one of the best all-round potatoes to grow. This spring has not been the most favourable season, as late frosts were experienced which cut back the young growth, and did not give sufficient time for plants to establish themselves before hot weather set in. The photograph was taken eight weeks after planting.

Dairying.

THE TUBERCULIN TEST—IS IT DANGEROUS?

In his little text-book on "Milk and Milch Animals," Sir Walter Gilbey has shown that, at its best, the tuberculin test is of very doubtful utility. "It is well," says a correspondent of the "Live Stock Journal," "to consider the question whether it is not very dangerous, as well as being very unreliable. At the dairy show, a gentleman who has been connected with the London milk trade all his life expressed the conviction that the tuberculin test was almost entirely responsible for whatever recent spread of tuberculosis there had been in our dairy herds. 'I bought in fourteen cows three years ago,' he said, 'and all passed the tuberculin test before they went into my herd. After two years they were sold out, when they were all affected by tuberculosis, and I believe firmly that the tuberculin test two years previously planted the seeds of the disease in those animals.' This is one of the most startling statements in connection with the matter, if it should prove to be true, and ought certainly to be considered. We are told that the remedy for tuberculosis is to test the cattle with tuberculin, and get rid of those that react. But, if the test itself plants the seeds of the disease in the healthy animals, the results cannot be otherwise than disastrous. It would, therefore, be well if this important phase of an important subject could be thoroughly investigated."

We submitted this extract to Mr. Sydney Dodd, Principal Veterinary Surgeon and Bacteriologist to the Department of Agriculture and Stock, and he supplies the following comment thereon:—

Re your note of the 11th instant, and newspaper cutting as to whether tuberculin test is dangerous, I have to state that there is not a single case on record where it can be proved that a healthy cow has been injuriously affected by the tuberculin test when applied by an experienced observer. This charge against tuberculin has been settled for some years, but it appears to crop up periodically. When the stockowner considers what tuberculin is, and how it is prepared, he will see that any scare as to the danger of using it on a healthy beast is absolutely groundless.

The tubercle bacillus is grown for a number of weeks in broth. At the end of this period all the bacilli are killed by subjecting them to steam temperature. The broth is then mixed with a small percentage of carbolic acid and the whole filtered through a Berkfeld filter. It will thus be seen that it is impossible for even a dead bacillus to find its way into the filtered liquid which contains the broth, plus the products manufactured by the tubercle bacilli, and constitutes tuberculin, and it is, therefore, impossible for it to set up tuberculosis.

Tuberculin is a most valuable diagnostic agent for tuberculosis, but it is unfortunately not infallible. Animals which are in a very advanced stage of the disease sometimes do not show a reaction to tuberculin, and the diagnosis in these cases has to be based on a physical examination by the veterinary surgeon.

The testing by tuberculin is not merely an injecting of so much tuberculin into a beast, and the taking of one or two temperatures. If serious errors are to be avoided, the test must be conducted by an experienced person, as not only the actual rise in temperature must be considered, but what is more important, the *character* of the rise has to be noted. There are numerous other points to be observed in making the test, the neglect or inability to interpret correctly, any one of which, may completely nullify the value of it.

The indiscriminate use of tuberculin by the public has led to a good deal of shady work in connection with the test, and has resulted in some cases in discrediting it. It is known that an animal after it has had an injection of tuberculin will not react in the usual manner to a second injection for some weeks after, whether the beast is tuberculous or not. The consequence is, that unscrupulous stock owners or dealers have been known to inject their cattle with tuberculin a few days before it was to be tested for the buyer, the result being that the animal is not observed to react when the proper test is applied, and the buyer purchases a tuberculous beast, believing it to be healthy. Other cases have been known where men have been more alert than this in unlawful practice. In this case, just before the arrival of the veterinary surgeon; they will give the animal drugs which have the effect of lowering the temperature. The veterinary surgeon, if he is guided only by temperature indication, will find this normal, and may certify the animal free from tuberculosis, even though it is reacting at the time. But, as a rule, the experienced veterinarian is aided in forming his opinion by other symptoms shown by a reacting animal.

Other things to be considered by stockowners are—that tuberculin only shows that the disease is present, it does not cure, neither can it prevent an animal becoming infected, even on the day after it was tested; also, that a certain time, known as the period of incubation, elapses between the time an animal is infected and the time the disease begins to manifest itself on the animal body. Tuberculin injected between those two periods does not give any reaction at all, the consequence being that an animal may contract tuberculosis one week, and the next week be tested, yet it would probably show no reaction, and the animal be sold, quite honestly, as a healthy one. There is also the point mentioned above, that cattle in an advanced stage of tuberculosis, will sometimes give little or no reaction at all.

REGULATIONS UNDER "THE DAIRY PRODUCE ACTS, 1904 TO 1905."

Department of Agriculture and Stock,
Brisbane, 5th November, 1908.

The Lieutenant-Governor, acting as Deputy for and on behalf of His Excellency the Governor, and with the advice of the Executive Council, has, in pursuance of the provisions of "The Dairy Produce Acts, 1904 to 1905," been pleased to make the following additional Regulations.

W. T. PAGET.

Continuation of Regulations.

These Regulations shall be read and construed with the Regulations under "The Dairy Produce Acts, 1904 to 1905," published in the *Government Gazette*, dated 19th January, 1906, 20th October, 1906, 17th November, 1906, 22nd December, 1906, 2nd March, 1907, 28th March, 1908, 11th April, 1908, 13th June, 1908, and 15th August, 1908, respectively, and shall apply to the Cities of Brisbane, South Brisbane, Towns of Hamilton, Ithaca, Sandgate, Toowong, Windsor, Shires of Balmoral, Belmont, Caboolture, Cleveland, Coorparoo, Enoggera, Indooroopilly, Kedron, Pine, Sherwood, Stephens, Taringa, Tingalpa, Toombul, Wynnum, and Yeerongpilly.

Situation of piggeries and sanitary conveniences.

12. No milking shed shall be placed within one hundred and fifty feet from any piggery, earth closet, or cesspit.

Milking bails or sheds.

67. Every owner of a dairy shall cause the cow bails and sheds used in connection with such dairy to be covered with a roof that is weather-proof, and to be constructed at least seven feet in height above the floor level, and to be lighted and ventilated to the satisfaction of the inspector. He shall

cause the floor of milking bails or sheds to be formed of a durable non-absorbent material laid in such a manner as to be watertight, and graded with a slope to an open drain running the full length of the building, and of such a width as to be swept with a broom, and shall cause it to be continued to a distance of at least thirty feet beyond the confines of the milking shed or bail.

Manure.

68. Every owner of a dairy shall cause all liquid manure from the milking shed or bail to be drained into an impervious receptacle to the satisfaction of the inspector.

He shall cause all solid manure after each milking to be collected and conveyed to a distance of at least one hundred feet from the cow bail.

Animals other than milch cows, and stables.

69. Every owner of a dairy shall cause every stable and yard used in connection with the dairy to be well drained.

70. No owner of a dairy shall permit any animals, excepting milch cows, to be stabled or kept within fifty feet of a milking shed or cow bail or milk room, nor permit pigs to be at large on a dairy.

Poultry.

71. No owner shall keep fowls nor erect poultry houses within fifty feet of a cow bail.

Milkroom.

72. (a) Every owner of a dairy shall provide a detached room, to be constructed as hereinafter provided, of sufficient dimensions to be used for straining, cooling, or storing milk, or housing utensils used for containing milk, or in the collection or distribution of milk when such utensils are not in actual use.

(b) A milkroom shall be situated at least ten feet away from any milking shed.

(c) A milkroom shall be sufficiently lighted and ventilated, and all openings shall be protected with a fly-proof wire screen of No. 16 mesh wire, and the doors shall be so hung as to be self-closing.

(d) The floor shall be covered with non-absorbent material (to be approved by an inspector) properly set in cement, and laid so that the lowest part of its surface is at least six inches above the adjoining ground. Such floor shall be on a solid, sound foundation, with a proper slope to an impervious channel, which shall communicate with a suitable trapped drain outside the building, or to an approved receptacle situated at least ten feet from the room and from the milking shed or bail. The surface of the floor shall be finished so that it will afford no lodgment for dirt or for liquid. The roof and walls shall be so constructed and finished as to afford no lodgment for dirt.

(e) No dog, cat, fowl, or other domesticated animal or bird shall be allowed to have access to such room.

Utensils, &c.

73. (a) An apparatus to be approved by an inspector shall be provided by every owner of a dairy for the purpose of heating water for cleansing utensils, &c., and shall be placed in a position approved of by an inspector.

(b) Apparatus for cleansing utensils shall not be used for any other purpose.

Lime-washing.

74. The owner of a dairy shall cause all milking sheds and bails to be lime-washed at least every six months and at such other times as may be required by the inspector, providing that this requirement shall not apply to any part of such ceiling, roof, or walls that may be properly painted or varnished, or constructed of or covered with any material such as to render the

SKETCH PLAN FOR MILKING SHED AND MILK ROOM

AS REQUIRED BY REGULATIONS

3/16 INCH SCALE

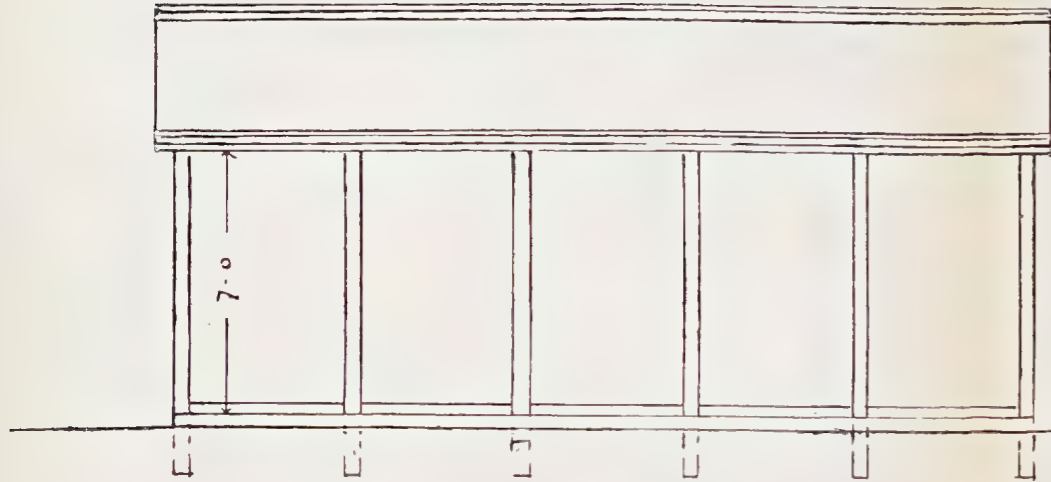

FRONT OF BAILS

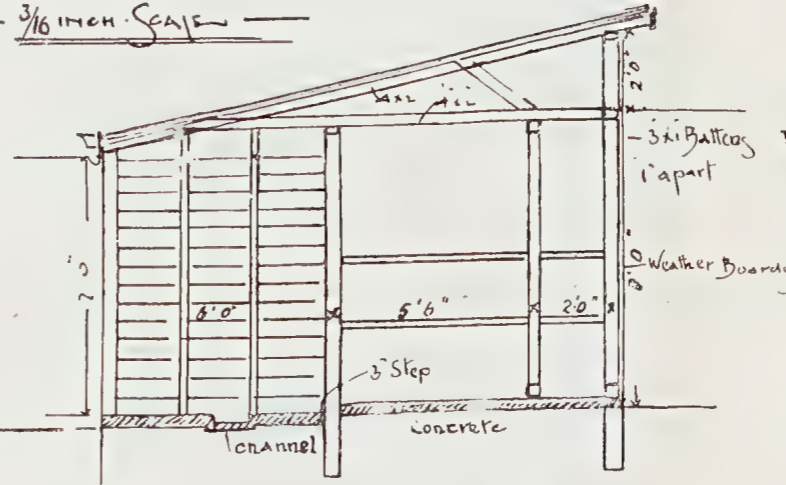

SECTION OF BAILS

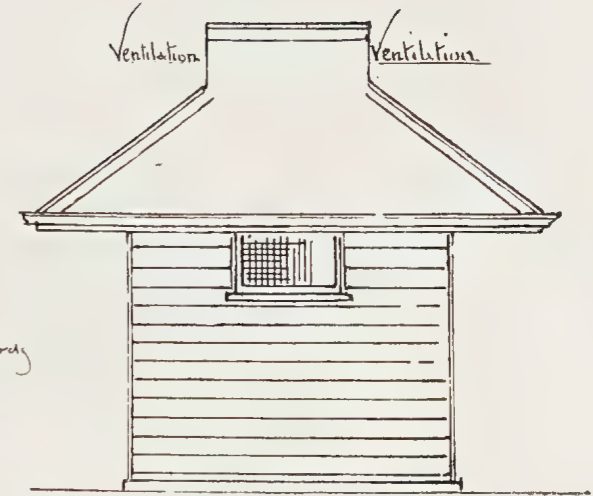

SIDE OF MILK ROOM

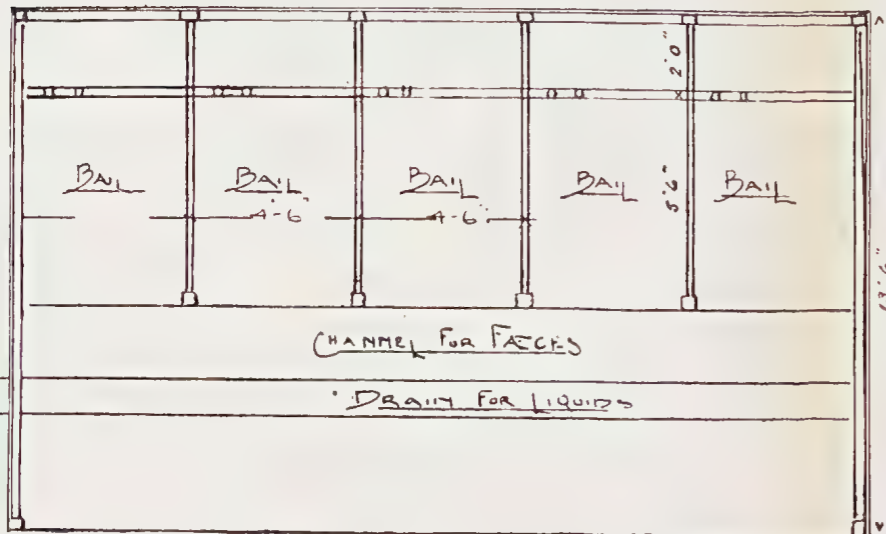

PLAN OF MILKING SHED

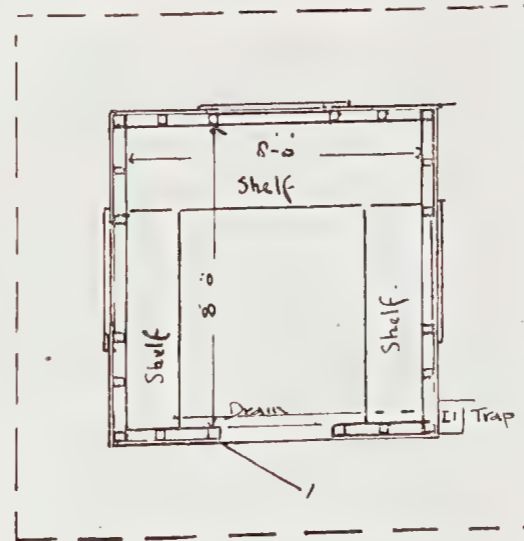

PLAN OF MILK ROOM

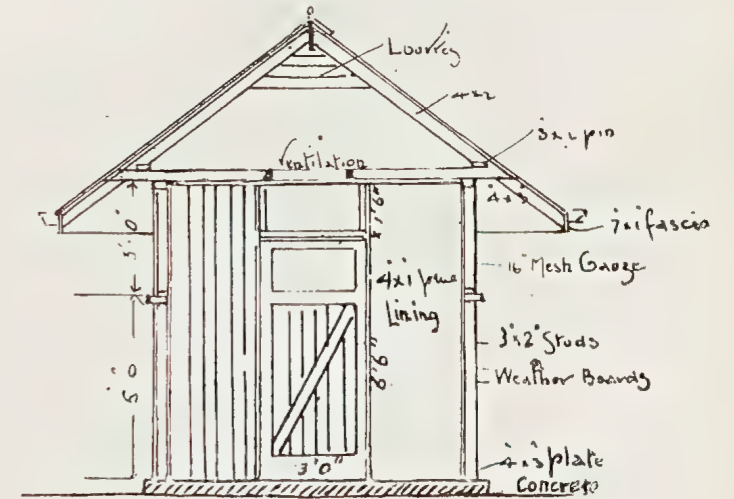

SECTION OF MILK ROOM

lime-washing unsuitable or inexpedient, and that may be otherwise properly cleansed. The owner shall cause the floor of every milking shed to be thoroughly swept and cleansed, as often as is necessary, to ensure that such cowshed shall at all times be reasonably clean. He shall whenever required by an inspector disinfect his milking shed or any other building on his premises in a manner and with such materials as directed by an inspector.

Unwholesome food.

75. No owner of a dairy shall feed or permit to be fed to his cows any musty, unsound, decayed, or unwholesome food which may injuriously affect the milk or health of the cows, and if an inspector has reasonable grounds for supposing that any cattle food on the premises is unsound or unfit for use as food, he may require the keeper to remove such food from the premises and refrain from using it for dairy purposes.

Water supply.

76. (a) An owner of a dairy shall keep in connection with a dairy an abundant supply of wholesome water. Dairy cows shall not have access to impure water, rubbish, or refuse.

(b) He shall cause any tank or other receptacles which may be provided for storing water to be emptied and cleansed from time to time as often as may be necessary to prevent the contamination of any water that may be stored therein.

Inspection.

77. If, after the inspection of the stock in any dairy, an inspector is of opinion, or has reason to suspect, that any of such stock are diseased, he may, in writing, order the owner of the dairy to draft out and keep isolated all such diseased or suspected stock from the stock not suffering from disease. The inspector shall report all animals infected or suspected of being diseased in accordance with the diseases in the First Schedule to "*The Dairy Produce Act of 1904*," and if the Minister is satisfied the animals are infected and orders the same to be destroyed, they shall be destroyed. Milk or other dairy produce from time to time obtained from such diseased or suspected stock shall be destroyed. Such owner shall forthwith obey such order and shall continue to keep isolated all such stock, and from time to time destroy or otherwise deal with such dairy produce until the inspector otherwise orders. He shall, if so required by an inspector, tag, or brand, or otherwise mark any isolated animal for the purpose of identification.

Use prohibited.

78. The owner of a dairy in which there are diseased stock, or in respect of which an inspector has made an order of isolation, shall not, until the inspector permits him to do so, mix the milk or other dairy produce from time to time obtained from any diseased or suspected stock with other dairy produce, or sell, or expose for sale, or use, or cause or permit to be sold, exposed for sale, or used, the same in any way whatsoever for the food of man or of any animal, nor shall he permit such milk to be used for the food of animals until it has been boiled.

Penalty.

79. Any person committing a breach of any of these Regulations shall be liable to a penalty not exceeding ten pounds.—*Government Gazette*, 7th November, 1908, pages 959-60.

ANGORA GOATS.

Angora goats have been found particularly useful in Wairoa, a district in the North Island of New Zealand, as destroyers of the blackberry. Portions of the country, which a few years ago were "an impenetrable mass of this, perhaps the worst of all noxious weeds," have now been raised to the

carrying capacity of two sheep to the acre, thanks to the introduction of the Angora goats. They are particularly fond of the foliage and young shoots of the plant, and have literally cleared large areas of land. They show an aversion for any kind of grass, preferring coarser herbage; this preference has its drawbacks, as was found by a farmer who turned a few into a field of rye grass; the goats ignored the pasture, but nearly ate their way through the surrounding hedges. [What other results could have been expected?—Ed. "Q.A.J."]

Another objection to the Angoras is that they are difficult to muster, being very active, preferring rough ground, and being addicted to scattering in all directions as soon as a horseman or dog appears in sight. Each goat takes up its position on the most inaccessible site it can find, and stands on the defensive, defying dog and man. This habit makes the task of collecting them a heart-breaking one, and is said to completely ruin good sheep dogs, which are accustomed to more docile charges. The valuable fleece also is troublesome to shear; their coats are beautifully clean and free from foreign matters from skin to tip, but there is no yolk in the hair, and this compels the shearer to stop continually and oil his machine while taking the coat off a single animal. Very fine examples of the Angora in Australia have given as much as 16 lb. of hair, which fetches 4s. 6d. per lb., a total of £3 12s. for the fleece. This being the case, it is not wonderful that the Angora is receiving attention in New Zealand.—"Live Stock Journal."

For the illustrations of South African Angoras here given we are indebted to the courtesy of Messrs. Dalgety and Co., in whose excellent "Monthly Review" for December they came under our notice.

They show, says the "Review," the advanced state to which the breeding of Angora goats has attained in South Africa. The Hobson family of the Graaff-Reinet district, Cape Colony, are the leading South African breeders, and the big weights, combined with the all-round excellence of their Angoras, demonstrate unmistakably how they have succeeded in improving the animal by careful and scientific breeding. The importance of the mohair industry in South Africa is illustrated by the value of the annual export of mohair from Cape Colony, which amounts to no less a sum than £600,000 per annum. The whole of the production is practically exported to England, and manufactured in the great wool centre, Bradford.

That the South Africans are desirous of keeping their industry a close monopoly is shown by the fact that the Cape Parliament in recent years placed a prohibitive export tax on Angoras of £100 per head. Whether this policy will prove beneficial to them time will prove, as the United States of America has a large and growing industry, and no restrictions are placed on their export there, several stud Angoras having already been introduced into Australia from that quarter, individual fleeces cut from them and their progeny weighing up to 10 lb. per head.

No doubt it will be many years before Australian breeders can hope to produce animals equal to the best of South Africa, but many large undertakings have sprung from small beginnings, and let us hope this will be the case with the Australian Angora goat industry, the foundation of which is now being laid, as the following figures in reference to last year's shipment of mohair from New South Wales and Queensland show—viz., 3 tons, of a value of £250.

The prices realised for the principal lines will no doubt be read with interest, being a guide to current values.

REALISATION OF MOHAIR IN LONDON, 1908.

From New South Wales.

| | Per lb. | |
|--------------------|---------|--------------------------------------|
| Fleece, unskirted, | 14½d. | ... Buckland, J. A., Gulgong |
| " " | 13½d. | ... Blaxland and Knox, Wyalong. |
| " " | 12½d. | ... Martin, Geo. H., Wentworthville. |



ANGORA RAM, PRIDE.



Plate XVI.

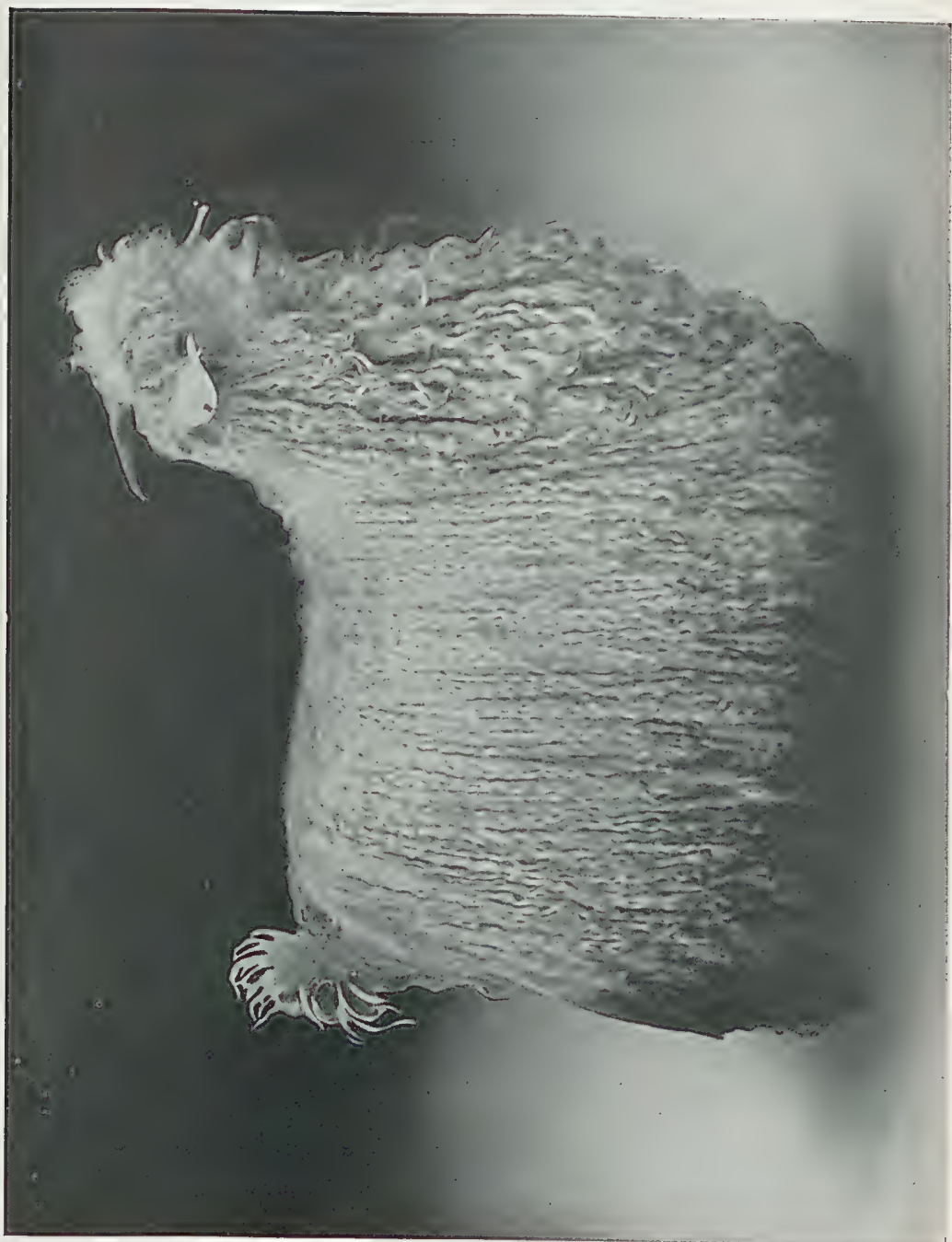

ANGORA EWE, MAUD.

| | | | |
|--------------------|---------------------|---------------------|-----------------------------|
| Fleece, unskirted, | 12 $\frac{1}{2}$ d. | ... | Failes, Dr., Coonabarabran. |
| " | " | 10 $\frac{1}{4}$ d. | Mitchell, Geo., Wagga. |
| " | " | 9 $\frac{3}{4}$ d. | Poole, Willm., Bathurst. |
| " | " | 8 $\frac{1}{4}$ d. | Kemp, A. F., Manilla. |
| " | " | 7 $\frac{1}{2}$ d. | Allan, Geo., Manilla. |

From Queensland.

| | | | |
|--------------------|---------------------|---------------------|--|
| Fleece, unskirted, | 14 $\frac{1}{2}$ d. | ... | Price, A., Pickanjinie. |
| " | " | 11 $\frac{1}{4}$ d. | Green, Jas., Yeulba. |
| " | " | 9 $\frac{1}{2}$ d. | Roberts, C., Mitchell. |
| " | " | 9 $\frac{1}{2}$ d. | Bassingthwaite, Jandowaie. |
| " | " | 9 $\frac{1}{2}$ d. | Simpson, G. H., Torrington, Toowoomba. |
| " | " | 9 $\frac{1}{4}$ d. | Jackson, W., Yelton, Byrnestown. |
| " | " | 8d. | Myles, Miss, Mt. Elsie, Charters Towers. |
| " | " | 7 $\frac{1}{2}$ d. | Wilson and Symons, Semla. |
| " | " | 7 $\frac{1}{2}$ d. | Lonergan, F. and L., Bowenville. |
| " | " | 6 $\frac{3}{4}$ d. | Hampson, C., Gowrie rd., Toowoomba. |
| " | " | 6 $\frac{1}{2}$ d. | Olsen, P., Clermont. |
| " | " | 5 $\frac{1}{2}$ d. | Mathieson Bros. |

The word "mohair" is the technical name for the fleece of the Angora. Mohair differs from the wool of sheep in that it does not have the felting properties of the latter. It is this felting property of wool which distinguishes it principally from other animal fibres. Mohair is a hair proper, being devoid of scales, and so is not successfully used alone in felt goods. It is not equal to wool in fineness, but in breaking strain there is a considerable difference in favour of mohair. It is to this strength of the fibre that the great durability of mohair goods is ascribed.

In elasticity there is but a slight difference between wool and mohair. All mohair has a lustre peculiarly its own, being much more pronounced in some fleeces than in others. A fleece of low lustre indicates a goat under low conditions, as poor breeding, poor feeding, or sickness.

A mohair fleece may be washed, scoured, steamed, dyed, and worked up into fabrics, but none of these processes remove any of the lustre; indeed, all of them operate only to intensify them.

The three leading features of the mohair staple are—strength, length, and lustre. Mohair manufactures have already a very extensive use, but they appear in the stores under so many trade names that only a few people know they are the product of the Angora goat. These manufactures are so varied, and the fibre adapted to so many uses, that only a recital of some of the principal uses of mohair can be given here, but these will serve to show how extensive is their use at the present time. Plushes for upholstering railway carriages and furniture, ladies' lustre dress goods, and alpaca goods are chiefly made from mohair; wig-making also consumes a large quantity of mohair.

PRIDE.

Ram, as at 18 months, cut 11 $\frac{1}{2}$ lb. mohair in 13 months. One of first prize pen at Grahamstown, 1903. Registered No. A103 S.A. Stud Book. Second prize at Grahamstown and Port Elizabeth, 1905, when he cut 19 lb. hair in 12 months.

MAUDE.

Taken when 18 months old, with 13 months' growth of hair; cut 9 $\frac{3}{4}$ lb. Second prize Grahamstown, 1903; first prize, Grahamstown and Port Elizabeth, 1904; first prize, East London, 1906; second prize, Port Elizabeth, 1906; first and champion, Capetown, 1907; second prize, East London and Port Elizabeth, 1907. Registered No. AB696 in S.A. Stud Book.

THE DAIRY HERD, QUEENSLAND AGRICULTURAL COLLEGE,
GATTON.

RECORD OF COWS FOR MONTH OF DECEMBER, 1908.

| Number. | Cow's Name. | Breed. | Date of Calving. | Total Milk. | Average Test, Per cent. | Commer- cial Butter. | Remarks. |
|---------|-------------------|--------------------|------------------|-------------|-------------------------|----------------------|------------|
| | | | | Lb. | Lb. | Lb. | |
| 1 | Pee wee ... | Holstein-Sh'rth'rn | 20 May, 1908 | 899 | 4.4 | 44.40 | |
| 2 | Laura ... | Grade Shorthorn | 16 Nov. " | 1,077 | 3.6 | 43.08 | |
| 3 | Whitefoot ... | Holstein-Devon | 20 Oct. " | 992 | 3.5 | 38.50 | |
| 4 | Daisy ... | Holstein ... | 24 Oct. " | 915 | 3.5 | 35.51 | |
| 5 | Dewdrop ... | " " | 10 Nov. " | 964 | 3.3 | 35.14 | |
| 6 | Dora ... | Grade Shorthorn | 18 Nov. " | 885 | 3.5 | 34.34 | |
| 7 | Dot ... | " " | 12 Nov. " | 868 | 3.3 | 31.64 | |
| 8 | Comet ... | " Holstein .. | 22 Nov. " | 792 | 3.5 | 30.73 | |
| 9 | Sue ... | " " | 25 May " | 701 | 3.9 | 30.51 | |
| 10 | Carrie ... | Jersey ... | 16 Jan. " | 792 | 3.5 | 30.73 | |
| 11 | Cocoa ... | " " | 10 Nov. " | 569 | 4.7 | 30.11 | |
| 12 | Wonder ... | Grade Shorthorn | 1 Dec. " | 713 | 3.6 | 28.52 | |
| 13 | Burton's
Fancy | Shorthorn ... | 7 Sept. " | 496 | 5.0 | 27.99 | First calf |
| 14 | Ethel ... | Grade Shorthorn | 3 Sept. " | 720 | 3.5 | 27.94 | |
| 15 | Eve ... | Jersey ... | 16 Oct. " | 620 | 4.0 | 27.71 | |
| 16 | Lily ... | Ayrshire ... | 2 May " | 496 | 4.8 | 26.83 | |
| 17 | Graceful ... | Jersey ... | 10 Dec. " | 598 | 3.9 | 26.01 | |
| 18 | Grace ... | Shorthorn ... | 30 May " | 614 | 3.6 | 24.56 | |
| 19 | No. 112 ... | " " | 24 Nov. " | 651 | 3.4 | 24.49 | |
| 20 | No. 1 ... | " " | 1 Nov. " | 682 | 3.2 | 24.06 | |
| 21 | Nancy ... | Grade Guernsey | 7 May " | 583 | 3.7 | 23.99 | First calf |
| 22 | Lubra ... | " Holstein... | 5 Jan. " | 534 | 4.0 | 23.86 | First calf |
| 23 | Careless ... | Jersey ... | 3 Dec. " | 558 | 3.8 | 23.61 | |
| 24 | Lark ... | Ayrshire ... | 6 Jan. " | 558 | 3.8 | 23.61 | First calf |
| 25 | Len ... | " " | 6 Mar. " | 558 | 3.8 | 23.61 | |
| 26 | Lady Loch | " " | 24 June " | 527 | 4.0 | 23.55 | First calf |
| 27 | Nita ... | Grade Shorthorn | 23 Nov. " | 620 | 3.4 | 23.33 | |
| 28 | Glen ... | Shorthorn ... | 10 Feb. " | 403 | 5.0 | 22.74 | |
| 29 | Night ... | Grade Holstein... | 5 Oct. " | 682 | 3.0 | 22.45 | |
| 30 | Lalla ... | " " | 28 July " | 560 | 3.6 | 22.40 | First calf |

Cows were fed on natural pasture only.

TO CRYSTALLISE FRUITS.

The following method of crystallising fruit is given in the "Agricultural Journal" of the Cape of Good Hope (July, 1908):—

The means of preserving fresh fruits in a crystallised form is attained by extracting the juices from the fruits and replacing them with sugar syrup, which, upon hardening, preserves the fruit from decay, and at the same time retains their natural shape, and, to some extent, flavour. The process is as follows:—Fresh fruit, nearly ripe, whole, or cut into quarters, in the case of citrus and such large sorts, should be boiled until they are soft enough to be handled without breaking. In the case of citrus fruits, the rind should be lightly pared off, and the pulp removed, at least a couple of hours before boiling. The softer kinds, such as peach, plum, apricot, &c., would merely be steeped in boiling water for a very short time, care being taken that they are not immersed sufficiently long to be cooked. The exact time can only be determined by actual experience. After this, the water from the fruit should be allowed to drain off thoroughly, and, when sufficiently dry, they should be placed in hot sugar syrup, and kept there for a few days, so that the sugar may enter the fruit cells and displace what juice remains after the boiling or scalding process. The fruit should then be lightly washed in clean cold water, and packed in dry white sugar while wet, and allowed to remain there and dry off in a draught, until it is hard enough to be packed away for transport. A common home recipe for preparing sugar syrup is:—1 lb. white sugar to 1 pint of water, adding the white of an egg to every 4 lb. of sugar; boil this mixture over a fast fire for twenty minutes, and strain through a cloth while hot, when it is ready for use.

The Horse.

CLIPPING HORSES.

In our issue of December, 1908, we published a short article on clipping horses, in which it was recommended that, with well-fed horses, the hair should be left on the extremities, and also on parts liable to be much worn by harness. Young beginners are desirous of advice on this point, which, however, it is not always easy to give, unless one has personal knowledge of the class of animal in question and the amount of work he is accustomed to. A writer in the "Live Stock Journal" on clipping or singeing horses says:—

"With regard to hunters, of course there is no question as to the advisability of clipping them, or at least the greater portion of the surface of the body, but in some animals, especially those with a "thin" or irritable skin, it is better to leave the saddle mark and the lower parts of the limbs unclipped, with a view of preventing sore backs and that form of skin eruption commonly known as "mud fever."

"Heavy draught horses doing only walking-pace work are, as a rule, best left with their full coats on, but the question frequently arises as to whether or not heavy van horses, or horses that are sufficiently substantial to be termed cart horses, but whose work is chiefly long-distance road work at a slow pace, such as millers' brewers', timber-haulers' horses, should have any part of their coats removed, and if so, to what extent, and which parts should be clipped, and which left with the coat on.

"Some persons are great advocates of clipping the limbs and abdomen, removing the coat about trace high in such animals, but, in my opinion, this practice has a serious objection to be raised against it, because, while undoubtedly allowing the horse so clipped to move with somewhat more freedom, and facilitating the removal of dirt, &c., it certainly renders the animal more susceptible to cracked heels, mud fever, and internal congestive diseases of the abdominal organs, and probably of the lungs too, unless great care is taken to protect these parts—that is, the clipped parts—from cold draughts, particularly when they are damp. One point respecting the clipping of horses' legs is, I think, well worthy of notice, and this is, that it is a fact that horses that have become somewhat "stale" on their legs during the summer months actually improve if their legs are clipped while working through the winter. This is due to the stimulating action of cold air on the skin of the limbs, to which it has free access by the removal of hair.

"Very similar remarks apply also to the middle class or tradesmen's horses, for it may be taken that, as a rule, unless the horse has a fine coat naturally, or it is impossible to prevent undue exposure to cold and wet, it is best for the health and comfort of the animal to remove the coat, providing it is done fairly early in the season and a reasonable amount of artificial protection is substituted when the horse is not at work or being in any other way exercised."

HORSES NOT LYING DOWN.

Cases not infrequently occur of stabled horses acquiring the habit of not lying down to sleep at nights, but remaining standing up in their stall. This habit is a most objectionable and, in fact, a most harmful one, because it prevents the horse from obtaining proper rest, and that, as may readily be imagined, tells adversely both upon the animal's condition and upon its working capacities. The legs also suffer very considerable harm when a horse gets into the habit of never lying down, since they are never relieved of the

weight of the body, but have to support it in the night-time as well as during the day. Thus they are subjected to an unintermittent strain which tends to wear them out prematurely. For a horse always to remain standing and never to lie down is, of course, an entirely unnatural habit. To break the animal of it once it has become firmly established is at best very difficult and oftentimes practically impossible. Various causes may give rise to this unfortunate and harmful stable habit, by far the most common undoubtedly being stiffness of joint resulting from age. Thus some old horses habitually refrain from lying down at night, or in the daytime either, because, owing to their being somewhat stiff in their joints, it proves irksome and troublesome to them to lie down and get up again. Rather than make the special efforts which in their case lying down and rising up involve, they prefer to remain standing, and to sleep in that uncomfortable position. In this way they gradually get into the habit of sleeping while standing; and the longer they continue in it, the more firmly established does it become, until finally nothing will induce them to lie down in the stable. Sometimes the only reason why a horse will not lie down at night is that its stall is unduly narrow, so that the animal cannot move about sufficiently, preparatory to lying down. Horses are very commonly somewhat fidgety when they are about to lie down, and like to have plenty of room to move about in when doing so. Hence it will in some instances happen that a horse, on finding its freedom of movement too much restricted by the extreme narrowness of the stall on attempting to lie down, will not do so, and in this way he gets into the habit of remaining in a standing position overnight instead of lying down. In such cases the evil can generally be easily remedied by placing the animal in a roomier stall or, better still, in a loose box, if this is available. On finding itself in more roomy quarters where it has more freedom of movement, the horse will readily lie down.

When young horses are taken up into the stable and stood in a stall for the first time, it not infrequently happens that they refuse to lie down for the first few nights, because, after enjoying complete liberty, they are unaccustomed to such cramped quarters and to having their freedom of movement so much interfered with by being tied up by the head. This naturally makes them feel very awkward at first when attempting to lie down, and may render them altogether disinclined to do so. When a young horse thus at first refuses to lie down, it usually adapts itself to the new conditions sooner or later, and learns to lie down in its stall in the natural course of events, so that no anxiety need be felt when the animal refrains from lying down for the first few nights.

Sometimes—though this happens but comparatively rarely—the habit of not lying down at night-time is acquired by a horse as the result of its having been cast in its stall. This awkward accident—particularly if the animal in question is of a nervous temperament—may frighten it so greatly and remain so impressed upon its memory—horses have a most retentive memory, particularly for disagreeable things—that for the future it is afraid to attempt to lie down for fear of a similar accident befalling it. When a horse acquires this objectionable habit in the manner just described, it may be that under favourable conditions the animal will in the course of time forget about its aversion to lying down, and lose the trick again without any special measures being taken, but more likely than not, once the horse has got into the habit of remaining standing up at nights as the result of being cast in its stall, it will continue in it, unless some special means are adopted to break it of the same.

In seeking a cure, the first remedy is to place the horse in a loose box if one is available, the animal, of course, being left loose, so that it can move about therein at will. The roomier the loose box is the better. Though it may be averse to lying down in a stall, and when its head is tied up (under which conditions its movements are so greatly interfered with and restricted),

the horse, on being accommodated in a loose box, will very usually lie down readily enough on finding that it enjoys complete freedom of movement and can turn about as much as it likes. A deep bed of straw should also be provided, as a plentiful supply of litter will be a further inducement to the horse to lie down. Once the animal has learned to get down again, it will continue to do so, and it will thus quickly lose its habit of remaining in a standing position at nights. Should a loose box not be available, the horse may be quartered in an empty barn or in a coachhouse—the kind of accommodation matters little, the essential thing being that the horse should enjoy ample room so that it can turn about at will, and that it should not be tied up. Given these two conditions, it will be found in the majority of cases that horses which have got into the habit of not lying down in a stall will speedily lose it again. It will, of course, not do to transfer them back to a stall for some considerable time after they appear to have been cured of their bad habit, because on the horse once more being placed in circumscribed quarters, and having its head tied up, the old trouble will most probably recur. The horse must be left in the loose box or other roomy quarters for a long time, so that it may quite forget about its former habit of not lying down.—“Live Stock Journal.”

GLENTHORNE MONARCH.

The fine Suffolk Punch stallion, Glenthorne Monarch, illustrated on the next page, was purchased in Adelaide from the Hon. George Brookman, M.L.C., O'Halloran Hill, and arrived here in December, 1908, being then sent on to the State Farm, Gindie.

He is a fine chestnut horse, with blaze, two years old, active and docile, a characteristic of this excellent breed of farm horse.

His pedigree is thus given in the British Suffolk Stud Book, vol. 16:—Glenthorne Monarch, 3444, foaled 30th September, 1906; sire, Rendlesham Collegian, 3175; dam, Rendlesham Snowdrop, 8087, by Toller's Oberon, 2778.

Glenthorne Monarch took first prize as a two-year-old at the last Adelaide show.

He arrived at Gindie in splendid condition after his long journey by sea, rail, and land from Adelaide to his destination.

FORESTS OF JAPAN.

Fifty-nine per cent. of the total area of Japan is under forests—that is to say, that forests cover 58,000,000 acres of the country. Of this area the State owns 33,000,000 acres, the Crown nearly 5,250,000, municipalities over 4,250,000, shrines and temples nearly 500,000, and private owners nearly 15,000,000 acres. Yet Japan imports more timber than she exports. The exports are represented by £250,000 worth of timber and £850,000 worth of wooden matches. The net revenue from the State forests is £1,600,000 per annum, an increase of 16 per cent. in the past twenty years.

The making of tea chests has long been one of the industries of Japan, but the timber of which the momi tea chests are made, and which later for many years have been in great request, is becoming increasingly scarce, and there has been a very great shortage of Japanese chests in India. As regards the import of timber, in 1907 the imports of log timber and planks to the open ports of Auping and Takow, in South Formosa, amounted in value to £69,250. Japan in the same year imported timber to the value of £235,400. and exported £396,935 worth.

Poultry.

THE MARKETING OF POULTRY.

The Board of Agriculture and Fisheries, London, has issued the following leaflet (No. 201) on the marketing of poultry, which will, at this season, prove of much interest to prospective shippers of poultry from Queensland to London:—

The demand for high-class poultry in Great Britain has very greatly increased in recent years, and, even apart from the growth in the population, there appears to be ample room for extension in the home supply. Even in those markets where the chief business is in unfattened specimens, a steady increase in the sale of finer quality fowls is evident. As their greater value is appreciated by consumers, it may be anticipated that the demand for these will grow. The object of most producers should be to provide for this better class trade. American, Russian, and other Continental supplies are frozen, and do not enter into very serious competition with freshly-killed British poultry if of suitable breeds and well finished.

MARKETS.

London.—The best markets in the country are those of Leadenhall and Smithfield, in London, but to obtain good prices the birds sent up must be very carefully fed and well finished. Overstocking of these markets with the very best quality of fattened birds is hardly likely to occur, and for birds of 4 to 5 lb. and over, according to the season of the year, there is a ready sale. Where disparities in prices in the same consignment occur, it will frequently be found to be due to variation in size and quality. During the spring there is a good demand for young chickens, weighing 2½ to 3 lb., unfattened but well fed, and a more limited sale of milk chickens, weighing about 12 oz.

In the London markets the best season for large, well-fattened fowls is from November to February, and from March to July for moderate-sized birds. Ducklings sell fairly well all the year round, but best from February to June; there is a fairly good demand for fat ducks in the autumn and winter; goslings in May and June, and at Michaelmas; fat geese at Christmas and for a short time afterwards, but their season is limited: turkeys fetch high prices, according to size, appearance, and straightness of breast bone, at and for a very short time after Christmas. As to days of the week at Smithfield (Central Market), Tuesdays, Thursdays, and Fridays are best: at Leadenhall, Mondays, Wednesdays, Thursdays, and Saturdays.

Provincial Markets.—Information as to demand, prices, &c., in a large number of the best markets outside London will be found in the "Journal of the Board of Agriculture" for February, 1908, p. 641, and May, 1908, p. 94.*

KILLING.

All birds should be starved for twenty-four hours before killing in order that the crop and intestines may be emptied of food. A great amount of loss arises from neglect of this precaution. They should be killed by dislocating the neck just where it joins the head, unless the purchaser wishes them to be killed in a special way. Some salesmen like them to be bled by a knife passed through the slot in the roof of the mouth, but this is required in only a few cases. Bleeding is apt to spoil the feathers and soil the packing,

* The Journal may be obtained from the Offices of the Board of Agriculture; price, 4d. per month, post free.

and this will reduce the price of the whole consignment. Dislocation of the neck, properly performed, results in the breaking of the jugular vein, and the blood drains completely from the body veins into the neck.

PLUCKING.

Birds should always be plucked while the body is still warm, as the feathers then come out more easily, and there is less danger of tearing the skin. Except among the poorer class of buyers, a badly-plucked bird is of but little value. Unless plucking is done when the bird is warm, it should not be done until the bird is quite cold—that is, at least twenty-four hours after killing.

In plucking, the operator should hold the bird by the legs, with the head hanging downwards, or in the case of turkeys and geese suspend it by the legs to a cord hung from the roof. Feathers are drawn by a firm yet gentle pull towards the head, this action loosening them from the skin.

The plucking should begin at the tail and be continued in the following order:—Back, neck, wings, sides, legs, and breast. It is unwise to start with the breast, as the surface veins in that part of the body are the last to drain dry, and the carcass will be discoloured if any of these veins are broken. The breast bone should not be broken.

Fowls must be plucked clean, except for the head and half the neck; turkeys must also be plucked clean, but leaving the feathers on the outer ends of the wings and the tail; in ducks and geese the wings and half the necks must be left unplucked.

The legs and feet of all birds should be very clean.

SHAPING.

When quite clean, chickens should be singed and packed tightly, breast downwards, in a shaping trough, with the heads hanging over the front board, and left in this position for the flesh to set and cool. A long narrow board should then be placed along their backs, and the board weighted, a common method being to use a 9-lb. brick to every two birds. In placing the birds in the trough, the stern is pushed hard up against the back board, thus giving the birds a shortened appearance. Shaping troughs are usually made to hold eight or twelve birds.

For some markets the birds are required to be tied down in Devonshire fashion. This is done as follows:—

Immediately after plucking the back, the claws are removed and a gash is made on each side of the middle toe. A short string is then tied to each of these toes, the legs are drawn forward and inwards, and the two strings are tied together behind the neck, and pulled tight. A second and rather longer string is now tied round the hocks, crossed on the vent, and fastened at the back of the tail, again pulling tight. Finally, the wings are tucked in, and the bird will be ready for packing directly it is quite cold.

Ducks and geese have the wings turned, and are usually weighted, thus compressing them into a good shape. This must be done when they are warm, otherwise they do not set properly.

Turkeys are tied down in the way described as the Devonshire fashion for chickens, or in the Norfolk fashion.

GRADING AND PACKING.

A most essential point is that all poultry should be quite cold before they are despatched. On large plants a chilling chamber is found most useful, but in the absence of this they should be allowed to remain for some hours in a cool room, until the body heat is entirely gone.

The question of the grading of poultry is also of great importance. It is very desirable that only birds of about the same size should be packed

together, but if those of different sizes must be placed in the same package they should be arranged in layers, and the fact that they are so packed should be stated when advising buyer of despatch. The sizes may be 3 to 3½ lb., 3½ to 4 lb., 4 to 4½ lb., and 4½ lb. to 5 lb. It is advisable that separate pads, baskets, or boxes should be used for different sizes, each box being marked with a distinctive brand and clearly showing the number and size of the birds. In Surrey it is the practice after the chickens have been shaped for them to be floured and packed in specially made crates called "pads," which are of different sizes, and hold respectively twelve, sixteen, twenty, and twenty-four birds.

Ducks, geese, and turkeys should be sent in baskets or strong crates, with the number and actual weight of the contents marked on one end outside.

In packing poultry the birds are laid breast downwards on clean straw, and packed as tightly as possible to prevent them shifting while on rail. Clean butter paper is, by the best packers, placed between each layer of birds to prevent the straw marking the backs and rubbing off the skin. Though this means a few more minutes per package, it brings a more ready sale, and is an excellent practice.

FORWARDING.

A postcard should be sent to the buyer or salesman telling him by what route and train the crate will travel, and mentioning by what mark he will be able to identify the crate.

The crate should travel by an evening train, in order to reach the market in the very early morning, and it should be consigned at dealers' rates. In warm weather the birds are less likely to be heated if they travel by night.

GENERAL.

There is a growing demand for goslings weighing from 6 to 8 lb. during the London season—from the middle of May to the end of June. Goslings sold then are off the ground before keep becomes valuable for other farm stock.

Fowls should not be drawn when sent to the markets, but some buyers prefer them to be "roped"—that is, to have the intestine drawn out at the vent, leaving the rest of the inside intact, during the hot months. This is frequently done in the Midlands and Ireland. Unless the distance from the market is considerable, the birds are unpacked and sold within a few hours of despatch, so that this practice is not generally necessary except in hot weather.

It is the custom on farms to keep old hens long after they are really profitable from a breeding or laying point of view. A hen is rarely worth her keep after the conclusion of her second year. But these are in demand at Easter, in June, and early July, when good prices are paid by Jewish dealers. They should be in good condition, and be sent alive.

COMMON SENSE IN THE POULTRY YARD.

I do not claim, says S. Gordon, in the New South Wales "Farmer and Settler," that what I have to say will be couched in language that will gain me any reputation as a literary man, but I do know that, as it is the outcome of twenty years' experience, it is not likely to be far wrong from a practical standpoint, and may be of great benefit to farmers who are either keeping poultry for the first time or are beginning to take an interest in their old flocks on the farm.

I have been working along the same lines, as I say, for twenty years; and I am, therefore, likely to know more about the subjects I write of than the mushroom men who spring up from time to time; nevertheless, I am

quite prepared to take up any new idea worth attention, just as a farmer will grow a new crop or raise a fresh class of stock if the prospects are promising.

To be a successful poultry farmer you must have a knowledge of the business, just as to succeed in any other vocation you must be acquainted with the rules governing it. If you have not the requisite knowledge and experience to-day, there is no reason why you should not get it if you are built that way. If not, do not touch poultry farming, for you will only be inviting failure. For a man to try to raise poultry who is cut out by Nature for a musician is to court disaster.

I will try to show you the right way to start.

You must have your houses before your fowls; therefore the first thing is to choose your site. The fowl-houses and runs must be on high ground—the higher the better—and if you attend to this you will not have many sick hens. Do not spend a lot of money on fowl-houses; build of whatever is handiest and cheapest. And as to the architecture of the fowl-house, one style is pretty well as good as another. The important thing is that they should face the north, and be open at the front, with closed sides and back. See that there are no cracks, the ventilation being provided by an open 6-in. space immediately under the roof at the back and along the sides. Raise the floor above the level of the yard, and put in the roosts 2 ft. from the floor all on one level.

To prevent cats or other pests from gaining admittance you may close the front with wire-netting and a netted door; covering also the 6-in. ventilation space.

I want to impress upon you that this is a roosting-house only, and must not have any nests in it.

If you have many layers you will require to build a separate nest-house and scratching-shed, but if you only have a few nests they may be placed under a tree facing the north and covered with waterproof material. If the nests are placed in the houses the hens will sleep there instead of on the roosts, and will leave their droppings behind them.

Now I shall say something which will probably surprise most of my readers. There is no necessity to lime-wash the fowl-house for fear of vermin. If you saw my yard you would be surprised at the absence of the whitewash brush; but if you looked carefully you would notice also the absence of lice. Paint the joints and the end of the roosts once a month in cool weather and weekly in hot weather with kerosene or wood-preserving oil to which you have added a little strong-smelling disinfectant, and you need have no fear.

The farmer may not have time to clean his fowl-house out every day; in that case let him just dust the droppings with wood or coal ashes and he will neither have a disagreeable smell nor any vermin. The fowls, too, will eat the charcoal mixed with the ashes. Remember this, that fowls do not breed vermin, but that dirt does.

Dust the nest once a month with tobacco dust, and let the birds have some clean soil for their toilet, and you will have no trouble with lice.

You will ask me which are the best breeds to keep. There is no best breed, but there certainly is a best strain of each breed, and it lies with you whether you will spoil or improve the strain you fix upon.

Naturally there are certain breeds more suitable for the table, and certain other breeds that are specially adapted for egg-laying. If you want an all-round bird, good for eggs and good for the table, choose the Black Orpington or the Langshan. Either of these will lay up to 200 eggs per hen per year. A few years ago if I had told anyone this they would have laughed, but good breeding and good feeding have brought poultry along to the 200-egg stage, and it lies with us to get 300 eggs per hen.

I advise that you keep the pure breeds of fowls, as by crossing two of the best laying breeds you produce mongrels.

If you are looking for a layer only, a single-comb White Leghorn will take some beating. But for laying when eggs are dearest give me a good strain of Black Orpington or Langshan. Most people who fail with the Asiatic breeds do so because they allow them to get too broody instead of taking them off the nest before they lay their last egg. If the birds are put into a strange-looking coop, and fed well for two or three days, and are then put back into their own pen, they will start laying again as briskly as ever.

In mating your fowls be sure to have plenty of hens with the male bird, say twelve hens with a first-season cock, and seven or eight hens with a second-season bird. It is a great mistake to have too few hens to each male bird, as this entirely defeats the object aimed at—a large proportion of fertile eggs.

The most important knowledge one can have in the poultry business is how to feed. Feeding stud birds is vastly different from feeding the laying stock for the production of market eggs.

Take the stud birds first. They get two feeds, one in the morning and one at night, both of grain. Do not give them their full, but allow them a good range with plenty of green stuff.

The laying hens should be well fed three times a day, with mash morning and noon, and grain at night. It is not essential for egg-laying that they have green stuff, but they should have for the benefit of their health. They must have grit of some sort to grind up their food, and oyster or sea shell to provide the lime in the egg shells. As an egg is largely composed of water, the hen should never be allowed for a single hour to be without plenty of fresh water.

In setting out to get market eggs, the feeding is much more important than most people think. Some poultry-keepers go crazy on green feed, but, whilst this is good, as I said before, for the health, it has no particular egg-making value. For eggs you must feed solid food, and good quality at that. A crop farmer would not expect to get a big yield from played-out soil unless he fed it well with manure. So with the fowl: If you want the eggs, you must supply the kind of food that will make eggs. And as the hen requires a certain quantity to maintain her own strength, you must bear in mind that it is only the surplus which goes into egg production. The dairyman will understand this. If a hen is not in good condition she cannot lay well.

I believe I was the first to advocate feeding the laying hens as much as they cared to eat three times daily. People have told me that if they fed on this principle their hens would die of over-fatness. To that I reply that if a bird will not stand heavy feeding she should have her head cut off, as she is clearly by nature and constitution a table bird and not primarily an egg layer. A good layer can be compared to a good milking cow. Just as with the good cow the surplus food goes into the production of milk, so with a good laying hen the surplus goes into the eggs instead of into fat.

Some advise that the hens ought not to be fed until they have enough, and that the quantity should be measured out. This is all rubbish. Big results can only be obtained from high feeding.

The oftener you clean out the hen-house the better. You cannot afford to feed high-priced grain to keep up vermin.

Turkeys are very nervous birds, but will repay care and attention. Try to bear in mind that the turkey is practically half a wild bird, and give them just that mixture of care and neglect that meets the case.

During the hot weather farmers will do well to see that shelter is provided for their chickens and young poultry stock. If left out in the sun, they must inevitably get a set back from which they will never really recover.

OLD HENS.

A common complaint amongst those who keep fowls as an adjunct to the farm is, that the birds do not lay a fair number of eggs. It is remarkable how such persons stand in their own light as regards the management of their poultry. They will persist in keeping their old hens year after year, instead of keeping early hatched pullets. We have repeatedly noticed that farmers who are offered a good price for pullets promptly sell them all off and retain the old hens. This simply means that the nearly worn-out old birds either stop laying for two or three months, or, if they do lay, only produce from two to three eggs, and then start to sit. Now, supposing that they were to sell off these practically useless hens at even 1s. each, they would be really saving money. For, supposing a man has forty old hens, costing, say, 2s. each for corn, he is actually paying at the rate of 2s. a head for them, and getting no return for his outlay. Now, suppose, further, that these forty old birds are disposed of, and forty pullets kept. If they are anything like worth keeping, they will pay for their keep twice over, and, in the same year, will be worth double as much as the old useless hens.

Why should the poultry-keeper act differently to the dairy farmer? We do not find them sticking pertinaciously to old cows. If the cow neither gives sufficient milk to pay for its keep, nor puts on flesh, what does the dairyman do? He just puts her in the market and sells her for what she will fetch, and in so doing he is a gainer. Let the poultry-keeper do the same, and he will not have to complain that poultry do not pay

IN-BREEDING.

In-breeding is recommended by many writers, and especially for show purposes. The theory has been advanced that the wild birds in-breed, and yet they are healthy. In many instances this is right, but it must be remembered these birds only lay in the spring and summer, according to their nature.

Poultry people keep their birds to lay eggs during the autumn and winter months, which is quite a different matter. If we domesticate our fowls for our convenience, then we must breed and treat them accordingly. If we are going to breed for show, then it is wise to do a little in-breeding, but not to the extent it is recommended; if so, their constitutions are undermined.

We have experimented with in-breeding in every variety, and some stand it much better than others. Take, for instance, a man who in-breeds his poultry for show purposes. Say, he breeds seventy fowls; he picks out just the strongest of the young ones, not more than fifteen or twenty, to breed from in his own yard, and more often not half that number.

It is a frequent thing to hear breeders say of pure birds, talking of others' stock, and we hear the remark especially at shows, "Yes, that exhibitor has some real good birds; but he in-breeds too much." The answer to that is usually, "How do you know that?" The reply is, "We once bought a stock bird or birds from him, and they soon died, as they had no stamina."

There are hundreds who do the same. We once knew a poultry-keeper who bought all his stock birds from people who win at most of our shows—that is, the small birds, which are usually called the "culls." These were all bought cheap, and what was the result. Out of very nearly 500 pullets, upwards of 100 wasted away, and the others did not average sixty eggs each during the year. The poultry-keeper came to grief, and the money was lost.

If eggs or good table birds are required—that is, good strong table birds—the stock must not be in-bred; if so, the birds do not fulfil their mission. Those who write articles on in-breeding do a great deal more harm

to the utility poultry-breeders, as they write that they can in-breed and yet do well. In one way it pleases them, because they need not yet buy fresh male birds, but it is misleading to those who do not know any better.

We will take our readers back to the farmers of twenty years ago, when the whole village would not have fresh blood for years. The system was for farmers' wives to exchange male birds about every two or three years with each other.

What was the result? In many cases they did not breed a chicken until the end of spring, and not many of them before the middle of summer. The simple reason was they could not get a hen to sit before that time.

We can well remember the time when farmers did not have a single egg for three or four months during the autumn and winter. (1) Because they in-bred. (2) They bred from mongrel cocks. (3) They made no selection of their stock, partly because they fed them on the very poorest of grain, such that the millers would not grind for their pigs.

Fortunately, these last few years farmers have treated their fowls differently. What brought them to do so? Bad times, and the purchase of fresh blood; they gave the birds better food, and what has been the outcome of it all? They have made better prices for their poultry and eggs, and find there is nothing pays better on the farm than poultry.

General in-breeding with ordinary stock kept for utilitarian purposes is a step backwards, and it means loss and disappointment.

It must be remembered there are poultry-fanciers who keep birds for show who do not get eggs in winter, and in many cases they keep a number of mixed birds of all kinds to lay eggs for their own consumption. But when people keep prize birds of the up-to-date utility breeds, they lay eggs all the autumn and winter.

This is one reason why the Orpington varieties have spread so marvelously fast as show birds.

We always recommend our readers to take up the newer breeds because of fresh blood having been used, and the introduction of this always means added inactivity to the egg organs.

When they complain that new varieties are not good layers, it is the fault of those who have handled them.

There is no specific way to make hens lay. Many things will tend to increase the number of eggs laid. Volumes have been written upon the subject, and each writer lays special stress upon his or her remedy. We cannot go into detail, but will give a list of the help recommended, and our readers can try the ones they think most applicable to their own case:—

1. Certain birds lay more eggs than others.
2. Young hens lay better than older ones.
3. Certain individual hens have the laying capacity more highly developed than others.
4. Green food tends to make them lay.
5. So does green bone cut up and mixed with their food.
6. So does cooked meat.
7. So does a variety of mixed food.
8. Red pepper mixed in the food.
9. Clean water every day.
10. Clean quarters or hen-houses.
11. Food given in straw or leaves to make them scratch for it.
12. Everything that you can do to have them in prime condition and perfect health.—“Farmer and Grazier.”

The Orchard.

GRAPES FOR EXPORT.

A very interesting and important experiment has been lately carried out, through the courtesy of the Agent-General for Victoria in London, Mr. Taverner, at the instance of Mr. H. H. Davey, editor of the "Fruit World of Australasia." Recognising the as yet undeveloped prospects in the matter of grape export, that gentleman decided to obtain a sample of the Spanish export grape from Spain for the benefit of growers, and accordingly wrote to Mr. Taverner in August, 1908, asking if it would be possible to obtain through the latter's good offices one of the usual export barrels of Almeria grapes. Mr. Taverner promptly responded by at once consigning a keg of these grapes to Mr. Davey, care of the Victorian Minister for Agriculture.

The "opening ceremony" was performed on the 8th December at the Government cool stores, in the presence of Mr. Duffus, secretary for agriculture, the viticultural expert, Mr. F. de Castella, Mr. J. G. Turner, chief inspector of fruit, and Mr. H. H. Davey, editor of the "Fruit World of Australasia," representatives of the daily and weekly Press, a good number of city fruit merchants, and others interested.

The barrel was made of oak staves, the timber used by the Spaniards for shipping first-quality grapes, and the gross weight was 60 lb. The empty cask, which measured 15 in. diameter by 16½ in. deep, weighed 12 lb., the cork dust 8¾ lb., and the grapes over 40 lb. This was slightly under the weight expected, but allowance has to be made for evaporation. The grapes, which were of the variety Ohanez, were opened up in splendid condition, only one bunch showing any signs of decay. Their carrying power may be better estimated when it is known that the keg was carried as ordinary cargo from Spain to London, and then from London to Melbourne, there being no need for refrigerated chambers.

In speaking of grapes, the word "Almeria" must not be misunderstood. Almeria is a coastal district in southern Spain, and many varieties are grown there, but of them all the best carrying grape is the one now under review—viz., the Ohanez.

People on the other side might as well speak of "Tasmanian" apples, which would convey nothing but a general meaning, because Tasmanian apples are made up of many varieties; but if we speak of "Jonathan" or "Sturmer" apples from Tasmania, the meaning is at once clear. Equally so, the term "Almeria grapes" is a general one, while the variety which has these unique carrying qualities is the "Ohanez," or, to be more correct, the "Casta de Ohanez." In appearance it is not unlike both the "Waltham Cross" and the "Lady's Finger," though somewhat smaller than the latter.

Everyone present was delighted with the experiment, which is in reality an object lesson to Australian growers, and is sure to pave the way to further developments; at least, we hope so. Why should not the grower of wine grapes, make an adjunct of grapes for export? Why not the grower of, say, Gordos, have his hand on three things in case of failure in one or two—viz., dried fruits, export fruits, and wine production?

The fruit, as illustrated, is very handsome, the flesh is firm and sweet, and when sampled the taste was as fresh and pleasing as if picked the same day; in fact, the bloom was still on the fruit, though picked twelve weeks. Besides its high quality and carrying powers, it also has the distinct advantage of being mould-resistant. According to Mr. de Castella, this variety ought to thrive in Victoria and South Australia, where the air is drier than that of Almeria. The climate of Mildura is specially suitable, because the

resistant qualities of the Ohanez would be equally well developed. The advantage to Australian growers would be the obvious one of being able to place the fruit on the markets of the other side of the world when Spanish grapes would not be available. Prices range from 8s. to 13s. per barrel of 53 lb. net in London.

No less than 2,500,000 barrels were despatched from Almeria to London, America, Germany, and other parts of the world last season.

No treatment of any description is applied to the grapes before shipment. They are simply picked and packed. The fruit, however, is usually gathered rather on the unripe side. It completes its maturity while in the keg amongst the "serim" or granulated cork in which it is packed. In Almeria the grapes ripen about October, but the packing and shipping go on until the end of December, and even much later, as this grape hangs well.

This period would mean from April to July and August in Australia.

The packing in barrels is not essential. It certainly is an advantage to have a package with no corners, and the barrel or keg is very convenient in many ways. The Spanish growers are conservative, but in this instance their conservatism is not misplaced, as they get excellent returns. Still, if in Australia we did not copy the Spaniard in this respect, we could doubtless provide a very good substitute. The barrels are made of oak, chestnut, and pine, according to the quality of the fruit, the best being put up in oak. The standard size of the barrels is 22 in. stave by 12 in. at the bung. The price of the oak barrel is about 2s.; the pine barrel is cheaper. The granulated cork is very cheap, being milled from the waste. There would be no difficulty in Australia in obtaining this commodity.

A recent report from London reads as follows:—31st October, 1908: Grapes.—Almeria are fine, but there is an absence of fine fruit, all parcels showing waste; ordinary are 7s. to 9s.; selected, 9s. 6d. to 12s.; fine, 13s. to 15s.; finest, 16s. to 20s. This is from 2d. to over 4½d. per lb. wholesale.

On being interviewed in reference to the shipment of Almeria grapes, Mr. J. M. Jacobs, of the firm of Geo. Lister, Western Markets, Melbourne (and of the family of Garcia, Jacobs, and Co., and Edward Jacobs and Co., Covent Garden, London), said—"As far as Almeria grapes are concerned as a market commodity here, I am inclined to think you won't do much good unless it be in the way of a novelty, for this reason: That they would come on to our Australian market when strawberries, cherries, and other summer fruits are plentiful.

"It is very well in England, where the need of winter fruit in the way of grapes is felt, for they come upon their market when there are no summer fruits available; but in Australia it is different.

"I have always advocated for years the bringing in of the Almeria grape vine, for the purpose of marketing the fruit across the sea.

"It would not necessarily mean adopting the barrel for packing if we can find among our hardwoods something that will hold tightly together and keep out any moisture or cold air. And we could then use in our own cases the granulated cork which we saw when unpacking the barrel of Almeria grapes.

"The question of importing the vine which grows this variety should receive immediate assistance from the Agricultural Council, but care should be taken in the selection of the vineyard, as soil and climate influences will have to be reckoned with. There is no doubt that the Almeria grape will carry to Australia—that has been clearly demonstrated to us in this instance—but so have oranges and lemons carried to Australia from Italy, and yet

we cannot land an orange or a lemon to a certainty on the other side. It is clear, to my mind, that we must have hardy varieties of fruit if we intend exporting afar.

"Varieties in Australia are well suited to their own markets, but totally unsuited for export.

"South Australia exported grapes, putting them in the Covent Garden market in a more or less good condition, while others had arrived 'dead rotten,' and this disheartened the exporters to a very large extent. But I look to this Almeria grape (if it can be cultivated in Australia with the same tough, hardy qualities as in Spain) for a big development in the export grape trade from Australia, and even as apples carry with great certainty now, producing a big trade, we may look forward at no far distant date to seeing the Almeria grape from Australia on the Continental and English markets.

"In London the grape has been known to keep in the cellars under the market stores at Covent Garden for a period of anything between a month and six months. I am not going to say that after a lapse of six months the grapes will not require to be picked over to cull out the bad, but grapes have kept for six months under these conditions, and although the atmosphere there at this time of the year is different from that in Australia, we can bring cool stores to our assistance.

"The grape export from Spain to England has been going on for the last fifty years. A small syndicate of Covent Garden men, under the direction of Ben Symons, were the first promoters, and subsequently Michael Symons, formerly a Glasgow baillie, organised a regular carrying fleet for the promotion of this industry, carrying between the grower in Spain and the consumer in England. There were times when enormous profits were made. Since then the trade has gradually settled down, and although some of the grapes are sold at Covent Garden, the majority find their way to Pudding lane and Monument yard, where the dried fruit auctioneers hold sway. The estimated value of this fruit in England is somewhere between 6s. and 15s., according to condition and sample. The barrel is always used, because it is the most air-tight article that the trade can use for the purpose. I hope the Council of Agriculture, having put their hand to the plough, will go further, and import the vines of this variety, which will enable Victoria and other parts of Australia to compete successfully with grapes in the world's markets, as has been done with other fruits."

Amongst those present at the "opening ceremony" of the keg of Almeria grapes was Mr. F. Thomas, of the firm of Thompson, Thomas, and Co., King street, Melbourne. This firm has had considerable experience in the shipping of grapes, the bulk of it, however, being done through their London house. Their experience has confirmed them in their opinion that this "Ohanez" (Almeria) grape is the only safe variety for shipment. Large quantities are sent to Ceylon and the East between the months of September and December. The method of shipping is the same as has already been described—viz., the packing in cork-dust in kegs. The grapes are shipped as ordinary cargo.

Of course it is not impossible for even this excellent variety to miscarry, but the error would be through faulty picking, over-ripeness, or bad stowing aboard ship. The Australian grapes have not got that thick, tough skin necessary, but of our many varieties Mr. Thomas thinks the Doradilla the best. If the "Ohanez" (Almeria) grape were cultivated here, it would have a grand future as regards export, as the grapes from here would be placed on the English and Continental markets when there would not be a Spanish grape available, our grape season being in full swing in March.

Mr. de Castilla, it is reported, brought cuttings from Europe of the variety under notice, and these are now being propagated at Rutherglen (Vic.).

CORK WASTE.

Cork waste for the packing of grapes for export appears to be available in large quantities in Melbourne, Messrs. Vogt Bros. having stated that they hope to be able to supply many tons of granulated cork, the waste from their factory, should there be a demand for the article amongst fruit-growers.

In this connection, some account of the cork industry in Southern Europe will prove of interest, especially as portions of all the States of the Commonwealth of Australia would seem to be well adapted climatically for the growth of the valuable cork oak (*Quercus suber*).

Mr. François de Castilla, of Melbourne, who recently visited Southern Europe on a viticultural mission, writes as follows on this subject:—

“It was in Portugal that my work brought me most in contact with this remarkable tree, which is in several districts of that country cultivated in close proximity to vineyards. In Spain the chief cork-producing regions were not sufficiently remarkable from a viticultural point of view to cause me to visit them. Most of the information I have collected is, therefore, derived from Portuguese source.

“The Peninsula is no doubt the home of the cork oak. I understand there is quite as large an area in Spain as in Portugal, and that results are equally remunerative. In Algeria large cork forests also exist, and, though I am not in possession of statistics as to extent, I understand that they are very profitable and yield an excellent return on the money invested in them.

“Even in the South of France, cork forests are to be found, but the climate (colder than that of Australia) is not so suitable as that of the Peninsula.

“Portugal possesses, in 1900, 525,000 acres devoted to the cultivation of this tree. In that year the cork produced amounted to 50,000 tons, of a value of 3,671,736,000 reis (equivalent, at par, to £814,290 of our money). In other words, the cork forests of Portugal yield on an average over 30s. per acre per annum. The best established and best cared for plantations yield, of course, a far higher annual return.

“The above figures are exclusive of the value of the acorns produced, which in itself amounts to a considerable sum. The acorns constitute excellent pig feed, though in this respect the cork oak (*Quercus suber*) is less productive than the *Quercus ilex*, another form of evergreen oak. It nevertheless produces large quantities. About half a century ago the *Ilex* was, on this account, more popular; but, owing to the increasing demand for cork, it is now being largely replaced by *Quercus suber*.

“Statistics show the importance of the acorn crop of these two oaks in Portugal. Out of 1,000,000 pigs raised each year in the country, it is estimated that 300,000 annually are fattened on acorns. Many land-owners fatten their own pigs, but in many cases they graze them, some pig-owners paying as much as 30s. per head for the season.

“Even the timber of this remarkable tree is of value, but, it being very long-lived and regularly productive, it is seldom used for this purpose.

“Our Victorian climate should prove exceptionally suitable for it. The Portuguese consider the part of their country south of Lisbon to be its true habitat. The way in which our Australian trees—gums, blackwoods, and she-oaks—flourish near Lisbon, where they are largely planted, leaves no doubt as to the suitability of the greater portion of Victoria for cork culture.

“The chief cork-producing districts of Portugal are those of Beja, Evora, Portalegre, and Algarve. One also sees large plantations in the valley of the Tagus, on the railway trip from Oporto to Lisbon. The trees receive no cultivation, though the ground is kept clear of scrub and rubbish. Suckers are usually removed to let in air, and also to promote the formation of acorns for pig feed. Of all forest trees grown in Portugal, it is the one which is best looked after, and which yields the most handsome returns.

“The first crop of cork is usually obtained at the age of fifteen years or so, though the bark for tanning purposes is often removed at the age of four years. When in regular production, the trees are stripped every nine or ten years, it being customary to strip one-tenth of the plantation each season, a regular and uniform annual production being thus ensured. Stripping is usually performed between the 1st June and 30th August (1st December and 30th February in Australia), the operation being performed in much the same way as we remove a sheet of bark from a stringybark tree. The appearance of the trunks, after removal, is very striking—at first of a vivid orange-red colour, they become gradually darker until quite black. Though the bark is entirely removed from the trunk, as deep as the cambium layer, no injury seems to be done to the tree, which immediately sets to work to grow a new bark.

“Rich soil is not essential for the culture of cork. On poor soil, though the growth is slower, the quality is usually superior. I have seen large plantations in poor sandy soil, of little value for agriculture. I feel sure we possess large areas of poor land in Victoria excellently adapted for the cultivation of this valuable but neglected tree.”

NEW BORDEAUX MIXTURE.

At the Woburn (England) Experiment Fruit Farm investigations have shown that the clear lime-water made by slaking 3 lb. of quicklime in about 100 gallons of water, and then adding 86 gallons of this clear solution to 14 gallons of water in which 6 lb. 6½ oz. of copper sulphate have been dissolved, will yield 100 gallons of Bordeaux mixture superior to and cheaper than that made according to the commonly accepted formula. As our ordinary commercial forms of quicklime vary exceedingly in its essential constituent—viz., calcium oxide—the potassium-ferro-cyanide test becomes essential if anyone is disposed to give this formula a trial.

FRUIT CASES.

A report from South Africa states that £3 15s. is being paid for *Pinus insignis* trees, about eighteen years old. Presuming they had 200 of these trees on 1 acre, they would obtain a return of £30 a year for eighteen years. A Mr. Newmarch stated that he was making boxes with wattle wood. It had been brought to his notice that the ends of the boxes would have to be made with a soft wood. He decided to try *Pinus insignis*, and, as some of these trees are growing on a neighbour's property, he obtained permission to cut one down. He found the wood very suitable for what he wanted, and had paid 9d. a cubic foot for the wood, which totalled £3 15s. for the tree. Many people did not consider it worth while to grow this tree, as it generally died when seventeen years old. He had found the wood as soft as deal, and as good as the best deal. He considered that 200 of these trees could be grown to the acre, and he thought that there were few crops that would give such a return. A Colonel Crompton stated that he had had experience with these trees, and, though he did not wish to depreciate the *Pinus insignis*, he thought the *Pinus pinaster* would do better. It grew splendidly, though more slowly.—“Fruit World.”

BEATING THE FRUIT FLY.

Mr. W. J. Allen, Government Fruit Expert, New South Wales, says that the inspectors under the Fruit Pests Act are not averaging one specimen of the fruit fly a week, whereas last year thousands could have been found daily. There has been no fly in apricots or peaches so far, though an occasional one

may be expected from now on. "The way the people are working," says Mr. Allen, "has helped to keep the pest under. If they keep on fighting it, I am satisfied that we won't have much fly, except on the Northern Rivers, where not a great deal of fruit is grown. The majority of growers are doing their best to carry out the work of destruction." Mr. Allen is of opinion that there is something in the season that has proved even a more important factor than the preventive and suppressive measures taken under the Act.

A NEW MANGO.

Amongst the new fruits which are under experimental culture by the United States Department of Agriculture is a mango of Indian origin, known as the "Sandersha" variety (says the "Agricultural News" of Barbados), first introduced into Florida in the year 1901, and of which the following particulars are given in an article in the departmental Year Book (1907), with coloured illustrations:—

Of the mangoes that have so far fruited sufficiently in Florida to disclose their distinctive characteristics, the Sandersha is one of the most unique, and in certain respects the most promising. It was introduced by the Section of Seed and Plant Introduction in 1901, having been received from Bangalore, India, in the form of two inarched trees. A second lot of inarched trees received from Mr. W. Gollan, Superintendent of the Government Botanic Station at Saharanpur, India, under the name "Sundershah," has not yet fruited, but is believed to be the same sort. Little appears to have been published in India regarding the variety, but at the Subtropical Laboratory of the Department at Miami, Florida, where it has been fruited for two seasons, it has proved very productive, of exceptionally large size, fine dessert quality, and very late ripening season, all of which points are apparently in its favour as a commercial sort. Mr. P. J. Wester, of the Subtropical Laboratory, considers cross-pollination necessary to insure productiveness.

The Sandersha mango is long in form, compressed, and rather slender, tapering toward stem, and terminating in a distinct curved beak at the apex; size, very large, averaging about 20 oz. weight, and occasionally attaining a weight of 2 lb.; stem stout, apex prominent, curved and "beaked"; surface smooth; colour clear yellow, with a faint pinkish blush in the sun; dots numerous, small, russeted; skin moderately thick; seed long, curved, thin, small in proportion to size of fruit and thickness of flesh; flesh rich reddish-yellow, juicy and tender, almost entirely free from fibre; flavour refreshing in the fresh state, though with rather less aroma than the Mulgoba. Its higher acidity will doubtless render it more acceptable for serving in sliced form than are most of the mangoes thus far obtainable in the United States' markets. This mango is a late variety, ripening in the latter part of August at Miami, Fla. The "Sandersha" is considered well worthy of testing in the mango districts of Florida, Porto Rico, and Hawaii.

THE MARKET FOR FIBRES.

From the "Journal d'Agriculture Tropicale" we take the following prices for sisal and other fibres. It is satisfactory to learn from that journal that since the slump in June last, when the price of sisal fibre dropped to £25 per ton, prices have gradually risen, and also that there is an increasing demand, which must result in much higher prices during the next few months. Sisal is quoted at £29 17s. 4d., ixtle at £23 12s. 10d., Mauritius at £22 16s. 6d., ramie at £31 18s. 9d., and Manila at £36 1s. 9d. per ton. It should be noted, however, that these are top prices for the best samples.

Apiculture.

AUSTRALIAN HONEY IN ENGLAND.

From the "Journal of Agriculture" of Western Australia we learn that little, if any, profit is to be derived from exporting honey to England. During the year 1908, the Beekeepers' Association secured the assistance of the Department of Agriculture to send to London a shipment of West Australian honey, in order to test the market. This step was prompted by the unsatisfactory position of the honey industry in that State.

It is said that, except during seasons when natural blossoms are peculiarly scarce, the State demand for honey is fully met, and, for want of some sort of organisation, sellers so cut down prices that wholesale merchants are not able to offer to producers a price which will induce an increase of production. On the other hand, indiscriminate exportation in the past has given to Australian honey in England a bad name, which has been used by large dealers connected with the honey trade to work their own ends.

For the purpose of promoting a more favourable appreciation of West Australian honey, a consignment, specially collected by the Beekeepers' Association, was sent to the Agent-General in England. A request was, at the same time, made to have that honey put up in attractive form, and placed on the market. It was thought that the West Australian Court would materially help in this work of distributing the honey in conjunction with others specially conversant with the trade.

The result, as reported by the Agent-General, has been anything but satisfactory, and, instead of the anticipated prices of 4d. to 5d. per lb., the consignment was sold at 15s. per cwt.

The average price of honey imported into the United Kingdom last year was about 25s. 6d. per cwt., French honey selling at 50s. per cwt., West Indian 22s., and the United States between the two, with an average of 26s. 6d.

Altogether the imports into the United Kingdom from all sources only amounted to the small total of 26,354 cwt., valued at £33,397.

BEE NOTES.

The hon. secretary of the Queensland Beekeepers' Association (Mr. G. Butler) forwards the following bee notes:—

Mr. F. C. Golder, of the Grange Apiary, Pittsworth, writes as follows:—

"Honey is now coming in freely from lucerne, which is blooming profusely and producing a lovely flavoured honey. Prickly pear comes out in bloom early in November, and continues for about a month. I consider it one of the best honey-producing plants we have for building up the colonies, as it produces both pollen and honey in large quantities—in fact, I find no other honey plant to come anywhere near it for stimulating the bees. The honey is nearly as white as that produced from lucerne, but it has a distinct flavour of its own, also it is of a cloudy appearance. The one objection I have to it from a commercial standpoint is that it granulates very quickly; in fact, even in mid-summer it will become solid within a week of being extracted. There is no doubt it would be a honey of first merit for selling in brick form, as it will remain solid at a temperature of 100 degrees Fahr.; but, as I mentioned before, we only get a very limited quantity, as the bees use the bulk of it for brood-rearing. Should you require a sample in its purity, I will be pleased to forward same for analysis, to refute the statement that has been published—namely, that prickly-pear honey is of a rank flavour, and not fit for human consumption."

Mr. Golder is one of Queensland's up-to-date beekeepers. In order to cope with his increasing apiaries, he has been compelled to instal an 8-frame reversible honey-extractor, and a 1-h.p. gasoline engine to run it. It has been imported from the A. I. Root Company, through their local agent, Mr. H. Jones, of Goodna. It is capable of extracting 1 ton of honey per day.

Sericulture.

ERI SILK.

In our description of the various kinds of silkworms in the November number of the Journal (1908) will be found a reference to the Eri multivoltine silkworm. We are now enabled to place before our readers further information concerning this valuable silkworm, contained in a pamphlet on Eri silk, by Anukul Chandra Roy, in the Bengali language, a translation of which was supplied by the assistant to the officiating Director of Agriculture, Bengal, to the Ceylon "Tropical Agriculturist," and appeared in the December (1908) issue of that journal. Following is the translation:—

The writer principally gives suggestions regarding the method of rearing Eri worms. He begins with stating the profitableness of the Eri silk culture. He says formerly Eri cocoons used to be sold at Rs. 50—60 per maund; but now they are sold at Rs. 100—150 per maund; also pure white cocoons fetch higher prices. The rearing work can be done by the female members of the family, without any interference with the household duties. The worms feed only on the leaves of the castor plant, and the seeds can be readily sold in the market.

Castor plants should be grown about a year before the rearing work is taken in hand. When the castor is ready, a bamboo machan with three or four shelves is to be prepared in a room or veranda, when it is proposed to carry on the work on a small scale; when a large number of worms is meant to be reared, a separate house has to be built. A few bamboo trays and baskets are to be secured. The trays, baskets, and shelves are to be washed with a 1 per cent. solution of copper sulphate. Ants, birds, frogs, and wasps are great enemies of the worms. In order to prevent these, a fence is necessary round the machan; also the following compound is to be painted round bases of the posts of the machan:—

Castor oil, 1 seer; resin, $\frac{1}{2}$ -seer. Boil, and then add 30-40 drops of the milky juice of Calotropis.

After these are ready, eggs can be got from Assam; or some seed cocoons can be got and eggs secured from the moths which will emerge. The eggs are to be dipped in the copper sulphate solution, dried in the shade, and then kept spread for hatching. They will begin to hatch in eight or ten days in winter, and earlier in summer.

The young worms soon crawl up to the tender leaves of castor, which are to be placed on them at noon, and can be easily transferred to a separate tray. The worms of the first day are to be paced on the lowest or highest shelf, and those of the next three days (collected every day at noon) on the next higher or lower shelves in order. The eggs can be thrown away after the fourth day, as by that time all will have hatched. Until the worms are about 1 in. long, young leaves are to be cut into small pieces and supplied as food. In order to bring up the worms of the different dates to an equal growth, the worms of the first day are to be fed three times a day, those of the second day four times, and those of the third and fourth days five times a day. After four or five days all the worms will be found to be of an equal size, and they can then be mixed together. They are to be fed five times during the day and night—at 6 a.m., 10 a.m., 2 p.m., 6 p.m., and 10 p.m.—until they are ready to spin cocoons. Every day the trays are to be cleaned. The worms moult four times, and should not be given food while they are moulting; also they should

Plate XVII.

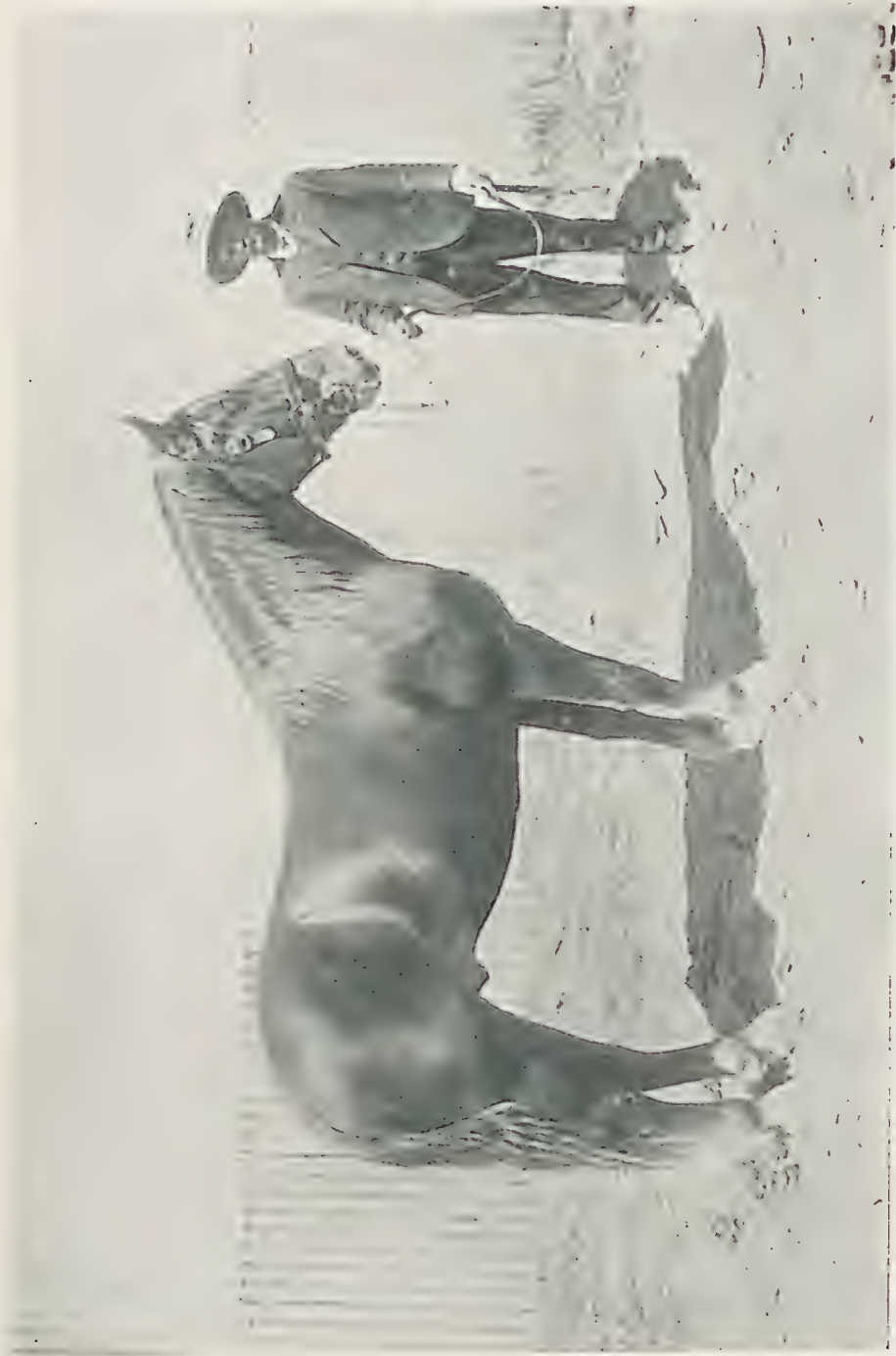

IMPORTED SUFFOLK STALLION, GLENTHORNE MONARCH.

not be fed with wet or dusty leaves. They spin cocoons in about fifteen to twenty days in summer, and in about twenty-five to thirty days in winter. They can be made to prepare cocoons either (1) in the small chambers of a chandraki specially made, or (2) in the angles formed by two or three sticks tied in the middle in a branching manner, or (3) in a mass of dry plantain leaves or papers. After three days the cocoons are to be picked out and kept in a basket. The moths are to be allowed to escape from the cocoons.

For seed, those cocoons should be selected which are (1) white, (2) big, and (3) formed by the most active and restless worms.

The cocoons are boiled in ashes and water or in a solution of washing soda. They are then washed with cold water and dried; and then carded and spun into thread like cotton lint.

Statistics.

COMMONWEALTH METEOROLOGY.

RAINFALL OF QUEENSLAND.

TABLE SHOWING THE TOTAL RAINFALL FOR EACH MONTH OF THE YEAR IN THE AGRICULTURAL DISTRICTS OF QUEENSLAND.

| STATIONS. | 1908. | | | | | | | | | | | | |
|-------------------------------|-------|-------|-------|-------|--------|-------|-------|-------|------|-------|------|------|------|
| | Dec. | Jan. | Feb. | Mar. | April. | May. | June. | July. | Aug. | Sept. | Oct. | Nov. | Dec. |
| <i>North.</i> | | | | | | | | | | | | | |
| Bowen | 6.39 | 10.14 | 5.63 | 9.46 | 3.73 | 0.99 | 0.45 | 0.88 | 0.51 | 0.96 | 2.47 | 0.42 | 0.42 |
| Cairns | 28.33 | 27.02 | 8.03 | 20.60 | 5.99 | 3.05 | 0.59 | 3.70 | 2.12 | 0.74 | 3.07 | 1.60 | 1.41 |
| Geraldton | 33.82 | 14.39 | 13.27 | 39.00 | 14.23 | 18.52 | 2.64 | 8.11 | 3.66 | 2.81 | 6.93 | 3.80 | 1.69 |
| Glndie State Farm | 4.42 | 0.20 | 7.17 | 6.25 | 0.02 | 0.112 | ... | 0.40 | 1.27 | ... | ... | ... | ... |
| Herberton | 9.57 | 9.29 | 5.02 | 8.92 | 1.40 | 0.38 | 0.31 | 2.36 | Nil | 0.51 | 1.27 | 0.61 | 0.78 |
| Hughenden | 7.75 | 0.98 | 5.18 | 6.91 | 0.30 | Nil | 0.05 | 0.68 | Nil | Nil | 1.67 | 1.94 | 1.03 |
| Kamerunga State Nurs. | 29.82 | ... | 7.47 | 25.75 | 1.60 | 3.363 | 0.76 | 4.85 | 1.53 | ... | 3.64 | 1.69 | ... |
| Mackay | 9.70 | 9.23 | 3.83 | 17.43 | 14.82 | 3.25 | 1.29 | 1.65 | 0.71 | 2.27 | 1.80 | 2.57 | 0.2 |
| Rockhampton | 4.42 | 3.84 | 9.64 | 9.77 | 2.62 | 0.85 | 0.10 | 1.08 | 0.84 | 0.20 | 2.14 | 2.47 | 1.37 |
| Townsville | 24.26 | 12.21 | 6.69 | 9.03 | 0.38 | 2.22 | Nil | 1.70 | 0.27 | 0.28 | 1.58 | 1.26 | 0.7 |
| <i>South.</i> | | | | | | | | | | | | | |
| Biggenden State Farm | 5.55 | 2.37 | 9.82 | 9.84 | 2.97 | 0.74 | 0.43 | 0.49 | 2.33 | 1.39 | 1.80 | 2.12 | 3.66 |
| Brisbane | 3.21 | 2.80 | 8.43 | 18.19 | 2.45 | 2.40 | 0.17 | 0.77 | 2.83 | 0.67 | 1.77 | 2.25 | 1.28 |
| Bundaberg | 2.99 | 4.77 | 2.82 | 7.35 | 4.13 | 0.67 | 0.39 | 0.75 | 1.56 | 1.10 | 2.39 | 0.73 | 3.34 |
| Dalby | 1.44 | 0.17 | 4.88 | 7.61 | 0.11 | 0.37 | 0.63 | 0.14 | 1.80 | 1.13 | 2.55 | 3.65 | 1.56 |
| Esk | 3.72 | 2.61 | 10.06 | 17.04 | 2.83 | 1.07 | 0.23 | 0.46 | 2.75 | 2.16 | 1.29 | 5.99 | 3.62 |
| Gatton Agric. College, | 4.55 | ... | 3.38 | 10.74 | ... | 0.10 | 0.16 | 0.6 | 2.71 | 1.84 | 1.93 | 5.71 | 1.29 |
| Gympie | 5.49 | 6.26 | 11.77 | 8.08 | 1.87 | 2.00 | 0.38 | 1.16 | 2.87 | 1.37 | 2.49 | 2.58 | 3.97 |
| Ipswich | 3.40 | 1.32 | 6.63 | 13.77 | 2.71 | 1.14 | 0.12 | 0.47 | 3.23 | 1.19 | 1.48 | 5.09 | 1.05 |
| Maryborough | 5.81 | 5.62 | 8.07 | 11.40 | 2.52 | 1.05 | 0.46 | 0.81 | 1.98 | 1.05 | 1.84 | 1.92 | 1.64 |
| Roma | 2.51 | 0.04 | 6.38 | 2.51 | 0.22 | Nil | 0.55 | 0.63 | 1.38 | 1.12 | 2.15 | 2.79 | 1.68 |
| Roma State Farm | ... | ... | ... | ... | ... | ... | ... | 1.27 | 0.73 | ... | ... | ... | ... |
| Tewantin | 7.36 | 10.42 | 12.47 | 14.39 | 7.59 | 8.66 | 0.75 | 1.97 | 2.70 | 2.18 | 2.30 | 7.50 | 4.12 |
| Warwick | 3.13 | 0.76 | 4.52 | 6.65 | 1.40 | 0.15 | 0.80 | 1.24 | 2.69 | 1.96 | 0.96 | 5.28 | 2.02 |
| Westbrook State Farm | 3.23 | 0.43 | 8.03 | 1.41 | 1.40 | 00.5 | ... | 0.49 | 1.97 | ... | ... | 2.05 | ... |
| Yandina | 3.05 | 8.37 | 14.47 | 16.62 | 5.45 | 4.59 | 0.58 | 2.64 | 2.18 | 1.50 | 3.10 | 6.03 | 2.75 |

NOTE.—The rainfall data in this table are compiled from telegraphic reports, and must be considered as approximate only.

GEORGE G. BOND,
Divisional Officer.

Horticulture

FLOWER GARDENING—No. 13.

PLANTS SUITABLE FOR IN AND OUT DOOR CULTURE.

By THE EDITOR.

MIMULUS.

This is often called "Monkey Flower." The Mimuli are extremely handsome, profuse-blooming plants, with singularly-shaped and brilliantly-coloured flowers, distinguished by their rich and beautiful markings. Sow the seed from March to May, in light soil, scarcely covered.

The Musk Mimulus and Harrison's Musk are well-known greenhouse plants. The roots of these, like those of mint, run under the surface of the soil, which, by continually watering, loses the nourishment so essential to the plant. Cuttings, well grown, make much better plants than those obtained by division of the roots. Plant a vigorous young cutting, well rooted, in about 4 in. of a rich compost at the bottom of a good-sized flower pot. It will grow rapidly. Then pinch out the leader, and as it grows, add more soil till the pot is filled to within 1 in. of the top. By this time, the pot is well filled with roots which have struck out from all parts of the plant thus buried; hence it grows more vigorously. Now place several sticks 2 in. apart all round the edge of the pot; draw and tie them together at the top, thus forming a cone 18 in. high. As the plant grows, put bands of fine matting round the sticks to keep the foliage inside. As the flowers appear, remove them until the trellis is nearly filled; then let it bloom at will. Now let the shoots come through the trellis and fall down round the pot, which will soon be almost invisible. The whole then represents a most beautiful pillar, 2 ft. high, covered with flowers of a larger size than commonly seen on Musk. Musk grown after this fashion never fails to carry off prizes at flower shows.

VARIETIES.

M. Clapham's Superb, remarkable for the great size and superb colouring of the flowers, and vigorous habit. M. Queen's Prize: Many of the flowers of this variety measure 2 to 3 in. in diameter, the colours comprising mottled shades of rich purple, crimson, and yellow, ruby, &c. *M. tigrinus albus*, white grounds handsomely tigred and spotted; *Grandiflora*, and *Moschatus* (Musk).

CANNAS.

Of all our tall-growing showy plants the Cannas are the easiest to cultivate. Under the name of "Indian Shot" they have been grown for many years in most flower gardens in Queensland; but of late years the old varieties have become quite obsolete, a new, and far more ornamental, species having taken their place. The Canna of to-day is one of the most beautiful of our decorative plants. They are quite hardy, nearly always in flower, and have fine foliage, like the leaves of the banana, only pointed. Cannas are not at all particular as to soil or situation. They form a very numerous genus, between the several species of which there is so great a similarity that it is needless to retain in the garden more than half a dozen of the best. They all have large lanceolate leaves, grow from 3 to 5 ft. high, and are apt to become exceedingly troublesome by throwing up suckers for a great distance around. They are easily propagated by division of roots or by seed. It is from the *Canna edulis* that Queensland arrowroot is made.

VARIETIES.

Africa, flowers resemble those of the *Cattleya* Orchid, a rich purple scarlet, golden yellow and orange inside; *Alemannia*, the giant flowering *Canna*, outer petals scarlet, with a rich golden border, inside of blooms scarlet; *Aphrodite*, grows to a height of 6 ft., flowers golden yellow, with large salmon-coloured spots; *Atalanta*, flowers orange-carmine; *Austria* (Orchid-flowered), flowers large, compact, of a beautiful canary-yellow colour. Other beautiful varieties are—*Asia*, *Bavaria*, *Burbank*, *Burgundia*, *Charles Naudin*, *Edouard André*, *Emperor*, and the *Dwarf Fairy*.

SUNFLOWERS (*Helianthus*).

This well-known annual thrives well in Queensland. Some of the tall-growing varieties attain a height of from 6 to 8 ft. with flowers of enormous size. The small-flowered varieties—*Stella* and *Cucumerifolius*—are most decorative and useful for cutting. It is one of the best yellow summer annuals. Seed should be sown in the Spring and Summer.

VARIETIES.

Russian Giant, Silver Queen, Double Miniature, *Stella*, *Orion*, *Nana compacta*, *Cactus-flowered* (resembling the cactus dahlia), *New Red Perennial*. This latter attains a height of 6 ft., and has beautiful red flowers. Its great beauty is not seen until the second year.

CLIMBING AND CREEPING PLANTS.

There is no cheaper, easier, and prettier way to decorate the exterior of a house than to have a variety of climbing vines around the porch and along the verandas. They not only provide a beautiful screen, with the green of the leaves painted by flowers of varying hue, but exclude the hot sun, and enable one to enjoy an easy chair in the open air when otherwise the sun's hot rays would render it impossible. The objection is sometimes heard that vegetation rots the woodwork which it shades, but this damage, if any, is not worth mentioning, and only calls for an occasional extra coat of paint.

ALLAMANDA.

This is a genus of handsome strong-growing shrubs; they are free-flowering, and, with one exception, their flowers are yellow. They form splendid objects trained over balloon-shaped or other trellises, where their rich golden flowers maintain a display for several months. The soil best adapted to their requirements is a mixture of equal parts of loam, leaf mould, peat, and sand; in fact, a soil such as is found in the virgin scrubs of Queensland. *Allamanda Hendersonii* has large, handsome, yellow flowers.

ASPARAGUS.

The shrubby species of *Asparagus* are graceful climbing plants, with finely-divided brilliant green leaves. The delicate branchlets are highly valued as being admirably adapted to the ornamentation of wreaths, crosses, &c.

Asparagus Sprengerii is a very elegant climber, well suited for hanging baskets. The foliage, as well as the fragrant, creamy-white flowers, furnishes a very beautiful material for decorating purposes.

The best soil for this plant is a sandy loam and vegetable mould.

ASPARAGUS OR LACE FERN.

This is the name often given to *Asparagus plumosus*. When the plants seem inclined to make one long vine rather than a bushy growth, nip out the centre when the shoots attain the height of 1 ft. or 18 in. Sprouts will then

appear from the roots or the nodes of the stem. If a plant fails to grow satisfactorily, shift it into a larger pot, and add porous fibrous loam for the new roots to penetrate. The great beauty of this exquisite foliage plant warrants all the care that can be bestowed upon it. It is really one of the most charming of foliage house plants, and should be one of the first chosen. It has no enemies; its culture is simple, and its propagation is readily effected by seeds, which come up with certainty after they have been in the ground for from three to four weeks.

ARISTOLOCHIA.

These singular but beautiful climbers may be seen in many of the gardens in the coastal districts of Queensland. They are remarkable for the size and peculiar form of the flowers, which in some species are of great size. *Aristolochia elegans* is a beautiful bush-house or green-house plant. The flowers are borne on long stalks, having a slightly distended tube, which is bent upwards. The upper portion is cup-shaped, and of a rich dark-purple colour, with creamy white markings, and having a golden-yellow eye surrounded by rich velvety purple.

A. grandiflora is an interesting plant, with handsome foliage and singularly-shaped flowers. Sometimes known as the "Dutchman's Pipe."

It is a fine creeper for a wall or fence, or side of a bush-house.

ANTIGONON.

This is one of the most beautiful and showy of slender creepers. It bears a profusion of lovely, bright, rose-coloured flowers and bracts. The plant thrives most luxuriantly in Queensland, and will cover an unsightly fence in a very short time. The seeds which fall will generally germinate, but the best way to propagate the Antigonon is to pot the thick root stocks in a fresh, open, well-drained compost, consisting of turfy loam leaf mould. At the end of Autumn cut the plant back close to the ground. In the Spring new shoots will be produced, which will grow rapidly and run to a distance of some 50 ft.

BIGNONIA.

Though most of this species are sufficiently hardy to thrive out of doors, such sorts as *Chamberlaynii* (*speciosa* and *venusta*) are well worthy of a place in the green-house or conservatory. They, however, grow too large for pot culture, and should, therefore, be planted in free soil and trained up posts and rafters.

All the Bignonias are worthy of a place in the flower garden, being easy of culture, fast growers, and beautiful as well as free bloomers.

After flowering, the old wood should be cut away, and young shoots brought up to take its place. Soil containing about one-third of peat is the most suitable. Cuttings strike freely.

VARIETIES.

Venusta: When grown on a trellis or trained against a wall the *B. venusta* is unsurpassed in the profusion or magnificence of its large racemes of bright orange-coloured flowers. *Mackeni*: This is also a grand evergreen climber, and in habit and growth resembles *Bignonia rosea*, but the flowers are more veined, and much deeper in colour.

Other good varieties are—*Capreolata*, climbing to 40 ft.; *Excelsa*, 20 ft.; *Fulvia* (yellow), 20 ft.; *Jasminoides*, 20 ft.; *Latrobeii* (cream); *Lindleyana*, 15 ft.; *Rosea* (rosy-lilac); *Tweediana* (yellow), 20 ft.

TECOMA.

Tecoma is a genus of evergreen and deciduous climbing plants, many of which are excellent subjects for the garden. The tecoma is found native in many parts of the globe, several species being indigenous to Australia. It is

closely allied to *Bignonia*, a genus containing some of the finest climbing plants in cultivation, and at present many kinds are described in nurserymen's catalogues as synonymous with *Bignonia*. The flowers of most of the species are produced during summer, and are a feature in many gardens. They are borne in large bunches, the individual flowers being large and tubular in form, and the colour of many kinds bright orange or yellow.

The climbing kinds are useful in mixed shrubberies or borders, and are particularly effective when trained on walls or fences. The usual plan adopted is to treat the deciduous kinds as pillar plants, and the larger growing as plants to cover a trellis or to mingle with the growth of trees. The shrubs are evergreen, and although few in number are among the most suitable for small borders. They are sufficiently hardy to endure the conditions generally obtaining in cottage or villa gardens, and are bright and effective for several weeks of Summer.

Florists have not effected much improvement with the *tecoma*, few hybrids of value being noted. One of the best of these is *Tecoma Smithii*, a variety raised in South Australia, and generally considered to be one of the finest garden shrubs extant.

The most suitable soil is a light loam, but in this respect the *tecomas*—or most of them—are accommodating, thriving satisfactorily in any fair garden soil. Fine specimens may be seen in the metropolitan district, growing in soils varying from a light sandy to a heavy stiff, clay loam. Like most of our cultivated plants, they fail under sour soil conditions, requiring a drained and sweet soil, even if poor and rather dry, to produce satisfactory specimens. In poor soils, well-rotted stable manure should be incorporated to a depth of 18 in., but hot forcing manures should not be used when setting out young plants.

The Autumn is the best time to plant the evergreen kinds from pots, affording the plants an opportunity of being established before the hot and dry weather sets in. In districts where severe frost is the rule, late Spring planting is best, especially for the *grandiflora* varieties. The young plants will require to be watered and tended until established when they will endure severe conditions without suffering very greatly. Deciduous kinds are often grown in the open ground by nurserymen. Any removal direct to the permanent positions for such kinds should be carried out in the dormant season.

Tecomas are propagated from cuttings of the matured growths, from roots of certain kinds—*Radicans* and its varieties, for example—and from seeds. Some kinds strike readily in winter from cuttings of the matured growths treated in the same manner as rose cuttings—*i.e.*, taken with a "heel" and inserted firmly in sandy soil in the open ground, while cuttings of others difficult to "strike" in the open are grafted on roots of the free growing kinds. Most of the *tecomas* can be readily increased by layering the branchlets, a mode of propagation frequently adopted by nurserymen. Plants are easily raised from seed if available, this being the usual means of raising *T. Smithii*, a variety which produces seed freely.

THE VARIETIES

most worthy of cultivation that are obtainable in this State, include *Capensis grandiflora*, *Radicans*, *Jasminoides*, *Stans*, *Guilfoylei*, *Madame Galen*, *Manglesii*, and *Smithii*.—"Journal of Agriculture," Victoria.

COBÆA.

If you want a good, free-climbing vine, include *Cobæa scandens*. The seeds are rather hard to start, very liable to rot in the ground unless carefully placed on edge when put in the ground. The following account of the vine is taken from "Park's Floral Magazine":—

More than one century ago, 1792, *Cobæa scandens* was introduced from the wilds of Mexico, and since that time it has been more or less cultivated

and prized as a wall, porch, and trellis vine. It is of easy propagation from seeds, and its large, graceful, hanging, purple bells, produced upon long stems which issue from the leaf-axils, are always much admired. The vine has excellent foliage with terminal tendrils, and is of wonderfully rapid growth. It becomes a favourite when its beauty is known.

Cobæa scandens has purple flowers; *C. scandens fl. albo* has large, white, bell flowers, and *C. San Salvador* is a magnificent climber, with foliage of a bright, vivid green, and strikingly effective flowers.

BOUGAINVILLEA.

The Bougainvilleas are magnificent climbers. They like a warm aspect, although they appear to thrive in almost any situation in our sunny State. Their flowers are magnificent, and they continue in bloom for a very long time. The flowers are of various shades of purple, mauve, violet, crimson, magenta, and rose-lilac. They grow easily from cuttings.

VARIETIES.

Braziliensis (bright mauve); *Conspicua* (purple shade); *Glabra* (rose-lilac); *Grandiflora* (magenta); *Hessiana magnifica* (purple); *Sanderiana* (violet red); *Refulgens* (brilliant purple mauve); *Spectabilis* (rose-lilac); *Splendens* (crimson).

CLEMATIS.

Of all the climbers the family of Clematis are the most refined and delicate in their growth and beauty of flower. They are true aristocrats among the climbers, but on account, perhaps, of their usually high price and the more than usual care sometimes required to start them, they are not seen as often as could be desired.

The principal causes of the failure of these plants, when young, are, in faulty potting, planting out, and cultivation, and not, as is generally supposed, in their grafting. When the graft has started into growth, the portion of the stem where the stock and the scion are joined should not be imbedded in the soil, and when shifting the plants into larger pots this junction should be raised 2 or even 3 in. out of the soil to fully expose the union of the graft, that it may become hardened, and thus form a woody texture. The practice should be the same in this respect, whether the graft be made of one-year-old wood or of new growth of the current season. Upon receipt of the plants from the nurserymen, it will be seen whether they are potted deeply, and if so the surface soil should be immediately removed in order to harden the graft. No roots will be found in the upper part of the pot, for the Clematis never forms surface roots, but they descend deeply into the ground, and this is clearly seen on removing a plant from a pot. It will then be found that the majority of the roots are in the drainage materials.

After the hardening process is complete, and this usually occupies three or four months, the plant will be ready for transplanting to its permanent quarters, or to be potted and grown as a specimen plant. Deep cultivation is essential in the case of ground intended for the reception of these plants. The soil in the border or bed must be stirred to a depth of 3 ft., and have incorporated with it leaf mould or well-decayed manure from a spent cucumber bed, sand, or fine gravel, and a goodly proportion of finely-broken, soft, red brick. Care should be taken that lime or mortar rubble in the smallest quantity is not present in the soil, as this constituent is most harmful. Allow a few days to elapse in order that the soil may settle down before planting, which should be done as near to the surface of the ground as is possible; at least 3 in. of the stock should be seen above the surface of the soil. A piece of zinc or tin 2 or 3 in. wide should be placed around the stem of the plant,

but not close to it; a space should be allowed as far from the stock as the rim of a 5 or 6 in. pot would be if the plant were placed in a pot of this size. The metal band will prevent soil from the border working up around the plant and burying the union of stock and graft. I have proved by experience that the principal cause of failure with the clematis is deep planting, instead of deep cultivation. With reference to plants already in position, and not in a thriving condition, it is recommended that the soil be removed from around their stems in the form of a basin. Place a piece of zinc around the stem to keep it exposed, and top-dress the border with decayed manure. Specimen plants growing in pots must not be potted deeply; the stock should be exposed at least 2 in. Deep pots of the "Long Tom" pattern should be used, and each season the plants should be given a top-dressing of some good soil, containing broken soft, red brick, with a little Ichthemic guano. Watering is an important matter, and clematis planted in borders against dwelling-houses often become dry at their roots. They should be attended to regularly, and be sometimes fed with weak liquid manure.

VARIETIES.

Jackmanni, the purple variety is best known. It is one of the large-flowered varieties, producing single and double flowers of a variety of colours. *Montana* (American Virgin Bower), pure white, a valuable climber, suitable for all parts of the State.

The small-flowered species, such as *C. paniculata*, *C. Virginia*, &c., with small white flowers in dense clusters, and *C. reticulata*, *C. coccinea*, &c., with somewhat large though still small blossoms, thrive exceedingly well.

Madame André is a crimson variety. It is a constant and profuse bloomer, and has only one defect, and that is, its dwarfish growth. After three years it may only attain a height of a little over 4 ft. Instead of a few separate vines that grow several feet in a season, it forms rather a mass of short vines that expend all their strength in blooming. Its flowers are large, about 4 in. in diameter, but never attain the size of the full-grown *Jackmanni*. Occasionally there are situations where a dwarfish grower would be preferred, and there Madame André would give perfect satisfaction. A third variety is the white *Henryi*. It is as rapid a grower as the *Jackmanni*, and is also perfectly hardy so far as tried. It begins to bloom early, and its flowers are immense in size. They seem to continue to grow after they open, until they attain a diameter of full 6 in.

They are a fine, creamy white. *Henryi* appears to be fully equal to *Jackmanni* in every desirable quality, and may surpass it in vigour and growth.

CEMENT FROM SOAP WASTE.

The "Indian Trade Journal" says:—It may be of interest to soap manufacturers to know that a striking instance of the important bearing of applied science to industry has recently been furnished at the factory of one of the largest Canadian soap manufacturers. In preparing soap an immense quantity of various residues accumulates. Some of these can be turned to commercial advantage, such as glycerine, but others have hitherto resisted any profitable application. Among the latter is carbonate of lime, which is produced in large quantities. In the course of prolonged experiments in the chemical laboratory searching for some means of utilising this waste, the above manufacturers succeeded in discovering that it could be profitably employed in the making of Portland cement, and, the process being commercially applicable, a large factory as an adjunct to the soap refineries is being erected, capable of turning out over 400 tons of cement per week.

Tropical Industries.

SISAL HEMP IN GERMAN EAST AFRICA.

A good example of what may be achieved by energy and common sense, in establishing new industries in a colony, is afforded by the work done in German East Africa in the sisal industry. For years the rich returns to be derived from planting sisal have been reiterated to farmers and planters in Queensland, but with small result. Since Mr. P. McLean introduced some plants from the Bahamas some twelve years ago, the price of sisal fibre has ranged from £50 per ton in 1902 to £37 per ton in 1907. In 1908 there was a sudden fall in price to £30 in March and £25 in June, owing to manipulation of the Manila hemp market. (See table in the Pamphlet on the Sisal Hemp Industry, issued by the Department of Agriculture and Stock.) Since then the price has again risen, until, in December, 1908, we were advised that the value of fourcroya fibre (Mauritius hemp) in England was £30 per ton, and, as this fibre is usually from £3 to £4 less in value than sisal, it follows that the price of the latter has risen proportionately.

Dr. Maxwell, in his report on the Mackay Sugar Experiment Station, just issued, deplures the want of enterprise on the part of the farmers in the district, no application having been made by them for sisal suckers wherewith to start a paying business.

Turn we to the German colony, for a contrast.

Attention has been given to sisal hemp cultivation in German East Africa since 1893 (says the "Agricultural News" of Barbados), and the increasing value of the industry is evident from the fact that the exports of fibre during 1906 were valued at £66,900, as compared with £43,900 in 1905 and £28,300 in 1904.

The industry was started by the importation of a small number of plants from Florida fifteen years ago. Machinery for the extraction of the fibre was imported in 1899, and the first exports were made in 1900. In 1904 the number of plants dealt with was 1,300,000, which yielded 624 tons of fibre, this being equivalent to an average yield of 17 oz. of fibre per plant. In the following year the average return of fibre rose to 25 oz. per plant, but in 1906 it dropped to 22 oz. It is calculated that if 800 plants per acre are grown, an annual crop of 900 to 1,200 lb. per acre should be obtained.

The machine employed for the extraction of the fibre is the one used in Yucatan, and is known as the "Molla." It costs £650, is capable of dealing with about 100,000 leaves in ten hours, and requires 48-h.p. to drive it. In order to keep this machine sufficiently employed, a plantation of at least 600,000 plants is necessary. This (allowing distances of $3\frac{1}{2}$ x $8\frac{1}{2}$ ft. between the plants) represents an area of about 310 acres.

PICKING COTTON.

There is no difficulty in picking well-ripened cotton, but much judgment is required to pick properly and to the best advantage. Where pickers are engaged to pick at so much per cwt., it is manifestly to their advantage to pick rapidly, and in so doing not to be very particular as to selecting the best, ripest, and cleanest bolls. Unless the clean cotton is kept apart from that which is stained, additional expense and loss of time are incurred by the grower and the ginner, in sorting it on arrival at the ginnery. We write from experience on this matter, as it was no uncommon thing to pick out from

10 to 20 lb. weight of stained cotton when delivered at the gin house by the farmer, and this in addition to such added trifles as stones, gravel, horse shoes, and even old boots. It is a very simple matter to so arrange the picking-bag that it shall be provided with a separate pocket, into which the stained bolls may be placed, the clean cotton going into a larger receptacle. The usual custom, in the old days of cotton-growing in Queensland, was to bag the cotton after only a few hours' exposure to the sun, and to cart it in at once to the ginnery, causing great loss to the buyer. Cotton should, after being dried, be kept in store for three or four weeks before being ginned, and turned over several times until the seed is so dry that it will crack between the teeth.

The "Cyprus Journal" has the following notes on picking:—

When the cotton-picking season begins, cotton-growers would do well to bear in mind the following hints:—

Do not leave the ripe cotton too long on the plants, but pick as soon as it is ripe.

Send all pickers, as far as possible, together to one field. In this way more careful supervision can be kept on the pickers and the cotton picked.

Stained and dirty cotton, when picked, should be put apart at once from the clean cotton. For this purpose a pocket on the picking-bag is very useful. It is easier to separate the stained cotton at the time of picking than afterwards.

Cotton, when cleaned and dried, should be kept in store from three to six weeks before being sent to the ginnery.

Cottons of different qualities should not be mixed.

SUBSIDIARY CROPS FOR CANE FARMERS.

In cane-growing, as in the case of many other rural industries, there is a time when a lull occurs in the demand for labour, and more particularly is this the case for two or three months prior to the crushing season. The greatest demand for labour in the cane-fields occurs just after the mills have closed down, and the young cane has to battle with a strong growth of weeds, and after that the cutting of the crop calls for all available hands. It is natural that as the time approaches for the cane harvest, numbers of men from all parts of the State make for the sugar plantations, and many usually arrive several weeks before the mills are ready to work. During this time they are for the most part idle, and are put to expense for living instead of earning money. This state of affairs is, to a great extent, unavoidable, yet a remedy could be found, and the remedy lies in the cane-farmer growing subsidiary crops which would be ready for harvesting at any slack time. The most accommodating of such crops is sisal hemp. This plant will thrive well on the most worn-out sugar lands, on ridgy, rocky lands no longer utilised, or even utilisable, for cane-growing. If cane-growers would take a lesson from what has been done by a planter at Childers, there would be no need for men to idle away their time waiting to be first in the field for the cane harvest. A well-grown field of sisal, after its fourth, or, in favourable circumstances, its third year, would be ready to afford employment to men two or three months before cane-cutting commences. Should it even be mature six months previously, it will take no harm if allowed to stand over until the arrival of the cane harvesters, who would thus find profitable employment during a period of enforced idleness. Fifty acres of sisal plants would furnish employment for ten cutters for a month, and additional men would be needed for carting the leaves to the machine, for decorticating, baling, &c. All this

work could be done in the few weeks preceding the cane harvest. If 100 farmers were to each plant 10 acres of sisal, there would be, within four years, 1,000 acres, affording remunerative work to 200 or 300 men. Then, the cost of a central sisal factory, as compared with a central sugar mill, amounts to a mere trifle, from £1,000 to £1,500 being ample to establish the most up-to-date mill, which could be undertaken by the farmers as a co-operative concern. The gross returns of fibre from 1,000 acres should not be less than 500 tons, which would be worth, even at present prices, from £12,000 to £13,000, and in 1907-8 would have had a value of £18,000. The cost of production would probably amount to 50 per cent. of the market value of the fibre, giving a net profit of £6,000. Thus, from two points of view, the combination of sisal-growing with cane-growing would be distinctly advantageous. There would be no idle time for the men, whilst the farmers, in addition to the value of the cane crop, would realise from £6 to £8 per acre for the sisal from a first crop, considerably more from the next, and the sale of suckers, for which there is much demand, would materially reduce the cost of production.

OTHER CROPS.

In this number of the Journal we publish an article on the Kapok, or Cotton-tree. From what is there stated, it is evident that the cultivation of Kapok would be advantageous to the sugar-planter, and the harvesting of the crop would be an additional source of income to the workers, waiting for the cane harvest to begin. Here, again, the worn-out land and areas unsuitable for sugar-growing could be profitably utilised. The Kapok trees apparently thrive with little attention, and begin to bear two years after planting. There are large areas of land in most cane-growing districts which have been thrown out of cultivation, and which are in some cases overrun with lantana and other useless vegetation. With very little trouble such areas could be placed under kapok, and the gathering of the crop would always be assured, by means of the workers gravitating early towards the plantations.

Mr. A. Molineux, late of the Agricultural Bureau of South Australia, who is an acknowledged authority on all matters agricultural, contributed, in November last, to the "West Australian Journal of Agriculture," an excellent article on "Some Minor Products for Farmers," in which he said—

"With regard to many products which might be mentioned, it will be said that the labour bestowed on their production would not be repaid in the price realised for them. That is doubtless correct, if we had something better to do with our time, but it does not pay to do nothing, and the innumerable small rills of money rolling into the general income during a year will make quite a considerable amount when added up. . . . The value of a cow and a hen is scarcely worthy the attention of a man who expects to grow 3,000 bushels of wheat by the end of the season, and yet he finds that his wife makes more profit from a dozen cows and 50 hens during the year than he gets from his large fields of grain. Why is it thus? Simply because the hens keep laying, and the cows give their dole of milk every day for the greater part of the time, whilst he gets only the one crop for all his labour. Seeing then that these smaller items make profit, it is desirable that we should give them some thought."

What applies to the wheat-grower applies with equal force to the sugar-grower. Both have all their eggs in one basket. A rust year, a drought, severe frosts, such as were experienced in October, 1908, and the bottom of the basket drops out, with the result that the farmer loses, the wheat or cane harvester loses, and neither has anything to fall back upon. But, with one or two subsidiary crops, such as are unaffected by seasons, work is provided for many hands, and profit for the farmer, even although losses are sustained on the main crop. The intelligent farmer need never be idle. When the wheat

or the cane has arrived at a certain stage of growth, there is no more labour attached to either until harvest time. Why not devote the interval to raising some such crop as we have here indicated?

"We must try," says Mr. Molineux, "to divide our labour, so that there shall be no dull round of similar occupation. It may even be a relaxation to 'knock off work and carry bricks.' We want one crop to follow another, and to learn how to harvest and even to manufacture some of those crops, so that the product shall bring approbation and honour as well as profit to us." Both these ends can be achieved by utilising the waste places of the farm for sisal, kapok, cotton, castor oil, and similar self-cultivating crops, for which a world's market exists. Then should we hear little of the common complaint of the unemployed, for there would be no "unemployed," although there might be inevitably be some "unemployable."

KAPOK.

The following information concerning the "tree-cotton" known as kapok will doubtless prove of interest to farmers and others in tropical Queensland:—

The tree is propagated either from seed or cuttings taken from a mature tree. The trees may be planted on any well-drained land, on road-sides, in back yards, or on allotments where the land cannot be profitably used for other crops, or on large estates. The only cultivation required is the clearing away of brush or undergrowth. The trees grown from seed begin to bear pods in two years, and in three years should yield a fair crop. If grown from very large cuttings, pods will be produced in the first year, but with small, thin cuttings the time before bearing is the same as for seedling trees. The crop should be harvested in the dry season, when the pods are fully ripe, and the seeds can easily be separated from the lint. So far, the only means adopted for cleaning the lint are hand labour, but we believe there is a machine on the market adapted specially for this purpose.

On an average, a mature kapok tree should yield 200 pods a year, which will furnish $2\frac{1}{2}$ lb. of lint and $\frac{1}{2}$ lb. of seed. Trees should be planted 20 ft. apart, or 108 trees to the acre. The yield from these would be 270 lb. fibre and 432 lb. seed.

As to value, Mr. H. T. Edwards, Fibre Expert, Bureau of Agriculture in Manila, says: "Cleaned kapok of best quality was quoted in New York in March, 1907, at $14\frac{1}{2}$ cents ($7\frac{1}{4}$ d.) per lb. Ordinary kapok, not thoroughly cleaned, was quoted at $12\frac{1}{2}$ cents ($6\frac{1}{4}$ d.) per lb."

The planting of kapok trees requires but little capital and a very small amount of labour. They require practically no care, and flourish on the poorest soil, and there is a constantly-increasing demand for the fibre.

We find in an article on kapok in the "Indische Mercur," 1901, that small iron mills are used in Java for cleaning the kapok, each of which produces two piculs of fibre for a day's work. (The picul in Java is equal to 137 lb.) Four women are employed for each mill. In that publication, the yield per tree of fibre is given at from 2 lb. $3\frac{1}{4}$ oz. to 111 lb., an adult tree giving 5,000 pods. In Java there are 50 plantations where kapok is produced as a subsidiary crop. On some, however, it is the principal crop. Some 38,000 bales are exported annually to Holland, Australia, China, and America, Australia taking over 8,000 bales. A bale of clean kapok weighs 37 kilos (about 80 lb.).

Here we have a product for which there is a large demand in Australia, which can be produced almost anywhere in North Queensland with little trouble and less expense.

EXPERIMENTS WITH RUBBER SEEDS.

Experiments have been carried out by Mr. H. F. Macmillan, Curator, and Mr. T. Petch, Government Mycologist, Peradeniya, Ceylon, as to the weight and germinative capacity of *Hevea* rubber seed.

The seed was collected from (A) a group of trees about twenty years old, which had never been tapped, and from (B) a group of trees about thirty years old, which were tapped regularly in 1905 (29 lb. of dry rubber being taken from eight trees in three months), occasionally in 1906, but not at all in 1907. One thousand seeds were taken from each group, and each 1,000 were divided into ten lots of 100 each, which were weighed separately. One lot from each group was planted on 14th September, and the remaining lots were planted in pairs, after weighing at intervals of a week, until all were planted. It was found that the seeds lose weight rapidly during the first fortnight after collection, and then more gradually till about the sixth week, after which time their weight remains more or less constant unless they are transferred to a drier atmosphere. The loss in weight appears to be due almost entirely to loss of water.

One thousand fresh seeds from untapped trees weighed on an average 4,126·83 gr., or 9·1 lb., and this figure agrees with results obtained by Mr. Carruthers five years previously.

The loss in weight takes place almost entirely from the kernel.

The seeds from group B weighed, when fresh, on an average 3,540·8 gr., which is 7·8 lb., as the weight of 1,000 seeds from tapped trees.

It was from these trees that Mr. Carruthers obtained his seed in 1902; thus for

Group B.

| | | |
|----------|--------------------|---------------------------------|
| 1902 ... | Untapped trees ... | Weight of 1,000 seeds = 9·1 lb. |
| 1905 ... | Trees tapped. | |
| 1907 ... | | Weight of 1,000 seeds = 7·8 lb. |

Group A.

| | | |
|----------|--------------------|---------------------------------|
| 1907 ... | Untapped trees ... | Weight of 1,000 seeds = 9·1 lb. |
|----------|--------------------|---------------------------------|

It is also stated by a planter that 1,000 seeds from his trees (fifteen years old) formerly weighed 10 lb., but now they average 7 lb., having diminished 1 lb. each year during tapping.

From the experiment it was clear that the seeds from tapped trees are smaller, weigh less per 1,000 seeds, are actually denser, but lose more weight in drying than those from untapped trees.

With regard to the germination tests, it was found that seeds from untapped trees were practically worthless if kept longer than two weeks, but that the seeds of tapped trees keep better, and both in percentage of germination and time of germination are better than seeds from untapped trees. These results, of course, apply only to germination, and as yet there is no indication as to the quality of the trees which would result from the two sets of seeds.

The full details of the experiments are given in Circular No. 11 of the *Circulars* and "*Agricultural Journal*" of the Royal Botanic Gardens, Ceylon, Vol. IV., for May, 1908. In the tables which are included for both groups the weights of the different lots of seeds and the percentage and time of germination are given. The circular concludes with a reference to the estimates of the return to be obtained by extracting oil from *Hevea* seed. Calculations have been made on the assumption that 1,000 seeds weighed 11 lb. (Wright), and 9·1 lb. (Carruthers), whereas from tapped trees, 8 lb. appears to be the more correct estimate for the weight of 1,000 seeds.

When dry and shipped to England, the kernels constitute about 50 per cent. by weight of the whole seed, and yield 42.3 per cent. of oil.

From these figures 280,000 fresh seeds or 350,000 dry seeds (yielding 700,000 kernels) = 1 ton.

The value of the kernels may be about £10 per ton.—“Bulletin of Miscellaneous Information,” Kew Gardens.

THE PESSOU CANE HARVESTER.

At a meeting, held in May last year, of the Louisiana Sugar Planters' Association, the merits of a new cane-cutting machine, known as the Pessou Cane Harvester, came up for discussion.

During the last reaping season, it is stated, this harvester underwent several practical estate trials, with satisfactory results. The cane reaped by the machine in the chief of these trials was the Demerara seedling D. 74, of which 4 acres were cut, and laid out in rows, in $4\frac{1}{2}$ hours. Four mules were used to draw the machine, and three men were employed in the work. This represents a reaping power of from 120 to 200 tons of cane per day of 10 hours.

The machine is built entirely of iron and steel. It is mounted on four wheels, two of which run on either side of the row of canes to be cut. The revolving knives may be raised or lowered to any level required, and one of the chief advantages urged in favour of the harvester is that by its means the canes may be cut much lower than by hand labour. This, of course, results in a superior return being obtained. It is claimed that the experiments so far carried out have demonstrated that the weight of cane cut per acre by the machine is 2 tons greater than that reaped by hand labour, while the yield of sucrose obtained represents a gain of 453 lb. per acre, as compared with the return given under ordinary cane-cutting methods. This is equivalent to an additional 5 per cent. in the average crop yield. Figures relating to estate work done last season by the harvester are given in support of the above claim.

It was remarked, in relation to the experiments carried out, that the use of the machine had no bad effect on the stools of cane, and the resulting ratoons show no signs of damage whatever. Alternate rows were cut by the machine and hand labour respectively, and there is little difference to be observed in the condition of the ratoon crop following, and now under cultivation.

One of the speakers who had had experience with the Pessou harvester expressed his conviction that the machine was of practical design and construction, and that in the hands of an intelligent man it could be worked with great benefit and saving to planters.

Probably the harvester will require certain modifications before it is thoroughly adapted to practical estate use, but if developed, and put on the market at a reasonable price, such a machine would, of course, result in an enormous saving of labour on large estates. This should especially recommend it to the consideration of planters in British Guiana.—“Agricultural News,” Barbados.

CUT WORMS.

A good bait for these pests is composed of 1 lb. of arsenite of soda, 8 lb. molasses or brown sugar, and 10 gallons of water, the two first ingredients to be dissolved in water. Then cut up a quantity of lucerne or other green stuff into very small bits, and moisten them with the poisoned sweet. The lucerne must not be made too wet or it will not scatter. Distribute it a few days after the land has been ploughed, when no other green food will be available for the worms. They will devour it greedily, owing to their fondness for sweets.

Vegetable Pathology.

NEMATODE ROOT GALL.*

By H. TRYON, Entomologist and Vegetable Pathologist.

The roots of the plant submitted, and, indeed, the entire portion of the axial growth whence they spring, are occupied by nodular growths, disconnected in some instances, but for the most part united in tuberous masses.

These might suggest the action of some destructive insect similar to the Root Louse (*Phylloxera vastatrix*) of the vine. We have, however, in them not the work of an insect, but the outcome of the attacks of Eel Worm (*Heterodera radicola*). However, Phylloxera and Eel Worm produce effects on the plant-economy very similar and equally baneful for it.

It will readily appear that whenever, in the plant, roots so affected take the place of ordinary sound ones, absorption on their part of moisture and nutrients is seriously interfered with, with the result that its growth is brought to an end sooner than it would otherwise happen; and should drought supervene its powers of resisting it will be seriously impaired. At the same time, the plant-constitution being weakened, there is greater likelihood of attack on the part of fungus-parasites than would otherwise happen.

CAUSE AND MODE OF OPERATION OF CAUSAL AGENT.

To briefly enter upon an account of the agent by which this root disease is caused, and its mode of operation, it may be stated as follows:—These root-tubercles owe their origin to the presence of a minute worm, and to the manifestation of its habits. This worm is of very small dimensions, and may occur in immense numbers in the soil. Ordinarily it cannot be discerned; but, should it have been placed in a few drops of clear water, it can not only be seen, but found to resemble generally in appearance a diminutive Thread Worm (the human parasite). This worm, spoken of as a "Nematode" (Gr., like a thread), possesses two successive phases in its life history. In one phase it lives exclusively within the soil, whereas in the second one its life is passed within the tissue of roots. There are both male and female Nematodes, and multiplication is effected through the production of numerous eggs. These eggs are given birth to whilst their parent is still confined within the roots of the plant affected; but either they, or the young worms that they give rise to, soon find their way into the soil in which these occur. A generation of the worms usually lives for about a month, and, ordinarily, almost the whole of this period is devoted to its internal occurrence within the roots of its host; but, under special circumstances, the life without the egg, or as a free existing animal, may be greatly prolonged.

Allusion is here made to the fact that both the Nematode and its eggs are highly resistant to the action of dryness, and, in fact, can be practically desiccated without their life being determined.

When the time and opportunity occur for the worm to establish parasitic relations with its host-plant, it brings itself in contact with its finer roots. Then it attacks these with a short but sharp dart-like organ, capable of being

* The disease Nematode Root Gall is one that victimises a large number of plants, entering into field, orchard, or garden cultivation (e.g., sugar-cane, banana, tobacco, coffee, grape-vine, paw-paw, stone and pip fruit trees, tomato, potato and other vegetables, cowpea and other pulses—accompanying nitrogen-fixing bacterial tubercles, several ornamental plants, Lantana, Sida, and various other weeds). It has for its main symptom the manifestation of numerous irregular tuberous swellings that may be found occupying every part of the root-system: and for its effect—the gradual destruction or shortened longevity of its host with an impairment of every process connected with growth and crop-production—this effect being precipitated with the occurrence of dry conditions. Commerce in plants (potatoes especially) and ignorance of both the nature and significance of this serious plant-malady are resulting in its wide dissemination, and it therefore seems expedient—anticipating fuller treatment of the subject—to give publicity to this memorandum originally prepared for the information and guidance of the Instructor in Tobacco Culture verbal amendments only been made herein.

withdrawn and exerted in turn, that is placed at its head extremity, and that is worked after the manner of a rock drill. By this means it is enabled to insinuate itself gradually into the interior of the rootlet assailed. Thereupon two things happen: (1) the plant, in response to the irritation due to its presence, produces new tissues, and thus a "gall" or "tubercle" is produced, with the result that functional energies that should be displayed in another direction are diverted to the formation of these bodies; and so not only may growth in this way be affected, but the character of the root as an absorbent organ may be largely obliterated. In the second place (2) the worm itself, or at least the female individual, undergoes wonderful transformations, until at length it becomes a flask-shaped organism, visible to the naked eye, and that may be described as a bag filled with oval eggs. Whilst gradually undergoing these changes it may, but not necessarily, move towards the outer surface of the gall; but whether or not it does this, ultimately it comes to a standstill, encysting itself in a small cavity formed in its tissue. Numbers of worms undergoing these transformations may be met within a single root-tubercle. Eventually some of the cysts or cavities become continuous with the exterior, and then two things happen: first, the worms, recently hatched, or indeed the eggs even, find their way into the surrounding soil; and, second, moisture being thus admitted to the root-gall's interior this gradually decays, and so the exit of the parasites therefrom is still further facilitated. Meanwhile, of course, the plant suffers from the deprivation of its roots; but, should soil conditions admit of it, it will continue to produce fresh roots to replace those of whose use it has been deprived, that, however, will eventually be assailed by the fresh generations of Nematodes that their predecessors have meanwhile furnished.

HOW DISSEMINATED.

Now, this serious root-destroyer does not confine its attacks to any one plant; but, on the other hand, will assail, with results equally prejudicial, almost all those constituting our cultivated crops, and, in fact, both perennial and woody plants, as well as annuals. Generally galls in the roots indicate their infestation by it; but, in some instances, only pimples betray this event.

This is a most important consideration, since it explains how the Nematode may be introduced into cultivations previously free from its presence. Thus, to effect this, a farmer has only to bring a few "pimply potatoes" to his holding, use these for culinary purposes, cast the skins on to the rubbish heap, and then distribute the resulting compost on to his land. Not only, therefore, should all plants having tubercles on their roots—in however slight degree—be excluded, but even the vegetables alluded to, affected in the manner described. Leguminous plants might have been excepted from this precaution were it not for the fact that these may be subject to the presence of these symptoms of disease, as well as to those normally occurring tubercles caused by nitrogen-furnishing organisms.

Similarly, no soil accompanying plants should be introduced from outside on to a farm, unless previously it has been disinfected by fire.

On the farm itself the disease, once present in one spot or so only, may soon be disseminated generally unless suitable precautions are taken. If disease-affected plants are ploughed in they will originate fresh centres of infestation; if horse implements are worked from Nematode-infested soil towards soil not in this condition, the parasite may be transported to the latter by their instrumentality, or even so by the soil which the horse's foot itself may convey; and, indeed, the parasite may pass spontaneously adown slopes borne along by water traversing them, as after rainfall. Commonly the disease is brought on to land from the seed bed. A sample of "nice soil" harbouring the parasite may unconsciously be selected for this purpose, with the result that almost every plant raised therein will be already infected at the time that it is set in its permanent station. This the writer has found actually to happen in two instances.

MEASURES TO BE ADOPTED IN VIEW OF ACTUAL OCCURRENCE.

If the disease be of very local occurrence or quite confined to plants originally attacked, as under the last-mentioned circumstances, and its exact limits of existence be ascertainable by the condition that these display, these should be very carefully lifted, with the object in view of removing every tubercle-affected root or rootlet from the soil, and then burnt; the site of the plant then being dosed with quicklime or watered with strong limewater.

If the disease be general on the land, and the susceptible crop to which this is devoted be an annual one, it were better "in the long run" to abandon the soil to some other purposes than that of raising this crop, and utilise another site. Meanwhile measures of quarantine should be prosecuted with respect to it, and thus preferably it should be devoted to permanent pasturage. (In this connection it should be mentioned that many weeds—*e.g.* Lantana, *Sida retusa*, "Fat Hen" (*Chenopodium*)—are equally subject to the pest with ones the object of cultivation.)

Should this not be practicable, and the area infested be limited and of especial value, the following procedure, adopted on the European continent in connection with sugar-beet culture, might be found serviceable. It is dependent on the fact that these Nematodes at one period of their existence—unlike the common free-soil-frequenting Nematodes, of which there are many kinds—must enter the tissue of a growing plant. Thus the ground is sown with plants susceptible to attack, and when these have been growing for a period less than that necessary for a second generation to arise, they are rooted up and dealt with in a way that effect the destruction of the worms that have established parasitic connection with them. This action is repeated two or three times. Of course the ground meanwhile has been kept free from weeds that might also serve to perpetuate the Nematodes. In Germany beets are used for this *trap crop*, and they are suitable, as easily removed intact.

Finally, were it possible to treat successfully worm-infested soil in the field so as to rid it of these Nematode worms or their eggs, it would fully serve all that was desired in this direction. Hitherto no suitable substance capable of economical and effectual application has been known. Recently, however, an insecticidal manure named "Vaporite" has been placed on the market by an English firm—Messrs. Strawson and Sons—regarding which it has been claimed that it possesses these desiderata. This is stocked by Messrs. Webster and Co., of Brisbane.

A NOVEL MOUSE TRAP.

A piece of an old bicycle tire and glass fruit jar are the only materials required for making this trap. Push one end of the tire in the hole, being

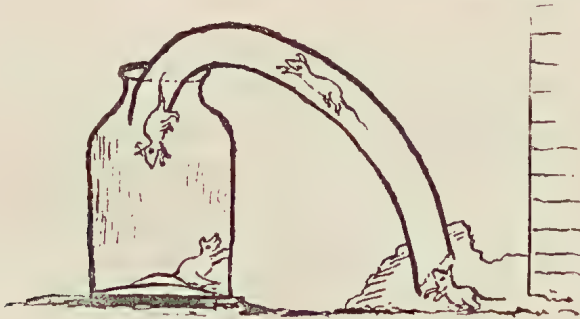

sure that there is a space left at the end so that the mice can get in. Then bend the other end down into a fruit jar or other glass jar. Bait may be placed in the jar if desired, although this is not necessary.—"Popular Mechanics."

Animal Pathology.

ACUTE TYMPANITES (HOVEN, OR BLOWN).

By SYDNEY DODD, F.R.C.V.S., Principal Veterinary Surgeon and Bacteriologist.

This is a condition occurring in ruminating animals, especially cattle and sheep, owing to the formation of gas in the rumen or paunch, and shown by a swelling in the upper part of the left flank. Hoven may be caused by any kind of food which gives rise to indigestion and fermentation. It is common in animals that have been turned into green feed early in spring, or that have broken into a field of green corn, &c. Grass or other green feed, when wet by dew or a slight shower, often disorders digestion and so induces tympanites. Also, when an animal eats its food too hastily or in too large a quantity, the action of the paunch is interfered with, the food ferments, and a large quantity of gas is formed which the animal is unable to get rid of by the ordinary method of eructation or belching, or passing the gas up from the stomach; this gas continues to form, and tympanites ensues; the animal becomes "blown." A number of other causes operate to produce hoven, but in this State the above are the chief.

The same condition may be seen when a cow is choked, as the obstruction in the gullet prevents the gas passing up from the paunch, where it accumulates. The swelling in the left flank is usually very characteristic, and, in bad cases, it can be easily observed between the point of the haunch and the last rib. If tapped by the fingers the swelling often sounds drum like, it is also very tense. The animal becomes very uneasy, and wears an anxious expression; breathing is quick, short, and difficult. If relief is not given to the animal, death may result from suffocation or rupture of the stomach or the diaphragm.

Treatment.—In slight cases driving the animal about for fifteen or thirty minutes will often give relief, or several buckets of cold water dashed against the cow's sides sometimes produce the same effect.

A very simple method is to place a thick stick or broom handle, or a piece of rope, or even straw band, smeared with grease or some other unsavoury material, in the mouth like a bit, and fasten it by tying behind the horns. The efforts of the animal to get rid of this causes a flow of saliva and swallowing movements, thus opening the gullet and allowing the accumulated gases to escape.

In very urgent cases it is necessary to allow the gas to escape without delay, and the best instrument to use is the trocar and canula, similar in shape but a little larger in bore than those for bleeding for inoculation purposes. The part selected for the puncture is a spot situated midway between the posterior edge of the last rib, the point of the haunch, and the bony processes projecting from the side of the backbone between these two points. If the trocar is sharp and the skin thin, the paunch may be punctured without any preparation; but, if the skin is very thick, it may be necessary to first make a cut through the latter, about half an inch long, with a sharp knife, and then thrust the trocar and canula into the paunch, the direction being from above, downward, inward, and slightly forward. The trocar or pointed part is withdrawn, and the tube or canula left in the flank. If the right part is struck—and this is not very difficult to arrive at—gas will rush out of the canula as soon as the trocar is withdrawn. If gas still continues to form, it may be necessary to leave the canula in position for some hours, or to insert it

again. As soon as one is satisfied that gas has ceased to escape, the canula should be removed. The trocar and canula should not be used except in cases of urgency.

If the animal is not too greatly distressed, and the "blown" condition not too pronounced, or after the greater part of the gas has been removed by the canula in bad cases, it is well to give the animal a drench (by the mouth) in order to prevent any more fermentation going on, and consequently prevent the formation of gas. Probably the best one to give in these circumstances is 1 oz. of carbonate of ammonia or 4 tablespoonfuls of aromatic spirits of ammonia dissolved in 1 quart of water. This not only prevents gas formation, but acts as a stimulant as well. Another good remedy is—liquid ammonia, 2 tablespoonfuls; oil of turpentine, 8 tablespoonfuls; linseed oil, 1 quart. Mix and give as one drench at once. When all danger is over, a laxative should be given. For this 1 lb. of Epsom salts in 1 quart of warm water may be used.

In connection with this subject it should be remembered that all the members of the sorghum family (including sorghum, millet, Kafir corn, &c.) contain, in the early stage of their growth, a substance known chemically as a glucoside. This, when it is acted upon by the stomach juices, becomes converted into prussic acid; and a number of cases, recently reported to me as having died from hoven while feeding on young sorghums, have undoubtedly died from sorghum poisoning.

Treatment in Sorghum Poisoning.—In these cases the ammonia drench should be given at once, or the animal may be made to smell the fumes of liquid ammonia for a second or so. Cold water thrown over the animal is of great assistance. As a rule, however, death occurs so rapidly that antidotes cannot be given soon enough.

Prevention is far more satisfactory than cure in sorghum poisoning, and should be carried out as follows:—

No stock should be allowed to graze on growing crops of sorghum, millet, Kafir corn, or other plant of the sorghum family. It should not be fed when green, but allowed to dry or "wilt" for a day or two. The poisonous principle disappears on drying, also when the plant reaches maturity. It is, therefore, safe, although not economical, to feed stock on green crops after they have blossomed and are forming grain.

GARLIC FOR TICK FEVER.

Mr. John Buckley, of Vrede, Orange River Colony, South Africa, writing to the "Pastoralists' Review" (15th December, 1908) says that he received a letter from his son, who is farming in the Transvaal, in which he mentions the disease called "Rhodesian Redwater." The tick fever, he says, is not the ordinary redwater. For this, the cattle are inoculated with garlic by cutting an incision in the dewlap and putting a piece of garlic bulb in. A better method, he suggests, would be to obtain extract of the garlic and inject it. Garlic is an old remedy used by the Dutch for horses when they became badly infested with ticks. His cattle are all free from ticks, as, whenever ticks make their appearance on an animal, it is at once inoculated. Garlic, he continues, is a splendid condition remedy, as well as taking all the ticks off a beast in a couple of days, according to the quantity injected. He mentions the only beast in his herd with ticks. This is an old cow, which was so badly infested that a pin's head could scarcely be placed between the insects. The garlic remedy was tried two months after the cow had calved. Only a small bit was used, yet on the second day the ticks began to fall off, and on the seventh day the cow was perfectly clean, not even a brown one, such as is usually found under the tails of horses, being left. The remedy is stated to be effectual for a whole year with one inoculation.

General Notes.

MARVELS IN CULTIVATION.

A hot controversy has been roused in the inland districts by the results of various methods of cultivation, says a contributor to the "Australasian." Certain instances are freely quoted in which the crop from the most ordinary system was at least equal to the returns from more thorough and more costly ways of treating the soil. In one case a farmer declared that he had ploughed 50 acres three times, 50 acres twice, and 50 acres once for wheat, before sowing, and he declared that the yield from the land ploughed once was equal to that from the other two places. Inquiry elicited the fact that part of this land had previously been cropped more times than the other part, but it was impossible to discover which area had the advantage. Again, I learned that all the ploughings had been carried out between the beginning of February and seed time, and, of course, if the land were in a fairly friable condition, nothing could be gained by turning it over in the dry summer weather more than once. Had one piece been ploughed in one of the soft months of the year, and again prior to seeding, it is odds on that the farmer would have a very profitable return for his extra cultivation. Other instances which are quoted, apparently with the overt intention of proving that it pays best to simply irritate the surface of the soil, are mostly unreliable when investigated. Something quite new, however, has completely superseded all other instances of what may be expected from extra cultivation. Mr. Peacock, the manager of the Bathurst Experimental Farm, claims that he is raising crops under a system which will completely revolutionise farm practice. The secret of this marvel has not yet been given to the world by its discoverer, but he has said sufficient to rouse several farmers to rather violent criticism. It is reported that one farmer has offered to stake a sum of £500 against an equal amount put up by Mr. Peacock, the farmer backing himself to produce better returns from 100 acres cultivated for wheat and oats for two seasons than can be shown by Mr. Peacock. This idea seems to open up rather a wide range for a new form of gambling, and the Government may yet have to add clauses to the Betting Act which would prevent farmers from backing their crops to go stated yields per acre. Meanwhile, sensational reports are being published setting forth the yields obtained under Mr. Peacock's system. One states that 37 bushels of wheat and 40 bushels of oats have been obtained where the charm has worked, as against 4 bushels from land cultivated in the ordinary way, the season being a very bad one in the Bathurst district. Some of Mr. Peacock's fellow-officers are just a little inclined to ridicule the tremendous secret process which has yet to be given to the world. One stated that the main feature of the new scheme is simply leaving unbroken clods on the surface, but whether the large pieces are intended to throw a shade over the young plants, or to simply encourage them to grow higher than the object nearest to them, is not stated. The inventor is meeting all his opponents, and all the ridicule which is being heaved at him, with assertions that he has discovered a kind of elixir of plant life, and it will be at least interesting to hear his description of his methods when the oracle speaks.

CURE FOR TICK POISON.

Many a valuable dog has been lost to its owner in consequence of scrub ticks. These venomous insects frequently fasten on dogs when the latter are hunting in the scrubs, and the owners, when they find their dogs sickening, rarely suspect that the ticks are at work on the animal, which is almost sure to die unless a speedy cure is resorted to.

The best treatment is usually said to be the injection under the skin of a solution of quinine. For a dog the solution should be equal to 1 to 4 gr. of quinine, and for a calf 5 to 10 gr.; and, if necessary, the injection to be repeated in twelve hours. A North Sydney resident supplies the following to the New South Wales "Farmer and Settler":—

The flat brown tick with dark stripe down the back is the most poisonous among the various kinds, and is mostly found in the tea-tree scrub. The dog suffering from tick poison first shows a weakness in the loins, and soon after loses all power in the hindquarters. As far back as 1855 Mr. Charles Smith, of Manly, brought from England a pair of harriers specially for a present to a friend residing at Brisbane Water, which soon accumulated into a pack of thirteen. The scrub lands at this time were thick with padda-melon and smaller kinds of the wallaby tribe, and the dogs used to go hunting on their own, which resulted in the death at different times of the dogs from tick poison. But a Dr. Vaughan happened to be on the spot when one of the dogs most prized was affected, his hind parts being completely powerless. The doctor, after preliminary examination, concluded that the poison had caused a locking of the whole system, and that croton oil would be the remedy. Croton oil was administered, and a speedy recovery was the result. Henceforth the tick gave no concern; croton oil proved efficacious ever after. What was effectual then should be so now. In fact, Dr. Vaughan explained, any remedy that would have a speedy action upon the system of the dog affected would be a certain cure.

REINFORCED CONCRETE.

The advantages of reinforced concrete as a material for various kinds of buildings, and for the construction of indestructible silos, have of late become so apparent that it is now used for many purposes for which timber has hitherto been employed. From the "Breeder's Gazette" we learn that farmers in America are discarding timber for straining posts of fences in favour of reinforced concrete.

The following method of constructing such straining posts is given by a farmer to the above publication:—

"The post form is made in two sections of No. 18 galvanised iron, and, when joined, form a cylinder. A cleat on one edge of each section holds them in place, and three iron rings of $\frac{1}{4}$ -in. by 1-in. tire iron hold the sections together. The top ring is solid; the other two are hinged, and fasten with a wedge-shaped pin. In one edge of one section, at the proper place, I have two holes for hinge pins, and also two $\frac{1}{2}$ -in. holes, 10 in. apart, for an iron staple as a catch for the gate latch.

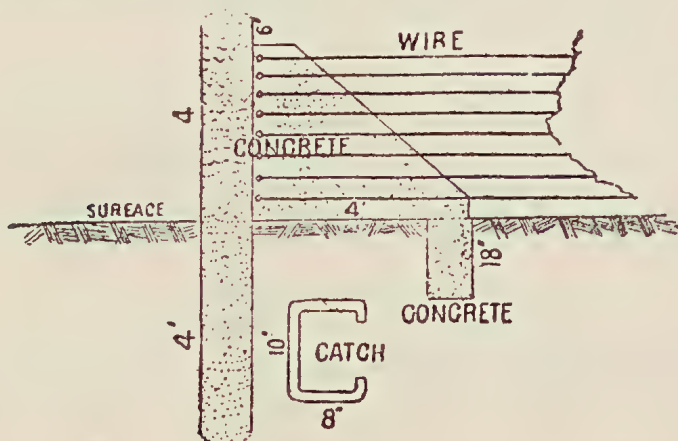

"I dig my holes 4 ft. deep, about 12 in. in diameter, and use old iron rods or other metal for reinforcement. I fill the hole with concrete, then place the form on, and continue putting in hinge pins or gate catches.

"I use a barrel of cement to a yard of gravel, and what sand the gravel needs. I work down the side of the form with a thin light tamp. I take the form off the next day carefully, and paint at once with pure cement mixed with water to the consistency of thick paint.

"My brace, or stay form, is made of two sections, as shown, held apart by a 2-in. by 6-in. and together by four bolts. Two eye-bolts ($\frac{3}{8}$ -in.) against post, and six pins, $\frac{1}{2}$ -in., with eye at one end, form holes for bringing wire through, and after stretching one simple twist over the wire will hold tight.

"I have a piece of iron, 5 in. long, welded across the end of the hinge screw hook, and have my catches made in the form of an E with the centre stem left out."

RAT POISONS.

Any effective means of destroying the rats which are so destructive in our cane fields will be welcomed, and not only by cane-growers, but by townspeople all over the State. Amongst the poisons recommended by the "Hawaiian Forester" are the following:—

Barium Carbonate.—One of the cheapest and most effective poisons for rats and mice, without taste or smell, and in the small quantities used in poisoning rats and mice is harmless to larger animals. Its action is slow but sure, and has the further advantage that the animal, before dying, if exit be possible, usually leaves the premises in search of water.

The poison may be spread on bread and butter, or more conveniently in ordinary oatmeal made into a stiff dough with one-eighth of its bulk of barytes.

Other Poisons.

1. Arsenic, $2\frac{1}{2}$ lb.; cooked rice, 6 lb.; powdered glass, 2 lb.; toasted cocoanut, 2 lb.

2. Arsenic, $2\frac{1}{2}$ lb.; cooked rice, 6 lb.; brown sugar, 2 lb.; powdered glass, 2 lb.; toasted cocoanut, 2 lb.

When these baits were tried in a rice field, the rats entirely disappeared after six days of continuous application.

3. Ratin.—The Ratin Laboratory, Gracechurch street, London, England, has put on the market a remedy, which, whilst being deadly to rats and mice, is quite harmless to all domestic animals. The success Ratin has met with is remarkable. Recently all the rats on the island of Little Cumbrae were absolutely eradicated, the island being formerly simply overrun by vermin. Equally good results have been noted in Grenada, Java, India, &c.

There are two kinds, the Ratin No. 1, which sets up a highly contagious disease, and which should, therefore, be used over large areas, and the No. 2, which is quicker acting, and which should be used where the vermin is congregated together, or after the use of the No. 1, where perhaps a few rats remain.

The poison is sold in tins of 6 oz., price 3s.; 2 lb. $3\frac{1}{5}$ oz., 12s. 6d. The 6-oz. tin of No. 2 Ratin costs 3s. 6d., and the larger tin 15s. For mice, Ratin is sold in bottles containing $2\frac{3}{8}$ oz., price 2s. 6d.

SWEET POTATO WEEVIL.

The best methods for dealing with the sweet potato weevil ("Scarabee" or "Jacobs") from attacks which have been unusually prevalent at Barbados this year—a fact generally attributed to the dryness of the season—formed the subject of a paper read before a recent meeting of the Agricultural Society of the island by Mr. H. A. Ballou, M.Sc., Entomologist to the Imperial Department of Agriculture.

It was pointed out that one of the first points to receive attention, when a crop was attacked, should be the destruction of all infected potatoes, either by burning, boiling, or burying with lime. In clearing a field of a sweet potato crop, it is important (whether the plants are infested or not) to clean up all pieces of vines and roots, so that no food supply whatever is left for the weevils. If pieces of potato are put down in heaps at frequent intervals, these serve to attract the pests, which may be collected and destroyed—by dropping into a can containing water and kerosene. Small heaps of trash lying about also serve as hiding places for the weevils, and if these are burnt up after a while, numbers of weevils would almost certainly be destroyed. If it were practicable, it would probably be effective to trash any badly infected field, and burn it over.

Another point which should receive attention is the establishment of a suitable rotation of crops on land known to have been infested with the weevil. It would naturally be most unwise to grow sweet potatoes twice in succession on the same land. It is important, too, that the crop should be gathered immediately it is ripe.—“Agricultural News,” Barbados.

HOT BEARING.

It is said that if a bearing begins to run hot it may be cooled—in many cases without stopping the engine—by oiling with good castor oil.

Times of Sunrise and Sunset at Brisbane, 1909.

| DATE. | JANUARY. | | FEBRUARY. | | MARCH. | | APRIL. | | PHASES OF THE MOON. |
|-------|----------|-------|-----------|-------|--------|-------|--------|-------|------------------------------|
| | Rises. | Sets. | Rises. | Sets. | Rises. | Sets. | Rises. | Sets. | |
| 1 | 4:57 | 6:46 | 5:21 | 6:42 | 5:40 | 6:20 | 5:57 | 5:46 | 7 Jan. ○ Full Moon 0 13 a.m. |
| 2 | 4:57 | 6:46 | 5:22 | 6:41 | 5:41 | 6:19 | 5:58 | 5:45 | 15 „) Last Quarter 4 11 „ |
| 3 | 4:58 | 6:46 | 5:22 | 6:41 | 5:42 | 6:18 | 5:58 | 5:44 | 22 „ ● New Moon 10 12 „ |
| 4 | 4:59 | 6:46 | 5:23 | 6:40 | 5:42 | 6:17 | 5:59 | 5:43 | 29 „ (First Quarter 1 7 „ |
| 5 | 4:59 | 6:46 | 5:24 | 6:40 | 5:43 | 6:16 | 5:59 | 5:42 | |
| 6 | 5:0 | 6:47 | 5:25 | 6:39 | 5:44 | 6:15 | 6:0 | 5:41 | |
| 7 | 5:1 | 6:47 | 5:25 | 6:38 | 5:44 | 6:14 | 6:0 | 5:40 | |
| 8 | 5:2 | 6:47 | 5:26 | 6:38 | 5:45 | 6:13 | 6:1 | 5:39 | 5 Feb. ○ Full Moon 6 25 p.m. |
| 9 | 5:2 | 6:47 | 5:27 | 6:37 | 5:45 | 6:12 | 6:1 | 5:38 | 13 „) Last Quarter 10 47 „ |
| 10 | 5:3 | 6:47 | 5:28 | 6:36 | 5:46 | 6:11 | 6:2 | 5:37 | 20 „ ● New Moon 8 52 „ |
| 11 | 5:4 | 6:47 | 5:28 | 6:36 | 5:46 | 6:10 | 6:2 | 5:35 | 27 „ (First Quarter 0 49 „ |
| 12 | 5:5 | 6:47 | 5:29 | 6:35 | 5:47 | 6:9 | 6:3 | 5:34 | |
| 13 | 5:5 | 6:47 | 5:30 | 6:34 | 5:48 | 6:7 | 6:3 | 5:33 | |
| 14 | 5:6 | 6:47 | 5:30 | 6:33 | 5:48 | 6:6 | 6:4 | 5:32 | |
| 15 | 5:7 | 6:47 | 5:31 | 6:33 | 5:49 | 6:5 | 6:4 | 5:31 | 7 Mar. ○ Full Moon 0 56 p.m. |
| 16 | 5:8 | 6:47 | 5:32 | 6:32 | 5:49 | 6:4 | 6:5 | 5:30 | 15 „) Last Quarter 1 42 „ |
| 17 | 5:9 | 6:47 | 5:33 | 6:31 | 5:50 | 6:3 | 6:6 | 5:29 | 22 „ ● New Moon 6 11 a.m. |
| 18 | 5:9 | 6:47 | 5:33 | 6:30 | 5:50 | 6:2 | 6:6 | 5:29 | 29 „ (First Quarter 2 49 „ |
| 19 | 5:10 | 6:46 | 5:34 | 6:29 | 5:51 | 6:1 | 6:7 | 5:28 | |
| 20 | 5:11 | 6:46 | 5:35 | 6:28 | 5:51 | 6:0 | 6:7 | 5:27 | |
| 21 | 5:12 | 6:46 | 5:35 | 6:28 | 5:52 | 5:59 | 6:8 | 5:26 | |
| 22 | 5:12 | 6:46 | 5:36 | 6:27 | 5:52 | 5:57 | 6:8 | 5:25 | |
| 23 | 5:13 | 6:46 | 5:37 | 6:26 | 5:53 | 5:56 | 6:9 | 5:24 | 6 Apr. (Full Moon 6 28 a.m. |
| 24 | 5:14 | 6:45 | 5:37 | 6:25 | 5:53 | 5:55 | 6:9 | 5:23 | 14 „) Last Quarter 0 30 „ |
| 25 | 5:15 | 6:45 | 5:38 | 6:24 | 5:54 | 5:54 | 6:10 | 5:22 | 20 „ ● New Moon 2 51 p.m. |
| 26 | 5:16 | 6:45 | 5:38 | 6:23 | 5:54 | 5:53 | 6:10 | 5:21 | 27 „ (First Quarter 6 36 „ |
| 27 | 5:17 | 6:44 | 5:39 | 6:22 | 5:55 | 5:52 | 6:11 | 5:20 | |
| 28 | 5:17 | 6:44 | 5:40 | 6:21 | 5:55 | 5:51 | 6:12 | 5:19 | |
| 29 | 5:18 | 6:43 | ... | ... | 5:56 | 5:50 | 6:12 | 5:18 | |
| 30 | 5:19 | 6:43 | ... | ... | 5:56 | 5:48 | 6:13 | 5:17 | |
| 31 | 5:20 | 6:42 | ... | ... | 5:57 | 5:47 | ... | ... | |

Answers to Correspondents.

TO BORE A HOLE THROUGH GLASS.

"YOUNG MECHANIC," South Brisbane.—

Try this. We do not vouch for success, but it is said that a hole may be bored through window glass—not plate glass—by pressing a disc of wet clay—preferably putty—upon the glass. Then make a hole in the clay of the size required, down to the bare glass. Pour in molten lead, and the lead and glass will fall out at once, leaving a clean hole.

For plate glass you want a boring tool, supplied with water and emery powder.

KAPOK.

KAPOK, Herberton.—

See article on Kapok in this issue.

BORING INSECTS.

"SUBSCRIBER, Goomboorian.—

Boring insects are usually the larvæ of beetles of various kinds. Some of these beetles are leaf-eaters, and can be destroyed by spraying with Paris green; others, again, can be destroyed by placing a cloth under the trees and then shaking the beetles on to it, when they can be swept up and killed. When the insects are in the larval or borer stage, if they are of large size, they can often be killed by inserting a fine pliable wire into their burrows, or by injecting a small quantity of kerosene or turpentine into the latter, and plugging up the latter with a piece of soft wood or clay. In any case, when borers are at all troublesome, the mature insects (beetles) should be destroyed whenever and wherever they are found. Spraying with lime, sulphur, and salt wash is a good preventive, as it acts as a deterrent to the mature insects depositing their eggs (from which the borers are evolved) on the parts sprayed. But the latest remedy talked about is a beetle discovered in Saxony, Germany; and a gentleman has been deputed by a Ceylon society to bring from Saxony a colony of beetles, provided he is satisfied that their introduction, while proving actively inimical to the "borer," may not be the introduction of an independent beetle pest. The editor of the Ceylon "Tropical Agriculturist" thinks, however, that this will be rather a difficult matter to decide in Saxony.

UNDERGROUND TANK.

D. M., Kenmore.—

Mr. A. Morry, Department of Agriculture, supplies the following information on the subject of underground tanks:—

Tank to contain 15,000 gallons will be 2,400 cu. ft., inside measurement; a convenient size would be 16 ft. inside diameter by 12 ft. in depth; this will require the removal of 108 yd. cubic of earth.

The best method of construction, if bricks and concrete materials are equally available, is the following:—

Excavate the ground to a depth of 13 ft. by 17 ft. 6 in. in diameter, keeping the sides perfectly plumb all round. Lay the floor with cement concrete 6 in. thick, in the proportion of 1 cask or 3 bags of cement to 1 yd. of clean river gravel, with a fair proportion of coarse sand; if clay is available, well pug the bottom with 3 in. of clay before laying down the concrete.

Set out the tank 16 ft. in diameter in the clear, and build up a wall all round with $4\frac{1}{2}$ -in. brickwork set in cement compo, in the proportion of 1 of cement to 3 of sand; rake out the face joints of brickwork before the cement has set hard, so as to form a key for the coating; this will leave a space of $1\frac{1}{2}$ in. all round at the back of brickwork if the excavation has been made correctly. When the brickwork has been carried up about 2 ft., fill in at the back of same with concrete as before described, and well ram the same in position, taking care, however, not to displace the brickwork; a good plan is to get as much brickwork as possible done during one day, allow it to set over night, then fill in the concrete behind same next morning, and proceed with the brickwork as before; the advantage of this plan is that no expensive or troublesome timbering is required, because, to build a circular tank of concrete only, circular timber ribs would be required, and a carpenter to fix the same each time of removal. This composite wall of brick and concrete would be 9 in. thick, and if the earth was of a clayey nature no cement facing would be required, provided that the concrete was put in soft and well rammed, but in the majority of cases it would be found necessary to cover the inside face of brickwork with a coating of cement $\frac{1}{2}$ -in. thick, in the proportion of 1 of cement to 2 of sand; this should be finished off with the wood float, an operation which can be easily performed by anyone after a little practice. Any thickness of concrete required can be put in behind the brickwork, but it should be noted that a segmental template is required for setting out the brickwork, and that the bricks should always be well wetted before use—this is a most important precaution, and must not be overlooked.

The tank could be covered with timber if desired; a few good logs would be necessary to span 16 ft., then any kind of covering could be utilised; the best cover, however, for a permanent tank of this character is undoubtedly concrete reinforced with steel or iron, on the following plan:—Rough centering should be provided for carrying the concrete until set; bearers could stretch across at suitable intervals, a few bricks being left out of the walls for the purpose; on these bearers pine boards can be placed close together. Four old steel rails should then be procured from the Railway Department, and stretched across about 3 ft. 4 in. apart, and fixed close down on the centering; between the flanges of these rails, rods of 1-in. angle iron should be placed at right angles, about 2 ft. apart, leaving a manhole in the centre, then fill in the whole with 4 in. of concrete as before described; when set, the centering can be withdrawn, and the cover will be found complete, and will last practically for ever; the iron or steel reinforcement being embedded in the concrete will be effectually protected. No trees should grow within 20 ft., or the roots may cause damage; some trees should be kept even farther away. Most of the work can be done by ordinary farm labour; if a bricklayer was engaged he would be occupied about seven days, with the usual labourer's assistance; 3,500 bricks would be required, costing, in Brisbane, about 50s. per 1,000, without carting—400 equals a load; 16 yd. of gravel; 16 casks of cement for concrete, 4 casks for brickwork, 5 casks for cementing inside—total, 25 casks at 14s.; bricklayer's wages, £4 4s.; iron and timber, say £5; or a total cost for materials, except gravel, and labour, except ordinary farm labour, and carting, of £35.

The cost of galvanised iron tanks to store the same quantity would reach about £70.

CHOPPED SUGAR-CANE AS FODDER.

J. PORTER, Cairns.—

Sugar-cane can be chaffed in an ordinary strong chaffcutter. The cane chaff, 25 lb. cane-top chaff, and 5 lb. of bran; or 18 lb. lucerne chaff, 25 lb. feeding value than maize ensilage. The bran cannot be replaced by sugar-cane chaff, and, if no bran can be obtained, a proportionately larger amount

of lucerne has to be fed to supply the necessary amount of nitrogen. If the whole cane is chaffed up, more will have to be used than of cane-top chaff.

A cow yielding about 10 quarts of milk requires a ration of 10 lb. lucerne chaff, 25 lb. cane-top chaff, and 5 lb. of bran; or 18 lb. lucerne chaff, 25 lb. cane-top chaff.

Molasses can be added to the chaff in small quantities, but cannot replace the chaff itself.

FAILURE OF POTATO CROP.

“POTATOES,” Bell.—

July is too early to plant potatoes in any district except close to the seaboard or above the frost line. The cause of the potatoes not bottoming is often due to planting a late-maturing, unsuitable kind, and to the plants being subjected to excessive heat, such as you mention having experienced. The result is that the plants become drawn, and waste their energy in forming haulms instead of tubers.

You can plant potatoes in February if seasonable weather is experienced, but an early-maturing kind should be selected, such as Early Rose, Early Vermont, or Brownell's Beauty. The last-named will be found one of the best all-round sorts for your district.

THE PUMPKIN BEETLE.

At the request of the Entomologist, it is notified that the article which appears under his name on the subject of the Pumpkin Beetle in our issue of January last is disclaimed by him.

The author should have been stated to be the Assistant Entomologist.

The Markets.

PRICES OF FRUIT—TURBOT-STREET MARKETS.

| Article. | DECEMBER. | |
|--|-----------|------------|
| | Prices. | |
| Apples (Eating) per case ... | 5s. | to 6s. |
| Apples (Cooking), per case ... | 5s. 6d. | to 6s. 6d. |
| Apricots, per quarter-case ... | 3s. 6d. | to 4s. 6d. |
| Bananas (Cavendish), per dozen ... | 1½d. | |
| Bananas (sugar), per dozen ... | 1d. | |
| Grapes, per lb. ... | 1d. | to 1½d. |
| Lemons (Italian), per case ... | 18s. | to 20s. |
| Lemons (Sydney), per case ... | 10s. | to 12s. |
| Mangoes, per case ... | 5s. | to 7s. |
| Nectarines, per case ... | 3s. 6d. | to 4s. |
| Passion Fruit, per quarter-case ... | 1s. 6d. | to 2s. |
| Papaw Apples, per quarter-case ... | 2s. | |
| Peaches, per quarter-case ... | 3s. | to 5s. |
| Pears, per quarter-case ... | 6s. | to 7s. |
| Plums (best), per quarter-case ... | 4s. | to 5s. |
| Pineapples, rough, per dozen ... | 8d. | to 1s. |
| Pineapples, smooth, per dozen ... | 1s. 6d. | to 2s. 6d. |
| Rock Melons, per dozen, according to size ... | 2s. | to 4s. |
| Tomatoes, per quarter-case ... | 1s. 6d. | to 3s. |
| Water Melons, per dozen, according to size ... | 2s. | to 8s. |
| Tomatoes, per quarter-case ... | 2s. | to 4s. |

SOUTHERN FRUIT MARKET.

| | | |
|---|---------|------------|
| Apples (Tasmanian) eating, per case ... | 10s. | to 12s. |
| Apples (Tasmanian) cooking, per case ... | 9s. | |
| Apples (Local), per case ... | 12s. | |
| Apricots, per quarter-case ... | 5s. | |
| Apricots (Tasmanian), per quarter-case ... | 5s. 6d. | |
| Bananas (Queensland), per bunch ... | 1s. 6d. | to 4s. 6d. |
| Bananas (Queensland), per case ... | 8s. 6d. | to 9s. |
| Cherries, per quarter-case ... | ... | |
| Grapes (Queensland), black, per 12-lb. box ... | 5s. | |
| Grapes (Queensland), white, per 12-lb. box ... | 4s. | |
| Lemons, per gin case ... | 18s. | |
| Mandarins, per case ... | 10s. | |
| Mangoes, per case ... | ... | |
| Nectarines, per half-case ... | 5s. | |
| Oranges (Local), per case ... | 10s. | |
| Oranges, Navel, per case ... | 12s. | to 14s. |
| Passion Fruit, choice, per quarter-case ... | 4s. | to 6s. |
| Pears, per case ... | 5s. | |
| Peaches, per case ... | 7s. | |
| Pineapples (Queensland), choice, Queen, per case ... | 8s. | to 9s. |
| Pineapples (Queensland), medium, per case ... | 6s. 5d. | to 7s. 6d. |
| Pineapples (Queensland), choice common, per case ... | 5s. | to 6s. |
| Pineapples (Queensland), Ripley Queen, per case ... | 6s. | to 8s. |
| Plums, per gin case ... | 4s. | to 5s. |
| Rock melons (Local), per case ... | 6s. | to 7s. 6d. |
| Water melons (Queensland), choice, per dozen ... | 15s. | |
| Water melons (Queensland), small to medium, per dozen ... | 4s. | to 8s. |
| Water melons (Local), medium, per dozen ... | 4s. | to 10s. |
| Tomatoes (best), per quarter-case ... | 3s. 6d. | to 4s. |

Farm and Garden Notes for March.

FIELD.—Take every opportunity of turning up the ground in readiness for sowing and planting winter crops. The main crop of potatoes should at once be planted. As the growth of weeds will now be slackening off, lucerne may be sown on deeply-cultivated soil. The latter should be rich and friable, with a porous sub-soil. The land should be thoroughly pulverised. Do not waste time and money in trying to grow lucerne on land with a stiff, clay sub-soil. Prepare the land a couple of months before sowing, care being taken to cross-plough and harrow before the weeds have gone to seed. This ensures a clean field. Sow either broadcast or in drills. In the former case, 20 lb. of seed will be required; in the latter, 10 lb. A good stand of lucerne has been obtained with less quantities. Lucerne seed is worth from £2 16s. to £3 5s. per cwt. Should weeds make their appearance before the plants have sent down their tap-roots, mow the field. Before they can again make headway enough to do any damage, the lucerne will be strong enough to hold its own against them. Harrow and roll the land after mowing. Gather all ripe corn. It is now too late to sow maize, even 90-day, with any certainty of harvesting a crop of grain. Rye grass, prairie grass, oats, barley (in some districts, wheat), sorghum, vetches, carrots, mangolds, and Swede turnips may be sown. In Northern Queensland, sow tobacco-seed, cow-pea, Carob beans, sweet potatoes, opium poppy, &c. Sow Anatto, Jack fruit, and plant Kola-nut cuttings. Some temperate zone vegetables may be planted—such as egg-plant, potatoes, &c. Coffee-planting may be continued. Harvest Kafir corn and paddy.

FLOWER GARDEN.—Now is the time to plant out bulbs. A complete garden could be furnished with these charming plants, which are to be had in every colour and variety. Amongst the many are—Amaryllis, anemone, arum, babiana, crinum, crocus, freesia, ranunculus, jonquils, iris, ixias, gladiolus, narcissus, Jacobean lilies, tigridia, tritonia.

All bulbs like well-drained, somewhat sandy soil, with a plentiful admixture of leaf mould. Herbaceous plants and annuals which it is intended to raise from seed should be sown this month. Such are—Antirrhinums (snap-dragon), asters, cornflowers, dianthus, larkspurs, daisies, cosmos, candytuft, lupins, gaillardias, godetia, mignonette, poppies, pansies, phlox, sweet peas. Cannas now planted will require plenty of food, in the shape of liquid manure. Put in cuttings of carnations. Chrysanthemums require attention in the way of disbudding, staking, watering with liquid manure, &c. Growers for exhibition will thin out to a few buds, and protect the flowers from rain and sun. Dahlias should be looking well. To secure fine blooms, disbudding should be done.

Now, as to climbers which may now be planted. These are—Allamanda Schottii (beautiful yellow), Antigonon leptotus, a charming cerise-coloured climber; Aristolochia elegans, handsome as an orchid, and easily grown; Aristolochia ornithocephala (Dutchman's Pipe), very curious, large, always attracts attention; Asparagus plumosa, grows in any shady place; Beaumontia grandiflora, splendid white flower, grand for a fence, will grow 50 ft. high; Bignonias of several kinds; Bougainvilleas, with their splendid leafy, pink and purple flowers, rapidly clothe a fence or unsightly shed with a blaze of blossom; Quisqualis indica, a fine creeper, flowers pink, changing to white; Wistaria, purple and white. Most beautiful is the Bauhinia scandens, rarely seen about Brisbane. We grew a plant of this climber at Nundah, and it soon closed in the front of the veranda for a distance of over 80 ft. The leaves are very small, and in the flowering season it presents almost a solid

mass of beautiful round bunches of blossom, something like the hawthorn bloom—pink and white. It seeds freely, but the seeds are difficult to germinate, and when they have produced a plant it is still more difficult to rear it. A rooted sucker from the main stem will, in all probability, grow.

KITCHEN GARDEN.—During this month a very large variety of vegetable seeds may be sown in readiness for planting out where necessary in the Autumn, which begins on the 20th March. All unoccupied land should be roughly dug, and, where required, add well-decomposed manure. Transplant cabbage, cauliflower, celery, &c. Sow French beans, beet, carrot, turnips, radish, cabbage, cauliflower, cress, peas, mustard, &c. Former sowings should be thinned out and kept clear of weeds. Mulch round melon and cucumber beds with a good dressing of long stable manure, as it assists in keeping the fruit clean and free from damp. Cucumbers, melons, French beans, and tomatoes should be looked for every day and gathered, whether required or not, for if left on the vines to perfect their seeds the plants will soon cease to be productive, or will form inferior, ill-shaped, and hence unsaleable fruit.

Orchard Notes for March.

By ALBERT H. BENSON, M.R.A.C.

THE SOUTHERN COAST DISTRICTS.

The marketing of the main crop of pineapples will continue to occupy the attention of growers; and as it is probable that the plantations have been allowed to get somewhat dirty during the previous month, they should be cleaned up as soon as ever the crop has been got off. The fruit of the new crop of citrus fruit will be showing signs of ripening towards the end of the month; and as the fruit during this period of its growth is very liable to the attack of insect pests of various kinds, it is important that steps be taken to prevent loss arising from this cause as far as possible.

Large sucking moths of several kinds attack the fruit as soon as it shows signs of ripening; and as they always select the first fruit that shows signs of colouring, it is a good plan to gather a few forward fruit and to ripen them up quickly by placing them on a barn floor, and covering them up with bags or straw. They will turn colour in a few days, and develop the characteristic scent of the ripening fruit. The fruit so treated should be hung up in conspicuous places in the orchard as trap-fruit, as not only will it attract the moths, but also the fruit flies. The moths will be found clustered round the trap fruits in large numbers, and can then be easily caught and destroyed. Fruit fly will also puncture such fruit; and if the fruit is destroyed before the larvæ reach maturity, a later crop of these insects is prevented from hatching out. Fruit flies may also be caught in large numbers by means of such artificially-ripened fruits. The fruits are smeared with tangle-foot, and hung about the orchard. The fly, attracted by the colour, settles on the fruit, and is caught in a similar manner to house flies on specially-prepared sticky paper. These simple remedies, if carefully carried out, will result in the destruction of large numbers of sucking moths and fruit flies.

The yellow peach moth that does such damage to peaches in Spring, and that attacks corn, sorghum, cotton bolls, custard apples, and many other plants and fruits, often does a lot of damage to citrus fruits. It acts in a very similar manner to the second and later generations of the Codling moth of pomaceous fruits, in that it lays its eggs where two fruits touch, under the shelter of a leaf or the fruit, at the stem end of the fruit, and, in the case of

navel oranges, in the navel itself; in fact, anywhere that there is a likelihood of the egg not being disturbed. The egg hatches out into a small spotted caterpillar, which eats its way into the fruit, causing it to ripen prematurely, and fall off. Where two fruits touch, it often eats into and destroys both, and it frequently leaves one fruit to go and destroy a second. It is a very difficult insect to deal with, owing to the number of fruits and plants on which it lives; but, as far as citrus fruits are concerned, the best remedy is undoubtedly to spray the fruit with a remedy that will destroy the young insect when it starts to eat the skin of the fruit. Bordeaux mixture has been found efficacious, but I am of opinion that spraying with Paris green and lime, Kedzie's mixture, or arsenite of lead will also have good results. The latter poison is, in my opinion, well worth giving a thorough test, as it sticks to the fruit and leaves for a long time. Bordeaux mixture, either alone or in conjunction with Paris green or Kedzie's mixture, is, however, a good remedy, as not only will it destroy the larvæ or prevent the moth from attacking the tree, but it is also the best remedy for black brand or melanose, as well as tending to keep all other fungus pests in check. Fight fruit-fly systematically—both by means of the sticky fruit already recommended, and by gathering all fly-infested fruit, such as guavas, late mangoes, kumquats, &c., as well as any oranges or mandarins that may have been infested, as if kept in check now there will be little less throughout the season. A little fruit will be marketed towards the end of the month. See that it is gathered and sweated for seven days before marketing, and don't gather it too immature. Beauty of Glen Retreat mandarins are often gathered and marketed as soon as they show signs of colouring. They are then as sour as a lemon, and anyone who is unlucky enough to buy them will steer off mandarins for some time to come. This variety should not be gathered till thoroughly ripe, as when marketed in an immature state it spoils the market, as it puts people off eating citrus fruit.

Clean up the orchard after the summer rains, and have everything ready for the marketing of the crop. See that there is a good supply of clean, dry, case timber on hand, as one of the greatest sources of loss in shipment is packing fruit in green cases.

Strawberry-planting can be done throughout the month. Plant such berries as Federation on the lowest ground, and Aurie, Anetta, Trollop's Victoria, Glenfield Beauty on warm, well-drained soils. Prepare the land thoroughly, so that it is in perfect tilth, and in a fit state to retain moisture well; as on this, as much as anything, the success of the crop depends. Where new orchards are to be planted, get the land ready—not the clearing, which should have been done months ago, but the working of the land, as it is advisable to get it thoroughly sweetened before putting the trees in.

THE TROPICAL COAST DISTRICTS.

The Notes for February apply equally to March. See that bananas are netted—keep down weed growth, and market any sound citrus fruits. Clean up the orchards as well as possible, and keep pines clean. Get land ready where new orchards are to be set out, as tree-planting can be done during April and May. Pines and bananas can still be planted, as they will become well established before winter.

THE SOUTHERN AND CENTRAL TABLELANDS.

Finish the gathering of the later varieties of deciduous fruits, as well as grapes. Clean up the orchard, and get ready for winter. Get new land ready for planting; and where there are old, dead, or useless trees to be removed, dig them out, and leave the ground to sweeten, so that when a new tree is planted to replace them the ground will be in good order.

In the drier parts, where citrus trees are grown, keep the land well worked, and water where necessary.

Agriculture.

STATE FARM, ROMA.

THE EXPERIMENTS WITH WINTER CEREALS, CARRIED OUT AT THE FARM DURING 1908.

R. E. SOUTTER, Manager, State Farm, Bungeworgorai, Roma.

METEOROLOGICAL.

After the heavy rains of March a dry spell set in. During April only .07 rain was registered, whilst there was none in May. These adverse conditions were partially relieved in June, $\frac{1}{2}$ inch being recorded. This promoted germination on sandy soils, but on the clayey and heavier soils was of no benefit. It was not until the latter part of July that the droughty conditions were wholly dispelled, and from that time till crops were harvested no lack of moisture occurred. The precipitation did not result in quick growth immediately, owing to the continuance of cold weather, but with the advent of warmer weather the manner in which the crops responded was marvellous, and the ultimate results far better than could be reasonably expected.

The following is the rainfall recorded from 1st April to 30th November, 1908:—

| Month. | Wet days. | Total rainfall. |
|-----------|-----------|-----------------|
| April | 1 | .07 |
| May | ... | ... |
| June | 2 | .50 |
| July | 7 | 1.27 |
| August | 5 | .73 |
| September | 2 | 1.21 |
| October | 6 | 2.55 |
| November | 7 | 2.47 |
| Total | 30 | 8.70 |

SERIES A.

Permanent blocks.—Second season's results:—Area, 1 acre each. Variety of wheat experimented with, Bunge No. 1. Preparation of seed bed consisted of one double discing, two ploughings, and two harrowings. Seed was drilled in and harrowed.

Block No. 1.—Ploughed 4 in. deep. Sown 12th May. Germination uneven. Harrowed once, and rolled during growth. Harvested, 26th November. Yield, 13.4 bushels.

Block No. 2.—Ploughed 4 in. deep. Sown 12th May. Germination uneven. Harrowed once during growth. Harvested, 24th November. Yield, 14.2 bushels.

Block No. 3.—Ploughed 4 in. deep. Sown, 12th May. Germination uneven. Harrowed twice during growth. Harvested, 26th November. Yield, 14.1 bushels to acre.

Block No. 4.—Ploughed 4 in. deep. Sown, 11th May. Germination fairly even. Harrowed thrice during growth. Harvested, 21st November. Yield, 17.6 bushels.

Block No. 5.—Ploughed 5 in. deep. Sown, 11th May. Germination fairly even. Harvested, 21st November. Yield, 17.0 bushels. This block is to be ploughed 1 in. deeper each succeeding year, till a depth of 12 in. has been reached.

Block No. 6.—Ploughed 5 in. deep. Sown, 11th May. Germination fairly even. Harvested, 20th November. Yield, 20.9 bushels to acre.

Block No. 7.—Ploughed 6 in. deep. Sown, 9th May. No cultivation after seeding. Harvested 20th November. Yield, 26.1 bushels to acre.

Block No. 8.—Ploughed 6 in. deep. Rolled once during growth. Germination even. Harvested, 18th November. Yield, 25.7 bushels to acre.

Block No. 9.—Ploughed 6 in. deep. Harrowed once during growth. Germinated evenly. Harvested, 18th November. Yield, 26.0 bushels to acre.

Block No. 10.—Ploughed 6 in. deep. Sown, 9th May, at rate of 40 lb. seed to acre. Germinated evenly. Harvested, 18th November. Yield, 26.7 bushels to acre.

Block No. 11.—Ploughed 6 in. deep. Sown, 9th May, at rate of about 18 lb. seed to acre. Germination fairly even. Harvested, 19th November. Yield, 18 bushels to acre.

N.B.—A gully intersects this block, and influences results considerably.

Block No. 12.—Ploughed 6 in. deep. Sown, 9th May. Harrowed twice during growth. Germination fairly even. Harvested, 19th November. Yield, 20.2 bushels.

Block No. 13.—Ploughed 6 in. deep. Sown, 9th May. Drilled in 4 in. (approx.) deep. Even germination. Harvested, 19th November. Yield, 19.4 bushels to acre.

Block No. 14.—Ploughed 6 in. deep. Sown, 11th May, 3½ in. deep. Germination even. Harvested, 19th November. Yield, 19.6 bushels to acre.

Block No. 15.—Ploughed 7 in. deep (approx.). Sown, 11th May. Germination fairly even. Harvested, 20th November. Yield, 18.6 bushels.

Block No. 16.—Ploughed, 8 in. deep. Rotation crop of panicum every second year. Sown, 11th May. Harvested, 20th November. Yield, 18.4 bushels.

Block No. 17.—Ploughed 8 in. deep. Cropped with pumpkins every second year. Sown, 11th May. Germination fairly even. Harvested, 21st November. Yield, 18.6 bushels.

Block No. 18.—Ploughed 8 in. deep. Cropped with rape every second year. Sown, 12th May. Germination uneven. Harvested, 26th November. Yield, 17.8 bushels.

Block No. 19.—Ploughed 8 in. deep. Cropped with cowpea every second year. Sown, 12th May. Germination uneven. Harvested, 26th November. Yield, 15.4 bushels.

Block No. 20.—Ploughed 8 in. deep, bare fallow every other year. Sown, 12th May. Germinated unevenly. Harvested, 26th November. Yield, 15.6 bushels to acre.

Remarks.—In order that the foregoing results may not be misleading, I may mention that the soil in blocks 1, 2, 3, 19, and 20 is much inferior to that found in 4, 5, 6, 15, 16, 17, and 18, which is again inferior to that in blocks 7, 8, 9, 10, 11, 12, 13, and 14.

SERIES B.

Scientific soil culture. (Prof. Campbell's method.)

Location.—Paddock B, Block 2. Area, 8 acres. It is to be regretted that nothing further has been learned as to the value of this system this season, due to the fact that the work carried out last season was rendered futile by the heavy rains experienced in February and March last, washing off the surface soil and cutting numerous gullies through the blocks. This necessitated, in order to obtain sufficient soil to cover seed, the turning up of the subsoil over a great portion of the area. Heavy rains since experienced have further decreased the possibility of producing crops here; indeed, have made the ground so broken as to practically debar the working of implements over it.

Cultivation.—Preparation of seed bed since previous crop was removed, has necessitated four ploughings, three double discings, ten harrowings, and

one packing. The condition of the soil in this block at seeding time was the reverse of what it would have been had nothing interfered with the proper working of the system, hence the results obtained are valueless, as preparation of seed bed is the chief factor. The variety sown, results, &c., are as follows, viz. :—

J. Brown.—Area, 4.6 acres. Sown, May, 3rd week. Harvested, November, 4th week. Yield, 10.3 bushels to acre. Grain poor.

Remarks.—Crop very uneven, owing to uneven quality of soil. Height ranging from 2 ft. 6 in. down to 9 in.

Bunge No. 1.—Area, 2.9 acres. Sown, August, 1st week. Harvested, November, last week. Yield, 8 bushels to acre.

Remarks.—Soil much inferior to that in portion allotted to J. Brown. Crop uneven, height ranging from 2 ft. down to 9 in. Grain very fair.

Paddock C.—Block 2. Area, 10 acres.

Alluvial Flat.—Not sown.

This block, which lies in a depression on west bank of creek, was also rendered unfit for sowing this season by the heavy rains in the early part of the year, which caused the Bunge to overflow its banks, and rush over this area.

The ill effects will not be so lasting here as on Block 2, Paddock B (though much more soil was removed), as the soil is much deeper and is only subject to scour when floods occur.

Cultivation of this area, owing to the dry spell which supervened, the rains, which did the damage, was delayed until August, when it was again ploughed, which did not result in a tilth being obtained to warrant seeding; indeed, at time of writing, it is not in a condition to receive a crop, though it has been cultivated (ploughed) twice since.

SERIES C.

Area of blocks, half an acre.

The cultivation of the area devoted to these blocks has been carried out in a similar manner to that advocated by Prof. Campbell, with the exception that the sub-surface packer was not employed, and it was hoped by so doing to ascertain, by comparing the results here with those obtained where it was used, the real value of the implement. Owing to the fact that the experiments which entailed the use of the implement were rendered worthless by untoward circumstances, nothing in this direction has been accomplished, though the further testing of a number of varieties has been made.

Preparation of seed bed.—1907.—Bare fallow, maintained in a state of good tilth. Twice ploughed, twice double disced, and harrowed five times.

1908.—Twice ploughed, once double disced, and harrowed five times.

Cost per acre, 27s. 6d., approx.

The variety tested with results, &c., being as follows:—

Bunge No. 1.—Sown, 4th August. Earing, October, 2nd week. Harvested, 27th November. Yield, 23 bushels to acre.

Hermitage No. 2.—Sown, May, 1st week. Earing, October, 2nd week. Harvested, December, 2nd week. Yield, 16.6 bushels to acre.

Remarks.—A good deal of grain was lost, owing to crop having been flattened down by a storm; rather long in straw.

Arnantka—Durum wheat.—May, 1st week. Earing, October, 2nd week. Harvested, December, 2nd week. Yield, 11.2 bushels to acre.

Moulds.—Sown, May, 1st week. Earing, October, 2nd week. Harvested, December, 2nd week. Yield, 16.9. A fair quantity of grain was lost owing to crop having been blown down by storm.

Farrer's Durum—Macaroni.—Sown, May, 1st week. Harvested, December, 2nd week. Yield, 10.8 bushels to acre.

Plover.—Sown, May, 1st week. Earing, October, 2nd week. Harvested, December, 2nd week. Yield, 16.3 bushels to acre. Rather short straw, which is a desirable quality.

Turkey—Durum wheat.—Sown, May, 1st week. Earing, October, 2nd week. Harvested, December, 2nd week. Yield, 13.6 bushels to acre.

Rymer.—Sown, May, 1st week. Earing, October, 1st week. Harvested, December, 2nd week. Yield, 13.0 bushels to acre. Worthy of further trial. Short straw.

Velvet Don—Durum.—Sown, May, 1st week. Earing, October, 2nd week. Harvested, December, 2nd week. Yield, 13.0 bushels to acre.

Sussex.—Sown, May, 1st week. Earing, October, 1st week. Harvested, December, 2nd week. Yield, 21.5 bushels to acre.

Alpha.—Sown, 23rd June. 14 lb. to acre. Earing, September, 4th week. Harvested, December, 2nd week. Yield, 22.8 bushels to acre. To all appearances this season, this wheat, which was introduced from Western Australia, is a very desirable variety to grow. Prior to a storm, which resulted in not much more than half the grain being garnered, it gave promise of giving the heaviest yield of any variety grown. The reason of its falling down was not wholly due to a defect in the plant, but, in a great measure, to the fact that the drills were sown 14 in. apart, and so the plants afforded each other very little protection or support. It should prove a good hay wheat—fine, and stout in straw, flag very coarse, head compact, well filled, does not shed grain, large, of pleasing appearance.

Should this variety come through a rusty year it will be an acquisition to the varieties now in favour. After subsequent field tests the results in this particular will be made known.

Manitoba (Roma Mill Seed).—Sown, May, 1st week. Earing, October, 2nd week. Harvested, December, 2nd week. Yield, 15.8 bushels to acre. Grain pinched. This variety has again demonstrated that it is wholly unsuitable for this district.

SERIES D.

Quarter Acre Blocks.

Cultivated in a similar manner to Block C, with this exception: that double discing was substituted for the final ploughing, the ground not having set here as elsewhere, being of a more loamy nature. All seed sown was drilled in as deep as machine would permit, and was above ground eight days from sowing, notwithstanding the very limited amount of rain.

Bobs.—Sown, May, 1st week, 25 lb. to acre. Earing, August, 3rd week. Harvested, November, 1st week. Yield, 24.9 bushels to acre. Medium long straw, rather weak, sheds easily, also weathers. Liable to be frosted if sown too early in low situations.

Bunyip.—Sown, May, 1st week, 25 lb. to acre. Earing, August, 2nd week. Harvested, November, 1st week. Yield, 22.5 bushels to acre. This is the earliest wheat grown here, and was slightly frosted; has a short stout straw, compact well-filled head, though liable to rust; escapes it if sown at right time, through its earliness. Has proved fairly consistent up to the present.

Federation.—Sown, May, 1st week, 25 lb. to acre. Earing, August, 3rd week. Harvested, November, 1st week. Yield, 26 bushels to acre. This is a short-strawed wheat: it has proved susceptible to rust here, but withstands droughty conditions well. Grain of good appearance, round, plump.

Australian Crossbred, 73.—Small sample of seed obtained from Chapman Experimental Farm, Western Australia. Sown, May, 2nd week, 12 lb. to acre. Earing, August, 3rd week. Harvested, November, 1st week. Yield, 32.2 bushels to acre. Medium long straw, stout, good stripper, does not shed easily, stools well. Grain good appearance.

Yandilla King.—Seed obtained from South Australia. Sown, May, 2nd week, 20 lb. to acre. Earing, September, 2nd week. Harvested, November, 1st week. Yield, 25.4 bushels to acre. This is a short-strawed wheat, good stooler, heads short, well filled, and from results obtained in South Australia is a very suitable wheat for any locality. Grain small, plump.

Nhill.—Procured from same source as previous mentioned variety. Sown, May, 2nd week, 15 lb. to acre. Earing, September, 1st week. Harvested, November, 1st week. Yield, 37.6 bushels to acre. Medium long straw, stout, ear long, and droops sufficiently to throw off moisture, and still not prove detrimental when stripping; glumes close, does not shed easily, strips well. Grain large.

Comeback, "Pratts."—South Australia. Sown, May, 2nd week, 28 lb. to acre. Earing, September, 4th week. Harvested, November, 2nd week. Yield, 35.48 bushels to acre. Medium short straw, stools well, good stripper. As this and the two previous mentioned wheats have not been grown here previously, nothing can be said as to their rust-resisting qualities.

Garton's Red King (Imported 1908).—Sown, May, 1st week, 20 lb. to acre. Earing, October, 3rd week. Harvested, December, 2nd week. Yield, 3.5 bushels to acre. Grain sown very weevily, germination poor, crop very thin. Rusty. Straw stout, strong, very flaggy. Coarse flag, bald, head close, compact. Very slow in maturing. Requires sowing much earlier than was done here this season.

Garton's New Era (Imp. 1908).—Sown, May, 1st week, 26 lb. to acre. Earing, October, 3rd week. Harvested, December, 2nd week. Yield, 10.4 bushels to acre. Ears slightly bearded with coarse awns, black. Head extremely long, and would, under suitable conditions, produce very heavy yield. Remarks applied to previous wheat apply here.

MISCELLANEOUS BLOCKS AND VARIETIES.

Correll's No. 2.—Area, 4 acres. Sown, 1st May. Earing, October, 2nd week. Harvested, December, 1st week. Yield, 14.4 bushels to acre. This was the first crop sown, and one of the last to mature, and had it not been for the rains experienced during September, no grain would have been harvested. Where others gave promise of fair yields of grain, this variety was only a few inches high, clearly demonstrating that it is not a suitable kind to continue growing in large areas, as it is too slow in responding to showers for this district.

Correll's No. 2.—Area, 4 acres. Sown, 1st May. Earing, October, 2nd week. Harvested, December, 1st week. Yield, 16 bushels to acre. Seed very mixed. Further remarks as applied to Correll's No. 2.

Cretain—Durum wheat (bearded).—Sown, 2nd May. Earing, October, 2nd week. Harvested, December, 1st week. Yield, 10.4 bushels to acre. Poor stooler, straw fine, strong, nearly solid, beard causes great inconvenience both in stripping and winnowing. More suitable for coastal cultivation.

Kubanka—Durum wheat (bearded).—Sown, 5th May. Earing, October, 3rd week. Harvested, December, 2nd week. Yield, 6.1 bushels to acre. Portion of the block on which this variety was growing is black soil, and germination there did not take place till September, whereas on the lighter portion the wheat appeared above ground ten days from sowing. Though the yield is low, this variety may be considered the best of its class when grown under favourable conditions. Stools well, large head and grain, strong, medium, stout, straw tall. Like all bearded wheats, it is troublesome to strip and winnow.

Le Huguenot—Durum wheat (Bald Medeath).—Sown, 24th June. Earing, October, 1st week. Harvested, December, 2nd week. Yield, 4.1 bushels to acre.

This variety has again proved that it is not worth continuing with, and is about the poorest of its class, and, notwithstanding that it has the advantage of being beardless, it is far more difficult to clean and strip than others.

Bunge No. 1.—Area, 4.5 acres. Sown, 23rd June. Earing, September, 2nd week. Harvested, November, 3rd week. Yield, 22.2 bushels to acre. The soil in this block ranged from a rich sandy loam to a raw sand. On the first-mentioned kind the crop grew to a height of 5 ft. 6 in., and the estimated yield was between nine and ten bags to the acre. Over the remainder the crop was only about 2½ ft. high, and very thin.

Baltic Red (Local variety).—Area $\frac{2}{3}$ of an acre. Sown, 23rd June. Earing, October, 3rd week. Harvested, December, 2nd week. Yield, 6 bushels to acre. This and the afore-mentioned crop, as will be seen, were sown on the same day in the same field. When the Bunge No. 1 gave promise of a four-bag crop, this variety was only a few inches high, and very poor.

Samples.—Small areas of about 1/100 of an acre were sown with new varieties, and those varieties previously grown here, whose behaviour did not warrant larger areas being sown.

Lot 1.—Seed obtained from Roseworthy Agricultural College, &c. Sown, 13th May, at rate of 15 lb. to acre. Harvested, December, 2nd week.

| Variety | Yield per acre. | | Remarks. |
|----------------------|-----------------|--|--------------------|
| | Bushels. | | |
| Hermitage. | S. Aust. No. 50 | ... 8.5 | Smutted and down. |
| | " 51 | ... 9.3 | Down; fairly good. |
| | " 52 | ... 13.6 | Good; erect. |
| | " 53 | ... 13.6 | do. |
| | " 54 | ... 11.2 | do. |
| | " 55 | ... 12.3 | Smutted. |
| Bald Medeah | ... 4.5 | Worthless. | |
| Bobs | ... 12.9 | Good, shed slightly. | |
| College Purple | Straw 16.1 | Good. | |
| Comeback C... | ... 12.5 | Good, shed slightly. | |
| Cumberland | ... 10.7 | Fair. | |
| Federation | ... 24.6 | Splendid heads, short straw, grain very good. | |
| Hudson's E. P. Straw | 24.2 | Worthy of further trial. Grain good. | |
| Jumbuck | ... 16.0 | Down as a result of storm. Large grain. | |
| Leak's R. R. | ... 13.2 | Large grain; pinched. | |
| Marshall's No. 3 | ... 12.1 | Blown down; slightly pinched. | |
| Red Fife D | ... 6.1 | Wholly unsuited to the district. | |
| Silver King | ... 12.2 | Large grain; pinched. | |
| Stanley D | ... 7.6 | Poor; very pinched. | |
| Steinwedel Imp. | ... 14.1 | Sheds blown down. | |
| Wallace | ... 12.2 | Blown flat. | |
| Warden Haywheat | ... 11.8 | Other variety would have proved more suitable for hay. Medium early. | |
| White, Essex C | ... 8.6 | Very poor; late. | |
| White, Fife D | ... 9.7 | Poor; grain pinched; late. | |
| 99 C, 23 A2 | ... 13.0 | Stout erect straw. Mid-season. | |
| 40 K2 | ... 13.6 | do. | |
| K3, 91 | ... 10.6 | Very poor stooler. Mid-season. | |
| J. C. 157 | ... 13.5 | Stout erect straw. Mid-season. | |

Lot 2.—Previously grown here. Sown, 13th May, 28 lb. to acre. Harvested, December, 2nd week. Ground practically a clay-pan.

| Variety. | Yield per Acre.
Bushels. | Remarks, |
|---------------------------|-----------------------------|---|
| Belotourka | 7.6 ... | Durum var., long straw. |
| B. Don | 5.3 ... | do. Medium. Coarse straw. |
| 13 Budd's Early | 10.5 ... | Stood up well; grain plump. |
| Gharnooka (Yellow) | 5.3 ... | Bearded; seed originally obtained from America. |
| Jonathan | 7.6 ... | Poor grain; pinched. Mid-season. |
| Lofthouse | 7.6 ... | Poor grain; pinched; late. Wholly unsuitable. Introduced from America. |
| Morocco | 9.6 ... | Durum wheat; short straw; coarse, bearded. |
| Odessa " | 8.4 ... | Poor grain; pinched. Too slow in maturing. |
| Russian Ulks | 7.6 ... | Grain poor; late. |
| Schneider | 10.0 ... | Grain fair mid-season. |
| Select Fife | 4.6 ... | Very pinched; too slow; seed from America. |
| Tarragon | 8.4 ... | Grain pinched; rather late. |
| Minnesota B. S. | 4.0 ... | Very poor grain; very pinched. Wholly unsuitable. Original seed from America. |
| Power's Fife | 7.2 ... | Poor; late. |
| Crossbred No. 12 | 7.6 ... | Poor stooler; medium early. |
| " 25 | 10.0 ... | Fairly good; " |
| " 33 | 12.2 ... | Grain good; " |
| " 50 | 10.7 ... | Grain fair; " |
| " 53 | 10.5 ... | do. " |
| " 91 | 7.2 ... | Very thin; " |
| " 121 | 9.2 ... | Grain fair; " |
| " 181 | 10.7 ... | do. " |
| " 343 | 8.8 ... | Grain medium; weak straw; medium early. |
| " 348 | 11.5 ... | Grain good; medium early. |
| " 349 | 14.3 ... | do. medium early; good straw. |
| " 353 | 12.2 ... | Grain good; medium early. |

Usher's Rust Resister.—Sown, 4th August. Earing, October, 4th week. Harvested, December, 2nd week. Yield, 5.3 bushels to acre. Seed received from Transvaal Department of Agriculture, Pretoria. Nothing definite can be stated as to the variety proving suitable or otherwise here, as the seed was sown very late in the season, and has not yet become acclimatised. Is fully three weeks longer in coming to maturity than Bunge No. 1. Seeds of other varieties were received, but, owing to the unfavourable conditions at ordinary seeding time, were not sown.

OTHER CEREALS.

BARLEY.

This crop has again proved a partial failure, owing to the lack of surface moisture when required. The yields were considerably reduced by a heavy rain storm accompanied by hail and wind, which blew down the crop and threshed out the grain. The varieties sown and results obtained were as follow, viz. :—

Hallett's (Imp. Chev. Barley, $\frac{1}{2}$ -acre).—Sown, May. Earing, September, 2nd week. Harvested, November, 4th week. Yield, 5 bushels to acre. Fully half of this crop was lost.

"Carters" Malting Barley (Area, 1 acre).—Sown, 1st May. Earing, September, 3rd week. Harvested, November, 4th week. Yield, 10.7 bushels to acre. A fair quantity of grain was lost over this block.

Invincible.—Area, 1 acre. Sown, May, 1st week. Earing, September, 2nd week. Harvested, November, 4th week. Yield, 8.5 bushels to acre. Very little grain was lost here, but crop was very thin, hence difference in yield.

OATS.

Two varieties were sown, the seed of which was obtained from Garton's, Limited, Warrington, England. For preparation of seed bed see Series D.

Results, &c.

Universal Oat (white)—area, $\frac{1}{4}$ -acre.—Sown, May, 1st week. Harvested, October, 4th week. Yield, 15 bushels to acre. Straw and flag very coarse. Height, 4 ft. Crop very poor till after September rains.

Bountiful Oat (black)—area, $\frac{1}{4}$ -acre.—Sown, May, 1st week. Harvested, December, 1st week. Yield, 7 bushels to acre. Very poor; probably due to proximity of trees in adjacent paddock.

Hybridising.

1907 Crosses.—Owing to the depredations of grasshoppers, only five plants came to maturity out of the seed sown. Two crosses exhibited characteristics totally different to either parent. Further sowings will be made of these next year.

1908.—This season this branch of work has been continued, and confined to a few of the leading varieties, which possess undesirable characteristics, such as being too fine or long in straw, too open in glumes, &c. The elimination or reduction of these undesirable features has been aimed at, and when crossing the selection has been made with this object in view.

16 Bunge No. 1, which has proved the best all-round wheat on the farm, is inclined to grow too tall on rich soil, and, as the straw is fine, has a tendency to come down in a storm. In an endeavour to overcome this feature, 293 crosses have been made with three short-strawed varieties. This variety is also open in the glumes, the result being that very little rain causes discolouration. Eighty-three individual crosses with three close-glumed varieties have been made with a view of producing a plant without this defect.

In addition to the foregoing, 184 other crosses have been made with six good varieties. These 560 new crosses will afford interesting comparisons next season, and, it is to be hoped, certain valuable data.

FUNGOID DISEASES.

Rust.—A little rust made its appearance on the most susceptible variety in the early part of September, but the conditions were evidently not favourable to its development, and it disappeared, and was not in evidence again till the 1st week in December, when it appeared in a virulent form on the only two green crops at the time—viz., Garton's Red King and Garton's New Era.

Smut.—Garton's Universal and Bountiful Oats, the only variety of this cereal grown, were badly infested with smut. This is the first season that ball smut has been found here, and was present in crops resulting from seed received in sample packets which originally came from South Australia and other sources. The varieties infested were:—Leak's R. R., South Australian wheats Nos. 50 and 55. As these crops were the last removed, all grain previously harvested is free of spores. The area utilised by infested varieties contains only $\frac{1}{30}$ of an acre, and is in next season's fallow block, so that the danger of infection from this source is reduced to a minimum, providing only treated seed is sown.

OTHER PESTS.

Grasshoppers were present in the early part of the season, but did no material damage to field crops.

White Ants.—Isolated plants were killed by these.

Caterpillars.—A small caterpillar which finds its way into the stalk of wheat at the top node, causing the ear to dry off, was noticed.

SUMMARY OF RESULTS OF OBSERVATIONS DURING 1908.

Unsuitability of varieties from grain point of view.

Fife wheats.—These wheats are too late in maturing for this portion of the State at least, as the summer sun causes the crop, in five years out of six, to ripen off before grain is filled, and the berry has the same appearance as that resulting from a very rusty crop.

Durum wheats.—Up to the present these wheats have been amongst the lowest yielders we have. The only year in which they gave a payable return as a whole was a wet one, and, as they were introduced on account of their reputation as dry-belt wheats, this is disappointing. Even had they proved as suitable in this respect as some of our own, it is improbable that they would be extensively cultivated, as the beards (awns) render harvesting a much slower operation than it is with bald varieties.

Suitable variety.—Wheats having either a short straw or a medium long, stout straw, with very little flag, and which mature quickly, are evidently the most suitable varieties for this climate. The shorter-strawed varieties are preferable, as they probably require less moisture to grow, have less surface for evaporation, do not obtain so much momentum in a strong wind, thereby reducing the danger of shedding, and are not nearly so liable to being blown down by storms. Ability to resist rust is also a feature of importance.

Best time for sowing.—May is the most suitable month for sowing most varieties in most situations in this district. Quick maturing kinds such as Bobs, Bumyip, Federation, Bunge, &c., in low-lying situations, should not be sown till the latter part of the month, unless they can be grazed off in the event of being too forward, this being necessary in order to avoid being frosted. This season an August sowing of Bunge No. 1 yielded 23 bushels to the acre, but the year before last, rust, which reduced the yield of the Maranoa so much, made its appearance this month, and, had the conditions been favourable to its propagation this season, very little would have been obtained, if any, from this area, whereas those sown in May would have been very little reduced.

Seed.—The same results have been obtained from sowing $\frac{1}{4}$ and $\frac{1}{2}$ bushels to the acre (drilled). Though nothing conclusive has been arrived at, the following has been noted:—The thinner seeded areas were the most weedy, and the crops were more inclined to be blown down by storms. This was due to the fact that, in order to sow the limited quantity, it was necessary to stop up every other tube, making the drills 14 in. apart. This distance prevented the plants supporting one another as they do when sown 7 in. apart. Grading of seed has given the following results, viz.: A more even seeding; as a result, plants are not overcrowded, germination is more even, stronger plants are produced, which establish themselves under conditions which would prove fatal to those originating from pinched grain.

A PROLIFIC WHEAT.

During 1908 the Department of Agriculture and Stock distributed, gratis, several varieties of seed wheat to farmers in the wheat districts of the State, for the purpose of introducing and establishing new and proved kinds, and many reports on the results have been received from the recipients. Amongst

others, is a report from Mr. A. M. Griffin, of Roma, who last season sowed 1 bushel of No. 1 Bunge wheat. The seed was sown on the 25th May, and the crop harvested on the 10th November, 1908. The yield from this single bushel amounted to 75 bushels, being the best yet recorded for this or any other variety distributed by the Department. Mr. Griffin, in his report, says that the methods of cultivation adopted on the State Farm are of great value to wheat-growers, and he recommends proceeding on the same lines, with special reference to the after-cultivation of growing crops by frequent harrowings. He is so satisfied with the result of his experiment that he intends sowing 50 acres of this wheat in the coming season.

A NEW VALUABLE CLOVER PLANT.

New Zealand "Farm" describes a new clover plant (*Hedysarium coronarius*), commonly known as Maltese Clover, which has been placed on the market by Mr. W. C. Callaghan, of Wellington, N.Z. It is a native of Southern Italy, but is peculiarly adapted to New Zealand soils, and grows strong and healthy, with richly-coloured flowers. The stems are succulent and full of saccharine matter, and are much relished by stock. The clover surpasses other fodders on account of its nutritious qualities, and produces abundant crops on poor, sandy soils, and will continue bearing for many years. Mr. Callaghan has been experimenting for some time, and assures us that the plant is easily grown, and attains a height of 4 ft. The clover grows from 18 in. to 2 ft. in two months, and can be cut twice a year. There is no better plant for ensilage purposes, and for hay it is excellent. The seeds should be sown in drills 18 in. to 2 ft. apart. Bees are particularly partial to the fragrant flowers of this clover.

It is exceptionally valuable for sheep and lambs, as it contains a considerable quantity of saccharine matter, which is an important factor in food for stock.

We have consulted the Colonial Botanist, Mr. F. M. Bailey, F.L.S., on this plant. He says it has long been cultivated in France, and in Calabria, in Italy, where it grows to a height of 4 ft. It will not, however, bear the climate of Queensland, where it has often been tried, but has invariably proved a failure.—Ed. "Q.A.J."

FARM CROPS AS FOOD FOR STOCK.

By J. C. BRUNNICH, Agricultural Chemist.

At the time when green feed is getting scarce, farmers often desire to know what quantities of dry fodders and concentrated food stuffs have to be supplied to stock in order to keep them in good condition. For this purpose I have prepared some tables, which are partly based on the results of our own analyses, and partly on the results obtained elsewhere, giving the amounts of **digestible nutrient in various foods.**

The question of **feeding farm stock** was dealt with fairly fully in my 19th lecture on the "Chemistry of the Farm, Dairy, and Household" ("Queensland Agricultural Journal," October, 1907), and I can only repeat here that the animals have different powers of digestion, and that ruminants digest much larger proportions of the nutrients in the foods than non-ruminants, like horses and pigs. Green foods, again, are, as a rule, more easily digested than dry foods.

Table I., taken from the lesson already mentioned, shows the quantities of nutrients required per day and per 1,000 lb. of live weight. An ox at rest

requires only about $\frac{3}{4}$ lb. of proteins (nitrogenous compounds, flesh-formers) per day, whereas the same beast, heavily worked, would require nearly $2\frac{1}{2}$ lb. of proteins.

Pigs, in their earliest period of growth, require a more nitrogenous feed than when they get older. A pig nine to twelve months old would require, as it weighs about 250 lb., one quarter of the quantities given, say, $\frac{1}{4}$ of 3 lb. = $\frac{3}{4}$ lb. of proteins, $\frac{1}{4}$ of 18.3, or 4.6 lb. of carbohydrates.

The quantities of digestible nutrients, as digested by ruminants, are given on **Table II.**, from which table any food ration can be calculated.

We find, for instance, that in 100 lb. of lucerne hay we get $12\frac{1}{2}$ lb. of protein, nearly 48 lb. of carbohydrates, which include digestible fibre, starch, sugars, &c., and 1.2 lb. of crude fat.

To make calculation still easier, I prepared a further table (**Table III.**) which gives the quantities of each fodder in pounds required to supply a proper ration to a milking cow of 950 lb. to 1,000 lb. live weight, and yielding about 25 lb. of milk (nearly 10 quarts) a day. We will see from the table that, for instance, 26 lb. of lucerne hay are required to supply the amount of total solid matter, only 20 lb. are required to supply the necessary protein, and 33 lb. are required to supply all the carbohydrates. The reason is that lucerne contains almost too much nitrogenous material compared with the carbohydrate nutrients, the nutritive ratio being from 1:2.2 (green lucerne) to 1:3.2 (lucerne hay), whereas a cow requires a ratio of about 1 part of digestible proteids to 5.4 parts of digestible carbohydrates, including fat.

If we feed, therefore, cows entirely on lucerne, we supply more nitrogenous material than necessary, which, therefore, may go to waste, and it is advantageous to feed a lesser quantity of lucerne hay, and supplement with such feeds containing comparatively higher amounts of carbohydrates and fats, or of a wider nutritive ratio, like wheat straw, oaten straw, bush hay, potatoes, &c.

A simple application of the tables will show how rations may be mixed from various feeds; and, if the price of the food is known, it is easy to calculate the cost of each ration.

A closer study of the tables will prove the great value of the by-products—bran, pollard, and oil cakes—as cattle foods.

How little value prickly pear leaves have as feed for cattle is shown by the enormous quantities which have to be consumed by an animal in order to get a complete ration, and only if this feed would be supplemented with concentrated foods like oil cake the beasts could be kept in good condition.

Correspondents have repeatedly inquired about the value of sugar-cane tops, and it will be seen that the value of chop-chop made from green sugar-cane tops comes very closely in its feeding value to maize and sorghum.

Saltbush, again, has a very high feeding value.

Table I.

FEEDING STANDARDS.

Digestible Nutrients Required per Day and per 1,000 Lb. Live Weight.

| | — | Lb. of : | Total
Dry Matter. | Proteins. | Carbohydrates. | Fat. | Nutritive
Ratio. |
|-------------------------------|--------|----------|----------------------|-----------|----------------|------|---------------------|
| Milch cow | | ... | 24.0 | 2.5 | 12.5 | .4 | 1 : 5.4 |
| Ox at rest | | ... | 17.5 | .7 | 8.0 | .2 | 1 : 12 |
| Ox heavily worked | | ... | 26.0 | 2.4 | 13.2 | .5 | 1 : 6 |
| Horse moderately worked | | ... | 22.5 | 1.8 | 11.2 | .6 | 1 : 7 |
| Horse heavily worked | | ... | 25.5 | 2.8 | 13.4 | .8 | 1 : 5.5 |
| Fattening pigs, 2 to 3 months | | ... | 44.0 | 7.6 | 28.0 | 1.0 | 1 : 4 |
| " " 5 to 6 " | | ... | 33.0 | 4.3 | 22.3 | .6 | 1 : 5.5 |
| " " 9 to 12 " | | ... | 26.0 | 3.0 | 18.3 | .3 | 1 : 6.4 |

Table II.

COMPOSITION OF FOODS.

Total Dry Matter and Digestible Nutrients in 100 Lb. of Food.

| | Total
Dry Matter
in 100 Lb. | DIGESTIBLE NUTRIENTS. | | | Nutritive
Ratio. |
|----------------------------|-----------------------------------|-----------------------|---|------------|---------------------|
| | | Proteins. | Carbohydrates,
Fibre, Starch,
and Sugars. | Crude Fat. | |
| <i>Hay and Straw—</i> | | | | | |
| Lucerne | 91.4 | 12.5 | 37.8 | 1.2 | 1 : 3.2 |
| Paspalum | 91.9 | 5.6 | 43.0 | .6 | 1 : 7.9 |
| Prairie grass | 91.1 | 7.8 | 43.5 | .8 | 1 : 5.8 |
| Canary grass | 88.7 | 8.7 | 40.0 | .9 | 1 : 4.8 |
| Wheat straw | 90.4 | .4 | 36.3 | .4 | 1 : 93 |
| Oaten straw | 90.8 | 1.2 | 38.6 | .8 | 1 : 33.7 |
| Bush hay | 93.5 | 3.5 | 49.2 | 1.0 | 1 : 14.7 |
| <i>Ensilage—</i> | | | | | |
| Sorghum | 23.6 | .8 | 13.6 | .4 | 1 : 18.1 |
| Maize | 21.6 | 1.1 | 11.5 | .3 | 1 : 11.0 |
| <i>Green Fodders—</i> | | | | | |
| Bush grass | 38.9 | 3.0 | 18.3 | .4 | 1 : 6.4 |
| Couch grass | 34.5 | 3.6 | 15.8 | .2 | 1 : 4.5 |
| Paspalum | 27.2 | 2.0 | 12.8 | .2 | 1 : 6.6 |
| Lucerne | 23.8 | 3.8 | 7.8 | .3 | 1 : 2.2 |
| Cowpea vines | 21.1 | 3.4 | 12.5 | .5 | 1 : 4.0 |
| Sweet potato vines | 12.4 | 1.4 | 5.1 | .2 | 1 : 4.0 |
| Sorghum | 32.1 | 1.7 | 15.4 | .3 | 1 : 9.5 |
| Maize | 25.4 | 1.3 | 13.5 | .2 | 1 : 10.8 |
| Sugar-cane tops | 28.8 | 1.4 | 14.8 | .4 | 1 : 9.8 |
| Prickly-pear leaves | 5.6 | .3 | 2.3 | ... | 1 : 7.7 |
| Saltbush | 20.8 | 2.9 | 7.8 | .4 | 1 : 3.1 |
| <i>Roots and Tubers—</i> | | | | | |
| Potatoes | 21.1 | .9 | 16.3 | .1 | 1 : 20.6 |
| Sweet potatoes | 28.9 | .8 | 23.7 | .3 | 1 : 30.5 |
| Mangolds | 9.1 | 1.1 | 5.4 | .1 | 1 : 5.1 |
| Swedes | 11.4 | .8 | 7.0 | .1 | 1 : 9.0 |
| Pumpkins | 9.1 | 1.0 | 5.8 | .3 | 1 : 6.5 |
| <i>Grains—</i> | | | | | |
| Maize | 88.0 | 9.9 | 62.1 | 4.7 | 1 : 7.3 |
| Wheat, plump | 88.5 | 9.5 | 49.9 | 1.4 | 1 : 5.6 |
| Wheat, shrunken | 91.7 | 13.7 | 47.6 | 1.4 | 1 : 3.7 |
| Barley | 90.0 | 9.6 | 63.5 | 2.1 | 1 : 7.1 |
| Oats | 89.0 | 9.2 | 47.3 | 4.2 | 1 : 6.2 |
| Peas | 89.5 | 16.8 | 51.8 | .7 | 1 : 3.2 |
| Kafir corn | 90.7 | 7.5 | 70.5 | 2.6 | 1 : 10.2 |
| <i>By-products—</i> | | | | | |
| Wheat bran | 88.3 | 11.2 | 42.2 | 2.5 | 1 : 5.1 |
| Wheat pollard | 88.3 | 12.2 | 53.4 | 3.8 | 1 : 5.1 |
| Cocoa-nut oilcake | 85.9 | 16.4 | 42.4 | 9.7 | 1 : 3.9 |
| Cotton-seed meal | 90.2 | 41.1 | 15.4 | 11.0 | 1 : 1.0 |
| Molasses | 75.0 | ... | 55.0 | ... | ... |

Table III.
FOOD EQUIVALENTS.

Pounds of Digestible Nutrient Required by a Cow of 950 to 1,000 Lb. Live Weight Yielding up to 25 Lb. Milk Daily.

| | Total
Dry Matter. | Proteins. | Carbohydrates
and Fat. |
|--|----------------------|-----------|---------------------------|
| | 24.0 | 2.5 | 13.4 |
| These Digestible Nutrients are contained in Lb. of Food. | | | |
| <i>Hay and Straw—</i> | | | |
| Lucerne | 26 | 20 | 33 |
| Paspalum | 26 | 45 | 30 |
| Prairie grass " | 26 | 32 | 30 |
| Canary grass | 27 | 29 | 32 |
| Wheat straw | 26 | 625 | 36 |
| Oaten straw | 26 | 208 | 33 |
| Bush hay | 26 | 71 | 26 |
| <i>Ensilage—</i> | | | |
| Sorghum | 103 | 312 | 92 |
| Maize | 111 | 227 | 110 |
| <i>Green Fodders—</i> | | | |
| Bush grass | 62 | 83 | 70 |
| Couch grass | 70 | 69 | 82 |
| Paspalum | 89 | 125 | 101 |
| Lucerne | 101 | 66 | 158 |
| Cowpea vines | 114 | 74 | 98 |
| Sweet potato vines | 194 | 178 | 239 |
| Sorghum | 75 | 147 | 83 |
| Maize | 95 | 192 | 96 |
| Sugar-cane tops | 83 | 178 | 98 |
| Prickly-pear leaves | 430 | 833 | 582 |
| Saltbush | 115 | 86 | 150 |
| <i>Roots and Tubers—</i> | | | |
| Potatoes | 114 | 278 | 72 |
| Sweet potatoes | 83 | 312 | 55 |
| Mangolds | 264 | 227 | 248 |
| Swedes | 210 | 312 | 186 |
| Pumpkins | 264 | 250 | 206 |
| <i>Grains—</i> | | | |
| Maize | 27 | 25 | 18 |
| Wheat, plump | 27 | 26 | 25 |
| Wheat, skrunken | 26 | 18 | 26 |
| Barley | 27 | 26 | 20 |
| Oats | 27 | 27 | 24 |
| Peas | 27 | 15 | 25 |
| Kafir corn | 26 | 33 | 17 |
| <i>By-products—</i> | | | |
| Wheat bran | 27 | 22 | 23 |
| Wheat pollard | 27 | 20 | 22 |
| Cocoa-nut oilcake | 28 | 15 | 21 |
| Cotton-seed meal | 27 | 6 | 33 |
| Molasses | 32 | ... | 24 |

BIGGENDEN STATE FARM.

The State Farm at Biggenden, situated some 54 miles from Maryborough, on the Gayndah line, although not of very large extent, holds a foremost place amongst similar State institutions. The manager, Mr. D. MacPherson, notwithstanding the prevalence of dry weather, has succeeded in producing some admirable crops of maize, sorghum, cowpeas, kafir corn, &c., as may be seen by the accompanying illustrations.

The soil of the farm is generally black and fertile. On such a soil was produced the fine crop of maize here depicted. It was only ten weeks old when the photograph was taken, and promised a very heavy crop.

The red kafir corn was about four months old, and not quite ripe. It was grown on similar soil and under similar weather conditions as the maize, and was estimated to yield 60 bushels per acre, the previous yield having reached 70 bushels.

A sorghum crop, not shown here, was somewhat backward last season owing to dry weather after sowing, and was expected to yield only 15 tons of fodder per acre, whereas, on previous occasions, 30 tons have been harvested. The crop from this field has been mixed with cow-pea and chaffed for ensilage, which process is shown in the illustration. Here horse-power is used, the same animals which cart the crop being used in the three-horse gear. The silo is constructed of reinforced cement, and will contain 60 tons of silage when full. The Biggenden climate appears to be well adapted to the cultivation of the sun-flower, judging by the large size attained by the Giant Russian Sun-flowers in the manager's hands—from 16 to 18 in. in diameter. There is a good market in Australia for sun-flower seeds, as for all other oil seeds, but prices for produce are too low to enable the white grower to successfully compete with cheap-labour countries. Sesamum, castor-oil, candle-nut, olive, linseed, cotton-seed, peanut, oil palm, and many other oil-producing plants thrive admirably in this State, but the cost of production prohibits production on a profitable commercial scale.

In the case of pea-nuts, candle nuts, oil palm nuts, and other hard-shelled nuts, the purchaser requires them to be shelled. There is, we understand, a machine for shelling oil palm seeds, but it is not favoured by the natives of West Africa. The shelling of candle-nuts by hand would effectually put them out of the market in Brisbane, where only £10 per ton can be obtained for them. Castor-oil beans are worth about £9 per ton.

The other photographs give a good general idea of the farm buildings and the manager's house.

ROTATION OF CROPS.

All who are engaged in farming pursuits know what is meant by rotation of crops, but how many in this State practise it? One main reason for the neglect in making different crops follow each other in different years on the farm may be traced to the wonderful fertility of most of the arable land in farming districts. So rich are many of these soils that before a good crop of wheat can be raised from them, a series of crops of maize, potatoes, or roots must be taken off, otherwise coarse straw will be produced at the cost of the grain. On such soils oaten straw is often so thick and coarse as to be useless for hay-making, and when wheat is at last grown heavy crops have been harvested year after year for more than twenty years without the use of manure, or recourse being had to rotation. But, on many soils, rotation is very desirable. On these, if potatoes are made to follow potatoes year after year, the ground eventually becomes so infected with disease that only scabby tubers can be produced. It is the same with clover. After a time, unless

Plate XVIII.



MAIZE, TEN WEEKS OLD, BIGGENDEN STATE FARM.

Plate XIX.



RED KAFIR CORN, FOUR MONTHS OLD, BIGGENDEN STATE FARM.

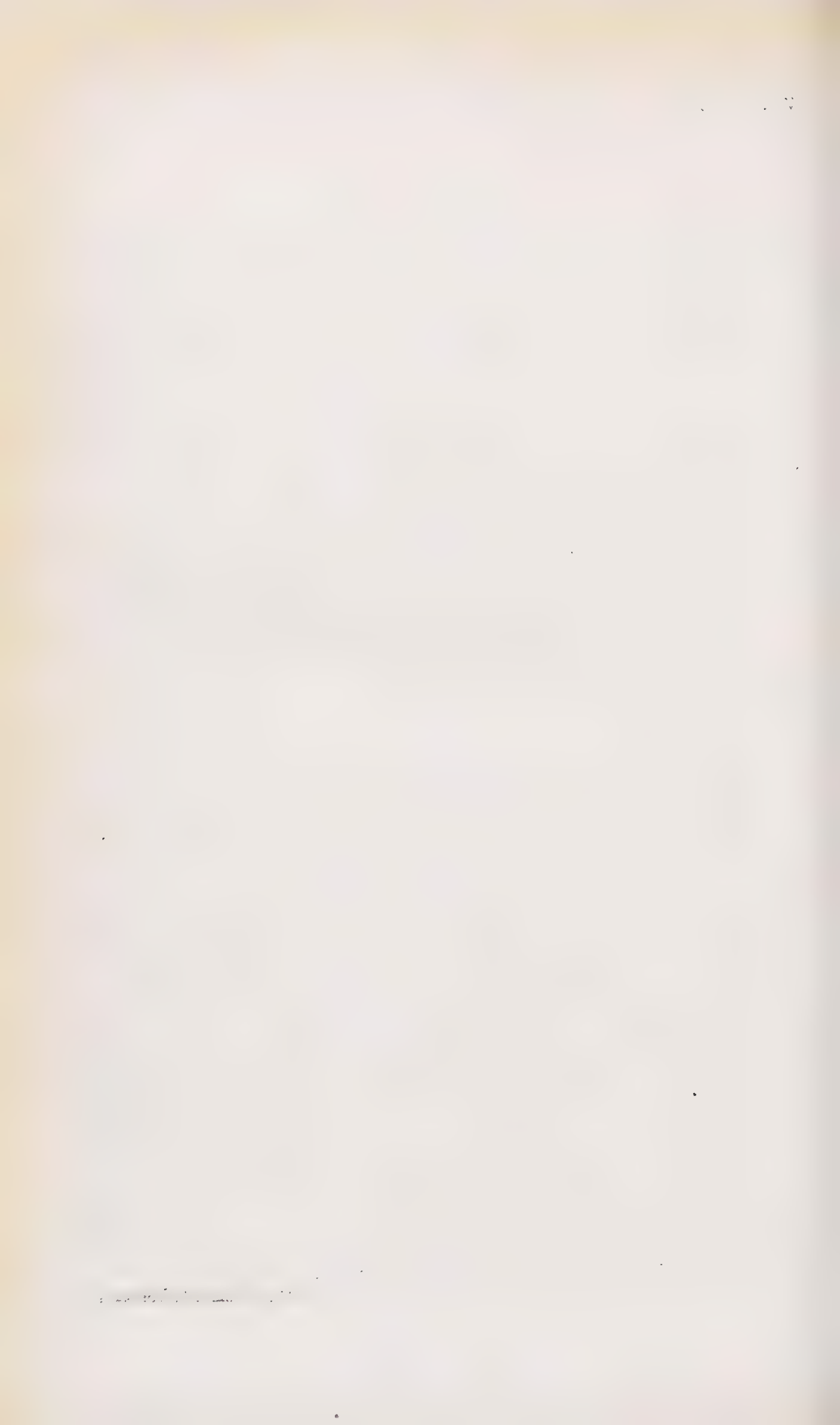

Plate XX.



CHAFFING COWPEA AND SORGHUM FOR SILAGE, BIGGENDEN STATE FARM.



Plate XXI.



GIANT RUSSIAN SUN FLOWERS, BIGGENDEN STATE FARM.

Plate XXII.



GENERAL VIEW OF THE BUILDINGS, BIGGENDEN STATE FARM.

Plate XXIII.



THE MANAGER'S RESIDENCE, BIGGENDEN STATE FARM.

clover is preceded by, say, wheat, and succeeded by potatoes, and if the ground has been occupied by it year after year, the land becomes what is known as "clover-sick," and the crop fails. Land kept continually under cereals becomes foul with weeds. In the case of small fruits, such as strawberries, too long a continuance of the crop on the same ground results in the land being filled with insects. Then, it should be considered that many plants feed only in the shallow surface soil, leaving stores of food deeper in the ground untouched. In order to utilise these plant-foods in the deeper sources, deeper feeding crops must be planted. Furthermore, there are crops which gain their entire sustenance from the soil, whilst others, like the legumes, draw a portion of their food, in the shape of nitrogen, from the air. The former impoverish the soil, the latter enrich it. Again, different crops draw unequally on the different food elements of the soil. A crop of beans or peas, for instance, draws heavily on the potash and lime in the soil, whilst a crop of wheat requires relatively small amounts of lime and potash, but large amounts of phosphoric acid. The same soil will, therefore, more easily produce a large crop of beans or peas, and a large crop of wheat following each other, than if two successive crops of beans or two successive crops of peas were grown.

For all these reasons—the maintenance of soil fertility, the renovation of impoverished soils, the production of large crops, the destruction of insect and weed pests, and the more economical distribution of labour throughout the year, and hence greater profits—a proper system of rotation is considered essential to continued success in modern farming. The rich farming lands of the older countries of Europe have been maintained in fertility for over a thousand years by the help of rotation, fallowing, and manuring.

There are certain systems of crop rotation generally designated by the number of crops entering into them. Thus, we have the three-course rotation, into which three different crops enter, such as wheat, followed by clover, and the latter succeeded by potatoes, after which wheat may again be grown. A four-course rotation may also be employed, although the three-course is most common wherever rotation is practised. A good four-course rotation consists of wheat or rye followed by clover, then maize, to be followed by oats. As soon as the oats are harvested, the ground should be got ready for the next crop on the rotation. A five-course rotation would consist of maize, potatoes, rye, and clover, or two or three years of lucerne. Where cotton is grown, a good rotation is maize the first year, oats and cow-peas the second, and cotton the third year.

It should be observed, however, that the rotation to be followed on different farms will necessarily vary with the nature of the soil, the seasons, the markets, &c., so that no one hard-and-fast system can be given which will serve as a guide to all farms. Some of the general principles that should guide in laying out a systematic rotation are as follows:—

1. Have at least one leguminous crop in the rotation.
2. Have at least one cultivated crop.
3. Rotate shallow-rooting crops with deep-rooting crops.
4. On leachy soils, have a growing crop on the land all the time.
5. Avoid bare summer fallowing.
6. Do not rotate small cereals with other small cereals.
7. Plan the rotation so as to have about the same amount of forage every year.
8. Keep stock on the farm.
9. Unless the farmyard manure thus made—unless it be thoroughly rotted—to the rank-growing crop in the rotation, such as maize.

FARMYARD MANURE.

The Board of Agriculture for Ireland has issued a useful leaflet on the production, management, and use of this manure. It is pointed out that— (1) It is produced in greater or less quantity on every holding. (2) By its use the manurial ingredients removed by crops consumed on the farm may be returned directly to the land. (3) It forms the basis of most systems of manuring. (4) It is suitable for application to practically every crop. (5) It has a most important influence on the physical condition of the soil.

Composition of Dung.—Dung is a complete manure—that is, it contains all the elements of plant food likely to be deficient in a soil—namely, nitrogen, phosphates, and potash. Although the quantities of these substances found in farmyard manure are small as compared with the amounts contained in artificial manures, this deficiency is in a large measure made good by the heavy dressings of dung it is customary to apply. Dung differs from artificial manures in several respects:—(1) The nitrogen, phosphates, and potash in it are present as much more complex compounds than they are in artificials, consequently the effect of a dressing of dung is spread over a longer period. (2) Farmyard manure has a beneficial influence on the physical condition of the soil. This effect, not obtained by the application of artificial manures, has an important bearing on soil fertility. Dressings of “long” dung render heavy retentive soils more friable and pervious to air and water, drainage is facilitated, and the land made easier to work. On light land, the application of well-rotted dung increases the retentive power of the soil for moisture and plant food. It is an important point in favour of dung that by its use the fertility of a soil can be maintained without the disadvantage of diminishing the stock of vegetable matter, such as occurs when artificials are used exclusively.

Liquid and Solid Manures Compared.—The liquid portion of farmyard manure is more valuable than the solid since it contains a greater proportion of nitrogen and potash, and, furthermore, the ingredients in it are in a more readily available and quicker acting form. Manure from which the liquid has been allowed to escape is much reduced in value, as most of the nitrogen and potash has been lost.

CONDITIONS AFFECTING THE QUALITY OF FARMYARD MANURE.

Farmyard manure varies considerably in quality owing to the widely differing circumstances under which it is produced. The chief conditions which affect its quality are worthy of consideration, and will be briefly discussed.

Kind of Food Used.—The greater portion of the manurial ingredients contained in foods are voided in the liquid and solid excrement. The average proportion of the total of each of the manurial ingredients consumed in food which pass into the manure are estimated as:—Nitrogen, about 75 per cent.; phosphates and potash, about 90 per cent. respectively. Since the greater part of the manurial constituents of dung are derived from food, it is evident that the quality of the feeding stuffs used very largely influences the quality of the manure. Foods such as cotton cake, linseed cake, &c., rich in fertilising ingredients, produce good dung.

Kind and Age of Animal.—Young animals making rapid growth and cows in milk extract greater quantities of the valuable ingredients from food than do fattening animals or working horses, and consequently the manure derived from young animals and cows in milk is poorer in quality than that voided by fattening cattle or working horses. It is estimated that a cow in full milk will extract from food four or five times as much nitrogen, three or four times the amount of phosphates, and about ten times as much potash as a fattening bullock fed on a similar ration.

Litter.—Litter influences the character of farmyard manure in several respects. In the first place, the physical effects of dung, to which reference has already been made, depend mainly on the kind and amount of litter mixed

through the manure and its state of decomposition at the time of application. Bulky litter which is but slightly rotted has the greatest physical effect on stiff soils, whilst the reverse holds good in the case of light soils. The materials used as litter, of which straw and peat moss are in most general use, contribute in a small degree only to the chemical composition of the manure, and if used much in excess of the quantity required for absorbing the liquid the resulting product will be more bulky but less concentrated than where the amount of litter is restricted.

Fresh and Rotted Manure.—Even under the most favourable conditions an appreciable loss of nitrogen occurs during the storing of dung, but provided the manure has been so treated as to reduce waste to a minimum, the smaller bulk of rotted manure will contain most of the nitrogen and practically the whole of the other manurial ingredients originally present in the fresh material; furthermore, the ingredients in manure rotted under such conditions will be more readily available as plant food.

Storage.—The method of storing farmyard manure has great influence on the final quality of the dung. No matter how rich the solid and liquid excrement may be in the first instance, a large proportion of the valuable ingredients of the manure are liable to be lost by subsequent bad management. Whatever may be the conditions under which dung is made and stored, care should be taken to prevent—

1. Loss of the liquid by drainage, for the reasons already indicated.
2. Over-heating, which drives off much of the nitrogen from the manure.

The following precautions for preventing loss from farmyard manure in either of the two ways mentioned are applicable to all conditions under which dung is produced.

The manure from different classes of stock varies considerably in character and quality. Thus, horse manure is rich, dry, and in bulk quick to ferment and overheat. On the other hand, manure from byres and piggeries is less concentrated, contains more moisture, is cold, and ferments slowly. A manure evenly rotted and of uniform composition is secured by mixing the dung from each class of stock together. It is a bad practice to keep each kind of manure in separate parts of the dung heap.

The manure should be spread over as little space as possible, kept well compressed and moderately moist. In covered yards, where cattle or pigs are kept on the manure, these conditions are easily attained. Open heaps, however, require more attention, and the manure should be compressed by wheeling each barrow load of dung over that already in the heap.

The bottom of the heap should be covered with a layer of some absorbent material such as bog mould, rough litter, &c., and a quantity of such substances also kept round the heap to retain the liquid; this material should be thrown up on the heap as it becomes saturated, and then replaced by a fresh supply.

Site of Manure Heap.—The manure heap must necessarily be situated convenient to the farm buildings, and consequently the choice of a site is often restricted. The most favourable situation is on level ground where there is small chance of water gaining access to the heap from springs, higher ground, or roofs of buildings, or of the liquid draining away from the manure.

Bottom of Manure Heap.—The bottom of the heap must be impervious to liquids. Concrete or hard bricks laid on edge make excellent floors, which in addition to being water-tight afford a hard surface for carting. A layer 8 to 12 in. thick of well-consolidated clay makes a cheap and in many respects a suitable floor. The bottom of the heap should have a distinct slope backwards, especially when there is a retaining wall at the back against which the manure can be compactly built.

AN AMERICAN'S ADDRESS TO FARMERS' BOYS.

It wasn't the schools and books and dairy papers that made those farmers in the cow census reports, who get less than a dollar's worth of milk for every dollar's worth of feed. It is not study, nor reading dairy papers and books, that makes such men. What does produce them? A lack of reading and study. They are not using their brains. They are not doing a thing to put sound knowledge in place of ignorance. They have never built up an ideal in their minds of a well-equipped, well-conducted dairy farm. They have never studied out the principles of dairy feeding as they are understood by the intelligent men in the business. When they were boys and young men, just as you are, they were not trained and encouraged by their fathers to make a deep, full study of this business called dairying. Their fathers never provided them with the means to improve their minds and take in useful knowledge, and so they came up with a low ideal of dairy work, of dairy farming, of breeding the dairy cow, and the care and feeding necessary to make her profitable.

This low standard of dairy farming is what is cursing them to-day. It is the thing that is holding them back. They don't see it, probably never will see it. "As the twig is bent so is the tree inclined." But you boys have the making of your future in your own hands.

Cultivate your minds by constant reading and thinking on farm questions. Don't follow in the starvation path these poor dairy farmers have travelled. Don't think that the less you read and study the more money you will make in farming, and the more you will be thought of among men. You are to be the farmers of the nation in the next twenty-five years. Remember that you cannot make a successful farmer with an ignorant mind.

If you have never been given a good education, don't be discouraged. You can educate yourselves by constant reading, thinking, and observation. Some of the brightest, finest farmers in the land to-day have arrived by that route. But be determined to build up a high standard of excellence in your minds concerning dairy farming. It is the character of your thinking that will make your labour valuable or not valuable to yourself and others.

Carry this thought with you always: Every day's work you do, every book and paper you read, every thought you think is making your education for you. It is these things that will lift you up or send you down. Be ambitious to make first-class farmers, the best in the land, of yourselves; to have the best-tilled fields, the cleanest stables, the best cows. It is a splendid ambition for any man to have. Then remember that the better farmer you are, the better citizen you will make. The bigger man you are inside your line fences, the greater you will be outside of them.

LETTUCE RUNNING TO SEED.

During the late hot weather it has been difficult to grow good cabbage-hearted lettuce, owing to its tendency in the height of summer to run to seed. A contemporary says that although this mishap cannot be wholly prevented, everyone may, by following the practice here given, bring about an essential improvement in his stock. The chief condition is to cultivate only such varieties as are found to succeed in the district. When the plant begins to form hearts, the finest of these should be marked throughout the bed, and as soon as these marked plants begin to shoot they should be pulled up for use, and this practice is to be persisted in till only so many plants remain in the bed as will suffice for affording a crop of seed. By this process of selection, carried on for some years, plants may be raised which will fully resist the effects of hot weather.

PREVENTING WASTE OF SILAGE.

Each year, as frequently as silos are filled, there is considerable waste, owing to the surface layer coming in contact with the air. The loss varies with the condition of the corn, and with the attention it has received after it is placed in the silo. In seasons of plenty it is a common practice to simply fill the silo and take chances on what would spoil. This is a very wasteful practice. It is possible to bring this waste down to a minimum by a little attention after the silo has been filled and thoroughly tramped.

Last year, owing to the scarcity of corn, we made an extra effort to preserve all that we had. As a result of which effort there was scarcely 2 in. of spoiled silage. After the silo was filled and thoroughly tramped we put a 2-in. layer of clover chaff on it. We then dampened this chaff with a barrel of water in which had been dissolved a 10-quart pail of salt. This brine proved to be the most effective preserver we had ever tried. On the surface, when we came to feed the silage, the 2-in. layer on top peeled off slick and clean, and left good silage immediately underneath. Try this scheme on your silo, and you will save much fodder that would otherwise be spoiled.—“Canadian Dairyman.”

PRACTICAL INSTRUCTION IN JUDGING STOCK.

During the last two years young men have been encouraged by the Queensland National Association to take a hand in judging stock at the annual show under the guidance of the regular judges. The experiment has proved very interesting and successful, and will go a long way towards rearing the judges of the future. From the “Mark Lane Express” we learn that the same course is being pursued by the committee of the Shaftesbury Farmers’ Club in England.

Theirs was one of the first clubs to introduce the system of judging stock in the show ring by young men prior to the animals coming before the appointed judge. So popular has this innovation become that several other societies have been and are taking up the same course of instruction; moreover, the officials of the County Council Education Committee are receiving the system favourably and encouragingly, looking upon it as a proper channel for imparting instruction in rural districts. It can be confidently said that in the near future this procedure will be greatly in vogue, as we know of no better method of training our young men in the methods of observation; and, in addition, the competition emulates them to take a keen interest in all classes of stock. It is hoped that arrangements may be made for the society’s judge or judges to give a demonstration, pointing out the essential and more important points of the animal.

The above-mentioned practical training is followed by a winter course of instruction in the scientific principles underlying the study and practice of agriculture.

COTTON-GROWING.

By DANIEL JONES.

GATHERING AND PREPARATION.

Much misapprehension exists relative to the method of picking cotton in our State.

Very much has been said of the great necessity for care in this process to avoid unduly gathering leaf and other *débris* along with the fibre; also on the need for drying and separating stained and immature fibre.

Too much emphasis has all along been laid on these precautions, resulting in valuable time being lost.

That ordinary care must be observed, in justice to the buyer, needs no reiteration, nevertheless the trader’s interests, along with the producer’s, are not advanced by methods which in themselves are not called for, and in the end serve to add largely to the cost of production.

For some years past it has been my object to lay before growers the importance of economically handling this crop so as better to meet local labour conditions, and generally expedite the picking operations. The cultural methods in vogue in Queensland, for the most part, call for little attention, the cotton crop requiring little, if any, more tillage or experience than what is demanded for ordinary field crops.

In the picking, however, we are lamentably lacking in that celerity common to the American cotton-grower. It will best serve my purpose to give, in as brief a manner as possible, the manner in which the farmer in the United State handles his great crop.

The American planter to-day, by reason of labour conditions, has little or no advantage over the Queensland grower. The day of abundance of negro field labour is now a matter of history; the negro, although once largely in evidence as a help in the cotton fields, has now, by reason of his advanced education, drifted into other, and, to him, more congenial fields of activity than that of the ordinary farm hand.

So it happens that a large percentage of American farms have no coloured or cheap labour whatever employed. Thus Queensland farmers are under no disability in the matter of low-priced labour. The secret of American superiority lies in the fact that their simple and methodical handling of the crop gives them a very material advantage.

In Queensland a picker, if, at the end of a day's toil he has gathered 100 lb. of fibre in the seed, it is regarded as a good evidence of brisk effort, while an increase of 20 to 30 lb. constitutes a record, working on Upland varieties. With the American this quantity represents a very poor day's work, three and even four times this amount being frequently gathered for periods of time.

The Washington Department of Agriculture makes the official statement "that first-class pickers can pick, by hand, an average of 500 to 600 lb. of seed cotton per day, and as much as 800 lb. occasionally. A white hand was timed in 1894, and he picked 60 lb. in an hour, or 1 lb. per minute." This, of course, is not possible unless there is a good blow of cotton out, and in the process a more than ordinary amount of leaf-trash is collected with the fibre.

As evidence in substantiation of the claim here made on behalf of the American picker, I may give my personal experience at Capella, in Central Queensland, in June last, on the farm of Mr. Willis Hargrove, an American grower recently settled in that locality, and who is chiefly engaged in this vocation, beginning in a small way with a few acres. Mr. Hargrove then, had employed a young American, a Mr. Rowan, who has since gone into cotton-growing on his own account, and, at the present time, has 30 acres looking well and nearly ready for harvesting, in the same district. This person elected to prove that American claims were genuine, and, in my presence, in two hours he gathered 58 lb. cotton, 27 lb. in the first hour, and 31 in the second, which, at the price of $\frac{1}{2}$ d. per lb. for picking (the rate allowed) shows his earnings to be a fraction under 1s. 3d. per hour. It may be said this was an exceptional spurt, but as it was done in but a half-crop of cotton, it is easy to realise that an average of 250 to 300 lb. a day would be no extraordinary result for an active experienced picker.

In handling such cotton as Sea Island, Egyptian, Mascotte, or Caravonica varieties, equally good results will not be attained, by reason of the character of the cotton bolls, which are not free in parting with the fibre, and not as large in pod.

The person here referred to claimed to have picked, in the States, 500 lb. a day on many occasions. To enable this to be done, very expert handling must be acquired, especially the ability to gather equally as well with the left as with the right hand, using both simultaneously. This training is acquired by degrees, and it is always impressed on the young picker that

both hands must be trained to acquire the ability to pull the fibre with equal facility. This once mastered, solves the problem of economically and profitably handling a large cotton crop, without which the Americans would often lose a large portion of their annual 14,000,000-bale harvest, and ensures for the pickers, even at a much lower scale of payment than our growers are satisfied to pay, a fair remuneration for his service.

To enable the picker to best carry on his work without impediment, the Americans use a different picking bag to ours, being in every way much easier on the pickers. It is made of strong calico, and is about 7 or 8 ft. long, with shoulder straps made so as to allow the bag to swing on the left side, and, for the most part, trailing on the ground behind the picker. This bag is thus constructed to permit the free use of both hands, and avoid loading the picker with the weight of fibre gathered which lies in the bag trailing behind him. This bag when full is emptied on a sheet placed in a convenient position in the field, and is usually all the drying the cotton gets. Of course, no cotton is gathered under wet weather conditions. Should rain take place before the cotton is placed under cover, then a further drying process is imperative.

It must be expected that cotton so rapidly picked is not as free from leaf and dirt as in the case of the slower process; nevertheless, the American buyer is content to have his article in this form, and no diminution of value ensues as the result of a little foreign matter in the fibre, which is practically unavoidable under the circumstances.

In Queensland we have erred too much in our method of picking and drying of this crop. My remarks here refer only to the Upland and low-priced fibres. Such high-quality cotton as Sea Island must have very much more care taken in its picking and preparation for market. Upland cotton then, is easy to gather, particularly if the pickers do not enter the field to look for cotton. Too often our growers start their hands into the field, and, after rambling about all over the rows, they have little to show for their time. This practice is often indulged in by those unfamiliar with the pursuit, who have lent the ear to needless warnings of danger from over-exposure to weather, wet or dry.

My local experience is that the weather rarely injures a cotton crop when fit for gathering. Cotton, if well opened, will stand heavy rain with little injury. It is when the pods are partly opened, and lodgement is found for the wet, that the greater damage is inflicted. However, this is a misfortune not often experienced here, the reverse being too often the case, since, the absence of rain is a more dreaded feature of agrarian interests than surplus moisture, which may, in any serious degree, menace a cotton crop.

Stained cotton also is sometimes referred to as an undesirable feature of the crop, and too much has been said about the liability of the Queensland crop to this risk. Rarely, if ever, does the cotton come to hand in commercial quantities where this objection can be raised. Cotton which is stained is seldom gathered, nor does it pay the picker to trouble with any cotton but the clean, ripe, and well-opened. Stained cotton, unless the discolouration be due to the depredations of beetles, is rarely seen in Queensland, is usually due to weather or boll worm attack, and, so far, in very limited quantity, hence it is never considered profitable to bother with any fibre but that which is of first quality. This simplifies and accelerates very much the operation of gathering. Last season's cotton was gathered in satisfactory condition after three months' exposure to the weather, no reduction in value being enforced on the grower. This disproves the idea expressed by those unacquainted with cotton that it is too tender in its nature to stand long exposure without detriment to its value. Here, with our dry warm Summer and Autumn weather, when the cotton opens out, the conditions for successful harvesting are ideal ones, no other cotton country having any conditions superior to ours in this respect, save perhaps Egypt, where rain rarely falls, and the crops cannot be produced otherwise than by an expensive system of irrigation.

In pointing out, as here stated, the most economical methods of picking cotton, it will, I trust, be understood that in no sense is it laid down that the crop can just be hustled in without any care or supervision. It is not judicious nor safe to neglect ordinary precautions in preparing the fibre in good order and condition, for this, in justice to the buyers, must be attended to. Hitherto we have undoubtedly erred on the other side, and in our extreme anxiety to have our article in top condition, we have materially and unnecessarily increased the cost of production. The American has no such scruples, and thus is enabled to handle his 200 to 300 lb. of cotton per hand with ease. Again, his field operations are also much less extended than ours, whereby he saves labour at points where our methods are superfluous.

Briefly stated, in the United States, the planter sends his hands into the field when the blow is good—no looking for fibre. The pickers gather with their usual speed, the picking bag, as heretofore described, is emptied on to a large sheet, which is about all the drying the cotton receives. This remains on the sheet until noon or till the day's work is over. The four corners of the sheet are then drawn together, and the cotton therein carried to the wagon located in the field ready for it. Often the fibre is carried direct from the pickers' bags to the wagon. It is here weighed and loaded. When the wagon is transferred and filled, the mules are hitched in, and the team pulls the vehicle to the ginnery, located in the most central position convenient to the general body of planters.

On arrival at the ginnery the load is placed on a weighbridge and recorded.

Subsequently a suction tube, operated by a fan, is lowered into the wagon and the contents are rapidly drawn into the battery of gins operating in the building. The lint and seed are separated, the seed dropping into sacks for transport, the lint falling into the hydraulic presses. Thus, scarcely a hand has touched the fibre since the picker placed the article in his bag.

This is how the up-to-date Yankee now handles his huge cotton crop and makes a living under much greater difficulties than the Queensland grower has to contend against.

American land is dearer than ours; it invariably must be fertilised with costly manures; the yield per acre does not, on the average, come up to the Queensland yield; insect troubles are greater; the quality of lint is not so good as ours.

This is admitted by the British Cotton Growers' Association, who have repeatedly stated our fibre to be worth 1d. per lb. over average American.

If our motto now is as it once was: "Advance Australia," it then becomes the duty of all to recognise the potentialities of this vocation. So far as our limited plantings have shown during the past few years, cotton has given better returns to farmers than most farm crops.

Economy in handling as here outlined will do much to popularise this pursuit if the country is to become an agricultural State.

The outlook in this direction is not too promising; with the heavy decline reported in agriculture last year, totalling, as per report of Department of Agriculture, 30,000 acres, it looks as though this State is to be noted for little else than its mineral, grazing, and dairying activities. These, in themselves, are very important, but are not the interests which best promote close and permanent settlement, just as important? A cotton planter with little capital, under ordinary conditions, can make sure of a good living on 30 acres of crop, usually returning from £6 to £9 or over per acre. He gets from 1 acre quite as much as a dairyman does from one cow, with much less risk and attention and deprivation of home comforts. One point I wish to emphasise is this—that the so-much-talked-of interference with the children's education as the sequence of cotton cultivation stands without point. Most farm pursuits engage the little ones, but I know none, save sugar, which offers the same opportunity of satisfying the adult in point of remuneration as this crop does.

If the American can gather—and he undoubtedly does gather—the amounts credited to him, we need no juvenile or cheap labour. An active adult trained to the work, which is quickly acquired, earning his 6s. or 7s. a day in a light, healthy, open-air pursuit, should have no ambition to seek the unhealthy, cramped occupations of the factory.

As a change of vocation for our male and female factory operatives, this work should be very popular, for not only would the earning be superior to the city vocation, but the cost of living would be much cheaper, and the work calling for little skill or strength, would be within reach of many who, under present conditions, are either or nearly on the verge of becoming unemployable.

The season's crop is now nearly ready in some districts for gathering, and it will be well for growers to study the system outlined for the cheaper handling of the crop. Farmers in dry weather can safely transfer such cotton as is free from wet or dew and fully ripe, direct from the picking bags to the bale, which will be economy in handling and economy of space and room.

A NEW DOUBLE-HEADED WHEAT.

A South Australian paper reports that an engine-driver, Mr. J. J. O'Shea, at Eudunda, last year noticed amongst a wheat crop a plant bearing two heads on each stalk. Anticipating a new wheat, Mr. O'Shea carefully collected every grain, with a view of testing his find. The grain thus got weighed $5\frac{1}{4}$ oz. Mr. O'Shea, so as to make a thorough test of the wheat, put the experiment in the hands of Messrs. Dermody Bros. The grain was sown between a drilled strip of Marshall's No. 3 and Bluey, no grain being sown in the centre strip by drill. The new wheat was hand sown afterwards, about the same distance apart as that sown by the drill.

The result eclipsed all expectations. On an average the Marshall's and Bluey varieties produced eight stalks for every grain sown, and the new variety had sixteen to every grain sown; while, more remarkable still, the plant which last year produced two heads, this year had in some instances as many as seven heads. These heads are very distinct, and easily counted. The centre head is in appearance like any bearded variety, while the additional heads grow out of two sides of the centre head, the largest being towards the butt of the stem, gradually diminishing in size towards the end of the head. The actual amount of wheat gathered from the $5\frac{1}{4}$ oz. sown is $59\frac{1}{2}$ lb. This works out at 90 bushels per acre, taking the quantity sown per acre as being about half a bushel, on which basis it was sown. Mr. O'Shea showed his wheat to several of the leading wheat-buyers and farmers of the district, but the variety was new to all of them. A difference of opinion exists as to the original formation of the variety. Some think that it was brought here in imported manures, as it was not unlike a variety of Egyptian wheat, whilst others hold the opinion that it is a new wheat formed through natural hybridisation. In order to prove the value of his find, Mr. O'Shea is keeping the whole of his gathered grain, proposing this year to sow the quantity on 2 acres of land.

ANOTHER NEW CLOVER.

A new forage crop, the Clover Moellier, is described in the "Journal of the Victorian Department of Agriculture." It grows 4 ft. to 5 ft. in height, and yields a great quantity of succulent foliage, which may be cut off five times in a season, or, as the stems are fleshy, the whole plants may be chaffed for animals. All kinds of stock eat it eagerly, and it is said to be highly nutritious. It withstands drought and frost alike. In a trial of the plant carried out by the official Dairy Supervisor, the weight of the first cutting of leaves was estimated at 4 tons per acre. The labour of cutting off the leaves and carrying them off the cropped land must be a great objection, except perhaps to occupiers of small holdings.

Dairying.

THE DAIRY HERD, QUEENSLAND AGRICULTURAL COLLEGE,
GATTON.

RECORD OF COWS FOR MONTH OF JANUARY, 1909.

| Number. | Cow's Name. | Breed. | Date of Calving. | Total Milk. | Average Test, Per cent. | Commercial Butter. | Remarks. |
|---------|-------------------|--------------------|------------------|-------------|-------------------------|--------------------|-------------|
| | | | | Lb. | | Lb. | |
| 1 | Dot ... | Shorthorn ... | 12 Nov. 1908 | 1,023 | 4.0 | 45.76 | |
| 2 | Gem ... | Grade Shorthorn | 13 Dec. " | 868 | 4.2 | 40.83 | |
| 3 | Whitefoot ... | Holstein-Devon | 20 Oct. " | 899 | 4.0 | 40.18 | |
| 4 | No. 112 ... | Grade Guernsey | 24 Nov. " | 899 | 4.0 | 40.18 | |
| 5 | Orange ... | Guernsey ... | 23 Oct. " | 651 | 5.1 | 39.32 | |
| 6 | Bee ... | Jersey ... | 9 Dec. " | 589 | 5.5 | 36.28 | |
| 7 | Graceful ... | Grade Shorthorn | 10 Dec. " | 620 | 5.0 | 35.00 | |
| 8 | Conceit ... | Ayrshire ... | 22 Dec. " | 826 | 3.9 | 34.95 | |
| 9 | Careless ... | Jersey ... | 7 Dec. " | 775 | 4.0 | 34.63 | |
| 10 | Dora ... | Shorthorn ... | 18 Nov. " | 744 | 4.0 | 33.24 | |
| 11 | Peewee ... | Holstein-Sh'rth'rn | 20 May " | 696 | 4.1 | 31.91 | |
| 12 | Laura ... | Ayrshire ... | 16 Nov. " | 790 | 3.5 | 30.66 | |
| 13 | Poppy ... | Grade Guernsey | 10 Jan., 1909 | 868 | 3.2 | 30.62 | |
| 14 | Lowla ... | Ayrshire ... | 8 Dec., 1908 | 773 | 3.3 | 28.17 | |
| 15 | Len ... | " | 6 May " | 682 | 3.7 | 28.07 | |
| 16 | Daisy ... | Holstein ... | 24 Oct. " | 813 | 3.1 | 27.73 | |
| 17 | Comet ... | Grade Holstein ... | 20 Nov. " | 690 | 3.6 | 27.60 | |
| 18 | No. 1 ... | Shorthorn ... | 1 Nov. " | 744 | 3.3 | 27.11 | |
| 19 | Sue ... | Grade Holstein .. | 25 May " | 604 | 4.0 | 26.99 | |
| 20 | Nita ... | Shorthorn ... | 23 Nov. " | 713 | 3.4 | 26.83 | First calf] |
| 21 | Dewdrop ... | Holstein .. | 11 Nov. " | 713 | 3.4 | 26.83 | |
| 22 | Night ... | Grade Holstein... | 5 Oct. " | 713 | 3.4 | 26.83 | |
| 23 | Mona ... | " | 20 Oct., 1907 | 620 | 3.8 | 26.25 | |
| 24 | Wonder ... | " Shorthorn | 2 Dec., 1908? | 705 | 3.3 | 25.80 | |
| 25 | Nancy .. | " | 7 May " | 565 | 4.0 | 25.25 | First calf |
| 26 | Ethel ... | " Holstein... | 3 Sept. " | 631 | 3.6 | 25.24 | |
| 27 | Lady Loch | Ayrshire ... | 24 June " | 495 | 4.5 | 25.03 | First calf |
| 28 | Remit ... | Holstein ... | 5 Aug. " | 620 | 3.5 | 24.06 | |
| 29 | Carrie ... | Jersey ... | 16 Jan. " | 468 | 4.5 | 23.66 | |
| 30 | Cocoa ... | " | 20 Nov., 1907 | 519 | 4.0 | 23.19 | |
| 31 | Lalla ... | Grade Holstein... | 28 July, 1908 | 505 | 4.0 | 22.57 | First calf |
| 32 | Eve ... | Jersey ... | 16 Oct. " | 527 | 3.8 | 22.30 | |
| 33 | Burton's
Fancy | Shorthorn ... | 7 Sept. " | 400 | 4.6 | 20.70 | First calf |
| 34 | Grace ... | " | 30 May " | 579 | 3.2 | 20.42 | |
| 35 | Stranger ... | " | " | 508 | 3.5 | 19.72 | |
| 36 | No. 223 ... | Ayrshire... | 1 Dec., 1908 | 540 | 3.3 | 19.68 | First calf |

Cows fed on natural grasses.

CHOOSING A DAIRY BULL.

That the bull is at least half or three parts of the future herd is an axiom which is unanswerable, and it is not only necessary to use a thoroughbred bull but to know his ancestors for three or four, or even five, generations past. It is not sufficient to know what his dam is. Succeeding generations of his dam may show improvement, but not from her own qualities alone. It comes from her inheritance, and that inheritance will very often in the bull come from three or four generations back. As to the breed of bull, this depends very much on the character of the country. For instance, it is no use putting Jerseys on swampy country, and at the same time it is of no use putting large-bodied shorthorns on to pasturages where there is not enough grass to

feed them, for when you have large-framed beasts you must have plenty of herbage. Each dairyman must decide on the class of cattle best suited to his own circumstances. A common mistake with dairymen is to change their breed. If the land is most suitable for Jerseys, get a bull of the best Jersey strain. On the other hand, if the land is low and swampy, Ayrshires will generally be found the most useful, and whatever breed is chosen stick to it, unless, of course, the results turn out unsatisfactory. There are many who prefer the milking shorthorn, and where there is plenty of rich pasturage this breed may pay best, as the steers can be fattened off and add greatly to the profit of the herd. The dairyman, however, with a small herd and a limited area of land will do well to stick to one of the two "dairy breeds," and so, whatever may be the breed of his cows, he may by using pure-bred bulls, and always of the same strain, appreciably improve his herd, and with the continued use of pure-bred bulls on the heifers thus bred it will certainly be astonishing if a first-rate dairy herd is not collected in the course of a few years. There is another phase of the subject which is worthy of attention, and that is in-breeding. This practice has been too long and persistently tried by the best breeders the world ever saw to need much argument, as all the best cattle in England and America are a result of this way of breeding to intensify and perpetuate the desired qualities in the offspring. It is well within the reach of every dairyman to grow and develop choice grades that for all practical purposes would be as good as the thoroughbred animal from which the cross was instituted, and maintain a high standard in his dairy by the careful selecting and mating of his breeding animals. There are two axioms that should always be remembered: Cull out all the indifferent milkers, of whatever breed they may be, and keep for breeding only those heifers whose dams were remarkable for their milk and cream production.

CURING HAMS AND BACON.

Before being killed, a pig should have nothing to eat for at least twelve hours preceding the slaughter. By whatever means the animal's death is accomplished, every endeavour must be made to get the last drop of blood out of the body, otherwise the flesh will not cure well. As soon as this is done, the carcass should be plunged into almost boiling water. The proper temperature is very important. If either too hot or too cold, the hair will not come freely off. A good old-fashioned plan to try the temperature is to let a few drops of pig's blood fall on the water. If it spreads all over the surface, the temperature is right. Leave the pig in the water till the hair comes freely off. The next thing is to hoist the carcass out of the water. Hang it up and scrape it vigorously with some sort of blunt scraper; the lid of a billy is as good as anything else. When the hair is removed, dry the carcass well. Next, remove the intestines, and wipe the inside of the body dry. Let the pig hang in a cool place for twenty-four hours. Then cut it up into hams, hands, spare-ribs, loins, and belly pieces. The spare-ribs and loins are usually roasted fresh. The other parts are rubbed over with coarse salt and a little saltpetre, and laid on a table, flesh uppermost, so as to drain off any blood.

Where a side is to be dry-cured whole, after removing the joint oil and washing the cavity freely with salt and water, the flesh part of the side should be sprinkled freely with equal parts of powdered saltpetre and boric acid, to retain the colour. After twenty-four hours wash this mixture off. Then dry-salt with the following:—50 lb. best fine dairy salt, 5 lb. of brown sugar, 5 lb. of powdered saltpetre, 5 lb. of boric acid.

These should be well mixed and passed through a fine sieve. Rub the flesh freely every morning with this mixture for fourteen days. Each day

drain off all accumulated fluids. More care should be directed to rubbing the first two days, after which it may be conducted more lightly. The sides are laid one on each other, and reversed every day.

When the curing is completed, wash off the salt, &c., with warm water, and hang the side up to dry in a well-ventilated room. With favourable weather this will take from four to six days.

The bacon is then hung in the smoke-house. The fire-place is outside the smoke-house, from which a flue communicates with the centre of the floor, to reduce the temperature of the smoke as much as possible before reaching the bacon. It is a distinct advantage to smoke in a cool state. Native apple-tree and hardwood sawdust, or damp maize cobs, are useful to smoke with, and will improve the flavour. The smoking will take from four to five days. Judgment is needed to determine when the flavour is sufficiently developed.

THE BEST PORK-PRODUCING RATION.

Wiltshire is an English county famous for its pigs and pig products. Determined to arrive at finality in the matter of the most profitable feed for pigs, the Wiltshire County Council spent £250 on making exhaustive experiments, and at last came to the conclusion that the best pork-producing ration in the world is:—"One gallon of skim milk or butter-milk per day, 3 lb. of potatoes, and barley meal to make up the day's ration."

On this feed, says "Australian Field," pigs, weighing from 80 to 100 lb. each, made a weekly gain of 15 lb. Compared with a feeding ration of all barley meal, the feed gave a result of as 1,000 to 500—that is to say, it was twice as good. The potatoes should always be boiled, and no rotten ones should on any account be fed to pigs. Take a little trouble, and cut and wash them. Make the milk go as far as possible, and remember that if you are giving your pigs 2 gallons of milk a day, you are wasting 1 gallon.

A NEW CASEIN TEST.

When visiting the Wisconsin Experiment Station, the Dairy Commissioner, Mr. D. Cuddie, met the two scientists attached to this station—Professor Babcock (the inventor of the great butter-fat test which bears his name) and Dr. Hart—and was privileged in being given a demonstration by these investigators of a test designed by the latter for ascertaining the amount of casein in milk. Mr. Cuddie was so struck by the value of the next test—its efficacy and simplicity—that he has secured one for the Department. The tester is constructed very much after the style of Dr. Babcock's machine, with the essential difference that the test bottles are reversed, the measuring neck being thrown outwards, for the reason that the casein being the heavier material in the milk is driven away from the centre by the centrifugal force. The materials used to separate the casein are acetic acid and chloroform. The test can be made by a boy. The extent of its utility has yet to be demonstrated, but it will probably prove of considerable value in connection with cheesemaking. Mr. Cuddie is now conducting an experiment to discover the casein contents of milks of varying butter-fat percentages, and thus provide a guide as to their relative value from a cheese-making point of view.—N.Z. "Town and Country Life."

The Horse.

SOUND STALLIONS.

Every horse-breeder will agree that it is desirable to breed from sound horses and mares. There are, however, unfortunately many so-called breeders to whom cheapness is everything, and the result is, that numbers of young stock are the progeny of unsound or weedy stallions, whose service can be obtained for one-half, or even for one-fifth, of the fee charged by the owner of a first-class, thoroughly sound sire. Why people are so blind to their own interests is inconceivable. A low-class colt or filly is more troublesome, and costs more to feed, than a really well-bred one, and the price obtained for either as a two or three year old is small in comparison with what would be paid for the better-class animal. It is truly a penny-wise, pound foolish course of proceeding.

The "American Cultivator," referring to the question, states:—The stallion should be pure-bred, recorded, certified to as regard breeding, and an excellent individual. It is of as great importance that he should be free from all forms of unsoundness or disease that are hereditary, transmissible, or communicable to offspring. It is equally as important and necessary that the mares bred to him should be sound in the same way, and not until both mares and stallions used for breeding purposes are free from unsoundness, such as we have indicated, can we confidently hope to raise the average excellence of our horse product to the high plane possible as the result of intelligent breeding and development. Many imported and home-bred stallions are unsound, and transmit to their progeny the predisposition to like unsoundness. This equally is true of the mares used for breeding purposes throughout the State, for many farmers have fallen into the grievous error of considering any broken-down, halt, maimed, blind, or otherwise unsound mare fit for breeding purposes, when no longer able to work in harness. Every breeder should have a clear understanding of the diseases and unsoundnesses that may correctly be deemed hereditary and transmissible, either in fact or as a predisposition. On general principles it may be confidently stated that blemishes and deformities due to accidental causes are not hereditary or transmissible, and do not, therefore, render the individual animal unfit for breeding purposes. In this category may be set down unsightly scars from barb-wire injuries, or similar accidental causes; blindness, due to accident; lameness, due to injury; united fractures, not implicating the pelvis causes, apart from disease, unfitting animals for labour. The greatest possible care must, however, be exercised in deciding these matters; and, where possible, it is much the better policy to select for breeding purposes animals in the best of health and free from every form of blemish or unsoundness, on the principle that breeding material should be of the best procurable character and quality.

BROKEN BONES OF HORSES.

A popular notion exists that broken bones in the horse do not mend readily (writes New Zealand "Town and Country Life"), and that a fractured leg-bone constitutes a hopeless case, consequently the animal is consigned to the knacker or destroyed. Hores are often consigned to destruction for a broken leg—no matter even if it be a simple fracture which could easily be placed in a state for speedy repair, and no matter how valuable the animals

may be—because of this often mistaken notion that attempts at a cure are futile. It should be known that the bones of a horse unite, when fractured, more readily than do those of a man, and that some skill and a little care and patience will in many cases be rewarded with an excellent recovery, and the animals made as useful as ever. Even in bad fractures of certain bones of the limbs recovery will take place, and, though the horse may not be absolutely free from lameness afterwards, yet in the case of a valuable stallion or mare this is not of so much importance, as the animal can be well utilised for breeding purposes. The indiscriminate use of the pole-axe or the bullet is a most regrettable blunder in many cases.

Statistics.

COMMONWEALTH METEOROLOGY. RAINFALL OF QUEENSLAND.

TABLE SHOWING THE TOTAL RAINFALL FOR EACH MONTH OF THE YEAR IN THE AGRICULTURAL DISTRICTS OF QUEENSLAND.

| STATIONS. | 1908. | | | | | | | | | | | | 1909. |
|------------------------------------|-------|-------|-------|--------|-------|-------|-------|------|-------|------|------|------|-------|
| | Jan. | Feb. | Mar. | April. | May. | June. | July. | Aug. | Sept. | Oct. | Nov. | Dec. | Jan. |
| <i>North.</i> | | | | | | | | | | | | | |
| Bowen | 10.14 | 5.63 | 9.46 | 3.73 | 0.99 | 0.45 | 0.88 | 0.51 | 0.96 | 2.47 | 0.42 | 0.42 | 15.48 |
| Cairns | 27.02 | 8.03 | 20.60 | 5.99 | 3.05 | 0.59 | 3.70 | 2.12 | 0.74 | 3.07 | 1.60 | 1.41 | 32.05 |
| Geraldton | 44.39 | 13.27 | 39.00 | 14.23 | 18.52 | 2.64 | 8.11 | 3.66 | 2.81 | 6.93 | 3.80 | 1.69 | 47.92 |
| Gindie State Farm | 0.20 | 7.17 | 6.25 | 0.02 | 0.112 | ... | 0.40 | 1.27 | ... | ... | ... | ... | ... |
| Herberton | 9.29 | 5.02 | 8.92 | 1.10 | 0.38 | 0.31 | 2.36 | Nil | 0.51 | 1.27 | 0.61 | 0.78 | 12.41 |
| Hughendes | 0.93 | 5.18 | 6.91 | 0.30 | Nil | 0.05 | 0.68 | Nil | Nil | 1.67 | 1.94 | 1.05 | 7.55 |
| Kamerunga State Nurs. | ... | 7.47 | 25.75 | 1.60 | 3.363 | 0.76 | 4.85 | 1.58 | ... | 3.64 | 1.69 | ... | ... |
| Mackay | 9.23 | 3.83 | 17.43 | 14.82 | 3.25 | 1.29 | 1.65 | 0.71 | 2.27 | 1.80 | 2.57 | 0.2 | 15.00 |
| Rockhampton | 3.84 | 9.64 | 9.77 | 2.62 | 0.85 | 0.10 | 1.08 | 0.84 | 0.20 | 2.14 | 2.47 | 1.37 | 9.01 |
| Townsville | 12.21 | 6.69 | 9.03 | 0.38 | 2.22 | Nil | 1.70 | 0.27 | 0.28 | 1.58 | 1.26 | 0.7 | 6.94 |
| <i>South.</i> | | | | | | | | | | | | | |
| Biggenden State Farm | 2.37 | 9.82 | 9.81 | 2.97 | 0.74 | 0.43 | 0.49 | 2.33 | 1.39 | 1.80 | 2.12 | 3.66 | 7.37 |
| Brisbane | 2.80 | 8.43 | 18.19 | 2.45 | 2.40 | 0.17 | 0.77 | 2.83 | 0.67 | 1.77 | 2.25 | 1.28 | 1.99 |
| Bundaberg | 4.77 | 2.82 | 7.35 | 4.13 | 0.67 | 0.39 | 0.75 | 1.56 | 1.10 | 2.39 | 0.73 | 3.34 | 6.52 |
| Dalby | 0.17 | 4.88 | 7.61 | 0.11 | 0.37 | 0.63 | 0.14 | 1.80 | 1.13 | 2.55 | 3.65 | 1.56 | 1.46 |
| Esk | 2.61 | 10.06 | 17.04 | 2.83 | 1.07 | 0.23 | 0.46 | 2.75 | 2.16 | 1.29 | 5.99 | 3.62 | 2.64 |
| Gatton Agric. College ^s | ... | 3.38 | 10.74 | ... | 0.10 | 0.16 | 0.6 | 2.71 | 1.84 | 1.93 | 5.71 | 1.29 | 1.94 |
| Gympie | 6.28 | 11.77 | 8.08 | 1.87 | 2.00 | 0.38 | 1.16 | 2.87 | 1.37 | 2.49 | 2.58 | 3.97 | 3.86 |
| Ipswich | 1.32 | 6.63 | 13.77 | 2.71 | 1.14 | 0.12 | 0.47 | 3.23 | 1.19 | 1.48 | 5.09 | 1.05 | 1.37 |
| Maryborough | 5.62 | 8.07 | 11.40 | 2.52 | 1.05 | 0.46 | 0.81 | 1.98 | 1.05 | 1.84 | 1.92 | 1.64 | 8.36 |
| Roma | 0.04 | 6.38 | 2.51 | 0.22 | Nil | 0.55 | 0.63 | 1.38 | 1.12 | 2.15 | 2.79 | 1.68 | 5.19 |
| Roma State Farm | ... | ... | ... | ... | ... | ... | 1.27 | 0.73 | ... | ... | ... | ... | ... |
| Tewantin | 10.42 | 12.47 | 14.39 | 7.59 | 8.66 | 0.75 | 1.97 | 2.70 | 2.18 | 2.30 | 7.50 | 4.12 | 6.44 |
| Warwick | 0.76 | 4.52 | 6.65 | 1.40 | 0.15 | 0.80 | 1.24 | 2.69 | 1.96 | 0.96 | 5.28 | 2.02 | 0.87 |
| Westbrook State Farm | 0.43 | 8.03 | 1.41 | 1.40 | 00.5 | ... | 0.49 | 1.97 | ... | ... | 2.05 | ... | ... |
| Yandina | 8.37 | 14.47 | 16.62 | 5.45 | 4.59 | 0.58 | 2.64 | 2.18 | 1.50 | 3.10 | 6.03 | 2.75 | 6.69 |

NOTE.—The rainfall data in this table are compiled from telegraphic reports, and must be considered as approximate only.

GEORGE G. BOND,
Divisional Officer

Poultry.

DISEASES OF POULTRY.

Although poultry in Queensland are not very subject to diseases, mainly owing to the genial climate rather than to the care of their owners, still an epidemic disease will sometimes pass like a wave over a whole district, leaving devastated poultry-yards in its wake. In such cases as this there is nothing to be done but to bury the departed birds. There are, however, isolated cases of disease, which, if taken in time, can usually be cured; and it is, therefore, advisable to know the symptoms of such diseases, as well as the best means for prevention and cure. Such are:—

ROUP.—This disease is not an uncommon one, but if taken in hand at once is comparatively easy to cure. A bird suffering from this complaint has a discharge from the nostrils and eyes, which smells most offensively. There is also a disinclination to roost, and the patient huddles itself up in a corner, both at night and during the day. When roup is first suspected, bathe the nostrils and eyes with chlorinated soda and water (one part of former to two of latter). If the discharge is very bad bathe two or three times during the day, the patient being housed in a coop, free from draughts, with a layer of clean hay or straw for bedding. Feed on wheat or good clean bran and pollard, mash with a little cayenne pepper, or chillies cut fine. When signs of improvement are manifest, add a little sulphur to the soft food two or three times a week. As in the case of cholera, everything that the birds have access to should be thoroughly cleansed and disinfected, as roup is highly contagious. There are several "roup cures" on the market, and these can be used with advantage, but in the case of them not being procurable, if the foregoing instructions are carried out the chances are all in favour of the birds' recovery.

CATARRH is a disease very similar in its symptoms to roup, but there is usually a distinct coughing and wheezing as well. Use the same treatment as for roup.

CROP-BOUND.—This can hardly be described as a disease, and is caused principally by over-feeding with grain, which swells with the moisture in the crop and blocks the entrance of the pipe leading to the gizzard. Long grass also is a frequent cause of a bound crop, through its getting jammed in the outlet. The mode of procedure to effect a cure is to give the bird an emetic of a strong mixture of epsom salts and tepid water. Then hold by the legs with head down and gently knead and rub the crop with the hand. It may take a long time to empty the crop by this means; but, if not successful, then the crop must be opened and cleaned out. This is rather a delicate operation, but if great care is exercised it should not be a failure. Pluck the feathers from the breast immediately over the swelled crop, and make an incision 1 in. or 2 in. long. The crop can then be cleaned out and the outlet cleared. This is not by any means a pleasant job, as the smell is very offensive, especially if the bird has been suffering for any length of time. Having thoroughly cleaned out the crop, the edges of the cut must be neatly brought together and sewn with white silk, using a surgical stitch—that is, making each stitch complete in itself. After sewing the crop skin, the outside skin must be treated in a like manner. The greatest care must be taken that the crop is not sewn to the outside skin. After the operation the bird must be fed only on soft food for a week at least, and then gradually broken in to hard food again.

BUMBLE-FOOT.—This is a swelling of the foot, which is caused by the fowls jumping from a high perch on to a hard floor, or from fighting through wire netting with other birds. If it is noticed early, frequent applications of iodine ought to effect a cure, but, if that fails, then the swelling must be cut and the matter extracted. To do this, make a cross cut in the foot and the matter can be worked out. Then wash the wound thoroughly with a weak solution of carbolic and hot water, and bandage. Keep the bird in a well-bedded coop for about a week or ten days, and it will then be all right again, if all the matter has been extracted.

CHOLERA.—The most deadly—in Australia about the most uncommon—disease is cholera. Although there are some who claim that birds suffering from this can be cured, it is very doubtful indeed, and in the instances of cures said to have been effected, the writer doubts if it were really cholera, as the symptoms of other diseases closely resemble those of this complaint. The cause is generally impure water, and the principal symptoms are as follows:—The affected bird mopes about by itself and seems to have an unquenchable thirst, while the droppings are of a bright green colour and watery. Do not try to cure a bird that you are convinced has cholera, but chop its head off and *burn* it. Then clean out all the drinking vessels and feeding troughs with boiling water, and thoroughly disinfect all the houses and nests with linewash to which has been added about 2 per cent. carbolic oil. This is to prevent the disease from spreading.

A LARGE STATION.

We have some fairly large cattle stations in Australia, but no consolidated run here comprises 30,000 square miles. Such an area is, however, held in Chihuahua, in Mexico, by Don Luis Terrazas. This large territory extends for 150 miles from north to south, and 200 miles from east to west. That is to say, that the millionaire owns a property which may best be imagined by drawing a line from Brisbane to Bundaberg towards the north, and from Brisbane to Miles towards the west, and connecting these by two lines meeting near Banana. On this enormous area the Don runs 1,000,000 cattle, 700,000 sheep, and 100,000 horses. He employs over 2,000 shepherds, horsemen, cowmen, hunters, and line men. All slaughtering and meat packing are done on the station, 150,000 cattle and 100,000 sheep being slaughtered annually at its meat works. The farm-house is the most magnificent in the world. It cost £32,000 to build, and is more richly furnished than many a royal palace.

In the Argentine Republic there are farms of enormous extent. One land holder, General Julio A. Roca, twice president of the Argentine Republic, has 192,000 acres in alfalfa (lucerne), or 300 square miles. Messrs. Salaberry, Labor, and Bercetche, of Cordoba, have nearly 100,000 acres more, and La Germania Estancia Land Company about 110,000. There are also many who own large areas planted in alfalfa far exceeding the Texas man. Mr. McKeon himself claims to have ten times as much as Mr. Smythe (1,400 acres under lucerne), and is now putting down 4,800 acres additional. This looks great news for the beekeepers, for in South America the cattle are allowed to graze on the alfalfa almost the year round. In Chili and Peru there are also vast areas set aside for alfalfa. As a matter of fact, the culture of alfalfa in this country is only in its infancy, and in time we shall see similar areas in Texas and California.





c.t.m.

Strombosia *partidiseorum*, *form.*

Botany.

CONTRIBUTIONS TO THE FLORA OF BRITISH NEW GUINEA.

By F. MANSON BAILEY, F.L.S., Colonial Botanist.

The plants enumerated in this paper were collected by Mrs. H. P. Schlencker at Boku, in British New Guinea, in 1908. Some of those mentioned, although enjoying a wide range in tropical countries, have not to my knowledge previously been recorded for British New Guinea, although they are recorded from Kaiser Wilhelmsland; others are probably rare in parts which have been visited by botanical collectors, thus a notice in this Journal may be useful to many.

Order STERCULIACEÆ.

Sterculia quadrifida, *R. Br.* See *Ql. Fl.*, 136. Papuan name, "Masena."—*Mrs. Schlencker.*

Order TILIACEÆ.

Sloanea paradisearum, *F. v. M.* *Papuan Plants*, 85. Baron Mueller says—"I have given this plant its particular specific name because it came from the forest haunts of the birds of Paradise."

A tree, attaining a height of 40 ft. Leaves crowded at the ends of the branchlets, oval-oblong, obtuse or acuminate at the apex, cuneate or rounded at the base, serrate and crenulate on the somewhat wavy margins, 4 to 7 in. long, 2 to 4 in. wide; petioles, $\frac{1}{2}$ to $1\frac{1}{2}$ in. long, slightly hairy as well as the midribs. Flowers, unknown. Fruit, a woody echinate capsule with a dense covering of straight bristles, 1 to $1\frac{1}{2}$ lines long; 3 or 4 celled, 3 to 4 in. long. Seeds forming 2 rows, and numbering about 16 in each cell, sessile, oval-elliptical, angular from mutual pressure, entirely included in a yellow or orange-coloured arillus, thus rather more than $\frac{1}{2}$ in. long. Cotyledons almost as long as the albumen; radicle very short.—*F. v. M.* in part.

Order LEGUMINOSÆ.

TRIBE PHASEOLEÆ.

Flemingia strobilifera, *R. Br.*, in *Hook. Fl. Brit. Ind.* ii. 227. An erect shrub, 5 or more feet high; the branches slender, terete, velvety. Leaves obovate, subacute, broadly rounded at the base, subcoriaceous, 3 to 6 in. long, glabrescent above, thinly silky on the underside, ribs raised, erecto-patent parallel; petioles $\frac{1}{4}$ to 1 in. long. Raceme axis zigzag, 3 to 6 in. long. Bracts cordate, $\frac{1}{2}$ to 1 in. long, membranous, finely downy, rather broadened than long. Calyx $\frac{1}{4}$ in. long, teeth lanceolate, exceeding the tube. Corolla purple, little exerted. Pod oblong, turgid, under 1 in. long, 2-seeded. There are several varieties of this species met with in tropical countries.

TRIBE DALBERGIEÆ.

INOCARPUS, *Forst. Chas. Gen.* 65, t. 33.

I. edulis, *R. and G. Forster.* Papuan name, "Quaba," *Mrs. Schlencker.* A tall, erect tree, bark smooth, branches spreading or drooping. Leaves alternate, oblong, emarginate, entire, of a glossy green, 6 to 12 in. long, and 3 to 4 wide. Stipules minute or caducous. Spikes or racemes solitary or in pairs, shorter than the leaves. Flowers yellowish, fragrant. Calyx bilabiate. Corollas funnel-shaped, 5-cleft. Stamens 10 in a double-series, inserted in the tube; anthers oval near the mouth of the corolla. Ovary superior, 1-celled, containing 1-ovule, attached at the top of the cell. Drupe obliquely oval, flattish, $2\frac{1}{2}$ in. broad, and 1 in. thick, of a fibrous texture, somewhat yellowish when ripe. A native of the islands of the Pacific Ocean and the Indian Archipelago. Wherever grown the fruit is prized for food.

Order ROSACEÆ.

Rubus moluccanus, *Linn.* See Ql. Fl., 526.

Order RUBIACEÆ.

TRIBE NAUCLEÆÆ.

Uncaria appendiculata, *Benth.*, in Hook. Lond. Journ. of Bot. 11, 222. A rambling plant, the branches 4-angular and pubescent, leaves ovate-rotundate, subcordate, 3 to 4 in. long, 2 to 3 in. broad, hairy-tomentose on the under-side, less so on the upper. Stipules bipartite, long as the petioles. Peduncle 1 to 2 in. long, rusty-hairy, tapering upwards, involucrate and articulate above the middle. Calyx short, segments linear with teeth between them.—*Benth. l.c.*, in part. Like our Australian species, this species also might likely yield a catechu of equal value to Gambier or *Terra japonica*, a commercial product. See note, page 746, Ql. Flora.

TRIBE MUSSLENDEÆ.

Mussaenda frondosa, *Linn.* In the packet were three forms of this beautiful plant, the material, however, was insufficient for determination.

TRIBE PSYCHOTRIÆÆ.

Geophila reniformis, *D. Don.* See Ql. Fl., 772.

TRIBE IXOREÆ.

Ixora timorensis, *Dcne.* See Ql. Fl., 765. Papuan name, "Loku."—*Mrs. Schlencker.*

Order LOGANIACEÆ.

Fagraea morindæfolia, *Blume Rump.* 11-32 and *Mus. Bot.* 1-169. A rambling shrub. Leaves ovate-oblong, 6 to 10 in. long, shortly acuminate, 4 to 5 in. broad, subundulate, the margins often recurved, on stout petioles of about 1 in. Flower-racemes with peduncles from 1 to 1½ ft.; the flowers in dense cymes on short peduncles. Flowers about 1 in. long, corolla-tube ventricose, lobes spreading. Berry about 1 in. long, ovoid-elliptic.

Order SOLANACEÆ.

Physalis minima, *Linn.* See Ql. Fl., 1092. Papuan name, "Godu Karava."—*Mrs. Schlencker.*

Order SCROPHULARINEÆ.

Vandellia crustacea, *Benth.* See Ql. Fl., 1110.

Order ACANTHACEÆ.

Justicia Gilligani, *Bail.* Ql. Agri. Journ. iii., 157.

Order VERBENACEÆ.

Clerodendron floribundum, *R. Br.* See Ql. Fl., 1183.

Order LABIATÆ.

Moschosma polystachyum, *Benth.* See Ql. Fl., 1188. Papuan name, "Loga."—*Mrs. Schlencker.*

Order NEPENTHACEÆ.

Nepenthes Kennedyana, *F. v. M.* See Ql. Fl., 1278.

„ *Cholmondeleyi*, *Bail.* See Ql. Fl., 1281.

Order ARISTOLOCHIACEÆ.

Aristolochia indica, *Linn.* See Ql. Fl., 1283.

Order PIPERACEÆ.

Piper caninum, *Blume*, *Hook. Fl. Brit. Ind. v. 82*. A rambling climber, hirsute, pubescent, or glabrate, branches slender terrete. Leaves membranous ovate, ovate-cordate, or lanceolate acuminate, rarely elliptic-lanceolate, 3 to 5 nerved towards the base, 2 to 4 in. long, $1\frac{1}{2}$ to 2 in. broad. Male spikes 2 to 3 in. long, bracts adnate by a broad base; stamens 2; anther-cells distinct. Fruiting recemes 1 to 2 in. long, including the peduncles; bracts peltate, villose. Fruit 2 lines diam.; pedicel variable in length, always shorter than the fruit. There are several named varieties of this species, and perhaps several of these are to be met with in British New Guinea.

Order CASUARINEÆ.

Casuarina equisetifolia, *Forst. See Ql. Fl., 1490*. Among the specimens were some to show the peculiar flabellate fasciation of the genus.

Order CUPULIFERÆ.

TRIBE QUERCINEÆ.

Castanopsis, *Spach*. Habit and character of *Quercus* Sect. *Chlamydoalanus* differs in the closed fruiting involucre, enclosing 1 to 4 nuts, and being covered with clusters of spines or tubercles, and often splitting irregularly.—*Hook, Fl. Brit. Ind. V. 619*. The species are met with in India, America, Malay Archipelago, and South China.

C. Schlenckeræ, *Bail. sp. nov.* (After the collector, Mrs. Schlencker, of British New Guinea, a daughter of the late J. G. Cribb, to whom Queensland is indebted for the introduction of varieties of American fruits, &c.) An evergreen tree of graceful habit and medium height. Papuan name "Iaro," *Mrs. Schlencker*. Branchlets very dark coloured, prominently striate, and dotted with white lenticels. Leaves broad lanceolate, with long narrow points, margins wavy, about $3\frac{1}{2}$ in. long, $\frac{3}{4}$ to $1\frac{1}{4}$ in. broad; petioles slender, $\frac{1}{4}$ to $\frac{1}{2}$ in. long; upper side of leaf-blade glabrous, dark-green, under-side thinly tomentose, whitish; nerves arched, about 9-pairs, the reticulate veins very close, but faint. Inflorescence terminal and in the axils of the upper leaves; sometimes solitary, slender, monœcious spikes, but mostly forming elongated panicles of slender, erect, or drooping branchlets, about $2\frac{1}{2}$ in. long, bearing sessile male and female flowers. Bracts densely-hairy exceeding the perianth. Perianth cup-shaped, about 1 line diam., very hairy inside at the base, hairs white. Stamens about 10, twice as long as the perianth; filaments hairy, anthers rather large. Involucre about 6 lines long and 4 lines broad, somewhat 3-angular, the side facing the axis without tubercles, the others with scattered tubercles solitary or in clusters, the points hard and glabrous, the whole outside of the involucre clothed with a thin tomentum, the inside with appressed silky hairs, more or less split at the top, showing the rusty-hairs with which the nut is clothed and the remains of the stigmas at its apex. The nuts are used for food by the Papuans.

Order CYCADACEÆ.

Cycas papuana, *F. v. M. Papuan Plants, 71*. Papuan name, "Warnara," *Mrs. Schlencker*. Petioles unarmed; segments of leaves rather short and narrow, flat, glabrous, opaque beneath, not pungent, sessile, with broad slightly decurrent base. Fruit rhachis, velvety-downy, long-stalked; its terminating lamina hard, rhomboid, acuminate, toward the summit toothed, at the apex short-laciniate, on the upper side finally glabrescent. Fruits several, ovate-globular; from the commencement glabrous. On the Fly River—D'Albertis. The above is F. v. M.'s notice, i.e. I have only fruits in the packet of specimens under notice.

Order ORCHIDEÆ.

Eria australiensis, *Bail. See Ql. Fl., 1541*. Judging from the solitary specimen to hand, it cannot be separated from the Australian species.

Order SCITAMINEÆ.

Curcuma australasica, *Hook.* See Ql. Fl., 1593.

Order COMMELINACEÆ.

Commelina ensifolia, *R. Br.* See Ql. Fl., 1652.

Order GRAMINEÆ.

Panicum hermaphroditum, *Stend.* See Ql. Fl., 1829.

Coix Lachryma-Jobi, *Linn.* See Ql. Fl., 1848.

Order LYCOPODIACEÆ.

Selaginella Palu-palu, *Bail.* Ql. Agri. Journ. ix., 215.

Order FILICES.

Lygodium dichotomum, *Sic.* See Ql. Fl., 1934. From the outer rind of the smooth stems the Papuans obtain material which they plait into armlets and bracelets.—*Mrs. H. P. Schlenker.*

Marattia fraxinea, *Sm.* See Ql. Fl., 1944.

Gleichenia flagellaris, *Spreng.* See Ql. Fl., 1938. This is put to the same use as the *Lygodium*. Papuan name, "Gana."—*Capt. F. R. Barton.*

Trichomanes javanicum, *Blume.* See Ql. Fl., 1944. These specimens were more or less covered by the hair-like sterile mycelium of a fungus, probably *Marasmius equicrinis*, *F. v. M.* Horse-hair fungus. The caps should, however, be looked for, as the species may prove new.

Dicksonia davallioides, *R. Br.* See Ql. Fl., 1950.

Davallia parallela, *Wall.* A Malayan and Polynesian species.

Lomaria capensis, *Willd.* See Ql. Fl., 1964.

Polypodium phymatodes, *Linn.* See Ql. Fl., 1985. I take the opportunity of publishing another *Polypodium*, a fertile frond of which I received some time ago from the Rev. Copland King, of British New Guinea, namely:—

P. (Lecanopteris), Curtisii, Baker. *Hook.* Ic. Pl. 1607. Rhizome, hard, woody, this portion to hand, about 2 in. long and 1½ in. broad, seems to have been taken off rock or bark, showing to have borne 6 fronds, the bases of which for a short distance up are swollen and connected with each other, and probably when fresh were of a succulent or spongy character, but in the dry state have the appearance of crumpled glaucous leather. Stripes articulate about ¼ in. above the swollen part, then somewhat angular for about 5 in., and like the rhachis of a bright brown. Frond deeply pinnatifid, lanciform in outline, about 14 in. long; pinnæ horizontal, about 2 in. long, 3 to 5 lines broad. Sori marginal, occupying the whole of an oval lobe, from 1 to 1½ lines long. These fertile lobes are situated at the crenulations of the pinnæ. Venation primary erecto-patent, the anastomosing veins mostly hidden in the substance of the frond. Mr. J. G. Baker gives Sumatra as the habitat. Perhaps this plant, when better known, may prove only another form of *P. (Phymatodes) lomariodes*, *Kunze.*

Grammitis involuta, *Don.* Prodr. p. 14. *Hook.* Spec. Filic. v. 155, as *Gymnogramme (Selligenea) involuta*, *Don.*

Caudex long, creeping, paleaceous at the apex, with broad lanceolate-scales, stipites subaggregated, stout, but compressed and winged. Fronds carnosu-coriaceous, a span to 1 to 1½ ft. long, ¾ to 3 in. wide, simple lanceolate-acuminate, much attenuated at the base and narrowly decurrent on the stipes; costa broad, compressed, pale-coloured. Venation immersed, obscure; primary veins oblique, subcostuliform, very slender, connected by a network of secondary veins forming subuniform areoles with larger costal ones, sometimes including free veinlets. Sori linear, elongated, erecto-patent, but varying a good deal in direction, not quite extending to the costa or the margin.—*Hook.* l.c. Common in the mountain districts of India. The Papuan specimens show a small form or growth, the fronds being only about 7 in. long, and scarcely 1 in. broad.

The Orchard.

CODLIN MOTH-PROOF APPLES.

A correspondent of "N. Z. Farmer" writes:—Through many years I have observed, and have been very much struck with the fact, says an Australian correspondent, that in an orchard of 15 acres of badly-infested apples I never saw two varieties—the Keswick Codlin and Devonshire Quarrenden—affected by the codlin grub. The Keswick Codlin holds the first place in the Northern and Midland Counties of England as the earliest and best-cooking apple, and a good bearer, and this description equally applies in Victoria. The bearing properties of this apple-tree are something phenomenal on rich loams. Devonshire Quarrenden dessert is, in most people's estimation, the best early, and under good treatment one of the most prolific bearers. I have taken as much as 30 bushels of good fruit in one season off a single tree. Those two varieties want more space than 20 ft. each way for their great bearing capabilities and good treatment. In the same orchard was Red Cluster, a rather showy apple, but only of second quality. It grew close to acres of badly-affected Ribston Pippins, but no codlin moth attacked it.

FIGHTING THE CODLIN MOTH.

How to combat the codlin moth is, says "N. Z. Farm," a very live question in Australia, as well as other parts of the world. Up to the present our experts have not pinned much faith in the discovery of a parasite which will attack the pest in the grub state. They point out that this method of attack would only minimise the evil. All the same, much interest attaches to the parasite which was recently discovered at Gosford, and the departmental officers are probing the possibilities of this friend of the apple-producer. Strange to say, only a few weeks ago a parasite of a different kind was struck in South Australia. The expert in Victoria, Mr. French, points out that frequently it has been discovered that species of the ichneumon fly lay their eggs in the moth's crysilids with good results; but, unfortunately, several insectivorous birds, in turn, prey upon the insects. These same birds not long ago ate up a ladybird which had been introduced in Victoria for the purpose of warring against the cabbage aphid. Mr. French contends that the best method of attacking the codlin moth is to spray with arsenate of lead, thus ensuring 98 per cent. of clean fruit. The moth is gradually decreasing in Victoria because of the general use of the spray referred to.

SULPHUR FUMES FOR PRESERVING FRUIT.

Peel peaches, cut in halves and remove seeds; arrange in wooden tub, leaving a hole in centre for vessel that is to contain the sulphur. If 4 gallons of fruit is desired, pare enough fruit for 6 gallons, as this allows for shrinkage. When fruit is in tub, place sulphur at the rate of 1 teaspoonful to each gallon of fruit used, in vessel in centre of tub, ignite it and cover whole tub closely for 4 hours. Remove fruit, and place in stone jars; cover with a cloth. Fruit preserved in this way keeps fine all winter, and tastes like fresh fruit. Apples, pears, or tomatoes are delicious prepared this way.

Apiculture.

PROSPECTS OF AN EXPORT TRADE IN HONEY.

Mr. R. Beuhne, President of the Victorian Apiarists' Association, who was last year commissioned by the Minister for Agriculture (Vic.) to inquire into the prospects of establishing an export trade in Victorian honey, and report generally on apiculture as practised in the United Kingdom, Germany, and the United States of America, furnished, on his return to Melbourne, a very interesting report on the information collected by him concerning apiculture generally. He found the usual prejudice against the alleged eucalyptus flavour in Australian honey, although some of the importers were prepared to give Victorian honey some preference for manufacturing purposes on account of its greater density provided regular supplies could be depended upon. The price offered was 2½d. to 2½d. per lb. at port of arrival for palest samples—Yellow Box and Red Gum—and somewhat less for other. At this time the prices ruling for Jamaica and Chili honey in London were from 20s. to 32s. per cwt., and New Zealand honey, which is gathered from clovers and non-eucalypts, realized up to 45s.

One of the principal London dealers' firms, Messrs. A. Bredenberg and Co., held out no hope of our honey even getting a footing as table honey on the English market at anything like the price now obtainable for English honey. It is considered too strong for table use. When they were paying 32s. per cwt. for fine white set Jamaica honey, Australian was offering at 28s. in 1-cwt. cases containing two tins each. The report deals further with the method of creating a market, and marketing, shipping in bulk, and various other matters of vital interest to apiarists, and concludes with an account of legislation in other countries in connection with bee diseases.

The report will be found in the issue of the "Journal of Agriculture of Victoria," 10th November, 1908.

SOME USES FOR HONEY.

It is but rarely that we see honey on the table as regularly as jam; yet it is a far healthier food than the latter. Take the following from the "British Beekeepers' Review" on "Honey as a Food and Medicine":—The wisest man that ever lived advised his son to eat of honey, "because it is good"; and Democritus, who lived to be a centenarian, attributed his freedom from illness and his prolonged life to partaking of honey as a regular part of every meal. Just lately we heard of a young lady, whose life was despaired of by the doctors, being spared, and recovering by the regular use of honey as a food. Scientists inform us that honey contains almost all the requirements of life-supporting food, added to which it requires little or no digestion. We are also informed that its use helps the intestines and the kidneys in performing their special functions. For growing children who crave for sweets, nothing better than honey could be given. Mahomet discovered this important truth before he wrote the Koran, where he speaks of honey as "this sweet wholesome substance, which sustains and strengthens the body, which cures all maladies, a thousand times preferable to the poisons administered by the doctor to the human race." Recently a doctor declared that he cured several stubborn cases of constipation by the steady use of honey, prescribing no

other medicine. In cases of nervous disorders it has been long recognised as an excellent tonic. Cuts, scratches, small wounds, chips, scalds, burns, and many similar small ills have been cured by an application of honey, or a salve in which honey formed the chief ingredient. Colds, coughs, sore throats, asthmatic irritation are frequently treated with honey. Bronchitis has been, if not cured, at least greatly relieved by its free use. Many very palatable drinks can be made from honey, and in hot summer weather no better use can be found for honey than converting some of it into a cooling and refreshing drink. Honey biscuits are pleasant eating, and should find a place on every tea table. Honey sweets have an agreeable and appetising effect on the palate. Honey vinegar is the best and most pleasant form in which this bitter relish can be found.

MEAD.

We have on former occasions given recipes for making mead, but the following appear to us to be more satisfactory:—

Use 4 lb. of honey to each gallon of water; put it in a copper and boil it; skim till no scum arises, then put to each gallon $\frac{1}{2}$ -oz. of hops. Boil half an hour longer, and drain while hot into a clean and sweet barrel. When lukewarm add $\frac{1}{2}$ -oz. of yeast, which stir in the liquor. Bung down when it ceases working.

Symington's recipe is: Put 3 lb. of the finest honey to 1 gallon of water, and two lemon peels to each gallon. Boil it half an hour (well skimmed), then put in while boiling the lemon peel. Work it with yeast, then put it into the barrel with the peel, and bottle off in five or six months. If the mead is to be kept some years use 4 lb. of honey to the gallon.

Most of the recipes, briefly put, are in the following proportions:—One gallon of water, 4 lb. of honey, $\frac{1}{2}$ -oz. of hops, lemon according to preference, and 1 tablespoon of brewers' yeast.

NEW ZEALAND FLAX MILLS.

About four months ago we had a visit from a gentleman from New Zealand interested in the flax trade. He drew a rather doleful picture of the position of the flax mill owners, which was so precarious, owing to low prices for the fibre, and distance of many of the mills from the ever-decreasing source of supply, that he predicted the closing of many flax mills at no distant date. That his prediction has been verified is shown by the fact that at the present time there are only twenty-four flax mills, with a monthly output of about 950 bales, in active operation in Otago and Southland, as against seventy at this time last year. The swamping of the London market with Manila hemp (says the Otago "Daily Times") is a potent factor in regard to the industry here, and so long as prices keep as low as they are at present there will be few mills starting operations. The conditions ruling at present will, however, have a beneficial influence, in that flax areas—which by reason of the fact that they were being drawn on every three, and, in some cases, two and a half years, thus producing over-straining of the plants, four years' growth being required to bring the flax in this part of the Dominion to the point of maturity—will be all the better for this compulsory rest, and be more prolific when the next season takes up.

Horticulture

FLOWER GARDENING, No. 14.

PLANTS SUITABLE FOR IN AND OUT DOOR CULTURE.

By THE EDITOR.

HOYA (Wax Plant).

The Hoya may be seen festooning the trees in many of the scrubs in Queensland. They are not very showy plants, but are exceedingly interesting, climbing by means of adventitious roots, which attach themselves, like ivy, to the surface with which they may come in contact.

Hoya carnosa is the most popular; it is commonly designated "Wax Plant" or "Honey Plant," the first, from the wax-like appearance of the flowers, and the other from the drop of nectar which hangs from each flower. This variety will thrive in an ordinary greenhouse. The Queensland indigenous Hoya is known as "*Hoya australis*," and is a very elegant species. The Hoyas require a well-drained soil, and do best if old lime and brick rubbish are mixed with it.

VARIETIES.

H. carnosa: A beautiful climber, with thick fleshy leaves and beautiful clusters of pinkish-white flowers, which look as if frosted. *H. carnosa variegata*: This variety can be grown out of doors against a brick wall in a warm aspect, but is seen to best advantage when grown in pots in a greenhouse. *H. bella* is more of a dwarf pendant bush than a climber; its flowers are very pretty. *H. imperialis* is a grand and very robust climber, with very large flowers.

STEPHANOTIS FLORIBUNDA.

This is one of the most lovely of the climbers, and its flowers are perhaps the most popular; they are exceedingly valuable to the florist and bouquet-maker, and are prized as first-class plants for exhibition. In the Southern States of the Commonwealth they are usually grown in the greenhouse, but in Queensland they thrive out of doors as well. The foliage is wax-like, and the flowers are pure white, and produced in abundant clusters. The plant may be grown in a pot and trained to a trellis, but is finest when in free soil, or in a large tub and trained to the roof. Great care should be taken to protect it from the mealy bug. The plants require a large supply of water, but less when growth has ceased. Pots should be well drained.

GLORIOSA.

This genus, so named from its magnificent flowers, ought to do well in Queensland. There are few species, but all are splendid. *Gloriosa superba* is the best known. It is a herbaceous perennial with tuberous roots, and does best in a rich sandy compost. The soil should be kept rather dry in winter, but great heat and moisture are required afterwards until the plants are in flower, when a lower temperature will cause the flowers to last longer. The leaves terminate in tendrils, which cling to other plants for support. They require a tall trellis, as the shoots attain a length of some yards.

VARIETIES.

Gloriosa Rothschildiana: This is a new plant, a magnificent climbing lily, first discovered in the Uganda district, near Lake Victoria Nyanza. It is the handsomest of the genus, its pure, glowing, crimson flowers constituting it one of the glories of tropical plants. On a single specimen thirty-seven flowers have been produced.

Gloriosa Rothschildiana citrina: The "Florida Agriculturist" says of this plant:—"A fine plant of *G. superba* clambers up among the branches of *Lasiandra macrantha*, and the contrast between the deep violet-purple flowers of the *Lasiandra* and the yellowish lilies of the *Gloriosa* is an indescribably beautiful one. *Gloriosas* have been grown in the poor, dry, sandy soil of Orange Co., Florida, and though they flowered well, and were great objects of beauty, they only show their full charm when grown in moister and richer soil. Some of the specimen plants are 9 ft. high. The tubers were planted in a mixture of leaf mould, old cow manure, and sand. The tubers, which are tooth-like in appearance, and often forked, are exceedingly brittle, and have to be handled very carefully. They are all perfectly hardy in Florida, and ought not to be disturbed after being planted. Only plants left in their places for years form large and fine specimens. A small tuber planted three years ago has pushed up three very vigorous flower stems, besides two small ones.

"The genus is divided into two sections—viz., the climbing and the dwarf, or non-climbing. All the species are natives of Africa, although *Gloriosa superba*, which is very common in western Africa, is widely distributed in tropical Asia as well. *Gloriosa virescens* is a species doing also very well in Florida. The flowers are deep orange and yellow. The segments are spatulate, and the margin not crispate, and but slightly undulated. *G. Plantii* is a variety of this species, with reddish-yellow flowers. The type was introduced from Mozambique. Another variety of this species is *G. Leopoldii*, with yellow flowers.

"*Gloriosa grandiflora* has wholly yellow flowers, the reflexing of the segments and their undulation approaching *G. superba*. *Gloriosa abyssinica* is an erect species, growing only 1½ to 2 ft. high, coloured like those of *G. virescens*, but with broader segments, not at all crisped at the margin. At present the still finer variety, *Gloriosa Rothschildiana citrina*, flowers side by side with the common species, *G. superba*, of which a grower in Orange Co., Florida, U.S.A., Mr. H. Nehrling, has about 100 blooming plants. The latter appears insignificant as seen in such close proximity with this gorgeous new comer. The plant is large and vigorous, about 7 ft. high, and the leaves are large, broad, and are arranged opposite along the stem. The flowers are about three times as large as those of *G. superba*. When opening, they are of a clear citron-yellow, with a feather-like band of a deep ruby-crimson up the middle of each segment. As the flower matures, the yellow assumes a more chrome tint, and the ruby-coloured band widens, while later the ruby colour suffuses the whole flower as it passes out of bloom. The colours of the flower, its large size, and exquisite form, are unique in the genus, and, like the type, the variety is a great acquisition. A beautiful illustration of the type appeared in 'The Gardener's Chronicle,' 23rd May, 1903, and of the variety, 16th September, 1905." The American florist has crossed the first flower of this variety with the pollen of *G. superba* and *vice versâ*, and hopes to obtain a number of distinct hybrids. *Gloriosas* come into flower within a year after the seed has been sown, if grown in rich soil.

"*Gloriosa Carsoni* is a fine new species. The first tubers were collected in the neighbourhood of Lake Tanganyika. It flowered for the first time at Kew in June, 1904. It is a very beautiful species, making a strong growth some 6 ft. in length, terminated by several flowering branches. The flowers have a diameter of 4 in., the colour of which is brownish-red, each segment having a margin of golden yellow. *Gloriosa minor*, from North-eastern Equatorial Africa, is a singular plant, the flowering specimens of which are only 3 or 4 in high. With regard to the stability of the characters, 'climbing' and 'dwarf' or 'non-climbing,' it is very probable that under certain circumstances the climbing plants may become dwarf, as do many climbing plants under cultivation when the means of climbing are lacking. By the same rule the non-climbing, I am inclined to think, might assume a climbing

habit if growing in woody districts, or in places where the use of the prehensile, tendril-like continuation of the leaves would enable them to rise to a situation more favourable to the production of their flowers if crowded by a strong-growing vegetation. All the species, dwarf and climbing, have in a greater or less degree these tendril-like continuations of the leaves except the very small *G. minor*, from which perhaps ages of existence in open situations, and probably in very shallow soil, have almost if not entirely eliminated this feature. There are a few plants allied to the Gloriosas which do very well in Florida, requiring the same treatment and showing the same habit, though not quite as showy." The climate of Queensland being very similar to that of Florida, should be well adapted for these showy plants. They appear above ground in July.

LOPHOSPERMUM.

This is another handsome climber (annual), which grows to a height of 10 ft., and bears large purple flowers. Sown in Autumn and Spring, in boxes, it may be planted out in a sheltered position as soon as the young plants can be safely handled.

MINA LOBATA.

A half-hardy climber. The flowers are in long racemes; when in bud, they are a vivid red, becoming orange-yellow before opening, and creamy-white when fully expanded. The whole plant is strikingly beautiful, the shoots attaining a length of 20 ft. The seed should be sown in Spring.

THUNBERGIA.

The Thunbergias are very pretty climbers, producing large quantities of flowers. If well grown, nothing can be prettier. They are half-hardy annuals of a twining habit, and grow rapidly to a height of about 36 in. Sow the seed in Spring in a compost of leaf mould, loam, and sand.

T. aurantiaca and *alba* are about the best varieties.

IPOMÆA.

The Ipomæas are beautiful climbers, valuable for covering trellises and fences. They have handsome convolvulus-like flowers, fine foliage, and are rapid growers. Hardy annuals, except *Learii*, which is a perennial, with deep-blue flowers. Sow in Autumn and Spring.

SOME GOOD VARIETIES.

Halepacta superba: Ivy-leaved, various colours; Mikado, brilliantly coloured flowers. *Grandiflora alba*: Magnificent white flowers. *Bona nox*: Bears most beautiful, large blue flowers, sweet-scented, which open in the evening. *Learii*: Deep-blue flowers. *Quamoelit* (The Cypress Vine): A distinct variety, having elegant feathery foliage, with clusters of small scarlet flowers.

MOONFLOWER (Calonyction).

This is a very strong grower, and spreads to a great distance. It thrives to perfection in this State, and may be seen in many gardens. The leaves are heart-shaped and bright green. The fragrant white flowers, 6 in. across, are produced in great profusion, and open in the evening. There is a new hybrid of the Moonflower, the flowers of which are larger, coming into bloom sooner, and opening earlier in the evening than those of the original Moonflower.

WISTARIA.

Wistaria sinensis is a large, strong-growing, climbing shrub, bearing large racemes of pale-purple flowers. *W. sinensis alba* is a white variety of similar habit and growth. In this State it flowers in September and October, and, after flowering, puts forth a mass of handsome pinnate foliage. Sir J. Paxton said that rigid pruning is indispensable to make it bear, on spurs.

instead of on big branches, and plants, cut down to within a short distance of the ground, acquire a shrubby habit, and the produce flowers in abundance. That, however, has not been my experience, as I had to cut close to the ground a fine plant, with runners 20 ft. long, in order to admit of painting my house. The plant very soon assumed its former proportions, but it only put forth three flower racemes instead of dozens. The soil where the *Wistaria* is to grow should have a good quantity of sand mixed with it. It is propagated by layers and cuttings of the ripe wood.

VARIETIES.

W. Bidwilli; *W. magnasperma*; *W. sinensis*, bearing beautiful deep lilac flowers; *W. sinensis alba*, which is a white variety.

JASMINES.

These are too well known to need much description, but they cannot well be left out of a list of hardy climbers, as there is a considerable variety of them, and they are all graceful plants, with sweetly-scented flowers. Nearly all of the *Jasmines* are white, but there is a very handsome yellow one hailing from India. The flowers are a clear yellow, resembling in shape the perennial phlox.

VARIETIES.

J. grandiflorum resembles in leaf, flower, and fragrance the common English Jasmine; *J. heterophyllum*; *J. sambac* (Arabian Jasmine); the Double Arabian, or Tuscan Jasmine, bears flowers like little white roses; *J. scandens* bears corymbs of numerous, pure white, delightfully fragrant flowers.

CANARY CREEPER (*Tropæolum canariensis*).

A pretty, tender annual climber, of great beauty. The foliage is small, and the flowers golden yellow, somewhat resembling the form of an insect. It grows in course of time to a considerable height, and requires a trellis for its support. It cannot endure great heat; the seeds should, therefore, be raised in pots or boxes, and planted out in the Spring in some sheltered position.

PASSION FLOWER.

The different species of Passion Flower are rather numerous, but only some five or six are of any value in an ornamental point of view. They are tendrill-bearing climbers, and grow with great rapidity, but soon exhaust the soil. They are easily grown from seed. The edible fruit-bearing variety is so well known in Queensland as to require no description here. It bears fruit twice a year.

VARIETIES.

P. alata: Calyx and petals, crimson; rays, variegated, white, purple, and crimson. *P. kermesina*: The most beautiful species in cultivation, except *P. racemosa*. The flowers are of a fine carmine crimson, and display themselves only where sheltered from the sun. *P. edulis*, *P. racemosa*: This very choice and handsome plant bears deep-red or scarlet flowers. Moss-rose Passion Flower: Otherwise called "Love-in-a-Mist," botanically known as *P. fatida*, is a very pretty, delicate climber, bearing aromatic edible fruits, contained in an outer covering, much resembling the involucre of the moss-rose. Grows wild in parts of Queensland.

BEAUMONTIA GRANDIFLORA.

A truly magnificent climbing shrub, with strong woody stem; spreads over an immense space its dense foliage-curtain of noble, verdant, oval leaves, 9 in. in length and 4 in. broad. Flowers trumpet-formed, resembling white lilies, 4 in. long and 3 in. across, with a faint, lily-like scent, borne

in large corymbs, and covering the plant with an entire mass of blossom. Propagated by cuttings or from seed. A very rapid grower.

There are many other pretty climbers which thrive well in Queensland, and which are so well known that they need not be described here. Such are: Icy-leaved Geranium, Honeysuckle, Nasturtium, Sweet Peas, Convolvulus, Ivy, Creeping Fig, *Bauhinia scandens*, &c.

CLIMBING ROSES.

Gloire de Dijon: Yellow and buff. La France: Beautiful blush. Maréchal Niel: Rich golden yellow. Reine Marie Henriette: Bright rosy cerise. Cloth of Gold: Sulphur yellow. Climbing Niphetos: Magnificent pure white tea. Devoniensis: Creamy white. Souvenir de Madame Metral: Bright cerise red. Souvenir de Malmaison: Edges blush, deeper in centre. Waltham Climber: Deep crimson. William Allan Richardson: Beautiful orange-yellow; and many others stocked by nurserymen.

BANKSIAN ROSES.

These are all desirable for climbing purposes. They include *Banksia alba*, white; *B. fortunei*, large white; *B. lutea*, yellow.

ORNAMENTAL SHRUBS AND SHRUB-LIKE PLANTS.

DRACÆNA (Cordylina).

This is a very popular genus, the numerous species and varieties being remarkably handsome when well-grown and in good health. Their culture is simple; they thrive in ordinary rich compost, and, if grown in pots, these should be large, and abundantly supplied with water. In the Queensland coast climate they do well in the open. They somewhat resemble a small palm, have an erect stem, naked to the summit, upon which its long, lanceolate, sharp-pointed leaves are borne. They are much in request, owing to the ornamental colour of their foliage—some of a crimson hue, others partaking of a bronze-like metallic lustre. They are propagated by the suckers which they throw up.

VARIETIES.

D. australis: Unlike any of the Cordylines; is described above. *D. Draco*, *D. fragrans*, *D. nutans*, *D. cannaefolia*, all handsome tropical-looking plants.

CORDYLINA (syn. Dracæna).

C. ferræa: Dark-green leaves with crimson edges; bears large compact bunches of very numerous, small, rose-coloured, very pretty flowers. *C. terminalis* (The Sandwich Island Tee-plant): Foliage rich, light verdant green; bears feather-like sprays of numerous small, pure white flowers. *C. reflexa*: Leaves green, bears yellowish-green, sweet-scented flowers.

HIBISCUS.

Although there is a considerable number of handsome species of this genus in Queensland gardens, and nearly all are beautiful, there is not sufficient diversity of character in many to make it worth while to cultivate more than a select few. Most of them are very easily propagated by cuttings or seed. They require little attention, flower in any soil, with or without shelter, and produce a profusion of lovely large flowers.

VARIETIES.

H. mutabilis: Changeable Rose, a very large bushy shrub, growing to a height of 10 ft., and produces a profusion of large, very handsome, double flowers, something like immense double roses; white on first opening, then becoming cream-coloured, and finally of a deep rose tint. *H. rosinensis* (Chinese Shoe Plant): In almost constant blossom, with its brilliant, crimson-scarlet flowers, with the long, pretty column of pistil and stamens projecting

from their centre. *H. Andersonii*: Dark crimson, with dark eyes. *H. chrysanthus*: Large-sized golden flowers, with a purple-crimson spot at the base, forming a dark-coloured eye; attains a height of 4 ft. *Syriacus*: This variety averages about 4 or 5 ft. high; bears large, lilac-blue flowers, with dark-purple eye. *H. S. alba*: Bears double white flowers. *H. Cooperii*: Red and white variegated. Besides these, there are other beautiful varieties to be obtained from our nurserymen.

CAMELIAS.

Camellias thrive well here out of doors in favourable situations, where they can be protected from hot winds in summer, and from frosts when in flower. They thrive in light loam, well drained. In favourable soil the trees will grow to a height of from 12 to 20 ft. With proper attention fine specimens can be grown in large pots or ornamental tubs. They continue in bloom from May to September. The Camellia is not hardy in the colder districts of the State. The single white variety is highly ornamental in the shrubbery. The plants should stand about 10 ft. apart, and should be planted out early in Autumn—about April.

VARIETIES.

There are several hundreds of varieties of Camellias, amongst which some of the best are:—*Alba plena*, double white; Angelo Cocchi, white, striped rose; Camile Brozzoni, crimson, with white stripes; Isabella, large handsome white; Nivalis, pure white; *Virginia franco*, rose, changing to soft pink; Jourvain, rose, shading to crimson; *Imbricata*, white, striped with rose; La Pace, white-shaded rose, striped crimson; Henri Favre, salmon rose, fine shape; Camilio Galli, imbricated, white and red; Dionesia Poniatowski, pure white; Lafevriana, very large rich rose, &c.

Camellias are propagated by in-arching and grafting upon the single-flowered, also by cuttings inserted firmly in sand in March or April, and set in a shady close frame. Camellias are not so susceptible to frost as is generally supposed; indeed, the single-flowered varieties succeed trained against north aspect walls. Notwithstanding their comparative hardiness, the very best hybrid, double-flowered varieties do not bloom well, though laden with flower buds, in a too cold, damp greenhouse, excess of atmospheric moisture within which rots the buds of some. The lowest winter temperature in such places should be between 35 and 45 degrees. Enduring as these plants appear to be—apart from occasionally shedding their flower buds—one fact must not be lost sight of—*i.e.*, that they only thrive well in a light, open compost, comprising equal parts of peat and fibrous loam, with somewhat liberal additions of silver sand, rotten cow dung, and nodules of charcoal, over efficient drainage. If potted somewhat firmly, their comparatively large roots soon take possession, and, with sufficient waterings with manure water occasionally at the growing season, they retain good health and bloom freely for from three to four years without repotting, though an annual mulching with fresh rich soil over the roots is beneficial. The best time to repot them is either just as they begin growing, or immediately the tender young shoots attain to their full length, and growth is improved by giving them a little extra warmth, bottom heat in particular, with overhead syringings. It is all-important to turn them out of doors immediately the young growths attain to their full length.

RHODODENDRON.

This is a charming plant, eminently suited to all the cooler parts of the State. It is a hard-wooded, evergreen shrub, producing magnificent heads of flowers of a variety of colours. Many varieties prefer, as stated, the cooler districts, such as the Darling Downs or Herberton, but there are several which will thrive in almost any part of the Southern districts, out of doors, provided sufficient protection from the sun and our very infrequent hot winds

can be given. Planted in a sheltered situation, they will thrive in a satisfactory manner. They like a peaty soil, but will succeed in any light loamy or sandy soil that has been recently broken up, but rarely do well in soil that has been cultivated. It is beneficial to the plants to mulch the soil with fresh cow dung, which helps to retain the moisture and to keep down the temperature. Rhododendrons are easily raised from seed, but many varieties are propagated by grafting on seedling stocks in pots.

VARIETIES.

R. Countess of Haddington: This hybrid, although one of the oldest, is amongst the most beautiful of the Rhododendrons. It has rather small, dark-green leaves, and large, long-tubed flowers, somewhat drooping, and of a delicate blush-white colour. It is supposed to be a cross between *R. Dalhousie* and *R. Gibsonii*. *R. Delavayii*: Flowers crimson, with black spots at base of the corolla. *R. intricatum*: Trusses five-flowered, corolla, violet or lilac, anthers orange-coloured. Other varieties are—*R. Veitchii*, *R. Duchess of Edinburgh*, *R. Princess Alice*, *R. Gibsonii*, *R. Ponticum*, &c.

ABUTILON.

A handsome family of evergreen, flowering shrubs, of free growth, suitable for any part of Queensland. Some of the varieties have variegated leaves, and are very handsome; but the whole family are attractive and profuse bloomers; their flowers are bell-shaped, and of various colours.

VARIETIES.

A. Bedfordianum: Bears large, pendulous, eardrop-like flowers with folded petals of a pale orange colour, prettily pencilled with brown lines. It should be renewed annually either from seed or cuttings. *A. marmoratum*: Produces beautiful erect flowers of the size and form of Canterbury Bells, rose colour, marbled with pure white veins. *Boule de Neige*, white; *Cloth of Gold*, golden; *A. Thomsonii*, orange and red. *Souvenir de Bonn*: Leaves have a margin of silver flowers, orange-yellow, veined with scarlet. *Golden Fleece*, yellow.

DATURA (Trumpet Flower).

This is a very large spreading shrub, with thick flaccid leaves. *D. suaveolens* makes a splendid appearance when in full blossom, with its immense, white sweet-scented flowers, of the size and shape of a cow-horn, the corolla expanded at the mouth with frilled edges. It does not yield seed, but is easily propagated by cuttings. *D. sanguinea*: A shrub of much smaller growth than the last, and leaves of a darker green: the flowers are also smaller and more tubular, with the rim curled over, of a dull deep red colour. *D. cerasifolia*: Large trumpet-shaped flower, beautifully sweet-scented, pink and white. *Double Golden*: A compact bush about 2 ft. high, bearing large golden, funnel-shaped flowers. Sow in Spring.

AZALEA.

The climate of Queensland is admirably suited to the cultivation of these beautiful shrubs, which are unequalled for richness and pureness of colour, and gorgeousness of display. They should be planted in masses, and a good strong soil is better suited for them than light soil, though they will succeed in either, provided it is not too dry. In very dry seasons they should be heavily watered about once a fortnight, but in seasons of normal rainfall such watering will not be necessary. Azaleas may be grown either out of doors, in the bush-house, or on the veranda as pot-plants. Pots should be 6 or 8 in.

VARIETIES.

Alba magna, large white; Alice, deep rose, large vermilion blotch; Neptune, flowers a brilliant orange; Duke of Devonshire, salmon red; Fielder's White, perfectly pure white; Empress of India, gracefully wavy flowers, carmine, white, and salmony-rose (double); Marquis of Lorne, bright orange, saffron, yellow blotch; Madeline, pure white; Dame Mélanie, very bright rose, edged with pure white, carmine blotch; *A. sinensis* (*A. mollis*): This is a handsome species, producing large yellow, or flame-coloured, bell-shaped flowers. There are numbers of hybrids, far too numerous for detailed description, but the principal nurserymen either stock most of them or can obtain them for the amateur gardener.

GARDENIA.

A most delightful shrub, with neat, handsome, glossy foliage; bears very large, double cream-white, sweetly-fragrant flowers, having much the appearance, in some varieties, as *G. florida* (Cape Jasmine), for instance. Gardenias are not very particular as to soil, but they thrive best in a warm situation. Some kinds will grow to a height of 6 or 8 ft.; but, by pruning, they may be kept to any small and convenient size. Propagated by cuttings.

VARIETIES.

G. florida, *G. globosa*, *G. magnifica*, *G. radicans*, *G. Thunbergiana*, *G. lucida*. The latter is a large shrub, or rather small tree, with rich, olive-green foliage. It bears, at intervals, large, handsome, solitary, fragrant, white flowers, 3 or more inches across; blossoms beautifully in a dwarf condition, in which state it may easily be kept by pruning. *G. citriodora* is a desirable variety. When watering Gardenias, care must be taken not to sprinkle them overhead, when in bloom, or the delicate white flowers will stain and turn brown. After flowering is past, the plants may be pruned to any desirable extent.

TECOMA.

The Tecomas are often mistaken for Bignonias by amateur gardeners. But the latter are usually furnished with tendrils, whilst the former have none. Tecomas are either climbers, semi-climbers, or tree-like shrubs. They have remarkably graceful foliage, and bear handsome flowers.

VARIETIES.

T. Velutina, *T. capensis*: These two flower more or less all the year round. *T. Smithii*: Flowers, orange-yellow. *T. mackeni*: This is a semi-climber, and may either be used as a shrub or climbing plant.

TRITOMA.

Tritoma uaria grandiflora (Queen's Lily): A handsome tribe of grass-tree-like foliage plants, producing fine spikes of crimson and orange flowers; most beautiful for a back border. The plant is also known as the "Red-Hot-Poker Plant."

VIBURNUM.

As ornamental foliage plants alone, these are well worthy of a place in the garden, but they are still more to be desired on account of their beautiful flowers.

VARIETIES.

V. lucidum: *V. macrocephalum* (the gigantic Gueldre Rose); *V. opulus* (Gueldre Rose, or Snowball Tree); *V. plicatum*: *V. Sieboldii*; *V. sinensis*, white; *V. suspensum* (height, 15 ft.); *V. tinus* (Laurestinus), one of the finest shrubs in cultivation, only suitable for the colder parts of the State.

TELOPEA (Waratah).

T. speciosissima: A gorgeous Australian native plant, producing magnificent large heads of brilliant crimson flowers.

SPIRÆA.

This genus contains the old familiar Meadow-Sweet of the English fields, besides several beautiful cultivated species. They are deciduous, free-blooming, and useful shrubs, which may be seen in many Queensland gardens.

VARIETIES.

Anthony Waterer: Free-flowering, crimson, one of the best; height, 1 ft.; California, pink, 2 ft. *S. corymbosa*: A small shrub of slender, twiggy growth, about 2 ft. high; very pretty when in full blossom, with its small white flowers, borne in crowded compact heads on the ends of the twigs. *S. rupestris*, white, 2 ft.; *S. grandiflora*; *S. Douglassi*; *S. caryopteris Mastocanthus* (called Blue Spiræa). This is not a true Spiræa, but a suitable companion to the crimson variety. It is a most beautiful, free-blooming plant, and can be cultivated in pots or out of doors. It begins to flower when only a few inches high. The flowers are of a lovely rich lavender-blue colour. It blooms right through the season.

CÆSALPINIA (Poinciana) GILLIESII (Bird of Paradise).

This beautiful, free-flowering shrub grows to a height of about 4 ft., and thrives well on the coast lands in the Southern part of the State, and also in the Northern interior as far as 400 miles west of Rockhampton. It has remarkably pretty, feathery, bi-pinnate foliage of minute leaflets, and bears large panicles of lovely flowers with pale yellow petals, from out of which proceed very long crimson stamens. It is apt to decay after two seasons, for which reason it is best to raise fresh plants every year from seed. When in seed, the seed-pods should be covered, before half-grown, with muslin, to protect them from the ravages of an insect which rarely fails otherwise to penetrate them and destroy the seed.

POINSETTIA PULCHERRIMA.

A very large, spreading shrub, 8 to 10 ft. high. During the cool season it bears little knobs of yellow, insignificant flowers of the size of a pea, surrounded by rays of large, elliptical, crimson-scarlet, bracteal leaves. It blossoms on the wood of the current year. No plant strikes more readily from cuttings, and it thrives in almost any soil.

PLUMERIA (Frangipanni).

This plant is something like a small tree about 10 ft. high, not ill-looking when in full foliage and bloom, but remarkably uncouth when the succulent, gouty-looking stems are destitute of leaves, as they are in the cold months. It bears, during the hot season, at the ends of the stems, large corymbs of large, pure white, exquisitely fragrant flowers, with the interior of the cup yellow. Propagated easily by cuttings. There is an interesting and very pretty variety of this shrub, the unexpanded flower-buds of which are of a deep dark crimson colour. The borders of its petals curl upwards, and are beautifully edged with crimson.

OCHNA.

Ochna multiflora is a free-flowering shrub, with bright-yellow flowers. The seed berries are very effective.

PITTOSPORUM.

All the Pittosporums are highly ornamental, and are suitable for single specimens in the shrubbery. Their chief merit as ornamental plants consists entirely in their neat, shining green, dense foliage.

VARIETIES.

P. eugenoides: This variety is suitable for ornamental, evergreen hedges, as are also *P. undulatum* and *P. eugenoides variegata*; *P. Tobira* and *P.T. variegata* are also desirable kinds.

PLUMBAGO.

A favourite family of free-flowering shrubs. *P. capensis* is a small, prostrate growing shrub, which bears a profusion of pale, azure-blue flowers of the same size and form as those of the Phlox. *P. capensis alba* is a splendid shrub, bearing white flowers in great profusion. Other varieties are—*P. Larpentæ*, which produces flowers of a much deeper blue, and *P. rosea*, which bears crowded racemes of moderate-sized, pale, pinkish-scarlet flowers.

LAGERSTROEMIA.

A splendid, hardy, deciduous, free-flowering shrub. The flowers are very handsome; pink, white, and dark mauve.

VARIETIES.

L. indica: An erect-growing shrub, 3 or 4 ft. high, bearing, in unbounded profusion, large panicles of rather small, fringe-petalled, rose-coloured flowers. There is one variety with pure white flowers, and another with lilac flowers. The three varieties grown together form a most lovely ornament to the garden. *L. elegans*: This shrub is a most magnificent object when in full flower, with its great compact panicles of light-purple blossoms.

Times of Sunrise and Sunset at Brisbane, 1909.

| DATE. | JANUARY. | | FEBRUARY. | | MARCH. | | APRIL. | | PHASES OF THE MOON. |
|-------|----------|-------|-----------|-------|--------|-------|--------|-------|------------------------------|
| | Rises. | Sets. | Rises. | Sets. | Rises. | Sets. | Rises. | Sets. | |
| 1 | 4:57 | 6:46 | 5:21 | 6:42 | 5:40 | 6:20 | 5:57 | 5:46 | |
| 2 | 4:57 | 6:46 | 5:22 | 6:41 | 5:41 | 6:19 | 5:58 | 5:45 | 7 Jan. ○ Full Moon 0 13 a.m. |
| 3 | 4:58 | 6:46 | 5:22 | 6:41 | 5:42 | 6:18 | 5:58 | 5:44 | 15 " ☽ Last Quarter 4 11 " |
| 4 | 4:59 | 6:46 | 5:23 | 6:40 | 5:42 | 6:17 | 5:59 | 5:43 | 22 " ● New Moon 10 12 " |
| 5 | 4:59 | 6:46 | 5:24 | 6:40 | 5:43 | 6:16 | 5:59 | 5:42 | 29 " ☾ First Quarter 1 7 " |
| 6 | 5:0 | 6:47 | 5:25 | 6:39 | 5:44 | 6:15 | 6:0 | 5:41 | |
| 7 | 5:1 | 6:47 | 5:25 | 6:38 | 5:44 | 6:14 | 6:0 | 5:40 | |
| 8 | 5:2 | 6:47 | 5:26 | 6:38 | 5:45 | 6:13 | 6:1 | 5:39 | |
| 9 | 5:2 | 6:47 | 5:27 | 6:37 | 5:45 | 6:12 | 6:1 | 5:38 | 5 Feb. ○ Full Moon 6 25 p.m. |
| 10 | 5:3 | 6:47 | 5:28 | 6:36 | 5:46 | 6:11 | 6:2 | 5:37 | 13 " ☽ Last Quarter 10 47 " |
| 11 | 5:4 | 6:47 | 5:28 | 6:36 | 5:46 | 6:10 | 6:2 | 5:35 | |
| 12 | 5:5 | 6:47 | 5:29 | 6:35 | 5:47 | 6:9 | 6:3 | 5:34 | 20 " ● New Moon 8 52 " |
| 13 | 5:5 | 6:47 | 5:30 | 6:34 | 5:48 | 6:7 | 6:3 | 5:33 | 27 " ☾ First Quarter 0 49 " |
| 14 | 5:6 | 6:47 | 5:30 | 6:33 | 5:48 | 6:6 | 6:4 | 5:32 | |
| 15 | 5:7 | 6:47 | 5:31 | 6:33 | 5:49 | 6:5 | 6:4 | 5:31 | |
| 16 | 5:8 | 6:47 | 5:32 | 6:32 | 5:49 | 6:4 | 6:5 | 5:30 | 7 Mar. ○ Full Moon 0 56 p.m. |
| 17 | 5:9 | 6:47 | 5:33 | 6:31 | 5:50 | 6:3 | 6:6 | 5:29 | 15 " ☽ Last Quarter 1 42 " |
| 18 | 5:9 | 6:47 | 5:33 | 6:30 | 5:50 | 6:2 | 6:6 | 5:29 | |
| 19 | 5:10 | 6:46 | 5:34 | 6:29 | 5:51 | 6:1 | 6:7 | 5:28 | 22 " ● New Moon 6 11 a.m. |
| 20 | 5:11 | 6:46 | 5:35 | 6:28 | 5:51 | 6:0 | 6:7 | 5:27 | 29 " ☾ First Quarter 2 49 " |
| 21 | 5:12 | 6:46 | 5:35 | 6:28 | 5:52 | 5:59 | 6:8 | 5:26 | |
| 22 | 5:12 | 6:46 | 5:36 | 6:27 | 5:52 | 5:57 | 6:8 | 5:25 | |
| 23 | 5:13 | 6:46 | 5:37 | 6:26 | 5:53 | 5:56 | 6:9 | 5:24 | |
| 24 | 5:14 | 6:45 | 5:37 | 6:25 | 5:53 | 5:55 | 6:9 | 5:23 | 6 Apr. ☾ Full Moon 6 28 a.m. |
| 25 | 5:15 | 6:45 | 5:38 | 6:24 | 5:54 | 5:54 | 6:10 | 5:22 | 14 " ☽ Last Quarter 0 30 " |
| 26 | 5:16 | 6:45 | 5:38 | 6:23 | 5:54 | 5:53 | 6:10 | 5:21 | |
| 27 | 5:17 | 6:44 | 5:39 | 6:22 | 5:55 | 5:52 | 6:11 | 5:20 | 20 " ● New Moon 2 51 p.m. |
| 28 | 5:17 | 6:44 | 5:40 | 6:21 | 5:55 | 5:51 | 6:12 | 5:19 | 27 " ☾ First Quarter 6 36 " |
| 29 | 5:18 | 6:43 | ... | ... | 5:56 | 5:50 | 6:12 | 5:18 | |
| 30 | 5:19 | 6:43 | ... | ... | 5:56 | 5:48 | 6:13 | 5:17 | |
| 31 | 5:20 | 6:42 | ... | ... | 5:57 | 5:47 | ... | ... | |

Tropical Industries.

CARAVONICA COTTON.

The cultivation of Caravonica cotton appears to be gaining ground in many parts of the world, and Dr. Thomatis, of "Caravonica," Cairns, is now making a world's tour in the interests of the company who have acquired the sole right to the operations in connection with his business. It was stated that the doctor's plantation at Cairns had passed into the company's hands, but this is not so, as he has placed a manager in charge during his absence in Egypt, India, and Europe, and will resume his work there on his return. The Cuban correspondent of the "Journal of Agriculture of Jamaica" informs its readers that in Monte Cristo, in the most easterly part of Cuba, 1,500 ft. above sea level, was last Autumn planted about 15 acres with Caravonica silk, and about 50 acres with Caravonica wool cotton. Although the planting could not be done till the first days of December, as the seeds ordered from Australasia did not come before that time, the result is most satisfactory for both varieties. The trees have borne and are still bearing very richly. Samples of the cotton have been sent to several experts in America and Europe, and from all quarters the cotton has been praised for strength, gloss, and length of staple. By this enterprise it seems to be proved that of all kinds of cotton, known up to date, the Caravonica is the best one for planting in Cuba, as it possesses a considerable power to resist drought, storm, and insect pests.

We have planted our trees at the distance of 7 x 7 ft.; but, according to our experience, we will recommend planting 8 x 8 ft., as even at this time—in the middle of September—most trees have grown to a height of 11 x 12 ft., some of them are still higher. We shall have to prune them rather severely for giving them more sunlight and facilitate the picking.

After all, the enterprise seems to be a very profitable business. A new area is cleared, and when planting the new acreage—which planting is to take place in September—we shall have the great advantage of using our own selected and acclimatised seed.

This is a very interesting result. Cuba is cooler than Jamaica, and at 1,500 ft. the elevation would be equal to our 2,000 ft.

DEMAND FOR SISAL FIBRE.

From an article in "Dalgety's Review," 1st February, on the sisal industry in Queensland, we take the following:—

"New industries often make slow progress for some years, though, ultimately, they forge their way to importance and success. The beaten tracks of work and trade are preferred to novel undertakings. Even the promise of large profits will hardly induce many to venture on untried occupations. Pioneers must be found to open them up, and, by their success, prove their worth, then others will follow. The sisal hemp industry in Queensland is passing through this initiatory stage. The demand for sisal fibre is always active. Large importations of rope and twine are always being made; it is estimated that there will be required for the wheat harvests of the Commonwealth this year 3,000 tons of binder twine, and the material for this could easily have been produced in Australia. Prices are good, sometimes reaching

almost £40 per ton. . . A fresh start needs to be made in this industry. Its value has been proved. Enthusiasts need not now paint it in glowing colours. It needs only the observant man to take it up for its real worth. It may not be generally known that the Commonwealth Government is offering a bonus of 10 per cent. on the market value of this product."

[The writer is slightly incorrect in stating that "no increase in the general acreage planted has recently been made. Since August last a large plantation has been in course of formation near Cairns, N.Q., by Mr. Thos. Mills, junr., who already has 50,000 plants growing; also in the South, near Brisbane, the Woolahra Park plantation has been gradually extended, until about 70 acres are now planted, and a considerable area is cleared and ready for planting when a good rainfall occurs. The St. Helena plantation has also been increased by several acres. The Central district plantation (Bajool), on the North Coast line, however, lately purchased by Mr. M. H. Moreton, is at present at a standstill. Mr. Jas. Cornwell has started a sisal plantation near Gladstone.—Ed., "Q.A.J."]

Mr. T. H. Wells, of Childers, has sent two consignments of plants—50,000 and 450,000 respectively—to Mombasa, in British East Africa.

SIBERIA.

Many people still think that the word "Siberia" is synonymous with Arctic desolation, and a place of horrible exile for Russian malefactors and political offenders. As a matter of fact, the greater portion of Siberia (the southern) consists of splendid country for cattle-raising and dairying.

Before 1893 Siberia produced no butter at all for exportation. In 1893 the first modern-arranged dairy for producing butter for export was started at Bezirk, near Kurgan, and in 1898 there were 140 dairy farms in Siberia, exporting about 50,000 cwt. butter. In 1902 the number of dairy farms reached 2,035, and the export of butter in that year reached the amount of 690,000 cwt. In 1903 the butter exports were given at 2,487,000 lb., equal to, say, 830,000 cwt., and for 1907 they were roughly calculated at 1,084,000 cwt.

Siberia has always been considered one of the most benighted countries in the world, but apparently it is losing its bad name, and could show Australia points in the way of attracting immigrants. During 1907 more than 500,000 persons voluntarily emigrated from European Russia. Every colonist arriving in Siberia receives 37 acres of land free, paying no taxes for the first three years, and only half the regular taxes for the next three.

WORMS IN PIGS.

To expel worms in pigs, the following may be used, with care, taken so that each animal gets a proper dose:—Santonine, powdered areca nut and calumba root, given in a little food after the pigs have been fasted for twelve hours. The following morning give each a dose of castor oil or Epsom salts, also on an empty stomach. The dose of santonine for a pig four months old is 5 gr., areca nut $\frac{1}{2}$ dr., calumba root $\frac{1}{2}$ dr., castor oil 1 oz., Epsom salts $\frac{1}{2}$ oz. Particular attention must be paid to the sanitary condition of sties, frequently swilling them down with boiling water and some disinfectant, such as Sanitas. The common bowel worms of pigs are taken into the system either with the food or water. All food, both liquid and solid, should, for a time at least, be boiled before being given, and the animals should not be allowed to drink at ditches or pools.

General Notes.

THE FIRST SHEEP IN AUSTRALIA.

It is difficult to imagine that little more than a century ago sheep breeding was an unknown pursuit in Australia. According to an interesting account of the early history of pastoral farming in Australia in the "Melbourne Argus," in the first return of live stock published in 1788 the total number of sheep in Australia was only twenty-nine, so that the pastoral pursuit which to-day is so prominent and important a feature in the welfare of Australia may be said to extend over only a single century. The first introductions of sheep were made from the Cape of Good Hope; and, as might be expected, the animals were of an inferior description, and gave such a poor account of themselves, that the conditions in Australia were officially described as unsuitable for sheep, and led to the opinion being formed that the stock breeding resources of the country would depend upon cattle.

WHAT NOT ADVERTISING COST HIM.

The "New York Farmer" relates a bit of history of a man who thought he would engage in the breeding of dairy cattle. So he bought an £800 bull and thirty cows at £60 each. After a time he had 100 fine heifers and bulls, and sat down waiting for the men who wanted nice stock (but couldn't tell where he lived or who he was) to come and buy his cattle. But they didn't come. He wouldn't advertise, so it was all money thrown away. He got discouraged and sold his 100 head to a shrewd buyer for £300. The purchaser engaged him to keep the stock till he could dispose of them, and set about at once advertising them, and the records and pedigrees of their ancestors. In a few weeks he had them all sold, at an average of £70 each, and went on his way rejoicing. Farmers everywhere seem to have a great aversion to advertising their live stock, seed grain, &c. But if they are going into the breeding of pure-bred stock of any kind they must seek their customers over a wide range of territory, for only here and there a man can be found who has the enterprise to want such stock.

COAL TAR FOR THE PUMPKIN BEETLE.

A correspondent of the "Australian Field" writes:—

"I saw some time ago an article in 'The Australian Field and Fruit Grower,' treating of the so-called ladybirds on pumpkin plants. Now, I was told something which induced me to try an experiment. I treated the pumpkin seed for two rows thus: I used a little coal tar in the same way that we used to dress the seed corn to prevent its being eaten by bandicoots (any old farmer knows how), with the result that those rows were never touched by the pumpkin beetle, while the rest were completely destroyed. I hope this information may be of service to growers."

[The seed maize was treated with coal tar by Queensland farmers, in order to prevent the seed being eaten by bandicoots, but this had nothing to do with rendering the leaves immune to possible attacks of insects. It is difficult to see how tarring the pumpkin seeds would prevent destruction of the leaves by the beetle. As the writer, however, says that he has proved it to have that effect, the experiment would be worth trying.—Ed., "Q.A.J."]

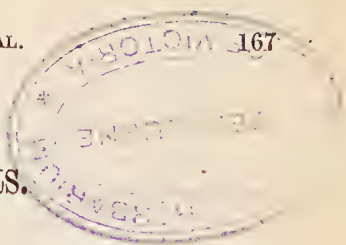

Answers to Correspondents.

WIRE FENCES.

NEW CHUM, Bell—

A wire fence is more suitable for your district than post and rail. It is more easily erected, requires far less timber, hence involves less cartage, is not so easily destroyed by bush fires, and is easy to repair. The mainstays of such a fence are the strainer posts. (See last month's Journal on reinforced concrete strainer posts.) These posts at all corners and angles should be at least 12 in. in diameter, and they, as well as all other posts, should be barked. Set the strainer posts 4 ft. in the ground, and support them by means of stays, two to each. The stays should be strong—about 6 in. in diameter, heeled on to a mortice in the post, and 12 to 14 ft. long. Let the lower end into the ground, and butt it against a stout 3-in. piece of hardwood, driven 18 in. into the ground. Put in strainer posts at every 4 chains in the fence, and the other posts about 10 to 12 ft. apart. For smooth wire you may bore holes through the posts, which should be about 6 ft. 6 in. long, 8 in. wide, and 4 in. thick; but for barbed wire it is easier to fasten the wire to the posts by strong galvanised-iron dogs as soon as it is tightly strained. There are various implements used for straining, the simplest being merely a fork of a tree with a hole to admit the wire. It will strain and even break any ordinary fencing wire. For stretching barbed wire there is a handy tool which any blacksmith can make. It consists of a stout piece of steel about 1 in. wide and $\frac{5}{8}$ in. thick. One end is forged after the fashion of a jemmy, but with claws like those on a carpenter's hammer. To stretch the wire, the claws are caught behind a barb in the wire, and the tool is plied round the post as shown in the accompanying illustration.

The cost of a wire fence depends upon the kind of wire used, the number of wires, the expense of carriage and labour, and the abundance or scarcity of timber for posts. Where the posts are 12 ft. apart, one or two droppers should be used to stiffen the fence.

To be perfectly sheep and lamb proof the fence should be at least 3 ft. 6 in. high above the surface of the ground, the lowest wire 6 in. from the ground, the next four wires 4 in. apart, the sixth 5 in. from the fifth, the seventh 6 in. from the one below it, and, if an eighth wire is used, it should be 9 in. above the seventh. This gives a height of 3 ft. 6 in. securely wired. The posts should be about 18 in. in the ground, and 4 ft. 8 in. above it. As a further safeguard for cattle, a ninth wire (barbed) may be placed 1 ft. apart from and above the eighth wire, making a total height of 4 ft. 6 in. Sheep and cattle wires may be from 10 to 12 gauge.

For cattle only, the lowest wire (barbed) may be 24 in. from the ground, the second 14 in. above the lowest, and the third 12 in. above that again (all barbed).

Neither of these fences is proof against pigs, as they will squeeze under or through very small spaces, between even barbed wire. The only wire fence of any use in this case is Mitchell's K fence.

AMOUNT OF BARBED WIRE REQUIRED.

For two lines 100 ft. in length, $12\frac{1}{2}$ lb.; for three lines, $18\frac{3}{16}$ lb. Thick-set barbed wire, barbs 3 in. apart, run 450 yds., or 1 cwt. per coil.

Plain wire, No. 6 gauge, weighs $28\frac{1}{2}$ lb. per 100 yds., about 502 lb. being required per mile. No. 8 gauge weighs 19.8 lb. per 100 yds., or 348 lb. per mile.

A No. 6 gauge 4-wire fence takes 17 cwt. 2 qr. 20 lb. per mile, and for 5 wires, 22 cwt. 0 qr. 11 lb.

A No. 8 gauge 4-wire fence takes 12 cwt. 1 qr. 4 lb. per mile, and for 5 wires 15 cwt. 1 qr. 12 lb.

Tying and repairing wire, 14, 16, and 18 gauge, runs from 2,322, 3,894 to 6,560 yds. per cwt.

Wire netting may be reckoned from 17 to 32 cwt. per mile, according to width and mesh.

At 9 ft. apart, 587 posts will be needed, and at 12 ft. 440.

CURES FOR WARTS ON POULTRY.

R. W., Yatala—

We have already published several cures for warts on fowls. *See Journal*: Vol. VI., Jan., 1900, p. 23, and March, 1900, p. 233; Vol. X., May, 1902, p. 355; Vol. XIII., December, 1903, p. 591; Vol. XX., June, 1908, p. 288.

ANALYSIS OF CARROTS.

MARKET GARDENER, South Brisbane—

Carrots are good food for all kinds of stock. The answer to your question as to the food value of the carrot is supplied by an English authority, and published in the "Australian Field" of 13th February, as follows:—

Carrots are said to be the only vegetable from which poison of some kind cannot be extracted. An English authority, in reply to a request for a statement of the composition of this useful root, says:—

The total percentage of food in carrots is as follows:—Total dry matter, 13 per cent.; crude albuminoids, $1\frac{1}{4}$ per cent.; oil, $\frac{1}{4}$ per cent.; carbohydrate, $9\frac{1}{2}$ per cent.; fibre, $1\frac{1}{2}$ per cent. The following is the digestible percentage:—True albuminoids, $\frac{1}{2}$ per cent.; oil, 1-10 per cent.; carbohydrate and fibre, 10 per cent. Carrots are a very good food for stock of all kinds, but they are particularly valuable for horses and milking cows. Pigs eat carrots ravenously, and thrive quite well on them, while they also have certain medicinal properties. Carrots require good cultivation, and will do well on land that was manured for a previous crop, provided the ground is clear. The red carrot is most commonly grown, but the Belgian white carrot is an excellent variety, which grows quickly, and is of good quality. It is not good practice to grow carrots on freshly manured land, as the roots are apt to become forked and ugly.

The Markets.

PRICES OF FRUIT—TURBOT-STREET MARKETS.

| Article. | JANUARY. | |
|--|----------------|--|
| | Prices. | |
| Apples (Hobart), per case ... | 4s. to 6s. | |
| Apples (Victorian), per case ... | 4s. 6d. to 5s. | |
| Apples (Local), per case ... | 3s. to 5s. | |
| Apples (Cooking), per case ... | 3s. to 4s. 6d. | |
| Apricots, per quarter-case ... | ... | |
| Bananas (Cavendish), per dozen ... | 1d. to 2d. | |
| Bananas (sugar), per dozen ... | 1d. to 1½d. | |
| Grapes (Choice), per lb. ... | 1d. to 2½d. | |
| Lemons (Italian), per case ... | 12s. to 16s. | |
| Lemons (Sydney), per case ... | 8s. to 9s. | |
| Mangoes, per case ... | 1s. 6d. to 2s. | |
| Nectarines, per case ... | ... | |
| Passion Fruit, per quarter-case ... | 1s. 6d. to 2s. | |
| Papaw Apples, per quarter-case ... | ... | |
| Peaches, per quarter-case ... | 2s. 6d. to 4s. | |
| Pears, per half-case ... | 5s. to 7s. | |
| Pineapples, best rough, per dozen ... | 8d. to 1s. | |
| Pineapples (Choice), smooth, per dozen ... | 1s. 9d. to 3s. | |
| Plums, per quarter-case ... | 3s. to 4s. | |
| Tomatoes, per quarter-case ... | 1s. 6d. to 2s. | |

SOUTHERN FRUIT MARKET.

| | |
|--|------------------|
| Apples (Local), eating, per case ... | 7s. to 15s. |
| Apples (Local) cooking, per case ... | 3s. to 6s. |
| Apricots (Tasmanian), per quarter-case ... | 2s. 6d. to 3s. |
| Apricots (Choice), per quarter-case ... | 4s. to 5s. |
| Bananas (Queensland), per bunch ... | 2s. to 5s. 6d. |
| Bananas (Queensland), per case ... | 12s. 6d. to 13s. |
| Cherries, per quarter-case ... | ... |
| Grapes (Queensland), Muscatels, per box ... | 5s. to 6s. |
| Lemons (Local), per gin case ... | 8s. to 16s. |
| Lemons (Italian), per half-case ... | 17s. to 18s. |
| Lemons (Italian), per double case ... | 25s. |
| Mandarins (Emperor), per case ... | 8s. to 10s. |
| Mandarins (medium), per case ... | 5s. to 6s. |
| Mangoes, per case ... | 2s. to 3s. |
| Nectarines, per half-case ... | 3s. to 6s. |
| Oranges (Choice), per case ... | 6s. to 8s. |
| Passion Fruit (Choice), per half-case ... | 2s. to 3s. |
| Peaches (Slipstones), per half-case ... | 3s. to 5s. 6d. |
| Pears (Choice), per case ... | 4s. to 7s. 6d. |
| Pineapples (Queensland), choice, Queen, per case ... | 5s. to 6s. |
| Pineapples (Queensland), Ripley Queen, per case ... | 3s. to 4s. 6d. |
| Pineapples (Queensland), choice common, per case ... | 3s. to 4s. |
| Plums, per half-case ... | 3s. to 4s. 6d. |
| Rock melons (Local), per case ... | 4s. to 5s. |
| Rock melons (Queensland), per gin case ... | 4s. to 5s. |
| Tomatoes (Local), per half-case ... | 2s. to 3s. |
| Water melons (Queensland), choice, per dozen ... | 10s. |
| Water melons, medium, per dozen ... | 6s. to 8s. |

PRICES OF FARM PRODUCE IN THE BRISBANE MARKETS FOR
FEBRUARY.

| Article. | | FEBRUARY. | |
|------------------------|-----|-----------|--------------------|
| | | Prices. | |
| Bacon, Pineapple ... | ... | lb. | 10d. to 11½d. |
| Barley, Malting ... | ... | " | ... |
| Bran ... | ... | ton | £5 to £6 |
| Butter, Factory ... | ... | lb. | 11d. |
| Chaff, Mixed ... | ... | ton | £5 10s. |
| Chaff, Oaten ... | ... | " | £4 15s. to £5 5s. |
| Chaff, Lucerne ... | ... | " | £5 to £7 |
| Chaff, Wheaten ... | ... | " | £3 to £4 |
| Cheese ... | ... | lb. | 6½d. to 7d. |
| Flour ... | ... | ton | £9 10s. |
| Hay, Oaten ... | ... | " | £6 to £6 10s. |
| Hay, Lucerne ... | ... | " | £4 10s. to £5 5s. |
| Honey ... | ... | lb. | 2d. to 2¼d. |
| Maize ... | ... | bush. | 4s. 4d. to 4s. 6d. |
| Oats ... | ... | " | 3s. 9d. to 4s. 3d. |
| Pollard ... | ... | ton | £6 to £6 5s |
| Potatoes ... | ... | " | £7 10s. to £8 |
| Potatoes, Sweet ... | ... | " | ... |
| Pumpkins ... | ... | " | ... |
| Wheat, Milling ... | ... | bush. | 3s. 9d. to 4s. |
| Wheat, Chick ... | ... | " | 3s. 9d. |
| Onions ... | ... | ton | £7 10s to £8 10s. |
| Hams ... | ... | lb. | 10d. to 1s. 1½d. |
| Eggs ... | ... | doz. | 11d. to 1s. 4d. |
| Fowls ... | ... | pair | 3s. to 3s. 6d. |
| Geese ... | ... | " | 5s. 6d. to 6s. |
| Ducks, English ... | ... | " | 2s. 6d. to 3s. 3d. |
| Ducks, Muscovy ... | ... | " | 3s. 6d. to 5s. |
| Turkeys (Hens) ... | ... | " | 6s. 6d. to 8s. |
| Turkeys (Gobblers) ... | ... | " | 7s. 6d. to 18s. |

ENOGGERA SALEYARDS.

| Animal. | | JANUARY. | |
|--------------------|-----|-----------------------|--------------|
| | | Prices. | |
| Bullocks ... | ... | £9 17s. 6d. to | £10 12s. 6d. |
| " (single) ... | ... | £11 | |
| Cows ... | ... | £7 15s. to £9 2s. 6d. | |
| " (single) ... | ... | £9 10s. | |
| Merino Wethers ... | ... | 17s. 3d. | |
| C.B. " ... | ... | 15s. 3d. | |
| Merino Ewes ... | ... | 13s. 9d. | |
| C.B. " ... | ... | 18s. | |
| Lambs ... | ... | 12s. 3d. | |

Orchard Notes for April.

By ALBERT H. BENSON, M.R.A.C.

THE SOUTHERN COAST DISTRICTS.

The gathering and marketing of citrus fruit, as well as of pines, bananas, custard apples, persimmons, &c., is the principal work of the month. In the Notes for March I drew attention to the necessity for keeping all pests in check, particularly those attacking the ripening fruit. As it is the height of folly to look after the orchard thoroughly during the growing period of the crop and then to neglect the crop when grown, every possible care must be taken to keep fruit fly, peach moth, black brand, or other pests that destroy or disfigure the fruit in check, and this can only be accomplished by combined and systematic action. Citrus fruit at this time of the year often carries badly, as the stem is tender, easily bruised, full of moisture, and, consequently, very liable to the attacks of the blue mould fungus, which causes specking. The loss from this cause can be lessened to a considerable extent by carefully attending to the following particulars:—

- 1st. Never allow mouldy fruit to hang on the trees or to lie about on the ground. It should be gathered and destroyed, so that the countless spores which are produced by the fungus shall not be distributed broadcast throughout the orchard, infesting many fruit, and only waiting for a favourable opportunity, such as an injury to the skin by an insect or otherwise, combined with favourable weather conditions (heat and moisture), to start into growth.
- 2nd. Handle the fruit carefully to prevent bruising. Cut the fruit, don't pull it, as pulling is apt to plug the fruit—that is to say, to either pull the stem out or injure the skin round the stem—and a fruit so injured will go mouldy.
- 3rd. Sweat or dry the fruit thoroughly; if the weather is humid, laying the fruit out in the sun on boards or slabs is a very good plan.
- 4th. After sweating, examine the fruit carefully, and cull out all bruised or punctured fruit, and only pack perfectly sound dry fruit. It is better for the loss to take place in the orchard than for the loss to take place in the case in transit.
- 5th. If the mould is very bad, try dipping the fruit for a few seconds in a 2 per cent. solution of formalin. This will kill the spores, and if the fruit is placed in the sun and dried quickly before packing there will not be much chance of its becoming reinfested.

Don't gather the fruit too green, especially such varieties as the Beauty of Glen Retreat Mandarins, as immature fruit spoils the sale of the good article.

If the orchard has not been cleaned up after the summer rains, do so now; and do any other odd jobs that may be required, such as mending fences, grubbing out dead or worthless trees, cleaning out drains, &c.

Strawberry planting may be continued, and where new orchards are to be planted continue to work the soil so as to get it into the best possible tilth.

THE TROPICAL COAST DISTRICTS.

Clean up the orchards after the rainy season. Look out for scale insects, and cyanide or spray for same when necessary.

Go over the trees carefully, and when there is dead wood or water sprouts remove them. If bark fungus is showing, paint the affected branches with the

sulphur and lime wash. Clean up bananas, pineapples, and other fruits, as after the end of the month it is probable that there will not be any great rainfall, so that it is advisable to keep the ground well cultivated and free from weeds, so as to retain in the soil the moisture required for the trees' use during the winter months. Keep bananas netted; destroy guavas wherever found.

THE SOUTHERN AND CENTRAL TABLELANDS.

If the orchards and vineyards have not already been cleaned up, do so. Cultivate or plough the orchard, so as to get the surface soil into good tilth, so that it can absorb and retain any rain that falls, as, even though the trees will simply be hardening off their summer's growth of wood, it is not advisable to let the ground dry out. When citrus fruits are grown, attend to them in the manner recommended for the Southern Coast Districts; and when grown in the dry parts, keep the land in a state of good cultivation. Should the trees require it, a light watering may be given. Do not irrigate vines; let them ripen off their wood.

Farm and Garden Notes for April.

FIELD.—The wheat land should now be ready for sowing the early wheats, and that which has not been prepared should be ploughed without delay, April, May, and June at latest being the months for sowing. The main potato crop, planted in February and March, will now be ready for a first or second hilling up. The last of the maize crop will now have been got in. Where cotton is grown, the pods will now be opening, and advantage should be taken of dry weather to get on with the picking as quickly as possible. Picking should not be begun until the night dew has evaporated nor during rain. Sorghum seed will be ripe. Tobacco also will be ripening, and either the leaves or the whole plant harvested. Lucerne may be sown, as the growth of weeds has now slackened off, but the ground must be thoroughly prepared and cleaned. Sow oats, barley, rye, wheat, mangolds, and Swede turnips. Plant out paspalum roots. Seed wheat of whatever variety soever should be dipped in a solution of sulphate of copper (bluestone) in the proportion of 1 lb. of sulphate to 24 gallons of water. The seed may also be treated with hot water by plunging it in a bag into hot water at 120 degrees Fahr. for a minute or two, and then into water heated to 135 degrees Fahr. Allow it to remain in this for ten minutes, moving it about all the time. Then plunge the seed into cold water and spread out to dry. This plan is useful in districts where bluestone may not be obtainable. Another safeguard against bunt, smut, black and red rust is to treat the seed with formalin at the rate of 1 lb. of formalin to 40 gallons of water. Schering's formalin costs about 2s. 10d. per lb., and is sold in bottles. It is colourless and poisonous, and should be kept where no children or persons ignorant of its nature can have a chance of obtaining it. To treat the seed, spread it on a wooden floor and sprinkle the solution over it, turning the grain over and over until the whole is thoroughly wetted. Then spread it out to dry, when it will be ready for sowing. Instead of sprinkling, dipping may be resorted to. A bushel or so of seed is placed in a bag and dipped in the solution. During five minutes the bag is plunged in and out, and then the seed is turned out to dry. Formalin is less injurious to the grain than bluestone, but, while the latter can be used over and over again, formalin becomes exhausted. It therefore follows that only the amount required for immediate

use for sprinkling should be prepared. Do not sow wheat too thickly. Half a bushel to the acre is sufficient—more on poor land and less on rich soils. On light sandy soil the wheat should be rolled. On sticky land it should only be rolled when the land is dry, otherwise it will cake, and must be harrowed again after rolling. When the wheat is 6 in. high go over it with light harrows. If the autumn and winter should prove mild and the wheat should lodge, it should be kept in check by feeding it off with sheep.

KITCHEN GARDEN.—Hoe continually among the crops to keep them clean, and have beds well dug and manured, as recommended last month, for transplanting the various vegetables now coming on. Thin out all crops which are overcrowded. Divide and plant out pot-herbs, giving a little water if required till established. Sow broad beans, peas, onions, radish, mustard and cress, and all vegetable seeds generally except cucumbers. Early celery should be earthed up in dry weather, taking care that no soil gets between the leaves. Transplant cauliflowers and cabbages, and keep on hand a supply of tobacco waste, preferably in the form of powder. A ring of this round the plants will effectually keep off slugs.

FLOWER GARDEN.—The operations this month will depend greatly on the weather. If wet, both planting and transplanting may be done at the same time. Camellias, gardenias, &c., may be removed with safety. Plant out all soft-wooded plants such as verbenas, petunias, penstemons, &c. Sow annuals, as carnations, pansy, mignonette, daisy, snapdragon, dianthus, stocks, candy-tuft, phlox, sweet peas, &c. Those already up must be pricked out into other beds or into their permanent positions. Growth just now will not be too luxuriant, and shrubs and creepers may be shortened back. Always dig the flower beds rough at first, then apply manure, dig it in, and after this get the soil into fine tilth. Land on which you wish to raise really fine flowers should have a dressing of bonedust lightly turned in. Wood ashes also form an excellent dressing for the garden soil. Prune out roses. These may be planted out now with perfect success. Take up dahlia roots, and plant bulbs as recommended for March.

Agriculture.

ROMA STATE FARM.

REPORT ON SILAGE CROPS—SPRING SOWINGS.

The effects on the different crops of the phenomenal hot weather experienced in the latter part of December and the early part of January have furnished some valuable data towards ascertaining the most suitable kinds to grow for fodder purposes where such conditions are likely to eventuate.

The following were the varieties grown and observations made:—

MAIZE.—Sown 11th September. Plants through in eight to ten days, and grew rapidly until about the second week in November, when a short, hot, dry spell ensued. Beneficial rains followed, to which the crop responded quickly.

The heat wave experienced later completely ruined the crop, affecting it in the same manner as if it had been subjected to frost, the leaves being completely dried out, and so brittle as to be broken off by the wind. The cutting for silage purposes took place during the second week in January, the yield being estimated to be about $3\frac{1}{2}$ tons to the acre. At this time the plants had become so dry as to necessitate the addition of water to the material as it was chaffed into the silo, in order to conserve properly. Not 1 per cent. of the plants showed signs of cobbing.

Another crop of maize, sown a month later on land which had been fallowed (worked) for the previous six months, gave no better results.

The benefit derived from sowing graded seed was one of the chief features of these experiments, three and a-half days being occupied in thinning out the first crop sown with ordinary grain, whilst no labour was expended in this manner on the second, which was grown from graded seed.

SORGHUMS (*Sorghum saccharatum*).—Sown 19th October. Fit for ensilage in about 11 weeks from sowing. This is rather a quick-growing variety. It was not visibly affected by hot weather, and produced a fair quantity of fodder and seed. Stalk fine and leafy. Yield, about 4 tons to the acre.

EARLY AMBER CANE.—Sown 19th October. Fit for silage purposes in about 10 weeks from sowing. This is perhaps the quickest-maturing variety grown here at present, and probably the most suitable, as it produces a heavy crop of fine fodder. Stalks thin and leafy. Grows quickly after cutting. Yield, about 5 tons to the acre. Was apparently unaffected by hot weather.

KAFIR CORN (Red and White).—Sown 19th October. Were fit for silage purposes in about 13 weeks from that date, and provided the heaviest yield of fodder, estimated at about 7 tons to the acre; showed very little distress during hot weather. The red variety is the most suitable one to grow, being much finer in the stalk, and producing more foliage than the white. The second growths of these are much heavier than those of any other previously mentioned crops.

PLANTERS' FRIEND.—Sown October. This is the slowest-maturing variety of sorghum grown, and is only now, 17 weeks from sowing, in fit condition for producing the best ensilage. This showed the effects of the hot weather more than any variety, being at a more susceptible stage, but when congenial conditions supervened it recovered wonderfully, and will yield when cut a much heavier crop of material than those mentioned. Though not as suitable for converting into dry fodder as *Sorghum saccharatum* or Early Amber Cane, it should prove more nutritious than either in the form of ensilage, on account of the heavy crop of seed it has set.

COWPEAS.—Sown 15th October. This crop for forage and other purposes is evidently one of the most suitable grown here at present, and has afforded heavy quantities of succulent vegetation under conditions which proved injurious to others. During the excessive hot weather, when all other crops were at a standstill, these plants grew rapidly, and the leaves did not even flag on the hottest day.

These have not yet been harvested, but the yield of green feed, which at present covers the ground in a solid mass to a depth of about 2 ft., is estimated at about 8 tons to the acre.

A sowing of this crop made last month for seed looks splendid.

It has been proved conclusively, both during this and last seasons, that cowpeas will grow on dirty ground, and eventually cover the area sown with them in such a manner as to prevent ordinary weeds from coming to maturity, and in this respect have proved very valuable in the eradication of couch grass here.

[The latter statement in the above report is well worth noting. A crop which will effect the eradication of couch grass must prove of great assistance to the farmer in many parts of the State. In the year 1903 we paid a visit to the old meatworks at Charleville, where Mr. Fesler, an enthusiastic market-gardener, cultivated 6 acres entirely by hand. He was very much handicapped by the luxuriant growth of couch grass. Any crop which would have helped him in the laborious work of forking it out would have been of great assistance to him.—Ed. "Q.A.J."]

WHEAT-GROWING ON THE COAST LANDS.

In the past wheat has been grown with success in various districts on the coast, as far north as Bundaberg, but for many years this branch of agriculture has been abandoned on the seaboard in favour of lucerne and other fodder crops, maize, potatoes, and fruit. There are certainly no great stretches of land suitable for wheat-growing in the coastal districts, such as can be found in the Darling Downs country and in the Maranoa districts and other inland regions as far west as Barcaldine and Longreach. The bulk of the alluvial lands and river flats will undoubtedly grow good crops of wheat; but wheat thus situated will be likely to suffer from floods, from excessive winter growth and consequent lodging, and from fungus diseases, especially rust. Hence it is obvious that such lands may be much more profitably employed in producing such crops as those above mentioned, particularly in connection with dairying and pig-breeding. On the other hand, for quite opposite reasons, the thin uplands, particularly those overlying at shallow depths, reefs of shale, ironstone, or sandstone are not and cannot profitably be made "wheat lands." Among these poorer soils, the very best for the purpose will be found in those overlying granitic rocks. All soils having at shallow depths a tenacious yellow and red streaked "spewey" subsoil may at a glance be rejected as worthless for the wheat plant. The question of the suitability of the subsoil for wheat, as for most other crops, may be easily determined by a simple operation: Sink a hole to a depth of 18 in. or 2 ft., or until the subsoil is well entered. If this hole remains partly filled with water after each rain, or until removed by evaporation, it will be a waste of labour and means to attempt to grow wheat in its vicinity.

Lying between the two extremes of good and bad land there are all along the coast of Southern Queensland areas of rolling, moderately fertile, brown and reddish loam and black soils which undoubtedly are capable, with suitable management, of great things in wheat-growing. Doubtless these lands would quickly break down under the perpetual wheat-cropping system.

so much in vogue on the Darling Downs wheat farms, and they would certainly not equal those lands in the average yield per acre; but the crop upon these easily worked soils would be made cheaper, or, rather, at a greater profit to the grower. Nearly all who have attempted wheat-growing along the coast have made the mistake of using low-lying alluvial lands, which much better suit the requirements of coarse-growing lucerne and maize than wheat.

Now, taking the class of coastal soils referred to above, it may be said that they are nearly always deficient in the element nitrogen and in organic matter in general. This is sufficiently explained by the abundant rains and fervid summer heats of the Queensland coast climate. The wheat-grower's efforts must, then, be in the direction of storing up and conserving in the soil, for the use of the future crop, these wanting yet most necessary ingredients. To this end the sod which covers the ground, and the droppings of animals which have grazed on it, will contribute in an important degree towards the support of the intended wheat crop. The land should be cleanly ploughed to the depth of about 5 in., the work being completed at least six weeks before the time of seeding. The second or principal plough follows the "skim coulter" plough, burying the sod to such a depth that it cannot sprout through, leaving a loose mellow surface over the field. Within a couple of weeks the land should receive a thorough harrowing, with subsequent workings by the scarifier to keep down the weeds and secure a good tilth. When the ground is ready it will be necessary to think of the most advantageous seeding time. This will naturally vary in different districts, but one thing is certain, and that is, that the early seeding time as practised on the Downs will not be advantageous. The great danger of early seeding in the coast districts of the State is likely to arise from the action of warm, wet, winter weather, inducing a too early rank growth of the wheat plant.

If the season holds warm and dropping, until, say, the middle of May, wheat-sowing should be deferred until that time, or even until the beginning of June. If, on the other hand, the autumn was cold, with scant rainfall, it would be well to sow as quickly as possible after the middle of April. Follow the sowing with harrowing sufficient to cover the seed, and roll afterwards always. That much neglected implement, the roller, is one of the most valuable of cultural implements. It does what no other implement can do. Besides consolidating and pressing the soil firmly about the seed, and pulverising lumps, it leaves the ground in the best possible condition for the passage of harvesting machinery. Of all farmers the wheat-grower can least afford to neglect its use. It is an undoubted fact that soil, however poor, with very few exceptions indeed, may, by draining, manuring, and those operations associated with high farming in general, be brought into a suitable condition for the production of good crops of wheat where the climate is not unfavourable.

EXHAUSTED SOILS.

In a publication issued last year by the Department of Agriculture and Stock, entitled "Elementary Lessons in Agriculture," there occurs in the 4th Lesson of the 2nd Book the following passage:—"In reality, there is no such thing as an exhausted soil. The plant food is there, but it is out of the reach of the roots of the plants, and requires to be brought up in some way or another to become available. Constant cropping has certainly removed the fertilising matter from the surface, and, such being the case, good crops cannot be produced, and, in this sense, the land is said to be exhausted." Now, the Bureau of Soils of the United States Department of Agriculture has put forth an entirely new theory on the subject of so-called exhausted soils. As a matter of fact the Bureau declares that a soil does not become

exhausted by constant cropping, that the mineral plant food is always there, being reproduced as fast as it is absorbed by the crops. The cause of the failure of the soil to produce good crops is the formation of some chemical poison when one kind of crop is being continually grown. This idea naturally causes one's mind to consider lucerne-sick and clover-sick soils as containing such poisonous elements. To obtain confirmation of the new theory, Professor Whitney made systematic experiments, of which the following is a summary:—

“In order to test the idea, and find out if we were safe in announcing such a fact as this, so revolutionary as regards our former ideas, the Bureau of Soils has had parties in all parts of the State equipped with the most sensible methods for making these determinations in the field. We have taken out of the soil its own moisture, and have actually found similar quantities of phosphates of potash, of nitrates, and of lime, in the sandy soils of our truck region, in the ‘worn out’ soils of Virginia, in the fertile limestone soils of Pennsylvania, and in the black prairie soils of the West.

“We then went into the question of how much plant food is necessary; how strong a concentration the solution must have to support a growth of plants, and I may tell you investigators are not able to say how small the amount of phosphoric acid or of potash in the solution must become, if other conditions be maintained perfectly, before the plant will suffer. Plants have an extraordinary power for absorbing material from solutions. Take the case of the seaweed, from which iodine is extracted. Sea water has so little iodine that, although we have an exceedingly delicate method for the detection of iodine, we cannot discover it, even if we concentrate the water to a very small part of the original bulk; but the seaweed can get it and store it up in its tissues from that very diluted solution.”

Other experiments were made, and all of them pointed to the same conclusion: The difference of yields between fertile and what was popularly regarded as “exhausted” soil was not due to a difference in the supply of available plant nutrients. The suspicion was born that the unproductiveness of so-called worn-out soils was due, not to the absence of anything necessary to the plant's growth, but to the presence of something deleterious to its growth.

Several experiments were begun to test this suspicion. It was found at the outset that young seedlings would grow better in pure water, containing no plant nutrients whatever, than in the extract of soil which, though unproductive, lacked in none of the nutrient substances. This result again forced the bureau back to the conclusion that the unproductivity of the soil was due to the presence of a poison. To determine whether the soil was poisoned, lampblack was mixed with soil extract and filtered off. Wheat seedlings planted in it then grew lustily, though in the same soil previously they had done nothing. Both their top and their root developments were improved astonishingly. The lampblack added no nutrient to the soil; its sole service was to disinfect.

That these poisons render the soil unproductive, or, to speak more accurately, prevent the full and healthy germination of a seed, the bureau found out, determined their qualities, and identified them. Tyrosin, which is a substance found in green manure, is the name of one of them, and cumarin that of another. It was found that pure water, when impregnated with tyrosin, even to the small degree of 50 parts to a million of water, killed wheat seedlings outright, and that they thrived in the ratio that the quantity of tyrosin was diminished.

The question whether the soil can be cleansed from these poisons in some other way than the use of fertilisers is answered by the American scientists in the affirmative. It can be met by a systematic rotation of crops, and this, they think, is the true remedy.

QUANTITY OF SEED POTATOES REQUIRED TO PLANT AN ACRE OF LAND.

Those farmers who have been planting potatoes year after year do not require to be told how many hundredweights or tons they require to plant a given area, but there are many taking up farming nowadays for the first time, and not being brought up to the business, have very little, if any, idea of the quantities of any kind of seed required per acre for field crops. To such amateur farmers the following advice by "Garden and Field" will be acceptable:—

"The quantity required to plant an acre of land with potatoes is, of course, regulated by the size of sets and the distance apart they are planted. There is a great difference of opinion as to the size of sets to use. Generally, when potato-growers are discussing the size of sets to use, if they are asked what weight the sets should be they don't seem to know what is meant. One man says he prefers a good big set, another man prefers a small set—neither man seems to know the weight of the sets he is advocating. It will perhaps be a guide to some growers to know that a potato as large as an egg weighs as much as the egg, and an ordinary hen egg weighs 2 oz. Some growers consider a potato as large as a hen's egg will make two sets—this would be 1 oz. for each set. With potatoes planted 2 ft. from row to row and 1 ft. apart in the rows, it would take 21,780 sets, and the sets weighing 1 oz. each it would take 12 cwt. 0 qr. 17 lb. 4 oz. of seed to plant an acre; this is about the distance apart generally adopted in small gardens. On the farm potatoes would require to be planted about 2 ft. 6 in. by 1 ft.—this would take 9 cwt. 2 qr. 25 lb. of seed; with 1-oz. sets at 2 ft. 6 in. by 1 ft. 3 in. it takes nearly 8 cwt. of seed. The size of sets is one of the most important things the farmer that has to buy his seed has to consider. Seed potatoes the size of hen eggs are the most economical to buy; each potato will make two sets, and each set will grow as good a plant as a whole potato the size of an egg."

DISC-HARROWING LUCERNE.

The farmers of the United States of America are perhaps the most consistent followers of the policy of loosening the top soil round lucerne at intervals in order to give it a fresh growth. At first it was done with the old-fashioned cutting implements, such as the common cultivator, but when the disc-harrow was invented the farmers saw in it a much more satisfactory implement for that purpose. Now, however, they have found an improved one of Australian origin, and have adapted it to their own implements. They weld a set of spikes to each disc of their harrows, so that the implement tears the ground instead of cutting it, and claim that the results are very much better than with the disc-harrows.

TO COMBAT THE COTTON BOLL-WORM.

The Under Secretary for Agriculture and Stock has received from Messrs. Hemingway and Co., of Marsh Gate, London, a communication on the subject of the destruction of the boll-worm, which is occasionally very troublesome in the cotton fields here, as in other cotton-growing countries. They recommend the use of "London Purple," which is already extensively used for the destruction of fruit pests; in fact, it has been employed for this purpose for the past thirty years in Australia and in the United States to fight the cotton boll-worm, with eminent success. According to the circulars sent, the preparation is not expensive, ranging from 5½d. to 7½d. per lb., according to the manner in which it is packed for export.

Dairying.

THE DAIRY HERD, QUEENSLAND AGRICULTURAL COLLEGE, GATTON.

RECORD OF COWS FOR MONTH OF FEBRUARY, 1909.

| Number. | Cow's Name. | Breed. | Date of Calving. | Total Milk. | Average Test, Per cent. | Commercial Butter. | Remarks. |
|---------|---------------|-------------------|------------------|-------------|-------------------------|--------------------|----------|
| | | | | Lb. | | Lb. | |
| 1 | College Lass | Ayrshire ... | 31 Jan., 1909 | 1,128 | 4.0 | 50.53 | |
| 2 | Whitefoot... | Holstein-Devon | 20 Oct., 1908 | 754 | 3.9 | 32.81 | |
| 3 | Glen ... | Grade Guernsey | 29 Jan., 1909 | 833 | 3.5 | 32.32 | |
| 4 | Gem ... | Grade Shorthorn | 13 Dec., 1908 | 658 | 4.3 | 31.73 | |
| 5 | Conceit ... | Ayrshire ... | 22 Dec. " | 663 | 4.0 | 29.50 | |
| 6 | Dot ... | Shorthorn ... | 12 Nov. " | 689 | 3.8 | 29.17 | |
| 7 | Nancy ... | Grade Shorthorn | 7 May " | 663 | 3.8 | 28.07 | |
| 8 | No. 112 ... | Grade Guernsey | 24 Nov. " | 672 | 3.7 | 27.66 | |
| 9 | Laura ... | Ayrshire ... | 16 Nov. " | 682 | 3.6 | 27.28 | |
| 10 | Lady Ring | Guernsey ... | 26 Jan., 1909 | 552 | 4.4 | 27.26 | |
| 11 | Careless ... | Jersey ... | 1 Nov., 1908 | 573 | 4.2 | 27.23 | |
| 12 | Poppy ... | Grade Guernsey | 10 Jan., 1909 | 721 | 3.4 | 27.13 | |
| 13 | Len ... | Ayrshire ... | 6 May, 1908 | 656 | 3.7 | 26.99 | |
| 14 | Dora ... | Shorthorn ... | 18 Nov. " | 618 | 3.9 | 26.88 | |
| 15 | Maud II. ... | " ... | 16 Jan., 1909 | 577 | 4.0 | 25.78 | |
| 16 | Graceful ... | Grade Shorthorn | 10 Dec., 1908 | 469 | 4.8 | 25.36 | |
| 17 | Blackbird ... | Grade Holstein... | 4 Feb., 1909 | 732 | 3.0 | 24.09 | |
| 18 | Daisy ... | Holstein ... | 24 Oct., 1908 | 720 | 3.0 | 23.70 | |
| 19 | Friz ... | Shorthorn ... | 4 Feb., 1909 | 649 | 3.3 | 23.65 | |
| 20 | Eve ... | Jersey ... | 16 Oct., 1908 | 525 | 4.0 | 23.46 | |
| 21 | Nell ... | Shorthorn ... | 10 Feb., 1909 | 452 | 4.6 | 23.38 | |
| 22 | Comet ... | Holstein .. | 22 Nov., 1908 | 584 | 3.6 | 23.36 | |
| 23 | No. 1 ... | Shorthorn | 1 Nov. " | 615 | 3.4 | 23.13 | |
| 24 | Grace ... | Grade Shorthorn | 30 May " | 534 | 3.3 | 23.11 | |
| 25 | Lowla ... | Ayrshire... | 8 Dec. " | 606 | 3.4 | 22.80 | |
| 26 | Peewee ... | Grade Holstein .. | 20 May " | 500 | 4.0 | 22.35 | |
| 27 | Carrie ... | Jersey ... | 4 April " | 417 | 4.6 | 21.57 | |
| 28 | Ethel ... | Holstein ... | 3 Sept. " | 519 | 3.7 | 21.36 | |
| 29 | Wonder ... | Grade Shorthorn | 2 Dec. " | 548 | 3.4 | 20.62 | |
| 30 | Nita ... | " " | 23 Nov. " | 525 | 3.5 | 20.37 | |

The herd was fed from the 13th to 27th with green maize (chaffed) at the rate of 30 lb. per cow daily, and allowed to graze on the natural grasses.

MANURING FOR MILK.

A unique and valuable experiment in Taranaki, New Zealand, has been carried out with a view to determining in how far, if at all, the milk yield is affected by judicious top-dressing of pasture land.

The experiment was designed by J. Montgomerie Hatterick, F.H.A.S., N.D.A., of Sydney, N.S.W., and carried out by H. G. Sergel, of Eltham. The "New Zealand Farmer," of July, 1908, gives a full account of the experiment, and publishes the complete returns for the whole period of twelve weeks in tabular form, which we here summarise. The article has just reached us in pamphlet form, and affords most instructive reading. Mr. Hatterick says:—

The rapid development of the practice of top-dressing pasture lands in New Zealand has been quite an outstanding feature in the agricultural progress of the Dominion during the last five years, and particularly has this been

the case in the Auckland Province. There, more than anywhere else, does the soil respond to manures, and many numerous instances are cited of the phenomenal increases which have been brought about in the stock-carrying capacity of land and in the quantities of milk produced simply by judicious manuring. So obvious, in fact, are the resulting benefits that no special proof is needful to convince the average Waikato farmer of the value of top-dressing.

This is not, however, the case in other districts, and particularly in Taranaki, where the farmers have been slow to adopt an innovation without convincing proof of its advisability. The soils of Taranaki are in general rich; most of the province was covered with heavy bush so recently as twenty years ago; and so fertile is the land naturally that when the bush was cleared, and "a good burn" secured, no difficulty was experienced in establishing splendid pastures on the cleared lands. The climate of Taranaki is specially favourable to the growth of grass, and at first sight any artificial aid would appear superfluous, so luxuriant is the herbage in favourable seasons. This very fact has also contributed to prevent the rapid extension of the practice of top-dressing, because where grass is everywhere abundant it is difficult to detect any marked improvement of the manured area by inspection alone.

As will be shown later, however,

Grass is not always Feed,

and a pasture may be innutritious, although grass is abundant.

The object of the experiment, with which the present report deals, was to determine in how far, if at all, the milk yield was affected by judicious top-dressing. That the quality of the food has a most powerful influence upon the milk yield of dairy cattle has already been abundantly proved by numerous reliable experiments in the house-feeding of milch cows. That judicious manuring also had a great effect upon the quality of the feed in pastures is accepted by most intelligent practical men, but up to now there has been, so far as the writer is aware, no experimental proof of the fact, and the experiment is, therefore, absolutely unique and worthy of quite special study by all who take an interest in our agricultural progress.

The object of the experiment being to determine in how far the milk yield was effected by the manurial treatment of the pasture, it was necessary to compare for a fairly long period the yields of milk from equal areas of land, manured and unmanured. For this purpose, a block of fairly uniform land of first-class quality (its present value is about £33 per acre) was selected in a conveniently situated paddock, and two plots, each 4 acres in area, carefully measured off side by side. In July, 1907, the following mixture was applied to plot 1:—

1 cwt. 30 per cent. potash manure and
3 cwt. basic slag per acre.

No special precautions were taken to prevent stock from grazing over both plots throughout the early spring; and it was only on 8th October that the plots were fenced off and stock excluded. A week later (on 15th October) four cows of the ordinary type met with in Taranaki, but known to be of specially quiet temperament, were selected from the herd, and of these two were placed on each plot. The cows were known to be, when treated alike, all about equal in milk-yielding power. Commencing on 15th October, the milk of each cow was carefully weighed morning and evening for six weeks. At the end of that period the cows were interchanged, so that those which had been on the manured land were then transferred to the unmanured land, and *vice versa*. The yields were then recorded in the same manner as before for a further period of six weeks. By interchanging the cows in this manner, it was hoped to eliminate any difference which might be due to the individuality of one or other of the two lots of cows.

In considering these returns, it is important to note that, as Mr. Sergel reports, the area assumed as sufficient to graze two cows—namely, 4 acres—had been very much overestimated, and consequently the grass in both plots gained on the cows very rapidly, so much so that the manured portion had the appearance of a hay field. The striking superiority of the manured plot is, therefore, all the more significant, in view of the fact that both lots of cows had apparently throughout a superabundance of feed.

Bearing this fact carefully in mind, it is seen from the complete table of results that the net total increase was 258½ lb. of milk from 4 acres of land in twelve weeks, equivalent to 64½ lb. of milk per acre in twelve weeks.

Assuming that the ratio of manured to unmanured would have remained the same throughout a milking season of thirty-eight weeks, as it was during the twelve weeks recorded, the difference would be, in round numbers, 204 lb. increased yield of milk per acre—*i.e.*, practically 20½ gallons. This at the price actually paid by the factory to which the milk was sent—*viz.*, 4½d. per gallon (which is calculated from the average butter-fat content of milk from the whole herd on Mr. Sergel's farm, and the price paid by the factory for the same)—represents an increased monetary return of 7s. per acre in the first season. The manures cost on the farm 24s. per acre, and as there is no doubt that the heavy dressing given will remain effective for four or, perhaps, five years, it is permissible to spread the cost over four years at any rate, in which case we have already a profit of 1s. per acre in the first year.

This, however, by no means represents the actual gain, or the increase which would be obtained in ordinary practice. In all the "Manuring for Mutton" experiments which have been carried out during the past ten years, it has been usual to stock each plot to its full carrying capacity. This was not done in the present trial, and Mr. Sergel estimated that the manured plot would easily have carried one cow more than the unmanured, and it is intended in future work to adopt the plan of putting on each plot as many cows as it will carry.

Meantime, a better idea of the value of top-dressing with potash and slag may be formed if the yields from the cows on the manured land be compared with those from the animals on the unmanured portion, in order to arrive at the average daily gain per cow from top-dressing. Calculation from the table of complete returns shows:—

| | | | |
|---|-----|----------|---|
| (a) Average daily yield per cow on manured land | ... | 43'5 lb. | * |
| (b) Do., unmanured land | ... | 41'9 " | |
| Average daily increase per cow | ... | 1'6 " | |

If we assume, as before, that the ratio of manured to unmanured would remain throughout a milking season of thirty-eight weeks, and the evidence of the figures goes to show that this is within the mark, because there is a decidedly quicker falling off in the cows on the unmanured land towards the end of the test, we now find that this increase amounts to 42'5 gallons per cow for the season. This quantity at the same price as before (4½d. per gallon) is worth 14s. 6d., which sum represents the increased earnings per cow for the season. So much for the actual financial results.

One or two points in the table of figures are of interest. Firstly, it will be noticed, on comparing the weekly returns, that after the fourth week the cows on the unmanured plot fall off very rapidly, while those on the other plot keep up the quantity until the end of their stay there.

Secondly, the rapid response of cows Nos. 3 and 4, when transferred from unmanured to manured land. In their last week on the unmanured land cows Nos. 3 and 4 gave 50 lb. of milk less than cows Nos. 1 and 2, whereas after they had been six weeks on the manured land, they were giving 30 lb. milk

Plate XXV.

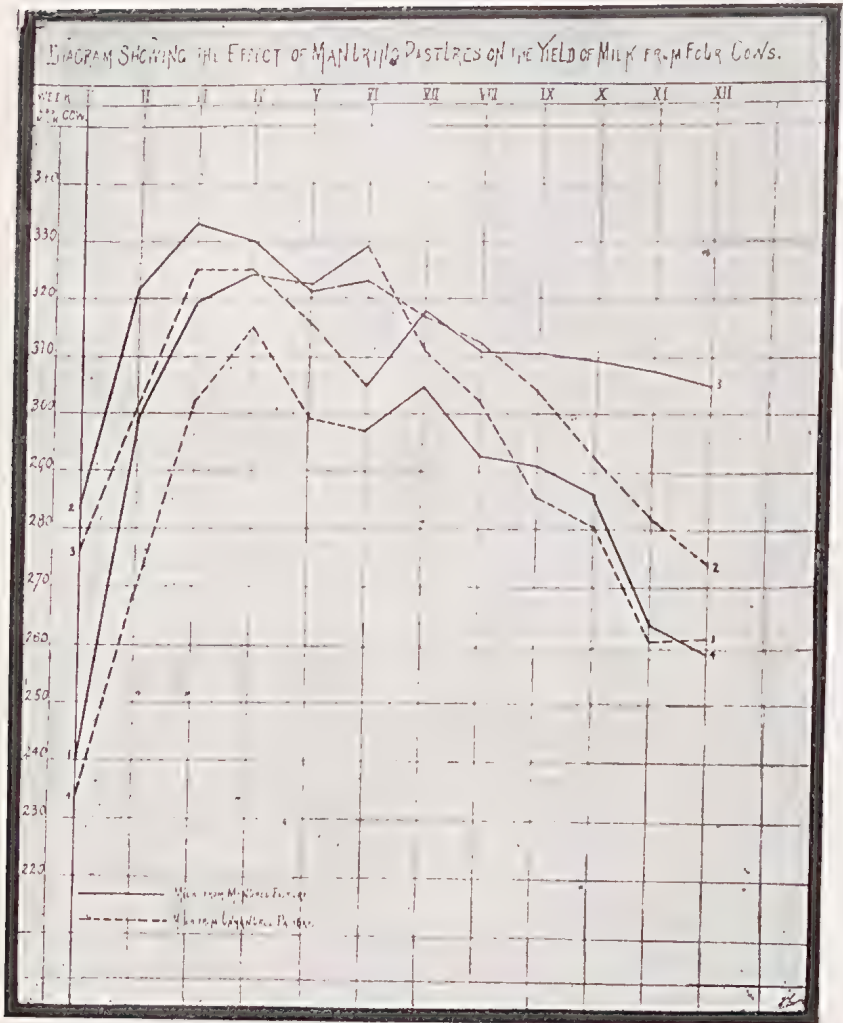

more than Nos. 1 and 2. It is important to mention that No. 4 was towards the end of the experiment unwell, otherwise the difference in the yields would have been greater. The tables show that No. 4 commenced to fall off about the beginning of the fifth week of the trial, and from that point onwards fell off steadily until the twelfth week, in spite of her transference at the end of the sixth week to the nutritive manured ground.

If No. 3 alone be compared with Nos. 1 and 2, it will be seen that whereas, at the end of the first six weeks she was giving 34 lb. of milk less than Nos. 1 and 2 respectively, on the manured ground, after a lapse of six weeks, she was giving 8 lb. and 6 lb. more than Nos. 1 and 2 respectively.

At the end of twelve weeks Mr. Sergel, on his own initiative, made an attempt to investigate the effects of the manuring upon the butter-fat content of the milk from manured *v.* unmanured grass, and he has reported on this test as follows:—

“A further experiment was carried for six days longer, to ascertain what difference there might be in butter-fat between grazing in the two paddocks, the cows being changed on the third day. It was found on the third day Nos. 3 and 4 on the manured piece gave 3'00 lb. of butter-fat, and Nos. 1 and 2, on the unmanured, gave 2'45 lb. of butter-fat, a difference of '55 lb. At the end of the second period Nos. 3 and 4 on the unmanured gave 2'73 lb., and the others 2'52 lb., a difference of '21 lb., or a net difference of '33 lb. I may say that at the end of the first period Nos. 1 and 2 gave 5 lb. weight of milk less than Nos. 3 and 4; and at the end of the second period, after being on the manured ground, gave 5 lb. of milk more, a difference of 10 lb. in three days.” (Note.—The quantities of butter-fat were determined from the creamery test of a composite sample of the milk from both cows on each plot, and the actual butter-fat produced per diem by the two cows calculated from the quantity of milk produced and the percentage of butter-fat it contained.)

This superiority in butter-fat of milk from cows grazed on top-dressed land is alone sufficient to warrant the expenditure, and forms one of the most favourable arguments in favour of top-dressing.

In conclusion, when one considers the fact that the experiment was conducted in one of the best dairying districts of Taranaki, on land which grows in an ordinary season abundance of grass, with ordinary cows not specially selected, and finally, but most important, that the number of cows was insufficient to keep down the grass on the plots, and that the manured plot could easily have carried one, and at times two, cows more, one realises what a convincing proof of the value of top-dressing this experiment affords.

It was quality of feed alone which produced the difference in favour of the manures, and if the extra quantity of feed produced has been fully utilised the profits would have been enormous.

The application of the mixture used in this experiment, namely—1 cwt. 30 per cent. potash manure and 3 cwt. basic slag per acre—cannot be too strongly recommended. The potash originally present in the lands on which dairying is practised soon becomes exhausted, and must be replaced, as it is essential to the growth of clover and grasses, but particularly the former, while phosphates, always more or less deficient, are supplied in the slag.

The proper time to apply the mixture is June or July, the earlier the better, but good results will attend the application any time from March to September.

The diagram shows more clearly than the tabulated return the superiority of cows Nos. 1 and 2 while on the manured land during the first six weeks of the trial. Cow No. 3, it will be observed from the yields during the first three weeks, is a better cow than No. 1; but after that time the effects of the feeding on cow No. 1 make themselves felt, and from that time until the end of the sixth week both cows on the manured land are superior to the other pair on

the unmanured land. The sudden falling-off in yield of all cows between the fourth and fifth weeks is due to the fact that at this time the period of oestrus occurred with all of them. From the sixth week, at which time the cows were interchanged, until the eighth, the unmanured land is slightly superior to the manured; but the effects of the change from poor to rich feeding, and *vice versa*, are very marked between weeks six and seven. From week eight until the end of the experiment the cows on manured land are again in the lead, and but for the fact that cow No. 4, which throughout gave by far the lowest yield, was during the last four weeks of the trial very unwell, the superiority of the manured land would have been still more marked.

MILK YIELDS.

The milk yields recorded for morning and evening for the first period of six weeks from the manured plot were:—1st week, 523 lb.; 2nd week, 621 lb.; 3rd week, 652½ lb.; 4th week, 654½ lb.; 5th week, 643½ lb.; 6th week, 652 lb.

Cows grazed on the unmanured pasture land yielded:—1st week, 509 lb.; 2nd week, 570 lb.; 3rd week, 626½ lb.; 4th week, 640 lb.; 5th week, 615½ lb.; 6th week, 602 lb.

These results show an increase in milk yield from the manured plot per week of 14 lb., 51 lb., 26 lb., 14½ lb., 28 lb., 50 lb. respectively, or a total of 183½ lb. for the first period of six weeks.

The second period shows a gain from the manured plot of 75 lb. over the yield from the unmanured pasture, the total gain from the manured plots for the whole period of twelve weeks was 258½ lb.

FEED AND THE RICHNESS OF MILK.

Many dairymen hold fast to the belief that the richness of milk is increased by certain foodstuffs. That this is not so has been demonstrated by frequent experiments. Much may be done to influence the quantity of milk that any certain cow will give, but very little effect on the richness of it can be obtained by varying the feeding. The "British Live Stock Journal" says, on this point:—The question has often arisen as to whether or not feeding meal will cause a cow to give milk with a larger percentage of butter fat. Once we heard one of the best known dairy farmers state that the feeding of meal would cause a cow to give richer milk; yet the general trend of experimental work shows that meal has little or no effect upon the percentage of fat in milk, but does tend to increase the flow or quantity of milk, especially where cows are not being fed to their capacity. There are a few apparent exceptions to the rule, but they only serve to emphasise the law that cows govern the quality or percentage of fat in milk, and feed and cow govern the quantity.

SEED ONIONS.

A method of treating large onions intended for seeding purposes is, to us, a novel one, but is recommended by a contributor to the "Gardeners' Chronicle." About midwinter select your bulbs, and plant them in pots, the smallest pots possible; those having a diameter of 5 in. or 6 in. will generally suffice. Three parts of each bulb should be left uncovered, using only just sufficient soil for the bulbs to root into. Place them in a cool house or cold frame; keep them moderately dry, and do not allow the young growth to become drawn. Plant the bulbs out in an open, sunny, position, early in the spring, and afford them a slight protection against frosts and cold winds until the weather is warmer. The bulbs should be planted three-parts their depth.

Poultry.

TO CURE BROODINESS IN HENS.

A correspondent lately writes that she had tried various means to overcome the desire of hens to sit, but with very little effect. We suggested a trial of the swinging coop, which, with us, answered the purpose to perfection. The suggestion was adopted, and now the lady has no further trouble. The coop is about 2 ft. square and 2 ft. high. The sides are made of thin battens

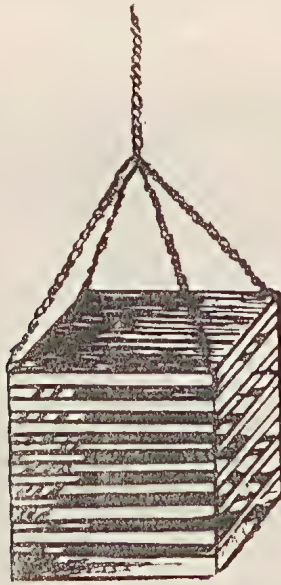

about 2 in. apart, so that the enclosed hen enjoys no peaceful privacy, and as the other fowls are fed close to the hanging coop, the noise and disturbance, combined with the constant swaying of her prison house, soon dispel all desire on the part of the hen to sit. The coop should be swung by a cord from a beam in the yard or poultry house, the yard for preference.

HONEY PASTE FOR LABELS.

It frequently happens that small labels on tins fail to adhere when dry. To completely overcome the difficulty, an American bee-keeper, who tried all kinds of paste for sticking labels on tin cans and buckets, conceived the idea of mixing honey with the paste, and this proved a perfect success, the labels sticking tightly to the cans after drying. To make the paste, mix dextrine and vinegar to the consistency to suit, then add about 2 oz. of honey to the pint of paste. Don't make the mistake of putting too much honey in, or the labels will have a greasy appearance, and will not dry right. It requires more honey in a dry atmosphere than in a wet one. Such paste will keep in either a warm or cold climate. Other pastes might do if a label is used which will go clear around the tin and overlap a little, but they will not hold a small label.

The Orchard.

AN ENORMOUS GRAPE VINE.

The Year-Book of the United States Department of Agriculture for 1894 states that there is now standing in California a vine which is considered the largest in the world. It was planted in 1842 by a Spanish woman. Beneath its spreading branches, which cover nearly half an acre, 800 persons could find protection from the sun's heat. The first election in Santa Barbara County, under American rule, was held beneath its ripening fruit. The vine is of the Mission variety. In 1893 it bore 8 tons of grapes, and in 1895 over 10 tons. The trunk of this vine is 7 ft. 8 in. in circumference. The celebrated vine in the conservatory at Hampton Court, England, planted in 1769, had, in 1830, a stem 13 in. in girth, and a principal branch 114 ft. in length, the whole vine occupying more than 160 sq. yds. In one year it produced 2,200 bunches of fruit, weighing, on an average, 1 lb.—in all, about 1 ton of fruit.

It is difficult to accurately estimate the age of vines by the usual method of counting the rings, because the yearly growth is not distinctly marked. Some maintain that the vine equals, and even surpasses, the oak in point of longevity. Even in America it has been impossible to ascertain the age that planted vines will attain, and the time that has elapsed since its discovery would not be sufficient had the experiment been begun when Columbus landed in 1492.

Pliny mentions a vine 600 years old. Miller tells us that some of the vineyards of Italy held good for 300 years, and that vines 100 years old were accounted as young. It was recently stated that there are still vines growing which were planted by the poet Horace on his farm. Some of the vines of Burgundy, Professor Bosc says, are more than 400 years old, and doubtless there are native American vines of much greater age. The writer of the article on the grape vine and its fruit in the Year-Book mentioned says that he never saw a vine amongst the endless numbers of natives that abound in the American forests that died from the effects of age.

ENDURANCE OF PONIES.

In 1859 (says the "Live Stock Journal"), when there was no railway line in America west of the Missouri River, a "pony express" for the carriage of letters was organised between St. Joseph, the railway terminus, and San Francisco, a distance of 2,000 miles. The country to be traversed was full of marauding Indians, so the express riders were small and active men, picked for their courage as well as for horsemanship and horsemastery. Five hundred ponies, bronchos, Indian, and "cayeuse," and eighty men, who had passed a riding test by travelling 100 miles at a stretch, were engaged. Each rider had from six to ten remounts, each awaiting him at appointed stages, and he rode from 60 to 80 miles a day—or night—as the nature of the country allowed. When the Indians were on the warpath the express travelled at night; Indian superstitions forbidding the braves to venture abroad in the dark, night travel was safe in the most disturbed districts.

"Buffalo Bill" was one of these express riders. He once rode 384 miles without rest or stop, except a halt of two minutes when changing ponies, which he did thirty-six times on the journey; he made the journey at an average pace of 16 miles an hour. Another rider named Haslam rode 264 miles at a stretch with only seven changes; one carried him 75 miles. Another rider named Moore rode 280 miles in 22 hours. How many ponies he used is not recorded.

Plate XXVI.



LARGEST GRAPE VINE IN THE WORLD.

Botany.

CONTRIBUTIONS TO THE FLORA OF QUEENSLAND.

By F. MANSON BAILEY, F.L.S., Colonial Botanist.

Order SOLANACEÆ. (THE NIGHTSHADE FAMILY.)

TRIBE ATROPEÆ.

Lycium afrum, *Linn.* The Caffir-thorn or African Boxthorn. A fiercely spiny shrub often utilised for hedges, but in some localities it has become quite a pest both in the pasture and cultivation paddock. The shrub is almost ever-green, attains a height of 5 to 6 ft.; leaves usually in clusters, linear-spathulate from $\frac{1}{2}$ in. to more than 1 in. long, fleshy, somewhat hoary. Flowers almost axillary, drooping; calyx glabrous except the margin, rather large, bell-shaped, 5-toothed at length 2 or 3 fid. Corolla funnel-shaped or nearly bell-shaped,

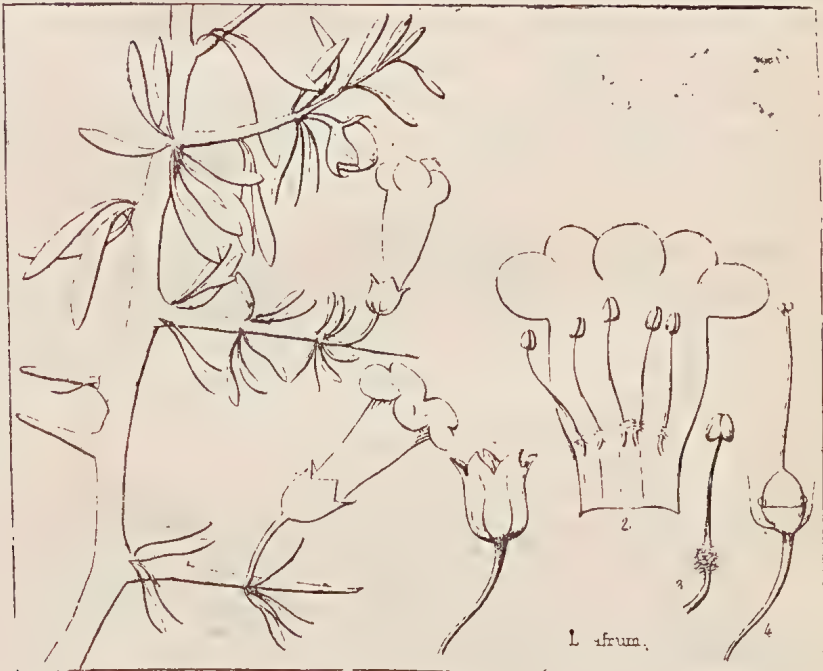

Lycium afrum.

lobes 5, rounded, short and reflexed; dark-coloured. Stamens 5, hairy at or near the base, not longer than the tube. Style slightly longer than the stamens; stigma shortly 2-lobed. Berry globose, violaceous.

The genus contains about 70 species, natives of warm regions. Birds and other animals eat the berries, and by this means the plant is spread far and wide over the land, to the detriment of those of a more desirable character.

The above diagram is from Miers' Illustrations, ii.

Horticulture

FLOWER GARDENING, No. 15.

PLANTS SUITABLE FOR IN AND OUT DOOR CULTURE.

By THE EDITOR.

ORNAMENTAL SHRUBS AND SHRUB-LIKE PLANTS.

EUPHORBIA (Crown of Thorns).

A curious and beautiful family of thorny plants, of dwarf habit, bearing trusses of vermilion flowers. Amongst the best are:—*Eu. jacquiniflora*, a small shrub which, in blossom, is one of the most brilliantly beautiful pot-plants of the garden. It is a useful winter-flowering plant of easy culture, thriving in a compost of rich loam and peat, made porous by sharp sand and bone-dust. It produces a profusion of small, dazzling, vermilion flowers, from the extremity of, and all down its long, smooth, slender, twig-like stems. If, some time before blossoming, its stem be bent, and fastened down over the rim of the pot, young shoots will break forth, and enhance the beauty of the plant by the additional flowers they produce. After flowering, the stems may be cut in, and the cuttings, if put in a pot of sand, will take root in a short time. *Eu. Bojeri* is a cactus-like plant, always in blossoms. It thrives best in a mixture of brick rubbish, leaf mould, and charcoal. *Eu. splendens* and *Eu. heterophylla* are also very beautiful.

CLERODENDRON.

A genus which comprises some of the most beautiful plants with which our gardens are adorned. Nothing can possibly surpass the loveliness of some of the species. Some occasionally yield seed, and all may be propagated without difficulty by cuttings, or from offsets or suckers, which most species send up abundantly. Flowers are produced from the top of the season's shoots, therefore, cut away wood of the previous season to within two or three buds of the base. To grow them well, much heat and moisture are necessary, but they do well in a lower temperature in winter.

VARIETIES.

C. fragrans: Flowers very double, like little roses; white, tinged with pink, of exquisitely delicate fragrance, borne in large compact heads. In favourable situations it does well out of doors. *C. odoratum*: Flowers of a pretty pale-blue, sweet scented. *C. Thomsonii* is a most beautiful climbing plant, which bears large corymbs of flowers, with white calyx and corolla with purple tube, and deep-crimson limb, succeeded by purple berries of the size of a pea.

BAUHINIA.

All the Bauhinias are remarkable for the peculiar form of their leaves, which are composed of two oval leaflets, laid side by side, and having their edges near the base united. In consequence of this twin-like union, the genus has been fancifully named after the two brothers Bauhin. They all bear seed, from which they are easily propagated.

VARIETIES:

There is a very extensive variety of this genus of shrubs and trees, a few of which can only be noted.

B. purpurea: A large, stout tree, effective in any garden large enough to display its handsome foliage and large, deep, rose-coloured flowers. *B.*

triandra bears large white flowers, as does *B. alba*. *B.* (so-called) *scandens* is a very beautiful variety, of wide-spreading habit. It bears a vast profusion of lovely white flowers with a pink blush. I have trained this plant for 50 ft. on either side of the stem. After blooming, the masses of seed pods have a rather pleasing effect until they change their russet for a black colour when ripe.

ALLAMANDA.

A genus of flowering shrubs of extreme beauty; ornamental also for their foliage. Several species thrive well in this State. Some of them are scandent, and have been described under the head of "Climbers." They are dwarf, bright yellow-flowering shrubs.

VARIETIES.

A. nerifolia; *A. Chilsonii*; *A. Hendersonii*; *A. cathartica* is a superb plant, but of a rambling and scandent habit, with very large, pure, bright yellow flowers; *A. Schottii* is somewhat similar, but not scandent, whilst the outer part of the tube of the corolla is deeply marked with red. There is a splendid variety, *A. sp.*, which produces truly magnificent flowers, fully 5 in. across, of a bright yellow colour, with the throat coloured with faint streaks of chocolate; the large unexpanded flower buds of a deep chocolate colour.

OLEANDER (Nerium).

Nerium odorum is a large, spreading shrub, to be seen in most Queensland gardens. It throws up from the ground numerous rod-like stems, upon the summit of which is borne its foliage of narrow, lanceolate leaves, surmounted by a profusion of bright rose, crimson, or white flowers. Propagated easily by layers or by division. It also yields seed abundantly. Other varieties are—*N. album*; *N. grandiflora*; *Mlle. Dubois*; *N. punctatum*; *N. rosea*; and *N. splendens variegatum*.

RONDELETIA.

Splendid ornamental flowering shrubs of great beauty; evergreen. They thrive well in light fertile loam, preferring a mild climate and shelter.

VARIETIES.

R. speciosa produces flowers of a rich vermilion, each with a deep-yellow eye; *R. punicea* is one of the handsomest ornaments of the garden. It bears throughout the warm weather, compact, moderate-sized trusses of beautiful orange-scarlet blossoms, somewhat like miniature heads of Auricula. Propagated by layers; bears seed scantily. *R. amara*, flowers pink; *R. hybridum* and *R. versicolor*.

BROWNEA.

A genus of flowering shrubs of unrivalled splendour, bearing in character and foliage a strong general resemblance to *Amherstia*, which has been described as about the most beautiful object in the whole vegetable creation.

VARIETIES.

B. Ariza: A shrub or small tree which bears from the ends of its stems a cluster of blossoms of prodigious size, much resembling a bunch of Rhododendron flowers, of a fine deep rose colour, and of extraordinary beauty. *B. grandiceps*: The flowers are produced in a short spike, tier above tier, every day witnessing the expansion of a new tier above those of former days, till at last the whole mass becomes a globe of living and glowing crimson. *B. coccinea* bears smaller heads of flowers than the preceding, but more numerous, and of a bright scarlet colour, exceedingly gorgeous and dazzling. *B. Antiquiensis* is another splendid variety.

These are very easy of propagation by layering, but the young plants, when put out, require great care, or they are sure to die off.

DURANTA.

Duranta Plumieri: A rather large, woody, thorny, but handsome spreading shrub, from 6 to 8 ft. high, with bright green foliage. Constantly in blossom, with numerous drooping bunches of bright azure-blue flowers, succeeded by pretty, orange-coloured berries of the size of a pea. It forms a very pretty garden hedge when properly trimmed. *D. Ellisii* has white flowers.

MAGNOLIA.

All the Magnolias are beautiful flowering shrubs. *Magnolia grandiflora*, however, is an evergreen flowering tree, growing well everywhere to a height of 15 ft. and more. It is noted for its noble laurel-like foliage and its showy, large, white, powerfully fragrant flowers. It occasionally ripens seed of a brilliant red colour.

M. anonæfolia is a pretty, shiny-leaved shrub, having curious, pale, chocolate-coloured flowers with a powerful odour, somewhat resembling port wine.

M. purpurea, *M. conspicua*, and *M. bicolor* are deciduous, with large purple and white tulip-shaped flowers.

M. fuscata (the port wine flower) has purple flowers, also bears small pale-yellow or cream-coloured flowers of a deep, dull-crimson within, of the size and form of a pigeon's egg, exquisitely fragrant.

M. pterocarpa is a large handsome tree, bearing in unbounded profusion its large, pure white, globular-formed, finely fragrant flowers.

The Yulan Magnolia, known botanically as *M. conspicua* (mentioned above), is a hardy deciduous tree that grows 20 or more feet in height. The flowers are tulip-like, white, erect, fragrant, and produced before the leaves, early in Spring. *Magnolia Soulangeana* is a dwarfer kind, supposed to be a cross between *M. conspicua* and the small, hardy, Japanese species *M. obovata*. It is much like its Chinese parent, but has the dark-coloured, purple flowers of the Japanese species, grows more compactly, and blooms more freely. Its flowers are pearl-white inside, the purple only showing on the outer surface of the petals, and is deliciously scented.

Both of these shrubs are difficult to transplant, and should be purchased in the Spring as pot plants, then set where they are to grow, and well heeled in, watering and shading the first year or longer, until well established. In the South it is well to set the plants where they will receive the protection of a wall or building, the south or east side being preferable.

Magnolia glauca is a choice variety, but is rarely mentioned in nursery-men's catalogues.

ALOYSIA (Verbena).

Aloysia citriodora: Lemon-scented verbena is well known for the fine fragrance of its leaves. It is a very common plant in our gardens. The flowers are insignificant. Propagated by laying down slips or cuttings in the cool weather. These readily strike in a pot filled with silver-sand and kept in a shady place.

CERATOPETALUM (Christmas Bush).

The Christmas Bush is a gem for a large garden. The flowers, on their first appearance in October, are white; soon afterwards they change to pink, and as the petals decay the calyx gradually assumes a deep crimson. A variety of this tree, *C. Apetalon*, grows to a height of 100 ft., and *C. gummiferum* to 40 ft. Thus, although included here, they cannot be considered shrubs any more than *Magnolia pterocarpa*.

CODIÆUM, *syn.* CROTONS.

A genus of large shrubs, remarkable for their exceedingly ornamental foliage. Only under exceptional circumstances can these beautiful shrubs be grown in the Southern parts of Queensland, as they are essentially tropical

plants, requiring heat and moisture, and will not stand frost. Northwards from Rockhampton they thrive to perfection, particularly in the moist tropical climate at Cairns, Geraldton, and Cardwell. Given the right climate, they will grow in almost any situation, but thrive far best, and assume a much more beautiful character, when planted completely in the shade. They are easily propagated by cuttings. The species and varieties have become exceedingly numerous, and most of them are very beautiful. They thrive on a compost of three parts loam, one part peat, one part vegetable mould, and a good proportion of sharp sand. Grown in the greenhouse, they require a great deal of water, and occasionally a little liquid manure.

VARIETIES.

C. pictum: A bushy shrub, about 4 ft. high, leaves 6 to 7 in. long, the upper surface of a pure rich green, marbled with blotches of cream-colour, and, here and there, as it were, spotted and stained with blood; the under surface is entirely of a deep blood-colour, blotched with cream-colour. *C. latifolium*: A somewhat larger and more diffusely growing shrub than the last, but hardly less beautiful. The leaves are 1 ft. long, of a fine polished green, with the midrib of a pure cream-colour, and stained, here and there, with spots of the same colour; under surface of a pale green. *C. variegatum*: A large shrub 3 or 4 ft. high, leaves in the form of straps, 6 in. long, of a deep polished green, with cream-coloured, blood-stained midrib; under surface smeared seemingly with blood.

Some other good varieties are *C. maximum*, a superb plant, the finest of all, with leaves 1 ft. long, and 3 or 4 in. broad; bright golden yellow, with band of dark, olive-green on each side of the midrib.

C. elegans, *C. acubaeifolium*, *C. irregulare*, *C. undulatum*, *C. Veitchii*, &c.

Propagating Crotons.

Everybody understands the necessity of bottom heat in the rooting of hard-wooded plants such as crotons, but beginners may not be equally aware that in like degree heat is required to aid these plants in their endeavour to establish themselves in the soil in which they have been potted, when sufficiently rooted for that operation. Very often a great many cuttings that have been successfully rooted succumb very soon after being potted, when they are placed on a light, airy bench, where neither sufficient moisture nor bottom heat was available for the stimulation of increased root action and the retention of foliage. All tender plants, on being potted out of the cutting bench, are more likely to thrive without check if they are, when potted, placed over a gentle bottom heat, and sufficient shade afforded them until they are fairly well established. An ideal method of procedure is to put them in an enclosed glass case, or frame, until they are in such a condition that they will proceed to grow without fear of injury. When crotons are needed for outdoor bedding, the stock from which cuttings have been taken can be utilised for filling in, if there is a likelihood of scarcity of plants for that purpose. Mossing the tops of crotons is a satisfactory method of obtaining well-furnished specimen plants without having to wait for like results from rooted cuttings. There should be no undue haste in severing the tops.

HOW TO TREAT HARDY SHRUBS.

In the "Florists' Exchange" the following advice is given on this point by Mr. S. C. Moon:—

I will assume that we all understand by the term "hardy shrubs" the class of perennial, bushy plants, deciduous and evergreen, though largely deciduous, which are used for ornamenting lawns and gardens. Though most are of moderate size when planted, some of them eventually attain the proportions of small trees. The term "hardy" will vary with the location of the

planting, but will not materially affect the suggestions here presented. How to plant them will be considered in a twofold light; first, the distribution and arrangement of the plants on the lawn; second, the method of setting the roots in the ground.

PLANTING IN MASSES MOST EFFECTIVE.

As a general rule the most effective way to plant shrubbery is in masses, with not too much variety in one group. Professor Bailey says: "The shrubbery masses should be placed on the boundaries, for it is a fundamental concept of landscape gardening that the centre of a place should be open. In most places, the mass, or border planting, should be the rule, and the isolated specimens the exception; but, unfortunately, the rule is usually reversed." It is easy to see conspicuous evidences of the truth of these statements in almost any suburban neighbourhood in examples of both good and poor arrangements.

Many planters seem to think it desirable to have a well-developed plant of as many varieties as can find accommodation on the lawn in order that they may enjoy each plant individually as it passes through its varying changes of foliage, flowering, fruitage, and leaflessness throughout the year. Such an arrangement may be appropriate for an arboretum or trial ground, and there are special charms in such a collection of shrubs as each successfully comes into bloom. But as the blooming period of most shrubs is only from two to four weeks, the beauty of foliage hues, both in the greenness of summer and autumn colourings, is an important consideration in arrangement of shrubbery groups. The introduction of bright-coloured foliage, such as golden elder or philadelphus, variegated weigelia, purple-leaved plum and barberry, &c., is occasionally done very effectively, but more frequently the result is a conspicuous blotch amid the verdure. The handling of bright colours always requires a high degree of artistic skill, or the result will be displeasing to the most refined tastes, affording valuable object lessons to the student and gardener, but it is not the way to produce the most effective results in lawn adornment.

To quote again from Professor Bailey's essay on shrubbery: "Plants scattered over a lawn destroy all appearance of unity and purpose in the place. Every part of the place is equally accented. The area has no meaning or individuality. The plants are in the way. They spoil the lawn. The place is random."

In large grounds the shrubbery border should be composed of successive masses of several plants of one species together, followed by another harmonious group of another sort, the border of the two groups interlacing with each other. Let the transition from one variety to another be gradual—not too sudden—and the groups not too large or too exclusive. An odd plant, taller or different from the others, may occasionally stand out or above its companions very effectively; of course, tall growers at the back flanked with smaller and low-branching species in the foreground.

It is not advisable to mix evergreen and deciduous shrubs in the same group. A few shrubs seem to be admirably adapted for filling-in plants. *Tamarix* is one of these which may often be used to relieve formality or to add variety in foliage effect, it being a tall, neat, inoffensive plant, which will harmonise with almost any other one. For low-drooping shrubs, to be used for carrying foliage from the grass lawn up to taller plants, few are more effective than *Spiræa Thunbergi*, *Stephanandra*, *Rhodotyphus*, and *Berberis Thunbergi*.

KNOWLEDGE OF PLANT HABITS ESSENTIAL.

The outlines of shrubberies should not be too straight or formal, but irregular and natural. A skilled florist or gardener should almost conceive these ideas without instructions, but definite knowledge of the habits of the different shrubs to be employed is essential to enable one to make a planting

which will develop consistently as they increase in age and size. That such information can only be obtained successfully by observation and experience is evidenced by the very large number of inharmonious combinations that are seen in shrubberies all about the country. Probably rhododendrons are treated injudiciously, and are a source of disappointment and waste of money more than any other shrub, largely through misunderstanding. Rhododendrons are sociable individuals, liking the companionship and protection of other plants. Their fine, fibrous roots delight in cool moist soil, but do not want to go very deep in earth to find these conditions, and are particularly sensitive to excessive heat or drought in midsummer. A situation where the shadows of large trees or buildings will shield mid-day sun in summer and winter, and from severe winds, is an ideal position. A perpetual mulch of leaves renewed each autumn, and with a light coat of stable manure on top of the leaves to keep them from blowing away, is most congenial to them. Mulching and shelter from wind are the most essential conditions.

Times of Sunrise and Sunset at Brisbane, 1909.

| DATE. | JANUARY. | | FEBRUARY. | | MARCH. | | APRIL. | | PHASES OF THE MOON.
<small>H. M.</small> |
|-------|----------|-------|-----------|-------|--------|-------|--------|-------|---|
| | Rises. | Sets. | Rises. | Sets. | Rises. | Sets. | Rises. | Sets. | |
| 1 | 4:57 | 6:46 | 5:21 | 6:42 | 5:40 | 6:20 | 5:57 | 5:46 | 7 Jan. ○ Full Moon 0 13 a.m. |
| 2 | 4:57 | 6:46 | 5:22 | 6:41 | 5:41 | 6:19 | 5:58 | 5:45 | 15 " ☽ Last Quarter 4 11 " |
| 3 | 4:58 | 6:46 | 5:22 | 6:41 | 5:42 | 6:18 | 5:58 | 5:44 | 22 " ☿ New Moon 10 12 " |
| 4 | 4:59 | 6:46 | 5:23 | 6:40 | 5:42 | 6:17 | 5:59 | 5:43 | 29 " ☾ First Quarter 1 7 " |
| 5 | 4:59 | 6:46 | 5:24 | 6:40 | 5:43 | 6:16 | 5:59 | 5:42 | 5 Feb. ○ Full Moon 6 25 p.m. |
| 6 | 5:0 | 6:47 | 5:25 | 6:39 | 5:44 | 6:15 | 6:0 | 5:41 | 13 " ☽ Last Quarter 10 47 " |
| 7 | 5:1 | 6:47 | 5:25 | 6:38 | 5:44 | 6:14 | 6:0 | 5:40 | 20 " ☿ New Moon 8 52 " |
| 8 | 5:2 | 6:47 | 5:26 | 6:38 | 5:45 | 6:13 | 6:1 | 5:39 | 27 " ☾ First Quarter 0 49 " |
| 9 | 5:2 | 6:47 | 5:27 | 6:37 | 5:45 | 6:12 | 6:1 | 5:38 | 7 Mar. ○ Full Moon 0 56 p.m. |
| 10 | 5:3 | 6:47 | 5:28 | 6:36 | 5:46 | 6:11 | 6:2 | 5:37 | 15 " ☽ Last Quarter 1 42 " |
| 11 | 5:4 | 6:47 | 5:28 | 6:36 | 5:46 | 6:10 | 6:2 | 5:35 | 22 " ☿ New Moon 6 11 a.m. |
| 12 | 5:5 | 6:47 | 5:29 | 6:35 | 5:47 | 6:9 | 6:3 | 5:34 | 29 " ☾ First Quarter 2 49 " |
| 13 | 5:5 | 6:47 | 5:30 | 6:34 | 5:48 | 6:7 | 6:3 | 5:33 | 6 Apr. ☾ Full Moon 6 28 a.m. |
| 14 | 5:6 | 6:47 | 5:30 | 6:33 | 5:48 | 6:6 | 6:4 | 5:32 | 14 " ☽ Last Quarter 0 30 " |
| 15 | 5:7 | 6:47 | 5:31 | 6:33 | 5:49 | 6:5 | 6:4 | 5:31 | 20 " ☿ New Moon 2 51 p.m. |
| 16 | 5:8 | 6:47 | 5:32 | 6:32 | 5:49 | 6:4 | 6:5 | 5:30 | 27 " ☾ First Quarter 6 36 " |
| 17 | 5:9 | 6:47 | 5:33 | 6:31 | 5:50 | 6:3 | 6:6 | 5:29 | |
| 18 | 5:9 | 6:47 | 5:33 | 6:30 | 5:50 | 6:2 | 6:6 | 5:29 | |
| 19 | 5:10 | 6:46 | 5:34 | 6:29 | 5:51 | 6:1 | 6:7 | 5:28 | |
| 20 | 5:11 | 6:46 | 5:35 | 6:28 | 5:51 | 6:0 | 6:7 | 5:27 | |
| 21 | 5:12 | 6:46 | 5:35 | 6:28 | 5:52 | 5:59 | 6:8 | 5:26 | |
| 22 | 5:12 | 6:46 | 5:36 | 6:27 | 5:52 | 5:57 | 6:8 | 5:25 | |
| 23 | 5:13 | 6:46 | 5:37 | 6:26 | 5:53 | 5:56 | 6:9 | 5:24 | |
| 24 | 5:14 | 6:45 | 5:37 | 6:25 | 5:53 | 5:55 | 6:9 | 5:23 | |
| 25 | 5:15 | 6:45 | 5:38 | 6:24 | 5:54 | 5:54 | 6:10 | 5:22 | |
| 26 | 5:16 | 6:45 | 5:38 | 6:23 | 5:54 | 5:53 | 6:10 | 5:21 | |
| 27 | 5:17 | 6:44 | 5:39 | 6:22 | 5:55 | 5:52 | 6:11 | 5:20 | |
| 28 | 5:17 | 6:44 | 5:40 | 6:21 | 5:55 | 5:51 | 6:12 | 5:19 | |
| 29 | 5:18 | 6:43 | ... | ... | 5:56 | 5:50 | 6:12 | 5:18 | |
| 30 | 5:19 | 6:43 | ... | ... | 5:56 | 5:48 | 6:13 | 5:17 | |
| 31 | 5:20 | 6:42 | ... | ... | 5:57 | 5:47 | ... | ... | |

Statistics.

COMMONWEALTH METEOROLOGY.

RAINFALL OF QUEENSLAND.

TABLE SHOWING THE TOTAL RAINFALL FOR EACH MONTH OF THE YEAR IN THE AGRICULTURAL DISTRICTS OF QUEENSLAND.

| STATIONS. | 1908. | | | | | | | | | | | 1909. | |
|------------------------------|-------|-------|--------|-------|-------|-------|------|-------|------|------|------|-------|-------|
| | Feb. | Mar. | April. | May. | June. | July. | Aug. | Sept. | Oct. | Nov. | Dec. | Jan. | Feb. |
| <i>North.</i> | | | | | | | | | | | | | |
| Bowen | 5·63 | 9·46 | 3·73 | 0·89 | 0·45 | 0·88 | 0·51 | 0·96 | 2·47 | 0·42 | 0·42 | 15·45 | 4·62 |
| Cairns | 8·03 | 20·60 | 5·99 | 3·05 | 0·59 | 3·70 | 2·12 | 0·74 | 3·07 | 1·60 | 1·41 | 32·05 | 5·25 |
| Geraldton | 13·27 | 33·00 | 14·23 | 18·52 | 2·64 | 8·11 | 3·66 | 2·81 | 6·93 | 3·80 | 1·69 | 47·92 | 10·29 |
| Gindie State Farm | 7·17 | 6·25 | 0·02 | 0·112 | ... | 0·40 | 1·27 | ... | ... | ... | ... | ... | ... |
| Herberton | 5·02 | 8·92 | 1·40 | 0·38 | 0·31 | 2·36 | Nil | 0·51 | 1·27 | 0·61 | 0·78 | 12·41 | 2·29 |
| Hughenden | 5·18 | 6·91 | 0·30 | Nil | 0·05 | 0·68 | Nil | Nil | 1·67 | 1·94 | 1·05 | 7·55 | 1·55 |
| Kamerunga State Nurs. | 7·47 | 25·75 | 4·60 | 3·363 | 0·76 | 4·85 | 1·58 | ... | 3·64 | 1·69 | ... | ... | 3·52 |
| Mackay | 3·83 | 17·43 | 14·82 | 3·25 | 1·29 | 1·65 | 0·71 | 2·27 | 1·80 | 2·57 | 0·2 | 15·00 | 1·36 |
| Rockhampton | 9·64 | 9·77 | 2·62 | 0·85 | 0·10 | 1·08 | 0·84 | 0·20 | 2·14 | 2·47 | 1·37 | 9·01 | 2·01 |
| Townsville | 6·69 | 9·03 | 0·38 | 2·22 | Nil | 1·70 | 0·27 | 0·28 | 1·58 | 1·26 | 0·7 | 6·94 | 1·70 |
| <i>South.</i> | | | | | | | | | | | | | |
| Biggenden State Farm | 9·82 | 9·84 | 2·97 | 0·74 | 0·43 | 0·49 | 2·33 | 1·39 | 1·80 | 2·12 | 3·66 | 7·37 | 2·68 |
| Brisbane | 8·43 | 18·19 | 2·45 | 2·40 | 0·17 | 0·77 | 2·83 | 0·67 | 1·77 | 2·25 | 1·28 | 1·99 | 2·72 |
| Bundaberg | 2·82 | 7·35 | 4·13 | 0·67 | 0·39 | 0·75 | 1·56 | 1·10 | 2·39 | 0·73 | 3·34 | 6·52 | 3·70 |
| Dalby | 4·88 | 7·61 | 0·11 | 0·37 | 0·63 | 0·14 | 1·89 | 1·13 | 2·55 | 3·65 | 1·56 | 1·46 | 3·55 |
| Esk | 10·06 | 17·04 | 2·83 | 1·07 | 0·23 | 0·46 | 2·75 | 2·16 | 1·29 | 5·99 | 3·62 | 2·64 | 3·21 |
| Gatton Agric. College | 3·38 | 10·74 | ... | 0·10 | 0·16 | 0·6 | 2·71 | 1·84 | 1·93 | 5·71 | 1·29 | 1·94 | 5·00 |
| Gympie | 11·77 | 8·08 | 1·87 | 2·00 | 0·38 | 1·16 | 2·87 | 1·37 | 2·49 | 2·58 | 3·97 | 3·86 | 3·77 |
| Ipawich | 6·63 | 13·77 | 2·71 | 1·14 | 0·12 | 0·47 | 3·23 | 1·19 | 1·48 | 5·09 | 1·05 | 1·37 | 1·95 |
| Maryborough | 8·07 | 11·40 | 2·52 | 1·05 | 0·46 | 0·81 | 1·98 | 1·05 | 1·84 | 1·92 | 1·64 | 8·36 | 7·11 |
| Roma | 6·38 | 2·51 | 0·22 | Nil | 0·55 | 0·63 | 1·38 | 1·12 | 2·15 | 2·79 | 1·68 | 5·19 | 4·85 |
| Roma State Farm | ... | ... | ... | ... | ... | 1·27 | 0·73 | ... | ... | ... | ... | ... | ... |
| Tewantin | 12·47 | 14·39 | 7·59 | 8·66 | 0·75 | 1·97 | 2·70 | 2·18 | 2·30 | 7·50 | 4·12 | 6·44 | 3·31 |
| Warwick | 4·52 | 6·65 | 1·40 | 0·15 | 0·80 | 1·24 | 2·69 | 1·96 | 0·96 | 5·28 | 2·02 | 0·87 | 0·82 |
| Westbrook State Farm | 8·03 | 1·41 | 1·40 | 00·5 | ... | 0·49 | 1·97 | ... | ... | 2·05 | ... | ... | 2·61 |
| Yandina | 14·47 | 16·62 | 5·45 | 4·59 | 0·58 | 2·64 | 2·18 | 1·50 | 3·10 | 6·03 | 2·75 | 6·69 | 6·42 |

NOTE.—The rainfall data in this table are compiled from telegraphic reports, and must be considered as approximate only.

GEORGE G. BOND,

Divisional Officer.

Science.

ANALYSES OF ENSILAGE.

By J. C. BRÜNNICH, Agricultural Chemist.

The accompanying analyses of ensilage will doubtless prove of great interest to farmers and others. It will be noted that a sample of weed ensilage was forwarded from the State school, Doctor's Creek, Meringandan, which Mr. Brünnich considers to be highly nutritious fodder, provided strong-smelling weeds are not present. It is highly satisfactory to find a school teacher taking an interest in agricultural matters, and we shall be very pleased to hear from more of them on such subjects.

| Variety and Locality. | Dry Subs. in Green Material. | Moisture. | Ash. | Fibre. | NUTRIENT MATTER. | | | | Albumenoid Ratio. | Remarks. |
|---|------------------------------|-----------|-------|--------|-----------------------------|--------------|-------------------|------------------------|-------------------|---|
| | | | | | Carbohydrate by Difference. | Fat and Oil. | Protein N x 6.25. | Total Nutrient Matter. | | |
| 1. Weed, State School, Doctor's Creek | 41.50 | 7.96 | 14.83 | 33.76 | 28.99 | 2.91 | 11.55 | 43.45 | 1:6.4 | FROM A PRT SILO.
Filled March, 1908. Taken September, 1908. Odour is rank and aromatic. Eaten by cattle, but not readily. Some of the weeds which still could be identified were— <i>Spinach (Amaranthus spec.)</i> , Stinking Roger (<i>Tagetes glandulifera</i>), Fat Hen (<i>Chenopodium carinatum</i>), and also Vitadmia (<i>Lepidium onderab</i>). Taken October, 1908, 3 feet from bottom of silo. Readily eaten by stock. Acidity = 1.00 % lactic acid |
| 2. Sorghum, Biggenden State Farm, rather more than full matured | 30.90 | 6.80 | 13.96 | 38.85 | 31.01 | 1.56 | 7.32 | 39.89 | 1:10.8 | 2nd growth Early Orange Sorghum. Filled June, 1907. Taken August, 1908. Sample showed well-formed seeds. HCN absent. More readily eaten by stock than older silage. Acidity, 1.30 % lactic acid |
| 3. (Immature) Sorghum, Biggenden State Farm | 23.40 | 7.30 | 13.63 | 30.20 | 40.69 | 1.62 | 6.56 | 48.87 | 1:13.0 | Age of ensilage, 19 months. Stock eat it readily. Milk is flavoured by it (from a 60-ton galvanised-iron lined silo). Acidity, 1.08 % lactic acid |
| 4. Sorghum, State Farm, Roma (Planter's Friend) | 28.00 | 8.20 | 11.28 | 35.76 | 39.82 | 1.74 | 3.20 | 44.76 | 1:27.1 | |

1. The ensilage made from weeds is a highly nutritious fodder, and only the strong flavour of some of the weeds would be a drawback when feeding milking cows.
- 2 and 3. There is not much difference between the over-ripe and barely ripe sorghum; both were absolutely free from hydrocyanic yielding glucoside. It appears that the time when sorghum is coming well into hand is the best to make ensilage, as already previous investigations have shown clearly that the fodder at that period of growth is quite safe.
4. This is a very poor sample of ensilage, being deficient in nitrogenous matter.

Tropical Industries.

COCOANUT CULTURE.

By A. H. BENSON, Instructor in Fruit Culture.

The cocoanut palm is essentially a tropical plant, and requires a good and even rainfall, combined with an equable climate for its proper development. These conditions are obtainable throughout the islands of the Pacific and Indian Oceans lying within the tropics, the south-eastern coast of Asia, the east and west coasts of tropical Africa, the West Indian Islands, and parts of the eastern tropical seaboard of America.

As far as Australia is concerned, the area in which cocoanut culture is commercially possible is confined to the north-eastern seaboard of Queensland and the island of New Guinea.

The district in Queensland in which the climatic conditions are suitable for the growth of cocoanuts extends along the north-eastern coast line from the mouth of the Herbert in the South to Princess Charlotte Bay in the North, a distance of some 400 miles.

Cocoanuts can be grown to the south of the Herbert, at Townsville, Bowen, and Mackay, also to the north of Princess Charlotte Bay; but I am of opinion that their cultivation commercially will be within the limits I have mentioned—viz., from 14 deg. to 18 deg. south. So far, the growing of cocoanuts has not been attempted on a commercial scale in this State, although a considerable number of trees are scattered along the coast at different points. A fair market is obtained for the ripe nuts, but the manufacture of copra and the utilisation of the coir has not been attempted, except in a very small way.

Sufficient experience, however, has been gained to show us that we can grow good nuts, and that we can produce good copra from such nuts; in fact, no better copra was exhibited at the recent Franco-British Exhibition than the samples that were prepared by Mr. J. Robbins, of Port Douglas, for this Department, and our cocoanuts compared favourably with any in the show.

There is a considerable area of coast country within the limits I have given that is suitable for the cultivation of cocoanuts, much of it land that is practically valueless for any other purpose. Sandy loamy soils on the bench lands or coast foothills adjacent to the ocean beach grow the cocoanut to perfection; in fact, it is from soils of this nature that the best of the nuts at Singapore, the Federated Malay States, and Ceylon are obtained.

The cocoanut is one of the most valuable plants of the tropics, as not only is it used in its fresh state for human consumption, but every part of the tree and fruit is made use of. One has only to visit a cocoanut-growing country to appreciate its worth, as besides providing many important food products, both in its green and ripe condition, the leaves are used for mats, baskets, and thatching houses, or for torches; the ash of the leaf is rich in potash, and makes a good lye; the husk of the nut supplies a fibre valuable for brush, mat, matting, mattress, and rope making, and the shell of the nut is made into a good many articles for household use, and is a good fuel. The trunk of the palm is useful for all kinds of buildings, bridge work, &c.; a drink is prepared from the sap that is extracted from the flowers; a spirit is distilled from this sap, and a sugar is obtained from same by boiling. In addition to the value of the nut as a food product when used fresh, it is dried and made into copra, from which an oil valuable for many purposes is extracted. The finest cocoanut oil is converted into a number of food products, such as vegetable butter, and the inferior oil is used for soap-making. The refuse left after the extraction of the oil is used for feeding stock.

Recognising the value of the cocoanut, and knowing that we have a considerable area of land in this State adapted for its cultivation, I took the opportunity of my recent visit to the old country and to the East to obtain all the information that I could respecting the best varieties of nuts to grow, the best methods of growing same, and the best method of utilising the nuts when grown.

In the first place, I was anxious to obtain reliable information as to where the best nuts are grown, as should the industry be started on a commercial scale here, it would be a very great advantage to start with the right kind of nut. In order to obtain this knowledge, I visited Kew Gardens and the Imperial Institute whilst in England, as well as the Botanic Gardens at Singapore, Penang, and Peradynia, in Ceylon. The result of my inquiries and personal observation is to the effect that this is by no means an easy matter to determine, as equally good nuts are to be found in districts that are very distant from each other, and, as far as I could make out, there has been no systematic attempt amongst growers anywhere to produce superior types of nuts. The bulk of the cocoanuts grown in the East are probably derived from the common Java type. As all nuts are reproduced from seed, there are naturally very many different types, not only as regards the size, colour, and shape of the nut, but in the habit of growth of the tree, time the tree takes to come into bearing—prolificness or otherwise. There is also a very great difference in the nuts themselves—some have a heavy coir and a comparatively small nut, whilst others have a large nut and little coir. The size of the nut is not by any means a reliable indication of the quantity of copra it will yield, as some of the largest nuts have quite a thin flesh that dries light, and some of the smaller nuts a thick flesh that yields a good percentage of copra.

Mr. T. W. Main, of the Botanic Gardens, Singapore, when questioned by me respecting varieties of cocoanuts grown in Singapore and the Federated Malay States, replied that although the Malays recognise several types known to them as "Kalapa Gading," the common hard nut; Kalapa Lugi, a nut that is all edible husk, shell and nut in the young state; Kalapa Puouah; Kalapa Idjo, the immature or green nut of any type; it is probable that they have all been derived from the old original of Java and surrounding islands. Mr. Main also informed me that with the exception of selecting fairly good nuts for planting, there was no attempt made to improve either the yield or quality of the nut. This information was confirmed by Mr. Fox, of the Penang Botanic Gardens, and by Mr. R. H. Lock, of the Royal Botanic Gardens, Peradynia, Ceylon, and was borne out by my personal observations and the inquiries that I made in the plantations owned by Chinese, Malays, and Javanese.

This want of care in the selection of the seed nuts was somewhat of a surprise to me, as I would have expected the planters to have taken particular care in this respect, and to have seen, at any rate, that the seed nuts were obtained from trees yielding heavy and regular crops of nuts giving a high yield of copra.

This want of care in selection is apparently not confined to the Malay Peninsula, Ceylon, and India, as in a "report on cocoanuts in Manila," by Mr. William S. Lyon, Chief of the Division of Plant Industry of the Bureau of Agriculture, published in 1903, attention is drawn to this particular, and an instance is given of a planter who possessed a remarkably prolific tree, that had produced not less than 200 nuts annually for twenty-three years, and yet had never thought of selecting the nuts from this particular tree for planting.

This failure to improve the yield and quality of the nuts by careful selection of seed is unfortunate in that all we can do, should we obtain seeds of the best types from the Indian Archipelago or elsewhere, is to get the best nuts we can, and when same come into bearing to carefully select the seed for future planting from those trees only that show especial merit.

SOILS SUITABLE FOR THE CULTIVATION OF COCOANUTS.

There are two essentials to be borne in mind when selecting soils for cocoanut culture—the first is, that the soil be of such a nature that it will permit of the proper development of the root system of the cocoanut; and the second, that there is no stagnant water at the roots. The first essential quality is found in sandy or sandy loamy soils of a free nature, and the second is a matter of drainage. Besides being of a free nature, the soil should have a good depth, so as to provide plenty of room for root development. An abundance of water in the soil is not a drawback, provided that the water is flowing and not stagnant, as is shown by the fact that extremely fine palms are grown right on the seashore, or on the banks of tidal or other creeks, where their roots are frequently covered with salt or fresh water—water that is moving, not stagnant, as the latter will eventually kill the palm.

Naturally, a soil rich in plant food is to be preferred to one that is deficient in this respect, though from what I have seen of the growth of cocoanuts, the right mechanical condition of the soil has even more to do with the success of the plantation than the richness of the soil.

There are thousands of acres of sandy or sandy loamy soils adjacent to the beaches of north-eastern coastal Queensland that are in the right condition mechanically for the growth of cocoanuts, and that compare favourably with the coast soils of Ceylon and the Federated Malay States, on which cocoanuts are so largely grown. As far as my observation went, decidedly the best palms and nuts were grown on the sandy soil adjacent to the seaboard, the palms grown inland being very inferior to those grown on the coast. The cocoanut palm wants no shelter; in fact, it will not thrive unless it is exposed to all the winds that blow, and it is possibly owing to this fact that it does so well on or near the shore, where it gets the full force of the sea breezes.

PREPARATION OF THE LAND.

In the East this is usually a very simple matter. The timber is first cleared; holes are then sunk at convenient distances; sometimes these holes are manured and the young plants are set out therein. The subsequent cultivation is merely keeping a ring round the tree free from weeds and the breaking of any scrub or heavy weeds that may spring up between the row of palms till such time that they are tall enough to be out of the way of cattle, when buffaloes are depastured between the palms and keep down the grass and weed growth. This system, however, is unsatisfactory, as it does not give the palms a fair chance, and the yield of plantations started and treated in this manner is very much less than it would be were greater care to be taken to prepare the land properly and to take better care of it when so prepared. In Queensland it will pay us to take much greater care in the preparation of the land. All timber, brush, &c., should be removed and the land stumped, at any rate well enough to permit of the use of a stump-jump plough, so that the surface soil can be well worked and blady grass and other weeds killed. If the soil is of the free nature that is most suitable for cocoanuts, deep cultivation will not be necessary, as all that is needed is to get the surface soil in a good state of tilth and keep down weed growth by means of surface cultivation. Although the initial expense will be greater, the subsequent cost of keeping the land clean will not be great, as the soils that I have described are easy to work and to keep free from weeds. The young palms planted under such conditions are not checked in their development, but will grow rapidly, and, should the surface soil be kept stirred, they will not suffer from any short spell of dry weather, as the soil, if worked, will retain moisture well. Should there be stagnant water below the soil, as will be probable on some parts of the coast, then it will be necessary to provide deep open drains emptying on to the beach or into a creek—tidal or otherwise—to carry it off. If this is done, the land will grow cocoanuts all right, and there will be no fear of injury to the roots.

PLANTING.

The nut is not, as a rule, planted out where it is to be grown permanently, but is first sprouted in the nursery and then transplanted to its permanent position. The nursery is in partial shade, and the nuts as gathered from the tree are placed in small heaps on the surface of the ground. If it is rainy weather they will sprout all right without much trouble, the time of sprouting varying from one to as much as six months. If the weather is dry the nuts should be watered occasionally to prevent their drying out.

When the nuts show signs of sprouting go over the heaps and take out those nuts in which the root is showing through the husk, and place them singly in the ground, so that the young top may come away straight.

When the young plants have made a growth of 18 in. to 2 ft. in the nursery, they are ready to plant out. They are often left till they are much bigger, but the general opinion is that they are less liable to get a setback if planted out at the size mentioned. Holes are dug at distances of 30 ft. apart each way, and if the previous cultivation of the land has been carried out thoroughly there is no necessity to go in for preparing them elaborately. All that is necessary is to take out the soil 2 to 3 ft. square to a depth of about 2 ft. Place a few spades' full of good surface soil mixed with cow manure, if obtainable, or with good vegetable mould, in the bottom, and place the nut on same with the top upright. Put a little fine top soil round the roots and press same fairly with the hand, so that the nut cannot shift. Don't fill up the hole—as the palm grows it will fill it, and will thus have a good hold of the ground. The best time to set out the young plants is the beginning of the rainy season, which in the part of Queensland that is suitable for their growth would probably be early in January.

Once the young plants are set out all that is necessary is to keep all stock out of the plantation and to cultivate the land when necessary, to keep down weed growth and to retain moisture in the soil.

I have advised planting the palms 30 ft. by 20 ft., as this distance is found to be about the best. Many palms are planted much closer together, but the closest planting does not give the top room to develop, and the plants are apt to become spindly and crop indifferently; further, the greater distance apart gives more room for root development, a matter of considerable importance when the soil is not too rich.

MANURING.

The cocoanut makes a fairly heavy demand on the soil for nitrogen and potash, and to a certain extent on phosphoric acid. Lime is also an essential, but, as a rule, in the soils that I have mentioned there is generally a sufficiency of shell sand incorporated with the soil that will supply all that is required of this particular food. An abundant supply of nitrogen is essential in the earlier periods of the plant's growth, as it is conducive to a vigorous leaf development, which in turn encourages a strong root growth. Potash, although it enters largely into the composition of the stem and leaves, will not be seriously depleted from the soil till the trees come into bearing, after which the application of potash as a manure will probably be found to have a very distinct influence on the yield of nuts produced by the palms.

With regard to nitrogen, as far as Queensland is concerned, the cheapest way of applying this important plant food is by the growing of leguminous crops such as cowpeas, Mauritius beans, velvet beans or pigeon pea between the rows of palms, and then ploughing them in direct, or, if this is not feasible, to brush them down and allow them to rot on the ground where grown. Ploughing the crop in is, however, to be preferred, as when this is done the surface soil can be kept in the high state of tilth necessary to retain the moisture during the dry season. Where available, cow or other animal manure spread around the trees and worked in has a beneficial effect, but as

this manure is not always obtainable in the districts that are suitable for the growth of coconuts in this State, we will have to depend mainly on green manuring and commercial fertilisers. In the East practically no manuring other than that of spreading cattle manure round the trees and forking same in is given, but from what I saw on many of the plantations that I visited I am satisfied that many of the trees would have been benefited by more generous treatment, as not only were the trees yielding a small crop of nuts, but the vigour and growth of the trees showed a want of plant food.

SUBSIDIARY CROPS.

As the coconut takes some eight years to come into bearing, the question naturally arises, is it not possible to get some return from the ground, from crops grown between the rows of trees? This can be done, provided that care is taken to grow the right kinds of crops, and that these crops are manured in such a manner that they will not deplete the soil of its available plant foods, and thus rob the palms of the nutriment required for their proper development. Crops such as pineapples, peanuts, cotton, or sweet potatoes can be grown; also possible, cassava, although the latter is a very exhaustive crop, and will require heavy manuring to replenish the nitrogenous matter it has taken from the soil. Where subsidiary crops are grown it will be necessary not only to manure with farmyard manure or commercial fertilisers, but the growing of green crops and ploughing in of same will be necessary between the successive plantings of the supplementary crops.

GATHERING THE CROP.

The nuts should be gathered when ripe, care being taken not to remove immature fruit. The old practice of allowing the nuts to fall on the ground is unsatisfactory, as the nuts are apt to deteriorate thereby. Nuts required for seed purposes should not be thrown on the ground, as this may crack the shells and prevent germination. If possible, the trees should be climbed, without injuring the trees, as done in the South Seas. If, however, men can not be found to climb the trees in this manner, then notches for the insertion of the foot should be cut in the trunk, provided that the trunk is sufficiently mature not to be injured thereby, and that the cuts are made sloping downwards, so as not to retain the rain. This is the method adopted by the Chinese growers, and is not found to injure the trees to any extent, although it has the drawback that it enables borers to obtain entry into the trunk.

MANUFACTURE OF COPRA.

The nuts, when gathered, are carried to a shed, where they are first husked. The implement used for husking the nuts is a stout stake driven into the ground and fitted with a strong steel spear top having two cutting edges. The nut is driven on this by hand, and the husk forced off. The husked nut is then cut or broken in half in order to allow the milk to escape and permit of the removal of the copra. The nuts when cut open are usually allowed to remain in the sun for a few hours to partly dry, as this is found to facilitate the removal of the copra. A short stout knife with a curved blade is used to remove the copra. The copra is then dried, either by placing same on the ground in the sun or by drying it over specially constructed kilns. The former takes some three days in favourable weather, whereas kiln drying only takes about twenty-four hours. The kilns used for this purpose are of a very simple nature, and consist of a long furnace, about 3 ft. wide, with brick sides about 2 ft. 6 in. high, covered with sheet iron on which clean white sand is placed. The copra is placed on the sand till dry. The heat used for the drying is obtained by burning the shells. This is a very crude method, and I am satisfied that up-to-date fruit evaporators would do the work more satisfactorily, and produce a much superior article.

UTILISATION OF THE COIR.

In India, Ceylon, and the Straits Settlements only the very crudest methods are employed in dealing with the coir. The husks are soaked in water for twelve hours or longer, and are then first pounded with heavy hammers. They are then pounded with wooden mallets, and then dried in the sun. When dry they are placed in a heap and beaten with rattan canes to tease out the fibre. This process is a very slow and costly one, and is only possible in countries where there is the very cheapest of labour. In Java machinery for crushing the husks and extracting the fibre is now in use, and besides producing a superior article, it is worked much more expeditiously and cheaply. Machinery suitable for this purpose is manufactured by Thos. Larmuth and Co., Limited, Todleben Ironworks, Cross Lane, Salford, Manchester.

The fibre, after passing through the crushing operations, passes through a winnowing machine, to remove the dust and non-fibrous material, and is then ready for spinning.

In order to make the industry a success in this State I am of the opinion that it will be necessary for the individual planter, or a combination of planters, to erect up-to-date machinery for the preparation and drying of the copra, and also, possibly, for extracting the oil from same, as well as the best machinery for working up the coir. There is a good market for both the oil and the refuse oil cake, as well as for the prepared fibre, in Australia; and, as far as one can judge, there is no reason why cocoanut culture should not be a success here. There is one other question to be considered, and that is the smallest area of cocoanuts in bearing that will be required to keep such machinery going, and the opinion of Mr. L. J. Brown, Inspector of Cocoanut Plantations, F.M.S., is to the effect that 2,000 acres will support an oil and coir factory, and Mr. Wm. S. Lyon, of Manila, whose opinion I have quoted recently, is of the opinion that the minimum size of a plantation on which economical application of oil and fibre preparing machinery could be used is 60 hectares (150 acres).

NEW FIBRE PLANT (PITA DEL OPON).

A correspondent of the "Revista del Ministerio de Obras Publicas," Republic of Colombia, describes what is apparently a new and very valuable fibre plant, recently discovered in the forests of the Carare River, a tributary of the Magdalena, in the Santander district and of those of the Opon, where the plant is said to cover many square leagues of country, and is said to be truly a marvel amongst textile plants. The leaf of the plant contains a fine, delicate, tenacious, resistant fibre of extraordinary length, of whitish-lead colour, silky and brilliant, of great flexibility, softer and smoother than the finest cotton. It is a species of Pita, but the fibre is much finer than that of the plant known in Mexico by that name. The leaves are no less than 3 metres (nearly 10 ft.) long. It would not, says the writer, be astonishing if it were found to abound in the extensive forests of other hot districts of Columbia.

FERTILISING SMALL GARDENS.

Not everyone wants to apply fertilisers by the acre. There are gardeners who grow small quantities of vegetables and other crops, and who, having no available farmyard manure, have to use artificial fertilisers. The following will, therefore, be doubtless helpful to them:—

One thousand pounds of fertiliser per acre means that 1 lb. will serve for 44 square feet (or for a bed measuring 11 ft. by 4 ft.). One ounce is sufficient for 2·7 sq. ft. If 1 oz. is distributed over 5 sq. ft., it is equivalent to 1 lb. to 87 sq. ft., or 500 lb. per acre.

General Notes.

WINDMILLS.

The cheapest windmill is never the most economical one to buy. What is required in such a machine is, that all the iron-work shall be heavy and substantial, the wheel well braced, the fans securely fastened to the arms, and the vane supported by a brace. It must be capable of standing through the heaviest storm. A really good windmill should, with a reasonable amount of care, do good service for from twenty to twenty-five years with a very small amount of expense for repairs. It should be strong enough to do the heaviest work in a light wind; but do not expect a 10-ft. wheel to do the work of a 14-ft. wheel. In erecting a windmill, one thing of importance is to elevate the tower sufficiently high to place the lower curve of the wheel at least 10 ft. above all obstructions, such as trees, buildings, hills, &c., so that there may be a free current of air in all directions. Mistakes are often made in placing mills too low, so that the wheel is below the ridge of barns, or tops of trees near by. This not only prevents the mill from receiving the full force of the wind, but subjects it to varying currents that tend to toss the mill about from one point to another and prevent it from doing its work properly; and in strong winds the effect is sometimes damaging. It is better economy to erect a mill too high than too low, as, frequently, the upper current of air is moving sufficiently to run a mill while it would not run in the lower current. Again, the upper current is more steady at all times, and will run a mill at more uniform speed, with less strain.

The most important point of a windmill tower is the anchorage. Perhaps, the best way is to dig holes 4 ft. deep, and fill them with stone laid in water-lime or cement; in this is embedded, to serve as an anchorage, a 2-in. bar of iron, with one end flattened, and holes punched in it for the tower bolts. If it is not convenient, posts may be used with pieces spiked across the bottom for anchors; this is the method generally employed.

Twenty-seven thousand one hundred and fifty-four gallons of water will cover an acre 1 in. in depth, and 1-h.p., with good machinery, will raise this amount of water 1 ft. high in ten minutes; or 10-h.p. will raise it in one minute. One horse-power would put 1 in. of water on 1 acre, elevated 25 ft. above the source, in four and one-sixth hours. Ten horse-power would do the same for 10 acres. Now, from this we get the rule that for 1 in. of water on 1 acre of land we must figure 1-h.p. for ten minutes for each foot in height the water must be raised. It may be more explicit to add that 1-h.p. is defined as the combined pulling strength of four ordinary horses. In theory, a horse-power is equal to 33,000 lb. lifted 1 ft. high in one minute of time.—“Irrigation Farming,” by Lucius M. Wilcox.

DINGO TRAPPING.

The following instructions how to trap native dogs, which we reprint from an extract from the “Journal of Agriculture” of Western Australia, are taken from Mr. Ross’s method, and, with the illustrations and instructions carefully followed, any person should be able to trap any ordinary dingo.

Of course, when a dog becomes very cunning, it requires much more skill to catch him, and this is only obtained by experience.

Plate XXVII.

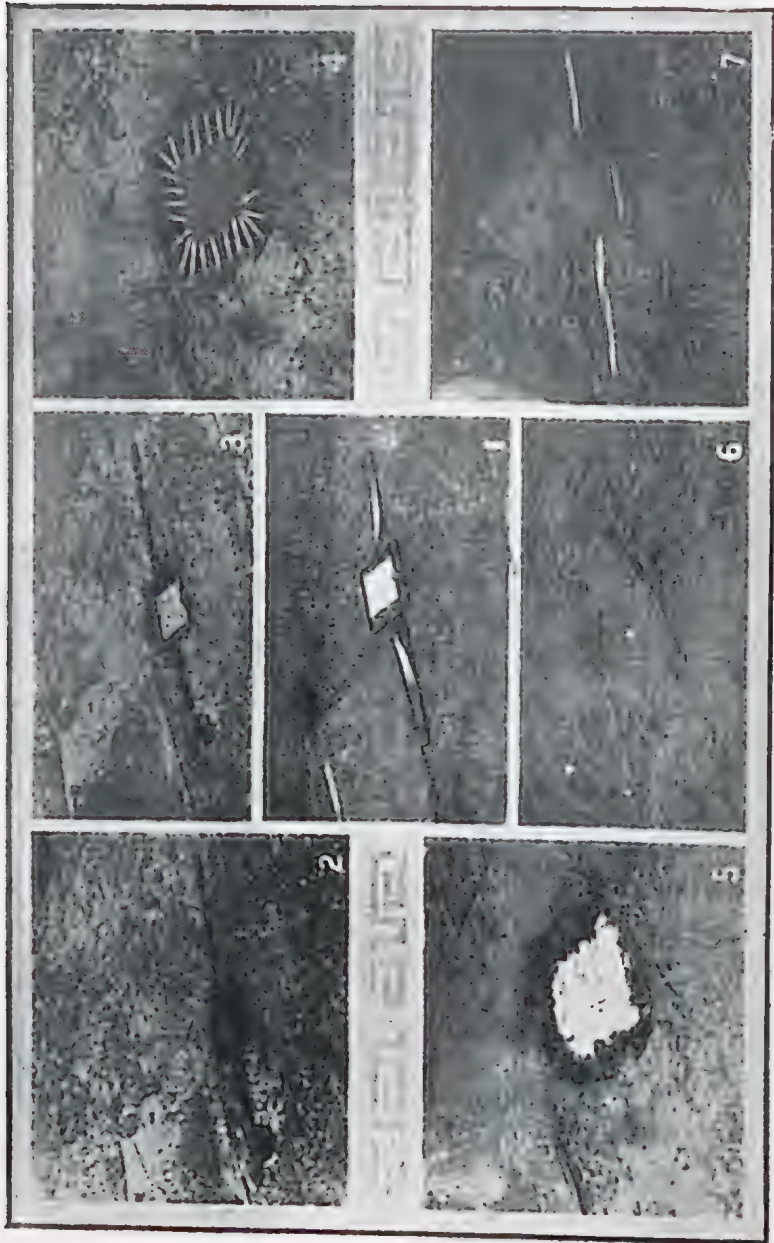

SETTING A DINGO TRAP.



To catch a dingo it is first of all necessary to allay all his suspicions of danger, either by sight or smell, about the ground where the trap is to be set, indicating that this has been tampered with in any way. The simple way of setting a trap without its being hidden, with a bait on it, will only catch very inexperienced dogs. The trap must be buried in such a way that it will easily snap, and the soil must be replaced in such a way that it does not differ from the surrounding country. A cutting is made in the ground exactly the size of the trap, and is then carefully covered over, as will be more fully described later on.

The first thing to do is to find the beat of the dingo. To anyone familiar with the country this should not be a difficult matter, as nearly all dogs have tracks on which they go regularly. It may be perhaps only once or twice a week, or possibly once in two weeks, as some dogs travel about much more than others. Nearly all dogs have regular scratching places, and if the beat cannot be found the scratching place is the next best place to set the trap. When you have found the dog's beat or his scratching place, be very careful not to approach it too closely, otherwise he may see your tracks or smell your scent. On no account ever walk in front of the place where the trap has to be set. When you have decided on the exact spot in which to place the trap, which, if you have found the dog's regular beat, should be on it, take a bag and put it carefully down almost on a level with the dog's track, and upon this bag stand or kneel, and on it also put the soil which is taken from the hole in which you bury the trap, then take the trap and set it down at right angles to the end of your bag, having the plate exactly in the dog's track, and always keeping the heel of the trap next to the bag, then with a knife carefully mark the outline of the trap; put the trap to one side now, and with your knife cut all round the marks you have made. Cut out the ground now on the inside of your marks as neatly as possible, taking out the centre of where the trap is to be first, and put all your loose soil upon the bag upon which you are kneeling. When doing this be careful not to rest your hand upon the ground anywhere near the dog's track, but after you have taken the soil out from the centre you can rest it there while you are taking out parts for the springs. When you have the hole sufficiently large and deep, set the trap, and put it carefully in the ground so that the plate will be $\frac{1}{4}$ -in. below the surface, then fill in over the springs very lightly. Use a little horse manure or light leaves to go round the side of the plate so as to prevent the soil from getting underneath them, as this must always be kept so as to allow the plate to drop when the dog's foot goes on it. Next put the soil carefully all around the jaws of the trap, and be very careful to see that there are no small stones or bits of wood in the soil that might possibly get in the jaws near the spring, and thus keep it from closing tightly. Get a light twig that will reach across the edge of the jaws diagonally, and place it carefully underneath the plate, resting it on the opposite corners of the jaws, so as to take the weight of the soil off the plate. The twig must be very light and easily broken, so that when the dog puts its foot on the plate the twig will snap and let the plate go down; then take some small twigs about the size of safety matches and place them from the edge of the plate to the edge of the jaws, as shown in illustration. When this is done get a piece of paper the size of the centre of the trap, making one or two tears about the centre of the paper so as to allow the air to escape. In the summer time the paper may be wet so as to make it easy to break, then take some sand or earth and work it around the inside of the trap, taking care to spill none outside. Then take a small stick and work it gently in the centre of the trap so as to bring the soil on the plate on a level with the surrounding soil. Be careful to put the same kind of soil or sand on the top as is on the surrounding surface. By blowing over the surface or by using your hat as a fan, the place where the trap is concealed may be quite easily hidden, so that it cannot be distinguished. Next take two or three twigs or sticks about $\frac{1}{4}$ in. thick and lay

them along where the springs are concealed, to within about $\frac{1}{4}$ in. off the jaws of the trap, then get a little rubbish, such as decayed vegetable matter, and place it on the end of these sticks level with the jaws, then get another twig about the size of a small penholder and place it just on the side of the trap over the catch of the tongue, so as to keep the dog from putting his foot on the tongue, to make sure that he will put his foot on the plate of the trap, as a dog will never put his foot on a little bit of stick like this if there is a smooth place for him alongside. It is advisable to put two small sticks, one at each end of this last one that has been put down, in case it should be shifted by lizards or small animals running over it. This stick that is put down about the size of a penholder should be a little longer than the plate itself. The jaws of the trap should never be very sharp, the teeth should be either blunted or wrapped on the ends with wire so as to prevent it cutting the dog's leg off, and thus allowing him to escape. The kind of trap that Mr Ross recommends is the 7-in. double-sprunged horseshoe trap with the falling plate, and he specially recommends anyone to avoid using the balance plate. (Horseshoe traps can be purchased at about 7s. each.) If a dog should happen to get caught and get away, the next time he comes along he will look out for the small sticks that have been set about the surface of the ground over the trap. To catch such a dog the best way is not to use sticks. All the dirt that has been taken from the hole and has been put on the bag and not replaced should be gathered up in the bag and taken some little distance and thrown away, but on no account leave any lying about where the trap has been set. Put nothing whatever in the way of bait on the traps, as this only attracts native cats, ants, and other small game, and may cause the trap to be snapped without catching the dog. If a dog runs a road where it is not safe to set a trap, the trap may be set on one side in the same method as before-mentioned, and the dog's attention attracted to the place by some of the dung and urine of other dogs. A little distance in advance of where the trap is set a sapling should be laid down in a slanting direction, with the nearest end towards where the trap is; the fact of the sapling being laid down will attract the dog's attention, and instead of jumping over it he will probably go round the end, and by so doing would probably smell the dung and urine laid as a lure for him. The dung should be just on the heel of the trap or back of the tongue. It should be exactly in this position, as when the dog goes to smell it he will then place his fore-feet exactly over the plate. In all cases be careful to remember that the heel or back of the trap must be kept next to the bag upon which you stand or kneel. When setting a trap on the side of a road like this, be careful on no account to walk in front of it, but keep at the back, and use the same precautions that were given in the first instance. It is better not to chain or wire the trap in any way, as even if the dog does make off with the trap it would be very easily tracked. The illustration will show the different methods from the marking out of the trap until the operation is complete. They are numbered from 1 to 7, and may be briefly referred to as follows:—Fig. 1, trap laid down ready to mark out ground; fig. 2 shows the hole made to place the trap in; fig. 3, trap in position; fig. 4, pieces of thin sticks or twigs to support paper; fig. 5, paper placed over plate in order to prevent dirt from getting underneath; fig. 6, trap covered and dirt dusted over it; fig. 7, sticks laid down on finished trap.

CURE FOR BLIGHT IN CATTLE.

Mr. H. Knight, of Bell, writes to say that, after trying several remedies as a cure for blight in cattle, he blew sugar of lead into their eyes when they were almost blind. Two applications were sufficient to effect a cure, the second dose being administered two days after the first.

FROZEN PIGS FROM CHINA.

It would hardly be expected that food-stuffs would be exported from a country whose inhabitants number from 400,000,000 to 600,000,000, and where famine widely extended is of frequent occurrence. Yet Sir Thomas Sutherland, speaking at a late meeting of the Peninsular and Oriental Steam Navigation Company, stated that the Chinese trade was one of the company's most promising fields of operation, and that they expected to benefit very largely in the near future by the export of frozen Chinese pigs. So far as he was aware, a Chinese pig had never been sent to England yet. It would be interesting to learn under what conditions these frozen pigs are reared. We doubt if a consignment of Chinese pork would sell readily in the Commonwealth.

Answers to Correspondents.

TOMATO BEETLES.

E. ROUND, Wellington Point—

The specimen of tomato plants you forwarded has been handed to the Entomological Department, to be submitted to the Government Entomologist on his return to Brisbane. It would be well to also forward a specimen of the brown beetle you mention.

WOODASH FERTILISATION—CLINICAL THERMOMETER—
SORGHUM POISONING.

P.A.P., Ipswich—

In reply to your questions:—

(a.) The ashes of trees contain comparatively large amounts of mineral plant-food, lime, potash, and phosphoric acid, and the fertilising action of the ash must have produced the heavier crop.

(b.) Hick's $\frac{1}{2}$ -minute clinical thermometer. A little oil should be smeared on the mercury end of it, and the instrument passed into the rectum, where it should remain for about one minute.

(c.) Sorghum poison remains a very short time in the system. The majority of animals affected die, but those that recover may have their systems so reduced as to render them, in rare instances, liable to suffer a relapse if they have been previously affected with redwater. Also, if cattle were so affected about the same time as the feeding on young sorghum took place, the severity of the redwater infection would be increased.

The Markets.

PRICES OF FRUIT—TURBOT-STREET MARKETS.

| Article. | MARCH. |
|---|--------------------|
| | Prices. |
| Apples (Hobart), per case | 6s. to 7s. |
| Apples (Victorian), per case | 6s. to 8s. |
| Apples (Local), per case | 4s. to 6s. |
| Apples (Cooking), per case | 4s. 6d. to 6s. |
| Bananas (Cavendish), per dozen | 1½d. to 2½d. |
| Bananas (sugar), per dozen | 1½d. to 2d. |
| Grapes (Choice), per lb. | 1½d. to 3d. |
| Lemons (Italian), per case | 9s. to 10s. |
| Lemons (Sydney), per case | ... |
| Mangoes, per case | ... |
| Nectarines, per case | ... |
| Passion Fruit, per quarter-case | 2s. to 2s. 6d. |
| Papaw Apples, per quarter-case | ... |
| Peaches, per quarter-case | 2s. 6d. to 4s. |
| Pears, per half-case | 6s. to 8s. |
| Persimmons, per quarter-case | 2s. 6d. to 3s. |
| Pineapples, best rough, per dozen | 1s. to 1s. 6d. |
| Pineapples (Choice), smooth, per dozen | 2s. 6d. to 4s. 6d. |
| Plums, per quarter-case | 5s. |
| Tomatoes, per quarter-case | 1s. 6d. to 2s. |

SOUTHERN FRUIT MARKET.

| | |
|--|--------------------|
| Apples (Local), eating, per case | 7s. to 9s. |
| Apples (Local) cooking, per case | 3s. 6d. to 5s. 6d. |
| Apricots (Tasmanian), per quarter-case | ... |
| Apricots (Choice), per quarter-case | ... |
| Bananas (Queensland), per bunch | 1s. 6d. to 3s. |
| Bananas (Queensland), per case | 7s. to 7s. 6d. |
| Grapes (Queensland), Muscatels, per box | 6s. to 7s. |
| Lemons (Local), per gin case | 8s. to 12s. |
| Lemons (Italian), per half-case | 9s. to 10s. |
| Lemons (Italian), per double case | 21s. to 23s. |
| Mandarins (Emperor), per case | ... |
| Mandarins (medium), per case | ... |
| Mangoes, per case | 2s. to 3s. |
| Nectarines, per half-case | 2s. 6d. to 4s. 6d. |
| Oranges (Choice), per case | 4s. to 5s. |
| Passion Fruit (Choice), per half-case | 3s. to 3s. 6d. |
| Peaches (Slipstones), per half-case | 2s. 6d. to 4s. |
| Pears (Choice), per case | 10s. to 12s. |
| Persimmons, per box | 3s. to 3s. 6d. |
| Pineapples (Queensland), choice, Queens, per case | 3s. to 5s. |
| Pineapples (Queensland), Ripley Queen, per case | 4s. 6d. to 5s. 6d. |
| Pineapples (Queensland), choice common, per case | 3s. 6d. to 4s. 6d. |
| Plums, per half-case | 1s. 6d. to 2s. 6d. |
| Quinces, per gin case | 3s. to 4s. |
| Rock melons (Local), per case | 1s. 6d. to 3s. |
| Rock melons (Queensland), per gin case | 1s. 6d. to 2s. |
| Tomatoes (Local), per half-case | 2s. 6d. to 3s. |
| Water melons (Queensland), choice, per dozen | 3s. 6d. to 6s. |
| Water melons, medium, per dozen | 3s. 6d. to 6s. |

PRICES OF FARM PRODUCE IN THE BRISBANE MARKETS FOR FEBRUARY.

| Article. | | | | | | FEBRUARY. | |
|---------------------|-----|-----|-----|-----|-------|---------------------|--|
| | | | | | | Prices. | |
| Bacon, Pineapple... | ... | ... | ... | ... | lb. | 10d. to 11½d. | |
| Barley, Malting | ... | ... | ... | ... | ton | 3s. 6d. to 3s. 9d. | |
| Bran | ... | ... | ... | ... | ton | £4 15s. | |
| Butter, Factory | ... | ... | ... | ... | lb. | 9½d. | |
| Chaff, Mixed | ... | ... | ... | ... | ton | £5. | |
| Chaff, Oaten | ... | ... | ... | ... | ton | £4 15s. to £5 5s. | |
| Chaff, Lucerne | ... | ... | ... | ... | ton | £5 to £6 | |
| Chaff, Wheaten | ... | ... | ... | ... | ton | £2 15s. to £3 5s. | |
| Cheese | ... | ... | ... | ... | lb. | 6½d. to 7d. | |
| Flour | ... | ... | ... | ... | ton | £10 10s. | |
| Hay, Oaten | ... | ... | ... | ... | ton | £6 to £6 10s. | |
| Hay, Lucerne | ... | ... | ... | ... | ton | £4 to £4 10s. | |
| Honey | ... | ... | ... | ... | lb. | 2d. to 2¼d. | |
| Maize | ... | ... | ... | ... | bush. | 4s. | |
| Oats | ... | ... | ... | ... | ton | ... | |
| Pollard | ... | ... | ... | ... | ton | £5 10s. to £6 10s. | |
| Potatoes | ... | ... | ... | ... | ton | £6 to £6 10s. | |
| Potatoes, Sweet | ... | ... | ... | ... | ton | ... | |
| Pumpkins | ... | ... | ... | ... | ton | ... | |
| Wheat, Milling | ... | ... | ... | ... | bush. | 4s. to 4s. 3d. | |
| Wheat, Chick | ... | ... | ... | ... | ton | 4s. 2d. | |
| Onions | ... | ... | ... | ... | ton | £8 15s. to £9. | |
| Hams | ... | ... | ... | ... | lb. | 1s. to 1s. 1½d. | |
| Eggs | ... | ... | ... | ... | doz. | 10¼d. to 1s. 3d. | |
| Fowls | ... | ... | ... | ... | pair | 2s. 8d. to 4s. | |
| Geese | ... | ... | ... | ... | pair | 7s. to 7s. 3d. | |
| Ducks, English | ... | ... | ... | ... | pair | 2s. 6d. to 3s. 3d. | |
| Ducks, Muscovy | ... | ... | ... | ... | pair | 3s. 7d. to 4s. 10d. | |
| Turkeys (Hens) | ... | ... | ... | ... | pair | 7s. to 8s. | |
| Turkeys (Gobblers) | ... | ... | ... | ... | pair | 10s. to 15s. | |

ENOGGERA SALEYARDS.

| Animal. | | | | | | FEBRUARY. | |
|-------------------|-----|-----|-----|-----|-----|-------------------|--|
| | | | | | | Prices. | |
| Bullocks | ... | ... | ... | ... | ... | £8 7s. 6d. to | |
| „ (single) | ... | ... | ... | ... | ... | £9 2s. 6d. | |
| Cows | ... | ... | ... | ... | ... | £10 2s. 6d. | |
| Merino Wethers | ... | ... | ... | ... | ... | £7 5s. to £8 10s. | |
| Crossbred Wethers | ... | ... | ... | ... | ... | 16s. 9d. | |
| Merino Ewes | ... | ... | ... | ... | ... | 17s. 3d. | |
| Crossbred Ewes | ... | ... | ... | ... | ... | 11s. 3d. | |
| Lambs | ... | ... | ... | ... | ... | 18s. | |
| Pigs (porkers) | ... | ... | ... | ... | ... | 13s. 6d. | |
| „ (slips) | ... | ... | ... | ... | ... | 46s. | |
| | ... | ... | ... | ... | ... | 15s. 6d. | |

Orehard Notes for May.

By ALBERT H. BENSON, M.R.A.C.

THE SOUTHERN COAST DISTRICTS.

The advice that I have given respecting the handling and marketing of citrus fruits in the last two numbers of this Journal apply with equal force to this and the following months. Do not think that you can give the fruit too much care and attention; it is not possible, as the better they are handled, graded, and packed the better they will carry, and the better the price they will realise.

Continue to pay careful attention to specking, and fight the blue mould fungus everywhere. Don't let mouldy fruit lie about on the ground, hang on the trees, or be left in the packing shed, but destroy it by burning. Keep a careful look-out for fruit-fly, and sweat the fruit carefully before packing. If this is done, there will be little fear of the fruit going bad in transit, or being condemned on its arrival at Southern markets. Where the orchard has not been already cleaned up, do so now, and get it in good order for winter. Surface working is all that is required, just sufficient to keep moisture in the soil, keep down undergrowth, and prevent the packing of the surface soil by trampling it down when gathering the fruit.

Keeping the orchard clean in this manner enables any fallen fruit to be easily seen and gathered, and I need hardly state what I have mentioned many times before, that diseased fruit should on no account be allowed to lie about and rot on the ground, as this is one of the most frequent causes of the spreading of many fruit pests.

May is a good month to plant citrus trees, as if the ground is in good order they get established before the winter, and are ready to make a vigorous growth in spring.

Don't plant the trees, however, till the land is ready, as nothing is gained thereby, but very frequently the trees are seriously injured, as they only make a poor start, become stunted in their growth, and are soon overtaken by trees planted later, that are set out under more favourable conditions. The land must be thoroughly sweet, and in a good state of tilth—that is to say, deeply worked, and worked down fine. If this has been done it will probably be moist enough for planting, but should there have been a dry spell, then when the hole has been dug and the tree set therein, and the roots just covered with fine top soil, four to eight gallons of water should be given to each tree, allowed to soak in, and then covered with dry soil to fill up the hole. In sound, free sandy loams, that are naturally scrub, holes may be dug and the trees planted before the whole of the ground is brought into a state of perfect tilth. It is, however, better to do the work prior to planting, as it can then be done in the most thorough manner; but if this is not found possible, then the sooner it is done after planting the better. If the land has been thoroughly prepared, there is no necessity to dig big holes, and in no case should the holes be dug deeper than the surrounding ground either is or is to be worked. The hole need only be big enough to allow the roots to be well spread out, and deep enough to set the tree at the same depth at which it stood when in the nursery. Plant worked trees 24 to 25 ft. apart each way, and seedlings at least 30 ft. apart each way.

Towards the end of the month cover pineapples when there is any danger of frost; dry blady grass or bush hay is the best covering. Keep the pines clean and well worked; first, to retain moisture; and, secondly, to prevent injury from frost; as a patch of weedy pines will get badly frosted when a clean patch alongside will escape without any serious injury.

Slowly-acting manures, such as meatworks' manures, when coarse, boiling-down refuse, farm manures, or composts may be applied during the month, as they will become slowly available for the trees' use when the spring growth takes place, but quickly-acting manures should not be applied now.

THE TROPICAL COAST DISTRICTS.

May is a somewhat slack month for fruit—pines, papaws, and granadilas are not in full fruit, the autumn crop of citrus fruit is over, and the spring crop only half-grown. Watch the young citrus fruit for Maori, and when it makes its appearance spray with the sulphide of soda wash. Keep the orchard clean, as from now till the early summer there will not be much rain, and if the orchard is allowed to run wild—viz., unworked and dirty—it is very apt to dry out, and both the trees and fruit will suffer in consequence.

Bananas should be kept well worked, for this reason, and though the fly should be slackening off, every care must still be taken to prevent any infested fruit being sent to the Southern markets.

Citrus fruits can be planted during the month, the remarks *re* this under the heading of the Southern Coast Districts being equally applicable here.

THE SOUTHERN AND CENTRAL TABLELANDS.

Get land ready for the planting of new deciduous orchards, as although there is no necessity to plant so early, it is always well to have the land in order, so as to be ready to plant at any time that the weather is suitable. The pruning of deciduous trees can commence towards the end of the month in the Stanthorpe district, and be continued during June and July. It is too early for pruning elsewhere, and too early for grapes, as a general rule. Keep the orchard clean, particularly in the drier parts. In the Stanthorpe district I recommend the growing of a crop of blue or grey field peas, or a crop of vetches between the trees in the older orchards, as a green manure. The crop to be grown as a green manure should have the soil well prepared before planting, and should be manured with not less than 4 cwt. of phosphatic manure, such as Thomas's phosphate, or fine bone-dust, per acre. The crop to be ploughed in when in the flowering stage. The granitic soils are naturally deficient in organic matter and nitrogen, as well as phosphoric acid, and this ploughing in of a green crop that has been manured with a phosphate manure will have a marked effect on the soil.

Lemons will be ready for gathering in the Roma, Barcaldine, and other districts. They should be cut from the trees, sweated, and cured down, when they will keep for months, and be equal in quality to the imported Italian or Californian fruit. If allowed to remain on the trees, the fruit becomes over-large and coarse, and is only of value for peel. Only the finest fruit should be cured; the larger fruit, where the skin is thicker, is even better for peel, especially if the skin is bright and free from blemish; scaly fruit, scabby, warty, or otherwise unsightly fruit is not suitable for peel, and trees producing such require cleaning or working over with a better variety, possibly both.

The remarks *re* other citrus fruit and the work of the orchard generally that I made when dealing with the coast districts, apply equally well here, especially as regards handling the crop and keeping down pests.

Farm and Garden Notes for May.

FIELD.—During this month the principal work in the field will be the sowing of wheat, barley, oats, rye, and vetches. There is no time to lose now in this work. Potatoes should be hilled-up. Cut tobacco. The last of the cotton crop should now be picked, the bushes being stripped daily after the dew has evaporated. Growers are notified that cotton-ginning machinery has been installed by Messrs. Kitchen and Sons in the Valley, Brisbane, so that a sure means of disposing of the crop is available (see Journal of 1st March, 1906). Every effort should be made to ensure feed for stock during the winter by utilising all kinds of green fodder, in the form of silage or hay. Those who own dairy stock will be wise to lay down permanent grasses suitable to the climate and to their particular district and soil. A few acres of artificial grass will support a surprisingly large number of cattle or sheep in proportion to acreage. Couch grass in the West, as has been proved at Barcaldine, will carry ten or twelve sheep to the acre. Coffee-picking should now be in full swing, and the berries pulped as they are picked. Strawberries may be transplanted. The best varieties are Pink's Prolific, Aurie, Marguerite, Hautbois, and Trollope's Victoria. The Aurie is the earliest, and the Marguerite next. In some localities, strawberry planting is finished in March, and the plants bear their first fruits in August. In others, fruit may be gathered in July, and the picking does not end until January.

KITCHEN GARDEN.—Onions which have been planted in seed beds may now be transplanted. The ground should have been thoroughly cleaned, pulverised, and rolled previous to transplanting. Onions may still be sown in the open on clean ground. In favourable weather plant out cabbages, cauliflowers, lettuce, leeks, beetroot, endive, &c. Sowings may also be made of all these, as well as of peas, broad beans, kohlrabi, radishes, spinach, turnips, parsnips, and carrots. Dig and prepare beds for asparagus. Full instructions for the successful cultivation of this valuable vegetable will be found in the February issue of the Journal, 1906.

FLOWER GARDEN.—Transplanting and planting may be carried out simultaneously during this month in showery weather; the plants will thus be fully established before the early frosts set in. Camellias and gardenias may be safely transplanted, also such soft-wooded plants as verbenas, petunias, penstemons, &c. Cut back and prune all trees and shrubs ready for digging. Dahlia roots should be taken up and placed in a shady situation out of doors. Plant bulbs, such as anemones, ranunculus, snowflakes, freesias, ixias, iris, narcissus, &c. Tulips and hyacinths may be tried, but success in this climate is very doubtful. All shades and screens may now be removed to enable the plants to get the full benefit of the air. Fork in the mulching, and keep the walks free from weeds. Clip hedges and edgings.

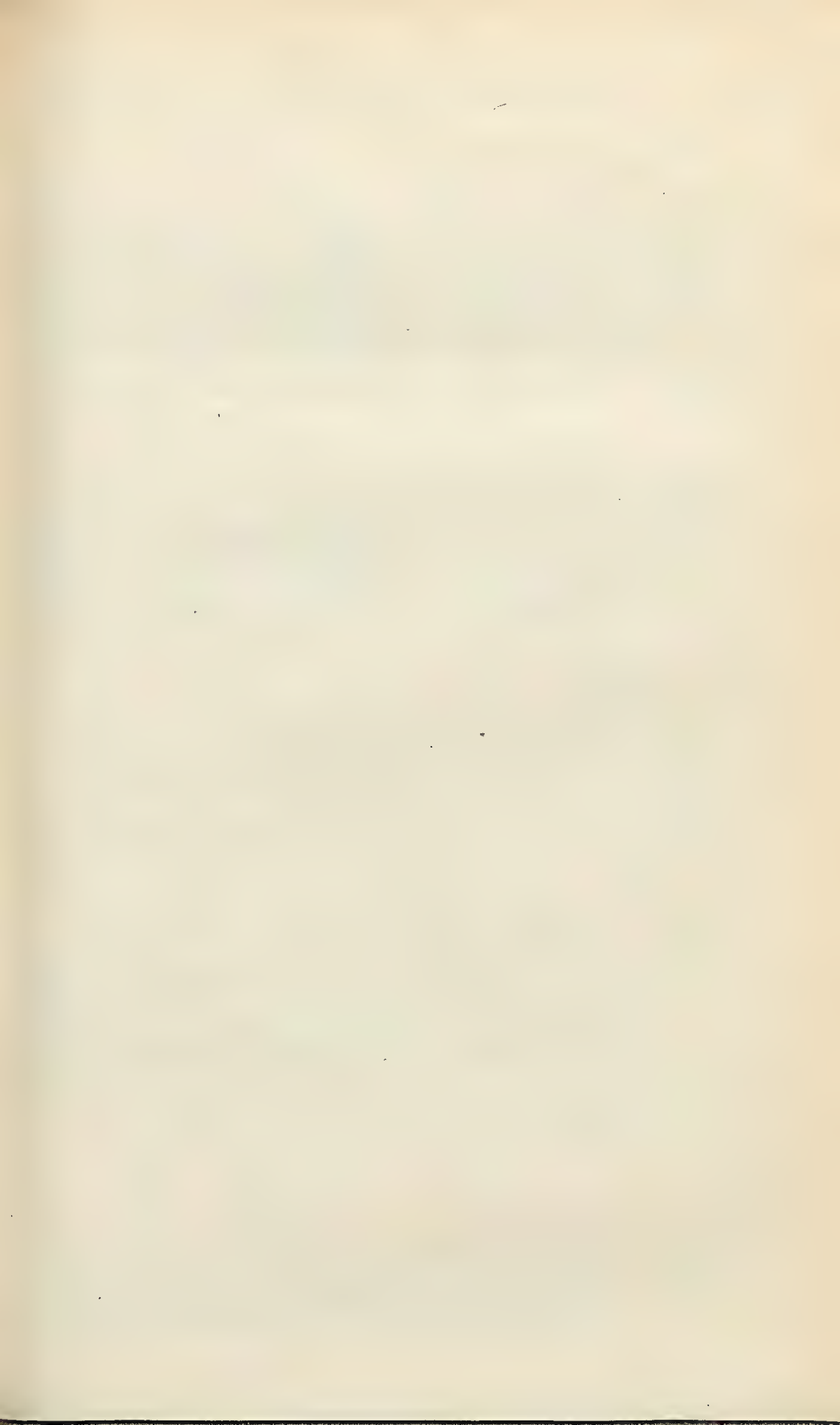

PLANTING SEASONS, &c., IN DIFFERENT PARTS OF THE STATE OF QUEENSLAND.

| Plant. | How to Sow. | SOUTHERN COASTAL DISTRICTS. | | DARLING DOWNS. | | CENTRAL DISTRICTS. | |
|---------------------|-------------|-----------------------------|------------------------------------|---|--------------|------------------------------|--------------|
| | | When to Sow. | Amount of Seed or Plants Required. | When to Sow. | When to Sow. | How to Sow. | When to Sow. |
| FIELD CROPS. | | | | | | | |
| All grasses | D | May to September | ½ to 2 bushels per acre | { European, March to July;
Sub-tropical, Sept. to Feb. | D | September to April | |
| Arowroot | A | August and September | 1,700 to 1,800 plants | August to October | A | August to October | |
| Broom millet | D | September to January | 6 to 8 lb. | September to February | D | August to January | |
| Buckwheat | D | July | 1 to 2 bushels | February and August | D | July to February | |
| Cabbage | B | January to September | 2 to 3 lb. | January to September | B | February to August | |
| Cape barley | D | March to June | 1 to 1½ bushels (D) | February to June | D | March to May | |
| Carrot | D | July (for field) | 3 to 5 lb. | February to August | D | March to June | |
| Chicory | I | July | 3 to 5 lb. | February to August | I | March to June | |
| Clover | D | March and August | 12 to 20 lb. | March to July | D | March to May | |
| Coffee | O | August to November | 1,200 plants | Nil | D | July to November | |
| Cotton | C | August and September | 1,500 plants or 5 lb. seed. | September | T | July to October | |
| Cowpea | P | January and September | 8 lb. | September to January | A | September to February | |
| Field peas | S | April to August | 2 bushels | February and July | P | March to July | |
| Ginger | W | August to October | 1,201 plants | Nil | S | July to October | |
| Henip (sisal) | T | September to March | 680 plants | September to February | C | August to March | |
| Imphee | D | August to January | 10 lb. | September to January | T | August to February | |
| Kafir corn | D | August to January | 10 lb. | September to January | D | August to February | |
| Laceme | D | March to July | 10 to 20 lb. (b. c.) | February to July | D | August to February | |
| Maize | A | August to December | ½ to 3 bushels (b. c.) | Sept. to Nov. & Feb. to April | D | August to March | |
| Mangelwurzel | E | March and April | 5 to 6 lb. | September to December | A | March to May | |
| Melons (water) | H | August to October | 4 to 5 lb. | September to December | E | July to October | |
| Onions | B | March to June | 2 bushels (b. c.) | March and August | H | March to April | |
| Panicum | D | March to May | 20 lb. | March to July | D | March to April | |
| Potatoes | D | July to October | 20 lb. (b. c.) | September to January | N | July to February | |
| Rape | E | February and August | 10 to 14 cwt. | August and February | N | Middle March and middle July | |
| Rice | B or D | September | 2 to 3 lb. | February to May | E | October to April | |
| Rye | E | July | 30 to 40 lb. | February to May | E | October to January | |
| Sorghum | D | March to July | 2 to 3 bushels | February to June | D or B | March and April | |
| Sugar-cane | M | August and September | 10 lb. | September to December | E | August to March | |
| Sweet potatoes | Q | September | 1,700 to 2,000 plants | September to December | D | July to September | |
| Trees | Q | September | 2,420 plants | September to November | M | August to February | |
| Tobacco | B | January, October, November | 10 lb. | Sept., Oct., Nov. | Q | August to January | |
| Tomatoes | B | August and September | 1 teaspoonful per 100 sq. ft. | August and September | D | July to September | |
| Turnips | D | Aug. to Oct., Jan. to March | 1 oz. to 1,500 plants | February to October | B | August to February | |
| Turnips (Swede) | D | February to April | 2 lb. per acre | February to May | D | March to May | |
| Vetches | D | March to June | 1 bushel | Aug. to Oct. & Mar. to May | D | March to May | |
| Wheat | D | March to June | ½ bushel | April to July | D | March to May | |

VEGETABLE GARDEN.

| | | | | | |
|-----------------------|-----------------------------|-----------------------------------|-----------------------------|--------|--------------------------------|
| Artichoke (Globe) | May to September | 5 oz. per perch | March to October | L | November and April |
| Artichoke (Jerusalem) | September | 3 to 4 cwt. per acre | July and August | C | March and August |
| Asparagus | July and August | 1 oz. to 60 ft. of drill | May to August | S | March and April |
| Beans (French) | August to May | 1 qt. to 100 " | August to March | I | Jan. to Apr. and Aug. to Sept. |
| Beans (broad) | March and September | 2 qts. to 100 " | February to July | I | March and April |
| Beans (Lima) | August and November | 1 oz. to 50 ft. of drill | September to December | S or Y | February to August |
| Beetroot | February to September | 5 oz. per perch | January to September | B or S | March to June |
| Cabbage | January to September | 1 oz. to 1,000 plants | All seasons | B | February to June |
| Capsicum and chillies | August to October | 1 oz. per 100 ft. of drill | August to October | F | August to October |
| Carrot | Nearly all seasons | 1,210 plants per acre | August to October | B | March to June |
| Cassava | Middle Jan. to middle Mar. | 5 oz. to 2,000 plants | December to March | B | July to October |
| Cauliflower | January and February | 1 oz. to 2,000 plants | November to January | U | February to June |
| Celery | August or September | Plant whole fruit | August to October | T & Y | March and April |
| Chocoy | August to November | 1 oz. to 125 hills | Aug., Sept., to December | D | March, August, and September |
| Cress | August to November | Division of roots and seed | August to January | H | Nearly all seasons |
| Cucumbers | March to May | 1 oz. to 1,000 plants | March to May | K | March to September |
| Culinary herbs | September | 1 oz. to 3,000 plants | September and October | C | August to October |
| Egg-plant | February and March | 1 qt. of setts to 50 ft. of drill | February and April | K | March to July |
| Endive | Nearly all seasons | 3 to 4 lb. per acre | All seasons | B | February to October |
| Eschallots | Aug., Sept., Feb., April | About 4 lb. per acre | February to June | B | March to May |
| Kohl-rabi | April and May | 1 oz. to 3,000 plants | February to May | B | March to April |
| Leeks | Aug., Sept., Feb., April | 1 oz. to 30 hills | Spring and Autumn | B | Nearly all the year |
| Lettuce | August to November | 1 oz. to 100 hills | Aug. to Nov., July to Mar. | H | July to March (rockmelon) |
| Melons | August to November | 1 plant per sq. yard | Aug. to Jan., July to Mar. | H & C | July to March |
| Marrows | September to November | 1 oz. to 100 ft. of drill | September to November | N or B | August to November |
| Okara | March, April, and May | 1 oz. to 200 " | March to July | D | March to April |
| Onions | March and April | 21,780 plants per acre | February to April | N | March to April |
| Parsnips | September to November | 1 qt. to 75 ft.-of drill | September to November | N | July to September |
| Pea-nuts | January to September | 10 to 14 cwt. per acre | January, March, and June | S | March to June |
| Peas | February and August | 1 oz. to 50 hills | Jan., Feb., Aug., and Sept. | N | Middle Mar. and middle July |
| Potatoes | August to November | 1 plant per sq. yard | September to November | T | July to March |
| Pumpkins | May to August | 1 oz. to 70 ft. of drill | Autumn to August | I | February to June |
| Rhubarb | All seasons | 1 oz. to 100 " | March to August | F | February to November |
| Radish | March to August | 1 oz. to 100 " | March to August | F | March to April |
| Sal-safy | March to May | 1 oz. to 1,500 plants 3 ft apart | August to September | I | March to May |
| Spinach (prickly) | August and September | 1 oz. to 150 ft. of drill | August to December | I | July to September |
| Spinach (round) | August to November | 7,260 plants per acre | February to September | D | July to March |
| Tomatoes | Aug. to Oct. & Jan. to Mar. | | | B & Y | August to October |
| Turnips | | | | D | July to October |
| Turneric | | | | Q | |

PLANTING SEASONS, &c., IN DIFFERENT PARTS OF THE STATE OF QUEENSLAND—continued.

| Plant. | SOUTHERN COASTAL DISTRICTS. | | DARLING DOWNS. | | CENTRAL DISTRICTS. | |
|-------------------|-----------------------------|-------------------------|------------------------------------|-------------------------|--------------------|------------------------|
| | How to Sow. | When to Sow. | Amount of Seed or Plants Required. | When to Sow. | How to Sow. | When to Sow. |
| ORCHARD. | | | | | | |
| Aligator pear | X | December to February | 108 trees per acre | Nil | X | August to February |
| Apple | X | June to August | 108 | May to September | Z | May to August |
| Apricot | X | June to August | 108 | May to September | Z | May to August |
| Banana | V | October to February | 302 | Nil | e | August to February |
| Brazilian cherry | T | May to August | 689 | Nil | c | July, Aug., and Mar. |
| Cape gooseberry | D or I | May | 108 | August to November | p | March to May |
| Cherry | X | June to August | 108 | May to September | X | July, Aug., Jan., Feb. |
| Citrus fruits | X | May to August, February | 108 | February, March, August | f n | July and August |
| Custard apple | J | May to August | 193 | Nil | X | July to October |
| Date | X | July | 69 | Nil | X | May to August |
| Fig | X | August | 193 to 108 | April to September | J | August to October |
| Granadilla | V | September | 302 | Nil | e Y | August to October |
| Grape vines | S | July | 544 | May to September | e | July and August |
| Gooseberries | T | July and August | 689 | April to July | f n | July and August |
| Guava | X | April to August | 108 | Nil | f X | August to October |
| Jack fruit | X | December and February | 108 | Nil | X | August to October |
| Loquat | X | December and February | 108 | May to September | X | August to February |
| Mango | X | December and February | 48 | Nil | T | August to February |
| Monstera Delicost | Z | July to October | 134 | April to September | X | July to October |
| Mulberry | X | July and August | 108 | April to September | Z | May to August |
| Nectarine | X | April to August | 108 | April to September | X | May to August |
| Papaw | T | December and February | 689 | Nil | e | August to February |
| Passion fruit | V | September | 302 | August to September | X I | August to October |
| Peach | X | April to August | 108 | April to September | Z | May to August |
| Pear | X | June to August | 108 | May to September | X | May to August |
| Persimmon | X | May to August | 108 | May to August | X | May to August |
| Pineapple | A | October to December | 1,800 | Nil | p | August to February |
| Plum | X | June to August | 108 | May to September | J | May to August |
| Pomegranate | T | June to August | 689 | May to August | p | May to August |
| Quince | T | June to August | 689 | May to August | e | August to October |
| Raspberry | A | June to August | 1,800 | May to September | e | May to August |
| Rose apple | r | April to August | 170 | Nil | X | August to October |
| Strawberry | I | April to August | 14,000 | February to July | I | March to July |
| | | | | | | Trees per Acre. |
| | | | | | | 48 |
| | | | | | | 134 |
| | | | | | | 134 |
| | | | | | | 435 |
| | | | | | | 435 |
| | | | | | | 1,742 |
| | | | | | | 100 |
| | | | | | | 193 |
| | | | | | | 109 |
| | | | | | | 193 |
| | | | | | | 302 |
| | | | | | | 544 |
| | | | | | | 435 |
| | | | | | | 48 |
| | | | | | | 109 |
| | | | | | | 48 |
| | | | | | | 680 |
| | | | | | | 134 |
| | | | | | | 435 |
| | | | | | | 302 |
| | | | | | | 134 |
| | | | | | | 193 |
| | | | | | | 193 |
| | | | | | | 2,722 |
| | | | | | | 193 |
| | | | | | | 435 |
| | | | | | | 435 |
| | | | | | | 109 |
| | | | | | | 21,780 |

NORTHERN DISTRICTS (TROPICAL PRODUCTS).

| Plant. | How to Sow. | When to Sow. | Amount of Seed or Plants Required. |
|------------------------------------|-------------|------------------------------|---|
| FIELD CROPS. | | | |
| Arrowroot | Ct | August to October | 4,000 setts per acre |
| Cassava | ct | All seasons | 1,400 plants .. |
| Castor oil | Ad | Aug. to Nov., Mar. and April | 25 lb. seed .. |
| Cotton (annual) | Cd | Aug. to Sep., Mar. and April | 4,000 plants .. |
| Cotton (perennial) | a | | 880 plants .. |
| Cowpea | P | Sept., Oct., Jan. to March | 12 lb. seed .. |
| Ginger | Nt | August to November | 15,000 setts .. |
| Jalap | Nt | " " | 15,000 setts .. |
| Maize | o | September to January | $\frac{1}{4}$ to $\frac{1}{2}$ bushel drilled, $1\frac{1}{2}$ bushels broadcast |
| Panicum | D or P | September to December | $\frac{1}{2}$ bushel seed per acre |
| Pineapples | Jo | February and August | 3,600 plants .. |
| Pigeon pea | Cd | Aug. to Nov., Mar. and April | 20 lb. seed .. |
| Peanuts | Pt | Oct. to Dec., Mar. and April | 2 bushels .. |
| Rice | B or D | December and January | 1 to $1\frac{1}{2}$ bushels .. |
| Sorghum | D or P | October to March | $\frac{1}{2}$ bushel seed .. |
| Sunflower | C | Aug. to Oct., Jan. to March | $\frac{1}{2}$ bushel seed .. |
| Sessamum | S | " " | 5 lb. seed .. |
| Sugar-cane | M | August to October | 4,000 to 5,000 plants .. |
| Teasinte | D or P | October to March | $\frac{1}{2}$ bushel seed .. |
| Tobacco, sow | B | October to November | 1 teaspoonful per 100 sq. ft. |
| Tobacco (cigar leaf), plant | b | December to January | 7,500 plants per acre |
| Turmeric | Nt | August to November | 15,000 setts .. |

PLANTATION CROPS.

| | | | |
|----------------------------|--------|---------------------------------|--------------------------|
| Allspice | fX | Sept., Oct., Feb. to April ... | 108 plants per acre |
| Bananas | V | October to February | 300 " " |
| Cardamoms | lT | December to March | 680 " " |
| Camphor | fj | Sept., Oct., Feb. to April ... | 200 " " |
| Cinnamon | fX | " " | 108 " " |
| Cloves | fXl | " " | 108 " " |
| Cocanut | X | September or March | 48 " " |
| Cocoa | fjl | Sept., Oct., Feb. to April ... | 200 " " |
| Copal gum | fX | " " " " | 108 " " |
| Coffee, sow | f | May to June | 1 lb. seed to 25 sq. ft. |
| Coffee, Arabian, plant out | a | Sept., Oct., Feb. to April ... | 881 plants per acre |
| Coffee, Liberian, " " | T or n | " " " " | 680 " " |
| Cubebs | kl | " " " " | 800 " " |
| Divi-divi | fX | " " " " | 108 " " |
| Fibres— | | | |
| Agaves (sisal) | T | September to March | 680 plants per acre |
| Murva | A | " " " " | 1,700 " " |
| Manila | c | November to March | 435 " " |
| Ramie | A | Sept., Oct., Jan. and Feb. ... | 1,700 " " |
| Kapock | fX | September or March | 50 " " |
| Kolanut | fX | Sept., Oct., Feb. and March ... | 108 " " |
| Nutmegs | fX | Sept., Oct., Feb. to April ... | 108 " " |
| Oil palm | fX | " " " " | 50 " " |
| Pepper | kl | " " " " | 800 " " |
| Plantain | V | October to February | 300 " " |
| Rubber, sow | f | Within 20 days of harvesting | |
| Para | j or X | September or March | 50 to 200 " " |
| Ceara | Xgd | September to March | 108 " " |
| Rambong | hi | " " " " | 27 " " |
| African | j or X | " or " " " | 100 to 200 " " |
| Castilloa | j or X | " " " " | 100 to 200 " " |
| Sago palm | fX | Sept., Oct., Feb. to April ... | 50 " " |
| Tea | fA | " " " " | 1,500 " " |
| Vanilla | kl | " " " " | 800 " " |

NORTHERN DISTRICTS (TROPICAL PRODUCTS)—*continued.*

| Plant. | How to Sow. | When to Sow. | Amount of Seed or Plants Required. |
|-----------------------------------|-------------|----------------------------|------------------------------------|
| VEGETABLE GARDEN. | | | |
| Beans—Lima, Tonga, Mauritius, &c. | Y m | August to November ... | 1 lb. seed to 100 plants |
| Chocos | Y | August to Nov., and May... | Plant whole fruit |
| Cucumbers | H or Y | " | 1 oz. seed to 100 plants |
| Egg plant | B C | " | 1 " 1,000 " |
| Okra | B P | " | 1 " 200 " |
| Pumpkins | T | " | 1 " 50 " |
| Rosella | B A | " and May... | 1 " 250 " |
| Tomatoes | B Y | " | 1 " 1,500 " |
| Yams | A m t | September and October ... | 50 setts per perch |
| Melons | H | September to November ... | 1 oz. to 25 holes |

ORCHARD.

| | | | | |
|----------------------------|-----------|------------------------------|-----------|----------------|
| Avocado pear | f j | Sept. to Nov., Feb. and Mar. | 200 | trees per acre |
| Anise | f n | Sept. to Nov., Feb. and Apr. | 435 | " " |
| Algoraba bean | f X | Sept. to Nov., Jan. to Mar. | 108 | " " |
| Arnatto | A | Sept. to Nov., Feb. to Apr. | 1,700 | " " |
| Bullock's heart | f j | " " | 200 | " " |
| Bael fruit | f j | " " | 200 | " " |
| Bread fruit | f X | " " | 108 | " " |
| Citrus fruits | f X | " Feb. to Mar. | 108 | " " |
| Custard apple | f n | " " | 435 | " " |
| Carob bean | f X | " Feb. to Apr. | 108 | " " |
| Cocoa | f j l | " " | 680 | " " |
| Cassia bean | f X | " Jan. to Mar. | 108 | " " |
| Cherimoya | f n | " " | 435 | " " |
| Fiji almond | f o r g X | " Feb. to Apr. | 50 | " " |
| Granadilla | Y | " " | 400 | " " |
| Guava | m | " " | 435 | " " |
| Gwango | j X | " Jan. to Mar. | 50 | " " |
| Horse-radish tree | f X | " Feb. to Apr. | 108 | " " |
| Jack fruit | f X | " " | 50 | " " |
| Kei apple | f j | " " | 108 | " " |
| Loquat | f X | " " | 108 | " " |
| Litchi | f X | " " | 50 | " " |
| Longan | f X | " " | 50 | " " |
| Mango | f o r g X | " " | 50 | " " |
| Mulberry | h X | " " | 108 | " " |
| Mangosteen | f j | " " | 200 | " " |
| Mate tea | h X | " Jan. to Mar. | 108 | " " |
| Madagascar plum | f X | " Feb. to Apr. | 50 | " " |
| Natal plum | h n | " " | 435 | " " |
| Papaw | f o r g T | " " | 680 | " " |
| Passion fruit | Y | " " | 302 | " " |
| Pomegranate | f n | June to Sept. | 435 | " " |
| Queensland nut | f X | " " | 108 | " " |
| Rose apple | f j | Sept. to Nov. | 200 | " " |
| Sour sop | f n | " " | 435 | " " |
| Star apple | f X | " " | 108 | " " |
| Tamarind | f X | " " | 108 | " " |
| Vi apple | f X | " " | 50 | " " |
| Whampee | f j | " " | 200 | " " |
| Whang-wee nut | f j | " Jan. to Mar. | 200 | " " |
| Yung-tau, or five corner | f j | " Feb. to Apr. | 200 | " " |
| Bamboo | h X | " Jan. to Mar. | 108 | " " |
| Shade and ornamental trees | f X or i | " Jan. to Apr. | 27 to 108 | " " |
| Timber trees | f X or i | " " | 27 to 108 | " " |

EXPLANATION OF SIGNS USED IN THE ABOVE TABLES.

- A—In rows 5 feet or 6 feet by 4 feet.
 B—Sow in beds, and transplant.
 C—In rows, 4 feet apart by $2\frac{1}{2}$ to 3 feet in the row.
 D—Sow broadcast or in drills.
 E—In drills 3 feet apart. Thin out to 6 inches apart in the row.
 F—In drills and thin out when strong enough.
 G—Sow in beds and transplant to a nursery. When 15 inches high, transplant permanently in rows 6 feet each way.
 H—In holes, 6 feet square; three seeds in a hole.
 I—In drills 2 feet 6 inches apart. The setts 12 inches apart in the rows.
 J—By suckers, and, if suckers are unobtainable, by tops.
 K—In beds 6 inches apart.
 L—Drills 3 feet apart each way.
 M—By tops, if procurable, each with 4 buds, in a furrow, 1 foot deep. Cover with 1 inch of soil. The sett must be laid with the buds on each side. Fill in the furrow as the shoots grow. If tops cannot be got, make setts of the cane itself, each sett with four buds.
 N—In drills 2 feet 6 inches apart. Setts 12 inches in the row.
 O—In rows 6 feet apart, or sow in drills and thin out to 3 feet.
 P—In drills 3 feet apart. Thin out to 1 foot in the rows.
 Q—By suckers or runners, 3 feet apart and 18 inches in the rows.
 R—By runners, $3\frac{1}{2}$ feet by 15 inches.
 S—In rows 2 feet apart and 6 to 8 inches in the rows.
 T—8 feet apart in rows.
 U—Sow in beds. Plant out in a small bed, 3 inches apart. When the plants are strong enough, plant out in trenches, well manured, and fill up as the plants grow above the trench.
 V—By suckers 12 feet apart.
 W—By cuttings or rooted plants, 6 feet in the rows, 6 feet apart.
 X—20 by 20, or 30 by 30.
 Y—On trellis, shed, fence, or wall.
 Y1—On trellis, shed, fence, or wall, 12 feet apart.
 Z—18 feet apart each way.

EXTRA SIGNS USED IN THE TABLES OF TROPICAL AGRICULTURE.

- a*—7 feet apart in lines on the square or diagonal.
b—Rows 3 feet 6 inches apart and the plants 18 to 22 inches apart in the rows.
c—Cuttings 9 to 18 inches long, set on the slope, with about 3 inches above ground, at distances of 5 by 5, 6 by 5, or 6 by 6 feet.
d—Three seeds in a hill or hole; subsequently thin out in favour of the strongest one.
e—By suckers 10 feet apart.
f—Sow in nursery beds and transplant into pits not less than 15 inches cube, in the field or orchard, when 12 to 18 inches high.
g—Sow the seed at the stake where the trees are to remain.
h—By plants or cuttings.
i—40 by 40 feet apart, or at greater distances.
j—15 by 15 feet apart in lines.
k—Plant cuttings against living trees or artificial supports on which the vines can subsequently grow.
l—Under permanent shade.
m—Stakes required for climber.
n—10 by 10 feet apart.
o—In rows 6 feet apart, 2 feet apart in the rows.
p—5 feet apart.
q—25 feet apart.
r—16 feet apart.
s—8 feet by 10 feet.
t—Trenched, well dug, or naturally loose ground necessary.

Agriculture.

DISTRIBUTION OF IMPROVED SEED WHEAT.

The following Bulletin has lately been issued by the Director of the Kansas State Agricultural College, U.S.A. :—

During the past 8 years hundreds of samples of wheat, secured from all parts of the world, have been planted and tested by the Experiment Station at Manhattan, Fort Hays, and McPherson. It has been the practice during the past 5 years, as soon as seed of these varieties were shown to be superior, to distribute it among the farmers in the State.

On account of its general adaptation, hardiness, and good producing qualities, as well as its excellent flour-making and bread-making qualities, the Kharkof variety has been chosen as one of the best varieties for general distribution, and it has been distributed in larger quantities.

The Kharkof wheat was imported from Russia by Prof. M. A. Carleton, Cerealist, U.S. Department of Agriculture. At the Manhattan Station the Kharkof wheat ranks first in average yield for 5 years, 1904-1908. It is also among the highest producers at the Fort Hays and McPherson Stations. Farmers from all over the State are reporting very favourably on the hardiness and productiveness of this variety. Among more than 100 reports received from growers who had secured seed from Manhattan, only two reported unfavourably, and one of these was located in South-eastern Kansas, really the soft wheat section of the State.

The Kharkof has also been shown to have excellent milling qualities, ranking with the best samples of other Turkey wheat more recently imported. Large quantities of the seed of this excellent wheat and smaller quantities of seed of other good producing varieties have been distributed to every county in the State.

There were 3,995 bushels distributed to 638 farmers in 99 counties from the Manhattan Station alone. The Fort Hays Station has distributed 3,980 bushels, mostly Kharkof, to 563 purchasers, mainly in the western counties of the State, and the McPherson Station has distributed small quantities of seed of some of the best producing varieties of hard red winter wheat.

Of the 1,200 farmers receiving the seed from the Experiment Station, probably two-thirds have continued the seed distribution work. The Agronomy Department has encouraged this by asking for reports and listing the growers for reference to those who make inquiry. In 1908 some fifty growers were listed as having some 20,000 bushels of this seed wheat for sale. This list was published and widely distributed through the work of the Farmers' Institute and the Agronomy Departments of this College. Many growers reported that their wheat had all been spoken for by their neighbours; others stated that they would need all the seed that they had produced for their own use.

Considering the facts stated above, it is believed to be a conservative estimate to assume that at least 160,000 acres of the Kharkof and other improved varieties of wheat are now growing in this State. At the rate of 25 bushels per acre, a 4,000,000-bushel crop of this improved wheat will be harvested next season, or enough seed, if carefully distributed, to plant one-half the total wheat acreage of the State.

Little of this improved wheat has, as yet, come to the mills, since it has been used largely for seeding purposes, but by the fall of 1910 it will come to the mills in a large quantity, and the problem of seed-wheat improvement in Kansas will have been solved.

The production by breeding and selection of varieties which are much superior even to the best samples which we are now able to grow and distribute is in active progress.

Of the hundreds of varieties of imported wheat tested at the several Experiment Stations of this State, comparatively few have proven superior. The Kharkof wheat grown in the State to-day is better than the original sample, being both purer and of better quality and of greater yielding capacity.

A. M. TENEYCK, Agronomist.

MAIZE CULTURE.

Maize is more extensively grown in Queensland than any other cereal, the acreage being almost double that of wheat, and the product five times greater. There is, probably, no portion of the State where maize cannot be grown profitably, and that under the most varying conditions of soil and climate. Even on poor, thin soils, if they are properly prepared and cultivated, payable crops are produced, and this is mainly owing to the strong root system of the plant. Experiments have shown that the roots will strike downwards as far as 8 ft., yet the main bulk of the roots generally develop at a depth of 8 in. In experiments made in the United States, it was found that a dense network of feeding roots, reaching from row to row, completely permeated the whole soil area below the cultivated portion, and that the fourth inch of soil contains a larger amount of roots than the 3 in. above it, or the 4 in. below it, and nearly as much as both together.

The essential thing in the cultivation of maize is to keep the soil free from weeds, and covered with a soft soil mulch. There are some who advocate deep cultivation, but the results of fifty-six tests at seventeen Agricultural Experiment Stations in America have shown an average increase of 42 per cent. resulting from shallow cultivation as compared with deep cultivation. It has long since been determined that cultivation conserves soil moisture, and makes the ground warmer. At the Wisconsin Station cultivation 3 in. deep left the ground more moist below the cultivated layer than cultivation 1½ in. deep. If the methods of maize cultivation are based on the root development, it would seem that level cultivation 2 in. to 3 in. deep is most logical.

Maize succeeds best in Queensland on deep, well-drained, loamy soils, such as are to be found on our river flats, and on the volcanic soils of the West, and on the rich alluvial soils of the scrubs. The pioneer maize-growers grew splendid crops of "corn," as maize is universally called, on the newly-cleared scrub soils by very primitive means, and to the present day the same means have to be adopted on such lands, covered as they are for the first three years with innumerable stumps, and permeated by a net-work of roots. Here corn must be planted by means of the hoe, three or four seeds being dropped into a hole and covered by a backward stroke of the hoe. No after cultivation is possible, nor is it needed. During the first season, after the scrub has been burnt off, there are few weeds to trouble the crop, which grows with surprising rapidity, and gives heavy returns. But as soon as the land is clear of stumps, it is necessary to go in for improved implements and methods of cultivation.

SELECTION OF SEED.

Too much care cannot be taken in the selection of seed. It is courting disaster to take seed indiscriminately from a bag. It should be only taken from the very best cobs, and from these the top and bottom ends should be discarded, and only the large, even seeds from the middle selected. After being sown the seed is often destroyed to some extent by bandicoots, but the depredations of these animals can be guarded against by soaking the seeds in tar.

Plate XXVIII.



ROOT DEVELOPMENT—FORTY-FOUR DAYS AFTER PLANTING.

Plate XXIX.



MAIZE FROM WESTBROOK STATE FARM.





1. SPACE BETWEEN ROWS :
 (a) Narrow ;
 (b) Medium ;
 (c) Wide space.

2. SHAPE OF EARS :
 (a) Cylindrical—proper shape ;
 (b) Partly cylindrical ;
 (c) Very tapering.

3. DIRECTION OF ROWS OF KERNELS :
 (a) Straight rows ;
 (b) Rows turn to right ;
 (c) Rows turn to left.

Plate XXXI.



1. UNIFORM SAMPLE—

- (a) Too short for circumference.
- (b) Nearly correct length and circumference.
- (c) Immature.

2. BUTTS, TIPS, SIZE OF COB, DEPTH OF KERNEL, AND SHAPE OF EARS.

Plate XXXII.



1. LENGTH OF EAR—

- (a) Proper length and size.
- (b) Too long.
- (c) Too short.

2. CIRCUMFERENCE OF EAR—

- (a) Well-proportioned, proper circumference.
- (b) Too large for length.
- (c) Too small for length.



The variety to grow largely depends on the local rainfall, the soil and situation, and the time the crop takes to mature. The lateness or earliness of the local season must also be taken into account in choosing a variety, as the time it takes to mature will depend somewhat on these circumstances. In districts close to the coast, where there is a good rainfall and a rich soil, a large type of corn is most likely to prove successful and give a heavier crop. Typical of this class is the Hawkesbury Champion and Clarence River. Once away from the coastal district and the rich scrub lands, the seasons generally experienced demand a variety which will mature its grain quickly. Probably no better type of maize for this purpose than the Leaming may be found.

This earliness of maturing can only be obtained by selection in the field. The average farmer can improve the yield by choosing the finest cobs in his crop, especially those which show the largest number of rows, evenness of the rows, with the least space between them. These characteristics will, however, eventually be lost on the average farm, for the general farmer will never breed corn. Corn-breeding is a special industry in America, as it should also be here, and, when special varieties are wanted, adapted to any particular conditions of soil and climate, these strains must be obtained from the breeder. As a rule, the very best seed will not remain pure for more than four or five years. It then becomes necessary to again secure well-bred seed. The advantages of improved seed corn are numerous. For instance, improved corn tends to diminish the percentage of barren stalks, a most important matter, because such stalks represent a direct loss to the farmer. Statistics have proved that loss from this cause amounts to from 10 to 15 per cent. Again, in the average field, the ears of corn are not uniform in size, many being small and stunted, with few rows of kernels, and those wide apart. It is the province of the corn-breeder to increase the uniformity of the crop, to regulate the proportion of corn to cob, to fill out the ends, and increase the number of large kernels, all of which matters the general farmer has no leisure to attend to.

PREPARATION OF THE LAND.

The success of a corn crop depends largely on the proper preparation of the land, and few plants are more responsive to proper tillage. I have already shown how deeply the roots of the maize plant penetrate the soil. This, then, points to the advisability of not only ploughing the soil to a depth of 9 in. or 10 in., but also of sub-soiling down to 18 in. or 20 in., although the latter operation may not pay in the first season, but certainly would in two or three successive seasons.

The ground having been thoroughly well ploughed in autumn should be left to lie fallow during the winter, exposed to the influence of the air, sun, rain, and frost. Then, in the spring, say about the end of August, it should be either cross-ploughed and well pulverised with a strong cultivator, set first to 8 in., and then crosswise to 10 in. or 12 in. deep. The main thing before planting is to secure a perfect tilth.

PLANTING.

Planting may be begun in the South as soon as the frosts are over. In normal seasons that will be in September, but late frosts frequently occur in October. Fortunately, maize may be planted from September to January, so that, even if the first young crop is damaged by frost, a second can be at once planted, at the cost, however, of labour and lost time. Farther north, where frosts do not occur, the planting season is more extended, but generally the crop should be planted during the five months from September to January. A good plan is to plant one field in September, another in October, and then wait till the end of November to begin to plant the late crop. In that way one is fairly sure of a crop every year on at least two-thirds of the planted ground.

The seed may be drilled in or dropped by hand. The rows are first marked out by a simple home-made corn-marker.

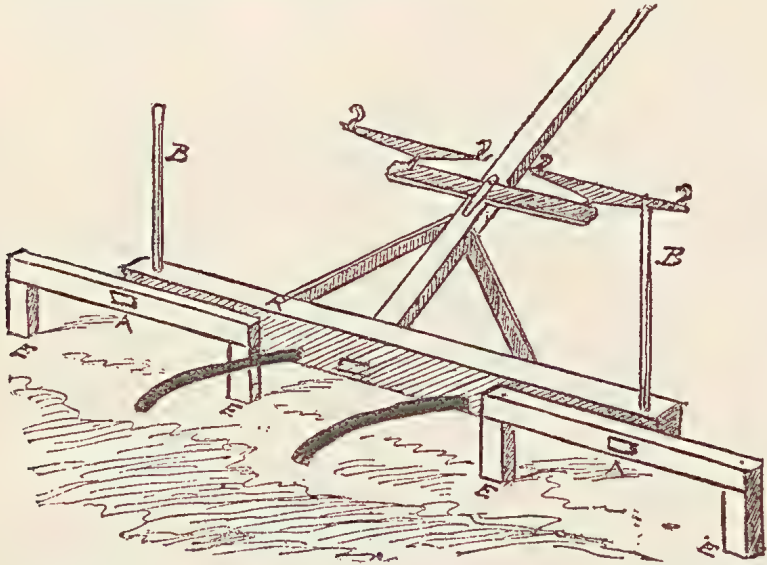

To obtain the best results, the rows should be 4 ft. apart, and the plants 12 in. to 15 in. apart in the rows for small varieties, and 5 ft. apart and 18 in. in the rows for the tall-growing sorts.

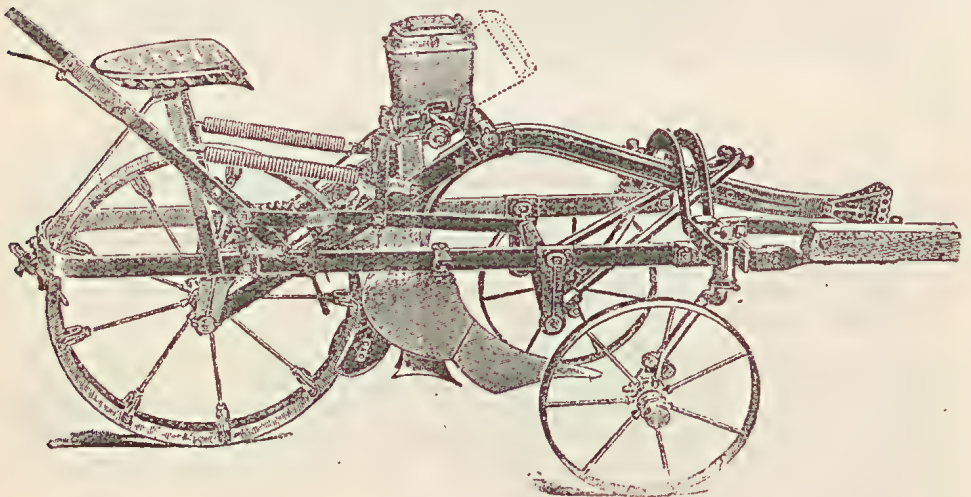

When planting maize, it is customary to also plant in the same field pumpkins in every fourth or fifth row, and the combination of the two crops is very successful and profitable. There is plenty of time to till the land and keep the weeds in check before the pumpkin vines begin to run. Then, when they do this, they cover the soil, stop the growth of weeds, and keep the soil cool and moist during the great heat of summer. Finally, when the corn is harvested, the ground is covered with a vast number of pumpkins, valuable as food for stock, and generally saleable at a good price. For after cultivation, before the pumpkin vines cover the ground, there is nothing equal to a careful and thorough harrowing by means of lever harrows, with the teeth slightly standing backward. If this work is properly done, not one plant in a thousand will be injured, and all the rest will be greatly benefited. The thorough

pulverisation of the soil at the young stems will facilitate the formation of roots, give increased circulation to them, and consequently quick, vigorous growth. Never be afraid to run the harrows over the young seedling corn. Later on, scarifiers may be used, but only at shallow depths, as previously stated. Now the crop may be left to itself.

When the cob has properly formed, it is sometimes customary to cut off the tops of the plants above the cobs, and utilise them as fodder, but it is questionable whether the amount of fodder thus obtained is worth the expense of cutting it.

HARVESTING.

In the United States, maize is harvested in a far different manner to the Queensland practice. There the crop is harvested for both grain and stover. Here we allow the crop to get thoroughly matured and dry. Then the cobs are pulled off by hand and carted to the barn, after which the dry stalks are hoed down and burnt. In America the corn is cut before the ears are thoroughly ripened, or soon after the kernels are well dented. The crop is cut by means of a machine drawn by two horses close to the ground by a combination of the knives. The machine ties the stalks in sheaves, which are then stooked in the field and left until stalks and cobs are thoroughly dry. Then the whole is carted to the barn-yard, the cobs are removed, and the sheaves stacked for fodder.

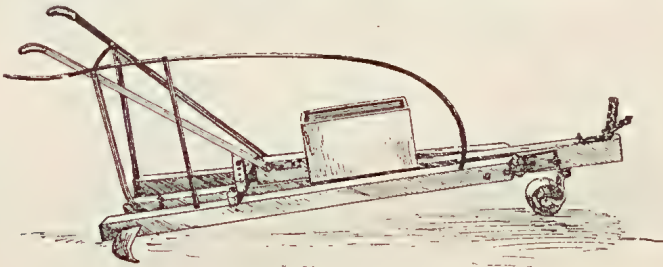

As soon as the cobs are thoroughly dry, they are husked and put through a corn-sheller, which strips off the grain. There are machines which husk and shell in one operation, thus saving an immense amount of hand labour, but, strange to say, they are not universally used in Queensland.

Like all other plants, maize is subject to the attacks of insect and fungoid pests. The boll-worm, which also attacks cotton, is especially injurious. The caterpillars enter the silk end of the corn and live upon the kernels. The only remedies suggested are hand-picking and catching moths by lantern traps, or by poisoned baits. The weevil attacks the dry grain in the barn. One method of destroying it is to place a piece of rag impregnated with a small quantity of bisulphide of carbon on top of the corn in the bags. Bisulphide is poisonous and highly inflammable; it should, therefore, not be inhaled, and no candle or other light should be allowed near it. The grain may also be preserved in air-tight tanks. Before soldering or puttying the tank air-tight, a burning candle is placed in it. By its combustion it will use up in a few minutes all the oxygen of the tank, replacing it by carbonic acid gas. The candle will die out, and the air of the tank will be unfit for any living animal.

LISTING MAIZE.

There is a method of planting maize in the drier prairie States of America, particularly Kansas, Nebraska, and Iowa, known as "listing." The chief implement employed is a double mould-board plough, called a lister. It is worked usually by three horses, and throws the earth equally to the right and left. The implement generally has a subsoil attachment, a corn drill, and a contrivance for covering the seed. The lister cannot be used on unbroken sod

land, but it may be used on other land without previous ploughing, usually without. It simply strikes out furrows 4 ft. apart at the usual depth of ploughing, say 6 in., and the soil thrown right and left covers the intervening unploughed space with fresh earth. At the same time, the implement breaks up the subsoil and plants and covers the grain. The great advantage from a labour-saving standpoint of doing all the work of ploughing, subsoiling, planting, and covering the seed at one and the same operation, is apparent. The following rough sketch of a field in cross-section will make clear the condition of the listed field after the plants are well up from the ground:—



The subsequent treatment of the field planted as above does not differ materially from that given the crop as ordinarily planted. Afterwards the common two-horse cultivator is used, at first with a V-shaped box (A) about 3 ft. long, made of 2-in. plank, which moves with the implement, between the two cultivators, and prevents the earth as it falls into the furrow from covering the young plants. Before the field is "laid by" it is as level as though the grain had been planted on the surface. This method is best adapted to level black soil lands.

The advantages of listing are:—(1) Listed corn, having its roots in the deeper under-soil, is not so affected by drought as that which is surface planted; (2) the cost of growing the plant is reduced by one-fourth to one-third; and (3) the listed field gives a larger yield than that obtained by the common methods of planting.

COST OF GROWING MAIZE.

Mr. W. D. Lamb, of Yangan, an experienced maize-grower, sets down the cost of growing 1 acre of maize, yielding a 40-bushel crop, as follows:—

| | Dr. | £ s. d. |
|--|--------|---------|
| Rent of land | | 0 10 0 |
| First ploughing | | 0 4 0 |
| Second ploughing | | 0 3 0 |
| Harrowing | | 0 1 0 |
| Planting | | 0 1 6 |
| Harrowing twice, at 9d. | | 0 1 6 |
| Disc harrowing twice | | 0 2 0 |
| Pulling maize | | 0 3 0 |
| Carting maize | | 0 2 6 |
| Husking and threshing 40 bush. at 1½d. per bush. | | 0 5 0 |
| Drawing to rail | | 0 3 6 |
| Ten bags at 5d. each | | 0 4 2 |
| Seed maize | | 0 0 6 |
| Balance | | 2 8 4 |

£4 10 0

Cr.

By 40 bushels maize, at 2s. 3d. per bushel . . . £4 10 0

This estimate is, of course, subject to modification, as the price of maize fluctuates with the supply. At the present time of writing maize is worth 4s. per bushel; at the same time, farm wages have been considerably raised of

late, both of which are factors in increasing the cost of production, and in increasing the monetary return. Again, improved methods of cultivation have raised the yield of grain per acre, and although statistical returns may show an average yield of 20 bushels per acre, yet 50, 60, and 80 bushels are frequently obtained in many parts of the State.

CORN STOVER.

Australian farmers are too apt to grow maize for grain only. If the grain, owing to dry weather, or from some other cause, at tasselling time, does not form, or is pinched, they are content in many cases to let their crops go to waste. This is utterly wrong, especially since the advent of the silo. Fodder in the shape of stover—that is, the ripened or nearly ripened maize stalks—appears to be generally neglected, the reason being that farmers differ in their opinions as to the feeding value of the stalks. Some maintain that they are absolutely valueless, and that the best use that can be made of them is to burn them in the field. Others admit that they have about one-half the feeding value of hay. The fact is, that the feeding value of stover depends upon its condition when cut, the quantity fed, and the method of feeding, whether alone or in combination with other forage. A large number of analyses of corn-stover have been made, and experiments in feeding dairy stock have shown that stover rations have produced nearly or the same quantity of milk as the hay ration, the stover being equal in feeding value to oaten straw. As a matter of fact, stover should not be fed alone, but in combination with some other feed, forming what is known as a balanced ration. Alone, it lacks the sweet smell and flavour of hay; it is also hard, and tends to make the mouths of the cattle sore; for this reason they soon reject it. The proper plan is to chaff it, damp it, and mix it with other fodder, when the whole will be consumed by any stock. To secure good stover, allow the corn to stand in the field till the grain begins to harden and the bottom leaves are turning yellow. Then cut it and place in shocks of medium size, and let it dry out thoroughly. This will take about 5 or 6 weeks. After that it can be placed in a stack or rick. Running the crop through a husker and shredder is an ideal way of taking care of corn fodder.

CORN STOVER IN THE SILO.

We rarely hear of a maize-grower in Queensland harvesting his grain and then ensiling the dry stover. Some excellent samples of stover silage have been made at the State Farm at Hermitage. This was exhibited at Bowen Park Exhibition in 1903, and the farmers thought highly of it, but being averse to experimenting, the lesson was lost on the majority.

HOW MUCH WILL CORN SHRINK?

All farmers are aware that the longer they keep their corn the lighter it will get, and hence it is to their advantage to get rid of the new crop as quickly as possible, unless in the face of a rising market. Some years ago an experiment was made by Professor Atkinson at the Iowa (U.S.A.) Experiment Station to ascertain the amount of moisture contained in a cob of corn. A crib was constructed upon the platform of a pair of scales. Seven thousand pounds of corn were husked and placed in the crib. Once each week for a year it was weighed. During the first 3 months the loss was 630 lb., or 9 per cent. of the original weight. During the next 3 months the loss was 390 lb., or 5 per cent. of the original weight. During the next 3 months the loss was 220 lb. And the last 3 showed a further loss of 190 lb. The loss during the year was 1,430 lb., or a trifle more than 20 per cent. This means that a bushel of corn weighing 80 lb. when husked will weigh 64 lb. at the end of the year. The general rule for estimating the shrinkage of maize was to put the loss at from 7 to 8 per cent. From an experiment, however, made by a most methodical farmer in the United States, a new light is thrown on the subject. He weighed one crib of corn when he put it up. The first load was cribbed on the 9th

October, and the last on the 22nd October. The total amount of corn cribbed was 34,970 lb. The first load was hauled out on the 8th January, and the last on the 1st of February. The total hauled out was 29,995 lb., showing a shrinkage of 4,995 lb., or 14 per cent. It would be interesting if such experiments were made by practical men in Queensland. The climatic conditions being somewhat different here to those of parts of the United States, it might be shown that a lesser, or possibly a greater, shrinkage would be shown.

GROWING MAIZE FOR ENSILAGE.

Maize intended for silage should be planted in drills 4 ft. apart, and the plants 15 in. apart in the rows. Allow the maize to cob, and when the kernels have reached the "glazed" stage cut for the silo. By putting it away too young, and before the plants have copped, the silage will be bad, and the silos filled with some tons of matter containing no nutriment, such as water, &c. The amount of fodder per acre, if harvested at the proper stage, will amount to from 10 to 15 tons.

MAIZE ACREAGES FOR VARIOUS SILOS.

In reply to a question as to what is the estimated size of silo needed, and the number of acres of maize required for a given number of cows, for a feeding season of 180 days, a member of the Kansas Dairymen's Association said:—

I have arranged the figures in the following table:—

| No. of Cows. | Estimated Consumption of Silage Tons. | Size of Silo Needed. Diam. Height. | Average Acres Maize Needed. |
|--------------|---------------------------------------|---|-----------------------------|
| 6 | 20 | 9 x 20
10 x 16 | 1 to 2 |
| 9 | 30 | 10 x 22
11 x 20 | 2 to 3 |
| 13 | 45 | 10 x 29
11 x 25
12 x 22 | 3 to 4 |
| 21 | 74 | 13 x 20
11 x 37
12 x 32
13 x 29 | 5 to 6 |
| 25 | 90 | 15 x 24
16 x 22
12 x 38
13 x 33 | 6 to 7 |
| 30 | 108 | 14 x 30
15 x 27
16 x 25
13 x 38
14 x 34 | 8 to 9 |
| 35 | 126 | 15 x 30
16 x 28
17 x 26
15 x 35
16 x 31 | 9 to 10 |
| 40 | 144 | 17 x 29
16 x 35
17 x 31
18 x 29 | 10 to 11 |
| 45 | 162 | 18 x 32
19 x 29
17 x 38 | 11 to 12 |
| 50 | 180 | 18 x 34 | 12 to 13 |

CORN JUDGING.

There is an excellent chapter on corn-judging in an exhaustive work on corn, published by the Orange Judd Company, Chicago, U.S.A. The following is a short summary of it, which should prove useful to judges at shows in Queensland:—

The great object which the judge has in mind is to select that sample of corn for first place, which, in his estimation, is best for seed purposes—namely,

Plate XXXIII.

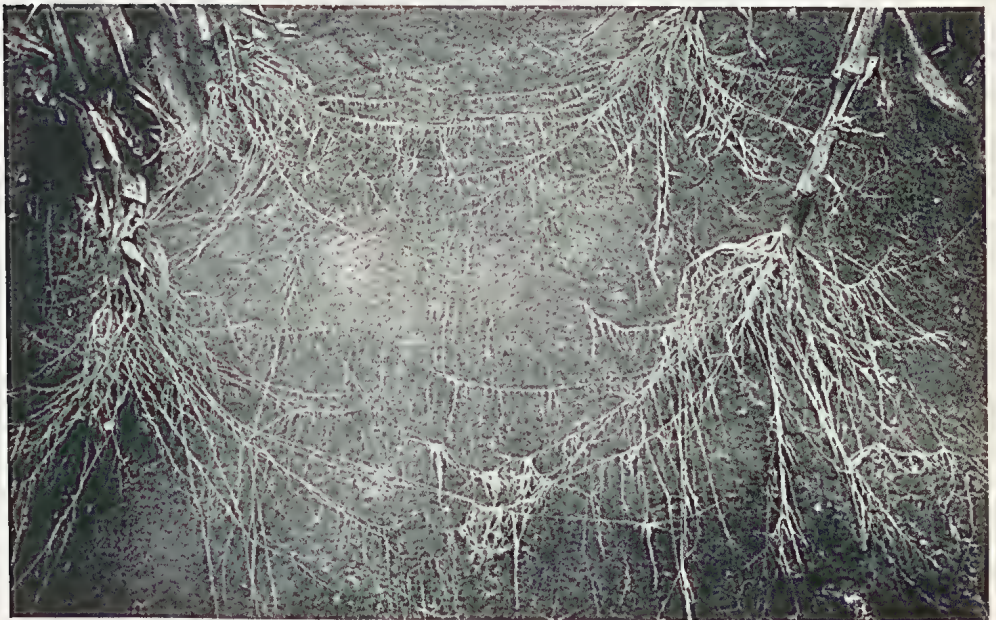

1. PROPER AND IMPROPER SHAPES OF KERNELS.

At left, kernel proper wedge shape ; second, kernel square ; third, kernel too nearly round.

2. ROOT DEVELOPMENT OF CORN IN THE FIELD.

Soil washed off only to the depth the corn was cultivated.

which will, if planted in the ensuing spring, give the greatest profit per acre in the district in which it is grown.

THE SCORE CARD.—There are certain general points in all varieties of corn which must be taken into consideration by the judge and breeder, and this has led to the formulation of these points in a so-called score card, as here given:—

Score Card for Corn and Explanation of Points.

| | Points. |
|---|---------|
| 1. Trueness to type or breed characteristics | 10 |
| The ten ears of the sample should possess similar or like characteristics, and should be true to the variety which they represent. | |
| 2. Shape of ear | 10 |
| The shape of the ear should conform to variety type, tapering slightly from butt to tip, but approaching the cylindrical. | |
| 3. Colour—(a) Grain | 5 |
| " (b) Cob | 5 |
| The colour of the grains should be true to variety and free from mixture, with the exception of a few varieties. White corn should have white cobs, yellow corn red cobs. | |
| 4. Market condition (vitality, maturity, &c.) | 10 |
| The ears should be sound, firm, well-matured, and free from mould, rot, or insect injuries. | |
| 5. Tips | 5 |
| The tips of the ears should not be too tapering, and should be well filled with regular, uniform kernels. | |
| 6. Butts | 5 |
| The rows of kernels should extend in regular order over the butt, leaving a deep depression when the shank is removed. Open and swelled butts are objectionable. | |
| 7. Kernels—(a) Uniformity of | 10 |
| " (b) Shape of | 5 |
| The kernels should be uniform in size, shape, and colour, and true to the variety type. The kernels should be so shaped that their edges touch from tip to crown. The germ or chit and the tip portions of the kernels are the richest in protein and oil, and hence of the highest feeding value. For this reason, the germ should be large, and the tip portion should be full and plump. | |
| 8. Length of ear | 10 |
| Northern sections, 8½ in. to 9½ in.; central sections, 8¾ in. to 9¾ in.; southern sections, 9 in. to 10 in. | |
| 9. Circumference of ear | 5 |
| Northern sections, 6½ in. to 7 in.; central sections, 6¾ in. to 7¼ in.; southern sections, 7 in. to 7½ in. | |
| 10. Space—(a) Furrow between rows | 5 |
| " (b) Space between kernels at cob | 5 |
| The furrows between the rows of kernels should be small. Space between the kernels near the cob is very objectionable. | |
| 11. Proportion of corn to cob | 10 |
| The proportion of corn to cob is determined by weight. Depth of kernel, size of the cob, and maturity affect the proportion. | |
| Total | 100 |

RULES TO BE USED IN JUDGING.

1. *Length of Ear.*—The deficiency and excess in length of all ears not conforming to the standard shall be added together, and for every 2 in. thus obtained a cut of 1 point shall be made.

2. *Circumference of Ear.*—The deficiency and excess in circumference of all ears not conforming to the standard shall be added together, and for every

2 in. thus obtained a cut of 1 point shall be made. Measure the circumference at one-third from the butt to the tip of the ear.

3. *Proportion of Corn to the Cob.*—The percentage of corn should be from 86 to 87. In determining the proportion of corn to cob, weigh and shell every alternate ear in the exhibit. Weigh the cobs, and subtract from the weight of the ears, giving the weight of the corn. Divide the weight of the corn by the total weight of ears, which will give the percentage of corn. For each percentage short of standard, a cut of $1\frac{1}{2}$ points shall be made.

4. In judging corn, a red cob in white corn, or a white cob in yellow corn, shall be cut at least 2 points. For one or two mixed kernels a cut of $\frac{1}{2}$ point shall be made. Kernels missing from the ear shall be counted mixed. Difference in shade or colour, as light or dark red, white or cream colour, must be scored according to variety characteristics.

5. *Exposed Tips.*—Where the full diameter of the corn is exposed, a cut of 1 point shall be made, and a proportionate cut as the cob is less exposed. Regularity of the rows near the tip, and the size and shape of the kernels, must also be considered in scoring tips.

6. *Scoring Butts.*—If the kernels are uniform in size, and extend over the butt in regular order, give full marking. Small and compressed or enlarged or open butts are objectionable, as are also those with flat, smooth, short kernels, and must be cut according to the judgment of the scorer.

7. Each exhibit should consist of ten ears of corn.

Kernel Shape.—The shape of kernel varies with different varieties, but in general there are certain conditions of shape that all kernels must fill. Such kernels fit around the cob tightly, and do not leave a space at the tip, nor a deep furrow between the rows of kernels. A broad, square kernel is usually shallow, and only a few rows of kernels grow on each cob. This means a small percentage of corn to cob. On the other hand, a well-shaped kernel is usually found on an ear with a large number of rows, and results in a large percentage of corn to cob. The sides of the kernels should be straight.

ANALYSIS OF *PHALARIS COMMUTATA*.

The *Phalaris commutata*, or Canary Grass, which has been received with great favour in this State, appears to be equally acceptable to the farmers in Cape Colony. A sample was obtained from a farmer at Waverley, which had grown to a height of 4 ft., and was unaffected by frosts. Part of this was analysed with the object of ascertaining whether the grass was worth cultivating as a fodder plant, in view of the fact that the seeds imported from Australia cost the high price of one penny each.

The composition was found to be as shown in the first line of the following table, the results of analyses of other grasses being given for the sake of comparison, and which are taken from Dietrich and Koenig's "Futtermittel," vol. 1, 1891 edition. In all cases the plants were in the air-dried or "hay" condition:—

| | Moisture. | Proteins, N.X. 6.25. | Fat. | Ash. | Total Carbo-hydrates
(including Fibre). | Fibre. | FUEL VALUE
CALORICS
PER LB. | | Nutriment Ratio. |
|---------------------------------|-----------|----------------------|------|-------|--|--------|-----------------------------------|---------------------|------------------|
| | | | | | | | Including
Fibre. | Excluding
Fibre. | |
| <i>Phalaris commutata</i> ... | 13.77 | 10.37 | 2.94 | 14.60 | 58.32 | 23.96 | 1369 | 973 | 4.0 |
| Italian Grass ... | 14.30 | 9.54 | 2.91 | 8.62 | 64.63 | 19.48 | 1427 | 1073 | 5.4 |
| Perennial Rye Grass ... | 14.30 | 10.29 | 2.70 | 8.55 | 63.91 | 28.68 | 1461 | 939 | 4.0 |
| <i>Phalaris canariensis</i> ... | 14.15 | 17.50 | 2.05 | 7.47 | 58.83 | 40.13 | 1472 | 742 | 1.3 |
| Timothy Grass ... | 14.30 | 6.31 | 1.93 | 4.29 | 73.17 | 28.25 | 1525 | 1010 | 7.8 |
| Kentucky Blue Grass ... | 14.30 | 9.75 | 2.29 | 5.52 | 68.14 | 33.88 | 1510 | 993 | 4.1 |

METHOD OF ESTIMATING THE YIELD OF COTTON IN THE FIELD.

To estimate the yield of cotton from the plants in the field, the following directions, says Mr. J. C. Crawford, Special Agent, U.S. Bureau of Entomology, will be found useful:—

Determine the average number of sound bolls per plant by counting the number of such bolls on some five adjacent plants in at least three separate places in the field, and dividing the total number of bolls counted in this manner by the total number of plants examined. Where the field is very large or contains different soils, more than three places should be selected for counting. In the first column of the following table find the distance between the plants in the field, the crop of which is to be estimated. Then refer to the number on the same line in the following column, headed by the size of bolls to which the variety planted belongs. Dividing the average number of bolls per plant in the field by the number found in this manner in the table will give the fraction of a bale per acre that will be produced.

Example.—If, in the case of a small-boll variety like the King, the average number of bolls per plant is found to be 10, and the plants are put in at a distance of 2 ft. in rows 4 ft. apart, the amount of the prospective yield per acre will be 10 divided by 25·4, or 0·39 of a bale. In using this table, due allowance must be made for a poor stand:—

NUMBER OF COTTON BOLLS PER PLANT OF VARIOUS CLASSES REQUIRED AT CERTAIN DISTANCES TO PRODUCE A BALE PER ACRE WHEN COTTON GIVES 33½ PER CENT. OF LINT.

| Distance between Plants in feet. | Number of Plants per acre. | Large Bolls, 50 to 65 per lb. | Medium-sized Bolls, 70 to 80 per lb. | Small Bolls, 85 to 100 per lb. |
|----------------------------------|----------------------------|-------------------------------|--------------------------------------|--------------------------------|
| 1 × 3 | 14,520 | 5·9 | 7·7 | 9·5 |
| 1 × 4 | 10,890 | 7·9 | 10·3 | 12·7 |
| 1 × 5 | 8,712 | 9·8 | 12·9 | 15·9 |
| 1 × 6 | 7,260 | 11·8 | 15·4 | 19·1 |
| 1½ × 3 | 9,680 | 8·9 | 11·6 | 14·0 |
| 1½ × 4 | 7,260 | 11·8 | 15·4 | 19·1 |
| 1½ × 5 | 5,808 | 14·8 | 19·3 | 23·8 |
| 1½ × 6 | 4,840 | 17·8 | 23·2 | 28·6 |
| 2 × 2 | 10,890 | 7·9 | 10·3 | 12·7 |
| 2 × 3 | 7,260 | 11·8 | 15·4 | 19·1 |
| 2 × 4 | 5,445 | 15·8 | 20·6 | 25·4 |
| 2 × 5 | 4,356 | 19·7 | 25·8 | 31·8 |
| 2 × 6 | 3,630 | 23·2 | 30·9 | 38·4 |
| 3 × 3 | 4,840 | 17·8 | 23·2 | 28·6 |

RULES FOR JUDGING WHEAT.

Exhibits of wheat should form a prominent feature at every agricultural show; but, as a rule, they do not. Every prominent grower in a cereal-producing district within a reasonable radius of where the show is being held, should compete in the section, so as to foster a deeper interest in the improvement of this important product. While hand-picked samples of grain, within certain limitations, may be accepted without objection, it would be more satisfactory to give prizes to growers who are able to produce five or six bags of grain similar in every respect to those which gained the awards. A very important matter in regard to judging wheat at shows is the recording of the weight per bushel of each of the competitive entries. Some judges decide on the basis that the heaviest bushel of wheat should win the prize. This reasoning is hardly sound, for other qualifications should also be considered, though undoubtedly weight is an important point. But if weight alone counted, then Algerian wheat, which, when well grown, is plump, bright coloured, comparatively hard, and weighs wonderfully well, would rank high, whereas it is of little use for milling purposes, and is really more suited for

pigs and poultry than flour-making. A more modest-looking grain, weighing less per bushel, may be eminently suitable for making the best flour, but the deficiency in weight, if undue importance were attached to that point, might, and probably would, result in it being neglected in favour of a more showy and bulky variety.

With regard to rules governing wheat competitions, Mr. Hugh Pye, Principal of the Dookie Agricultural College, expresses the opinion that at a suitable time previous to the show season samples of all wheats intended for competition should be placed in the hands of the Chemist for Agriculture, so that his staff may be in a position to supply all necessary information in regard to milling qualities, nature, and percentage of gluten, also other qualities which can best be determined by scientific test. Only about 2 lb. or 3 lb. of wheat would be required for this purpose, and only a few bushels need be sent to the show. But a guarantee should be given by the exhibitor that he had available several bags of exactly similar wheat. The judges at the show would then determine the weight per bushel of the grain, brightness of sample, whether clean, well-grown, &c., and, with the information obtained from the Chemist for Agriculture, award the prizes. Mr. Pye also points out that proper provision for measuring a bushel of wheat is seldom made. Generally, one of the judges has to struggle with the bag, and from it let the wheat pour into the bushel measure. But unless great care be taken to manipulate each bag in exactly the same way—and that is well-nigh impossible—there may be a difference of 1 lb. in the weight of a measured bushel. The proper way is to place the wheat in a hopper with sloping sides and having a shoot beneath, from which the wheat could pour at an even flow. The flow of grain should be cut off immediately it had run the appointed time, and then a clean strike could be made, and the grain weighed.—“Australasian.”

AGRICULTURAL CREDIT BANKS:

The Board of Agriculture and Fisheries, England, has issued a leaflet explaining the formation and operation of agricultural banks which, the leaflet points out, are co-operative societies through which farmers in a small way of business may obtain advances of money for useful purposes at a reasonable rate of interest. The following information concerning such banks is interesting by way of comparison with the working of our Queensland Agricultural Bank, which also was established for the purpose of assisting new settlers to make necessary improvements on their selections:—

Some people may be inclined to question the wisdom of supporting or encouraging any system which makes it easy for a man to conduct his business with borrowed money. This idea, however, is based upon a misconception. The wisdom of borrowing depends mainly upon the purpose for which the money is borrowed, and the possibility of borrowing upon reasonable terms is generally a question of the security which the borrower can offer.

Credit is at the foundation of modern business methods. Most public companies work with borrowed money, and so long as the company can show good security for its liabilities nobody questions the soundness of the principle.

A business man of any standing in the commercial world experiences little difficulty in obtaining temporary advances of money to meet special requirements. But the small man in an agricultural community does not, as a rule, possess the same facilities.

In the days when private banks were scattered up and down the country the position was somewhat different. A trustworthy man could then more easily obtain a credit accommodation merely on the security of his character and position. But with the gradual absorption of private firms into large joint-stock banks conditions have changed. The small farmer, the labourer

with his allotment, the market gardener, and the village tradesman, may not be in a position to borrow money through the ordinary channels of credit, because ability, experience, and honesty of character do not necessarily constitute a sufficiently acceptable security for an advance. It is such persons that a credit bank is intended to benefit.

A credit bank, however, is not a philanthropic institution, but a society based and conducted strictly upon business principles. The distinctive features of a credit bank are—

- (i.) It is co-operative—its key-note being “self-help.”
- (ii.) It is local—its members living within a small area and being well known to one another.

These two features will become clearer when we proceed to consider its

Constitution and Operations.

The village or parish is the most convenient unit of area for a credit bank. The intending members form themselves into a society which adopts rules and is duly registered by the Registrar of Friendly Societies.

The credit bank appoints its officers and committee of management, and, as soon as it is properly constituted and registered, is in a position to borrow money on the joint security of its members. This money it lends out to those of its members who are at the moment in need of ready money.

Credit banks do not distribute dividends, and, the expenses of management being very small, money can be lent at a low rate of interest, and this is the main object for which the bank is formed.

The wisdom of borrowing, it has been stated, depends upon the purpose for which the money is borrowed. The credit bank will only lend money for purposes of production or economy. This, however, allows it a wide field of action. To give but a few examples of the useful objects for which money might be advanced there may be mentioned the purchase of implements, seeds, manure, poultry, &c., or the erection of a fowlhouse, greenhouse, or pigsty. A member who wishes to borrow money must state the purpose for which he requires it, and must undertake to apply it to that particular purpose. It will then be within the discretion of the committee to decide whether the loan shall be granted or not.

A credit bank can only lend to its own members, and its success will depend upon its admitting as members only those whose industry, honesty, and integrity are beyond question. A man who possesses these qualities should have no difficulty in becoming a member of a credit bank, or in obtaining from it an advance of money for any useful and productive purpose. The bank will, however, require him to furnish sureties for its repayment.

There can be no more thoroughly democratic institution than a credit bank. It elects its officers and committee to manage its affairs, but the action of these officers will be subject to vigilant checking, and it will be to the interest of every member to see that the character of the membership is strictly maintained, and that the affairs of the bank are conducted in an efficient and business-like manner.

This interest in good management will be the more vital because a credit bank of this type must necessarily be conducted upon the principle of the

Unlimited Liability

of its members for the money raised by the society.

Lest this should cause any misgivings as to any risk incurred by the individual members, it should be pointed out that the risk may be most effectually guarded against. The possibility of loss is in any case very remote, owing to the effective control which the members can exercise over all transactions of the bank, and it is reduced to practically nothing by adopting a rule limiting the amount of money that can be lent either in all or to any one member each year. Section 46 of the Friendly Societies Act provides that a

society shall not make any loan to a member on personal security beyond the amount fixed by the rules, or make any loan which together with any money owing by a member to a society exceeds £50.

On the other hand, it is just the security of such unlimited liability which enables the society to borrow money without trouble on advantageous terms.

How very remote the risk of loss really is may be judged from the fact that in Gemany, where there are between 4,000 and 5,000 societies of the Raiffeisen Union proper, in addition to a much larger number similarly organised, it is said that no depositor or other creditor has lost a farthing since the movement was started in 1849.

In Ireland an almost equal immunity from loss is claimed by the Irish Agricultural Organisation Society, which has about 300 affiliated credit banks; and the few existing credit societies in England can tell the same story.

Deposits.

To every credit bank there should be attached a department for receiving on deposit the savings of its members. The money thus received would to some extent supplement that borrowed by the society, and would assist it in its lending operations.

Central Bank.

As credit banks are started in various localities they will strengthen their position and increase their resources by uniting to a central bank. Such central bank could then receive on deposit any surplus funds from the local banks, and assist them if necessary by making advances. It would, in fact, stand in somewhat the same relation to the local credit banks as these would to their individual members. The principle of unlimited liability, however, which is essential in the case of the separate banks, would be generally unsuitable as regards their relation to the central bank. In connection with the village co-operative credit societies affiliated to the Agricultural Organisation Society, a Central Co-operative Agricultural Bank has already been formed.

Small Holdings and Allotments.

The useful part which credit banks may play in the successful cultivation of small holdings and allotments has been recognised by Parliament, which has included in the Small Holdings and Allotments Act of 1907 certain provisions relating to these and other co-operative institutions.

County councils are given power under the Act to promote the formation and extension of credit banks, and they may, with the consent of the Local Government Board, assist such societies by making grants or advances upon such terms and such security as the council think fit. Even if they do not themselves lend money, county councils may guarantee advances made to the credit bank from other sources. The credit of a county council being first-class security, this provision should prove quite as useful in practice as the one enabling the councils to advance money.

The recognition of the principle of credit banking in an Act of Parliament, added to the experience of Continental countries extending over half a century, during which the system has been thoroughly tested, should be a sufficient guarantee of its soundness and utility, and it may with confidence be expected that the spreading of information on the subject will be accompanied by a steady increase in the number of credit banks, which, wherever established, have been attended with such signal success.

Full information as to the proper procedure can be obtained from the Chief Registrar of Friendly Societies, 28 Abingdon street, Westminster, S.W. The secretary of the Agricultural Organisation Society, Dacre House, Dacre street, Westminster, S.W., will also supply model rules on application, and is willing to conduct the necessary proceedings as to registration.

WINTER ASPARAGUS.

The market gardeners who supply Covent Garden Market, in London, with several kinds of vegetables during the severest winters, which said vegetables, in the ordinary course of nature, are produced in the spring and summer, make a very good thing out of raising asparagus in the winter.

Growing winter asparagus is quite simple, to all appearances, though there are probably subtleties about it which, unless governed by experience, lead to disaster. The "crowns" are produced in the ordinary way, and reach maturity in three years. When they are removed to the forcing bed, they are covered with fine soil to a depth of 5 or 6 in. There they live for a month in what is practically a vapour bath. The bed rests on a brick foundation, with spaces between the bricks. Underneath is a tunnel through which run iron pipes conveying a stream of hot water. They heat the water contained in an earthenware gully, so that steam is constantly produced. The bed is covered with glass frames, which serve the double purpose of confining the heat and attracting all the available sunlight; for without sunlight asparagus would not be—asparagus. The most curious difference between the forced and the natural variety is in the method of gathering it. Seasonable asparagus is cut with a knife which is as much like a fork as a knife, and the operation is a very delicate one. An unskilful cutter, by wounding the "crown" of the plant, may do an enormous amount of damage. The sticks of forced asparagus are "pulled"; just broken off by a twist of the fingers, which are easily plunged into the fine soil with which the crowns are covered. As the asparagus matures all at once, it scarcely matters whether the crown is injured by this violent method of collecting its fruit. And the crown, once forced, is thrown on the manure heap. Four crops can be grown in the same bed during the short winter season. The average price which the asparagus fetches at Covent Garden is 6s. per bundle of 100 sticks. The price, of course, varies considerably, and is always higher when Parliament is sitting and the "season" is in full swing. So it may be imagined that the winter asparagus grower takes an interest in politics, and contemplates an autumn session and the consequent later meeting of Parliament in the New Year with some misgivings.

One of the principal market gardeners in Essex is Mr. Poupart, a descendant of one of the French *émigrés* who settled in England after the Revolution. Besides asparagus, Mr. Poupart also grows a great deal of seakale, which is easy to force. It grows in complete darkness, the plants being covered during their development with what are known as Archangel mats. Curiously enough, another variety of artificially-produced vegetable, though ordinarily flourishing in sunlight, requires no light and no great amount of heat for its winter growth. You may have noticed the delicate tints of early rhubarb—the brilliant crimson of the stem and the tender yellow of the foliage. A perfectly dark barn, with a temperature of 60 deg. or so, is all the equipment necessary. Light spoils it, and if there is a crack in the roof a tinge of pronounced green and a dirty red is the result.

A rather interesting fact in connection with this Essex farm is that all its produce is conveyed to London by road and by the power of the stalwart shire horse. The distance is 16 miles, and the round trip occupies 36 hours, allowing, of course, for the necessary wait in Covent Garden Market for unloading, and so on. The railway or the motor has not yet triumphed over the means of transit which satisfied Mr. Poupart's grandfather 100 years ago. There is one point about this slower road-travelling; there is less risk of injury to the produce.

As regards growing seakale in darkness, Mr. Charles Ross, Manager at the Westbrook State Farm, is an adept in the art, and has frequently had very fine exhibits of this and similarly produced vegetables at the various exhibitions and shows in Brisbane and elsewhere.

Dairying.

THE DAIRY HERD, QUEENSLAND AGRICULTURAL COLLEGE,
GATTON.

RECORD OF COWS FOR MONTH OF MARCH, 1909.

| Number. | Cow's Name. | Breed. | Date of Calving. | Total Milk. | Average Test, Per cent. | Commercial Butter. | Remarks. |
|---------|--------------|-------------------|------------------|-------------|-------------------------|--------------------|------------|
| | | | | Lb. | | Lb. | |
| 1 | College Lass | Ayrshire ... | 31 Jan., 1909 | 1,227 | 3·7 | 50·50 | |
| 2 | Glen | Grade Shorthorn | 29 Jan. " | 953 | 4·6 | 49·20 | |
| 3 | Nellie II. | Shorthorn | 25 Feb. " | 1,159 | 3·3 | 42·25 | |
| 4 | Butter | " | 20 Feb. " | 1,017 | 3·5 | 39·47 | |
| 5 | Blackbird | Grade Holstein .. | 4 Feb. " | 889 | 3·8 | 37·64 | |
| 6 | Lady Ring | Guernsey ... | 26 Jan. " | 641 | 5·2 | 37·30 | |
| 7 | Poppy | Grade Guernsey | 10 Jan. " | 669 | 3·5 | 37·30 | |
| 8 | Laura | Ayrshire ... | 16 Nov., 1908 | 839 | 3·6 | 33·56 | |
| 9 | No. 112 | Grade Shorthorn | 12 Nov. " | 706 | 4·2 | 33·22 | |
| 10 | Whitefoot | Holstein-Devon | 20 Oct. " | 871 | 3·3 | 31·75 | |
| 11 | Rosalie | Ayrshire ... | 10 Feb., 1909 | 963 | 3·0 | 31·70 | |
| 12 | Maud II. | Shorthorn | 16 Jan. " | 669 | 4·2 | 31·47 | |
| 13 | Bangle | " | 23 Feb. " | 786 | 3·6 | 31·44 | |
| 14 | Conceit | Ayrshire ... | 22 Dec., 1908 | 810 | 3·3 | 29·53 | |
| 15 | Comet | Holstein ... | 22 Nov. " | 723 | 3·7 | 29·76 | |
| 16 | Gem | Grade Shorthorn | 2 Nov. " | 621 | 4·2 | 29·24 | |
| 17 | Careless | Jersey ... | 7 Dec. " | 674 | 3·7 | 27·74 | |
| 18 | Dot | Shorthorn ... | 12 Nov. " | 749 | 3·3 | 27·29 | |
| 19 | Peewee | Grade Holstein... | 20 May " | 626 | 3·9 | 27·06 | |
| 20 | Ethel | Holstein .. | 3 Sept. " | 645 | 3·7 | 26·54 | First calf |
| 21 | Remit | " | 5 Aug. " | 623 | 3·8 | 26·37 | |
| 22 | Nancy | Grade Shorthorn | 7 May " | 524 | 4·4 | 25·87 | |
| 23 | Len | Ayrshire ... | 6 May " | 627 | 3·7 | 25·80 | |
| 24 | Daisy | Holstein ... | 24 Oct. " | 813 | 2·8 | 25·44 | |
| 25 | Cocoa | Jersey ... | 20 Nov. " | 539 | 4·2 | 25·35 | |
| 26 | Dora | Shorthorn ... | 18 Nov. " | 711 | 3·1 | 24·25 | |
| 27 | Lalla | Holstein ... | 28 July " | 525 | 4·0 | 23·46 | First calf |
| 28 | Dewdrop | " | 11 Nov. " | 742 | 2·8 | 23·22 | |
| 29 | Eve | Jersey ... | 16 Oct. " | 500 | 4·0 | 22·35 | |
| 30 | Lowla | Ayrshire ... | 8 Dec. " | 608 | 3·8 | 22·17 | |
| 31 | Lady Loch | " | 24 June " | 384 | 5·0 | 21·67 | |
| 32 | Duchess | Shorthorn ... | 3 Mar. " | 523 | 3·7 | 21·52 | First calf |
| | Fanny | | | | | | |
| 33 | Nita | " | 23 Nov. " | 517 | 3·7 | 21·27 | |
| 34 | Orange | Grade Guernsey | 23 Oct. " | 365 | 5·2 | 21·24 | |
| 35 | Burton's | Shorthorn ... | 7 Sept. " | 426 | 4·4 | 21·03 | First calf |
| | Fancy | | | | | | |

Natural pasture only.

SPECIFICATIONS FOR ERECTION OF PIGGERIES.

Site.—Select a suitable and convenient position with an aspect to protect from cold winds and excessive sun's rays.

Drainage.—Take ground levels and adjust building to insure rapid discharge of liquids from concrete floors direct into concrete drain. Where necessary, the ground should be brought to an even grade, and if in the case of a sharp slope the building is erected to follow it, a shallow drain in the concrete floor should be provided on the lower side of each individual pen, to discharge into the main drain.

Material.—Where bush timber is not available, use sawn, in suitably matched sizes; this latter timber admits of better hygienic conditions.

Galvanised iron, protected by a cooling paint, is preferable to a bark or thatched roof.

Concrete Footing.—Cut out trench and fix boards to complete a mould to form a footing for ground plates 18 in. deep by 8 in. in width, with a bevelled edge at the outside to carry off the drip from walls. Set in a few bolts at intervals to secure ground plates in position. A similar footing, with the necessary dip to give drainage, may be used between pens to carry plates; but where the timber can be checked in flush and bolted to the uprights forming the front of building, the footing may be dispensed with, and the same purpose secured when the concrete flooring is put in.

Frame.—Halve at ends and fix ground plates, morticing for uprights and studs on back wall; cut to suitable tenons for top and ground plates. Frame for sliding door, using a bevelled top sill as shown on plan. All uprights for front of building and posts forming the small pens should be based on a 6-in. layer of concrete, and set in the same material, when fixed in correct position.

Check out for front top-plate, bolt, fitting raking plates to securely tie the building.

Rafters.—Check for plates and securely spike, allowing for suitable overhang.

Iron.—Secure with not less than one and a-half corrugations by means of lead-head nails.

Use 16 in. ridge-capping, as shown at apex of roof. Attach fascias and fix 24-gauge O.G. guttering with brackets, giving the necessary fall.

Slabs.—Trim to an even thickness at ends, and secure with cleats, firmly spiked to plates.

Sliding Doors.—Fit as detailed on plan with hasp and staple to each.

Kerb.—Scarf out uprights in front of covered pens and bolt in wooden kerb for concrete. A similar protection should be made to the main drain running along front of pens. In the latter case bolt the kerb to stout supports sunk in the ground, which may be strengthened by being set in concrete.

Yard.—Uprights should be placed on a 6-in. layer of concrete, and firmly set in the same material.

Horizontal rails or battens may be secured by means of cleats and nailed, but cap rail should be cut to a stout tenon and firmly bolted to uprights at each end. Stiffeners should be put in centrally on each side of the division rails and nailed.

Troughs.—Use hardwood $1\frac{1}{4}$ in. in thickness. Fit tongues made on the side pieces into grooves cut in bottom board of each. Use solid ends, ploughed out to receive sides. Screw together with caulked joints. Bolt the whole firmly together at top and bottom to prevent spreading.

Pivots of $\frac{7}{8}$ in. round iron should be stumped on to $\frac{3}{8}$ in. flat iron plates bored for 4 holes. Countersink plates and attach to each end of trough, using $\frac{3}{8}$ in. cup-headed bolts for the purpose. Troughs may thus be tilted and flushed out easily.

Swinging Door.—The cap rail for hinging door to, is to act as a brace for uprights at each end of it, and a packing piece should be attached to the uprights to follow the same travel as the door. The door may be held in alternative positions by means of a sliding batten or barrel bolt.

Use hook-and-band type of hinge.

Floor.—The floor should be laid with concrete 6 in. in thickness, compounded as described below, with a fall of not less than 2 in. in 8 ft. The concrete at front of covered pens should have an 8 in. by 2 in. hardwood kerb securely fastened to uprights. Arrange for a drop of $2\frac{1}{2}$ in. to 3 in. out of the covered into the open pens. The concrete in the latter should slope as previously mentioned to a point immediately under trough, from which it should dip sharply into the main surface drain; this latter to be properly kerbed, as

shown, and be laid in sections of 8 ft., with a clean joint between sections. The covered-in sleeping pens should be provided with a flooring of wood, made "removable" to rest on the concrete.

The most suitable compound to form concrete will depend upon the class of material available. Apart from the usual practice, a good floor may be made as follows:—

Grouted Rubble Concrete.—Pack the floors to a depth of 6 in. with suitable stone of 4 in. or 5 in. gauge. Ram to an even surface, and gauge fall with a straight edge. Damp the stone before grouting. Take 5 parts of coarse, clean sand to 2 parts Portland cement; mix thoroughly when dry, and sieve well. Then mix with water and bring to the consistency of thick cream, and brush the grout well into all joints and interstices.

Preparation of concrete according to specifications and description compiled by Mr. Arthur Morry, for construction of cattle dips.

The strength of concrete varies considerably, according to the quantity and the quality of the cementitious material used, also according to the nature of the aggregate employed. A coarse, clean sand and broken metal with sharp edges and irregular surfaces give a material of greater strength than that produced by fine sand and rounded water-worn pebbles, because a better surface is offered for the interlocking of the crystal formation.

Concrete diminishes in bulk from 20 to 30 per cent. when the materials composing it are mixed together, well wetted, and finally well rammed in position, so that 1 cubic yard of finished concrete composed of 6 parts of aggregate to 1 part of cement requires 1 cask or 3 bags of cement and about 31 ft. cube of gravel or other material.

The quality and proportion of the sand used are important factors in producing good work; it should not be too fine in grain or the particles to be united together become too numerous for the quantity of cementitious material employed; it should be free from muddy or clayey particles, as these deleteriously affect the formation of crystalline silicates of lime and alumina, without which the proper setting or hardening of Portland cement concrete cannot take place. The sand should also be in just sufficient quantity to fill up the interstices of the metal or gravel, and produce a compact mass when the whole is bound together.

A broken metal or other aggregate which is slightly porous produces a stronger concrete than river pebbles which are almost impervious; for this reason of old broken bricks, if hard, are excellent material to use.

A simple plan for testing the proper quantity of sand to be used is the following:—

Provide a box containing, say, 1 cubic foot (or a kerosene tin will answer the purpose), and fill it with broken metal or gravel; after sifting out all the sand through a fine sieve, fill it with water, and allow to stand until the stones have become thoroughly saturated and will absorb no more, pour off the remaining water, then take another similar vessel, fill it with water, and pour into the first until the spaces between the stones are filled and the water runs over the top; now measure the quantity which has been used out of the second vessel, add to it 20 per cent., and this will give the quantity of sand necessary to produce a first-class concrete.

If pit sand is used, it should be washed to get rid of the clayey matter; it can be tested by stirring in a glass with water, when the clay will be deposited on top when settlement takes place.

Cement.—Only the best Portland cements should be used for cattle dips; usually any of the cements offered in the Queensland markets is suitable for the purpose, but occasionally a damaged shipment is offered at a low price, from which good results cannot be obtained. Work executed with materials of

1871

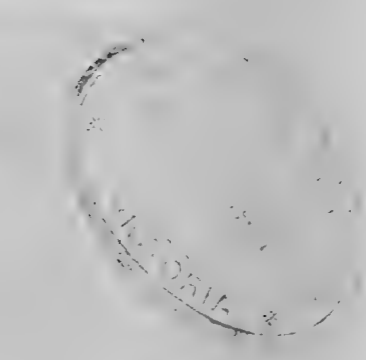

1871

this class in cattle dips is invariably a complete failure. Some cements set much more slowly than others; these should not be rejected on that account, as their ultimate hardness will often exceed that which sets more quickly.

Water used for making concrete should be clean and fresh, and, if possible, free from organic matter and lime in solution. From 21 to 24 gallons is required for every cubic yard of dry materials.

Provide a gauge-box of 1-in. pine, 3 ft. by 3 ft. by 1 ft. 2 in., strongly nailed and clamped together; this will gauge about 1 cubic yard of finished concrete when filled three times.

The concrete should be composed of 1 cask or 3 bags of best Portland cement to 3 gauge-boxes, or 31 ft. 6 in. cube of aggregate, which should consist of clean river gravel passed through a 1½-in. mesh sieve, and the surplus sand removed as previously described; or of 1½-in. broken metal and a sufficient quantity of clean coarse sand to fill in the interstices. It should be turned over twice dry and twice wet, thoroughly well mixed, then wheeled or thrown into position, packed with a shovel to the proper level, and thoroughly well rammed until the water appears on the surface. Care must be taken not to use too much water or the strength will be reduced, but sufficient should be used to work up the cement to the surface on well ramming.

It is most important that the mixing is thorough, because it is in imperfectly mixed concrete that cracks and flaws appear. The best way is to mix the sand and cement together thoroughly in a dry state, then place the stones on the top, mix well together dry, then add the water through the rose of a watering-can and proceed as usual.

THE SPIDER PEA.

Mr. D. O'Connor, Oxley, writing on the subject of the Spider Pea, gives a very interesting account of its introduction in the early sixties into Victoria from India by a Victorian squatter. He was fortunate enough to obtain a few of the seeds, and found they produced an excellent crop of delicious peas. On settling in Brisbane, in 1876, Mr. O'Connor found that this pea was unknown in Queensland and in the Southern States amongst the seedsmen.

At last the "Australasian" published a letter from Mr. O'Connor, stating his want of success in obtaining the seed. That journal said:—"He (Mr. O'Connor) describes it as the most delicious pea he ever tasted, easily cultivated, requiring no sticks; stood dry weather well, and retained its tenderness longer than any other kind. It was called the 'Spider' because of its habit of growth, stooling out in all directions, therefore rendering it necessary to sow the seeds 36 by 18 in. apart."

The editor added:—"Forty years ago the spider pea could be bought in Melbourne at 2s. 6d. per lb., but from some unexplainable cause it is not to be seen in any Victorian seedsman's catalogue of the present day."

After the publication of Mr. O'Connor's letter in the "Australasian," he received several letters from gentlemen who had once grown the pea in question; but they were no longer in possession of any.

Finally, a letter was received, accompanied by a few seeds of the long-sought pea. "These," says Mr. O'Connor, "though late in the season, were at once sown; I was delighted when I saw the stems spreading out in all directions; I counted seventeen from one root. This was unusual, the average is about ten or twelve."

Seeds are not available at present, but I hope will be next season, when they will be distributed by a Brisbane seedsman, of which due notice will be given.

The Horse.

CARE OF HORSES.

Good farm horses cost money, and no one can afford to injure any expensive chattel. Horses are the farmer's willing slaves, and if they are treated kindly, fed well and judiciously, not over-worked, their strength not unduly taxed, there is nothing in reason they will not willingly do. Why beat and starve a horse? Why work him until he is ready to drop with heat and thirst? Why leave him standing alongside the plough in the blazing sun, or bleak, cutting wind, whilst you or your man go to the house for dinner and an hour's comfortable rest? Of all cruelties to a horse, one of the most inhuman is to work the animal from early morning till noon without being allowed a spell or a drink unless the ploughman wants a spell himself. The horses may or may not have had a drink before going to work, yet at noon they get a feed of dry lucerne hay and a little corn; then, mad with thirst, they are taken to a creek or waterhole, and are allowed to drink all they can, with no thought of the possible bad effect of the cold water on an overheated system.

Horses require water at frequent intervals. To let an animal drink at 7 a.m., and then work it till noon without any refreshment, is cruelty. If those in charge of horses would only pause and think of the effect of a drink on themselves, perhaps they would have more consideration for the patient horses. The man feels thirsty after following the harrow in the dust for an hour, and he quenches his thirst from the water-bag. It is not long, however, before he again feels he must have a refresher. Why can he not consider that the same causes produce the same effect on his horses? There would be little time lost if they were allowed a drink every two hours, and they would work all the better for it.

It has been found that a horse drinks less water in a given time if he has continual access to it in the stable than when watered at long intervals. A horse should always be allowed to quench his thirst on coming from work, even if he is hot. A very general opinion exists that it is injurious to water horses when in such a state of heat, and they are therefore, in many instances, not watered until they have somewhat cooled down; this opinion is wrong, as it does not hurt horses to drink cold water directly they return from work. It is, however, hurtful to let a horse drink after he is partly cooled down, and this practice is very liable to cause a chill to the system. It may often be noticed that horses that have come in hot, and are not watered directly, but some time afterwards commence to shiver after drinking a bucketful of water, whereas, if a horse is allowed to drink before the blood has cooled down, he will not do so. The explanation of this, no doubt, is as follows:—Cold water, on entering the body, absorbs a certain amount of heat from the system, in order to bring its temperature up to the internal temperature of the animal drinking it. In the case of a horse in a hot state, the loss of heat is not felt, as there is sufficient heat to spare, whereas, in a horse which has already partly cooled down, and whose system has begun to flag, the sudden further loss of heat occasioned by the cold water entering the body, and absorbing heat causes the system to become chilled.

Now, as to feeding horses. The animal's constitution must be studied. One horse will have a good appetite, eat up all his dinner, and be ready for the afternoon's work in a reasonable time, whilst a horse with a poor appetite will take more time, and pick out the best parts. This is no fault of the

horse. He wants some appetising medicine. Give him something less in quantity but better in quality—a little bran or pollard, for instance. This will enable the weaker horse to keep up to his work. Old horses must have more attention than young ones in the matter of food. It is unreasonable to expect old horses to do the same amount of work as younger ones on the same kind and amount of food. Remember that horses have small stomachs, so they should not be fed too much at one time. If you allow a horse to gorge himself, he will get indigestion.

Hay should not be fed in the middle of the day. The heaviest feed should be given at night, when the animals will have plenty of time to digest it. Some horses require more hay or chaff than others. The amount of food a horse requires varies with the speed at which he is worked. Suppose a horse to walk $12\frac{1}{2}$ miles, he will do the distance comfortably on $19\frac{1}{2}$ lb. of hay, but if you trot him over the same distance, even 24 lb. of hay is insufficient. Scientific men have shown that a horse weighing 1,000 lb., and doing only moderate work, requires but $11\frac{1}{2}$ lb. of digestible food daily; but, with average work, he requires $13\frac{1}{2}$ lb.; and, when heavy work is being performed, $16\frac{1}{2}$ lb. If, in each case, the animal gets 10 lb. of hay, he would require, in addition, $11\frac{1}{2}$ lb. in an equal mixture of maize and oats in the first instance, 15 lb. in the second, and 20 lb. in the third. No draught horse should be allowed more than 12 lb. of hay or chaff in a day. Farm working horses, in good seasons, consume too much of this coarse fodder. If the hard-working horse were fed on hay alone, he would require 40 lb., but such a supply would be fatal to good results, and absurd to supply.

An excellent feed for a horse doing moderate work—a horse weighing 1,000 lb.—is a mixture of 10 lb. of hay with $11\frac{1}{2}$ lb. of oats, or with $10\frac{1}{2}$ lb. of maize and oats in equal parts, or 8 lb. of oats and 4 lb. of bran. Barley may be substituted for oats.

Finally, never leave your horses, after they return in the evening to the stable, without giving them a good rubbing down. An old saying is, that a good rub down with brush and curry-comb is as good as half a feed. Clean them from nose to tail, and dry them off with a cloth. Look to any sores they may have, and apply liniment or ointment to them. In raw, cold weather, when your horses have to stand for any time in the wet, cover their loins with a cloth. It will prevent the risk of their catching cold. Treat your horse, in fact, as you would treat yourself. Feed him well, treat him kindly, don't overwork him, give him comfortable quarters, and you will not often require the services of a veterinary surgeon. It is well for all horse-owners to study some book on veterinary science, in order, at least, to be able to recognise the more apparent ailments of the animal, and those which will yield to the very simplest treatment. In any case of difficulty or doubt, consult a surgeon as early as possible.

“THE AUSTRALIAN SUGAR JOURNAL.”

We are in receipt of the first monthly number of Vol. I. of the newly-launched “Australian Sugar Journal.” On the principle that “good wine needs no bush,” this first issue needs no criticism—beyond this, that the matter is well chosen, the subjects of deepest interest to sugar-growers and workers dependent on the industry are well and temperately discussed, whilst the illustrations are clear and instructive. The journal should prove of great value to all interested, directly or indirectly, in the, at present, greatest of Queensland's industries. The subscription, including postage, is 5s. per annum, and, as a correspondent of the “Journal” says: “No one, surely, can aver that the charge is unreasonable.”

Poultry.

TO FATTEN YOUNG FOWLS.

The quickest way to fatten fowls for the table (says "Garden and Field") is to put them into special coops and feed them with meal. Premising that they be young—say, 16 to 18, or even 20 weeks' old—and fleshy, two weeks' confinement ought to make them very good. The birds must have room in the coop to stand up and shift their positions, but not to move about. They should be fed three times regularly each day, and their food should be soft meal, as it is almost impossible to get fowls in proper form on hard corn. Pollard, barley meal, Indian meal, or rolled and ground oats, mixed with a little rice flour and skim milk, and occasionally dripping or suet, is good food. The feeding troughs, which must be kept constantly scoured, should be placed before the birds at regular intervals, the first being directly at daybreak; and when they have eaten sufficient it is best to remove the troughs, placing a little gravel within reach of the fowls to assist digestion. The food should be freshly mixed each day, and no more given than will be eaten clean at each meal.

Keeping the fowls without food for some hours after they are put up frequently induces them to take it more readily afterwards; but sufficient attention is rarely bestowed on the various details of preparing and supplying food, hence complaints of the fowls deteriorating in the fattening pen are far from uncommon. A coop 3 ft. high, 2 ft. wide, and 4 ft. long will admit from six to eight fowls; the bottom and front should be of bars 3 in. apart; a board outside, in front, 3 in. wide, will serve as a stand for the food trough. The coop should be kept dark between the times of feeding, by hanging old sacks over the front during the day. Sleep and warmth promote fattening; but stale food, irregular times, coops in draughts and places not protected from cold, and the sight of fowls at liberty, do not. The coops should be about 3½ ft. from the floor, and underneath strew ashes or dry earth, mixed with powdered lime, so that the droppings of the fowls may be easily removed. Perhaps the best class of fowls for fattening purposes is a heavy docile sort, or crosses of these breeds with each other or with an Indian game cock.

DO HENS GET TOO FAT TO LAY?

Many poultry owners hold the belief that hens, to lay properly, should not be too fat. On this point, Professor James E. Rice, a well-known poultry expert at the New York Experiment Station, says:—

"Last fall we killed a large number of hens, and found that the fattest hens were those in the best laying condition, and since that time we have been making careful observations on that point. A hen to be in good laying condition must have fat in her body. The production of eggs is based upon one of the experiments, and we found the fact that the hen has lots of stored-up energy in her condition; and a hen cannot lay an egg until she has got fat in her body, because the yolk in an egg is about half fat, and she has got to have oil there to make the best part of the egg. The fattest hens we killed were in the best laying condition, and the poorest hens we turned out by themselves, and there was not the faintest chance of their laying for two or three months."

There is no doubt but that the laying of eggs requires a great deal of "stored-up" energy in the hen, and it is naturally to be presumed that a hen in good condition would be more able to stand a drain on her system than a poor bird. The matter of fat in hens we believe is a great deal like high condition in breeding stock of any kind.

Poor breeding or poor egg production is not caused so much by high condition as by the manner in which this state was brought about, and the subsequent care given the animal. A good plump form, resulting from proper feeding of proper foods, followed by proper care, will not be conducive to bad results in the pen. A hen needs lots of nourishing food if she will continue to lay eggs; a starved hen will not fill the egg case very soon. Too much fat, however, and too little exercise, is a cause of hens not laying. But there need be little fear of a hen becoming too fat if she is healthy, and has the proper amount of exercise. Herein lies the reason for feeding grain amongst a straw litter in the winter time. Do not feed a single grain, and that one extremely rich in fat-producing elements, but feed a mixture, the more kinds the better, and feed it in a good litter so that the hens will have to hunt for it. High condition caused in this way will not be the cause of non-egg production.

Statistics.

COMMONWEALTH METEOROLOGY.

RAINFALL OF QUEENSLAND.

TABLE SHOWING THE TOTAL RAINFALL FOR EACH MONTH OF THE YEAR IN THE AGRICULTURAL DISTRICTS OF QUEENSLAND.

| STATIONS. | 1908. | | | | | | | | | | | 1909. | | |
|------------------------------|-------|--------|-------|-------|-------|------|-------|------|------|------|-------|-------|-------|--|
| | Mar. | April. | May. | June. | July. | Aug. | Sept. | Oct. | Nov. | Dec. | Jan. | Feb. | Mar. | |
| <i>North.</i> | | | | | | | | | | | | | | |
| Bowen | 9.16 | 3.73 | 0.99 | 0.45 | 0.88 | 0.51 | 0.96 | 2.47 | 0.12 | 0.12 | 15.18 | 4.52 | 1.06 | |
| Cairns | 20.60 | 5.99 | 3.05 | 0.59 | 3.70 | 2.12 | 0.74 | 3.07 | 1.60 | 1.41 | 32.05 | 5.25 | 21.03 | |
| Geraldton | 34.00 | 14.23 | 18.52 | 2.64 | 8.11 | 3.66 | 2.81 | 6.93 | 3.89 | 1.69 | 47.92 | 10.29 | 37.31 | |
| Gindie State Farm | 6.25 | 0.02 | 0.112 | ... | 0.40 | 1.27 | ... | ... | ... | ... | ... | ... | ... | |
| Herberton | 8.92 | 1.10 | 0.38 | 0.31 | 2.36 | Nil | 0.51 | 1.27 | 0.61 | 0.78 | 12.41 | 2.28 | 3.52 | |
| Hughenden | 6.91 | 0.30 | Nil | 0.05 | 0.68 | Nil | Nil | 1.67 | 1.94 | 1.05 | 7.55 | 1.55 | 2.86 | |
| Kamerunga State Nurs. | 25.75 | 1.60 | 3.363 | 0.76 | 4.85 | 1.53 | ... | 3.64 | 1.69 | ... | ... | 3.62 | ... | |
| Mackay | 17.43 | 14.82 | 3.25 | 1.29 | 1.65 | 0.71 | 2.27 | 1.80 | 2.57 | 0.02 | 15.00 | 1.36 | 9.00 | |
| Rockhampton | 9.77 | 2.62 | 0.85 | 0.10 | 1.08 | 0.84 | 0.20 | 2.14 | 2.47 | 1.37 | 0.01 | 2.01 | 1.68 | |
| Townsville | 9.03 | 0.38 | 2.22 | Nil | 1.70 | 0.27 | 0.28 | 1.58 | 1.26 | 0.07 | 6.91 | 1.70 | 7.01 | |
| <i>South.</i> | | | | | | | | | | | | | | |
| Biggenden State Farm | 9.84 | 2.97 | 0.74 | 0.43 | 0.49 | 2.33 | 1.39 | 1.80 | 2.12 | 3.66 | 7.37 | 2.68 | 2.45 | |
| Brisbane | 18.19 | 2.45 | 2.40 | 0.17 | 0.77 | 2.83 | 0.67 | 1.77 | 2.25 | 1.24 | 1.99 | 2.72 | 2.65 | |
| Bundaberg | 7.35 | 1.13 | 0.67 | 0.39 | 0.75 | 1.56 | 1.10 | 2.39 | 0.73 | 3.34 | 6.52 | 3.70 | 5.06 | |
| Dalby | 7.61 | 0.11 | 0.37 | 0.63 | 0.14 | 1.81 | 1.13 | 2.55 | 3.65 | 1.56 | 1.46 | 3.55 | 0.99 | |
| Dalby | 17.04 | 2.83 | 1.07 | 0.23 | 0.46 | 2.75 | 2.16 | 1.29 | 5.99 | 3.62 | 2.64 | 3.21 | 3.27 | |
| Esk | 10.74 | ... | 0.10 | 0.16 | 0.6 | 2.71 | 1.84 | 1.93 | 5.71 | 1.29 | 1.91 | 5.00 | 3.18 | |
| Gatton Agric. College | 8.08 | 1.87 | 2.00 | 0.38 | 1.16 | 2.87 | 1.37 | 2.19 | 2.58 | 3.97 | 3.86 | 3.77 | 3.41 | |
| Gympie | 13.77 | 2.71 | 1.11 | 0.12 | 0.47 | 3.23 | 1.19 | 1.18 | 5.09 | 1.05 | 1.37 | 1.95 | 2.66 | |
| Ipswich | 11.40 | 2.52 | 1.05 | 0.46 | 0.81 | 1.98 | 1.05 | 1.84 | 1.92 | 1.61 | 8.36 | 7.11 | 2.28 | |
| Maryborough | 2.51 | 0.22 | Nil | 0.55 | 0.63 | 1.38 | 1.12 | 2.15 | 2.79 | 1.68 | 5.19 | 4.85 | 4.18 | |
| Roma | ... | ... | ... | ... | 1.27 | 0.73 | ... | ... | ... | ... | ... | ... | ... | |
| Roma State Farm | 14.39 | 7.59 | 8.66 | 0.75 | 1.97 | 2.70 | 2.18 | 2.31 | 7.50 | 4.12 | 6.44 | 3.31 | 1.31 | |
| Tewantin | 6.65 | 1.40 | 0.15 | 0.80 | 1.24 | 2.99 | 1.96 | 0.96 | 5.23 | 2.02 | 0.87 | 0.82 | 1.30 | |
| Warwick | 1.41 | 1.10 | 0.05 | ... | 0.49 | 1.97 | ... | ... | 2.05 | ... | ... | 2.61 | 1.43 | |
| Westbrook State Farm | 16.62 | 5.45 | 4.59 | 0.58 | 2.64 | 2.18 | 1.50 | 3.10 | 6.03 | 2.75 | 6.69 | 6.42 | 3.71 | |
| Yandina | ... | ... | ... | ... | ... | ... | ... | ... | ... | ... | ... | ... | ... | |

NOTE.—The rainfall data in this table are compiled from telegraphic reports, and must be considered as approximate only.

GEORGE G. BOND,
Divisional Officer.

The Orchard.

HOW TO PULP FRUIT.

The principle under which fruit is preserved in the form of what is termed "pulp" is the same as that of canning or bottling. The process, however, varies slightly to meet the requirements of a separate branch of trade.

Canned fruit is preserved in such a form as to be available for use for every table.

Fruit-pulp supplies a demand among jam manufacturers and confectioners for fruits, large and small, in a more concentrated form than the canned article at seasons of the year when they are not to be procured fresh. The demand for fruit-pulp in the Home markets has hitherto been met mainly from the south of Europe. To compete successfully in an established market it will be essentially necessary to adopt the size of tin, and style of package, which has already found favour with the buyers.

SIZE OF TINS AND STUDS FOR LARGE FRUITS.

Round tins are used, 10 in. deep, $5\frac{3}{4}$ in. to 6 in. in diameter, to hold 10 lb. of fruit when filled. Studs of tins should be 3 in. to $3\frac{1}{2}$ in. wide. A large stud is needful to avoid as much as possible crushing the fruit in filling the tins. The package will contain ten tins to the case.

PROCESS FOR LARGE FRUITS.

Large stone fruits, such as apricots, are halved, and the stones removed. Apples and pears will be halved or quartered, peeled, and cored (these for home or colonial requirements). The tins are filled with fruit, tightly packed, to which little or no water is added (in this the process differs from that of canning), placed in a shallow boiler, the water in the boiler brought up to and kept at boiling point until the whole of the contents of the tins has reached that degree of heat. It will then be found that the fruit has settled considerably, necessitating the refilling of each tin with the cooked fruit. The tins having been refilled, the studs are soldered on with the vent holes open, again placed in the boiler, and the contents a second time brought up to boiling point. The vent holes are then stopped, and the tins cooled as quickly as possible. The cooling will be hastened by leaving spaces between the rows of tins and placing battens between the different layers.

SIZE OF TINS AND STUDS FOR SMALL FRUITS.

Tins of 4-gallon capacity, similar to those used for kerosene, but of heavier material, are used, with studs 2 in. in diameter.

PROCESS FOR SMALL FRUITS.

Small fruits, such as raspberries, are preserved in quantity, the fruit in this case being cooked for one hour in the steam-jacket pans used in jam factories, or, where the preserving is done at or near the orchard, in an ordinary copper boiler; constant stirring being necessary to prevent scorching, which would affect the flavour and marketable value of the finished article. The cooked fruit should be rapidly ladled from the boiler into the tins, a large-sized funnel being used to expedite the work, in order that there may be no unnecessary delay, with consequent loss of heat, before the stud is soldered on and the vent hole closed.

THEORY OF THE PROCESS.

The necessity for exercising care in each step of the process will, perhaps, be better understood when the theory is fully comprehended. All fruits having attained a certain degree of ripeness ferment more or less readily. In the preparation of fruit pulp, as in canning, a sufficient degree of heat is employed to destroy all germs of fermentation. While that degree of heat (in no instance should it be allowed to fall below 180 deg. Fahr.) is still maintained the tins are soldered, so that the atmospheric air is entirely excluded, and with the air the germs of fermentation. It will be evident that there must be no time lost before hermetically sealing the tins when once the fruit has been removed from the fire-heat.

NECESSITY FOR CAREFUL TESTING OF TINS.

It is essential that each tin should be carefully tested before being finally packed. For this reason, it is advisable to defer packing for shipment for ten days or a fortnight after preparation. During this period, if the conditions are favourable, as is usually the case during the fruit season, fermentation in the defective tins will have commenced. Tins that have been hermetically sealed, on cooling, show contraction. The reason of this is that the contents expand under the heat employed, and again contract on cooling, leaving a vacuum which the atmospheric air endeavours to fill, compressing the tins in its efforts to do so. Those that have a hole, however small, will keep their usual shape, the air entering as the contents of the tins contract in cooling. When fermentation has commenced this will frequently bulge out, owing to the expansion of the contents, caused by the gas formed in fermentation. To make quite sure tins may be plunged upside down in boiling water, when the expansion under heat will cause bubbles to rise from each defective tin, and the weak spot on each can be marked and resoldered. Fruit in defective tins will require to be treated a second time, as at first, but if fermentation has commenced the flavour will have so deteriorated that it should not be graded first class, the current market value being lessened in proportion to the loss of quality, probably one-half.—“Farm.”

TRAPPING MOTHS.

The Journal of the Jamaica Agricultural Society takes the following from “Chambers’s Journal” for December:—

In order to mitigate the pest of caterpillars which is wreaking such havoc in defoliating the forests of Germany, a novel expedient has been adopted. The irresistible fascination of the candle-flame to the moth is well known, and entomologists are aware that street electric arc lamps afford a happy hunting ground. The German authorities have turned this point to advantage. An electric light is erected on a suitable tower, beneath which is a deep, funnel-like vessel carrying powerful exhaust fans. These electric lights are fitted with powerful reflectors, which project the light in two well-defined rays upon the dark background of the forest, half a mile away, in much the same way as the beams of a searchlight. The result is described as remarkable. The hordes of brown moths that lay the eggs producing the caterpillars in such enormous quantities, dazzled by the light, come fluttering hastily towards its source. As they near the lamp they become caught in the vortex set up by the revolving fans, are sucked up, and swept through the funnel into a suitable receiver, subsequently being destroyed in the furnaces. So eminently successful was the first night’s experiment, when some 3 tons of moths were caught, that another similar installation is being erected. Though the defoliation of the trees may not be completely arrested, this wholesale destruction of the plague will certainly result in a heavy diminution in the ranks of the caterpillars, and the timber will be saved.

Horticulture

FLOWER GARDENING, No. 16.

PLANTS SUITABLE FOR IN AND OUT DOOR CULTURE.

By THE EDITOR.

ORNAMENTAL GRASSES.

"A garden, from the beginning of time, and with all peoples, has been a refreshment to the spirit, and a repose to the flesh: a delight in the spring of life and of the year; a refuge in the autumn from the winds that sweep over us; a spot full of hope and peace, where nothing dies that may not be born again."—C. Hamilton Aide.

Although the increase of refinement in horticultural taste has brought into some prominence this ornamental class of plants, very few of the order Gramineæ are suited for the garden, especially if the latter be small. Most that are worth cultivating are best kept in pots, as when grown in the border they generally present a wild, weedy appearance. Some, however, are really beautiful and graceful, and are eminently suited for the garden.

THE BEST VARIETIES

are:—*Gynerium argenteum*, well known and universally grown in Queensland under the name of "Pampas Grass." It is the grandest of all ornamental grasses, bearing panicles like large, silver-white feathers, on stems rising to a height of from 6 ft. to as much as 12 ft., presenting an appearance of picturesque beauty, scarcely equalled by any of our hardy plants. It has few rivals for beautifying an open space, such as a wide lawn or terrace. The plant is perfectly hardy in this country, and increases in size with freedom; it may be readily propagated by division of the large thick tussocks. The species has been known under several names, succeeding botanists having conferred fresh titles, which in turn have been superseded. Thus it has been known as *Arundo diæca*, *A. Selloana*, *Gynerium argenteum*, *G. dioicum*, *G. purpureum*, and *Cortaderia argentea*.

STIPA PENNATA (Feather Grass).

This is a very beautiful grass, its group of stems bearing resemblance, after blossoming, to a delicate tuft of whitish feathers, like the tail of a bird of paradise. It presents a most attractive appearance in borders, and, when cut, forms a pretty permanent in-door ornament.

AGROSTIS NEBULOSA (Cloud Grass).

One of the lightest and most graceful of all grasses. Its panicles, when developed in a mass, resemble a cloud resting over the ground. It is suitable for bouquets and for mixing with flowers in vases. *Agrostis pulchella* is a dwarfer species than the preceding, and more rigid; consequently of more value in bouquet making and drying for winter bouquets.

ERAGROSTIS ELEGANS (Love Grass).

A strong-growing, hardy annual, with broad foliage, which, with the stems, is covered with down. The panicles of inflorescence which emerge from the leaves are much branched, and are of a purplish colour. It is very useful for bouquet and vases.

BRIZA MAXIMA (Quaking Grass).

Briza gracilis and *Briza minima* (Shivery Grass) are very beautiful when bearing their heads of blossom, resembling little heart-shaped lockets suspended from delicate, thread-like stems, and moving constantly with the slightest breeze. A pot of either species, placed amongst other annuals, affords pleasing variety.

ZEA JAPONICA QUADRICOLOR GIGANTEA.

This is a grass of dwarf bushy growth. The leaves are yellow, striped with green, rose, and dark-red. The colouration and striping are very intense.

ARUNDO .

Arundo versicolor (Ribbon Grass): This pretty, striped grass, so useful in giving effect to a bouquet, is equally effective in the open border.

A. donax is another striped grass somewhat like the preceding, but with stouter stems and more than 7 ft. or 8 ft. high.

ANDROPOGON SHOENANTHUS (Lemon Grass).

Common in many of our gardens, cultivated for the fine fragrance of its leaves.

A. nardus is the sweet-scented grass from which citronella oil is distilled.

PENNISSETUM RUPPELLIANUM (Purple Fountain Grass).

This is amongst the finest and most graceful of grasses, producing a profusion of most lovely spikes on long, slender stems.

P. macrurum is very like Pampas grass. *P. longistylum* is a native of Abyssinia, and is one of the most elegant grasses. It has arched leaves and gracefully-curving, plume-like spikes, rising above the leaves. Very ornamental either alone or in groups.

THE ROCKERY.

It is only in gardens of large extent that a rockery which shall have the appearance of natural formation can be satisfactorily constructed. Still, even in a comparatively small garden, by attention to certain rules, a small and effective rockery may be made in some secluded part. The surroundings of a rockery should be in harmony with its rustic character; neither closely-mown grass nor smooth gravel are admissible in contact with it. If a path is necessary, it should be merely an irregular footpath, formed of some coarse material.

In forming a rockery the first thing to be done is to lay down a good body of suitable soil, shaped to design; then the stones, which should be of different sizes, bedded into it at various depths, odd ones, and groups of threes, being placed outside the general design. The stones should, as a general rule, be laid on their flat sides; only in a very few instances, to give variety, should two or three be thrown together, one resting on another, or with their edges, or points upwards. They should all be of the same geological formation, but may vary as much as possible in size and shape. Products of art, such as scoriae, stucco, and the like, or pieces of stone cemented together, are altogether inadmissible, it being always borne in mind that the primary object of a rock-work is the growth of plants, and not the mere display of a heap of stones. The surface on which the rockery is placed may be also varied by excavating it into a hollow here and there.

An artificial rockery, that is given the appearance of upholding a bank of earth, should be well backed by a dense mass of evergreens, so that it may not seem to be a sham. The plants selected for putting in the rockery should include a large proportion of drooping, trailing, creeping, and climbing species. For the latter a few forked stems of trees of moderate height might be fixed at intervals. The above is taken from Adamson's "Australian Gardener."

Mr. Adamson further recommends the following lists of the kinds of plants most suitable for the purpose:—

1. TALL SHRUBS.

These for the highest parts:—Among conifers are the genus *Callitris*, all species; *Casuarina*, all species; *Juniperus hibernica*, *J. Oxycedrus*, *J. phœnicia*, and *J. chinensis*; *Retinospora filifera*, *R. obtusa*, *R. pisifera*, *Thujaopsis borealis*, *Widdringtonia cupressoides*.

Amongst other shrubs:—*Acmena*, all species; *Agonis flexuosa*, *Backhousia myrtifolia*, *Chamaerops Fortunei*, *Doryanthus excelsa*, *Dracæna australis*, *D. nutans*, *Eugenia*, all species; *Yucca gloriosa*, *Rhus typhina*. The following are of drooping habit:—*Cytisus filipes*, *Genista monosperma*, *Cydonia japonica*, *Deeringia*, *Garrya elliptica*, *Leycesteria formosa*, *Pittosporum Tobira*, *Raphiolepis indica*, *Rhus Cotinus*, *Ribes speciosum*, *Robinia hispida*, *Paliurus aculeata*.

2. DWARF SHRUBS.

Berberis dulcis, *Capparis spinosa*, *Helianthemum*, all species; *Clanthus puniceus*, *Escallonia rubra*, *Cotoneaster microphylla*, *Forsythia viridissima*, *F. suspensa*, *Jasminum nudiflorum*, *Rulingia parviflora*, *Vinca major*, *V. minor*.

3. CLIMBING PLANTS.

Ampelopsis hederacea, *A. japonica*; *Clematis aristata*, and other species; *Ficus stipulata*, *Hedera* (the ivy), all varieties; *Roses*, all climbing sorts; *Rubus* (the Bramble), all varieties.

In sunny situations *Agaves*, *Cacti* of all kinds, *Crassulas*, *Mesembryanthemums*, *Sempervivums*, *Sedums*, and all other succulents will feel themselves at home, while for shady situations ferns would be appropriate.

Of herbaceous plants there are not a large number that would bear the exposure of a rock-work in this climate, unless shady nooks could be found for them where such things as *Convolvulus mauritanicus*, *Saxifraga sarmentosa*, and *Linaria Cymbalaria*, would be likely to thrive.

FERNERY.

Ferns are plants that are universally admired, and, being easily grown, their cultivation has become common. Nearly all are shade-loving, and a large number are sufficiently hardy to thrive out of doors in this climate. They can be grown to a high degree of perfection in a greenhouse or an ordinary shelter shed, where they may be either planted in the open ground or grown in pots. If the shed is sufficiently large, a rockery may be formed on it, with pools, jets, and streams of water. The soil should be of good quality, enriched with vegetable mould, or much-decayed cow dung, in imitation of the natural vegetable soil of the glens or gullies in which ferns naturally luxuriate; while a compost including peat soil must be provided for those of delicate constitution. The stronger-growing species require rich feeding, and as soon as they are thoroughly established should be occasionally watered with liquid manure. The soil should not be allowed to become dry; therefore, during the season of growth heavy waterings should be given once or twice a week according to the weather. The plants should be syringed daily, or twice a day, morning or evening, during hot winds. They should be frequently examined, lest thrips or scale obtain a lodgment, which, if detected, should be immediately despatched, the thrips by means of strong soap-suds or tobacco liquor, the scale by sponging or syringing with a solution of kerosene and soft soap.

A fernery, like a rockery, should be partly or altogether hidden from the dressed parts of the garden, because, being of a rustic character, it would not harmonise with them. It might, with propriety, form a portion of the rockery, which might be terminated by the fernery. In its formation a natural glen, or fern gully, might be taken as a model for imitation; and if a stream of water

could be made to flow in a tortuous channel through the centre, a good effect would be produced. A rustic path should follow the course of the stream, partly on one side and partly on the other, crossing by means of apparently fallen boulders. As few ferns can thrive if fully exposed to the sun and wind, they must have shade and shelter, but if these cannot be obtained from trees and shrubs, then artificial means must be adopted; these generally take the form of a span frame work covered with laths or tea-tree, which, as it is anything but ornamental, and can only be looked upon as a necessary evil, should be made as light and unpretentious as possible; the covering ought to be thin, and to give increase of shade where required, climbing plants of light foliage may be trained over it in places. The dwarf sorts should be grown near the eye, and the tree ferns on the highest parts, with the exception of an occasional specimen lower down to give variety. *Dicksonia antarctica* and the New Zealand Tree Ferns require damp and shady situations, but *Alsophila australis* will succeed on dry and partly exposed places. The fernery need not be confined to ferns alone, but may have an admixture of grasses, sedges, *Phormium*, and shade-loving shrubs, such as *Griselinia* and *Coprosma*.

The following list, which might be greatly enlarged, consists of dwarf sorts that are hardy and easily cultivated out of doors:—*Adiantum assimile*, *A. Capillus Veneris*, *Aspidium aculeatum*, *A. capense*, *Asplenium bulbiferum*, *A. flabellifolium*, *A. Filixfœmina*, *A. lucidum*, *A. umbrosum* (*Allontodia australis*), *Blechnum cartilagineum*, *Cheilanthes tenuifolia*, *Davallia novae-zealandiæ*, *Dicksonia dubia*, *Doodia aspera*, *D. caudata*, *Gleichenia circinata* or *microphylla*, *G. flabellata*, *G. dicarpa*, *Lastrea*, numerous species and varieties, *Lomaria discolor* and varieties, *L. fluviatilis*, *L. lanceolata*, *L. Patersonii*, *L. procera*, *Lindsæa linearis*, *Onychium lucidum*, *Nephrodium decompositum*, *Notholaena distans*, *Pellæa falcata*, *Polypodium australe* (epiphyte), *P. Billardieri* (epiphyte), *P. punctatum*, *Pteris incisiva* (*vesper-tilionis*), *Pt. tremula*, *Pt. umbrosa*, *Pt. scaberula*, *Schizæa dichotoma*, *Scolopendrium vulgare*. The following are some of the most easily procurable Tree Ferns:—*Alsophila australis*, *A. excelsa*, *Cyathea Cunninghamsii*, *C. dealbata*, *C. medullaris*, *C. Smithii*, *Dicksonia antarctica*, *D. squarrosa*, *Todea barbara*.

THE BUSH-HOUSE.

I have already, in the introductory pages of this work, described the method of building a cheap and effective bush-house, as well as the construction of the Rockery and Fernery, but I have thought it well to enlarge further on the two latter adjuncts to the amateur's garden by adding lists of plants suitable for them, leaving it to the gardener's judgment to decide what plants require the partial shade and broken light of the Bush-house.

PALMS.

Palms constitute the most elegant and graceful family in the vegetable kingdom. Nearly all the species are admirably adapted for hall and conservatory decoration, also for plant sheds and bush-houses, whilst most of the hardier kinds do well here outside. Amongst the latter are the "Bangolas," "Fan and Cabbage Palms," "Kentias," "Cocos," "Royal and Date Palms."

They will not stand the exposure that pines will, but invariably hold their own in any situation, when once established, and there are few gardens of any size where a suitable place could not be found for some of these very beautiful plants. Palms are most beautiful and graceful when in their young condition, when the leaves are situated only a short distance from the ground; for, in the full-grown trees, the long pole-like, naked stems, it must be owned, are exceedingly ugly, so much so, indeed, as to detract altogether from the beauty of the handsome head of fronds by which they are surmounted. They are propagated by seed, which may be sown in pots. The young plants are put out in the situations intended for them when about a foot and a half high.

The best plants are those that are raised from seed. The young seedlings can be readily transplanted without injury, and can be moved from one sized pot to another without any danger. They are very difficult to shift from the open ground after the plants have attained any size, and this is the reason why so many of the plants obtained from the scrubs around Brisbane fail to grow. It is a common failing of gardeners to wish for a large plant to start with, and generally speaking as large a plant as possible is dug up. The best sized plant to take is one that has made the second leaf, and if this is done during the summer months, the roots being placed between two pieces of damp peat, very few losses will result.

Mr. Philip Mac Mahon, Director of Forests, when in charge of the Brisbane Botanic Gardens, used to collect large quantities of palms in the Blackall Range and elsewhere. His method was to insert a deep box with three sides underneath the young growing palms, which were then left undisturbed for 12 months, at the end of which time the boxes were lifted with the palm well established, and undisturbed by removal.

The following notes on growing palms are by a writer in the "Brisbane Courier," under the *nom de plume* "Hortulanus":—

The compost most suitable for palms consists of one part heavy loam, one part leaf mould, and one part sharp sand, with a good sprinkling of bone-meal. The pots should be well drained with plenty of broken crocks, with a layer of cocoanut fibre or broken charcoal on top to prevent it choking. Palm seed should be sown as fresh as possible in shallow boxes early in the spring and covered with a sheet of glass. The young plants can be worked into small pots as soon as they have made the second leaf. Always move them during the summer months; never under any circumstances disturb them during the winter. As the plants grow they should be transferred to larger pots: use a pot one size larger each time, and on no account shift from a small pot to a large one. Palms should be kept in a small-sized pot as long as possible, and if nice shapely specimens are desired, they must be retarded as much as possible. Only repot when it is plainly evident that the plant has outgrown the pot it is in. A fine specimen can be grown in a 5-in. pot, and kept in full growth and vigour for a long time if properly looked after. When the plants have been placed in pots over 5 in. they will only require repotting every two years; but once every six months remove a considerable amount of the top soil and refill with rich compost of one part leaf mould and one part well rotted stable manure, and a good sprinkling of bone-dust. The drainage will require careful watching, as palm roots form a matted ball at the bottom of the pot, which has the effect of choking the drainage. In many instances this can be temporarily relieved by knocking the plant out of the pot, and after placing a fresh crock over the hole in the pot replace. But once the roots of the plant choke the drainage, it will be advisable to repot as early as convenient. When transferring from one pot to another, remove all the old pieces of drainage from among the roots, look over the roots well, and cut away with a sharp knife any diseased or damaged ones. If the roots are healthy and clean it is inadvisable to disturb them more than is actually necessary; but just place the ball of roots and soil in a size larger pot. Should it be observed that the roots are affected with disease (the one most prevalent among palms is a bluey-white mould which grows all over the roots), carefully wash every particle of soil and disease off with clean water. Cut off any roots that are broken or cracked, as it is in places such as this that the disease lurks, and should the roots be very closely matted remove a number so as to let the remainder have more room to spread. Replace the plant in fresh soil, and water sparingly until it has commenced to make fresh growth. Some varieties, especially the Phoenix, send their roots straight down to the bottom of the pot, and will lift the base of the plant out of the soil. It is advisable when repotting plants of this nature to cut away a considerable number of the old roots. The plants are subject to numerous leaf pests and diseases. A bright

green grub will often attack the leaves and quickly destroy the foliage. This grub can be easily discovered from the habit it has of rolling the leaves round it. Hand-picking is the only remedy. They are also subject to a number of scale pests, and the leaves must be regularly sponged with weak kerosene emulsion or Gishurst compound. When sponging, place the pot on its side on the bench, and be careful that none of the wash runs down into the soil at the base of the plant. Palms will stand for a long time in the house if regularly watered, but they should never be left long in a strong draught. They do best in a bushhouse, and a week's spell in the rooms of the house is long enough, when they should be returned to the bushhouse for a rest. There are a great number of varieties which can be grown as pot plants. The Kentias are the ones most commonly grown, and make very handsome specimens. *Kentia Fosteriana* is easily grown, and from its earliest stages makes a handsome specimen. As a large plant for decorative purposes it has no equal, and a big plant can be grown in a small-sized pot. *Kentia Belmoreana* is somewhat similar, but has a finer leaf, and is more suitable for table decoration. *Cocos Weddelliana* is the most elegant and handsome of all the smaller palms. Its slender, erect stem is freely furnished with graceful arching leaves of a rich green colour. This variety is slow of growth, but is beautiful even as a very small plant, and it is not subject to disease or insect pests, but if not protected is apt to be injured by a very cold snap. It really requires the protection of a bit of glass during the very cold weather. The Arecas are a large family, the most commonly grown being *Areca, lutescens, sapida, and baueri*. All make handsome plants, and are quite hardy. The best varieties of the Phoenix family for pot plant culture are *farinifera, rupicola, sylvestris, and acaulis*. *Livistona Chinensis* is the finest of the fan-shaped varieties suitable for pot plants. As this family of plants are mostly of a tropical or sub-tropical habit of growth, it is not desirable to move or interfere with them during cold weather; this is a common cause of trouble with these plants. Many persons replant or repot them too early, and the plants have not had time to recover before they get a cold night or two, and the loss of the palm almost is invariably the result. In this climate it is soon enough to start moving them about the middle of October. As soon as one or two simple rules are understood, palms are very easy of cultivation as pot plants.

SOME FACTS AND FANCIES OF THE GARDEN.

Read at a monthly meeting of the Victorian Horticultural Improvement Society, Melbourne, 21st January, 1909, by Ambrose C. Neate, Malvern, Vic.

A PLEASING OUTLOOK.

The garden is, or should become, a perennial source of pleasure to both old and young, to rich and poor; and can be made most enchanting, according to soil, situation, and climate. It gives a family home its most attractive setting, especially in a fitful climate such as ours is, if due attention be given to the tasteful introduction of tropical foliage, such as of various palms, Cordylines, Rice-paper plants, Bamboos and Bamboo reeds (*Arundo*); combining in all bold contrasts of form, leafage, and colour; all being set off by plentifully swarded stretches of Buffalo or Kentucky blue grasses—sloping off into either walks or water marginings. This principle, as applied to large public or private grounds, is most captivating, and if generously embodied by the landscape artist in many varieties of detail will fill up the poet's ideal that:—

“All are but parts of one stupendous whole.” (POPE.)

And it may be so applied to make even a villa garden appear at least twice its measured size—by a skilful blending in it of both fact and fancy: giving ideal picturings both of natural wildness with the refining influence of art combined.

I am sure you will agree with me that these views have been very fully carried into effect in conjunction with bewitchingly curved and sweeping walks

both in our Botanical and other of our city public gardens,* as well as in many private grounds. I need not particularise, as the ever-increasing evidences are under our gaze on every hand—of successful culture, pleasing effects, and healthful openness, combined with grateful shadings. And these, often commingled with water mirrorings, are surpassingly testified to by both artists of the pen and pencil with the work also of their true yoke-fellow—that man with an eye for the beautiful, who, with his camera, can produce a picture of land and water, mountain and glen, light and shade in our clear air, second to none in any other clime in the universe!

DIVERSITY IN UNITY.

By all means let us have infinite variety of both flowers and foliage; let our home-gardens contain special examples of leading lines, such as Cannas (foliage and flowers), coloured Cordylines (Palm lilies), and Arundo (Bamboo reeds) of silvery hue; Hydrangeas and Coprosmas (lighter forms), and do not fail to include *Euonymus Japonicus* (silvery and golden), and others of that class. Then, of course, we must have carnations, chrysanthemums, also roses—climbing, standard, and shrubby forms. And we may find it useful to ornament dry and rocky or declivitous places with Portulacas and Mesembryanthemums (witness the Alexandra drive for glorious exhibitions of the last named). Whilst for our fences, trellises, and outhouses, we may usefully cover them with Snail Creepers (*Phaseolus Caracalla*); Virginia Creepers (various forms of Ampelopsis); *Tecoma Guilfoylei*, and *T. McKenii*; Ivy-leaf Pelargoniums in variety, also *Mandevilla suaveolens*, *Tecomas—Capensis* and *Smithii*.

Of course, it goes without the need of testimony that every lover of a garden will have as full an assortment as possible of bulbous, tuberous, and other items, such as Gladiolus and Jonquils; Agapanthus (white and blue); also *Amaryllis Johnsonii*, &c.; then annuals, &c., such as Campanulas, dwarf Snapdragons, Phloxes (annual and perennial), Zinnias, and Asters, beside a score or so of others of small habit. All to give variety in the colouring, as well as flowers for the table. If the room be too limited, then it may be well to have but few striking plants for colour and effect. Therefore, perhaps those who pass by will say to themselves (parodying the poet)—

“Though much in little is the plot we see,
It represents Queen Flora’s majesty.”

POETIC AND ARTISTIC BLENDINGS.

Cowper, who, by the way, dearly loved garden ideals, wrote—“There is a pleasure in poetic pains, which only poets know”; and we, too, may well apply this truism to time spent by way of recreation in the garden! Indeed, poetry is, as ever, the handmaid of Art, and both are expressed truly by the loving efforts given by the home garden enthusiast, who by filling up so profitably many hours of spare time may cause many a gleam of brightness—“many a gem of spotless ray serene”—to glisten as the result of his or her fond attentions in or out of season.

Says the Rev. James Hervey, A.M. (Meditations), “Reflections on a Flower Garden”:—“What a living picture is here of the beneficial effects of industry! by it, this neat spot is an image of Eden. Here is all that can entertain the mind or regale the smell. Whereas, without cultivation, this sweet garden had been a desolate wilderness. Vile thistles had made it loathsome, and tangled briars inaccessible. Without cultivation, it might have been a nest of serpents and the horrid haunt of other venomous creatures. But the spade and pruning knife in the hands of industry have improved it into a sort of terrestrial paradise.”

The value of easily curved walks of an S pattern is in the more ready blending therewith of sloping ground, general bold groupings of plants, and open grassy spaces. A walk of this class should always give a reason for the

* The Fitzroy Gardens specially should be named in connection with the late Mr. John Guilfoyle, who died very recently. He effected many improvements therein.

sweep—viz., by being made to skirt a Rockery or clump of trees, or even a single specimen Palm or other tree, and should not let its terminating point be seen; indeed, there should be a succession of surprises! Let such a walk lead circuitously to or from a gateway, to or from a house or rustic structure, or lose itself in going closely past an assumed (therefore created) obstacle, right into a dell—on again to a public way—approaching it with marked suddenness. There should be a complete blending of Art with Nature in all picturesque garden work as far as is possible. Well, therefore, may each one, fond of his or her garden, and after much gratifying success therein, say with Landor:—

“Nature I loved, and, next to Nature, Art;
I warmed both hands in the fire of life!”

In other words, “Let your love of Art find its expression in the sympathetic efforts of your hands, as the outcome of your ennobled fancy, combined with and testifying to the facts of experiences.”

EXPERIMENTAL JOTTINGS.

No true lover of a garden ever became proficient in any sense of the word who did not either test the advice tendered or plan out some new way for himself. Every garden should teem with evidences of experiment. Some plants, do what you may, will not thrive in a given sunny or shady, windy or sheltered spot; and they may not love either a shady or clayey soil—e.g., I have a *Lilium Auratum* and an *Amaryllis Johnsonii*, both of which suffered severely from the heat of last summer; these were with some others of a bulbous nature removed to a southern and shady position, under shelter of the brick house wall, and they are bidding fair to give floral appreciation of the change. Then I had to cancel such hardy items as *Linarias* in favour of dwarf Snapdragons on a hot and exposed western border, fringing the same with those glorious though short-lived *Portulacas* (*P. grandiflora*). Then, as to bigger forms of vegetation, what excellent effects can result from the multiplying by root pieces of Rice-paper plants (*Aralia papyrifera*), and also with the “Chinese tree of heaven” (*Ailanthus glandulosa*). A plant of this was put in, where its summer shelter was much needed—when no thicker than a lead pencil, and a mere twig in height; well, in 14 months, by care as to its uprightness of growth, it developed to a total height of 12 ft. by actual thickness of stem at 4 ft. from the ground of 2 in. (diam.). It is now surmounted with a fine wealth of frondage to be usefully “dropped” in favour of “more light” in winter, &c. But, beware where you put such in a small garden. It is a useful *servant*, but may sometimes become a bad *master*. NOTE.—It “stools” very much unless checked and guided (with limitations).

Pepper trees (*Schinus molle*) have also received both praise and blame as tenants of the garden, but nothing, in my judgment, can equal their gratifying shade, and the use to which they can be put for hiding out ugliness in back premises. Certainly no plants lend themselves more amiably to the efforts of the pruner—expressing, indeed, their gratitude (so to speak) by fringings and pendulous branchings of a most graceful kind. They grow, too, so rapidly, and stand heat where nothing else would do so well.

That “standard” and other forms of rose trees have been successfully transplanted in summer time, proves the wisdom of further trials, but only in case of necessity, of course. In November last a plant of *Saffranot* had to be taken away from its place—it would have been destroyed—and, being purposely denuded of foliage, the roots were spread out, wagon-wheel like, and dry earth was simply poured in around the stem and over the roots and rootlets—then well incorporated with them. A “basin” of soil was then ringed round the plant, whilst a thorough soaking of water was given and repeated, with the result of renewed leafage, growth, and evidence of flowering. A *Zinnia elegans* of good size, having been dragged up by the roots, was brought me by a little girl some time back in summer time. It had very fine blooms. Being nipped back, it was planted again as above stated, and

grew well, yielding quite a crop of flowers. The same plan was also applied to Mignonette, &c., whilst a small lawn was repaired with Buffalo grass in the same way, and success followed.

Now, many years since, there was in the Botanic Gardens a piece of ground called the "experimental bank." In this plot the late Baron Von Mueller placed various kinds of utilitarian trees and shrubs, such as the "Queensland Nut" (*Macadamia*), Guavas, Olives, Basket (and other) Willows, Pea Nuts (*Arachis*), and many other things of interest for supplementary culture, and he skirted the top of the bank with Buffalo grass (*Stenotaphrum glabrum*) as an edging. In this spot a young office assistant was sometimes engaged. Well, one day the junior thought it wise to trim and shape this band of grass. (This species was then rare enough in the Gardens, and almost new to Victorian lawns, &c.). But the Baron happened to come along soon after the operation, and not approving, as his extended (or uptended) arms testified, he almost pathetically cried out—fearing the extermination of the edging—Oh! my beautiful Buffalo—my beautiful Buffalo!!

No one ever thinks now of attempting to move (transplant) any of our Australian gum trees, yet Mr. Guilfoyle once had a good "try," for he found a very likely example (I think it was *Eucalyptus doratoxyton*, 18 ft. in height), which had grown on a slope, and right upon a bed of cement like gravel, thus its roots extended horizontally. Well, it came away all right, and was replanted, but neither care then nor after attention could save it, and it gradually died off. In any case, in its old position, it must have been sacrificed—being in the way of building improvements. This dictum seems to apply also to most, if not all, of the Acacias, to very many of the Proteaceæ (including Banksias or Honeysuckles), and, if of any size, all the She Oaks (Casuarinæ), excepting, perhaps, many young and small growing—mostly herbaceous—plants, where they can be lifted with "balls" of earth. There are many examples of these in the Botanic Gardens—successfully transferred from the Grampians and other homes of indigenous species.

AUSTRALIAN PLANTS FOR "HOME" GARDENS.

What can exceed in beauty the various elegant forms and many shades of colour, as shown by the varieties of *Eucalyptus ficifolia*! and, we might add, the white and pink forms of *E. calophylla*, whilst there are many other examples of gums well worthy of a larger place in our park lands, &c., than now prevails.

The old fable, as in the school books of 50 or 60 years ago, stated that all "Australian flowers have no scent." But our present knowledge of the facts proves that we have many examples of odorous flowers—viz., troops of Acacias (over 300 species); and one has only to name the *Boronia megastigma* to smile on account of the error referred to. Then, as to colour, one has only to think of the Waratah of New South Wales (*Telopia speciosissima*), and that of Tasmania (*T. truncata*), and to remember many of the Proteaceæ, such as Grevillias, Hakeas (e.g., *B. laurina*), and the "Native Heath" also (*Epaeris*); then the Hollyhock-like Hibiscus—*H. splendens* and *H. heterophyllus*. And would that we had in cultivation (for it should do well) that lovely Swainsonia—McCullochiana (Rose-pink) of Western Australia. It was introduced to cultivation by Baron Von Mueller in, I think, 1869 or 1870, but he did not succeed in keeping it, and the nurseryman who had it supplied to him did not succeed in placing it—or only did so for a time. (NOTE.—Seed should be available from a West Australian nurseryman, &c.)

The Order *Swainsonia* was named after the late Mr. W. Swainson, F.R.S., and contains the kinds (*S. lessertifolia* is one of them) that poison horses and stock. I have here a printed copy of a Botanical Report by him, submitted to the Legislative Council by His Excellency's command, 1st November, 1853. This document treats of the native plants of Port Phillip (Victoria), and contains but little, if anything, in the way of helpful fact, I

am sorry to say. Though the compiler claimed to have had no books of reference, yet he gave both names and descriptions with much certainty and in profusion. I quote a few examples:—

- (1) *Eucalyptide* (properly Eucalypts) = 1,520 species, &c. *Fact*: Only 150 species (say), and perhaps as many varieties.
- (2) *Casuarine*, called by him "true pines" (?) = 213 species. *Fact*: Not more than 20 or 25 species known to be in existence.

No wonder a great Botanical Authority in England termed Mr. Swainson's descriptions by a word of emphatic disapproval, so the Baron once told me; but I did not just then know the direct reason until I had seen the "Report"—as to the plants "described, collected, and handed to the Curator of the Botanical Gardens"—the late Mr. John Dallachy (whom I knew in the "fifties" and "sixties.") (NOTE.—Mr. Swainson's qualifications lay, it would seem, more in the way of Zoology than Botany, *vide facts*, "Vict. Botanists," J. H. Maiden, F.L.S., in "Vict. Naturalist," 5th November, 1908).

I can only add, as to the long years of Botanical discovery since 1853, that they prove how valuable have been the labours of talented men like Baron Von Mueller (Victoria), F. M. Bailey, F.L.S. (Queensland), W. Woolls (New South Wales), J. H. Maiden, F.L.S. (Director, Botanic Gardens, Sydney, New South Wales), and many others, who have given unquestioned and valuable elucidations bearing on the indigenous plant life of Australia.

PICTORIAL REFERENCES TO OUR NATIVE FLORA.

We may (by time limit) only touch the margin of this "Field of the Cloth of Gold," remarking that when Mrs. Meredith illustrated, many years since, both with pen and pencil, by artistic picturings of the plants of Tasmania, she did a valuable duty to posterity in her two volumes, "Bush Friends." (I have the names, &c., of all the plants she describes in my M.S. copy.) Then there is Miss Charsley's Australian Flowers (in the Public Library, I think). It contains many beautifully coloured plates, all from her own paintings (and I was reminded by one of the members of this (Vict. Hort. Impt.) Society of Mrs. Rowan's fine sketches of our Australian plants, after the reading of the paper). Then there is the work of Miss North, a most excellent series of Australian and other (tropic) pictures, for which a special building has been erected (Kew Royal Botanic Gardens, London). It may also interest lovers of our wild flowers to know that a lady well known to my family circle—Miss Allen—resident in South Yarra, was a skilled delineator of many New South Wales plants, when on travel, both as to actual form and colouring. Would that there were many more such ladies of leisure who could thus improve the time with entertaining side pleasures such as described, and put on record such cheery evidences as these ladies have done!

In keeping with these remarks, let me invite your attention to an unrivalled collection of native plants (some of you may not be aware of it (?)) formed many years since by the present Director in the Botanic Gardens. It occupies a considerable space skirting the southern and western sides of the enclosure. There are besides many other examples—borders, classified groups, on lawns and otherwise. It is of large interest, as are other classes of plants, to students of Pharmacy and others.

As to private lands and public gardens and parks in mild climates, everywhere what fine effects could be produced by the groupings of Australian trees and shrubs—*e.g.*, *Eucalyptus citriodora* (Lemon-Scented Gum), silver barked, against *E. leucorylon*, almost black barked: *E. ficifolia*, which, with its blaze of red or pink flowers, against specimens of *Grevillea robusta*, having golden trusses of bloom. Then think of the "Kootamundra Wattle" (*Acacia Bailejana*), with its glaucous foliage and golden spring flowers, in conjunction with the fine foliage of the "Norfolk Island tree fern" (*Alsophila excelsa*); and, by addition, let some such plants as the "Queensland Spear Lilies"—*Doryanthes excelsa* and *D. Palmeri*—be used, to give the pleasing variety of their bold foliage.

OUR SEASONS.

It may be well to remember specially, when studying the helpful horticultural literature of the British and South Europe mother lands, that you must almost reverse the instructions, seeing both here and "at home" there are direct opposites of summer and winter as with the other two seasons. So, if your English garden guide book says sow or plant in April or May, you must perforce think of September or October in Australia!

Several years since (1893) the late highly-esteemed Government Astronomer and Director of the Observatory, Melbourne, Mr. R. L. J. Ellery, F.R.S., gave me the following helpful note:—

"The shortest day is the same for all Australasia, and nearly the same within a few hours for every year. The seasons also may be taken as similar to Melbourne, that is—

Spring begins 23rd September;
 Summer begins 21st December;
 Autumn begins 20th May, or 20th March in Queensland;
 Winter begins 21st June, or 24th June in Queensland.

Though we can do so much here, which would be impossible out of season, say, in Great Britain or in other parts of Europe, &c., it will be well to follow the usual instructions as to deciduous trees and shrubs—viz., as to Autumn, Winter, or Spring planting and sowing (and as affects annuals and perennials in the open in Spring time). But, with regard to evergreens, much liberty may be taken, allowing that the roots must be well spread out, well intermixed with the soil, and plentifully dosed with water. And wonders can be and have been done (as before referred to in this paper) with lawns, special styles of planting, and landscape garden improvement, nearly all the year round here under skilled guidance—hot summer days alone excepted—to produce effects in a few days or weeks that would be impossible otherwise, or only attainable by many years of patient waiting. But, then, these things are only to be done in a large way by mental and physical skill, and must be left very much to millionaires and public bodies, who in this way have power to accomplish what would be left undone without the power of the purse! (Many of us do not possess this.)

SOME CLOSING WORDS.

1. Now is an excellent time to put in live, *i.e.*, growing pieces of Buffalo grass for lawns; and it is generally most satisfactory to do this sort of work, say, from October to January.

2. The very best for general lawn work next to the foregoing is the "Kentucky Blue Grass" for lasting surfaces in this climate. It may be either sown or freely transplanted (if you have a surplus stock) in any moist weather. It "stools" well, but does not run all over the garden as does the Couch (or Doub) grass.

3. Do not be afraid, however, of the interspersion of the "Couch"—it fills up well and helpfully—in bare or difficult spots, of course, away from the borders; but take care! and resist as if it were the very plague those dreadful underground roots and overground runners of the native Buffalo grass (*Paspalum distichum*), excellent, by the way, for swampy places and river or lake embankments to prevent action of flood water. In a lawn it is an awful scourge, as your borders and flower beds will soon inform you, seeing every joint will multiply with great rapidity!

4. And, finally, always keep your lawn as a splendid emerald framing, in which to set your floral treasures out to the best advantages of form and colour. No treatise, lecturette, or essay can ever exhaust all that could be said of the experiences of all real owners of a garden. When treading noiselessly on the velvet sward, we may look very cheerily into the faces of our gentle constituents with some thought of their great Originator, and say—

"Your voiceless lips, O Flowers, are living preachers!"

Forestry.

FORESTS OF CHINA.

In the February number of the Journal we gave a short extract on the forests of Japan from the Journal of Agriculture of Natal. That Journal contrasts the condition of forestry in that progressive country with the position in China.

"China," says the writer of the paper alluded to, "holds a unique position as the only civilised country which has persistently destroyed its forests. What forestry has done in other countries stands out in bold relief against the background of China, whose hills have been largely stripped clean of all vegetation, and whose soil is almost completely at the mercy of floods. Trees have been left only when they could not be reached. Almost the sole use for lumber is the manufacture of coffins. The heavy 2 or 3 in. planks for this purpose are so scarce, and the cost of transporting them by coolies is so high, that they sell for 8s. 4d. and 12s. 6d. apiece.

"Nowhere in the world is the forest cleaned off down to the very soil as it is in China. When the trees are gone, the saplings, the shrubs, and even the herbage are taken. Slender poles are used to build houses; inconsiderable shrubs are turned into charcoal. In the lower mountains of North-eastern China, where the stripping process has reached its extreme phase, there is no trace of anything worthy of the name of forest. In the graveyards and courts of the temples a few aged cedars have been preserved by the force of public opinion, and poplars and fruit trees planted about dwellings are protected as private property by the peasant owners.

"In the province of Shantung, where deforestation is practically complete, fuel and fodder for cattle are literally scratched from the hill sides by boys, who go out from villages with their iron rakes in autumn to secure winter supplies. Grazing animals, searching every ledge and crevice, crop the remaining grass down to the very roots.

"A dearth of wood is not the only forlorn result of forest devastation; a dearth of water and the ruin of the soil follow in its train. In Western China, where forest destruction is not yet complete, enough vegetation covers the mountains to retard the run-off of the rains, and return sufficient moisture to the lower levels, where it can be reached by the roots of crops, and where springs are numerous. But, on the waste hills of Eastern China, the rains rush off from the barren surfaces, flooding the valleys, ruining the fields, and destroying towns and villages. No water is retained at the higher levels, so that none is fed underground to the lower soils or to the springs. As a result, even on the plains, the water level is too far beneath the surface to be used. Without irrigation and the ingenious terracing of hill sides, by which the rains are made to wash the soil into thousands of miniature fields whose edges are propped up by the walls, agriculture would be entirely impossible. Even irrigation calls for the immense labour of drawing the water from wells.

"In a word, the Chinese, by forest waste, have brought upon themselves two costly calamities—floods and water famine. The forest school lately opened at Mukden is the first step in the direction of repairing this waste, so far as it may now be repaired."

This woeful state of affairs should set Queenslanders thinking of what may be the result of the clearing of scrub lands, and of ringbarking thousands of acres of forest land, which have been vigorously prosecuted for many years.

In this connection, we think it well to republish a paper we wrote in November, 1900, on the subject of

FORESTS AND MOISTURE.

By THE EDITOR.

Although much has been written on the question of the connection between forests and rainfall, and many arguments, *pro* and *con*, have been brought forward, we seem to be no nearer to unanimity on this important subject. But there are cases in which argument brings enlightenment. It is easy to affirm that forests do not increase the rainfall or moisture of a district, but there are local conditions which have to be taken into consideration which materially modify any statement in favour of or against increased rainfall due to the timber covering of the soil. It needs no very acute reasoning to show, by an examination of our own forests and scrubs, that they are important factors in restraining evaporation, retarding or even preventing heavy floods, and the washing away of hill-sides, and consequently retaining the supplies of rivers and springs in the bowels of the earth. So much has been granted by all who have scientifically considered the matter. Compare a clear, open eucalyptus forest with no undergrowth with a dense vine scrub. The winds have free play through the former, whilst the heavy timber and undergrowth of the latter present an almost impassable barrier to even heavy gales. What is wind? Wind is air in motion, and air in motion is a very rapid worker. As it sweeps over the bare surface of land or water, it carries away with it more moisture than is evaporated by the heat of the sun. Still air, on the contrary, very slowly absorbs moisture. The air in the scrubs is still, and hence the moisture in the thick carpet of humus in such places is very slowly evaporated, and is being constantly renewed by heavy dews and showers of rain, which supply far more than is carried off in the air. This gives the superabundant water time to sink slowly into subterranean reservoirs, which, being constantly saturated, are able to keep up the supplies drawn upon by streams and springs. When heavy rain is long continued, when there is little or no undergrowth, the surplus water rushes off the sun-dried surface of the soil, pours into the creeks, and swells their water faster than the rivers or lakes to which they are tributary can carry them off. Hence arise often devastating floods. In the scrubs, on the other hand, the flood waters are retarded by the undergrowth and the mat of roots traversing the soil like a close network, and before they can get away to the creeks in injurious bodies they sink through the porous soil to the regions below, and so are prevented from flooding the low-lying country.

Usually after heavy rain in Queensland, strong, drying, westerly winds sweep over the country, and the open forest is rapidly deprived of much of the moisture which has remained in the soil, and is left in perhaps a worse position than before the rains. The scrubs will not permit the drying winds to sweep through them, so that the moisture is retained in the soil. The still air above it absorbs this moisture very slowly until it has become saturated. Once the point of saturation is reached, evaporation ceases, and under certain conditions condensation and precipitation follow. This precipitation may take the form of heavy dews or of *rain*. In this sense, then, it may be asserted that forests increase the rainfall. Moist air being lighter than dry heated air, the former will ascend and assist in forming rain-clouds, which, when fully charged, and reaching a stratum favourable to condensation, must fall in the form of rain, but not necessarily in the district where they were formed. Having risen above the protecting influence of the scrub, they are caught by the winds and swept away, joining other clouds on their way. Perhaps they reach a high range, on which they impinge, and rolling upwards reach a cooler atmosphere, and at once condense and fall in grateful showers, perhaps 200 or 300 miles from the forests which gave them birth.

Professor R. C. Kedzie, Chemist of the Michigan Agricultural College, tried an experiment to obtain some measure of the relative rapidity of evaporation in a draught, and in comparatively still air. The air in one part of the chemical lecture-room was so nearly still that a feather would not move perceptibly. By opening windows in another part of the room, a strong draught could be obtained at one window, the wind blowing 12 miles an hour. Two square pieces of Turkish towelling of the same size were thoroughly wetted, just short of dripping, then weighed separately, one suspended in the still air of the room for an hour; while the other was similarly hung in the draught by the window, or in the mouth of the ventilating shaft. Both were left for an hour, then weighed again, and the loss in weight showed the amount of water evaporated in each case. The trial was made seven times, with the result that the evaporation was four times greater in the draught than in the still air. The actual amount evaporated was not the same for each hour, but the ratio of evaporation was almost identical in the whole series, viz. :—Four times as much in the draught as took place in the still air.

The reason for this is not hard to find. A volume of perfectly still air surrounding a wet body will take up moisture with progressive slowness till the air is saturated; but, if this damp air is blown away and replaced by relatively dry air, evaporation will go on with increased rapidity, and if the air is constantly renewed, as in a draught of wind, the evaporation will be more rapid. Every washerwoman knows that the clothes will soon blow dry when hung out in a stiff breeze, but will take hours if lined up indoors.

The principle of the professor's laboratory experiment, he says, will hold in the broad open of Nature. The air in contact with the moist ground will take up water till it is saturated, and then evaporation will be suspended, provided the air remains still and undisturbed. But, if this bottom air is swept away by wind, evaporation will be renewed, and the drying of the soil will again go on. The influence of trees, shrubs, and even of the grass in preserving in some degree this shallow pool of quiet air at the ground-level, and thus diminishing evaporation from the soil, may seem a trifling matter at first thought, but becomes of great moment on the large scale of Nature.

From this it will be seen that my theory is fully borne out by Professor Kedzie.

DEPLETION OF FORESTS IN NEW SOUTH WALES.

The Engineer-in-Chief for Railways, in New South Wales, Mr. H. Deane, has pointed out, in a paper prepared at the instance of the Minister for Works, the ever-increasing scarcity of timber suitable for railway sleepers, bridges, buildings, &c. He says:—

The forests have now almost been entirely exhausted of timber anywhere within reasonable distance from the means of obtaining railway and steamship transport. Timber-getters and sawmill owners have to push further back into the country to obtain supplies for the constantly increasing demand. Especially is this the case with ironbark, but to a greater extent it also applies to other hardwoods.

And the time is not far off when, instead of New South Wales being looked upon as a country with a superabundant area of forests, it will reach the condition of those countries where more expensive materials have to be used for construction in substitution for timber.

The importance of this step is all the greater when it is considered how large a quantity of the colony's most valuable timbers are exported to other parts of the world, and of late particularly to New Zealand, and that, with the exception of the wages paid to timber-getters and the profits of timber merchants, the colony gains nothing herself, but is gradually being drained of one of her most valuable assets, and no steps are being taken to reforest the districts as they become exhausted.

The ignorance of the benefits to be derived from proper management of the forests is very remarkable. We are possessed of timber which in strength

and durability can vie with the products of all the world, and a large revenue could be made out of it. Forestry is, as has been happily said by Professor Bailey Balfour, a division of rural economy which ought to be the basis of a large national industry.

Forest conservation does not mean that no trees shall be cut down, but that the forests shall be cultivated as any other crop, and not wasted. Steps should be taken to prevent the spread of fire and the browsing of animals of all sorts on growing forests.

The matter is one generally for the State to take up; yet there are immense tracts under private control which would pay better as forest than as grazing land; and if proper instructions could be given, suitable schools of forestry instituted, men could be trained both for the employment of the State and to assist private owners. As the existence of even young plantations, which only their followers will reap the benefit of, will mean the growth of to them an important asset, landowners should be taught to see that it is in the interests of their property to plant and conserve.

It is perfectly clear that, if on the forest land of the eastern slopes of the main range, where such land might be worth 1s. per acre for grazing purposes, it will pay to grow timber, then, in the interior, near the railways, the poor ridges, which are not worth 1d. per acre, would, if put under cultivation for trees, yield a very handsome profit indeed.

But it must be understood this expectation can only be realised if care is taken in growing the trees. They must be started in nurseries, planted out, and, until they have grown to a considerable size, must be properly fenced off, and protected from the browsing and ravages of animals and man. Strict measures must also be taken to preserve them from injury or destruction by bush fires.

It is certain that if proper measures were taken a profitable industry could be carried on, giving employment to large numbers of men.

A REASON FOR FOREST CONSERVANCY.

That it is high time drastic measures were taken for not only nursing our forests, but for planting trees in place of those removed, will be seen from the present condition of the vast forests of the United States. There, the total forest area is estimated in round numbers at 405,000,000 acres, or 26 per cent. of the total area of the country; Alaska, 577,390 square miles, and the Indian reservations, 31,400 square miles, not being included. The present annual requirements for consumption of forest products in the United States are, approximately, over 24,000,000,000 cub. ft., made up of the following items:—Lumber market and manufactures, 5,000,000,000 cub. ft.; railway construction, 600,000,000 cub. ft.; charcoal, 250,000,000 cub. ft.; fences, 500,000,000 cub. ft.; fuel, 18,000,000,000 cub. ft.; mining timber, 150,000,000 cub. ft. At the present rate of cutting, the remainder of forest land in the United States cannot long meet the enormous demand on its resources. Of the two most important timbers for building purposes, the merchantable white pine of the north-west and of New England is practically gone, very little remaining; and there remain of the merchantable long-leaf pine of the south only about 1,500,000,000 cub. ft. The valuable ash will probably be the first to be exhausted. Walnut and tulip trees are also on the wane. Forest fires are estimated to destroy values of about 12,000,000 dollars annually, but during the year 1894 that amount was lost in two States alone—Minnesota and Wisconsin.

Most of the States have awakened to the danger of the extinction of their forests, and have special commissions for their forestry laws. There also exists a national organisation known as the American Forestry Association,

composed of delegates from all the States, which meets annually. In forty-four States the legislatures have striven to encourage tree-planting by appointing a certain day in the year, known as Arbor Day, for the voluntary planting of trees by the people. In Queensland we also have established an Arbor Day, but only for the beautifying of State school premises by the pupils. In the United States tree-planting has for its object the renovation of the forests, and is a very serious business. Large areas of timbered country, amounting in the aggregate to 21,379,840 acres, have been reserved by the State, and large sums have been appropriated for their survey and protection. Now, if an immense territory like the United States, once so heavily timbered in many parts that the idea of the forest supplies ever giving out was scoffed at as absurd, is alive to the stern fact that its timbers are practically exhausted, with how much greater reason should we in Queensland set earnestly to work to regulate the cutting of our forest and scrub timber, to preserve the young plants and saplings, to aid and stimulate their growth by judicious thinning and by planting suitable trees in various localities? Our Forestry Branch of the Lands Department has only been created of late years, but we have no doubt that, when the Conservator of Forests has had time to make a thorough examination of our remaining timber supplies, he will formulate such regulations as will have the effect of promptly putting a stop to the reckless waste at present going on in all but our protected bunya forests.

Times of Sunrise and Sunset at Brisbane, 1909.

| DATE. | MAY. | | JUNE. | | JULY. | | AUGUST. | | PHASES OF THE MOON.
<small>H. M.</small> |
|-------|--------|-------|--------|-------|--------|-------|---------|-------|---|
| | Rises. | Sets. | Rises. | Sets. | Rises. | Sets. | Rises. | Sets. | |
| 1 | 6 13 | 5 16 | 6 30 | 5 0 | 6 39 | 5 3 | 6 30 | 5 18 | 5 May ○ Full Moon 10 8 p.m. |
| 2 | 6 14 | 5 16 | 6 31 | 5 0 | 6 39 | 5 4 | 6 30 | 5 19 | 13 „) Last Quarter 7 45 a.m. |
| 3 | 6 14 | 5 15 | 6 31 | 5 0 | 6 39 | 5 4 | 6 29 | 5 19 | 19 „ ● New Moon 11 42 p.m. |
| 4 | 6 15 | 5 14 | 6 32 | 5 0 | 6 39 | 5 4 | 6 29 | 5 20 | 27 „ (First Quarter 11 28 a.m. |
| 5 | 6 15 | 5 13 | 6 32 | 5 0 | 6 39 | 5 5 | 6 28 | 5 20 | |
| 6 | 6 16 | 5 13 | 6 33 | 5 0 | 6 39 | 5 5 | 6 27 | 5 21 | |
| 7 | 6 16 | 5 12 | 6 33 | 5 0 | 6 39 | 5 6 | 6 26 | 5 21 | 4 June ○ Full Moon 11 25 a.m. |
| 8 | 6 17 | 5 11 | 6 33 | 4 59 | 6 39 | 5 6 | 6 26 | 5 22 | 11 „) Last Quarter 0 43 p.m. |
| 9 | 6 18 | 5 10 | 6 34 | 4 59 | 6 39 | 5 7 | 6 25 | 5 22 | 18 „ ● New Moon 9 28 a.m. |
| 10 | 6 18 | 5 10 | 6 34 | 4 59 | 6 39 | 5 7 | 6 24 | 5 23 | 26 „ (First Quarter 4 43 „ |
| 11 | 6 19 | 5 9 | 6 35 | 4 59 | 6 39 | 5 7 | 6 23 | 5 23 | |
| 12 | 6 19 | 5 8 | 6 35 | 4 59 | 6 38 | 5 8 | 6 22 | 5 24 | |
| 13 | 6 20 | 5 8 | 6 35 | 4 59 | 6 38 | 5 8 | 6 22 | 5 24 | |
| 14 | 6 20 | 5 7 | 6 36 | 4 59 | 6 38 | 5 9 | 6 21 | 5 25 | |
| 15 | 6 21 | 5 7 | 6 36 | 5 0 | 6 38 | 5 9 | 6 20 | 5 25 | 3 July ○ Full Moon 10 17 p.m. |
| 16 | 6 22 | 5 6 | 6 37 | 5 0 | 6 37 | 5 10 | 6 19 | 5 26 | 10 „) Last Quarter 4 58 „ |
| 17 | 6 22 | 5 6 | 6 37 | 5 0 | 6 37 | 5 10 | 6 18 | 5 26 | 17 „ ● New Moon 8 45 „ |
| 18 | 6 23 | 5 5 | 6 37 | 5 0 | 6 37 | 5 11 | 6 17 | 5 27 | 25 „ (First Quarter 9 45 „ |
| 19 | 6 23 | 5 5 | 6 37 | 5 0 | 6 37 | 5 11 | 6 16 | 5 27 | |
| 20 | 6 24 | 5 4 | 6 37 | 5 0 | 6 36 | 5 12 | 6 15 | 5 28 | |
| 21 | 6 25 | 5 4 | 6 38 | 5 0 | 6 36 | 5 12 | 6 14 | 5 28 | |
| 22 | 6 25 | 5 3 | 6 38 | 5 0 | 6 36 | 5 13 | 6 13 | 5 29 | |
| 23 | 6 26 | 5 3 | 6 38 | 5 1 | 6 35 | 5 13 | 6 12 | 5 30 | 2 Aug. ○ Full Moon 7 14 a.m. |
| 24 | 6 26 | 5 3 | 6 38 | 5 1 | 6 35 | 5 14 | 6 11 | 5 31 | 8 „) Last Quarter 10 10 p.m. |
| 25 | 6 27 | 5 2 | 6 39 | 5 1 | 6 34 | 5 14 | 6 10 | 5 31 | 16 „ ● New Moon 9 55 a.m. |
| 26 | 6 27 | 5 2 | 6 39 | 5 1 | 6 34 | 5 15 | 6 9 | 5 31 | 24 „ (First Quarter 1 55 p.m. |
| 27 | 6 28 | 5 2 | 6 39 | 5 2 | 6 33 | 5 15 | 6 8 | 5 32 | |
| 28 | 6 28 | 5 1 | 6 39 | 5 2 | 6 33 | 5 16 | 6 7 | 5 32 | |
| 29 | 6 29 | 5 1 | 6 39 | 5 2 | 6 32 | 5 16 | 6 6 | 5 32 | 31 „ ○ Full Moon 3 8 „ |
| 30 | 6 29 | 5 1 | 6 39 | 5 3 | 6 32 | 5 17 | 6 5 | 5 33 | |
| 31 | 6 30 | 5 0 | ... | ... | 6 31 | 5 17 | 6 4 | 5 33 | |

BONE, BLOOD, MEATWORKS MANURES, ETC.

| | | | | | |
|---------------------------------------|--|-------|-----|-------|-------|
| Dried blood, Q.M.E., D.B.
112 | Campbell Bros. and Amos, Bundaberg | 10.80 | ... | ... | 12.54 |
| Fertiliser, Baynes Bros., Brisbane | Ditto ditto | 7.85 | ... | 21.30 | 5.63 |
| Fertiliser, C.Q.M.E. Co., Rockhampton | Wyper Bros, Bundaberg | 3.99 | ... | 20.15 | 4.13 |
| Fertiliser | C.Q.M.E. Company, Lake's Creek | 8.50 | ... | 19.90 | 6.50 |
| Fertiliser | Summerin and Co., Brisbane | 6.50 | ... | 25.00 | 3.59 |
| Bonedust, Runcorn | Campbell and Amos, Bundaberg | 6.79 | ... | 21.00 | 3.97 |
| Bonedust | Queensland Fertiliser Company, Runcorn | 5.05 | ... | 21.90 | 4.47 |
| Fertiliser | Burdekin River Meatworks | 5.50 | ... | 15.55 | 4.28 |
| Bonedust, Jordan, Zillmere | S. H. Eaves, Brisbane | 6.95 | ... | 24.20 | 3.84 |
| Peanut fertiliser | Chinese dealers, Cairns | 9.05 | ... | .84 | 6.20 |

MIXED FERTILISERS, SUPERPHOSPHATES, GUANOS, ETC.

| | | | | | | | |
|-----------------------|------------------------------------|-------|-------|-------|------|------|--|
| Superphosphate, No. 1 | Paul and Gray, Brisbane | 7.18 | 16.50 | 18.00 | ... | ... | ... |
| Superphosphate | Webster and Co., Brisbane | 10.69 | 16.80 | 18.90 | ... | ... | ... |
| Superphosphate | Milliquin and Yengarie Sugar Coy. | 11.59 | 17.50 | 19.15 | ... | ... | ... |
| Basic slag | Webster and Co., Brisbane | .59 | 15.20 | 17.00 | ... | ... | 80.0 Soluble in Wagner's ammonium citrate sol'n. |
| Cereal guano | Ditto | 12.50 | 10.78 | 13.05 | 1.40 | 3.39 | |
| Ohlendorff's guano | Gilbs, Bright, and Co., Brisbane | 3.05 | 9.50 | 12.91 | 4.05 | 6.06 | |
| Shirley's No. 3 | Paul and Gray, Brisbane | 7.50 | 14.50 | 16.25 | 2.16 | 3.25 | |
| Shirley's No. 4 | Campbell and Amos, Bundaberg | 4.21 | 14.00 | 16.00 | 4.10 | 3.95 | |
| Shirley's No. 5 | Paul and Gray, Brisbane | 4.40 | 13.20 | 15.30 | 8.75 | 3.18 | |
| Shirley's No. 7 | Ditto ditto | 6.11 | 13.00 | 16.50 | 1.35 | 1.82 | |
| Shirley's No. 11 | Ditto ditto | 5.24 | 12.50 | 14.00 | 7.49 | ... | |
| Shirley's No. 18 | Ditto ditto | 2.81 | 6.50 | 14.10 | 6.76 | 1.34 | |
| MX fertiliser | Milliquin and Yengarie Sugar Coy. | 18.51 | ... | 7.37 | 7.75 | 7.08 | |
| Yates' plant food | Burns, Twigg, and Co., Rockhampton | 6.36 | 14.45 | 17.00 | 6.70 | 2.84 | |

J. C. BRÜNNICH,

Chemist to the Department of Agriculture and Stock.

Tropical Industries.

EXTRACTION OF OIL FROM SEEDS.

From the following letter, communicated to the "Indian Trade Journal," 3rd December, 1908, by Mr. Louis Hoffmann, chemist and oil mill engineer, Calcutta, on the extraction of oil from oleaginous seeds by chemical process, it would appear that the methods at present adopted are crude, wasteful, expensive, and obsolete. In his letter he describes the "ghannies," as the plants in working operation in Calcutta are called.

"Here," he says, "is a waste of money, material, labour, and steam. We see a large area covered with some hundreds of revolving pots, each holding but a few pounds of seed. Apart from the considerable cost of such a large plant, the repairing and labour runs into large figures. A powerful (of course non-condensing) engine is the moving spirit in the show. The whole place is dirty and greasy, and looks anything but like a mill. The oil oozing out at the bottom of the grinding pots is led into a small tank, to be sold in its crude state. I have seen one native concern called an oil mill; I do not yearn to see another.

"There are also mills worked by Europeans for the purpose of crushing linseed. Even in these I noticed a great indifference as regards saving labour, cleanliness, and working on modern lines. It seems to me that it is rather a question of getting through a larger quantity than the plant is supposed to do than of making a profit by careful work. No wonder that linseed-crushing does not pay! What a difference between the plants at present in use as compared to the latest extraction plant by chemical solvents! This plant—suitable for treating oil-seeds, oil-cakes, fish bones, &c., say, 400 tons per week—consists of a 'battery' of five extracting pots, each capable of holding about 3 tons of the material to be dealt with. The shape of these pots is cylindrical, and they are arranged vertically in one line. The seed passes through a pair of horizontal rollers, and is carried up by an elevator and thence conducted by a conveyor over the 'battery.' It drops through the open manhole into the pot, and, when full, the former is tightly closed and the operation begins. In order to ensure perfect extraction, it is paramount that the material to be separated from the oil is perfectly dry. Fresh seed or cake always contain a certain amount of moisture, which must be removed, as the tiny water-cells prevent the benzine from attacking and solving the oil-bearing cells. Some makers of extraction plants of ancient date dry the material in a drying apparatus, which, apart from the cost of the plant, increases the cost of steam, and yet seldom secures perfect drying because the size of the drying plant is generally inadequate to deal with large quantities in a short time. Hence this money is mostly thrown away. Other makers do not even attempt to dry, and the result is unsatisfactory extraction. This difficulty has been solved by a new patent (Middleton-Hoffmann's) in a very ingenious and yet simple way, and the drying and extracting proceed at the same time.

"From an elevated benzine tank the solvent is led down into the bottom of the extracting pots. Inside each pot is a steam coil. As soon as the liquid benzine touches the pipes, it evaporates, and the gas penetrates the crushed seed. In about an hour the vapour works its way right through the whole pot, continuously condensing and evaporating the whole time until the whole of the contents is uniformly heated from 105 deg. to 110 deg. C. During the condensing a certain percentage of oil is solved, which collects at the bottom of the extractor; and while the heated vapour rushes through the seed, every trace of moisture is removed and carried up with the solvent vapour to be

liquefied again in the condenser and separated from the solvent by means of a separator acting upon the different specific gravities of water and benzine. In this single operation about 80 per cent. of oil is extracted. As soon as the condensing of the vapours begins, which is a certainty that the drying is complete, the liquid benzine-pipe, leading to the bottom of the extractor, is closed, and the solvent tank is connected with the *top* of the extractor, letting the solvent run *down* through the warm crushed seed. The oil left in the seed is rapidly and completely solved, and carried down towards the bottom of the extracting pot. Other makers of ancient plants now draw off the solution and distil the benzine until the extraction is finished. The great fault in this system is that during the greater portion of the process 90 to 98 per cent. of benzine has to be distilled in order to obtain a few per cent. of oil. Loss of benzine and steam is the natural consequence.

“Another feature of this new plant is that the solution is conducted from the first pot into the second, where the benzine is allowed to be thoroughly saturated before it is drawn into the still for distillation. This concentrating process is continued by coupling on the third and fourth pots. Meantime (for about three hours) fresh benzine having continuously been playing on the first pot, there is practically no oil left in the seed. In order to get the liquid benzine out of the seed, the steam coil is again heated and forces the liquid benzine to evaporate. Then live steam is introduced, which carries along the benzine vapour; and, as the seed is above 100 C., the steam passes through without condensing. This finishes the process. The manhole above the bottom plate is then opened and the perfectly dry, odourless meal is removed. The other pots are treated in the same way, and an ideal extraction is obtained.

“The extracting process lasts from 4 to 6 hours, according to the oily contents of the seed. The principal matter is the selection of the right quality of solvent, as many failures are traced to the purchase of cheap and unsuitable benzine. The advantages of extraction by solvents are said to be: (1) Unfailing yield of the whole of the oil contained in the seed, and independence of the vagaries of workmen; (2) Cheapness in working compared with the pressing system. Four hands suffice to work the largest plant. The loss of solvent should not exceed $\frac{1}{2}$ per cent. on the weight of the material treated. The cost per ton of seed treated is said to be about R3 against R13 by pressing. The meal and the oil are perfectly free from the smell of the solvent, and the oil is bright and clear. The meal is perfectly dry, and is saleable immediately after being bagged. The cost of an extraction plant is said to be about one-third of the price of the usual pressing plant.”

NEW FIBRE-EXTRACTING MACHINE.

The accompanying illustrations give a fair idea of a newly-invented decorticating machine, which is the outcome of the inventor's practical experience with fibre machinery in foreign countries. The manufacturers are Messrs. Marshall and Sons, Limited, England, and the agents in Australia, Messrs. Robison Bros. and Co., Limited, South Melbourne, Victoria. The main feature of the machine is an improvement on other methods of fibre-extraction by mechanical means. The fibre machines at present on the market are, almost without exception, constructed on the “scutching” principle. This liberates the fibre by a rapid succession of heavy blows, which deteriorates the fibre by weakening it, and, in addition, makes a large percentage of “shorts.” This serious defect has been overcome, it is claimed, by the inventor of the new machine, Mr. Andrews, by substituting for the beating action a gentle combing motion, which removes all useless vegetable matter from the fibres. The result is, a large output of clean straight fibre of better quality, and, consequently, of higher value than can be produced by scutching. No reversing of leaves or gear is needed, and the fibre is delivered at the end of

the machine thoroughly cleaned throughout its length. Many delicate fibres, hitherto unworkable by machinery, have been successfully dealt with by this simple invention. The only preliminary treatment required is to crush the stems or expel the bulk of moisture from the leaves. This can be done by rollers or any other flattening method. A water-spray is operated during the combing process.

The principal features of the machine are: Two drums revolving in opposite directions, each working one-half of the raw material fed into the receiver. These drums are fitted with bars, set over with a number of pins, graded from coarse to fine. These gradually break up the leaves or stems and comb the fibre to any degree of fineness required.

The pins clean themselves automatically at each revolution of the drums.

After crushing, the leaves are fed into the machine as shown at right angles to their length; they are brought into position for the action of the combing pins by the continuous motion of two chain-conveyors, which traverse the drums. The first conveyor holds one-half of the leaves or stems until the remaining half is completely combed; this cleaned half is then automatically grasped by the second conveyor and carried along the second drum. As regards output, plants of a fibrous nature differ so materially in structure, strength, and a quantity of fibre that it is impossible to put forward figures on this point which will be accurate for all varieties. But, from tests which have been made, it is estimated that with effective crushing and intelligent feeding the machine will treat from $2\frac{1}{2}$ to 5 tons of green material per day of 10 hours. That is to say, that given sisal leaves weighing 3 lb. each and yielding 1 oz. of fibre the output of fibre would be from $466\frac{1}{2}$ lb. to 933 lb. per day of 10 hours. The driving power needed is from 7 to 9 h.p.

We do not know the price of the machine. The Lehmann (Manchester) No. A machine costs £65 in Manchester, and will turn out 750 lb. of clean fibre per day of 10 hours.

DESTRUCTION OF PRICKLY PEAR.

What appears from authentic accounts to be a most effective instrument for the destruction of prickly pear has been brought under our notice by the inventor, Mr. C. L. Kirby, of Geera, near Barcardine. It is a brass cylinder, weighing from $4\frac{1}{2}$ to $6\frac{1}{2}$ lb., which holds from 400 to 600 doses of any good prickly pear poison. The lower end is furnished with a convex spear, flattened on one side. This spear is driven into the pear, a twist to the right enlarges the opening, and a piston or plunger, operated at the other end, drives a portion of the poison deep into the plant. The piston will eject a single drop gently, or drive a full dose with force. Mr. Kirby stated that he and his two brothers, each operating a machine, effectually inoculated all the pear on 5 acres in $1\frac{1}{2}$ hours. The machines are used in large numbers in New South Wales, and in a letter to Mr. Kirby from the New Zealand Loan and Agency Company it is stated that it does the work rapidly and surely. The price of the machine is, for the larger size, £3 15s., and for the smaller, £3 10s. Mr. Kirby is also the inventor and patentee of a rabbit destroyer, which is used largely in the South to destroy rabbits in their burrows by fumigation with carbon fumes. One gallon of carbon is sufficient to kill hundreds of rabbits, and 5 gallons, costing 25s., will serve for 8,000 charges in the machine.

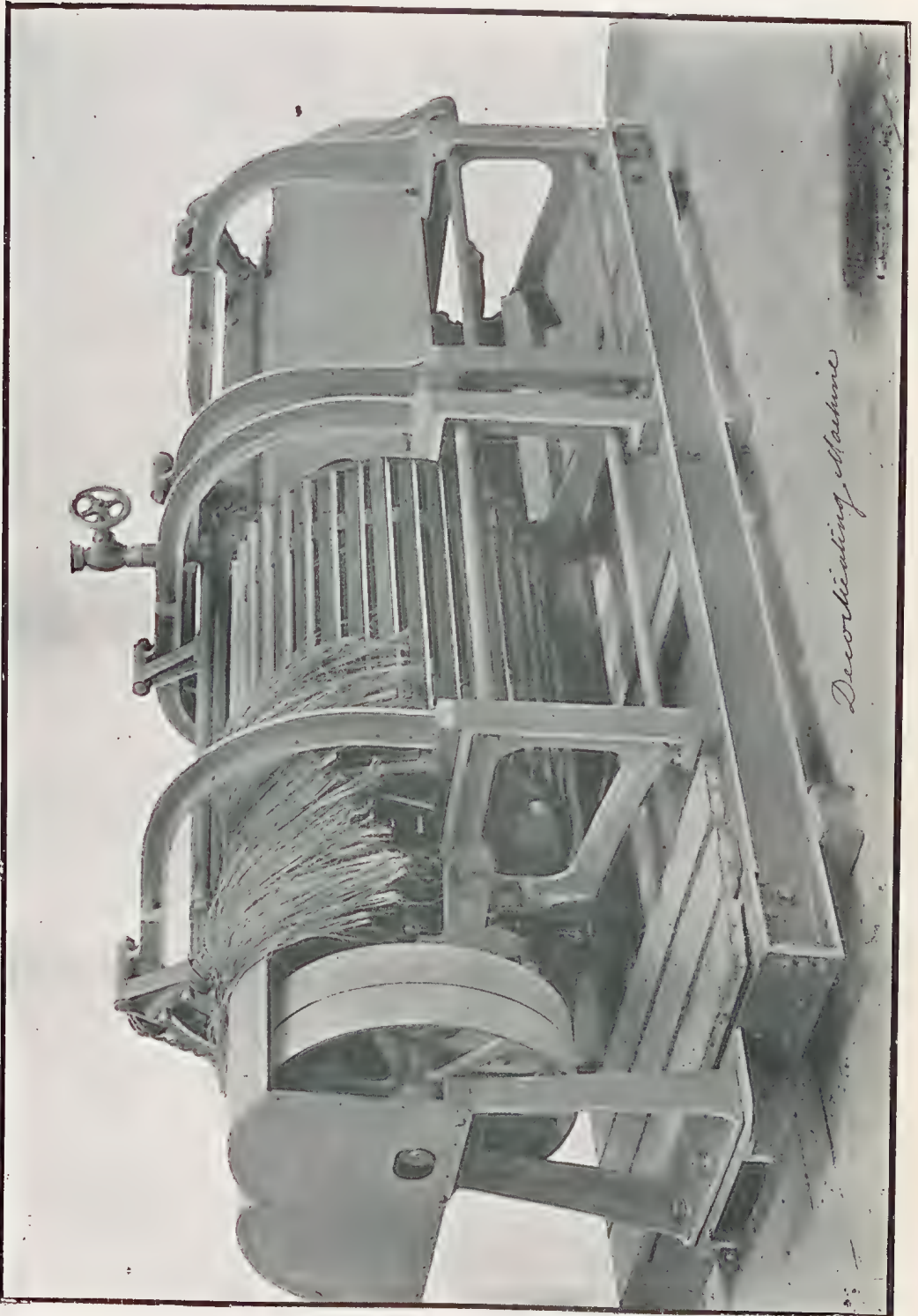

Decorticating Machine

THE "ANDREWS" DECORTICATING MACHINE—FRONT VIEW.

Plate XXXV.

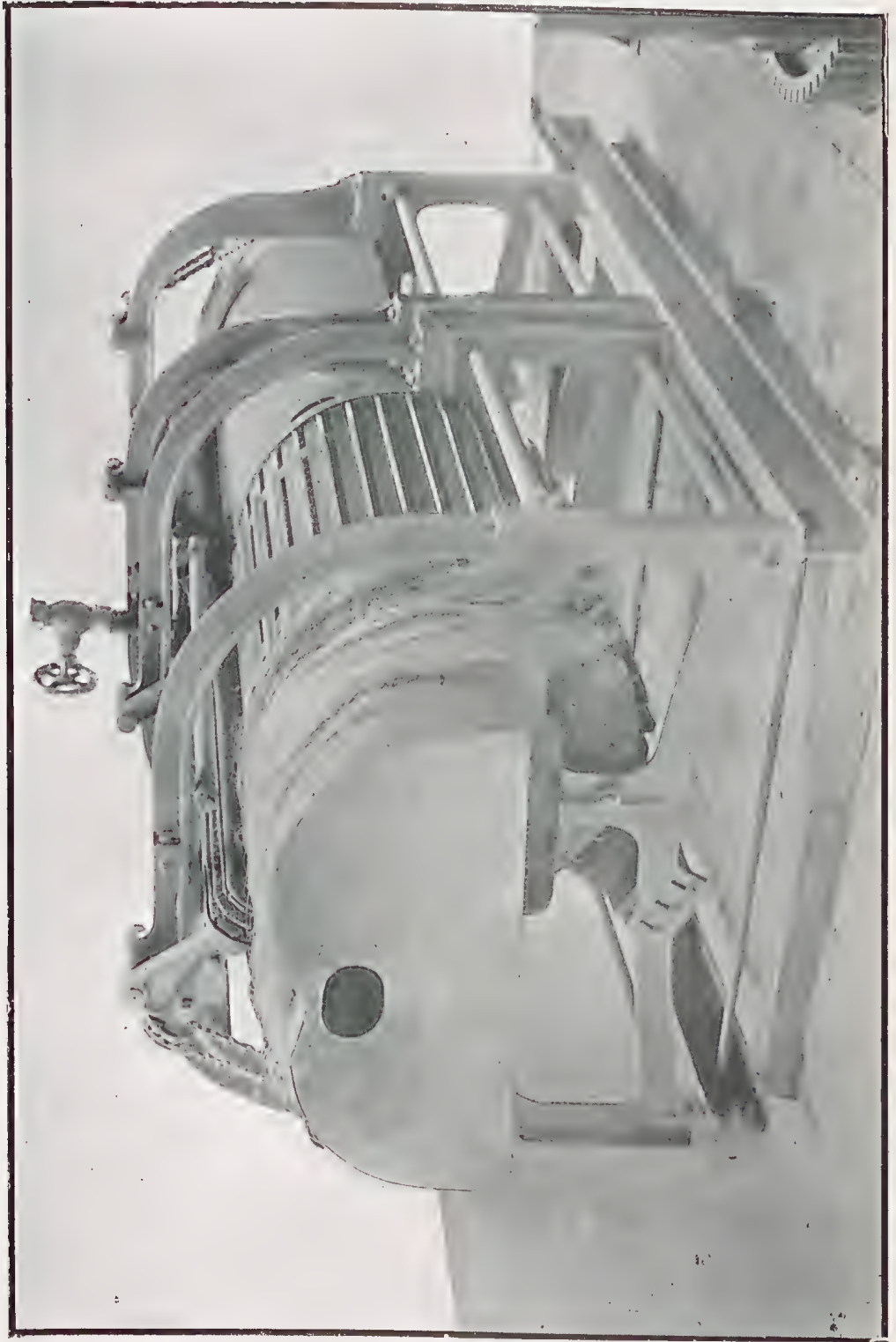

THE "ANDREWS" DECORTICATING MACHINE—BACK VIEW.



General Notes.

SPARROWS.

Mons. A. Dubois, in "Science et Nature," devotes several pages to the denunciation of the sparrow, nor does he exclude the supposed friend of the agriculturist, the hedge sparrow, which does not frequent cities or even country villages, from his anathema. Many people, he declares, who are otherwise sensible, persist in believing that sparrows (at least *Passer montanus*) are indispensable to agriculture. That was the opinion of most ornithologists 50 years ago, and thus these scientists have been the cause of the introduction of the domestic pest (*Passer domesticus*), otherwise the house sparrow, into the United States and many English colonies. But 20 years ago sufficed to show the Americans the mistake they had made, and now they are striving by all means in their power to get rid of these little robbers.

It is a mistake to think that insectivorous birds are always useful; certainly they do good service, but not so much as they are credited with. Insects, like birds, are divided into the useful, the indifferent, and the noxious classes, and the latter are the least numerous species. If a bird only lived on useful insects, still, although classed as insectivorous, it would become, from an agricultural point of view, a noxious bird. But it is quite evident that a bird is incapable of distinguishing between its victims,* and it takes all which suit its taste, as every bird has its preferences. The sparrow, for instance, will not touch certain destructive caterpillars which it does not like. The gooseberry caterpillar (*Abraxas grossulariata*) is rejected by the majority of birds, and he thinks the same objection on their part applies to the *Geocrisæ*, owing to the disgusting smell of those bugs. [Surely this proves that a bird is capable of selecting its victims.—Ed. "Q.A.J."] Consequently, it is principally amongst the useful and indifferent insects that birds seek their food. In fact, the examination of 128 stomachs of young sparrows containing insects has revealed the remains of 50 useful insects, 28 semi-useful (or indifferent), and 44 noxious insects; 3 stomachs contained remains of insects which were undistinguishable. These verifications were made by the Department of Agriculture at Washington.

In Belgium there are about 13,000 species of insects, and in this number there are only about 500 noxious, and of the latter only 118 are very destructive and about 600 useful (parasites or carnivorous), the rest are indifferent. Thus, of the 13,000 species of indigenous insects there are about 11,900 which are of no importance one way or the other to agriculture or sylviculture. What harm, then, do those insects effect which live, for example, on thistles, nettles, and on a host of useless wild plants? Rather do they do us a service in ridding the land of vegetation which uselessly exhausts the soil.

It results, from what has been said, that if there is reason for protecting the true insectivorous birds, there is none for tolerating the presence of sparrows whose ravages considerably exceed their services. M. Dubois then goes on to demonstrate this proposition. To begin with, it must not be forgotten that the relative abundance or rarity of destructive insects is intermittent, and that, for many reasons, the principal of which must be attributed to the Ichneumon flies, which deposit their eggs on the skin of caterpillars and larvae, which end by being devoured by their guests. One can realise the importance of these parasites, charged with the duty of preserving the equilibrium by confining a species which too rapidly multiplies to the just limits which Nature has assigned to them.

* We do not agree with M. Dubois in this latter statement, which he, indeed, confutes later on. The woodcock, for instance, feeds exclusively on an insect which gives to epicures a zest for the trail of the woodcock on toast.—Ed. "Q.A.J."

Blanchard states that of 200 caterpillars collected by him, only three produced butterflies; the other 197 had been devoured by the larvæ of the terrible Ichneumons. Without the assistance of these useful auxiliaries crops would be more frequently ravaged. The caterpillar of the grape vine in France disappeared through their agency. A pear-tree in M. Dubois' garden was covered with caterpillars which devoured all the foliage. Never did he see a sparrow touch a caterpillar, although there were a number of nests of young sparrows near it. It is certain that if these birds fed on them the pear-tree would soon have been clean. This proves that sparrows will not take the first caterpillar that comes to hand, although the latter may not be hairy. Furthermore, as will be shown, as soon as fruit trees are in flower the sparrows devour the most essential organs of the flowers.

The sparrow must not only be judged by its depredations, but also on the indirect evil it occasions by driving from its domains certain birds more insectivorous than itself. It cannot certainly be denied that, so long as a sparrow is in the nest, it feeds almost exclusively on insects and larvæ, and that at that period of its life it consumes considerable numbers of them. This has given rise to the belief that this bird is much more insectivorous than graminivorous, and that its ravages are largely compensated for by the service it renders in the destruction of insects. Naturalists long defended this theory, as did M. Dubois himself, until experience showed him his mistake.

In the firm belief that the house sparrow is a bird indispensable to agriculture, the English introduced it into some of their colonies, and the Americans did the same; but both now regret it. A practical people like the Americans would certainly never destroy sparrows which they had introduced at considerable cost if they had not sufficient proof that the birds caused great damage. The whole matter resolves itself into the question: Has the damage caused by insects increased or decreased in the United States since the introduction of the house sparrow?

After 20 years' experience the Americans have concluded:—(1) That the sparrow causes great damage; (2) that the ravages by insects have rather increased than diminished; (3) that many insectivorous birds, native to the country, have been driven out by the more vigorous sparrow, which has taken full possession of their previous haunts.

M. Dubois, after pointing out the dates on which sparrows were introduced into various States of America, gives a long list of investigations into the content of the stomachs of sparrows in Germany. In England, Colonel Russell put the following questions to the defenders of the sparrow:—Why are not fields situated at a distance from habitations, and where there are no sparrows, not devastated by noxious insects? And why do these latter not multiply beyond measure in the county of Essex, where the sparrows were completely exterminated years ago? The answer is simple. The sparrow has been replaced by other insectivorous birds, which its presence had formerly displaced.

Now, a word about the hedge sparrow (*Passus montanus*). This bird has not been introduced into the New World, but it is met with all over Europe and Asia, including the Indian Archipelago, and even as far north as the Polar Circle. It inhabits the woods and mountains, and loves trees, open fields, and isolated farms, but is rarely seen in towns, although it frequents towns in oriental countries, and in Java as well. It is quite probable that if, in the old country, it lives in the woods, the reason is to be found in its having been driven out by the more robust house sparrow. The hedge sparrows are very sociable, and in autumn move about in flocks of over a thousand, mixing with other birds. Suddenly they leave in a body for some other locality, and in Spring they pair and separate. They feed mainly on grain, and cause serious damage in wheat fields, whence it is impossible to drive them, and bird-scarers have no effect on them.

HOW TO TREAT A RUSTY TANK.

Portland cement and *boiled* linseed oil should be mixed together in such proportions as will produce a paint of the consistence of cream. All dirt should be washed off the tank, and the mixture applied with a large paint brush. After a day or two, a second coat should be applied. It will take a little time to harden, and is elastic, and will be found thoroughly effective. It is even better if applied both within and without.

CREATION OF A NEW STRAWBERRY.

The production of a white strawberry which bears all the year round, instead of at certain seasons only, is claimed, says "Australian Field," by Hugo H. Lilienthal, a Berkeley horticulturist. He is a German who has produced various creations of an unusual kind in the way of fruit and flowers. The white strawberry, his most recent creation, is the result of a long series of experiments with crossing different varieties under different conditions. Lilienthal claims to have produced two distinct varieties of berries, which will bear through the full year, making a Christmas berry easily obtainable. One of these is white, the other red, and both are said to be of excellent flavour.

Answers to Correspondents.

ACACIAS AND POINCIANAS.

"ACACIA," Queensland.—

Send specimens of both to the Colonial Botanist, Mr. F. M. Bailey. Acacias and poincianas belong to two different orders botanically.

SETARIA ITALICA.

J. PARKER, Boolburra.—

The specimen of grass forwarded for identification is *Setaria italica*, commonly known as panicum in Queensland. It is grown in most countries as a fodder and for hay-making.

RINGWORM ON HORSES.

J. H. RYAN, Cannon Valley, Proserpine.—

Ringworm usually results from an unhealthy condition of the skin, and is, in most cases, produced by neglect of grooming or by bad food, or by any sudden change of diet, even from bad food to good. If any positive cause, such as bad forage or neglect of grooming can be ascertained to have existed, measures must be taken to rectify it, otherwise local treatment will not be of much avail. As regards local treatment, scrape each spot well with a scapula—not roughly, but sufficiently to clear off the fungus, and also clean off the hair for half an inch round the spot. When the fungus has been removed, the spot will become red and moist, but not bleeding.

Wash well with warm water and soap, and then dry it; then pass very quickly over the spot with a stick of nitrate of silver, and also very lightly over the hair on the margin of the spot. It is not necessary to keep the horse off his work unless there are any spots under some part of the harness.

DITCH MILLET (*Paspalum scrobiculatum*).

C. H., Kin Kin, Cooran.—

The specimen forwarded is described by Mr. F. M. Bailey, Colonial Botanist, as *Paspalum scrobiculatum*, or Ditch Millet. It is a very coarse grass, often met with on wet land; when closely cut or fed down, freely eaten by stock, but if allowed to stand and become old, refused except by very hungry cattle. A grass of most tropical and sub-tropical countries.

TROPICAL CLOVER.

H. MATZAT, Mossman.—

Mr. Bailey believes that the so-called clover you describe as having been brought by you from Samoa belongs to some species of *Desmodium*. If not useful as a fodder plant, it would be likely to become a great pest to cultivators of the soil, for the clinging hairs of the pod articles would assist its seeds in being carried far and wide over the country.

ANALYSES OF SPEAR AND BLUE GRASS AND MOLASSES.

A. L. P., Charters Towers.—

Blue grass (*Andropogon sericeus*) is a good grass, but not so nutritious as couch grass, *Paspalum*, or Rhodes grass, being rather deficient in nitrogenous or flesh-forming bodies.

Spear grass: Several grasses are called spear grass. One of the varieties is being analysed now, but analysis will not be available for some time.

Molasses contain only carbohydrates or heat-producing nutrients (about 55 per cent.), and no nitrogenous nutrients.

Dried offal from meatworks' digesters varies in composition, but contains on an average about 6 per cent. of nitrogen, corresponding to about 37 per cent. of nitrogenous material, and about 10 to 15 per cent. of phosphoric acid, corresponding to about 20 to 30 per cent. of calcium phosphate (bones).

The Markets.

PRICES OF FRUIT—ROMA-STREET MARKETS.

| Article. | APRIL. | |
|---|---------|------------|
| | Prices. | |
| Apples (Hobart), per case ... | 3s. | to 7s. |
| Apples (Victorian), per case ... | 4s. | to 8s. |
| Apples (Local), per case ... | 3s. | to 4s. 6d. |
| Apples (Cooking), per case ... | 4s. 6d. | to 6s. |
| Bananas (Cavendish), per dozen ... | 1½d. | to 2¼d. |
| Bananas (sugar), per dozen ... | 1d. | to 1½d. |
| Custard Apples, per quarter-case ... | 3s. | to 5s. |
| Lemons (Italian), per case ... | 11s. | |
| Lemons (Sydney), per case ... | 3s. 6d. | to 7s. |
| Mandarians, per case ... | 5s. | to 7s. |
| Oranges, per case ... | 3s. | to 4s. 6d. |
| Papaw Apples, per quarter-case ... | ... | |
| Passion Fruit, per quarter-case ... | 3s. | to 4s. 6d. |
| Peaches, per quarter-case ... | ... | |
| Plums ... | ... | |
| Pears, per case ... | 8s. | to 10s. |
| Pineapples, rough, per dozen ... | 3s. 6d. | to 4s. 6d. |
| Pineapples smooth, per dozen ... | 1s. | to 5s. 6d. |
| Pineapples, Ripley Queen, per dozen ... | 6s. | |
| Tomatoes, per quarter-case ... | 1s. 6d. | to 2s. 3d. |

SOUTHERN FRUIT MARKET.

| | | |
|---|---------|------------|
| Apples (Hobart), per case ... | 5s. | to 6s. 6d. |
| Apples (Victorian), per case ... | 4s. | to 6s. |
| Apples (Local), per case ... | 5s. | to 9s. |
| Apples (cooking), per case ... | 3s. 6d. | to 5s. 6d. |
| Bananas (Queensland), per bunch ... | 1s. 6d. | to 3s. |
| Bananas (Queensland), per case ... | 8s. | to 9s. |
| Grapes (Queensland), Muscatels, per box ... | ... | |
| Lemons (Local), per gin case ... | 8s. | to 10s. |
| Lemons (Italian), per box ... | 12s. | to 14s. |
| Lemons (Italian), per half-case ... | 8s. | to 9s. |
| Mandarins (Local), per half-case ... | 3s. | to 4s. 6d. |
| Mandarins (medium), per half-case ... | 2s. 6d. | to 3s. |
| Mangoes, per case ... | ... | |
| Nectarines, per half-case ... | ... | |
| Oranges (Choice), per case ... | ... | |
| Passion Fruit (Choice), per half-case ... | 4s. | to 5s. |
| Peaches (Slipstones), per half-case ... | 3s. 6d. | to 4s. |
| Peaches (Clingstones), per half-case ... | 3s. | to 3s. 6d. |
| Peanuts, per lb. ... | 5½d. | |
| Pears (Choice), per gin case ... | 10s. | to 12s. |
| Pears (medium), per gin case ... | 6s. | to 7s. |
| Pears (China), per gin case ... | 1s. 6d. | to 2s. |
| Persimmons, per box ... | 1s. 6d. | to 3s. |
| Pineapples (Queensland), Ripley Queen, per case ... | 6s. | to 7s. |
| Pineapples (Queensland), choice, Queens, per case ... | 5s. | to 6s. |
| Pineapples (Queensland), choice common, per case ... | 4s. | to 6s. |
| Plums, per half-case ... | 1s. 6d. | to 2s. |
| Quinces, per gin case ... | 3s. 6d. | to 4s. |
| Rock melons, per case ... | 2s. | to 4s. |
| Strawberries (Local), per dozen punnets ... | 3s. | to 6s. |
| Tomatoes (Local), per half-case ... | 1s. | to 2s. |
| Water melons, per dozen ... | 2s. | to 6s. |

PRICES OF FARM PRODUCE IN THE BRISBANE MARKETS FOR
MARCH.

| Article. | | | | | | MARCH. | |
|------------------------|-----|-----|-----|-----|-------|----------------------|--|
| | | | | | | Prices. | |
| Bacon, Pineapple... | ... | ... | ... | ... | lb. | 7½d. to 9d. | |
| Barley, Malting ... | ... | ... | ... | ... | „ | 3s. 6d. to 3s. 9d. | |
| Bran ... | ... | ... | ... | ... | ton | £5 15s. | |
| Butter, Factory ... | ... | ... | ... | ... | lb. | 9½d. | |
| Chaff, Mixed ... | ... | ... | ... | ... | ton | £5 5s. | |
| Chaff, Oaten ... | ... | ... | ... | ... | „ | £4 15s. to £5 5s. | |
| Chaff, Lucerne ... | ... | ... | ... | ... | „ | £5 to £6 10s. | |
| Chaff, Wheaten ... | ... | ... | ... | ... | „ | £4 10s. to £5 10s. | |
| Cheese ... | ... | ... | ... | ... | lb. | 6½d. to 7d. | |
| Flour ... | ... | ... | ... | ... | ton | £11 to £11 10s. | |
| Hay, Oaten ... | ... | ... | ... | ... | „ | £5 to £5 10s. | |
| Hay, Lucerne ... | ... | ... | ... | ... | „ | £4 to £5 10s. | |
| Honey ... | ... | ... | ... | ... | lb. | 2d. to 2½d. | |
| Maize ... | ... | ... | ... | ... | bush. | 4s. 1d. to 4s. 2d. | |
| Oats ... | ... | ... | ... | ... | „ | 2s. 9d to 4s. | |
| Pollard ... | ... | ... | ... | ... | ton | 5s. 15s. | |
| Potatoes ... | ... | ... | ... | ... | „ | £6 5s. to £6 10s. | |
| Potatoes, Sweet ... | ... | ... | ... | ... | „ | ... | |
| Pumpkins ... | ... | ... | ... | ... | „ | ... | |
| Wheat, Milling ... | ... | ... | ... | ... | bush. | 4s. 3d. to 4s. 7d. | |
| Wheat, Chick ... | ... | ... | ... | ... | „ | 4s. 2d. to 4s. 4d. | |
| Onions ... | ... | ... | ... | ... | ton | £7 10s. to £8 5s. | |
| Hams ... | ... | ... | ... | ... | lb. | 11d. to 1s. 0½d. | |
| Eggs ... | ... | ... | ... | ... | doz. | 1s. 2½d. to 1s. 6½d. | |
| Fowls ... | ... | ... | ... | ... | pair | 2s. 6d. to 3s. | |
| Geese ... | ... | ... | ... | ... | „ | 5s. to 6s. | |
| Ducks, English ... | ... | ... | ... | ... | „ | 3s. to 3s. 4d. | |
| Ducks, Muscovy ... | ... | ... | ... | ... | „ | 3s. 4d. to 4s. 3d. | |
| Turkeys (Hens) ... | ... | ... | ... | ... | „ | 6s. | |
| Turkeys (Gobblers) ... | ... | ... | ... | ... | „ | 11s. | |

ENOGGERA SALEYARDS.

| Animal. | | | | | | MARCH. | |
|-----------------------|-----|-----|-----|-----|-----|-----------------------|--|
| | | | | | | Prices. | |
| Bullocks ... | ... | ... | ... | ... | ... | £8 15s. to | |
| „ (single) ... | ... | ... | ... | ... | ... | £10 2s. 6d. | |
| Cows ... | ... | ... | ... | ... | ... | £14 | |
| Merino Wethers ... | ... | ... | ... | ... | ... | £6 2s. 6d. to £8 10s. | |
| Crossbred Wethers ... | ... | ... | ... | ... | ... | 18s. | |
| Merino Ewes ... | ... | ... | ... | ... | ... | 18s. 6d. | |
| Crossbred Ewes ... | ... | ... | ... | ... | ... | 11s. 9d. | |
| Lambs ... | ... | ... | ... | ... | ... | 16s. 6d. | |
| Pigs (porkers) ... | ... | ... | ... | ... | ... | 15s. | |
| | | | | | | 36s. | |

Orchard Notes for June.

By ALBERT H. BENSON, M.R.A.C.

THE SOUTHERN COAST DISTRICTS.

The Notes of last month, referring to the care to be taken in the handling and marketing of all kinds of citrus fruits, apply with equal force during this and subsequent months till the end of the season.

Keep the orchard clean, and work the land to retain moisture. The handling of the citrus crop is the main work in many orchards, but where slowly acting manures are to be given their application should not be later than this month. They should be well mixed with the soil, so that when the Spring comes and the trees start a fresh growth a certain percentage of plant food will be available for the trees' use. Heavy pruning should be done now, whilst the trees are dormant. All large limbs should be cut off close to the main stem; the edges of the cuts should be carefully trimmed, and the whole wound, if of large size, covered with paint or grafting wax, so that it will not start to decay, but soon grow over. When the soil of the orchard is becoming deficient in organic matter, the growing of a winter green crop, such as mustard or rape, is well worth a trial. Clear the crop of fruit from the part of the orchard to be so treated. Plough the land well; work the soil down fine so as to get a good seed bed, and broadcast the mustard or rape. A manuring of 4 cwt. of meatworks manure and 1 cwt. of sulphate of potash per acre will produce a very heavy crop of green manure, and the plant food not required for the production of such crop will be still available for the trees' use in Spring.

Pineapples and bananas should all be cleaned up, and the land got into first-class order. Pineapples, where at all liable to frost, should be covered with grass or other suitable material. The growth of weeds between the rows of pines on land liable to frost is one of the best ways of encouraging frost, as frost will strike dirty, weedy ground, and injure the pines growing thereon severely, when it will do little, if any, damage where the land is kept perfectly clean—another advantage of cleanliness in cultivation.

TROPICAL COAST DISTRICT.

Keep the land well cultivated—plough when necessary to bury weed growth, and get the surface of the ground into a state of thorough tilth, as moisture must be retained in the soil by cultivation to mature the spring crop of fruit. This applies not only to oranges and other tree fruits, but to bananas and pines as well. A good start in spring means good bunches of bananas and early ripening pineapples. Heavy pruning can be done now in the case of all trees not carrying a heavy crop of fruit, but where citrus trees are heavily loaded the pruning should be put off till after the spring crop of fruit has been gathered. The spraying of the trunks and inside of the trees with the lime and sulphur wash can be carried out, and where Maori is making its appearance the sulphide of soda wash should be used as well.

SOUTHERN AND CENTRAL TABLELANDS.

The pruning of all kinds of deciduous fruit trees is the chief work of the month in the Stanthorpe district. Do not be frightened to prune severely, first, in the case of young trees, so as to get strong well-grown trees instead

of straggling top-heavy trees; and, second, in the case of trees that are going off in the size and quality of their fruit. Where peaches, apricots, plums, or nectarines are only making very little new growth, and that weak, so that the fruit produced thereon is small, it is advisable to head the tree hard back, so that it will throw out some vigorous branches in Spring that will form a new head for the tree. Apples, as well as plums and apricots, are sometimes inclined to overproduce fruit spurs, which become long and straggling, and bear a large quantity of small-size fruit. A vigorous shortening back and cutting out of such spurs will have a very beneficial effect in the quality and size of the fruit produced.

Gather and burn all prunings; and, where codlin moth is present in the orchard, examine the tree carefully when pruning it, so as to see if there are any cracks, crevices, or masses of loose bark in or under which the larvæ of the moth may be hibernating. All larvæ so found should be destroyed, and if the work is carried out systematically it will tend to materially decrease the crop of moths that will hatch out the following spring.

As soon as any part of the orchard is pruned, gather up the prunings, and work the land, as a thorough winter weathering of the soil is very beneficial in its effects; and, further, it will tend to destroy many insects that may be wintering in it. The planting of new orchards or of trees to replace any that may have died, or that have been proved to be unsuitable to the district, may be continued during the month, and right on till the end of winter.

Do not prune vines in the Stanthorpe district, as it is advisable to leave the pruning as late as possible, but vine pruning can be done at any time now in the Roma or Central districts. Tree pruning can be continued during the month, and the orchard should be kept well worked. Citrus fruits can be marketed. Lemons should be gathered and cured.

Farm and Garden Notes for June.

FIELD.—Winter begins on the 24th of this month, and frosts will already have been experienced in some of the more exposed districts of the Southern coast and on the Darling Downs. Hence, insect pests will, to a great extent, cease from troubling, and weeds will also be no serious drawback to cultivation. The month of June is considered by the most successful lucerne-growers to be the best time to lay down this crop, as any weeds which may spring up in the event of a dropping season will be so slow-growing that the young lucerne plants will not be choked by them.

The land should now be got ready for millets, sorghum, panicum, &c. Oats, barley, vetches, clover, tobacco, buckwheat, field carrots, and Swedes may now be sown. Some advocate the sowing of early maize and potatoes during this month, but, obviously, this can only apply to the more tropical parts of Queensland. The land may be got ready, but in the Southern districts and on the tableland neither maize nor potatoes should be planted before August, or at the earliest, in warm, early districts, at the end of July. There is always almost a certainty of frosts, more or less severe, during these months. Arrowroot will be nearly ready for digging, but we would not advise taking up the bulbs until the frosts of July have occurred. Take up sweet potatoes, yams, and ginger. Should there be a heavy crop, and consequently a glut in the market, sweet potatoes may be kept by storing them in a cool place in dry sand, taking care that they are thoroughly ripe before digging. The ripeness may be known by the milky juice of a broken tuber remaining white when dry. Should the juice turn dark, the potato is unripe, and will rot or dry up and shrivel in the sand pit. Before pitting, spread the tubers out in a dry barn or in the open, if the weather be fine. In pitting them or storing them in hills lay them on a thick layer of sand, then pour dry sand over them till all the crevices are filled and a layer of sand is formed above them. Then put down another layer of tubers, and repeat the process until the hill is of the requisite size. The sand excludes the air, and the potatoes will keep right through the winter. Late wheat may still be sown, but it is too late for a field crop of onions. In tropical Queensland the bulk of the coffee crop should be off by the end of July. Yams may be unearthed. Cuttings of cinnamon and kola nut tree may be made, the cuttings being planted under bell glasses. Collect divi-divi pods and tobacco leaves. English potatoes may be planted. The opium poppy will now be blooming and forming capsules. Gather tilseed (sesame), and plant out young tobacco plants if the weather be suitable. Sugar-cane cutting may be commenced. Keep the cultivator moving amongst the pineapples. Gather all ripe bananas. Fibre may be produced from the old stems. A hand machine for this purpose has just been introduced into Queensland from France, which will turn out 65 lb. of clean fibre in a day of 10 hours. The agent for the machine is Mr. A. Robinson, Civil Service Stores, Brisbane, and the price, we are informed, is £7 10s.

KITCHEN GARDEN.—Cabbage, cauliflower, and lettuce may be planted out as they become large enough. Plant asparagus and rhubarb in well-prepared beds in rows. In planting rhubarb it will probably be found more profitable to buy the crowns than to grow them from seed, and the same remark applies to asparagus.

Sow cabbage, red cabbage, peas, lettuce, broad beans, carrots, radish, turnip, beet, leeks, and herbs of various kinds, such as sage, thyme, mint, &c. Eschalots, if ready, may be transplanted, also horse-radish can be set out row.

The earlier sowings of all root crops should now be ready to thin out, if this has not been already attended to.

Keep down the weeds among the growing crops by a free use of the hoe and cultivator.

The weather is generally dry at this time of the year, so the more thorough the cultivation the better for the crops.

Land for early potatoes should now be got ready by well digging or ploughing.

Tomatoes intended to be planted out when the weather gets warmer may be sown towards the end of the month in a frame where the young plants will be protected from frost.

FLOWER GARDEN.—No time is now to be lost, for many kinds of plants need to be planted out early to have the opportunity of rooting and gathering strength in the cool moist spring time to prepare them for the trial of heat they must endure later on. Do not put your labour on poor soil. Raise only the best varieties of plants in the garden; it costs no more to raise good varieties than poor ones. Prune closely all the hybrid perpetual roses, and tie up, without pruning, to trellis or stakes, the climbing and tea-scented varieties, if not already done. These and other shrubs may still be planted. See where a new tree or shrub can be planted; get these in position; then they will give you abundance of spring bloom. Renovate and make lawns, and plant all kinds of edging. Finish all pruning. Divide the roots of chrysanthemums, perennial phlox, and all other hardy clumps; and cuttings of all the summer bedding plants may be propagated.

Sow first lot, in small quantities, of hardy and half-hardy annuals, biennials, and perennials, some of which are better raised in boxes and transplanted into the open ground, but many of this class can, however, be successfully raised in the open if the weather is favourable. Antirrhinum, carnation, picotees, dianthus, hollyhock, larkspur, pansy, petunia, *Phlox Drummondii*, stocks, wallflower, and zinnias, &c., may be sown either in boxes or open beds; mignonette is best sown where it is intended to remain.

To grow these plants successfully, it is only necessary to thoroughly dig the ground over to a depth of not less than 12 in., and incorporate with it a good dressing of well-decayed manure, which is most effectively done by a second digging; the surface should then be raked over smoothly, so as to remove all stones and clods, thus reducing it to a fine tilth. The seed can then be sown in lines or patches as desired, the greatest care being taken not to cover deeply; a covering of not more than three times the diameter of larger seeds, and a light sprinkling of fine soil over small seeds, being all that is necessary. A slight mulching of well-decayed manure and a watering with a fine-rosed can will complete the operation. If the weather prove favourable, the young seedlings will usually make their appearance in a week or ten days. thin out so as to leave each plant (if in the border) at least 4 to 6 in. apart.

Agriculture.

THE RISE IN WHEAT AND ITS JUSTIFICATION.

The steady rise of the price of wheat, which began as far back as last June (says the "Economist" of 13th March) is beginning to attract attention outside the immediate circle of the grain trade, for there is probably nothing so needful as a cheap and plentiful supply of wheat and other cereals. Whether to the world at large wheat is more important than rice may be doubtful; but there can be little doubt that for consumers in the United Kingdom it is the most important of all foods. It is estimated that every man, woman, and child in the United Kingdom consumes on an average 6 bushels per annum, or almost precisely 1 lb. per day, in the form of bread, biscuits, or pastry.

The present rise started about eight or nine months ago, when reports began to reach Western Europe that the growing crop in Russia and Roumania was beginning to give cause for anxiety. The market was at that time in a peculiarly susceptible state, as farmers' and merchants' reserves were unusually light, owing to the defective world's crop of 1907. Everywhere reserves had been freely reduced last summer in the belief that the harvest of 1908 would redress the deficiency of the preceding year, but fate ordained otherwise, for the world's wheat crop last year was very little bigger than that of 1907, and the result has been that merchants have had no favourable opportunity during the past twelve months of restoring their reserves, which consequently remain far below a normal level. For instance, the stock of foreign wheat and flour in the ports of the United Kingdom now amounts to only 1,200,000 quarters, or about 2½ weeks' supply at the present rate of consumption. It is years since the ports were so bare of wheat; indeed, one must go back to the Leiter corner year to match the present figures, and it is estimated that other stocks and stores are depleted, for millers, dealers, and bakers were all similarly influenced by the optimistic estimates of the growing wheat which prevailed last summer. The British—probably, too, the German and French—farmers have also contributed to the present situation, for they have run down their reserves, having marketed in the first six months of this season probably three-fourths of the crop harvested last August. Yet it is doubtful whether the whole of the rise in price since last June can be fairly attributed to the absence of sufficient reserves. The first thing to do is to ascertain definitely what the rise actually amounts to for the leading classes of wheat dealt with in England, together with similar data for other countries. The following are the prices on some of the principal world's markets now and eight months ago:—

| | 1 July, 1908. | March, 1909. | Difference. |
|---|---------------|--------------|--------------|
| | <i>s. d.</i> | <i>s. d.</i> | <i>s. d.</i> |
| British corn average per quarter | 30 11 | 34 10 | + 3 11 |
| Liverpool, Contract wheat per cental | 7 2 | 8 0½ | + 0 10½ |
| " No. 2 Red Winter " | 7 1½ | 8 5 | + 1 3½ |
| " Australian " | 7 10 | 8 2½ | + 0 4½ |
| " Argentine " | 7 3 | 8 1½ | + 0 10½ |
| " Baker's flour per sack | 25 6 | 29 6 | + 4 0 |
| Paris, wheat per quarter | 37 7 | 41 7 | + 4 0 |
| " flour per sack | 38 9 | 36 3 | + 2 6 |
| Berlin, wheat per quarter | 45 10 | 49 1 | + 3 3 |
| " rye " | 41 1 | 38 1 | - 3 0 |
| Budapest, wheat " | 39 4 | 49 6 | + 10 2 |
| Chicago, wheat per bushel | 85c. | 115c. | + 30c. |
| Winnipeg, wheat " | 101½c. | 109½c. | + 8c. |

From the foregoing it will be observed that the price of wheat is now roundly about 4s. per quarter (the equivalent of $\frac{1}{2}$ d. per quarter loaf) higher than it was eight months ago; in Chicago the rise amounts to 30 cents per bushel, or 10s. per quarter, a figure which also represents the rise in Budapest. In Berlin the price of wheat has risen to 49s. per 480 lb., but luckily for the German working classes there was a bumper rye crop, which made the rye duties largely inoperative, and the price of rye has fallen to 38s. per 480 lb. If the British working classes could be persuaded to eat rye bread, they could be cheaply fed, as the free-trade price of this cereal is extremely low, about two-thirds of the price of wheat.

One potent reason why wheat has risen in price and continues at the higher level is the growing belief that in Argentina the recent harvest has proved far less abundant than the preceding season's, and is much below the early pre-harvest forecasts. Last November it was confidently predicted that the crop would furnish an exportable surplus of at least 20,000,000 quarters, or 2,500,000 quarters more than the preceding season's. The Buenos Ayres agent of the Liverpool "Corn Trade News" was the first to sound a note of warning, cabling in October, and again in November, that frost in the northern region and drought in Southern Buenos Ayres had wrought serious injury to the young wheat plants. The message concluded with a forecast of 13,000,000 quarters as the probable exportable surplus, and, although this was looked upon at the time as somewhat sensational, events have satisfied the trade that it was a conservative estimate, and there are few, if any, authorities who believe now that the quantity will be reached, the general idea now being that the surplus will hardly exceed 11,000,000 quarters. The disappointment over the Argentine yield, it is believed, may suffice to account for the maintenance of the present level of prices, without making too much allowance for the effect of the manipulation at Chicago, where attempts are being made to corner the May and July deliveries—a belief which has eventuated in a certainty.

GRASSHOPPER DESTRUCTION IN SOUTH AFRICA.

The brown locust, which periodically invades the Transvaal in countless swarms, causes enormous losses to the farmers. In order to ascertain as fully as possible the amount of damage occasioned by these pests, the Agricultural Department of the Transvaal endeavoured to obtain an estimate of the value of the crops destroyed. These statistics were collected by the resident magistrates, but the amounts here given do not include the amount of the damage done to the veldt, so that the approximate damage must have amounted to nearly £1,000,000 sterling. The Transvaal "Agricultural Journal" for October, 1908, gives the amount of loss sustained in fifteen agricultural districts. The amounts range from £4,200 in Zoutpansberg to £155,840 in Pretoria and £219,421 in Potchefstroom, the total amounting to £641,860.

Such enormous losses demanded extraordinary efforts to destroy the devastating insects. The various colonies and Administrations in South Africa have consequently taken up the work in a spirit of whole-hearted co-operation, and, it would appear, with complete success. Even German South-west Africa and Portuguese East Africa, Swaziland, Rhodesia, Basuto-land, and Bechuanaland appear to have entered into the spirit of the wholesale extermination of one of the greatest insect pests known to civilisation with an energy which has had magnificent results, and which, it is hoped, will ultimately rid South Africa of this fearful scourge. The universal adoption of the arsenite of soda spray as a means of extermination seems to confirm the opinion that, for cheapness, simplicity of application, and effectiveness, it cannot be surpassed.

The success attained has been attended, naturally, with heavy expense, and the total cost of the brown locust campaign throughout South Africa may be estimated, roughly, at £32,000, exclusive of the cost of material. This appears an immense sum to spend on locust destruction; but, if accurate statistics could be obtained regarding the amount of money representing the crops saved, it would probably be found that the amount expended, including even the cost of material, would amount to less than 1 per cent. of the value of the crops saved. To give an idea of the cost of a single campaign against the locusts, the "Transvaal Agricultural Journal" says that the expenditure on the Cape Colony campaign amounted to between £8,000 and £10,000. According to the report, 14 tons of arsenite of soda were used, with 14 tons of crude sugar, 3 tons of treacle, and 1,500 spray pumps were in operation. From 10,000 to 20,000 swarms were reported to have been destroyed; and 2 horses, 2 sheep, 13 calves, and 41 cattle were supposed to have met their death by arsenical poisoning.

The Orange River Colony campaign cost £7,492 2s. 10d. The material used consisted of 43 tons of arsenite of soda, 98 tons of sugar, 40 tons of treacle, and 593 gallons of Fletcher's dip; and 5,000 spray pumps were in operation.

The Transvaal Colony spent £8,312 12s. 9d. on its campaign; the Rhodesian Colony, £4,630; and Basutoland, £1,850, exclusive of cost of material.

To give some idea of the enormous swarms of locusts to be dealt with, it is stated that one swarm alone was fully 15 miles across in front, and it took nearly three days to pass a certain point.

How the campaign is annually conducted is well told in the Journal from which we take the foregoing account of the work:—The swarm destroyed was a very large one, covering an area 500 yards long and 200 yards wide. They were in the hopping stage, and travelled closely packed together. They had already consumed every green thing on the adjoining farm. A single pound of arsenate of soda sufficed to destroy the whole swarm. The poison was mixed with 4 lb. of brown sugar, and dissolved with hot water in a boiler. Then cold water was added until a quantity of 12 gallons was made up. Six ordinary bundles (about 36 lb.) of green barley was soaked in it for about 15 or 20 minutes. The barley was not entirely immersed, but each bundle was loosened so that each stalk could fully absorb some of the liquid, of which about one-third was absorbed by the barley.

By waving flags the swarm was brought to a standstill close to the boundary of the farm. Then the barley was thinly scattered both in front of and among the grasshoppers, in the following manner:—Single stalks were scattered in thin rows over the swarm, each stalk in a row at a distance of about 4 ft. from the other, and each row of stalks 10 yards from the next row. In front the stalks were laid thicker. In this manner the barley was distributed over the major portion of the swarm. The rear of the swarm was not interfered with, as there was not sufficient barley. This was, however, of no consequence, as later on the grasshoppers closed up towards the front, and so were enabled to reach the poisoned bait.

As soon as the poison had spread amongst the swarm they came to a sudden halt. There was no need for further flag waving, as the grasshoppers no longer showed any desire to spread over the field. The creatures attacked the barley with avidity. Every stalk was covered with hundreds of grasshoppers, which were all poisoned. Before sunset numbers of the insects appeared sick, but so far none had died.

About 8 gallons of the poisoned fluid were left over. This was used in the following manner:—In the evening a number of grasshoppers, where they were the thickest, were killed by blows from bushes. The bushes were steeped in the poison, and thus the hoppers were plentifully sprinkled with it. On the

same evening the remains of the poisoned barley were carefully collected and burnt.

Next morning about one-third of the hoppers were dead, and the survivors were busily devouring them. No more poison was needed. Thenceforward the destruction proceeded automatically. In four days the whole swarm was annihilated. It is remarkable that birds which for two days had fed on the dead hoppers did not seem any the worse for it. The work was very easy, two white men and two natives having been employed only two hours over the business. From the moment the poison was strewed over the swarm, they made no attempt during the four days to move on.

THE GRASSHOPPER IN QUEENSLAND.

The grasshopper, although not so destructive or so numerous in this favoured State as in South Africa, is nevertheless sometimes very much in evidence. In 1904 we witnessed a campaign against them, when millions of "hoppers" visited the Isis district, at Childers. Mr. T. H. Wells, of Farnboro', made a very successful raid against them, when in the hopping stage, by driving them into shallow pits, about 25 ft. long. Long strips of calico were stretched on the rear and on both sides of the pit. Then a drive was started by a line of kanaka boys, who, armed with bushes, drove the hoppers before them till they fell into the pit, when they were speedily disposed of. Before this drive the grasshoppers so destroyed the sugar-cane leaves that nothing but the midrib was left (see illustration in this Journal, Vol. XV., p. 570). Many years ago we travelled from Georgetown to Cardwell with a detachment of native police, and at one point of our journey, near Parish's Springs, we encountered such a vast swarm of flying locusts that progress was impossible for half an hour at least, and the horses were as much alarmed by the noise made by the insects during flight as by the smart blows they received from them as they flew near the ground.

There is, however, one point in connection with the destruction of locusts by poison, and that is, the possible—indeed, highly probable—destruction of valuable insectivorous birds. The value of such birds to the farmer is incalculable, and if, during the nesting time, the parent birds are destroyed by feeding on the dead and dying locusts, what must become of the thousands of little nestlings who depend upon them for food? We have been told that in the Riverina district there is strong opposition to the poisoning of noxious animals, owing to the disastrous effect on bird life. This is a phase of the question which has only in one instance, above quoted, been touched upon in the articles we have quoted above, but it surely cannot have escaped the attention of the ornithologists and entomologists of the South African colonies, and it would be highly interesting and instructive to Australians to hear their opinion on this matter.*

CULTIVATION OF THE POTATO.

By THE EDITOR.

Next to the cereals, the potato is probably the most important food plant grown for man. It is a native of America, and was brought to England between the years 1580 and 1585 by Sir Walter Raleigh, from Virginia. It was received, however, with great disfavour; and the Church condemned it as an unholy article of diet, seeing the race and place from which it originated. It was not until the year 1805 that, by the exertions of Dr. Buchan, it became popular. In France it was quite neglected until a certain gardener,

* It will, however, be noted that in the Transvaal operations above described, the birds which fed on the dead hoppers did not suffer any inconvenience.

Plate XXXVI.



FIGHTING THE GRASSHOPPER IN THE ISIS DISTRICT.

who had grown some and found no sale for them, induced one of the kings of France to wear a potato blossom as a button-hole. This at once popularised the despised potato in that kingdom. Chemically, the potato consists of starch, gluten, and woody fibre, with, of course, water. On the authority of the late John Wilson, Professor of Agriculture, Edinburgh, an 8-ton crop of potatoes, taken from 1 acre of land, removes from the soil in which the tubers were grown—of the bases of alkaline earths, 90 lb. of potash, 8 lb. of soda, 5 lb. of lime, 7 lb. of magnesia; and of acids, 34 lb. of sulphuric acid, 20 lb. of phosphoric acid, 10 lb. of hydrochloric acid—in all, 170 lb. of inorganic matter. This was for tubers alone; and, if an equal quantity were allowed for the tops, the quantity taken from the soil would be about doubled.

MANURES.

It is, therefore, evident that, to grow potatoes to perfection, the foregoing constituent elements must be present in the soil. Professor Wilson found the best results to be obtained by preparing the soil early, and applying phosphatic and potash manures some time before planting, in the proportion of about 150 lb. to the acre. At the time of planting, nitrate of soda is sown in the drills at the rate of 1 cwt. per acre, and from $\frac{1}{2}$ to $\frac{3}{4}$ cwt. at earthing-up time.

On light, poor, sandy soils, nitrogenous manures in the form of sulphate of ammonia should be supplied at the rate of from 140 lb. to 170 lb. to the acre—one-half to be used at the time of planting, and the other half at the final earthing-up.

The matter of farmyard manures in growing potatoes is a somewhat vexed question. Undoubtedly farmyard manure is good, provided that it has been properly fermented and well decomposed; but there is nothing more fatal to good results with potatoes than putting fresh manure and potato setts together, for the young plant can never force its way through the fermenting mass of decay consequent upon slow decomposition.

Some interesting experiments, made in England by Mr. E. B. Hodley, Agricultural Superintendent to the Wilts County Council, threw considerable light on the matter of the use of artificial manures. The seasons were dry ones, and therefore more favourable to farmyard manure than to artificials, the yield from its use being considerably in excess of that obtained from the heaviest dressing ($12\frac{3}{4}$ cwt.) of mixed artificial manures. Where nitrogen, phosphoric acid, and potash have been applied in artificials, excellent crops have been obtained; but the heaviest crop of all was 14 tons per acre as the average of four years, grown where 8 tons of farmyard manure and 4 cwt. of sulphate of ammonia per acre were applied. The complete chemical manure was applied on different plots at the rate of 4 cwt., 8 cwt., and 12 cwt., respectively. Taking the averages for the four years, the 8-cwt. dressing proved the most economical, although the 12-cwt. dressing gave a somewhat heavier yield. When any one of the three constituents of the complete manure was omitted, there was a decrease of yield. Where the nitrate was omitted, the increase resulting from the application of kainit and superphosphate was not sufficient to pay for the cost; where superphosphate was omitted, the application of nitrate and kainit gave very little profit in excess of that obtained from the unmanured plots; and, although where kainit was omitted the yield most nearly approached that obtained from the completely manured plots, yet, even in this case, the profit was less than that obtained with a cheaper dressing of complete manure.

In conducting experiments of this nature, it should be remembered that artificial or farmyard manures will not invariably produce the same results on different soils. The rich, black soils of the Darling Downs, for instance, contain certain constituents which are wanting in lighter western or coast soils. In some there may be already a sufficiency of phosphoric acid; consequently, an application of superphosphate might prove injurious. Where

cultivation grounds are deficient, as most of them are, in phosphoric acid, it becomes necessary, in order to obtain a better crop, to secure support in the form of an easily soluble phosphoric acid. Bonedust is a phosphoric acid manure which gives this result; but superphosphates produce better and quicker results.

For potatoes, a fertiliser rich in potash is essential. For general purposes a good mixed fertiliser for this crop should consist of—Available phosphoric acid, 7 per cent.; potash, 11 per cent.; nitrogen, 3 per cent.; 700 lb. to the acre.

Sulphate of potash is mostly employed as a source of potash for potatoes. Muriate of potash is said to give even better results than the former.

Dried blood contains, on an average, 11 to 13 per cent. of nitrogen, but it is less soluble than sulphate of ammonia and nitrate of soda. Manures containing sulphate of ammonia should not be mixed with lime, nor applied to land which has been recently limed.

The value of kainit lies in its potash, of which it contains 12 per cent. It is the cheapest of the potash manures.

Following are the results of some experiments carried out by Mr. H. C. Quodling, Inspector of Agriculture, when manager of Westbrook State Farm. The manures used were—

- Superphosphate, at the rate of 4 cwt. per acre.
- Bonedust, at the rate of 4 cwt. per acre.
- Blood, at the rate of 4 cwt. per acre.
- Kainit, at the rate of 4 cwt. per acre.

One plot was unmanured, and planted with cut potatoes, and in the last plot, also unmanured, the potatoes were planted whole.

| Manure. | Rate per Acre. | Weight of Seed Planted | Cut or Uncut. | Yield per Plot. | Area of each Plot. |
|-----------------------|----------------|------------------------|---------------|-----------------|--------------------|
| | cwt. | lb. | | lb. | acre. |
| Superphosphate | 4 | 178 | Cut | 716 | 1/4 |
| Bonedust | 4 | 178 | " | 704 | 1/4 |
| Blood | 4 | 178 | " | 712 | 1/4 |
| Kainit | 4 | 178 | " | 722 | 1/4 |
| Unmanured | ... | 178 | " | 751 | 1/4 |
| Unmanured | ... | 178 | Uncut | 703 | 1/4 |

The best manure then, for potatoes, is a mixture of farmyard manure and some artificial. For instance, 16 tons of stable manure per acre will produce a larger crop than the most remunerative dressing of artificial manure; but, employ a mixture of 8 tons of stable manure and 3 cwt. of nitrate of soda, or an equivalent quantity of sulphate of ammonia, and a far greater yield will be obtained—in fact, such a dressing gives the greatest yield and the most remunerative results of any. If stable manure is unavailable, any artificial dressing for potatoes should contain nitrogen, phosphorus, and potash. Omit one of these (as has already been shown), and the result will be a poor crop. The omission of nitrogen will cause the greatest loss, and that of potash the least.

SOILS.

Of all crops grown, the potato is the one which shows the greatest content of potash in the mineral constituents withdrawn from the soil. Hence the well-known value of soil derived from granitic detritus for potato culture. In it, we have abundance of potassium silicate, derived from the decomposing felspar and slowly set free in other forms, for the uses of the plant. Where ground has been annually cropped with potatoes for many years without a rotation, it is mainly owing to the potash having been used up that the soil is not liberal in its return of tubers.

Some of our scrub soils yield a fairly good crop of tubers, but rarely over 4 tons to the acre, and these are usually somewhat watery and bad keepers, while there is frequently an abnormal growth of tops. The best potato lands in this State are the black and red soils of the Darling Downs, notably at Allora, and, nearer the coast, at Forest Hill, Laidley, and Gatton, where an 8-ton crop is no rarity. Generally, it may be said that potatoes may be grown on any soil, but that those grown on clay soils are waxy and of bad quality; light, granitic soils produce nice, mealy potatoes; and fertile loams yield the best tubers—best both in quality and quantity.

SEED POTATOES.

When we speak of seed potatoes, we mean potato tubers which are planted, whole or cut, to produce a crop. Potato seed is a very different thing. The potato is a *Solanum*, which produces flowers and seed vessels. The latter appear in the form of a small green apple or tomato, which contains a quantity of small seeds, and it is by sowing many thousands of these seeds that new varieties are produced, in very limited numbers compared with the enormous numbers of seeds sown, by scientific growers, who make the production of new kinds of potatoes a business, and a very profitable business it has often proved to these experimenters. Here, however, I am dealing only with the tubers or so-called seed potatoes.

There is a good deal to be studied in the selection, care, and treatment of seed potatoes, and many farmers take far too little care of them. When the summer crop is dug, the small potatoes are hauled to the barn, and either left in bags till the next planting season comes round, or else in a large uncovered heap on the floor. Then, when planting time has arrived, it is considered time enough to overhaul the heap, bags, or pit, and pick out the rotten ones. Too often the seed is found in a matted condition, owing to the potatoes not having been turned. This necessitates the whole mass being stirred up—a process which breaks off the majority of the shoots. All this means loss—a loss which can easily be avoided by being careful to turn the seed over occasionally, say about once a fortnight, or, at any event, a fortnight before planting, by which a gain in growth may be brought about. New shoots will then form, and they will be up as early as those which were planted immediately after the last turning. An important point is to plant no potatoes except those which have sprouted. This was conclusively proved to be correct at the Queensland Agricultural College, when one plot was planted with sprouted, and another with unsprouted seed. The former came up uniformly with scarcely any misses, whilst the latter plot showed an irregular growth and wide vacant spaces. In trials which were carried out for the Irish Department, at sixty-seven centres in sixteen counties, there was an average increase of 2 tons per acre from sprouting, and in the four preceding seasons the increase due to sprouting ranged from 1 ton to 2 tons 13 cwt. No stronger testimony could be desired.

Now, concerning the size of seed tubers. Opinions differ as to whether small or large seed gives the best results. A trial was made in England to settle the question. Three rows of equal length and with an equal number of sets were planted with Northern Star potatoes as follows:—

- Row No. 1: 38 sets, weighing 3 lb., produced 54 lb. of potatoes;
- Row No. 2: 38 sets, weighing 4 lb., produced 64 lb. of potatoes.
- Row No. 3: 38 sets, weighing 7 lb., produced 92 lb. of potatoes.

Assuming that the seed cost 1d. per lb. and the produce sold at 1d., we find that row 1 returned 4s. 3d.; row 2, 5s.; and row 3, 7s. 1d.—clearly a great gain in favour of the larger sets. All were planted on the same day, in equal ground, and all had the same amount of cultivation.

This leads to the subject of planting whole or cut tubers. Here again opinions differ. Some think it a waste to plant the sets whole, while others

think the best results are got with uncut seed. Now, at the Guelph Farm, Michigan, U.S.A., experiments were made which lasted for four years, to decide the matter. These experiments are reliable, and emphatically show the advantage of planting good setts.

The experiments were made to test the effect of the number of eyes in the setts. The difference in the yield between those with one eye and those with five was found to be very considerable, amounting to about 28 bushels, the results being as follow:—

From 1 eye, 136'41 bushels per acre.
 From 2 eyes, 144'70 bushels per acre.
 From 3 eyes, 153'13 bushels per acre.
 From 4 eyes, 162'82 bushels per acre.
 From 5 eyes, 164'37 bushels per acre.

Up to four eyes in each sett, the increase in the field is, roughly, 9 bushels for each additional eye, so that, up to that extent, the increase in eyes would be well repaid in the field.

Against this experience, I place that of a Queensland potato-grower, Mr. James Pink, of Wellington Point. He says:—It has been the practice to select for propagation the refuse of the potato heap; small, ugly, ill-shaped tubers have been considered good enough for seed, and where the result has not come up to expectations, the cry is raised that the potato is degenerating. In carrying out this practice for years, was it possible to arrive at any other result? But the very art of gardening is to lift Nature above her normal state, by raising new and improved varieties of seed, and by selection.

The method of selection is peculiarly adapted to the principle of growing from single eyes. If we take an average good-shaped potato, weighing from 6 to 10 oz., we shall find that it has from 12 to 18 eyes, which, if cut into single eyes, would give as many setts, which would naturally produce a more even sample than the same number of whole tubers of different sizes. The principle of growing from single eyes has two great advantages—namely, economy of seed, and, upon suitable, well-tilled land, a larger crop of marketable potatoes.

When whole tubers are planted, two or three eyes start into growth first; these keep the lead during the entire growing season, and from their stolons the largest potatoes are produced. The weaker eyes start later into growth, and produce only small tubers of little value; but, when single eyes are planted, the whole strength of the sett is devoted to one growth; all the young tubers are formed nearly at the same time, and the plant, having no other calls on it for nutriment, these continue to grow and form large tubers. The whole tuber produces the largest number of potatoes, but the single eye will produce the most uniform sample and the heaviest crop per acre.

With a view to ascertain the relative productiveness of tubers and setts, a series of experiments was carried out in the gardens of the London Horticultural Society. A piece of ground was divided into 4-ft. squares, and in the centre of each square was planted either a whole tuber, or a single eye, or a sett containing three eyes on the whole surface of the tuber pared off so as to leave the eyes safe, but removing the centre—a practice not uncommon in Scotland. These were, in fact, potato peelings. If we consider the results of the whole sixteen experiments as being but one experiment, we shall find their proportions expressed by the following figures:—

| | | | | | | |
|-------------|-----|-----|-----|-----|---------------|----------|
| Whole tuber | ... | ... | ... | ... | 333'38, or 2 | } nearly |
| Single eyes | ... | ... | ... | ... | 717'87, or 11 | |
| Three eyes | ... | ... | ... | ... | 613'94, or 6 | |
| Parings | ... | ... | ... | ... | 504'69, or 4 | |

In adopting the principle of the single-eye culture, it is requisite that the eye should be taken from large or averaged sized potatoes, for the smaller the potato the weaker its producing powers. The crown eye always grows

the strongest, and produces the largest potatoes. The eyes taken from the middle of the potato produce the best-shaped and most uniform tubers.

There are several ways of cutting the potato into single eyes. The principal thing to aim at is, to obtain a fair share of flesh of the tuber to each eye, with the least amount of cut surface. Take any potato and hold it before you with the stem end down. You will notice that the eyes are arranged around the tuber in regular ascending rotation from the bottom to the top, similar to the thread of a corkscrew. Now, take a sharp thin-bladed knife and remove the first eye by placing the knife equally distant between it and the eye next in rotation above it, sloping it to the indenture left by the stem, removing the flesh with it.

When the first eye is removed, turn the potato in your hand till the next eye appears; remove this in the same manner, and keep on turning the potato, removing each eye as it appears. These setts should be planted as soon as cut, and a little hot lime thrown over them will absorb the moisture, prevent premature decay, and also the attacks of insects. The above method could, however, scarcely be adopted by a farmer who plants large areas of potatoes. As an experiment, it is, of course, very interesting and instructive, and useful as being a simple means of increasing valuable new varieties of potatoes.

Some farmers utterly condemn the time-honoured practice of cutting up the potato into setts. One man says:—In all the trials which have been recorded of the potato crops produced from cut and uncut seed, I have never met with an instance of the cut tubers yielding the most or best. This fact must surely be generally known, and it is most surprising that it is not acted on. The process of cutting may increase the setts by about 30 per cent., but, if the time taken in cutting them, and the decreased yield be taken into consideration, no advantage whatever is secured, but the reverse. A man is far better off with a piece of land planted with 25 or even 30 cwt. of whole tubers than if it were planted with 1 ton cut up to cover the same space. If cutting the potato is done to save seed, that is a very poor reason.

In dealing with the cutting of potatoes, the large tubers are mostly cut into three pieces, the medium ones into two, and the small ones are let go whole. Plant the best and largest cut sett side by side with a whole tuber; it will invariably be found that the whole tuber produces the greatest number of potatoes, and certainly the largest ones. The difference in favour of the whole sett, I have frequently found to be 2 lb. to one plant, and imagine what this means in the case of thousands or tens of thousands of plants. The scarcer and more expensive a variety is, the more it is cut; and, consequently, the worse for the crop, and productive of certain degeneration. It appears to the writer, from his own practical experience, that, if potatoes are cut into setts with at least three eyes, the result is equally as good as when the whole tubers are planted, and that in the latter case there will be a larger proportion of small potatoes.

SPROUTING SEED POTATOES BEFORE PLANTING.

This is more often practised by cultivators of gardens than on the farm, but it has some decided advantages which all potato-growers may benefit by.

Seed potatoes are often badly prepared for planting, and still more often are not prepared at all. As a rule, they are kept in heaps in the barn or in bags till they are wanted in February or in August, or in a damp shed, where it is usually found that the growths have made considerable progress. The sprouts may be 2, 3, or 4 in. in length. They grow over and amongst the tubers like a network, and the greater part of them are broken off in moving the tubers, or before they can be separated. Many have little regret in doing this. They think it is necessary, and it is; but it is also exceedingly harmful, and this ought to be remembered, as deteriorated seed is always more or less unproductive. Fancy what the result would be were we to allow our corn to

sprout unduly before sowing! The excuse is that potatoes will resprout, and they will; but never so robustly as in the first instance. These long growths take a great deal out of the tuber which ought to be kept in reserve to facilitate the ordinary growth in the soil, and superfluous growth should be wholly prevented. This is easily accomplished if given timely attention, and I would urge growers that they look to their seed tubers at once.

The first treatment should consist of preventing the growths from becoming long or of a pale colour, which occurs when they are kept in the dark. Begin keeping them in the right way by turning the tubers over and removing any diseased one meets with. Do not put them in a heap again, but lay them out in a single layer on the barn floor or some other building where they will be fully exposed to the light and receive a good deal of air. This will not only check the production of long, weakly shoots, but it will green and harden the tubers, and this is a great benefit to them, as a greened tuber is much more hardy to come in contact with the soil than one that has been kept from light and air for six months or more. The growths, which will be slowly produced when laid out in a single layer and in light and air, will be short and robust and altogether different and superior to the shoots drawn up in the heap.

THE LEAST EXPENSIVE WAY.

This laying out is one way of sprouting potatoes which should be followed by every farmer who attempts potato culture. It is the least expensive way of treating them, and will always pay handsomely, as the first growth and subsequent results from prepared tubers are infinitely better than when they are taken straight from the heap and planted, which very many are, unfortunately. But there is another way of sprouting which is still better. This is to get a number of wood trays from 2 in. to 3 in. deep, and of any width and length; from 3 ft. to 4 ft. long, and 2 ft. to 3 ft. wide, are handy sizes. A little fine soil is put in the bottom, and the tubers are stood up on end as close as they can be packed in the trays. The ends with the eyes or buds on them are kept up, and the trays are placed in light, airy sheds, or such like places. Forcing them into growth is not advisable, the object being to get hardy little shoots on the tubers, which will not be checked when they come in contact with the soil in planting. The growths should not be more than 1 in. long when planted, and $\frac{1}{2}$ -in. is quite as useful a length. If trays cannot be provided for all of them, there is no reason why the whole should not be laid out in sheds, or the early sorts may be sprouted in trays first, planted, and the trays again filled with late kinds. The right time to put them in trays is before growth begins, and many of the early ones will require attention at at once. Sometimes there are blind tubers. When these are planted there is a blank, but in sprouting none but growing tubers should be planted. If it is seen that the growths are likely to exceed 1 in. in length before they can be planted, check them by admitting more air, but in doing this take care that a cold cutting wind does not reach them, and always be sure that they are protected from frost if that is occurring, as it still may. When the tubers are planted quite dormant it is often a long time before growth shows above ground. It might often be earlier without much chance of being injured by frost. All, too, desire their crops as early as possible if grown to meet early markets, and there is no better way of helping them on than the process of sprouting before planting, and having both tuber and growths in a sturdy, hardy condition when put in the soil. I have found this bring the crops in a fortnight or three weeks sooner at digging time than dealing with unsprouted tubers or those sprouted in the heaps, and the yield is also better from sprouted than unsprouted sets. Do not run away with the idea that there is a good deal of fiddling labour about it, and is not worth the bother, but look on it as a very important aid to successful culture and extra remunerative returns, and you will not be disappointed.

There can be no doubt that seed potatoes are weakened by the rubbing off of the shoots when they have sprouted badly, but that a good crop may be obtained from a second sprouting has often been proved. Potatoes have even been planted when every vestige of a sprout was rubbed off and not an unsprouted eye appeared, yet they sent up vigorous shoots.

FLOWERING AND SEEDING.

Under favourable conditions the potato plant flowers freely, and produces a green berry which contains the true seed of the plant. It is from these seeds that the different new kinds of potatoes are produced. I need not here go into the matter of the production of seedling potatoes, as what is intended here is merely instruction to young farmers who have had little or no experience previously in the art of successful potato-growing. The work of raising new varieties is expensive and tedious, and is only undertaken by certain growers (as I shall presently show when I come to the cross-fertilising of potatoes), who practically devote their lives to the business, sowing hundreds of thousands of seeds, to find sometimes only one new plant worth cultivating.

The potato plant does not produce seed so freely in this State as in colder climates, and it is, perhaps, as well that it does not flower heavily, since experiments on

THE EFFECT OF FLOWERING OF POTATOES,

made by a German scientist, some years ago, to ascertain whether blossoming was detrimental to the development of potato tubers, showed that the effort of the plant to provide for its reproduction by means of seeds seemed to result in a corresponding weakness in its root growth and in the size and numbers of the tubers. The experiments were carried out on a number of plots on similar soil, every condition being exactly the same. On one plot the plants were allowed to bloom as much as they liked, but the blooms of the plants in the other plots were cut off at different times. The crop that had not been topped at all was the worst yield, and the best crop was the one that had been prevented from blooming by being topped at frequent intervals. Those that were topped at the latest stage of the plants' growth were not so satisfactory as in the case of the crop frequently topped off.

[TO BE CONTINUED.]

CULTIVATION OF THE PEANUT.

Many persons on the lookout for some new payable crop in this State are turning their attention to the peanut as a source of profit, and we frequently receive inquiries concerning this product. Certainly, if such magnificent peanuts can be grown on a large scale as those grown by Mr. H. A. Tardent, at Wynnum, we should say it is a decidedly paying crop. Readers of the Journal will find several articles in past numbers showing that the cultivation of the peanut is profitable if only with a view to pig-keeping and oil-production. Bearing out what we have previously published on the subject, we find the following very interesting and instructive illustrated article on the "Origin and Domestication of the Peanut or Groundnut (*Arachis hypogaea*) in the United States," by S. A. Andrews, published in "Tropical Life":—

The origin of the peanut is the subject of much controversy, though it is considered by many that it is probably a native of Brazil. Whether this statement be true or not, it is certain that it was cultivated extensively in foreign countries before its merits were recognised in the land of its origin. The merits of this now important crop were recognised by slave-dealers, who loaded their vessels with it as food for their passengers. It was not extensively cultivated in the United States before the war between the States. The

scarcity of rations during the latter part of that historic struggle fixed the highly nutritious qualities of this peer among nuts on the attention of the individual members of the various armies then in the field, and immediately after the war much attention was given to its cultivation, especially in the South. At the present time, 7,000,000 bushels of nuts are produced annually, with a commercial value of at least 15,000,000 dollars, and it is safe to say that those grown exclusively as food for hogs, and which are not gleaned at the time of harvest, would add another 3,000,000 dollars to the value of this crop. At the present time a large proportion of the nuts are eaten, not as a regular part of the daily ration, but at odd times by all classes of our citizens.

The peanut is admirably adapted for the production of oil, and might be used advantageously for various other commercial purposes, but the demand for it as human food has been such in the past as to effectively prevent this. Since there is almost an unlimited area of country admirably adapted to its growth, not only in the United States, but in foreign lands as well, and since its cultivation is not difficult, there is no reason why it should not be grown extensively enough to meet all demands. The highly nutritious value of the peanut, and its favour among all people who are familiar with it, lend colour to the belief that its cultivation under the best modern practice will long remain a profitable business. This should stimulate and encourage many farmers, who are favourably situated, to devote a portion of their land to this important crop. Moreover, the peanut has some special advantages which make its utilisation as a rotation crop peculiarly desirable. It belongs to the family of legumes, and has, therefore, the power of gathering atmospheric nitrogen from the air in very considerable quantities. It produces also a rich and nutritious hay valuable for the maintenance of live stock. Since it is adapted for growth on rather thin and sandy soils as a rule deficient in vegetable matter, its power of largely obtaining its own nitrogen from the inexhaustible stores of the air is a most desirable attribute.

COMPOSITION.

The richness of the peanut as a food is better appreciated when it is stated that the kernels contain about 29 per cent. of protein, 49 per cent. of fat, and only 14 per cent. of carbohydrates. Peanut vines with the leaves contain between 11 and 12 per cent. of protein, 5 to 6 per cent. of fat, and 22 to 32 per cent. of carbohydrates. They are thus more nutritious than timothy hay, and should rank with that made from red clover. Peanut meal, which is the residue after the oil has been extracted, is a foodstuff of high value, and is appreciated and extensively used in foreign countries. It contains something like 52 per cent. of protein, 8 per cent. of fat, and about 27 per cent. of carbohydrates, and, therefore, ranks above cotton-seed meal, which is one of the most richly concentrated meals found on the market to-day. Like other legumes, the peanut contains considerable amounts of nitrogen, phosphoric acid, and potash, the latter two, of necessity, having to be largely supplied to the soil in a commercial form. But, on the whole, the peanut, as seen from the foregoing statements, is one of the most desirable and satisfactory crops which can be grown.

SOIL AND CLIMATE.

The peanut prefers a rather sandy, loamy soil, which should contain enough vegetable matter to make it light and porous, and also to prevent its becoming too dry. Since the trade demands a light-coloured shell, nuts of equal flavour and quality grown on other soils do not find a ready sale; and it may be proper to state at this time that the peanut can be grown on a very wide range of soils, provided they contain a sufficient amount of lime. This information should encourage many, who only wish to grow limited areas, either for grazing down by hogs or for home use, to experiment with

this important crop. There is an abundance of good peanut soil throughout the Atlantic seaboard. This area extends from New Jersey to Florida, and there is also much land on which this crop can be cultivated profitably in the Mississippi Valley. Only a small proportion of the available land is now being tilled.

The peanut will thrive under a great variety of climatic conditions provided there is a season of at least five months free from frosts. It has been thought by many that the peanut only grows well in a warm climate, but this is an error, since the nuts develop chiefly during the cool weather in the late summer and early autumn. The weather conditions most favourable to maximum production are an early spring, warm, even summer temperatures, with a well-distributed rainfall, and a comparatively dry autumn. Of course, climate has an influence on the character and composition of the nuts, since it has been demonstrated that in tropical countries a larger per cent. of oil is obtained. As to any other influences which climate may exert, but little is known, and the subject has not been as extensively investigated as the importance of this crop would seem to justify.

FERTILISERS.

Since the peanut is adapted for growth on a soil which is not naturally rich in any of the essential elements of plant food, the proper fertilisation of the crop becomes a matter of the utmost importance. It was found at the Tennessee Experiment Station that 60 bushels of peanuts with a ton of hay would remove from the soil about 85 lb. of nitrogen, 15 lb. of phosphoric acid, 32 lb. of potash, and 47 lb. of lime. Of this amount, about 41 lb. of nitrogen, 6 lb. of phosphoric acid, 20 lb. of potash, and 42 lb. of lime were found in the hay, and since the vines would either be left on the ground or fed to stock, and the resulting manure applied to the land, the peanut is seen to be a comparatively easy crop on the land so far as soil exhaustion is concerned. Besides, as has already been pointed out, it gathers a large percentage of its nitrogen from the air. Since it has been amply demonstrated that the yield of the crop may be greatly increased by judicious fertilisation, and since 100 bushels should be a fair average crop rather than the low yields now obtained, the importance of using sufficient amounts of all the essential elements to increase crop production and counteract the call made on the soil by the plant during the various stages of its growth becomes apparent.

The needs of a crop of peanuts may be appropriately supplied by using 1,200 lb. of high-grade acid phosphate, 400 lb. of dried fish, and 400 lb. of muriate of potash. This would give a mixture containing 1.6 per cent. of nitrogen, 10.2 per cent. of phosphoric acid, and 10 per cent. of potash. It may be stated that this ration has been found one of the most satisfactory to use on this crop. Another mixture which has been tried quite extensively is 1,300 lb. of acid phosphate, 300 lb. of dried blood, and 400 lb. of muriate of potash. This mixture would contain about 2 per cent. of nitrogen, 10.4 per cent. of phosphoric acid, and 10 per cent. of potash.

These mixtures should be used at the rate of 300 to 500 lb. per acre. Cotton-seed meal may be used to supply the nitrogen, if desirable, and kainit the potash, though, owing to lower percentages of available plant food contained in these two substances, larger amounts per acre would have to be supplied.

Many planters will find it advantageous to apply some farmyard manure to their peanut lands, since a small amount of vegetable matter mitigates the harmful influences which sometimes follow drought periods, and increases the vigour of the plant without injury to the quality or quantity of the nuts. Of course, the excessive use of vegetable matter might prove injurious, but this will seldom, if ever, happen until the entire system of rotation now in vogue

in the peanut belt changes radically. In fact, few peanut planters pay any attention whatever to the rotation of their lands, and grow the crop on the same area year after year. As a result, the nuts become small and inferior, and the vines tend to lose their leaves before maturity. A good physical condition of the soil is essential for this crop.

The importance of applying lime must also be emphasised in this connection, as there is comparatively little of the land devoted to peanuts which naturally contains enough of this important element. Lime may be applied in various forms.

Oyster shells are accessible to farmers living near the coast, and answer very well, though caustic lime is one of the best and cheapest forms in which to supply this element. Marl may be used in sections where there is an abundance of it, and it can be secured at a low enough cost. At least 30 bushels of lime may be applied per acre, and 100 to 150 bushels of marl. As a rule, lighter applications of lime made more frequently will prove the most profitable, and there is less danger of burning up the already deficient supply of humus when lighter applications are made.

A review of the fertiliser proposition, therefore, makes it clear that potash and phosphoric acid are the two most essential elements to be applied to this crop in a commercial form. That liberal applications also of these constituents prove profitable has now been fully demonstrated by scientific experiments and practical operations as well.

CULTIVATION.

The cultivation of the peanut is a comparatively simple matter. The seed bed should be finely pulverised to a depth of at least 5 in. Rake up the land in the spring as soon as it is in proper physical condition to work, and then harrow and roll, or use a smoothing-board, so as to obtain a level surface. Keep the land free from weeds until planting time by occasional stirring. This will tend to increase the supply of moisture in the soil, liberate plant food, and ensure a vigorous growth of the crop as soon as germination takes place.

The importance of selecting seed with care cannot be emphasised too strongly. The wonderful results obtained in the improvement of corn and various other crops indicate how much may yet be accomplished if the practice of seed selection is extended to the peanut. The seed should be selected from prolific plants, and should be carefully housed to prevent its exposure to unfavourable weather conditions. Only well-developed and perfectly mature seed should be planted, and it is very important that the seed be selected before the plants have been injured by frost. They should be allowed to thoroughly cure in the open air, and should then be stored in sacks in a dry, airy loft where they will neither heat nor collect moisture. About 2 bushels of seed in the pot should be allowed for each acre of land. The time of planting depends largely upon weather conditions. Most of the crop is planted from 1st April to June (in America), but planting may be done any time after danger of killing by frost is past. The seed is usually sown in drills, especially on land that has been well handled the previous year, and is comparatively free from weeds. The rows, as a rule, are 3 ft. to 3½ ft. apart, and the kernels are placed from 15 in. to 18 in. in the drill, depending on the fertility of the land. Planting is now generally done with an implement somewhat on the order of a cotton-planter. In fact, machinery is fast superseding hand labour in the cultivation of the crop, which is an advantage in many respects, since the work can be done more perfectly, quickly, and economically by machinery.

The peanut crop is sensitive to the interference of weeds, and the land should therefore be kept scrupulously clean. It is important that the work be done early in the season, since the runners must not be disturbed after



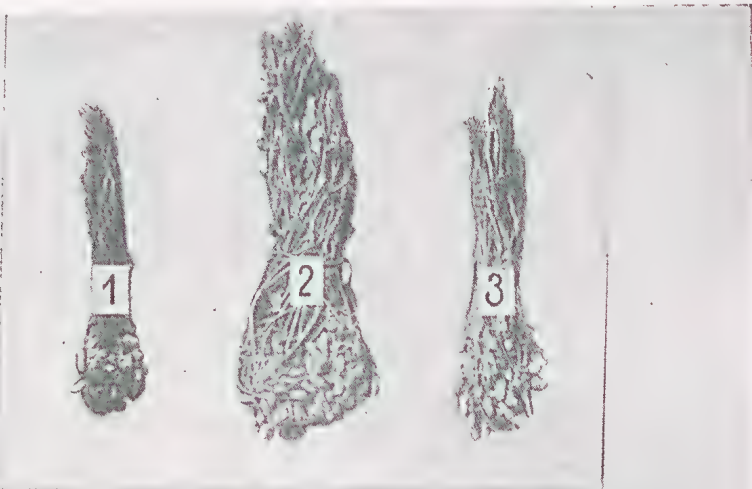

1. EXPERIMENT BY DR. GRIZZARD WITH POTASH, SUPERPHOSPHATE, AND DRIED BLOOD,
2. PEANUT HARVEST IN SUSSEX COUNTY, VIRGINIA, UNITED STATES,
3. PEANUT HARVEST AT SOUTHERA PINES, NORTH CAROLINA.



Plate XXXIX.



PEANUTS IN STACKS, SUSSEX COUNTY, VIRGINIA, UNITED STATES.



PICKING OF PEANUTS AT SOUTHERA PINES, NORTH CAROLINA.

they form and spread. As a rule, the pods are laid by the middle of July or the first of August (in America), and hence cultivation ceases about that time. It is all the more important, therefore, that land intended for this crop should first of all be thoroughly freed of weeds, and cultivated by means of surface-working implements with sufficient efficiency and thoroughness to keep the ground mellow and free from trash until the time when cultivation ceases.

As to the method of planting in the lowlands, ridge cultivation may sometimes prove the most desirable, but, as a rule, the peanut should not be planted in a bed. This statement is made advisedly, and as the result of both observation and experimental investigation.

HARVESTING.

Peanuts must be harvested before frost falls, as it injures both the vines and the kernels. The crop is generally harvested by means of a plough without a mouldboard, and which has a sword-like cutting share attached to the side. The knife passes under the row without injuring the nuts, and cuts the roots. Men following behind the plough with pitchforks shake the nuts free from the soil and pile them in windrows. Other labourers follow and stack them around poles 7 ft. high, which are set at convenient places in the field. Care is taken to see that the vines do not come in contact with the soil, and the nuts are placed on the outside of the stacks. After the stack has been completed, it is carefully covered with straw or grass, as a roofing to keep off the water during rainy weather. After curing in these stacks for a period of twenty days or more, the peanuts are ready to be picked. This work is usually performed by women and children, who are paid so much per bushel. It is slow and tedious work, and one of the greatest expenses of the peanut grower. After the peanuts are picked, they should be cleaned before being sacked, as they will command a better price. Most of the work of cleaning, of course, is done at the factory, which is proper, because of the facilities now available for the work. The peanuts, as a rule, are put in bags, which hold about 4 bushels, or 100 lb. Many attempts have been made to devise a machine which would pick peanuts, but most of those on the market at the present time cannot be regarded as altogether satisfactory, and it is likely a large part of the hand labour now necessary in preparing peanuts for the market will have to be continued for some time to come, though inventive genius will probably find a way out of this difficulty in the course of time.

VARIETIES.

There are a number of varieties of peanuts, which are cultivated quite extensively. The Virginia "bunch" and "running" are two of the most popular and widely known in the trade. Tennessee red and white are also quite extensively cultivated. The African variety is grown in North Carolina, and the Spanish in Louisiana. These are among the most satisfactory varieties cultivated at the present time.

YIELD.

The statistics of peanut production in the United States show some rather surprising figures so far as yield is concerned. The very low average yield obtained at the present time indicates that there is good reason for seeking improvement in the methods of cultivation and fertilisation of this important crop. Seed selection, as already mentioned, would undoubtedly have a great influence on increasing the yield; but, above all, it seems advisable at this time to again emphasise the importance of using liberal amounts of well-balanced fertilisers for this crop. If greater attention were given to the enrichment of the soil, which, as already pointed out is not well supplied with available plant food, the present yield could undoubtedly be doubled, and in many instances trebled. It seems surprising that more

attention has not been given to this important subject, since anyone may now obtain a fair understanding of the best methods to follow to insure the proper maintenance and nutrition of a given crop. The evidence at hand all goes to prove that liberal fertilisation will prove profitable. While small amounts of nitrogen may be necessary, potash, lime, and phosphoric acid should constitute the "trinity" of the peanut-grower.

CULTIVATION OF THE PEANUT.

Too much prominence cannot be given to the cultivation of the peanut. There is money in it. We have in Queensland a good market for the nuts for oil-producing purposes. They are also saleable in the Southern States for a like purpose, and also for confectioneries. Oversea, a steady market is to be found at remunerative prices. All things considered, a farmer with suitable land—a light, sandy, rich loam—cannot do better than devote a few acres to this crop.

We have just received the following article on the subject of peanuts from Mr. Henry A. Tardent, whose experience in various cultures is such as to entitle his opinions to serious consideration. He lately read a most interesting paper entitled

"A CHAT ABOUT A NEW SPORT FOR AUSTRALIA AND PEANUTS,"

before the Wynnum Literary and Debating Society, the first portion of which we omit, as we are more interested in his account of the peanut industry, in which he has proved the great value of the crop, the ease with which it is produced and harvested, and its ultimate financial results. The illustrations of the operations in peanut culture in the United States bear out all that Mr. Tardent describes, and, as "the proof of the pudding is in the eating," the photographs of one of Mr. Tardent's plants and of the single nuts are proof positive of what can be achieved by any farmer who has the proper soil suitable to the crop.

Mr. Tardent writes:—

"Another crop seldom seen in gardens hereabout, comes to us from Brazil, and is known to botanists under the name of *Arachis hypogea*. The French call it by the appropriate name of 'Pistache de Terre'; the Germans by that of 'Erdeichel,' or earth acorn. Here it is variously known as China-nut, Monkey-nut, Peanut, or Earth-nut—all names as erroneous as they are funny. The peanut is not a nut at all. It is a bean, with all the characteristics of the Leguminosæ family to which it belongs; but it is endowed with a peculiarity seldom met with in other plants. Instead of producing and ripening its fruits in the open, it buries and ripens them in the ground, away from both air and sunshine. The pistils of the yellow flowers extend into a kind of thread, which penetrates for from 3 to 4 in. into the soil. The fruit forms at the end of that thread first in the shape of a fluffy pod, which seems to act not only as a protection but also as a store of material for the twin kernels which are usually found in each pod. It is certainly one of the most curious plants in existence.

"The cultivation of the peanut is comparatively easy. Sow in deeply and well worked ground, in rows 3 ft. apart, the plants being about 15 in. apart in the rows for small varieties, and fully 2 ft. apart for the larger variety, of which I shall speak later on. Drop one pod (usually two kernels) for each plant. This will require about 2 bushels of seed to the acre of ordinary variety, and fully double that amount of the larger varieties.

"Keep the land free from weeds and well pulverised until the plants, which extend spider-like, in every direction, are beginning to cover the ground, when they should on no account be disturbed. Peanuts can be sown at any time in the Spring, after danger from frost is over, up till about Christmas. For South Queensland I prefer November and beginning of December, which allows of the harvesting being done five or six months later in April and May;

Plate XXXVII.



SINGLE STOOL OF GIANT PEANUTS.
Grown by Mr. H. A. Tardent, Wynnum.



Plate XL



GIANT PEANUTS—NATURAL SIZE.

thus allowing you to escape the only danger of losing your crop—namely, the propensity of the kernels to germinate before being harvested, if they happen to get ripe during the hot, moist weather. On well-drained land the plant will stand with impunity any amount of wet weather, and it resists drought admirably, being one of the hardiest of all cultivated plants.

“The peanut is ready for harvesting when the vines begin to show signs of fatigue. In a garden the harvesting is easily done by means of a fork with which you lift the plants, shake off the dust and dirt, and turn them upside down. In a large field, use a plough from which the mould-board has been taken off and replaced by a horizontal knife cutting the ground *under* the nuts. Men follow with forks, shaking the plants and heaping them in wind-rows. They are then stacked around poles 7 ft. high, care being taken that the vines do not touch the soil and that the nuts are turned outside the stack and exposed to both air and sunshine. Those stooks have to be topped with a straw, grass, or bulrush hat, or any other device capable of preventing the rain from penetrating into the stack. The plants must remain in that state for at least three or four weeks, that length of time being necessary for the complete formation of the oil or for what is known to peanut-growers as ‘curing.’ The nuts are then pulled off by hand, bagged, and stored in a dry, well-ventilated place until they are either consumed on the spot or sent to market. A bag usually holds about 4 bushels of nuts, or 100 lb. When freed from the nuts, the vines form an excellent, though somewhat coarse, fodder, to which all farm animals take kindly when the vines are chaffed and mixed with some other fodders.

“As to the peanut itself, it is the richest of all vegetable foods, and is greatly relished by man and most domestic animals. It is especially rich in fat, and produces a beautiful oil, second only to the product of the olive. Peanuts are also largely used in the manufacture of the finer soaps, and form an important part of the import of most European countries, especially of France.

“But, if I have dwelt at some length on the peanut, it is not so much on account of its commercial value, which is great, as I shall show later on, as because it is such an excellent esculent, relished with equal eagerness by both young and old. I, therefore, hope that the anticipation of such a delicious crop to come might induce some of my young Australian friends to devote a few hours every week to the invigorating and profitable sport of gardening. For there is no denying the fact that the peanuts are a dainty delicacy. When boiled in salt water, or, still better, baked in a somewhat cool oven, they have a fine hazel-nut taste, hardly surpassed by that of any other nut. They are specially good for growing children. Doctors not seldom recommend their use to consumptives and other people with weak chests.

“As stated above, there are several varieties of peanuts, but here, in Australia, I have seen only two—the ordinary little dwarf, mostly grown by Chinamen and retailed by most fruiterers, and the ‘Giant.’ The latter is the one (here illustrated), which we planted in our Wynnum garden. True, we had to pay a stiff price for the seeds—no less than 1s. 6d. *per pint*—to our friend Mr. Wood, the Brisbane seedsman in George street; but the results have justified our speculation in expensive seeds, for the latter have developed into magnificent plants with deep tap roots and widely-spreading stems. They yielded at the average rate of about 100 good pods or nuts per plant. As fifty ‘Giants’ go to make 1 lb., this is equivalent to 2 lb. per plant, or considerably over 4 tons (8,960 lb.) to the acre. Of course, it would not be wise to always reckon on such yields, 2 tons being nearer the average crop of the average grower. Even at that rate, peanut-growing pays better than horse-racing (when you win at the latter game, which is seldom the case), whilst in gardening you are always on the winning side. At current market prices an acre of peanuts may run up fairly near to the three figures, whilst at the price we paid for our seeds you would have to reckon by hundreds.

"This being so, how is it that so few of our farmers and others go in for this crop? I really think that, if the peanut were better known, there would not be a single farm, station, school, villa, or cottage garden without its large or small plot of peanuts, which would supply both man and farm animals with that proportion of healthy vegetable fat which should never be wanting from a healthy and well-balanced diet."

LAND EROSION.

Those who, in this State, are cultivating hilly land, cannot fail to have observed that during heavy rains quantities of soil are worked down from the cultivated land to the level country below. Especially does this erosion occur on ridgy scrub lands when once the stumps have been removed and the land has been cultivated; and the best remedy is to sow the land down with artificial grasses. This has been found necessary on some of the sugar lands in the Blackall Range.

Practically all hilly and rolling land is subject to erosion if the climate be a humid one. In such a climate rain-storms are frequently of long duration, while the thunder-storms are often of great severity, an immense amount of water falling in a short time. Sloping land is eroded before the owners know it, if they have not taken precautions against the erosion by leaving on the land its natural cover of trees or grass.

More than one nation of the old world has found its mountain tops rendered worthless by erosion. A notable case is that of the Jura Mountains, in France. There was a time when the tops of those mountains produced grass in such abundance that cattle, sheep, and goats were pastured on them in great numbers. But in course of time the private owners of the forests cut off the wood. Then followed erosion and the practical ruining of the grazing lands. The damage was done before the Government or the people awoke to the situation. The very rocks were washed bare of the soil that had been collecting for ten thousands of years. It was found that private enterprise could not be depended on to repair the damage, and the Government undertook the task. Soil had to be carried to the tops of the mountains. To prevent this new soil from being washed away before the roots of the trees could bind it together, small dams of stone had to be built supporting the soil. Then evergreens were planted. The work has been going on a quarter of a century or more, and it is expected to continue for more than a century from this time, so great is the task of bringing back the land to a condition in which erosion will not be possible. The measures taken to prevent a repetition of the trouble point a lesson as to how erosion of such soil may be prevented.

WASHINGTON WHITEWASH.

This is an excellent wash for house-roofs or elsewhere. If properly made it will neither wash off nor rub off, and has the appearance of paint. It is so named from the fact that the "White House" at Washington, the official residence of the President of the United States, is coated with it. The formula is as follows:—Slake a bushel of quicklime in a barrel, covering with a bag while the lime is working; melt 1 lb. of common glue to a thin size; make 1½ lb. of ground rice into a thin paste with boiling water; mix up 1 lb. whiting as you would mustard. When the lime is quite slaked, add the glue, whiting, and rice-paste and a half-peck of common salt. Mix well and let stand for forty-eight hours, keeping covered. Thin down to consistency of ordinary whatewash, and apply hot.—"Journal of Agriculture," South Australia.

Dairying.

THE DAIRY HERD, QUEENSLAND AGRICULTURAL COLLEGE, GATTON.

RECORD OF COWS FOR MONTH OF APRIL, 1909.

| Number. | Cow's Name. | Breed. | Date of Calving. | Total | Average | Commer- | Remarks. |
|---------|----------------|-------------------|------------------|-------|--------------------|-----------------|----------|
| | | | | Milk. | Test,
Per cent. | cial
Butter. | |
| | | | | Lb. | | Lb. | |
| 1 | Lubra ... | Jersey-Ayrshire | 5 April, 1909 | 722 | 4.3 | 34.75 | |
| 2 | College Lass | Ayr-hire ... | 31 Jan. " | 872 | 3.5 | 33.82 | |
| 3 | Nellie II. ... | Shorthorn ... | 25 Feb. " | 735 | 4.1 | 33.70 | |
| 4 | Butter ... | " ... | 20 Feb. " | 815 | 3.6 | 32.60 | |
| 5 | Glen ... | Grade Shorthorn | 29 Jan. " | 718 | 3.8 | 30.39 | |
| 6 | Whitefoot ... | Holstein-Devon | 20 Oct. 1908 | 613 | 4.0 | 27.26 | |
| 7 | Laura ... | Ayrshire ... | 16 Nov. " | 671 | 3.6 | 26.84 | |
| 8 | Linda ... | " ... | 11 April, 1909 | 733 | 3.3 | 26.71 | |
| 9 | Rosalie ... | " ... | 10 Feb. " | 684 | 3.5 | 26.54 | |
| 10 | Honeycombe | Shorthorn ... | 11 April " | 581 | 4.0 | 25.96 | |
| 11 | Bangle ... | " ... | 23 Feb. " | 564 | 4.1 | 25.87 | |
| 12 | Blackbird ... | Grade Holstein .. | 4 Feb. " | 600 | 3.7 | 24.70 | |
| 13 | Maud II. ... | Shorthorn ... | 16 Jan. " | 547 | 4.0 | 24.53 | |
| 14 | Lady Ring | Guernsey ... | 26 Jan. " | 450 | 4.8 | 24.34 | |
| 15 | Rennet ... | Holstein ... | 19 Mar. " | 589 | 3.7 | 24.24 | |
| 16 | Dot ... | Shorthorn ... | 12 Nov., 1908 | 625 | 3.4 | 23.51 | |
| 17 | Daisy ... | Holstein ... | 24 Oct. " | 664 | 3.2 | 23.42 | |
| 18 | Comet ... | " ... | 22 Nov. " | 565 | 3.7 | 23.25 | |
| 19 | Dewdrop ... | " ... | 11 Nov. " | 573 | 3.5 | 22.23 | |
| 20 | Dora ... | Shorthorn ... | 18 Nov. " | 563 | 3.5 | 21.84 | |
| 21 | Graceful ... | Grade Shorthorn | 10 Dec. " | 420 | 4.5 | 21.24 | |
| 22 | Gem ... | " ... | 13 Dec. " | 450 | 4.2 | 21.17 | |
| 23 | Beauty ... | Ayrshire ... | 11 April, 1909 | 554 | 3.4 | 20.85 | |
| 24 | Nancy ... | Grade Shorthorn | 7 May, 1908 | 434 | 4.2 | 20.41 | |
| 25 | Careless ... | Jersey ... | 7 Dec. " | 480 | 3.8 | 20.32 | |
| 26 | Ethel ... | Grade Holstein... | 3 Sept. " | 508 | 3.6 | 20.32 | |
| 27 | Len ... | Ayrshire... | 6 May " | 480 | 3.7 | 19.76 | |
| 28 | No. 112 ... | Grade Guernsey | 24 Nov. " | 390 | 4.5 | 19.72 | |
| 29 | Poppy ... | " ... | 10 Jan., 1909 | 510 | 3.3 | 18.59 | |
| 30 | Orange ... | " ... | 23 Oct., 1908 | 300 | 5.2 | 17.70 | |
| 31 | Nestor ... | Grade Shorthorn | 4 Mar. 1909 | 476 | 3.3 | 17.34 | |
| 32 | Lowla ... | Ayrshire... | 8 Dec. 1908 | 491 | 3.2 | 17.31 | |
| 33 | Donah ... | Holstein ... | 13 Oct. " | 472 | 3.3 | 17.20 | |

DAILY FEEDING RATIIONS FOR MILCH COWS.

The following rations for milch cows (given in an English contemporary) are calculated per 10 cwt. and not per 1,000 lb. live weight, as it is probable that 10 cwt. is about the average live weight of good milch cows in the North of England. For cows of a greater or less weight than 10 cwt. the feeding rations should be increased or decreased in direct proportion to their weights, provided the quantity of milk given is also greater or less in the same proportion:—

No. 1.—Ration for cows giving 18½ lb. of milk (roughly 1⅝ gallons) per day. Quantities for cows 9 cwt. live weight and giving 16½ lb. of milk daily are given within brackets.

39 lb. swedes or 52 lb. yellow turnips (35 lb. or 47 lb.)

19 lb. oat straw (17 lb.)

4¾ lb. decorticated cotton cake (4¼ lb.)

Roughly speaking, 1 lb. less of decorticated cotton cake might be given if the yield is 12½ lb. of milk daily instead of 18½ lb. daily.

No. 2.—Ration for cows giving $30\frac{1}{2}$ lb. of milk (roughly 3 gallons) per day. Quantities for cows 9 cwt. live weight and giving $27\frac{1}{2}$ lb. of milk daily are given within brackets.

- 46 $\frac{1}{2}$ lb. swedes or 62 lb. yellow turnips (42 lb. or 56 lb.)
- 19 lb. oat straw (17 lb.)
- 6 $\frac{3}{8}$ lb. decorticated cotton cake (6 lb.)
- 4 $\frac{1}{2}$ lb. undecorticated cotton cake (4 lb.)

No. 3.—As for No. 2, with hay instead of oat straw. Quantities for cows 9 cwt. live weight and giving $27\frac{1}{2}$ lb. of milk daily are given within brackets.

- 46 $\frac{1}{2}$ lb. swedes or 62 lb. yellow turnips (42 lb. or 56 lb.)
- 19 lb. meadow hay (17 lb.)
- 5 lb. decorticated cotton cake (4 $\frac{1}{2}$ lb.)
- 3 $\frac{3}{8}$ lb. Indian cotton cake (3 $\frac{1}{4}$ lb.)

Heavy milkers, giving about 4 gallons of milk daily, should have all the foods of the best quality possible, and could receive an addition like one of the following to that of Ration No. 3:—

- 2 lb. seeds hay, 2 lb. linseed cake, 1 lb. maize meal; or 2 lb. linseed cake, 2 $\frac{1}{2}$ lb. maize meal.

Ration No. 1 might also have been substituted for oat straw, and, if so, the decorticated cotton cake should be reduced by about 2 lb. daily. This, however, is not quite an exact equivalent.

Any of these rations can have the roots considerably reduced by using a substitute for roots, as indicated at the beginning of this section.

Cows giving reduced quantities of milk as the lactation period progresses should have the concentrated food given to them reduced, but cows that are heavy milkers, and have become reduced in condition, owing to their heavy milk yields, must not have the food reduced too quickly, to allow them to regain condition before coming to the next calving.

When cows are to be fattened off at the close of their milking periods, the ration should not be reduced as indicated above, but should have the ration gradually altered to that suitable for fattening animals as the flow of milk decreases.

Cows of 10 cwt. live weight, dried off previous to calving, would probably do well with either of the following quantities:—

Quantities for cows of 9 cwt. live weight are given within brackets.

- No. 1.—39 lb. swedes or 52 lb. yellow turnips (35 lb. or 47 lb.)
- 19 lb. oat straw (17 lb.)
- 2 $\frac{3}{4}$ lb. maize meal (2 $\frac{1}{2}$ lb.)
- 2 $\frac{1}{2}$ lb. decorticated cotton cake (2 $\frac{1}{4}$ lb.)

- No. 2.—39 lb. swedes or 52 lb. yellow turnips (35 lb. or 47 lb.)
- 19 lb. meadow hay (17 lb.)
- 2 $\frac{1}{4}$ lb. maize meal (2 lb.)
- $\frac{2}{7}$ lb. decorticated cotton cake ($\frac{1}{4}$ lb.)

Additional water should be given to that contained in any of the foregoing rations, so that in all cases the cows should have access to water.

The Guernsey, as follows:—

| | lb. Milk. | lb. Butter Fat. |
|-----------------------------|-----------|-----------------|
| Two-year-old class | 5,000 | 200 |
| Three-year-old class | 6,000 | 240 |
| Four-year-old class | 7,000 | 280 |
| Mature class | 8,000 | 320 |

The Holstein-Friesian, as follows:—

| | lb. Milk. | lb. Butter Fat. |
|-----------------------------|-----------|-----------------|
| Two-year-old class | 7,500 | 255 |
| Three-year-old class | 8,500 | 289 |
| Four-year-old class | 9,500 | 323 |
| Mature class | 10,500 | 357 |

And, lastly, the Jersey, as follows:—

| | ... | ... | ... | Lb. Milk. | ... | Lb. Butter Fat. |
|----------------------|-----|-----|-----|-----------|-----|-----------------|
| Two-year-old class | ... | ... | ... | 5,500 | ... | 218 |
| Three-year-old class | ... | ... | ... | 6,500 | ... | 257 |
| Four-year-old class | ... | ... | ... | 7,500 | ... | 297 |
| Mature class | ... | ... | ... | 8,500 | ... | 337 |

Some of the yields are given, from which it may be inferred that a good start has been made with some of the best milking cows in the country. The Ayrshire, for instance, that gives 11,357 lb. of milk and 409.95 lb. of butter fat in the year, equivalent to an average of 3.6 per cent., is worth having. Her highest yield during any month was 1,302 in November. Still better, however, was the performance of Daisy Queen, which gave 13,158.3 lb. of milk and 485.39 lb. of butter fat, her highest monthly yield being 1,543 lb. in June. Then, again, Daisy of Carlheim gave 12,297 lb. of milk in the year and 3.15 per cent. fat. Other Ayrshire yields include 10,202 lb. of milk, 11,222 lb. of milk, &c.

THE VALUE OF GRADING BUTTER.

The prominence gained by the Queensland butter in the dairy section at the Royal Show has (says the "S. M. Herald") aroused considerable comment amongst dairymen and others interested in the industry.

The success, it is urged by those competent to express an opinion, is due principally to the system of grading and proper supervision brought about by the Queensland Government in place of the happy-go-lucky methods which have so far prevailed in this State. All the prizes in the section were not gained by the northern State, but important awards were appropriated from what are considered our leading factories. The success of the Warwick Dairy and Butter Company in the class provided for butter salted and manufactured ready for export and that of the Dalby Butter Factory in the unsalted class are awards which are largely competed for, and around which a great deal of interest centres.

In view of this fact an expression of opinion was sought from a well-known gentleman connected with the industry. He stated that the result of the competition had not come as a surprise to him. The northern butter was of exceptionally good quality throughout, and its success was without doubt due entirely to the operation of the excellent Dairy Act in force in Queensland, which provided not only for proper grading, but also instruction and assistance generally. To his mind there was in some quarters an unaccountable spirit of misunderstanding prevailing in this State regarding dairy and factory requirements, and until those in the industry realised how they were lagging behind their butter would not meet with any measure of success. The result of the judging this year was one of the biggest object lessons yet placed before us, and we should certainly profit by it. What was required was a new dairying Act, covering compulsory grading and instruction to farmers and factory managers.

"First and foremost," continued the gentleman interviewed, "you must make the factory manager an educational factor in his own district. He is the man whom the supplier looks to for sound practical guidance in the delivery of the raw product in good condition. This may mean apparent hardship to the producer, who should not be allowed to pool his cream, and might mean cartage over bad roads; but, at the same time, the keynote of the situation is quality, and no manager can get near this if the cream or milk supplied is invaded with dirt or false organisms. Hence, I say, it is absolutely necessary that the manager should have a knowledge of fermented processes, their origin and control. This means education of a technical nature,

involving an elementary knowledge of bacteriology and a familiarity of the principles of testing, which can only be acquired as the result of laboratory training. These essentials appear to be lacking in this State, hence the necessity for agriculture to get to the bedrock of the cause of the failure of price and quality. The aim of the department should be to provide a thoroughly sound technical training in the manufacture of butter and cheese, combined with an absolute knowledge of how to educate the farmer in the delivery of the raw product.

“Moreover, factory managers should be required to pass an examination, and hold a certificate of competency. This in itself would be an assurance to a board of directors that they were employing a man who could assist their shareholders. This has already been accomplished in New Zealand, Victoria, and recently Queensland, where managers are given ample opportunities at the various colleges and the assistance of travelling experts to bring up the grade of butter. This work must be done before a marked improvement can be effected by grading. And then, again, the graders at the port of shipment should be specially selected men, whose educational training and knowledge of grading have been acquired in the factories themselves, and who are known to possess a good palate and keen judgment; because the most important feature of the whole work is that where faults are discovered at the port of shipment, the factory manager in question should be promptly informed. Should the communication fail to produce an improvement, a competent man should be despatched to the factory to investigate local conditions, and ascertain the cause of the trouble, and stay there until an improvement has been effected. In this way the supplier would reap the benefit, and I venture to say that with this system continually in operation all weak factories would have the standard of their products raised, and we would get rid of third and fourth qualities.

“A great deal has yet to be done in educating the farmer as to the necessity for sanitary surroundings, in the raising of the grade of his cattle, and in encouraging a system of stall-feeding during periods of scarcity, such as mid-winter and mid-summer. In this regard, too, the advantages of the conservation of fodder, particularly maize ensilage, will have to be impressed upon dairymen; and when farmers realise this they will materially increase their income, and the quality of the butter will be immeasurably better.

“The men sent out to educate managers and farmers should be in no wise called inspectors, but rather instructors. Their concern should be purely with the man who milks the cow, and their advice and assistance should be welcome at every farm. Then, and only then, will our butter maintain a high standard of quality, and be in a position to successfully compete with samples from those States where the industry is carried on on thoroughly progressive lines.”

DEHORNING COWS.

Experiments were recently made at one of the American agricultural stations with a view of ascertaining whether the operation of dehorning dairy cows was painful. In several cases the per cent. of butter fat had been noted at each milking for a few days before and after dehorning, and from these a fair estimate was arrived at of the effect of dehorning on the dairy cow.

At one experiment station a record of ten cows was kept. Each cow was tested two milkings before dehorning and four milkings after dehorning. In every case but one, the milk tested much lower at the milking immediately after dehorning. The test gradually increased, until it was much higher than it had been in the milkings previous to dehornings, and the actual amount of butter fat produced by the cows was as much or more than it would have been had the cows not been dehorned.

At another time, at the same station, 12 cows were dehorned, with a loss of 5 per cent. in the total yield of milk in six days after dehorning and a gain of 4 per cent. in the total amount of fat produced in the same time. A record of the weight of the cows before and after showed practically no loss due to the operations. At another station 14 cows were dehorned. Most of them fell off in their milk slightly, but gained in per cent. of butter fat, and at the fourth milking all were back to their normal flow: The 14 cows made about 1 lb. less in the two days following dehorning than they had made in the two previous days.

From these reports it appears that there is a very small percentage of loss in the total amount of the milk produced, and very little, if any, loss in the total fat produced, in the first few milkings following dehorning. In the majority of recorded trials the cows came back to their natural flow of milk in less than a week, often in two days. Judging from this the pain suffered by the cow must be slight.—“Australian Gardener.”

A CURIOUS COW.

Dr. James Anderson, in his “Recreations in Agriculture,” mentions a very curious cow (says the “Live Stock Journal”). “I know one,” he says, “which yielded abundance of milk, but from which no butter could ever be obtained by any process that could be devised, and it is not a little remarkable that that cow had been kept for several years by one person without its ever being discovered or even suspected that her milk had that quality. The milk had always been mixed with that of others, as is usual in large dairies, and it probably would never have been discovered at all had she not been sold to a person who kept no more than one cow.”

[It would be interesting to know if any such phenomenal milk has been ever produced by an Australian cow.—Ed. “Q.A.J.”]

STRAW BUTTER BOXES.

An English journal credits Queensland with the formation of a company with a capital of £50,000, for the manufacture of straw butter boxes. It also states that butter boxes have hitherto been made of pine, but the drain upon this timber owing to the heavy exports has been so severe that the wood is rapidly going up in price. One can understand this on noting that in one month (March, 1908) over 50,000 boxes of butter arrived from Queensland in this country; 1,250 tons, worth £140,000. The new box is made of barley straw. In its manufacture a mixture of kaolin and straw is used. It can be produced and sold for 1s. At present 3,000,000 boxes are used in Australia annually, costing £200,000. The new boxes will save the dairy industry about £40,000 a year. The material for manufacturing the box can be grown in the same paddock that supports the cow. The new type of box is in every respect equal to the old. It weighs about 10½ lb., is damp-proof, and odourless.

[Straw butter boxes have never been manufactured in Queensland. They were made in Victoria, and, we understand, were compound of straw laid horizontally, and mixed with kaolin. On a trial of these boxes being made to ascertain if they would bear the strain of a load of a layer of twenty boxes, it was found that they collapsed under a load of eleven boxes. This led to an improvement in that the straw was placed perpendicularly. We have not heard how this different position of the straw has increased the resistant power of the sides of the boxes.—Ed. “Q.A.J.”]

Poultry.

PREPARING POULTRY FOR SHOW.

There are two chief points in preparing a bird for the showroom—first, quietness; and second, cleanliness.

By quietness is meant birds that are easily handled, and will not be scared nearly to death when in a coop. The fancier can train his birds for the show just as a horse is trained for a race. Starting, say, a month before the show, the birds that are to be exhibited should be handled as much as possible, so as to get them good and tame. If the show specimens are placed in a coop at night, and fed in the morning before letting them out, they will soon become used to the coop. While shut up, they should be taken out of the coop and handled, just as a judge would handle them at a show. A short cane should be kept handy, and the bird taught to pose when touched with it. If this treatment is kept up, your birds will show up far better than your neighbours' birds that have not had such good preparation.

While your birds are showing themselves off to the best advantage, your friends' untrained birds are huddled up in the far end of the coop, and are afraid to stand up for inspection. Thus it will be seen that much is to be gained by training your birds for the show, for, even if your birds are not quite as good as the other fellow's, your specimens will show up far better than the other party's scared-to-death birds. Anyone who has ever visited a show knows that the above is perfectly true, and, while some birds were looking their best, some others would be found huddled up in the back end of the coop.

In the second place, your birds must be clean from beak to toe, and most birds are the better for a good washing. Of course, if your birds are not white, and the plumage looks good and clean, then it is not advisable to wash them unless you understand the job from start to finish, for the writer remembers the mess he made of the first birds he attempted to wash. But most all white birds are better for a thorough washing. To successfully wash a bird, you will want three tubs. In tub No. 1 place clear warm water; in the second, warm water with a quantity of soap dissolved in it and made into suds, and tub No. 3, containing warm water with a little bluing added. An assistant is necessary, for one person cannot manage alone very well. Now bring in your birds (you should borrow the kitchen for the job), and provide a light coop for them. Catch a bird, and, while your assistant holds it in the water of tub No. 1, you should thoroughly wet all the feathers. Be sure and have all the plumage well soaked. Now, squeeze out as much water as you can, and then place in tub No. 2. And now the real work commences. Take a bunch of feathers in one hand, and thoroughly wash them with the other. Don't be afraid of hurting the feathers, for a wet feather will stand a lot of rubbing. A tooth-brush should be used to clean the legs and feet, being sure to get all the dirt out of the cracks and corners. The water should be pressed out of the feathers as much as possible, and the bird is now put into No. 1 tub again, and all the soapy water rinsed out of the plumage. Now place your bird in the third tub, and be sure and get the blue-water thoroughly into the feathers. Press out as nearly dry as possible, and give the bird a toss up in the air to get the feathers loosened up, and then place in the coop to dry. Be sure you get the head and feet perfectly clean. Before sending or taking your birds to the show, rub up their legs with a soft cloth to which a little vaseline has been applied. The comb and the wattles should be treated in the same manner. If you don't wash the plumage, be sure and clean head and feet, for a bird with dirty legs and feet is not a nice specimen for a judge to handle, and he will give preference to the clean bird every time.

BUYING POULTRY.

The poultry industry owes much to the fancier, for had the poultry farmer no source from which to acquire new blood he would soon find his profits diminishing.

The fancier aims to keep the breed or breeds in which he is interested up to the highest standard of perfection, and little does the general public realise the time and expense which this entails. No one will ever succeed as a breeder of prize poultry who does not possess, in addition to a genuine love for his feathered pets, an unlimited amount of patience and perseverance. One year his birds carry everything before them, but next season the other man is successful, and appropriates all the honours.

Even with the most prominent and successful exhibitor, the number of young stock it is necessary to hatch and rear, from which to select a team that will do him justice in the show pen, incurs an expense which the casual visitor at a poultry show would hardly credit. If there is an average of five fowls out of every hundred reared, possessed of sufficient merit to do their owner credit in the show pen, that owner can consider himself fortunate indeed, whilst in some breeds, such as silver or gold-laced Wyandottes, owing to the difficulty in breeding well laced plumage, the average is much lower.

Small wonder is it, therefore, that the fancier asks a price for his winners that the lay mind thinks extortionate, but when all expenses are taken into account, even if the breeder were to sell all his winning birds at these figures he would not make a profit. Breeders of the present day value their reputation so highly that they will not keep an inferior specimen, but kill all "culls" as soon as they are old enough for table purposes. Every season lots of people are very anxious to buy these "culls" at the price of table birds, but the fancier who desires to make or maintain a prominent place amongst the "fancy" steadfastly refuses to sell them alive, as nothing would more quickly lead to his undoing than to allow to be seen by the public a lot of "scalawags," which are declared by their owner to be bred direct from "So-and-So's" birds. Sooner than let this happen, would any leading breeder wring the neck of every bird not up to a reasonable standard and burn them.

Thus it is that no rubbish ever leaves a reliable breeder's yard, and so the public are protected from having inferior poultry foisted upon them. When a good quality of poultry is required, let the buyer patronise a reputable fancier and be prepared to pay a fair price for a good article, and both parties to the deal will be satisfied.

DESTROYING CATERPILLARS.

A novel method of dealing with the caterpillar pest has been described to a representative of the "North Otago Times." In the early days of the North Otago district caterpillars were a greater scourge than they are in these days of the small bird pest, and a farmer in the district determined to try a method he had seen in operation in South Australia. He noticed that for about a chain wide and several chains long myriads of caterpillars had settled down on his crop, and were destroying the heads of grain. He took the rope reins from a team, and he and his ploughman, stretching these across the affected part of the crops, at about 6 in. below the tops of the heads, marched along with the rope taut. The grain bent down as the rope passed along, and when freed of the pressure, sprang back with a jerk, throwing every caterpillar to the ground. Natural instinct warned the insects of danger, and they swarmed out of the crop and on to the road, where an opportune "north-wester" shrivelled them up.

The Horse.

GRIPES.

Colic is the exhibition of pain in the interior of the abdomen. It is a symptom of many diseases, such as indigestion, worms, rupture, obstruction, inflammation, &c.

In treating a horse for gripes the person prescribing should try and first ascertain the cause. The great danger with horses subject to colic is that they cannot vomit, and other means of relief must be sought for.

The symptoms are: Disinclination to work, uneasiness, pawing with fore feet, arching the back and making attempts to lie down. As the trouble gets worse, the animal makes efforts to cow-kick at his belly, the pulse is frequent, breathing difficult at times, and the body more or less perspiring. The best symptom is when the pain is intermittent. Unfavourable symptoms are high temperature, cold and wet perspiration, and a haggard expression of the face. If the horse stales easily, it is a very hopeful sign.

The treatment of colic is various. The majority of cases would recover if left alone. Purging, turpentine irritation, strong drenches, &c., increase the mischief. Linseed oil is good as a soothing and mild aperient. Chlorodyne and a quart of warm ale with a little spirits often work wonders.

Keep the horse quiet in his stall, with plenty of bedding under him, so that he may relieve himself by rolling. One or two enemas of warm water act well. A catheter should be passed if the urine is not voided. In serious cases expert treatment in regard to drug-giving should be at once obtained.

RINGWORM ON HORSES.

Last month we gave a remedy for ringworm on horses, and also mentioned the cause of the affection. A writer in the "Farmer and Stockbreeder," London, says that ringworm spores reside in old woodwork, both indoors and out, and that he knows fenced yards where it just as surely occurs as the stock are put in them. The occupier pays annually as much for attendance and veterinary dressings as would suffice to fence one section each year, and eradicate it, but, like many others, he only half believes in the sources of infection. In mossy and in peaty soils the spores may remain and infect animals lying on them, but a frequently-overlooked purveyor of ringworm of late years is peat-moss litter, which, when moist with urine and warmed by slight fermentation, is a perfect generating station. If this is spread on land it ensures the reproduction of ringworm. Stockholm tar, made warm and laid on with a brush, is the safest and most lasting for trees and fences. Inside of buildings the stock can be dressed with 1 lb. of chlorinated lime, shaken daily, with 2 gallons of water, in a stone bottle, and used after the third day or any subsequent date, as it will keep until the bung gets eaten away. A penetrating and effective dressing for cattle is made of 1 part of creosote and 7 parts of fish oil.

Horticulture

FLOWER GARDENING, No. 17.

PLANTS SUITABLE FOR IN AND OUT DOOR CULTURE.

By THE EDITOR.

ORCHIDS.

For the successful cultivation of the larger part of this peculiar and delightful race of plants, an atmosphere, either naturally humid, or rendered so artificially, is absolutely essential. The most beautiful of our Queensland Orchids are to be found in the warm, humid, tropical scrubs of North Queensland, but many desirable kinds are obtainable in the riverine and mountain scrubs of the Southern coast, and, notably, in those of the fairly humid Blackall Range.

It was, at one time, considered that Orchids could only be successfully cultivated in glass conservatories, but it has been conclusively proved that, from the want of sufficient ventilation, probably, such depositories are not well suited for them. One main point in the treatment of Orchids, formerly not given due attention to, was a sufficiency of light. It is a mistake to think that these plants live in the dark in their native localities, and that a situation where no sun can reach them is the one best adapted to them. They live, it is true, in the shade cast by the foliage of the trees on which they are suspended or beneath which they grow; but that foliage is not altogether, and at all times, impervious to the rays of the sun; and, moreover, when the trees lose their leaves, as many do, during the cold months, the plants must needs be subject to a very considerable exposure to full sunshine. This would have the effect of ripening their wood, and thus causing them to bloom. It becomes a question, then, if there be not those which it would be desirable to remove from the shade house and subject to the full influence of the sun during, at least, some portion of the year. Orchids are either terrestrial or epiphytal, the former growing in the soil, the latter attached to trees or rocks, hence the name of air plants, which has been given them, their chief sustenance being derived from the atmosphere. Most of the terrestrial species are natives of temperate climates, while the majority of the epiphytal species are natives of tropical zones. Some of these require a very high temperature, while others that are found on mountains, or outside the tropics, thrive in a lower temperature, so that, from a cultural point of view, houses of different temperatures must be provided.

In India, some Orchids are grown in what are called "Betel Houses." The Betel house, in which the Betel plant has been cultivated from time immemorial, is practically our Queensland bush-house, and as Orchids are lovers of light and air, ventilation is consequently necessary, and therefore, our open bush-houses suit many kinds admirably, provided the plants are not placed in draughty positions. Even the varieties which are shade-loving, require light, though not direct sunshine, for they will not thrive in dark corners. All like a moist atmosphere when in a growing state, and, as their life is sustained by the moisture they obtain from the air, the surroundings

ERRATUM.

In my notice of the *Duranta*, it was stated that *Duranta Ellisii* has white flowers. This is an obvious error, the flowers of this variety being dark blue. *D. plumieri*, var. 1 *Alba*, is white flowered.

There is a pretty blue flowering *Duranta* in the Executive Garden, Brisbane, which has variegated foliage—green and white.

should always be kept damp when the plants are in full vigour of growth. I have grown some beautiful Orchids from New Guinea with no other shade than that afforded by peach trees, which, as we know, are deciduous, and hence leafless for several months of the year.

These considerations lead us to the matter of

ORCHID HOUSES.

These are classed according to the climate of the country from which the Orchids emanate, and also according to the temperature in their native habitat. Thus, we have

The East India House, for plants from low elevations in India and other parts of the tropics, in which the temperature should range from 70 to 75 deg. Fahr. by day, and from 65 to 70 deg. by night.

The Brazilian House, which will accommodate all the plants from the low regions of the Western Hemisphere, in which the temperature may be allowed to fall to 65 deg. by day, and to 60 deg. by night.

The Peruvian House will include the mountain plants from the Western, or, as it might be called by Australians, the Eastern World, and most of the natives of Australia, for which a temperature of 60 deg. by day, and 55 deg. by night will suffice.

Then there is the Cattleya House, the Intermediate House, and the Cool, or Odontoglossum House, with temperatures varying from 60 to 65 deg. by day, to from 50 to 60 deg. by night.

A large proportion of epiphytal Orchids prefer shade, but others, such as some of the *Lælias*, *Coryanthus*, and similar genera, thrive best when close to the glass, and love full exposure to the rays of the sun; therefore, a portion of the Orchid house should be entirely devoted to them, so that their requirements in that direction may be met.

The common practice in the culture of Orchids is to devote a house entirely to them, but not only is it more congenial to their nature to grow amongst other tropical plants, but a better effect may be thereby produced, for Orchids, when not in flower, are not particularly enticing. It is, therefore, advisable to introduce, at any rate, to the East Indian House, some of the tropical Tree and other Ferns, climbing Aroids, *Nepenthes*, and the smaller-growing Palms, which, standing above the Orchids, furnish a grateful shade, and, their stems being slender, they form no objectionable obstruction.

Most of the above I have taken the liberty of reproducing from the useful little book on Australian Gardening, by Mr. W. Adamson, and now repeat the following directions for propagating Orchids, given by Mr. B. S. Williams in "The Orchid Grower's Manual":—

Some are easily increased by dividing them into pieces, or by cutting the old pseudo-bulbs from the plants after the latter have done flowering. Such plants as *Dendrobium* are increased in this way. The best time for this is just as they begin to grow, or when they are at rest. They should be cut through with a sharp knife, between the pseudo-bulbs, being careful not to hurt the roots. Each piece should have some roots attached to it. They should be parted and potted, and receive no water until they begin to grow.

Dendrobium nobile, *D. Pieradii*, &c., are propagated—

1. By bending the old pseudo-bulb round the basket or pot in which they are growing.
2. By cutting old flowering bulbs away from the plant, laying them on damp moss, and, when they make roots, potting.

D. aggregatum, *D. densiflorum*, and similar plants are increased by dividing the roots.

Aerides; *Vanda*; *Angraecum*; *Saccolabium*; *Renanthera*—

1. Cut off the top of the plant, just below the first root.
2. Take young growth from the bottom of the plant.

Epidendrum; *Cymbidium*; *Cælogyne*; *Cattleya*; *Bletia*, and many others—

Divide into pieces with portions of the roots attached, and a young bulb on the pseudo-bulb.

Different modes of growing them are adopted, suited to the peculiar habit of each. Some thrive best fastened with moss upon the bough of a tree, or upon a log, some in open-work baskets of wire or wood, and some few in pots. The time for re-potting such as are grown in pots, is at the close of the period of rest, just as they begin to start into growth. Previous to potting it is laid down as indispensable that they receive no water for a few days. The mode of potting is very simple. Within the pot to be used, place a smaller one turned upside down. Between the two pots, put large lumps of broken brick and charcoal, and fill up to the rim with pieces smaller and smaller. Upon these spread out the roots of the plants, and cover them with small pieces of the same material. To keep the plant steady, insert a couple of stout sticks to tie it to.

When grown in suspended baskets, the baskets may be so designed as to be very pleasing ornaments themselves. The material with which the baskets are filled will be the same as that used in the pots.

To grow them on logs, they must be bound on with copper wire, protected first with moss or cocoa-nut fibre.

Another authority says:—In potting or basketing Orchids, care should be taken that the eyes of the plant are not covered. They are always at the base of the previous year's growth, and it is of vital importance that the potting material does not cover them. Fill the receptacle partly with broken crocks, cover this with some moss or similar material to prevent the compost from clogging the drainage; then add the compost, and see that the Orchid is potted firmly and staked so that it is fairly rigid. If any of the roots are dead or broken, it is better to sever them with a sharp knife. See that the roots are not bruised or broken in any way when potting, and above all do not over-pot. Orchids, as a rule, do better in small receptacles than in large ones. To a beginner this may be difficult to understand; but it is a fact worth remembering. Do not allow the compost to become wet or sour, or the plants will not thrive, and be attacked by disease.

THE ORCHID-GROWER'S START.

To become a successful Orchid-grower, demands far greater study and steady application than are required for general horticulture. The conditions under which Orchids thrive in their native habitats are so varied, that success can only be attained by those who make a serious study of those conditions, and strive to reproduce them under totally different climatic exigencies.

In commencing to get together a collection of Orchids, the beginner will do well to start with the varieties that find their native habitat in Queensland. The purple varieties from North Queensland are fairly common in Brisbane, yet how few people make them do well. I saw some quite recently on a friend's veranda post—upside down, tied loosely, and in such a position that they never got any moisture from dew or rain. Little wonder that they did not succeed with him. The two purple varieties referred to are *Dendrobium bigibbum* and *Dendrobium phalaenopsis*. They are obtainable at Cooktown and other far Northern ports very cheaply, and if given an easterly aspect, with shelter from our westerly winds, they do remarkably well. They can be grown on Frangipanni or other trees, but do equally well on hardwood blocks, provided a little peat or moss is attached firmly to them with copper wire. In fixing on the plants, see that they are firmly tied, otherwise the young roots may be injured should the plants sway about. During the warm weather, when the plants are growing, they should be watered daily. After they have bloomed (which is in the autumn) water should be gradually withheld, and

during the winter, which is their resting season, very little water should be given—just sufficient, in fact, to prevent shrivelling. Another lovely purple Orchid from the far North is *Dendrobium superbiens*, but this is not so plentiful nor so cheap as the other varieties. *Dendrobium undulatum* is fairly plentiful about the Cairns district, and does splendidly around Brisbane outside. It has a robust habit, the stems or pseudo-bulbs attaining a height of 8 or 10 ft. The flowers, which vary a lot, are in colour of various shades of a beautiful golden brown, and, as the name indicates, are very much twisted and crinkled. This variety throws a fine spray of flowers, bearing up to 20 on a flower spike, and is an excellent variety for ladies' sprays. It should be given plenty of moisture and sunshine.

If grown in a shady bush-house, it does not flower freely. *Dendrobium canaliculatum*, so named on account of the canal-shaped leaf, has a pseudo-bulb not unlike an onion. It is fairly plentiful in the Mackay district, where it grows on the ti-trees—particularly on the sea-shore—exposed to the sun. It has a lovely flower, white with a prettily-marked purple and orange lip, and has a very sweet perfume. This should be given a sunny position also. *Dendrobium Kingianum* is another favourite Orchid with beginners. It is obtainable on most of the mountains near Brisbane, but more particularly on the Main Range. It grows on moss-covered rocks, and during the spring months its beautiful pale-pink, dark-pink, and light-purple flowers are a sight worth beholding. It likes a shady position, and grows well in a basket with good drainage and a little peat or moss over its roots. *Dendrobium delicatum* is a fine variety, having a habit something like *Kingianum*, though the flowers are larger and open out better. It has beautiful large sprays of creamy white flowers, and possesses a very fragrant perfume. It is one of the finest of Queensland Orchids, and is getting very scarce. It grows on the Main Range, near Toowoomba. It likes a shady position, and should be given similar treatment to *Kingianum*.

Saxochilus cecillia is another little favourite with beginners. It has light-pink flowers, is very floriferous, and possesses a distinct and pleasant scent. It grows naturally on moss-covered rocks, but does equally well in cultivation on trees, or in pans containing plenty of broken crocks, with a layer of sphagnum or other moss over its roots. Writer sent home to England a clump of this variety, and though the flower is small it is much prized by the friend who received it.

All the foregoing are Epiphytes—*i.e.*, plants which grow upon trees—but some of the terrestrial kinds are worth inclusion in any collection.

Calanthe veratrifolia has pretty snow-white flowers, and makes a nice display in summer. A case of this variety was sent to England some years ago, and arrived in full bloom. It was sent to a flower show on the Continent, and was awarded a silver medal by the judges as an exhibit of exceptional merit. *Phaius grandifolius* and *Phaius Bernaysii* also do well, and have much bolder flowers than the *Calanthe* named. They require a shady position, and, having fleshy roots like the *Calanthes*, should be grown in a compost of fibrous peat, sand, and light loam, with plenty of good drainage.

The foregoing varieties do not embrace all that are available in Queensland, but are sufficient for this article. Should the beginner wish to add a few of the imported kinds, it can be done at very little cost, as the varieties I shall name are hardy, with practically very little risk of loss. *Dendrobium nobile* is one of the greatest favourites, and it does well in an ordinary bush-house. During the warm weather, when in a growing state, plenty of moisture is required. After the growths have matured, withhold water, and give only sufficient to prevent shrivelling. The winter is the resting season, and, unless the plants get a decided rest to harden their growths or pseudo-bulbs, few, if any, flowers will be given in the spring. Small plants can be imported from about 2s. 6d. each upwards. A plant of *Nobile* recently

flowered in Brisbane with 502 blooms, a record that it is possible has not been exceeded in any part of the world. I mention this to show how suitable our climate is for some Orchids, provided the proper treatment is given them.

Dendrobium Thrysiflorum is another hardy variety. It is not deciduous, however, so does not relish the drying in spring that *Nobile* can. It must not be allowed to shrivel or lose its leaves, otherwise a certain amount of natural strength in the plant will be lost. Its lovely tresses of white and orange flowers makes it a good variety for showing. *Dendrobium densiflorum* and *Farmeri* are two other fine varieties of the evergreen habit, which do remarkably well here under ordinary bush-house conditions. They, too, have beautiful tresses of orange and white and yellow respectively, and, like *Thrysiflorum*, are fine show varieties. *Dendrobium wardianum* possesses a truly noble flower of great substance. It is a waxy white, tipped with amethyst purple. The throat is ochre yellow, with two dark sanguinous blotches at the base. Like *Nobile*, is another variety which does remarkably well here. *Cattleya labiata* also does remarkably well here. It is one of the grandest of all Orchids, and hails from Brazil. There are many shades of this beautiful Orchid, from a blush rose to a deep rosy purple. It flowers in sheaths of 4 or 5 flowers to a pseudo-bulb, each flower measuring up to 8 in. across when fully expanded. The throat is usually marked with yellow, and the lip from a light shade to a very dark purple, and some varieties have a beautifully fringed and wavy lip. *Cattleya Trianae* resembles the foregoing somewhat, likewise *Cattleya Mossiae*, and some splendid specimens are to be seen among local growers. There are quite a number of other popular sorts in the *Cattleya* section well worth the attention of beginners, but I must be brief, so I shall pass them on this occasion, but cannot omit *Cattleya Harrisoni*, which throws sheaths with several flowers varying in shade from lilac to dark magenta, with a yellow and well-shaped lip. It is another hardy inexpensive sort, which thrives and blooms well here.

The slipper Orchids, which are called *Cypripediums*, possess a form peculiar and interesting by reason of the extraordinary shape and structure of the flowers. The upper or dorsal sepal is usually large, and the brightest feature of the flower, while the lip or labellum takes the form of a slipper-shaped bag. This family of Orchids is terrestrial in habit, and possesses no pseudo-bulbs, the flower spike being produced from the centre of the leaves, which in many species are beautifully mottled. *Cypripediums* require a compost of fibrous peat, sand, and leaf mould, and a moist, shady position, and do not need the rest necessary with some of the species named. *Cypripedium, Barbatum, Insigne, Callosum, Exul, Lawrenceanum, Spicerianum, Venustum,* and *Villosum* are all doing well in the local collections, so that fact, combined with their cheapness, warrants my recommending them as suitable for beginners. *Laelia anceps* is another fairly hardy Orchid that does splendidly when once established. It blooms in late autumn, when flowers are scarce. It comes from Mexico, and likes outside treatment. The flowers are variable, and are borne on tall spikes of 5 or 6 flowers of a rose colour, the lip being crimson purple, with yellow and red stripes.

There are, of course, hundreds of other Orchids which I could include in this article, but the foregoing is sufficient to enable beginners to get together a collection which will comprise many beautiful and hardy sorts that will well repay them for the little attention required in the way of watering and other attentions during their growing seasons.

Frequently one reads of fabulous prices being given for Orchids, and this more often leads the uninitiated to suppose that the extreme loveliness of the flowers borne by the plants purchased is the reason for the high value. In rare cases this may be so, but it is generally the rarity of the plant that commands the price, and it is possible a lover of flowers not versed in Orchids, if offered the choice of a 500-guinea plant or one sold usually for half a crown, might choose the latter as the more beautiful of the two.

RECORD PRICES FOR ORCHIDS.

In 1906, 1,150 guineas were paid at public auction in England for an *Odontoglossum crispium pittianum* Orchid plant consisting of three bulbs and a young break. The blossom is described as being most exquisite in colour and delicacy of form. At the same sale, 800 guineas were paid for an F. K. Sander, 470 guineas for an Abner Haßall, and 400 guineas for a Pittiæ, and in the previous year 875 guineas were paid for an *Odontoglossum*.

We have, in Queensland, several florists who have been very successful in growing Orchids, notably Mr. Bartels, of Clayfield. From the foregoing, it would appear that a fortune awaits the grower who can produce certain varieties, but, probably, also, it would require a small fortune to obtain the bulbs wherewith to build up the fortune *in posse*.

In purchasing the imported plants be guided by a friend who has had some experience, or you may import some varieties that require a cool-house treatment, and consequently will not stand our summer temperature. Other varieties will not live in a temperature lower than 40 deg. unless protected by a hothouse. If not inclined to invest in the latter, it would be better to avoid disappointment by leaving them out of your collection meanwhile. Get your little collection together, observe their habits, and give the plants the prescribed treatment. If they are slow in starting, change their position, and you may get a pleasant surprise. A poultry farmer would meet with little success if he bundled his Buff Orpington fowls into the duckpond with the Indian Runners, and it is the horse sense that would avoid such a silly mistake that will keep an enthusiastic and interested Orchid-grower from failing with his Orchid treasures.—E. J. BEARD, in the "Queensland Agricultural Journal."

Mr. Beard does not mention *Cypripedium minos*, Young's variety, a very beautiful hybrid between *C. Spicerianum* and *C. Arthurianum* (*Fairricanum* × *insigne*). This variety was raised, says the "Gardeners' Chronicle," a good many years ago by the late Reginald Young, of Liverpool, and has been shown on several occasions, but failed to get the highest award, although many experts deemed it worthy. Messrs. McBean showed the plant at its best, and at last succeeded in obtaining a first-class certificate. The dorsal sepal is white, tinged and veined with purplish-rose from a small green base. The petals and lip are of a shade of honey-yellow with red-brown. The illustration is also taken from the "Gardeners' Chronicle."

CARE OF ORCHIDS.

It cannot be too strongly impressed upon the intending Orchid-grower that the plants require abundance of fresh air, and all the ventilation possible. Perhaps the most important point of all in the cultivation of these choice plants is—absolute cleanliness. In their native homes, upon the lofty trees of humid forests, very little dust can ever find its way to them, whereas, in our State, wherever they are grown either in bush-houses or on trees in the garden, or on verandas, they cannot remain many days before they become loaded with dust and dirt. This, as it accumulates, must be scrupulously removed. It is a work of patience, but it must be done, and no plan answers better for the purpose than to use a sponge and soap and tepid water, washing carefully each leaf of each several plant, both upper and lower surfaces, changing the water frequently as it becomes dirty. I need hardly observe that the cleansing work must be done with a light hand, and the plants subjected to no rough usage.

VARIETIES.

To enumerate the hundreds of species of the many genera of known Orchids would be a task quite beyond what is the limited scope of this dissertation on Orchid-growing. The genus *Dendrobium* alone is said to contain nearly 400 species. *Epidendrum* comprises over 300 species, confined almost



OLD KANAKA HUTS AND FIELD OF CASSAVA AT FARNBRO', CHILDERS.

Plate XLII.



CYPRIPEDIUM MINOS—YOUNG'S VARIETY.

exclusively to South America. *Coelogyne* is a genus of Orchids entirely Eastern, and most are natives of the hills of India. *Broughtonia sanguinea* is a native of Jamaica with blood-red flowers. *Loelia* is another South American genus, containing some of the most superb of the Orchids. Amongst these are:—*L. anceps*; *L. majalis*; *L. purpurata*; *L. superbiens*; *L. acuminata*, and *L. autumnalis*.

Cattleya is a genus closely allied to *Loelia*, and is confined principally to Central America and Brazil. The flowers they bear are accounted to be amongst the largest in the order, some being as much as 7 in. across, from tip to tip of the petals. The finest of all is *Cattleya Warscewiczii*. Next to it stand *C. Mossiae*; *C. labiata*; *C. crispa*; *C. Skinnerii*, and *C. Aclandiae*.

Brassavola is a genus of Orchids of Tropical America remarkable for the fragrance of their flowers, with long-tailed petals.

PHAIUS.

This is one of the terrestrial Orchids, natives of the East, with yellow or dull-orange flowers. *Thunia olim Phaius*: Grows well in the open ground. *Arundina*: A terrestrial Orchid, native of Nepaul, nearly allied to *Bletia*, a slender reed-like plant, bearing thin purple flowers. *Bletia*: A terrestrial Orchid, native of China, bears abundance of bright pink flowers. *B. verecunda* throws up long flowering stems 3 ft. high, displaying their flowers in full beauty for more than two months. *Spathoglottis* much resembles the foregoing. *Cyartopera* is another terrestrial Orchid of India. Its large flowers are golden yellow; the spike of blossom appears before the leaves.

VANDA.

All the species of Vanda are very beautiful, especially *V. gigantea*, *V. teres*, *V. cerulea*, *V. Cathcarti*, and some others.

RHIZANTHERA.

R. coccinea: Chinese Air-plant.—Thrives vigorously and blossoms to perfection in a hot climate when bound to an upright log, and exposed throughout the year to the full power of the sun. The flowers are narrow, with bright coral-red petals, of spider-like form, produced in immense profusion.

R. arachnites.—This Orchid is also called *R. moschifera*. It bears sprays of about 12 flowers, much like huge spiders, 5 in. across, of a lemon colour with great purple spots, emitting a delicate scent of musk; considered one of the most remarkable of all the Orchids. Requires full exposure to the sun.

PHALAENOPSIS.

P. amabilis.—Queen of the Orchids—Indian Butterfly Plant. A native of Amboyna; flowers very large, milk-white, leathery; lip marked with purple lines; resembling a butterfly with expanded wings, lasting unimpaired for several weeks. This most choice and magnificent plant is always grown fastened with moss and copper wire upon a log. It may be easily propagated, I am told, by binding a piece of moss round one of the joints of the flowering stalks, which will emit roots, and may then be removed and attached in the usual way to another log.

Other varieties of this species are:—*P. grandiflora*; *P. Schilleriana*; *P. Cornu-cervi*; *P. Lowii*; *P. Parishii*; *P. rosea*; *P. Manneii*; *P. Schumannii*.

The great point to obtain success in the cultivation of these plants, is to render the leaves healthy, by keeping them as well exposed to the light as possible.

SACCOLABIUM.

The flowers are generally small but borne very numerously in large dense clusters of a plume-like form, most exquisite in colour and delicate in character.

S. giganteum.—A magnificent plant from Burmah, with broad, lightest green leaves. Flowers are very fragrant, white, spotted with violet.

S. guttatum (syn. *S. retusum*).—Bears spikes of bloom a foot or more long of small white flowers, spotted with rose. Others are:—*S. micranthum*; *S. miniatum*; *S. ampullaceum*; *S. Blumei*; *S. denticulatum*.

AERIDES.

Flowers resemble in general appearance those of Saccolabium. There is probably no genus among Orchids, the species of which are more generally ornamental—no species not worth growing. Even when not in bloom, the different species, all similar in habit, are all good-looking objects, from the pleasing disposition of their substantial-looking foliage.

A. affine.—Native of Assam; bears rose-coloured flowers. *A. odoratum*.—Assam; bears pretty trusses of bloom with small white flowers, tinted and spotted with pink, having the form of a curved horn, and diffusing an exquisite lemon-like fragrance.

Of great beauty are also *A. Lobbii*; *A. Fieldingii*; *A. quinquevulnerum*; *A. virens*; *A. Lindleyanum*; *A. roseum*; and *A. suavissimum*.

ONCYDIUM.

A genus comprising more than 200 species, confined entirely to tropical America. Many are natives of the mountains and require no very high temperature. Species well worth growing are:—*O. ampliatum*; *O. luridum*; *O. crispum*; *O. bicallosum*; *O. lanceanum*, accounted the most beautiful of all, and *O. papilio*, the famous Butterfly plant.

STANHOPEA.

Plants are remarkable for the way they thrust their spikes of flowers through the bottom of the baskets in which they are suspended. *S. martiana* and *S. tigrina* thrive well in warm countries.

A LOST ORCHID REDISCOVERED.

In 1905 the "Lost Orchid," *Cypripedium fairrieanum*, was rediscovered by an Englishman, and he, with Mr. S. P. Chatterji, the well-known florist and nurseryman of Calcutta, have the secret of its natural habitat between them. They had, in the year mentioned, a fine stock of the plants, and became entitled to the reward of £2,000 (says "Indian Gardening") offered by a certain London firm of plant merchants to anyone who would rediscover the "Lost Orchid." The locality where this Orchid was found remains a profound secret, at least, such was the statement made at the time, but, suffice it to say, it was *not* found in the Garo Hills, its supposed natural habitat. There was no doubt at all as to the identity of the plant, as it was submitted to Dr. Prain, Superintendent of the Royal Botanic Gardens, Calcutta. This was probably the most important and sensational announcement that the horticultural and botanical world had received for many years. The plant was lost to the world in 1876, and, until its rediscovery, may be said to have been practically extinct in Europe.

FIG. XLIII.

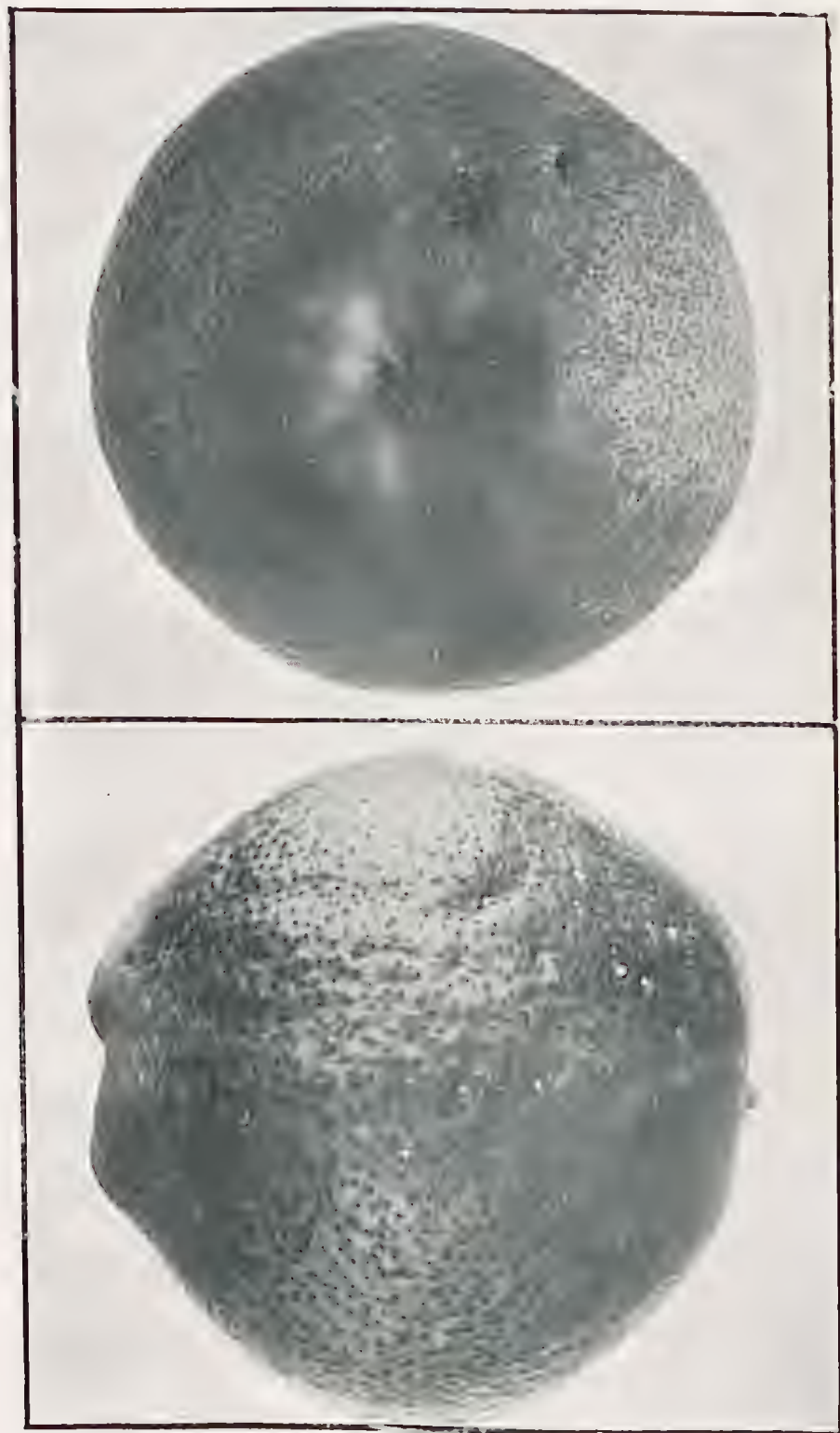

CLIFFORD'S HYBRID PEAR—WEIGHT, 15 OUNCES.
GROWN BY J. ORRILL, BRISBANE DISTRICT, near Mount Gravatt.

The Orchard.

A FINE PEAR TREE.

There is an impression amongst many people that such fruits as pears and apples can only be grown successfully on the table-land, in the neighbourhood of Toowoomba, Warwick, Stanthorpe, &c. That this is a fallacy is well shown by the splendid samples of pears grown by Mr. J. Obrist, an orchardist living some 5 miles beyond Mount Gravatt, near the Broadwater. We saw one particular pear tree in this orchard, fruiting heavily, and Mr. Obrist last month brought a sample to this office of Clifford's hybrid pear, here illustrated. Each fruit weighed 15 oz., was well-shaped, and of excellent flavour. There was a good crop on the tree, but much was damaged by the opossums in spite of all care. Mr. Obrist, every year, places thousands of grafted trees of various kinds on the market, particularly citrus trees, persimmons, custard apples, peaches, and mangoes. If he were to do the same with his pear trees, he would doubtless be equally successful. We might bring to the recollection of our older readers, that splendid apples were grown by the first Anglican Bishop of Brisbane, Dr. Tufnell, at Bishopsbourne. There the soil is exceedingly poor, resting on a substratum of shale, yet the apples we saw there could not be beaten even at Stanthorpe.

Statistics.

COMMONWEALTH METEOROLOGY. RAINFALL OF QUEENSLAND.

TABLE SHOWING THE TOTAL RAINFALL FOR EACH MONTH OF THE YEAR IN THE AGRICULTURAL DISTRICTS OF QUEENSLAND.

| STATIONS. | 1908. | | | | | | | | | 1909. | | | |
|--------------------------|--------|-------|-------|-------|------|-------|------|------|------|-------|-------|-------|--------|
| | April. | May. | June. | July. | Aug. | Sept. | Oct. | Nov. | Dec. | Jan. | Feb. | Mar. | April. |
| <i>North.</i> | | | | | | | | | | | | | |
| Bowen | 3 73 | 0 99 | 0 45 | 0 88 | 0 51 | 0 96 | 2 47 | 0 42 | 0 42 | 15 45 | 4 52 | 1 06 | 1 1 |
| Oairns | 5 99 | 3 05 | 0 59 | 3 70 | 2 12 | 0 74 | 3 07 | 1 60 | 1 41 | 32 05 | 5 25 | 21 03 | 14 |
| Geraldton | 14 23 | 18 52 | 2 64 | 8 11 | 3 66 | 2 81 | 6 93 | 3 80 | 1 69 | 47 92 | 10 29 | 37 31 | 23 51 |
| Gindie State Farm | 0 02 | 0 112 | ... | 0 40 | 1 27 | ... | ... | ... | ... | ... | ... | ... | ... |
| Herberton | 1 40 | 0 38 | 0 31 | 2 36 | Nil | 0 51 | 1 27 | 0 61 | 0 78 | 12 41 | 2 28 | 3 52 | 0 70 |
| Hughenden | 0 30 | Nil | 0 05 | 0 68 | Nil | Nil | 1 67 | 1 94 | 1 05 | 7 55 | 1 55 | 2 86 | ... |
| Kamerunga State Nurs. | 4 60 | 3 363 | 0 76 | 4 85 | 1 58 | ... | 3 64 | 1 63 | ... | ... | 3 52 | ... | 4 95 |
| Mackay | 14 82 | 3 25 | 1 29 | 1 65 | 0 71 | 2 27 | 1 80 | 2 57 | 0 02 | 15 00 | 1 36 | 0 00 | 2 59 |
| Rockhampton | 2 62 | 0 85 | 0 10 | 1 08 | 0 81 | 0 20 | 2 14 | 2 47 | 1 37 | 9 01 | 2 01 | 1 68 | 1 21 |
| Townsville | 0 38 | 2 22 | Nil | 1 70 | 0 27 | 0 28 | 1 58 | 1 26 | 0 07 | 6 94 | 1 70 | 7 01 | 1 28 |
| <i>South.</i> | | | | | | | | | | | | | |
| Biggenden State Farm | 2 97 | 0 74 | 0 43 | 0 49 | 2 33 | 1 39 | 1 80 | 2 12 | 3 66 | 7 37 | 2 68 | 2 45 | 2 00 |
| Brisbane | 2 45 | 2 40 | 0 17 | 0 77 | 2 83 | 0 67 | 1 77 | 2 25 | 1 28 | 1 99 | 2 72 | 2 65 | 4 67 |
| Bundaberg | 4 13 | 0 67 | 0 39 | 0 75 | 1 56 | 1 10 | 2 39 | 0 73 | 3 34 | 6 52 | 3 70 | 5 06 | 1 54 |
| Dalby | 0 11 | 0 37 | 0 63 | 0 14 | 1 80 | 1 13 | 2 55 | 3 63 | 1 56 | 1 46 | 3 55 | 0 59 | 1 60 |
| Esk | 2 83 | 1 07 | 0 23 | 0 46 | 2 75 | 2 16 | 1 29 | 5 99 | 3 | 2 64 | 3 21 | 3 27 | 5 03 |
| Gatton Agric. College | ... | 0 10 | 0 16 | 0 6 | 2 71 | 1 84 | 1 93 | 5 71 | 1 13 | 1 94 | 5 00 | 3 18 | 3 82 |
| Gympie | 1 87 | 2 00 | 0 38 | 1 16 | 2 87 | 1 37 | 2 40 | 2 58 | 3 97 | 3 86 | 3 77 | 3 41 | 2 34 |
| Ipswich | 2 71 | 1 14 | 0 12 | 0 47 | 3 23 | 1 19 | 1 48 | 5 09 | 1 03 | 1 37 | 1 95 | 2 66 | 4 56 |
| Maryborough | 2 52 | 1 05 | 0 46 | 0 81 | 1 98 | 1 05 | 1 84 | 1 92 | 1 64 | 8 36 | 7 11 | 2 28 | 2 44 |
| Roma | 0 22 | Nil | 0 55 | 0 63 | 1 38 | 1 12 | 2 15 | 2 79 | 1 68 | 5 19 | 4 85 | 4 18 | 1 91 |
| Roma State Farm | ... | ... | ... | 1 27 | 0 73 | ... | ... | ... | ... | ... | ... | ... | ... |
| Tewantin | 7 59 | 8 66 | 0 75 | 1 97 | 2 70 | 2 18 | 2 30 | 7 50 | 4 12 | 6 44 | 3 31 | 4 34 | 9 37 |
| Warwick | 1 40 | 0 15 | 0 80 | 1 24 | 2 99 | 1 96 | 5 28 | 2 02 | 0 87 | 0 82 | 1 39 | 2 21 | ... |
| Westbrook State Farm | 1 49 | 0 0 5 | ... | 0 49 | 1 97 | ... | ... | 2 05 | ... | ... | 2 61 | 1 43 | ... |
| Yandina | 5 45 | 4 59 | 0 58 | 2 64 | 2 18 | 1 50 | 3 10 | 6 03 | 2 75 | 6 69 | 6 42 | 3 71 | 5 25 |

NOTE.—The rainfall data in this table are compiled from telegraphic reports, and must be considered as approximate only.

GEORGE G. BOND,
Divisional Officer.

Tropical Industries.

CASSAVA.

Under the name of "American potato" we lately received a specimen of the cassava plant and tuber from a correspondent who had never seen a cassava plant before. He found that the tubers were similar in taste to a sweet potato. In view of this, it is well to warn those who do not know the plant, of its poisonous qualities.

In the tropical regions of South America and in the West Indies cassava forms a valuable article of diet under the name of manioc or manihot. Of this plant there are two varieties—the sweet and the bitter, although some botanists maintain that the sweet variety is merely a sport of the bitter. In the tropical countries named the bitter cassava is an important cultural plant, not only as producing an article of native food in the shape of cassava flour, but also the well-known tapioca of commerce.

The plant itself belongs to the semi-wooden shrubs. The stem is full of pith, and attains a height of from 5 to 6 ft., and under favourable conditions of soil and climate even as much as 8 ft. The leaves are of a bluish-green, divided somewhat similarly to those of the papaw. The value of the plant lies in its large tubers, which attain a weight on an average of 8 or 10 lb., with a length of from 18 in. to 2 ft. These tubers are brown or dark-yellow, and contain a quantity of highly poisonous juice.

The poison, however, is, fortunately, very volatile, consisting of hydrocyanic (prussic) acid. In the bitter variety the poison is distributed throughout the root, while in the sweet cassava the poisonous principle is chiefly in the rind. It is on record that on 50 lb. of the juice being distilled, 3 oz. of distillate were obtained, and 35 drops of this killed a man at once. Bitter cassava root sliced and dried yielded from the root 0.09 per cent., and from the rind, 0.035 per cent. of hydrocyanic acid. The glucoside, by the decomposition of which the hydrocyanic acid arose, was determined to be identical with phaseolunatin from Lima bean seeds.

In New Guinea, a few years ago, a Mr. English, a sisal planter, planted an area of cassava, intending it for native food. Unfortunately, about twenty of his boys partook of the cassava tubers imperfectly cooked, with the result that he with difficulty saved the lives of nineteen, one boy actually dying.

The bitter cassava can be distinguished from the sweet by the leaves. In the former the leaves have seven divisions, the latter only five, the root also of the sweet variety is smaller and reddish in colour, and does not contain so much farina as the bitter, hence the latter is almost exclusively cultivated in countries where cassava flour is a principal article of native diet.

CULTIVATION.

The planting and cultivation of the cassava plant is as simple as for arrowroot, but it should only be grown near the coast, where atmospheric moisture is found even in the absence of rain. It is only during the first two months after planting that a good rainfall is necessary; after that the plant will thrive without any further showers.

The soil must be rich, well-drained, and deeply worked. Wet ground must, above all, be avoided, since too much moisture causes the roots to rot. The plant is reproduced in the same way as sugar-cane—by cuttings from the stem. Only the tough wood of the full-grown stems should be used for cuttings. These, which should be about 1 ft. in length, are laid in the furrow

and covered as is done with sugar-cane cuttings. On very rich land the rows should be from $3\frac{1}{2}$ to 4 ft. apart. So quickly do the cuttings grow that after two months the shoots will attain a height of 1 ft., and six, or at most eight weeks later, the plants will have taken such possession of the ground as to prevent the growth of weeds, and thus further cultivation becomes unnecessary. In about eight months after planting the tubers are ready for digging; but they will take no harm if left in the ground for a year and taken up as required.

The resulting crop on rich land or with good fertilisers will amount to from 6 to 8 tons per acre, and the digging can be done for about 2s. per ton.

The following estimate of cost of producing a crop and profit is furnished by a cassava planter in Florida:—

| | <i>s.</i> | <i>d.</i> |
|--|-----------|----------------|
| Ploughing per acre | 6 | 0 |
| Harrowing per acre | 1 | $5\frac{1}{2}$ |
| Cuttings planted 4 feet x 4 feet | 6 | 11 |
| Planting per acre | 4 | 0 |
| Six cultivations | 8 | 5 |
| Four hoeings | 16 | 0 |
| Fertiliser (if required) 350 lb. per acre, at £5 per ton ... | 16 | 0 |
| Digging and hauling (say 1 mile) | 5 | 0 |
| Total | £3 | 3 9½ |

Value per ton, £1. To pay expenses a crop of 4 tons is required. Therefore, on an 8-ton crop, the net return per acre is about £4 16s. 2½d.

HARVESTING.

The stems are first cut above the ground, when the tubers are drawn out. Any which break off are afterwards taken up with a hoe or ploughed out, or the whole crop may be ploughed out. The tubers are then carted to a shed, where they are separated from the stems, these latter being preserved for setts for the next planting.

Cassava being a very exhausting crop, it should not be planted more than two or three times in succession on the same land.

PREPARATION OF THE FARINA.

The process in British Guiana is as follows:—

The root is rasped on large tin or wooden grates fixed on benches. A sufficient quantity having been rasped for one time—for any surplus would ferment and spoil—it is put into long, circular baskets of plaited rushes, about 10 ft. long and 9 in. in diameter, called “mangueras.” These are hung up with weights attached to the ends, which draw the plaited work tight together, diminishing its capacity, and squeezing out the juice. When all the fluid is extracted, the mangueras are emptied of their contents on to raw hides laid in the sun, where the coarse flour soon dries. It is then baked on smooth plates made of dry clay, with a slow fire beneath. This is the most difficult part of the process. The coarse flour is laid perfectly dry on the hot plates, where it is spread out in a round and very thin layer, nearly the size of the plate it is laid on. The flour is kept in constant motion until the heat has, with gentle pressure added, united it into a cake, without altering the colour or scorching it. This is the native bread, and it is very nourishing, and will melt to a jelly in a liquid, but it is dangerous if eaten in any quantity when dry, as it swells, on being moistened to many times its original bulk. The expressed juice deposits, after standing for some time, a fine white starch which is not to be distinguished from that prepared from arrowroot.

The cassava farina constitutes the tapioca of commerce when heated on hot plates, which causes the grains to swell, many of them bursting, and the whole agglomerating into irregular masses or lumps. The finest are sold as

tapioca, the intermediate sample being used for starch. There are large plants for the making of tapioca, but much of the tapioca of commerce is produced with simple appliances such as here shown.

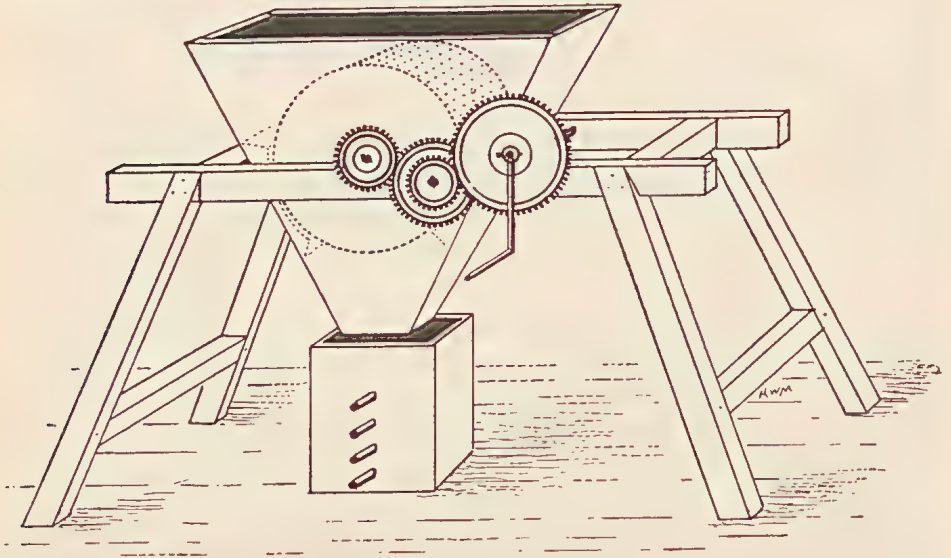

CASSAVA STARCH HAND MILL.

The roots of the cassava are well washed and peeled to get rid of as much of the poisonous principle as possible. If they are left for a couple of days in water, the skin comes away easily. They are then passed through the grating machine, continuous streams of water being poured upon the grated mass to separate the starch from the fibre. When the starch has settled in the vats, the water is gradually drained off through a series of taps, one above the other. More water is added and the starch well stirred, and again allowed to settle, the water being drained off as before. This process is continued until the starch is perfectly white. When the surface is dry, it is cut out in lumps, which must be thoroughly dried on airy shelves before they are placed on horizontal tin plates, beneath which is a hot-air pipe in which a particularly gentle heat is maintained. In Europe, tapioca is usually sold in the form of flakes, which are made by placing the lumps of starch, in a nearly dry state, in deep pans, where they are subjected to strong heat, and are continually stirred about until they have acquired the desired form.

In the Straits Settlements "Pearl Tapioca" is made in the following manner:—

The dried masses of starch are placed in a hand mill, where they are reduced to the size of No. 4 shot. From the roof of the factory hangs a coarse cloth, like a veranda hanging mat or blind, kept spread out by a crosspiece of wood, so that it looks like a canvas boat. The cloth is filled with the shot-like starch, and it is then swung backwards and forwards by two men. Under this treatment the grains are ground into perfectly round little balls, which require to be once more warmed for half-an-hour by gentle heat in a pan, when the process is complete. In fine weather they are often exposed for half a day to the sun's heat.

In the cassava plant we have a raw material which yields a starch of the highest purity, possessing all the characteristics of the maize product, the cost of production being one-fifth that of maize. In experiments made in Florida with fresh roots, the average percentage of starch was found to be 24.75, and with Jamaica roots 26.23; 4 per cent. of cane sugar was also

recovered from the liquor. Compared with maize and potatoes, upon which practically the whole world depends for its supply of starch, the average yield of starch is as follows:—Maize, 53; potatoes, 18; cassava, 25 per cent. An acre of ground yields 40 bushels of maize (on an average), which, in turn, yield 1,200 lb. of starch, whilst the same ground will yield 10 tons of cassava, yielding 6,720 lb. of glucose and 5,000 lb. of starch; and it is possible to reach a much greater amount. In Queensland 12 to 14 tons of casava roots could be raised on an acre of our rich, virgin, northern scrub lands.

The only cassava starch factory in the world is in Florida, U.S.A., and there cassava costs $\frac{1}{4}$ d. per lb. in the unmanufactured state.

A plant has been devised by means of which the whole 25 per cent. of dry starch can be obtained, and this plant can be worked 25 per cent. cheaper than the potato starch plant, the process being perfectly automatic and continuous. The plant will work up 100 tons of roots per day of ten hours. The entire process occupies three days, when the starch is ready for market, while maize, under the most favourable conditions, requires from twelve to fourteen days.

As regards the process of manufacture of the starch, it is so similar to that adopted in Queensland for the production of arrowroot starch that it need not here be described. An account of the process, however, will be found in the issue of the "Queensland Agricultural Journal" for May, 1903.

It is unquestionably true that as a food for farm stock, cassava comes nearer supplying a perfect ration than any other concentrated food produced on the farm. Experiments in feeding stock have proved it to be the best and cheapest ration which can be used for fattening purposes. The most astonishing fact, however, is the great difference demonstrated between the cost and the result of feeding corn and feeding cassava, the difference being almost two-thirds in favour of the latter.

In conclusion, the cassava plant will thrive under the most diverse conditions of climate (frost excepted), on dry plains, on rocky hillsides, as well as on the humid plains and hills wherever the soil is friable or gravelly. The tubers can be dried and stored to keep for some time, thereby reducing the weight for transport to a distant factory, and thus the factory can be kept going most of the year.

MANILA HEMP MACHINE.

The extraction of the fibre of the *Musa textilis*, otherwise known as Manila hemp, has hitherto been effected practically by hand labour, although the native workmen employ a primitive kind of implement to extract the fibre, which yet entails severe manual labour. Numerous inventors have taxed their ingenuity to produce a machine capable of extracting the fibre with the same ease and speed as in the case of flax and sisal hemp, but hitherto with poor results. In conversation with a gentleman who has spent many years in the Philippines, it was elicited that no less than forty inventors had patented machines for this purpose, and companies were formed who had paid as much as 100,000 dollars for the patent rights of some of these inventors.

It seems, however, as if the problem of a stripping machine has at last been solved by an Australian, a native of West Maitland, Mr. J. S. Gillies, a nephew of Mr. J. Gillies, M.L.A. Young Mr. Gillies worked at his idea for seven years. Twice he exhausted his little capital, and offered to sell a half-interest in his machine for 500 pesos, or about £50; but, fortunately, he was unable to find a buyer, but a company was formed for the purpose of

manufacturing and placing the machines on the market. The "Far Eastern Review" contains the following account of Mr. Gillies' invention:—

"No one who has seen the Philippine hemp machine, manufactured by the Philippine Hemp Machine Company, in operation, will deny that it is destined to revolutionise the hemp industry. It is bound to do for the Philippines what the cotton-gin did for the South. It is, in a word, one of the most marvellous pieces of machinery ever built, and is, at the same time, simplicity itself, and in spite of the oft-proclaimed statement that the ingenuity of man would never be able to build a machine that would strip hemp as clean and quickly as it is done by hand, Mr. J. S. Gillies, to whom the credit for the patent is due, was able to figure out a machine that not only strips hemp a hundredfold more rapidly than it could possibly be done by hand, but produces a cleaner and stronger fibre.

"It makes no difference how long a strand of hemp stripped by the machine may be, it is as strong at one end as at the other, and, what is more, there is absolutely no waste whatever, every inch of the fibre being as clean and useful as only certain parts of hand-stripped hemp can possibly be; and in fact, marvellous as it may seem, all the weak strands are eliminated. The tensile strength of hemp stripped by this machine shows, by actual tests made by the Bureau of Science of the Philippines Government, to be from 80 to 100 per cent. above that of hand-stripped hemp. This is a wonderful thing in itself, and if the machine did nothing else it would still sustain the claim of being one of the greatest inventions of recent years. But it does still more. For instance, the hemp comes from the machine absolutely clean and with no pulp adhering to it. This means that hemp stripped by the machine will not contain tangles and snarls, which always result in a loss to the manufacturers who make up the raw product. The juice of the hemp plant is totally extracted. This means that all sugar and tannic acid is removed, which minimises the chance of decomposition, and guarantees a bright, glossy, snow-white product. There is another advantage to this feature. By coming from the machine in almost a perfectly dry state, it is possible to bale the product the day it is stripped, something undreamed of with hand-stripped hemp.

"The above is a brief summary of what the machine is capable of doing. Now for a few words about the machine itself. It weighs about 650 lb., and it is possible to transport it easily from one part of a hemp plantation to another. One of the greatest drawbacks to many hemp machines of any ability at all has been their lack of portableness. With this machine a small petroleum motor can be attached, which will enable it to be operated anywhere and under the most adverse conditions. It has been demonstrated beyond a question of doubt that the machine is capable of performing the work of 100 operators doing the same work by hand.

"It has been a long, and, one might add, a discouraging task to complete this wonderful machine. It is the outcome of the idea of Mr. J. S. Gillies, who worked at it for more than five years. As two heads are always better than one, when Mr. M. A. Clarke, the president of the company that owns the patents, and is now engaged in manufacturing the machines, took hold, he called in Mr. R. A. Wilson, a mechanical engineer, who assisted Mr. Gillies to perfect the machine in many details.

"It is estimated that the hemp crop will exceed 1,000,000 bales in the Philippines this season, which would require a large number of machines. In fact, it would be impossible to strip this amount of hemp entirely by hand. The Philippines Hemp Machine Company, the owners of the patents, have recently sent Mr. R. A. Wilson to the United States to superintend the construction of a large number of machines, which, in due season, will be stripping hemp in all of the fibre-growing districts of the Philippines.

"The original capital of the company was 50,000 pesos, but, owing to the fact that the machine has developed a capacity far beyond the dream of its inventor when he began the construction of the original model, which will mean a great demand for the machines, the company has decided to increase its capital stock to 1,000,000 pesos. It is the intention of the company to sell 50,000 pesos worth of the shares—valued at 100 pesos each—at the present time, and on 4th December a circular letter was sent to each of the shareholders informing them of this decision, and advising them that present shareholders would be given preference over outsiders in the allotment of the new shares.

"The officers of the company are:—M. A. Clarke, president; J. S. Gillies, vice-president; A. W. Beam, secretary; and A. R. Wilson, mechanical engineer. The offices are in Manila.

"The greatest credit is due to the keen perception and hustling qualities of Mr. Clarke for making it possible to have this machine perfected. From the first time it was shown to him in the drawings he saw what it meant for the Philippines, and he lent every assistance possible to the inventor and others interested to bring it to its present state of perfection. It means a revolution in the hemp industry the world over."

NOTES FOR FARMERS ON THE FIBRE INDUSTRY.

We have frequently suggested to farmers who have portions of stony land on their farms where no cultivation can be done, and which produce nothing but weeds and brambles, to plant up such spots with Sisal or Fourcroya. If several farmers would do this, the combined area would enable them in the course of four or five years to set up a central mill, which would enable them to realise a handsome profit from land, which let alone, as it now is, not only gives no return, but acts as a nursery for noxious weeds.

Mr. Leonard Cutt, of Tongaat, Natal, whose report on the fibre industry in Mauritius last year created great interest amongst the farmers not only of Natal but of other parts of Africa, says that it was in consequence of that report that three gentlemen in that colony imported over half a millian sisal bulbils to start the industry on a large scale. We believe that these bulbils were purchased from a sisal-grower in Queensland, and were shipped a few months ago to Mombasa from Brisbane. Mr. Cutt has again written on the subject, and amongst other things he says:—

What a field there is in the growth of wild aloes in this manner, and without taking up land on which something else can be grown.

When one contemplates the potentialities of fibre culture in this way [that is, without any cultivation.—Ed. "Q.A.J."], one wonders that the idea does not seize upon the mind of the people, but to dip in Jordan is, of course, too absurdly simple.

Hundreds of thousands of acres of practically desert country in the valleys of the Tugela, Umvoti, Bushman's, and Blue Krantz Rivers might be utilised, and Zululand could spare as many acres more and not miss them.

If Mauritius, a small island, only 34 miles by 22 miles, containing only 456,320 acres, can on its waste land produce £100,000 worth of fibre, as it has done, although the value of the output for the last four years was only £45,000 a year, what could Natal produce on its 16,000,000 acres, exclusive of Zululand?

A great industry is ready to our hand, and one not requiring a large outlay. Let us put out our hands and take what is so obviously within our reach.—"Natal Agricultural Journal," Vol. XI., No. 12, December, 1908.

Botany.

CONTRIBUTIONS TO THE FLORA OF QUEENSLAND.

By F. MANSON BAILEY, F.L.S., Colonial Botanist.

Order CAPPARIDÆ.

CAPPARIS, Linn.

C. canescens, *Banks.* Add to the description, page 59 of Ql. Fl. Peduncles 2 to 3 in. long, stout; stipes 2 to 3 in. long, stout; fruit about 2 in. long, $1\frac{1}{2}$ in. diam., shortly tapering at the base, and more or less umbolate at the apex, and more or less prominently ribbed in the lower half and very slightly tuberculate. Seeds orbicular-ovate, about 5 lines diam., smooth.

Var. *glauca*, *Benth.* Add fruit almost globular, $1\frac{1}{2}$ to 2 in. diam., irregularly covered with thick flattened tubercles, which sometimes form irregular thick wings reaching from top to bottom of the fruit. Seeds few, large.

Order EUPHORBIACEÆ.

EXCÆCARIA, Linn.

E. parvifolia, *Muell. Arg.* Add to description, page 1457 of Ql. Fl. Female flowers sessile, two or more together on very short angular bractiferous peduncles; bracts orbicular, margins hairy. Ovary $\frac{1}{2}$ line long, broader than long, 2 or 3-celled; styles 2 or 3 recurved; nearly or quite free. Capsule smooth, 3 lines diam., 2 or 3-celled, bearing the persistent styles. Seeds smooth.

Order URTICACEÆ.

FICUS, Linn.

F. eugenioides, var. *puberula*, *Benth.* Fl. Austr. VI., 167. Specimens of this plant have been received from Dr. T. L. Bancroft, Stannary Hills.

Order GRAMINEÆ.

DIPLACHNE, Beauv.

D. parviflora, *Benth.* Fl. Austr. VII., 620. A glabrous erect grass of 2 or 3 ft. Leaves convolute, with long rather loose sheaths, the ligula jagged. Panicle narrow, dense, varying from 3 to 10 in., with long erect simple branches. Spikelets very numerous, sessile or nearly so, 3 to 4 lines long, very narrow, 5 to 7-flowered. Outer glumes about $1\frac{1}{2}$ lines long. Flowering glumes shorter, glabrous on the back, the margins ciliate, the lateral nerves scarcely distinct, the keel produced into a short point, the lateral hyaline lobes adnate to it almost to the top. *Triodia parviflora*, R. Br. Prod.; *Festuca Brownii*, F. v. M. Fragm. VIII, 129. *Benth., l.c.*

Hab: Arnhem S. Bay, *R. Br.*, and North-west Coast, *Hughan*, Roma, Queensland, *C. T. White*, April, 1909.

Animal Pathology.

CONTAGIOUS ABORTION.

By SYDNEY DODD, F.R.C.V.S., Principal Veterinary Surgeon and Bacteriologist.

This condition is known by other names such as slipping or slinking the calf, picking, warping, and miscarriage. Technically speaking, a distinction is made between abortion and premature birth, but for all practical purposes it may be broadly stated that abortion in relation to stock refers to the expulsion of the foetus or young immature animal from the womb before its time, and usually before it is capable of a separate existence.

All animals are liable to be affected with that form of abortion known as "contagious," including cattle, sheep, horses, and goats; but it is amongst dairy cows and heifers that it occurs most frequently, and is more serious from a financial point of view.

Single animals at any period may cast their young from various causes, such as general debility, fright, worry, strain, indigestion, bloating, blows, early breeding, feeding on grasses infested with ergot or smut, acute fever, or contagious diseases, such as tick fever, or pleuro-pneumonia; but under the head of "contagious" are classed those abortions which usually affect many animals in a herd, stud, or flock, and the existence of which usually appears to depend upon some former case.

Contagious abortion is a disease widely spread throughout the world, and in Australia, generally, considerable pecuniary losses are experienced by owners of dairy herds in various places by its effects. In Queensland there is evidence that it exists in various parts of the State, although at present not to any alarming extent, but its presence has often not been recognised by the owners of the herds concerned. The condition of affairs calls for action on the part of the owners of dairy herds, not only of those whose herds are affected, but of those whose herds are free from the disease: the former, in order to eradicate it from their animals; and the latter, in order to prevent its introduction. Action is needed, because the disease can be prevented and extirpated by perseverance and vigilance, and now is the time to take the necessary measures before the disease has obtained a firm foothold amongst the dairy herds in the State.

Contagious abortion is usually introduced into a clean herd by the purchase of a cow from an infected herd, or by a bull which has served an aborted cow. The practice of borrowing a bull from a neighbour is not an infrequent means of its spread. Examination of the newly introduced animals is useless, as it is practically impossible for a stockowner to tell whether a strange cow has aborted or not, or whether a bull has recently served an aborted cow. Some owners, when they find they have a cow which aborts, will sell the animal, and the purchaser, not knowing its history, will innocently be the means of infecting his own herd. Such a proceeding is one which cannot be too severely condemned, and it should be an offence to sell an animal from an aborting herd without stating the fact to the intending purchaser.

There is at present considerable want of knowledge amongst a large proportion of dairymen in the State as to the true nature of the disease; and letters are often sent from various sources inquiring why their cows slip their calves or why a large percentage remain barren?

THE CAUSE AND NATURE OF THE DISEASE.

The researches of Dr. Bang, the Danish veterinary surgeon, proved that contagious abortion was due to a specific germ. He discovered this germ in the envelopes of the foetus and between them and the walls of the womb during life before abortion occurred; also, in the abortion, the after-birth and the discharges from the genital passages of the animal which had aborted, and, by his introducing these germs into the genital passages or into the veins of a healthy in-calf cow, abortion was brought about. From this it is very evident that the aborting cow is a source of danger to healthy cows so long as the former harbours the virus or distributes it by the discharge from the genital passage, and it is only by preventing access of these germs to healthy animals that the stock-owner can hope to prevent an occurrence of the disease. Anything contaminated by the discharge from an aborting cow may be the means of conveying the disease to a healthy one; hence it will be understood that the floors, &c., of the bails, the spot in the paddock where the abortion has been dropped, certain parts of the animal which are soiled by the discharge, especially the tail, or a bull which has served an infected cow, may be a source of danger.

SYMPTOMS.

The symptoms of oncoming abortion are often very slight, and frequently there are no signs at all to warn the owner of the approaching trouble. The animal may be uneasy; sometimes there are slight colicky pains. There are modified indications of calving, and the milk is generally increased for no apparent reason. There may be a discharge from the genital passage. In a great many cases, however, the first indication the owner has that something is wrong is that the cow comes to the bull again about six or eight weeks after service. When a cow has slipped her calf, she usually comes into service from three to eight days after the abortion has occurred. In the great majority of cases, under the conditions obtaining in this State, first abortions are overlooked, and healthy animals may be contaminated before the presence of the disease is known. On the other hand, an infected cow may carry her calf at full time, but although this may happen, yet the cow is a source of danger to others.

An infected in-calf cow is liable to abort at any time, but the greatest number of abortions occur after the animal has been in calf about four months, and it is very important to bear in mind that a cow or heifer once aborted as a result of infection almost invariably has a tendency to abort again.

TREATMENT.

When a cow has aborted, the foetus or stillborn calf, together with the after-birth, should be burned and the ground upon which it has fallen well disinfected. Sheep dip or quicklime will do for this purpose. The aborted cow must be isolated from the healthy cows for two months; if practicable, using a separate bail for milking. Knowing that the disease is a highly contagious one, and that the germ causing it may be easily conveyed to healthy animals by any material soiled by the discharge from the genital passage of an infected cow, all endeavours should be directed towards preventing the contamination of the healthy cows taking place.

The aborted animal should then have her womb washed out with a solution of 1 part of perchloride of mercury (corrosive sublimate) in 2,000 parts of water. This chemical is highly poisonous, and should be kept away from stock or human beings.

Tabloids of corrosive sublimate may be readily obtained from a chemist, of such strength that one tabloid dissolved in a pint of water makes a 1-in-1,000 solution, and one dissolved in a quart of water makes a 1-in-2,000

solution. It should be made in an enamelled or wooden vessel, not a plain metal one, as this chemical has a corroding action on metal.

The solution for washing out the womb, &c., should first be made warm (blood heat), and the injection performed by means of an enamelled or glass funnel to which is attached sufficient length of rubber tubing (about 3 feet), with a bore of about $\frac{1}{2}$ an inch. A metal syringe cannot be used for reasons just given.

The hand carrying the free end of the tubing is inserted into the womb of the cow, care being taken not to injure the lining of the womb. The funnel is then held above the root of the tail, and about half a gallon of the corrosive sublimate solution poured into it. The fluid will gravitate into the womb. This should be done daily for a week. Besides this, every part that the tail can reach—such as the hindquarters, tail itself, back parts, escutcheon, and udder—should be washed down with the same kind of solution.

If the animal strains very much after injection, a dose of laudanum (about 2 tablespoonfuls in a pint of water) may be given as a drench by the mouth, but if she is allowed to rest quietly, as a rule, there is no occasion for alarm.

In the case of the other cows, one injection into the vagina is sufficient; but the external parts—such as the passage, tail, back parts, and udder—should be washed daily with the solution. The strength of this solution should be 1 part in 1,000 of water.

The floor and sides of the bails should be washed down once or twice a week with a solution of 1 part of copper sulphate (bluestone) in 20 parts of water. The person attending aborted cows should not attend healthy ones, or, where this is not practicable, he should thoroughly wash his hands in disinfectant before so doing.

The bull, if he has served an aborting cow, should be put in a crush and have his penis and sheath washed out with the corrosive sublimate solution (1 part in 2,000) daily, or at least after each service. It is not safe to use such bull for healthy cows for at least some weeks.

Do not allow the bull to serve outside cows.

Do not put an aborting cow to the bull for two or three months after abortion.

When abortion is present, the bull should not be allowed to run with the herd, as the practice of doing so is one of the factors in spreading the disease.

If only one cow is abortive, the cheapest and safest plan is to isolate her and fatten her for the butcher.

In order to prevent the disease being brought into healthy herds—

No outside bull should be allowed to serve the cows, nor should any outside cows be served by the bull. If this is done, however, he should be treated just as if it were known that he had served an infected cow.

It is not always practicable to isolate newly purchased cows or heifers; but they should be prevented from coming in contact with the rest of the herd until they are ascertained to be free from risk of infecting the latter, and their back parts, during this period, washed regularly as previously described while undergoing the quarantine.

The foregoing instructions entail a considerable amount of patience and perseverance, but they must be carried out thoroughly to ensure success. Half-hearted measures are worse than useless, as they tend to discredit a method of treatment which is known to be effectual. With determination and thoroughness, the disease will be conquered, although it must not be expected to disappear at once.

General Notes.

FRACTURED BONES IN DOGS.

Fractured bones in dogs, writes "Wattlebark" in the "Australasian," occasionally occur, and it is advisable for dog-owners to have some idea as to how to bandage the parts to prevent further damage, and until they can be seen by a vet., or, failing that expert, to put the dog into as good a position for recovery as it is possible to do. It is a wonder that a far larger number of fractured bones do not occur with dogs, as these animals are generally in the way where traffic is the heaviest or when the unexpected happens. Dogs, however, seem to have a charmed existence, and will slip through difficulties that apparently are ready to overwhelm them. As an instance, I remember one day seeing a fox terrier standing between the metal rails at a suburban railway station as a train came rushing in. The dog was quite unconscious of its approach, and the incident was too sudden even to give a warning yell. I could not but think that the dog was mangled, and I moved up to see what had occurred. As I did so I happened to look over to the other side of the roadway, and there I saw the noble fox terrier, with a big patch of engine grease on its shoulder—fighting with another dog.

The well-known canine specialist, Mr. A. J. Sewell, M.R.C.V.S., says that the symptoms of a fractured leg are deformity, pain, and swelling at the seat of the fracture, with crepitus or grating together of the broken ends of the bones when the parts are moved. There are three kinds of fracture—simple, when one or more bones are broken in two pieces, as in fracture of

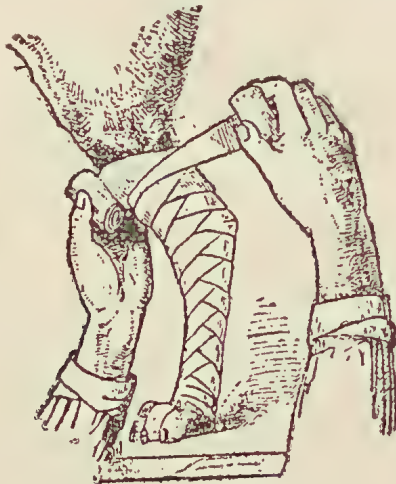

BANDAGING A DOG'S LEG.

the two bones (radius and ulna) of the foreleg or arm, and an absence of serious injury to the skin; compound, when, besides fractures of the bones, the skin and other tissues are torn, exposing the bones; and, comminutive, when a bone is crushed into several pieces. It is, of course, possible to have a compound comminutive fracture. There is a false form of fracture that occasionally occurs in puppies, especially of the larger breeds, more particularly when affected with rickets; that is the separation of the epiphyses

from the shaft of the bone. The epiphyses are the ends of the long bones, and in young animals they are joined to the main shaft by cartilage; later this becomes ossified or converted into bone.

In the fracture of the hock or the tibia, a bone that extends from the stifle joint to the hock, the same method of treatment applies. A splint made of thin zinc, which should be shielded from the skin by a padding of medicated wool, is to be placed above and below the seat of the fracture, the broken parts having previously been brought together. If the dog is big, two splints will be necessary.

In treating fractures, Mr. Sewell states that it is important to get them set and bandaged before the parts have had time to swell, otherwise in a few days, when the swelling has disappeared, the bandage will be found loose, and perhaps coming off, necessitating resetting and bandaging. When the setting has been properly carried out there is no occasion to remove the bandages in case of simple fracture, at any rate for a month; but if the splints have not been properly padded, they may rub the prominent parts of the joints or bones, causing bad wounds. When such is occurring, the dog is restless, and shows unmistakable signs of discomfort by constantly licking the parts; then the splints and bandages must be removed, and the sores washed and dressed by sprinkling the wound over with powdered iodoform before applying the splints and bandages again. The wound may require dressing every other day, or even every day, if the wound is a bad and deep one; in these cases a pad of some antiseptic gauze, as carbolic gauze, should be applied.

In treating small dogs with fracture of the leg, it is very important that the bandages should be as thin and light as possible. In these cases, have bandages made of thin muslin, or butter-cloth, about $1\frac{1}{2}$ in. wide by 4 yards long, which soak in a thick solution of gum acacia. This is put straight on the broken leg after it has been set. A good many layers must be put on, and over this four unpadded splints are adapted, and then a few layers of ordinary bandage to keep the splints in their place, and they, with the outside bandage, may be removed in a couple of days, by which time the gum has dried and set firmly.

Over ordinary bandages for fractures a few strips of sticking-plaster should be fixed to keep the bandages in place. The illustration will show the method of placing a bandage on a fractured leg. The bandage should be begun from the foot, and carried firmly up the leg.

BURNING OUT STUMPS.

We have, on several occasions, described the method of burning out stumps by the help of kerosene and saltpetre, and still requests for information on the matter reach us from time to time.

The process is not a new one, nor is it confined to Queensland, for in Canada it is recognised as the most simple way of getting rid of stumps without the heavy labour of extracting them by the use of axe, mattock, and shovel.

A Canadian says:—"In treating with saltpetre, we bore from one to three holes with a sharp 2-in. auger, according to the size of the stump. If a moderate-sized stump, one hole in the centre is sufficient, or, if the stump is very large, bore two or three holes in different sections. If at an angle to the grain they will bore much easier than straight down from the top. In each hole place 1 oz. of saltpetre, fill up with rain water and plug closely with wood. The water will dissolve the saltpetre and carry it to all portions of the stump, opening up the grain pores. As soon as the water is absorbed, which will be in from four to six weeks in dead stumps, and somewhat longer in green ones, uncork, fill the hole with kerosene oil, and again cork tightly.

As soon as the oil has been absorbed, which will be in a few days, possibly one week, the stump is ready to fire. After a good fire is started, it is not much trouble to get rid of the stump. We have had a large oak stump, 5 or 6 ft. in diameter, burn entirely away, root and crown."

The dry weather of autumn and winter (in Queensland) is the best time to burn them out, as the roots then hold very little moisture to retard burning.

WHAT A GOOD MILCH COW SHOULD YIELD.

The Canadian Department of Agriculture, in order to determine the above question, arranged a series of tests of first-class milkers, and laid down certain conditions which were accepted by local societies which entered upon the work. Amongst the conditions it was stipulated that all animals entering for the test must previously be entered in a Canadian herd-book testifying to their purity, and that the scope of the test should last for a period not exceeding one year.

The standard laid down for the Ayrshire cow is as follows:—

| | Lb. Milk. | Lb. Butter Fat. |
|-----------------------------|-----------|-----------------|
| Two-year-old class | 5,500 | 198 |
| Three-year-old class | 6,500 | 234 |
| Four-year-old class | 7,500 | 270 |
| Mature class | 8,500 | 306 |

That for the French-Canadian is as follows:—

| | Lb. Milk. | Lb. Butter Fat. |
|-----------------------------|-----------|-----------------|
| Two-year-old class | 4,400 | 198 |
| Three-year old class | 5,200 | 234 |
| Four-year-old class | 6,000 | 270 |
| Mature class | 6,800 | 306 |

THE FLAX INDUSTRY.—DECREASED PRODUCTION.

Returns compiled by the chief fibre expert (Mr. Fulton) of hemp and tow exported during the month of February (says the "New Zealand Farmer"), show a considerable falling-off compared with the corresponding period of 1908. Although there was an increase for February over January, the output graded for last month amounted to 8,788 bales, or 4,040 bales less than for February, 1908.

The twelve months ended February, 1909, show a falling off of 63,775 bales. For the year ended 28th February, 1909, the total was 78,573 bales, whereas for the year ended 28th February, 1908, the quantity graded for export amounted to 143,348 bales.

In regard to tow, which was graded for the first time last month, 1,603 bales passed through the graders' hands. Of this, 47 bales were No. 1, 455 No. 2, and 1,063 No. 3, while 38 were condemned.

Wellington shipments of hemp amounted to 3,708 bales for the month, compared with 5,096 bales for the same month last year. Wellington also shipped 655 bales of tow.

BANANA MARGARINE.

Banana margarine is among the latest novelties now being placed on the market in England. A food expert has elaborated a process of blending bananas with milk, butter, and other wholesome ingredients, and has produced a natural food product resembling in appearance and texture choicest Danish butter, and characterised by the flavour of the banana. To protect this process, patent rights have been applied for in the United Kingdom and the Isle of Man by the inventor, and the Board of Agriculture and Fisheries has approved of the sale of the article under the name "banana margarine."

It is claimed that the product will save the housewife 25 per cent. on cost compared with butter, and give the retailer a clear profit of 25 per cent. Steps are being taken to secure patent rights on the Continent and in the colonies. The quality and flavour of the new article are stated to be excellent.—“Sydney Mail.”

TO DESTROY MICE IN THE GARDEN.

Traps of the following description—earthenware or glass jars, each with a good shoulder, as in the sketch—should be sunk in the ground so that the tops become level with the surface. While the jars are dry, fix some pieces of lard or dripping inside, close up underneath the shoulders, then

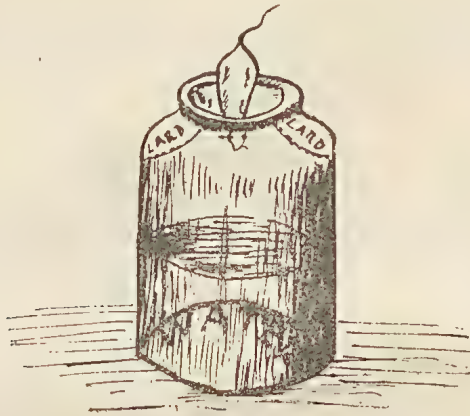

half fill the jars with water. The mice, in attempting to reach the lard, fall in and get drowned. These traps require very little attention, and can remain set without danger to other animals. Remove the dead mice as often as necessary.

Answers to Correspondents.

RINGBARKING.

J. TAIT, Tewantin.—

As a general rule the proper time to ringbark the trees you mention is when they are in full growth and the sap is up. The difficulty lies in the fact that these trees are not all in strong growth at the same time, consequently if a contract is let to ringbark, the contractors ringbark every tree on the land, with the result that many will shoot from the roots and stumps. The proper way is to note what trees are vigorously growing, and to ringbark these, leaving the rest until they also are in the same condition of growth. There is no need to ringbark oaks; better to cut them down, and the stumps will very soon begin to rot. They do not shoot from the stumps, but oaks should not be allowed to be in full seed before felling, otherwise you will have a fine crop of young trees, which will have to be pulled up when young.

SHE OAK AND TI-TREE.

“FORESTER,” Woombye.—

The “She Oak” is not an oak-tree. It belongs to the order “Casuarinae,” natives chiefly of Australia. The term “oak” is a misnomer, and as for “She Oak,” that is a corruption of the native name in Tasmania, “Cheek.” In the same way Tea Tree or Ti-tree has nothing to do with the Tea plant. The name is derived from “ti-ti,” meaning “little leaf.”

DRIED BLOOD AND SWEET POTATOES FOR FOWLS—SWEET POTATO VINES FOR HORSES—RIPE WATERMELONS—ROUGH ANALYSIS OF SOILS.

W. E. PEARSON, Aspley, Brisbane.—

1. Is dried blood good for fowls in place of meat for laying hens?

From the analysis of dried blood it is shown that it contains everything needed for the production of eggs.

2. Are sweet potato vines good for horses?

Great care is needed in feeding sweet potato vines to any stock. Analyses of the vines have shown that they yield as much as 1 grain of prussic acid (a deadly poison) per lb. of the green feed. In 1905 numbers of pigs died from eating sweet potato vines. If used at all for stock, it should be very sparingly.

3. Are sweet potatoes good feed for laying fowls?

In feeding green food to fowls it is well to mix two or three kinds. Sweet potatoes, mangolds, cabbage, sugar-beets, and lucerne are all good.

4. Are oats good feed for laying fowls?

Yes; excellent food.

5. What is the most reliable way to tell when watermelons are ready for market?

When the melon is ripe the curl near the fruit will wither. If on pressing the melon between the hands a cracking sound is heard inside, the fruit is ripe. Never cut a hole to find out, as some do.

6. Is there any simple way to tell whether my soil lacks phosphoric acid or potash, in a rough way?

No. You can, by a rough method, ascertain the presence of humic acid, lime, magnesia, and hydrate of alumina combined with phosphoric acid, but for quantity or deficiency of phosphoric acid and potash a chemical analysis is necessary. See “Q.A.J.,” Vol. XIII., Aug., 1903, p. 211, “To Roughly Ascertain the Composition of Soils.”

COST OF FERTILISER FOR MAIZE.

R. H. WITTY, Yatala.—

| | | | | |
|----------------------------|--------|-----|-----|---------------|
| | No. 1. | | | |
| 160 lb. sulphate of potash | ... | ... | ... | 24s. |
| 160 lb. superphosphate | ... | ... | ... | 12s. |
| | | | | 36s. per acre |
| | No. 2. | | | |
| 160 lb. nitrate of soda | ... | ... | ... | 24s. |
| 320 lb. superphosphate | ... | ... | ... | 24s. |
| 160 lb. sulphate of potash | ... | ... | ... | 24s. |
| | | | | 72s. per acre |

No. 1 is not a complete manure, and requires the addition of nitrogen in the form of nitrate of soda, or of dried blood to give good results.

No. 2 is a complete manure, but contains too much superphosphate. Mr. Brünnich, Agricultural Chemist, recommends as a general complete fertiliser, per acre:—

| | | | | |
|---------------------------|-----|-----|-----|---------------|
| 1½ cwt. nitrate of soda | ... | ... | ... | 24s. |
| 1 cwt. potassium sulphate | ... | ... | ... | 16s. |
| 1 cwt. superphosphate | ... | ... | ... | 8s. |
| | | | | 78s. per acre |

These are all quick-acting soluble manures, and will chiefly benefit the crop to which they are applied.

The administration of molasses to cattle has no effect whatever in preventing an attack of redwater. However, as it is, to some extent, a food, although not a well-balanced one, the feeding of molasses to an animal whilst sick may assist in keeping up the latter's strength. It also acts as a mild laxative, and therefore is beneficial for its action in that respect.

THE QUEENSLAND AGRICULTURAL JOURNAL.

PEDAGOGUE, Teutoberg.—

The Journal is supplied to State school head teachers on payment of 1s. annually to cover postage.

Publication Received.

THE OFFICIAL YEAR-BOOK OF THE COMMONWEALTH, No. 2.

We have received from the Commonwealth Statistician (Mr. G. H. Knibbs, F.S.S., &c.), a copy of the second "Official Year Book" of the Commonwealth of Australia, dated 1909, and just published under the authority of the Hon. H. Mahon, M.P., Minister for Home Affairs. The first number of the Year Book, published last year, was so favourably received and was in such demand that this year it has been considered necessary to largely increase the number published.

The statistics comprised in the new volume are, as far as possible, given for each State and for every year since the inauguration of the Commonwealth, including particulars for the year 1908, so far as they have been compiled. The publication also furnishes corrected figures from the earliest times, in some cases dating as far back as 1788.

In addition to the matter usually contained in a publication of this description, the Year Book is supplemented by the inclusion of a large number of new maps, tables, diagrams, and graphs. Some of the sections given in the first Year Book have now been considerably condensed, while others have been elaborated, and new articles dealing with matters of special interest have been added.

Among the subjects on which new articles have been introduced, the following may be specially mentioned:—The Exploration of Australia (with maps); The Constitutions of the States; The Hydrology of Australia (with lengths of rivers); The Development of Australia's Trade with the East; The Customs Tariff, 1908; Kindergarten Education; Administrative Government; Public Lighting; Papua; and Local Option. The article on Manufacturing Industries has been rewritten, and contains a number of new tables, while a great part of the article on Railways is also new. The subject of Land Tenure and Settlement is dealt with exhaustively, and a comprehensive description in a classified and co-ordinated form of the land systems of the several States is published, it is believed, for the first time. A number of new maps, in addition to those comprised in the last Year Book, are also included in the publication, such, for instance, as the maps of the Geology of Australia, the Orography of Australia, the Progress of Exploration, and Australia and New Guinea.

A feature of the Year Book worthy of note is that the latest returns available up to the hour of going to press have been included in an Appendix.

It is evident in the present publication that the scheme of co-ordination of statistics outlined and agreed upon at the Statistical Conference of 1906 has resulted in considerable improvement in the collection and presentation of Australian statistics on a uniform basis, so that the returns for the several States are now in nearly every case directly comparable.

The Commonwealth Year Book is a compendium of all matters affecting the economic and industrial conditions of Australia, and is a *sine qua non* for the publicist for purposes of reference.

The Markets.

PRICES OF FRUIT—ROMA-STREET MARKETS.

| Article. | MAY. | |
|--|--------------------|--|
| | Prices. | |
| Apples (Hobart), per case | 5s. to 8s. | |
| Apples (Victorian), per case | 4s. to 7s. | |
| Apples (Local), per case | 3s. to 4s. 6d. | |
| Bananas (Cavendish), per dozen | 2d. | |
| Bananas (sugar), per dozen | 1d. to 1½d. | |
| Cape gooseberries, per box | 8s. to 9s. 6d. | |
| Custard Apples, per quarter-case | 3s. to 5s. | |
| Lemons (Italian), per case | 9s. | |
| Lemons (Sydney), per case | 7s. | |
| Mandarins, per case | 3s. 9d. to 8s. 6d. | |
| Oranges (Northern), per case | 5s. | |
| Oranges (Local), per case | 2s. to 4s. 1d. | |
| Papaw Apples, per quarter-case | 1s. 6d. | |
| Passion Fruit, per quarter-case | 2s. 9d. to 3s. | |
| Pears (Hobart), per quarter-case | 6s. | |
| Pears (Victorian), per quarter-case | 8s. 6d. to 9s. | |
| Persimmons | 1s. 6d. to 3s. 9d. | |
| Pineapples, rough, per dozen | 2s. 6d. | |
| Pineapples, smooth, per dozen | 3s. 6d. to 4s. 6d. | |
| Pineapples, Ripley Queen, per dozen | 2s. 6d. to 3s. | |
| Quinces, per case | 1s. 7d. to 3s. 8d. | |
| Rosellas, per sugar bag | 2s. 6d. | |
| Tomatoes, per quarter-case | 1s. 9d. to 3s. | |

SOUTHERN FRUIT MARKET.

| | |
|---|--------------------|
| Apples (Hobart), per case | 6s. 6d. |
| Apples (Victorian), per case | 4s. to 5s. |
| Apples (Local), per case | 9s. |
| Apples (cooking), per case | 3s. 6d. to 5s. |
| Bananas (Queensland), per bunch | 1s. to 3s. |
| Bananas (Queensland), per case | 5s. 6d. to 7s. |
| Grapes (Adelaide), per box (36 lb.) | 5s. 6d. to 6s. |
| Lemons (Local), per gin case | 7s. |
| Lemons (Italian), per box | 7s. to 8s. |
| Lemons (Italian), per half-case | 7s. to 8s. |
| Mandarins (Local Emperors), special, per gin case | 12s. to 13s. |
| Mandarins (other), per half-case | 5s. |
| Mangoes, per case | ... |
| Nectarines, per half-case | ... |
| Oranges (Local), per gin case | 6s. |
| Passion Fruit (Choice), per half-case | 5s. to 6s. |
| Peanuts, per lb. | 5½d. |
| Pears (Choice), per gin case | 12s. |
| Pears (medium), per gin case | ... |
| Pears (China), per gin case | 1s. 6d. to 2s. |
| Persimmons, per box | 3s. |
| Pie-melons, per dozen | 1s. 2d. |
| Pineapples (Queensland), Ripley Queen, per case (choice) | 6s. to 7s. 6d. |
| Pineapples (Queensland), Choice, Queens, per case | 6s. to 7s. 6d. |
| Pineapples (Queensland), Choice Common, per case | 6s. to 7s. |
| Pineapples (Queensland), Small, Common, per case | 4s. 6d. to 5s. 6d. |
| Plums, per half-case | ... |
| Quinces, per gin case | 3s. |
| Rock melons, per dozen | 2s. to 4s. |
| Strawberries (Local), per dozen punnets | ... |
| Tomatoes (Local), choice, per half-case | 2s. to 2s. 6d. |
| Water Melons, per dozen | 6s. |

**PRICES OF FARM PRODUCE IN THE BRISBANE MARKETS FOR
MAY.**

| Article. | | MAY. |
|---------------------------|-------|---------------------|
| | | Prices. |
| Bacon, Pineapple | lb. | 8½d. to 10d. |
| Barley, Malting | " | 3s. 6d. to 3s. 9d. |
| Bran | ton | £6 15s. |
| Butter, Factory | lb | 1s. |
| Chaff, Mixed | ton | £5 10s. |
| Chaff, Oaten | " | £4 15s. to £5 5s. |
| Chaff, Lucerne | " | £5 5s. to £7 5s. |
| Chaff, Wheaten | " | £4 10s. to £5 10s. |
| Cheese | lb. | 7½d. to 8d. |
| Flour | ton | £12. |
| Hay, Oaten | " | £5 10s. to £6. |
| Hay, Lucerne | " | £4 5s. to £6. |
| Honey | lb. | 2d. to 2¼d |
| Maize | bush. | 4s. 3d. to 4s 4d. |
| Oats | " | 3s. 2d. to 3s. 4d. |
| Pollard | ton | £6 15s. |
| Potatoes | " | £5 to £7. |
| Potatoes, Sweet | " | ... |
| Pumpkins | " | ... |
| Wheat, Milling | bush. | 5s. to 5s 3d. |
| Wheat, Chick | " | 4s. 9d. |
| Onions | ton | £8 to £8 5s. |
| Hams | lb. | 1s. to 1s. 1d. |
| Eggs | doz. | 1s. 3½d. to 1s. 8d. |
| Fowls | pair | 2s. 3d. to 3s. 6d. |
| Geese | " | 5s. to 6s. |
| Ducks, English | " | 3s. to 3s. 4d. |
| Ducks, Muscovy | " | 3s. 9d. to 4s. 6d. |
| Turkeys (Hens) | " | 6s. 3d. to 7s. |
| Turkeys (Gobblers) | " | 9s. to 16s. |

ENOGGERA SALEYARDS.

| Animal. | | APRIL. |
|-----------------------------------|--|---------------------------|
| | | Prices. |
| Butlocks | | £7 17s. 6d. to
£9 10s. |
| „ (single) | | £10. |
| Cows | | £5 17s. 6d. to £7 7s. 6d. |
| Merino Wethers | | 14s. 9d. |
| Crossbred Wethers | | 15s. |
| Crossbred Wethers (single) | | 23s. 6d. |
| Merino Ewes | | 13s. |
| Crossbred Ewes | | 17s. 9d. |
| Lambs | | 11s. 3d. |

Farm and Garden Notes for July.

FIELD.—The month of July is generally considered the best time to sow lucerne, for the reason that the growth of weeds is practically checked, and the young lucerne plants will therefore not be choked by them, as would be the case if planted later on in the spring. If the ground has been properly prepared by deep ploughing, cross-ploughing, and harrowing, and an occasional shower occurs to assist germination and growth, the lucerne will thrive so well that by the time weeds once more appear, it will be able well to hold its own against them. From 10 to 12 lb. of seed will be sufficient for an acre. This is also the time to prepare the land for most field crops—such as potatoes, maize, oats, barley, rye, vetches, tobacco, cotton, sugar-cane, field carrots, mangolds, swedes, canaigre, &c. Early potatoes, sugar-cane, and maize may be planted in very early districts, but it is risky to plant potatoes in this month in any districts liable to late frosts and in low-lying ground; it is better to wait till the following month. The greatest loss in potatoes and sugar-cane has been experienced in September, when heavy frosts occurred in low-lying districts in the Southern portion of the State. During suitable weather, rice may be sown in the North. The coffee crop should now be harvested, and yams and turmeric unearthed.

KITCHEN GARDEN.—Should showery weather be frequent during July, do not attempt to sow seeds on heavy land, as the latter will be liable to clog, and hence be injurious to the young plants as they come up. The soil should not be reworked until fine weather has lasted sufficiently long to make it friable. Never walk over the land during wet weather with a view to sowing. The soil cakes and hardens, and good results cannot then be expected. This want of judgment is the usual cause of hard things being said about the seedsman. In fine weather, get the ground ploughed or dug, and let it lie in the rough till required. If harrowed and pulverised before that time, the growth of weeds will be encouraged, and the soil is deprived of the sweetening influences of the sun, rain, air, and frost. Where the ground has been properly prepared, make full sowings of cabbage, carrot, broad beans, lettuce, parsnips, beans, radishes, leeks, spring onions, beetroot, eschalots, mustard and cress, &c. As westerly winds may be expected, plenty of hoeing and watering will be required to ensure good crops. Pinch the tops of broad beans which are in flower, and stake up peas which require support. Plant out rhubarb, asparagus, and artichokes. In warm districts it will be quite safe to sow cucumbers, marrows, squashes, and melons during the last week of the month. In colder localities, it is better to wait till the middle or end of August. Get the ground ready for sowing French beans and other spring crops.

FLOWER GARDEN.—Winter work ought to be in an advanced state. The roses will now want looking after. They should already have been pruned, and now any shoots which have a tendency to grow in wrong directions should be rubbed off. Overhaul the ferneries, and top-dress with a mixture of sandy loam and leaf-mould, staking up some plants and thinning out others. Treat all classes of plants in the same manner as the roses, where undesirable shoots appear. All such work as trimming lawns, digging beds, pruning and planting, should now be got well in hand. Plant out antirrhinums, pansies, hollyhocks, verbenas, petunias, &c., which were lately sown. Sow zinnias, amaranthus, balsams, chrysanthemum tricolour, marigold, cosmos, coxcombs, phloxes, sweet peas, lupins, &c. Plant gladiolus, tuberose, anaryllis, pan-cratiun, ismene, crinums, belladonna, lily, and other bulbs. Put away dahlia roots in some warm, moist spot, where they will start gently, and be ready for planting out in August and September.

Orchard Notes for July.

By ALBERT H. BENSON, M.R.A.C.

THE SOUTHERN COAST DISTRICTS.

The notes for the month of June apply to July as well. The first crop of strawberries will be ripening during the month, though extra early fruit is often obtained in June, and sometimes as early as May, under especially favourable conditions. Look out for leaf-blight, and spray for same with Bordeaux mixture, also watch for the first signs of the grey mould that attacks the fruit, and spray with the sulphide of soda wash. The larvæ of the cockchafer, that eats the roots of strawberries, should be looked for, and destroyed whenever found. Pruning of citrus and other fruit trees may be continued; also, the spraying with lime and sulphur. Where the ringing borer, that either attacks the main trunk or the branches at or near where they form the head of the tree, is present, the main stems and trunks should either be painted or sprayed with the lime and sulphur wash during the month, as the mature beetles that lay the eggs that eventually turn to the borers sometimes make their appearance during the month, and unless the trees are protected by the wash they lay their eggs, which hatch out in due course, and do a lot of damage. Keep the orchard clean, so that when the spring growth takes place the trees may be in good condition. There is usually a heavy winter crop of pineapples ripening during this and the following months, particularly of smooth leaves. See that any conspicuous fruits are protected by a whisp of grass, as they are injured not only by frost but by cold westerly winds.

THE TROPICAL COAST DISTRICTS.

See the instructions given for the month of June. Keep the orchards clean, and well worked. Prune and spray where necessary.

THE SOUTHERN AND CENTRAL TABLELANDS.

Where pruning of deciduous trees has not been completed, do so this month. It is not advisable to leave this work too late in the season, as the earlier the pruning is done after the sap is down the better the buds develop—both fruit buds and wood buds—thus securing a good blossoming, and a good growth of wood the following spring.

Planting can be continued during the month; if possible, it should be finished this month, for, though trees can be set out during August, if a dry spell comes they will suffer, when the earlier planted trees, which have had a longer time to become established, will do all right—provided, of course, that the land has been properly prepared prior to planting, and that it is kept in good order by systematic cultivation subsequent to planting.

Do not neglect to cut back hard when planting, as the failure to do so will result in a weakly growth.

As soon as the pruning is completed, the orchards should get their winter spraying with the sulphide lime-wash, and either with or without salt, as may be wished. See that this spraying is thoroughly carried out, and that every part of the tree is reached, as it is the main treatment during the year for San José and other scale insects, as well as being the best time to spray for all kinds of canker, bark-rot, moss, lichens, &c.

Where the orchard has not been ploughed, get this done as soon as the pruning and spraying is through, so as to have the land in good order for the

spring cultivations. See that the work is well done, and remember that the best way to provide against dry spells is to keep moisture in the soil once you have got it there, and this can only be done by thorough and deep working of the soil.

When obtaining trees for planting, see that they are on good roots, and that they are free from all pests, as it is easier to prevent the introduction of pests of all sorts than to eradicate them once they have become established. Only select those varieties that are of proved merit in your district; do not plant every kind of tree that you see listed in a nurseryman's catalogue, as many of them are unsuited to our climate. The pruning of grape vines may be carried out in all parts of the tablelands other than the Stanthorpe district, where it is advisable to leave this work as long as possible, owing to the danger of spring frosts.

Where grape vines have been well started and properly pruned from year to year, this work is simple; but where the vines have become covered with long straggling spurs, and are generally very unsightly, the best plan is to cut them hard back, so as to cause them to throw out good strong shoots near the main stem. These shoots can be laid down in the place of the old wood in following seasons, and the whole bearing portion of the vine will be thus renewed.

Where vineyards have been pruned, the prunings should be gathered and burnt, and the land should receive a good ploughing.

Times of Sunrise and Sunset at Brisbane, 1909.

| DATE. | MAY. | | JUNE. | | JULY. | | AUGUST. | | PHASES OF THE MOON.
<small>H. M.</small> |
|-------|--------|-------|--------|-------|--------|-------|---------|-------|---|
| | Rises. | Sets. | Rises. | Sets. | Rises. | Sets. | Rises. | Sets. | |
| 1 | 6.13 | 5.16 | 6.30 | 5.0 | 6.39 | 5.3 | 6.30 | 5.18 | 5 May ○ Full Moon 10 8 p.m. |
| 2 | 6.14 | 5.16 | 6.31 | 5.0 | 6.39 | 5.4 | 6.30 | 5.19 | 13 „) Last Quarter 7 45 a.m. |
| 3 | 6.14 | 5.15 | 6.31 | 5.0 | 6.39 | 5.4 | 6.29 | 5.19 | 19 „ ● New Moon 11 42 p.m. |
| 4 | 6.15 | 5.14 | 6.32 | 5.0 | 6.39 | 5.4 | 6.29 | 5.20 | 27 „ (First Quarter 11 28 a.m. |
| 5 | 6.15 | 5.13 | 6.32 | 5.0 | 6.39 | 5.5 | 6.28 | 5.20 | |
| 6 | 6.16 | 5.13 | 6.33 | 5.0 | 6.39 | 5.5 | 6.27 | 5.21 | |
| 7 | 6.16 | 5.12 | 6.33 | 5.0 | 6.39 | 5.6 | 6.26 | 5.21 | |
| 8 | 6.17 | 5.11 | 6.33 | 4.59 | 6.39 | 5.6 | 6.26 | 5.22 | 4 June ○ Full Moon 11 25 a.m. |
| 9 | 6.18 | 5.10 | 6.34 | 4.59 | 6.39 | 5.7 | 6.25 | 5.22 | 11 „) Last Quarter 0 43 p.m. |
| 10 | 6.18 | 5.10 | 6.34 | 4.59 | 6.39 | 5.7 | 6.24 | 5.23 | |
| 11 | 6.19 | 5.9 | 6.35 | 4.59 | 6.39 | 5.7 | 6.23 | 5.23 | 18 „ ● New Moon 9 28 a.m. |
| 12 | 6.19 | 5.8 | 6.35 | 4.59 | 6.38 | 5.8 | 6.22 | 5.24 | |
| 13 | 6.20 | 5.8 | 6.35 | 4.59 | 6.38 | 5.8 | 6.22 | 5.24 | 26 „ (First Quarter 4 43 „ |
| 14 | 6.20 | 5.7 | 6.36 | 4.59 | 6.38 | 5.9 | 6.21 | 5.25 | |
| 15 | 6.21 | 5.7 | 6.36 | 5.0 | 6.38 | 5.9 | 6.20 | 5.25 | |
| 16 | 6.22 | 5.6 | 6.37 | 5.0 | 6.37 | 5.10 | 6.19 | 5.26 | 3 July ○ Full Moon 10 17 p.m. |
| 17 | 6.22 | 5.6 | 6.37 | 5.0 | 6.37 | 5.10 | 6.18 | 5.26 | 10 „) Last Quarter 4 58 „ |
| 18 | 6.23 | 5.5 | 6.37 | 5.0 | 6.37 | 5.11 | 6.17 | 5.27 | 17 „ ● New Moon 8 45 „ |
| 19 | 6.23 | 5.5 | 6.37 | 5.0 | 6.37 | 5.11 | 6.16 | 5.27 | |
| 20 | 6.24 | 5.4 | 6.37 | 5.0 | 6.36 | 5.12 | 6.15 | 5.28 | 25 „ (First Quarter 9 45 „ |
| 21 | 6.25 | 5.4 | 6.38 | 5.0 | 6.36 | 5.12 | 6.14 | 5.28 | |
| 22 | 6.25 | 5.3 | 6.38 | 5.0 | 6.36 | 5.13 | 6.13 | 5.29 | |
| 23 | 6.26 | 5.3 | 6.38 | 5.1 | 6.35 | 5.13 | 6.12 | 5.30 | 2 Aug. ○ Full Moon 7 14 a.m. |
| 24 | 6.26 | 5.3 | 6.38 | 5.1 | 6.35 | 5.14 | 6.11 | 5.31 | 8 „) Last Quarter 10 10 p.m. |
| 25 | 6.27 | 5.2 | 6.39 | 5.1 | 6.34 | 5.14 | 6.10 | 5.31 | |
| 26 | 6.27 | 5.2 | 6.39 | 5.1 | 6.34 | 5.15 | 6.9 | 5.31 | 16 „ ● New Moon 9 55 a.m. |
| 27 | 6.28 | 5.2 | 6.39 | 5.2 | 6.33 | 5.15 | 6.8 | 5.32 | |
| 28 | 6.28 | 5.1 | 6.39 | 5.2 | 6.33 | 5.16 | 6.7 | 5.32 | 24 „ (First Quarter 1 55 p.m. |
| 29 | 6.29 | 5.1 | 6.39 | 5.2 | 6.32 | 5.16 | 6.6 | 5.32 | |
| 30 | 6.29 | 5.1 | 6.39 | 5.3 | 6.32 | 5.17 | 6.5 | 5.33 | 31 „ ○ Full Moon 3 8 „ |
| 31 | 6.30 | 5.0 | ... | ... | 6.31 | 5.17 | 6.4 | 5.33 | |



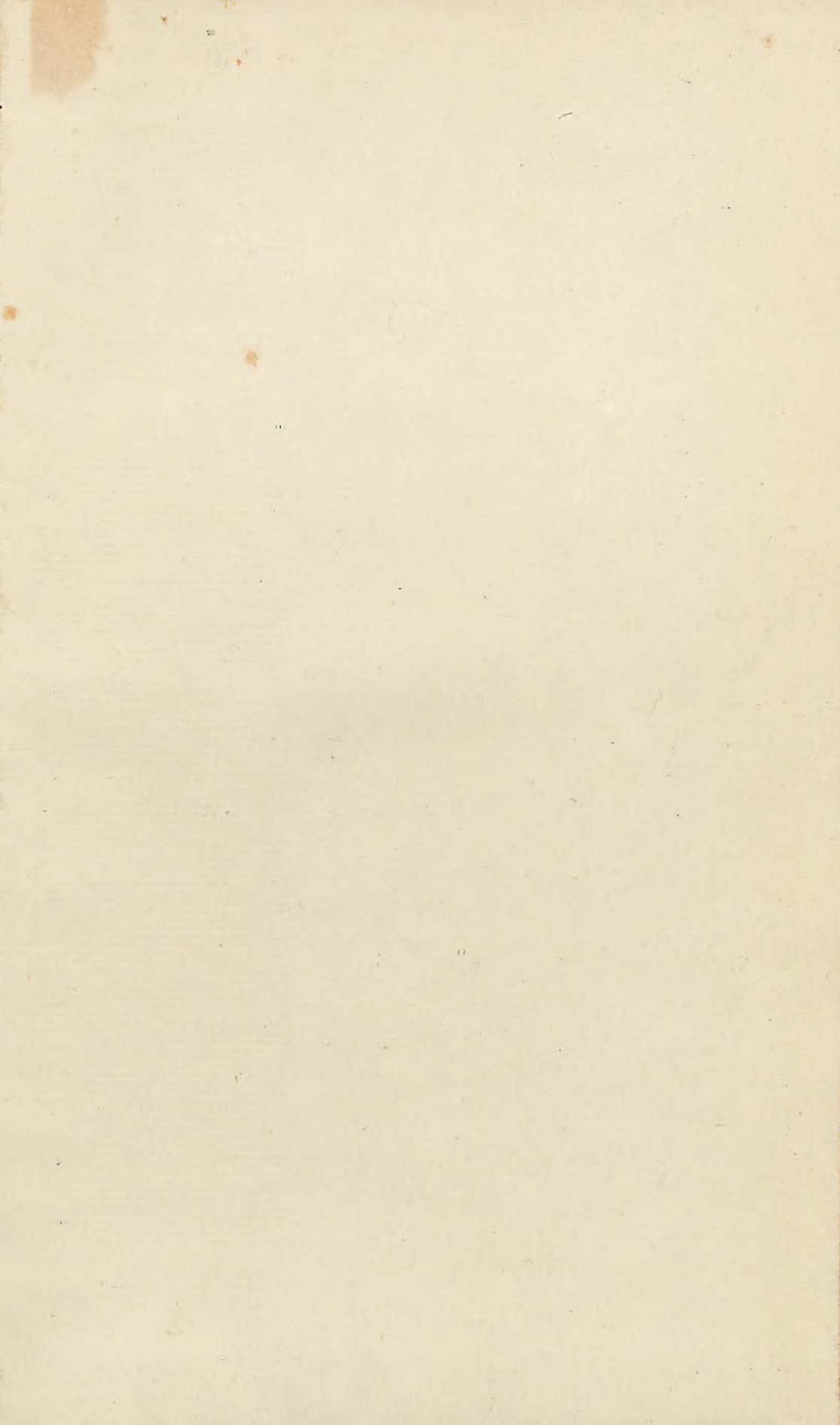

Royal Botanic Gardens Victoria



RBG00019212

