



Bound 697185
Periodical

**Kansas City
Public Library**



This Volume is for
REFERENCE USE ONLY

PUBLIC LIBRARY
CANTON CITY
188

From the collection of the

o P^zreⁿL^minger^a
v Library
t p

San Francisco, California
2007

WORLD
WIDE
WIRE

NOVEMBER

1929

Public Library

RADIO

BROADCAST

PUBLISHED FOR THE RADIO INDUSTRY



SPECIAL FEATURES IN THIS ISSUE

Radio's Greatest Year

Can the Dealer Tie in With Broadcasting?

What Are the Trends in Radio Models?

Factors in Expanding a Dealer's Business · Retail Chains in Radio · Can Service Pay a Profit? · Test
Sales Ideas · Principles of Linear Detection · Power Transformer Design · Data on Band-Pass Circuit

THIRTY FIVE CENTS

DUNN, DORAN & CO., INC. ♦ GARDEN CITY, NEW YORK

WASH. D. C.
 VTD. 2-28-31
 08



2-V PAM 19

New York Parks are **PAM** Equipped

In Central Park, New York, programmes such as Goldman's Band, speeches originating in the bandstand, etc., are picked up and amplified by a PAM amplifier similar to that illustrated above and fed over wires to twenty-five municipal parks in other sections of the city.



One of New York's Parks

In each of these parks is installed a 2V PAM-19 shown at the left which supplies reproducers located at proper points, thus permitting simultaneous quality reproductions at widely separated points.

The parks in your city are logical prospects for a similar type of equip-

ment. Have you seen the park authorities?

A new 16-page bulletin giving mechanical and electrical characteristics, representative installations, and many new PAM amplifiers will be sent upon receipt of 10 cents in stamps to cover postage. When writing ask for bulletin No. RB12.

Main Office:
 Canton, Mass.



Factories at Canton
 and Watertown, Mass.

MEMBER
RMA
 Bound
 Periodical
 Manufacturers Since 1882

JAN 6 '31

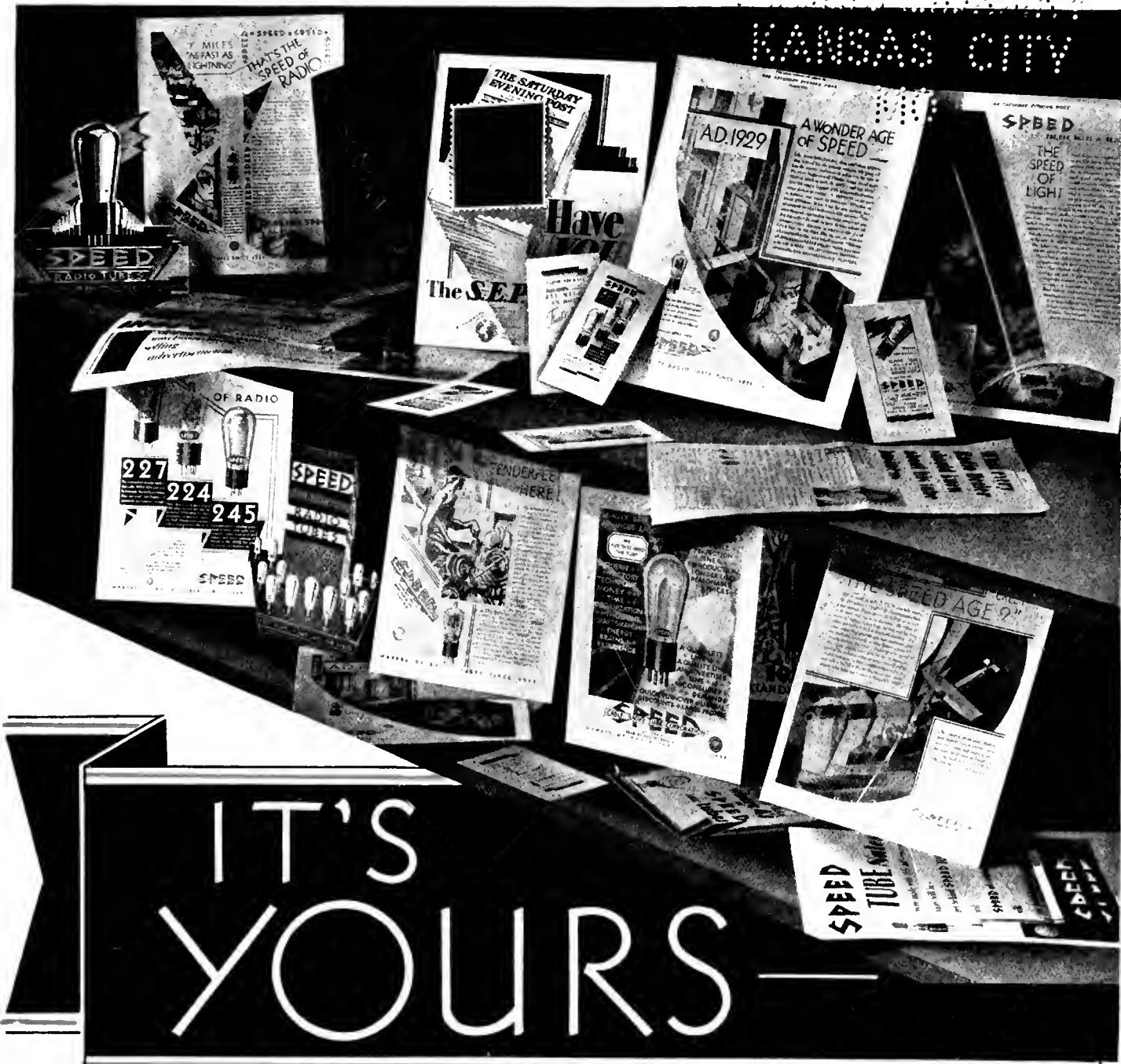

IT'S YOURS

All this advertising material — newspapers — magazines — trade papers — folders — brochures — broadsides — and many other novelties. (Remember the SPEED pistols at the Trade Show? Ask any man who was there!) SPEED advertising backs SPEED sales nationally and locally. Every day is "moving" day with SPEED advertising — it "moves" SPEED Tubes from your shelves to your customers' sets. A few SPEED jobber franchises are still available. SPEED quality + SPEED advertising + your sales ability = an unbeatable combination. The answer will be in \$ and ¢; mostly \$. Get 'em! Write right now!!

CABLE RADIO TUBE CORPORATION
 84-90 North Ninth Street
 Brooklyn, New York

MAKERS OF RADIO TUBES SINCE 1924

RADIO BROADCAST

PUBLISHED FOR THE RADIO INDUSTRY

WILLIS KINGSLEY WING Editor
 KEITH HENNEY Director of the Laboratory
 HOWARD E. RHODES Technical Editor
 EDGAR H. FELIX Contributing Editor



VOL. XVI. NO. 1

Contents for November, 1929

MERCHANDISING SECTION

The Radio World's Fair - - - - -	11
Views of Nine New Receiver Chassis - - - - -	13
Let's Look at Radio's Largest Year - - - - T. A. Phillips	14
What Made This Dealer Succeed - - - - Edgar H. Felix	16
Service—Do You or Your Customers Pay? John S. Dunham	18
Tested Sales Ideas - - - - - Merchandising Shorts	20
Typing in with Factory Advertising	A Novel Sales Stunt
The Gas Station Is a Prospect	An Automobile as a Sales Builder
Selling Radio - - - - - Howard W. Dickinson	22
Professionally Speaking - - - - - Keith Henney	24
Problems for Standards Committees	Our Service Problem
Yesterday, To-day, and To-morrow - What Dealers Suggest	25
What They Say - - - - - Interesting Letters	27
A Good Side Line for Radio Dealers	The Time Payment Problem
How Sales by States Compare - - - - -	27
The March of Radio - - - - - An Editorial Interpretation	28
If Automobile Dealers Sell Radio	The New Monitoring Station
More Patent Difficulties on the Way	Radio's Largest Chain Store
	Radio Commission Reorganized
The Tube Business - - - - - News of the Tube Industry	30
Views of the Hazeltine Laboratories - - - - -	31
News of the Radio Industry - - - - -	32
In the Radio Marketplace - - Offerings of Manufacturers	36
The Serviceman's Corner - - - - -	38
Strays from the Laboratory - - - - - Technical Shorts	40
A.R.C. Radio Altimeter	Advice to Students
Linear Detection	Screen-Grid Ratings

ENGINEERING SECTION

Characteristics of A.F. Transformers - - - H. M. Turner	43
Designing the Power Supply Circuit - - - Richard F. Shea	47
Linear Power Detection - - - - - Frederiek Emmons Terman	49
"Radio Broadcast's" Set Data Sheets - - - - -	51
The Gillilan Model 100	The Kennedy Model 10
An Efficient Radio Set Diagnoser - - - - - Herbert M. Isaacson	52
A High-Resistance Voltmeter Substitute - - - Frederic B. Fuller	54
The Stewart-Warner Series 950 - - - - - A. C. Matthews	55
Band-Pass Filter Design - - - - - E. A. Uehling	57
Radio Broadcast Laboratory Information Sheets	
	Howard E. Rhodes
No. 304. Distributed Capacity Measurements	No. 306. Advantages of Automatic Volume Control
No. 305. Distributed Capacity Measurements	

The contents of this magazine are indexed in *The Readers' Guide to Periodical Literature*, which is on file at all public libraries

. . . among other things

NOW THAT the two largest public radio shows—those in New York and Chicago—have been held, it is worth while pointing out that the exhibitions did full justice to the merchandise offered by manufacturers this year. That was to be expected, but the more interesting point is that the public did justice to the shows, too. With an astounding number of paid admissions to the shows in both cities, we have ample evidence that radio has the strongest of holds on the public. Great attendance does not mean that every buyer of "a coveted pasteboard" for admission will immediately rush to the nearest dealer and open his heart and checkbook. But it does mean that dealers can be certain that they do not lack for prospects.

IT MAY BE observed in a still small voice that may be heard through the current verbal sales excitement about screen-grid tubes and their good works that the use of these tubes is also responsible for the greatly decreased a.c. hum which is an important but not much-stressed feature of this year's models. Screen-grid tubes properly used mean plenty of r.f. amplification, and plenty of amplification before the detector means that only one audio stage is required. And less amplification in the audio side means decreased hum. The hum is no longer a serious problem of the sales groups and the designers have been freed of these worries by this unexpected benefit of the proper use of this tube.

THOSE WHO are interested in trends—and who isn't?—will find our summary of exhibits at the New York show and its comparison with exhibits at the earlier Trade Show of interest and probably considerable use.

COMING ISSUES will contain a variety of articles of use to those who sell radio. These will discuss such subjects as the future of the jobber, where trouble is apt to develop in house-to-house selling, how a successful merchant manages his sales staff, the present trend in time-payment selling, how color can best be used in window display, what the dealer thinks about factory newspaper tie-in advertising, and something about the wide variety of outlets now handling radio. The engineering section will present, among many others, articles on the pentode tube, economy in power supply circuit design, a discussion of the relation between cost and permissible performance tolerances, and a design description of the Philco 95 receiver.

—WILLIS KINGSLEY WING.

TERMS: \$4.00 a year; single copies 35 cents; All rights reserved. Copyright, 1929, in the United States, Newfoundland, Great Britain, Canada, and other countries by

DOUBLEDAY, DORAN & COMPANY, INC., Garden City, New York

MAGAZINES COUNTRY LIFE WORLD'S WORK THE AMERICAN HOME RADIO BROADCAST SHORT STORIES LE PETIT JOURNAL EL ECO WEST BOOK SHOPS (Books of all Publishers)

NEW YORK: <LORD & TAYLOR, JAMES MCCREERY & COMPANY, PENNSYLVANIA TERMINAL, 166 WEST 32ND ST., 848 MADISON AVE., 51 EAST 44TH STREET, 420, 526, and 819 LEXINGTON AVENUE, GRAND CENTRAL TERMINAL, 10 WALL STREET> ATLANTIC CITY: <2807 BOARDWALK> CHICAGO: <75 EAST ADAMS STREET> ST. LOUIS: <223 N. 8TH ST. and 4914 MARYLAND AVE.> CLEVELAND: <HIGBEE COMPANY> SPRINGFIELD, MASS: <MEEKINS, PACKARD & WREAT.

OFFICES

GARDEN CITY, N. Y. NEW YORK: 244 MADISON AVENUE. BOSTON: PARK SQUARE BUILDING. CHICAGO: PEOPLES GAS BUILDING. SANTA BARBARA, CAL. LONDON: WM. HEINEMANN, LTD. TORONTO: DOUBLEDAY, DORAN & GUNOY, LTD.

OFFICERS

F. N. DOUBLEDAY, Chairman of the Board; NELSON DOUBLEDAY, President; GEORGE H. DORAN, Vice-President; RUSSELL DOUBLEDAY, Secretary; JOHN J. HESSIAN, Treasurer; LILLIAN A. COMSTOCK, Ass't Secretary; L. J. MCNAUGHTON, Ass't Treasurer



EVEREADY RAYTHEON

4-PILLAR TUBES

BRING OUT THE BEST THAT'S
IN ANY RADIO RECEIVER



THE GREATLY superior performance of new Eveready Raytheon Tubes means the very best reception a radio receiver can give. People in all parts of the country report amazing results from their own receivers since installing these marvelous new tubes. Greater distance, more power, improved tone, quicker action!

Put a new Eveready Raytheon Tube in each socket of a receiver—and note the vast improvement. Then examine one of these tubes. Observe the solid, four-cornered glass stem at the base of the elements, supporting the four rigid pillars which hold the elements. Notice how the elements are anchored at both sides as well as at the ends. Note how this 4-Pillar construction is braced still further by a stiff mica plate at the top.

The jolts and jars all tubes receive in shipment cannot distort the elements in an Eveready Raytheon. Handling these tubes and installing them cannot impair their performance. For the elements are permanently held in their correct and accurate positions by the patented Eveready Raytheon 4-Pillar construction.

No other tube can give you all the advantages of this 4-Pillar construction, for it is patented and exclusive with Eveready Raytheon. These fine tubes come to you in the same perfect condition as when they leave our laboratory test room . . . all their superlative performance intact.



Trade-marks

NATIONAL CARBON CO., INC.

General Offices: New York, N. Y.

Branches: Chicago Kansas City
New York San Francisco

Unit of Union Carbide  and Carbon Corporation

THESE INTERESTING TUBE TESTS ARE FEATURED IN ARCTURUS SATURDAY EVENING POST ADVERTISING



There's no question about Arcturus' 7-second action when your customer holds the watch.



A two-minute demonstration of Arcturus' clear, humless tone is more convincing than a twenty-minute sales talk.



Arcturus Tubes hold the world's record for long life because they withstand the line surge that burns out other tubes. Show your customers that Arcturus Tubes easily withstand 75% more current than they are designed for.

A NEW IDEA IN SELLING TUBES

THAT MEANS MORE
PROFITS FOR EVERY
ARCTURUS DEALER

137
FACTORY
INSPECTIONS
GUARD
ARCTURUS
QUALITY

THE more Arcturus Tubes you sell, the better for your business.

And the best way to sell these superior tubes is to demonstrate their many good points.

Our National Advertising Campaign, beginning with a half page in the October 26th Saturday Evening Post, tells radio set owners to *make sure* of tube performance before they buy tubes. We tell them what points to check, and how to check them. And Arcturus Dealers will be glad to make these tests, because Arcturus performance measures up to the highest standards at every point.

These photographs, reproduced from our Saturday Evening Post advertising, illustrate three easy tube tests that clinch sales. Show your customers what Arcturus Blue Tubes can do, and watch your tube sales jump.

When your Arcturus sales go up your customers get better reception and your service overhead goes down.

Try selling Arcturus Blue A-C Tubes this way, and see what happens to your tube and set sales.

ARCTURUS RADIO TUBE COMPANY
Newark, N. J.

ARCTURUS
BLUE **A-C** **LONG-LIFE** **TUBES**

THE RADIO WORLD'S FAIR

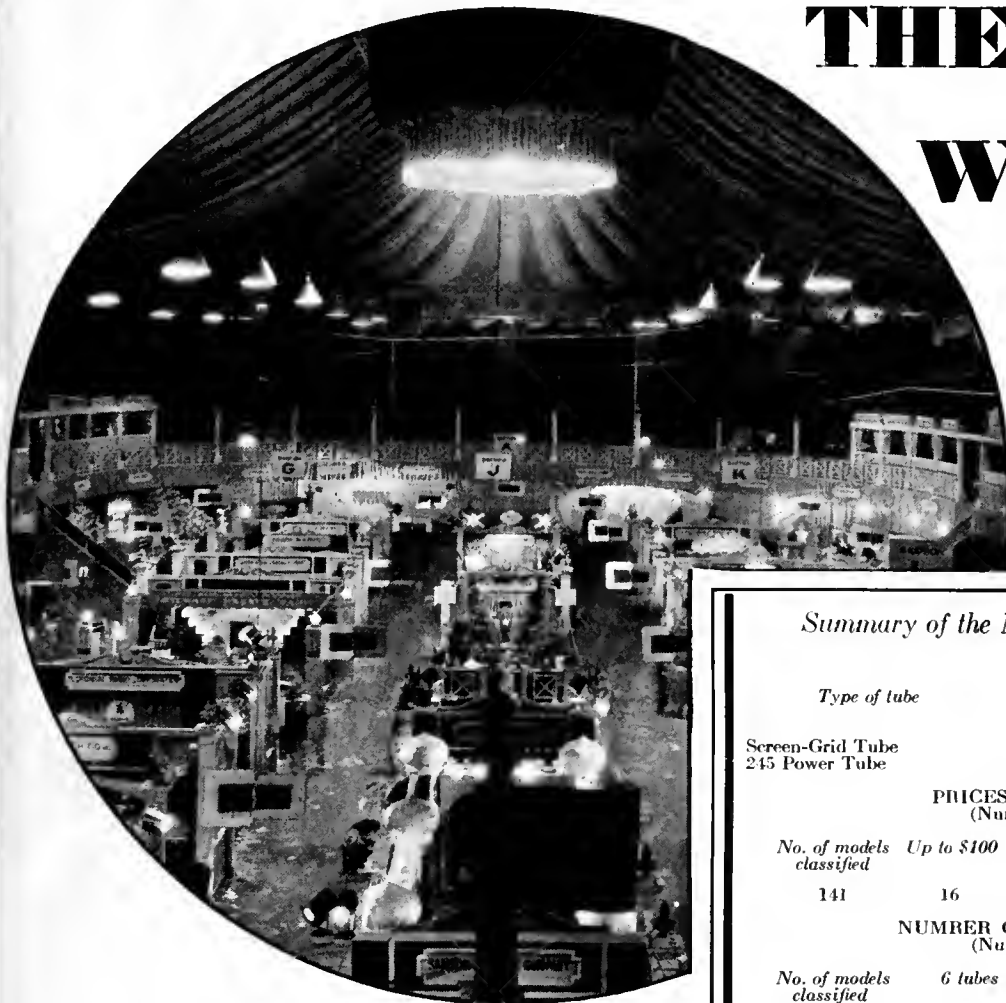

Summary of the New York Radio World's Fair

TUBES USED

Type of tube	No. of models classified	No. of models using tube	No. of models not using tube
Screen-Grid Tube	161	88	73
245 Power Tube	134	103	31

PRICES OF RECEIVING SETS (Number of models below)

No. of models classified	Up to \$100	\$100-\$150	\$150-\$200	\$200-\$300	\$300 up
141	16	27	42	34	22

NUMBER OF TUBES USED IN SETS (Number of models using)

No. of models classified	6 tubes	7 tubes	8 tubes	9 tubes or more
133	13	65	35	20

TYPES OF CABINETS

No. of models classified	No. of consoles	No. of phonograph-radios	No. of tables
139	99	20	20

LOUD SPEAKERS

No. of models classified	No. using dynaotics	No. not using dynaotics
122	114	8

POWER TUBES

No. of models classified	No. using 245's	No. using 210's	No. using 171's	No. using 250's	No. using 112's
134	103	2	14	12	3

PUSH PULL

No. of models classified	No. using push pull	No. not using push pull
129	114	15

AVERAGE PRICES OF VARIOUS TYPES

Type of receiver	Average price
All phonograph-radio combinations	\$395
All table models	\$107
All console models	\$232

tube and 73 models did not. The trend toward the more general use of the tube is shown by the fact that our survey at the Chicago show indicated the use of this tube in only 45 per cent. of the models.

2. How about prices?

At the show 141 models were classified. Sixteen were priced at less than \$100, 27 at from \$100 to \$150, 42 at \$150 to \$200, 34 at \$200 to \$300, and 22 at more than \$300. Sixty per cent. of all the models listed at \$200 or less. At the Chicago show 65 per cent. listed at \$200 or less so, in general, there hasn't been any definite change in price trends since June when the Chicago show was held. Table model prices do, however, average somewhat

An Analysis of the New Receivers Displayed at the Radio Show at the New Madison Square Garden, New York City.

A SUMMARY of the exhibits of receiving sets at the New York Radio World's Fair has been made by RADIO BROADCAST. The results are presented here in the hope that they will be useful to the entire trade. A similar survey was made of the exhibits at the Chicago Radio Trade Show last June and was published in RADIO BROADCAST for July, 1929. Comparisons between the two exhibits are somewhat difficult, due to the fact that exhibitors at the two shows were not exactly alike either in number or in name. The purpose of this survey, however, is to summarize the salient facts and to give a general picture of the industry's present offerings of radio sets.

Our summary shows—in figures—what the trade in a general way knows: the console model still rules supreme, the dynamic loud speaker is on top of the heap, there is a wide range of offerings in the medium-price field, the phonograph-radio combination is returning to favor, screen-grid models predominate, and prices are, on the average, only a little higher. Two tables show in compact form what the offerings to the trade and public are and how they compare with the first-season offerings at the Radio Trade Show in June.

1. How about screen-grid models?

Somewhat more than half of the models at the show used the screen-grid tube. Of 161 models, 88 sets (55 per cent.) used the

higher, the average at the New York show being \$107 and at the Chicago show \$80.60. But, with some 60 per cent. of all models at \$200 or less, the buying public will have a wide choice of moderately priced, well-designed radio sets.

3. Tables, consoles, or combinations?

Consoles quite definitely. Of the 139 models classified, 99 receivers (71 per cent.) were consoles, 14 per cent. were tables, and 14 per cent. were combination radio phonographs. The buyer now gets a "swell" piece of furniture when he buys his radio receiver. Buying the set complete in a cabinet with a loud speaker also has the advantage that the manufacturer will always pick out a loud speaker that will give best results with his particular receiver, a good argument for the dealer when a customer wants to use an old already-owned loud speaker.

4. Dynamic loud speakers vs. non-dynamic types.

Dynamic loud speakers continue to run away with the field. The slight increase (4 per cent.) in receivers using non-dynamic loud speakers at the New York show may or may not be a trend. One fact is certain however—the dynamic is still, by far, the most popular loud speaker.

5. How much power will the September buyer get?

At the Chicago show 77 per cent. of all models analyzed used the 245-type power tube. Exactly the same percentage held for the models analyzed at New York. Since the majority of these receivers used two of the new power tubes, the average user will get at least 3.0 watts (if he wants it) from his radio, or about three times that obtainable from sets of a year ago which used a single 171 tube. No wonder New York is considering laws to regulate the amount of noise (unwanted radio music) which anyone can thrust upon the neighborhood air.

6. How do push-pull and single tubes compare?

Only 1.5 per cent. of the sets analyzed at Chicago used single tubes in the power stage. At New York there was a decrease in percentage of models using push pull (one company alone had some ten models none of which used push pull.) Does this mean that set designers are finding single audio stages are as quiet with single tubes as they are in push pull? Or that (as is true) the average person cannot tell the difference between the output of a single tube compared to that obtainable from push-pull tubes?

7. Have prices changed since June?

There has been no change in the average price of console models, which nearly everyone buys (or sells). Table models seem to be somewhat higher, and phono-radio combinations are as expensive as ever, the average being \$395.

8. How many tubes do the sets use?

Sets are using fewer tubes. Models using 7 tubes or less made up 59 per cent. of the exhibits at the New York show and only 33 per cent. at the Chicago show. Here, apparently, is a definite

trend towards the use of fewer tubes—due possibly to the effect of the screen-grid tube which gives some three times as much amplification as from ordinary tubes. At the New York show, 133 models were classified and 13 used 6 tubes or less, 65 used 7 tubes, 35 used 8 tubes, and 20 used 9 or more tubes.

9. What about d.c. and battery-operated sets?

Out of 141 models on which data was obtained there were 13 of the d.c. and battery-operated types. The industry has put most emphasis on the a.c. set, but indications are that the d.c. set will soon get more attention—which it certainly deserves.

Some consolation may be had from the fact that only 9 such sets were exhibited at the Chicago show whereas 13 were shown at the New York Radio World's Fair.

10. What are the special features?

The use of screen-grid tubes must be classed as the major feature which radio receivers boasted at the September show. There were also other features which time will probably bring into even greater prominence. These are automatic tuning, remote control of tuning, phonograph jacks, automatic control of the voltage into the receiver (line-voltage control), tone-control knobs which enable the listener to remove high or low audio tones if desired—as when static is bad—greater use of local-distance switches, linear and power detection, single stage audio amplifiers, humless amplifiers, illuminated tuning dials, and other dials in which the entire scale is always visible.

11. What does the customer get?

If the models exhibited at the show indicate the trend in the public's buying, most of the sales will be consoles—table models are in the minority. An average console model receiver costs \$232 and includes, almost invariably, a dynamic loud speaker, push-pull 245-type power tubes or tubes of even more

power output, a sensitive and selective tuning system. The table models cost about half as much as a console, i.e., \$107, and have everything the consoles have except the special features which go with the latter type of set, such as loud speakers, etc. The table model purchaser buys, or owns, a separate loud speaker. The table set will be more selective and more sensitive than sets of a year or more ago.

If the purchaser wants the best of modern radio, he will buy a combination phonograph-radio set which will cost him, on the average, about \$400. It will include a dynamic loud speaker, the power output of push-pull 245-type tubes or more power output if desired, and space for records with which to while away the time when there is no (or no good) broadcasting.

No matter what type of receiver your customer buys, this year he receives more value for his money than he did last year. Sets are not only generally better, giving improved sensitivity, selectivity, and fidelity, but prices on the average are lower than a year ago. Prices vary from a low limit of about \$50 to an upper limit of about \$2500—there is a radio set to fit every pocketbook.

<i>Comparison of Chicago and New York Shows</i>												
TUBES												
Type of tube	No. of models classified		% using tube		% not using tube							
	CHICAGO	N. Y.	CHICAGO	N. Y.	CHICAGO	N. Y.						
Screen Grid	215	161	45.5	55	54.5	45						
245 Power	202	134	77	77	23	23						
PRICES OF RECEIVING SETS												
No. of models classified	Up to \$100		\$100-\$150		\$150-\$200		\$200-\$300		\$300 up			
	No.	%	No.	%	No.	%	No.	%	No.	%		
Chicago	212	36	17.	36	17.	66	31.	45	21.	29	14.	
New York	141	17	11.	27	19.	42	30.	34	24.	22	16.	
NUMBER OF TUBES USED IN RECEIVERS												
Number of models classified	6 tubes		7 tubes		8 tubes		9 tubes or more					
	No.	%	No.	%	No.	%	No.	%				
Chicago	190	18	10.	44	23.	77	40.	51	27.	27.		
New York	133	13	9.	65	49.	35	27.	20	15.	15.		
CABINETS												
No. models classified	Consoles		Table		Phono-radio							
	No.	%	No.	%	No.	%						
Chicago	219	166	76.	32	15.	21	9.					
New York	139	99	72.	20	14.	20	14.					
LOUD SPEAKERS												
No. of models classified	Dynamics				Not dynamics							
	No.	%	No.	%	No.	%	No.	%				
Chicago	215	209	97	6	3							
New York	122	114	93	8	7							
POWER TUBE TYPES												
Nn. of models classified	245's		210's		171's		250's		112's			
	No.	%	No.	%	No.	%	No.	%	No.	%		
Chicago	202	156	77	26	13	16	8	4	2.0			
New York	134	103	77	2	1.5	14	10	12	9	3	4.2	
PUSH PULL												
No. of models classified	Push pull				Not push pull							
	No.	%	No.	%	No.	%	No.	%				
Chicago	202	199	98	3	2							
New York	129	114	88	15	12							
AVERAGE PRICE OF VARIOUS TYPES												
Type of receiver		Average price										
		Chicago					New York					
Table Model						\$ 80.60					\$107.00	
Console						240.00					232.00	
Phonograph-Radio											395.00	

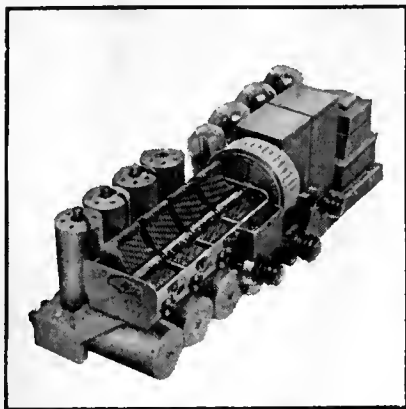

COURIER MODEL 65

This chassis is made by the United Reproducers Corporation. It uses three screen-grid tubes, power detection, and a combination of resistance- and transformer-coupled audio amplification. All the condensers rotate in ball bearings.

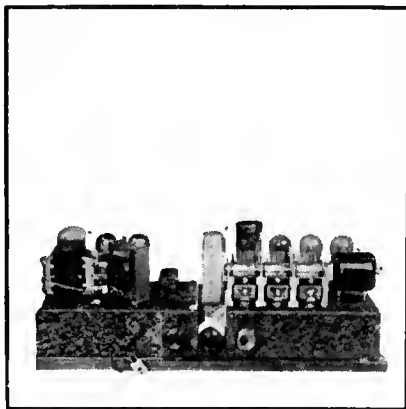

EVEREADY SERIES 30

The shields over the tuning condensers and transformers were removed when this picture was taken to show compactness and accessibility of transformers, condenser drive, and variable condenser. The antenna circuit is tuned by the variometer at the extreme right.

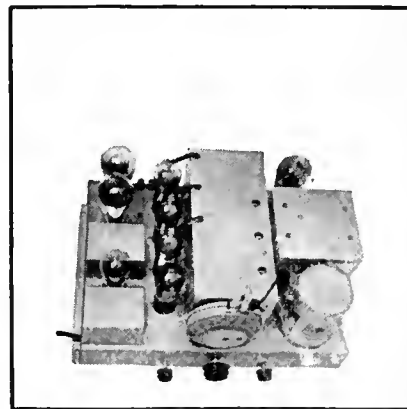

AMRAD RECEIVER

An example of a well-designed chassis assembly. Three screen-grid tubes are used in the radio-frequency stages and in the audio output are two 245-type tubes in push pull. In the filter circuit is a Mershon condenser, a "self-healing" electrolytic filter unit.

NINE NEW CHASSIS DISPLAYED

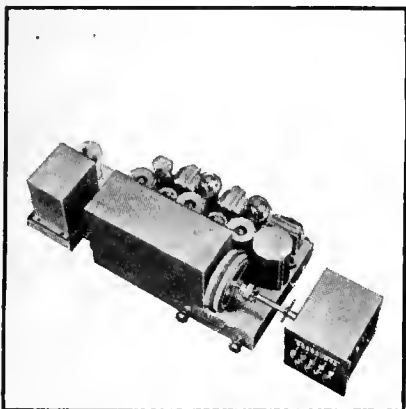

ZENITH SERIES 50

Double push-pull audio amplification is used in this receiver in combination with a new twelve-inch dynamic loud speaker. At the right is the well-known Zenith feature, the automatic tuning device. "Press the button and there's your station."

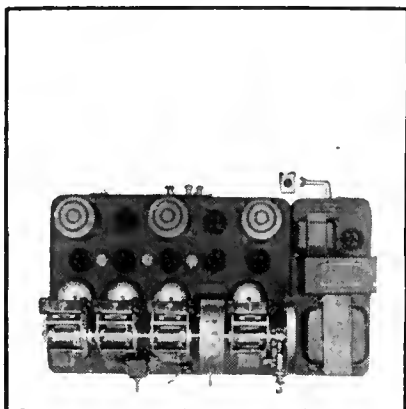

FADA MODEL 35

Features of this receiver are band-pass tuning circuits, screen-grid tubes in the r.f. amplifier, two 245-type tubes in push pull in the output. Note that the tuning dial is not only marked in degrees but also in kilocycles and wavelengths.

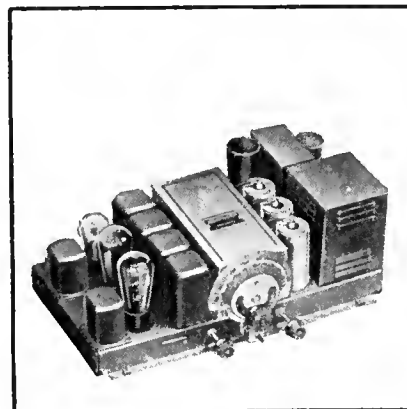

STEWART-WARNER SERIES 900

In this chassis are found the following interesting features: power detector circuit, resistance-coupled audio-frequency amplifier, three screen-grid radio-frequency stages. Varying line voltage is compensated automatically by means of a line-voltage control.

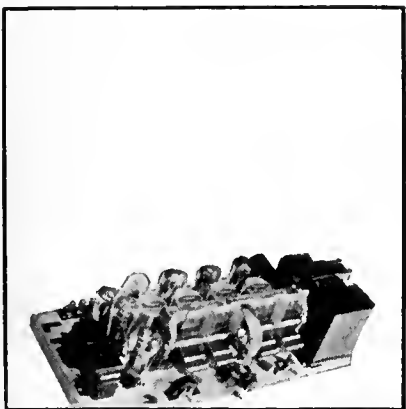

PHILCO CHASSIS

An eight-tube a.c. neutrodyne receiver with tuned antenna input followed by three stages of radio-frequency amplification using 226-type tubes. One of the line of Philco "Neutrodyne-Plus" receivers manufactured by the Philadelphia Storage Battery Co.

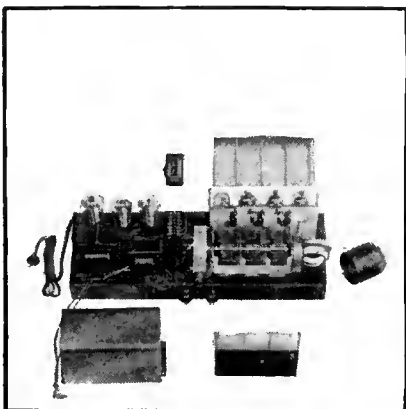

BOSCH MODEL 48

Three screen-grid radio-frequency stages, a linear high-voltage detector, and a single audio-frequency stage employing two 245-type tubes in push pull are employed in the new Bosch receiver. In the above picture all shields have been removed.

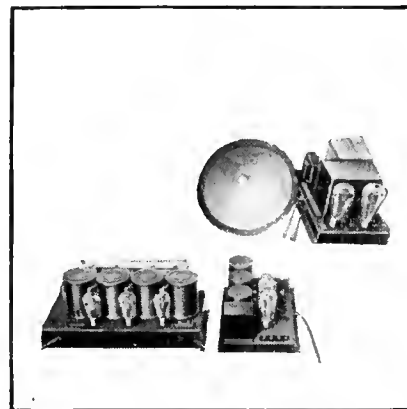

KOLSTER MODEL K-14

This picture illustrates a dismantled chassis to show the various sections. At the left is the receiver, and above is the loud speaker and the power supply. The a.f. amplifier is not shown. The set uses three screen-grid tubes in the r.f. stages and a 245 in the output.

AT THE RADIO WORLD'S FAIR



Let's Look at Radio's Largest Year

By **T. A. PHILLIPS**

Manager, Research Division, Doubleday, Doran & Co., Inc.

JULY							AUGUST				SEPTEMBER								
3	4	5	6	7			1	2	3	4						1			
10	11	12	13	14	5	6	7	8	9	10	11	2	3	4	5	6	7	8	
17	18	19	20	21	12	13	14	15	16	17	18	9	10	11	12	13	14	15	
24	25	26	27	28	19	20	21	22	23	24	25	16	17	18	19	20	21	22	
31					26	27	28	29	30	31	23	24	25	26	27	28	29		
OCTOBER							NOVEMBER				DECEMBER								
2	3	4	5	6			1	2	3									1	
9	10	11	12	13	4	5	6	7	8	9	10	2	3	4	5	6	7	8	
16	17	18	19	20	11	12	13	14	15	16	17	9	10	11	12	13	14	15	
23	24	25	26	27	18	19	20	21	22	23	24	16	17	18	19	20	21	22	
30	31				25	26	27	28	29	30	23	24	25	26	27	28	29		
JANUARY							FEBRUARY				MARCH								
1	2	3	4	5					1	2								1	2
8	9	10	11	12	3	4	5	6	7	8	9	3	4	5	6	7	8	9	
15	16	17	18	19	10	11	12	13	14	15	16	10	11	12	13	14	15	16	
22	23	24	25	26	17	18	19	20	21	22	23	17	18	19	20	21	22	23	
29	30	31			24	25	26	27	28	24	25	26	27	28	29	30			
APRIL							MAY				JUNE								
2	3	4	5	6			1	2	3	4									1
9	10	11	12	13	5	6	7	8	9	10	11	2	3	4	5	6	7	8	
16	17	18	19	20	12	13	14	15	16	17	18	9	10	11	12	13	14	15	
23	24	25	26	27	19	20	21	22	23	24	25	16	17	18	19	20	21	22	
30					26	27	28	29	30	31	23	24	25	26	27	28	29		

THREE MILLION receivers were sold in the year between July 1, 1928, and July 1, 1929, a figure never before exceeded in the history of radio. To the 38,500 dealers who participated in this extraordinary sale, the figure itself is exceeded in importance by only one fact, and that is this—these dealers who turned over three million receivers purchased only 94,000 more sets than they sold, an average individual excess of purchase over sale of less than three sets.

The high quarter in this year (1928) was, as is to be expected, October, November, and December. In this period 1,177,916 sets were sold followed by 798,813 in the next three months, i.e., January, February, and March of 1929. The low quarter was April, May, and June when a total of only 553,550 sets was disposed of, but this figure is half of the number sold in the best period, showing that the wide divergence between the good season and the bad no longer exists.

How Dealers' Stocks Changed

During 1929, stocks in dealers' hands increased over the same periods of 1928. In the period ending January 1, 1929 (including October, November, and December, 1928) the same amount of stock was in the hands of the dealers as existed at the end of the three-month period including October, November, and December, 1927 (actually it was 0.5 per cent. less, a negligible figure). In the next three-month period, however, dealers' stocks of sets were 24 per cent. greater than in the year before and at the end of the next quarter

(April, May, and June, 1929) these stocks were 31 per cent. greater than at the end of the same period the previous year.

Dealers' Purchases by Quarters

Table I gives, for the first time, figures showing the indicated purchases of sets by dealers in each of the three-month periods covered by this survey.

Table II contrasts the situation on the dealers' shelves for the years 1929 and 1928. Although inventories tended to decrease in 1928, they increased in 1929, each period showing an increase over the one previous. This may indicate that at the beginning of the three-month period, July to October, 1928, dealers were generally overstocked with receivers, a fact which is partially borne out by the excess of sales to purchases in the months of October, November, and December, 1928. Abnormal stocks naturally slowed up purchases of new stocks, but this increase in sales over purchase is also due to the fact that these three months were in the half year when set sales are at their peak.

Purchases of receiving sets by dealers in the last three months of the 1928 radio year, i.e., April, May, and June, 1929, were not much in excess of sales by dealers; the data in Table I shows that dealers had disposed of 98 per cent. of their purchases, an obviously excellent situation. During this period dealers were evidently exercising caution in their purchases; in spite of this caution, however, the entire year showed that the improvement in ratio between purchase and sales was not sufficient to reduce inventories materially. The figures for the April, May, and June, 1929, period would seem

to show that even though dealers cut their purchases tremendously, their inventories increased over the preceding three months (January, February, and March, 1929). One conclusion from this fact is that the seasonal decline in set sales for April, May, and June of 1929 was more pronounced than usual.

Sales of sets during this so-called "bad" season were almost a quarter of a million less than the previous months (January, February, and March, 1929) and about 600,000 less than the last three months of 1928. The latter period, however, accounted for a total sale of 1,177,916 radio receivers.

Dealers showed a bearish attitude toward new purchases during the quarter ending on January 1, 1929. Evidence indicates that dealers are more closely regulating their commitments. In the months of April, May, and June, of 1929, for example, sales dropped 40 per cent. under the preceding three months, dealers purchases receded 45 per cent., and, as already pointed out, the dealers sold 98 per cent. of their purchases. This indicates, probably, that dealers in general were doing everything in their power to improve their inventory status.

The data for the entire radio year suggests some interesting conclusions. First, sales were higher than ever before. Secondly, dealers have become more cautious in their purchases of sets. Thirdly, inventories progressively increased from January, 1929, to June, 1929.

It must be pointed out, however, that while small inventories are temporarily fortunate, they do not press the dealer to get out and sweat for new sales as he would be forced to do if his inventory were larger. If the dealer is doing his level best to sell the merchandise he now has, however, it may be fair to conclude that the present condition is for the moment healthy—for the dealer.

We cannot escape the important fact that dealers must no longer be behind-the-counter experts alone and that the dealer

who waits for trade to come into his store may wait too long. The manufacturer-jobber-dealer combination must work in closer harmony than ever before if the sales record of three million receivers per year is to be equaled or excelled. Manufacturers must consider their responsibility to the dealer greater than is required to create merely public demand by national advertising. They must map out and furnish to the dealer increasingly effective merchandising assistance. The jobber must share in this new responsibility, too.

As for the dealer—he must soberly reflect upon his sales methods of the past year, and make a conscious effort to make them more effective than before if he is to better his previous record.

The data in this article were compiled from the quarterly surveys conducted by the Electrical Equipment Division, Bureau of Foreign and Domestic Commerce, in cooperation with the National Electrical Manufacturers Association. With the report for the last quarter (which ended on July 1, 1929) summaries of dealers' sales, inventories, and indicated purchases became possible for the first time in the history of radio sales.

TABLE I—RADIO RECEIVER DATA

Quarter Ending	Inventory in hands of dealers at end of Quarter	Sales for Quarter	Indicated Purchases for Quarter	Percentage of Sales to Purchases of Sets for Quarter
July 1, 1928	297,000			
Oct. 1, 1928	422,900			
Jan. 1, 1929	334,400	573,639	698,539 (a)	82.0%
Apr. 1, 1929	385,600	1,177,916	1,089,416 (b)	107.0%
July 1, 1929	392,000	798,813	850,013 (c)	92.0%
		553,550	559,950 (d)	98.0%
Totals, July 1, 1928 to July 1, 1929	3,103,918	3,197,918		

(a) Inventories being greater on October 1st than on July 1st, dealers must have purchased MORE sets than they sold, i.e., 422,900 minus 297,000 therefore, 573,639 plus 125,900, or 698,539 sets.
 (b) Since inventories in hand of dealers were less on January 1st, than October 1st, dealers must have purchased less sets than they sold, i.e., 422,900 minus 334,400 = 88,500 (excess of sales over purchases). Indicated purchases were, therefore, 1,177,916 minus 88,500, or 1,089,416.
 (c) & (d) Same method as (a)

TABLE II—STOCK OF RECEIVERS IN HANDS OF RADIO DEALERS

Quarter Ending	1928	1929	Per cent. Increase or Decrease over same period of previous year
July	297,000	392,000	—31.0%
Apr.	309,300	385,600	—24.0%
Jan.	350,600	334,400	—9.5%
Oct.	295,200	422,900	—43.0%

*Figures estimated from quarterly survey of Electrical Equipment Division, Bureau of Foreign and Domestic Commerce with cooperation of National Electrical Manufacturers Association.

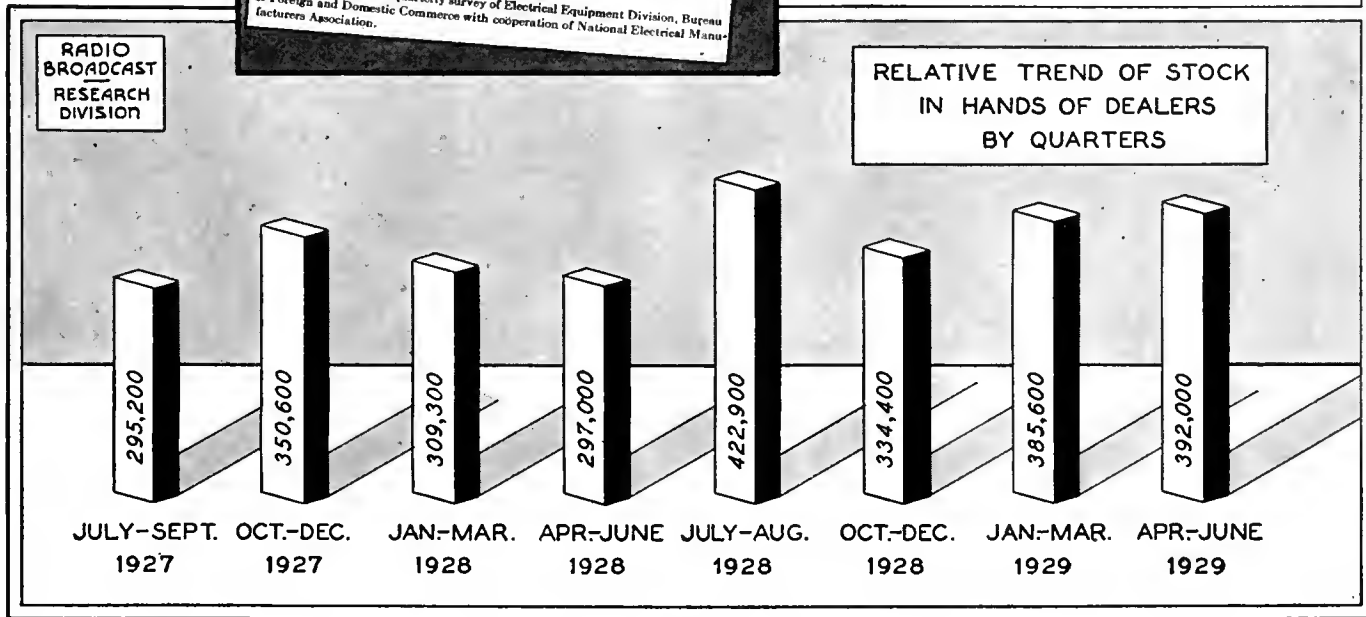
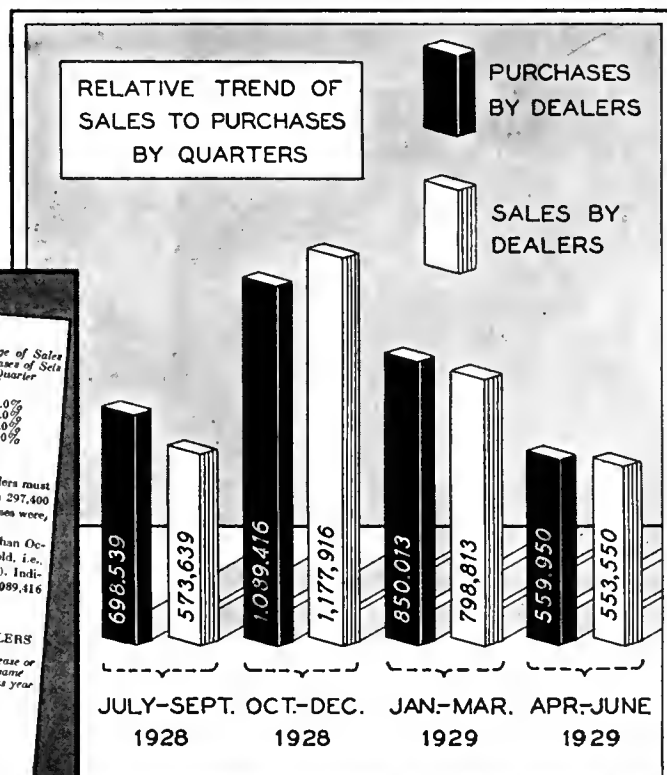

WHAT MADE THIS DEALER SUCCEED?

By EDGAR H. FELIX

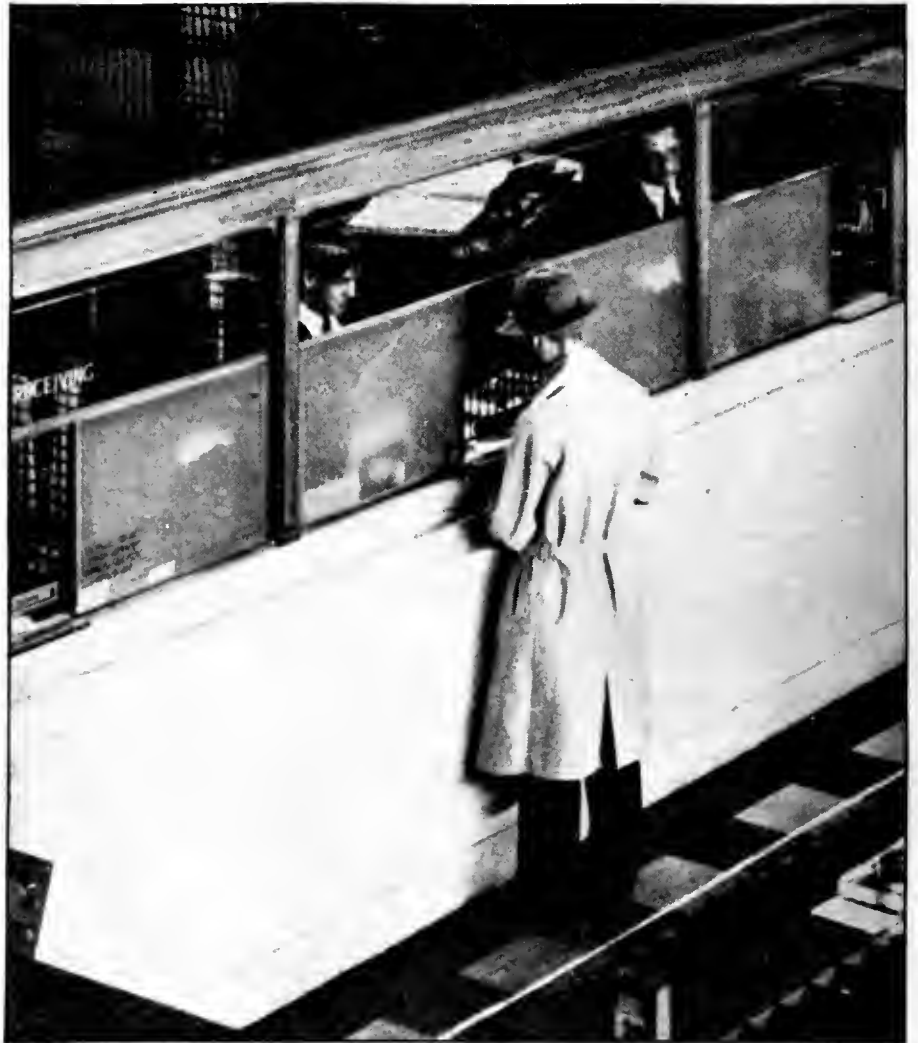

I AM CONVINCED that neither salesman nor serviceman can handle adequately more than one line of radio receivers. Since beginning business we have sold but one line of sets—a line that reaches into all price classes—and for this set we carry a very extensive line of cabinets. We understand these sets not only in general terms but technically as well. With but one line I can unhesitatingly proclaim that it is the best receiver available on the market. It is impossible to meet the demand for every set the customer is likely to ask for, and I see no objection to concentrating on a single line which will meet the needs of the customer regardless of his financial position. Also, my orders are placed through jobbers from whom I get excellent service, for they appreciate the volume of business which I give them. From a sales standpoint this policy of concentration has been entirely successful," says a radio dealer who, several years ago started in business as a custom sets builder, then to become the owner of a single radio store, and at present operating a chain of eighteen radio stores in a half dozen large cities, "The handling of but a single line of receivers is one of the cardinal principles on which the success of my business has been built."

Other Basic Principles

We might as well call the central figure of this story Smith. That is not his name. While Smith spoke freely from his experience, he was unwilling to have his name used.

The first paragraph described one of the principles on which Smith has built a successful business. But it is only one principle. Ever since his business was started Smith has kept his ear

close to the ground and displayed an ability to meet changing conditions quickly.

Smith has never used local newspaper advertising extensively. His original store was located in a small city within commuting distance of New York City and he knew it would be suicidal to try and meet the cut-price competition of the city stores. For this reason he considered it inadvisable to use the conventional advertising. To create sales he has relied mainly on two things; a careful study of store arrangement and window display and very extensive direct-mail efforts paving the way for house-to-house canvassing.

Window Displays

Utmost simplicity and dignity have always been observed in the window dressing—the windows are never crowded with innumerable items. The loud speakers over the store are the best obtainable and are always operated with the utmost attention and care to avoid blasting or any other kind of distortion.

Successful direct-mail selling is not an easy job—but Smith, after many trials, has worked it out to the point where it is responsible for a large part of his sales. In this connection it is interesting to note that for his direct-mail efforts he has generally relied on the material offered by the manufacturer of the line which he handles. His most effective direct-mail efforts have always consisted of a rapid-fire series of letters and circular matter extending over a period of about two weeks—many of the mailings being only two days apart! Timed immediately to follow the receipt of the last piece of mailing, a personal call is made by one of the Smith salesmen. This

He says—

Carry Only One Line, Use Direct Mail Advertising Followed by Salesmen, Make the Customer Come to the Store, Carry Good Side Lines, Open a Second Store When Your First Does the Maximum, Choose a Similar Location, and Experiment Unceasingly With Selling Ideas.

method of direct-mail selling has *proved* its ability to produce sales. This dealer is convinced that simple house-to-house selling is not profitable for the salesman is without introduction. However, if adequate preparation is made by a direct-mail campaign the possibility of making a sale is very much greater.

No Home Demonstrations

As part and parcel of this general scheme is Smith's policy of avoiding home demonstrations. The salesman calls on the prospect with the idea of getting them to come *to the store* for a demonstration! Two years' trial of this policy has led to a higher percentage of sales to calls made than any other method of outside selling which this dealer has tried. If after a store trial the customer insists on a home demonstration to make certain that the set will perform as well in his home as it

did in the store, the set is taken to the home, installed, and operated to the customer's satisfaction. At that time the salesman either secures an order and a deposit or the set is immediately removed.

Selling in Summer

During the slack months of the year a considerable part of Smith's revenue is obtained from side lines—well chosen items that go well in summer and which are properly advertised by their manufacturers. Smith's side lines have also been chosen with an eye for what his sales staff can sell. He carries a large line of electric clocks and home motion picture cameras and supplies. He has found that his salesmen were able to sell these products and that the shelf and display space to be had in his store was suitable for these items. He is seriously considering electrical refrigeration also, but his present delivery equipment is not suited to heavy merchandise.

While on the subject of summer sales it should be pointed out that Smith does not subscribe to the intense effort of the radio industry to increase summer sales by increasing sales pressure. That increased sales pressure, he states, involves increased cost per sale and therefore represents a profit only to the manufacturer. Smith is in the radio business to make money for himself and if, in so doing, he incidentally makes money for others, he has no objection. But he will conduct no business activity of an intensive character in a manner which does not make money for himself.

As a result of these policies, Smith's business grew rapidly. A second store was opened and the same principles which had proved so successful in the first store were carried out. To-day

Smith operates a chain of stores in half a dozen large cities—and in all cases the stores are operated on the same essential principles that had been put through the fire and proved their worth. The same policies could be used effectively in every case because Smith always made sure that the stores which he opened were located in communities similar in character and population to that surrounding his first store. Sometimes a new store was opened, sometimes a well-located existing store was bought out.

In connection with opening a new store, the location is not the only thing to be considered, Smith points out. For example, as Smith's chain grew he considered it desirable to have an outlet in a certain prosperous community. However, after an investigation of conditions he found two very competent dealers serving the territory and concluded that an additional store would simply reduce the profits of all concerned. Then, after extensive negotiations, he was unsuccessful in buying or merging with either of these stores. So, illogical as it may seem, he does not sell radio in the most prosperous community of the entire territory that his chain serves.

To the average reader the example cited above may sound like an unusual practice for a chain store, as, in other fields, such as grocery, drug, etc., chain stores frequently plunge into intense competition and, through a long period of price cutting, succeed in winning over customers of the long-established neighborhood stores. This method has also been employed in some instances by growing radio chains but, in Smith's opinion, it is financial suicide. The radio buyer's initial purchase is his most important one and, if that is not made at a profit to the dealer, there is little opportunity of making that customer profitable to him later on.

Business Management

In Smith's chain each store has its own manager. Direct-mail campaigns are conducted from offices in the parent store. New sales ideas are tried out in individual stores and are either discarded, if they don't prove in, or, if successful, are used by all the stores. Says this dealer, "Continuous experiment with selling methods is essential. I make a trial of window displays, direct-mail campaigns, side lines, and personal selling presentations at one store or another. The experiment then effects the operation of but one outlet. This method was employed for example in working out the summer side lines which have rounded out our sales curve in a very satisfactory way. My sales experiment work will never be completed. But one conclusion which I have reached, after selling millions of dollars worth of radio sets and faithfully applying scientific methods of analysis to determine the cost of sales of every class of item I carry, is that an *exclusive* radio outlet cannot succeed in the average small community. Radio must be supplemented by other speciality products."



SERVICE-

**do you or
your customers
pay?**

By JOHN S. DUNHAM

Q R V Radio Service, Inc.

The Service Department of a Successful New York Dealer Operates at a profit Without Any Aid from the Sales Department. A Charge Is Made for Installations, Free Service Is Limited to Ninety Days, Parts are Sold at List Prices, Service Labor Is Charged for at a rate of \$2.50 per Hour, and the Customers Are Pleased!

IN ORDER to make his service department pay a profit the radio retailer must charge for service at a rate not less than two and one-half times the net cost of the labor, free service must be limited to ninety days, and list prices must be charged for all parts and accessories sold on service calls. This basic principle has been strictly adhered to by a large and successful dealer in the New York metropolitan area and it has been largely responsible for permitting the service department of this dealer's organization to pay a profit without any aid from the sales department.

This dealer employs the highest class service personnel obtainable, pays high wages, and endeavors to give the utmost in satisfactory service to the customer. His customers understand thoroughly at the time of sale that there is a definite limit to free service, and he has found by experience that after the free period they are quite willing to pay good prices for the really excellent service he provides. He sells sets, without cutting prices on *any* items, in a city which is the largest and worst hot-bed of price cutting in the country, and is making a huge success doing so, *because he renders superlative service* and charges fair prices for that service. And there are a few others, in the New York area and scattered over the country, who are doing the same thing. When the average dealer wakes up to the fact that the individual radio user *wants* good service and is willing to pay a good price for service which *is* good, and that knowledge causes the dealer to give good service and charge for it, then, and then only, will he begin to make a justifiable return on his investment in the radio business.

Before radio broadcasting became prominent, this particular dealer had made a success selling other musical instruments.

Now he has built up a successful and rapidly-growing radio business which was large enough last year to keep busy an outside service force which averaged about ten men. It is worthy of note that only one make of radio is sold. Installation is charged for at a price which permits the best of antenna equipment and a *real* job of installing, with something left over to help take care of the free calls during the ninety-day period. The installation charge is added to the *list* price of set and equipment, and is credited to the service department. The cost of the free service given is *not* charged to sales, but is entirely borne by the service department. *None* of the items of service cost is charged to sales, thus relieving the sales department entirely of that usual item of selling expense. And the reason no service has to be charged to sales in that organization is simply that *the service department operates at a slight profit.*

The way in which every radio dealer's service department may be operated at a profit will be considered in greater detail in this article. However, first we will review briefly the mistakes made by the average radio retailer, who, in common with the average retailer in other lines, is without any definite knowledge of the cost of operating his various departments; that is, the accounting system employed is not sufficiently detailed to show exactly where loss is being experienced or where a profit is being made. In this connection it has been our observation that the cost of rendering satisfactory service is usually the most neglected item, and that most of those who embark in the enterprise of making their everlasting fortune by selling radio receivers actually lose money because they underestimate the cost of service. This is not only true of dealers who have just entered the radio business but also of many of those who have had years of experience.

In addition to those dealers who have not discovered the true cost of providing good service there is another class, probably the largest, who have discovered that good service costs a lot of money, but who are of the opinion that their customers will not pay for good service and that free service *must* be given in order to satisfy them. This type of dealer usually makes one of two mistakes, both of which are equally disastrous. One is giving a great deal of free service in an attempt to keep customer good will and charging this expense to sales, at the same time trying to keep the cost of the service as low as possible by hiring inexpensive servicemen. The other course which is often followed by the dealer who is afraid to charge an honest rate for good service is to perform only the very minimum of free service which is necessary during the guarantee period and attempting to reduce the cost by hiring inexperienced high school boys for the purpose.

The fact that every dealer must learn in order to be successful is that the public is willing to pay for good service at a rate which will permit the dealer to make a profit, but when they pay a high price for service they demand the best, i.e., the customer must be more than satisfied. However, before discussing the way in which to make a service department pay, the mistakes made by the two types of dealers described above will be considered.

In the first place it has been proved again and again that it is not possible to reduce the cost of service by hiring inexpensive, inexperienced men; more competent men earn their higher wages by doing the job well the first time and reducing repeat calls to a minimum. Secondly, the dealer who gives a great deal of free service increases his overhead to such an extent that it becomes nearly as great, and in some cases greater, than the gross profit on a sale, so that the net profit either shrinks to very small proportions or disappears entirely. On the other hand, the dealer who performs only the minimum service necessary during and after the free guarantee period experiences a large loss of customer good will with the result that the business does not grow or the cost of getting the large number of replacement customers runs the overhead up to a prohibitive degree.

Making Service an Asset

The ways in which service can be made a very real asset, from all standpoints, to every dealer, may be grouped under three general headings. First, the rendering of good service. Since we have been harping on this particular subject in

RADIO BROADCAST for the past eight months, this phase should be given some well-earned rest, and we shall simply review the subject by mentioning a few of the high spots. Good service requires high-class personnel, both outside and inside. That means the employing of only grade A servicemen, as rated by some members of the F.R.T.A. and by the Radio Service Managers Association in New York, except that lower grade men may be used successfully for installing receivers under proper supervision. It requires a contented personnel, deeply imbued with personal interest in success of the primary

objective of *satisfying* the customers of the organization. It requires promptness in rendering service, the best outside and inside equipment available, complete and carefully kept records, and intelligent experienced management.

Secondly, the cost of giving such service must be accurately and constantly known. We shall discuss that anon. Thirdly, when good service has been developed, and its cost has been definitely determined, then free service must be rigorously limited to ninety days, or less; customers must be made to understand the service guarantee thoroughly before they purchase the set, all service performed after the free period must be charged for at a rate which is a mark-up of not less than 150 per cent. of the cost, or in other words, two and one-half times the cost, and all accessories and parts sold on service calls must be sold at list prices. All of that sounds rather idealistic and not very practical, doesn't it? But every bit of it is practical, and can be put into practice by every single

dealer in the United States who is not yet making the most of his service possibilities. The proof of the goodness of a pudding is in the eating of it. The proof of the practical value of the three essentials of service outlined above is the fact that they are all a part of the policy of the most successful radio dealers in the country, and the additional fact that no dealers in the country who have disregarded those three fundamentals of good business—which were learned by other industries before radio broadcasting existed—have been able to make a lasting success!

Cost Accounting

There are a great many different items which enter into the cost of performing service. If all the expenses relating to service are not kept separate from sales and other expense accounts then no way exists of ascertaining accurately the cost (Concluded on page 60)



What Does Service Labor Cost?

(Average per man of eight men over period of two years)

Pay—\$42.10 per week × 52 (weeks)	\$2189.20	per year
Insurance—Workmen's Compensation, Public Liability, Automobile Contingent Liability, and Fidelity Bond	85.48	“ “
Total Cost, per year:	2274.68	
Number of days in year	365	per year
Number of days of absence—Sundays and Holidays, vacations, sickness, Saturdays in July and August, and miscellaneous	84	“ “
Total working days:	281	“ “
Total working hours—281 (days) × 8 (hours)	2248	“ “
Labor Cost, per working hour—2274.68 (dollars) divided by 2248 (hours)	\$1.01	
Charge to customer for labor, per hour	2.50	
Inefficiency of labor—time lost out of each working hour because of wide fluctuation of service work, and other causes, 11 per cent. of \$2.50	0.275	
Maximum charge against customer for working hour	2.225	
“Free calls,” and no-charge return calls made for all reasons, 24 per cent. of \$2.225	0.535	
Actual income from labor, per working hour	1.690	
Cost of labor, per working hour	1.01	
Gross Margin on labor	0.68	
Gross Margin percentage	40.2%	



TESTED SALES IDEAS

A Method of Securing New Prospects

Operating in Minneapolis, where competition in radio is keen, we have enlisted the services of our present customers to secure new prospects. We have distributed to our entire clientele an elaborate premium book, with which goes a letter pointing out that our increased sales volume has come directly from the customers who recommend us and our product to their friends. The book shows a large variety of premiums, including electric clocks, heaters, bridge lamps, tables, and smoking stands, and explains that these articles can be obtained without charge. All our customer has to do is inform us of any of his friends who are considering the purchase of a set. If we sell the prospect within thirty days after the lead, our customer can choose any of the premiums listed as his reward. This plan is bringing in excellent results in sales and is proving a splendid good-will builder.

JOUNSON BROTHERS, Minneapolis, Minn.

The Gas Station is a Prospect

Our territory has more than the usual number of roadside gasoline filling stations and we decided to make calls on all of them to see whether or not they were equipped with radio sets. Our survey disclosed that out of 30 filling stations, only twelve had sets. Five of the stations "had been looking around" preparatory to buying a set while the other thirteen were real prospects. It did not take us quite one working day to call on all the filling stations and to talk to the owner. Repeat calls on the thirteen prospects and the five who were considering buying a set brought us a total of ten sales. We sold two of the five who had been looking around and lost three to another dealer who had shown his line. Gross sales, however, were \$1575.00 for a few days' work.

OSCAR BLONDON

A Novel Sales Stunt

C. B. Larson, a radio dealer in Virginia, Minnesota, recently inaugurated a brand new "stunt" along sales promotion lines—a slant that probably has never been touched.

Proceeding from the idea that more and more people are becoming interested in the stock market, due to its rather startling activity during the past year, Mr. Larson conceived the idea of having his bookkeeper take the stock reports over the radio at morning, noon and closing time and paste the reports in the window immediately. In addition his advertising has carried announcements of the novel service.

Mr. Larson says that it has kept his window in the public's attention and that his radio sales show very definitely its

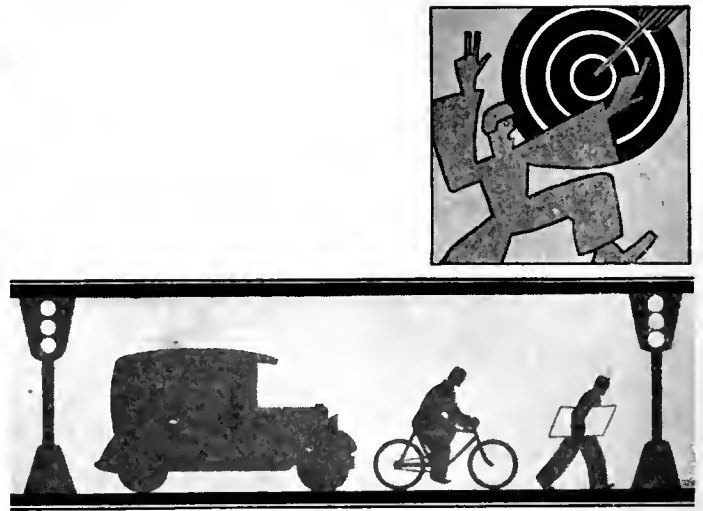

These Pages Will Serve Each Month as a Clearing House for Merchandising Ideas of Proved Value Which Are Presented in a Concise Form. This New Department is one Which Every Dealer Will Find of Definite Value

value as an attraction and business getter.

Persuasive Display

Meier Wolf and Sons, the principal furniture store in Mason City, Ia., recently celebrated the opening of their radio department. To bring this department to the immediate attention of the entire city, they arranged a campaign which tied in with the building feature which is being conducted by many large newspapers throughout the country, the model home.

A series of displays, each representing an average dwelling was constructed along one side of the store. And in each living room, a radio was displayed prominently.

An Automobile as a Radio Sales Builder

An automobile rigged up with a battery set and loud speaker together with a double-sided sign, extending from one end of the top of the car to the other has been responsible for a large share of the A-K sales of a South Haven, Mich. dealer. He says:

"When I decided to press my car into active sales-promotion efforts, I knew that the set selected had to be a reliable performer, the arrangement had to be neat, and the sign had to





GIVE US YOUR SALES IDEAS

These pages will be a regular feature of *Radio Broadcast* where we shall present ideas, both big and little, which are of proved service to dealers. If you have a pet sales idea, a stunt that produced results for you, tell us about it. *Radio Broadcast* will pay \$5 for each contribution used. A letter will describe the idea, a rough pencil sketch or photograph will help illustrate it and we shall do the rest. If you have a pet sales idea, send it in. Address Merchandising Editor, *Radio Broadcast*, Garden City, New York.

cent. between the cost of advertising and sales and showed the value of coöperation with general factory advertising.

H. SCHIRESON,
Schireson Brothers,
Los Angeles, Cal.

Making Newspaper Advertising Work

An Iowa dealer is a firm believer in regular newspaper advertising to move his radio line. A. A. Stoker, manager of the Franc Furniture Company in Davenport is speaking. He says:

"During the past year, we have developed a very satisfactory set business through no other selling medium than the newspaper. We use considerable display on our ads and our proposition is clearly stated and not misleading. Our sets are priced complete, which includes a \$5 aerial and installation charge and a \$5 carrying charge on time accounts. We feature terms because we are an installment house. We insist on a down payment of at least 13 per cent. and the balance may be paid in eight monthly installments. The down payment must be in our hands before the set is delivered, even if it is only a demonstration. If the set is not sold, we refund the customer what he has paid less \$5, the charge for erecting an aerial.

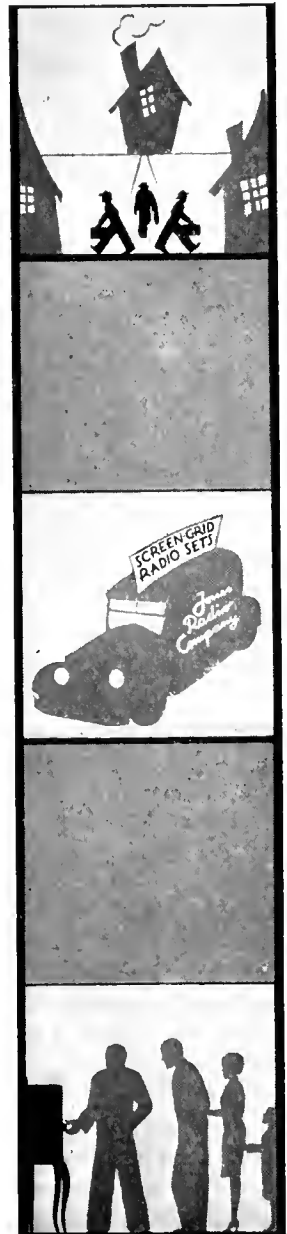

carry a pointed forceful message. The very fact that the car has attracted such favorable attention and has directly resulted in actual sales proves my three qualifications were actually met. I use the car for all my demonstration and service calls and so obtain, as nearly as possible, full-time coverage. Here is the 'meat' of the message on the two sides of the sign: 'Atwater Kent screen-grid radio—The purpose of a radio tube (aside from detection) is to amplify or increase—a radio tube that increases amplification tremendously and at the same time improves tone quality makes a better set: that is what screen-grid radio does.' And on the reverse side: 'Tremendous amplification at the rate of 60 times for each tube. Old style tubes at the rate of 10 times each, elimination of a.c. hum, etc.' When such a message is constantly impressed on prospect's minds, it finally sinks in and creates demand. I, at any rate, have found it to be true and the black side of my books justify my automobile promotion plan."

CHARLIE IVERSON, Iverson Brothers,
South Haven, Mich.

Letting the Family Sell Itself

Home demonstrations have accounted for many of the sales of a dealer in a small Iowa town. Here is what Seward Heggen, of Thor, Iowa, a town of 300 people says:

"I have long since learned that store demonstrations are not always satisfactory and that sales are more apt to result from a demonstration in the home. In the store, there is often that interruption from other customers which often distracts the prospects' thought and breaks the line of selling. Frequently in the store you must tune-in an undesirable program due to the time of day and the poor location in the business section. I find it helps if the prospect comes to your store first. This gives an opportunity to show the complete line and to determine in your own mind the price, and style the prospect has in mind. When I have decided this, I arrange for a demonstration in the home. This is always in the evening as soon as possible after dinner. The whole family listen-in and I permit each to tune-in a few stations for himself. Out of the last twenty-five demonstrations, I have closed the sale on all but three."

Tying In With Factory Advertising

We prepared a special newspaper advertisement of our own, writing copy suitable to our own store which ties in with factory advertising in our local newspaper. The display advertisement occupied ten inches, cost \$44.10, and sold \$2200 worth of radio receivers. This represented a ratio of 4900 per

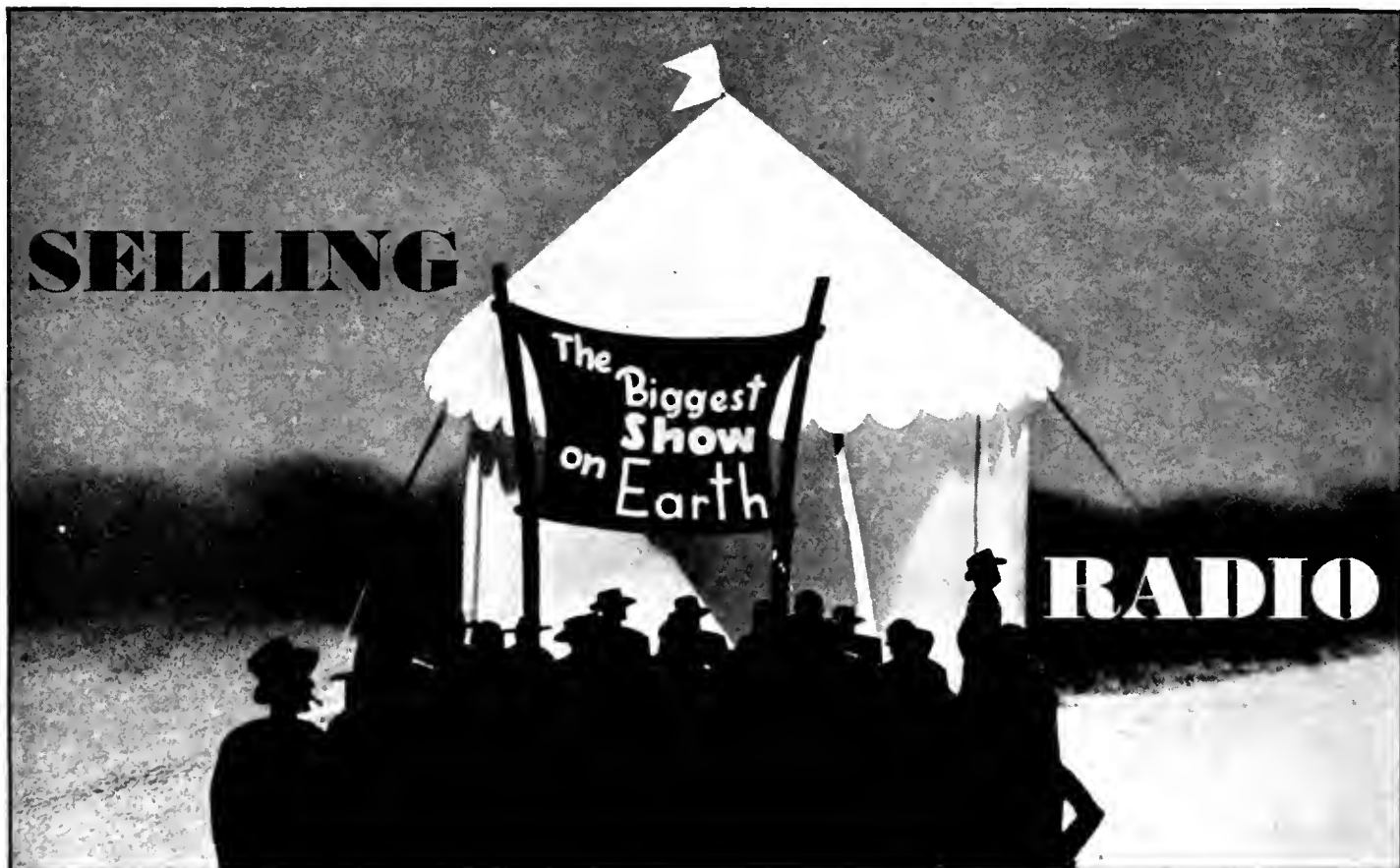

Designed and photographed by Larry June, cutouts by Walter Stiner

By HOWARD W. DICKINSON

Merchandising Consultant

WHY LEAVE all the wonderful power of showmanship in radio to the Graham MacNameses, the program people in the broadcasting companies, and the advertising agencies?

The business of radio, the art of radio, both are full of opportunities for showmanship. In broadcasting there is a perpetual fight between pure showmanship and advertising. So broadcasting is somewhat of a compromise, as of course it must be. We can't keep on giving a show without gate receipts. There is no fence about radio, tickets cannot be collected and it has to be endowed by advertising, sometimes well disguised, sometimes poorly disguised.

Opportunities for Showmanship

There is enormous opportunity for good showmanship in the sale of receiving sets, and in most cases it is entirely lacking.

You want a radio set. You go to a radio shop. Sets are on display. Their workings will be explained. They will be demonstrated, rather poorly in most cases. You, the customer, may be interested in only three questions, "Will it hook on to an electric light plug? How much does it cost? How will it match your furniture?" You get answers to those three questions. You buy and there you are. That has been a *demand* sale. If there are enough of them the dealer does well. If he does well another dealer settles down in the next block. If both do well, a couple more come in. Good Old Demand begins to be over-worked. A demand volume good enough for two is spread too thin over four or six. War begins, shading of prices perhaps, over-allowance on used sets, expensive service free.

Each one of the four, five, or six dealers thinks that if the rest of them would only drop dead or go broke he might have a chance. There is only so much *demand* in a community

anyway. He thinks mildly of making more demand. If he is a general handler of electrical appliances, he may find it more interesting to push vacuum cleaners or washing machines or go after wiring contracts and just take radio work and radio sales as they drop in. So, while his radio business ought to be growing fast, he is permitting it to fade.

Analyzing this situation, we find that our good dealer friend is an electrical merchant instead of a radio showman.

Analyze retail opportunity in radio and you will find that it comes particularly to the man who makes a good radio showman of himself.

The Free-Show Idea

Now as to showmanship and its value: most everybody likes a show, particularly a free show. Announce a league ball game free for one day and thousands of people will spend five or ten dollars apiece to get there. If doors open at 9 A. M.



DEMONSTRATE THE FREE SHOW

hundreds will spend most of the night waiting in line to get in. They will buy food, cigars, rent stools to sit on, and invest several times the price of admission.

Radio has that wonderful free show psychology. The dealer does not work it for one tenth of what it is worth. He makes the mistake of trying to offer things free himself. He doesn't need to if he will only stress the free things which come over the air. He is in the enviable position of providing fairly expensive transportation to a free show. His cue is to advertise the show as well as the transportation.

What is the real show in radio? Of course, it is broadcasting. Are you, Mr. Dealer, a student of broadcasting? Are you an intelligent salesman of broadcasting? Are you making full use of the fact that broadcasting is free? Are you presenting that last fact all the time, tactfully and vigorously? Or have you taken it for granted that broadcasting is a business entirely apart from your own? Do you make the mistake which the broadcasting companies themselves make of forgetting your existence, of neglecting to provide you with the wealth of fact which you could use to join with them in selling radio?

They think their own public contact is sufficient. Let us see if it is. Their daily contact is with the people who have and use receiving sets, your contact is with people who have



KNOW THE ANNOUNCERS

The broadcasting companies owe you more support than they give you.

Yes, the broadcasting companies give the show that makes your business possible. You need them and they need you. There's more money for them in cooperating with you, and your very existence hangs on their strength.

How can you exploit the big show profitably? Now we are getting down to cases, I'll answer this question by asking other questions.

How much time and attention do you give to broadcasting and how much do you listen-in?

Do you study the merits of the various programs which are broadcast and do you know the names of the important ones and their sponsors?

What do you know of the personalities of the various announcers? How they get their jobs and why are some of them famous?

Well, what of it? What good will it do you to do all this and learn all these things?

Right here I wish I had a magic pen that would give a vivid picture in ink of the delight and profit which lie in being a thoroughgoing expert.

Learn About Broadcasting

If your own conversational range in sales contact is purely mechanical or electrical, you will fail to use the theme which is of greatest interest to your customers, because nine out of ten of them are neither mechanically nor electrically minded. Your explanation of the construction of a set will affect them very much as a doctor's does when he says that a patient has a "sympathetic dilation of the coronal membrane." He doesn't know whether to ring up the undertaker or buy an eyewash. "Sympathetic" sounds good, he needs sympathy. But those other words have a terrible sound.

(Concluded on page 58)



VISIT THE STUDIO

not yet bought sets, or who want better sets, or who need mechanical service. Your contact, in other words, is with those who for some reason do not see the big show or find it unsatisfactory. To see the show one must have a radio set. To enjoy the show properly one must have a good set and it must be working properly. That's simple isn't it? You stand ready to supply the good set and to service it, therefore, your contact is with the undeveloped and poorly satisfied part of the radio audience. More than that, you function regularly in adding to the audience and in giving them better seats, by which I mean the chance to hear better and enjoy more.

PROFESSIONALLY



SPEAKING

WHAT we consider to be a most dangerous practice has been recommended to servicemen recently.

Radio receivers, says a contemporary radio publication, are still so fractious and engineering is still in such an embryonic state that it is practically impossible to make significant measurements of sensitivity, selectivity, and fidelity. It is necessary—according to this editorial writer—to make hundreds of measurements on many individual units of a given model before a curve can be obtained which will be representative of that model. Even then, day to day measurements cannot check, etc., etc.

However, using home-made apparatus, this publication has made curves of several well-known receivers which are turned over to installers so that they can fix up the set on the job to best suit the customer. If the curve shows a deficiency in amplification at low frequencies, the installer can, with his handy screw driver, wiggle the condenser plates, or otherwise make up for a dip in a curve which the manufacturer of that set either could not iron out or thought was advisable.

This practice must be condemned before it even gets started. A radio receiver can be measured carefully in the set manufacturer's laboratory; apparatus for such measurements has been available for many months and it is being improved continually. The manufacturer turns out a receiver which is adjusted according to his specifications as shown by his instruments, and for the screw-driver expert to attempt to alter these adjustments is out of the question. We do not believe a single reputable manufacturer would want such local adjustments to be made.

PROBLEMS FOR STANDARDS COMMITTEES

AS WE see it, there are three problems for the Standards Committees of the various trade organizations. The question of "power detection" is one which needs attention. Power detection should be defined, just as dynamic loud speakers and electric sets were defined. At the present moment the term is used in a very loose manner, and, therefore, it has very little meaning. Some manufacturers have power detectors, some linear detectors, some linear power detectors. Definitions are needed for all these terms.

Another matter that needs attention is the business of measuring the output and frequency characteristics of loud speakers. At the present time there seems to be no accepted method by which the performance of a loud speaker may be determined, and some engineers even refuse to look at curves on other people's products because as they say, they do not mean anything.

Present practice consists in facing a loud speaker with a

calibrated microphone and amplifier, putting various electrical frequencies into the loud speaker and measuring what comes out. The differences of opinion on such measurements are regarding the distance of the microphone from the loud speaker, whether or not the loud speaker and microphone should be in a sound-proof room, or whether it should be in an infinitely absorbing space like the great out of doors. Some measurements are made in what looks like an enormous padded cell or like the refrigerating room in a steamboat. Others are made in a room in which reflection from the walls forms a considerable part of what the microphone picks up. And so on. Some standard practice should be evolved.

The present method of measuring a receiver's sensitivity in terms of the field strength required to give 50 milliwatts of power output is open to the objection that this level is too

low. The average power in a loud speaker is probably two or three times this value, and at times the peak power must run as high as 1600 milliwatts for a single 245-type tube, and twice this, at least, for a push-pull 245 power amplifier. What is the sensitivity of the receiver at these output levels?

The Standards Committees should review the method of testing sensitivity with these thoughts in mind. Detectors in 1929 differ from those of a year ago—and they may operate quite differently with a high input than they do at moderate or average output. Perhaps a more complete method would involve measuring the sensitivity at both average and peak outputs.

OUR SERVICE PROBLEM

STORIES OF how servicemen solve baffling problems are like the stories your friends tell of their killings in the stock market—they never tell of their failures. To hear a serviceman talk you would think he plays a game—and he frequently does—and that after considerable detective work, in which he is not only Sherlock Holmes but Dr. Watson too, he always wins. Probably he does, but who loses? Very frequently it is the customer.

We were called in to see a friend's radio set. It hummed something terrible. A serviceman had been called in. He said a transformer and a resistor strip had burned out. It would cost \$25 and take a couple of weeks' time to make the repair.

We took out the power tube. It still hummed. We took out the rectifier and the hum stopped. Clearly the trouble was in the rectifier or loud speaker circuit—not the radio circuit. Without throwing any bouquets at ourself, we found the trouble in a few minutes. The power tube was a 210 with 300 volts (or more) on the plate. The frame of the loud speaker was grounded, and poorly insulated binding posts brought power

(Concluded on page 60)

Please Note—

- Who knows what "power" Detection is?*
- Needed—a standard method for measuring loud speakers.*
- What is the measure of a receiver's sensitivity?*
- Who pays the high cost of poor service?*
- Beware of the screw-driver radio expert.*

YESTERDAY, TO-DAY, and TO-MORROW

Thoughtful Opinions of Retailers on Many Topics Useful to Dealers and Manufacturers. Some Are: New Models, Distance, Selling Claims for Sets, Speedy Handling of Consumer Inquiries, Competitive Demonstrations.



THE MAN on the firing line of radio selling usually has something interesting to say about his daily problems: interesting to his fellow dealers and interesting to the manufacturer. In this article are some suggestions, selected from the report of a survey made *for*—not *by*—one of radio's leading manufacturers. These dealers who speak aim to be constructive, the emphasis is to correct radio ways of thinking and ways of action which seem to deserve it. These dealers naturally do not stop to praise what is good; they hasten to discuss conditions which seem to them less than satisfactory.

These suggestions cover a wide range of topics: competitive demonstrations, factory-dealer tie-up advertising, ill effects of selling sets on distance-getting qualities, when new models are disturbing, proper and speedy handling of consumer inquiries inspired by manufacturer-advertising, and better and more intelligent selling of present models.

These comments are worth more than merely a basis for discussion. They offer the dealer renewed opportunity to examine afresh his own house and a chance to take stock of his own selling methods. These questions concern the dealer as well as the manufacturer. Radio selling is quite as much the immediate problem of the dealer as it is the ultimate concern of the manufacturer.

MORE INFORMATION NEEDED

One dealer interviewed believes that the local store should sell sets by using compelling arguments rather than the usual generalities. He says: "Our observation is that there are too few dealers who know why the set they sell is better. It is a good one in the main and that is all they know.

"What every dealer is mightily in need of is more detailed

information so that he can explain to the average prospect *why* he has a superior product. We have had wonderful success with the Blank set, but it was no fault of the manufacturer that we did. We had a man who knew mechanical construction and when a prospect expressed interest, he showed, point by point, the superiority of that set from the mechanical viewpoint. If our salesman did not know his facts but tried to find out from what the Blank company furnished us, he would have been up against a stone wall.

"As I see it, most dealers talk in generalizations about their sets, and when they are through, they have said nothing but that it is good. To me that spells "bunk." The Blank ads rave on about beautiful cabinets, etc., and the fact of the matter seems to be that this is about all they have. We need a more sincere set of manufacturers—manufacturers who are more anxious to give the dear public a little more for their money. When they do this and when they describe their product in greater detail, then you will see a great sale of their goods right at once. Nothing succeeds, I think, like being able to talk intelligently on the item you are selling and information presented properly to the average customer sells him or her that set. Personally, I would certainly welcome more coöperation between the manufacturer and the dealer."—DEALER A.

MANUFACTURER'S ADVERTISING COPY

"You fellows in advertising have a fine lot of theoretical ideas about copy and plans—but you never make a plan for a dealer. If you did make a good one, it would be planned solely to get prospects and the way would be made easier to get them. So far, all dealer copy is built on the name of the manufacturer who fondly thinks he is the whole show—and you fellows let him do it because it is the easiest way to a big

appropriation. What is needed now is a little Harry Kirtland logic—or Ben Sweatland knowledge—and properly applied.”
—DEALER B.

A FEW NEEDED IMPROVEMENTS

“Below are listed a few things that we think the manufacturers should stop doing:

1. Advertising competitive demonstrations and urging a customer to try out all makes of sets. When he has tried out 8 or 10 of them the profit of 3 sales are eaten up.
2. Stop advertising getting distance. There are places where the best set made will not get a thing. I know a location where no set made will even get the local station one mile away.
3. Stop advertising 10 days free trial. We do not leave a set over night.
4. Stop coming out with new models in the middle of the big season. New models should come in June. They are now coming in January and February and business slackens up right after Christmas.

“We find the manufacturer loses much that should really be produced. The advertising in newspapers does bring inquiries. These, in turn, are turned over to one or two ‘distributors’ on a certain day of the week, or the ‘distributors’ receive them alternately. By the time they reach the dealer in the particular neighborhood, at least ten days to two weeks or more have passed. In the meanwhile the interested prospects have purchased something else. From sad experiences we have discovered that most radio prospects make up their minds very quickly.”
—DEALER C.

BETTER SERVICE NEEDED

“The success of a radio set depends as much on the service rendered by the distributor or jobber as by the manufacturer, if not more so. We cancelled a good franchise at one time because the jobber gave little or no service.”
—DEALER D.

ADVERTISE THE DEALER

“It is our opinion that every manufacturer’s ad in newspapers should carry a list of authorized dealers. It is educational. Customers will go to reliable dealers instead of ‘gyps.’”
DEALER E.

ADVERTISING SHOULD CONSIDER LOCAL CONDITIONS

“Manufacturers advertise here in Great Falls where we are 500 miles from the nearest station in the same manner that they advertise in the metropolitan district where listeners are in the shadow of the towers of the transmitter. It seems to us that different conditions call for different tactics in newspaper advertising.”
—DEALER F.

And finally, here is an interesting dealer letter which points out that manufacturers should try to sell the advantages of modern radio entertainment in their ads.

“The radio situation as we see it is decidedly unhealthy. Public interest in radio entertainment is very keen, but the public is being terribly confused by the ridiculous conflict of advertising claims by manufacturers who seem to think that they are dealing with a wholly imbecile public. Years ago in the automobile trade, they had just about the same sort of orgy of extravagant advertising—everybody claiming the biggest and the best, but no one giving any facts to support his claims.

“Right now, the newspapers in this section are full of the sort of ads that might be expected from a flock of blue-sky promoters, each claiming that some particular make of radio is the only one worth considering, but none of them providing any evidence or reasons to back their claims.

“Meanwhile, no manufacturer of radio is doing anything constructive to help me send twenty-five or thirty-thousand old sets—sets that are no longer fit to be kept in service—to the scrap heap, by advertising in a way that will help sell the idea of up-to-date radio entertainment and its superiority over what could be had from the old five-tube neutrodynes and four-tube bloopers.

“No manufacturer is telling newspaper and magazine readers anything about the real delights of owning any of these modern sets. They are all good and any one of them is a mile ahead of the goods we were selling a couple of years ago, but a lot of our prospective

customers think they are enjoying the best there is in radio, when as a matter of fact all they are getting is a lot of squeaks. They do not know what they are missing, but they read these ads in the papers and conclude that the radio manufacturers are a pack of liars and the result is a lot of extra resistance to overcome when we try to sell them a new radio receiver.

“If some radio outfit would come out with a line of advertising that doesn’t depend entirely on bragging about the latest model (n.p., accenting the pleasures to be had from a modern receiver and throwing in a few facts and specifications) the public could not fail to be impressed. It would be so different from the usual type of copy.

“Personally, we think we are rapidly approaching the time when it will be in order to have two or three sets in every house. We have begun to cover our field. But we should try to do a better job before the public gets altogether disgusted with us. We must sell our sets by pointing out the real advantage of listening to up-to-date radio equipment.”



LEOPOLD STOKOWSKI (Conductor, Philadelphia Orchestra): “The big thing in radio is this—that it permits us to bring our music to the people, in no matter what station in life, in every part of the world.”



D. E. REPLOGLE (Television Committee, R.M.A.): “That television will require distinct and new receivers separate from the radio broadcast receiving set is now assured from the progress being made in the laboratory.”



PAUL G. ANDRES (Temple Corporation): “The use of the earth’s magnetic field will open up communication channels that are not affected by water and land barriers which, in the case of ether waves, now are at a premium.”



J. B. KNIGHT, JR. (DeForest Radio Co.): “The South has become definitely radio-minded, in spite of its slow start.”



J. E. SMITH (National Radio Institute): “The unexpected and steadily increasing demand for radio-trained men by marine and air radio, broadcasting, production, merchandising, and service organizations has caused the demand to exceed the supply.”

WHAT

“Automatic phonographs make an attractive side line.”

“Radio dealers, who are anxious to increase their volume and profits, will do well to investigate opportunities afforded by the introduction of new automatic musical instruments which are rapidly coming into general use by restaurants, confectioneries, clubs, auditoriums, parks, and better class homes. The unit of sale is six to eight times as great as on the average radio set, the sales expense is very little, if any, greater, and the profit margins are very attractive.

“Another attractive feature of marketing automatic phonographs is that a great majority of installations are made in the downtown business sections, convenient for sales calls.

“Among radio dealers who have made outstanding successes in the sale of automatic phonographs are the Wahn Radio Company of Boston, Mass., Alford & Fryar of Canton, Ohio, Pearson Piano Company of Indianapolis, Indiana, and Listenwaller and Gough of Los Angeles, Calif. These dealers handle the Capehart Orchestrope, manufactured by The Capehart Corporation, Fort Wayne, Indiana. This instrument plays a continuous program of fifty-six selections from twenty-eight selected phonographs records, using an electric pick-up, a three-

THEY



SAY . .

stage amplifier, and an electrodynamic loud speaker. They manufacture a complete line of models, both coin and non-coin operated.”

E. D. LASHBROOK

Sales Manager, The Capehart Corporation

Time Payments

A dealer in a rural community writes on time payments as follows:

“I believe that time payments and trade-in are two things much abused and overdone. We dealers are very much in need of education on both of these matters. We have dealers in our town who are trading in old battery sets at from \$25 to \$65, and reselling them at about one fourth of this. A deplorable situation you will admit.

“To some extent we believe manufacturers are to blame for being lax in granting franchises to any Tom, Dick, or Harry. Right here in my town one of the largest of the set manufacturers has two dealers, one located in a shoe store who sells sets as a side line for most anything he can get. The other is a young fellow selling the sets from his home—he has no established place of business.

“We would appreciate any moves you might make for the betterment of the industry. Radio with us is not a side line but a business.”

HOW RADIO SALES COMPARE BY STATES

From the figures given in the article by T. A. Phillips, “An Estimate of Set Sales,” in Sept., 1929, **RADIO BROADCAST**, it is possible to plot a curve showing set sales by states for the radio year July, 1928, to July, 1929. This curve is given herewith and makes it possible to determine readily the percentage of the total radio business done by any given number of states. It shows quite clearly, in somewhat different form,

the fact (not new) that a very small number of the states do a major part of the radio business. For example, six states—New York, Pennsylvania, Calif., Ohio, Ill., and Mass.—do fifty per cent. of all the business; sixteen states do eighty per cent. of the business. From the curve it is, therefore, a simple matter to determine how many and what states must be covered to take care of any given percentage the total sales.

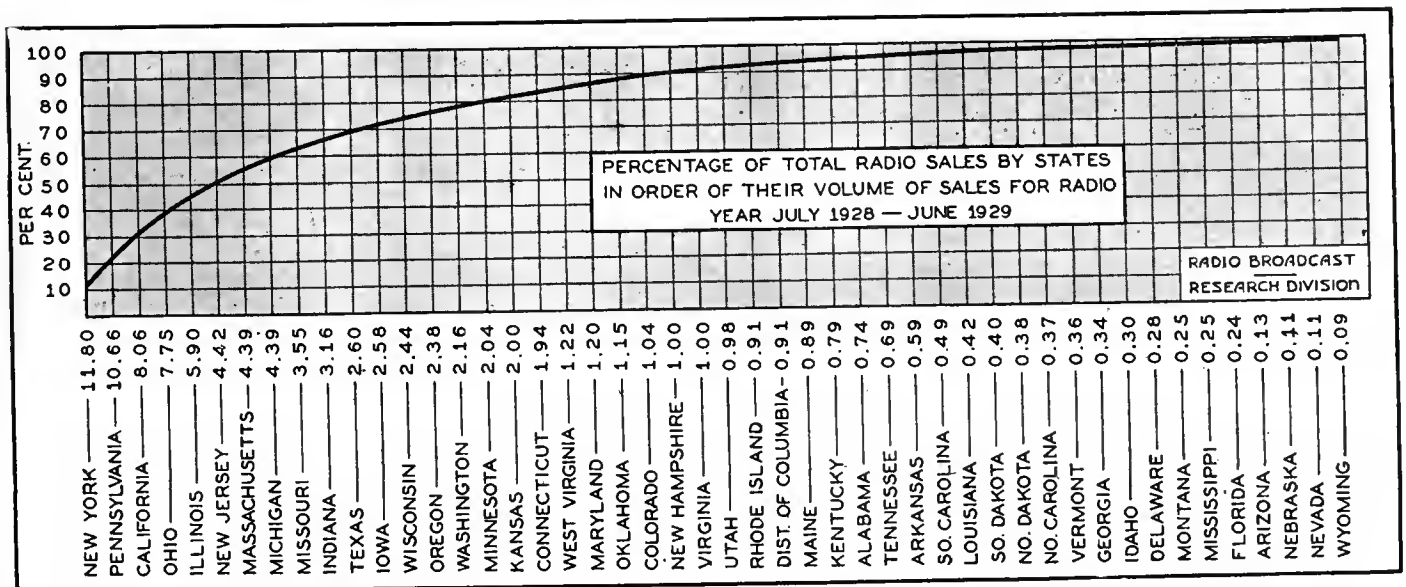

In this graph the figure accompanying each state represents the percentage of total sales by that state.

The MARCH

Keep Radio From the Side Lines
Patent Problems Are Still With Us

If Automobile Dealers Sell Radio

ISSUED APPARENTLY as an inspired rumor, the statement has appeared in the press that the Radio Corporation of America is negotiating with the General Motors Corporation to distribute radio receivers through the immense retail organization of the latter company. Although the correctness of this rumor has been flatly denied, radio dealers nevertheless view the threatened competition of automotive distribution channels with alarm.

From the beginning the most prejudiced observers consid-

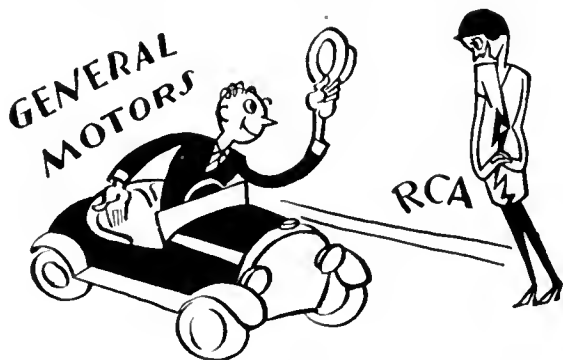

ered it highly improbable that the RCA would make such a drastic and disloyal shift in its distribution arrangements. On the other hand, if the General Motors Corporation were to decide to stabilize the business of its dealers by adding radio as a side line, it would have no difficulty in finding a radio manufacturer ready to hand over his distribution or even his entire business. That manufacturer, however, would be guilty of a serious blow to radio retailing, if he were the means of adding another major retail distribution system to the excessive number already handling radio products. His example would probably be followed by other radio manufacturers who have not been able to build up satisfactory distribution systems.

Some short-sighted radio manufacturers seem obsessed with an insatiable desire to force bona fide radio dealers out of business and to relegate the distribution of their products to the position of a mere side line of other industries. The exclusive radio store or one having a few minor side lines has always been the most satisfactory outlet for radio products, because only a specialist, an expert in the sales and service problems of radio, assures the greatest satisfaction to the buyer.

A survey, recently made by the National Electrical Manufacturers' Association in cooperation with the Department of Commerce, reveals an extraordinary diversity of outlets handling radio products, far in excess, both in number and diversity, of what is warranted by gross sales. The addition of a substantial number of outlets, such as would be affected by making every automobile dealer a radio salesman, would be a final calamity and discouragement to the dealer who concentrates on radios and phonographs. It would be necessary to add only the drug store and the grocery chain to the ranks of radio retailers to place radio distribution on a par with sales of cigarettes and safety pins.

Increasing the number of retail outlets reduces the gross sales per store. Continued progressively, the process is bound to decrease the importance of radio as a selling item and ultimately to reduce it to a minor side line. The revolting increase in distasteful advertising accompanying sponsored programs is bound to cause added sales resistance. The addition of automotive outlets may increase the number of retail distribution points from the present excessive number of nearly 40,000 to as much as 85,000. These factors combined would make concentration on radio sales and service unprofitable, a major calamity to the radio manufacturer. His merchandise would be crowded into an insignificant corner of window space, it would receive minor display in the store and negligible consideration in the management's sales plans. Radio would become, more than ever, a seasonal product, a forgotten item during all but the peak seasons.

The automobile industry, however, is not to be condemned for seeking to improve the position of its retail outlets. Radio would be highly acceptable to the automobile dealer because it would help to correct the dull fall and early winter season experienced in automobile sales. But every sale made during radio's all too short peak season would be at the expense of merchants who have for years concentrated on radio and stood by it through thick and thin. However, if a manufacturer were to distribute radio receivers through automobile agencies he would find his business highly seasonal. In the spring, when a special effort is necessary to maintain production schedules, he would find his dealers too busy selling cars to give any thought or attention to radio.

Whoever conceived this brilliant scheme of consolidating radio and automotive distribution certainly did not have the interests of radio dealers at heart. To the automotive indus-

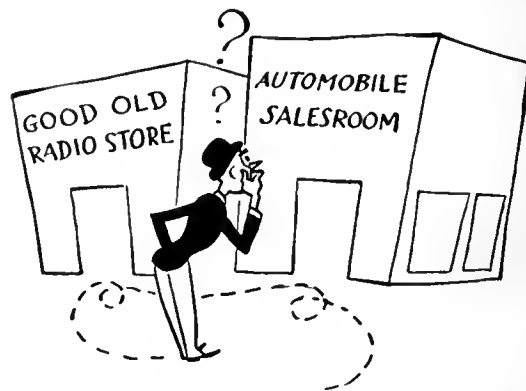

try, radio represents merely a means to an end, and the fate of the radio dealer is none of its concern. Indeed, electric refrigerators made by subsidiaries of automobile concerns are a major source of complaint among household appliances as creators of electrical interference. Refrigerators made by manufacturers identified with the electrical and radio industries, on the other hand, are suitably shielded to prevent interference with radio reception.

So long as the radio products distributed by automobile dealers are limited to brands specially made for them, automotive outlets are not likely to cause a major disturbance to radio retailers. The public recognizes side-line selling and will prefer to patronize radio specialists handling a variety of

OF RADIO

69 Stores in Radio's Largest Chain
The New Grand Island Radio Station

standard radio receivers. But, if legitimate radio manufacturers cooperate in extending distribution through automotive outlets, they will hasten the day when there are no more radio dealers and when radio receives only the attention given to seasonal side lines.

More Patent Difficulties on the Way

THE DECISION of Judge Hugh M. Morris, holding that the Radio Corporation of America has infringed U. S. patents 1,455,141 and 1,635,117, popularly known as the Lowell and Dunmore patents, threatens to present further serious difficulties to radio manufacturers. Substantially these patents describe methods of eliminating the hum induced in radio receivers by power-supply devices. Actually, there are a considerable number of patents not covered by the Radio Corporation license to set manufacturers which are as yet unadjudicated. Many of these concern such fundamental principles as shielding, by-passing, and gang condenser construction. In absence of adjudications, such patents receive scant attention from the industry. These patents are held largely by individual inventors and, if the license scales proposed are any criterion, their values are placed sufficiently high to discourage outright purchase in advance of litigation. It will be some years before we are at the end of infringement difficulties of this kind which, if favorably adjudicated, require that the entire industry make its terms with individual inventors.

The New Monitoring Station

THE MONITORING station, to be erected by the Department of Commerce at Grand Island, Nebraska, will serve the field of radio communications throughout the world much as the British Observatory at Greenwich has influenced astronomy and navigation. We expect that the Grand Island station will become the criterion by which frequencies are judged and thereby present the solution of many of the problems of frequency stability. One of the great difficulties existing today is that we have no generally available yardstick by means of which frequency standards may be readily compared. Much heterodyning would be eliminated if stations adhered to their



assigned frequencies. The amount of deviation tolerated is positively amazing and goes a long way toward rendering the work of the Federal Radio Commission less effective. A tour of the dials with any sensitive receiver at almost any location

reveals many more places with a heterodyne than points of good reception. Were the public not accustomed to securing its radio entertainment from two or three nearby local stations the present conditions would be intolerable. Improved con-

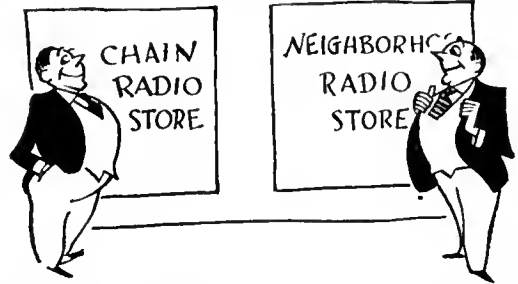

ditions, brought about by accurate frequency adherence, would make radio more acceptable to the rural listener.

Radio's Largest Chain Store

THE ATLAS STORES CORPORATION, of Philadelphia, has purchased City Radio Stores and Davega, Inc., through an exchange of stock. The consolidated earnings of the combined companies last year were \$1,400,000. The Atlas Corporation will have 69 radio stores in operation when the merger is completed and will thus be the largest radio chain in existence. Although chain store methods are making tremendous inroads into many forms of retail merchandising, they threaten least goods of occasional turnover and infrequent renewal. Drug and grocery products can be effectively sold through chain store merchandising methods because a wide variety of items is handled and the purchaser is protected by standardized and labelled goods. The average grocery or drug purchase involves a small amount with the result that individual reputation and personality in selling, a factor submerged by chain distribution methods, is not of vital importance. Radio chain selling has been successful only in concentrated markets in major cities where bargain hunters and experimenters still flourish.

Radio Commission Reorganized

THE FEDERAL RADIO COMMISSION has been reorganized in accordance with recommendations of government efficiency experts. With the exception of the chairman, each member of the commission has been appointed to head a division of its activities, Commissioner Sykes being head of the legal division, Saltzman engineering, Lafount field investigation, and Starbuck liaison. Sub-committees have been established on hearings, courts and legislation, on budget and control, on planning and policies, and on procedure and publicity. Hearings will be taken by special examiners who will report the evidence to the full membership of the Commission.

This form of organization should improve greatly the consistency of the policies adopted by the Commission.

—E. H. F.

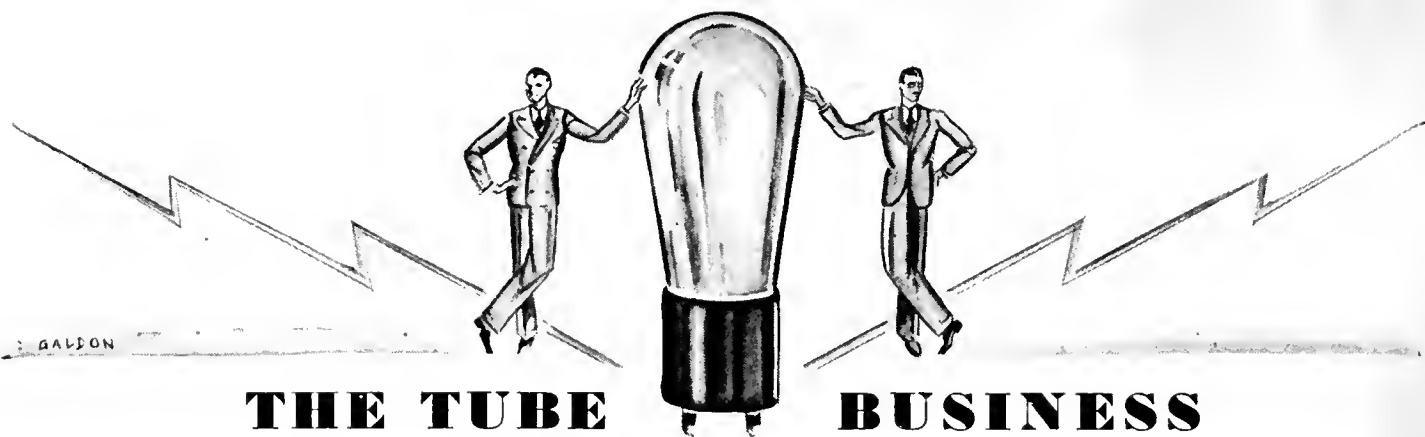

THE TUBE BUSINESS

NEW DEFOREST TUBES

A NEW D.C. screen-grid tube has been announced by De Forest. This tube uses an oxide-coated filament which is much heavier than the usual thoriated emitter. It operates at one third the temperature, has plenty of emission to last over 1000 hours, and is free from microphonic noises.

DeForest has also placed on the market a new 210-type tube with an oxide-coated filament and a very large plate with appropriate supports and insulation to guard against breakdown when used as a high-frequency oscillator. It is capable of dissipating 25 watts on the plate.

WORLD'S LARGEST TUBE LINE

SONATRON MANUFACTURES 44 distinct types of tubes, thereby backing up its well-known slogan of having the world's largest radio tube line.

MUSIC FOR EMPLOYEES

TWENTY TWO loud speakers have been installed in the assembly and manufacturing departments of CeCo's new million-dollar plant. One hour each morning and each afternoon the employees are permitted to listen to music transmitted over this network of loud speakers. It has been determined that this innovation decreases fatigue, increases production, and decreases shrinkage.

FINANCIAL NOTES

THE BALANCE SHEET of the Hy-Vac Radio Tube Corporation, as of June 30th, after giving effect to the sale of 38,000 shares of stock showed net tangible assets of \$283,640.03. Current assets amounted to \$246,910.31 including cash in the amount of \$201,309.69 as compared with current liabilities of \$12,384.02 or a current ratio of over 19 to 1.

An issue of 400,000 shares of the newly formed National Union Radio Corporation at about \$40 per share starts the company off with an initial capitalization of \$16,000,000.

In the seven months ending July 31, CeCo sales were off 3.7 per cent. from a year ago.

The Noma Electric Company with the Pilot Radio and Tube Company has purchased the plant of Everett Mills in Lawrence, Mass. The entire production will be concentrated there within a year. This plant has floor space to the extent of 1,500,000 square feet.

A MANUFACTURING FORMULA

A COMMON DENOMINATOR which any tube manufacturer can use to determine the number of tubes per day he can turn out is the amount of floor space in square feet per tube per day required. It has been determined that about two square feet is necessary and that a figure of from two to three square feet per tube per day

means a well-ventilated factory with ample space for operators so that they can work efficiently. Thus a factory with 20,000 square feet of floor space can turn out a maximum of about 10,000 tubes a day, and somewhere between this number and

c-324 tubes and they contain not only the usual material about dimensions, proper voltages, etc. but also a complete set of characteristic curves, methods of using the tubes properly, and a bibliography of articles dealing with the particular tube in question. Such material is invaluable for engineers in the tube or receiver business.

Tube Sales and the Serviceman

BY HARRY C. HOLMES

General Sales Manager, DeForest Radio Company



Harry C. Holmes

THE SERVICEMAN is one of the most valuable outlets we have in the vacuum tube industry. He is not only a serviceman, but a good-will emissary and an excellent salesman as well, since he generally speaks from experience.

The serviceman cares but little about the decorative scheme of the tube carton or the superlative claims of the maker. He is interested in just one thing: a good vacuum tube. A serviceman with faulty tubes is as badly off as a mariner without a compass, since he has nothing to go by. The serviceman is fully familiar with this point, and as a result he generally becomes "sold" on some particular line or lines of tubes. Once convinced himself, he becomes the best type of salesman.

The capable serviceman inspires confidence in the radio set owner. He is the doctor who cures the ailing set, and in nine chances out of ten the replacement tubes he prescribes are the tubes the owner will continue to buy in the future.

Serviceman salesmanship, I believe, is the greatest antidote we have to-day for "bargain" tubes and merchandising ballyhoo. You can't fool the serviceman in quality. He knows. And by his recommendations the radio public is getting to know and to appreciate quality vacuum tubes.

6000 tubes a day indicates a combination of economical use of floor space and good working conditions for the operators.

QUICK HEATING TUBES

MARVIN CLAIMS the world's record in the construction of a quick-heating tube. It is the MY-227, is guaranteed to heat in five seconds flat, and compares favorably with all other tubes of this type with respect to life, freedom from hum, etc.

GOOD TUBE BULLETINS

CHIEF ENGINEER D. F. SCHMITT, of E. T. Cunningham, Inc., and his staff engineers must be congratulated on the excellence of their engineering bulletins. We have the bulletins on the cx-345 and the

TRIAD'S TUBE BOXES

WE HAVE already commented on the triangular shaped tube boxes of Triad. Tests conducted over a period of some weeks have disclosed the fact that there was but 2 per cent. damage to boxes of this type compared to 18 per cent. with the usual four-sided carton.

OPERATING COST OF A.C. SETS

ACCORDING TO George Lewis of Arcturus all this talk that it is costing more to operate the modern a.c. sets than the old-style battery sets is unwarranted. If anyone, according to Mr. Lewis, will take the trouble to compare the number of revolutions that the wheel in his electric light meter makes when his radio is turned with the number when a 75-watt lamp is lighted, he will find out the number of watts the set takes.

It amounts to less, in dollars and cents, than is required to charge a storage battery and buy new B batteries regularly—such as we all had to do a year or so ago.

BULLETIN ON THE S. G. TUBE

THE ATWATER KENT radio dealer bulletin No. 3, July 17, 1929, has an interesting and instructive illustration of the manner in which a screen-grid tube prevents unwanted oscillation and squealing. If the receiver of a telephone is put near the mouthpiece of the transmitter, the telephone line will oscillate or howl. If the mouth piece is screened with a sheet of metal or other material the howl ceases. Thus it is with the screen-grid tube, says the Atwater Kent bulletin. The screen-grid between the grid (input or mouth-piece of tube) and the plate (the output or receiver of the tube) prevents oscillation. At the same time the amplification due the tube can be increased some five to ten times over that obtainable with three-element tubes.

The explanation is a simple graphic picture of the screen-grid tube and might be used by tube manufacturers who want to help their dealers sell the new tubes, by informing them properly about how they work. Atwater Kent suggests that dealers put the bulletin, which is appropriately illustrated, in their show window.

NEW TUBE MANUFACTURER

THE DILCO RADIO TUBE CORPORATION, Harrison, N. J., is a new addition to the list of those in the tube business. The advertising agency is Charles Dallas Reach of Newark.

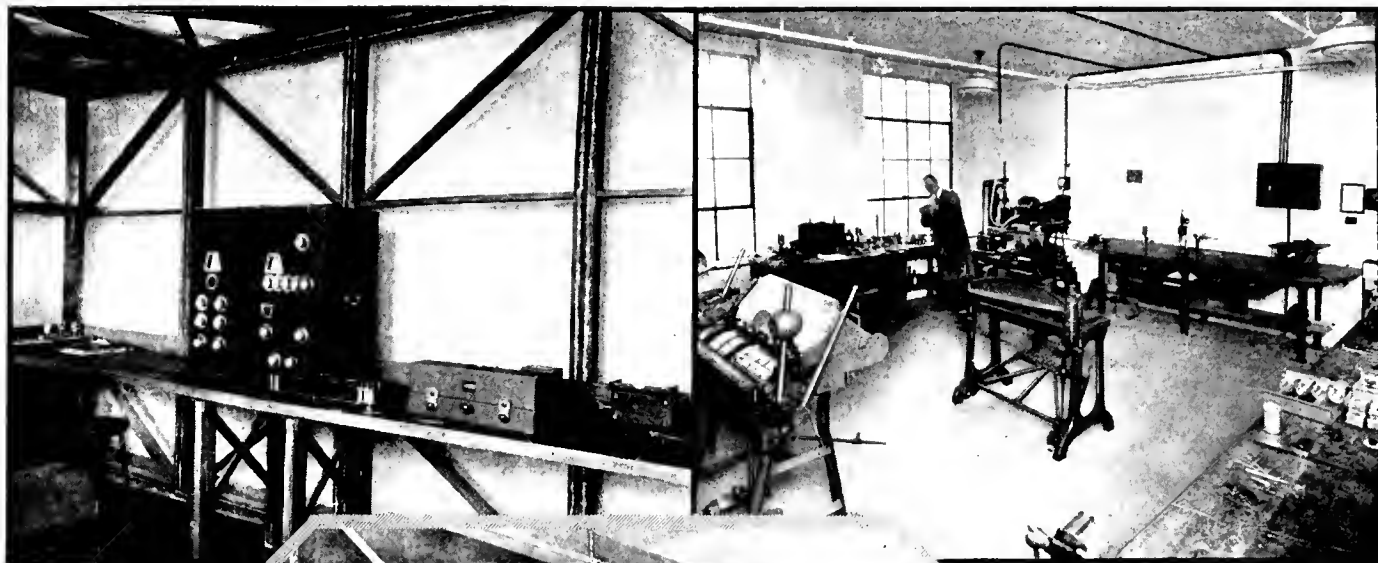

Radio-frequency signals of amplitudes down to microrolls can be obtained from the signal generator shown above.

The Hazeltine Laboratories, located on the top floor of a multi-storied Manhattan building, have ample light in their well-equipped mechanical workshop.

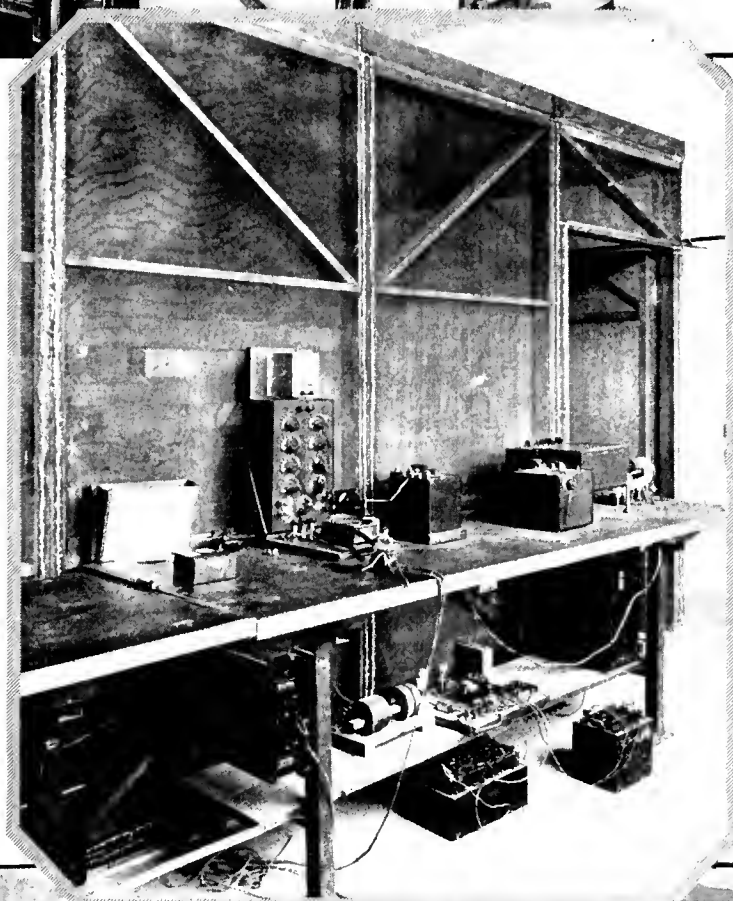

Selectivity, sensitivity, and fidelity characteristics of receivers are measured with this shielded "gain set."

The "cage" room pictured on the left is shielded from electrical disturbances and is used for making many measurements. It is equipped with instruments (General Radio) for measuring inductance, capacity, and resistance.

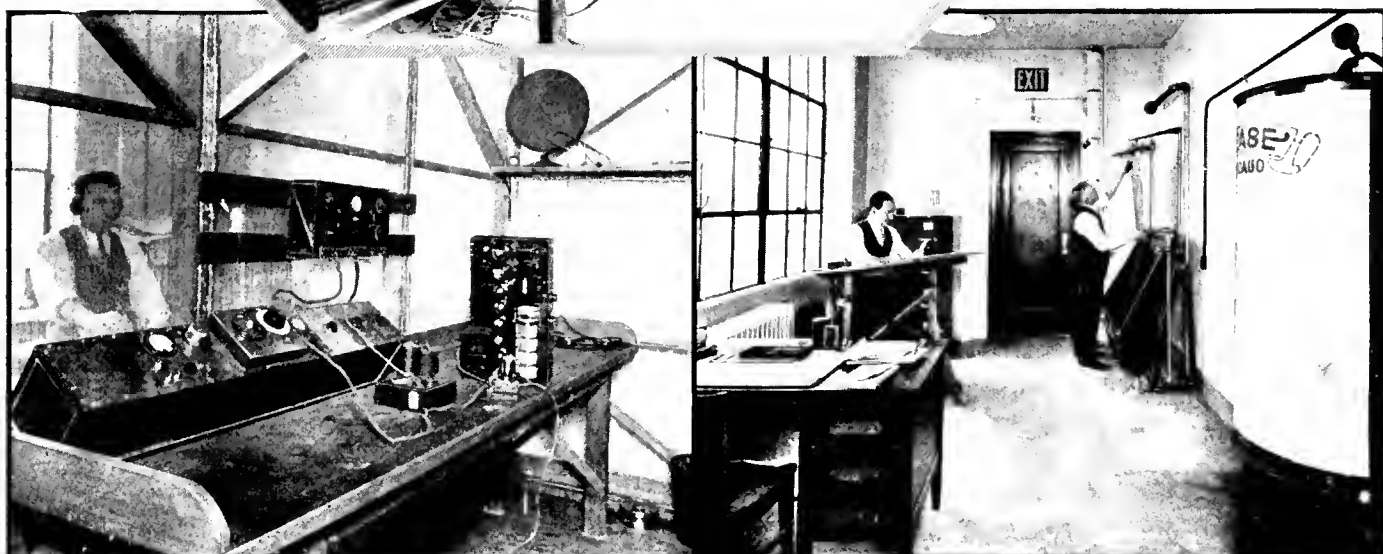

The drafting room is a very important part of any well-equipped laboratory.

THESE UP-TO-DATE LABORATORIES SERVE HAZELTINE LICENSEES

On this page are presented various views in the new laboratories of the Hazeltine Service Corporation, maintained for the benefit of the licensees of the Hazeltine Corporation. Radio set manufacturers in the United States who are licensed under the patents of this organization are: All-American Mohawk, Anrad, Fada, Bremer-Tully, Crosley, Earl, Freed, Gilfillan, Grebe, Howard, King, Philco, Stromberg-Carlson, and U.S. Radio and Television.



RADIO

General Motors Buys Day-Fan Electric Company

Entry of General Motors into the radio manufacturing field was announced late in September by Alfred P. Sloan, Jr., president of the corporation. General Motors has purchased the entire business of the Day-Fan Electrical Company, of Dayton, Ohio, and receivers made by this company will now be known as a product of General Motors. There will be no change in the policy of the Day-Fan Company, according to Sloan's statement.

Previous to this announcement, David Sarnoff, executive vice-president of the Radio Corporation, put to rest the rumors that General Motors would take over the distribution of Radio-Victor products by stating that negotiations had been in progress between General Motors and R. C. A. only with regard to licensing the motor organization to manufacture receivers. Purchase of Day-Fan carries with it an R. C. A. license.

R C A Institutes Formed

RCA Institutes, Inc., has been formed as a subsidiary of the Radio Corporation of America, with Rudolph L. Duncan as president. Headquarters and main school will be at 326 Broadway, New York, N. Y. The new company has acquired the Philadelphia School of Wireless, and the Eastern Radio Institute of Boston. New schools will be started in Newark and Baltimore, and others are planned for principal cities. The resident schools will provide regular classes for instruction in commercial radio operating, servicing and radio mechanics. Each school will provide correspondence courses as well.

Chas. Freshman Returns

Through acquisition of the Colonial Radio Sales Co., Inc., of New York City, Charles Freshman returns to radio. Chas. Freshman Radio Stores, Inc., has been formed with Chas. Freshman as president, B. Abrams (president, Emerson Radio & Phonograph Co.), and Sidney A. Joffe (formerly merchandise manager of Colonial Radio Sales). Eleven stores are in the chain and headquarters are at 3 East 43rd Street, New York.

More Space for Walthal

Walthal's, New York radio chain, has added 60,000 square feet of space to their warehouse at 233 Spring Street, New York. Here the main office and shipping department are located in an eleven-story building, to be renamed the Walthal Building. Walthal is a subsidiary of Wextark Radio Stores.

Addition to Crosley Plant

The new eight-story addition to the Crosley plant at Cincinnati is nearing completion and at present three floors are already finished and in operation.

Temple to Build New \$500,000 Plant in Chicago

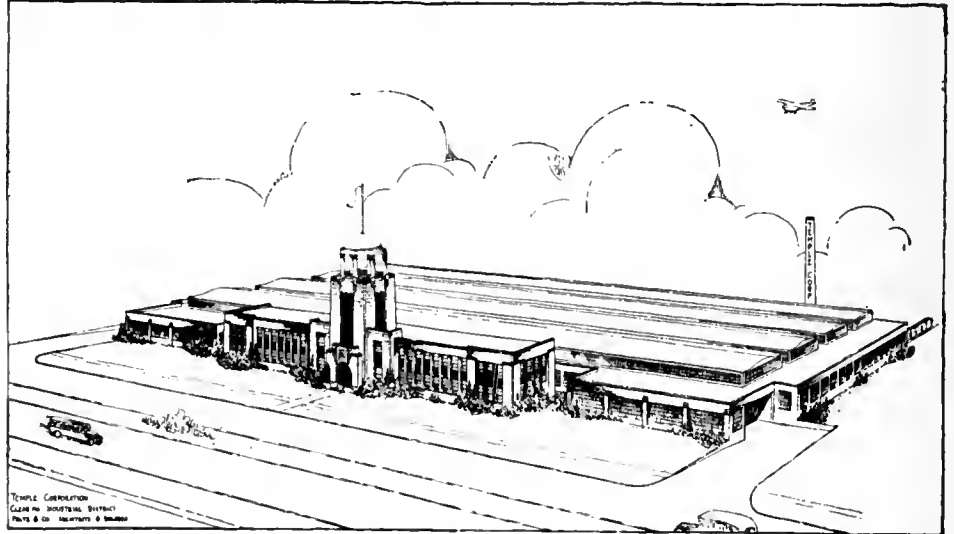

The above is an architect's drawing of the Temple Corporation's new \$500,000 manufacturing plant in the clearing industrial district of Chicago. Construction will start immediately.

Gulbransen Dealer Finance

Gulbransen of Chicago has concluded arrangements with the Commercial Investment Trust (C.I.T.) for a finance plan to be made available to their dealers. The plan in general provided a 90 per cent. advance to the dealer, low rates, and a return of the reserve on liquidation. The dealer is allowed to make his own collection, continuing his contact with the purchaser.

New Set Price Catalogue

For the first time the trade has available a complete reference handbook of all receiving sets and loud speakers. The handbook, issued by General Contract Purchasing Corp., 420 Lexington Avenue, New York, N. Y., is priced at \$2 per copy which includes a correction service. The book includes names and addresses of set and loud speaker manufacturers and their branch offices, names of company officials and their branch managers, all recent consolidations and mergers, trade association memberships, patents and patent licenses held, broadcasting of manufacturers, types of sets and loud speakers manufactured, cabinet styles, types of all tubes used in each set or loud speaker, and list prices of all the models.

Loftin Sells Patents to R. C. A.

Sale of a group of patents by the Loftin-White Laboratory to the Radio Corporation of America has been announced by E. H. Loftin. The sale includes the non-reactive plate circuit method of preventing oscillation and the constant coupling system published in technical papers some months ago. The sale does not include the direct-coupled audio amplifier which the Loftin-White organization has developed.

Gilby Wire Expands

The Gilby Wire Company, 150 Riverside Ave., Newark, N. J., is constructing additional factory space. About 20,000 square feet will be added to their present plant and a 100 per cent. increase of production potentialities will result. The engineering department has been enlarged and new products will be added to the present Gilby line. Among the new products are carbonized nickel, rolled selvaged mesh, and seamless nickel tubing.

New Radio Magazine

After two years of preparation, the Standard Publishing Company, of Cincinnati, announces the publication of *What's on the Air*, a magazine with a guaranteed circulation of 150,000 among people who listen to radio programs. The magazine is designed to enable advertisers to send their printed sales message to their listeners simultaneously with their broadcast programs.

New R. M. S. A. Headquarters

Executive offices of the Radio Service Managers Association have been established at 1400 Broadway (Room 401), New York City, under the supervision of Grover C. Kirchhoff, executive secretary. Servicemen and service managers may take examinations at this address between the hours 9 A. M. and 1 P. M. except Saturdays.

Service Problems Considered

The Radio Executive Committee, Pittsburgh Chamber of Commerce, has been discussing the question of qualified radio servicemen, and plans are being formulated to increase the supply and quality of these men. T. C. Foley is secretary of the division.

Jenkins Television Production Announced

With the recent development of a novel combination scanning drum and selector shutter disc by its engineering staff, resulting in a simpler, more economical, and far more practical scanning system, the Jenkins Television Corporation, of Jersey City, N. J., now announces the mass production of television apparatus.

"With our latest development," states James W. Garside, president, "we have evolved a remarkably simple, inexpensive, and highly practical televisor, which can be readily manufactured at a reasonable cost. The new Jenkins televisor will permit of receiving either plain black-and-pink radiomovies or full half-tone pictures, with good detail and illumination within the limitations of our 48-line system.

The R. C. A. Theremin

The forthcoming exploitation of the Theremin, a new musical device, has been announced by the Radio Corporation of America, and a new department of the Radiola Division of R. C. A. has been created under the direction of G. Dunbar Shewell, as musical devices sales manager. This device was first demonstrated publicly at the Metropolitan Opera house by its inventor, Professor Theremin of Russia, and later at the Lewisohn Stadium. It consists briefly of two oscillating circuits, one of which is fixed in frequency and the other is variable and under the control of the operator both in frequency and volume. The difference between these two frequencies is an audible note which is amplified and fed into a loud speaker. It is understood that the "RCA Theremin" will be sold as a musical instrument for about \$175. It was also demonstrated during The Radio World's Fair at Madison Square Garden, September, 1929.

Huge Bosch Radio Furnishes Band Music for Parade

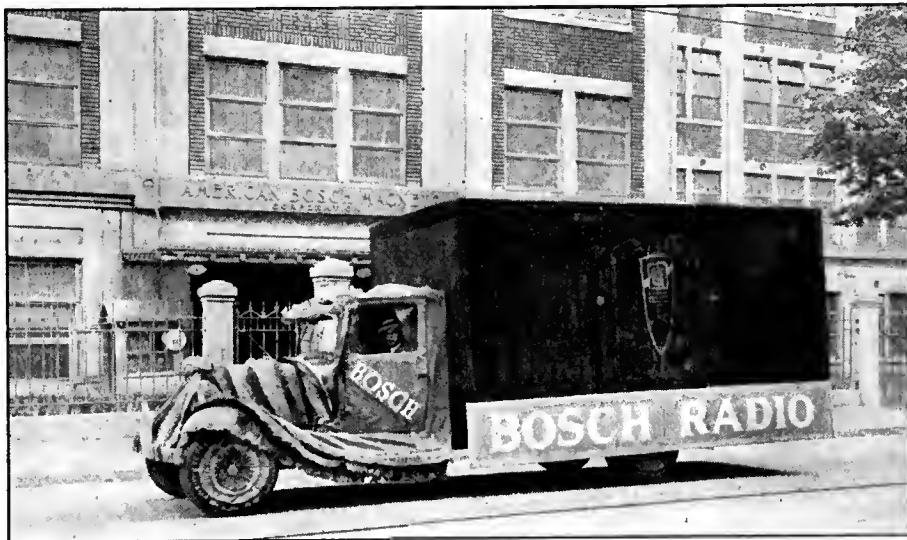

The American Bosch Magneto Corporation mounted a huge replica of the new Bosch Radio on a decorated motor truck as a float in a recent parade in Springfield, Mass. An electric phonograph was also employed to provide band music for the marchers in the parade.

Personal Notes

William C. Poole has been appointed chief electrical engineer of Transcontinental Coil, Inc. He will be in complete charge of both the laboratory and inspection departments.

Rufus H. Caldwell, who previously has been associated with the American Telephone and Telegraph Company, the Sleeper Radio Corporation, and the DeForest Phonofilm Company, has been appointed chief engineer of the Colin B. Kennedy Corporation. Mr. Caldwell designed the new Kennedy screen-grid receiver.

Ralph H. Langley, director of engineering, Crosley Radio Corporation, has been elected chairman of the Cincinnati Section of the Institute of Radio Engineers for the coming year.

W. L. Marshall, formerly advertising manager of the Victor Talking Machine Corporation, has been promoted general advertising manager. Mr. Marshall will be in complete charge of all advertising, sales promotion, and publicity activities of the company.

Walter A. Coogan, has taken over the management of export sales for the Arcturus Radio Tube Company, of Newark, N. J. Mr. Coogan will specialize in foreign sales advertising.

Frank W. Dowsett is advertising and publicity representative of the Kolster Radio subsidiary, Canadian Brandes, Ltd. He has charge of the house organ, Kolster News, and prepares advertising and sales helps.

The CeCo Manufacturing Co. have announced five new appointments: Edward T. Maharin, vice president, has been appointed a director of the company; Maximilian F. Mautner has been appointed assistant treasurer; G. V. Christianson has joined the company as sales representative in northern New York; Henry C. Grout has been made sales representative in Rhode Island, and Emmett Tydings has been appointed sales representative in western Pennsylvania and West Virginia.

Frederick J. Kahn has been appointed chief field engineer of the Brandes Laboratories, Inc., a subsidiary of Kolster. Previously Mr. Kahn held the position of service manager for Kolster.

D. E. Repogle, formerly an engineering executive with Raytheon, and chairman of the R.M.A. committee on television, has joined the Jenkins

Jones Loses Suit

A decision handed down by District Judge Marcens B. Campbell in the cases of Lester W. Jones vs. Freed-Eisemann Radio Corporation and Lester L. Jones vs. Walthal Electric Corporation declares the Jones patents No. 1,658,804 and No. 1,658,805 invalid. These cases were defended by the Hazeltine Corporation due to the fact that Jones endeavored to prove that a normal neutrodyne receiver infringed the Jones patents. Judge Campbell held that even if the patents were good there was no infringement by either Freed-Eisemann or Stromberg-Carlson.

DeForest vs. R. C. A.

Claim for triple damages against the Radio Corporation of America was filed by the DeForest Radio Company on September 11 in the United States District Court at Wilmington, Delaware, as a result of the suit fought and won by the DeForest company with regard to the violation of the Clayton Act by the Radio Corporation, according to a statement issued by J. W. Garside, who claims that his company suffered serious financial losses as a result of the much-discussed Clause Nine.

Television Corporation, of Jersey City, as assistant to the president.

Leonard Welling, president of K. W. Radio, New York distributor for Sonora, has been elected a member of the Sonora board of directors.

Harry H. Steine is still vice president and sales manager for the Triad Manufacturing Company contrary to publicity reports. Samuel S. Sanford, who was erroneously announced to be sales manager, has been appointed sales engineer.

Howard W. Angus, formerly director of public relations for the Radio Corporation of America and also in charge of the licensing activities of R.C.A., has resigned to accept an appointment with Batten, Barton, Durstine, and Osborne Advertising Agency, of New York City, as head of their radio department.

Stephen G. Pratt, of the Kolster sales department has been appointed assistant sales manager of the eastern district. Mr. Pratt was formerly affiliated with the Victor Talking Machine Co.

George Lyons has been appointed to the merchandising and market survey division of the Atwater Kent sales promotion department. Mr. Lyons has held important posts with several companies including Victor and Brunswick.

Leslie F. Muter, vice president of the Steintz Radio Company, has been elected to the board of the Radio Manufacturers' Association. He has also been appointed chairman of the Association's credit committee.

Gene M. Latham has been appointed district sales manager of the New York-New Jersey territory for the Temple Corporation.

E. F. Bergere, who for the last five seasons has been connected with F. A. D. Andrea, Inc., in the Central West, has been appointed district sales manager of the Milwaukee, Minneapolis, St. Paul, and Rockford territory.

The Friedman-Snyder Company, of 15 Park Place, New York City, are Eastern Sales Representatives for Transcontinental Coil, Inc.

Chas. Eisler, president of the Eisler Electric Corporation, Newark, sailed recently for Europe to establish permanent agencies in 15 foreign countries for the sale of tube- and lamp-making machinery.

New Broadcast Programs

GULBRANSEN: Beginning Saturday Evening, October 5th, this company inaugurated a series of symphony concerts by the Manhattan Symphony Orchestra conducted by Henry Hadley. The program is broadcast over the Columbia Broadcasting system for one half hour every Saturday evening, from 9:30 to 10:00 o'clock Eastern Standard Time.

PHILCO: Three concerts by the Philadelphia Orchestra under the direction of Leopold Stokowski and sponsored by the Philadelphia Storage Battery Company will be broadcast over the air on October 6th, November 3rd, and December 8th.

CeCo: Each Monday evening the CeCo Manufacturing Company sponsors a program by the CeCo Couriers over twenty-two stations of the Columbia Broadcasting System.

Production Figures

The Arcturus Radio Tube Company broke all previous production records in August by packing a total of 776,931 tubes. This represents a considerable increase over the average monthly output of \$303,697 for the first three months of the year and is more than 1200 per cent. greater than the monthly production figure of 60,000 tubes for 1928. Production in the various Arcturus plants ran as follows: January, 326,601; February, 248,819; March, 335,672; April, 334,330; May, 431,800; June, 440,863; July, 512,781; August, 776,931. Arcturus now occupies 195,000 square feet of floor space, compared with 35,700 feet in January. More than 50 per cent. of the machinery for the new plant is in operation.

Gulbransen's production schedule was advanced to 1000 per day in October according to an announcement by John S. Gorman, vice president of the company.

The Earl Radio Corporation made and delivered 13,975 sets in June, 23,564 in July, and August production was expected to be 32,000 sets. In September production will be stepped up to 40,000 receivers.

N. Y. Association Rating Servicemen

The Radio Service Managers' Association, 1400 Broadway, New York, has begun a system of examining, rating, and placing servicemen. The first few weeks of operation have given the following results: 110 men examined, 69 passed, 41 failed, 21 placed. The men who passed the examination were rated as follows: 9 class A, 31 class B; 29 class C.

G. C. Kirchoff is executive secretary and will be interested to hear from other associations and those interested in the work the R.S.M.A. has in progress. Rating cards are issued to the successful examinees. "Of those who failed to pass our examination," says Mr. Kirchoff, "the number who claim to have been employed as servicemen is surprising."

News of the F.R.T.A.

"One of the chief purposes of the Federated Radio Trade Association" according to Michael Ert, president, "is to assist local associations to organize in their own localities. Through the medium of booklets outlining the organization of a local radio trade association and on running a local radio show, we have been successful in organizing associations in 45 communities.

NEW MEMBERS FOR F.R.T.A.

Four new local associations which have joined the Federated Radio Trade Association are: Wichita Radio Trade Ass'n., Curt Hubbell, secretary, Wichita, Kansas; Radio Dealers Ass'n. of Northern Kentucky, C. M. Johnson, secretary, Covington, Ky.; Des Moines Radio Merchants' Ass'n., J. T. Schilling, secretary, Des Moines, Ia., and the Mahoning Valley Radio Dealers' Ass'n., W. H. Conklin, secretary, Youngstown, O. With these additions, there are now 31 local trade associations with membership in the F.R.T.A. Initiation fees for local associations are \$1 and dues \$25 annually with the privileges of sending two voting delegates to annual meetings.

The Radio Wholesalers' Association announced the addition of the following new members: Charles C. Hicks and W. H. Nolan, North Central Distributors Inc., Minneapolis; J. M. Camp, Brown-Camp Hardware Co., Des Moines Ia.; Earl R. Goodin, Goodin Radio Corp., Wichita, Kans.; E. L. Kern, Kern-O'Neill Co., Minneapolis, Minn.; C. A. Winne, Stewart-Warner Sales Co., Minneapolis, Minn.; George A. Michel, The Belmont Corp., Minneapolis, Minn.; L. B. McCreary, Western Radio Co., Kansas City, Mo. The total membership of the association is now more than 200.

OBSOLETE SETS BURNED

Local trade associations in more than ten cities, in cooperation with the Federated Radio Trade Ass'n, staged radio bonfires to demonstrate the uselessness of old battery sets. Cities in which the events were held include San Francisco, St. Louis, Minneapolis, Chicago, Milwaukee, Des Moines, Kansas City, Omaha, and Covington. Dealers cooperate in collecting the sets, frequently from their own stocks, hold a parade to the spot for the fire, and the Mayor of the city is invited to touch the first match. Newspapers have been generous in their cooperation, some special radio fire sections have been published, and movie news reels have taken pictures of the event. The local associations are plugging the idea that "old sets are obsolete" and linking that thought with the slogan "The Modern Home Needs a Modern Radio."



Charles Eisler, Eisler Elec. Corp.

Change of Address

Jenkins & Adair, Inc., Chicago manufacturers of special audio apparatus for broadcasting and sound pictures, have moved to 3333 Belmont Avenue where their office and factory is housed.

E. T. Cunningham has rehoused its Pacific Coast headquarters in a new building at 325 Ninth Street, San Francisco.

Recently Issued Patents

- No. 1,721,960, System of Modulation. James E. Parker, Washington, D. C. Filed March 1, 1923.
- No. 1,721,965, Amplifying Circuits. Francis X. Rettenmeyer, Montclair, N. J., assignor to Western Electric Company, Inc., New York, N. Y. Filed May 11, 1926.
- No. 1,721,987, Selective Constant Resistance Network. Otto J. Zobel, New York, N. Y., assignor to American Telephone and Telegraph Company. Filed April 13, 1928.
- No. 1,725,433, Band-Receiving Systems. Frederick K. Vreeland, Montclair, N. J., assignor to Vreeland Corporation, New York, N. Y. Filed August 1, 1927.
- No. 1,725,710, System and Method of Television. John Hays Hammond, Jr., Gloucester, Mass. Filed August 15, 1923.

Patent Suit

No. 1,448,279, Pridham & Jensen, Electrodynamic receiver, filed June 8, 1929, D. C., N. J., Doc. E 3856, The Magnavox Co. v. O'Neil Mfg. Corp.

Reproduces Current Radio Poster for Dealers' Meeting



F. M. Dinan, advertising manager (right), and R. Haynes, service manager, New Haven Electric Company, created quite a stir in Philadelphia recently by reproducing in complete detail one of the current Atwater Kent posters on the occasion of the visit of the New Haven Electric Company and 250 of their dealers to the Atwater Kent plant.

Financial Notes

Griggsby-Grunow's stockholders are smiling these days. Earnings are running in excess of \$1,000,000 a month net, or at the rate of \$30 a share, according to W. C. Grunow, vice president. Gross sales for the ensuing twelve months will reach 100 million dollars compared to 49 million last year. The capital stock has been increased from 500,000 to 2,000,000 shares; the shares have been split up four-for-one to stockholders of record on August 16.

Polymet has increased its capitalization from 60,000 to 300,000 shares of no-par value stock and the stock which is outstanding at present has been split up three-for-one. The new stock has been placed on a \$1.00 annual basis payable quarterly. Stock dividends at the annual rate of 4 per cent. have been declared. They begin on January 1, 1930 to all stockholders of record on Dec. 20, 1929. At the first annual meeting the following Board of Directors was re-elected: Carl L. Schmidt, Edmund J. Sampter, Otto Heineman, Foster G. Smith, Judge Hadley Howd, Otto Paschkes, and Nathaniel E. Greene.

Dubilier reports a net profit for the year ending June 30 of \$169,999. This is equal to 56 cents a share on the 304,150 no-par-value shares outstanding. This is to be compared to a net loss of \$131,356 in the preceding year.



B.F. Duhreber
Supreme Inst. Corp.

Radio Products Corporation, formed by the Shultz Machine Company, Inc., will acquire the assets and business of Vacuum Tube Products. The output of this company is some 2,000,000 radio tube parts as well as tube manufacturing equipment sold to prominent tube manufacturers. To finance this purchase 50,000 shares of common stock have been offered to the public through two New York houses at \$36.50 a share. Ultimately 100,000 shares will be outstanding of a total capitalization of 200,000 shares.

Sparks-Withington's success for the past year is shown in the report of operations for the year ending June 30. A net income of \$2,510,322, which, after preferred dividends requirements have been deducted, is equal to \$14.56 a share on 168,690 shares, has been reported. This is compared to a net income of \$1,212,605 or \$8.03 a share on 149,280 shares for the previous year.

The Cardon-Phonoeraft Corporation has been organized to take over the properties of Cardon Corporation and Phonoeraft Corporation, manufacturer of vacuum tubes and automatic phonograph-radio combination. Sale of 100,438 shares of stock at \$24 has been consummated by W. E. Hutton & Co.

General Instrument Corporation stock has been offered through two Chicago brokers in units consisting of one share of Class A and one share of Class B. The price was \$22.50 per unit.

The Atlas Stores Corporation, of Philadelphia, have completed arrangements for the acquisition of City Radio Stores and Davega. This will bring the number of stores in the Atlas chain up to 69. An issue of 50,000 shares of stock convertible into common will probably be made, bringing the total number of shares up to 300,000.

Tube Prices Increase

New prices on several types of tubes have been announced by a number of tube manufacturers. These are increased prices and involve the following types:

200A	\$4.00
240	3.00
11	3.00
12	3.00
uv 199	2.75
ux 199	2.50
120	3.00

Last year the combined earnings were \$1,400,000.

Wextark Radio Stores, Inc., shows sales for the seven months of the present year to June 30 of \$7,049,856 and net earnings of \$730,647. This is a holding company in part and owns or controls through direct or stock ownership the following companies: Wextark Radio Stores, Inc., Columbia Radio Corp., Waltham Electric Corp., Duovac Radio Tube Corp., Chicago Salvage Stock Stores Inc., Allied Radio Corporation, as well as a loud speaker manufacturing corporation and jobbing companies.

Acoustic Products' stockholders have approved a plan of recapitalization which involves exchanging preferred stock for common on a basis of eight shares of common for one of preferred with an additional two shares of common in consideration of waiver of dividends arrearage on each share of preferred, making in effect a 10 for 1 exchange. Common stock has been increased to 1,500,000 shares. Stockholders will probably be offered the right to subscribe to 300,000 of the new shares.

The Temple Corporation, to provide additional funds for expansion, has offered holders of preference stock rights for additional stock at \$30 per share. At the present time 35,000 shares are outstanding.

The DeForest Radio Company has offered to purchase all outstanding shares of Jenkins Television through an exchange of shares on the basis of 1 for 1 1/2 of Jenkins. If the offer is accepted DeForest must issue 570,000 new shares, bringing the total to 3,570,000.

Distributors Appointed

KELLOGG: A factory branch with F. W. Lorenz in charge has been established in the Cleveland territory for direct distribution to dealers. Office and warehouse space have been leased at 1531 West 25th Street, Cleveland.

PHILCO: The May Distributing Corporation represent Philco in the New York area. D. W. May is president.

STERLING: Superior Distributors, Inc., are exclusive distributors for Sterling Concertone Receivers in the New York Metropolitan area. The Sterling line is on display at 154 West 52 Street adjacent to the company's offices at 150 West 52 Street.

SONORA: Announcement is made by this company of the appointment of the H. P. Schade Company, 1329 North 15 Street, Philadelphia, as distributors of Sonora Radios and the Sonora Radio-Melodion.

KENNEDY: This company recently announced the appointment of the following distributors: Reibold, Inc., of Bismark, N. D.; Clinton Paper Company, of Clinton, Iowa; The Northland Electric Supply Company, of Minneapolis, Minn.; Hafer Supply Company, of Joplin, Mo.; Carroll Electric Company, Inc., of Washington, D. C.

KOLSTER: The Commercial Electric Company was recently appointed distributor for Kolster and Brandes receivers. The Commercial Electric Company recently moved to its location at 14 North Erie Street, Toledo, Ohio.

TRIAD: Recent distributors appointed by the Triad Manufacturing Company include the Beaudette and Graham Company, of Boston; Stuyvesant Electric Company, of New York City, and Lehr Automotive Supply Company, of New York City.

EDISON: Roy S. Dunn, western sales manager of Thomas A. Edison, Inc., recently announced the establishment of Renier Brothers, Dubuque, Iowa, as a distributor of Edison radios, phonographs and records. The new Edison distributor will serve dealers located in northwestern Iowa, southwestern Wisconsin and northwestern Illinois.

New Equipment Ships 580 Radio Receivers per Hour

By means of a carousel conveyor, radio receiving sets can be carried to waiting freight cars at a rate of 580 per hour at the new addition to the plant of the Crosley Radio Corporation, Cincinnati, Ohio. Three floors of the eight-floor addition have been finished and are in operation.



IN THE RADIO MARKETPLACE

News, Useful Data, and Information on the Offerings of the Manufacturer

New Crosley Receiver

CROSLY RADIO CORPORATION: Two screen-grid tubes are used in this new receiver, the Monotrad, which lists at \$62.00. It is a complete a.c. -operated receiver with two 245-type tubes in the output. The feature of the set is the triple-range control switch by means of which the user has three different positions for local, nearby, and distant reception.

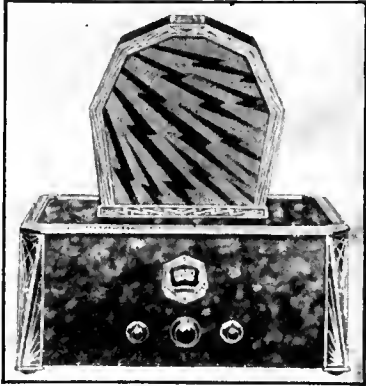

Super Akra-Ohm Resistors

SHALLCROSS MANUFACTURING COMPANY: These resistors are designed for use in radio receivers and as laboratory standards. Normally the resistors are accurate within one per cent, but greater accuracy may be had when desired. They are practically non-inductive, have a temperature co-efficient of 0.0001, and will dissipate 1 watt. They are available in values from 5000 ohms to 5 megohms.

New Kennedy Receiver

COLIN B. KENNEDY CORPORATION: The receiver employs three tuned r.f. stages with screen-grid tubes followed by a 227-type detector and two 245-type tubes in push pull. The chassis is available in two cabinets, a Lowboy and a Highboy Console. The gain of the receiver is uniformly high over the entire broadcast band.

New Columbia Receivers

COLUMBIA PHONOGRAPH COMPANY: The Selector Tuner is a feature of some of the new Columbia receivers. By means of it the dial may be adjusted for any one of eight favorite stations by pushing the proper button located on the dial. The Model c-11 is of the cabinet type which houses an eight-tube a.c.-operated radio receiver utilizing five 227-, two 245-, and one 280-type tubes. The loud speaker which uses



a Burtex diaphragm has a cone 11 1/2 inches in diameter. Price: \$155.

The Model 940 uses the same chassis. This model is a combination phonograph and radio. The record bins contain room for sixty records. Price: \$297.50. The Model 920 is a Columbia Viva-Tonal electric phonograph, the power amplifier using one 227-, two 245-, and one 280-type tubes. An induction motor operates the turntable which is equipped with an automatic stop. Price: \$197.50. The Model 180 is a small portable electric turntable and phonograph pick-up unit designed for use in conjunction with a radio receiver for electric reproduction of phonograph records. This portable instrument can be located at any reasonable distance from the radio receiver, the two being connected by means of a flexible cord. Price: \$55.00.

Small Fixed Condensers

CORNELL ELECTRIC MANUFACTURING COMPANY, INC.: This company manufactures small fixed condensers in capacities from 0.0001 to 0.006 mfd. They are readily mounted, will stand a flash test of 1500 volts d.c., and use a dielectric consisting of three 0.0005" sheets of pure linen paper.

The Silver Model 75

Silver-Marshall, Inc.: Effective September 1, a new model of Silver Radio, known as the Model 75 Concert Grand, was added to the line which now consists of two models, the Sheraton Lowboy and Highboy cabinets. The



Model 75 Concert Grand houses a Model 30 Silver Radio eight-tube, screen-grid chassis exactly similar to those furnished in the Model 60 Lowboy and Model 95 Highboy. A ten-inch dynamic loud speaker is incorporated in the Model 75 cabinet.

Jenkins Television

JENKINS TELEVISION CORPORATION: This company has announced the completion of their Jersey City transmitter, w2xcr, which will be used to broadcast television signals on 140 meters. It is rated at 5 kw. The first broadcasting will transmit motion picture film.

New Phonograph Pick-Up Unit

BERG A. T. AND S. COMPANY, INC.: This company makes a small portable electric turntable and pick-up unit. List price: \$50.00.

New Thordarson Amplifiers

THORDARSON ELECTRIC MANUFACTURING COMPANY: The Type T-3715 amplifier lists at \$89.50, has a voltage amplification of 275, and a maximum output of 4.6 watts. It uses one 227- and one 250-type tube with a 281-type rectifier. The Type T-3714, listing at \$84.00, has a volt-

age amplification of 335, a maximum output of 3.5 watts, and uses one 227-, two 245- and one 280-type tubes.

The "Golden Voiced" Table

KIEL FURNITURE COMPANY: A special table has been designed by this company to house the Atwater Kent screen-grid receiver and



dynamic loud speaker. The top of the table opens and inside of it can be housed the radio receiver and loud speaker. The table acts as a baffleboard and the loud speaker plays through an opening in the bottom.

Issue New Manual

AEROVOX WIRELESS CORP.: A new condenser and resistor manual giving specifications for the various types of condensers and resistors made by this company has just been issued.

Antenna Apparatus

SWAN-HAVERSTICK, INC.: Antenna kits of various types, insulators, wall plates, light-socket antennas, lightning arrestors, etc., are illustrated in the new catalog of this company.

New Gulbransen Receivers

GULBRANSEN COMPANY: The screen-grid Model 292 is equipped with a ten-inch dynamic loud speaker and radio-frequency transformers designed to give uniform sensitivity over the entire broadcast band. Normally a light-socket antenna gives satisfactory reception. The set has a local-distance switch and a phonograph-radio switch. Price: \$149.50. The Model 291 uses a similar circuit in a different cabinet. Price: \$139.50.



New Jewell Apparatus

JEWELL ELECTRICAL INSTRUMENT COMPANY: The latest catalog of this company illustrates a number of new miniature instruments in bakelite cases. The line includes instruments for measurement of d.c., low-frequency, and high-frequency currents.

Kellogg 25-cycle Sets

KELLOGG SWITCHBOARD AND SUPPLY COMPANY: Three new models designed especially for use in territories supplied with 25-cycle current have been added to the Kellogg line. They are known as the models 526, 527 and 528 and are similar in appearance and features to the corresponding 60-cycle models, 532, 524, and 525.

New Phileo Receiver

PHILADELPHIA STORAGE BATTERY COMPANY: The new model 95 chassis employs an unusual circuit and a number of new features. Ahead of the first tube is a double-tuned circuit to eliminate cross talk. A two-element detector is used and this is followed by a 227-type audio amplifier. The two-element detector is a 227-type tube with the grid and plate socket terminals connected together. Such a tube has a linear characteristic over practically its entire operating range. The set is also arranged to equalize automatically the volume of all stations. The tubes used in the set are: three 224 screen-grid tubes, one 227 detector, one 227 as an amplifier after the detector, one 227 as an ordinary audio amplifier, two 245's in push pull, and one 230 rectifier. The set will be available as a table model and in three different console cabinets.

New Bremer-Tully Sets

BREMER-TULLY MANUFACTURING COMPANY: The new Bremer-Tully receivers utilize four tuned circuits with 227-type tubes as r.f. amplifiers. In the output are two 245 tubes in push-pull. A phonograph jack is provided for use with an electric pick-up unit. The dynamic loud speaker has a ten-inch cone and its power supply has been designed so as to eliminate any audible hum. The standard Model 31 receiver lists at \$164.00. The DeLuxe Model 32 lists at \$195.00.

New Hammarlund Units

HAMMARLUND MANUFACTURING COMPANY, INC.: Complete units for audio or radio-frequency amplifiers and several special components for use in screen-grid receivers are announced by this company. Among the new items

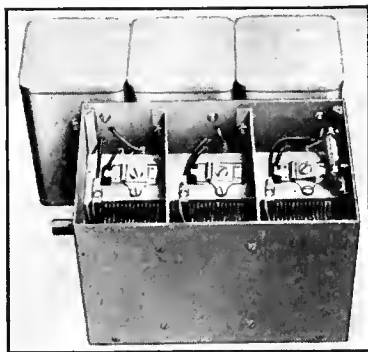

are a three-stage radio-frequency band-pass filter, a complete screen-grid r.f. amplifier, audio-frequency transformers, power-supply apparatus, etc.

Marti Receivers

Marti Radio Corporation: The Marti receivers utilize screen-grid tubes as r.f. amplifiers. The output of the r.f. amplifier feeds into a 227-type power detector and from this tube through an audio amplifier to two 245-type tubes in push-pull. A dynamic loud speaker is used and the cabinet is of such dimension that the baffle length is 47 inches in its shortest dimension. The set lists at \$295.00.

Stromberg-Carlson Model 816

STROMBERG-CARLSON TELEPHONE MANUFACTURING COMPANY: In this receiver are combined the following features: automatic volume control, linear power detection, a "silent key" to cut out noise when tuning from one station



Sonora's New Line

SONORA PHONOGRAPH COMPANY, INC.: The new Sonora sets designed for screen-grid operation each have three screen-grid tubes, a power detector, and one stage of audio with two 245-type tubes in push pull. The chassis are all completely shielded. The dynamic loud speaker contains a filter to eliminate a.c. hum. The radio receivers are priced as follows: Lowboy \$149.50; Highboy \$179.50; DeLuxe \$235.00. The combination radio-phonographs range in price from \$190 to \$695. A feature of the receivers is the Synchro-tone Modulator that insures equally good reproduction at all volume levels.

New Bosch Sets

AMERICAN BOSCH MAGNETO COMPANY: The DeLuxe Highboy Model combines the new Bosch screen-grid receiver with a dynamic loud speaker. The cabinet has sliding doors. Price: \$240. The Standard Model is priced at \$168.50.

New Zenith Models

ZENITH RADIO CORPORATION: Features of the new Zenith receivers are screen-grid circuits, automatic tuning, double push-pull audio amplification, remote automatic control, etc. The Model 52 lists at \$175.00, the Model 53 at \$275.00, and the Model 54 at \$395.00.

Sparton Announces D. C. Set

SPARKS-WITHINGTON COMPANY: To meet the demand for d.c. light-socket-operated receivers two Sparton sets, the Models 931 and 301, have been designed. These models are available at the same prices as the corresponding a.c. models.

New Atwater Kent Receiver

ATWATER KENT MANUFACTURING COMPANY: The Model 66 receiver is a screen-grid set using a total of nine tubes; three 224-, two 227-, and two 250-type tubes in push pull and two 281-type rectifiers. Price: \$135.00.

Electric Phonograph Motor

PACENT ELECTRIC COMPANY: This motor, Model 140, designed for operation on a 50-60 cycle, 110-volt a.c. supply, is of the induction type and is designed especially for use in a phonograph-radio combination.

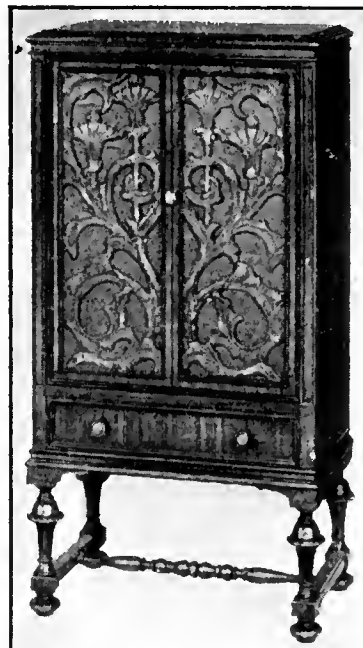
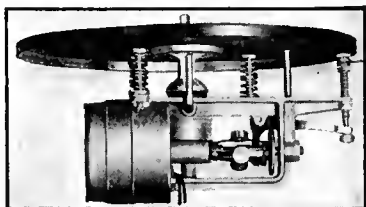

to another, phonograph-radio switch, and a large diameter dynamic loud speaker. This company is also making an electrodynamic loud speaker which is housed in a floor type cabinet. The loud speaker is designed for use with any standard radio receiver. The loud speaker is stated to be from two to four times more efficient than previous reproducers of this type.

Grebe's Screen-Grid Radio

A. H. GREBE AND COMPANY, INC.: An equalized band-pass filter using six tuned circuits, linear power detection, single-stage audio amplifier, and a push-pull output circuit are features of the new receivers announced by this company. The set is known as the Model sk-4 and is available in four different designs. The prices range from \$219.50 for the most inexpensive model to \$450 for a combination radio-phonograph.

The Brunswick Model 14

THE BRUNSWICK-BALKE-COLLENDER COMPANY: The Model 14 Brunswick radio is a nine-tube receiver housed in a lowboy console. This set is completely a.c. operated and lists at \$148.00. The Model 21 uses the same chassis housed in a highboy console, the list price being \$174.00. The radio chassis is combined with an electric Panatropie in the Model 31 listing at \$272.00.

New Radio Accessories

INSULINE CORPORATION OF AMERICA: This company is now manufacturing a number of new items which include various types of interference eliminators, light-socket antennas, resistance type voltage regulators to control the line voltage, and a new "Screen Gridifier," a device for use in converting old type receivers to be used with screen-grid tubes. This device is made in two models, one listing at \$7.50 and the other at \$9.50.

Electrad's New Resistors

ELECTRAD, INC.: This new resistor is recommended particularly for use as a plate resistance, voltmeter multiplier, and in general laboratory work. The resistance wire is nichrome, contact bands and soldering lugs being of Monel metal. It is made in values from 10,000 to 250,000 ohms and the prices range from \$1.50 to \$5.00.

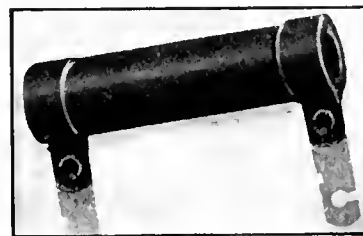

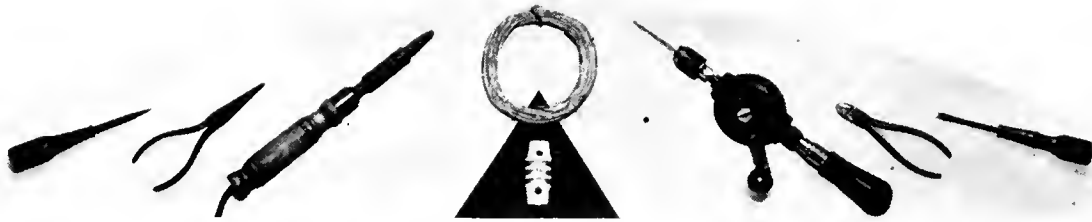

THE SERVICEMAN'S CORNER

Testing Screen-Grid Tubes

BORIS S. NAIMARK, of the Riverside Auto and Supply Company, New York City, dealer in Colonial and Steinite, sends the following interesting contribution in recognition of the test requirements of screen-grid tubes and the almost universal distribution of test sets designed before these tubes became popular.

"The advent of screen-grid tubes has rendered virtually obsolete thousands of perfectly good tube testers. Almost every radio work shop and certainly every radio store has one or more of these testers, which, while perfectly satisfactory in all other respects, are not suitable for testing screen-grid tubes. It is the purpose of this article to describe just how such tube testers may be modernized so that they may be employed to test the four-element tubes. Such a program of modernization involves only a trilling expenditure, under no circumstance exceeding fifty cents for the two units described.

"If the reader has a battery tube-tester and wishes to test the 222-type screen-tube, he can make the necessary adaptor from one UX socket, one UX tube base, two small clips, and about two feet of hook-up wire. If an a.c. tube tester is available, all one needs to do in order to test the 224-type tubes is to assemble an adaptor consisting of one UY tube socket, one UY tube base, two small clips, and hook-up wire. The circuits are shown in Figs. 1 and 2, respectively, and the construction should not present any difficulties whatever.

"All of the above mentioned materials, the reader, no doubt, will find in his 'junk-box.' The construction, of course, is very simple, all data being indicated in the self-explanatory diagrams. The operation of the adaptors is also practically obvious.

"The correct procedure is to place the tube base in the tube-tester socket, place the tube to be tested in the extra socket, connecting the clip marked 'to top of screen-grid tube' to the control grid, and the clip marked 'to B plus' to some suitable positive potential. Then the tube is tested in the usual manner. What constitutes a suitable positive potential for the screen grid? A little experimenting seems to indicate that one third of the applied plate voltage is just about right. This voltage need not be supplied by an independent source of potential and may be easily diverted or tapped off the voltage normally applied to the plate of the tubes ordinarily under test.

"The average tube-tester contains at least two meters, a voltmeter and a milli-

ammeter. The first makes it possible to secure the correct filament voltage. This, of course, should be adjusted to 3.3 volts for the d.c. screen-grid tube, and 2.5 for the a.c. screen-grid tube. The milliammeter indicates the plate current flow in the tube. It is through a comparison of

with its corresponding plate current flow as indicated on the milliammeter. When the button is depressed a different bias condition prevails and, accordingly, the value of the plate current, as indicated on the plate milliammeter, is either greater or smaller than the original reading. It is the difference between the two readings that denotes the utility of a tube in the set. It is impossible for the writer to indicate just what plate current readings will determine a good, fair, or poor screen-grid tube because it is impossible to foretell under just what conditions the test will be conducted. A slight difference in any of the potentials involved in the test affects the readings obtainable. All we can suggest, then, is that the reader test several new tubes and take the readings thus available as indicative of a good tube. Any tube giving readings that fall short of the amounts obtained from a representative group of new tubes is either poor or fair, depending upon the amount of deviation from the standard values.

"We want to enter a word of caution at this time: when a tube test is conducted it is absolutely essential that the filament potentials be adjusted accurately and exactly the same for all tubes in order that the readings obtained may be relied upon."

The serviceman is often called in to shoot trouble on a strange receiver—a set with which he is not over-familiar and one for which the owner has mislaid all operating and circuit data. On such jobs, when the trouble is not obvious, the serviceman's first task is to trace the leads—identifying the coded network of wires as those leading to definite supply voltages.

The extent to which this deciphering can be expedited often determines the efficiency with which the repairs can be effected.

We should like from our readers a description of the systems, if any, recommended for the rapid identification of unknown leads.

—THE EDITOR.

readings obtained on this meter under different control-grid conditions that the actual operating worth of a tube is determined. In the average tube-tester this change in control-grid condition is obtained by means of a specially provided button. With the button up, we have a certain definite grid voltage condition

A Portable Service Laboratory: WALDO TODD PRATT, West Hartford, Connecticut, specializing in Radiolas, is one of the service school that believes in doing the job on the spot. To work effectively on almost any job outside of his shop, he has accumulated the automobile laboratory, shown in the picture on this page and comprising the following equipment:

1. (At left) Phonograph turntable and pickup, for demonstration, and audio tests.

2. (Above) Western Electric 540w for checking loud speakers.

3. (Next to turntable) Phonograph records.

4. (Above) Oscillator. This has the necessary connectors, with suitable cords, to run as

(A) a.c. with 60-cycle modulation from lighting outlet.

(B) d.c. plugged into tube testing socket of Jewell No. 117 kit, which thus provides readings of filament voltage and plate current. This provides

(1) Modulated oscillation, 550 kc. to 1500 kc.

(2) Unmodulated oscillation, 550 kc. to 1500 kc.

(C) An external socket is provided whereby tubes may be "matched" by noting the filament voltage at which they go into oscillation.

5. Radiola 26, altered to



The portable service laboratory of Waldo Todd Pratt, which makes it possible for him to carry on almost any service work under the actual conditions experienced by the set user.

detect either radio or audio signals and noises. Used for checking reception and locating noises.

6. Jewell No. 117 test kit, and tool kit. This is standard except for connection to connect grid and plate of tube together, to note total emission.

7. (Above) No. 199 Analyser. Pratt maintains (with considerable logic) that he "has always had best success in testing and adjusting sets in the location and under the conditions in which they are to be operated."

Data on Eveready sets: GEORGE W. BROWN, radioservice manager, Motor Supply Company, Boston, Massachusetts, distributors of Eveready, sends along this concentrated service data:

"I am submitting a few troubles and their solutions as I have found them in the 1929 Eveready Set. In many instances they will apply to receivers in general.

COMPLAINT SOLUTION

No C Bias—Bad 327 tube. Open volume control or resistor. Cathode lead off.

Noisy Set—Set screws on variometer loose. Shields loose.

No plate voltage—Connection broken at terminal strip in box. Plate lead off.

Oscillation—Shields on r.f. coils loose. Detector shield loose. Bad tube. Antenna Compensator has no effect—Antenna too long. If over 20 feet should be connected to the long antenna binding post.

Volume control has no effect—Bad 327 tube.

Dynamic loud speaker does not work (Table model)—Open output transformer.

"The Eveready table model loud speaker will not work on the Console model set and visa versa. The table model set has a 1-1 ratio output transformer, and the table model loud speaker has a 25-1 ratio transformer but the console loud speaker is not equipped with a output transformer. Some dealers have returned loud speakers because they did not know this."

Testing receivers without equipment: A few pithy oscillations come from A. H. Goud, of South Portland, Maine:

"Much has been written about servicing equipment of all kinds, and every serviceman desires to acquire all the apparatus possible, to make his work easier and more accurate.

"However, emergencies do arise, and sometimes the serviceman finds himself empty handed, confronted by a balky set, with nothing but gray matter to guide him. There are quite a few tests that may be made with no equipment at all. At least, if the real trouble is not found on the spot, these preliminary tests are very helpful.

"Suppose the serviceman is asked to diagnose the trouble in an electric set. He may follow the procedure described below:

"If the set is dead: Turn on the current and wait about two minutes. Feel of the

power tube or tubes. If they are cool, there is no plate voltage on them, or a very low voltage. This would naturally suggest a blown filter condenser as the first possibility. In order to check this, place the hand on the rectifier tube. If the tube is very hot, the condenser is blown, or the wiring is shorted. Shorted elements in any of the tubes will cause trouble, and may be located readily by tapping the tubes and listening for the tell-tale crack-



George W. Brown in the service laboratory of the Motor Supply Company, Boston, Mass. The Radio Broadcast a.c. tube tester and modulated oscillator are among the prominent pieces of equipment in this laboratory.

ling noise. If the rectifier tube is cooler than usual, an open circuit in the B-supply circuit is indicated.

"If the tone quality is poor, and upon feeling of the power tubes, they are found to be very hot, there is no C-bias voltage.

"Continuing with the tests on the dead set, place the hand on the detector tube, or touch the grid leak. A hum indicates that the detector and audio system is ok. Now try tapping the antenna wire on its binding post. If the audio system is ok., and this tapping does not produce clicks in the loud speaker, the trouble is localized in the radio-frequency system. If clicks are heard, the trouble is probably due to loss of pickup caused by weak tubes, condensers out of resonance, open grid suppressor, or bad joints.

"When an analyzer is at hand, these tests are often convenient before it is used."

Number of servicemen in average shop: A recent survey made by the National Radio Institute, at Washington, D. C., showed that the average radio dealer in the United States employs four servicemen. The survey also indicates that 17 per cent. of the dealers contract for their service and repair work to be handled by outside service organizations.

New radio service school: John F. Rider, radio writer and well-known service consultant, has opened a service school at 1991 Broadway, New York City. Mr. Rider is teaching radio servicing both to attending and correspondence classes. The course is divided into two grades, an elementary course of five months and an advanced course for two months.

Electrifying Old Sets

"In reference to the modernizing of older types of battery-operated sets referred to in the August issue, we have done a large amount of this work and feel that we are qualified to give a little information on the subject, as all the sets we have powerized to date have given excellent results.

"Practically all work of this type has come to us through new set prospects who have been interested in the lower-

priced a.c. sets and who are the owners of high-grade battery sets, such as Zenith, Stromberg, Federal, etc. These prospects are attracted to the lower-priced sets by the convenience of a.c. operation; otherwise we usually find them satisfied with their present equipment.

"To offer the owner of a \$400.00 Stromberg-Carlson set a \$40.00 allowance on, for example, a Radiola No. 44 results in his leaving your place of business in a huff; yet that is about as high as a dealer can go on a set of the type of the R. C. A. No. 44.

"We usually suggest to the owners of these sets that they let us make an a.c. set out their present job. We explain that their set can be made as convenient as the current models and they usually take us up. If their present set is equipped with a B-power supply the cost to the customer will be \$40.00 for a six-tube set, and correspondingly higher as the number of tubes increase. If a B-supply unit is not used in the present installation, the cost to the customer will be from \$60.00 up, depending on the number of tubes.

"For this work we use the equipment of the Radio Receptor Corporation and the type apparatus usually required is the Powerizer Jr. A and C or the Powerizer Jr. A, B, and C. On the first type the list and cost prices are as follows:

	List	Cost
Powerizer A and C	\$12.00	\$ 7.20
Adapters	3.00	1.80
Tubes	12.00	7.20
Harness	5.00	3.00
Miscellaneous	2.00	1.20
Labor	6.00	2.00
Total	\$40.00	\$22.40
Profit		\$17.60

"On sets using the Powerizer A, B, and C the list and cost prices are as follows:

	List	Cost
Powerizer A, B, and C	\$35.00	\$21.00
Adapters	3.00	1.30
Tubes	15.00	9.00
Harness	5.00	3.00
Miscellaneous	2.00	1.20
Labor	0.00	2.00
Total	\$60.00	\$37.00
Profit		\$23.00

"In many cases this price can be reduced by making our own harness and some sets require no additional volume control or reneutralization which further reduces our cost. Wherever practicable we solder the adapters to the original socket prongs. We also short the original 1 A- and C-battery leads, as the powerizer is equipped with a variable C-bias resistor and this we balance to the B-supply used.

"We limit our efforts in this field to the better grade of sets and discourage the making of this change in the lower priced units. Our record in this field to date is 96 Stromberg Carlsons, 7 Kolsters, 8 Zeniths, 4 Bosch, and 2 Atwater Kents, a total in all of 117 sets. No changes were made or found necessary in the audio channels of these sets."

B. B. ALCORN, Kew Radio Electric Inc., Kew Gardens, L. I.

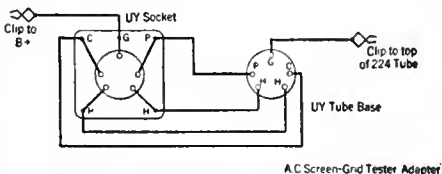

Fig. 1—The d.c. screen-grid tester adapter.

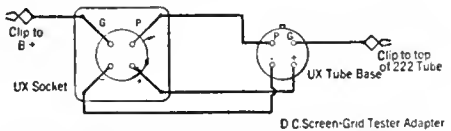
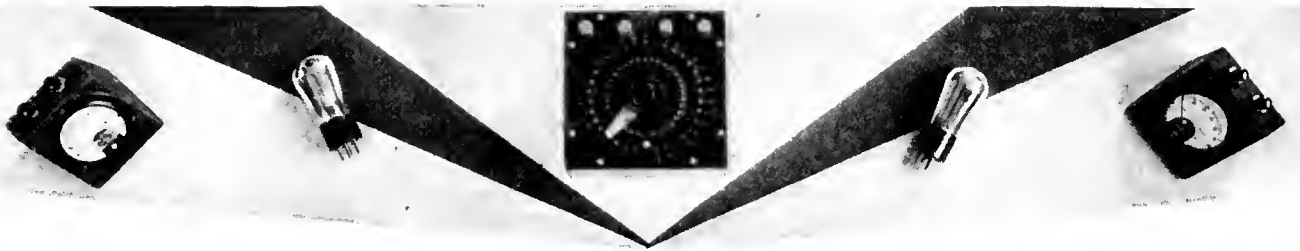

Fig. 2—The a.c. screen-grid tester adapter.



STRAYS FROM THE LABORATORY

A.R.C. Radio Altimeter

The picture herewith shows a special indicator panel installed in the pilot's compartment of a Fokker cabin monoplane, one of several planes employed in performance studies on the reflection altimeter of the Aircraft Radio Corporation, one of the Boonton (N. J.) Associates. The series of studies, continuing over many months, has included investigations of the effect of different wavelengths, antennas, airplane constructions, soils, topography, weather, and obstructions on the ground. The commercial form of the device can be made to give its indications by a needle traveling over a calibrated scale or by a sequence of lamps, each of which lights at a predetermined height above the ground or water over which the plane is traveling. In the experimental installation shown in the picture, the functions have been divided for ease of obtaining data. Two indicating instruments are provided, each of which is illuminated by a colored lamp, the two lamps lighting alternately at predetermined heights above ground. The height can be read from the instrument which is at the moment illuminated. The dial below the center of the panel enables the observer to make a balancing adjustment which is useful during tests on the effect of voltage variation, tube ageing, and the like.

Linear Detection

An interesting advantage of linear detection, as pointed out by Professor Terman in this issue of RADIO BROADCAST is its ability to discriminate automatically against unwanted signals weaker than the desired signal. Fig. 1 shows how this occurs. At (a) is the weak undesired envelope, in (b) is the desired envelope. These are envelopes of inaudible carriers and the beat note between these carriers must be inaudible; i.e., the two signals must differ by more than 10,000 cycles. The first thing that happens, then, is the production of an inaudible beat frequency. When the envelopes are in phase this beat frequency has a high amplitude; when they are out of phase, the amplitude is low. Thus the amplitude of the beat frequency varies between (c) and (d) in Fig. 1. The average value of this change in amplitude is the desired audio signal. If there is any non-linearity the increases (say) above this average will be greater than the decreases below this average and thus the undesired weak signal will affect the desired strong envelope.

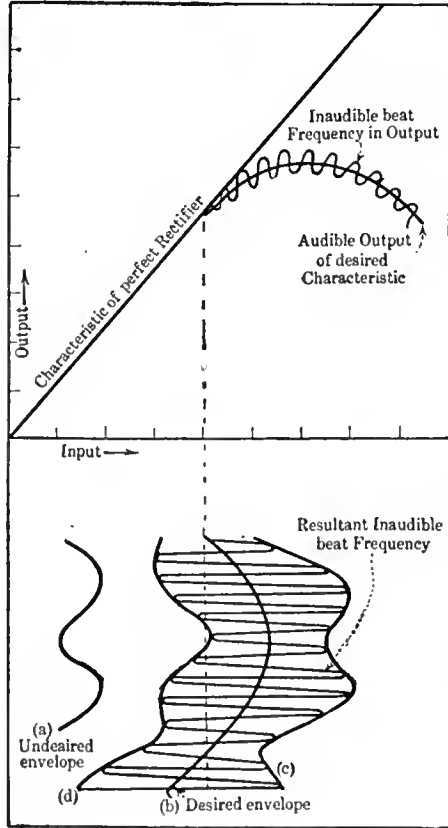
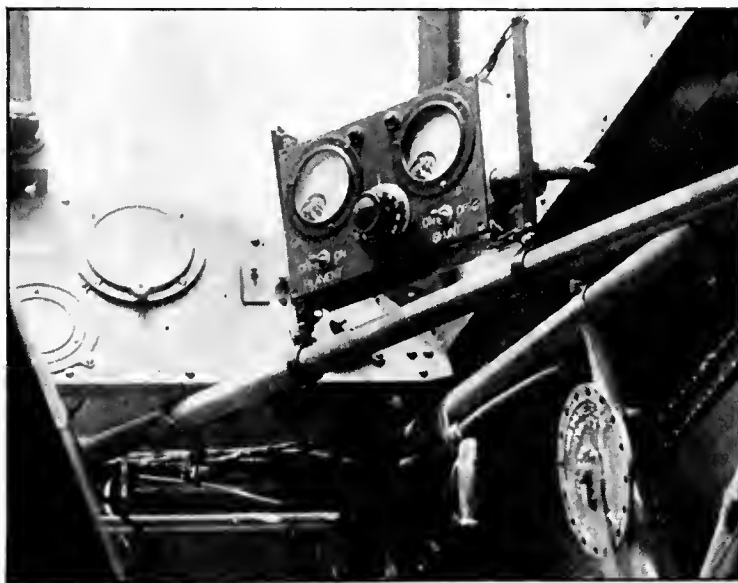

Fig. 1

Thus it appears that not only is the linear detector advantageous from the standpoint of decreased harmonics, from which the square-law detector suffers, but it is a sort of interference



View of radio equipment employed in experiments with the reflection altimeter.

eliminator too. Static may be reduced by the use of a linear detector, providing the modulation of the desired carrier signal is sufficiently great.

Advice to Students

Robert S. Kruse—who doesn't know Kruse?—has written the following letter to a reader who wants to be a radio engineer. Every word of it is true.

"No school does, or can, educate a man to be an engineer—it can only give him fundamental principles and general methods of thought and action to use as tools in attacking the special problems he meets. Problems are all special in one sense or another and no book can anticipate everything that progress brings. If such a handbook were possible we would always find the answer in a handbook, and engineering staffs could be replaced by a five-foot shelf of books.

Manifestly this is not the way things are—we do not anticipate and congeal our methods into a handbook. Instead we train men who regard the handbook as a toolrack in which concrete facts are stored but who themselves see to the use of the tools—and forge new ones as the need arises. These men are our researchers and engineers. The former deals with things exclusively—with the use by man not a controlling factor—the latter works constantly with things and men as applied to the pressing immediate needs of men.

If you wish to enter either of these two fields, learn all the mathematics you can, see all the radio equipment of any sort (it is all within 30 miles of you) and handle all you may of it, operate an experimental station of your own (but do it studiously and not as a social activity or a fad), attend I. R. E. meetings and make all possible personal contacts, and above all learn how people think, feel, and act, for the greatest danger that confronts the student engineer is that in learning how to deal with scientific things he loses contact with people—without whose aid he is useless."

Screen-Grid Ratings

Although the rating on the screen-grid tube has not been changed, we understand that the majority of set manufacturers using this tube are fixing their own control- and screen-grid voltages. With a 1.5-volt negative bias the control grid in good tubes begins to draw current at about 0.8-volt negative. This means that an incoming signal of about 0.7-volt peak would cause the grid to take current and its input resistance to

(Concluded on page 60)

Report on Experiments With Units of Various Designs

CHARACTERISTICS OF A.F. TRANSFORMERS

By PROF. H. M. TURNER

Sheffield Scientific School, Yale University

AS A RESULT of the keen competition among manufacturers, stimulated by the demand of the radio public for better and better quality, there has been marked improvement in the performance of audio-frequency transformers during the past few years. The subject has been extensively investigated by competent research engineers and designers but the results of their studies come to us in the form of the finished product with little information as to the exact changes that have brought about improved performance. There is in no sense a criticism of the manufacturer, for such information is his stock in trade. However, one of an inquiring mind desires to know in what way and to what extent the characteristics are modified by changes in design or operating condition.

What constitutes a good transformer? This, of course, depends upon the use that is made of it. For broadcast reception of music, the primary consideration is quality or faithful reproduction which requires, assuming an ideal loud speaker, that the amplification be essentially independent of frequency over some predetermined band, say from 30 to 8000 cycles. However, with commercial loud speakers, considerable departure from a flat characteristic is permissible, and in some cases even desirable, in order to compensate deficiencies in the reproducing unit. For telegraph purposes the primary consideration is intensity or large amplification. The band may be much narrower, say from 800 to 1200 cycles, for a peaked characteristic is quite desirable in that it may be made to give a louder response to the desired signal and at the same time greatly reduce interference from neighboring channels.

Unfortunately it is not always possible to obtain excellent quality and high amplification from the same transformer. The response characteristic of transformers, however, may be modified materially by design and operating conditions as follows: the amount of iron in the core; the ratio of turns; the actual number of turns in the windings and their position with respect to each other and to the core, that is, whether the windings are interwoven or the primary or secondary is placed next to the core; the total resistance of the plate circuit; the plate voltage and grid bias of the amplifying tube associated with the primary of the transformer; and, to some extent, the capacity in parallel with the primary and secondary.

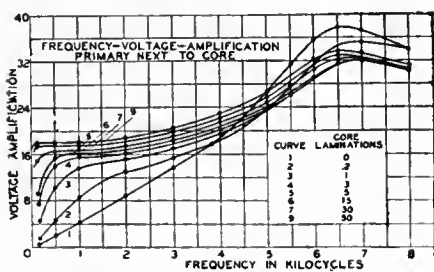

Fig. 4

Object of Investigation

The object of this paper is to report on some experiments on audio-frequency transformers of different design and operated under widely different conditions with the hope of at least partially answering some of the questions that occur to one but which in some cases remain un-

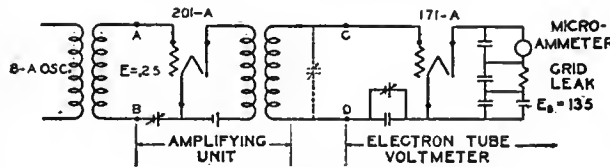

Fig. 1

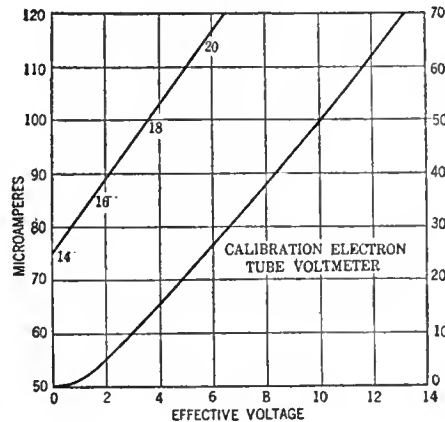
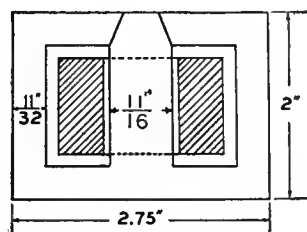

Fig. 2

answered due to lack of time or adequate facilities for conducting the necessary experiments. No attempt is made to define or to determine an ideal transformer but rather to show the effect produced upon the amplification characteristic by certain changes many of which are far removed from those encountered in practice.



CORE LAMINATION

Fig. 3

Faithful reproduction is dependent not only on the transformer but also on the associated amplifier, loud speaker, and the response characteristics of the receiving ear. But, since the imperfection of the latter are present whether one hears the original program or a loud speaker reproduction, it may be left out of consideration here. Although the ear must be the final judge of both quality and intensity it is not a satisfactory instrument for labora-

tory determinations. In the first place the ear, although sensitive to changes in pitch, is quite tolerant of changes in intensity; in other words, variations of 10 to 20 per cent, or more may take place without being perceived. This is fortunate for, if the response were directly proportional to the stimulus, an organ of hearing sufficiently sensitive to catch the slightest whisper would be destroyed by sound waves of great intensity, or at least they would be a source of great pain. In the second place there would be disagreement among observers. Differences that would be apparent to a trained ear would be entirely overlooked by one less discriminating. Even the results obtained by a given observer vary from day to day. Thus, for measurement purposes the ear cannot be considered an instrument of precision and for this reason an electron-tube voltmeter was used to measure the amplification as determined by the output voltage of the transformer and its associated amplifying tube.

The Electric Circuit

The circuit arrangement that was used is shown in Fig. 1. A variable frequency is obtained from an 8A oscillator whose output transformer at the left supplies a voltage which is maintained at a constant value, usually 0.25 volt to the grid of a 201A amplifying tube in the plate circuit of which is connected the primary of the transformer. The secondary or output voltage being measured by an electron-tube voltmeter of the type developed by E. T. Dickey of the Radio Corporation. The condenser across the secondary of the transformer, shown dotted, was introduced in some of the experiments to be referred to later.

The Magnetic Circuit

Where the transformers were assembled in the laboratory, a core of 15 mil hipernik was used, the other dimensions being given in Fig. 3. In all cases, unless otherwise indicated, the core consisted of 50 laminations, the exception being Figs. 4 and 7 where the amount of iron was varied.

Series I: This transformer consisted of a primary of 7000 turns of No. 40 enameled wire having a resistance of the order of 2400 ohms and a secondary of

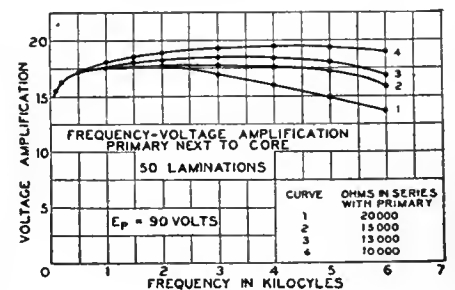

Fig. 5

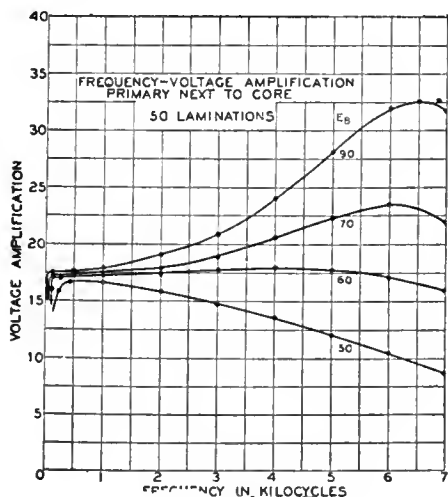

Fig. 6

15,000 turns of No. 40 of 7100-ohms resistance wound over the primary. The overall voltage amplification (Fig. 4) of the 201A tube and the transformer was measured for frequencies from 200 up to 3000 cycles, first with a core of 50 laminations and then with 30, 15, 5, 3, 1, 0.2, and 0 laminations. It will be observed that the removal of most of the iron has a relatively small effect upon the amplification over the greater portion of the frequency range, however, the effect of the core is rather pronounced at the low frequencies. Therefore, in order to retain the low notes a considerable amount of iron is required in this particular transformer. By 0.2 of a lamination is meant that portion of a single lamination which passes through the opening in the coil and which has a length equal to that of the coil or approximately one inch. The increased amplification due to this small amount of iron over that with no iron at all is pronounced below 200 cycles. Above 4500 cycles, regardless of the number of laminations, the core has practically no effect on the amplification other than to prevent an over exaggeration of the higher frequencies. Regardless of the amount of iron the maximum amplification occurs at 6500 cycles which is rather surprising and indicates that the introduction of iron does more than merely increase the induction. The maximum amplification is approximately twice that of the lower frequencies.

The form of the curve suggests a resonance effect which is due to the distributed capacity of the secondary and the grid-filament capacity of the tube to which it is connected. It is evident that the introduction of resistance in the primary circuit would tend to flatten out this curve and make the amplification much more uniform throughout the frequency range, and this is confirmed by Fig. 5.

A change of plate voltage would have something of the same effect as shown in Fig. 6 as this will change the internal resis-

tance of the tube. A decrease in plate potential from 90 to 67.5 volts for a 201A with normal grid bias causes an increase in plate resistance from approximately 10,000 to 14,000 ohms and at the same time decreases slightly the amplification factor. A decrease of plate potential from 67.5 to 45 volts would increase the resistance from 14,000 to 18,000 ohms. There are certain other factors that will have a secondary effect.

Series II: The primary of this transformer has 5000 turns of No. 40 wire with

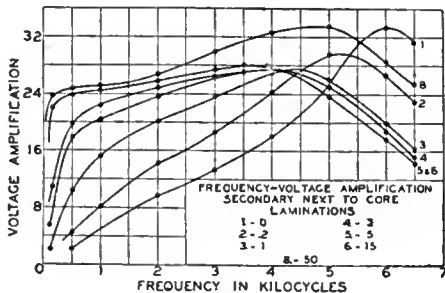

Fig. 7

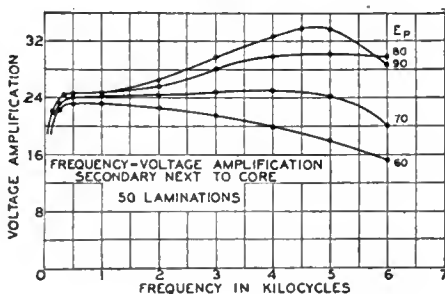

Fig. 8

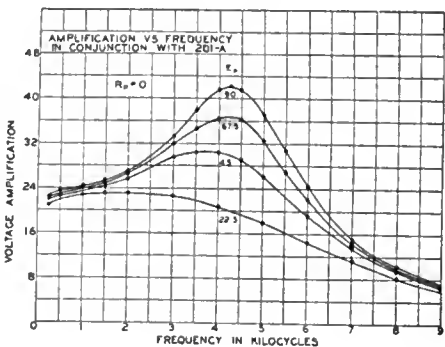

Fig. 9

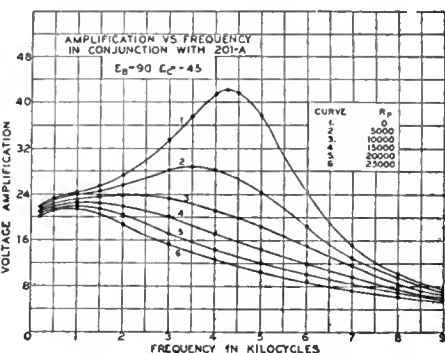

Fig. 10

a resistance of 2500 ohms. The secondary has 15,000 turns of No. 40 wire with a resistance of 6100 ohms. The amount of iron was varied as in Series I but the general appearance of the curves is quite different. There is a more pronounced spreading of the curves (see Fig. 7) and the maximum points occur at different frequencies, the maximum amplification for

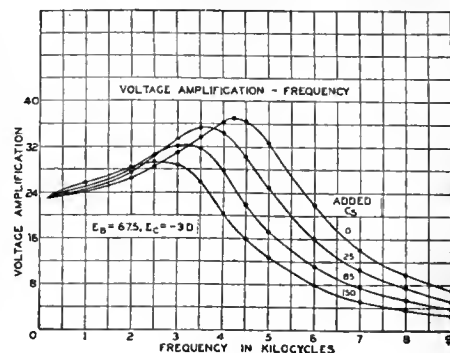

Fig. 12

the air core occurring at 6000 cycles. Introducing iron has the general effect of lowering the frequency at which the peak occurs. As the amount of iron was increased the maximum came at 5200, 4500, 4000, 3500, and then increased to 4800. The difference between this series and the last was due largely to the increased capacity of the secondary winding which was placed next to the core. Another possible difference was due to a change in leakage reactance. There is also a greater spreading of the curves for the different values of plate voltage (see Fig. 8) than for the corresponding case where the primary was wound over the secondary.

Series III: This is a commercial transformer for which there is no information regarding the number of turns or the turns ratio, but the ratio is probably between 2.5 and 3 as indicated by the amplification at the lower frequencies. The primary resistance is approximately 2000 ohms and the secondary 7500. It is considered a high-quality transformer. Figs. 9 to 13 show the effect of changing the plate voltage, adding resistance in the plate circuit, and varying the capacity across the secondary of the transformer for three different values of plate voltage with normal bias in each case. It should be noted that the effect of adding capacity is to decrease materially the amplification at the higher frequencies. The fact that the amplification varies considerably with frequency does not necessarily indicate that the quality will be poor. The maximum amplification for normal plate voltage and grid bias occurs at 4200 cycles and is approximately twice that at low frequency.

Series IV: This is a commercial transformer having a 6:1 ratio and giving an amplification of approximately twice that of the last transformer at low frequencies. The increase of amplification with frequency is less pronounced than for the last transformer, the maximum being about 30 per cent. greater in this case, although, due to the larger distributed capacity, it occurs at 3200 cycles and decreases quite rapidly for frequencies

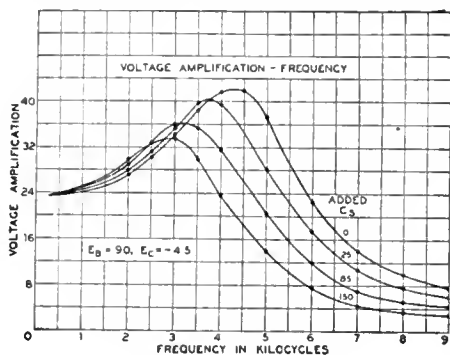

Fig. 11

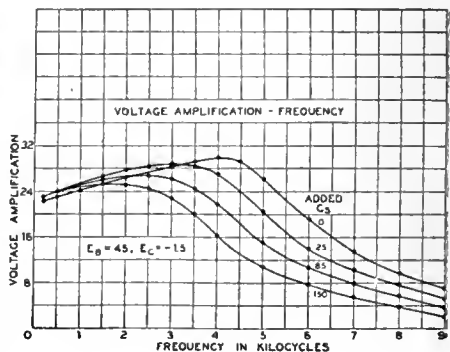

Fig. 13

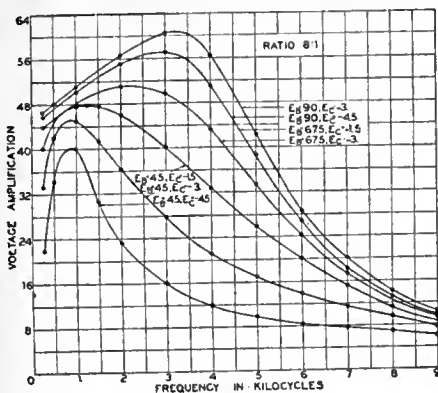

Fig. 14

above this value. The primary resistance was 1300 ohms and the secondary 12,000.

The effect of a change in either plate voltage or grid bias materially modified the shape of the characteristic, as shown by Fig. 14. The amplification increased with an increase of plate voltage and a decrease of negative grid bias. For a plate potential of 45 volts and a grid bias of 3 volts the curve rises rapidly to a maximum and then decreases rapidly to a very low value as the frequency is increased.

Series V: The five transformers here compared have the constants given in Table I on this page.

A comparison of the three transformers having 5000 turns in the primary and 15,000, 20,000, and 25,000 turns in the secondaries, respectively, is given in Fig. 15. There are two curves for each transformer but for the present consider only the higher one which is for normal conditions of operation. At low frequencies the amplification is almost exactly proportional to the number of turns in the secondaries but as the frequency is increased the amplification gradually increases to a maximum of approximately 175, 150, and 115 per cent. of the low frequency values and then decreases quite rapidly. These transformers, reach their maximum amplification at 6000, 4000, and 3000 cycles, respectively. It happens that the first and last transformers have almost exactly the same average amplification over the nine-kilocycle band while the intermediate one has a somewhat higher average and on the whole is probably the best. Although the average amplification is not necessarily the best measure of a transformer, especially if taken over a wide

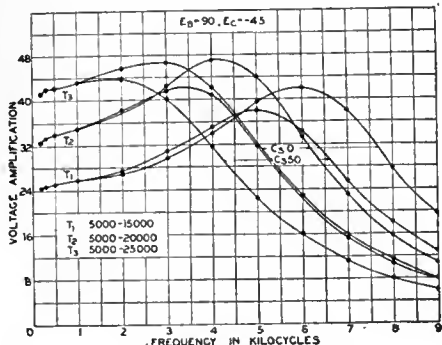

Fig. 15

band of frequencies, frequencies below five thousand may be far more important in some cases than those above. An added capacity of 50 mmfd. across the secondary has slight tendency to increase the amplification at certain frequencies. This tendency, which is greatest in the case of the low-ratio transformer, is negligible for the intermediate, and vanishes for the high ratio. Above a certain frequency, depending on the transformer, there is a marked decrease in the amplification due to the added capacity indicating the desirability of keeping the distributed capacity of the secondary and the capacity of the leads as small as possible.

Different Turns Ratios Compared

In Fig. 16 are compared transformers having a ratio of 3:1 with primaries of 5000 and 7500 turns and transformers having a ratio of 5:1 also with primaries of 5000 and 7500 turns. It will be observed that the cut-off is much more marked in the case of the high-ratio transformers. This is due largely to the increased distributed capacity of the secondaries as indicated in Fig. 15. In the case of the 5:1 transformer with the 7500-turn primary, the

Transformer Equations

$$(1) R_{eq} = R_1 + \frac{W^2 M^2}{Z_2^2} R_2 \quad (2) X_{eq} = wL_1 - \frac{w^2 M^2}{Z_2^2} \left(wL_2 - \frac{1}{wC_2} \right)$$

$$(3) I_1 = \frac{E_1}{\sqrt{\left[R_1 + \frac{w^2 M^2 R_2}{Z_2^2} \right]^2 + \left[wL_1 - \frac{w^2 M^2}{Z_2^2} \left(wL_2 - \frac{1}{wC_2} \right) \right]^2}}$$

$$(4) E_2 = \frac{E_1 M / C_2}{\sqrt{R_2^2 + \left(wL_2 - \frac{1}{wC_2} \right)^2} \sqrt{\left[R_1 + \frac{w^2 M^2 R_2}{Z_2^2} \right]^2 + \left[wL_1 - \frac{w^2 M^2}{Z_2^2} \left(wL_2 - \frac{1}{wC_2} \right) \right]^2}}$$

$W = 2\pi f$

Table I

	T ₁	T ₂	T ₃	T ₄	T ₅
Ratio	3:1	4:1	5:1	3:1	5:1
Primary turns	5,000	5,000	5,000	7,500	7,500
Secondary turns	15,000	20,000	25,000	22,500	37,500
Primary resistance	1,750	1,750	1,750	6,200	6,200
Secondary resistance	7,300	13,500	27,000	25,000	46,000
Size of wire	40-40	40-41	40-44	44-44	44-44

cut-off is at 2000 cycles and is quite sharp. In Fig. 17, the same comparison is made but with 45 volts on the plate, and this shows that there is considerable difference between the characteristics for the two plate voltages.

In analyzing these curves in greater detail than time will permit here it will be helpful to recall the equations for the equivalent transformer constants. Where the primary of a transformer has resistance and inductance but negligible distributed capacity and the secondary has resistance, inductance, and capacity which includes the distributed capacity of the secondary and that of the leads and grid-filament of the associated tube, for the sake of simplicity, taken as a fixed value across the secondary, and further that the mutual capacity between the two windings be neglected, one may replace the transformer with an equivalent resistance and reactance in so far as the plate circuit of the amplifying tube associated with the primary is concerned. The equivalent constants then have the values indicated by equations (1) and (2).

For the low values of frequency and the capacity usually associated with the secondary, the total reactance of the secondary is capacitive and when transferred to the primary has the effect of increasing the equivalent inductive react-

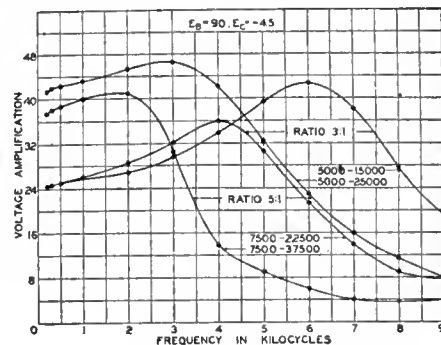

Fig. 16

ance and, therefore, tends to cause a larger portion of the total amplified voltage in the plate circuit to be consumed by the induced electromotive force of the primary, and, therefore, a greater induced electromotive force in the secondary. The primary current may be found from equation (3) and the secondary current is:

$$I_2 = \frac{\omega M I_1}{Z_2}$$

and what we are more concerned with is the voltage across the terminals of the secondary which is given in equation (4). For low frequencies ωL_2 is less than $1/\omega C_2$ and as the frequency is increased these two factors approach equality until a condition of resonance is reached in the secondary and the first radical in the denominator decreases to a minimum value of R_2 as a result of which a large output voltage is obtained. As the frequency is further increased ωL_2 is greater than $1/\omega C_2$ and the denominator increases, thus reducing the output voltage.

An increase of secondary capacity due to the added condenser causes the condition of resonance to be reached at a lower frequency after which the output voltage decreases rapidly as may be seen from the equation. These results will be somewhat modified by the mutual capacity between the two windings of the transformer.

Bibliography

JOHNSON: *Transmission Circuits for Telephone Communication*. D. Van Nostrand Co.
 CASPER: "Telephone Transformers," *American Institute of Electrical Engineers*, March, 1924.
 MARTIN AND FLETCHER: "High-Quality Transmission and Reproduction of Speech and Music," *American Institute of Electrical Engineers*, March, 1924.
 KELLOGG: "Design of Non-Distorting Power Amplifiers," *American Institute of Electrical Engineers*, May, 1925.

—The Editor.

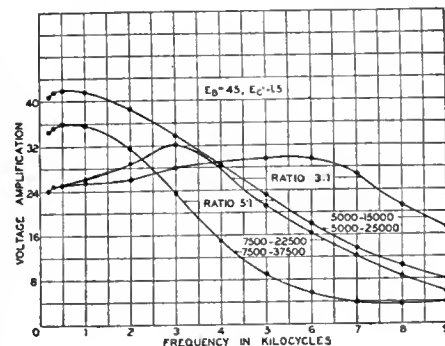

Fig. 17

DESIGNING THE POWER SUPPLY CIRCUIT

By RICHARD F. SHEA

Engineering Department, Atwater Kent Manufacturing Company

THE DESIGN of power-supply systems is an essential part of radio engineering. To be sure, it relies less upon the precise type of measurement which is characteristic of r.f. design, but in its place we find a great need for practical design, "cut-and-try" methods if you wish. It is the purpose of this paper to point out some of the practices and methods entering into this branch of radio engineering.

Let us then start at the beginning and follow through the procedure necessary to turn out a completed power-supply unit for a certain receiver and associated parts. Since the requirements depend upon the equipment used in conjunction with this supply unit, we must have previous knowledge of the type of set, voltages desired at the tubes, number and type of tubes, type of loud speaker, and, if a dynamic loud speaker is to be used, the voltage and current required to excite properly the field coil. Let us take a set which is fairly typical of the modern receiver. This set employs three stages of r.f. using screen-grid tubes requiring, let us say, 135 volts on the plates, 1½ volts on the control grids, and a maximum of 50 volts on the screen grids. The detector is of the C-bias or plate-rectification type requiring 120-130 volts on the plate and a grid bias of 12 volts. The first audio tube is a 227 type operating at 135 volts on the plate and a 6-volt grid bias. In the power stage 250-type tubes in push pull are used, requiring 425 to 450 volts on the plates and a bias of 70-85 volts. The speaker is a dynamic type, with a 5000-ohm 70-mA. field.

First Considerations

Let us now tentatively lay out our power pack as shown in Fig. 1. For convenience only, the 250-type tubes have been shown connected to the power supply, the other tubes going to the voltage-dividing resistor.

We can now compute the desired voltage across condenser C₂. We want 450 volts on the plates of the 250's and 84 volts on the grids. Reference to tube tables indicates a plate current of 55 mA. for a 250-type tube under these conditions—a total drain of 110 milliamperes for the two tubes. If our output transformer's primary has a resistance of 500 ohms on each side, our drop there will be 25 volts. Our required voltage at C₂ then is 450 + 25 + 84 = 559 volts. The bias for the 250-type tubes is obtained from the resistor R_c between the center tap of the filament winding for the 250-type tubes and the ground. This resistor, R_c, can be calculated immediately, knowing the drop across it and current flowing through it—

$$R_c = \frac{84 \times 1000}{110} = 765 \text{ ohms.}$$

Now, since we know the desired current through the field coil and its resistance, we can compute its voltage drop as—

$$V_f = \frac{5000 \times 70}{1000} = 350 \text{ volts}$$

It must be stated here that all resistors are to be measured *hot*, after the appara-

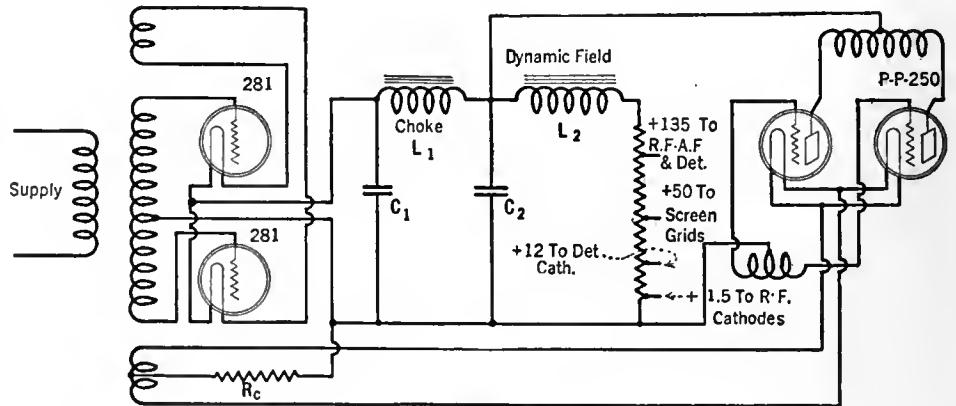

Fig. 1

tus has been in use from one half to one hour.

Knowing our voltage at C₂ and our field drop, we can compute the available voltage at the divider as 559—350 = 209 volts.

Let us consult Fig. 2 which shows an enlarged diagram of the divider resistor. From this we can calculate the resistance values of the various units. We have a total of 70 mA. fed to the divider and this splits up between the tubes and the resistor according to the characteristics of the tubes. Let us refer again to our tube tables and find the plate current for the screen-grid tubes, the 227 as a detector, and the 227 as an audio amplifier. We get, respectively, 2 mA., 2 mA., and 3 mA. The three r.f. tubes then will draw a total of 6 mA. and the total of r.f., detector, and a.f. plate currents will be 6 + 2 + 3, or 11 mA. The current at the + 50-volt tap is very low as this feeds the screen-grids, at the 12-volt tap the 2 mA. returns from the detector cathode, and at the 1½-volt tap the 6 mA. returns from the r.f. tubes. The audio tube is supposed to be biased in a manner similar to that employed for the 250-type tubes, whereby the grid voltage is obtained from a resistor in series with the cathode lead. Consequently, the plate current from the audio tube returns to the ground point and does not flow through the divider.

Our resistances now have the voltages and currents shown and can be computed easily—

$$R_1 = \frac{74}{0.070} = 1059 \text{ ohms}$$

$$R_2 = \frac{85}{0.059} = 1440 \text{ ohms}$$

$$R_3 = \frac{38}{0.059} = 644 \text{ ohms}$$

$$R_4 = \frac{10.5}{0.061} = 172 \text{ ohms}$$

$$R_5 = \frac{1.5}{0.067} = 22.4 \text{ ohms}$$

Thus we find that our divider is a resistor of 3337 ohms, tapped at 22, 191, 838, and 2278 ohms.

Selecting the Choke

Having gone this far, our next step is to choose a proper size of choke coil. Most manufacturers have standard sizes of chokes and the problem becomes one of picking a choke that will not have an excessive heat rise under the current, which is 110 + 70, or 180 mA. (a rather high current for two 281-type tubes to handle—*Editor*). Of course, the higher the inductance, the better will be our filtering, for given condenser values, and, conversely, if we use a small choke coil we must expect to use large values of filter capacity to obtain satisfactory filtering. The relationship between capacity and choke size is largely economic and each manufacturer has his own answer to the question.

Having chosen our choke coil, the biggest we can use economically, and knowing its resistance, we compute the drop in it. Let us say this resistance is 300 ohms. Then our drop is 300 × 0.180 = 54 volts and we now have the load our rectifiers must supply, as the voltage across condenser C is 559 + 54 = 613 volts and the current drain will be 180 mA. It now remains for us to determine the proper secondary voltage to be applied to the rectifier tubes in order to obtain this required load. For this purpose we use characteristic rectifier tube curves, such as shown in Fig. 3. These curves show variation in output voltage, against load, for

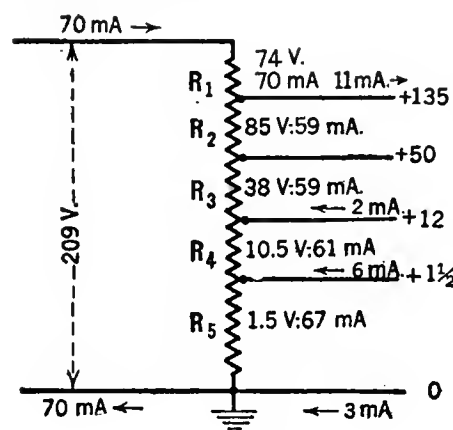

Fig. 2

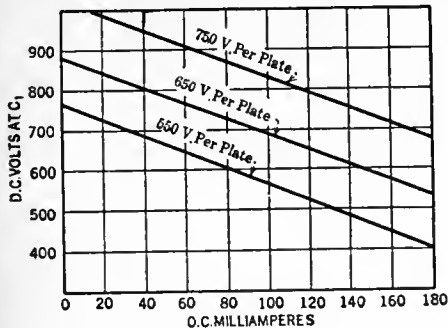

Fig. 3

a fixed value of C_1 and various secondary supply voltages. Referring to these curves, we can determine the required secondary voltage and we will then be ready to design our transformer. Here we must use some previous experience to tell us approximately how much capacity will be necessary at C_1 to secure efficient filtering. Let us try a value of 4 mfd. From the curves of Fig. 3 we find that a secondary voltage of 1400 volts is required to produce 613 volts at 180 milliamperes with 4 mfd. as the value of C_1 .

We are now ready to tackle the problem of transformer design, and it is here that practical rules and experience count very much as it is quite an art to be able to hit the nail on the head the first time. The "cut-and-try" method is used entirely in commercial practice, but a skilled designer can come within a very close margin on his first try.

Transformer Design

First we must tabulate our requirements in the way of approximate voltages and currents. Let us say our transformer is to work from a line of 115 volts at 60 cycles. We know our secondary voltage must be 1400 volts, and the load delivered by the rectifier tubes is $613 \times 0.180 = 110$ watts. Assuming an efficiency of about 75 per cent. for the rectifier tubes, we get 145 watts from the secondary winding. This tells us that our secondary current will be approximately 100 mA. We have the filaments of two 281-type tubes to light, each requiring 7.5 volts, or 15 volts at 1.25 amperes, or 18.8 watts; we have three screen-grid filaments to light at 2.5 volts, 5.2 amps, or 13.0 watts; two 250's, requiring 7.5 volts at 2.5 amps, or 18.8 watts, and two 227's, requiring 2.5 volts and 3.5 amps, or 8.8 watts. The total filament output is 58.3 watts and the total power is 203 watts. Assuming 90 per cent. efficiency, the input watts should be 225, and assuming 90 per cent. power factor, this gives a primary current of approximately 2.2 amps.

From the above we can choose our wire sizes, allowing 800-1000 circular mils per ampere for the inside windings and 600-800 circular mils per ampere for outside windings. This calls for approximately 1700 circular mils for the primary, or number 18 wire (see Fig. 4 for wire table). The secondary requires 80 circular mils or number 31 wire. The filament winding for the 281-type tubes requires 800 circular mils, or number 21 wire, all the 2½-volt filaments can be supplied from one winding with a consequent load of 8.75 amps, requiring 6000 circular mils, which can be obtained by using two number 15 wires in parallel. The filament winding for the 250-type tube requires 1700 circular mils, or number 18 wire. Thus we have the proper size of wire for all windings and are ready to compute the proper number of turns and the coil itself.

Most manufacturers have certain stan-

ard core sizes which are used for the various transformer jobs. Since the dies are already existent for these laminations it would be best to use the most convenient size, if it permits designing an economical and sensible transformer. In the event that a new lamination must be designed it is evident that the problem is entirely one of economics, i.e., balancing copper cost and iron cost to obtain the cheapest possible transformer. Occasionally space enters into the problem very forcibly, preventing one from realizing an ideal, and often making very weird shapes necessary.

The lamination shown in Fig. 5 illustrates a core shape that will be found quite desirable for a 60-cycle transformer of the sort needed in this specific job. If designed for 25 cycles more iron would be necessary and it would be advisable to increase all dimensions, thus allowing us to use more turns of wire and less iron than if the lamination of Fig. 5 were used.

It is obvious that if the cross section of the core were square the cost of winding the coil would be less and the space taken up would also make it more adaptable to the majority of jobs. Therefore, let us try a core 1½" square, an area of 3.06 square inches.

SIZE B.&S.	DIAM INCHES	AREA CIRCULAR MILS	
14	0.0661	4107	
15	0.0590	3257	
16	0.0526	2583	
17	0.0471	2048	
18	0.0419	1624	
19	0.0375	1288	
20	0.0335	1022	
21	0.0299	810.1	
22	0.0267	642.4	
23	0.0239	509.5	
24	0.0213	404.0	
25	0.0191	320.4	
26	0.0170	254.1	
27	0.0152	201.5	
28	0.0135	159.8	
29	0.0122	126.7	
30	0.0108	100.5	
31	0.0097	79.70	
32	0.0087	63.21	
33	0.0077	50.13	
34	0.0069	39.75	
35	0.0062	31.52	

Fig. 4

To obtain the proper number of primary turns we use the well-known formula—

$$E = 4.44 f NAB \times 10^{-2}$$

where f = Frequency in cycles per second
 A = Area in square centimeters
 N = Number of primary turns
 B = Flux density in lines per square centimeter
 E = Primary voltage

It can be shown that at 60 cycles a flux density of 10,000 to 11,000 lines per square centimeter is about correct, as more than that produces excessive core loss. Similarly, at 25 cycles we can use 12,000 or 13,000 lines per square centimeter. Substituting these values we obtain—

$$\text{At 60 cycles } \frac{NA}{E} = \frac{10^6}{4.44 \times 60 \times 10,000} = 37.5$$

$$\text{At 25 cycles } \frac{NA}{E} = \frac{10^6}{4.44 \times 25 \times 13,000} = 69.2$$

converting A to square inches this becomes—

$$\text{At 60 Cycles } \frac{NA}{E} = 5.8$$

$$\text{At 25 cycles } \frac{NA}{E} = 10.7$$

In ordinary practice we use the factors 6 and 11 to give us the proper flux densi-

ties, and this simplifies our design very considerably.

Returning to our problem at hand, we can now determine the proper number of primary turns, for 60-cycle operation, at 115 volts—

$$N_1 = \frac{6 \times 115}{3.06} = 226 \text{ turns}$$

In determining the secondary and tertiary turns we must make still greater approximation. The computation of the exact turns ratio depends upon a pre-knowledge of primary and secondary resistance and reactance, primary and secondary current, voltages, and power factors, and consequently is a very complicated process. Here it is best to use the results of experience and make a rough approximation. It will be found in the majority of cases that if the proper sizes of wire are chosen the ratio of turns will be only two or three per cent. higher than the ratio of voltages under load conditions. This, then, gives us a convenient approximation for turns ratio. We want a 1400-volt secondary with 115 volts on the primary, hence our turns

ratio will be $\frac{1400}{115}$ plus 2½ per cent. or $\frac{1400}{115} (1.025) = 12.50$. Since our primary

has 226 turns our secondary will need 12.50×226 , or 2700 turns. Similarly, we obtain the turns on the tertiary windings—

$$281 \text{ filaments. } N_{281} = 226 \times \frac{15.00}{115} \times 1.025 = 30.2 \text{ turns}$$

$$250 \text{ filaments. } N_{250} = 226 \times \frac{7.50}{115} \times 1.025 = 15.1 \text{ turns}$$

$$224 \text{ and } 227 \text{ filaments. } N_{227} = 226 \times \frac{2.50}{115} \times 1.025 = 5.0 \text{ turns}$$

Here it must be mentioned that this transformer is being designed for zero resistance cable, which, of course, is not obtained in practice. We must know our cable drop, and add this to the desired filament voltage in order to get the required voltage at the transformer.

We now have all the windings on our transformer—

Primary	226 turns of number 18 wire
Secondary	2700 " " " " 31 "
281 fil.	30 " " " " 21 "
250 fil.	5 " " " " 18 "
224 and 227 fil.	5 " " " " 15 " doubled

The secondary and the filament windings for the 250-type tubes must be center-tapped. Our next problem is to see whether this coil will fit inside the window in the lamination, leaving enough space for commercial variation. Here we return to our wire table (see Fig. 4) and note the

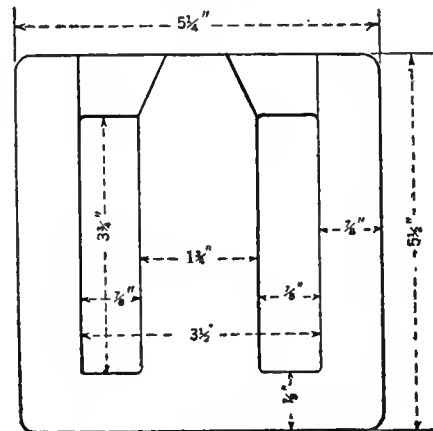

Fig. 5

diameters of the various sizes of enameled wire required. The computation of coil size follows—

core diameter	1.750"
allow 1/8" clearance	0.062"
	1.812"

We must choose the primary tubing from experience, and the choice is entirely one of rigidity, hence dependent upon the size of wire. Likewise, the choice of the paper between layers depends upon the size of wire more than upon break-down. The amount of insulation between leads and the body of the coil and between primary and secondary and the filament winding for the 281-type tubes and other windings depends largely upon break-down as well as mechanical requirements. Experience is the best guide in the choice of these values and the table in Fig. 6 give values that have been found satisfactory in transformer design. This table tells us that for our required primary of number 18 wire we will need a primary tube 0.080" thick, and an 0.007" paper between layers, preferably of gummed kraft.

The space taken by the primary winding is figured as follows—

No. 18 wire diameter (see tables)	0.0419"
Paper between layers	0.0070"
25 per cent. of paper added for varnish	0.0018"
	0.0507"
Add 10 per cent. for bow	0.0051"
	0.0558"

Then each primary layer will take up 0.0558", or will add twice this, or 0.1116", to the diameter of the coil. Inspection of Fig. 5 shows our coil can be 3 1/2" long, and this allows us a 3" winding space. We can compute the number of primary turns per layer by dividing the winding length by the wire diameter, and multiplying by the space factor, which varies from 85 per cent. for small wires to 90 per cent. for larger sizes. This gives us $\frac{3.00}{0.0419} \times 0.09 = 64$ turns per layer, or our 226-turn primary will require 4 layers, and the space taken up will be $4 \times 0.1116 = 0.4464$ ". Our coil diameter at the outside of the primary then is $1.812 + 0.446 = 2.258$ ". The usual tubing between primary and secondary is about 0.040"—0.045" thick, so our diameter at the inside of the secondary is:

tube	2.258"
1/2" for bow	0.090"
	0.031"
	2.379"

The secondary space is figured in like manner—

Wire diameter	0.0097"
Paper	0.0025"
+ 25 per cent.	0.0006"
	0.0128"
+ 10 per cent.	0.0013"
	0.0141"

Added diameter per layer	= 0.0282"
Turns per layer	= $\frac{3.00}{0.0097} \times 0.88 = 270$
Number layers required	= $\frac{2700}{270} = 10$ layers
Secondary space	= $10 \times 0.0282 = 0.282$

Our diameter at the outside of the secondary is then $2.379" + 0.282" = 2.661"$

A wrapper 0.025" thick is satisfactory between the secondary and 281 filament windings and between the various ter-

SIZE PRIMARY WIRE	PRI. TUBE THICKNESS	PAPER BETWEEN LAYERS	SIZE SECONDARY WIRE	PAPER BETWEEN LAYERS
16-18	0.080"	0.007"	28-30	0.0030
19-21	0.060"	0.005"	31-33	0.0025
22-24	0.040"	0.004"	34-37	0.0020
25-27	0.030"	0.003"		

Fig. 6

tiaries, and about 0.030" will be sufficient for an outside wrapper. We continue our computations—

Outside of secondary	2.661"
Wrapper 0.025" x 2	0.050"
	2.711"
281 fil. winding No. 21	0.030"
	2.741"
Wrapper	0.050"
	2.791"
250 fil. winding No. 18	0.042"
	2.833"
Wrapper	0.050"
227 fil. winding No. 15	0.059"
Doubled	2.942"
Outside wrapper	0.060"
	3.002"

Our coil will, therefore, be 3.002" or approximately 3" in diameter, and as we have a 3 1/2" window we can easily get the

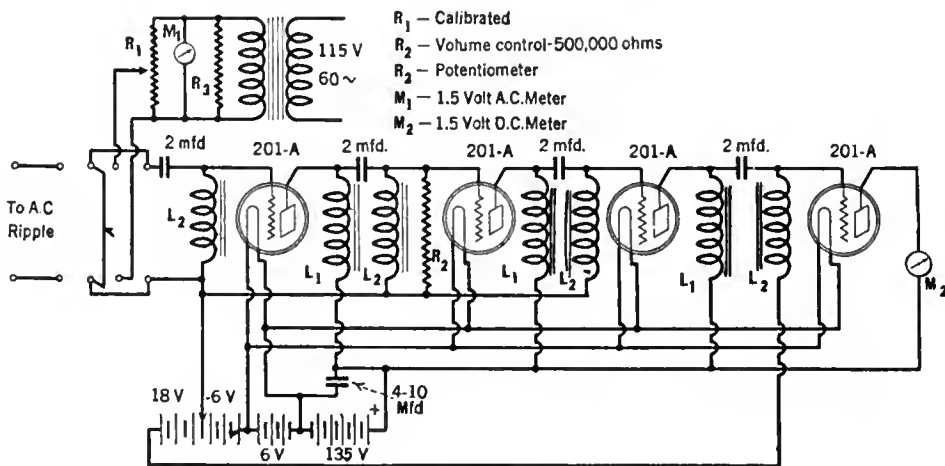

Fig. 7

coil in it, allowing for commercial variation. If the coil had turned out oversize it would have been necessary to use a larger stack of laminations, cutting down turns correspondingly.

We can tabulate our coil thus—

Core	1.750"
Outside of pri.	2.258"
Outside of sec.	2.661"
Outside of 281 fil.	2.741"
Outside of 250 fil.	2.833"
Outside of 227 fil.	2.942"
Outside diam.	3.002"

If it is necessary to design a choke coil, the same process serves to compute the space required, although the process is simplified considerably by having only one winding. Similarly it may be used in determining size of field coils, audio transformers, etc.

The Heat Run

Having designed our transformer and chosen a choke coil we must check our design by placing the apparatus on a heat run. This consists of setting the pack up under actual working conditions and let-

ting it run continuously for five or more hours, measuring the resistances of the various windings at the start and finish. The temperature rise of a winding may be computed from the following equation—

$$\Delta t = 234 \frac{(R_H - R_c)}{R_c} + \frac{T_c R_t}{R_c} - T_H$$

Where T_c is the room temperature at the start of the run, T_H the room temperature at the end, R_c the cold resistance of the winding, R_H its resistance at the end of the run, and Δt the temperature rise in degrees centigrade (all temperatures centigrade). It will be found that if the rise is not over 50 degrees centigrade the heating will not be excessive.

We are now ready to assemble our pack, properly dispose the component parts, and choose values of filter capacity. It is here, probably, that the hardest part of pack design enters, as, while it is fairly easy to evolve a good filter by brute force means, it is not as easy to get down to an economical minimum of capacity and parts and still have a satisfactory absence of hum.

In the measuring of a.c. ripple it is necessary to use a very sensitive indicating device which is capable of measuring potentials of a few millivolts and up to about a volt. This is best obtained by the use of a vacuum-tube voltmeter with an associated amplifier, such as is illustrated in Fig. 7. This employs a three-stage impedance-coupled amplifier feeding the customary vacuum-tube voltmeter. Im-

pedance coupling is advocated because resistance coupling requires more B battery potential for its operation. It would be advisable to use wet B batteries and to have as much plate by-pass condenser as possible, as is quite obvious when we consider that this amplifier must be practically flat from 25 to 120 cycles. The chokes L_1 should be as high in inductance as possible for the plate current they must carry, and chokes L_2 can be of the order of transformer secondaries.

The comparison method is used, the switch being connected so that the a.c. ripple is impressed on the amplifier, and the volume control and R_2 adjusted to give a good reading of M_2 . The switch is now thrown the other way and the attenuator adjusted to give the same reading of M_2 as before. Our a.c. ripple will then be the product of the attenuation ratio and the reading of M_1 . This gives us a convenient and sufficiently accurate means of measuring ripples from a few millivolts up to a volt.

The Hum Problem

We are now prepared to tackle our hum problem. Connect the pack to the set for which it is designed and connect the measurement set across the loud speaker. This gives us a visual indication of hum intensity and shows up small variations that the ear would not detect. Of course, experience will be necessary before the measurement of hum in millivolts can be correlated to the resulting

(Concluded on page 50)

LINEAR POWER DETECTION

By FREDERICK EMMONS TERMAN

Stanford University

TWO YEARS ago the typical radio set employed a grid-leak grid-condenser type of detector that was intended to operate with a radio-frequency input voltage of 0.1 volt or less. In contrast with this, the new receivers of the 1929-1930 season practically all use a power detector, in which the radio-frequency signal applied to the detector has a magnitude of at least several volts. In advertising the manufacturer makes this a big talking point. In some cases it is emphasized that a *linear* power detector is used. One may wonder whether this sudden change in detector practice is a real improvement, or whether it is another fad, such as the toroidal coils of several seasons ago, that is being used as a sales point, and will soon disappear.

The answer to these questions is clear and decisive. Compared with the weak-signal detector of the past, the power detector introduces less distortion, is more efficient, has a tendency to reduce static, and also increases the selectivity. Any one of these features would be very desirable, but when the change from weak-signal to power detection gives benefits in all of these ways, there is very little question as to what is the best practice.

Linear detectors and power detectors are very closely related in practice, since they usually go together. In the usual meaning of the term, "power" is used in connection with detection when the radio-frequency voltage applied to the detector is one or more volts, in contrast with a potential of 0.1 volt or less used with the weak-signal rectifier of the usual grid-leak grid-condenser type. *Linear* detection means that the detector output is proportional to the applied radio-frequency signal voltage. In the weak-signal detector the output is proportional to the *square* of the signal strength, so that the detector is proportionately more sensitive on the parts of the modulated signal when the signal voltage is at a maximum than when at a minimum. In contrast with this, the power detector as used in all of the present-day broadcast receivers has a characteristic that is approximately linear even though the manufacturers do not specifically mention this point.

The square-law characteristic of the

weak-signal detector introduces distortion frequencies which were not present in the original signal. These distortion frequencies form a larger and larger percentage of the audio-frequency output as the degree of modulation of the transmitted signal is increased. The present trend in the design of broadcasting stations is to use much higher degrees of modulation than were possible a few years ago, and all of the newer stations can modulate up to 100 per cent., in contrast with a maximum possible figure of not over 50 per cent. of a few years ago.

The distortion frequencies introduced by square-law action consist of second har-

Professor Terman brings to light an interesting and hitherto unannounced advantage of linear detection. This is its tendency to eliminate an undesired weak signal in favor of a strong desired signal; a tendency which is not shared by square-law detectors and one which increases the apparent selectivity of a receiver.

monics of the notes actually being transmitted and also all the possible sum and difference frequencies. Thus, if the sending station is simultaneously transmitting notes of 1000 and 1500 cycles, the output of the square-law detector, in addition to containing these desired frequencies, will also contain double-frequency components of 2000 and 3000 cycles and sum-and-difference frequencies of 2500 and 500 cycles. These distortion components may, under the most unfavorable conditions, be 25 per cent. as large as the desired components, making it apparent that weak-signal detection of signals that have a high degree of modulation will not give satisfactory results from the point of view of quality.

In contrast with this square-law action, a detector which has a linear characteristic introduces no frequencies in the audio-frequency output that were not present in the original signal. In order to have distortionless detection it is absolutely essential, therefore, that a linear characteristic be employed. The ordinary power detector of either the grid leak or C bias type has approximately such a characteristic and so gives substantially undistorted rectification.

Another advantage of power detection in regard to quality is that in detection of large signals the audio-frequency output is so much greater than with the weak-signal rectifier that it is possible to use one less stage of audio-frequency amplification, thus dispensing with one of the audio-frequency transformers and with the distortion which it introduces.

The efficiency with which the ordinary power detector rectifies the radio-frequency voltage is very much greater than in the case of the weak-signal rectifier. Thus, if a weak-signal detector with 0.02-volt input

is replaced by a grid-leak power detector having 0.5-volt input the audio-frequency output is increased not 25 times, but nearly 80 to 100 times. As a result of this increased efficiency with large signals, a moderate increase of radio-frequency amplification before detection is equivalent to a much larger amount of audio-frequency amplification after rectification. In the usual radio set, increasing the radio-frequency amplification about ten times, to bring the normal detector input from 0.05 volt up to 0.50 volt, will make it possible to drop out one stage of audio-frequency amplification (which amplifies about 25 times) without reducing the output of the power tube.

The performance of a typical detector for different input voltages is shown in Figs. 1 and 2. The audio-frequency output as a function of signal voltage applied to the detector is given in Fig. 1. For large signals this relation is obviously very nearly a straight line, while for small inputs the output follows a curved path. This transition from a square-law to linear characteristic as the signal is increased is typical of all detectors.

The efficiency of rectification for the case of Fig. 1 is shown in Fig. 2. This efficiency is expressed in terms of the ratio of actual audio-frequency output to the audio-frequency output that would be obtained from a perfect rectifier. The most important features to observe in Fig. 2 are the low efficiency with small signals, and the fact that the efficiency is relatively high and constant under conditions giving linear operation. It is also to be noted that grid-leak detection is much more efficient than plate detection when compared for the same signal. At the same time the C-biased power detector is always more efficient than the weak-signal grid-leak detector, and also has the very important advantage of a linear characteristic.

Detectors with a linear characteristic are much less susceptible to interference from static than are those with square-law characteristics. This can be illustrated very easily by a concrete example in which it is assumed that a static crash 10 times as strong as the signal is present. In the square-law detector this static impulse produces an output that is 100 times as strong as the signal, while with the linear

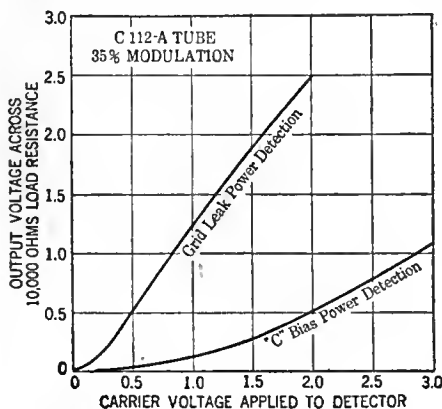

Fig. 1—Audio-frequency output of a detector as a function of the input voltage.

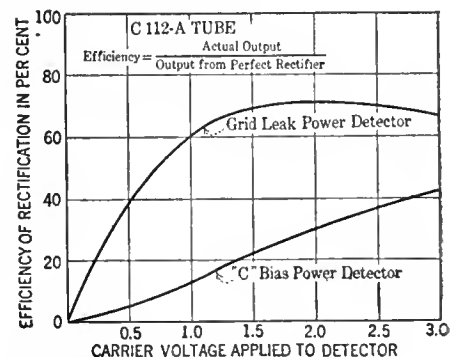

Fig. 2—Efficiency of rectification as a function of the input voltage.

detector, the straight line action operates in such a way as to make the static noise only 10 times the signal strength. It is obvious that the static will create less disturbance in the latter case.

A very important property possessed by the linear detector, and one which is not generally appreciated is that when two signals are simultaneously applied to a detector and the weaker of the two is an undesired signal, but yet is strong enough to be heard as an interfering background, the action of the linear detector is such as to suppress the weaker of the two signals, and to prevent it from being heard! This rather surprising result can be explained most readily with the aid of the diagrams in Fig. 3 in which A shows the desired signal, while B is the weaker interfering signal having a different frequency from the first, and C, which is A and B added together, represents the voltage actually applied to the detector input. With a straight-line detector the audio-frequency output is proportional to the envelope of the wave in C, resulting in the audio-frequency output shown at D. It is apparent that this output contains no contributions introduced by the weaker of the two signals other than the inaudible supersonic beat note between the two carriers. The total result is that with a straight-line detector the strong signal prevents the weaker superimposed signal of a different frequency from being detected.

[This will not be the case if the detector characteristic is other than linear. Then the weaker signal will be rectified and the rectification products will be heard even when the strong signal is present.—Editor.] This is, in effect, increasing the selectivity of the receiver, but has the great advantage over selectivity gained by tuned circuits in that there is no sideband trimming involved.

The full benefit of this increased selectivity is not realizable in practical receivers for several reasons. In the first place, no detector has a perfectly straight-line characteristic, and, unless the characteristic is absolutely straight, the weaker signal is not completely suppressed. Also, in order to obtain full suppression of the weaker signal it is necessary that the strong signal always be larger than the weaker one. If the strong signal is modulated 100 per cent, there are times when its amplitude goes down to zero, and at these moments, of course, there is no suppression, or rather, what is normally the weaker signal may momentarily suppress the normally stronger one. The net

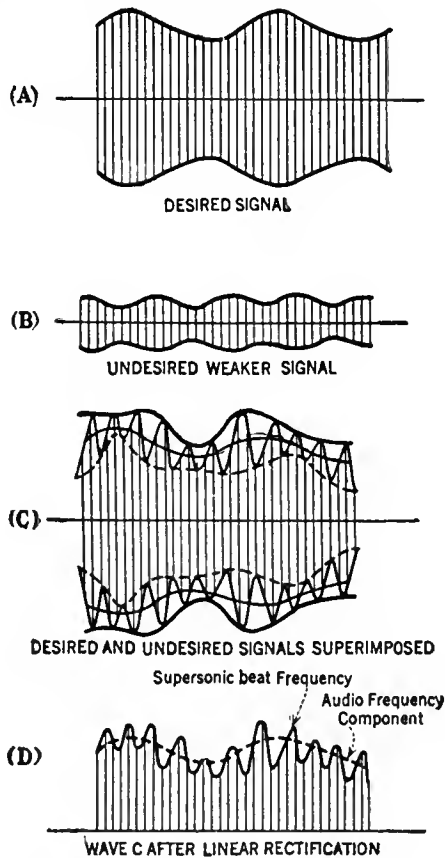

Fig. 3—Suppression of detection of weaker undesired signal by linear rectification.

result is that with the linear detector, as used in practical receivers, strong signals are able to reduce the efficiency with which weak but interfering signals are rectified

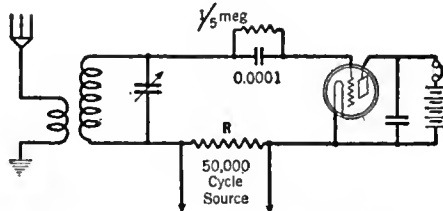

Fig. 4—Circuit for demonstrating how a strong signal can suppress detection of a weaker one when a linear detector is used.

to an extent that materially increases the apparent selectivity of the set, although complete suppression is not obtained.

The possibility of suppressing a weak signal by a strong signal of different frequency was tested with the aid of the circuit in Fig. 4, in which a grid-leak power detector was used. The test was made by tuning in a moderately weak broadcast signal when no 50,000-cycle current was flowing through the resistance R. With the music coming through satisfactorily as determined by listening in the head phones a 50,000 cycle voltage was superimposed upon the broadcast signal by running a current through the resistance. As soon as this was done the music practically disappeared. It was found that two or three volts across the resistance were enough to eliminate substantially all detection of the broadcast signal, although the detector was adjusted to take inputs several times this amount before overloading. It is not necessary to use 50,000 cycles for the suppressing frequency, and any frequency, other than one giving an audible beat note with the broadcast signal, would have given the same results. This little experiment shows that a strong signal is really able to suppress a weaker signal when the two are superimposed and applied to a linear detector.

This comparison of power and weak-signal detection shows that the former is superior in that it introduces less distortion, is a more efficient rectifier, gives less disturbance with strong static impulses, and results in an increase in the effective selectivity. The linear power detector is obviously here to stay, and the future will see it used more and more. It has even been suggested that some day the input to the loud speaker will be obtained by rectifying a very large radio-frequency signal of perhaps 100 volts, using a vacuum tube, or perhaps a copper-oxide element, without the use of any audio-frequency amplification.

Power detection requires more radio-frequency amplification than does the weak-signal detector, and not many years ago this was a real disadvantage. The screen-grid tube has altered the situation, however, by making it comparatively simple to obtain high amplification per stage without trouble from regeneration. Inasmuch as it is still necessary to use the same number of tuned circuits in screen-grid sets as before, in order to obtain the necessary selectivity, the additional radio-frequency is so easy to obtain as to be an advantage.

DESIGNING THE POWER-SUPPLY CIRCUIT

(Continued from page 48)

sound, and accurate limits set for acceptable hum, as this depends upon frequency, type of loud speaker, efficiency of loud speaker, and cabinet resonances. However, after a while the operator will be able to pass very accurately on the acceptability of any particular job.

To analyze the hum coming from our set and power pack we can short circuit various tubes, cutting out certain parts of the total hum. For instance, if we short circuit the primary of the last a.f. transformer all the hum we get is coming from the power tubes alone. If we put a very large by-pass condenser across the grid-bias resistor we can tell whether it is grid ripple or not, and, if it is not, then we can increase the capacity of C₂ (see Fig. 1). If this helps we know we have excessive plate ripple and either C₁ or C₂ or both must be increased to secure satisfactory filtering. However, if this does not help

then our hum is coming from the filament supply and may be due to unbalanced tubes, or unequal halves of the filament-supply winding. However, it will be found in the great majority of cases, especially when using push-pull, that the hum will be very low when the last a.f. primary is shorted.

To locate hum coming by induction from power transformers and choke coils we can remove various tubes and place resistors across the primary of the succeeding transformer. Thus, if we remove the detector tube and place 20,000 ohms across the primary of the first a.f. transformer, we can tell how much induction there is by rotating the transformer, and if it is serious we can locate the apparatus properly to minimize it. It is obvious that our first a.f. transformer will give more trouble from this source than the second due to higher succeeding amplification.

Having finally chosen our capacity

values it is only necessary to specify their working and break-down voltages. For instance, we found 613 volts necessary across C₁ at a 115-volt line. The highest line voltage we might encounter is about 130 volts, and, if no regulator were employed, this would result in an r.m.s. potential of almost 700 volts, or a peak of 980 volts. This, then, is going to be our maximum working voltage and C₁ should be specified for 1200 volts to have a sufficient margin of safety.

Of course, we must also check all our filament and plate voltages accurately to make sure our computations were correct.

We have now finished our power pack, have a job producing the required voltages, giving acceptably low hum, keeping within safe limits of heating and break-down, and costing as little as possible. Our job then, is finished, and we turn our pack over to the production department to do with as they will.

GILFILLAN MODEL 100 RADIO RECEIVER

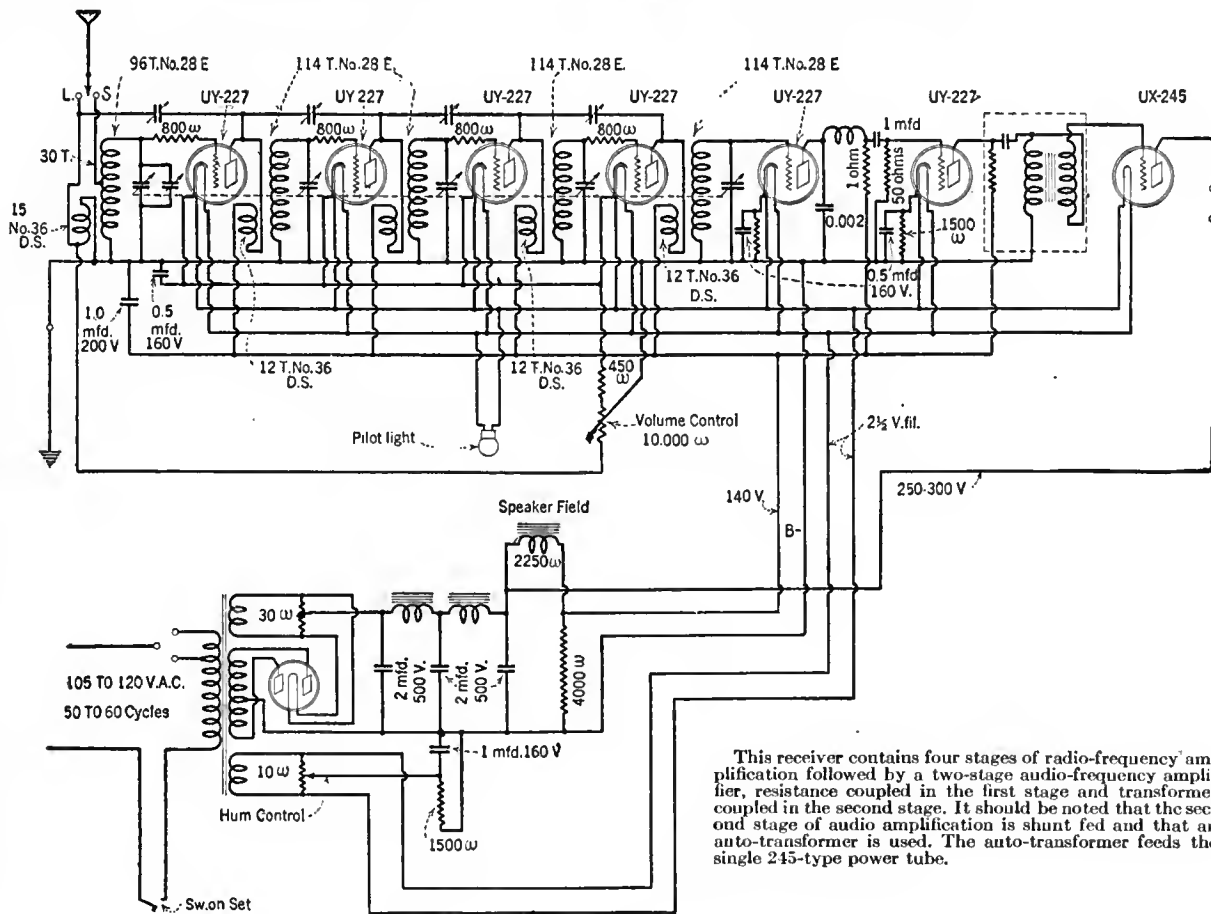

This receiver contains four stages of radio-frequency amplification followed by a two-stage audio-frequency amplifier, resistance coupled in the first stage and transformer coupled in the second stage. It should be noted that the second stage of audio amplification is shunt fed and that an auto-transformer is used. The auto-transformer feeds the single 245-type power tube.

THE KENNEDY RECEIVER CHASSIS NO. 10

This seven-tube receiver employs a three-stage radio-frequency amplifier of high sensitivity and uniform gain. All tuning condensers are ganged to a single control. The detector is followed by the conventional

two-stage transformer-coupled audio-frequency amplifier with two 245-type tubes in the output. The radio-phonograph switch connects the phonograph pick-up unit directly to the grid of the detector tube.

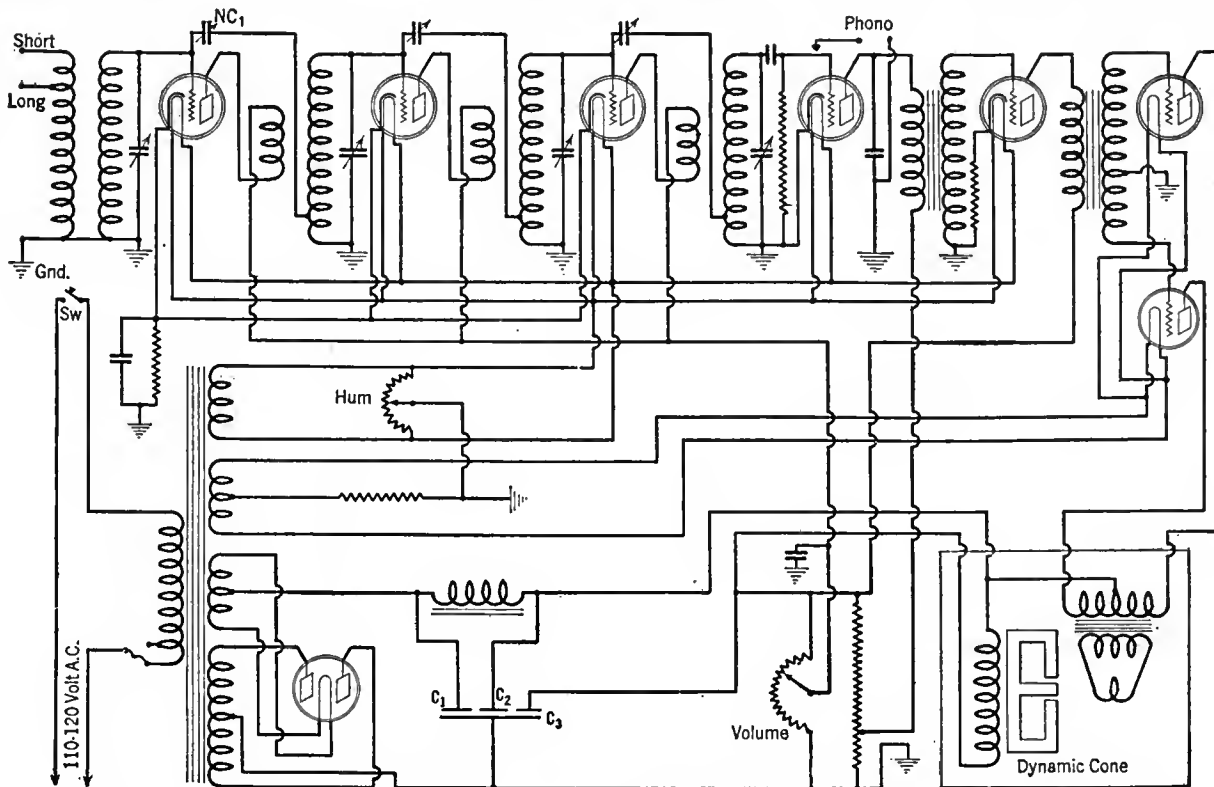

AN EFFICIENT RADIO SET DIAGNOSER

By HERBERT M. ISAACSON

Engineering Department, Colonial Radio Corporation

THE BENEFITS to be derived from the use of a set-tester or "diagnoser" have been so well rehearsed that they are familiar to every serviceman. A diagnoser facilitates rapid, systematic, and accurate testing of a receiver, since any deviation from the normal in either set or tubes gives a visual indication on the panel of the tester. Because each circuit of the receiver is checked individually, the faulty circuit is isolated quickly, and the trouble is run down to the defective piece of apparatus. To a large extent, then, it removes the guess work from servicing and enables the serviceman to make an accurate diagnosis of the fault in a minimum of time.

Important Features

The diagnoser described in this article embodies all of the features found in the best of manufactured test sets, and, in addition, it has several points of superiority which have been developed by the writer. The important features of the diagnoser are as follows:

1. *Portability:* The tester measures only 8 × 11 × 4 inches and weighs seven pounds.
2. *Ease of manipulation:* All readings are obtained by depressing push buttons. These buttons may be locked in a closed position when desired.
3. *Universality:* The tester is capable of checking any standard receiver or tube without requiring the connection of extra leads or external sources of power. (See Fig. 1.)
4. *Completeness:* The tester tells a complete story. It will measure filament, grid, plate, and screen-grid voltages and plate currents existing at the tube sockets of the set. Complete circuit continuity may be checked, with one exception—the grid circuit of a grid leak-condenser detector.

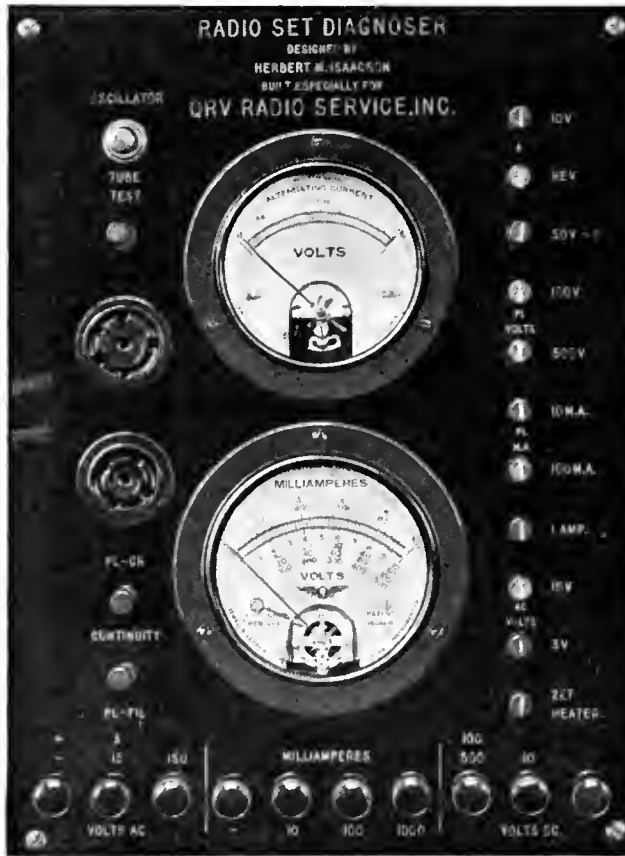

View of the diagnoser designed by the writer.

5. *Adaptability:* The various current and voltage ranges of the meters are available for external connection and the tester is designed so that special tests may be performed easily. For example, heater and line voltages may be measured and the polarity and charging rate of trickle chargers may be determined.
6. *Serviceability:* Simplicity of design in the mechanical features and the selection of quality materials in the construction insure serviceability.

7. *Foolproof:* Any or all of the buttons may be locked down simultaneously without damage to the diagnoser or the set under test.

8. *Versatility:* By use of the diagnoser, sets can be neutralized, overall sensitivity checked, effectiveness of pick-up systems tested, degree of shielding of loop-operated sets located in steel buildings investigated, position of break in concealed indoor antennas found, capacities of condensers and the value of resistors in megohms measured, and, in addition, the diagnoser incorporates a feature which has proved of great value—a modulated oscillator.

The Switching Mechanism

Since the diagnoser is built around the switching mechanism, this unit will be described first. As will be realized from a consideration of Fig. 2, the switching assembly may be made of ordinary knife switches. However, a cheaper and better method from all standpoints is to construct a push-button-operated switching mechanism. Such an assembly with all the switches necessary for the set-tester herein described can be built easily to take a space only 6 inches long, 2 inches wide, and less than 1 inch deep. A compact and symmetrical appearing piece of apparatus is the result.

The switch lever C is bent so that it exerts pressure against contact A. When the push button is pressed the contact at A is broken before contact can be made with point B. The circuit connections, of course, are made to contacts A and B and to the switch lever C. With contact A omitted we have a single-pole single-throw switch. By mounting two switches so that the one push button presses both levers at the same time a double-pole double-throw switch is obtained, with levers CC' always

Average Values of Plate Current Change for Standard Tube Types

Tube	E _g Appl'd	E _g * on Diag.	E _p	Normal I _p	Change in I _p	G _m	Limits	
							I _p	G _m
WD-11 and WD-12	0 3 4.5	.5 3.5 5	45 67.5 90	1.1 1.8 2.6	.17 1.2 2.15	340 360 430		
UV-199 and UX-199	0 4.5 4.5	1.5 6 6	45 67½ 90	1.5 1.1 2.4	.5 2.4 2.6	445 400 430		
UX-120	16.5 22.5	18 24	90 135	3.2 7	7.75 12	430 500	4.5	425
UV-201A and UX-201A	1.5 3 4.5 9	4 3.5 7 11.5	45 67½ 90 135	.9 1.7 2 2.5	1.7 3.25 5 6.85	430 570 725 760	1.3	550
UX-112A	4.5 9 10.5 13.5	7 11.5 13 13.5	90 135 157 180	4.8 5.8 7.9 7.8	10.5 18.4 14.2 28.6	1500 1600 1700 1700	4.5	1200

Tube	E _g Appl'd	E _g * on Diag.	E _p	Normal I _p	Change in I _p	G _m	Limits	
							I _p	G _m
UX-171A	16.5 27 33 40.5	19 29.5 33 40.5	90 135 157 180	11 16 18 20	22.8 24.1 46.2 60.7	1200 1360 1400 1500	11	1150
UX-226	6 12 16.5	6 12 16.5	90 135 180	3.7 3 3.8	5.2 9.8 14.4	870 820 870	3.5 At 13.5v PI and 9v C	800
UX-210	12 18 27 35	12 18 27 35	180 250 350 425	7 12 16 18.5	13.2 23.9 40.5 54.2	1100 1330 1500 1550	11	1325
UY-227	6 9 13.5	6 9 13.5	90 135 180	3 5 6	4.35 7.38 11.75	725 820 870	1.5	600

*Indicated C bias on Diagnoser is greater than applied by an amount equal to one half of filament voltage if d.c. is used on filament. Indicated and applied voltages are the same if a.c. is used.

making contact with points AA' except when the push button is depressed. By omitting contacts AA', a double-pole single-throw switch results.

It is often desirable to lock a button when making certain tests. As indicated in Fig. 2, by means of a groove cut in the panel and a pin in the button, a slight turn of the button when pressing it, keeps it down. Turning the button in the direction opposite to that used in locking it, allows the pin to sink into the groove as the spring of the switch lever brings the button up to its normal position. To indicate when the button is locked, a line is engraved on one end and parallel to the pin.

Since it is essential that the pin be in the exact center of the rod and at the proper distance from the ends, and that it must go through the rod at right angles to it, a hint on the best way to do it will not be amiss. In this connection the writer has found that best results can be obtained only by the use of a jig. Fig. 3 shows how to make one. The rod should fit snugly in the jig and it is inserted so that the engraved line is parallel to the pin hole. If care has been taken to make the distance from the pin hole to the end of the jig exactly the distance desired between the pin and the engraved end of the push button, all the buttons will come out identical and accurate.

As contact points $\frac{1}{2}$ -inch $\frac{3}{8}$ round-head brass machine screws are used. The ends of the screws should be sandpapered until they are bright. It has been found that the brass contacts give service for about a year before tarnish begins to interfere with their proper operation. The switch levers themselves can be cleaned by scratching with a needle through the contact screw holes. All the contacts of the set tester can be gone over in less than half an hour and the instrument will then be good for another year of service.

The D.C. Meter

The d.c. meter has a 1-mA. full-scale movement. This will allow the use of 1000 ohms per volt in the multiplier resistors; that is, when used as a voltmeter, the resistance for a particular scale is 1000 ohms multiplied by the highest voltage on that scale. For instance, the resistor for the 10-volt scale of the meter has a resistance of 10,000 ohms.

Meters marked with multi-range scales are obtainable from meter manufacturers or a 1-mA. scale may be used and the readings multiplied by the proper conversion factor.

Shunts are easily calibrated against another meter having the proper ranges. Be certain that the wire used for the shunt has sufficient carrying capacity for the current it is to handle. Since the shunts are in series they must each be capable of carrying the maximum current any tube might draw. There should be no trouble due to overloading the multiplier resis-

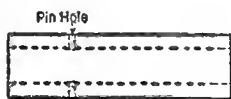

Fig. 3

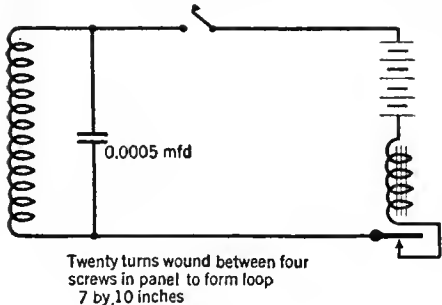

Fig. 4

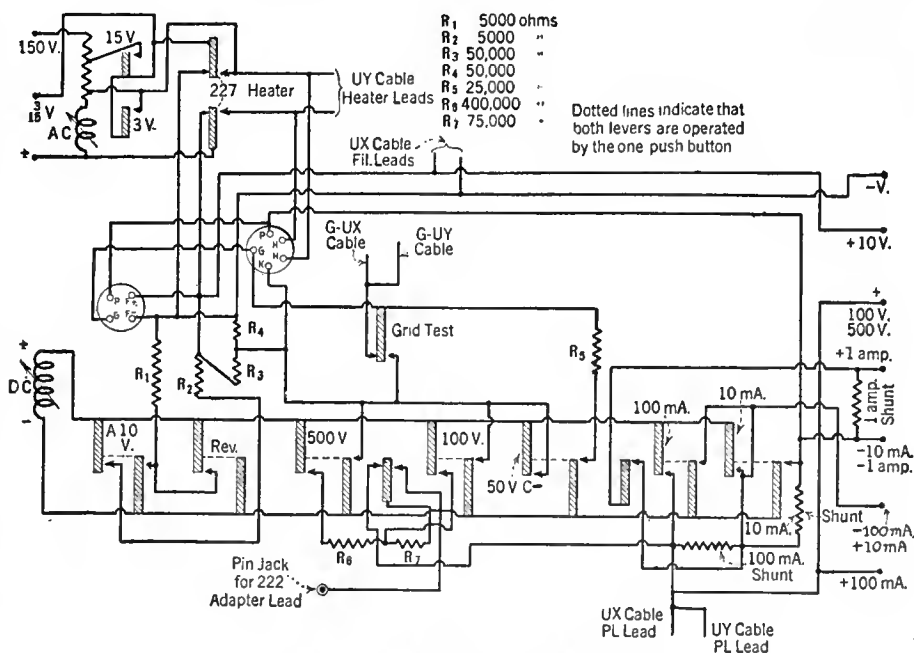

Fig. 1—Schematic of Diagnoser.

tors, since the maximum dissipation is 1 mA. at 500 volts or 0.5 watts. Practically all wire-wound resistors will dissipate at least this much wattage. If multipliers are made for the a.c. voltmeter the matter of

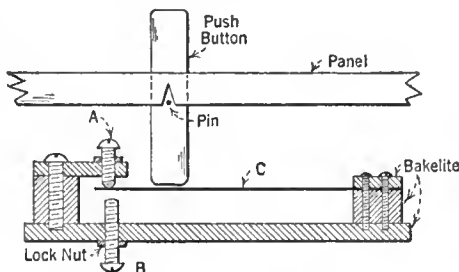

Fig. 2

Top View of Push Button showing Engraved Line

sufficient wattage capacity becomes very important since many a.c. movements draw as much as 300 mA. A 150-volt multiplier for such a movement would have a resistance slightly under 500 ohms (500 ohms minus the resistance of the movement) and would have to dissipate 45 watts at full-scale deflection.

A built-in oscillator is an absolutely necessary component of a set-tester. And it should be completely self contained. If it must be powered by the a.c. lines, its usefulness is largely curtailed. The oscillator used in this diagnoser consists of a tuned circuit, shock-excited by a buzzer. About 20 turns of magnet wire wound as shown in Fig. 4 and shunted by an 0.0005-mfd. condenser will give a wave of about 400 meters. The buzzer used should be of the high-resistance type. (Federal or Meseo). At 3 volts these buzzers draw less than 75 mA. and a couple of flashlight cells will, in ordinary service, last about a year. The test plugs can be made from tube bases. If you haven't access to a lathe, a wood-turner will make handles for them for twenty-five cents.

The picture shows the panel layout followed by the writer in the construction of his diagnoser.

Unless there is some manifestation of the trouble to indicate in just which circuit the fault exists, it is advisable to check through the receiver in the same order that

the signal follows— first radio-frequency stage, second radio-frequency stage . . . , detector, first and second audio stages. Insert the test plug (with an adapter if necessary) into the first socket of the set under test, and place the tube in the diagnoser socket. Pressing the button marked "A" (Fig. 1), will show the filament voltage at the socket. (Not the voltage of the A supply). Should the pointer move backwards, release this button and press the one marked "A rev." Alternating voltage is indicated when the "3V" or "15V" a.c. button is pressed. Some few sets using a.c. tubes have a resistor in series with the tube filaments. (The Garod EA and one of the Zenith models are the only ones the writer knows of.) In such a set, the voltage shown by the diagnoser's a.c. voltmeter will not be the actual voltage applied to the tube, but will be less because of the increased voltage drop across the filament series resistor occasioned by the added current of the voltmeter being passed through the resistor.

Grid circuit continuity is ascertained by pressing the "C" button. In a detector using grid-circuit rectification, the grid condenser must be shorted out to obtain a reading, since this condenser isolates the grid of the tube from the rest of the circuit, so far as direct currents are concerned.

The values of C bias have been arbitrarily taken with reference to the negative side of the filament. However, as may be seen from the circuit diagram, the grid return in the diagnoser is brought to a center-tapped resistor of 1000 ohms, across the filament. If the filament is supplied with a.c. there is no d.c. potential difference between the center tap and the filament terminals, and C bias may be read accurately with respect to it. If the filament is energized by d.c. this mid-tap, of the resistor is at a positive potential with reference to the negative end of the filament by an amount equal to one half of the filament voltage. In this way there is always a potential difference between the grid and the negative filament to indicate grid continuity, even when the set has no C battery. (There are still some antediluvian battery-operated relics, innocent of a C battery, in existence!) The actual C bias then, is the value indicated on the meter, less one half of the filament voltage, if d.c. is used on the filament. There is another effect, though, that tends

to offset this difference between the actual and the indicated C voltages, and because of it the indicated voltage may be taken as the actual voltage. It is the voltage drop in the secondary of the transformer (true only in a.f. transformers) due to the current drawn by the meter. It will depend, of course, on the resistance of the secondary, and the current drawn by the meter. As an instance, let us suppose a 112-type tube with 12 volts C bias and a transformer secondary of 10,000 ohms. Using the 50-volt C scale, at 12 volts the meter will draw about 0.25 mA. This current passing through the secondary resistance of 10,000 ohms causes a drop of 2.5 volts across it. The indicated C bias, therefore, is 2.5 volts less than the actual bias, which just offsets the 2.5 volts in excess of the actual voltage due to the mid-tapped resistor, and the indicated voltage then equals the actual voltage. Another point to watch out for when taking C readings in audio stages is the error caused by the volume control in the audio stage. The method usually employed is to connect a 200,000-ohm potentiometer across the transformer secondary and to tie the grid of the tube to the movable arm of the potentiometer. The meter current then must pass through the parallel path formed by the resistance between the center contact and one side of the potentiometer, and the resistance between the center and the other side of the potentiometer. In the case of a 200,000-ohm resistor, if the volume control happens to be half way on, the resistance in series with the meter would be 100,000 ohms, and the indicated C bias would be only one third of the actual bias. The remedy obviously is to turn the volume control all the way on.

Plate circuit continuity is indicated when either the "100V" or "500V" button is depressed. If the voltage is not known to be less than 100 volts it is best to press the "500V" button first to prevent overloading the meter. The voltage drop across transformer primaries, due both to the meter current and plate current of the tube must be taken into account to reconcile the value of indicated voltage with the voltage at the source. This difference is inconsequential except when determining the voltage of B batteries by a reading at an a.f. socket, or when the meter load assumes a considerable proportion of the total load, as in the case of a plate voltage reading on a detector tube. In this case if the plate voltage were supplied through a series resistor from a high-voltage source, the current drawn by the meter—which might be equal to half of what the tube uses—would cause a 50 per cent. increase in the drop across the series resistor.

The tube must be in the diagnoser socket when talking plate-voltage readings if the supply is from a power-supply unit.

Plate current is read by pressing the 10-mA. or the 100-mA. button. It is always best to press the 100-mA. button first, to be sure the current is not over 10 mA., and if it is not, to then press the 10-mA. button.

The heater voltage of a 227-type tube is obtained by inserting the 227 test plug in the set socket, the tube in the diagnoser socket, and pressing the "227 heater voltage" button. When taking a plate voltage reading on a 227, sufficient time must be allowed for the cathode to attain its working temperature.

From a consideration of the action of a vacuum tube as a voltage amplifier, it is

clear that the ratio of plate current change to the grid voltage change causing it is the best figure of merit of the tube. This relation is termed mutual conductance and is expressed in micromhos. Between two tubes of the same type, the one having the higher value of mutual conductance is the one better suited as a voltage amplifier. To measure the mutual conductance of a tube, with the diagnoser, divide the indicated value of grid voltage into the increase of value in plate current in milliamperes, when the "grid-test" button is pressed and multiply this figure by 1000. The result is the mutual conductance in micromhos. The table accompanying this article gives the average values of the change in plate current at the commonly used plate and grid voltages for most of the tubes encountered at present, together with their mutual conductance at these particular values of plate and grid voltage. Tubes of the same make may vary from 10 to 20 per cent. above or below the values given in this table. It should be remembered, however, that it is the change in plate current with change in grid voltage that is important. Sometimes two tubes of the same type will be encountered, one with a plate current swing from 1 mA. to 6 mA. amperes and the other with a swing from 5 mA. to 10mA. As voltage amplifiers one is as good as the other. The mutual conductance is the same for each. However, it would be preferable to use the one with the lower plate current in an audio stage since the audio transformer core would be worked at a lower flux density resulting in a higher value of permeability and hence increased primary impedance. The higher the primary impedance, the more uniform the voltage amplification.

A HIGH-RESISTANCE VOLTMETER SUBSTITUTE

By FREDERIC B. FULLER

IT IS WELL KNOWN that a low-resistance voltmeter cannot be used alone to measure the e.m.f. across a device which has considerable internal resistance. However, a milliammeter plus such a voltmeter can be used at considerable saving in cost over a high-resistance voltmeter.

The theory may seem a little complicated, but the method about to be described is simple and quick. There is a definite, though unknown, amount of resistance between the two points whose difference in potential is desired. Let this resistance be R, let the current through it be I, and the true voltage across it be E. Then by Ohm's Law $R = E/I$ expressed in ohms, volts, and amperes. Of these three unknown quantities, the current is determined most easily, by inserting a milliammeter in series with the load as shown in Fig. 1 (A) and noting its reading. Now connect the low-resistance voltmeter across both the milliammeter and the load, as shown in Fig. 1 (B). This will immediately cause a change in the reading of the milliammeter, as explained above. Let this new current reading be I' and let the reading of the voltmeter be E'. Here again, by Ohm's Law, $R = \frac{E'}{I'}$ (the resistance of the milliammeter is practically zero). Then, if we have $R = \frac{E}{I}$ we know that $\frac{E}{I} = \frac{E'}{I'}$ whence $E = E' \times \frac{I}{I'}$. In other words, the true voltage across the

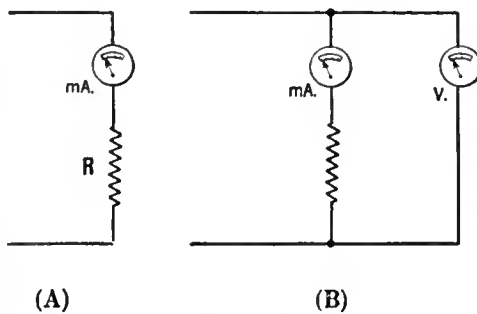

Fig. 1

load (that is, the voltage that will be there after the voltmeter has been removed) is the voltage indicated on the voltmeter reading before the voltmeter was applied to the ammeter reading after the voltmeter was applied.

One simple example will be given:
I = First ammeter reading = 0.030 amperes

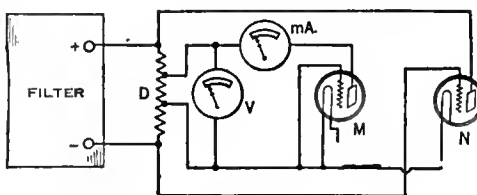

Fig. 2

I' = Second ammeter reading = 0.024 amperes
E' = Voltmeter reading = 36 volts
 $E = \text{True voltage} = \frac{0.030}{0.024} \times 36 = 45 \text{ volts}$

This method is absolutely accurate, regardless of how low the resistance of the voltmeter, provided, of course, that both ammeter and voltmeter are themselves calibrated accurately.

Incidentally, the resistance, R, of the load is learned by this method, for $R = \frac{E'}{I'}$, which in the above example, is $\frac{36}{0.024} = 1500$ ohms.

Measuring Plate Current

In measuring the voltage across a tube it makes a difference which side of the ammeter the voltmeter is connected to. In Fig. 2 a voltage divider, "D", is shown, and two tubes, M and N. If it is desired to learn the plate-to-filament voltage of tube M, for example, the "load" is the plate-to-filament resistance of tube M. The ammeter should be connected close to tube M, not close to the voltage divider, and then the voltmeter attached across both the ammeter and the tube, as shown. There will be a slight change in the plate resistance of the tube due to the slight change in its plate potential when the voltmeter is applied. But this is so small that it may be neglected entirely in most calculations.

Selectivity and Gain Characteristics

THE STEWART-WARNER SERIES 950

By A. C. MATTHEWS

Formerly Radio Engineer, Stewart-Warner Corporation

THE SET described in this article is known as the Stewart-Warner Series 950 Screen Grid. It utilizes eight tubes in all, including the rectifier. Three 224-type tubes are employed as radio-frequency amplifiers, two 227's, one as a plate-circuit detector and the other as an audio-frequency amplifier, and two 245's in push pull furnish approximately 3.2 watts of undistorted power output.

R. F. Circuit

From three stages of screen-grid r.f. amplification very high gain can be obtained. It was considered advisable, however, to sacrifice some of this gain by reducing the coupling in the r.f. transformers, thus gaining additional selectivity. With this thought in mind several methods of r.f. coupling were investigated, i.e., tuned plate, 1 to 1 ratio transformer, 1.25 to 1 ratio transformer, etc. Although each type gave considerable gain, they did not give uniform amplification over the entire tuning range of the set. It was not until the high-inductance primary in conjunction with a special coupling condenser was tried that it was possible to obtain uniform amplification throughout the broadcast band.

The r.f. transformer primary coil consists of 625 turns of 0.005" enameled,

cotton-covered copper wire wound on a $\frac{1}{2}$ " diameter wooden form. Its natural period, with the output capacitance of the 224-type tube shunted across it, is slightly below the lowest frequency of the broadcast band (it resonates at 490 kc.).

Theoretically, such an arrangement should give us a very stable r.f. amplifier, for, since the primaries are resonant below

tor and are adjusted before being assembled on the chassis. In general, the resonant point of the lumped primary determines the shape of the sensitivity curve at the low-frequency end, the capacity of the coupling condensers largely determines its shape at the high-frequency end, and the coupling between primary and secondary determines the height of the entire sensitivity curve. These effects as described are not strictly true, of course; for example, the setting of the coupling condensers affects slightly the sensitivity at the low-frequency end, and so on.

Considering the r.f. coil as a step-down transformer from plate to grid, it is readily seen that the impedance of the tuned circuit across the grid will be reflected back into the preceding plate circuit, thereby introducing an impedance comparable to the plate resistance of the tube. This, together with the adjusting of the capacitive coupling and the resonate point of the primaries made it possible to obtain an amplification of more than 35 per stage uniformly over the band. This was reduced slightly in order to provide a better factor of safety and to obtain a higher degree of selectivity.

Cross talk and local-station modulation of distant-station carriers is a serious matter with screen-grid circuits and neces-

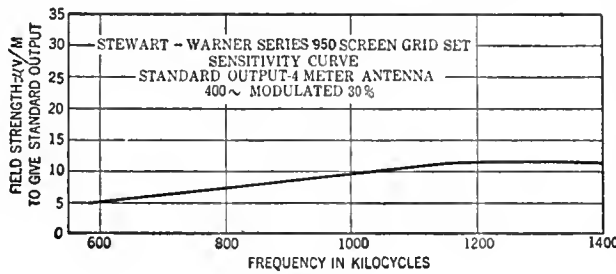

Fig. 2

the broadcast band, the plate circuits will have a capacitive load in them at any point in the band. However, the lack of perfect shielding makes it necessary to take the usual precautions in order to insure stable operation. Between the plates and control grids of succeeding 224-type tubes small capacities of about 10 mmfd. are connected. These capacitors are mounted on the side of the tuning capaci-

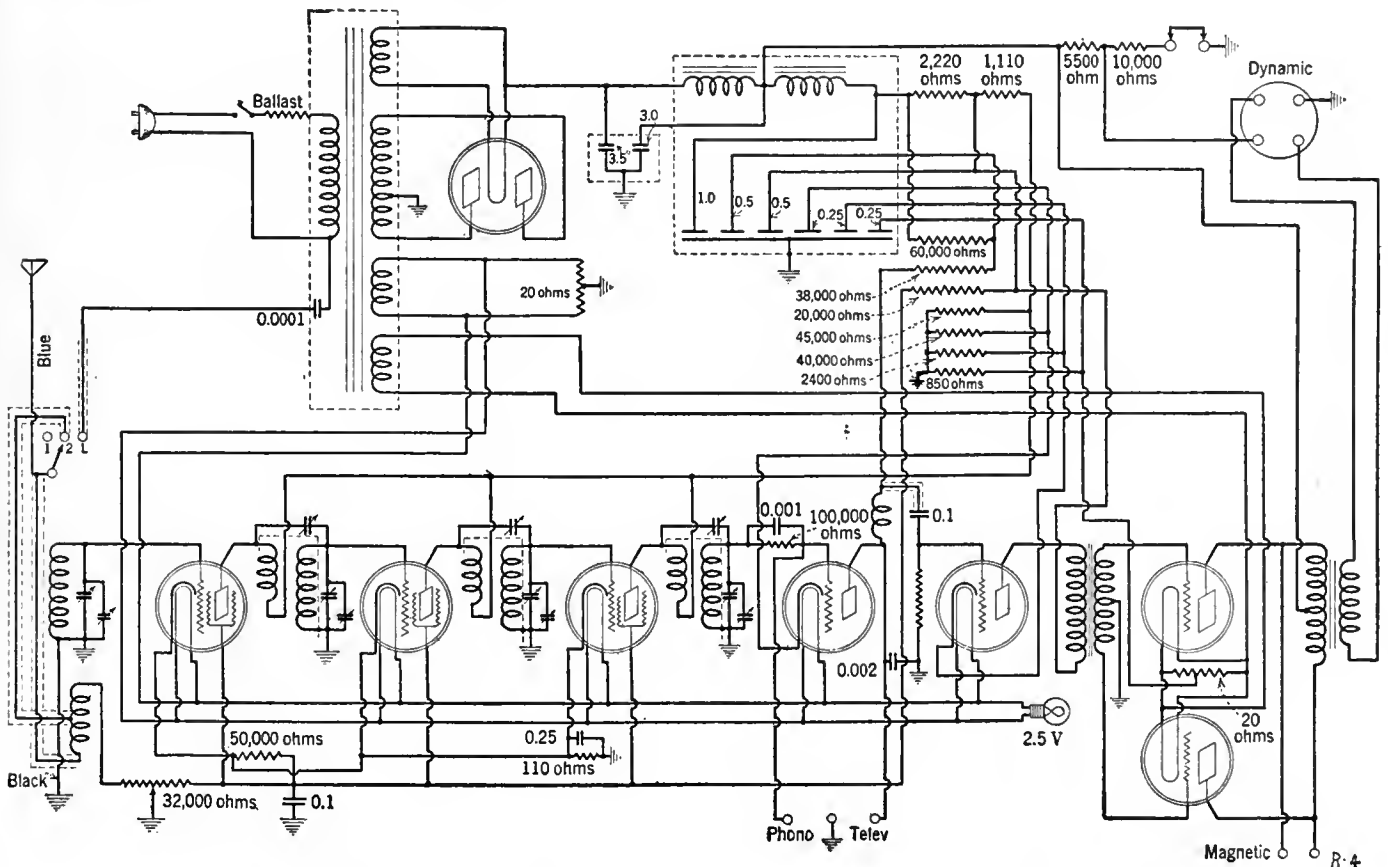

Fig. 1—Complete schematic diagram of the Stewart-Warner Series 950 Receiver.

sitates careful design of the volume-control circuit. In these receivers the volume control has a double function; first, it varies the screen-grid potential of the r.f. amplifier tubes, and second, it varies the signal input from the antenna to the set.

Detection

The large r.f. signal strength made available by the high gain in the r.f. amplifier makes possible the use of plate rectification without loss in overall sensitivity as compared with the usual grid-circuit rectifier used in conjunction with a lower gain r.f. amplifier. A 227-type tube is used as the detector. It is self biased to prevent overloading on strong signals. Such a detector will handle a very strong signal without any appreciable distortion due to overload. The resistor-capacitor combination in the detector circuit is of such a value that no grid rectification occurs and it is utilized merely to facilitate the connection of a pick-up unit to the detector grid circuit for reproducing phonograph records electrically.

Output Stage

Two 245-type power tubes connected in push pull are used in the output stage. These tubes are self biased and are operated at their maximum recommended voltages, making it possible to obtain

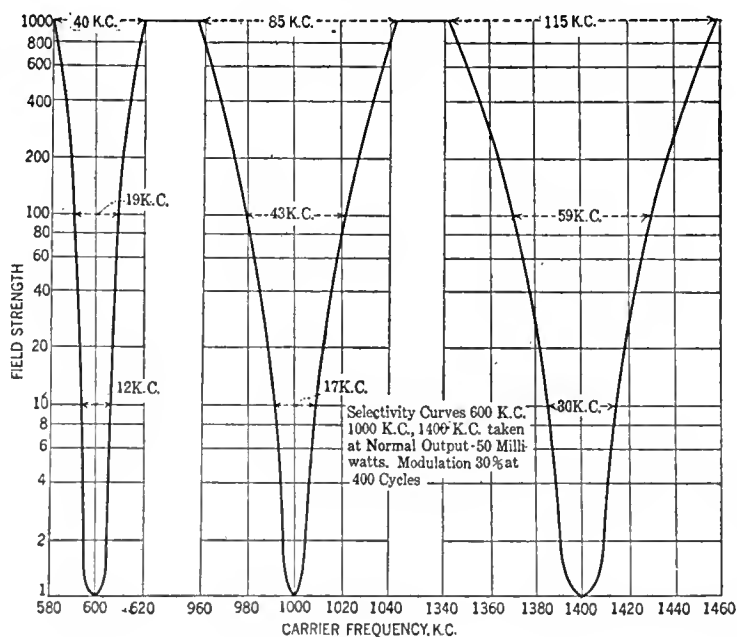

Fig. 3

approximately 3.2 watts of undistorted power output.

Either a magnetic or dynamic loud speaker may be used on this set. The magnetic loud speaker is connected by means of pup jacks in the rear of the chassis and the dynamic loud speaker is plugged in by means of a small tube base plug. This plug also connects the field coil of the dynamic to a source of rectified d.c. for magnetizing its excitation coil.

The sensitivity of this receiver shown

being received in order to have the same intensity in the loud speaker.

A circuit diagram giving the details of the circuit is shown in Fig. 1. Note the phonograph pick-up jacks, television connection, and means for connecting either a magnetic or dynamic loud speaker. Provision is also made for long, short, or light-socket antenna connections. An automatic voltage regulator is placed in series with the primary of the power transformer.

by Fig. 2, will be seen to be nearly a straight line, starting at 5 microvolts per meter at the low-frequency end of the band and increasing to 12 microvolts per meter at the high-frequency end.

Performance

As mentioned previously, the constants of the r.f. system were chosen to give good selectivity. The band width in kilocycles at 10, 100 and 1000 times normal input voltage to give a standard output of 50 milliwatts, measured across a representative load in the output circuit, is a measure of the ability of the receiver to separate one station from another. Fig. 3 gives such data taken at three different radio frequencies. A band width of 12 kc. at ten times normal input, as shown in the curve for 600 kc., means that a station 12 kc. from the station to which

one is listening must be ten times as strong as the station

being received in order to have the same intensity in the loud speaker.



BOOK REVIEWS



ENCYCLOPÉDIE DE LA RADIO, by Michel Adam. 356 pages, 1550 figures. E. Chiron, 40 Rue de Seine, Paris, 50 francs. 1923.

This illustrated dictionary of radio terms in the French should serve a useful purpose in many American radio libraries. The alphabetical arrangement is French, but in each case the German and English equivalents are given as well. The scope of the work is somewhat narrower than Sattelberg's *Dictionary of Technological Terms Used in Electrical Communication*, English-German, printed in Berlin by Julius Springer, since the Adam-Chiron effort is limited to T.S.F.—this cryptograph, it should be explained, originally stood for "télégraphie sans fils," or "telegraphy without wires," but has now been expanded to cover the whole field of radio. With a reading knowledge of French and German, the two works in combination should enable any normally trained radio engineer to steer his way through the bulk of the foreign literature of his art. The German volumes are getting a little old (1925) while the *Encyclopédie de la Radio* is up to date.

The descriptions of the various terms are succinct and in most cases exact and informing. Where a general term, such as "modulation," is involved, a more extensive discussion is presented. The size of the book, with its eight by ten inch pages, makes it possible to include a formidable amount of material.

As in every first edition of a work of this sort, there are a fair number of misprints. The number of serious errors is apparently small. Most of the blunders are amusing

but inconsequential. Edwin H. Armstrong, for instance, is consistently referred to as *Edwing* H. Armstrong. The English of *haubaner* is given as *anchor*, instead of *guy* or *stay* (in relation to masts) which is rather comical in view of the fact that *guy* comes from the Old French *gui*, a guide, whereas anchor is Anglo-Saxon. But these are trivialities and the book should interest all communication engineers whose horizon extends beyond the U. S. A.

RADIO OPERATING, QUESTIONS AND ANSWERS, by Arthur R. Nilson and J. L. Hornung. McGraw-Hill Book Co., New York. 367 pages, \$2.00. 1929.

This book by the two well-known radio educators, Messrs. Nilson and Hornung, is a second edition of their *Radio Questions and Answers*. It is intended as a companion volume to the same authors' *Practical Radio Telegraphy*, previously reviewed in these columns. *Radio Operating* is the immediate recourse of candidates about to take government license or civil service examinations, while *Practical Radio Telegraphy* is a more extended text for those who have time to study the technology of radio communication more fully.

The present volume starts with the standard request for a diagram of a complete commercial transmitting and receiving equipment, which has exhausted so many aspirants for operators' tickets in the inquisitorial chambers of the U. S. Radio Supervisors. Formerly, the transmitter shown was a spark set; now tubes are the thing. The various parts of the equipment, such as the overload circuit

breaker and the radio-frequency ammeter, are described individually.

Tube, arc, and spark transmitters are treated in turn. A typical question is, "What causes overheating of a transmitting tube?" The answer is that the plate voltage may be too high, or the circuit may not be oscillating properly, there may be a punctured plate blocking condenser, or improper bias, or the tube may be defective internally, etc. The trouble with these enumerations is that so many would-be operators memorize them as mere verbiage, with little practical idea of what the terms mean and what physical realities underlie them. That is why a theoretical text, and experience with the actual equipment, must accompany a volume like *Radio Operating* to make it really useful to the students. The authors recognize this in the bibliographies following each chapter.

Under "Receiving Apparatus" the venerable tiker is included as a means of receiving continuous waves, demonstrating that for radio equipment, at least, there is a life after the grave. The same chapter contains a brief treatment of modern radio compass technique.

Later chapters take up motor-generator sets used in radio transmission, the construction and care of storage batteries, the radio laws of the United States (brought up to date after the Washington convention of 1927), general theory, broadcasting, and amateur station operation. The appendices add useful information on examination conditions, abbreviations, wavelength allocations, etc. The book has an index.

Mathematical Discussion of the Fada Circuit

BAND-PASS FILTER DESIGN

By E. A. UEHLING

Engineering Department, F. A. D. Andrea, Inc.

SOME NOTES are given in this article on the design of the band selector used in the Fada receiver described by the writer in July, 1929, RADIO BROADCAST. In this receiver there is a signal selector of band-pass characteristics preceding the first radio-frequency amplifier tube.

In most filters already used the band of frequencies transmitted is narrow at long waves and very wide at short waves. The selectivity at the short wavelengths is usually not very good, even in the best receivers, because of the increased resistance of the radio-frequency circuits at the higher frequencies. It is obvious that if the width of the band transmitted by a band-pass filter increases as the wavelength decreases, the tendency toward broad tuning at the shorter wavelengths will be even more pronounced.

The Band-Pass Circuit

A simplified circuit of a band-pass filter having more desirable characteristics is shown in Fig. 1. It will be noted first of all that no magnetic coupling exists between the two circuits. There are two principal advantages of coupling these circuits as shown and these advantages will be described as follows: We are interested in the width of the transmission band which depends on the value of the quantity

$$\sqrt{\frac{R_2}{R_1} (M^2 - R_1 R_2)}$$

where R_1 and R_2 are the circuit resistances and M^2 is the absolute value of square of the coupling impedance. It will be seen that this coupling impedance should vary as the product $R_1 R_2$ varies with frequency, so that the quantity $(M^2 - R_1 R_2)$ is as nearly constant with frequency as it can be made. When the coupling between the circuits is magnetic the variation of the mutual reactance can be expressed as:

$$\frac{d(\omega L)}{d\omega} = L$$

If the coupling between the circuits is capacitive, the variation of the mutual reactance with frequency can be expressed as:

$$d\left(-\frac{1}{\omega C}\right) = \frac{1}{\omega^2 C}$$

Suppose we decide on 4 per cent. coupling as the value which gives the desired width of band at the longest wavelengths. With 230-microhenry tuning coils the mutual inductance will then have to be 9.6 microhenries and the variation of the mutual reactance with frequency, as expressed by the first formula, will be 9.6×10^{-6} . Now, if the coupling between the circuits is capacitive and a coupling of 4 per cent. is again chosen, the coupling capacity will be about 10,000 micromicrofarads, and at 550 meters the variation of reactance with frequency, as determined by the second of the two formulas, will be 10×10^{-6} . For either type of coupling the variation of reactance with frequency at 550 meters when the coupling percentage is adjusted for the same width of band is the same.

But in the case of magnetic coupling this variation is constant regardless of frequency, and in the case of the capacity coupling the variation in reactance with change in frequency decreases as the frequency increases. Thus we find at 200 meters the variation of capacitive reactance with frequency is equal to only 1×10^{-6} as compared with 10×10^{-6} at the same frequency for magnetic coupling. So in the broadcast range capacity coupling gives a more nearly uniform width of band than magnetic coupling, provided the width of the band is made the same for both types of coupling at 550 meters. That is, the actual arithmetic variation in band width is less for capacity coupling than for inductive coupling.

The second of the two principal advantages of this type of band-pass filter is that whatever variation in band width there is, it is in the most desirable direction as already stated. As the receiver tuning dial is turned to the shorter wavelengths,

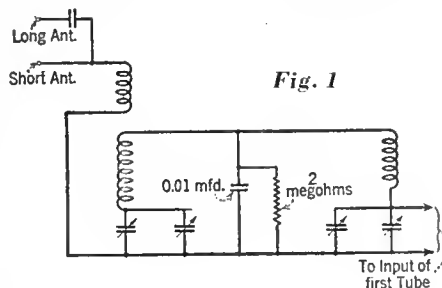

the coupling percentage is reduced constantly. This reduction in percentage of coupling is slightly more than is required to give constant width of band with the result that there is a slight decrease in band width at the lower wavelengths.

The use of a band-pass filter is not without some loss in voltage amplification as compared with other methods of signal selection. There is a voltage gain in this band-pass filter of about 2 at 550 kilocycles and about 4 or 5 at 1500 kilocycles. A comparison is given below of the voltage amplification obtained with the ordinary tuned antenna circuit and the circuit as used in this receiver will be shown.

The ratio of the voltage E_3 impressed on the grid of the first amplifier tube to the voltage E_1 impressed in the antenna is

$$\frac{E_3}{E_1} = \frac{m_1 m_2 \omega L}{Z_1'' Z_2' Z_3}$$

where (referring to Fig. 1) m_1 is the mutual impedance between the first two circuits, m_2 the mutual impedance between the last two circuits, L the inductance of the tuning coils in the band-pass filter, and Z_1'' , Z_2' , and Z_3 the impedance of the three circuits respectively as influenced by the reaction of the following circuits.

The ordinary antenna circuit differs from the circuit of Fig. 1 only in the absence of the third circuit. In this case the ratio of the voltage E_2 impressed on the grid of the first amplifier tube to the voltage E_1 impressed in the antenna is

$$\frac{E_2}{E_1} = \frac{m_1 \omega L}{Z_1' Z_2'}$$

where m_1 and L are the same quantities as before, and Z_1' and Z_2' are the impedances of the two circuits which are in general of different value than Z_1'' and Z_2' given above.

But we are interested in the ratio $\frac{E_3}{E_2}$, the ratio of the voltage impressed on the grid when the band-pass filter is used to that impressed on the grid when the ordinary antenna circuit is used. We get this ratio by dividing one equation by the other.

$$\frac{E_3}{E_2} = \frac{m_1 m_2 \omega L}{Z_1'' Z_2' Z_3} \frac{Z_1' Z_2'}{m_1 \omega L} = m_2 \frac{Z_1' Z_2'}{Z_1'' Z_2' Z_3}$$

The resonant frequency of the antenna circuit is so far above the highest frequency of the broadcast band that its reactance to broadcast frequencies is very high, and therefore Z_1 , the impedance of the antenna circuit, is very high compared with the impedance of the other circuits. Since Z_1 is very large, its coupling to the following circuits changes its value very little. Therefore,

$$Z_1 = Z_1'' = Z_1' \text{ approximately}$$

then

$$\frac{E_3}{E_2} = m_2 \frac{Z_2}{Z_2' Z_3}$$

Now the value of Z_3 is

$$\begin{aligned} Z_3 &= \sqrt{R_3^2 + X_3^2} \\ &= \sqrt{R_3^2 + \frac{R_3}{R_2} (M^2 - R_2 R_3)} \\ &= \sqrt{R_3^2 + \frac{R_3 m_2^2}{R_2} - R_3^2} \\ &= m_2 \sqrt{\frac{R_3}{R_2}} = m_2 \end{aligned}$$

Substituting this value of Z_3 in the equation above

$$\frac{E_3}{E_2} = m_2 \frac{Z_2}{Z_2'} \frac{1}{m_2} = \frac{Z_2}{Z_2'}$$

The value of Z_2' is

$$\begin{aligned} Z_2' &= \sqrt{R_2^2 + X_2'^2} \\ &= \sqrt{\left(R_2 + \frac{m_2^2}{Z_3^2} R_3\right)^2 + \left(X_2 - \frac{m_2^2}{Z_3^2} X_3\right)^2} \\ &= \left(R_2 + \frac{m_2^2}{Z_3^2} R_3\right) \\ &= R_2 + \frac{Z_2 Z_3}{Z_3^2} R_3 \\ &= R_2 + \frac{Z_2}{Z_3} R_3 \\ &= 2 R_2 \end{aligned}$$

then

$$\frac{E_3}{E_2} = \frac{Z_2}{2 R_2}$$

But Z_2 is the impedance of circuit II with circuit III removed, then

$$\begin{aligned} X_2 &= 0 \\ Z_2 &= R_2 \end{aligned}$$

hence

$$\frac{E_3}{E_2} = \frac{1}{2}$$

No. 304

RADIO BROADCAST Laboratory Information Sheet November, 1929

Distributed Capacity Measurements

THE method commonly used in laboratories to determine the distributed capacity of a coil is to tune it to various wavelengths by means of a condenser and then plot a curve of wavelength squared against the capacity of the tuning condenser. The curve will be a straight line but will not pass through zero because of the distributed capacity of the coil. If the curve is extended so that it intercepts the line corresponding to zero wavelength, the intercept will give the distributed capacity of the coil. The method is simple and quite accurate provided the individual measurements are carefully made. If, however, there are slight discrepancies in the various measurements it is necessary to estimate as accurately as possible the correct position for the curve.

There is another method of graphically determining the distributed capacity which is not generally used but which is sometimes more accurate than the one described. This second method is illustrated on "Laboratory Sheet," No. 305.

The general method of procedure is similar. The coil to be measured is connected across known capacities and the resonant wave-

length is determined. Some sample data is given below:

WAVELENGTH	CAPACITY TO TUNE TO RESONANCE-MMFD.
300	315
247	200
134	0

The next step is to lay out a curve sheet as shown on "Laboratory Sheet" No. 305. The left-hand axis is wavelength squared and the right-hand axis is the tuning capacity in micromicrofarads. Straight lines are now drawn being the various values of tuning capacity and the corresponding values of wavelength squared.

If all the measurements were perfect, these various straight lines would intersect at a common point but because of slight inaccuracies they do not. As a result there is formed at the center a small polygon. The center of this polygon must now be estimated and between the center and the point corresponding to zero wavelength a straight line is drawn. This line will intersect the capacity axis at the point corresponding to the distributed capacity of the coil. This latter line is shown dotted on the curve.

THE ROCHESTER I. R. E. DISTRICT CONVENTION

The following papers are scheduled to be given at the Eastern Great Lakes District Convention of the Institute of Radio Engineers to be held at Rochester on November 18 and 19: "Considerations in Screen-Grid Receiver Design" by W. A. MacDonald of the Hazeltine Corporation; "What Executives Expect of Engineers" by I. G. Maloff of the Valley Appliances Corporation; "Ultra High Frequency Transmission and Reception" by A. Hoyt Taylor of the Naval Research Laboratory; "A Broadcast Receiver for Special Purposes" by Paul O. Farnham of the Radio Frequency Laboratories; "Standardization in the Radio Vacuum Tube Field" by W. C. White of the General Electric Research Laboratory; "The Engineer in the Radio Industry" by H. B. Richmond of the General Radio Company and president of the Radio Manufacturers' Association.

Those attending the convention will be taken on inspection trips to Stromberg-Carlson plant, Kodak Park, and the Valley Appliance Corp.

The Rochester, Buffalo-Niagara, Cleveland, and Toronto Sections of the Institute are sponsoring the Convention, while the entire membership of the Institute will take part in its activities.

SELLING RADIO—THE BIGGEST SHOW ON EARTH

(Concluded on page 23)

But if you have made yourself an expert in your complete knowledge of broadcasting you are right on your customer's own street. You are a human being, therefore, you like to tell what you know. You know electricity and mechanics.

Make yourself a student of the drama of radio, its comedies, its utilities, its music, and its bally-hoo—all the elements which make it a big show. Get full of that kind of knowledge. Inevitably, as a human being, you will want to talk it, to tell what you know. Then conversationally you find yourself on the customer's own street and your native sales ability gets a fifty per cent. better chance to do its work.

You may even learn some things about broadcasting which the broadcasting stations themselves don't get, because your contact with the broadcasting audience becomes more intimate and more outspoken.

The radio business to-day is in the stage where both broadcasting and the receiving set trade do pretty well with the large numbers of people who really know they want to buy.

Suppose the motor car business were on that same basis. I venture to say that the total number of cars in use in the country might possibly be equal to what this year's sales will be, might be less.

Automobile makers, oil producers, retailers, highway builders, local boards of trade, state governments, all the resorts, merchants of all sorts, real estate people, all these and others are boosting the retail sale of automobiles for all they are worth, more cars, better cars, two to a family, then, three.

No, it is not quite a parallel case. I've tried to admit it before you said it. But the opportunity of profitable coöperation is in radio to similar degree, and for lack of that coöperation, radio is in some danger of slipping into a we-all-have-it and a take-it-for-granted condition long before its novelty, its romance, its daily gift of pleasure have been appreciated fully. The romance of radio and the friendly gossip of radio are still very salable.

No. 305

RADIO BROADCAST Laboratory Information Sheet November, 1929

Distributed Capacity Measurements

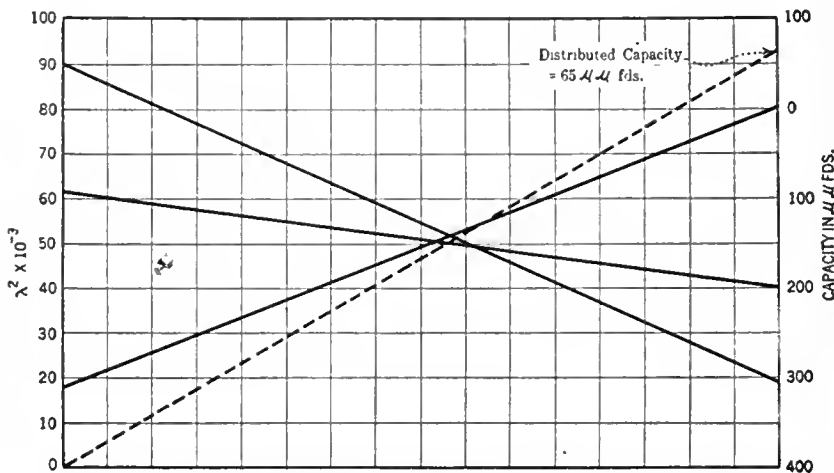

No. 306

RADIO BROADCAST Laboratory Information Sheet November, 1929

Advantages of Automatic Volume Control

THE use of automatic volume controls in receivers has certain definite advantages. The most obvious advantage is, of course, that such a control definitely determines the output of the receiver and maintains this output constant over wide variations in field intensity. Ordinarily as we tune from one local station to another the volume varies considerably, depending upon the field strength obtained from the station, but in a set equipped with an automatic volume control, all stations will give approximately the same volume.

The second advantage of an automatic volume control is that it helps to some extent to reduce the effects of fading, since, as the signal begins to fade, the sensitivity of the set automatically begins to increase and in this way partially compensates the fading.

A third advantage of this control system, is that by its use it is possible to apply an input to the detector tube of a definite value of r.f. voltage. The set may be so designed that with this value of voltage applied to the detector, the distortion produced in the detector circuit will

be a minimum. The distortion ordinarily produced in detector circuits is a function of input voltage. It is high for small values of input voltage and also for very large values of input voltage. At some medium values determined by the operating voltages of the detector tube, the distortion will be a minimum and it is of course advisable to operate the detector tube always under the conditions for minimum distortion.

These three advantages are responsible for the greatly increased use of automatic volume control systems and it is probable that in the future their use will become quite general.

The automatic volume control tube generally works on the output of the r.f. amplifier and it automatically functions to control the output of the r.f. amplifier by varying its sensitivity. When the field strength is very high, the volume control tube causes a large reduction in the sensitivity of the amplifier and when the field strength is very low the tube functions to maintain the radio frequency amplifier at maximum sensitivity.

SM

"Can't Beat the S-M 720?" Just Try this All-A. C. 722--And at \$74.75!

Have you heard the whisperings among the fans this fall—how Silver Marshall has brought out an all-electric custom receiver design which sells, completely wired at the factory, for only \$74.75 net—and yet which combines perfect convenience of operation with such extreme performance as has seldom been seen in the most complicated sets? Three screen-grid tubes, with band selector tuning—four tuned circuits in all—with screen-grid power detection—these, built up to the highest S-M standard of engineering, mean, of course, distance range right up among the top notchers. And if you think for one moment that selectivity has been sacrificed to full single-dial control—one test of a 722 on the most powerful local in your town will give you an entirely new conception of what S-M precision in coil manufacture can accomplish!

All-A. C. Operation

These receivers are absolutely all electric—even the 735 short-wave set, the first of its kind ever offered on the market. Power supplies are built into the receivers—not separate. (Power supply for the 712 is built into the 677 Amplifier.) The full advantages of the new a.c. screen-grid tubes are secured. The characteristic superior S-M tone quality, distance-range, and selectivity are in these receivers as never before, due not alone to band-selector tuning but also to still greater refinements of design and accuracy of manufacture.

Startling in perfection of tone quality, the 677 Clough-system Amplifier (right) is ideal either for powerful record amplification, or with the 712. Tubes required: 1—'27, 2—'45, 1—'80. \$58.50, less tubes. Component parts total \$43.40 net.

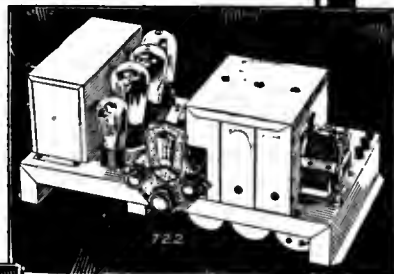

(Above)—three screen-grid tubes (including detector), band-filter, 245 push-pull stage—these help make the 722 the outstanding buy of the year at \$74.75 net, completely wired, less tubes and cabinet. Component parts total \$52.90. Tubes required: 3—'24, 1—'27, 2—'45, 1—'80.

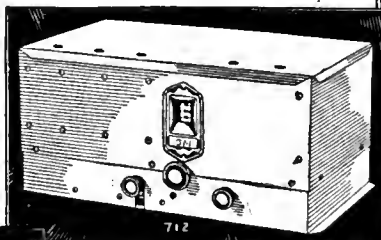

The New "Boss of the Air"—S-M 712

(Above)—A worthy successor to the famous Sargent-Rayment 710 of last season is the splendid new 712 tuner. Even if you have experienced the uncanny 10-kc. sharpness of the famous 5-vernier Sargent-Rayment—a new thrill comes with the 712. Here again are the five tuned circuits—two of them now joined in an ultra-modern band filter—and again the perfect shielding and the special shielded coils, whose tremendous accuracy makes possible the straight single dial tuning of the 712—without verniers, yet with performance far beyond competition regardless of price. Feeds perfectly into any audio amplifier; the S-M 677 is ideal, furnishing also all necessary ABC power. Tubes required: 3—'24, 1—'27. Price, only \$64.90, less tubes, in shielding cabinet. Component parts total \$40.90. Ideally suited for rack panel installations.

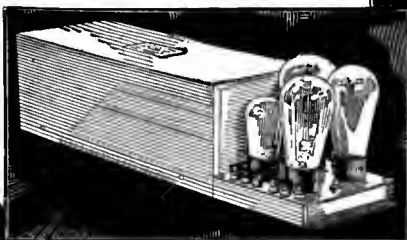

735 Short-Wave Receiver

(Left)—a screen-grid r. f. stage, new plug-in coils covering the bands from 17 to 204 meters, regenerative detector, typical S-M audio amplifier all help to make this first a. c. short-wave set first also in performance. Price, wired complete with built-in power unit, less cabinet and tubes, only \$64.90. Component parts total \$44.90. Tubes required: 1—'24, 2—'27, 2—'45, 1—'80. Two extra coils, 131P and 131Q, cover the broadcast band at an extra cost of \$1.65.

Adapted for battery use (735DC) price, \$44.80, less cabinet and tubes. Component parts total \$26.80. Tubes required: 1—'22, 4—'12A.

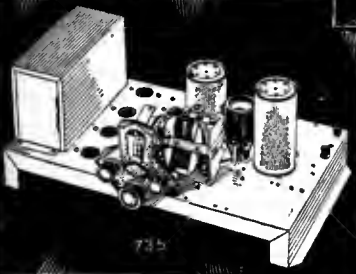

New!—

S-M 233U Universal Output Transformer

With a characteristic curve flat (to within 1.7 DB.) from 30 to 10000 cycles, this transformer has the further advantage of extreme flexibility. Three windings, with a total of 12 lugs, enable it to be used to match almost any impedances. As an output transformer it will work out of '71, '45 or '50 tubes singly or in push-pull. It will work into 12 different impedances from 9 to 200 ohms to feed directly into the voice coils of 1, 2, 3, 4 or 8 dynamic speakers. It will also match with 1000, 2000, 4000 or 8000 ohm circuits; may be used as a line output transformer as well. Open mounted, size: 3" long, 3 3/4" high, 3 3/4" wide. Price, \$9.00.

The RADIOBUILDER for October contains a full description of the 712 Tuner; 677 amplifier, and the new 233 Output Transformer, as well as an interesting article on Television Amplification. If you haven't seen it—use the coupon.

If you build professionally—write us about the authorized S-M Service Station franchise—it pays!

SILVER-MARSHALL, Inc.

6403 West 65th St., Chicago, U. S. A.

Beautiful Cabinets

The handsome new 707 table model shielding cabinet, finished in rich crystalline brown and gold, suitable for 722, 735, or 735DC, is only \$7.75. Special arrangements have been made whereby these receivers may be housed in magnificent consoles especially adapted to them. Be sure to send for the new Fall S-M General Parts Catalog, for details of these cabinets.

Silver-Marshall, Inc.
6403 West 65th Street, Chicago, U. S. A.

....Please send me, free, the new Fall S-M Catalog; also sample copy of The Radiobuilder.

For enclosed,in stamps, send me the following:

.... 50c Next 12 issues of The Radiobuilder
.... \$1.00 Next 25 issues of The Radiobuilder

S-M DATA SHEETS as follows, at 2c each:

- No. 3. 730, 731, 732 Short-Wave Sets
- No. 4. 255, 256, etc., Audio Transformers
- No. 5. 720 Screen Grid Six Receiver
- No. 6. 740 "Coast-to-Coast" Screen Grid Four
- No. 7. 675ABC High-Voltage Power Supply
- No. 8. 710 Sargent-Rayment Seven
- No. 9. 678ED Phonograph-Radio Amplifier
- No. 12. 669 Power Unit (for 720AC)
- No. 14. 722 Band-Selector Seven
- No. 15. 735 Round-the-World Six
- No. 16. 712 Tuner (Development from the Sargent-Rayment)
- No. 17. 677 Power Amplifier for use with 712

Name

Address

SERVICE—DO YOU OR YOUR CUSTOMERS PAY?

(Continued from Page 19)

of service. For example, it has probably not even occurred to most dealers that the portion of the store space devoted to service—shop, service desk space, and space required for storage of parts, accessories, and antenna equipment used by the service department—is space which would be devoted to some other purpose if there were no service department, or else a smaller store would be used. Therefore, the cost of that space (rent, or taxes and upkeep) should be charged against the service department instead of against general overhead. All of the stationery used by the service department should be charged against that department, and a separate telephone, or telephones, should be installed so that, insofar as possible, all service calls can be charged to service overhead instead of the common practice of making them a general overhead expense.

In short, a complete set of books should be maintained for, and by, the service department, and the expense accounts of that department should be as carefully subdivided as those of the sales department. The dealer should know, at the end of each month, and at the end of each year, the separate cost of labor, antenna equipment, apparatus, batteries, and tubes sold by the service department; the gross income from each of those items; the gross profit on each item; the percentage of profit on each item; and the totals of all those accounts grouped together. If the service department is not large enough to keep one bookkeeper busy, or one service executive busy, then whatever portion of the time of an individual is devoted to the service department should be so charged. Otherwise, the sales department would be carrying an item of office overhead which rightfully belongs to service.

Free Service

There is just one service item which may be properly charged to sales expense if the dealer desires to do so. That is the cost of performing free service within the limited guarantee period, and the cost of free installation if the dealer believes he

cannot break away from that harmful and unnecessary practice. It is fairly common practice in the automotive industry to charge the guaranteed free service to sales, and some successful radio dealers believe it to be good practice. The author does not agree with that view, however, simply because it has been proved by several dealers that the service department itself can carry that expense and still break even or make a profit. That is to say, it can carry the expense of the free service when permitted by the sales department to make a reasonable profit on the installation. If free installations are indulged in, the sales department, and not the service department, should most certainly be the one penalized. Any free service performed after the guarantee period, as return calls resulting from improper service, should, of course, be charged to the service department. Incidentally, the cost of rendering guaranteed free service over a ninety-day period is not high if the merchandise sold is of good quality, receivers and the tubes and loud speaker to go with them are tested thoroughly in the shop before delivery, the installation is a high-quality job in every respect, and the salesman has not made exaggerated performance claims. For example, the free calls made by the dealer whose service methods we have been discussing averaged only about one and one half per sale in 1928!

Labor Costs

Before we go into the subject of how much should be charged for service, it might be well to examine the cost a little more closely, for upon the latter depends the amount of the former. The chief item of service, labor, is the one real cost which is so generally under-estimated, and the one for which dealers almost universally under-charge their customers. The chart accompanying this article gives the details of the situation, which are taken from records of the service department of a highly successful radio retailer. The figures are an average of the cost of eight men over a period of two years.

The most significant thing about the figures is the fact that the amount actually

realized by this dealer's service department—which the author considers to be in the very top rank of efficiency—is only 67.5 per cent. of the amount which is his advertised and applied rate for labor per hour. That is something which is totally neglected in the accounting of the average service department. Figured on the same basis—of efficiency as measured by percentage of the labor charge which can be considered actual gross income from labor—the average dealer would *certainly* not be rated more than 50 per cent. That would mean, with the same cost, and the same charge per hour, that his income would be \$1.25 per hour, giving him a margin of only 19 per cent. to cover all of his service overhead. It has been the experience of large dealers with good service departments that it requires the *utmost* care to keep the overhead down under 40 per cent. If the average dealer is able, by careful planning, to keep his service overhead down to 40 per cent., or near that figure, but he does not make more than 20 per cent. on labor, his net loss on labor is not less than 20 per cent. and often more.

Sad to relate, the actual conditions are even worse. The average dealer computes, very roughly, that his labor costs him, even with fairly good men, somewhere between 60 and 75 cents per hour. Then he calculates that if he charges \$1.50 per hour for service he will have an ample margin, in the neighborhood of 50 per cent. and everything will be lovely! In the first place, they neglect the fact that if they pay a serviceman at a weekly rate which amounts to 75 cents per hour, the cost for the hours the man actually works will be very close to \$1.00 per hour. Then they also neglect the fact that a charge of \$1.50 per hour will bring in, even with the *utmost* efficiency, less than \$1.00 for each hour of work. The average dealer at the present time not only shows no gain on service labor with which to take care of service overhead, but he shows a loss before his overhead is deducted. There is just one answer to the problem: If good service is to be rendered, and the dealer is to break even on the labor item of his service, then \$2.50 per hour is the *lowest* rate on which he can base his charges to the customer!

STRAYS FROM THE LABORATORY

(Continued on page 40)

decrease appreciably. Such a voltage is not difficult to attain from local stations and may cause appreciable cross talk. Set engineers, therefore, are increasing the control-grid bias to as high as 3.0 volts in some cases and increasing the screen-grid potential from 75 to 90 volts.

It was said in July that the screen-grid tubes were none too good, some of them drawing grid current at a negative potential as high as 1.5 volts which means either increasing the bias voltage some more, or running the risk of cross-talk trouble, or of finding some way to avoid cross talk by circuit changes, or, of course, producing better tubes.

Why does a screen-grid tube seem more prone to draw grid current than other types of tubes? The chief reason is probably because of its unipotential filament. The 227 is another offender. The high-voltage-filament tubes, such as the Arc-turus 15-volt tubes, draw but little grid current and then only under conditions at which the tube would not be operated. If the filament has a high voltage, there is

only a very small part of it that can radiate electrons to the grid. On the other hand, if the filament has a low voltage, the wd-12 type for example, a large part of the filament will be near the voltage of the grid, and consequently can contribute to the grid current. Contact potentials and the initial velocity of the electrons play an important part in this grid current business—which worries both set and tube designers.

PROFESSIONALLY SPEAKING

(Continued on page 24)

to it. One of the leads shorted to the frame through a thin mica washer. A nickle's worth of tape fixed the difficulty and left enough for the owner's bicycle.

What is the moral to this story? There are two. In the first place the serviceman was a "dumb-bell." He belonged to an authorized dealer—but not authorized to carry the receiver which hummed so badly. He did not know how to isolate trouble. He was going to charge the customer a ridiculous sum of money to fix a difficulty that the manufacturer should

have avoided by careful insulation. This is the second part of the moral. The receiver manufacturer who made that set never should have used such a flimsy device as the single mica washer to hold back some 300 volts from going straight into the ground and ruining not only reception but a rectifier too.

This fault lies primarily with the manufacturer, secondarily with the serviceman. But granted that manufacturers must save money, why could not an intelligent serviceman have found the difficulty? Is it a fact that the average serviceman is as stupid as many people think? If this is true, the manufacturer must look the situation in the face and make receivers that will not go bad in service. It can be done.

Vreeland Tuning Patents

The Vreeland Corporation, 140 Cedar Street, New York, N. Y., states that the Vreeland "band-selector" patents make possible undistorted reception of the entire modulated wave and do not require "geometric" tuning. It is claimed that the Vreeland patents make possible a non-infringing r.f. system. "The Vreeland system," says its inventor, "may eliminate completely radio-frequency tuning."

SM

One Mile from WSM— 400 from WMAQ—and the 712 Cuts 20 kc.!

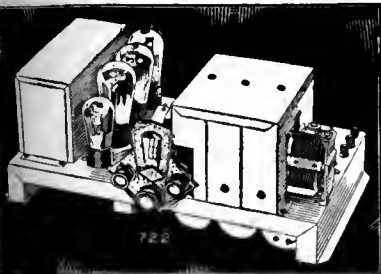

722 Band Selector Seven

Providing practically all 1930 features found in most new \$200 receivers, the S-M 722 is priced absurdly low in comparison. 3 screen-grid tubes (including detector), band filter, 245 push-pull stage—these help make the 722 the outstanding buy of the year at \$74.75 net, completely wired, less tubes and cabinet. Component parts total \$52.90. Tubes required: 3—'24, 1—'27, 2—'45, 1—'80.

Beautiful Cabinets

The handsome new 707 table model shielding cabinet, finished in rich crystalline brown and gold, suitable for 722, 735, or 735DC, is only \$7.75. Special arrangements have been made whereby these receivers may be housed in magnificent consoles especially adapted to them. Be sure to send for the new Fall S-M General Parts Catalog; for details of these cabinets.



Keep up-to-date on Silver-Marshall progress; don't be without THE RADIOBUILDER: New products appear in it in advance of public announcements. The October 15th issue, for example, described a new amplifier design for television reception, as well as hints on installing the wonderful 712 as the radio tuner unit in rack-and-panel installations. If you're not getting THE RADIOBUILDER regularly—use the coupon!

Big Opportunities This Year for S-M Service Stations

Custom-builders using S-M parts have profited tremendously through the Authorized S-M Service Station franchises. Silver-Marshall works hand-in-glove with the more than 3000 professional and semi-professional builders who display this famous insignia. If you build professionally, let us tell you all about it—write at once!

SILVER-MARSHALL, Inc.

6403 West 65th St., Chicago, U. S. A.

W. W. DILLON & CO.
Realtors, Nashville, Tennessee

"Silver-Marshall, Inc., Chicago:

"I have had your 712 tuner for about ten days now . . . over a hundred stations have been received . . . I live within a mile of the towers of WSM (650 kc.) but am able to bring in WMAQ (Chicago, 670 kc.) and KPO (Oakland, Calif., 680 kc.) . . . I find I get results on a short indoor aerial which you claim only when using a longer outdoor antenna . . . I am using 30 feet of rubber-covered wire tacked up in the attic . . . Some night I may put up a decent aerial, connect it as you direct and bring in China."

—M. G. Horkins

The custom-built S-M 712 used by Mr. Horkins is a straight one-dial all-electric tuner, as easy to operate as the cheapest radio. Whether it's a world-beating set for your own home, or a custom design to build for "fastidious listeners"—the S-M 712 so far overshadows competition that comparison becomes ludicrous.

And if You Prefer a Still Lower Cost—

"Silver-Marshall, Inc., Chicago:

"I received my 722 . . . That receiver is certainly the best for the money—KDKA or WBZ without any heterodyning at blasting volume, or WRVA and WPG, or WJZ and WBBM, or WEAF and WMAQ. (All four are 10 kc. separations.) WJZ, WGY, KDKA and CKAC, 400 to 600 miles away, are regular daylight features . . . I will keep on boosting Silver-Marshall sets like I have been doing since four years ago."—Gleason Belzile, Rimouski, Quebec, Canada.

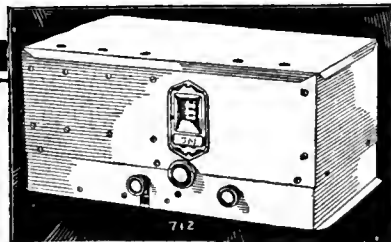

The New "Boss of the Air"—S-M 712

Far more selective and sensitive even than the Sargent-Raymont 710, the new all electric single control 712, with band filter and power detector, stands far beyond competition regardless of price. Feeds perfectly into any audio amplifier, the S-M 677 being especially suitable and convenient. The 712 can be easily mounted for use as radio tuner in a rack-and-panel amplifier installation; the superlative quality of its reception makes it ideal for this purpose, while the low-impedance power detector works perfectly into any type of power amplifier. Tubes required: 3—'24, 1—'27. Price, only \$64.90, less tubes, in shielding cabinet. Component parts total \$40.90.

677 Amplifier

Superb push-pull amplification is here available for only \$58.50, less tubes. Ideal for the 712, since it furnishes all required power (180 volts B, 2½ volts A.C.). Tubes required: 2—'45, 1—'27, 1—'80. Component parts total \$43.40.

Short Wave Reception Without Batteries

A screen-grid r. f. stage, new plug-in coils covering the bands from 17 to 204 meters, regenerative detector, a typical S-M audio amplifier, all help to make this first a short-wave set first also in performance. Price, wired complete with built-in power unit, less cabinet and tubes, only \$64.90. Component parts total \$44.90. Tubes required: 1—'24, 2—'27, 2—'45, 1—'80. Two extra coils, 131P and 131Q, cover the broadcast band at an extra cost of \$1.65.

Adapted for battery use (735DC) price, \$44.80, less cabinet and tubes. Component parts total \$26.80. Tubes required: 1—'22, 4—'12A. All prices net.

Silver-Marshall, Inc.

6403 West 65th Street, Chicago, U. S. A.

Please send me, free, the new Fall S-M Catalog; also sample copy of The Radiobuilder.

For enclosed . . . in stamps, send me the following:

..... \$0. Next 12 issues of The Radiobuilder

..... \$1.00 Next 25 issues of The Radiobuilder.

S-M DATA SHEETS as follows, at 2c each:

- No. 3. 730, 731, 732 Short-Wave Sets
- No. 4. 255, 256, etc., Audio Transformers
- No. 5. 720 Screen Grid Six Receiver
- No. 6. 740 "Coast-to-Coast" Screen Grid Four
- No. 7. 675ABC High-Voltage Power Supply
- No. 8. 710 Sargent-Raymont Seven
- No. 9. 678PD Phonograph-Radio Amplifier
- No. 12. 669 Power Unit
- No. 14. 722 Band-Selector Seven
- No. 15. 735 Round-the-World Six
- No. 16. 712 Tuner (Development from the Sargent-Raymont)
- No. 17. 677 Power Amplifier for use with 712

Name

Address

RADIO BROADCAST

WILLIS KINGSLEY WING Editor
 KEITH HENNEY Director of the Laboratory
 HOWARD E. RHODES Technical Editor
 EDGAR H. FELIX Contributing Editor



VOL. XVI. NO. 2

PUBLISHED FOR THE RADIO INDUSTRY

Contents for December, 1929

General Motors—And Radio	71
Changing Sales Conditions <i>Harry P. Bridge</i>	72
Radio's Advertising Budget—\$25,000,000 <i>T. A. Phillips</i>	74
What Is the Size of Your Slice? <i>Howard W. Dickinson</i>	76
The Jobber's New Place <i>A. H. Deule</i>	78
Tested Sales Ideas <i>Merchandising Shorts</i>	80
Field Crew Directed From Truck Inexpensive Publicity that Counts When Dealers Cooperate Making Money Out of Trade-ins	Try This Stunt in Your City Sell a Set to Your Doctor Making Outside Salesmen Pay Increasing Service Efficiency
How About Time Payments? <i>Howard W. Dickinson</i>	82
Professionally Speaking <i>Keith Henney</i>	84
Regarding Style Changes A Radio for the Farmer	Foreign Views on Advertising
House-to-House Selling Is Not a Sideline <i>Bayard B. Penrose</i>	85
Radio Pictures of the Month <i>A Page of Pictures</i>	87
Advertise What You Have to Sell	88
The March of Radio <i>An Editorial Interpretation</i>	90
Readjustment in the Industry What is Right with Broadcasting	Roasting Will Do It A Lesson for the Radio Industry
News of the Radio Industry	92
The Tube Business <i>News of the Tube Industry</i>	96
Strays from the Laboratory <i>Technical Shorts</i>	101
Regarding Synchronized Stations	Measuring Screen-Grid Capacity
In the Radio Marketplace <i>Offerings of Manufacturers</i>	102
The Serviceman's Corner	104
Electrostatic Loud Speakers <i>F. J. Somers and G. E. Maltos</i>	106
Setting Radio Standards <i>Kenneth W. Jarvis</i>	108
The Philco "05" Screen-Grid Plus Walter E. Holland and W. A. MacDonald	111
The Electrodynamic Loud Speaker <i>E. A. Uehling</i>	113
Development of the Pentode Tube <i>Friedrich Oskar Rothy</i>	116
"Radio Broadcast's" Set Data Sheets	118
The Crosley Models 609,610	The Day-Fan Model 5091
Radio Broadcast Laboratory Information Sheets— Howard E. Rhodes	120
No. 307. Frequency Band Requirements	No. 308. Frequency Band Requirements No. 309. Volume ex. Fidelity

The contents of this magazine are indexed in *The Readers' Guide to Periodical Literature*, which is on file at all public libraries

. . . among other things

GREAT RADIO hue and cry has been raised recently. Will the purging of Wall Street affect the radio market? There are prophets who stoutly maintain opposite positions. Sales of radios, automobiles, fine books, and whatnot will have a greatly restricted demand, one group says. The other says that radio sales are not influenced to any great degree by conditions on Wall Street. With this latter opinion, we agree. What of the fact that radio sales since the latter part of September and through most of October have shown a tendency to slow up? What of the rather general decrease in factory production of sets? What do the many announcements of sweeping price cuts mean?

ONE THING is certain: public interest in radio programs and radio merchandise is keen. Replacement tube sales continuing at a high level indicate that. But radio manufacturers have not yet learned how to gauge production to meet demands; they have not yet faced certain well-known and particularly serious distribution problems. Until the industry does this, each year is going to show a hurried readjustment of industry activity.

THIS MONTH the leading article in our department, "Professionally Speaking" brings up a question that is worth some thought: "To what extent are changes in radio receivers due to engineering advances and to what extent is pure 'styling' responsible?" Can you name any change in radio design for which style is primarily responsible?

READERS have been insisting for months that the "Home-Study Sheets" return to the pages of RADIO BROADCAST. Effective with our January issue, this feature will reappear. January will also see an increase in the number of Set Data Sheets with the addition feature of proper voltage and current readings to help those who use these circuits in regular service work with a test set.

IN JANUARY, we plan to present an interesting article on one of the remote-control systems which will be in the public eye in a few more months. Among the other features will be a description of the new RCA farm radio set, the Radiola No. 21, an interesting review of merchandising and engineering radio progress for the year 1929, and a description of an unusual radio merchant who makes his service department pay and pay well.

—WILLIS KINGSLEY WING.

TERMS: \$4.00 a year; single copies 35 cents; All rights reserved. Copyright, 1929, in the United States, Newfoundland, Great Britain, Canada, and other countries by

DOUBLEDAY, DORAN & COMPANY, INC., Garden City, New York

MAGAZINES COUNTRY LIFE WORLD'S WORK THE AMERICAN HOME RADIO BROADCAST SHORT STORIES LE PETIT JOURNAL EL ECO WEST

BOOK SHOPS (Books of all Publishers)

NEW YORK: <LORD & TAYLOR, JAMES MCCREERY & COMPANY, PENNSYLVANIA TERMINAL, 166 WEST 32ND ST., 848 MADISON AVE., 51 EAST 44TH STREET, 420, 526, and 819 LEXINGTON AVENUE, GRAND CENTRAL TERMINAL, 10 WALL STREET> ATLANTIC CITY: <2807 BOARDWALK> CHICAGO: <75 EAST ADAMS STREET> ST. LOUIS: <223 N. 8TH ST. and 4914 MARYLAND AVE.> CLEVELAND: <HIGHBEE COMPANY> SPRINGFIELD, MASS: <MEEKINS, PACKARD & WHEAT.

OFFICES

GARDEN CITY, N. Y. NEW YORK: 244 MADISON AVENUE. BOSTON: PARK SQUARE BUILDING. CHICAGO: PEOPLES GAS BUILDING. SANTA BARBARA, CAL. LONDON: WM. HEINEMANN, LTD. TORONTO: DOUBLEDAY, DORAN & GUNDEY, LTD.

OFFICERS

F. N. DOUBLEDAY, Chairman of the Board; NELSON DOUBLEDAY, President; GEORGE H. DORAN, Vice-President; RUSSELL DOUBLEDAY, Secretary; JOHN J. HESSIAN, Treasurer; LILLIAN A. COMSTOCK, Ass't Secretary; L. J. McNAUGHTON, Ass't Treasurer



PAM music in Peruvian park

MIK1D

In the Zoological Gardens at Lima, Peru (pictured above), and all over the world, you will find PAM Amplified entertainment enhancing the beauties of nature.

PAM'S crystal clear voice can be suited to blend with forest sounds or increased to be easily heard above the roar of motors at air meets.

All around you are opportunities of a similar nature.

These opportunities are found in hotels, clubs, excursion steamers, schools, hospitals, parks, theatres, auditoriums, dance halls, skating rinks and swimming pools, air ports, ath-

letic fields, boat races, outdoor services, etc.

To the pioneer dealer who first sees and grasps this opportunity in his locality comes the greater volume and profit.

A new 16-page bulletin giving mechanical and electrical characteristics, representative installations and many new PAM Amplifiers will be sent upon receipt of 10 cents in stamps to cover postage. When writing ask for Bulletin No. RB13.

Main Office:
Canton, Mass.

Samson Electric Co.

RMA

Manufacturers Since 1882

Factories: Canton and
Watertown, Mass.

"TUBE SALES JUMP"

7-SECOND ACTION
 Don't just *talk* about Arcturus' starting speed... let your customer hold the watch.



CLEAR, HUM-LESS TONE
 Nothing you can say about Arcturus' clear tone is as convincing as a two-minute demonstration.



LONG LIFE
 Show your customer, on the meter, that Arcturus Tubes easily withstand 75% more current than they are designed for. Then he will *know* why they hold the world's record for long life.

SAY THOUSANDS OF ARCTURUS DEALERS WHO SELL TUBES THIS NEW, CONVINCING WAY

Here's one A-C tube that is good enough to sell on *proved performance* instead of sales talk.

Its superiority is so evident that you can *show* your customers why it is better.

Just make the three easy tests shown in these photographs. Compare Arcturus performance with other A-C tubes, if you like. No question which tube your customers will buy.

Remember that Arcturus Radio Tubes help your business in many ways. Arcturus quality keeps your customers satisfied... Arcturus dependability holds your service costs down.

There's profit in the proved performance of Arcturus *Long Life* Tubes. *Demonstrate* their quality... and put your tube and set business on a better basis than before.

ARCTURUS RADIO TUBE COMPANY
 Newark, N. J.

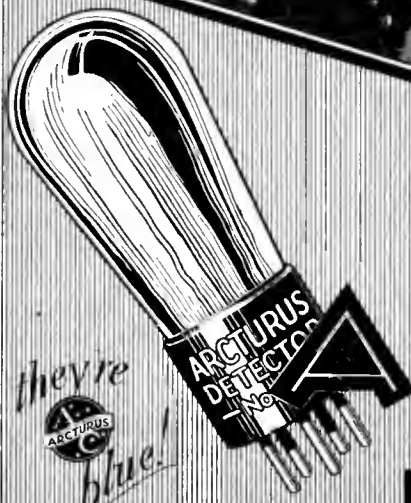

ARCTURUS RADIO TUBES

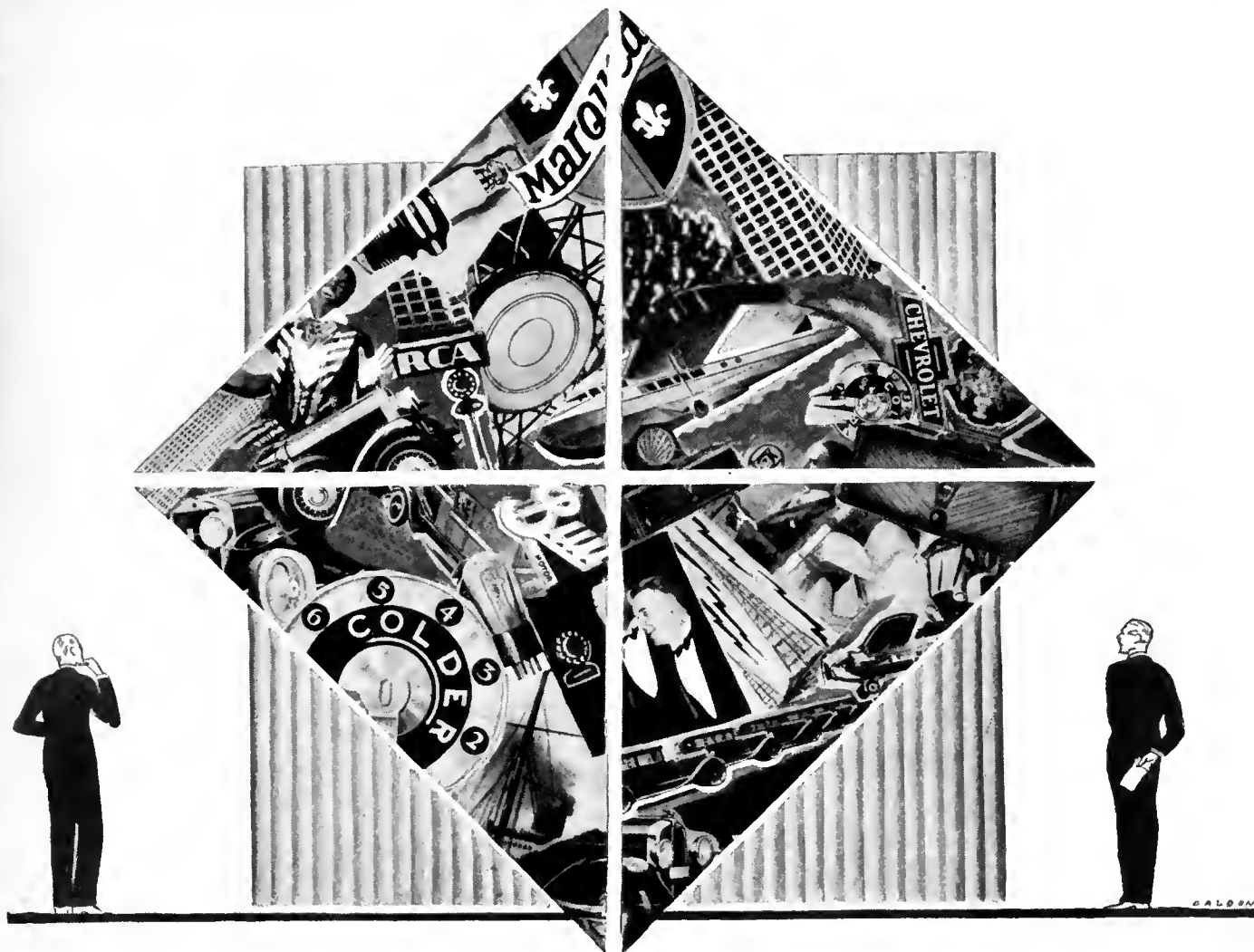

GENERAL MOTORS —AND RADIO

A NEW STAR has risen in radio. It is called the General Motors Radio Corporation, and early in October it was incorporated in the state of Delaware for \$10,000,000. The new company will manufacture and distribute apparatus covered by all the "Radio Group" patents "in radio, sound, and picture receiving and reproducing sets for use in homes and automobiles."

General Motors owns fifty-one per cent. of the \$10,000,000 of capital stock and Radio Corporation, forty-nine per cent. Management of the new corporation, as announced jointly by David Sarnoff, for RCA, and Alfred P. Sloan, Jr., for General Motors, will be in the hands of General Motors.

Nine men comprise the Board of Directors of which five are connected with the General Motors organization, two with the RCA, one representing Westinghouse, and one General Electric. The directors are:

John Thomas Smith, vice president and general counsel General Motors Corporation (chairman of Board).
 R. J. Emmert, president, General Motors Radio Corporation.
 James G. Harbord, president, Radio Corporation of America.
 John L. Pratt, vice president, General Motors Corporation.
 A. W. Robertson, chairman, Westinghouse Electric & Manufacturing Co.
 David Sarnoff, executive vice president, Radio Corporation of America.
 Alfred P. Sloan, Jr., president, General Motors Corporation.
 Gerard Swope, president, General Electric Company.
 C. E. Wilson, vice president, General Motors Corporation.

It is understood that General Motors will direct the new company through a separate executive personnel not yet announced.

The new company will have the widest manufacturing scope under the patents to which it has access. Radio receiving sets for home use, the superheterodyne circuit, electric phonographs, combination radio-phonographs, radio sets for automobile installation, and apparatus for still and motion pictures are all covered in the patents available for use by the General Motors Radio Corporation.

No official of any of the four companies represented in General Motors Radio has been willing to comment on how the products of the new company will be distributed. It is apparent at this time, however, that products of General Motors Radio will be separately designed, separately manufactured, bear a separate trade identity, and, unless some new development is uncovered, will be separately merchandised.

In an announcement to all Radiola distributors, J. L. Ray, president of Radio-Victor, says: "The Radio Corporation of America and its wholly owned subsidiary companies will continue independently as heretofore, to manufacture and distribute their own products. The General Motors Radio Corporation will manufacture its own product and develop its own distribution."

(Concluded on page 122)

This Retailer Is Meeting

CHANGING SALES CONDITIONS

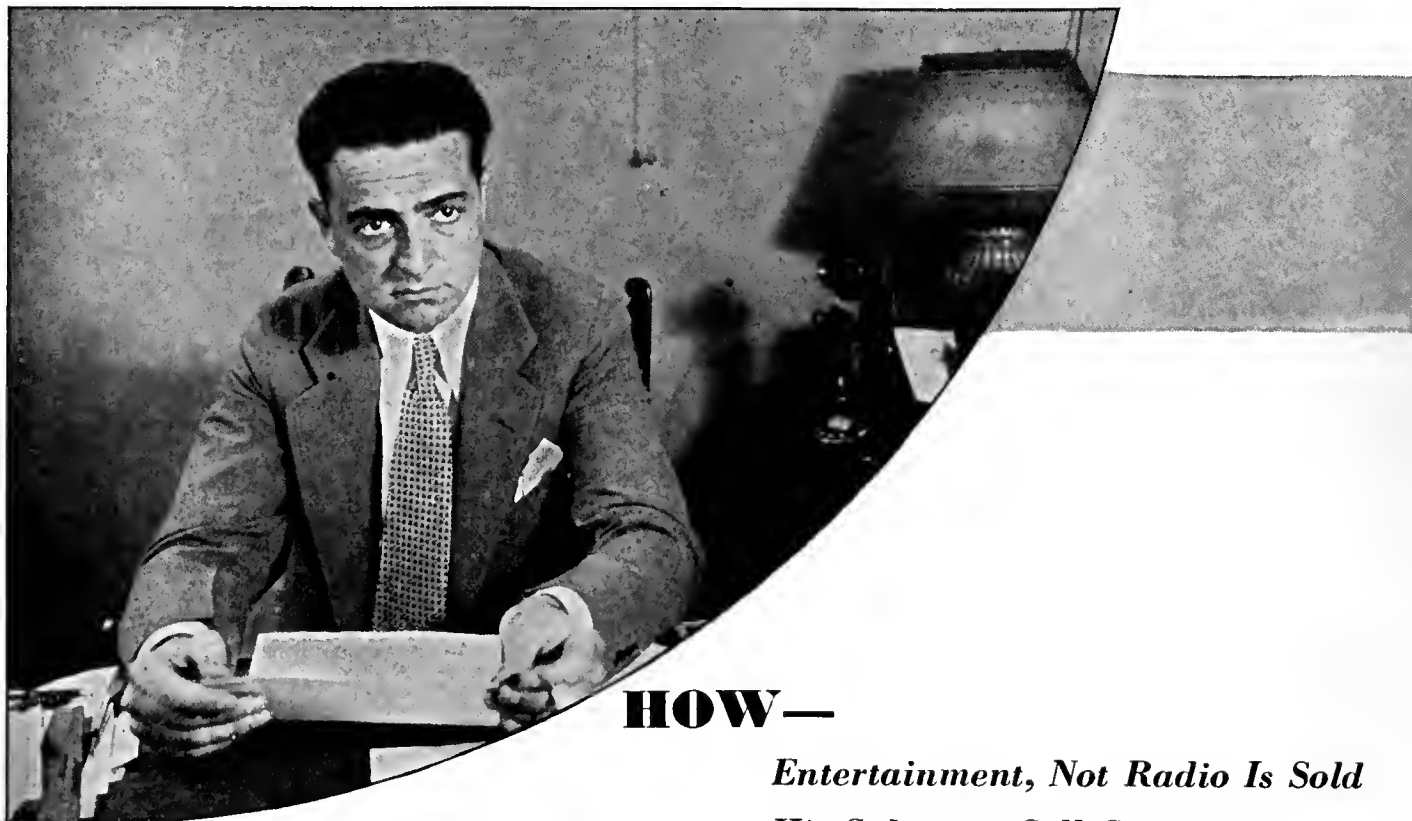

HOW—

*Entertainment, Not Radio Is Sold
His Salesmen Sell Constantly
All Store Visitors Are Prospects
No "Cold Turkey" Canvassing
Prospect Leads From Service Calls*

By HARRY P. BRIDGE, JR.

LET'S TAKE a good look at the man behind the radio counters of to-day and compare him with the type which will probably be there on the to-morrow that is already beginning to dawn. And to do this, let's go to the Universal Radio Company at the busy corner of Juniper and Arch streets, Philadelphia, Pennsylvania.

"Like the famous old gray mare, radio selling is not what it used to be," says Victor E. Moore, vice president and general manager of this concern. "In years gone by, when demand exceeded supply, radio literally sold itself. New developments made repeat buyers out of old customers without any great selling effort on the dealer's part.

"Now this spontaneous market is almost a thing of the past. Much of the novelty of radio has worn off; people have become more or less accustomed to it, and it has developed into a selling proposition much like the automobile, furniture, insurance, real estate, or any other legitimate business. And, more so now than ever before, radio is in need of that kind of selling."

Three Types of Men

There are, in this dealer's opinion, three types of men engaged in radio selling to-day—high-pressure artists, low-pressure men, and salesmen who strike a happy medium between the two. Much of Mr. Moore's time has been devoted to selecting men of the latter class for his organization—or those of the former type who could be led to change their ways.

"In building for the future," says Mr. Moore, "the high-pressure man is almost as useless as the fellow who has no sales pressure at all. The former relies on one-time sales to customers who don't come back and the latter lets perfectly good sales slip through his fingers because he lacks initiative. There are a lot of both engaged in retail selling to-day and the dealer's

problem in building a really aggressive and alert sales organization is not an easy one."

Mr. Moore chooses his men carefully, but his work does not end with the selection. That is only the beginning. He believes it is just as important for the retailer to exercise close supervision over the selling efforts of his organization as it is for the manufacturer or wholesaler. Every effort is made to help each man increase his efficiency and thus add to his own earnings as well as those of the company. But, if a man cannot fill the bill, the sooner this is discovered and the man dropped, the better it is for all concerned.

A Salesman Loses His Head

Not long ago, a Universal Radio Company salesman was on the point of closing a sale for a radio-phonograph combination. The outfit had been demonstrated in the home of a well-to-do woman and she was well pleased. However, when the salesman produced the contract for her signature, she said she had decided to hear one more outfit from another dealer before making a final decision.

"My salesman lost his head when he heard this," said Mr. Moore in describing the incident. "He'd been having a little run of hard luck and I had been after him to produce some sales. This one had seemed so sure he got rattled when he suddenly found there was still a chance that it might be lost. Putting the rectifying tube in his pocket he told her there would be no further concerts until she decided to buy. He added that

The Universal Radio Company's store at the busy corner of Juniper and Arch Streets, Philadelphia, Pa.



The large show room in the Universal store where several makes of radio receivers are attractively displayed.

the truck would call for the set in the morning unless she decided in the meantime.

"Well, for the salesman to lose his head in this manner was the best possible way to get the prospect to do the same thing. As a result she called on the phone, to tell us we didn't need to wait until morning to get the set. I immediately went out to see her myself, apologized for the salesman's action, restored the missing tube and, by the time the other dealer arrived, I was leaving with the contract signed. It is often very easy to come to an understanding from a misunderstanding such as this, and that is exactly what had happened. But that is not the point. The important problem was what to do with the offending salesman.

"He had not been with us long and my natural inclination was to let him go. However, I had thought the man had possibilities when I hired him and still thought so. Good salesmen are not easy to get and if one has good in him, I have found it worth while to try and bring it out.

"Accordingly, I called the fellow into my office and had a heart-to-heart talk with him. I told him there were two things he would have to do. First, he was to go to that lady and apologize and, second, he was to keep a better grip on his temper. In the third place, I told him he was going to get the commission, for, even though he had not really made the sale, he had done most of the work.

"The plan worked. The salesman felt he was as good as 'fired' when I called him into the office, but he was ready and willing to make good if he were given another chance. Within the next couple of days, he sold two expensive sets and to-day he is one of the best salesmen on our staff."

Careful Sales Supervision

Despite its central city location, the Universal Radio Company would not be so successful to-day were it not for salesmanship and sales supervision of a high order. As a single instance of this may be taken the answer to the old query: "What does a salesman do when he isn't selling?"

At the Universal Radio Company, there is no time when the salesman is not directly engaged in trying to make a sale. Salesmen are paid for their ability in that direction. Other jobs are left to other men. Mr. Moore's sales staff consists of five carefully selected men. Only one is to be found on the floor at any time during the day. The rest are kept busily engaged calling on their own prospects as well as those whose names are furnished by the firm. If there is a sudden rush of business at the store, Mr. Moore "pinch hits" and additional

recruits can be had from the service department as needed. This arrangement has proved particularly helpful in connection with the manager's ideas on using up-to-date methods for selling radio.

By a little tactful handling, the names and addresses of all people who visit the store are obtained. Then, if an interested party does not come back within a reasonable time, the salesman who met him does not delay. Out he goes to visit the prospect at his home—and frequently he comes back with the latter's request for a home demonstration.

Many leads are obtained by the company as a result of its advertising as well as the activities of servicemen who are almost as adept at searching out prospects as they are at fixing balky outfits. These are allotted among the salesmen who are required to report on each visit. Naturally these leads do not result in as many sales proportionately as the prospect list of those who have already visited the store. But such selling has proved well worth while. Incidentally, no "cold-turkey" canvassing is done.

Salesmen Sell Entertainment

Save in a few instances, where customers are technically inclined, Universal Radio Company salesmen do not sell radio. They sell *entertainment*.

A salesman is required to know something about radio and also to be able to talk in the proper vernacular to the dyed-in-the-wool radio enthusiast. More important, however, is the fact that he is urged to keep abreast of all important broadcasts. The Universal Radio Company is owned by the operators of radio station WCAU, situated on the top floor of the same building, and for this reason, perhaps, those at its head are keenly aware of the importance of broadcasting in promoting the sale of radio.

"Our salesmen talk entertainment," says Mr. Moore, "and they try to find what sort of entertainment particularly interests the prospect in question. Once this is discovered, they take advantage of it by referring to broadcasts of note along that line and by demonstrating programs of that kind whenever possible."

Every Universal salesman is carefully instructed to sell radio for just what it is—no more, no less. No claims that cannot be substantiated upon demonstration are made for sets. Prospects are led tactfully but surely to realize that no radio is perfect—but that a good radio in the home offers a mighty interesting box seat at the vast Theatre of the World. They are

(Concluded on page 124)

RADIO'S ADVERTISING BUDGET

\$25,000,000

DURING 1929, the radio industry spent \$25,000,000 for all forms of national advertising. This huge sum is only 3.8 per cent. of the probable sales for the same period. If 3,000,000 radio sets are sold in 1929 this means that \$8.35 will be spent by the industry to advertise each complete set, including tubes, loud speaker, cabinets, etc.

The information presented in table form on these two pages shows all available facts about national radio advertising expenditures. The second table on this page indicates how radio as an industry ranks in newspaper advertising expenditures with other leading businesses. Radio, it will be seen, ranks well up among the leaders. In newspaper advertising, forty set manufacturers filled 80 per cent. of the space bought by the radio industry. The six set manufacturers who bought newspaper lineage in large volume in 1928 are: Company A, 3,900,000 lines; Company B, 3,050,000 lines; Company C, 2,069,000 lines; Company D, 1,584,000 lines; Company E, 1,583,000 lines; Company F, 1,269,000. (Makers represented here include Crosley, Sparton, Majestic, Kolster, Atwater Kent, and RCA.) It is likely that the 1929 figures for newspaper lineage will show about the same relation, although total newspaper expenditures by radio advertisers in 1929 will show an increase of 29 per cent.

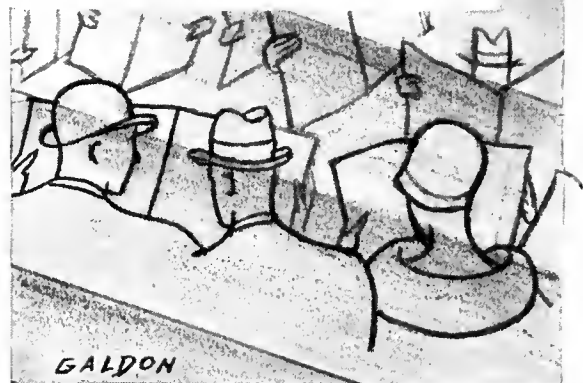

How Radio's Advertising Is Distributed

(National advertising expenditures in various media by radio industry)

	1928		Increase	% of total	
		(2)		1928	1929
Newspapers (1)	\$7,500,000	\$9,725,000	29%	41.7	39.0
Magazines (3)	2,500,000	3,400,000	36%	13.9	13.5
Trade Magazines (4)	1,250,000	2,000,000	60%	6.9	8.0
Broadcasting (5)	1,825,000	3,500,000	91.5%	10.1	14.0
Talent (6)	465,000	800,000	72%	2.6	3.2
Direct Mail and all other types (7)	4,460,000	5,575,000	29%	24.8	22.3
	\$18,000,000	\$25,000,000			

- 25,016,155 lines in 369 newspapers in 77 cities reported by Sales Management.
- Based on increases reported by Survey of Current Business.
- Publishers Information Bureau.
- Special report made for Radio Broadcast by P. I. R. Covers period from June 1928 to July 1929.
- Time charges on N. B. C. and Columbia—courtesy of Glen W. Foster, of Columbia Broadcasting Co.
- Estimated by Mr. Foster
- Estimated on basis of research conducted by Sales Management.

National Advertising in Newspapers

(Compiled by Media Records for Sales Management)

IN 369 NEWSPAPERS
(70 Cities)

Product	No.	Lineage	Total % of
Automotive	218	161,105,000	31.97
Groceries	498	77,880,789	15.43
Medical	456	64,572,697	12.81
Tobacco	91	41,088,460	8.16
Toilet Articles	232	38,355,088	7.61
Transportation	179	30,942,884	6.10
RADIO	104	25,001,999	4.96
Electric Appliance	71	12,711,191	2.52
All Other	736	52,408,153	10.44
Totals	2585	501,066,261	

IN 70 ROTO SECTIONS

Product	No.	Lineage	% of Totals
Automotive	26	1,694,756	17.80
Groceries	33	1,647,162	17.34
Medical	38	1,085,987	11.43
Tobacco	9	903,111	9.51
Toilet Articles	63	2,254,844	23.74
Transportation	17	71,829	.76
RADIO	4	44,156	.47
Electrical Appliances	12	395,138	4.16
All Other	92	1,397,025	14.79
Totals	294	9,494,008	14.79

How Trade Advertising Is Divided

Kind of Account	Number of Accounts	Cost of Space	Percentage of Cost
Radio Sets—Mfrs.	70	\$386,148	31.94
“ “ —Jobbers	54	47,567	3.94
Loud Speakers	51	92,969	7.69
Furniture	59	74,074	6.13
Tubes	53	197,343	16.32
Parts	257	236,447	19.56
Sub Total	544	\$1,034,548	85.58
Phonographic	82	118,906	9.83
Miscellaneous	75	55,482	4.59
Totals	701	\$1,208,936	100.00

Figures Showing How and Where Radio Manufacturers Have Spent Their Advertising Appropriation

By T. A. PHILLIPS

Manager, Research Division,
Doubleday, Doran & Co., Inc.

The industry is spending large sums in trade magazines as the table on this page shows. These figures, incidentally, are presented for the first time anywhere. The figures are based on actual count of the leading publications in a survey made by Publisher's Information Bureau especially for RADIO BROADCAST. It is worth noting that an increase of 60 per cent. in trade advertising is estimated for 1929. The supplementary table shows how this trade advertising is divided into various classes.

During 1929, radio companies have spent about \$3,500,000 for time over the two leading national networks and an additional \$800,000 for talent, according to an estimate of Glen W. Foster of Columbia. Total estimated expenditures for broadcasting throughout the United States by all advertisers for 1929 are estimated by Mr. Foster at \$60,000,000 for time and \$15,000,000 additional for talent. It is evident here that radio manufacturers are bearing their share of support of the broadcasting industry.

All the figures presented here, with the exception of advertising expenditure in trade publications, do not include advertising of musical instruments or phonographs and accessories for these two classes of merchandise.

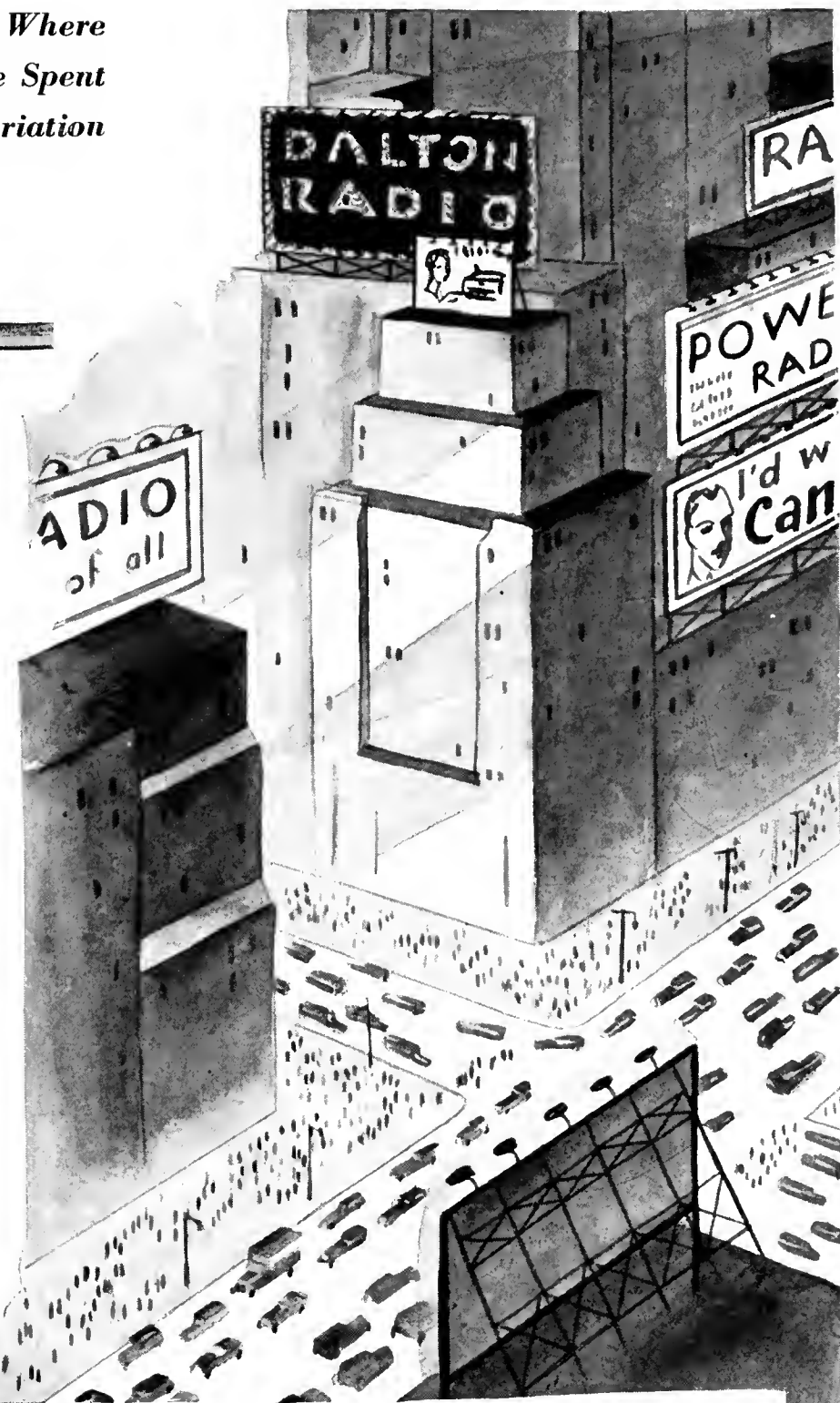

Radio Advertising Expenditures by Territories in Trade Media

TOTAL ADVERTISING EXPENDITURE ALL MAGAZINES
(By Territories and Classifications of Accounts)

Territories	Radio Receivers (Mfrs.)	Loud Speakers (Jobbers)	Radio Furn.	Tubes	Parts	Phono-graphic	Misc.	Total
N. Y. City	\$116,694	\$10,001	\$22,388	\$17,808	\$79,641	\$62,217	\$71,418	\$33,858
N. Y. State	18,927	220	4,438	404	—	6,362	—	525
N. England	4,174	99	2,455	1,392	46,285	27,722	3,342	4,338
Pa. & South	70,167	8,713	12,422	13,702	42,872	29,154	1,422	6,077
Chicago	111,184	22,592	44,492	17,785	22,581	56,378	12,351	9,255
Michigan	35,971	5,342	807	7,763	—	17,972	455	91
Ohio	10,917	297	—	285	1,053	13,524	1,360	171
Mid West	17,732	300	5,880	11,935	4,911	21,571	21,131	1,165
Far West	382	—	87	—	—	1,514	—	—
Foreign	—	—	—	—	—	—	1,424	—
	\$386,148	\$17,567	\$92,969	\$74,074	\$197,313	\$236,417	\$118,906	\$55,482
								\$1,208,936

WHAT IS THE SIZE OF YOUR SLICE?



By HOWARD W. DICKINSON

Merchandising Consultant

SPEND MONEY in advertising. Use the power of that advertising to maintain prices. By taking full profit per sale make the business pay.

Why is it that so many dealers recognize the force of these three commands and yet fail to get their full price for either merchandise or service?

Is any one thing in retail selling more important than to find out why this difference exists between right and provable theory on the one hand and common dealer's practice on the other?

Every dealer wants full price and full profit. By all sound laws of commerce he should have them. What prevents his taking them? *Should* those things prevent the dealer from taking them? What remedy has he in his own hands to cure the situation?

There are no more important questions than these among all the complications of buying and selling for a profit. We accept sound theory as theory, then, in practice, we go out and give away the shirts off our backs because someone else seems to be doing so.

Lopping off a legitimate price is easy. Doing a sweet and convincing job of advertising is harder. Is that the reason?

Let us consider some of the price and profit conditions which every retailer in radio is up against.

The Dealer's Problem

Here is what they face, dealer's discount about 40 per cent.—overhead, sales cost, and so on from 30 to 35 per cent. and rarely less. It takes an exceptional financier to reduce costs below that and maintain a business which gives the impression of self respect and wholesome prosperity.

Let us figure on an average 8 per cent. profit—the man who beats that and also makes his business grow, does very well indeed. The man who gives away materials, does wiring free, carries heavy unpaid customer balances without interest charge, gives away more than a sound business man can afford to. He is pretty sure to run way below 8 per cent. profit on his turnover unless he starves his advertising and sales work and charges up his extra service against his advertising account.

It is a costly habit to charge against advertising any

item which *might* help build good will, because in this way many a man has had a heavy account charged to "advertising" without having had any advertising.

The good will to be obtained by gifts of expensive service and disproportionate allowances can be overestimated very easily. It may have some value—but a customer once sold can be profitable again only as he wants parts, repairs, and ultimately perhaps a new set, and if he has received more free than his due he is apt to be a "spoiled" customer.

Sooner or later an intelligent dealer must learn the relative values to himself of straight advertising and so-called advertising by generous concessions. He must learn which kind of customers pay him best, the "gimme" type of people or the people who pay for what they get and expect others to pay them for what they in turn give or do.

Do the majority of people want "gimme" service or straight businesslike service?

Is "gimme" service demoralizing to the business which advertises by gifts instead of with advertisements?

Are sales which cost more than their gross returns the kind of sales which make it interesting to do business?

Can the dealer who begrudges money spent in straight advertising build the business to success by letting his customers pull his leg with respect to the high-priced time of his expensive service force?

Does it seem foolish to ask these questions? By no means, so long as many dealers are kidding themselves into losses instead of profits and unintentionally demoralizing the market for those dealers who are trying to do business in a businesslike way.

Sooner or later we've got to come to a serious consideration of finance, either to be able to count our profits or to figure out what we've got left for our creditors.

Let us imagine this financial situation. A dealer has just sold \$2000 worth of sets on installments. He has a book profit of \$800 on these, but only \$500 cash because he has disposed of them on a 25 per cent. down basis and is carrying \$1500 on deferred payments. He can hardly carry that for less than 8 per cent. allowing for interest collections, defaulted payments, deterioration on good returns, etc.

If these payments run over a year's period, he must deduct

GET YOUR SHARE

Charge Full Price for Merchandise, Financing, and Service. Be Careful When Charging Good-Will Gifts to Advertising. Make Your Newspaper Advertising Pick the Right Kind of Customers—Avoid the “Gimme” Type.



\$120 at least for “carrying” from the \$1500 that he must get back. So instead of \$2000 he gets only \$1880.

So here we are—

Sales	\$2000
less 32%	640 (general cost of maintaining business)
	<hr/>
less	\$1360
	120 (deferred payment cost to dealer)
	<hr/>
less	\$1240
	1200 (actual cost of \$2000 in mdse at 40% off.)
	<hr/>
	\$40 profit to dealer

which is 2% of a \$2000 turn over.

Not enough profit. His stingiest “gimme” customer will admit that it is not enough profit. If installments stretch out for a year it means 2 per cent. per annum.

(Note. If the business were on a cash basis and there were 12 turnovers per year at 2 per cent. each it would make an annual profit of 24 per cent. which would be quite interesting.)

Suppose now our dealer realized that it was costing him 8 per cent. or more to carry deferred payments and he added a 10 per cent. financing charge for safety and profit on this financing. (That is done in many lines)

Then we should have these figures.

PICK YOUR CUSTOMERS



Sales	\$2000
less 32%	640 (general cost of doing business)
	<hr/>
plus	\$1360
	150 (10% charge for financing \$1500)
	<hr/>
less	\$1510
	120 (8% cost of financing etc.)
	<hr/>
less	\$1390 net
	1200 (actual cost at 40% off)
	<hr/>
	\$190 actual profit to dealer

which is 9.5 per cent. of \$2000, and is 4½ times as much profit as \$40 or 2 per cent.

It makes no difference whether these figures are accurate or average or what. There is some such financing problem in connection with any charge account or deferred payment business, and those business men who recognize this fact and act accordingly are the ones who are going ahead the fastest.

Many people think that concessions, free service, and so on are profitable advertising but it is seldom that they are. They are mostly sucker bait where the man who baits the hook is the sucker himself.

Contrast this expensive habit with the habit of advertising well, keeping your name and your offerings before the people in your town, presenting the dignity of a business which puts its best foot forward in public prints, and giving the impression of a straight, profitable, up-to-date demonstration of articles which are obviously worth their price.

Let us say our 30 to 35 per cent. overhead carries some advertising cost. If the “gimme” idea is in the merchant’s mind he will advertise his *concessions* more than his *goods*. That will bring more “gimme” customers and still more carrying costs, free service, and risks of default and returned merchandise. In that way he may be advertising to increase his losses, spending money to help himself lose money.

If newspaper advertising is businesslike, featuring the goods, the quality of the shop, and the high-grade character of standardized service at standard prices, it should bring the better class of customers, the kind that recognize their responsibility for paying legitimate bills, customers who, if they need financing will see the reasonableness of paying for it. If a decent man doesn’t see it in that light he can be made to as experience in many lines has shown.

Here is the great trouble. It is a psychological rather than logical trouble. The straight-line dealer is apt to over-estimate the yearning of the public for “bargains.” Bargain hunting is a sport with a considerable following, of course, but advertising has created a bigger following for the sport of learning about interesting goods and paying the price for them.

THE JOBBER'S

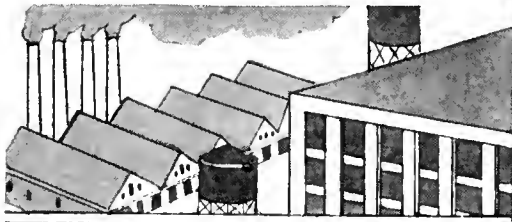

NEW PLACE

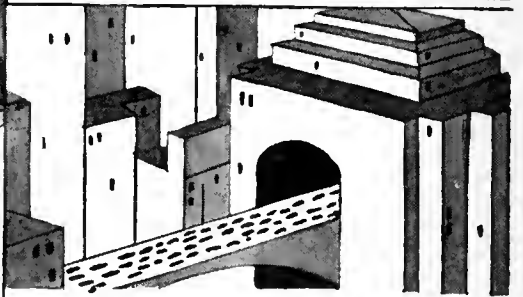

A Reprint from *Printer's Ink*

By **A. H. DEUTE**
General Manager, Billings and Spencer

A FEW MONTHS AGO, just as a new man was about to tackle the sales problems of the Glastonbury Knitting Company, I said to him: "What are you going to do about the jobbing situation? I understand that the Glastonbury line has been marketed entirely through jobbers."

Stanley Klein was this newcomer in the knit-goods industry, and he said to me frankly: "I haven't any idea. The off-hand impression is that the jobber is a thing of the past, especially in the knit-goods and dry-goods industries. So, off-hand, one might say that we'll look elsewhere for our distribution."

"However, I'm not going to scrap anything on hearsay. First, I'm going on the road and have a look."

He has returned from his trip and the first thing he said to me was: "I'm for our jobbers 100 per cent! I'm not for them 100 per cent. as they are working just at this moment, but I honestly believe that enough jobbers see the way in which they must be going to make it well worth while for the manufacturer who has been allied with them thus far to continue in his course."

Klein, who had made an outstanding success in the hardware and kindred industries, went into the knit-goods industry without prejudice, and his viewpoint develops an interesting angle.

It is this: Old-school jobbers, like many old-school retailers, were so deeply rooted in their theories and prejudices that it has taken several years of severe jolting to shake them loose from these beliefs. This jolting process has been so severe that it has proved fatal to an untold number of retailers and to a great many jobbers. But while it has proved fatal to many there is no evidence, so Klein believes, and I agree, that the jobber is to be a thing of the past, any more than that the individual retailer is apt to become a thing of the past.

On the other hand, there is much evidence to prove that the individual retailer and the jobber who serves him must both change their ideas, theories, and methods—change them radically and quickly. In other words, both of these groups must drop out or change to conform with the newer conception of merchandising. Neither can remain where and as he once was.

In what way must the jobber change so radically?

The answer is this: The jobber must change from a buyer at heart to a seller at heart.

Talk to the average head of a jobbing house. Look over his organization. The outstanding point of interest is that you will see not one or two buyers, but a group of them—possibly a dozen or more. Over against that group of a dozen or more buyers, you will probably not find a single competent sales manager. Personally, I can count on my fingers, and not have any need for thumbs, the men connected with wholesale houses who honestly consider themselves *real* sales managers. The great majority who have the title of sales manager will admit that they are either desk order clerks or that their main job is to get out the order sheets which the buyers prepare and check over the salesmen's expense slips. Others will tell you that their principal work is to go over the salesmen's orders and either price the items or approve the prices the salesmen have set. And woe betide the individual who undertakes to argue prices with the salesmen.

There you have the set up of nine jobbing houses out of



IN MERCHANDISING

Looking to 1935 the Jobber Will Change at Heart From a Buyer to a Seller, and This Change Is Being Reflected in the Changes Made by Up-to-Date Retailers, too. A New Highly Efficient Merchandising Set-Up Will Be Established

ten. On the one hand you have a group of buyers whose job it is to buy as cheaply as possible.

On the other, you have a group of men on the territory, who, all too frequently, run their territories as they choose and make prices as they choose, subject only to certain set minimums. Each man sells what he feels like pushing. As one of these so-called sales managers said recently, rather bitterly: "If we'd only realize it, all of us on the inside are just menials doing detail work for the salesmen."

I have met hundreds of jobbers in various lines, but I cannot recall a single one who is taking as much personal interest in the business of selling as he does in buying. As I recall them each man stands out first of all as a buyer.

The head of the house talks and thinks "buying right." But when he thinks of "buying right," he isn't putting his buying thought in tune with selling.

There is a reason for that. Over a period of years, the manufacturer has become more and more the brand builder. The jobber has become the man who hands out what the dealer has call for. He has looked upon himself less and less as a brand builder. His primary thought has been to get demandable merchandise and get it at a minimum price. It has become a deep-rooted habit. Many of the present-day jobbers have had no opportunity to think along other lines. As jobbers they are first of all buyers—and good, close buyers—and they have trained their young men in this way.

And the individual retailer, who has learned what he knows about merchandising largely from the jobber, has followed in the same channel.

The Chain Store Enters

Now we have the chain stores. It does not require much study to convince one that the great difference between the chain store and the jobber-retailer lies in the fact that the former is not only an expert buying organization but *particularly* an expert selling organization.

This, in brief, is the result of the study which Klein made in a general tour of the country. But his study demonstrated one more fact—there are enough jobbers who have come to realize that they must make selling a fifty-fifty partner in their business to make it seem worth while for the manufacturer to give them a chance.

What the future of the jobbing industry is apt to be and what the future of the jobber as we have known him is going to be are now quite well defined. He has taken a definite position in the industry of distributing and even the casual observer can detect this position with accuracy. There is no longer any more guess work.



The jobbing industry will continue, it will continue as a definite factor, and it will soon commence to do a larger percentage of the gross business than it is now doing. I feel that one is safe in saying that jobbing, as a business, is now at the lowest ebb in which it will find itself in the present-day merchandising cycle.

The old-school jobber is winding up rapidly and definitely. And it is not so much the chain-store method of distribution that is winding him up but rather the new school of jobber.

The old-school jobber—the jobber as we have known him during the last twenty-five years, ever since, in fact, he ceased to be a brand builder—that type of jobber who put his mind upon buying and made buying his fetish with selling just a mere detail—is giving way rapidly.

Taking his place is the new school of jobber who is as much concerned with the selling end of his business as he is with buying. This new jobber is already with us. It is not his own selling which concerns him so much as it is the proper merchandising of his lines so that his retail outlets can in turn sell what they buy.

A Sales Lesson From A Golfer

One of the really good golfers in the country told me once that he always plays over in bed, the night before, the match which he is scheduled to play the next day. Before retiring for the night before his match, he walks slowly and thoughtfully over the course, getting a mental picture of each hole. Then in bed that night he works out his game. The next day he plays it that way, regardless of what his opponent is doing.

It might be equally sound for many a sales manager to plan his selling five years from now in the same way. So, just as the golfer looks over his course in advance, let's look over the jobbing situation in 1935. Let us take the present trends and indications and extend the line ahead five years.

Here is the jobber of 1935!

The most advanced jobbers are going to be the drug jobbers. The next most advanced group will be the grocery jobbers. Then will come the hardware jobbers. And then the dry goods jobbers. There will be outstanding jobbers who will stand out in front of their groups, but as groups the foregoing seems reasonable, based on where they stand at present. And their present position is due to the pressure which chain stores have thus far brought to bear.

In 1935 the old-style jobber sales force will be quite thoroughly out of the picture. That is going to be so because retailers will not have to be talked into what to order.

The great mass of worth-while dealers will be grouped with one jobber or another. The jobber will have closely knit working arrangements with a given number of retailers—based on an economical minimum. But whether there be 250 or 500 or more retailers aligned with a given jobber, those retailers will work as a group—as a body.

As nearly as practical, the retailers will be
(Concluded on page 122)

TESTED SALES IDEAS

Dealer Directs Field Crew from Truck

THE FOLLOWING is an outline of a plan, now in use by a Bosch dealer in one of the largest cities in the country, which is netting more than 20 set sales a week:

1. Operates from truck stocked with various types of consoles and table models. Parks truck in central location from which men radiate to make house-to-house calls.
2. Uses four men in addition to sales manager who travel with the truck.
3. Pays men 10 per cent. commission on "cold" sales, 5 per cent. on "store-lead" follow-ups.
4. Men seek demonstrations, not sales, and find that time should not be wasted on totally disinterested people.
5. Within a few minutes of the time the permission is secured, the truck delivers the radio set and the sale is started.
6. Three days later the truck calls and either the sale is consummated or the set removed.
7. Terms are not less than 20 per cent. down, and 10 months in which to pay the balance.
8. The sales manager is always within "a stone's throw" for decisions on all matters beyond the authority of the salesmen. Trade-in and credit matters are quickly settled. He is near at hand for reinforcement when necessary. His availability serves to encourage the men.

Inexpensive Publicity That Counts

MR. SPECKER, of the G. & S. Sales Corporation, East Chicago, Ind., believes in getting Kellogg sets before the public eye by displaying them at public places. He learned that St. Mary's Church in his city was to have a bazaar early in May, so he decided that he wanted to sell a Kellogg receiver to the church to be raffled off during the bazaar, not only for the profit but also for the fine publicity that would result. Mr. Specker convinced the church committee that it would be to their advantage to place the set on display three months in advance of the bazaar so as to get people talking about it and arouse greater interest.

What Happens When Dealers Coöperate

SEVEN RADIOLA dealers in Richmond, Virginia—seven keen merchants—seven keen managers—coöperate with each other by meeting once every month to discuss happenings of the preceding month and analyze conditions. The seven men are free-traders in ideas. One of these dealers was once asked, "Why are you willing to divulge your selling ideas to these six competitors of yours?" The answer was, "Because I am sure that these men know as much about selling Radiolas as I do. They have been in business a long time; some of them as long as I have, others much longer. Every time that



Each Month These Pages Serve as Our Clearing House For Merchandising Ideas of Proved Value. Every Radio Dealer Should Read Them Carefully

I go to one of our meetings with a good progressive sales idea, I am pretty sure to come home with five or six additional ones that are just as good as mine." Whenever a new set is introduced by RCA these dealers advertise coöperatively in local newspapers to make a perfect tie-in with the regular RCA advertisement. These seven dealers know their market; and experience has taught them what to do and when to do it. At regular intervals these dealers sponsor and pay for excellent programs over one of their local stations. These seven dealers are: Johnson & Morris, C. A. Baylor Company, Rountree Corporation, Whitten Brothers, Edgar M. Andrews, The Corley Company, and Petit & Company.

Making Money Out of Trade-ins

How to realize a profit on sets taken in trade is a problem to every dealer. Some dealers are satisfied to close them out for what they can get while others feel that they must realize as much as, or more than, was allowed. One of the ways to get your money out of these sets is to use them for renting.

Your local hospital is full of good renting prospects. Arrange with the superintendent to furnish receivers on request to

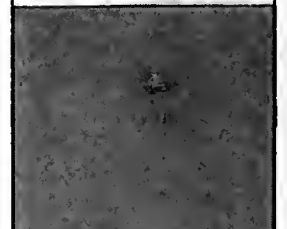
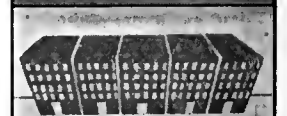
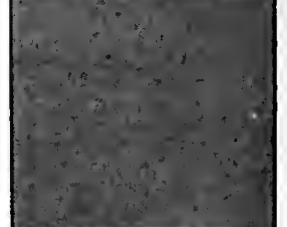



\$5.00 FOR YOUR PET SALES IDEA

patients. There are always a number of convalescents who would enjoy radio entertainment. You will find you can do a lot of business at \$1.50 a day per set. Your trade-in sets working for you at this rate will soon pay for themselves.

Try This Stunt In Your City

THE GARDNER RADIO SALES, Kendallville, Ind., dealer in Bosch screen-grid radio, recently sponsored a novel publicity stunt which aroused much interest there.

When the circus came to town a few weeks ago, officials of the firm obtained the use of a large elephant (not a white one). The Gardner Radio Sales featured Bosch screen-grid radio on a banner which was placed around the pachyderm and thus paraded through the city streets.

Sell a Set to Your Doctor

SELL A SET to every professional man or woman in your community. Have you ever wondered, as you sat and waited in the reception rooms of your attorney, your physician, or your dentist, why time hung so heavily on your hands? Think of the times you have sat and twiddled your thumbs while you shifted your eyes from the floor to the wall and then to the faces of other "clients" or "patients."

Here's the idea. Sell a receiver for use in these reception rooms. Show how it will keep clients and patients in a cheerful mood. In many cases the idea will appeal and you have created a new outlet for business. We suggest that you offer to make a trial installation in your doctor's reception room to-day.

Making Outside Salesmen Pay

IHAVE SELECTED a line of merchandise—Atwater Kent—that is nationally advertised. There is less sales resistance to it, and I'm not obliged to spend half of my selling time in trying to convince customers that it is just as good as some other radio.

I am not afraid of using newspaper space because I believe the newspaper is better than many other forms of advertising. I run good-sized copy twice every week during the heavy part of the season and my ads bring results.

If I can't sell a customer in the store, I always get his name and give it over to an outside salesman.

I have two high-class salesmen who follow store leads. These men have a regular territory and keep an accurate card record on their calls. Sometimes a card will have 15 notations before the sale. Persistence!

I know my outside salesmen are responsible for two thirds

of my business and I pay them an attractive commission. Good salesmen earn good money with me.

—WESLEY F. EWINGER, John Ewinger Company, Burlington, Iowa.

Increasing Service Efficiency

WHENEVER WE go on a service or repair call we make it a point to suggest to the owner the purchase of various accessories that may be advantageously employed with his receiver. We also point out that we will gladly demonstrate any accessories without cost.

As our minimum service charge is \$2, and as the average service call takes no longer than about fifteen minutes we find that it pays us to have the serviceman spend the balance of the hour that is fully paid for by the service fee in an attempt to sell the customer whatever accessories he or she can use to good advantage.

In this manner even if we do not make a sale we have the customer himself pay for the time spent for demonstration purposes; this eliminates unpaid for time and fifty per cent. of all attempts result in sales of accessories.

—BORIS S. NAIMARK, The Riverside Auto Supply & Radio Company, New York, N. Y.

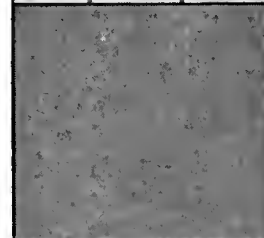
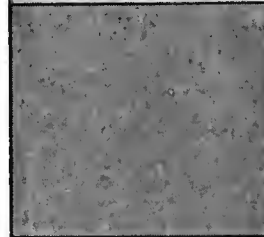

HOW ABOUT TIME PAYMENTS?

Not many weeks ago RADIO BROADCAST sent out a questionnaire to 500 radio dealers. These dealers were chosen at random but with sufficient care to insure that they represented all types of outlets handling radio. It should be understood that no effort was made to secure answers from a majority of the 38,000 radio outlets in the United States, and that the replies tabulated on these pages are not offered as conclusive or final. However, we considered the results of interest and asked Howard W. Dickinson, a nationally known merchandising consultant, to analyze and comment on the survey. He says:

TO ME THE questionnaire recently sent out by RADIO BROADCAST to 500 radio dealers has brought forth very interesting results. They are "Straws which show how the wind blows," if you will. These straws indicate quite a variable wind with reference to trade practices.

The value of an investigation of this type lies not so much in the determination of facts as in the chance it gives each dealer to ask himself, "Should I do this, or that, and Why." So, Mr. Dealer, please do not look for the statement of positive laws of action and do not be surprised if this comment on the questionnaire resolves itself into some more questions which are for you to answer.

How Sales Are Financed

The first question in the letter sent out by RADIO BROADCAST asked: "How do you finance time payments? Carry them yourself, or through a finance corporation or banker?" Dealers answered this question in three different ways: (a) 32 per cent. finance their own sales; (b) 43 per cent. finance through a bank or finance corporation; and (c) 25 per cent. do it both ways.

Shall we conclude from the above that the (a) and (c) groups are more heavily financed for each unit of turn-over than group (b)? Could it mean that the (b) group has established better credit for securing the help of outside capital than the (a) group? Or, does it mean that the (a) group adds somewhat to its book profit by saving the cost of securing outside capital? This latter might easily be an expensive saving, if it ties up the capital which should go into advertising.



It is interesting to see that more than two thirds of those who reported on this question get some outside capital to help in financing time payments—evidently this is the predominant trade habit. Shouldn't almost everybody do it, particularly the great majority, who give themselves less promotion than their business needs?

I got quite a shock from the answers to the next question—"Are you insured against defaults in time payments?" Only 8.5 per cent. of the dealers answered "Yes" and 91.5 per cent. answered "No"!

Insurance is relatively cheap. Chattel mortgages are not expensive, and I am inclined to believe that only a man with a lot of money can afford to carry his own insurance himself. Do the answers to this question indicate a deplorable lack of financial self-protection in the radio business? Is it not true that whenever general business conditions grow worse for a time, credit risks on installments show an even greater tendency to increase? Possibly different dealers interpreted the word "insurance" differently.

Interest Charged

Now comes the question which intrigued me greatly as it was bound to show a variation of considerable range—"What interest do you add to price?"

One dealer out of every fourteen—7 per cent.—does not charge interest to cover time-payment financing. I wonder why. It has become a pretty common practice and an obviously reasonable one in all kinds of installment selling.

Let us see what the rest of the dealers charge for financing: 2.8 per cent. ask 5 per cent. interest (This is generally less than cost); 14 per cent. charge 6 per cent. interest—obviously an attempt to split even on this item; 15.2 per cent. get 7 per cent. interest; 19.3 per cent. charge 8 per cent. interest; 5.4 per cent. ask for 9 per cent. interest; and 16.6 per cent.—one sixth of the dealers—charge 10 per cent. interest. In addition a few dealers—2.8 per cent.—charge 12 per cent. interest and 14 per cent. of the dealers charge 1 per cent. interest per month. Another plan which is followed by a few dealers—2.8 per cent.—is to charge \$1.00 per month, which might be a low rate or a high rate according to the volume of the sale.

These answers show that there is ample precedent for making deferred payments return an interest charge, and it is perfectly proper that they should. Isn't 10 per cent. a very reasonable and proper charge to make for financing?



FALDON

The answers to the next question—"Do you charge a uniform down payment?"—show that a majority of the dealers want to know what it means in cash to make an installment sale: 71 per cent. answered "Yes" and 29 per cent. said "No."

Isn't there a supersensitiveness to what the customer thinks he wants in those "No" answers? Shouldn't the customer recognize the dealer's need of exact methods in this particular? I believe that he can easily be made to, and the 71 per cent. seem to have put that belief into practice.

Down Payment Required

Here we come to another wide variation. I confess it surprises me to learn that as many as 48 per cent. of these dealers get one fourth of the price or better as a down payment. Obviously, it can be done. Isn't it also obvious that it should be done?

Here is the tabulation: 12 per cent. of dealers say 10 per cent. down. 12 per cent. say 15 per cent. down. 27 per cent. say 20 per cent. down, 23 per cent. say 25 per cent. down, and 16 per cent. say 33 per cent. down. So we see that 68 per cent. get one fifth down or better.

What we get and what we want are often different. The next question is: "Do you want higher down payments?" To this 68 per cent. answer "Yes" and 32 per cent. answer "No." Does not the preceding tabulation indicate that those who want larger down payments can get them? Obviously others have.

Queer how the percentages in the next question—"Do customers want lower down payments?"—almost reverse those in the last. In replying to this 61 per cent. answer "Yes" and 39 per cent. answer "No." Obviously, again, customers do not want lower down payments badly enough to prevent their buying sets.

Percentage of Cash Sales

The need for insuring against defaults in installment payment and for collecting sufficient interest is shown in the answers to the question, "What proportion of your sales are cash?" About half report that 10 per cent. or less of their sales are for cash. Obviously it takes a fairly good financier to be in the radio business if half do business with only 10 per cent. or less of cash sales.

Here is the story: 21 per cent. report cash sales of 2 to 5
(Concluded on page 122)

(1) FINANCING

- (A) How Dealers Finance Time-Payment Sales.
 - (1) Store finances sale—32 per cent.
 - (2) Through finance company or bank—43 per cent.
 - (3) Partly through bank or finance company and their own store—25 per cent.

(2) DOWN PAYMENTS

- (A) Is Uniform Down Payment Required?
 - (1) Dealers requiring uniform down payment—71 per cent.
 - (2) Dealers not requiring uniform down payment—29 per cent.
- (B) How Large a Down Payment Is Required?

(1) Per Cent. of Sale Required as Down Payment	Dealers Reporting
10	12.0%
15	12.0%
20	27.0%
25	23.0%
33	16.0%

- (C) Do Dealers Want Higher Down Payments?
 - (1) Dealers answering yes—68 per cent.
 - (2) Dealers answering no—32 per cent.
- (D) Do Customers Want Lower Down Payments?
 - (1) Dealers answering yes—61 per cent.
 - (2) Dealers answering no—39 per cent.

(3) INTEREST CHARGES

- (A) What Interest Charges Are Asked?

(1) Interest Charge	Dealers Reporting
None	7.0%
5%	2.8%
6%	14.0%
7%	15.2%
8%	19.3%
9%	5.4%
10%	16.6%
12%	2.8%
1% per month	14.0%
\$1 per month	2.8%

(4) BAD DEBTS

- (A) What Proportion of Sales Are Bad Debts?

(1) Per Cent. of Bad Debts	Dealers Reporting
None	29.0%
1 or less	38.0%
2	13.0%
3	6.5%
5	11.0%
10	2.5%

- (B) Are Dealers Insured Against Defaults?
 - (1) Dealers carrying insurance—8.5 per cent.
 - (2) Dealers not carrying insurance—91.5 per cent.
- (C) How Are Dealers Insured Against Defaults?
 - (1) Commercial credit company—1.4 per cent.
 - (2) Lease—1.4 per cent.
 - (3) Chattel mortgage—2.8 per cent.
 - (4) Insurance policy—1.4 per cent.
 - (5) Mortgage—1.4 per cent.

(5) CASH SALES

- (A) What Proportion of Set Sales Are Cash?

Per Cent. of Cash Sales	Dealers Reporting
2 to 5	21.0%
5 to 10	38.0%
10 to 20	16.0%
20 to 30	8.5%
30 to 50	11.0%
80 and over	4.0%

- (B) Are Cash Sales Larger Than Last Year?
 - (1) Dealers answering yes—30 per cent.
 - (2) Dealers answering no—70 per cent.



PROFESSIONALLY



SPEAKING

REGARDING STYLE CHANGES

THERE ARE PEOPLE who never cease comparing the radio industry with the automotive industry, the phonograph industry, or some other industry which has had its days of youth, adolescence, and maturity. In general we decry such comparisons, but in particular we must admit there are certain similarities.

Automobiles are sold to-day on two legitimate appeals, that of style, and that of technical advance. It is difficult to estimate how many of the style changes in the automotive industry are dependent upon technical advance, but it is certain that they were not made possible by engineering changes to the extent that they are in radio. It is necessary only to think over the style changes in radio to estimate how many were dependent upon radio engineers and not style engineers. Single dial sets, consoles with radio, loud speaker and power supply in one cabinet, freedom from a multiplicity of knobs and accessories brought about by the development of automatic volume control, disappearance of regenerative sets, invention of uniform gain circuits, production of a.c. tubes, change of panel effect by automatic tuning or remote control, and development of drum dials—all have been made possible by technical advance.

It seems probable that the future will find radios sold as much on style change as on technical advance. It seems advisable, then, to divorce style engineering from circuit design, and to remove from the hard-working radio engineer one of the worries that lingers in the back of his head.

A RADIO FOR THE FARMER

AFTER NEGLECTING the farm market for several years—although everyone admits the rural dweller has the most to benefit from radio—it appears that the farmer is to be subjected to the selling pressure of many if not most of the receiver manufacturers now competing for the a.c. business.

It is to be hoped that the sets made purely for the listener unable to enjoy the privilege of drawing power from house wires will not only operate from batteries and pull-in the desired stations but that they will also be inexpensive in first cost and economical in maintenance. Those not blessed with power circuits can now enjoy radio by means of battery-operated receivers and have been able to do so for a number of years. What they cannot enjoy is lugging the battery to town to be charged, and the continual drain on B batteries. They do not want just another battery set; they want a set that is engineered with their particular problem in mind, a set that operates for a month from a single battery charge and which

consumes only one set of B batteries a year instead of two or three.

A set for the rural dweller should have about four tubes, probably three screen-grid tubes and a power tube. These screen-grid tubes should have better filaments than those now obtainable. They should last longer and be less microphonic. The power tube should be similar to the pentodes now being used extensively on the Continent. They are more efficient than any American power tube, both from the standpoint of the amplification necessary to produce a given amount of power output, and from the standpoint of battery power consumption. In other words, they make possible a set which costs less to maintain as well as less in first cost.

At present it is possible to buy a radio set for less than \$60, which is probably near the rock-bottom price with present methods of distribution. There is little to be hoped for in the direction of lower first cost, apparently.

One tube manufacturer (De Forest) has announced a d.c. screen-grid tube that is sturdier than those ordinarily obtainable. It has an oxide-coated filament and heavier construction. Of eight tube manufacturers interviewed at the New York Radio Show, only one had heard of pentode tubes and the majority of the others were disinterested. Apparently there are more pressing problems in the average tube plant than developing new tubes. Or is it true that most tube manufacturers are still willing to let someone else pay the development cost?

FOREIGN VIEWS ON ADVERTISING

WIRELESS WORLD, an English radio publication, reports a decision of the Spanish government relative to radio advertising. Broadcast advertisements are stated to have killed enthusiasm for wireless and the State decree has stipulated that not over one hundred words of advertising per hour can be put on the air from a given station. This would be a severe handicap to some announcers and some advertisers in the United States. Some of the advertisements sound like a weather report transmitted at ten words per minute for North and South Polar regions and all intervening territories.

Another English paper laments the fact that radio programs in England, under the control of the B.B.C., a monopoly doled out by the government, do not compare with those of other nations where someone besides the listeners pay the bills. Particularly envious glances are directed toward the United States where the best musical and other talent is on the air through the sponsorship of national advertisers. It might be worth while to send to England those who orate most enthusiastically against our present broadcasting structure.



Please Note—

What will sell radios in the future?

Let's divorce style engineering from radio circuit design.

The farmer—a new factor in selling radio.

How the Spanish government controls broadcast advertising.

CREW MANAGERS COMMISSION RECORD										
DEALER		CREW MANAGER							WEEK ENDING	
DATE	NAME AND ADDRESS	MAKE	MODEL	SERIAL No.	SALESMAN	AMT. SALE	ALLOWANCE	NET SALE	COMMISSION	MISCELLANEOUS INFORMATION
DAILY REPORT OF NEW INSTALLATIONS										
DEALER		CREW MANAGER							DATE	
NAME AND ADDRESS	MAKE	MODEL	SERIAL No.	SALESMAN	AMT. SALE	INSPECTOR	MISCELLANEOUS INFORMATION			
DAILY REPORT OF RETURNS										
DEALER		CREW MANAGER							DATE	
NAME AND ADDRESS	MAKE	MODEL	SERIAL No.	SALESMAN	AMT. SALE	REASON FOR RETURNING				
DAILY REPORT OF UNCLOSED BUSINESS										
DEALER		CREW MANAGER							DATE	
NAME AND ADDRESS	MAKE	MODEL	SERIAL No.	SALESMAN	AMT. SALE	ALLOWANCE	NET SALE	MISCELLANEOUS INFORMATION		

House to House Selling Is NOT a Sideline

By BAYARD B. PENROSE

HOUSE-TO-HOUSE selling, in the opinion of R. B. Green, radio sales manager for Parks & Hull, Inc., wholesalers of Baltimore, Maryland, should be done right or it had better not be done at all. In other words, if you do not have the time and inclination to take it in all seriousness and devote real thought and effort to selecting and training men, the profit side of your ledger will probably show a heavier balance if you do not bother with it. Properly handled, the door-to-door man can be made a valuable adjunct to the business. Considered merely as a sideline, he may become a decided detriment.

Mr. Green's Experiments

A survey of radio conditions in Baltimore would indicate that as many and perhaps more sets are sold here per capita by house-to-house methods than in any other city. Much of this activity has been inspired by Mr. Green who has helped dealers to use his home city as something of a "proving ground" for his ideas along this line. That they have proved successful is evinced by the success of individual dealers who have followed suggestions emanating from his office.

There are a lot of things for the average dealer to learn about this method of selling. He cannot hope to make a success of it merely by hiring men haphazardly and turning them loose on the assumption that it is costing him nothing until they actually produce sales. This has been tried frequently with inevitable failure as the result.

"A lot of dealers," says Mr. Green, "have literally been stampeded into outside selling. Suddenly realizing that everything from shoes to ships and sealing wax is being sold in this manner, they have come to fear for their own futures unless they immediately adopted the method. To many, it looked easy; all they had to do was put in a want advertisement,

- Don't Do It If You Don't Do It Right*
- Don't Hire Canvassers Haphazardly*
- Weave This Branch of Selling Into Your Business*
- Supervise It Constantly*
- Pay Your Men Well*
- Control Your Stock Carefully*
- Do Fifty Per Cent. of Your Demonstrations Result in Sales?*
- Give Crew Manager a Small Salary Plus a Commission*

select a few men, and turn them loose. I don't have to tell you what usually happened. A few learned from costly experience and finally got into the swing of things when they gave this phase of their business the attention it deserved. Others failed dismally, gave up outside selling in disgust, and continued as before."

Green's Service to Dealers

With this in mind, one of the first things Mr. Green did was to put a man in charge of an outdoor selling department to be conducted both as an experimental station and as a service to local dealers. Methods were studied and tested through dealers who cooperated. Then, when the time came, leading dealers were "sold" on the proposition and urged to sponsor outdoor selling crews to be selected and trained for them by Parks & Hull. In several cases, these crews remained under supervision of the wholesale house for several weeks after going into operation. Our story, however, deals not so much

with these facts as with the general observations Mr. Green has thus been enabled to make with regard to door-to-door selling on a city-wide scale.

As indicated at the start, he has found that, above all, this phase of radio merchandising requires the closest sort of supervision. Most of those applying for a selling job of this kind are not of the highest type. Far from it. Many have made a failure in practically everything else they have tried.

Consequently, it pays to make a special effort to pick the best possible people for the work in the first place. Secondly, the proposition offered to them must have merit. There must be a reasonably good opportunity for those qualified for the work to make a fair living at it.

Next comes the training of the men and a close contacting of them by the store as a means of keeping a definite check on their activities. Among the Baltimore dealers with whom Mr. Green has worked, the training has been done by Parks & Hull but the checking up on the men has been largely up to the individual dealer.

Even with these precautions, there has been a high rate of turnover among the house-to-house salesmen—although not nearly so high as it might be otherwise. It is only necessary to compare results of dealers in other localities who have embarked upon the plan in a haphazard fashion with those in Baltimore to realize the truth of this assertion.

Personal Turnover

"After all," says Mr. Green, "this turnover among salesmen is not as bad as it might be. That is, providing the dealer keeps in close touch with them. Each salesman of fair ability has a few good sales in him. These come almost as a matter of course. Perhaps they may be made to relatives or to friends but, as far as the dealer is concerned, they are sales which probably would not come to him otherwise. As long as the dealer sees that they are not forced sales and that the salesman has not attached a lot of 'strings' to them in order to get a commission prior to his departure for parts unknown, things are not so bad.

"This is not a defensive statement for a high rate of personnel turnover. It stands to reason that the more successful salesmen the dealer can develop, the better it will be for him. I only mention it as a redeeming feature about one of the worst phases of outdoor selling."

To the dealer, outdoor selling as recommended by Mr. Green means that he will have to carry a larger stock and be reconciled to a very necessary increase in office overhead. Two crews of, say, seven men each should keep a goodly number of sets out on demonstration. Usually, it is necessary for the dealer to have from 25 to 50 or more sets on hand, depending, of course, on the extent of his proposed efforts in taking his store to the homes of prospects. These

transactions naturally require quite a little additional book-keeping, model forms having been prepared for this purpose under Mr. Green's direction. (Four of these forms are illustrated on the first page of this article.) The importance of knowing just where all sets are at all times and their exact status can hardly be over-emphasized. Yet it is a factor many dealers neglect.

Contrary to the practice of some dealers, Mr. Green urges salesmen to make as many demonstrations as they can. However, these are not made indiscriminately. The simple expedient of paying salesmen commissions ranging from 10 to 15 per cent. of the sale largely takes care of this. Similarly, dealers keep a close check on the length of time sets are allowed to remain in homes, usually limiting this to two or three days.

The fact that from 40 to 50 per cent. of demonstrations made under these conditions result in sales is, in itself, sufficient vindication of the method. Payments to salesmen run from \$25 a week to three and even four times that much in exceptional cases.

Selling Assistance

How much direct selling assistance can the dealer give to his representatives?

"Usually not a great deal," says Mr. Green. "The store can supply a few leads but the one outstanding reason for employing door-to-door crews is to get to people who cannot be reached through the regular store sales channels. It is largely up to the salesman's ingenuity to which may be coupled his preliminary training, literally to search out prospects 'where they ain't.' This requires a lot of perseverance and foot-work. If a good salesman makes enough calls, however, he'll find some prospects. Then it is up to him to turn them into customers. Meanwhile, it is up to the dealer to see that he is making enough daily calls, in addition to keeping a check on all demonstrations."

Crew Manager Receives Salary

In most instances, it has proved advisable to have salesmen work in crews under a manager who receives a small salary plus a commission on all sales produced by his men. This assures a careful, intensive working of all available territory. It likewise prevents a single salesman skimming off the cream, skipping haphazardly here and there.

Table model sets are usually used in demonstrations for convenience in handling. After the prospect has been sold on the idea of owning a radio, the selection of a cabinet is a comparatively simple matter.

"House-to-house selling does not necessarily mean high-pressure selling," says Mr. Green. "There has been too much of that attempted in the past.

(Concluded on page 122)



L. G. PACENT (Pacent): "The home talking picture field is on the threshold of a great development. Equipment for home use is perfected and all that is needed is for leading producers to supply pictures and discs."



A. A. SCHNIDERERHAHN (Schneidererhahn Co): "Women buy 65 per cent. of all radios."



FLOYD A. ALLEN (General Motors): "Too many superlatives and too much braggadocio appear in altogether too many advertisements."



GEORGE E. HULL (Parks and Hull): "Know your product! There is no better way to sell it successfully."



DR. LEE DEFORREST (DeForest): "I believe the radio industry has made tremendous strides during the past twelve months. The industry has little to worry about in the matter of market saturation."



CHARLES T. LAWSON (Day-Fan): "I feel that the kind of advertising program a dealer should put over is the kind that runs on a regular schedule throughout the year."



C. E. STEVENS (Stevens): "The electrodynamic loud speaker is here to stay. We have by no means exhausted its possibility."



ERNEST KAUER (CeCo): "If . . . the average broadcast sponsor is more intent on selling soap, tobacco, oil, or shoes than he is in the interest of the radio public, then the solution is to make the radio industry economically responsible for broadcasting's cost."

Below are pictured a group of three officials of Thomas A. Edison, Inc., and a California distributor of Edison products. From left to right they are—Alfred Hand, advertising manager, H. R. Curtiss, Los Angeles distributor for Edison, W. H. Meadcroft, secretary to Thomas A. Edison, R. B. Karch, assistant to the vice president, and A. L. Walsh, vice president and general manager.

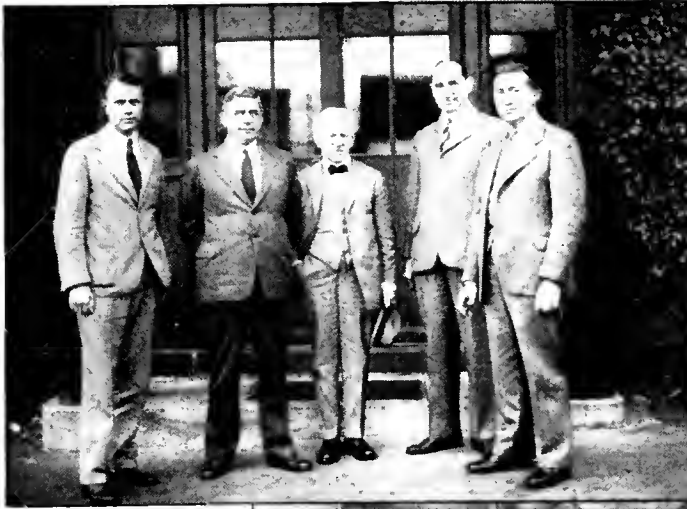

Pavel Crasley, president of the Crasley Radio Corporation has enlisted the services of several of America's foremost artists to test Crasley receiving sets in their homes and report on the fidelity of reproduction. From left to right those shown below are—George Gershwin, Alava Gluck, Efrem Zimbalist, and Pavel Crasley.

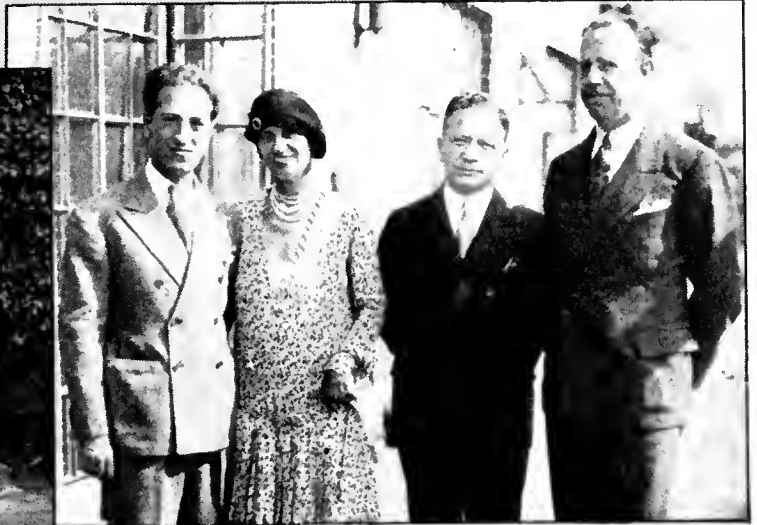

Ray Thomas, distributor for Atwater Kent in southern California, staged a radio show in the foyer of the Paramount theater in Los Angeles during the week preceding the National Radio Show in that city. This picture shows a corner of the exhibit.



Ingram Baader, seventeen-year-old student of the College of the City of New York, is shown below at the controls of the first commercial television receiver with Dr. Lee DeForest supervising him at the moment. The receiver was presented to him as the first-prize award in the Jenkins Prize Essay Contest.



Count Felix Van Luckner, the daring and gallant sea raider of war days, and now a roamer of the *Seren Seas*, receives William L. King, sales manager of the May Distributing Corporation, Philco representatives in New York, who presents him with a Philco Highboy De Luxe. This picture was taken on the Count's ship, the *Omelia*, in New York harbor.

A FEW INTERESTING RADIO PICTURES OF THE MONTH

ADVERTISE WHAT YOU HAVE TO SELL

As told by a Well-known Account Executive



LAST SUMMER two complete and different advertising campaigns were exhibited in proof form to radio jobbers and dealers throughout the country. One of these campaigns was noisy. It shrieked and yelled, roared and bellowed. Big black headlines. Superlatives. Prices hitting you in the eye. The kind of advertising you call either "cheap," or "two-fisted selling," depending on whether you like it or not. The jobbers and dealers liked it, unanimously.

The other campaign was quiet and dignified. It didn't raise its voice. Dainty, not domineering. It certainly made the reader think the Raspless Radio was a great instrument, but the amount of black ink it used wouldn't have darkened a gnat's eyelashes. Nobody liked this campaign except the manufacturer and his advertising agency, and so of course it wasn't run.

The two-fisted selling campaign went into a lot of expensive newspaper space. All bills were paid by the manufacturer, who sat back and waited for Western Union to begin delivering orders for carload lots. But the wires were silent, and even the mail carrier noticed nothing unusual. No public clamor was raised over the Raspless. In fact, the Raspless people and their agency claimed the advertising had no effect whatever, but that probably is an error. Certainly there must have been some cause of the universal decision not to buy Raspless Radios.

The Third Campaign

Swiftly—speedy folks, these advertising men!—the trade's pet choice was discarded. A third campaign, even more high hat and ritzy than the one that had been despised, was prepared. It made you think the only way to get into society was to buy a Raspless. Dignity, prestige, smartness, sophistication, and a lot of other ten-dollar words could be and were applied to it. If the reader wanted to know the price, the number of tubes, and whether they were screen grid, he had to hunt, and provide his own magnifying glass.

At the present writing this campaign is running. Western Union's business has picked up, and the mail carrier has asked for a wagon. It looks like a success.

There is a moral in this for all concerned, and here it is, in one of its 59 varieties: "Don't monkey with the other fellow's business."

A manufacturer's advertising is very much his own busi-

ness. A dealer's advertising is his own business, too. This is rather well known in other lines, but in the radio industry the acquisition of the knowledge seems to cause some of the growing pains now felt.

Fundamentally, the purpose of advertising is to sell something. Advertising will fail if it tries to sell something the advertiser cannot supply.

Often, and in fact usually, a radio manufacturer has for sale something that none of his dealers have, and each of his dealers has something that none of the other dealers have. This is true in spite of the fact that all handle an identical product, which is to be sold to the public at presumably identical prices.

What the Manufacturer Sells

This seems paradoxical. But let's list the things the manufacturer has for sale to the public—to the public, notice, and not to the jobber or dealer. Here is the list:

- 1—What his radio receiver will do for its owner—performance and appearance. This is where most of the surprisingly ineffective superlatives are spilled.
- 2—His own knowledge, skill, and experience in radio design and manufacture, and the ideals that move him.
- 3—His own reputation for (a) making good radio sets, (b) giving value for the money, (c) being up to date, (d) standing back of his products.
- 4—His reputation and standing in other fields, if any.

You will note that this list does not include Raspless Radio Receivers, for the good reason that the manufacturer does not sell them to the public. His dealers do that. The distinction is vital, and if you will contemplate the kind of advertising done by manufacturers who do sell direct to the public you will be convinced that the difference is a very real and important one.

What the Dealer Sells

For the sake of simplicity let us pass over the jobber and list what the dealer has for sale:

- 1—Raspless Radio Receivers—at last!
- 2—Service, swift and sure.
- 3—Local reputation for (a) selling good goods, (b) charging fair prices, (c) keeping customers satisfied, (d) in general, fair dealing.

Compare these two lists, and you will find not a single item

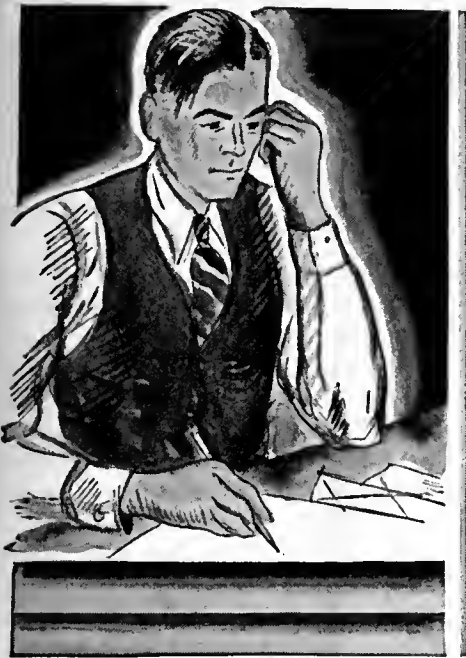

A True Story of an Advertising Campaign Which Shows that the Factory Sells Something Different from the Dealer. The Manufacturer Says, "Go Get It," and the Dealer Says, "I Have It."



in common. It is true that in selling a Raspless to a customer the dealer will repeat more or less what the manufacturer says about performance and appearance, but the dealer's attitude is "I've got a Raspless for you," while the manufacturer advises "Go get a Raspless for yourself," frequently adding a list of dealers to go to.

No, the manufacturer and dealer are two different people, and they have two different stories to tell, in two different manners. No dealer can know the manufacturer's story well enough to tell it, nor even to say how it should be told. If the dealer acts as a guide he but leads the manufacturer astray along the paths of retail advertising. And conversely, the manufacturer will lead the dealer up the wrong advertising alley if he gets a chance.

Hundreds of thousands of dollars have been wasted this year and more probably will be thrown away next year on the preparation of so-called "dealer advertising." You know—the ready-made stuff that comes to you in the form of a big book of proofs. Each advertisement has at the bottom a blank space (usually too small) bearing the hopeful words "Dealer's signature here." Just outside the border of each advertisement is a number something like this: "AX37—420li—10" X 3 cols." You can't remember this number long enough to copy it down but you are supposed to write it on an order blank.

You Write Your Own

All the advertisements are too big, the prices are wrong, and you don't like the text, somehow. So you decide not to use the ready-made stuff, and quite right you are, too. You order one electrotype of the receiver, and sit down to write your own advertisement. When you get through it is your advertisement. It expresses you and your establishment. You may not be conscious of it, but it reveals the kind of person you are, the kind of shop you run, and attracts the kind of people who would like to deal with you and with whom you would like to and can do business.

How can an advertising man who never saw you write such an advertisement for you? How can factory-made advertising do a job for you, for Bill Jones over on Commercial Street, for John Smith in the next county, and for Jim Brown in the neighboring state? It can't, and you recognize it when you reject the advice of the manufacturer, throw away the ex-

pensive book of ready-made advertisements, and write your own.

Startling advertisements have been produced in this way. Some of them have been given the raucous horse laugh by so-called advertising experts who were not expert enough to look up results and find how those advertisements paid.

Sincerity Pays

There is nothing like sincerity. It is absolutely essential in advertising, which is one field where the hypocrite has a hard time of it. If you don't believe in what you advertise, your disbelief will be seen or felt or heard or tasted or realized by your readers. It's funny how those things work. Hypocrisy will show, if it is there, in even the most professional and sophisticated advertising job.

But genuine sincerity has the same revealing quality. You can't hide it, and that's a comfort. I've seen some clumsy, ungrammatical and crude letters and advertisements that just made you want to run into the store, throw your pocket-book on the counter and say, "Quick, give me some of that!"

Every once in a while every advertising man discovers that "unprofessional" advertising can be tremendously profitable, and if it causes him any astonishment he should be digging ditches. Real folks with real goods will make money selling them, and they will make the most money if they do a lot of advertising and do it themselves, getting into the advertising the genuine, honest qualities that are in themselves and their merchandise.

However, I do not mean that there is no way for a merchant to get good advertising except by doing it personally. There are plenty of fine dealers who get outside advertising help—only it is not very far outside. They employ local advertising men. Some of the bigger dealers are able to interest local advertising agencies and obtain all their highly developed facilities. Other dealers have found advertising writers in their neighborhoods, and put their advertising on a man to man basis, which is tremendously successful—if you get the right man.

I know a tailor, who, soon after his small start, made arrangements with a local writer to exchange suits for words. Neither knew it at the time, but the tailor got the services of one of the greatest advertising writers this country has

(Concluded on page 120)

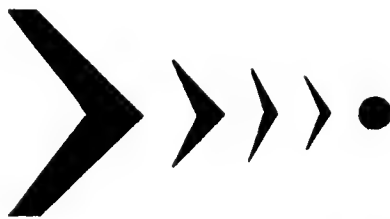

The MARCH

Why We Have Rumors of Mergers
Recent Progress Made By Broadcasting



What Is Right With Broadcasting

WE INCLINE TO stress the unfortunate development of advertising halitosis in broadcast programs in the hope of encouraging a cure. Now and then, we should pause to admit the progress which is being made in the development of constructive broadcasting programs.

We were especially pleased to observe the advertisement placed by B. J. Grigsby, of the Grigsby-Grunow Corporation, calling the attention of the general public to the growing hostility of sports promoters to radio broadcasting. Several prizefights, worthy of broadcasting, have been withheld from the air and it is understood that the last World's Series was the last to be broadcast by the leave of baseball magnates.

The sporting world may continue to cooperate with broadcasting or not as it pleases. Failure to do so will only bring about a forcible demonstration that the public support gained by broadcasting has

been of immense commercial value to sports. Sports promoters may, some day, be forced to seek the help of the microphone, now so freely presented to them. Then it will be the broadcast industry's opportunity to quote its usual rates.

In the end, broadcasting will not be denied, even if broadcasting interests must stage their own contests for the benefit of the immense radio public. This idea may seem far fetched at the moment, but there is already precedent for such a suggestion. Five years ago, the motion picture world, the stage, and the phonograph industry were fighting radio. To-day, they have become an inextricable part of it through coöperation, merger, or outright purchase. Mr. Grigsby has performed a service in calling the emphatic attention of the public to the present situation but the fact remains, whether his plea to the sports industry is successful or not, that radio has progressed to the point that it cannot be denied.

One of the bright spots in program progress is the more ambitious presentation of Damrosch's musical appreciation hours. They are a Friday morning feature, 11 to 12 Eastern Standard Time. Four courses are being conducted simultaneously for students ranging from the third grade of public school to high school and college. A 68-page manual has been prepared for teachers which is a model of comprehensiveness and practical value, enabling instructors to conduct class work closely coördinated with Dr. Damrosch's presentations. Progressive dealers will sell substantial orders to their local Boards of Education on the basis of these programs.

Another bright spot is the rapidly increasing roster of 50,000-watt broadcasting stations, of which WABC, WTAM, KNX, WLS, and KSTP are the latest additions, all of these having secured construction permits from the Federal Radio Commission during recent weeks.

To be classed as not such good news for broadcasting is the avowed purpose of WRNY, WGBS, and WCFL to upset the clear-

channel principle by seeking assignments on channels assigned exclusively to other zones. These cases are based upon the precedent established by WGY. We have gone into its effect fully in previous issues and have been pleased that, so far, the WGY decision has not seriously disturbed the peace of the allocation situation. Despite the pressure in Congress for power limitations and the destruction of the clear-channel principle, we fail to see the logic of favoring 650 localities with local services, some of them with as many as twenty, covering in the aggregate only a small part of the United States, while every part of the country might be served with six or eight programs through a geographically equalized service of powerful broadcasting stations on exclusive frequency channels.

Readjustments in the Industry

ONE REASON that so much credence is given to rumors of mergers of leading radio manufacturers is because the merger is an inevitable evolution of the industry which must sooner or later take hold on a widespread scale. The general trend in all industrial and business organization is toward merger, consummated with the objective of increasing efficiency through combination of manufacturing facilities or of sales forces or of both. Other mergers are undertaken as a means of preserving uneconomic units individually unprofitable but valuable in combination with other successful units.

The significance of mergers is best judged by the economics which they effect. Statistical analysis of mergers in all classes of industry indicates that more often than not the profits of the combined units are less than the sum of the earnings of the individual units of which they

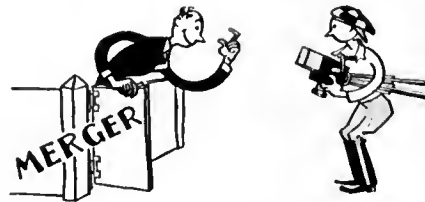

are composed. In the long run, however, bigger and more efficient businesses are built up because such mergers generally work out in practice to be the gradual discontinuance of inefficient and uneconomic units.

The radio industry is full of such units. The number of set manufacturers is excessive. The concentration of business in the hands of a few leaders is becoming more and more marked, although numerous small units still function. In the long run, ten or twelve manufacturers will do the vast bulk of the business and it would not be surprising if, within five years, four manufacturers do eighty to ninety per cent. of the total radio business. At least one of these may well be a company not now an active or outstanding factor in the field.

As the number of manufacturers narrows down, the value of the retail distribution franchise rises. Consequently, the dealer who concentrates on lines which will be a permanent factor in the industry, selected because of a long established record of leadership or because of outstanding engineering and sales ability manifested by an up and coming concern, is laying the basis for a permanent and valuable sales franchise.

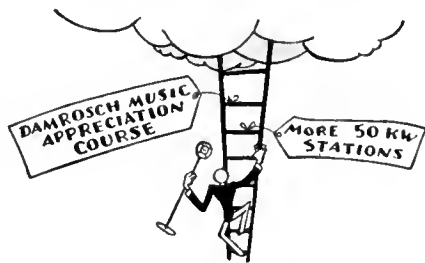

OF RADIO

Let's Kill Putrid Announcements
A Few Pointers from the Auto Industry

An influence which has prevented consummation of the large number of mergers rumored is the personal pride attached to names of leaders in the industry. A man who has built up a business around his name is not likely to surrender it to form an unidentified unit of a group. But the inevitable must be faced sooner or later because the present situation of excessive number of brands leaves the field wide open to ambitious and progressive newcomers who obtain leadership by the adoption of modern business methods successful in other lines of industry.

No more obvious course lies open than a novel approach to the distribution situation. The agency plan of distribution, similar to that adopted by the automotive industry, may ultimately become the method employed by the radio industry. This will be possible when the number of outstanding names in the industry is reduced to a handful and when the unit of sale in radio becomes larger.

While there has been a decidedly marked tendency toward lower average list prices, the radio receiver may sooner than we expect be a part of a combination of devices now sold as separate units or almost wholly undeveloped from the commercial standpoint. We have described previously in these columns what, in our opinion, will be the ultimate occupation of the radio industry, the production of a home-entertainment machine which combines radio program reception, phonograph reproduction, television, home motion picture reproduction, and recording devices for preserving visual and tonal programs for later reproduction. For example, the hour selected for broadcasting of stock market or weather reports may not necessarily suit the convenience of the listener but, if he could arrange to have these reports recorded at whatever hour they are broadcast, he may later listen to the recording at his convenience.

If engineering development is able to make a practical combination of the numerous functions to which radio- and audio-frequency amplifiers can be put in the home, the outcome will be a relatively expensive device suited to agency distribution. Hence we need look not only to the radio industry itself for logical mergers, but to its absorption by or of units in associated industries such as motion picture cameras and projectors, phonograph recording devices, television, and still picture recording.

Roasting Will Do It

THE FULL BLOOM of the domestic market for radio receivers awaits the zenith of progress in the development of radio programs. Although motor cars cost ten times as much as radio receivers, six times as many are sold! What are the obstacles in the way of tenfolding the sales of radio sets?

Prejudice! Ancient prejudices must be removed! Radio

advertising irritants, so harmful to digestion and disposition, must give way to American progress! Broadcast programs must be made safe so that women, children, and even infants can enjoy them without irritation! American intelligence will force the removal of poisonous advertising announcements, spelled p-u-t-r-i-d, which are holding back thousands upon thousands from joining the great American radio family.

Roasting will do it! Roasting the greedy advertiser at every turn, by letter to broadcasting stations, to sponsors, to newspaper and magazine editors, and to dealer outlets, until his blood is boiling in a carefully regulated oven. Roasting will free radio of putrid programs. Whoever you are, listener, dealer, manufacturer, reach for your bitterest Sucky Pipe take a mean swallow, and write your honest opinion of the sponsors who exceed the bounds of propriety. Do your bit to check the verbose and tedious advertising announcements which are holding back the growth of the radio family and reducing the hours radio receivers are being used in every intelligent American home!

In Spain a government regulation prohibits stations from broadcasting more than 100 words of advertising per hour. We hope that American advertisers will learn how to govern themselves properly before a similar regulation becomes necessary in this country.

A Lesson for the Radio Industry

A LEAF FROM the page of the experience of the automobile industry may well be adopted by radio, especially if the former becomes a factor in radio receiver distribution. Motor car manufacturers take their dealers into their confidence. They assure the stability of their market by giving the dealer definite warning of changes in models and giving him full opportunity to unload. The automobile manufacturer shares some of the losses occasioned by the introduction of new models by paying a bonus based on the number of cars sold and in other ways. Few automobile dealers have old models two or three months after the introduction of new models. Another item of sales policy which the decentralized radio industry cannot yet adopt is the automotive industry's method of assigning definite sales quotas to definite territories, thus eliminating order takers from automotive distribution. Also, one need hardly do more than privately whisper an expression of dissatisfaction with one's motor car to bring about visits from half a dozen dealers representing as many makes in a given territory. The radio dealer is still waiting behind his counter for the purchaser to come in and lay down his money. If a receiver distribution franchise were valuable, the dealer would have incentive to reach his quota and this could be accomplished only by going aggressively after business.—E. H. F.

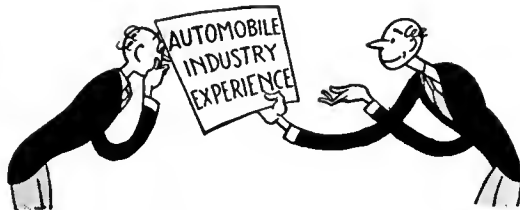

RADIO

RCA-VICTOR CORP. ENTERS THE FIELD

New Company Formed to Manufacture and Sell All RCA Home-Entertainment Apparatus

Effective January 1, 1930, all radio material in the home-entertainment field previously sold under RCA's name will be manufactured as well as sold by the RCA-Victor Corporation. Included in the new arrangements between Radio Corporation, General Electric, and Westinghouse, are radio sets, talking machines, records, and other devices in the home-entertainment field. This represents a new step in the activities of the enlarged program of the RCA subsidiaries. The 20 per cent. manufacturing profit retained by General Electric and Westinghouse in the making of radio units exclusively sold by RCA will be removed and the new organization called the RCA-Victor Corporation will encompass the research, engineering, manufacturing, and selling activities which have hitherto been distributed among the constituent companies.

The new company will be headed by E. E. Shumaker, now president of the Victor Talking Machine Company. Other officers are: J. L. Ray, H. C. Grubbs, and Alfred Weiland, vice presidents. Mr. Ray is at present in charge of all selling activities of Radio-Victor. Mr. Grubbs is a vice president of Radio-Victor in charge of the Victor Talking Machine Division, while Mr. Weiland, formerly vice president in charge of production for Victor, will have charge of all manufacturing activities. The engineering department will be headed by W. R. G. Baker, at present with General Electric.

In a joint announcement by the heads of RCA, General Electric, and Westinghouse it was said: "Of major importance is the unification of the radio research and engineering facilities of General Electric, Westinghouse, RCA, and Victor so that the same staffs which have produced so many of the major contributions to science and engineering in radio and the entire home-entertainment field will not only cooperate in the future but will actually be consolidated under a single unified direction. The new company will continue, however, to get full benefit in its field of the broad research facilities of General Electric and Westinghouse."

Executive and sales headquarters of the RCA-Victor Corporation will be in New York, probably in the new building which is to be erected by RCA at Lexington Avenue and 51st street in the near future. Fifty per cent. of the stock in the new company will be owned by RCA—the holding company for all the radio group—30 per cent. by General Electric, and 20 per cent. by Westinghouse. Present sales of the constituent units of the new company total more than \$50,000,000 annually. The Camden plant of Radio-Victor now employs more than 13,000.



General view of the plant of the Victor Talking Machine Division of the Radio-Victor Corporation of America.

The merger may increase this number to 19,000.

Speculation in the industry is now centering around the probable moves of General Electric, Westinghouse, and Western Electric. Will the radio plants of these companies continue to make sets and appliances, to be sold under the well-known trademarks of each, in open competition with the products of the new RCA-Victor corporation? Will Western Electric enter the retail field with a line of tubes and super-heterodynes? One well-

known figure in radio who would not be quoted remarked that in his opinion another twelvemonth would see separate radio sets (in each of which the Radio Group has strong financial interest) made and marketed by the following: General Electric, Westinghouse, Western Electric, RCA-Victor, and General Motors Radio Corporation. "This new step on RCA's part will enable them to make more sets at a lower price and get them on the market quicker than ever before," remarked one radio observer.

Atwater Kent Not Contemplating Merger

Over the signature of A. Atwater Kent, the following statement is made regarding the rumors that the Atwater Kent Manufacturing Company was considering a merger with other prominent radio set manufacturers.

"Varied rumors would seem to be afloat that I am contemplating a merger with one, or another, or several radio manufacturing concerns.

"Once and for all, I wish to state that there is absolutely no basis whatsoever for such reports. I have conducted my own business for more than twenty-seven years and I contemplate no change in my policy.

"I am getting a lot of enjoyment from personally directing our constantly increasing force, which now numbers many thousands, both in our plant and in the field.

"I have no idea of either dividing the direction of my business or the responsibilities which it involves."

Radio Trade-in Values

A compilation of trade-in values of radio receivers has been made by *Western Music and Radio Trades Journal*. The trade-in values are determined from answers to a questionnaire sent to Western dealers and jobbers. These trade-in values have been printed in loose-leaf form and can be obtained for \$5.00, the price including corrections for one year and one year's subscription to the journal.

Stromberg To Make Aircraft Radio Sets

The Stromberg-Carlson Telephone Manufacturing Company has made a special arrangement with the A. T. & T. Co. and R.C.A. to manufacture and sell radio receivers for the Aircraft Radio Corporation, Boonton, N. J., for the reception of beacon signals, weather reports, etc.

Television Broadcasting

The Freed Eisemann Radio Corporation will broadcast regular television programs from their short-wave station, w2xcr, located at the Allwood, N. J., plant of the Corporation. Transmission will take place on 2000-2100 kc. and 2850-2980 kc.

Arcturus Increases Advertising

According to a recent report from J. Geartner, advertising manager, the Arcturus Radio Tube Company has increased its newspaper advertising from 185 newspapers in 164 cities to 413 newspapers in 357 cities.

Cloth Diaphragms Patented

A patent on making loud speaker diaphragms of fabric has been granted to the Steven Manufacturing Corporation, according to the statement of Clifford E. Stevens, treasurer and chief engineer of the organization.

INDUSTRY

Alexanderson Patent Upheld

According to the Radio Corporation of America, a decision has been handed down by the Privy Council, the highest appellate tribunal in the British Empire, upholding the Alexanderson tuned-radio-frequency patent as against the Schloemilch and Von Bronk patent.

The case went to the Privy Council in London on appeal from the decision of the Supreme Court in Canada. In the Canadian litigation, the Alexanderson patent was sustained by the lower court, this decision was reversed by the Supreme Court of Canada, and after much controversy it was taken by the Privy Council in England.

The two patents had already been considered by two Federal District Courts of the United States both of which had decided in favor of the Alexanderson patent.

R.M.A. Credit Service Expanded

Leslie F. Muter, chairman of the R.M.A. Credit Committee, announced that the Association's credit and collection service is to be expanded in an effort to reduce further the credit losses of its members. These losses amount to several million dollars annually, according to the Committee.

Weekly bulletins giving complete credit and collection information in confidence are exchanged between the radio manufacturers through the central office of the Radio Manufacturers' Association, and frequent meetings of the various regional credit committees of the R.M.A. are held. By centralizing collections, employment by manufacturers of individual attorneys is avoided with consequent economy in the collection of claims.

New Radio for Chrysler Car

Automobiles manufactured by the Chrysler Corporation will be equipped with a special radio receiving set through an arrangement made with the Transitone Company, in which Chrysler has acquired an interest.

Personal Notes

Vernon W. Callamore, Atwater Kent sales manager, left New York on September 28 for a three-month vacation in Europe.

Otto Paschkes, president of the Polymet Manufacturing Corporation, sailed on the Bremen on October 4 for an extended tour of the Continent.

W. D. Powers has recently joined the CoCo Manufacturing Company, Inc., as merchandise manager, taking on some of the work formerly in the hands of the advertising and sales departments. Mr. Powers was sales manager of the Providence Company.

W. A. Brooks has just been appointed assistant to Alfred Marchehev, president and general manager of the Temple Corporation. He will assume part of the responsibility now on Mr. Marchehev's shoulders.

J. B. MacQueen is now a special representative for the Crosley Radio Corporation in the Arkansas territory. His headquarters will be at Little Rock.

Taylor C. White is the manager of the Seattle Branch of the Edison Distributing Corporation. He covers Washington, Oregon, and Idaho.

F. Clifford Estey, who has the distinction of being the first radio sales manager in the United States, has been made assistant to A. R. Hill, president of the United Reproducers Corporation. Mr. Estey was formerly assistant to the president of Crosley Radio Corporation and for the last few months has served as radio counsel for the Geyer Advertising Company, Dayton, Ohio.

Otto Schairer, formerly in the patent department of the Westinghouse Electric and Manufacturing Company, succeeds Captain Howard Angus as director of patent developments of the Radio Corporation of America. He has also taken over the responsibility of the R. C. A. licenses.

Morris S. Owens has been appointed field supervisor by Gross Brennan Inc. He will contact the entire New York and New England territories for Stromberg-Carlson. Mr. Owens entered the talking machine field in 1910 with the New York Talking Machine Company. He later owned several stores in Brooklyn.

At a recent meeting of the Board of Directors of Electrad, Inc. Henry G. Richter was elected vice president in charge of engineering, and Edward Metzger, vice president and general manager in charge of credits, general office and factory supervision.

Alfred Snehoff has joined the Chas. Freshman Radio Stores, Inc. He will serve in the capacity of general sales manager with complete jurisdiction over the entire chain of 12 stores.

F. J. Bullivant has been appointed sales manager of the Trav-Ler Manufacturing Corporation. Mr. Bullivant in assuming his new duties will retain

Rola Wins Over Lektophone

The Circuit Court of Appeals for the ninth circuit has affirmed the decision of the United States District Court for the northern district of California, southern division, which was to the effect that the Rola Company did not infringe the patents of the Lektophone Corporation in the design and construction of their loud speaker.

The Southwest Radio Show

The Fifth Annual Southwest National Radio Show was held in St. Louis during the latter part of September. There were 52 exhibits of which 46 were radio manufacturers. The jobbers in the St. Louis territory paid for eighty per cent. of the booth space and ninety-six per cent. of the decorating expense. The average daily attendance was 20,000. The maximum attendance for any single night was 26,954. From figures gathered it was estimated that over \$750,000 worth of business was transacted consisting largely of set sales by jobbers to dealers.

British Branch of R.F.L.

L. M. Hull, vice president of Radio Frequency Laboratories, Inc., Boonton, N. J., has just returned from England where he established a sister laboratory to the R.F.L. The English company will be called Radio Frequency Laboratories, Ltd. It is planned to have an all-British technical personnel which will work in close cooperation with the American laboratories.

Herbert E. Fenner, general service manager of the American Bosch Magneto Corporation at Springfield, Mass., sailed for South America.

Henry W. Butterworth, formerly a salesman for Wilkening, Inc., Crosley-Amrad distributors, of Philadelphia, has joined the staff of announcers for wjz of the National Broadcasting Company.

Edmund O. Lesquier, general credit manager of the American Bosch Magneto Corporation and Herbert Shoemaker, Chicago sales manager, recently flew to Minneapolis. Mr. Lesquier made first-hand contacts with distributors and dealers and gained special information for Bosch Radio Better Business Bulletin No. 7.

J. W. Hitchcock has been appointed assistant sales manager, in charge of Atwater Kent distributor relationships. E. E. Rhoads has been appointed assistant sales manager in charge of Atwater Kent territory managers and senior and junior salesmen. He will direct the Atwater Kent sales organization in the field. A third new assistant sales manager is F. E. Basler, who is in charge of the home sales office.

Carl Dreher, formerly chief engineer of RCA Photophone, Inc., and for the past six months in charge of sound recording at the above company's studios in New York City, is on an extended trip to Hollywood. He is now associated with the technical side of this company's moving picture productions and will survey and technically supervise the many recording activities of RCA Photophone, Inc., in the leading West Coast studios.

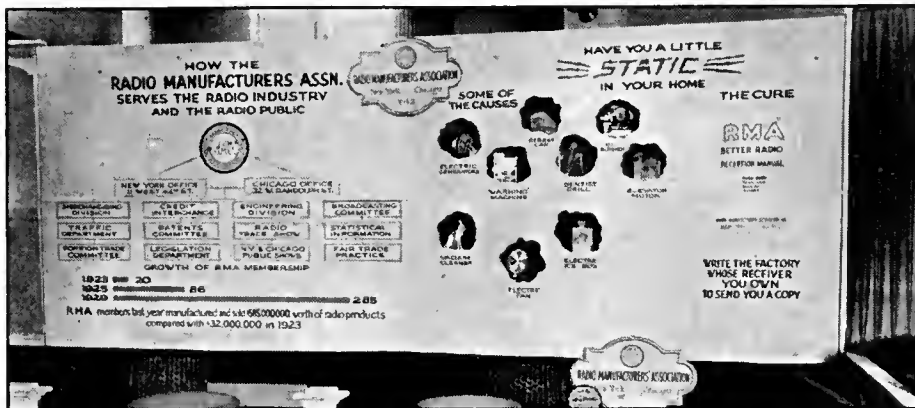

This display was used by the Radio Manufacturers' Association at the New York and Chicago radio shows to tell spectators how the association serves the radio industry and the public.

R.M.A. Working to Raise Radio Advertising Standards

Constant efforts and much progress are being made to raise the standards of radio advertising, according to Morris Metcalf, of Springfield, chairman of the Fair Trades Practice Committee of the Radio Manufacturers' Association. In coöperation with Better Business Bureaus and other organizations, Mr. Metcalf, outlining the goal of the Radio Manufacturers' Association for the best ethics in radio advertising, believes that real progress is being made not only in this endeavor, but in bettering general trade practices in the selling of radio and also in adjusting disputes between members and other interests.

"It is estimated that between \$20,000,000 and \$25,000,000 is spent annually by radio manufacturers in advertising channels," said Mr. Metcalf. "In the hectic and unstable days of the industry advertising excesses crept in, as in other new industries. This condition has largely been changed.

"The sincere personal acquaintances and friendships that result through association work tend to eliminate a good deal of sharp practice, false statements, and unfair competition among the members.

"The radio industry is peculiar in many ways, and because it deals with a newly discovered force and highly technical apparatus, the public knows very little about it and is easily misled and confused regarding radio merchandise. Therefore, there is more than the usual need for frankness and fairness in our dealings with the public, and I am glad to say that, in the main, members of the Radio Manufacturers' Association practice this policy."

An Interesting Sales Bulletin

One of the most readable and interesting sales bulletins issued by a distributor is that sent out regularly by J. H. Burke Company, 221 Columbus avenue, Boston, Atwater Kent distributors. The regular message is prepared in the form of a broadcast and carefully preserves the style of the usual other announcement. The Burke Company report that this friendly feature is very popular with their dealers.

Activities of R.M.A.

Choice of Atlantic City for the 1930 R.M.A. convention and trade show, protection of the radio industry and public against harmful radio legislation, stimulation of broadcasting features and other trade promotion, pressure of the R.M.A. patent interchange plan, and the semi-annual convention of the Engineering Division, were the highlights of the Radio Manufacturers' Association's crowded calendar which were considered by its Board of Directors and Committees at the Hotel Astor, during the week of the annual Radio World's Fair at Madison Square Garden, September 23-28.

Stimulation of new and improved broadcasting features for the radio public, including measures to insure the public reception of features of national interest, such as sporting events which some private promoters are reluctant to have broadcast, was planned. In the development of radio programs, the Association's Broadcasting Committee, headed by B. G. Erskine, in conjunction with the Merchandising Committee, will enlist the further interest of manufacturers. It will also work with the chain broadcasting interests in securing broadcasts of all the national events.

The R. M. A. Board approved the plan presented by the Legislative Committee to establish an information service in connection with all radio legislation in the states and important cities. The new information service, already organized in over half of the states, includes the appointment of state chairmen from among the ranks of radio manufacturers, jobbers, or dealers, and the organization of committees in each state to advise the R.M.A. central office of the new radio legislation which is proposed. The new information service is being organized by A. T. Haugh, of Rochester, New York, former president of the R.M.A.

The Engineering Division, headed by its director, Walter E. Holland, of Philadelphia, had two days of busy sessions with about 150 prominent radio engineers in attendance. The members of this Division had a luncheon on September 26, and in addition separate meetings of all Committees were held and well attended.

Marvin Has World-Wide Distribution Chain

The Marvin Radio Tube Corporation representing the merger of seven independent tube manufacturers, now has, according to F. A. LaBaw, general sales manager, seventy distributors appointed in the United States and in addition have representatives in England, Belgium, France, Portugal, Spain, Italy, Switzerland, Germany, Japan, China, Australia, and the Philippines. By December, 1929, the number of distributors in the United States is expected to increase to 125.

Radio in Schools

E. C. Grillin, superintendent of schools for the State of South Dakota, has launched a campaign to put a radio in every South Dakota school. In the state there are some 5000 schools.



E. O. Lesquier,
Credit Mgr.,
Bosch.

Twenty schools in various parts of the country are equipped with RCA centralized radio apparatus, according to Quinton Adams, vice president, Radio-Victor Corporation. Some sixty to seventy other schools are planning to install such apparatus soon.

Recently Issued Patents

- No. 1,730,412. High-Frequency Broadcasting Over Power Lines. Robert D. Duncan, Jr., East Orange, N. J., assignor to Wired Radio, Inc., New York, N. Y. Filed December 5, 1923.
- No. 1,730,529. Sound-Absorbent Shield for Walls of Studios and the Like. Percy A. Robbins, Highland Park, Ill. Original application filed September 14, 1927, and in Canada August 17, 1927. Divided and this application filed November 30, 1928.
- No. 1,730,611. Art of Artificial Sound Reproduction. Herman S. Heller, New York, N. Y., assignor, by mesne assignments, to Electrical Research Products, Inc. Filed October 9, 1926.
- No. 1,730,837. Cathode for Electron Emitting Devices. Frederick S. Armstrong, River Forest, Illinois, assignor to National Union Radio Corporation. Filed August 31, 1928.
- No. 1,730,878. Modulation System. Robert L. Davis, Wilkensburg, Pa., assignor to Westinghouse Electric and Manufacturing Company. Filed August 6, 1925.
- No. 1,730,903. Elimination of Disturbing Oscillations in High-Frequency Systems. Karl Schmidt, Berlin-Lichtenrade, and Walter Hahnemann, Berlin-Tempelhof, Germany, assignors to C. Lorenz Aktiengesellschaft, Berlin, Germany. Filed May 20, 1925, and in Germany, May 27, 1925.
- No. 1,730,976. Helical Drum Scanner. Charles Francis Jenkins, Washington, D. C., assignor to Jenkins Laboratories, Washington, D. C. Filed June 13, 1928.
- No. 1,730,987. Variable Band Amplifier. Frederick K. Vreeland, Montclair, N. J., assignor to Vreeland Corporation, New York, N. Y. Filed July 20, 1926.
- No. 1,730,994. Radio Frequency Amplification System. Francis J. Bullivant, St. Louis, Mo., assignor to Valley Electric Company, St. Louis, Mo. Filed November 5, 1925.
- No. 1,731,012. Radio Frequency Amplification System. Victor H. Laughter, Memphis, Tenn., assignor to Valley Electric Company, St. Louis, Mo. Filed January 16, 1924.
- No. 1,731,013. Radio Frequency Amplification System. Victor H. Laughter, St. Louis, Mo., assignor to Valley Electric Company, St. Louis, Mo. Filed November 5, 1925.
- No. 1,729,649. Program Transmission Over Wires. John F. Tootoey and Henry E. Phelps, New York, N. Y., assignors to American Telephone and Telegraph Company. Original application filed November 11, 1922. Divided and this application filed November 12, 1923.
- No. 1,729,888. Getter for Vacuum Devices. Leon McCulloch, Pittsburgh, Pa., assignor to Westinghouse Electric and Manufacturing Company. Filed October 14, 1924.
- No. 1,728,617. Method and Apparatus for Elimination of Static Disturbances. Frederick W. Kranz, Geneva, Ill., assignor to B. Cumming, trustee. Filed June 9, 1924.
- No. 1,728,755. Speaker Unit. Carl F. Goudy, Flushing, N. Y., assignor to Patent Electric Company, Inc., New York, N. Y. Filed April 19, 1928.

Old-Fashioned Tally-Ho Startled Philadelphia Business Men



Atwater Kent scored a scoop during their Salon Showing Week in Philadelphia by their novel presentation of a half-century-old tally-ho which was authentic down to the least detail. This device, embellished by several attractive signs announcing the National A.K. Cabinet week, was manned by a dandy coachman and footman, and was drawn by four prancing horses through the busy downtown streets.

Production Figures

Bosch factories have been speeded up to maximum capacity according to a statement by G. W. Stackhaus, Pacific Coast division manager of the corporation. During a six-week period 107 carloads of Bosch receivers were sold in the Pacific Coast territory.

Production of loud speakers by the Oxford Radio Corporation, formerly the Joy-Kelsey Corporation, is proceeding at the rate of 2000 a day and will shortly be increased to 4000 per day. These loud speakers are being used by Zenith, Wells-Gardner, Montgomery Ward, and others.

It is reported that set sales by the Philadelphia Storage Battery Company for the year 1929 are expected to exceed 500,000 sets with a total retail value of about \$80,000,000. These sets are distributed through 10,000 dealers and distributors located throughout the United States and Canada. The company has signed a contract with the Commercial Investment Trust, Inc. who will finance the time-payment sales. C.I.T. also handle the time-payment sales of several other manufacturers including, R.C.A. Zenith, Eveready, and Sparton.



**A. T. Murray,
President,
Bosch**

Burtex diaphragms, a product of the Stevens Manufacturing Corporation, are now being made at the rate of from 15,000 to as high as 26,000 per day. Orders on hand total not less than 385,000 diaphragms, stated Clifford E. Stevens, chief engineer. He also stated that the company had supplied approximately 650,000 diaphragms to the manufacturers of Victor radio and phonograph sets.

According to reports the DeForest Radio Corporation's September sales were 37 per cent. above August. Gold Seal has \$6,000,000 of unfilled orders. Marvin reports receiving a \$1,000,000 tube contract. U. S. Radio and Television's September sales were about \$1,500,000, current production being about 2000 sets per day. Polymet reports September sales of about \$600,000 against \$96,000 two years ago. Temple's August shipments totaled \$712,836 against \$102,202 a year ago.

New Addresses

Ted Nelson, president of Pioneer Broadcast Service, Inc., has announced the removal of his company to its new quarters in the General Motors Building, 1775 Broadway, New York City. According to Mr. Nelson approximately 50 stations in the United States and 3 stations in Canada are regularly using the recorded program service of his company.

An entire additional floor has been added to the New York plant of the Polymet Manufacturing Corporation located at 829 East 134th street. Officials of the company state that announcements will soon be made of additions to their manufacturing plants at Winsted, Conn., and Easton, Pa.

The Van Horne Tube Company has opened an office and warehouse at 108 West Lake St., Chicago. From this point all adjoining territory will be served. The new facilities will make possible 24-hour service to all the important markets of the United States.

Distributors Appointed

HY-VAC RADIO TUBE CORPORATION, 86 Shipman Street, Newark, N. J., has appointed as Pacific Coast sales representatives the James P. Hermans Company, 585 Mission St., San Francisco, Calif., and the Marshank Sales Company, 224 East 16th St., Los Angeles, Calif. W. A. Bittner, 405 Penn Ave., Pittsburgh, Pa., and the Halperin Distributing Company, 5 West 19th St., New York, have also been appointed.

STEINITE RADIO COMPANY, Fort Wayne, Indiana, announces that the Nott-Atwater Company, Spokane, Wash., have been appointed Steinite distributors in that territory.

CECO MANUFACTURING COMPANY, INC., Providence, R. I., announces the appointment of two Chicago distributors: the Sheridan Auto Supply Company, 3921 Sheridan Road, and the Siegel Electrical Supply Company, 130 North Clinton St.

VAN HORNE TUBE COMPANY, Franklin, Ohio, has recently selected several firms to represent the company. They are: R. R. Bean in the Pacific Northwest and in British Columbia; Gerber Sales Company, 94 Portland St., Boston, Mass., for the New England States; Gil Stadeker covers northern Illinois, northern Indiana, and eastern Wisconsin; The F. T. Reuter Company, Kansas City, serves the trade in Missouri, Iowa, Arkansas, Oklahoma, Texas, Louisiana, and western Tennessee; J. D. Palmerlee for the entire state of Michigan; Paul Douden, of Denver, for Wyoming and Utah, and A. W. Marshall, of Louisville, for Kentucky. Other new distributors for this company are: The Johnson Electric Supply Company, The Carobell Service Company, The Southern Ohio Radio Corporation, and the C. & D. Auto Supply & Radio Corporation. These companies are also distributors of nationally advertised radio equipment and are all located in Cincinnati, Ohio.

B. W. SMITH, INC., Cleveland distributors of Edison radios, phonographs, and records, announces a new division of this company. It is the Edi-Radio Mart, located at 622 Broadway Ave. in Cincinnati. T. R. Boring will be in charge.

THE STATES OF MAINE and New Hampshire have been added to the territory covered by Gross-Brennan, Inc., eastern district distributors of Stromberg-Carlson receivers. They now cover Metropolitan New York, New Jersey, and all of New England with the exception of Vermont.

THE FOLLOWING representatives for General Amplifiers have recently been appointed: Walter W. Boes, 622 Broadway, Cincinnati, Ohio, who will cover the territory of southern Ohio and northern Kentucky; C. J. Spencer, 29 Stewart St., Detroit, Mich., who will handle this line in and around Detroit; V. A. Hendrickson, c/o Martin-Copeland Company, 37 Maiden Lane, New York City, who will cover the territory of Metropolitan New York, Philadelphia, New Jersey, and southern Connecticut.

THE RADIO DIVISION of the Gulbransen Company, of Chicago, has appointed five new jobbers in seven of the larger distribution centers of the country: Braiterman Fedder Company, Baltimore;

Financial Notes

The regular quarterly dividend of 1 1/2 per cent. on the preferred stock of the Sparks-Withington Company was declared payable September 16th. A dividend of 25 cents per share on the new common stock, payable September 30, was also declared.

According to figures supplied by A. T. Murray, president, the American Bosch Magneto Corporation, earnings for the first six months of this year were \$1.80 a share as against 50¢ the previous year.

The Grigsby-Grunow Company and subsidiaries report a net earnings before deducting Federal taxes of \$5,679,341 for the year ending May 31, equivalent to \$13 a share on the 437,040 shares of common stock outstanding. Net profit available for common dividends after deducting taxes and non-recurring charges, amounted to \$1,915,932. Net sales for the twelve months totaled \$49,318,668, gross profits on sales being \$9,004,551. The company announced that almost 800,000 receivers were built.

George Byers and Sons Co., Columbus, Ohio; Colonial Electric Supply Company, Philadelphia; North Coast Electric Company, of Portland, Oregon, Seattle, and Tacoma, Washington; and Smith-Hassler-Storm Company, Indianapolis.

TWO ADDITIONAL distributors this year in the Hawaiian Islands bring the total list of Bosch radio distributors in the Pacific Coast Division to fourteen. The two Hawaiian distributors are Moses Stationery Co., Ltd., Hilo, T. H., and Tevos and Tevos and Joaquin Co., Ltd., Honolulu, T. H.

SPEED TUBE sales for the western district will be in the hands of C. M. McIntosh, it has been announced from the offices of Cable Radio Tube Corporation. In the southern California territory, Barrie C. Bloeden, of 1321 Maple Ave., Los Angeles, has been appointed and his company will operate under the name of Speed Sales Company. In northern California, the Monarch Sales Company, 1268 Mission St., San Francisco, has been named Speed representative. For Washington, Oregon, and Idaho, the A. S. Detsch Company, Security Bldg., Portland, has been selected. All these sales organizations and the Denver representative, the C. M. McIntosh Company, now are directly under the supervision of Mr. McIntosh.

ANNOUNCEMENT was made on October 10 of the appointment of H. M. Tower Corporation, of Boston and New Haven, as wholesale distributors of Bosch Radio in Vermont and western Massachusetts. Charles J. Parker, of Minneapolis, Minn., has opened a distributing house in that city for the distribution of Bosch Radio.

Contest Winners Receive Stromberg-Carlson Radios as Prize

Herbert A. Brennan, of Cross-Brennan, Inc., distributors of Stromberg-Carlson receivers, presents prizes to winners of a contest in which participants were asked to state in twenty words why they would like to own a Strombergset. Winners are (left to right): Frank A. Walsh, first prize; William J. C. Belbey, second prize; and Mrs. A. Kunow, third prize.



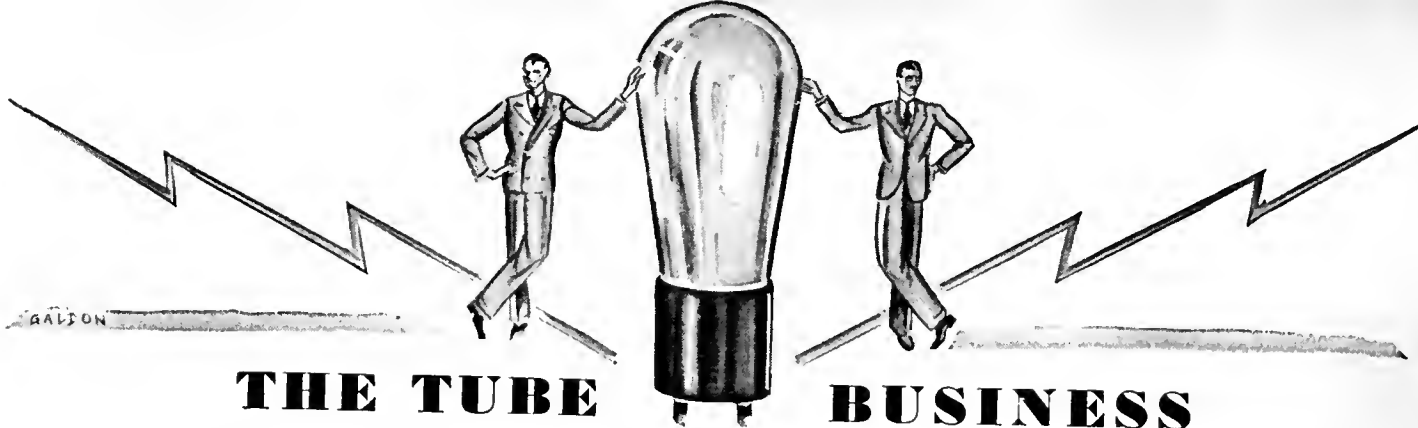

THE TUBE BUSINESS

FINANCIAL NOTES

CeCO OFFERS rights to its shareholders, one share for every five now held. For the first eight months of the year, Ken-Rad reported net earnings of \$242,471 after deducting all charges but taxes. This compares with \$123,127 for the same period of last year. Earnings are estimated to be \$4 a share for the year. CeCo's net income for September was \$88,147 after deducting charges, royalties, and taxes. Public offering is to be made of 49,000 shares of no par value stock of the Tungsten Electric Corporation. This company was organized to acquire Callite Products Co., Inc., Independent Contact Manufacturing Co., Inc., International Wire Co., Inc., and Precision Metal Products Co., manufacturers of tungsten and molybdenum products for the electrical equipment industry.

The National Union Radio Corporation has acquired the assets of the Northern Manufacturing Company, makers of Marathon and other tubes. An exchange of stock of the two companies is made on the basis of $\frac{2}{5}$ share of National Union for one share of Northern. The exchange involves 70,000 shares of Northern stock.

SALES NOTES

SEPTEMBER DEFOREST sales set an all time record, 37 per cent. above August. Gold Seal reports unfilled orders amounting to six million dollars. Marvin reports a single order for one million tubes, a contract amounting to \$800,000. Perryman sales in September were up 185 per cent. and in nine months were up 202 per cent. from one year ago. CeCo sales for August aggregated \$302,151 or 196 per cent. above one year ago. Cable's (Speed) August sales were three times as great as those for the same period last year. In September the company had orders on hand for 2,000,000 tubes.

TUBE SHORTAGE IN OHIO

IN SEPTEMBER a shortage of tubes was reported in the Cleveland district. Jobbers in the Ohio city reported they were unable to get a sufficient supply of tubes to serve their clientele.

MAKING 25,000 TUBES A DAY

SIX MARVIN PLANTS which were running at 18,000 tubes a day in October will be speeded up to 25,000 a day in November to fill contracts on hand. This is sufficient proof, according to F. A. LaBaw, sales manager of Marvin, that Marvin is following the correct policy. Manufacturers who make arrangements with set makers are likely to find themselves in hot



F. A. LaBaw

The Customer Depends on the Serviceman

BY L. P. NAYLOR

Sales Manager, Arcturus Radio Tube Co.



L. P. Naylor

MY FIRST THOUGHT in regard to the serviceman and his relation to the sale of tubes is that he is a hindrance to tube manufacturers. This does not mean that he cannot prove to be just the opposite and in even greater proportions. Perhaps this is the result of poor tube

construction and habit on the part of the serviceman.

The average serviceman makes his call with the idea that the fault is with one or more of the tubes. He believes the set is perfect because he has either tested it before the sale or because he has tested a good number of similar sets sold by his employer. He overlooks the fact that he likewise tests a large percentage of the tubes. He is too ready to believe the tube will not stand up—probably as a result of past experience with inferior tubes.

When the serviceman tells the customer that the reason for poor reception is tubes, his personal opinion, the likes and dislikes or preference for the tube of a certain manufacturer plays a big part.

If the serviceman will change his attitude and be fair with respect to present-day tubes, much will be gained.

The serviceman's intimate contact within the home of the customer places him in a position to have his actions mean more than will any other contact.

Radio set owners have a right to depend on the serviceman. What he does and says will govern the entire case.

water when "in times of stress they are confronted with binding alliances which have to receive first consideration."

VALUE OF TIME ON THE AIR

DOES TIME ON the air pay the tube manufacturer? H. H. Steinle, of the Triad Manufacturing Company, believes it does. "We believe that a considerable percentage of our present business is due largely to the reaction to our radio programs. They serve as a means of acquainting the prospective buyer with our product. The next logical step is for him to visit the dealer's store." Mr. Steinle backs up the radio advertising with aggressive newspaper advertising in the leading cities.

AVERAGE TUBE PRICES

AVERAGE RETAIL PRICES of radio tubes have decreased and then increased according to the following table prepared by

Chester Braselton, president of Arcturus. In 1922 the average price per tube was \$6; 1923 \$3.77; 1924 \$3; 1925 \$2.40; 1926 \$1.93; 1927 \$1.63; 1928 \$2.19.

PRODUCTION NOTES

THE MUNDER ELECTRICAL Co., Springfield, Mass., has increased production to 6000 tubes a day. This firm makes Vox tubes and tubes for the Radio Retailers' Ass'n. DeForest is operating two plants with a total floor space of 150,000 square feet, has over 2000 employees, and passes for shipment over 25,000 tubes a day. Cable is operating four plants which do nothing but supply raw materials for Speed tubes. The CeCo factory operates 23 hours a day; one hour in the early morning is allowed for the plant to cool off. Hy-Vac has moved into a newly purchased building in Newark. It has about 225,000 square feet of floor space. The September production aim of this company was 15,000 tubes per day. George Duff, president, Gustave Binder, vice president and treasurer, and J. Franklin Dorsey, secretary, are Hy-Vac officers.

THE NATIONAL UNION MERGER

AN OFFICIAL of one of the constituent companies making up the National Union Radio Corporation had the following to say regarding the amalgamation and what it will mean to the individual companies:

"This is not only a business merger; it is at the same time, a merger of the business brains, merchandising genius, and the engineering talents and experience of these four big organizations, together with a merger of their finances. All of the advantages accruing from this enhancement of facilities will be reflected directly in the product itself.

"Added to this are the advantages which result from the right to utilize the patents of the Radio Corporation of America, General Electric Company, and Westinghouse Electric and Manufacturing Company plus all that is implied by the two-million dollar investment by the Radio Corporation of America in the new company. It will be readily seen that the clients of the divisions of the National Union Radio Corporation are happily connected with one of the largest and most progressive units in the entire tube industry."

HARRY HOLMES RESIGNS

EFFECTIVE OCTOBER 14, Harry C. Holmes resigned as director of sales of the De Forest Radio Company after an association with the company since its reorganization in June, 1928. At the time this was written (October 20), Mr. Holmes had formed no other connection in the radio business.



H. C. Holmes

Tuned BAND-FILTER

Flat-Top, Straight-Side
10-Kilocycle Selectivity



A famous feature exclusive with Hammarlund Receivers for two years.

Gives perfect 10-kilocycle tuning, without cutting sidebands.

Reduces background noises. Improves tone.

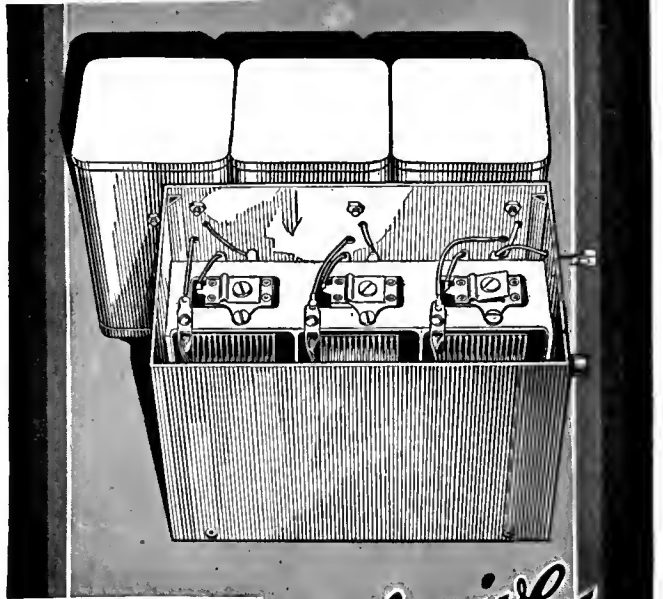

Exclusive

NEVER before, outside of special laboratory models, has there been available to radio constructors such a receiver as the new "HiQ-30."

Its extraordinary features are so far in advance of even previous "HiQ" Models that the loyal army of Hammarlund enthusiasts throughout the world will welcome the "HiQ-30" with nothing short of amazement.

A masterpiece mechanically and electrically, with extraordinary beauty as well. No miscellaneous collection of parts—but *each component specially built* for the characteristics of the circuit and everything to the last screw supplied by the factory.

Perfect selectivity—range limited only by atmospheric conditions—deafening power under velvet control—tone that thrills the music critic—one-dial operation—uses any length antenna—push-pull '45 audio amplifier—permanent phonograph connection—choice of speakers and cabinets, including phono-radio combinations.

Build the "HiQ-30" yourself or we'll recommend a local custom-radio builder to assemble it for you.

Get the "HiQ-30" story *Now*. Mail coupon for 48-page Manual—a wonderful guide book for constructors of modern receivers.

**Completely Wired
Factory-Built Units**

Including Three-Stage Tuned Band Filter—Three-Stage Tuned Screen-Grid Amplifier—Special Power Pack—Six Tuned Circuits—individually and collectively shielded.

The most flexible—the most scientifically perfect—the greatest performing radio of all time.

HAMMARLUND-ROBERTS, INC.

424-438 W. 33rd St., New York

Hammarlund
Custom-Built
RADIO



BLACKSTONE
One of nine magnificent "HiQ-30" Special Consoles available from the factory.

WINDSOR
A radio-phonograph combination of rare excellence and distinctive beauty.



MANUAL
424-438 W. 33rd St.
New York

Mail Coupon and 25c. for "HiQ-30"
HAMMARLUND-ROBERTS, INC., Dept. RB-12
Enclosed 25c (stamps or coin) for 48-page
"HiQ-30" Manual.

Name.....
Address.....

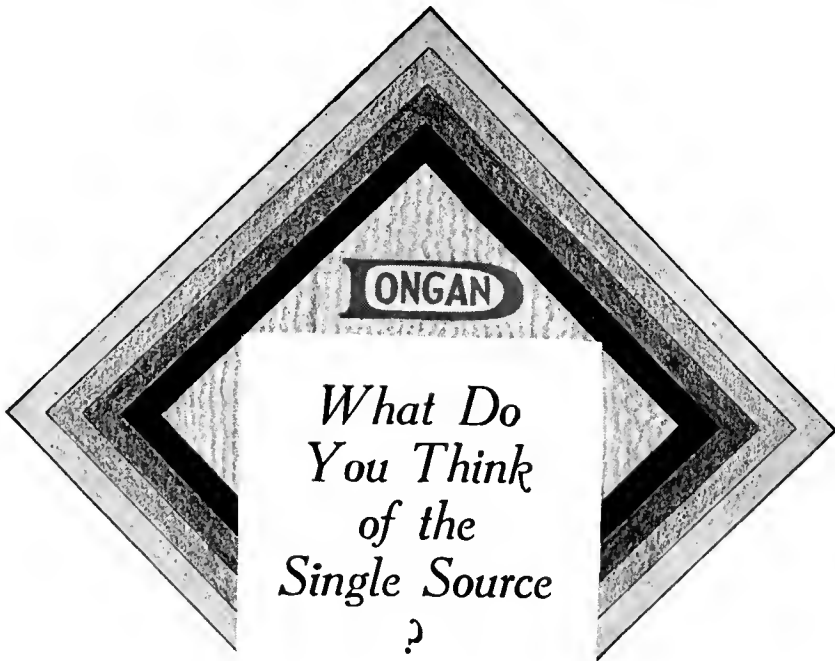

DANGEROUS? All your eggs in one basket? Or have you found from experience that, like everything else, it depends upon just who the Single Source of Supply happens to be.

Any radio manufacturer who has a season's contract with Dongan has a season's insurance—on a quality product, delivered as promised. There will be no halts, no delays in the production line, nor rejected sets nor amplifiers because of an inferior run of transformers.

Year after year the list of those whom Dongan serves as a Transformer Source, is augmented by a few more of the larger and better manufacturers. Those of you who seek such a satisfactory source for the coming season are invited to make use of our Engineering facilities for experimental work—now.

Transformers Chokes Condenser Units

Complete Parts for construction of Amplifiers for theaters, dance halls or public address systems

Dongan Electric Manufacturing Co.

2991-3001
Franklin Street



Detroit
Michigan



ON AND OFF
IN A JIFFY

Fulco RADIO COVERS



"FULCO" covers are used by those dealers who realize the importance of making deliveries in perfect condition — without scratches or mars. For they know that complaints mean dissatisfied customers and loss of business.

"FULCO" covers are a real service feature that helps sales and holds trade. Substantially constructed, heavily padded, box-shaped, providing perfect protection. Give us the dimensions of radios handled and let us quote special prices on your individual needs. Write our nearest house.

Fulton Bag & Cotton Mills

Manufacturers Since 1870
ATLANTA · NEW ORLEANS · DALLAS · ST. LOUIS
MINNEAPOLIS · BROOKLYN · KAN. CITY, KAN.

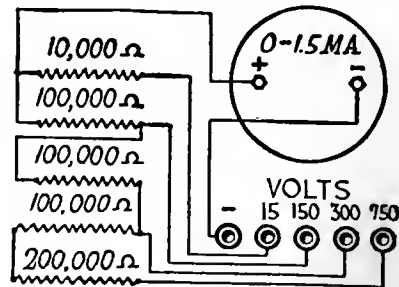

A Voltage Multiplier

The Super Akra-Ohm wire-wound Resistor is especially adapted for use as a Voltage Multiplier as shown in the above diagram. It is carefully designed to insure an accuracy of 1% and a constant permanency of calibration. Its use is also highly recommended for Laboratory Standards, High Voltage Regulators, Telephone Equipment, and Television Amplifiers and Grid and Plate Resistors, etc.

BULLETIN 62

contains the first complete chart for the use of accurate resistors with microammeters and milliammeters. Send for your copy today. There is no obligation.



MODEL 489 D. C. PORTABLE THREE-RANGE VOLTMETER

750 - 250 - 10 Volts

1000 Ohms per Volt Resistance

A STURDY, miniature instrument, suitable for home or laboratory use—popular because of its small size and unusual electrical characteristics. A truly professional instrument, with all the niceties of design and construction which make a "Weston" so desirable.

Solid black bakelite case, convenient pin jacks, and test cables equipped with pin terminals for insertion in the jacks. Reasonably priced.

Weston Electrical Instrument Corp.
604 Frelinghuysen Ave., Newark, N. J.

WESTON RADIO INSTRUMENTS

PRESTIGE FOR SALES-VOLUME

The Webster Electric Pick-up is universally used in homes and theatres because of its outstanding quality and tone reproducing ability. Its satisfactory record in the past makes it the world's standard of the present. No competitive equipment offers such a group of original and distinctive features. No other pick-up is so looked to for the introduction of latest engineering developments.

The Webster record of performance and sales is of interest to every dealer. The Webster Electric Pick-up enjoys buyer-preference because its rich full-toned music is so appealingly lifelike. It reproduces all the notes of the musical scale, from the highest to the lowest frequencies, with satisfying fidelity and volume.

The new Webster Pick-up is available in two models, both for either battery-operated or A.C. sets. Both models are packed in attractive self-selling cartons. If your jobber has not stocked the Webster, order direct—now!

WEBSTER ELECTRIC COMPANY
Racine, Wisconsin

SPECIAL FEATURES

Webster low-inertia stylus bearing with all-metal pivoting action. Small, light-weight, perfectly balanced head. Highest grade Cobalt magnet of greatest density.

Shock-absorbing arm bearing with pivot at base—exclusively Webster.

Head turnable for needle-insertion.

Volume control in base.
Weighted base.
Cord completely concealed—all bearings free from chatter.
Can be used for standard or talking picture records.

The New Webster Model 2-B includes Pick-up head, separate volume control, and necessary adapters.



The new Webster Model 2-A includes Pick-up head, supporting arm, built-in volume control, and necessary adapters.

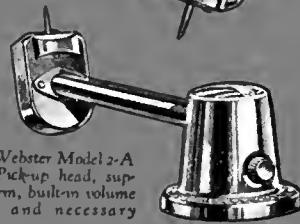

The Webster Electric Theatre Pick-up is for use with 16" records at 33 1/3 R.P.M. Adjustable counterbalance permits correct control of weight on record. Base may be mounted with rubber bands to absorb vibration. With standard or low impedance head.

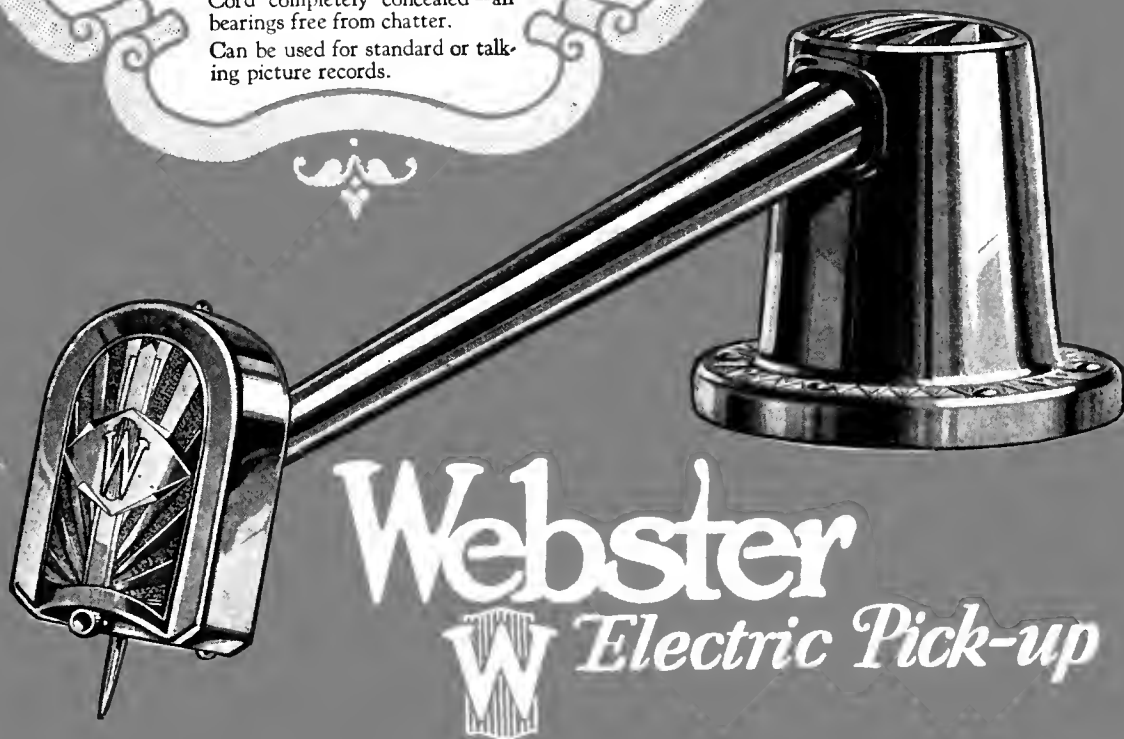

Webster
Electric Pick-up



Carton of four Eveready Raytheon B-H Tubes

WHEN TUBE REPLACEMENTS ARE NECESSARY IN "B" ELIMINATORS
EVEREADY RAYTHEON B-H

MOST "B" power units are designed for the B-H tube . . . the original gaseous rectifying tube. Millions of such units have been sold in the past few years. When tube replacements are necessary, a new Eveready Raytheon B-H Tube will give the greatest satisfaction. Tell your customers what a tremendous improvement in reception a new rectifying tube will make.

Eveready Raytheon B-H Tubes come in handy packages of four tubes each. Always keep at least one full carton on display. The market for these tubes is enormous!

NATIONAL CARBON CO., Inc.
 General Offices: New York, N. Y.
 Branches: Chicago Kansas City
 New York San Francisco
 Unit of **UCC** and Carbon Union Carbide Corporation



Trade-marks

TYPE 360 TEST OSCILLATOR



One of the new test oscillators for the radio service laboratory is now ready. It will deliver a modulated radio-frequency voltage at any point in the broadcast band (500 to 1500 kilocycles) and at 175 and 180 kilocycles. The tuning control is calibrated with an accuracy of 2 per cent.

The Type 360 Test Oscillator is intended to be used for neutralizing, ganging, and tuning of the radio-frequency stages in a receiver, and it is fitted with an output voltmeter for indicating the best adjustment. This voltmeter is of the copper-oxide-rectifier type, and by means of a switch it may be connected across a 4000-ohm load or across the dynamic speaker of the receiver when making tests.

Price \$110.00

GENERAL RADIO COMPANY

30 State Street

Cambridge, Massachusetts

Analyze Set Troubles Accurately & Quickly



Jewell Radio Set Analyzers revolutionize radio servicing. They service screen grid sets, test tubes, and test receivers in service, stage by stage. Binding posts make all instruments available for special tests. Data and instructions simplify servicing, and make it accurate. Every serviceman should have a Jewell. For sale by jobbers everywhere.

FREE to SERVICEMEN

New 64-page booklet containing accurate data on sets of 38 leading manufacturers—139 sets in all—now furnished free to servicemen.



Jewell Electrical Instrument Company
 1642-H Walnut Street, Chicago, Illinois

Send your booklet, "Instructions for Servicing Radio Receivers," also literature describing Jewell Radio Service Instruments.

Name.....

Address.....



Pyrohm Resistors
Accurate — Unchanging

REDUCED sensitivity, low volume, distortion and poor tone quality are the inevitable results of using inaccurate resistors which do not maintain their proper resistance values.

To be assured of satisfactory operation in power supply units and power amplifiers, be sure to specify and use—Aerovox Pyrohm resistors of the proper resistance values and current carrying capacities.

These units are made of the best grade of resistance wire wound on a refractory tube, and protected by a porcelain enamel against moisture, oxidation and mechanical injury.

Send for Catalog

Complete specifications of all Aerovox Pyrohm resistors are contained in a complete catalog which will be sent free of charge on request.

The Research Worker

contains, each month, valuable information on radio design. It will be sent free on request.



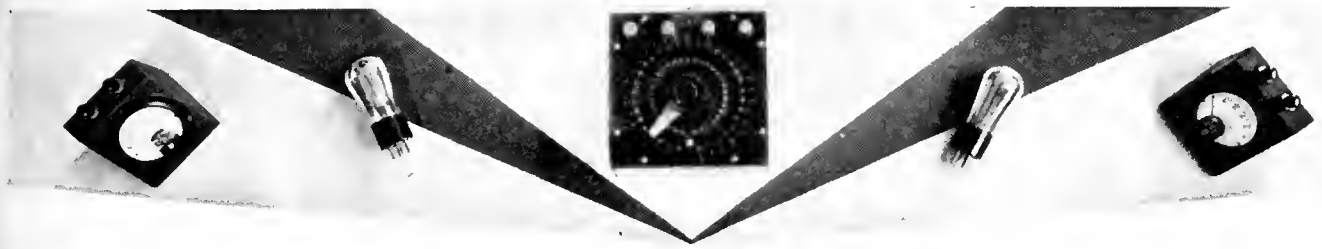

STRAYS FROM THE LABORATORY

Regarding Synchronized Stations

FROM TIME TO TIME the public press is assailed by someone who has a newly discovered scheme for doubling up on the ether by transmitting the same audio-frequency program over several stations which are synchronized to the same r.f. carrier. Such a system is offered as a panacea for those who do not want to pick up the same program at more than one point on the dial—as a panacea for those who wish to decrease the number of stations now on the air, and as a panacea for those who want to increase the number of programs now on the air.

Since there is such recurrent interest and speculation on this matter of putting several stations on the same frequency, it seems worth while to review briefly a paper read in March, 1929, before the Wireless Section of the Institution of Electrical Engineers (London) by Captain P. P. Eckersley and A. B. Howe. Until recently Captain Eckersley was chief engineer of the British Broadcasting Company, and he is well known among all serious and well-informed radio engineers.

In 1926, 1927, and 1928, four British stations operating on low power and transmitting the same program were synchronized to within 100 to 200 parts in a million.

Consider first the unmodulated carriers of two stations. If the stations were situated close enough so that either carrier could be heard if the other were turned off, an interference pattern would be set up. Under these conditions a listener in a locality where the carriers come to him in phase will receive signals which may be twice as strong as those which could be produced by either station, and a listener in a locality where the carriers are out of phase may receive nothing at all.

Now if the carriers are modulated with the same single audio-frequency tone, listeners near either station will receive the modulation undistorted, but listeners midway between the two stations will receive "mush." In other words, turning on the second of two such stations restricts and reduces the service area of the other.

Now suppose the stations send out the same program consisting of tones situated at various parts of the audio-frequency spectrum. Because these side frequencies may not arrive at a listener's receiver in phase, even though the carriers are in phase, the listener will get distorted signals.

To test these and other possibilities, two stations, G5BC and G5RT, were tuned to 610 kc. and maintained there by transmitting a synchronizing signal of 305 kc.

from a third station. This signal was picked up by both stations, doubled, and used to drive the two transmitters. They were supplied with the same program by a 38-mile wire line which connected them. A portable field strength measuring set and a standard receiver were transported to

is supplemented by the indirect ray reflected from the Heaviside layer. At locations remote from the transmitter the latter is the more important; it causes fading and distortion. It seems wise to use antennas which transmit poorly toward the sky and which confine their radiation more nearly to the ground wave. Such radiators are high vertical antennas.

Captain Eckersley states that for large distances between stations, it is better to use low frequencies; for short distances it is better to use higher carrier frequencies. This is due to the fact that the direct ray falls off more with distance as the wavelength is decreased, while the indirect radiation seems to be more or less independent of the distance. Another interesting result of the author's experiments leads to the statement that when 6 or 7 stations share the same frequency, their service areas are not affected by the addition of other stations.

The problem seems to resolve itself into several phases: (1) to provide accurate synchronism between stations either by transmitting a standard radio-frequency signal from some centrally located station, or by means of land lines; (2) to restrict the radiation as much as possible to the ground wave; and (3) to choose properly the location and power of the stations sharing the common frequency.

Measuring Screen-Grid Capacity

Measurement of the extremely small capacity existing between plate and grid in a screen-grid tube is a difficult problem. Comparative measurements are not difficult to make by putting the tubes across tuned circuits and measuring the change in frequency, but to get the capacity in exact units involves a standard of the order of 0.02 mfd.

In *Experimental Wireless* (England), June, 1929, the following method is put forth as a way out of the difficulty. It involves putting another and larger condenser in series with the desired capacity, and measuring the voltage across this large capacity when a known voltage is put across the two capacities in series. Thus in Fig. 1 the voltage is shared by the tube capacity and the large known capacity, which is about 10^4 times as great as the grid-plate capacity whose value is desired.

A potential at 1500 kc. of about 600 volts was generated in a tuned circuit. This voltage was measured by means of an electrostatic voltmeter and applied to the two condensers in series. The capacity is found from

$$C_{g-p} = C_s \frac{E_t}{E_s} \text{ since } C_s \text{ is about } 10^4 \text{ times } C_{g-p}.$$

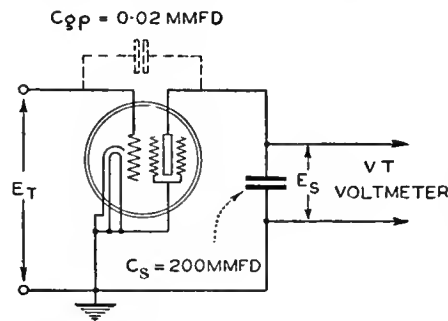

various localities in the field of the two stations.

All types of distortion discussed above were found; in addition it was learned that if one station were five times stronger than the other, the program of the first would be received properly and without distortion. If one station differed by five cycles in carrier frequency from the other, it would be necessary that the first station be ten times stronger than the second at a given locality in order to receive an undistorted signal. If the two stations transmitted different programs but on exactly similar carrier frequencies, the strength of one would have to be from 100 to 200 times stronger than the other in order to receive undistorted programs.

The difficulty in using the same carrier frequency for several programs, or for the same program, comes from the fact that the direct ray from the transmitter

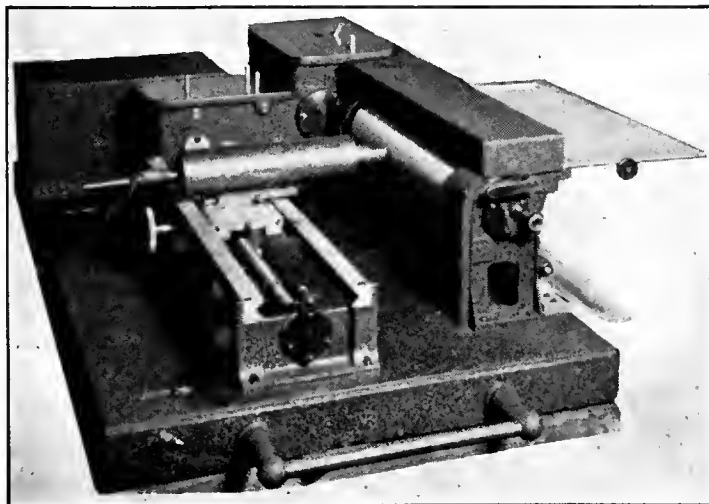

The apparatus pictured above is the new high-speed facsimile receiver developed by R.C.A. for transatlantic service.

IN THE RADIO MARKETPLACE

News, Useful Data, and Information on the Offerings of the Manufacturer

Sonora Screen-Grid Set

SONORA PHONOGRAPH COMPANY, INC.: The Sonora Model A-31 Screen-Grid Low-boy receiver lists at \$149.50. The set is of unit construction, being composed of three separate units; the r.f. amplifier and detector, the a. f. amplifier, and the power supply with an electrodynamic loud speaker. Any one of the three units may be removed readily for servicing. The set uses three screen-grid tubes and power



detector followed by a single stage of a.f. amplification and a push-pull power amplifier with two 245-type tubes.

Zenith Model 53

ZENITH RADIO CORPORATION: This receiver uses a nine-tube chassis with the following features: automatic tuning, screen-grid tubes, double push-pull amplification, automatic volume control, and a large size electrodynamic loud speaker. The receiver lists at \$275.

Jack Horner Speakers

OPERADIO MANUFACTURING COMPANY: Believing that the next big step in radio will be remote control, this company is manufacturing an electrodynamic loud speaker in an artistic baffle designed to be hung from the molding. It is known as the Jack Horner model and it has an effective baffle length of 40 inches. It is made for operation on 110 volts 25-40 cycle, 110 volts 50-60 cycle, and 110 volt d.c.

Temple D. C. Receiver

TEMPLE CORPORATION: To meet the demand for a receiver designed for operation on 110 volts d.c. this company has produced a set using six 112A's and four 171A's. It uses a fourteen-inch electrodynamic loud speaker and is available in two different models.

New Connector Plug

NATIONAL COMPANY: A semi-soft rubber cable connector plug has been developed to be used as simple and effective method of connecting the chassis of an electrodynamic loud speaker field to a power pack.

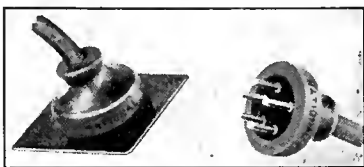

Webster Electric Pick-up

WEBSTER ELECTRIC COMPANY: The new Webster pick-ups have the following features: low-inertia stylus bearing utilizing an all-metal pivoting action; small carefully balanced pick-up head giving a weight on the record of only 4½ ounces; Cobalt steel magnet; shock-absorbing arm bearing with pivot at base; volume control incorporated in base. The pick-up is available in various models either with or without the tone arm or volume control. A pick-up designed especially for use with the Victor Radio, Model 32, lists at \$19.50.

New Tube Socket Designed

CINCH MANUFACTURING CORPORATION: This company has designed a series of radio tube sockets. The sockets are constructed so as to give good contact and with accessible lugs for soldering. For years this company has been manufacturing fasteners for automobile manufacturers.

New Thermatrol Products

THERMATROL MANUFACTURING COMPANY: The new Filtrol No. 460 is designed to eliminate interference that reaches a radio receiver through the a.c. lines. The unit contains a combination of inductance and capacity, and is connected between the light socket and the radio receiver. The Filtrol No. 458 is designed for connection directly to the apparatus producing interference. The Thermatron heavy-duty line voltage control No. 210 is designed to absorb excess line voltage. The device contains four separate outlets to take care of all usual line voltage variations.

Capehart Automatic Phonograph

CAPEHART AUTOMATIC PHONOGRAPH CORPORATION: The Capehart Club Model Orchestrope, No. 28-F, combines an automatic phonograph with a three-stage power amplifier and an electrodynamic loud speaker. It will play twenty-eight records automatically on both sides



at an operating cost of approximately two cents per hour (ten cents per kwh.). The dimensions of the cabinet are: height 41¼ inches, width 45 inches, and depth 23½ inches. The instrument is shipped as a complete unit and the tubes are packed in a box which is placed in the bottom of the cabinet.

Portable Phonograph

Q. R. S. De Vry Corporation: Five different types of portable phonographs are being made by this company. The Model 15 lists at \$15, the Model 20 at \$20, the Model 25A at \$25, the Model 50 at \$50, and the Model 375 at \$37.50. Some models are designed for operation from the a.c. line and others derive their power from dry-cell batteries contained in the cabinet.

Utona Loud Speakers

AMERICAN RADIO PRODUCTS CORPORATION: The electrodynamic loud speakers manufactured by this company are available in various models for either a c. or d.c. operation.

RCA Theremin

RADIO-VICTOR CORPORATION OF AMERICA: The Theremin is a musical instrument being manufactured under an option on the patent held by the inventor, Professor Leon Theremin. The instrument is operated by moving the hands relative to the loop bar which controls the volume and the vertical rod which controls the pitch. The device is actually a beat-frequency oscillator whose output is controlled by the



capacity coupling between the hands of the operator and the looped bar and the vertical rod.

New Microphone

RADIO RECEPTOR COMPANY: This company announces a new line of microphones for public-address and other sound-reproduction purposes. Although designed particularly for use with a Powerizer sound-amplifying system, they may be used satisfactorily with any well-designed amplifier. Three different types are made, a 3½-inch, a 6-inch, and a hand microphone.

Utah Loud Speakers

UTAH RADIO PRODUCTS COMPANY: The Model 66-A Stadium electrodynamic loud speaker was designed for 110-volt a.c. operation. The overall diameter is 12½ inches, the cone diameter being 10½ inches. It is equipped with a full-wave high-voltage rectifier which operates directly from the a.c. line without any step-down transformers. The loud speaker can be used on either 25 or 60 cycles.

The Grebe Synchrophase

A. H. GREBE AND COMPANY: Features of the new Grebe receivers are three screen-grid tubes, hand-pass filters, push-pull amplification, large diameter electrodynamic loud speaker, and automatic line voltage control. The set uses six tuning condensers and contains a special phonograph pick-up input transformer so that modern high-quality low-impedance pick-up units may be used.

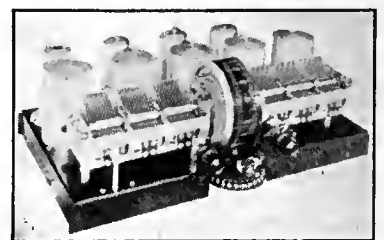

Stewart-Warner Phono-Radio

STEWART-WARNER CORPORATION: The new phonograph-radio combination manufactured by this company is contained in a cabinet of excellent construction and uses a screen-grid receiver in combination with a Gordon phonograph motor. The cabinet has sliding doors and a file for twenty records. List price: \$285.75.

New Freed Receiver

FREED-EISEMANN RADIO CORPORATION: The new Model NR-90 employs an automatic tuning device which permits automatic selection of ten favorite stations. It uses four screen-grid tubes, three as r.f. amplifiers and one as a detector. List price: \$182.50.

New Carryola Products

ALLEN-HOUGH CARRYOLA COMPANY: The combination radio-phonograph cabinet, Model 175, contains an electric motor and turntable together with a Webster pick-up. Space is provided for the installation of any standard radio receiver and loud speaker. The Rotrola is a small portable phonograph designed for 60-cycle a.c. operation.

New Crosley Model

CROSLY RADIO CORPORATION: The Crosley Model 33-S which was announced recently is a seven-tube screen-grid receiver housed in a



Hammarlund Hi-Q 30

HAMMARLUND-ROBERTS, INC.: This receiver is unit built at the factory and comes to the purchaser in the form of several units which can be wired together quickly. The set uses nine tubes with an automatic voltage regulator, a three-stage tuned band-pass filter with screen-grid tubes, a type 245 push-pull amplifier, complete shielding, and a cadmium-plated chassis. To house the receiver nine special cabinets are available including one table model, six consoles, and two phonograph-radio combinations. Complete parts for the Hi-Q 30 a.c.-operated receiver list at \$162.50, parts of the tuner only (no a.f. amplifier) at \$138.65. The complete parts for the Hi-Q-30 battery-operated receiver list at \$119.15 and the tuner only at \$93.80.

Falck Screen-Grid Set

ADVANCE ELECTRIC COMPANY: The Model 11 is a small console receiver using a "Neutrocoil" loud speaker. A neutrodyne circuit with controlled regeneration is employed. List price: \$86.00. The Model 53 is a console set with an electrodynamic loud speaker. It uses screen-grid tubes and a 171A power tube. List price: \$112.00. The Model 23 lists at \$118.00 and uses a screen-grid tube and 245-type power tube.

Centro-Matic Tone Finder

EARL RADIO CORPORATION: The Earl Centro-Matic Tone Finder is an automatic tuning device which permits easy tuning to any one of ten favorite stations by simply pulling a lever. The Earl Model 33 containing this feature uses an eight-tube chassis with a phonograph pick-up jack. It lists at \$179.00.



console cabinet. The cabinet is of walnut veneer. A feature of the receiver is the triple-range control switch to give distant, near-by, and local reception.

New Portable Phonograph

STEVENS MANUFACTURING CORPORATION: The new Stevens portable electric phonographs are made in two models. The type AC is designed for operation from a light socket. The type B is operated from three standard dry-cell batteries placed in a compartment in the case. The d.c. model is designed especially for portable use and it may be played anywhere at any time. Both models are equipped with a mechanical reproducer but an electrical reproducer can, of course, be used.

Sentinel Receivers

SENTINEL MANUFACTURING COMPANY: The Model 666-C is a nine-tube receiver with four screen-grid tubes, two 227's, and two type 245's. It is a phonograph-radio combination and uses a United pick-up and United electric motor. The list price is \$149.50. The Model 666 is similar to the 666-C except that it does not contain a phonograph, being simply a console radio receiver. List price \$99.50.

Gulbransen's New Set

GULBRANSEN COMPANY: The Gulbransen combination radio-phonograph, Model 200, combines all the features of the Gulbransen nine-in-line screen-grid radio set, and has in addition a phonograph compartment in the top. It is equipped with a ten-inch electrodynamic loud speaker and uses five 226's, one 224, two 245's, and one 280. Price: \$235.00.



New Victor Receiver

RADIO-VICTOR CORPORATION OF AMERICA: The Victor receiver is now available in a new cabinet design. It is known as the Model 952. Price: \$215.00.

A. C. Short Wave Set

PILOT RADIO AND TUBE CORPORATION: A new screen-grid short-wave receiver known as the A.C. Super-Wasp has been designed. It uses a special 227-type detector tube preceded by a screen-grid tube. The wavelength range is 14 to 200 meters, although extra coils can be obtained to extend the range to 500 meters.

Sterling Radio Receivers

STERLING MANUFACTURING COMPANY: The Sterling Concertone chassis employs three screen-grid tubes and a two-stage a.f. amplifier with 245-type power tubes in push pull in the output. The electrodynamic loud speaker is supplied directly from the power unit. The Troubadour model lists at \$129.50, the Serenader at \$149.50, and the Imperial at \$187.50. All three sets use the Concertone chassis.

Padded Set Jackets

CHARLES J. WEBB AND COMPANY: This company makes padded jackets for use by dealers to protect radio receivers during shipment. They are made in three standard sizes.

Erla DeLuxe Console

ELECTRICAL RESEARCH LABORATORIES INC.: The Model 30 Erla receiver uses a seven-tube chassis with two screen-grid tubes, two 227's, two type 245's, and one 280. A long and short antenna control is provided on the panel. Tip jacks are provided for phonograph pick-up connection. The Model 30 lists at \$165.00.



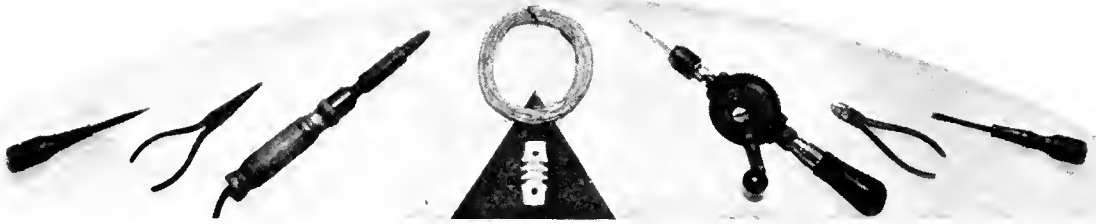

THE SERVICEMAN'S CORNER

Screen-Grid Servicing

SCREEN-GRID problems are beginning to crop up regularly in the Corner's mail. DONALD F. SAMPSON, of Sampson's Radio Laboratory of Central City, Nebraska, writes on the subject as follows:

"One rather interesting experience I had with a defective screen-grid tube was when I found a set (Silver) that went off and on intermittently, and which could be either started or stopped by jarring the receiver. This generally indicates a loose connection somewhere in the circuit. The trouble, however, was found to be a short between the elements of the second r.f. tube.

"Although the Silver receiver is designed so that matching of screen-grid tubes is not necessary to prevent oscillation or to obtain the proper degree of selectivity, I have found that all screen-grid tubes are not good detectors. This is especially true where the tube is used as a power detector. A few cases have also been found where the detector introduced a considerable amount of a.c. hum.

"The most common symptom of an inferior detector tube is lack of 'kick,' and this can almost always be remedied by interchanging the detector tube with one of the other tubes in the set. A poor detector tube may also cause a certain fuzziness in the tone quality of the machine. Of course, at times a noisy screen-grid tube will be found, but so far as the writer has been able to determine, the symptoms and the method of finding the defective tube are the same as for the 227 tube.

"My experience has been, using R.C.A. and Cunningham tubes, that screen-grid tubes are not 'short lived,' but, on the contrary, they will stand just as much abuse as any other heater-type tube. I have carried a Silver receiver on the floor in the rear of my car for over seven thousand miles, and not a screen-grid tube has been changed.

"I found one set in which all the voltages were about forty per cent. below normal, excepting the grid voltage of the 227 tube in the first a.f. stage, which was fifteen volts, instead of one volt. The trouble was found to be in the 227 tube and on replacement all voltages were correct, and the receiver operated properly.

"I have found more trouble with 227 tubes, because of a gaseous condition, than with 224 tubes, and believe that screen-grid tube troubles will be no greater than those encountered with the 227 tubes."

A complete test bench: The interesting test bench and panel illustrated on this

page is part of the equipment used by L. C. Wingard, service manager of the Cleveland Talking Machine Company, jobbers of Cleveland. With it, it is possible to test every piece of apparatus which is handled by the company. A General Radio

these are but part of the apparatus built into, on, behind, and under the bench shown in the picture.

A soldering kink: DOUGLAS B. SEVIN borrows a thought from welding technique in devising an arrangement for soldering in fairly inaccessible places. He uses a carbon rod, taken from a flashlight cell, affixed to any suitable holder. One side of a low-potential source—such as an A battery or a 2.5-volt filament winding—is connected to the carbon and the other to the connection to be soldered. The carbon is pressed lightly an eighth of an inch or so away from the point of soldering, and the joint is almost immediately heated to a solder-melting temperature.

The Crosley Bandbox:

"From observation, I have noticed that the Crosley Model 602 Bandbox condenser gang, gets out of line after a few months' use. It seems that tightening the condenser drive bands too tightly has a tendency to warp the two end condensers gradually. If you examine the defective condenser closely in a case of this kind you will see that the rotor plates are not properly centered all the way across the condenser when it is at maximum capacity. This causes it to be

'in line' at one place and not at another. You will also note that the condenser has two adjustment screws on each side. Line these condensers up properly and balance the set with an oscillator and 'dummy' tube and you will find that the set has the original selectivity and volume."

H. ODELL PUELLES, Service Department, Vaughn's, Inc., Greensboro, N. C.

Data on Zenith sets: WALTER STRAUSS, JR. (W9CMX) runs into screen-grid and other troubles with Zenith sets:

"The early model Zenith screen-grid receiver employed a 224 for the first r.f. stage and either a 250 or 210 in the last a.f. stage. Two small 25,000-ohm resistors in series were used to reduce the 450 volts going to the plate of the last a.f. tube. The reduced voltage, about 135 volts, went to the screen grid. After several weeks of operating one of these resistors is apt to 'go west' and a good indication is: weak oscillations over the entire band; low volume; and broad tuning.

"To remedy this, use a 50,000-ohm resistor with the good 25,000-ohm unit and take out the bad one. The insertion of the 50,000-ohm resistor will cut down the screen-grid voltage to some extent but the volume will come to about par and so will the selectivity. I haven't had any trouble since the insertion of the 50,000-ohm resistor which was about 5 months ago.

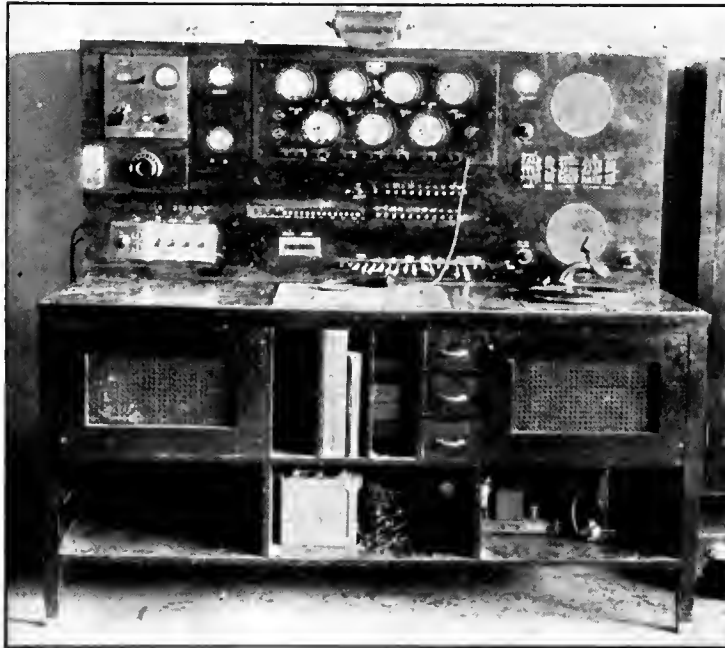

The test equipment pictured above is the apparatus employed by the Cleveland Talking Machine Company. It is designed so that all types of tests may be performed on the apparatus which they sell as wholesalers.

oscillator designed to test Radiola 61's but remodeled so that it will cover the broadcast band; two loud speakers, a magnetic and a Radiola 101, switches for using either low- or high-impedance pick-up units; complete power apparatus furnishing various voltages and currents—all

The serviceman is consistently confronted with the mechanical problems of installation and maintenance. A specific case is the installation of a moving-coil loud speaker so that it affords neither the eye nor the ear. It is unfortunately almost a corollary that for an electrodynamic loud speaker to be efficient acoustically it must present to the eye a cross between the smokestack on Peter Cooper's locomotive and an ironing board.

We should appreciate contributions from servicemen describing the reconciliation of electrical and mechanical efficiency with the dictates of good taste in the well-appointed home—from antenna lead-ins to loud speaker camouflage.

—THE EDITOR.

"In these same models, when a pilot lamp becomes loosened or burnt out it is a very hard thing to put your fingers inside the frame of the dial and replace the lamp. After cutting up my fingers it finally dawned upon me to use a rubber tube with an inside diameter equal to the lamp or a little smaller, and about three or four inches long. After the threads are given a start it is then easy to tighten the lamp all the way.)

"A good rough indication of the 224 and its respective circuit may be obtained by placing your finger on the cap terminal of the tube. If the music stops it is good. If not, it is most likely to be a low tube and should be replaced as soon as possible as it lowers the efficiency of the other tubes."

Servicing Radiolas

M. R. BATTERSBY, in charge of the radio repair department of the Manhattan Electrical Supply Company, New York City, sends along the following data on a portable oscillator for servicing superheterodynes:

"Some time ago I was called upon to design a really portable 175-180-kc. oscillator to be used in servicing superheterodynes. So with two items in mind, namely portability and minimum cost of construction, I built the following oscillator in which a UX-112A tube was used with batteries consisting of a 4.5-volt C battery as the A supply (which is good for about 15-20 hours continuous running of the oscillator filament) and B supply consisting of a small 22.5-volt B battery. If greater output is desired two of these B batteries can be used in series, although two are not necessary for satisfactory operation.

"An aluminum shield can measuring 4.5" high by 5" square was cut to measure 2.5" high by 5" square. This was easily accomplished as the can was of the collapsible type held together by eight screws, allowing the removal of any part. The flat sides and supports were cut with a hack-saw to size and smoothed with a file after which the side supports were drilled and tapped for 3/8 screws so that the top could be fastened on again in the original manner. The 5" by 5" top holds all the apparatus indicated in the diagram and the pictures.



The well-planned service shop of Vaughn's, Inc., Greensboro, N. C., specialists in Sonora, Majestic, and Crosley receivers.

"A feature of the oscillator and one which makes possible its compactness, is the oscillator coil itself which is the secondary coil of an i.f. transformer

any small wire are put on for the pick-up coil. The secondary coil is tuned to 180 kc. with the original condenser supplied in the i.f. transformer for that purpose or by means of a balancing condenser (R.C.A. part No. 2239).

"For 175 kc. a balancing condenser (R.C.A. part No. 2239) is paralleled with the 180 kc. condenser by means of a Yaxley single-pole jack switch. The diagram is shown on this page.

"After construction, the oscillator is calibrated by means of a Radiola 60 receiver for 180 kc. and a Radiola 66 receiver for 175 kc. The method is as follows:

"For 180 kc. the pin jack leads of the 0-5 or 0-10 milliammeter are placed in series with the plate lead of the second detector in the receiver, a Radiola 60. This can be done either by an adapter or by breaking in on the red plate lead at the terminal board. Place all the tubes in the receiver with the exception of the oscillator. Clip a pick-up wire to the middle stator section of the variable condenser bank in the receiver and attach the other end of the wire to the pick-up jack on the oscillator.

With the receiver and oscillator both operating adjust the tuning condenser No. 1 across the coil in the oscillator for maximum reading on the milliammeter which will indicate resonance at 180 kc. If the loud speaker is connected to the output terminals of the receiver the note of the oscillator will be heard with good volume, its pitch depending on the value of grid leak used.

"To calibrate the oscillator for 175 kc. throw the jack switch on the oscillator panel to parallel the secondary condenser No. 1 just tuned, with the condenser No. 2, as yet unused, taking care not to disturb the adjustment of the first condenser. A Radiola 66 receiver is used for this calibration and the procedure is the same as when calibrating with the Radiola 60. The pick-up lead is clipped on the middle stator section of the variable condenser bank in the receiver and condenser No. 2 in the oscillator is adjusted for maximum reading of the milliammeter. After calibrating it is wise to seal the small condensers in the oscillator with a bit of wax to insure the adjustment remaining permanent."

[By substituting a coil of about 100 turns, wound on a three-inch form and centertapped, for the R.C.A. No. 8342, this oscillator may be used for service work on the broadcast band.—Editor.]

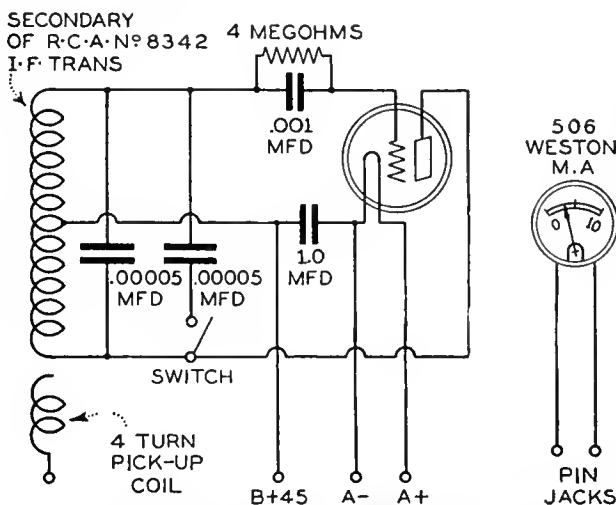

The complete schematic diagram of a fifteen-dollar home-made portable oscillator.

for the Radiola 60 (R.C.A. part No. 8342). The case of the i.f. transformer is taken off, the coil is demounted, and the primary winding is removed. Then four turns of

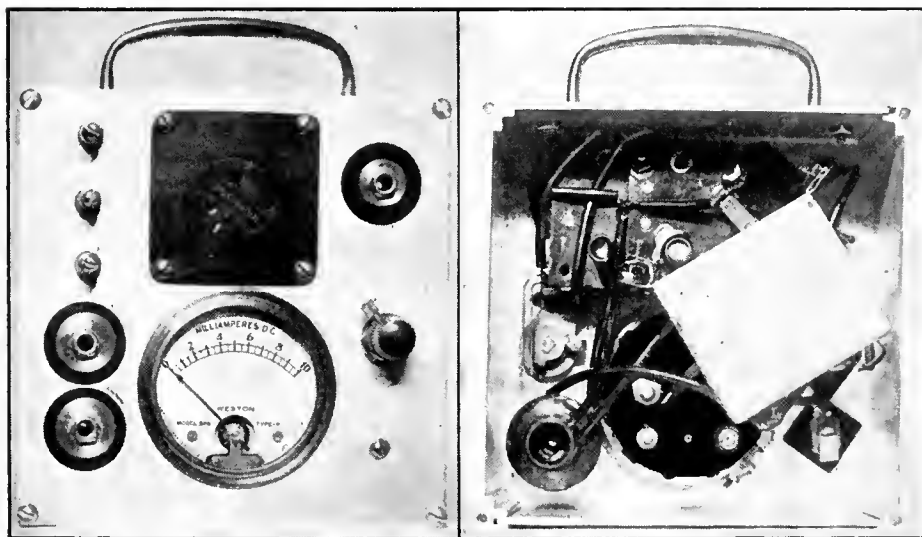

Two views of the portable oscillator described by Mr. Battersby. This instrument was designed especially for servicing superheterodyne receivers.

ELECTROSTATIC LOUD SPEAKERS

By F. J. SOMMERS and G. E. MATTOS

Undergraduates, University of Santa Clara

THE PURPOSE of this article is to describe some interesting features in connection with a recent type of electrostatic loud speaker and to discuss its electrical and acoustical characteristics as determined by engineering tests.

At the present time, as is generally conceded, the electrodynamic loud speaker, which makes use of a moving coil in a strong magnetic field, is the most powerful and efficient sound reproducer that engineering science has developed. It is not only a satisfactory loud speaker from the engineering standpoint, but its even response, good tone quality, and ability to transform comparatively large audio-frequency currents into sound, have made it exceedingly popular with the radio public.

Despite this tendency toward loud speakers of the electrodynamic type, interest has lately been aroused in certain electrostatic loud speakers now in the course of development, which, because of their simplicity, may be manufactured at a comparatively low cost.

Engineers in general are, for good reasons, inclined to look with disfavor upon any device which transforms electrical energy into mechanical through the medium of electrostatic attraction and repulsion alone. Everyone knows that the sources of power loss in such devices are many, that electric charges are prone to leak off before they can be put to use, and that even where the best dielectrics and best design are used, the loss of energy due to dielectric hysteresis and corona effects is liable to be considerable. If high voltages are used, these losses are greatly magnified, though they are also present when comparatively low voltages are employed.

While many claims are being made in favor of electrostatic loud speakers, at the present time there is little engineering data available as to their characteristics, and it was for this reason, coupled with the widespread interest in such devices, that the tests described in this article were undertaken.

Mechanical Construction

The mechanical construction of the loud speaker tested is as follows: The back plate (see Fig. 1A) is a disc of 24 gauge sheet-iron thirty inches in diameter,

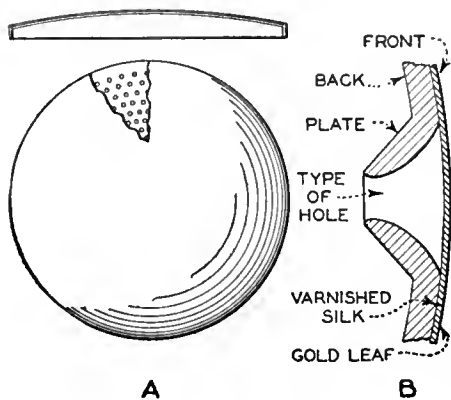

Fig. 1

whose periphery is bent up to form a flange half an inch wide. In this back plate are punched some 2000 quarter-inch holes, the holes being punched so that there is a sharp burr at the back of the plate, but none in front. In addition to this, the back of the plate is "dished-in" half an inch, as shown in the figure. Over this back plate is stretched a membrane of varnished silk two-thousandths of an inch thick, and a layer of imitation gold foil is applied to the outer surface of the membrane. An enlarged cross-section of the loud speaker is shown in Fig. 1B, which shows the type of hole punched in the back plate, as well as the relation of the varnished silk and the gold foil with respect to the back plate.

In using this loud speaker, it may be

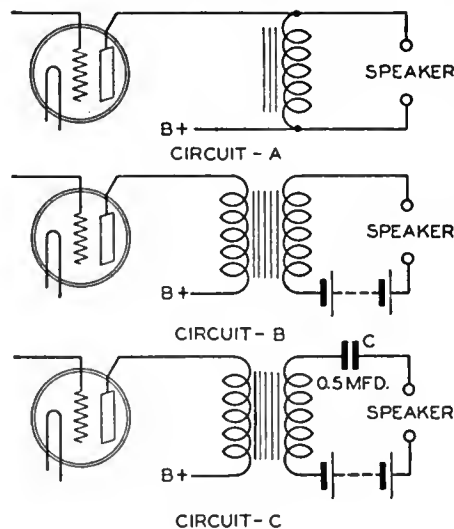

Fig. 2

connected to the amplifier in a number of ways—three of which are shown in Fig. 2. Referring to Fig. 2, circuit A is one in which no external source of bias voltage is used. In circuit B, bias potential is supplied by means of a battery. Circuit C is the same as circuit B, except that the resonant frequency of the loud speaker and effective inductive reactance of the output transformer have been altered by placing a condenser in series with the loud speaker. These circuits were chosen for tests because the results obtained could be analyzed more easily with respect to the effect of the resonant frequencies of the loud speaker circuit and the effect of various bias voltages.

For the sake of clarity in explaining its characteristics, the theory of the loud speaker in question will first be outlined. It can be seen that the electrostatic loud speaker is nothing more than an electrostatic condenser, one of whose plates is fixed, and the other is free to vibrate. When the condenser charges, there is an attractive force which pulls the diaphragm more closely to the back plate. When it is discharged, there is a certain restoring force supplied by the elasticity of the diaphragm which pulls it back to its initial position. It can be seen, therefore, that the dia-

phragm will vibrate in accordance with voltages across the loud speaker.

Source of Sound

It might be thought that the foregoing was the entire theory of the loud speaker, and that the holes in the back plate were merely for the purpose of allowing air to escape. On the contrary, we have found that very little of the sound comes from vibration of the diaphragm as a whole, but that most of it comes from a more intense vibration taking place in the parts of the diaphragm immediately over the holes. It is proposed by the authors that this increased vibration is partly due to distortion of the electrostatic field about the holes, in such a way that there exists a large difference of potential between the sharp burred edges of the holes, and the parts of the diaphragm over the holes. The electrostatic field about the holes is by no means uniform, and changing the shape of the holes may greatly alter the distribution of electrostatic flux lines between the membrane and the back plate. This increased vibration is also partly due to the curvature of the holes from the front inward. As shown in Fig. 4, the vibration of the membrane may be thought of as a progressive process. As the diaphragm rolls inward over the hole in Fig. 4, it can be seen that there is always a comparatively large force on such parts as at A for position 1 and B for position 2.

In addition to this, the authors have found that when large holes are used, the loud speaker responds more easily to the lower frequencies, while if smaller holes are used, it responds better to the higher frequencies.

From theoretical considerations, the response of the loud speaker with change of frequency may be said to depend mainly upon the following factors: mechanical resonance points in the back plate caused by the particular construction used; the size of hole used; the shape of hole used; the electrical resonance effects due to the circuit used in connecting the loud speaker to the amplifier; and the magnitude of the bias potential applied to the loud speaker plates.

It can be proven both mathematically and by experiment that harmonic dis-

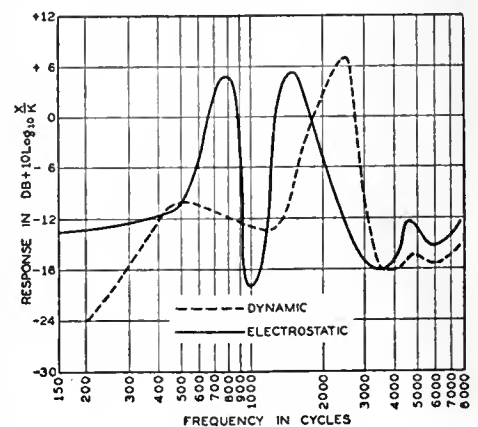

Fig. 3

tortion in the loud speaker can be reduced greatly by application of bias voltages which are large in comparison with the varying audio-frequency voltages supplied by the amplifier.

Electrical Efficiency

The method of test and the results obtained will now be discussed.

For the particular case of a loud speaker, efficiency, as it is generally defined, is not of the greatest interest. Since it is the duty of a loud speaker to utilize all the available power that can be supplied to it by the input circuit, a ratio of output watts to watts input cannot adequately describe its worth. Therefore, in testing loud speakers, efficiency is defined as the ratio of the sound output in watts to the maximum power in watts the supply circuit is capable of delivering under the conditions of optimum impedance. This efficiency ratio in turn is usually expressed in Decibels, or ten times the logarithm to the base ten of the ratio of the output watts to the total available input watts.

In order to test the efficiency of the loud speaker, the authors devised the circuit shown in Fig. 6. The procedure in making measurements was as follows:

The oscillator was first set at a given frequency, as for example, 500 cycles. Switch A was thrown to position (1) and Switch B also to position (1). The alternating component of the voltage drop E_1 , across the non-inductive resistor was read with the vacuum-tube voltmeter. The total power available from the amplifier was then expressed by the equation,

$$P_1 = E_1^2 \times K$$

where K is a constant. Switches A and B were then thrown to position (2) and the sound-power output of the loud speaker was then expressed as:

$$P_2 = E_2^2 \times X$$

where X is a variable function, depending upon the frequency only if the volume of the sound issuing from the loud speaker is kept fairly constant by using larger or smaller inputs. The response of the loud speaker in dB was then expressed by the equation:

$$R = 10 \text{ Log}_{10} \frac{P_2}{P_1} = 10 \text{ Log}_{10} \frac{E_2^2}{E_1^2} \times \frac{X}{K} = 20 \text{ Log}_{10} \frac{E_2}{E_1} + 10 \text{ Log}_{10} \frac{X}{K}$$

Since the value of the term $10 \text{ Log}_{10} X/K$ depends upon the frequency only (assuming a reasonably constant sound output), it will be seen that the response curve of the loud speaker will be raised or lowered at any ordinate by the value of $10 \text{ Log}_{10} X/K$. Readings were thus taken over the frequency range of from 200 to 6000 cycles, and a curve of response versus frequency as abscissas was plotted.

Response Characteristics

Since the actual power represented by the sound coming from the loud speaker is only a few microwatts, it is exceedingly difficult to calibrate the apparatus so that absolute values can be obtained. In order, therefore, to get the response of the electrostatic loud speaker without actually calibrating the apparatus,

a high-quality modern electrodynamic loud speaker was placed in the same position as the electrostatic and the readings repeated over the frequency range of 200 to 6000 cycles—enough readings being taken to make an accurate curve. By plotting the

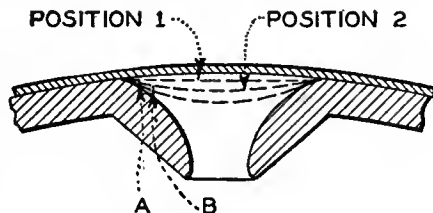

Fig. 4

curves of both electrodynamic and the electrostatic loud speakers on the same sheet, the difference in their responses in dB at any ordinate may be read off the curve, since both curves are raised or lowered at any ordinate by the same amount, namely $10 \text{ Log}_{10} X/K$. Difficulties will be encountered, however, if attempts are made to find the difference in response

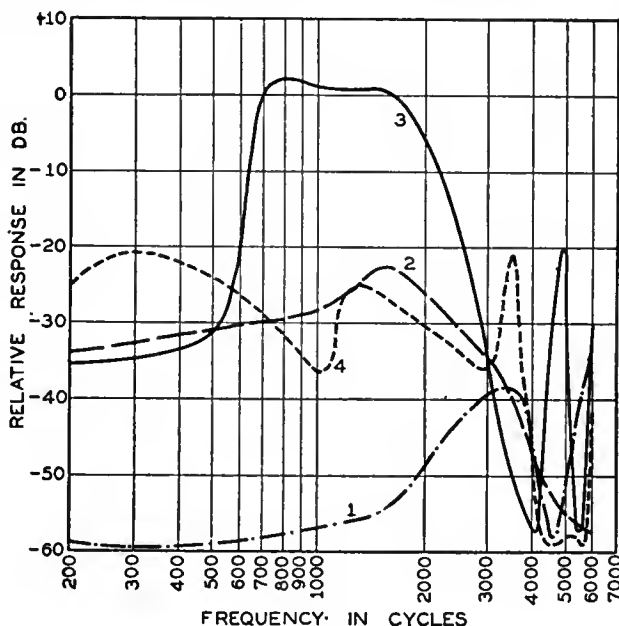

Fig. 5

at ordinates where the responses are of different sign. Fig. 3 shows two such curves plotted on the same sheet. It can be seen that the response of the electrostatic loud speaker is better than that of the electrodynamic by -10 dB, at 200 cycles. At 420 cycles they are equal. At 500 cycles they are again equal. At 1000 cycles the electrostatic response is less than the electrodynamic by -6 dB, at 1800 cycles and 3500 cycles the responses are equal, and so on. This set of curves indicates that the response of the electrostatic speaker was uneven as compared to that of the moving-coil type.

In Fig 5 we have a set of curves of the response of the electrostatic loud speaker

plotted upon the assumption that the curve of the electrodynamic is a straight line. Curve 1 is for the loud speaker using circuit B (Fig. 2) and a bias potential of 25 volts. Curve 2 is for circuit B and a bias potential of 100 volts, and curve 3 is for the same circuit with a bias of 250 volts. Curve 4 shows the relative response of the electrostatic loud speaker when a 250-volt-bias and circuit C are used.

Without going into a detailed discussion of these curves, it can be seen that, in general, the larger the bias potential used, the greater will be the response of the electrostatic loud speaker. It is also seen from curve 4 that changing the resonant frequency of the loud speaker circuit by inserting different values of capacity (0.5 mfd in this case) in series with the loud speaker, changes the shape of the response curve.

In general, it is desirable to have the main resonant frequency of the loud speaker circuit considerably above the highest frequency at which it will be used.

Volume vs. Bias

While a bias voltage of 500 to 600 volts or more is desirable for good results, fair reproduction is obtained with this loud speaker when only 200 or 300 volts is used as a bias.

As shown in Fig. 5, the volume of sound delivered by the loud speaker for a given input voltage increases as the bias voltage is increased. It is also true that harmonic distortion decreases as the ratio between the bias voltage and the amplifier voltages applied is increased. Although in a.c. machinery, only odd harmonics occur, in the case of the electrostatic loud speaker both odd and even harmonics may be present. In other words, if an initial frequency of 500 cycles is applied to the loud speaker, we may have 1000 cycles, 1500 cycles, or any other frequency or combination of frequencies which are integral multiples of 500 cycles. This combination of the original frequency with its harmonics, gives rise to a sound wave which is distorted with respect to the original frequency, and the effect is called harmonic distortion.

When attempts are made to reproduce music by means of a loud speaker in which harmonic distortion is present, the quality is poor. This is the case when the electrostatic loud speaker is operated at low bias potentials. If, however, the bias is increased, this distortion will be reduced. Let the bias potential across the loud speaker be denoted as E and the varying voltage supplied by the amplifier expressed as $e \text{ Cos} \omega t$, then the force upon the diaphragm tending to make it vibrate may be expressed approximately by the equation.

$$F = 2KEc \text{ Cos} \omega t + \frac{1}{2} Ke^2 + \frac{1}{2} Ke^2 \text{ Cos } 2\omega t$$

It can be seen from this equation, that by increasing E, the harmonic term $\frac{1}{2} Ke^2 \text{ cos } 2\omega t$ becomes less important, and if the bias potential is increased to a high enough value, it will be negligible.

The humps in the curves in Fig. 3 are not entirely dependent upon the electrical characteristics of the loud speaker circuit, but can be seen to depend also upon the various mechanical resonances which may be present in the back plate and the diaphragm of

(Concluded on page 122)

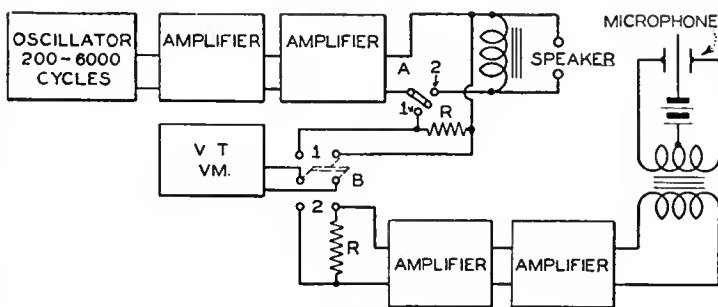

Fig. 6

SETTING RADIO STANDARDS

By **KENNETH W. JARVIS**

Chief Engineer, Sterling Manufacturing Company

A NEW RADIO set is being made. It may be a marvelous achievement or just another radio set. It may be in great demand or unheard of. Just what technical details will make this new set what it will be? Why will it work the way it does and not like some other make of radio receiving set?

The determination of how good a radio receiver should be, and the maintenance of that degree of "goodness" is one of the most fascinating problems connected with the radio industry. It is a curious balance between human discernment and the laws of probability. It involves a conflict between individual temperaments and engineering preciseness. And perhaps most of all, it is a problem in economics from the viewpoint of the manufacturer.

The setting of a standard of performance is a fundamental problem to which a correct answer must be obtained by any manufacturer hoping to stay in the radio business. It is surprising to note the indefiniteness with which this problem is viewed by a great many manufacturers, and it is significant that the most successful producers are those who have approached the problem in a logical manner. The following discussion presents one possible approach, and considers some of the factors involved. Not a great many figures are included, and then only for illustration, as quantitative values are of interest only in specific cases. The relative standards of performance are so varied by market and manufacturing conditions as to make the correct choice a matter of company policy rather than the sole answer to what is the best type radio set to make.

Relative Standards

By relative standard is meant a hypothetical receiver, comparable to previous or competitive models, whose performance capabilities are guessed at as a function of development possibility, cost, and customer demand. It may be an expensively engineered, high priced, refined, beautifully operating receiver, appealing to the tastes of those who can afford such details. It may cost but little, serving to give those less favored in worldly goods some of the joys and static of radio reception. In either case, the operational characteristics have a relative standard about which level the policy of the manufacturing company tends to keep the manufactured article. The company policy, and as a consequence, the relative standard, is influenced by the time and cost of development, the cost of production and materials, and the sales demands. A brand new company would hardly be justified in building the finest and most expensive radio set its first year; the time needed for development alone would prevent such a move. Nor does this mean that the older companies will all tend to go toward higher price and finer

operating receivers. The trend might more nearly be toward that price and performance compromise which would give the manufacturer the greatest profit. As production increased year after year and more money could be spent in develop-

A lower price demand may result in a lowered standard, and conversely. These facts merely mean that to occupy a place in the radio field a manufacturer must choose his relative standard as based on these facts; and for each manufacturer and his particular conditions, a receiver design with a definite relative standard is advisable.

Production engineers are faced with a two-fold problem; to build a certain number of units per day, and to determine which of those units will be shipped and which will be scrapped. Mr. Jarvis in this article discusses the problem of the engineers who must set performance limits on radio receivers and component parts; he discusses from a practical standpoint what the passing and rejection limits should be, the relation between performance and cost, and other factors which are no less vital to a successful radio manufacturer than the careful laboratory design of the apparatus.

—THE EDITOR

ment, the relative standards of that manufacturer might increase. Long experience in manufacturing, refinement in methods of production, and fabrication of materials tend to raise the relative standards. Changing customer demands react in changing the performance standards.

Absolute Standards

By absolute standard is meant a standard working model, which is copied for production as nearly exact as economically possible. It represents, crystallized into facts, the fancies of the relative standard. This standard is established and built in three steps. First, the details required are added to the relative standard by the management of the design division. Usually this means the individual highest in the organization interested in the radio receiver. In the case of a radio receiver manufacturing company this is customarily the president. For more diverse concerns, it may be the vice president or manager of the radio division. These details may cover the suggested size, appearance, manner of construction, sensitivity, selectivity, fidelity, output, number and manner of controls, type of circuit, maximum possible cost, date for production, number to be built, and those extras which may serve to make the product more marketable. Meetings between the executive, engineering, production, and sales departments serve to resolve difficulties and effect compromises. As a result an absolute standard (still on paper) is evolved which the engineering department believes can be constructed in the time available and at the cost specified, and which the production department can build. This is the first step.

As a second step, the engineering department takes these ideas and builds a model which conforms as close as possible to the proposed absolute standard. This model must represent previous development work and the experience of the engineers in charge. Newly proposed additions must be developed so far as possible in the time available. General development work, applying previously determined factors, must be carried on with this specific receiver in view. When engineering principles are applied to produce a desired performance in a physical model, cost studies must be made to show whether the method of application is the cheapest and whether the result justifies the cost. As a result of this work and study, a receiver is evolved approximating the characteristics desired for the absolute standard. Unfortunately, due to human limitations, it is seldom possible for the engineering department to realize all of the ideals of the first chosen absolute standard. A compromise is effected, sometimes bitterly, for competition is keen, but a second stage.

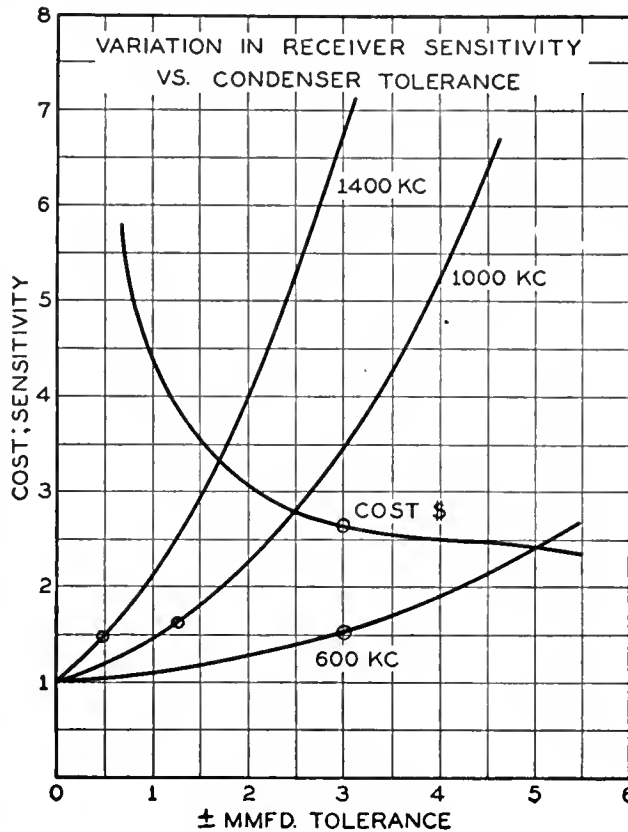

[Fig. 1

in the making of an absolute standard has been passed.

Production Starts

The engineering department model is then copied, drawings are made, dies constructed, and parts purchased. The planning and production departments disassemble and reassemble, figuring labor costs and the most economical way of doing things. Minor changes are made to gain savings of time and material, and to conform with better production methods. Preliminary production work builds a dozen or more samples, each of which is examined and measured, noting how it fits into the scheme of things. If these samples prove satisfactory, the real production is started. Cautiously, for even the engineers sometimes slip, the production increases, the variations and the effect of production expediencies being carefully noted. The production average is checked against the sample average and against the engineering department standard. Differences are corrected or compromised, and the production grows. As a result of this mass copying, the absolute standard loses its individuality; it becomes an average value. There is no longer any single model which is the standard. The absolute standard has been reduced from an intangible idea to a physical reality, and back to a synthesis of microvolts per meter, band width in kilocycles, and percentage responses at 60 cycles. The setting of the absolute standard is complete.

A second problem which should be coincident with the setting of the absolute standard but is usually subsequent thereto, is the setting of the passing and rejection limits of the individual units. There are both absolute and quantitative rejections, mechanically and electrically. In the case of mechanical details, an absolute rejection might be due to a broken dial, or a defective socket. Mechanical quantitative rejections might be due to play in drive mechanism, scratches, etc. Electrically the absolute rejections might be due to no signal or oscillation. Quantitative rejections electrically might be due to low sensitivity, poor selectivity, bad quality, too much a.c. hum, and low overload capacity. The mechanical defects, both absolute and quantitative, are usually caught by competent inspectors who use their own discretion. Electrical defects are caught by meters which are calibrated to indicate the values of the relative performance characteristics. A failure of the meter to read a predetermined value on any test means a rejection. All of which sounds simple, and it is simple, if these values are correctly predetermined. It is in the determination of these limits that the engineer is prone to err.

Rejection Limits

Inspection to determine the electrical performance of radio receivers may be viewed from two standpoints. The inspection and the limits may be set to maintain a high quality of product, or to detect and reject a subnormal set. The first viewpoint is the customary one; the second is the correct view from the economic standpoint. Nor are these two views synonymous as a first impression might indicate. To insure a high quality of product, all units should closely approach

the absolute standard in all electrical characteristics. If the rejection limits correspond to the value placed on the absolute standard it is obvious that all sets shipped will be equal to or better than the absolute standard. It is equally obvious that only 50 per cent. of the receivers built will be shipped, as the absolute standard has been chosen as the average of all the sets produced. Such a limit is ridiculous. If the limit is pushed further toward a lower standard, more sets will

watts to 15 watts be a cause for rejection if the receiver is to be used in a small home. If a manufacturer can show that 50 per cent. of his receivers are used for local purposes only it will undoubtedly, and justifiably, result in a broadening of his sensitivity limits.

Accessory Variations

Another method of determining the allowable variation in receiver characteristics is to consider the accessory variations. It seems illogical to insist on maintaining production limits much closer than the variation resulting from factors over which the manufacturer has no control. A reasonable figure at first guess is to hold the set variation within 50 per cent. of that due to the accessories. In the modern radio set six, seven, or eight tubes are used. While the deviation in these tubes (mutual conductance) approximates 15 per cent., the effect on the set characteristics may be more or less, depending on the product of the stages and the criticalness of design. Measurements of the receiver characteristics with high and low tubes will show the magnitude of the variation. Line voltage variation, if not compensated, also causes a performance variation. Some receivers are quite critical to voltages, others seem to vary in direct proportion, while in one instance, over the normal voltage range of 105 to 125 volts, the sensitivity was almost independent of the voltage. Loud speaker variations may also allow the receiver proper to have greater permissible variations. The place where the receiver is operated, as in a large room, or in a location with poor acoustic conditions, influences the sensitivity and quality demands. One of the greatest variations lies in the "pick-up" ability of the antenna used. When the apparent sensitivity of a receiver can be quadrupled by merely increasing the size of the antenna, why manufacture and hold it within 10 per cent. of the absolute standard? Combining all of these accessory variations gives a figure which is surprising as a possible variation for an individual unit.

While hardly a direct method for determining the rejection limits, a major influence is the repair cost. If the repair cost is high, as is generally the case, it is economical to put more money into making a uniform product and thus cut the percentage of rejections. This, based on nonuniformity of the product, means relatively wider limits. Conversely a low repair cost or a high scrap value tends to narrow the rejection limits. When the cost of rejection and repair becomes appreciable with respect to the original cost estimate, poor engineering, poor production methods, or poor setting of the rejection limits are indicated.

As before indicated, a general method of setting the rejection limits is to adjust them so as to reject arbitrarily X per cent. of the sets built. This is fundamentally not a standard at all as it is too easily changed to meet production demands. The X per cent. rejected tends to raise the standard while the 100—X per cent. meets the production demands. While this method is hardly good business, it is unfortunately quite common.

Another Method

Any of these methods might be used if the object of the inspection tests is to

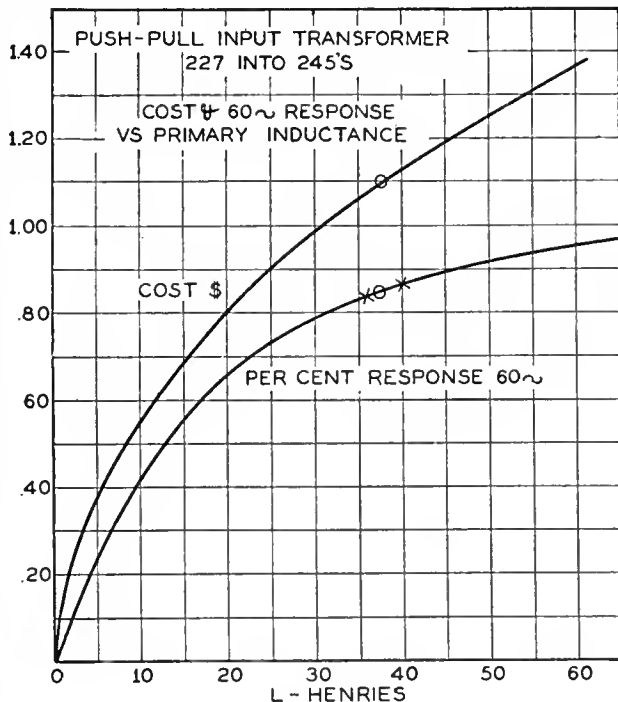

Fig. 2

be passed and fewer rejected. How far should this "pushing" be carried on? What is a safe basis for setting a rejection limit?

There are several methods which might be used to determine what variation in product should be allowable and so determine the limits of rejection. Take as a first method that of customer discrimination. By many experiments it is shown that the average ear cannot detect a difference in sound intensity of less than 15 per cent. (Fletcher: *Bell System Technical Journal*, Vol. IV, No. 3, p. 376). It might be foolish to maintain limits so close that a single individual could not hear the difference. The average customer expects a slight difference between units. He knows that all receivers cannot be identical. Should

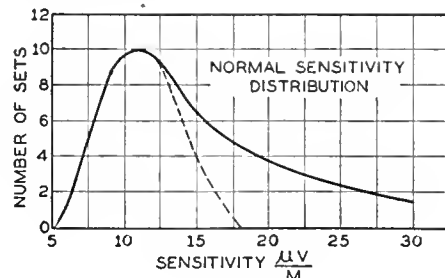

Fig. 3

not the manufacturer capitalize on this expected difference in units by broadening his limits? Then again, many receivers are used in certain ways where limits do not greatly matter. Certainly a 10 per cent. reduction in sensitivity will not affect the intrinsic value of a receiver used for local reception only. Nor will a reduction of possible power output from 20

merely keep the quality standards high. However, a brief consideration of what a radio receiver consists of, and its primary object, shows that the above methods are quite wrong. The limits should not be set as a secondary standard from the absolute standard, but the absolute standard should be determined as the mean probable variation from the minimum permissible performance rating. The comparison is between determining the average of production and setting logical limits therefrom, or the initial choice of a passing point, with the receiver then designed so that all normal units will satisfactorily pass.

This seems a fine point, but it means the difference between a smooth running engineering, production, and inspection system, and one which must continually make engineering changes while in production, and endure the resultant changes in the absolute standards and rejection limits. If this ideal can be brought about, as is gradually being done, a receiver can be designed, produced and marketed with a minimum of friction and expense. It requires a careful consideration of design factors to produce the most economical receiver.

Assume it is desired to produce and market a receiver with a sensitivity of 20 microvolts per meter or better. If the absolute standard is fixed at 15 microvolts, a high degree of uniformity is necessary so that the variation should range only between 11 microvolts and 20 microvolts. A close inspection and close limits on the individual components in the receivers must be maintained. This means a high cost for the parts and an excessively high cost for the completed set. Or if the absolute standard be set at 10 microvolts, the fundamental design will be more expensive, perhaps due to the addition to another stage of amplification, better coils and better shielding, etc. However, the individual components will be less expensive due to the greater permitted tolerances, for the overall of the set may vary between 5 and 20 microvolts. (Note that the absolute standard is not the *average* of the two extremes of sensitivity of the normal receiver. The absolute standard is more nearly the geometric mean of the two extremes.) The total cost of the set may thus be less with an absolute standard of 10 microvolts than with a standard of 15 microvolts if 20 microvolts is determined upon by company policy as the rejection limit. It is obvious, therefore, that the methods of determining the absolute standard as outlined in the beginning cannot be followed so simply if the most economical design is to result. If both a maximum and minimum performance rating is desired, the choice of these limits is truly an economic problem. Too great a sensitivity and oscillation may result. Too poor a sensitivity and the set will not match its competitors. A demand of too great a uniformity (close plus and minus rejection limits) will increase the cost enormously.

Limits vs. Cost

This method of setting limits of performance as based on cost and company policy, rather than an absolute standard plus arbitrarily set limits, is ideal. It is not always possible to make the best choice due to time limitations. However, the practice of setting a desired absolute standard the *proper* amount better than the rejection limits, is a step in the right direction, and is a step which should be taken whenever a new receiver design is proposed. It is quite apparent that the effect on the overall performance of the receiver of each individual component

must be known in order to approximate this ideal method of setting receiver standards and rejection limits. On the same curve must be plotted the cost of the component *vs.* the characteristics of the component. Often the correct characteristic of the component desired at a given cost can be determined at a glance. At other times the proper design of the component can be determined only when other parts of the receiver are considered. The idea involved is simple and logical. Hold the limits on those critical components close to the desired value and do not spend good money to hold those non-critical factors close to a limit.

It is obvious to most engineers that to hold a fixed resistor to within plus or minus 1 per cent. of its rated value is uneconomical, while to hold a variable tuning condenser to approximately the same limits is quite advisable. Yet, even in the case cited, it is doubtful if many could show the actual variation in receiver performance with variation in resistance or tuning capacity. It is customary at present to purchase fixed resistors under a plus or minus 10 per cent. guarantee. Why? Is this limit too close or not close enough? The answer lies in its proposed use. There is a growing tendency to use resistors of plus or minus 5 per cent. for bias voltages, and as high as plus or minus 30 per cent. for use as grid leaks.

Actual Data

Two curves showing such actual design data are included to illustrate these points. The first shows the variation in receiver sensitivity as the tolerance in the tuning condenser is increased. This receiver used a four-gang condenser and for these data two condensers were placed at the maximum indicated plus tolerance and two at the negative tolerance. The average of all possible combinations of the four condensers with any chosen tolerance is taken at the observed point. As this receiver is a variable capacity tuned instrument, the capacity has a greater value as the frequency is decreased. A given deviation in capacity is a smaller percentage of the tuning condenser at 600 kc. than at 1400 kc. and results in a smaller change in sensitivity. Taking the relative sensitivity at 600 kc. when perfectly tuned as one microvolt per meter, and allowing a 2-micromicrofarad tolerance, then the sensitivity will be reduced about 25 per cent. to 1.25 microvolts. The same tolerance at 1000 kc. would reduce the sensitivity to 2.3 microvolts per meter and at 1400 kc. the sensitivity would go to about 4 microvolts per meter. The cost of the condenser gang is given as a function of tolerance allowable. The increased cost with increased accuracy is obvious. This curve refers to the relative cost of the condenser in the 600-kc. position only. The deviation between condensers usually decreases as the rotors are turned out of mesh with the stators. It is fortunate that this is true as it would be difficult to maintain a large capacity within the variations allowable at 1400 kc. With this data available, what capacity variation should be set as the limit permitted? In this case the limits were set as shown by the circles, the tolerances being plus or minus 3 micromicrofarads at 600 kc. with a resultant sensitivity variation (due to this factor alone) of minus 55 per cent. At 1000 kc. the corresponding values are 1.25 micromicrofarads and 65 per cent., and at 1400 kc. they are 0.5 micromicrofarads and 45 per cent. The cost with these limits is approximately \$2.70. Incidentally it is obvious how important it is to align properly the minimum capacity of all circuits at high frequencies to maintain the sensitivity.

The second curve refers to the design of an audio amplifying transformer working from a 227-type tube to a pair of 245-type tubes in push pull. The turns ratio on each side is a 2 to 1 step up. The calculations for cost assume that both copper and iron increase as the inductance increases. This is necessary to keep the cost at any chosen inductance at a minimum. Too much iron, or too much copper increases the cost above that of a correct design. In this case an inductance of about 38 henries was chosen, giving 85 per cent. response at 60 cycles and at a cost of approximately \$1.10. Careful check on the production enabled these transformers to be held to quite close limits. A variation of plus or minus 5 per cent. was allowed as shown by the "x" marks on the response curve. The upper limit was never strictly held as this limit was seldom reached. An upper limit might be more necessary if there were danger of producing too great an a.c. hum in the output. The data on variation in cost versus the permissible variation of inductance is not complete for this transformer and will be more a function of the percentage of rejection due to errors in winding, rather than a function of design with permitted variation in mind. This is a case where too close a limit is inadvisable as the cost for maintaining reasonable limits is a very small part of the total design cost. In the case of the variable condenser a large percentage of the cost is directly attributable to the necessity for maintaining close limits.

The list of the various components and the suggested limits for the radio receiver might be continued indefinitely. Radio-frequency inductances are grouped by selection and matching. The number of groups, and closeness of matching is determined by the cost for uniformity of production, the cost of the testing and matching operation, and the variations in set performance as a result of the individual coil differences. Such balances between cost and performance are obviously necessary to build an economical set, yet are passed up because of ignorance of the effect of individual variations.

By-pass condensers, resistances, chokes, and like parts have a reason for being the values chosen. Likewise the tolerance allowable should be a proper correlation between cost and overall performance variation. No one answer can state what the limits on any part should be; the cost and criticalness of the unit make limits from $\frac{1}{2}$ to 50 per cent. justifiable as a matter of good design.

After the limits on the individual components are chosen to give the most economical design, it must be remembered that the effect on the normal receiver may be the sum of the best conditions or the sum of the worst conditions. If sufficient data is obtained and the design is correct, the sum of the worst conditions will approximate the limits as originally decided upon. Fig. 3 shows a performance curve taken upon a group of receivers. This shows the number of receivers having any given sensitivity. The actual receivers had the characteristics as shown by the solid line. The dotted line indicates the limit of sensitivity as based upon the sum of the individual components. The difference indicates the change in components due to handling, errors in original inspection or defective assembly. The limit in this case was actually set at 20 microvolts, a slight tolerance due to production idiosyncrasies. No upper sensitivity limit was set, although sensitivities as low as 5 microvolts were observed. An upper limit might be desirable if there was a tendency

(Concluded on page 126)

THE PHILCO "95" SCREEN-GRID PLUS

By WALTER E. HOLLAND* and W. A. MAC DONALD†

*Chief Engineer, Philadelphia Storage Battery Company
†Chief Engineer, Hazeltine Corporation

DURING THE past few months the Engineering Department of the Philadelphia Storage Battery Company has been working in cooperation with the laboratories of the Hazeltine Corporation to produce a moderate-priced commercial broadcast receiver that would utilize all the advantages and overcome all possible disadvantages of the screen-grid tube. Furthermore, it was intended that this receiver embody a practical automatic volume control system of the type described by H. A. Wheeler, of the Hazeltine Corporation, in a paper he presented before the I.R.E. in November, 1927. (This paper gave data on a method using a two-element tube as a combined detector and automatic volume control in a radio receiver.) Such a receiver has been designed and was announced by Philco about September 1, 1929. It is known as the Model 95 Screen-Grid Plus.

It has been general practice in the design of receivers with automatic volume control to use an ordinary three-element tube as the detector and to employ an additional tube in the circuit to control the volume automatically. This latter tube is operated on the lower bend of its Eg- I_p characteristic, its grid being excited by the output of the r.f. amplifier across which the grid-filament circuit is connected. The plate circuit of the tube is used to control the volume automatically by supplying to the control grids of the r.f. amplifier tubes a negative voltage proportional to the output of the r.f. amplifier.

Only One Rectifier

In such a circuit the automatic volume control tube is actually working as a detector, the changes in average d.c. plate current with changes in input voltage being used to supply negative bias to the r.f. amplifier grids. In the plate circuit of this tube there are, of course, audio-frequency currents, but these are bypassed to ground by means of by-pass condensers. In a sense, therefore, such sets contain two detectors or rectifiers. In one rectifier, the detector, the audio-frequency output is used to supply signal voltages to the audio-frequency amplifier and the d.c. component of plate current is not used. In the other rectifier, the automatic volume control tube, the audio-frequency components are not used and the steady d.c. component of the rectified signal is used to control the volume. Why not use a single rectifier and utilize both components of its output? This is possible and in the Philco 95 a

two-element tube (227 type with grid and plate tied together) is used to rectify the r.f. signal and to supply both an a.f. signal for the audio-frequency amplifier and a d.c. bias voltage to the r.f. amplifiers.

The two-element rectifier, when its return circuit has a high d.c. impedance, is linear over practically its entire rectification curve. In this particular receiver it is

than the time of a single cycle of the lowest audio-frequency current it is desired to amplify. Actually the control system should be designed so that its time constant (the time it takes to effect the gain) is comparable with the period of the lowest desired audio frequency. The time constant of the volume-control circuit is determined by the values of the resistance and by-pass

condensers in the r.f. grid bias circuit, and in this particular receiver the time constant is about one fortieth of a second so that the circuit nearly reaches equilibrium in about one twentieth of a second. Such a value of time constant has a negligible effect on low-frequency modulation down to twenty cycles.

Tuning the Set

Automatic volume control receivers are generally rather difficult to tune by ear because the volume is essentially constant over several degrees of the dial. The more "perfect" the control system the more pronounced is this effect. This problem can be overcome either by means of a tuning meter to give a visual indication of resonance or by designing the control system so that a fairly definite peak is audible to the ear as the set is tuned through a station. After all, absolutely complete equalization of the volume is not essential (differences in the percentage modulation of different broadcasting stations will prevent any system, no matter how perfect, from giving absolutely

equal volume from all stations) and it seemed advisable to the designers of this receiver to make a slight peak apparent in the tuning so that the user of the receiver would be able to tune the set in a normal manner and not have to learn some new method of tuning, such as tuning by means of a meter. Everyone who has operated this receiver has had no difficulty in tuning it accurately to resonance by listening to the output of the loud speaker.

The automatic control is effective over a ratio of signal voltages of 300 to 1, and in combination with the local-distance switch, which gives a 40 to 1 change, complete control is obtained over a ratio of 10,000 to 1. In normal operation the r.f. input to the rectifier is about 5 volts. No better indication of the effectiveness of the volume control circuit can be had than by tuning in an average station with the "local-distance" switch in the local position, and then switching to the distance position. This changes the input voltage in a ratio of 40 to 1—and there is but a barely perceptible change in volume as the switch is

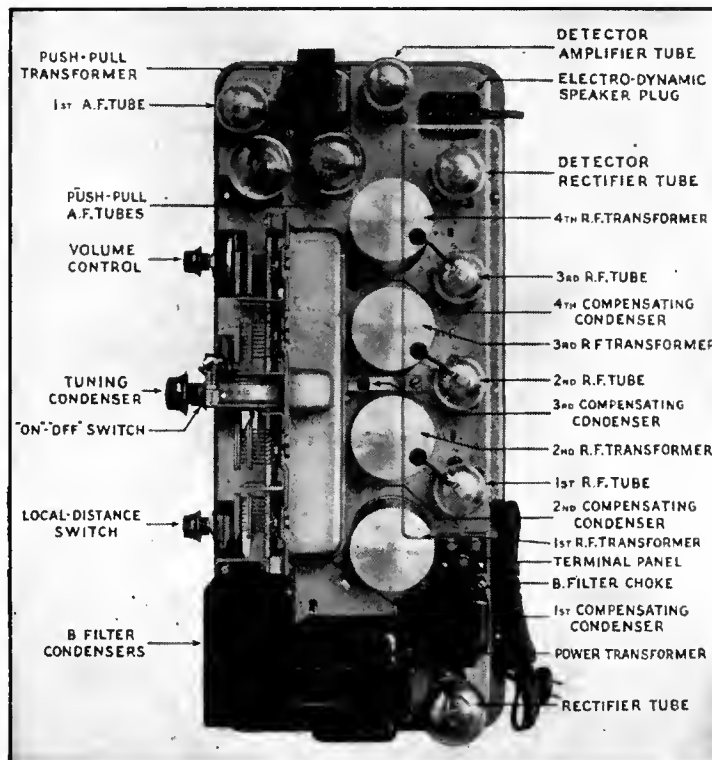

The location of all parts on the Philco 95 chassis is clearly indicated in the above picture.

linear from about 1 volt up to over 100 volts input. Such a detector gives, therefore, the much desired linear detection characteristic (unlike the three-element rectifiers which are linear over only a small part of their detection curve, the two-element tube is linear over practically its entire curve) and it is also devoid of any overloading, even at input voltages far in excess of those at which it operates in this receiver. Actually, overloading of this type of detector can be due only to operation of the tube at input voltages in excess of the maximum safe value. These properties of a two-element detector contribute to the simplicity of the system and at the same time the signal modulation is rectified without distortion.

All automatic volume control systems must be designed so that they will not seriously affect low-frequency modulation. If, for example, the control system were instantaneous in action, the control circuit would function to eliminate much of the modulation in the incoming r.f. signal. The control system should not be able to control the gain of the system more rapidly

thrown. The automatic volume control in this receiver will automatically compensate all signal fading that could be compensated by continually adjusting a manual volume control.

On the control grids of the r.f. tubes there is a steady d.c. bias of approximately 3 volts. The volume control circuit functions, of course, to increase these biases. The first two r.f. tubes receive the full grid-bias voltage available from the rectifier. However, to prevent distortion in the third r.f. amplifier stage, the third r.f. tube receives only half this bias.

The antenna circuit arrangement is interesting. In the first place the antenna primary circuit is resonant at a frequency less than 550 kc., which makes the antenna circuit tuning substantially independent of the size of the antenna—the circuit also gives a uniformly high voltage step-up over the entire band. These high inductance antenna circuits were first introduced into broadcast receivers by the Hazeltine Corporation about 1926. Since then their operation has been somewhat improved by the addition of some dead-end turns which increase the capacitive coupling between the antenna primary and the tuned secondary. The 5000 ohms which is in parallel with the antenna coil helps to reduce any periodicity of the antenna circuit and make it nearly aperiodic. The local-distance switch connects into the circuit, for local reception, a 20-ohm resistor in parallel with the 5000-ohm resistor.

Coupled Tuned Circuits

Ahead of the first screen-grid tube, two tuned circuits are used. These tuned circuits are coupled together with both the mutual inductance, L , and the mutual capacity, $C = 0.015$ mfd, the former predominating at the high frequencies and the latter at low frequencies. At 1500 kc. the inductive coupling is below the optimum value so that the circuits are coupled quite loosely at the high frequencies. This gives high selectivity at the high frequencies where it is so badly needed. At the low frequencies the capacity coupling is important and the coupling reaches the optimum value around 550 kc. This effectively couples the two circuits quite closely, thereby decreasing the selectivity and preventing serious sideband suppression. The combination of the two effects gives a selectivity characteristic for the antenna circuits which is quite uniform over the entire band. It will be appreciated that these two tuned circuits ahead of the first tube will effectively prevent cross talk.

The r.f. amplifier as shown by the circuit diagram (Fig. 1) employs three screen-grid

tubes. Between the first two tubes are tuned transformers which give an average gain of about 20 per stage. With the output capacity of the screen-grid tube the primaries of these transformers are resonant at a frequency slightly above 1500 kc. The gain at the high-frequency end would, with such a circuit, be expected to increase but this effect is prevented by the capacity coupling existing between the plate and grid ends of the primary and secondary coils. The capacitive coupling partly cancels the inductive coupling and prevents the gain characteristic from rising. This is not a "losser" method and therefore keeps the full selectivity.

Untuned R. F. Transformer

Because of the characteristics of the two-element detector it is preferable not to couple it to a tuned transformer. An untuned transformer is therefore used, the gain of this circuit averaging eight over the broadcast band. The 13,000-ohm resistor across the primary of this transformer damps out any resonant peaks.

There is one other point of interest regarding the r.f. amplifier. As stated previously, the capacity coupling between the first two tuned circuits is due to the 0.015-mfd condenser which is effectively in series with the tuned circuits. So that all the tuned circuits will track properly similar 0.015-mfd condensers are placed in series with the following tuned circuits, and all these three condensers are used to bypass the bias voltages.

Regarding the a.f. amplifier circuits, it will be noted that the output of the two-element rectifier is connected directly by resistance coupling to the grid of the following 227 a.f. amplifier tube. An ordinary detector functions in the dual rôle of amplifier and detector, but we have in this set two tubes that in combination do what the detector does in an ordinary set. Therefore, the two-element detector and automatic volume control circuits associated with these two tubes (the two-element detector and following amplifier) has been termed by Philco a "multiplex detector circuit." The output of the second 227-type tube of the multiplex detector circuit feeds into a resistance-coupled stage consisting of a 500,000-ohm plate resistor, a 0.015-mfd. coupling condenser and, in the grid circuit of the next tube, a 500,000-ohm potentiometer, which is the volume level control.

Volume Control Circuit

After all these years that have seen a gradual trend towards the location of the

volume control in the r.f. amplifier, it is interesting that it has once again returned to the a.f. amplifier. Probably it has returned to stay. Technically it is sound to control the sensitivity of the r.f. amplifier by means of automatic circuits designed so that there is applied to the rectifier a value of signal just sufficient to load up the power tubes when the a.f. volume control is set at maximum. The detector then works at a constant level, and the circuit can be designed so that at this particular level the detector circuit produces minimum distortion. Such principles will, we believe, be generally adopted within the next few seasons.

The 227 detector-amplifier, V5, is supplied with a value of grid bias which is a function of d.c. rectified current of the two-element rectifier. The circuit constants are such that the grid bias voltage is always slightly greater than the peak value of the a.c. signal applied to the grid. In this manner it is impossible for the grid of the tube to swing positive on the audio peaks. The sensitivity of the entire receiver is essentially constant at about 5 microvolts per meter throughout the entire broadcast band—this sensitivity is obtained, of course, with the volume control at maximum and the local-distance switch in the distance position.

Summary

In summary the features of this receiver are:

1. Two-element detector tube giving true linear detection and no overloading on signals up to 100 volts input—an input greatly in excess of that possible.
2. Automatic control of volume and fading, giving, in conjunction with the local-distance switch, satisfactory control of all field intensities in the ratio of 10,000 to 1.
3. A "multiplex detector" being the name applied to the use of a two-element detector in combination with an ordinary three-element tube working as an a.f. amplifier direct connected to the output of the two-element detector.
4. A local-distance switch to prevent overloading on strong local stations.
5. Uniform-gain antenna and interstage coupling circuits to maintain a constant sensitivity of about 5 microvolts per meter throughout the broadcast band.
6. Simplicity of operation—the manual volume control need be touched but seldom.
7. Excellent fidelity due to the linear and non-overloading detector together with the resistance-coupled first a.f. stage and a push-pull power stage.

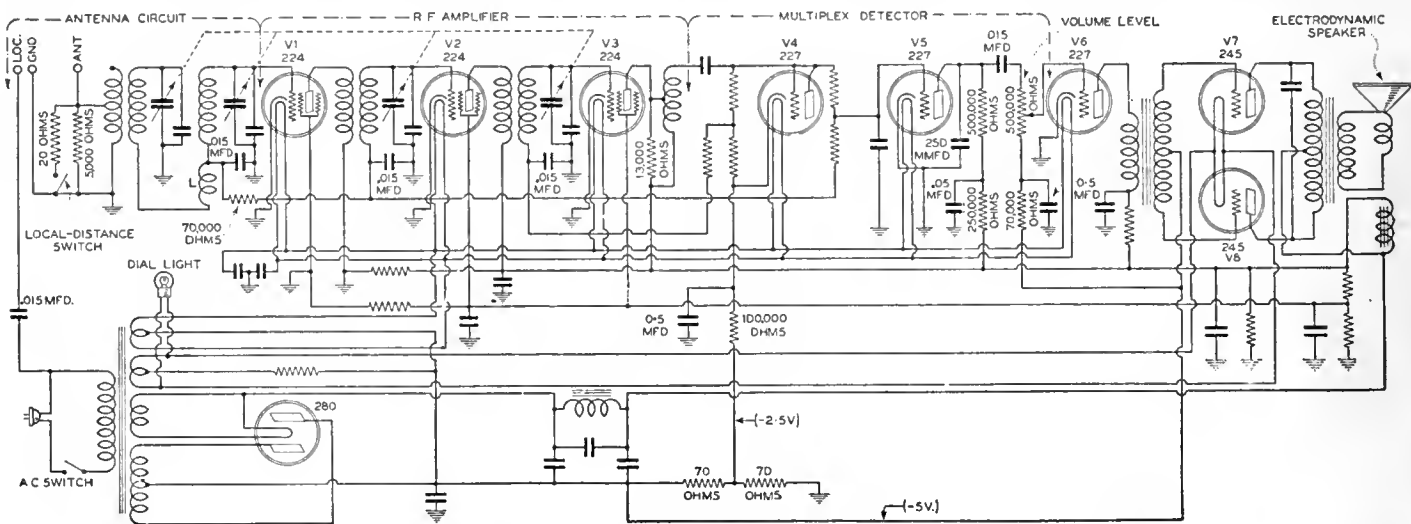

Fig. 1—Complete schematic diagram of the Philco 95 receiver.

THE ELECTRODYNAMIC LOUD SPEAKER

By EDWIN A. UEHLING

THE ELECTRODYNAMIC loud speaker has the unique characteristic of being capable of extremely simple mathematical treatment. It is possible to develop equations which show the importance and the exact nature of nearly every factor that has an influence on the performance of the loud speaker. These equations will be found useful not only in the actual design of loud speakers using the electrodynamic principle, but also as a foundation for experimental research on this type of reproducer.

The equations under discussion are not as complicated as are those which deal with the electromagnetic and some other types of loud speakers because there are fewer variables to consider. The permanent magnetic flux of the field, for example, is invariable, and enters directly into the final equations. The magnetic flux of the signal current is at right angles to this flux, whereas in the electromagnetic type it adds directly to the flux of the field. Saturation problems hardly enter as far as distortion is concerned, and are not at all difficult of solution as far as efficiency is concerned. The flux density of the field enters into the force factor equations as a first power rather than as a second power thus giving us another possible simplification.

The Electrodynamic Principle

The electrodynamic principle is understood to refer to the reaction between a conductor carrying an electric current and a magnetic field in which this conductor is immersed. The electrodynamic loud speaker has these two elements, the conductor and the magnetic field, and a third element consisting of some radiating device for transmitting the mechanical reaction between the conductor carrying the signal current and the electromagnetic field to the surrounding air.

First of all it will be necessary to understand the importance of all factors which have a bearing on the efficiency of the loud speaker. In this connection it should be pointed out that the efficiency of a loud speaker is understood to refer to the ratio of the actual power delivered to the armature, represented by the product of the square of the signal current and the motional resistance, and the electrical power delivered to the loud speaker. Thus we leave out of consideration, temporarily, any loss of energy which may exist in the system between the armature and the surrounding air. This loss of energy may or may not be considerable, depending on the design of the radiating system, which will be discussed later. This is a problem belonging to the mechanical system itself, and, with the exception of the term representing the actual mechanical impedance, need not be considered in the development of the equations for the efficiency of conversion of electrical into mechanical energy.

The electrodynamic unit may be considered as a motor which converts the energy of electric currents into mechanical energy, and in so doing develops a counter e.m.f. that is easily calculated, and upon which a complete understanding of the

performance of the loud speaker quite largely depends.

The e.m.f. generated in a conductor which is cutting lines of force is equal to—

$$e_c = \frac{d\phi}{dt} \cdot 10^{-8} \quad (1)$$

Now the rate at which the conductor in the moving-coil system of an electrodynamic unit cuts the lines of force of a magnetic field threading through this coil is equal to the product of the length of the conductor in centimeters, the velocity of the conductor in centimeters, and the flux density of the field. Then—

$$e_c = \frac{d\phi}{dt} \cdot 10^{-8} \quad (2)$$

$$= l v B \cdot 10^{-8} \quad (3)$$

The velocity of the moving coil is given as the ratio of the force imparted to the coil and the complex mechanical impedance. Then—

$$v = \frac{F}{Z_m \angle \alpha} \quad (4)$$

$$e_c = \frac{F}{Z_m \angle \alpha} l B \cdot 10^{-8} \quad (5)$$

The force in dynes given to the moving coil is equal to the product of the length of the conductor, the current passing through it in c.g.s. units, and the flux density.

$$F = I C B \quad (6)$$

$$= l I B \sin \theta \cdot 10^{-1} \quad (7)$$

then
$$e_c = \frac{l I B \sin \theta \cdot 10^{-1}}{Z_m \angle \alpha} l B \cdot 10^{-8} \quad (8)$$

$$= \frac{l^2 B^2 \cdot 10^{-9}}{Z_m \angle \alpha} \sin \theta \quad (9)$$

Then the resistance due to the counter e.m.f. is

$$R_c = \frac{l^2 B^2 \cdot 10^{-9}}{Z_m \angle \alpha} \quad (10)$$

If R_1 is the d.c. resistance of the coil, or more exactly the clamped apparent resistance of the coil, and L_1 is the apparent clamped inductance of the coil under its conditions of use, the total electrical impedance is—

$$Z_e = R_c + R_1 + j\omega L_1 \quad (11)$$

$$= \sqrt{(R_c + R_1)^2 + \omega^2 L_1^2} \quad (12)$$

$$= \left[\frac{l^2 B^2 \cdot 10^{-9}}{Z_m^2 \angle \alpha^2} + R_1 \right] + j\omega L_1 \quad (13)$$

Let

$$Z_m \angle \alpha = a + jb \quad (14)$$

where

a = mechanical resistance of system
b = mechanical reactance of system

then

$$Z_e = \left[\frac{l^2 B^2 \cdot 10^{-9}}{a + jb} + R_1 \right] + j\omega L_1 \quad (15)$$

$$= \left[\frac{l^2 B^2 (a - jb) \cdot 10^{-9}}{Z_m^2} + R_1 \right] + j\omega L_1 \quad (16)$$

$$= \left[\frac{a l^2 B^2 \cdot 10^{-9}}{Z_m^2} + R_1 \right] + j \left[\omega L_1 - \frac{b l^2 B^2 \cdot 10^{-9}}{Z_m^2} \right] \quad (17)$$

This equation shows that for frequencies below the resonant frequency of the mechanical system, where b is negative, the apparent or free reactance is greater than the actual or clamped reactance, and that the apparent resistance is always larger than the actual resistance. The importance of the term in the first bracket,

the real term of Z_e , will be shown. Let us note in passing that the motional resistance which is equal to—

$$R_m = \frac{a l^2 B^2 \cdot 10^{-9}}{Z_m^2} \quad (18)$$

is never negative as in some other types of loud speakers. However, this fact might have been established without considering these equations. The force, the signal current, and the flux due to the signal current are all practically in the same phase; whereas, in the electromagnetic type of loud speaker, for example, the flux due to the signal current, and therefore the force, lags the current by the hysteresis and the eddy-current angle.

The efficiency of conversion of electrical to mechanical energy is now easily determined. The actual power delivered to the moving system is equal to

$$W = I^2 R_m \quad (19)$$

where I is the signal current in the conductor of the moving coil, and R_m is the motional resistance. But—

$$I = \frac{\mu E_g}{\sqrt{(R + R_p)^2 + X^2}} \quad (20)$$

where

$$R = R_m + R_1 \quad (21)$$

R_p is the plate resistance and

$$X = j \left[\omega L_1 - \frac{b l^2 B^2 \cdot 10^{-9}}{Z_m^2} \right] \quad (22)$$

then

$$W = \frac{\mu^2 E_g^2 R_m}{(R + R_p)^2 + X^2} \quad (23)$$

Now the power input to the moving coil is:

$$W_1 = E I \cos \theta \quad (24)$$

$$= \frac{\mu E_g \sqrt{R^2 + X^2}}{\sqrt{(R + R_p)^2 + X^2}} \mu E_g$$

$$= \frac{\mu E_g}{\sqrt{(R + R_p)^2 + X^2}} \cdot \frac{R}{\sqrt{R^2 + X^2}} \quad (25)$$

$$= \frac{\mu^2 E_g^2 R}{(R + R_p)^2 + X^2} \quad (26)$$

Then the efficiency E is

$$E = \frac{W}{W_1} \quad (27)$$

$$= \frac{\mu^2 E_g^2 R_m}{(R + R_p)^2 + X^2}$$

$$\frac{(R + R_p)^2 + X^2}{\mu^2 E_g^2 R} \quad (28)$$

$$= \frac{R_m}{R} = \frac{R_m}{R_m + R_1} \quad (30)$$

We will substitute for R_m and R their values as given in the equation for Z_e

then

$$E = \frac{a l^2 B^2 \cdot 10^{-9}}{Z_m^2} \cdot \frac{1}{\left[\frac{a l^2 B^2 \cdot 10^{-9}}{Z_m^2} + R_1 \right]} \quad (31)$$

$$= \frac{a l^2 B^2 \cdot 10^{-9}}{a l^2 B^2 \cdot 10^{-9} + R_1 Z_m^2} \quad (32)$$

It is then evident that for maximum efficiency the quantity

$$\frac{a l^2 B^2 \cdot 10^{-9}}{Z_m^2}$$

should be as large as possible

There are certain obvious conclusions that can be drawn from the above statement regarding, for example, the quantity B, the quantity Z_m , and the value of a in comparison with the total impedance Z_m ; i.e., the effect of mechanical resonance on the efficiency.

Other Conclusions

There are still other conclusions that may be drawn. In the design of an electrodynamic loud speaker, a very limited proportion of the cross-sectional area of the air gap can be given to the copper comprising the conductor. The air gap spacing is limited by the maximum reluctance permissible in the magnetic circuit for the magneto-motive force available and the flux required. The width of the gap is limited by the requirements of economy in design, for it is only at the air gap that an approach to magnetic saturation in the iron can be permitted. At all other points in the magnetic circuit the cross-sectional area should be considerably larger than at the air gap to avoid saturation in these parts. Thus the maximum amount of iron intended for use in the circuit is one of the limiting factors in determining the maximum width of the air gap. Finally, with an air gap cross-section, or to be more exact, an air gap volume determined by these and other factors to be described later there is a definite maximum volume of copper that can be used for the conductor carrying the signal current. This volume of copper is further reduced by the requirements of spacing between the coil form and the inner and outer pole faces and by the necessary thickness and volume of the coil form or support itself.

With our copper volume limited in this way, there is only one condition left that is variable. That condition is in the choice of wire. For a given volume of copper an increase in the size of the wire used means a decrease in d.c. resistance and a decrease in the number of turns. As a matter of fact, the ratio of the square of the total length of the conductor required to fill a given volume, to the d.c. resistance of the conductor, and therefore to R_1 , is a constant and depends only on this volume.

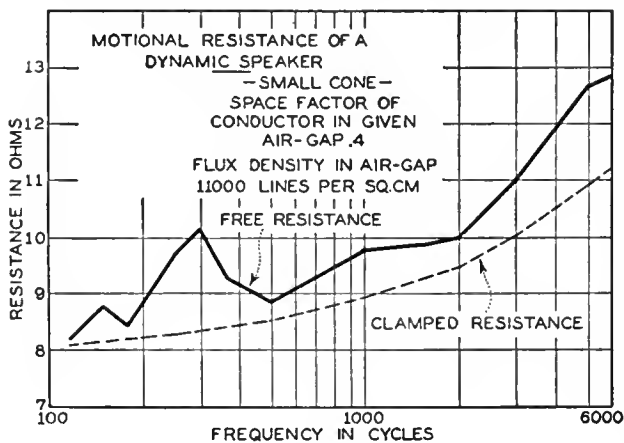

The slight change that there is in the space factor with different sizes of wire is neglected. This ratio being a constant, we learn on further reference to the equation expressing the efficiency that there is nothing to be gained by increasing the length of the conductor. One turn or many turns may therefore be used as desired, provided that a suitable impedance-matching transformer is always used.

Using one turn of heavy copper conductor in the air-gap has the advantage of simplicity, greater space factor, and a greater volume of copper than could otherwise be obtained. Using many turns has

the advantage of greater free resistance with the result that other resistances, such as those of the loud speaker connecting leads, become less important. Many turns also have the advantage of permitting a more desirable mechanical construction. It is not necessary when many turns are used to have the moving system and the entire cone swing about an asymmetrical axis as is so often done in loud speakers using but one turn of heavy copper for the moving coil.

The Electromagnet

The magnetic field of the air gap is usually supplied by means of an electromagnet. This magnet consists in general of a central iron core and an enclosing iron shell with a flat iron cover to complete the circuit and to provide a circular gap. There are many other methods in use. Any construction that minimizes as far as possible the amount of iron required, and yet provides sufficient cross section at all points to carry the flux in the gap as well as the total leakage flux, is good. The metal used should be a good soft grade of steel. Though the reluctance is quite largely localized at the air gap, the reluctance in the iron must be considered as well. Even with good grades of steel tests have shown a marked improvement with annealing, indicating that considerable attention should be given to the iron in the magnetic circuit. If the flux path is cylindrical in shape usually no trouble will be experienced with saturation except at the lower end of the core where it is attached, and at the upper end of the core, where saturation is often permitted in order to reduce leakage flux from the core to the cover across the air gap. However, saturation should not be permitted except at the pole faces. Even with an increase in the leakage flux obtained when the cross section of the core is increased near the upper end, there may be an increase in the flux density as well. At the lower end of the core an additional iron plate that has a diameter somewhat less than that of the cylinder of the electromagnet itself should be used to avoid saturation in this region. Finally, all butt joints should be as close as possible to eliminate added reluctance.

Due to the high leakage flux that always exists it is impossible to determine with great accuracy the flux density that a given set of conditions will provide. One example of how large this leakage flux was is typical of many such designs. In this particular case the total flux passing through the lower end of the core was 72,000 lines. The number of lines of force in the air gap, measured across the actual geometric width of the gap, was less than 45,000. Fringing directly beneath the gap there were about 15,000 lines, and directly above the gap there were about 11,000 lines.

With a knowledge of these conditions it is possible to make use of magnetic circuit equations, allowing for the leakage flux in the calculation. It will be assumed that

good iron is used throughout the magnetic circuit. The reluctance of the circuit is then very nearly—

$$R = \frac{l}{A} \tag{33}$$

where l is the length of the air gap in centimeters, and A is its area in the same unit squared.

A satisfactory flux density in the air gap is about 12,000 lines per square centimeter. A higher flux density may be desired but can be obtained only by increasing the cost. The first named figure, however, is very often the highest that can be obtained economically in an air gap of conventional design. The product of the flux density and the area of the air gap gives us the total flux in the gap.

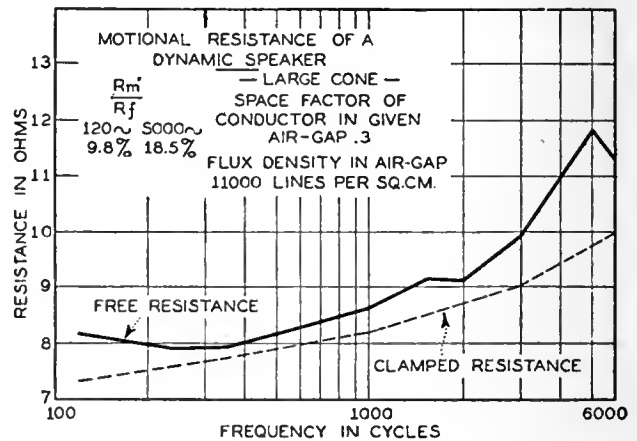

Then, taking the product of the flux and the air gap reluctance, we obtain the magneto-motive force in gilberts required to force this flux through the gap.

$$MMF = \Phi \cdot R \text{ gilberts} \tag{34}$$

$$= .4\pi NI \tag{35}$$

then

$$NI = \frac{\Phi R}{.4\pi} \text{ ampere turns} \tag{36}$$

When the value of the required ampere turns is known the coil of the electromagnet can be designed according to well-known principles. The value of N will depend on the nature of the source of current. If the coil is to be used as a filter choke coil of a power supply system, N will be very large and may amount to 20,000 or 40,000 turns. Under these conditions the voltage drop in the coil will usually be made as large as the supply will permit; i.e., all of the surplus voltage is used to supply the field. This is necessary to permit the use of wire as small as possible. The smaller the size of wire used, the smaller the field coil and the associated magnetic circuit will be. In most practical cases the limit to any great reduction in the size of the wire depends upon the maximum value of the d.c. voltage available. Other limiting factors are the difficulty of winding small sizes of wire, and the maximum permissible power dissipation in the coil. The latter factor is in many practical cases the controlling one, especially when the loud speaker is intended for use in a small cabinet in which there is not much air circulation. In general, this power dissipation for coils and iron containers of the size now in commercial use can be as much as twelve to twenty watts.

Reference has been made to the high value of leakage flux usually present in magnetic circuits of this type. This flux should be estimated on the basis of experience and added to the useful flux of the air gap whenever the flux carrying capacity of the constricted portions of the

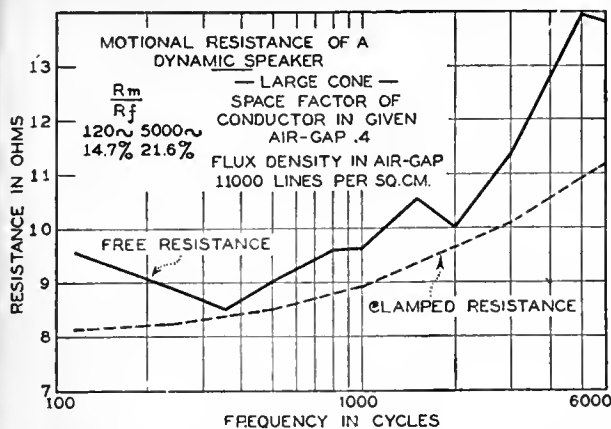

magnetic circuit is considered. It does not, however, enter into the calculation of the M.M.F. to any large extent, because it forms a parallel flux path to that of the useful magnetic flux, which, therefore, has its own magnetic flux-reluctance drop around the circuit as in electrical circuits.

Sound Radiating Device

We will now give some consideration to the sound-radiating device. This usually consists of a paper cone supported around its periphery and attached directly to the coil form. Our equation for efficiency shows that Z_m , the mechanical impedance, should be made as small as possible to give a high ratio of conversion of electrical to mechanical energy. This energy must, however, be radiated, and a small diaphragm, having a lower acoustic impedance than a large diaphragm is not capable of radiating energy to the air as efficiently as the latter. Of the two transformations of the energy resident in the signal current, the latter (the mechanical to acoustical transformation) is by no means the least important. Increasing the size of the radiating member will increase the value of Z_m over most of the frequency range, and thereby reduce the efficiency of the transformation of electrical to mechanical energy; but an increase in the efficiency of the transformation of mechanical to acoustic energy will be obtained, and the resultant overall efficiency will not be altered greatly.

The design of the radiating member has a very direct bearing on the quality of reproduction. There will be present several resonant frequencies having various degrees of damping. The number of these frequencies and the resistance factor involved can be altered materially in the design. Increasing the size of the cone increases the length of the path that the wave energy must travel. There are two principal consequences. The resonant frequencies are lowered, and many that would otherwise be important are placed below the lowest frequency to which the ear is sensitive. The remaining resonant frequencies are materially damped by the increase in the length of the path which the wave motion must follow.

Large Cone Best

For these reasons the large cone is usually capable of better quality of reproduction than the small cone. The fact that it also gives better low-frequency response need not be emphasized, though, it is true, that the amplitude of vibration of which the electrodynamic loud speaker is capable is so large in comparison with the maximum amplitude of vibration

meter of twelve to sixteen inches gives entirely satisfactory results. Increasing the diameter above these values does not usually produce a corresponding increment in quality improvement. On the other hand, further increase in the size of the cone does add considerably to the cost and inconvenience in the mechanical construction of the loud speaker.

Among the most important of all the design features of paper cones is the value of the interior angle at the apex. It is obvious that a relatively small angle tends toward greater stiffness, a better approximation to plunger action, and

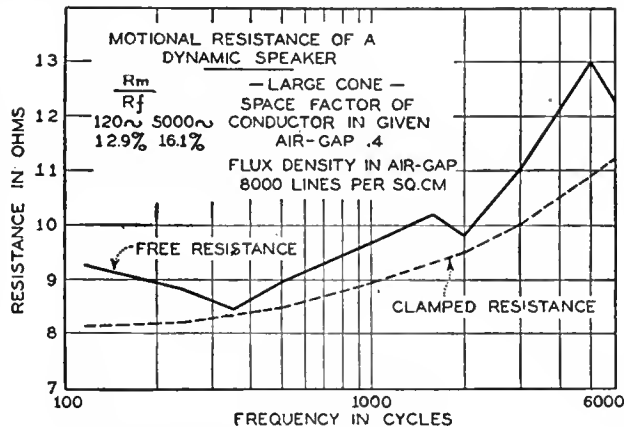

perhaps greater efficiency. Nevertheless it also tends toward the introduction of numerous resonant frequencies, at least one of which may predominate in the reproduction above all other audio frequencies. A relatively large angle tends toward more uniform wave motion at all frequencies, lower and fewer resonant frequencies, especially if the diameter is large, and perhaps reduced efficiency. In most cases this angle must be determined experimentally, and will depend on the material used, the size of the cone, and on the method of measuring or judging the relative characteristics.

If the final design depends on actual measurements the interior angle will probably be made relatively large. If it depends instead on listening tests, the angle will usually be made relatively small, for the ear is often deceived in such tests, and is inclined to favor reproduction that has at least one resonant frequency conveniently placed in the lower-frequency spectrum so as to hide certain faults in the reproduc-

tion, and to lend a greater warmth of color than is present in the original transmission. The tendency now is toward more faithful reproduction of the original, and there is consequently a trend from small angle cones to the large angle or more shallow types. A second trend which is toward the larger diameter is also current. These tendencies may culminate in a more or less general design of cone having a diameter of at least twelve inches and a value for the interior angle at the apex of approximately 140°. Actual acoustic measurements show that such a design is good, and that it has, at least, no decided superiors, providing that a good grade of paper or other material is used.

tion, and to lend a greater warmth of color than is present in the original transmission. The tendency now is toward more faithful reproduction of the original, and there is consequently a trend from small angle cones to the large angle or more shallow types. A second trend which is toward the larger diameter is also current. These tendencies may culminate in a more or less general design of cone having a diameter of at least twelve inches and a value for the interior angle at the apex of approximately 140°. Actual acoustic measurements show that such a design is good, and that it has, at least, no decided superiors, providing that a good grade of paper or other material is used.

Material Used in Cone

The material of which the cone is made has a very decided influence on its acoustic performance. It is essential that the material be relatively non-resonant; i.e., one having a high molecular resistance. Though materials of this kind do not give the maximum in efficiency they are far superior in other respects. The property of non-resonance belongs to materials of this kind by virtue of their texture, which is more or less porous and fibrous. Other materials having the same property are made up of interwoven strands.

Before leaving the subject of materials something should be said regarding their weight and thickness. It is important, of course, that all moving masses be as low in value as it is possible to make them. It is also true that the weight of the cone makes up a large percentage of the total mass. But in most cases satisfactory quality of reproduction does not permit the use of extremely light weight material. The choice of the material should rest on the results of experimental tests.

The design of loud speakers is most rapid and successful when every step is carefully checked and tested in the laboratory. The very nature of acoustic problems, the psychological element involved, and the many interpretations that may be placed on the data obtained in the laboratory call for very careful and consistent experimental work. It is probable that some of the principles discussed here may be useful in aiding continued experimental work on the electrodynamic loud speaker, which, in spite of certain limitations, is perhaps the most faithful in signal reproduction of all the types of sound reproducers. There is, furthermore, little doubt that it is capable of still further improvement and refinements, and this, it is hoped, the continued work of many engineers will give to it.

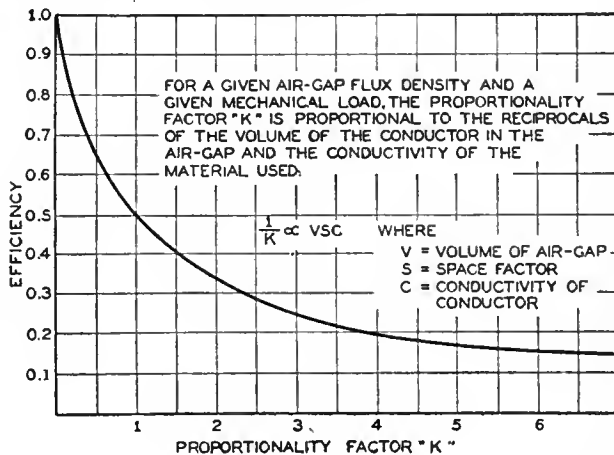

DEVELOPMENT OF THE PENTODE TUBE

BY FRIEDRICH OSKAR ROTHY

Chief Engineer, Philips Radioröhren, G. m. b. H., Vienna

IT is necessary that the output tube of a modern radio receiver furnish considerable power to the load into which it works—the loud speaker. It is also desirable that considerable amplification take place in this tube. However, usual tubes deliver the power at the expense of amplification, because they are almost invariably of the low- μ , low-resistance type.

By the construction of three-grid tubes in Europe (Philips B-443) with very great spacing, it has been found possible to raise the μ to 100, and to maintain the power output at a high level. In other words, the use of three grids makes possible the construction of a power tube with high output and high amplification.

It is well known that due to the electron emission from the filament a space charge of a cloud of negative electrons is formed. These negative charges make it more difficult for the other electrons to leave the filament, and in addition they apparently reduce the plate voltage by their own potential.

Although this so-called space charge can be overcome by increasing the plate voltage, practically there is a limit, in the case of receiving tubes, beyond which this can not be done.

The Second Grid

It is a relatively recent discovery that the space charge can be reduced by introducing a second grid into the tube. This principle is employed in the construction of the normal double-grid (space grid) tube. In this case it is possible to reduce the plate voltage greatly and still have normal plate current. (See Fig. 1.) The auxiliary grid of this double-grid tube is placed between the cathode and the exciting grid, and the positive voltage applied to it is sufficiently high to reduce the space-charge effect.

A second difficulty encountered in the construction of radio tubes is the so-called plate-reflex effect. This limits the maximum undistorted energy that a tube can give. Considering the effects of space charge, with a constant filament temperature, the emission is a function of the filament voltage. Assuming a resistance

load in the plate circuit, which at the same time does not have any direct-current resistance, such as would be the case in an anti-resonant circuit, it is obvious that the plate voltage is the same as the battery voltage only so long as there is no alternating voltage on the grid. Therefore, we must understand that the plate voltage is the real voltage produced between the plate and filament, which is less than the battery voltage, as shown in Fig. 2. If the grid goes more positive, the plate current increases and there is a drop in the external resistance, R_a , due to this increase. This opposes the plate voltage, so that the voltage on the plate is no longer equal to the battery voltage. Similar effects are present when the grid is made more negative.

The reflex action of the plate which is described above naturally causes a decrease in the swing of the plate current. This is the reason for the often repeated rule governing the use of tubes in practical circuits which states that the tube does not work on the same characteristic curve when it is loaded as when it is worked into a short-circuit. In other words, the dynamic characteristic is not the same as the static.

Reducing Plate-Reflex Effect

Inasmuch as the dynamic characteristic always shows a smaller slope than the static, it is necessary to know this characteristic of the tube when worked under average conditions. There is a second requirement, therefore, in the construction of a radio tube, i.e., to reduce the plate-reflex effect, so that the dynamic characteristic may be as near to the static as possible. With such a tube considerable output can be obtained with a value of alternating grid voltage that produces only a small amount of power from a conventional tube.

If now, in accordance with Fig. 3, a second grid is inserted between the normal exciting grid and the plate, and a positive voltage is applied to it, the plate-reflex effect is compensated to a greater or lesser extent. This second grid will have a constant positive potential with respect to the filament irrespective of the external resistance, R_a . Also, if a voltage drop is experienced in the plate circuit, due to the effect of the second grid, the effective voltage will not be reduced.

Under these conditions it is obvious that from time to time the auxiliary grid will be at a higher positive potential than the plate. This fact can cause a phenomenon which may be described as follows. It is well known that secondary electrons can be produced by bombardment of the plate. The bombardment usually, as in the case of transmitting tubes, merely produces heat at the plate. However, the dissipation of the energy produces the second phenomenon of secondary electrons. In the usual tubes, they merely fall back on the plate, since the field is directed only towards the anode. In the

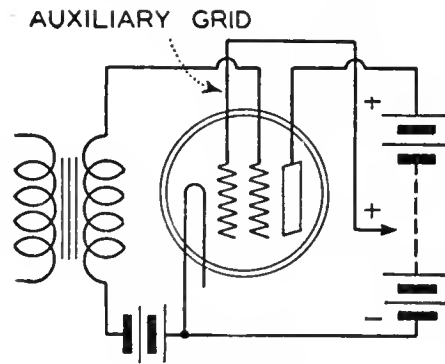

Fig. 1

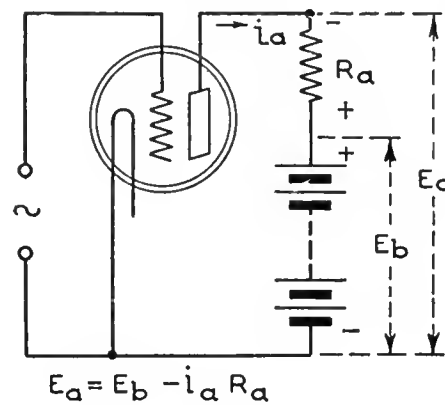

Fig. 2

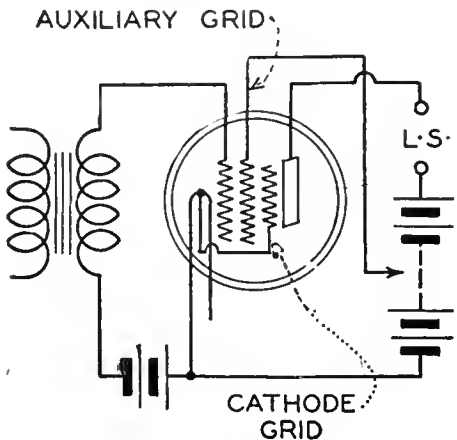

Fig. 3

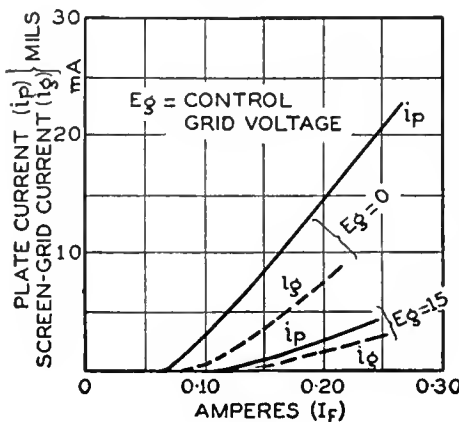

Fig. 4

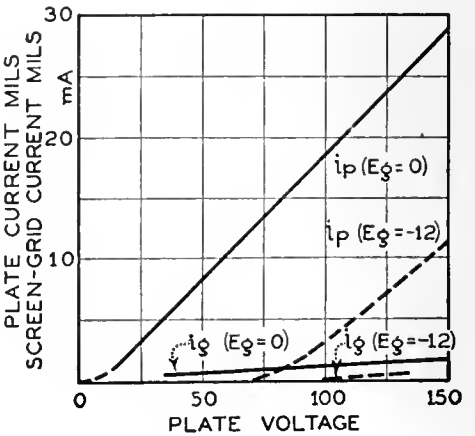

Fig. 5

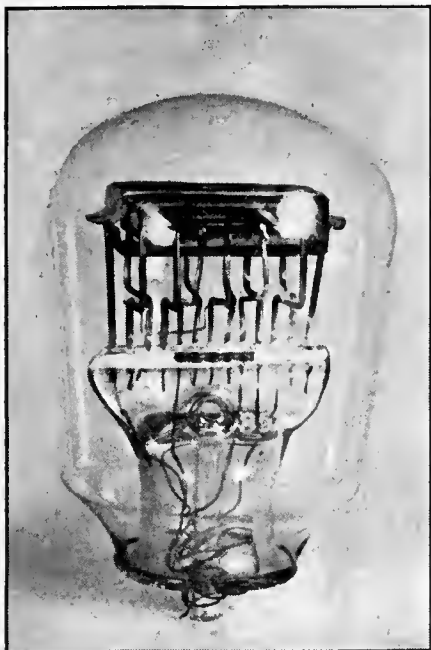

Fig. 6

voltage is less than the auxiliary grid voltage. This can be done by the insertion of a third grid, the so-called cathode grid. This is put in between the plate and the auxiliary grid and, has a somewhat lower potential. Therefore, the secondary electrons find themselves in a field directed towards the plate, since they prefer to go to the plate rather than to the cathode grid with its lower potential. As a result, the secondary electrons fall back into the plate and do not affect the operation.

A very interesting feature of the three-grid tube is the apparent improvement of reproduction at the higher frequencies. The high internal resistance, about 50,000 ohms, can be neglected in comparison with the resistance of the loud speaker at the higher frequencies. The loud speaker, of course, has a dropping frequency characteristic at the upper end of the audio range. The three-grid tube, due to its higher internal resistance, is the only tube which tends to give better reproduction of the higher frequencies and therefore a more even result over the whole range. Practically this is of no advantage, since usually the bass is preferred in a loud speaker, as is the case in an electrodynamic type. In the use of electrodynamic loud speakers, however, the three-grid tube has an advantage due to the more natural reproduction.

[It must be remembered that the author is speaking from the Continental viewpoint when he discusses fidelity of

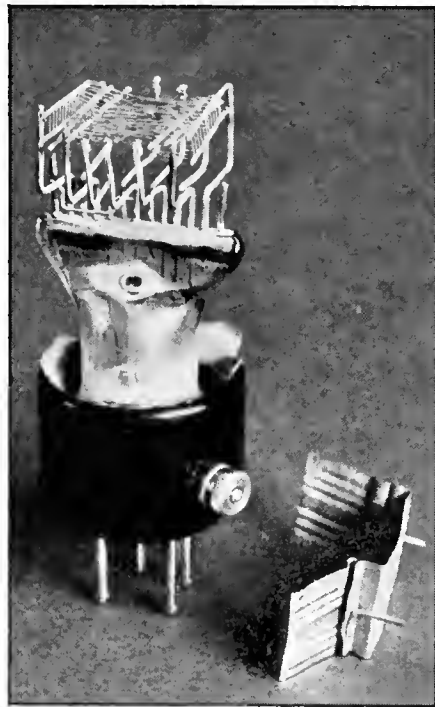

Fig. 7

practical case, therefore, there will be no effect due to the secondary electrons aside from the heating of the plate, as long as the plate is at the highest potential. And this is actually the case in the usual uses of the tube.

In measurements where a higher voltage is impressed on the grid to carry the characteristics beyond the usual range, it is found that after the saturation current is reached, the emission is no longer constant but greatly increases with higher positive plate voltages. In this case, the electrons wander from the plate to the grid and, as a result, are in the opposite direction to that of the normal emission of the filament. They therefore subtract from it and give the apparent effect that the plate current decreases. The secondary emission comes into the question, then, whenever there is another electrode in the tube which has a positive voltage applied to it. In the double-grid tube, due to the external voltage drop, the plate frequently has a lower voltage than the auxiliary grid. In this case, the secondary electrons will travel to the point of higher potential—that is, to the auxiliary grid—and as a result, in the upper part of the emission curve the functioning of the tube will be affected.

A means must be devised to take care of these secondary electrons when the plate

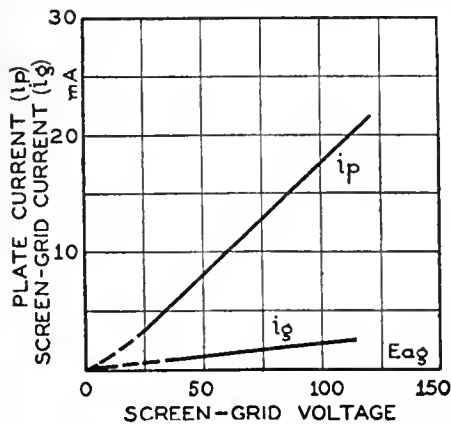

Fig. 8

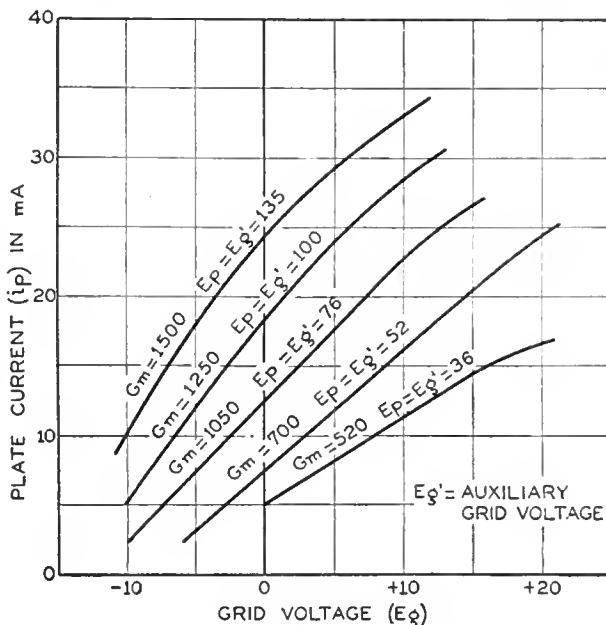

Fig. 10

production. Of course, it is possible to "match" any tube to any load with the proper transformer and thereby secure the desired characteristics.—*The Editor*

Measurements

In the following paragraphs are the results of our measurements on a three-grid tube of the type described. A tube was connected as it is usually used in present loud speaker practice (See Fig. 3). The internal construction of this tube is shown in Figs. 6 and 7.

Fig. 4 shows the relation between filament current and emission for a grid voltage $E_g=0$ and $E_g=-15$, as well as (i_s) between filament current and screen-grid voltage (i_g). It will be noted that the value of the screen-grid current is about 16 per cent. of the total load current from the plate current source. These curves correspond to the normal temperature

emission curves; the screen grid can be considered as a part of the plate.

Fig. 5 shows the relation between plate voltage and emission to the screen grid and plate for two different grid voltages. In this case also, the screen grid takes about 16 per cent. of the load current. The measurements were carried only as high as 150 volts and at this voltage the saturation point had not yet been reached. Filament temperature was constant in these measurements, and the auxiliary grid was at the same potential as the plate.

In the measurements of Fig. 8, the auxiliary grid voltage was varied and the plate voltage held constant at 135 volts. The emission and auxiliary grid current increase rapidly with increase of the auxiliary grid voltage. This voltage should therefore be as high as possible, even higher than the plate voltage itself. Even the slope of the characteristic depends to a large extent on the auxiliary grid voltage. It increases, as shown in Fig. 9, with an increase in the auxiliary grid voltage. The plate voltage was held constant at 135. The curve in Fig. 10 was derived on the assumption of a normal characteristic for the different values of the auxiliary grid

voltage. It can be seen that not only the emission but the steepness decreases with decreasing plate voltages.

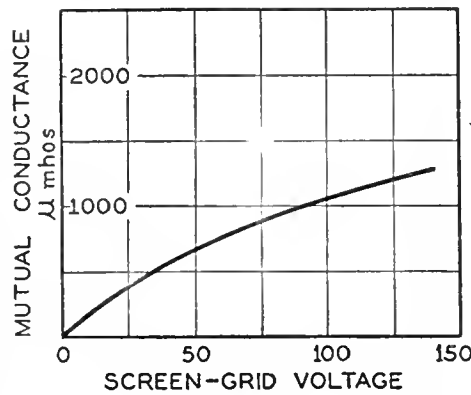
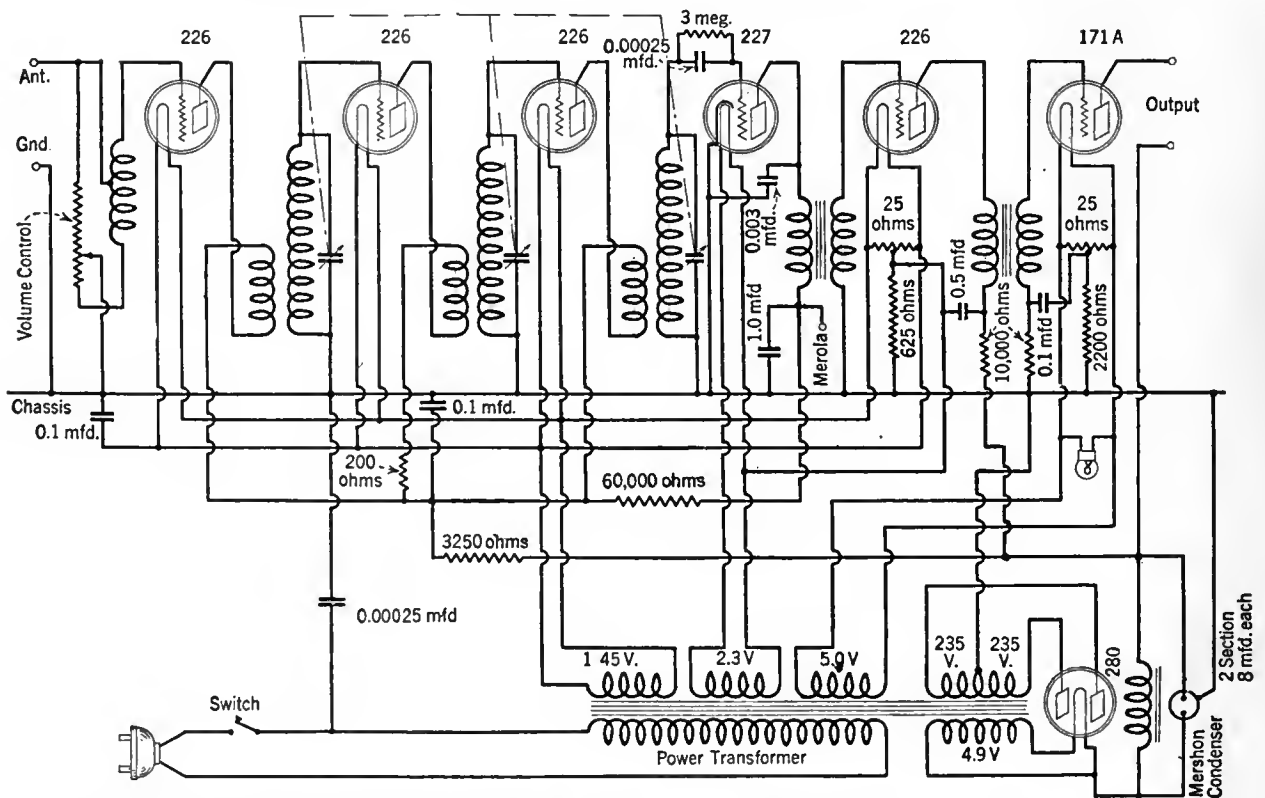

Fig. 9

CROSLY GEMCHEST MODELS 609 AND 610



This is a conventional tuned radio-frequency receiver using a grid-leak-condenser detector and two stages of audio-frequency amplification. The output tube is a single type 171A. Plate voltage

is obtained from a 280-type full-wave rectifier the output of which is filtered by a choke in combination with a Mershon condenser. The volume control is a variable resistor across the antenna circuit.

DAY-FAN MODEL 5091 RADIO RECEIVER

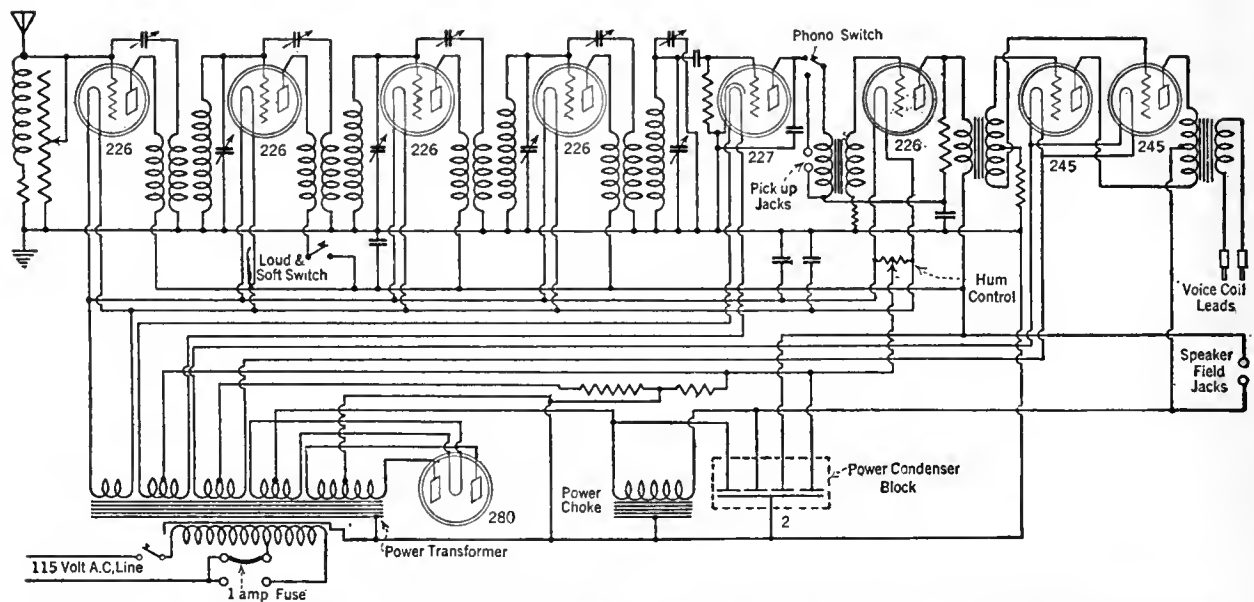

This Day-Fan receiver incorporates four balanced tuned stages of radio-frequency amplification, a semi-tuned input system, detector, one stage of straight audio-frequency amplification, and one

stage of push-pull audio-frequency amplification. In the output are two 245-type tubes. Power for the electrodynamic loud speaker field is obtained from the filter system.

TRIAD Insured RADIO TUBES



Ask for the tube in the black and yellow "Triangular box"

Unlimited
POWER
without
Distortion.

TRIAD INSURED RADIO TUBES are manufactured in a plant equipped with the most modern machinery known. The technical skill and special processes which produce TRIAD Tubes allow unlimited power that retains all the truth and beauty of the original tone. When a tube combines such a feature with a printed certificate guaranteeing a minimum of six months' perfect service, it must be good—tube purchasers realize it. That's why dealers are enjoying greater profits with TRIADS than they have ever experienced before.

Tune in on the TRIADORS every Friday evening, 8 to 8:30 (Eastern Standard Time) over WJZ and associated NBC Stations.

TRIAD MFG. CO., Inc.
Pawtucket, R. I.

TRIAD INSURED RADIO TUBES



AmerTran De Luxe Audio Transformer—List Price \$10.00. Type 151—Between one input and two output tubes—List Price \$15.00



Type AF-8 Audio Transformer—Either 1st or 2nd stage audio—Turn ratio 3½—List Price \$6.00

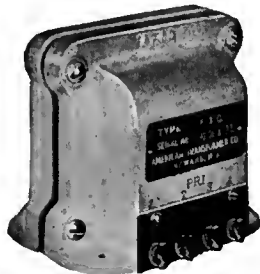

Type 710 Audio Transformer—Between two input and two output tubes—List Price \$20.00



AmerTran Power Transformer—Type PF-245A—List Price \$22.00



Bring the Studio to your Home

There is no excuse for imperfect radio reception. But even today, receiving sets fail to reproduce music and the speaking voice in true tone identical with the range of pitch and the rich fulness of sound quality as broadcast in the studio.

The weak point in most receiving sets is in the audio system.

AmerTran Audio Transformers and Power Transformers shown here perfect the audio system and bring the programs into your home exactly as they go over the air through the microphone. For further descriptions of these and thirty-odd products in the field of radio reproduction that have attained the perfection necessary to AmerTran Standard of Excellence, write for Bulletin 1065.

The facilities of our engineering department are at the service of everyone interested in better radio reproduction.

AMERTRAN

TRADE MARK REG. U.S. PAT. OFF.

QUALITY RADIO PRODUCTS
AMERICAN TRANSFORMER COMPANY
Transformer builders for over 29 years

178 EMMET STREET, NEWARK, N. J.

AMERICAN TRANSFORMER CO.
178 Emmet St., Newark, N. J.

RB-12-9

Please send me Bulletin 1065 containing complete information on AmerTran Transformers, for better radio reception.

Name

Address

Frequency-Band Requirements

ON SHEET No. 308 is reproduced a chart taken from an article by B. S. Cohen in the March, 1928, *Proceedings of the Institute of Electrical Engineers*, London. The chart shows eleven octaves of sounds. According to this chart we find that the

- (a) Ideal frequency range for perfect speech and music and most noises is 30 to 10,000 cycles
- (b) Reproduction of high-quality speech and music requires a frequency band from 100 to 5000 cycles
- (c) Reproduction of good quality articulate speech requires a frequency band from 200 to 3000 cycles

Considering the reproduction of music, on reference to the chart it will be noted that the highest note of the organ, C⁸, has a frequency of 8000 cycles so that if the ideal band extends to 10,000 cycles little or no deviation from a sinusoidal wave form would be included. However, the extreme upper notes of the organ or piano are used very infrequently and the correct reproduction of their timbre is probably not important. It is doubtful whether many persons could differentiate between say a piano,

flute, and clarinet when listening only to the signal note C⁸.

Although in the case of speech, the ear will reconstruct the fundamental frequency of a tone when the latter has been removed from the reproduction it is doubtful that the same thing applies in the case of music. In any case the practically pure sinusoidal frequencies produced for example by the organ would not be produced at all if below the lower transmission limit.

For the correct reproduction of noises such as tapping, hissing, etc. a very wide frequency range is required and it is in this connection that the ideal range of 30 to 10,000 cycles would probably be found most essential.

Attention should be drawn to one other point in the chart. The mean speech frequency from an articulation standpoint is 1500 cycles. By this it is meant that the removal of all frequencies above 1500 cycles produces the same decrease in articulation as does the removal of all frequencies below 1500 cycles.

The term "Gamut" in the chart on sheet No. 308 is simply the expression used in music for the standard notes of the musical scale.

SETTING RADIO STANDARDS

(Continued from page 110)

to oscillate. The same type of data regarding overloading, quality, selectivity, etc., might be given, but is of detailed interest only for specific cases.

The question as to what the limits should be in a radio receiver cannot be simply answered by stating that sensitivities should be permitted to vary 50 per cent. or that the 60-cycle response must be between 60 and 70 per cent. of that at 400 cycles. Each individual receiver should be made to order following company policies and the standards of the class of units chosen as a relative standard. It has a right to its own reasons for its limits—no group can arbitrarily decide what certain percentage variations in receiver performance are permissible. A high priced set might have close limits, while a change in limits and a reduction of price would make the set a greater profit maker and a better seller. What should the limits be? Fig. 3 shows the sensitivity variation of one design which seems to be a fair compromise between cost and performance. For another design and another price another answer might be obtained.

The whole point to this discussion is that having chosen any particular relative standard as a logical performance possibility, it is the manufacturer's duty to stick to that performance standard as close as is economically possible; that his components should be designed with a particular end in view so that they, too, may share in the honor of reducing the cost; and finally that the limits not be set because the units vary that much, but because the limits are set first in accordance with the company policy, and the set is designed accordingly. These are not mere possibilities, they are workable plans and ably carried out will save money for manufacturer and consumer alike.

ADVERTISE WHAT YOU HAVE TO SELL

(Continued from page 89)

produced. The writer wrote advertisements, letters, and folders. One of his letters sold me a suit, so you see he was good. The tailor made so much money that he bought land in the suburbs, decided there was no fundamental difference between cutting up cloth and cutting up ground, and sold his lots by the same principles that had been so successful in tailoring. Now he's so rich that he doesn't care what happens. My friend, now famous, gets no more free suits, and the tailoring business, deprived of its vitalizing advertising force, is back almost where it started.

It all goes to show that advertising pays when it is properly done. Put the big emphasis on that word "properly," and then when you are tempted to tell somebody exactly how he should advertise, ask yourself how you would like a stranger to tell you how you should advertise.

This is not to say that dealers cannot be of some advertising assistance to manufacturers. For example, dealers know a lot about the effectiveness of the local papers. But the dealer should not try to tell the manufacturer how to advertise.

Only two people are qualified to prepare successful advertising. One is the advertiser himself. The other is an advertising man who has had the benefit of close personal contact with the business, its executives and its products. Experience proves that this advertising man is the better equipped of the two. Neither of these persons can prepare good advertising for a third. In other words, manufacturers are not qualified to do dealer advertising.

NOTE	CYCLES PER SECOND	ORGAN PIPE	REMARKS
C ⁸	32,768	3 in.	Beyond limit of audibility for average person.
C ⁷	16,384		Telephone silent with 40 volts on receiver terminals.
C ⁶	10,000		Considered ideal upper limit for perfect transmission of speech and music.
	8,192		Highest note on fifteenth stop.
	5,000		Considered as satisfactory upper limit for high quality transmission of speech and music.
C ⁵	4,096		Highest note of pianoforte.
E ⁴	2,560		Approximate resonant point of ear cavity.
G ⁴	3,072		Considered as satisfactory upper limit for good quality transmission of speech.
C ⁴	3,000		
	2,048		
A ²	2,000	Maximum sensitivity of ear.	
	1,500	Mean speech frequency from articulation standpoint.	
	850	Representative frequency telephone currents.	
A ₂ ²	800		
E ₂ ²	600		
A ₁ ¹	426.3		Orchestral tuning. See note below.
C ¹	256		
C ⁰	200	Considered as satisfactory lower limit for good quality transmission of speech.	
	128	Considered as satisfactory lower limit of high quality transmission of speech and music.	
100			
E ₀	80	Lower note of man's average voice.	
C ₀	64	8 ft. Lowest note of 'cello.	
B ₁	60	16 ft. Lowest note of average church organ.	
C ₁	32		
	30		Considered ideal lower limit for perfect transmission of speech and music.
A ₂	27	Lowest note of pianoforte.	
G ₂	25	32 ft. Lowest audible sound. Longest pipe in largest organ.	
C ₂	16		

Notes of the "Gamut"
 Vibration frequencies proportional to
 Intervals between successive notes
 NOTE:- Nearest note is indicated. Scale based on Middle C¹ (Physical Pitch) = 256 ~

C	D	E	F	G	A	B	C
1	9/8	5/4	4/3	3/2	5/3	15/8	2
	9/8	10/9	16/15	9/8	19/18	9/8	15/16

Volume vs. Fidelity

PARTICULARLY when reproducing music, the volume of the reception has quite a little to do with the naturalness of the reproduction. The loudness of the sounds influences the fidelity in two ways as explained in the following paragraphs.

In the first place, we should realize that we are accustomed to listen to different types of music—symphonies, jazz, string trios, etc.—at definite levels of volume. If we adjust our set so that the music is not reproduced at a volume of approximately the same level to which we are accustomed, then the reproduction will sound unnatural—in fact, it is unnatural. If we increase the volume so a soloist sounds like an entire orchestra, or decrease the volume so that the boom of the base drum sounds like someone tapping the table with a pencil, we have certainly distorted the original. For most natural reproduction the volume level must appear to the ear to be about the same as the original. The fact that we never increase the volume to such a level because we couldn't

tolerate so much sound in a single room, and because we don't want to annoy our neighbors, does not invalidate the argument.

The second manner in which the reproduction of music at other than normal volume affects the naturalness of the sound is due to the characteristics of the ear. At low volume levels the ear is quite insensitive to high and low audio frequencies but as the volume level is raised the sensitivity of the ear becomes more uniform over the entire range of audio frequencies. The effect of this variation in the characteristic of the ear is such as to cause an apparent loss of low frequencies when the volume is turned down. This probably explains why a loud speaker seems to lose the lows when the volume is turned down—a point about which many experimenters have written us. Probably in almost all cases the loss of lows at low volume is not due to the characteristics of the loud speaker but is simply due, as indicated above, to the characteristics of the ear of the listener.

Wright - De Coster Reproducer

Truly outstanding in purity of tone, volume and fidelity of reproduction is this reproducer.

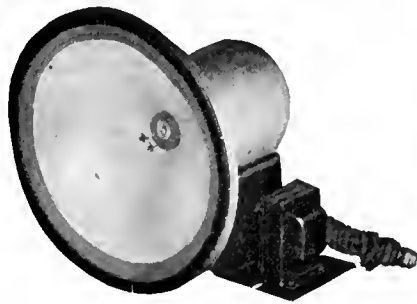

"The Speaker of the Year"

Cabinets De Luxe

A cabinet of exquisite contour, with a delicately carved grill in acorn and oak leaf motif, against a background of figured cloth of silver bearing the same emblematic design. Legs are of spinnet design and can be sold separately if desired. Dealers can carry a more complete, convenient and less expensive stock by purchasing separate units.

Write for Information

You will receive complete information about both the Wright-De-Coster Reproducer and complete line of cabinets.

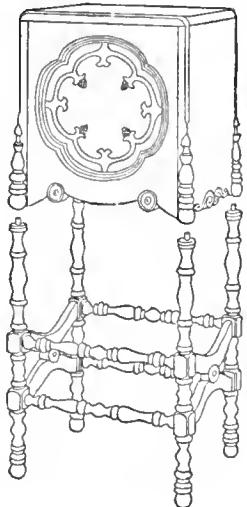

WRIGHT-DECOSTER, Inc., 2213 University Ave.
St. Paul, Minn.

Read what engineers have to say about Rider's "Trouble Shooter's Manual"

RADIO CORPORATION OF
PENNSYLVANIA
331 Fourth Avenue
Pittsburgh, Pa.

August 23, 1929.

Radio Treatise Co.,
1440 Broadway, New York City
Gentlemen:

We have received John F. Rider's "Trouble Shooter's Manual" which our instructors, who are Westinghouse Electric and Manufacturing Company and Radio Corporation of America engineers, recommend highly and say that all of our radiotrician students should have a copy. . . .

Very truly yours,
Radio Corporation of Pennsylvania,
(Signed) W. R. Jones,
Business Manager.

Is a higher recommendation possible? You too, if you are interested in radio and radio service will find Rider's

"TROUBLE SHOOTER'S MANUAL"

of infinite value. Wiring diagrams of more than 200 models of radio receivers . . . Trouble Shooting information. . . How to find the trouble . . . The possible troubles and symptoms in radio frequency amplifiers—detectors—audio frequency amplifiers—A eliminators—B eliminators—a wealth of vital money-making information . . . THE BOOK WILL BE WORTH HUNDREDS OF DOLLARS TO YOU . . . 22 chapters of vital information—the kind of dope you need in your service business . . .

Wiring Diagrams of These Commercial Receivers

- | | |
|----------------------|-------------------|
| Radio Corp. of Amer. | Federal |
| Atwater-Kent | Crosley |
| Zenith | Majestic |
| Fada | Stromberg-Carlson |
| Stewart-Warner | Grebe |
| Philco | Freshman |
| Freed-Eiseman | Kolster |
| All-American | Day-Fan |
| Colonial | Workrite |
| Amrad | Spartan |
| Deforest | Ware |
| Garod | Kennedy |
| Operadio | Sleeper |
| Magnavox | Grimes |

240 PAGES 8 1/2" x 11", BLACK STURDITE
BINDING

RADIO TREATISE CO.
1440 Broadway, New York City

Send No Money

RADIO TREATISE CO.
1440 Broadway, New York City

Send me John F. Rider's "Trouble Shooter's Manual" and I will pay postman \$3.50 plus a few cents for postage on delivery. It is understood that my money will be refunded if I am not entirely satisfied.

Name.....
Address.....
City..... State.....

High Vacuum
"High Vacuum" De Forest
Audions contain less than
1-15th the air pressure of
other standard tubes.

DE FOREST RADIO CO.
NEW JERSEY
JERSEY CITY

de Forest
AUDIONS

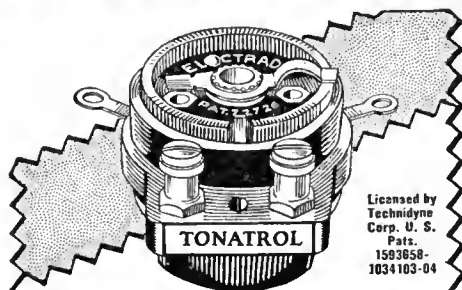

Licensed by
Technidyne
Corp. U. S.
Pat.
1593858-
1034103-04

ELECTRAD TONATROLS

SELL—because BETTER!

SUPERIOR workmanship, smooth performance and longer life, SELL the TONATROL line. Careful design, resulting in maximum efficiency and adaptability **KEEPS THEM SOLD.** Exclusive construction. Contact made *indirectly* with resistance element insuring less wear.

Made in a variety of values for different circuits, with or without filament switch. List \$1.50 to \$3.00.

SUPER-TONATROL

For modern high powered receivers. New type permanent resistance element with pure silver floating contact. Shielded metal construction
List—\$2.40
to \$3.50

175 Varick St., New York, N.Y.
ELECTRAD
INC.

Electrad, Inc., Dept. RB12
175 Varick Street, New York, N. Y.
Send Tonatrol & Super-Tonatrol data.
Name..... Address.....

ELECTROSTATIC LOUD SPEAKERS

(Continued from page 107)

the loud speaker. The size of the holes in the back plate may also affect the shape of these curves. Such mechanical resonances are very important in the design of electrodynamic and magnetic loud speakers, as well as in the design of electrostatic loud speakers. It is only by proportion of the mechanical and electrical resonances that even response can be obtained.

In drawing conclusions from the tests just described, it must be borne in mind that they apply to a particular type of electrostatic loud speaker tested under particular conditions. Although some of the results apply to all types of electrostatic loud speakers, the authors prefer to limit their conclusions to the particular type in hand.

The results of the investigation so far may be summed up as follows:

1. That the greater part of the sound comes from vibration of the diaphragm over the holes, and that this vibration may be increased or decreased by changing the shape of the holes.

2. That harmonic distortion may be reduced by the use of high bias potentials;

3. That the response of this loud speaker is very uneven as compared to a well-designed standard electrodynamic loud speaker.

4. That it would seem that by proper combination of size of holes, size of back plate, and correct design of input circuit, an electrostatic loud speaker of this type can be designed which will give very even response.

5. That this loud speaker in its present stage of development is inferior to the electrodynamic type in evenness of response, general efficiency, and convenience of operation.

6. That while the results obtained in testing this particular loud speaker show that it is inferior to the electrodynamic type, it should not be thought that it is impractical or that it cannot be designed so as to give good reproduction. As a matter of fact, this particular loud speaker performs much better, and gives much more natural reproduction, than the magnetic loud speakers of only one or two years ago, and in addition it has the advantage of distributing its sound much more evenly than many loud speakers now in use.

GENERAL MOTORS—AND RADIO

(Continued from page 71)

It is pointed out that RCA in absorbing Victor, continued the merchandising policies and avenues of distribution of the old company, while maintaining the separate product and merchandising avenues of the Radiola line. Thus far, this policy has apparently not interfered with either complete line.

Charles F. Lawson, president of Day-Fan, the organization absorbed into General Motors Radio Corporation, has announced to his dealers and distributors: "The enormous advantages which General Motors' backing gives to us—manufacturer, distributor, dealer—are obvious. At once, there is the authority of a great name in engineering, research, and manufacturing behind the claim of excellence in our product. There is the distinct advantage of the General Motors Acceptance Corporation plan of financing deferred payments. Looking to the future, the implications of General Motors' entry in the radio field, with its great resources, are tremendous.

"The Day-Fan dealer franchise is a most valuable one to-day. It is potentially the most important franchise in radio."

Those in the industry who have given serious thought to the implications of the General Motors Radio Corporation's entry into the field, feel that it means first, the coming into radio of a new manufacturing company with ample financing and an important history of experience in mass production, secondly, the entry of skilled merchandising experience suggesting many possible innovations, thirdly, the further extension of radio deferred payment sales through the large resources of General Motors Acceptance Corporation, and fourthly, the probable building up of a new distributing group. Radio is already linked closely to sales outlets for refrigerators, automobiles, and automobile accessories, and it is expected that this new company would not confine its dealer outlets exclusively to those now handling Frigidaire on the one hand or automobiles on the other. It is more likely that the distributing set-up will include outlets from each of these major groups and build up a primary set of radio outlets rather than select one complete ready-made dealer group.

HOUSE-TO-HOUSE SELLING IS NOT A SIDELINE

(Continued from page 86)

That's the outstanding reason why there has been so much unfavorable reaction of late against the method on the part of home owners. It is just as important that the man who represents your store on the outside be as courteous, honest, and fair as those behind the counter."

No matter how many door-to-door men he may employ, however, Mr. Green is firm in his opinion that the store should be the dealer's first consideration. Regardless of the future of the outdoor salesman, the store is practically certain to continue as the backbone of the merchandising structure. Then too, the more attractive and better known the store, the more weight that is added to a salesman's visit to a home.

The better the store the better the chances for success in house-to-house selling—and the better the chance to keep abreast of the merchandising trends of the future.

HOW ABOUT TIME PAYMENTS?

(Continued from page 83)

per cent. of their volume, 38 per cent. report cash sales between 5 and 10 per cent. of volume, 16 per cent. have from 10 to 20 per cent. cash sales, only 8.5 per cent. report 20 to 30 per cent. cash sales, 11 per cent. get from 30 to 50 per cent. cash sales, and 4 per cent. of the dealers reporting have as high as 80 per cent. cash sales.

Seriously, I ask, for the good of the business and of those in it, shouldn't those cash sale figures be going up and up? But, I am sorry to say it looks as though they were not, for in answering the next question—"Are cash sales larger than last year?"—30 per cent. of the dealers say "Yes" and 70 per cent. say "No."

I fancy I can see a bright light in the answers to the last question—"What proportion of your sales do you write off as bad debts?" More than one quarter of the dealers—29 per cent.—say "None" and 38 per cent. say 1 per cent. or less. Glory be! Two thirds of the dealers who report say 1 per cent. or less of bad debts. Looks like a fairly good customer-credit situation.

Straws which indicate which way the breeze blows—that's what these reports mean. Something to think about. Suggestions for a change in practice if it is needed. We cannot take these figures as the last word of authority on common practice. Five hundred dealers were questioned, a lot of dealers to be sure, but a

small proportion of the whole. Not all of them answered, of course.

Accuracy of percentage is not the criterion of this questionnaire. More replies might change these percentages, but I'm sure they wouldn't change the broad high lights of the picture, in which I fancy I see these facts.

(a) It is possible and wise to finance installment sales without loss, and even at a profit for financing as well as for selling.

(b) Customers can and should be made to pay a reasonable price for the very great accommodation of time payments.

(c) Down payments may easily be as high as 25 per cent. or even higher.

(d) The cash sales in the industry are too low in proportion to time sales, particularly till the percentage of cash down on time-payment sales is increased.

(e) The showing in bad debts is one of great credit to the industry.

THE JOBBER'S NEW PLACE

(Continued from page 79)

located in non-competitive neighborhoods.

The unsound and uneconomical elements of long terms and credit losses will be practically nil. Equally out of date will be the practice of having eleven jobbers' salesmen all undertaking to sell a quarter of a case of a standard brand of soap or milk to a retailer whose credit is Z-blank.

The independent retailer will have changed his mind about not letting his jobber tell him what to buy and what to sell. He will no longer take the position that he is an independent business man who can go broke any time he wants to and nobody can stop him. Such an individual will have a hard time finding a jobber who will work with him.

In brief, the jobber of 1935 will have practically as close supervision over his retailers as the chain-store management has over its units. The outstanding difference will be that when the contract which the retailer has signed expires, he will be free to sign up with another jobber.

The great difference between the individual retailer of 1935 and the individual retailer of to-day will be that the 1935 model will be in position to merchandise right along with anybody else in his neighborhood.

All in all, it is safe to say that the lot of the individual retailer in 1935 is going to be much happier and more profitable than it is now. The manufacturer of drug sundries, dry-goods products—he'll have a new worry. These combinations of wholesalers and their groups of retailers, buying, selling, merchandising, and advertising as large groups will do some interesting things in the way of pushing private brands.

They'll go just as far in this direction as proves profitable. They will attack in the weakest spots. They will take hold of a kind of product which is not dominated by one or more well-advertised brands which have the popular demand and put back of such items a much more intelligent sales effort than they have thus far been able to provide.

The turmoil and tumult of 1920 to 1930 will have quite definitely subsided by 1935. The spread between the actual cost of the product on the manufacturer's floor and the price paid for it by the ultimate consumer will have shrunk materially.

There will be little difference, so far as the consuming public is concerned, between the individually owned stores and the units belonging to chains, except that the individually owned stores will be in position to exert more latitude, more individualism, be more in tune with their immediate neighborhood than the chain-store unit.

RADIO Isn't Modern Without Automatic VOLTAGE CONTROL

See that the electric radio you buy or build is equipped for the AMPERITE Self-Adjusting LINE VOLTAGE CONTROL. Prevents noisy voltage fluctuations. Improves Reception—Saves Tubes.

Write for Useful Bulletin. Address Dept. RB 12

AMPERITE Corporation
561 BROADWAY, NEW YORK

AMPERITE Self-Adjusting LINE VOLTAGE CONTROL

Why not subscribe to Radio Broadcast? By the year only \$4.00; or two years \$6.00, saving \$2.40. Send direct to Doubleday, Doran & Co., Inc., Garden City, New York.

STATEMENT OF THE OWNERSHIP, MANAGEMENT, CIRCULATION, ETC., required by the Act of Congress of August 24, 1912, of RADIO BROADCAST, published monthly at Garden City, New York, for October 1, 1929. State of New York, County of Nassau.

Before me, a Notary Public in and for the State and County aforesaid, personally appeared John J. Hessian, who, having been duly sworn according to law, deposes and says that he is the treasurer of Doubleday, Doran & Co., Inc., owners of Radio Broadcast and that the following is, to the best of his knowledge and belief, a true statement of the ownership, management (and if a daily paper, the circulation), etc., of the aforesaid publication for the date shown in the above caption, required by the Act of August 24, 1912, embodied in section 411, Postal Laws and Regulations, printed on the reverse of this form, to wit:

1. That the names and addresses of the publisher, editor, managing editor, and business managers are: *Publisher*, Doubleday, Doran & Co., Inc., Garden City, N. Y.; *Editor*, Willis Kingsley Wing, Garden City, N. Y.; *Business Managers*, Doubleday, Doran & Co., Inc., Garden City, N. Y.

2. That the owner is: (If owned by a corporation, its name and address must be stated and also immediately thereunder the names and addresses of stockholders owning or holding one per cent. or more of total amount of stock. If not owned by a corporation, the names and addresses of the individual owners must be given. If owned by a firm, company, or other unincorporated concern, its name and address, as well as those of each individual member, must be given.) F. N. Doubleday, Garden City, N. Y.; Nelson Doubleday, Garden City, N. Y.; George H. Doran, 244 Madison Avenue, N. Y. C.; Russell Doubleday, Garden City, N. Y.; John J. Hessian, Garden City, N. Y.; W. Herbert Eaton, Garden City, N. Y.; Henry L. Jones, 244 Madison Avenue, N. Y. C.; Donald Macdonald, Garden City, N. Y.; Harry E. Maule, Garden City, N. Y.; William J. Neal, Garden City, N. Y.; Daniel W. Nye, Garden City, N. Y.; Reginald T. Townsend, Garden City, N. Y.; Dorothy D. Babcock, Oyster Bay, N. Y.; Alice DeGraff, Oyster Bay, N. Y.; Florence Van Wyck Doubleday, Oyster Bay, N. Y.; Janet M. Doubleday, Glen Cove, N. Y.; S. A. Everitt, Huntington, N. Y.; E. French Strother, Garden City, N. Y.; George H. Doran, Trustee for Mary Noble Doran, 244 Madison Avenue, N. Y. C.; F. N. Doubleday or Russell Doubleday, Trustee for Florence Van Wyck Doubleday, Garden City, N. Y.; S. A. Everitt or John J. Hessian, Trustee for Josephine Everitt, Garden City, N. Y.

3. That the known bondholders, mortgagees, and other security holders owning or holding 1 per cent. or more of total amount of bonds, mortgages, or other securities are: (If there are none, so state.) NONE.

4. That the two paragraphs next above, giving the names of the owners, stockholders, and security holders, if any, contain not only the list of stockholders and security holders as they appear upon the books of the company but also, in cases where the stockholder or security holder appears upon the books of the company as trustee or in any other fiduciary relation, the name of the person or corporation for whom such trustee is acting, is given; also that the said two paragraphs contain statements embracing affiant's full knowledge and belief as to the circumstances and conditions under which stockholders and security holders who do not appear upon the books of the company as trustees, hold stock and securities in a capacity other than that of a bona fide owner; and this affiant has no reason to believe that any other person, association, or corporation has any interest direct or indirect in the said stock, bonds, or other securities than as so stated by him.

(Signed) DOUBLEDAY, DORAN & COMPANY, Inc.
By John J. Hessian, Treasurer.

Sworn to and subscribed before me this 17th day of September, 1929.

[SEAL] (Signed) Frank O'Sullivan
Notary Public Queens County No. 1501
Certificate filed in Nassau County
Term expires March 30, 1930

ACTRON

RADIO TUBES



5 Reasons for Actron's nation-wide popularity

Tone quality

Long life

Uniformity

Non-microphonic

Finest processes of manufacture

Call your Jobber or write us direct for complete ACTRON dealer information.

The ACTRON CORPORATION
123 N. SANGAMON ST.
CHICAGO, ILL.

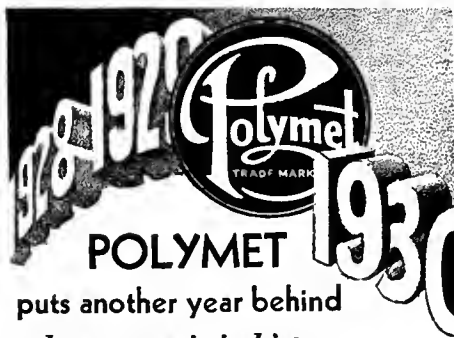

puts another year behind
—the greatest in its history

Over 80% of all the radio manufacturers turned to Polymet in 1929 for standard radio essential parts.

Starting right where 1929 leaves off, Polymet will strive in 1930 to occupy an even more dominating position in the radio parts industry, by continuing to offer the same unapproachable Quality, incomparable Service, and unexampled Dependability in

CONDENSERS
RESISTANCES
COILS

and other

POLYMET PRODUCTS

Polymet Manufacturing Corp.
837 East 134th Street New York City

Here's the Answer

to every question about the principles, methods, or apparatus of radio transmitting and receiving. A Complete Course in Radio Operation in a Single Volume.

THE RADIO MANUAL

A New Edition

Complete new chapters on aircraft radio equipment; Practical Television and Radiomovies with instructions for building a complete outfit; radio interference; 100% modulation; latest equipment of the Western Electric Co.; the Marconi Auto-Alarm System; and many other developments of the past year. All this information is added in the new edition and, besides, the entire book has been brought right up to date with much new material. *The Radio Manual* continues to be the one complete and up-to-the-minute handbook covering the entire radio field.



A Handbook for Students Amateurs Operators Inspectors

20 big chapters cover: Elementary Electricity and Magnetism; Motors and Generators; Storage Batteries and Charging Circuits; The Vacuum Tube; Circuits Employed in Vacuum Tube Transmitters; Modulating Systems and 100% Modulation; Wave-meters; Piezo-Electric Oscillators; Wave Traps; Marine Vacuum Tube Transmitters; Radio Broadcasting Equipment; Arc Transmitters; Spark Transmitters; Commercial Radio Receivers; Marconi Auto-Alarm; Radio Beacons

and Direction Finders; Aircraft Radio Equipment; Practical Television and Radiomovies; Eliminating Radio Interference; Radio Laws and Regulations; Handling and Abstracting Traffic.

An immense amount of information never before available including detailed descriptions of standard equipment is presented.

Prepared by Official Examining Officer

The author, **G. E. Sterling**, is Radio Inspector and Examining Officer, Radio Division, U. S. Dept. of Commerce. The book has been edited in detail by **Robert S. Kruse**, for five years Technical Editor of QST., the Magazine of the American Radio Relay League. Many other experts assisted them.

Free Examination

The new edition of "The Radio Manual" has just been published. Nearly 900 pages, 369 illustrations. Bound in Flexible Fabrikoid. The coupon brings the volume for free examination. If you do not agree that it is the best Radio book you have seen, return it and owe nothing. If you keep it, send the price of \$6.00 within ten days.

Order on This Coupon

D. Van Nostrand Co., Inc.,
250 Fourth Ave., New York

Send me the Revised edition of THE RADIO MANUAL for examination. Within ten days after receipt I will either return the volume or send you \$6.00, the price in full.

(Radio Broadcast 12-29)

Name.....
St. & No. A.....
City and State.....

**A Simplified
"MORECROFT"**

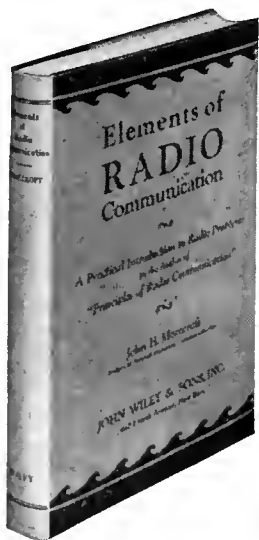

**Elements of
Radio
Communication**

By **JOHN H. MORECROFT**
*Professor of Electrical Engineering,
Columbia University*

For several years Morecroft's "Principles of Radio Communication" has been recognized as the last word on the subject. But as it is highly technical, there have been many suggestions to the effect that a similar but shorter and simplified work would be welcomed by thousands of people.

In response to this, Professor Morecroft has just written "Elements of Radio Communication." It embraces all the major features of the larger work, but it is treated in a much simpler fashion. While technical, it requires no mathematical training further than a knowledge of elementary algebra. The whole field of radio is discussed from broadcasting to receiving, and the latter from a simple crystal set to the most modern A.C. operated receiver. Also, the book is completely illustrated with charts and diagrams, and is supplemented with sets of problems taken from actual radio circuits and apparatus.

Let a free examination convince you that "Elements" furnishes an ideal introduction to radio.

Price \$3.00

A Wiley Book

FREE EXAMINATION COUPON

JOHN WILEY & SONS, Inc.
440 Fourth Avenue, New York

Gentlemen: Kindly send me ten days' examination Morecroft's "Elements of Radio Communication." I agree to remit the price of the book within ten days after its receipt or return it postpaid.

Name.....

Address.....

Position or Reference.....

Subscriber Yes NoRB 12-29

**CHANGING SALES
CONDITIONS**

(Continued from page 73)

plainly told that static will occasionally prove annoying on any set they might buy; that good long distance reception is the exception rather than the rule, and that no radio is immune from local interference. The company has found that customers appreciate frankness in these respects.

When a new man is hired, Mr. Moore instructs him clearly and concisely with regard to the firm's policies. There is none of this "turning a man loose" to do as he pleases and in his own fashion.

Whenever a new model appears—and at any other time there may be occasion for it—a sales meeting is held. The features of the sets are pointed out one by one and Mr. Moore shows how they should be sold. Representatives of manufacturers and wholesalers are also asked to talk before these meetings occasionally as one of the best means of keeping the Universal salesmen strictly up to the minute.

Highly important in the handling of salesmen, says Mr. Moore, is in giving them a real incentive to put forth their best efforts. He believes that the commission method of paying men offers the best solution—providing the dealer's responsibility in the men does not cease with the mere offer of payment in case they produce. Hence, Universal salesmen are paid 10 per cent. commission on sales against a drawing account of \$40 a week. They also receive carfare for their work.

There is another important factor about Mr. Moore's method of paying his men. Fifteen per cent. of every 10 per cent. commission is held back by the company for three months until a fund of \$100 has been created in the salesman's favor. This has proved an effective and adequate guarantee against forced sales on the instalment plan where the customer's reluctance to meet payments might not be discovered for several months.

The Universal Radio Company wants its men to feel a direct responsibility in every sale they make. It is not taken for granted that salesmen call back at the home of every customer after sets have been in operation a couple of weeks, reports being necessary in every instance. This practice pleases the customer, insures successful operation of sets and results in obtaining new prospects.

ROBERT S. KRUSE

Consultant and Technical Writer

103 Meadowbrook Road, West Hartford, Conn.

Telephone Hartford 45327

A Radio Parts Guide

THE NEW

YAXLEY

Catalog



Send for it today for complete listings of Radio Convenience Outlets, Connector Plugs, Rheostats, Fixed and Grid Resistances, Jacks, Jack Switches, Phone Plugs, etc.

YAXLEY MFG. CO.

Dept. B, 1528W Adams St., Chicago, Ill.



**AUDIO
TRANSFORMERS**
Worthy of the
HAMMARLUND
Name Plate

DESIGNED primarily for the new "HiQ-30" Custom-Built Receiver, Hammarlund Transformers are a revelation in amplifying power and tone fidelity over the entire audible frequency range. The large cross-section core of specially treated laminations permits high primary currents without saturation. Completely shielded. Pigtail terminal leads for sub-panel connection. Four types: First stage, Push-Pull Input, Push-Pull Output for magnetic speakers, Push-Pull Output for dynamic speakers. Hear them! Try them! They will greatly improve the output from any circuit.

Write Dept. RB-12 for Details

HAMMARLUND MFG. CO.

424-438 W. 33rd St., New York

For Better Radio
Hammarlund
PRECISION
PRODUCTS

For Sale

Western Electric Type 1-A
500 Watt Transmitter

Western Electric Type 1-B
Power Panel

Western Electric Type 8-A
Speech Amplifier

Western Electric Motor
Generator, System to supply
1-A Transmitter including
antenna equipment
and tower.

Fleetwood Hotel
Miami Beach, Florida

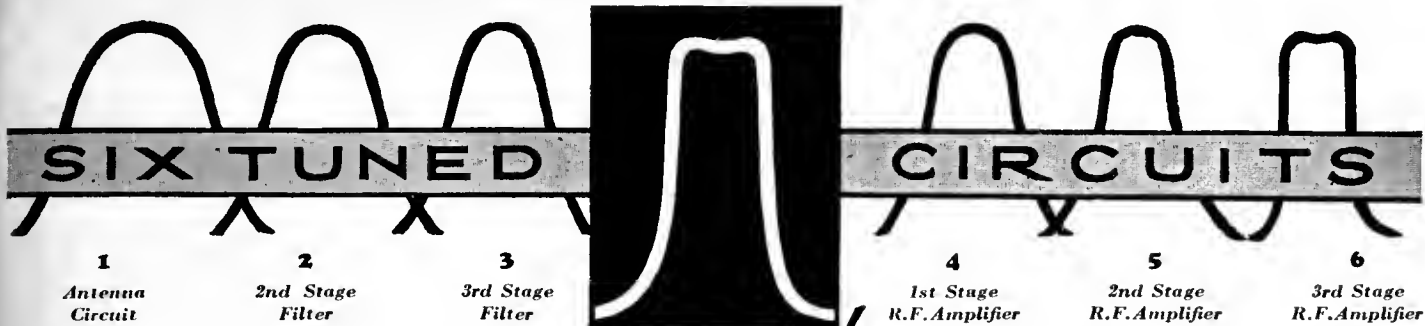

Tuned
BAND-FILTER

**FLAT-TOP - STRAIGHT-SIDE
 10-KILOCYCLE SELECTIVITY**

HAMMARLUND once again has put over a screen-grid, band-filter radio with six tuned circuits, so amazingly efficient that professional radio men by the score are building it for their own use.

The "HiQ-29" was a startling revelation, but in the words of Al. Jolson, "You ain't heard nothin' yet" like the "HiQ-30" performance—or the "HiQ-30" tone.

It is the only circuit that makes screen-grid tubes really do a day's work and the marvelous "HiQ-30" power amplifier with push-pull '45's takes all they can give it.

Pre-selected signals—ten-kilocycles apart—with no side-band cutting means *Selectivity* with a capital "S" and T-O-N-E that talks.

The easiest of all "HiQ's" to build too, with complete, factory-wired and tested units. No adjustments—no troubles. It percolates from the start.

A. C. or battery chassis fits standard cabinets, or your choice of nine special "HiQ-30" cabinets including phonograph combinations, \$139.50 to \$1175 complete, less tubes.

You should have a copy of the 48-page "HiQ-30" Manual. Price 25c. Use the coupon.

**WORLD'S
 PREMIER**



**CUSTOM
 RADIO**

Complete Factory-Built Units—Wired and Tested, ready to install.

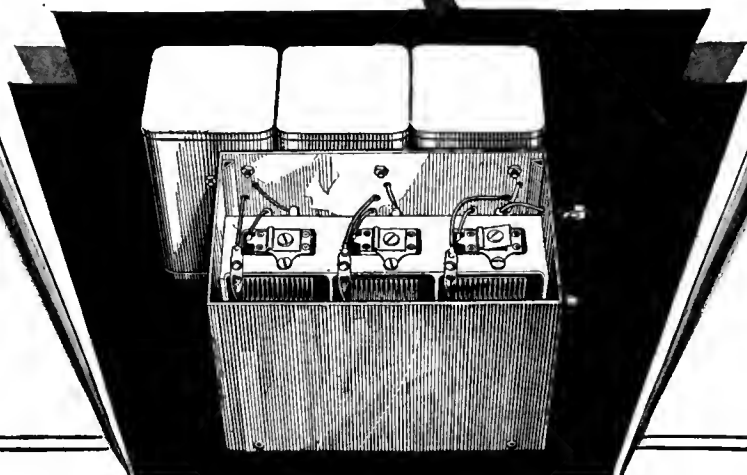

HAMMARLUND-ROBERTS, INC.
 Dept. RB 1,
 424-438 W. 33rd St., New York
 Enclosed 25c (stamps or coin)
 for HiQ-30 Manual.

Name.....
 Address.....

RADIO BROADCAST

PUBLISHED FOR THE RADIO INDUSTRY

WILLIS KINGSLEY WING Editor
 KEITH HENNEY Director of the Laboratory
 HOWARD E. RHODES Technical Editor
 EDGAR H. FELIX Contributing Editor



VOL. XVI. NO. 3

Contents for January, 1930

Don't Give Service Away	129
What Happened in Radio in 1929? In Merchandising	Edgar H. Felix 130
In Engineering	Keith Henney 131
A Service Department That Pays	Harry P. Bridge 132
Tested Sales Ideas	Merchandising Kinks 134
Bringing Them in Your Store	Unusual Advertising
Band Wagon Advertises Radio	Tying-in With Sports
Boosting Tube Sales	Cooperate With Your Theatre
Another Angle on Service	136
Professionally Speaking	Keith Henney 138
What About Independent Service Men? Regarding Advertising Claims	How the Industry Feels About Radio
A Few Interesting Radio Pictures of the Month	139
A Modern Radio for the Country Home	140
The March of Radio	An Editorial Interpretation 142
Beaching the Mass Market	7½-Kilocycle Channels Proposed
Cleared Channels Threatened Again	Station Distribution
New RCA-Victor Set Up	
A Radio Dealer's Tube Tester	James W. Blackwood 144
How We Look at Service Problems	Milton B. Hager 146
"Radio Broadcast's" Engineering Review Sheets	147
No. 27 Matching Impedances	No. 28. Electrons and Tube Testing
The Kinematic Remote Control	M. B. Sleeper 149
Clippings	What Radio Men Say 150
Strays From the Laboratory	Technical Shorts 151
A Novel Wavemeter	A "New" Recording System
An International Broadcaster	Two New Booklets
An Interesting Formula	
A Production Testing System	J. A. Callanan 152
Resonance and Reverberation	Howard E. Rhodes 154
The Tube Business	News of the Tube Industry 161
The Serviceman's Corner	164
A Symposium on Noise	A Useful Output Meter
"Radio Broadcast's" Set Data Sheets	168, 170, 172
Apex Model 36	The Majestic Model 90
Fada Models 10, 11, 30 and 31	The A.C. Dayton Navigator
A Reflex Vacuum Tube Voltmeter	173
News of the Radio Industry	174
General News	Financial Notes
Personal Notes	Production Notes
Distributors Appointed	Recent Patents
In the Radio Marketplace	Offerings of Manufacturers 180
Directory of Recent Price Changes	181
Radio Broadcast Laboratory Information Sheets	
No. 310. Factors Considered in Receiver Design	Howard E. Rhodes 182, 184, 186
No. 311. Effect of Reflections and Echos	No. 314. Selectivity in Radio Receivers
No. 312. Measurements of Sensitivity	No. 315. C-Bias Resistor Values
No. 313. Fidelity in Radio Receivers	No. 316. Range of Frequencies Required
	No. 317. Range of Frequencies Required
	No. 318. 60- and 120-cycle Hum Measurements

The contents of this magazine are indexed in *The Readers' Guide to Periodical Literature*, which is on file at all public libraries

. . . among other things

THIS MONTH, we give over this forum to a communication from the peripatetic Carl Dreher, who, having deserted the eastern seaboard, is now director of sound for RKO in Hollywood. Mr. Dreher, let it be said before we give him the floor, as author of "As the Broadcaster Sees It" was for many years a regular contributor to RADIO BROADCAST.

To The Editor:

Although I am now in the moving picture business, I still burn with solicitude for the poor broadcasters. For the Eastern members of the fraternity I have no fears; except for the irreparable loss which they sustained when I left their ranks, they seem to be getting on all right. But in the West I think the boys are headed for a bad time, aside from the stock market, gassy tubes, and their sweeties running around with fellows who don't have to work at night.

The California stations, I find, are laying on the advertising with a trowel. Not only that, but half of it is downright fraudulent. Maybe the listeners will continue to stand for it, but one day they may rise and throw receivers out of the windows by thousands. Then the poor ops will be out of their jobs.

Something had to be done and I have done it. By careful observation I discovered that the Coast announcers, while they recite the virtues of the local chiropractors, second-hand clothes shops, swamis, patent medicine dispensers, and other fakers, invariably use the word "folks" at least once in each sentence. I have accordingly invented a speech-operated, selective relay, known as the *folkstopper*. As soon as the announcer says "folks" it automatically opens the antenna circuit. After a ten-second interval, controlled by a dashpot, the circuit closes again, but if the announcer is still selling, "folks" shuts him off again.

The precise form to be taken by this latest wonder of science is unimportant. I don't bother with technical details. Mr. Grace, the lecturing vice president of the American Telephone and Telegraph Company, could design an efficient *folkstopper* in ten minutes. He has lots more intricate and less useful machines in his bag right now. Just give him the idea; and he'll elaborate on it.

You will probably object that as soon as the *folkstopper* gets into extensive use the announcers will stop saying "folks". That only shows you know nothing about California announcers. They can no more stop calling, listeners "folks" than they can stop breathing.

Sincerely yours,
 CARL DREHER.

TERMS: \$4.00 a year; single copies 35 cents; All rights reserved. Copyright, 1929, in the United States, Newfoundland, Great Britain, Canada, and other countries by

DOUBLEDAY, DORAN & COMPANY, INC., Garden City, New York

MAGAZINES
 COUNTRY LIFE . . . WORLD'S WORK . . THE AMERICAN HOME . . RADIO BROADCAST . . SHORT STORIES . . LE PETIT JOURNAL . . EL ECO . . WEST

BOOK SHOPS (Books of all Publishers)
 NEW YORK: <LOBB & TAYLOR, JAMES MCCREERY & COMPANY, PENNSYLVANIA TERMINAL, 166 WEST 32ND ST., 848 MADISON AVE., 51 EAST 44TH STREET, 420, 526, and 819 LEXINGTON AVENUE, GRAND CENTRAL TERMINAL, 10 WALL STREET> ATLANTIC CITY: <2807 BOARDWALK> CHICAGO: <75 EAST ADAMS STREET> ST. LOUIS: <310 N. 8TH ST. and 4914 MARYLAND AVE.> CLEVELAND: <HIGBEE COMPANY> SPRINGFIELD, MASS: <MEEKINS, PACKARD & WHEAT.

OFFICES

GARDEN CITY, N. Y. NEW YORK: 244 MADISON AVENUE. BOSTON: PARK SQUARE BUILDING. CHICAGO: PEOPLES GAS BUILDING. SANTA BARBARA, CAL. LONDON: WM. HEINEMANN, LTD. TORONTO: DOUBLEDAY, DORAN & GUNDEY, LTD.

OFFICERS

F. N. DOUBLEDAY, Chairman of the Board; NELSON DOUBLEDAY, President; GEORGE H. DORAN, Vice-President; RUSSELL DOUBLEDAY, Secretary; JOHN J. HESSIAN, Treasurer; LILLIAN A. COMSTOCK, Ass't Secretary; L. J. McNAUGHTON, Ass't Treasurer

DON'T GIVE SERVICE AWAY

HOW MUCH is good service worth? What will the customer pay? These are questions which are not yet solved by the radio trade. Service charges vary from \$1.00 an hour to \$2.50 or \$3.00, and so does the quality of the work. The quality may always vary, but collecting a fair price for service rendered will do much to improve service, stability, and profits of all radio dealers.

Out of the experience of the trade in service matters, acquired by inexorable experience, some degree of standardization of methods, charges, accounting, and general administration is developing. Service workers tinker less with sets in the customers' living rooms and solve problems presented by balky sets more and more in well-equipped service laboratories. Here and there, far-seeing dealers and servicemen are practising—to their eternal success—the undeniably successful plan of increasing their business by answering customer-demands promptly, and by keeping to the letter every promise they make. Where a service clientele is treated in this fashion one hears little complaint that "service work doesn't pay." Customers will pay for good service, but before they pay, good service must be given.

Few customers in search of service shop around here and there to get their maintenance or repair work done at bargain prices. Yet many dealers and independent servicemen are giving service—literally giving it—at bargain prices. In this situation, both customer and dealer suffer. Is there any guide to which dealers and servicemen can turn? We think there is in the Suggested Code of Business Practices for Radio Dealers, issued by the National Federation of Radio Associations.

The sections of this Code relating primarily to service work suggest that the dealer's free service be limited to sixty days, or after a limited number of calls specified at the time of sale. After the free-service period, not less than \$2.00 per hour should be charged for service required. A standard charge for antenna erection and installation is suggested. The recommendations in full follow:

Limiting Free Service. No free service to be rendered after 60 days, or after a

New Code of Business Practice, if Followed, Will Help Dealers in Making Service Calls Pay.

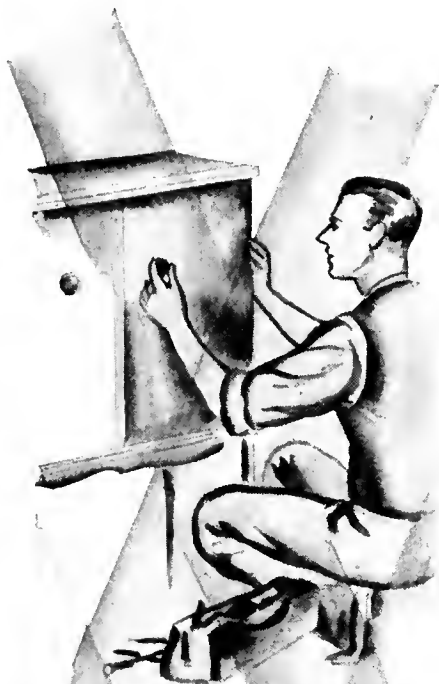

certain number of calls specified at the time of sale. In case of defective parts in the radio receivers after the 60-day free-service period, if the manufacturer's warranty covers free replacement and if the instrument has not been tampered with, the dealer should replace these parts, charging only for the labor involved.

Minimum Service Charge. If the free-service period has expired, a minimum service charge of \$2 should be made. If the call is of half-hour, or more duration, a specified rate per hour, plus cost of material should be charged.

Antenna Installations. If an outside antenna must be put up when a set is installed, a charge of \$7.50 should be made to meet the cost of labor and materials. If an inside antenna must be put up when the set is installed, a charge of \$5 should be made to meet the cost of labor and materials. If no antenna is necessary, but ground connections, lead-ins, etc., must be checked, at least \$2 should be charged to meet the cost of labor.

Advertising Policy. Truth in advertising must be observed to preserve the good reputation of the individual dealer and the entire trade. The code of ethics of the National Better Business Bureau on radio advertising should be followed.

Servicemen who are independent, or dealers with service departments may see some reason for service practices in their own cases different from those suggested. However, we believe that the practices and charges suggested by the Federation are the lowest, the very minimum with which the dealer or serviceman can be content if he desires to render real service and stay in the business at a profit.

Other items in the Suggested Code of the Federation follow:

Home Demonstrations. Prospective customers should be allowed a free trial or home demonstration for forty-eight hours.

Time Payments. An adequate interest charge should be made on all time-payment contracts and contracts should not extend beyond one year. These are standard practices in all other forms of time-payment selling.

Allowance for Trade-Ins. Considering the advertised list price as the cash price, the allowance on instruments offered for trade-in should be based only on their fair cash market value. This applies to the receiving set only, and does not cover tubes, batteries, and other accessories.

Many articles in past issues of this magazine have treated the question of good service at fair prices and a list of these articles will be sent to any reader requesting it.—THE EDITOR

WHAT HAPPENED

By EDGAR H. FELIX

MERCHANDISING



UNLIKE every other industry of equal magnitude, radio cannot report attaining any outstanding success during 1929, either through unusual and aggressive merchandising methods or the exploitation of a new engineering principle or invention, the reorganization of a major unit by consolidation or financial expansion, or the impelling influence of genius in executive management. Nor can the radio industry chronicle a new or difficult merchandising situation faced, met, or overcome, a colossal merger, or a great failure.

The large producers have maintained their relative positions but greatly increased their manufacturing facilities. Only one new name of consequence appears, Radio-Victor. It arrived there entirely by conventional methods, an advertising campaign of superlatives and the exploitation of a technical mystery word for dealers to conjure with. Without the accumulated good will behind the name Victor, it is doubtful whether the sales-promotion plan would have attracted any great attention.

New Developments? The industry cannot boast of any departures from the conventional console. In previous years, a leader has stood forth whose product was slavishly copied by the entire industry. This year, the industry is thrown into confusion because there is no outstanding success to copy. Where is the clarion call to sales around which a cheering public shall rally? Remote control? Automatic tuning? Condenser speakers? None of these have excited the public.

Screen-Grid Radio: If we analyze the dominant sales point for the year 1929—screen-grid radio—it is easy to determine why it failed to bring an enthusiastic response. Screen grid is merely accepted; it has not made obsolete previous production as did the appeals of other seasons, such as a.c. operation, electro-dynamic loud speakers, power output tubes, and single-control radio sets.

The outstanding capability of the screen-grid tube is its potentially greater amplification. The consumer expected tremendously greater sensitivity or else the previously accepted standard of sensitivity with less tubes and at much lower cost. But the gain in sensitivity has been almost imperceptible because noise level limitations make it a disadvantage rather than an advantage. Nor have substantially cheaper sets using less tubes appeared. Instead, the customer must pay just as much as before and use just as many tubes, more expensive tubes at that.

Price cuts: The failure of the industry to confer any substantial benefit through technical progress or reduced prices has resulted in a failure to absorb the greatly increased production capacity of the leaders in the industry. Faced with overproduction, the industry has wisely adopted a widespread series of price cuts, led by Atwater Kent, Majestic, R. C. A., Kellogg, and Colonial. Some financial writers attributed these price cuts to fear of reduced luxury purchases as a result of the stock market debacle but this conclusion is entirely erroneous. The price cuts were decided upon before the big break by failure of the industry to enlarge its service to the public.

A trend toward lower prices is bound to broaden the radio market. As radio reaches into lower and larger market levels, economy of maintenance becomes increasingly important. This may force the production of sets of greater efficiency to sell at \$50 and \$60, approximating the performance of sets now selling for \$125. Such sets may use but a single stage of screen-grid, radio-frequency amplification and a single output tube. Only with such sets available will the radio industry sell more units than the automotive industry.

Novelty appeal: In the attempt to find a new appeal with which to sweep the market, many expedients were tried. Most were obvious clap-trap which have as much appeal as an automatic wiper for the bathroom mirror. The public has not found turning a dial to a desired setting, the correctness of which is easily checked by ear, such a trying operation that a

mechanism of adjustable buttons, locking clamps, and flashing lights is anything to excite its enthusiasm. The public has recognized so-called automatic tuning of 1929 as the invention of despairing sales managers.

Remote-Control Tuning: This has possibilities, but the entire conception of radio installation must be modified before it means anything to the public. Dealers report that the public estimate of remote control is that it is a \$300 device enabling particularly

lazy persons to press buttons at the end of a six-foot cord rather than to reach for the tuning knob.

We are only at the beginning of this development. It will be a different story when remote control is intelligently merchandised. An enterprising manufacturer will have vision enough to market a complete radio installation: four to six remote-control points spread conveniently throughout the home—in living room, dining room, kitchen, and master bedroom—a compact metal chassis to be installed in cellar

(Concluded on page 162)

The Radio Year Just Closed Was Notable Not so Much for any Large Accomplishments Either in Engineering or in Sales as for Steady Progress in Many Small Ways. There Were Mistakes, Advances, and Shortcomings. But the Year Bubbled with Action. These Articles Weigh the Twelvemonth Interestingly. On this Page Edgar H. Felix Considers Conditions from the Merchandising Viewpoint and on the Facing Page Keith Henney Reviews the Engineering Progress of the Past Year.

IN RADIO IN 1929?

By KEITH HENNEY

ENGINEERING

ENGINEERING advance in 1929 centers around the development and introduction of new tubes. The most important of these is the a.c. screen-grid tube; others are the humless-heater and quick-heater types; finally the 245-type tube which has already been adopted by the industry.

The advantages of the screen-grid tube are two, greater inherent stability, and greater inherent amplification. Strangely enough neither of these advantages, nor the two together, is sufficient to produce an entirely new type of set or to make new receivers incomparably better than old. Before the introduction of the new tubes there were stable, high-gain, neutralized receivers.

Screen Grid Sets: The advantages of these sets lie in other directions than in greater sensitivity and stability. The by-products of the new tube are more important than the chief *raison d'être*. These by-products of the screen-grid tube were discovered; not thought out in advance.

The greater stage gain of the tube led some to believe a radio set could be made with less stages of amplification than was possible in 1928. Unfortunately just as many stages were required for selectivity's sake, and so the r.f. amplifier of 1929 has at least two screen-grid tubes, just as the 1928 set had at least two stages employing 227-type or equivalent tubes. This made a set which had much greater overall amplification than the set of previous years, but this amplification was not necessary; receivers already went down to the noise level in the average locality. And so some manufacturers reduced the a. f. amplification — and gained considerably thereby.

Low Hum: The receiver with one stage of a.f. needs less care in design to prevent undue hum. This is probably the greatest single advantage of the high gain r. f. amplifier—it makes possible a humless receiver which has good low-frequency response. Here it must be said that receivers with but a single a.f. stage (and hence a "power detector") were in use before the advent of screen-grid tubes, but not in general use in standard radio circuits.

Circuit Changes: This single a.f. stage and a high-gain r.f. amplifier made other changes in design which are advantageous. The volume control in some sets, for example, may now be made to operate on the a.f. end of the circuit so that when the volume is down, the hum is down too. Thus the ratio between signal and hum is constant and does not decrease when the volume is turned down as in the older sets where all the volume control was in the r.f. amplifier.

Screen-grid receivers may be somewhat more selective than

triode sets with the same number of stages. However, these receivers are still not selective enough, or rather, they are not selective in the proper manner. They are too sharp at 5 kc. off resonance, too broad at 10 kc. off resonance.

In some sets sensitivity has been sacrificed in favor of reducing the cost of shielding; in some sets the newer tubes have been used for benefit of the sales department, or for some mechanical reason.

Linear Detectors: High-output r. f. amplifiers have required detectors with a high overload limit. Such detectors have some portion at least of their characteristic which is linear, the advantage being less distortion on high modulation and somewhat greater selectivity. More research is necessary either to make truly linear detectors or to extend the range over which the detection is linear, or to develop new detectors which are more linear or more efficient.

Power: The 245 tube in push-pull makes possible a power output of about 3 watts which is sufficient for the average home. Some users require more power output and can get it from the few sets which use 250-type tubes in push pull. It is probable that power output will not change greatly in 1930. It may be secured somewhat more efficiently by the use of new tubes but it will not be lowered—unless vastly more sensitive loud speakers make their appearance—and power output need not be appreciably increased.

The new heater type of tube which does not crackle or hum is a distinct advantage; the quick heater is an advance provided life, or freedom from noise, or both, are not sacrificed. At present the 5-10-second tube seems a good compromise between all the essential and desired characteristics.

Volume Control: This year saw two developments in volume control, the local-distance switch which changed the sensitivity of

the receiver in a big jump, say 40 to 1 in voltage, and the variable type which reduces the coupling or gain to the antenna at the same time the sensitivity of the receiver is decreased. Either of these seems satisfactory but those which vary the coupling alone or the sensitivity alone are not generally satisfactory due to cross talk, overloading, etc.

Greater use of the automatic volume control circuits was evidenced during the year. A control of about 300 to 1 in voltage due to automatic control, and a 40-to-1 control due a

(Concluded on page 162)



Behind the scenes of

A SERVICE

By HARRY P. BRIDGE, JR.

Two points of particular interest stand out in connection with the generally interesting service department of the Universal Radio Corporation, Juniper and Arch Sts. Philadelphia, Penn. In the first place, this department has shown a profit from the start. Secondly, it has been largely divorced from the store proper as a means of putting it "on its own" to rise or fall according to its merit.

To an outsider, these facts might hold little or no significance. "Just good business," he might say and let it go at that. To one initiated into the mysteries of selling radio at retail, however, a glance behind the scenes might prove both interesting and enlightening. He has probably seen all too many service departments operating at a loss. And he has probably known many more stores where this work is regarded as a necessary evil—a mere sideline to the main issue which is the sale of new sets.

In the Universal Radio Corporation, the service department is *not* a sideline. Service Manager C. A. McCrork has been charged with the production of a worth-while profit on his regular service work and has come through with flying colors. To him, and to those who work with him, the service department is a bread-and-butter business. No sidelines, no sidestepping the issue which is so plainly told in red or black figures on the ledgers. In this organization it is the work of the sales department to produce sales. The work of the servicemen lies in keeping customers satisfied and, equally important, in proving their department's right to existence where only the fees collected from the service work can be taken into consideration in computing profit or loss.

Separated From Sales Department

Housed in the basement of the company's retail store, the service department's records are kept separate and distinct. The work of servicing sales free of charge for 90 days is regarded as part of the department's expense of doing business.

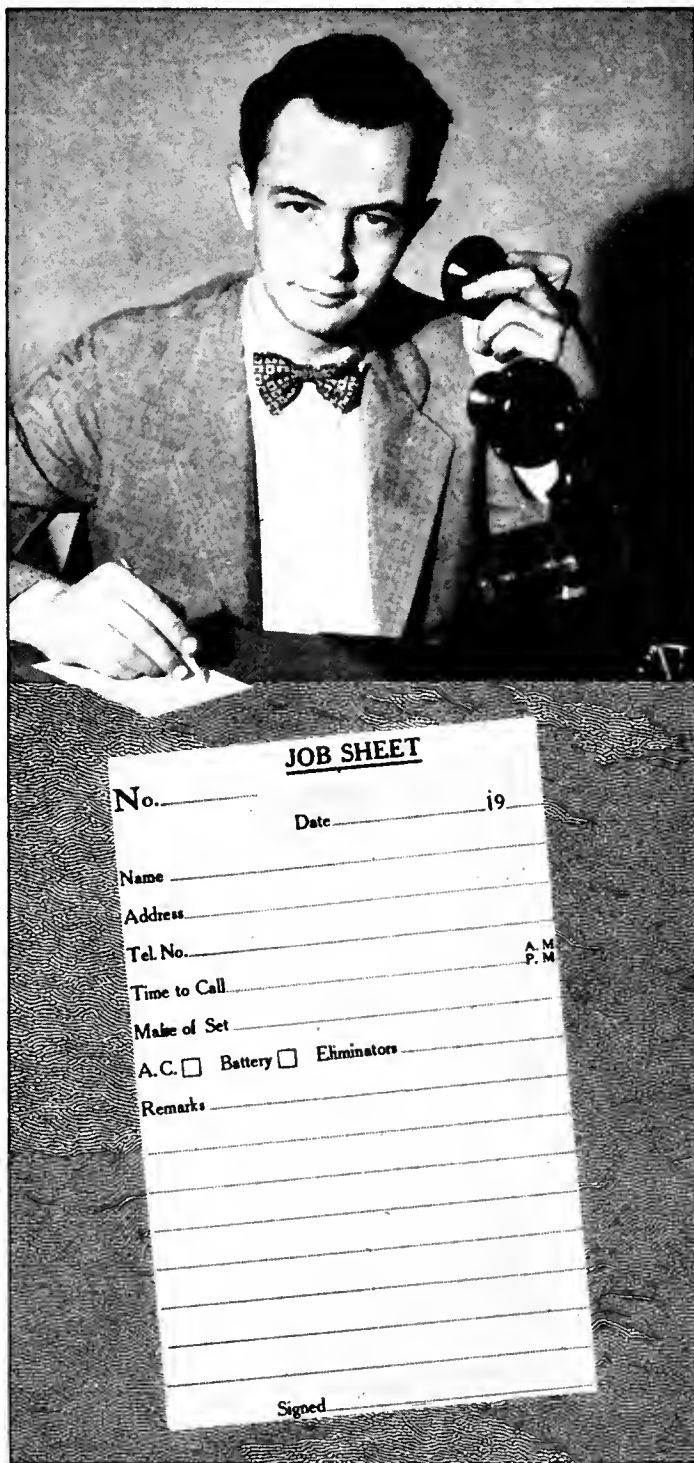

JOB SHEET

No. _____ Date _____ 19__

Name _____

Address _____

Tel. No. _____ A. M. P. M.

Time to Call _____

Make of Set _____

A.C. Battery Eliminators _____

Remarks _____

Signed _____

C. A. McCrork says—

Keep Service Records Separate and Distinct

Make 24-Hour Service Your Rule

Do All Work on a Cash Basis

Make Definite Appointments for all Outside Calls

Charge a Minimum of \$2.00 for Every Outside Call

Employ Men Who Will Provide Their Own Cars, Tools, and Test Sets

UNIVERSAL RADIO CORPORATION
1321 ARCH STREET PHILADELPHIA, PA. No. 1450

NAME		DATE
ADDRESS		PHONE
Set	Work to be done	PRICE
Items	CONDITION OF	REPAIRED OR REPLACED
Tubes		
Batts. "A"		
"B"		
"C"		
		ACCESSORIES
Elim. A		LABOR
"B"		TOTAL
Speaker		Terms
Ant.		Charge to
Ord.		

REMARKS: _____

We Shall Consider Work Satisfactory, Unless Notified to the Contrary Within Two (2) Days

DEPARTMENT THAT PAYS

Out-and-out service calls are relied on to produce a regular profit—and do.

“Service is the Supreme Commitment of Life” reads an inscription which hangs near Mr. McCrork’s desk. Everything possible is done to sink the significance of this motto into the minds of those connected with the department.

“When a radio goes bad, the person who calls wants service—not a promise,” says Mr. McCrork. “Consequently, when we say a man will be there to fix it at such and such a time, we mean exactly what we say. ‘Service’ is a much abused word, but we’re working hard to give it a real meaning as far as this business is concerned.”

Universal service rates are \$2 an hour with this figure also representing the minimum. Charges are figured from the time the man starts for the job until he is ready to go on to the next one. There are no charge accounts in this service department, collections being made by the men when sets are repaired in the home. If it is necessary to bring an outfit to the shop, it is repaired with equal promptness and delivered C. O. D.

Not only has this system done away with a great deal of bookkeeping, but it has also eliminated annoying losses from bad accounts. The serviceman gives the customer a receipt and turns the money with his report on the job over to the cashier at the store. Then, to provide a check on the transaction, a card thanking the customer and expressing the company’s wish that the work prove satisfactory is mailed from the office. The amount paid is mentioned on each card.

Twenty-four-hour service is an invariable rule with Universal. Servicemen are required to have their own automobiles, the operating expenses of which are paid by the company. Philadelphia covers a vast expanse and quick trans-

portation is essential to the economical conduct of the work. The increased cost of having men use automobiles has been more than made up by the greater number of calls they are able to make.

How Jobs are Handled

When a service call comes in, it is registered on a job sheet which immediately goes to Mr. McCrork. In addition to the customary name and address, the girl at the phone desk gets the customer to set a time when it will be convenient to have the serviceman call. She also gets the customer’s full name, address, and telephone number, and the make and type of set to be repaired.

As far as possible, service work is routed. Calls are grouped according to the various sections of the city. In selecting his men, Mr. McCrork endeavors to get men who live in different districts. Thus, in many cases, it is not necessary for the men to come into the store in the morning and in doing so go many miles out of their way. A man may be given his route sheet the night before and instructed to go directly to the first job in the morning. Then, to round out this system, each man is required to report via telephone at least four times during the day. He tells the operator where he is and is given any additional calls from that territory which may have come in since he has left. Under this method surprisingly prompt service can readily be made the rule rather than the exception.

If a serviceman gets behind on his schedule—and this is sometimes unavoidable—he is required to call those whose sets are still to be repaired and inform them of the fact. He tells them just when he will be there and if they will not be at home at the time, he makes another definite appointment at their convenience. If the delay promises to prove inconvenient to the customer, the original date is kept by the simple expedient of sending a man out from the store in

(Concluded on page 183)

A view of the test bench in the service department of the Universal Radio Corporation, Philadelphia, Penn.



TESTED SALES IDEAS

Bring Them in Your Store

DO THE dulcet strains of your finest radio set fail to halt the crowds passing your windows on the way to your competitor's? Is your display equal to, if not superior to his, and are your prices cheaper? Is the trade his because of earlier establishment in the neighborhood?

Well, if any of these conditions apply, there is another way to cause people to stop at your window. You can even do more than that—you can make them enter your doorway, and perhaps buy. This is how to do it: *install a free scale in your doorway.*

Now let's see how the plan works. Everyone likes to get weighed. Scales are scattered along the streets of every city, in waiting rooms, in theatre lobbies, etc., and you'll always find somebody patronizing them. Few can resist a scale.

Why not capitalize on this desire? A store in Philadelphia adopted this method of advertising with the result that approximately 100 persons per hour enter their doorway to be weighed. And before they get on the scales, while they are on it, or before they get off they gaze around and discover the windows, which is the desired result.

LEO I. MOONEY, Philadelphia, Penn.

Band Wagon Advertises Radio

We have prepared for display purposes a rather unusual truck which we have christened "The Fada Band Wagon." This truck has been especially built to carry around our territory a complete display of radio apparatus and accessories of interest to the radio dealer. It is so constructed that the back unfolds, thereby providing a stairway which makes easy access to the display. The right side of the truck also unfolds, thus presenting to view a full-size room in which a complete line of receivers is on display.

With this equipment we are able to demonstrate the merits of each receiver for the dealer as the truck is completely wired and each receiver is connected. Power for the receivers is obtained with the aid of a long extension cord. We plan to use the truck exclusively for demonstrating Fada receivers to dealers in our territory.

C. C. BAINES, manager, Radio Department,
Peaslee-Gaulbert Company, Louisville, Ky.

Boosting Tube Sales

Mr. Boyd, manager of the Baldwin Piano Company, Indianapolis, Ind., is a man who knows human nature. He knows that the best way to remind and impress people is to show them; and that they will feel the urge to buy if buying



Each Month These Pages Serve as Our Clearing House for Merchandising Ideas of Proved Value. Every Radio Dealer Should Read Them Carefully

is made easy. If they see a product prominently and attractively displayed, they are reminded of a possible need. Otherwise they wait until the force of necessity makes them buy, and then possibly they buy elsewhere.

By placing these theories in practice and concentrating on tubes Mr. Boyd has been successful in selling \$1000 worth of radio tubes a month. This is how he did it. Mr. Boyd realized that radio tubes are constantly in demand and he decided to install a special tube counter near the front entrance of his store so that people coming in for other merchandise might see it. It was fully equipped with testing apparatus, display material, and a substantial stock. Tubes could be tested and bought quickly and in this manner a source of profits that had previously been untapped began to roll in. In addition, a campaign was mailed to radio owners throughout the city and this brought additional prospects to the store.

Unusual Advertising

In Del Ray, Calif., a small town having a population of only 110, there is a very unusual radio dealer. This dealer, Ira Fautz, sells Atwater Kent receivers exclusively and uses very novel advertising and merchandising

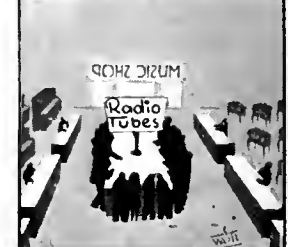



\$5.00 FOR YOUR PET SALES IDEA

These pages are a regular feature of *Radio Broadcast* where we present ideas, both big and little, which are of proved service to dealers. If you have a pet sales idea, a stunt that produced results for you, tell us about it. *Radio Broadcast* will pay \$5 for each contribution used. A letter will describe the idea, a rough pencil sketch or photograph will help illustrate it and we shall do the rest. If you have a pet sales idea, send it in. Address Merchandising Editor, *Radio Broadcast*, Garden City, New York.

set is put in view in the lobby of the theatre for about a week before it is given away. Over the set is placed a placard giving the name of the dealer etc.

With every ticket sold at the theatre the patron receives a card. The stub of this card is filled out with the patron's name and address and a brief description of his radio and is dropped into the box. These stubs, after the lucky one has been picked out the night the set is given away, are saved. On the half of the card retained by the patron it states that a discount of \$10.00 or so will be allowed on any set purchased within a given time. There are many people who do not own sets who will take advantage of this offer.

The stubs containing the names and addresses of the theatre goers are saved by the theatre for the dealer. In most cases there will be several thousand of these and they will be found to contain the names of hundreds of prospective customers. If the persons who do not own sets or who possess battery-operated models can not be personally interviewed by the dealer a personal letter should be sent describing his line of sets and the discount.

By sacrificing one set the dealer will be able to close a great many sales and will gain in the end.

EDWARD V. PIRANIAN,
Philadelphia, Penn.

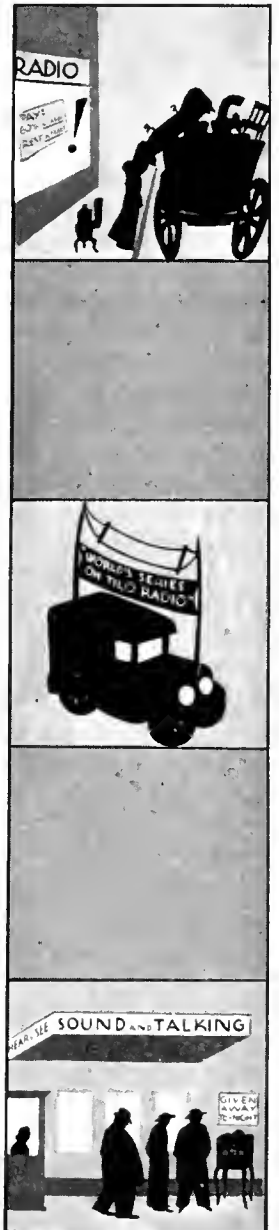

methods to promote his business. The standing offer which he has made to the people of his town is that he will accept anything from raisins up to a ranch in exchange for a new radio receiver, providing the exchange does not exceed 40 per cent. of the cost of the set.

Fautz writes his own advertising copy and much of it is quite individualistic and unusual to say the least. He makes free use of similes and out-of-the-ordinary selling arguments. Here is a sample paragraph or so from one of his bulletins:

"We are continuing our special proposition—60 per cent. cash and balance in trade, if suitable.

"Wanted: Household furniture, roofing, bookcase, fencing, rugs, sewing machine, fan, poultry, livestock, etc. What have you?"

"See us for tubes, batteries, supplies, service calls, and repairs at reasonable rates. Ask for a demonstration on the Atwater Kent Screen-Grid Sets. Buy now and get all winter programs.

"Trade your raisins for a Radio!"

Tying-in With Sports

F. A. Tomlin, owner of the Tomlin Battery and Radio Shop, Havana, Ill., estimates that he attracted thousands of dollars worth of prospective sales by a publicity stunt which cost him exactly 34 cents. In this particular case the stunt was a tie-in with the World's Series, but the same plan could be followed during any important broadcast.

Mr. Tomlin equipped the store's delivery truck with a popular-priced screen-grid receiver and parked in the business district of his city every afternoon during the World's Series. Using two fishing poles as a support for the aerial and an electrodynamic loud speaker in a large baffleboard at the rear of the truck, radio programs could be heard at a distance of two blocks away. As a result thousands of people stopped to listen to the exciting games.

The cost of the whole publicity stunt was only the expense involved in buying cloth to make a display sign advertising the receiver used in the demonstration.

Coöperate With Your Theatre

The following idea which has repeatedly been carried out successfully and which will yield any alert dealer plenty of sales. It is not merely an experiment but has paid several dealers satisfactorily. All you need to do is to go to your local theatre manager and offer one of your receiving sets as a lucky prize. The manager will be only too glad to do this as it will increase his own business as well as yours. The

*Let's Look at How Others
Handle Their Repairs*

ANOTHER ANGLE ON SERVICE

*Ten Years Ago the Automotive Industry
Faced a Service Problem Similar to Ours.
The Way in Which These Difficulties Were
Overcome Should Therefore be of Great
Interest to the Entire Radio Industry.*

NO ONE in any way connected with the selling of radio receiving sets will question the statement that the servicing problem is the bugbear of the radio trade. A radio set, once sold, cannot be dismissed from the minds of manufacturer, distributor, and dealer; the purchaser keeps coming back, like Hamlet's ghost, to plague the dealer with awful mumblings of dissatisfaction. And, like Hamlet, the radio dealer, the distributor, and the manufacturer know no peace of mind until by proper servicing they have stilled the customer's hollow protests.

This matter of servicing the sold set has been studied and re-studied by the entire radio industry. Somewhere there is a median line on which a service policy can be drawn without eating up too much of the dealers', distributors', and manufacturers' profits on the one side, and without nibbling too annoyingly into the customers' pocketbooks on the other. Where that median line should begin and end has yet to be determined to the satisfaction of the radio industry.

The automobile industry has had much longer experience with just as bothersome a service problem, and has learned much that may be of value to the radio industry. At first glance, to be sure, there seems little resemblance between the servicing that an automobile requires and the servicing that a radio set needs. A faulty cylinder block is rather different from a bent condenser, no matter how you look at them. But in the fundamentals of merchandising, the automobile industry and the radio industry face precisely the same problem. There are some things which the automobile trade has done that should be of interest to the radio trade.

The First Step in Servicing

The first, and most natural, step in servicing automobiles came in the form of "repair garages," independently operated by more or less skilled mechanics. At the start, these garages did more or less satisfactory work on any and all makes of cars, and charged whatever they saw fit for doing so. They were in part responsible for the old catch-line, "It's not the cost, it's the upkeep," that so generally described the pleasures of automobile ownership prior to 1920.

It didn't take the automobile dealers long to realize that

they were the big losers under this repair-garage system. First, when the customer went to the repair-garage, the dealer lost contact with him, and when the customer was ready to buy a second car, he was quite as likely to go to another dealer as to return to the first one. Secondly, the repair-garage did not give the customer complete satisfaction, since, in handling all makes of cars, the mechanics could specialize in none. And thirdly, the dealer was losing a possible profit in repair work.

Specialists Enter the Field

So the next logical step was for the dealer to establish a service department of his own. There the customer was assured that trained specialists would diagnose and repair any trouble his car might develop, and there the dealer could chat with the customer whenever he drove in for repairs. The psychological advantages of that, when it came to selling the customer a new car, were obvious. And the customer was satisfied, for it is a proved fact that the customer prefers to do his repair transactions with the dealer who sold him the car; he naturally feels that the dealer is more interested in keeping his car running well than is the proprietor of an independent repair garage.

The manufacturers and distributors were quick to see that the dealer's service problem was also their problem. During the past ten years they have made great strides in the right direction; to-day every manufacturer has his own factory service shop, to which the dealer can send big repair jobs, and the large distributors have established remarkably efficient and well-equipped service shops to which dealers in their territory can turn.

The dealer service shop solves the problem for the dealer and the motorist in the large cities. There the dealer, and certainly the distributor, does a sufficient volume of business to warrant making a sizable investment in service-shop equipment, and the volume of repair business that comes to him from his customers is such that his shop pays for itself and a bit more. Also, in the large cities, trained mechanics are readily available.

But the dealer in the small city and the country town can't afford to establish his own repair-shop. The volume of

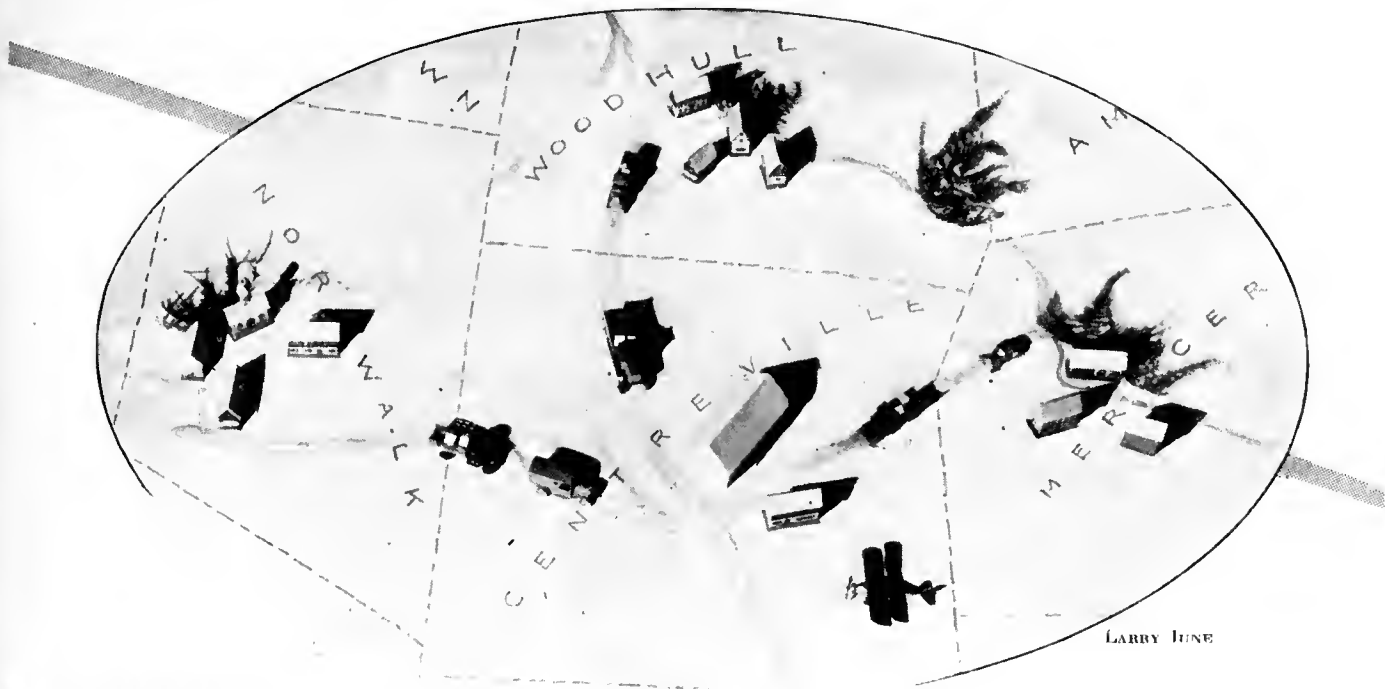

Will a central repair factory solve our rural service problem?

his repair business is so small that he can't justify the investment necessary to equip the shop with welding machines, machine-tools, etc; in many cases he can't even afford to keep a full line of spare or replacement parts. Now, 64 per cent. of the automobiles sold in the United States in 1928 were sold by small dealers—those in cities of less than 500,000 people, and more than half of that 64 per cent. were sold by dealers in towns of less than 25,000. There the service problem is still unsolved; the independent garages are getting the repair work, and the dealers are losing potential sales and profits.

The automobile industry divides service into two classes: *attentive maintenance*, which keeps cars in good running condition until repairs are necessary; and *corrective maintenance*, which repairs the ailments caused by accidents or wear. And, since the small dealer cannot handle the corrective-maintenance service, he has started to compensate by giving attentive-maintenance service.

For years the automobile dealers have given every car they sell a free overhaul at the end of its breaking-in mileage. These overhauls are attentive maintenance, and are now considered an integral part of the sales transaction. They are comparable to the "free call-back" which a few far-sighted radio dealers have instructed their servicemen to make within a week after a new set has been installed in a customer's home.

Super Attentive Service

The small dealer, and the "super-service" filling stations which are now playing-up attentive maintenance with the backing of the oil companies and accessories manufacturers, have developed that attentive service to the point where the car-owner is relieved of all responsibility and mental strain. For a small annual fee, say \$15, \$20, or \$25, the dealer agrees to change oil, grease the transmission and rear-end regularly, keep the springs and body free from squeaks and rattles, see that the headlights are properly focussed, the wiring and battery in good condition—in short, to do all the little jobs that will keep the car running well. Furthermore, he agrees to notify the car-owner whenever any of those jobs should be done, so the owner doesn't even have to think of dates or mileage totals. The result is that the owner has a car which

runs better than it ever did while he was attempting to remember about those details, and he is only paying a nominal fee for it. In addition the dealer not only retains a close contact with the customer, but he sells him more gas, oil, and grease than he possibly could otherwise.

The possibilities that exist for the radio dealer who adapts this attentive-maintenance plan to his business are obvious.

In the field of corrective maintenance, or actual repair work, the small automobile dealer's position has already been stated. At present, the independent garages are getting his repair business and his profits, and he is losing out with his customers.

The automobile industry, however, has recently evolved what promises to be a complete solution of the small dealer's service problem. The idea has already been tried out on a small scale, and has been found to be completely satisfactory from the viewpoints of the customer and dealer alike. It also has many points which recommend it to the manufacturer and the distributor, and it is probable that within a few years it will be in general use throughout the country.

Regional Repair Factories

The plan is based upon a chain of "regional repair factories," each of which will handle all the repair business within a given territory. It is economically sound, and in actual practice it seems to be even more suited to the radio industry than it is to the automobile industry, since it is easier and less expensive to transport radio sets over great distances than damaged automobiles.

The regional repair factory, in brief, merely puts a number of specialists under one roof, and insures them sufficient business to make the factory profitable. It is estimated that, in the automobile industry, about one repair factory to a county will be sufficient. This one factory, handling all the repair business within a radius of ten to twenty miles, will operate on a purely wholesale basis, doing no work for customers direct.

The car-owner takes his car to the dealer from whom he bought it. If it is a major repair job, beyond the capabilities of the dealer's serviceman, the dealer sends the car to the regional repair factory. There, with the most complete repair

(Concluded on page 185)

PROFESSIONALLY



SPEAKING

WHAT ABOUT INDEPENDENT SERVICEMEN?

Servicemen who have no direct connection with sales organizations feel themselves handicapped and not squarely treated when their requests for service data from certain manufacturers are turned down. They feel that if they are to service receivers, even though they are not the manufacturer's authorized dealer, they ought to have all the available information. And we believe they are right.

It is certain that a manufacturer does not want every man who can wield a screw driver to have a detailed description of his receiver; but it is the serviceman's contention—and again we believe he is right—that it is no proof that a serviceman is a seven-days' wonder just because he is attached to some organization whose primary purpose in existing is to sell receivers and not to service them.

We believe it would be a much better plan to give as much helpful service data as possible to everyone who qualifies for this information. But we do not believe qualification should depend upon a willingness to invest some dollars in a few sets at wholesale prices. In other words, the qualifications for getting service data should be the ability to service a set and not to sell it. It is a serviceman's job to fix sets and to keep them sold; not to sell them in the first place.

Why would it not be a good plan to prepare an examination which a prospective recipient of service data could fill out, thereby either satisfying the manufacturer or damning himself in his eyes? It may be felt that permitting an independent service organization to fix a receiver works an unnecessary hardship upon the service department of the authorized dealer in the locality, but it is our idea that if this service department does its job better than the independent there will be no need to worry, especially if both servicemen have had to pass the same technical examination.

REGARDING ADVERTISING CLAIMS

Parks and Hull, Baltimore distributors for Atwater Kent, put an Atwater Kent Model 55 screen-grid receiver on life test. They tuned it to a local station at full volume, the voice coil of the loud speaker was removed from the field, and the set was left to its silent task. Day and night the set was connected to the a.c. mains, part of the time a.f. signals were coursing their way through the loud speaker and associated circuits.

At the end of 816 hours the set was turned off and the tubes were retested. It was found that the tubes were but little different from what the test indicated at the start of the experiment. Some had increased slightly in emission, others had decreased slightly. This test of 816 hours is equal to about 275 days of service, in the average listener's home.

Attention—

A plan for distributing service information to all qualified servicemen.

Our problem—to inform factory managers of the cure for man-made static.

Good and bad advertising claims, and which is which.

Let's have more life and performance tests.

Out in South Dakota something went wrong in a power house supplying an Indian school. In this school there was an Atwater Kent Model 60 receiver. Instead of delivering 110 volts to the set the power wires supplied 220 volts. Electric lights in the building began to pop and burn out. When the electrician arrived, a half hour after the ruckus began, he found the set playing with considerable volume, tube shields very warm, and everything going along at a merry clip.

After the power wires had been fixed up, the A.K. came back to normal without any bad effects and at this writing the receiver is operating as well as when it was new.

On August 3rd L. T. Breck, vice president in charge of merchandising, Kolster Radio Corporation, picked a Kolster, which is a medium-priced set, and a Brandes, which is a low-priced set, out of the production lines and put them on life test. Day and night they operated at full voltage and volume. At the end of 2000 hours they were still going strong. No tubes had been changed; no service had been required.

We believe that life tests which give actual hours of test, some reference to the conditions of the test, or any definite quantitative data make much better advertising or news copy than the vague generalities which are in common use.

Compare these three stories with the following statement which is quoted from a recent advertisement for a radio product, "Comparative tests show that our product stands up longer in life test than any similar product on the market."

HOW INDUSTRY FEELS ABOUT RADIO

There are many hundreds of listeners to radio programs in Hartford, Connecticut, just as there are in other manufacturing cities. Not a few of these listeners have been bothered by nightly man-made static emanating from an airplane factory. One of them had the temerity to write the factory manager protesting about the racket that spoiled reception. We did not see this letter but the factory manager's reply seems to be characteristic of many industrial plants:

"There is little or nothing we can do to help out this condition, and suggest that you refer the matter to the manufacturer of your radio set, as it can not be expected that the manufacturing industry is going to spend millions of dollars to radio shield their properties."

This letter indicates no desire to alleviate an annoying situation; it shows that no attempt had been made to find out what made the noise and how it could be eliminated. It proves that the factory manager did not know that a few dollars invested in an interference eliminator would inhibit all but the most virulent type of racket.

The name of this plant manager will be furnished any interference eliminator manufacturer who wants to take his life in his hands for the benefit of the radio industry.

A FEW INTERESTING RADIO PICTURES OF THE MONTH

The "Temple of the Air" cabin monoplane on the right has made a cross-country sales-promotion tour. Those with the plane are (left to right): Lieut. Frank Hoffman, pilot; Cliff Bellingier, sales-promotion director; Gabriel J. Tolun, publicity director; and Chas. Mautzer, Temple dealer.

Upper right in circle: During the trial trip of the recently completed U. S. Cruiser Salt Lake City radio and phonograph music was available to officers and men through the medium of a Victor Radio with Electrola installed in the ship's wardroom.

In the toll house (below) on the James River Bridge, Va., an Atwater-Kent receiver has been installed for the entertainment of the toll keepers. It operates perfectly with four large high-tension transformers all around it.

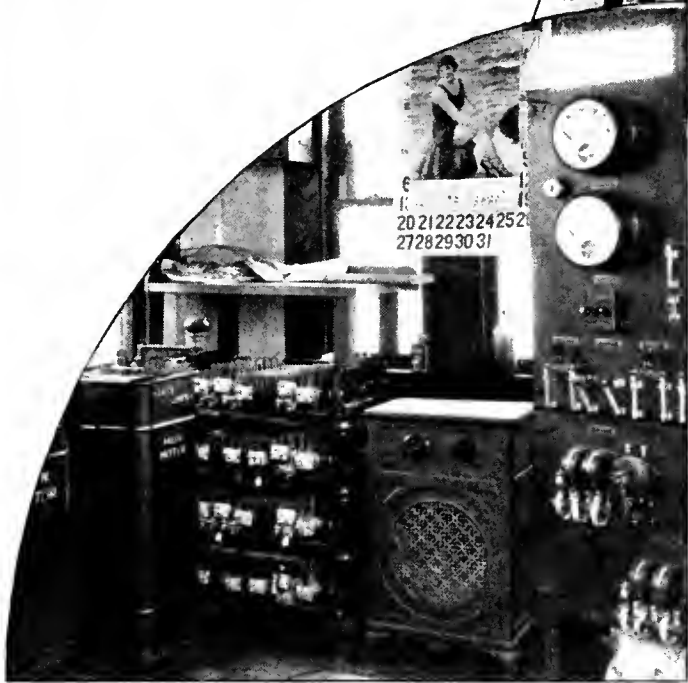
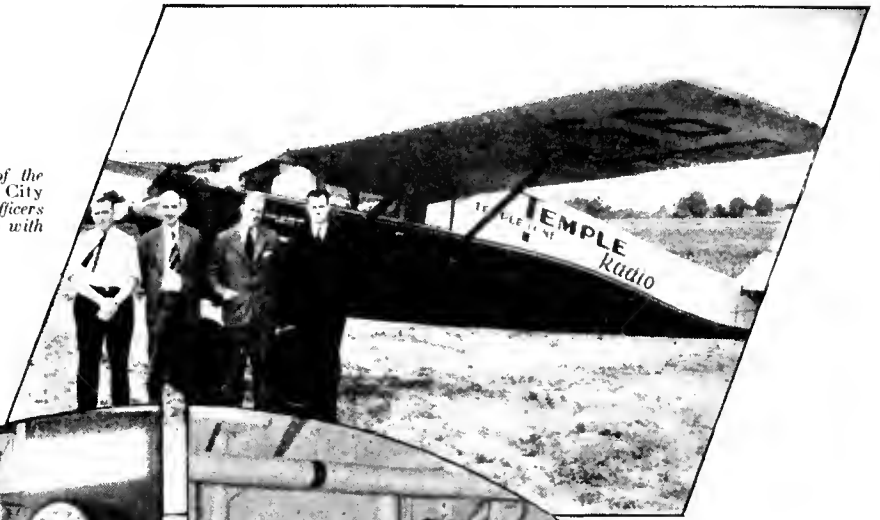

This youthful veteran (above) has tested 160,000 receiving sets since she started working for the Crosley Radio Corporation, in Cincinnati, O., eight years ago.

The view on the left shows one of the large vacuum tube assembly rooms in one of the factories of the Sylvania Products Company, Eaportium, Penn.

Lower left in circle: After their perilous flight from Moscow to Oakland Cal., the Soviet Flyers heard felicitations for themselves pouring from a Grebe receiver especially installed for them by Ralph Weinstock, radio distributor in San Francisco.

A MODERN RADIO for the COUNTRY HOME

MANY OF THE loveliest homes in America are located far from cities, far from the sources of electrical power upon which larger communities depend." So reads the booklet describing the first Screen-Grid RCA Radiolas designed primarily for homes without electricity. RCA dealers, however, have an eye on the vast market among people who have electricity and who now possess a set of ancient vintage operating from batteries or from a socket-power unit which seems too good to throw away in favor of an electric set. These people will find that they can improve the results obtained from their radio by buying the new farm set and operating it with their old accessories.

The Radiola 21 is a battery-operated screen-grid set of good sensitivity and selectivity, and it possesses an up-to-date a.f. amplifier system so that excellent fidelity of response is possible. It must be used with an external loud speaker. When placed in a Queen Anne cabinet of the type illustrated and permanently connected to a Radiola 100B loud speaker mechanism, which is mounted in the large baffle formed by the front of the console cabinet, the receiver becomes Radiola 22.

The advantages of the receivers are briefly, modern equipment, low upkeep cost, and low first cost. A receiver for the home without power wires must operate satisfactorily on battery current of a comparatively low value. These receivers require about one ampere from the A battery, and, with a 171A-type power tube and 135 volts of B battery the total plate current drain, with volume control at maximum, is 35 milliamperes. The minimum drain is 25 milliamperes. With a 112A-type tube, and 180 volts of B battery, however, the current drain decreases to a maximum of slightly less than 30 milliamperes and the minimum of slightly less than 20 milliamperes. When using 112A power tube the volume is not appreciably less than with a 171A tube.

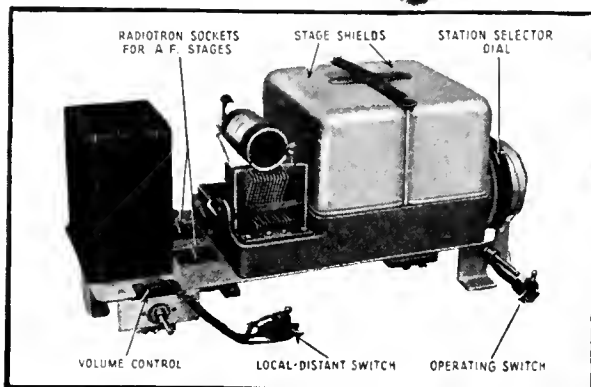
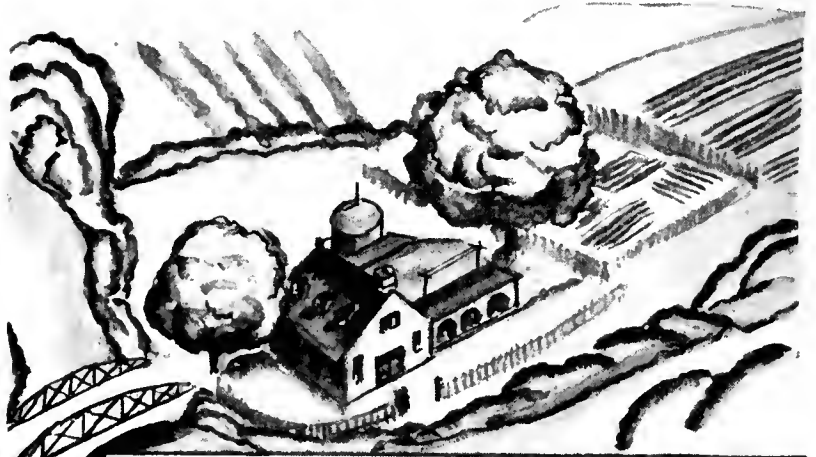

Describing One of the First Offerings of the Industry to Supply Users in Unwired Homes with a Set Comparing Favorably with Latest a.c. Models



A mechanical description will be found in the table, and the technical features are summarized below. The pictures give a good idea of the tuning mechanism and the arrangement of parts.

Features of Set

(a) Screen-grid battery receiver giving sensitivity and selectivity comparable to that obtained with a.c.-type screen-grid receivers.

(b) Circuit consists of two tuned r.f. stages, a tuned grid-leak-type detector, and the first and second a.f. stages with a choice of power tubes in the output stage.

(c) A local-distant switch provides best reception on both loud and weak signals. With the switch in the local position an 0.00023-mfd. condenser is connected from the antenna connection to ground. This condenser, or the antenna to ground capacity when the switch is at "distant," causes the circuit to resonate in the broadcast band at about 700 kc., thereby increasing the sensitivity of the low-frequency end. The result is that the receiver has about equal sensitivity throughout the tuning range.

(d) The use of screen-grid tubes together with proper shielding, eliminates the necessity of neutralizing or other method of stabilizing.

(e) The volume control varies the voltage on the screen grids of the two r.f. tubes. This provides a smooth means of control which, together with the local-distant switch, provides a positive cut-off even on loud local stations.

(f) In addition to disconnecting the filament battery the operating switch disconnects the B voltage from the volume control. This prevents unnecessary B battery consumption when the set is not in use.

(g) A fixed regenerative detector gives added sensitivity to that circuit with a resulting gain in overall sensitivity. This does not require any adjustment during operation.

Electrical and Physical Specification

Type of Receiver—Screen-grid, tuned r.f., battery operated.
Recommended Antenna Length—25-60 feet.

Type of Filament Power—Storage battery or A power unit.

Type of Plate and Grid Power—B and C batteries or B power unit

Number and Types of Tubes—Two UX-222, two UX-112A, and one UX-112A, or UX-171A—Total 5.

Number of R.F. Stages—Two.

Type of Detector—Grid condenser and leak.

Number of A.F. Stages—Two

Type of Loud Speaker (R22 only)—Magnetic.

	R21	R22
Height	10.5 inches	40.5 inches
Depth	10.0 "	22.0 "
Width	20.5 "	21.5 "
Weight, alone	27 lbs.	44 lbs.
Weight, packed	40 lbs.	105 lbs.
Price (less tubes)	\$69.50	\$135.00

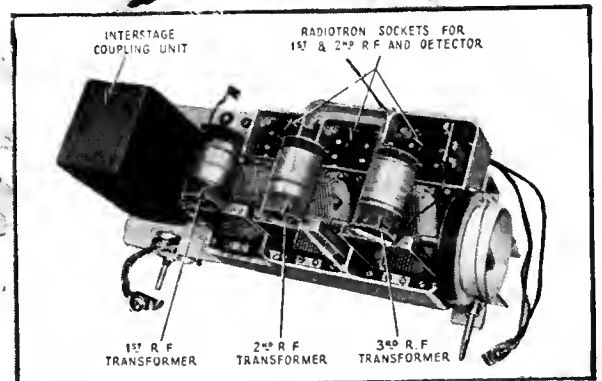

Galdon

The MARCH

Let's Market a \$35 Radio Receiver
Have Radio Broadcasters Made a Profit?

Reaching the Mass Market

THE RADIO INDUSTRY is fighting for its share of the consumer's surplus dollar with a \$150 article. That is the real price of the cheaper modern radio receivers, fully equipped with tubes and reproducer, installed and ready to use. Some well-known brands are listed at a lower price, but when the extras are summed up, including furniture, reproducer, and tubes, the totals are almost invariably nearer the \$150 than the \$100 mark.

While \$150 does not seem to be an excessively large unit, the great mass of American families are still waiting for a less costly introduction to radio. We hardly seem to realize that 68.6 per cent. of American families earn less than \$2000 a year and that 33 $\frac{1}{3}$ per cent. earn less than \$1500 a year. The resistance to purchasing a \$150 article in competition with the numerous other demands for every dollar earned, accounts for the relatively slow growth of the radio family. Most of the increase in sales totals of the last two years has been replacement business.

Radio has never been as democratic as it was in its earliest days when practically all the parts for a radio receiver could be purchased in a ten-cent store. During this early period in radio's development, we were called to address the assembly of a continuation school, an audience of young working boys who were compelled by law to spend a part of their time in school, practically all of them members of families having a net income of less than \$1000 a year. Over half of these were faithful earphone listeners, having built their own receivers. The march of progress has left them behind; the industry has found no place for them. Every other industry, which reaches into every strata of society, has found it profitable to appeal to this, the largest market, by marketing goods within their reach. To do so requires an entirely different approach, different advertising, and a different type of outlet than the industry now addresses with its \$150 goods.

It has been abundantly demonstrated, by the automobile industry in particular, that progressive buying is characteristic of the mass market. A very large percentage of Packard owners made their initiation into the automotive fraternity by purchasing a Ford. The lower the price strata to which an industry reaches, the more rapidly progressive buying finds larger markets for better quality goods.

It requires more than suitable sets at low first cost and upkeep expense to make inroads into the mass market. Broadcast program services must also be made available which appeal to that market. We are inclined to delude ourselves that we have broadcasting services to appeal to all classes of persons because programs are satisfactory to the existing audience. We have never ascertained the program desires of the great unsold market. Perhaps we might profit from the example of certain newspaper and magazine publishers who have found new fortunes by reaching further and further into the

mass market. Every convert from this group to the printed page is only at the foot of the ladder, making a start toward progressive improvement and to higher standards of taste.

The radio industry is standardizing its market by the minimum price of reliable receivers which it offers and by the character of its principal broadcasting programs. We would not be surprised if radio's largest fortune is still to be made by a manufacturer who designs an ingenious three- or four-tube a.c. set, selling for less than \$35 complete, ready to use, a set offering reasonably good quality of reproduction, sensitivity not necessarily exceeding that of the crystal receiver, and only moderate volume through a fairly responsive loud speaker.

The progressive price reductions which have been made in radio receivers have greatly increased the purchasing power of the consumer's dollar in radio, but no manufacturer has yet dared to sacrifice sensitivity and volume to a degree which would enable him to reach the real mass market, the great two thirds of the American families which earn less than \$2000 a year.

Cleared Channels Threatened Again

The Bureau of Internal Revenue has published the first figures indicating the income of broadcasting stations and organizations during 1927. Ninety-seven broadcasting corporations reported an income of \$73,363,297. Of these, 30 grossed \$66,121,400 with a net of \$9,828,929. On the other hand, 58 reported a gross income of \$7,241,897, with a loss in their operations of \$1,181,127. The group of thirty organizations showing a profit earned almost 11 per cent.

Political dabbling is endangering the stability of the profitable group. If broadcasting is to expand, the operations of those engaged in it must continue to show a profit. But apparently, the Commission has learned very little by experience. Commissioner Sykes recently proposed that WAPI, Birmingham,

Ala., be permitted to operate experimentally on channels now occupied exclusively by KOA, KNX, KJR, and WBZ. Considering that WAPI delivers a fairly strong signal in Springfield, Mass., it is obvious that heterodyne interference would result. Very probably the same is true with respect to the service areas of KOA, KJR, and KNX, although we do not know the facts from actual experience in the latter cases.

During the radio chaos, which the Commission was appointed to cure, the reception of WBZ in Springfield was seriously interfered with by KTNT, Muscatine, Iowa, which is about the same distance from Springfield as Birmingham. Other similar cases of heterodyne complaint which are blithely overlooked by Judge Sykes are KFNF's interference with WJZ, WCFL's interference with WEAJ, KMA's interference with WOR. Why has nothing been learned from the bitter experience of the radio chaos of 1926 and 1927? Must we repeat all this again in order to teach the Commissioners the simple rudiments of allocation? The fact that the Commission voted down

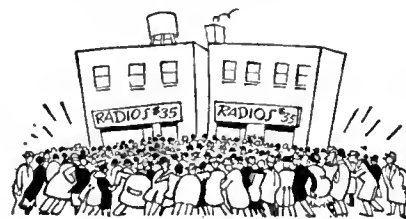

OF RADIO

Less Separation For Our Stations?
50,000-Watt Transmitters Should Be Restricted

the proposal does not make the offense of flaunting experience in the face any less serious.

The Federal Radio Commission itself brought forward overwhelming evidence of the popularity of stations on cleared channels through its questionnaire circulated among farmers and radio amateurs. The 44,141 replies reveal that 72 per cent. indicated as their first choice cleared channel stations, including 100 per cent. of those replying from Connecticut, New Mexico, Vermont, and Wyoming; 99 per cent. from New Jersey; 90 per cent. or more from Delaware, Kentucky, Utah, Mississippi, Arizona, Louisiana, Illinois, Colorado, and Texas; and 85 per cent. from New York. It is notable that only 50 per cent. of those replying from California registered preference for cleared-channel stations. This is accounted for by the fact that the high-grade chain programs originating from the Eastern studios, which make cleared channels the most popular in practically every part of the country, do not reach the Pacific Coast with highly satisfactory quality or at the peak listening hours. Excessively long-distance wire transmission across the country robs the chain programs of their glamor and builds up preference for some of the minor stations, even those whose only good-quality broadcasts consist of phonograph records.

7½-Kilocycle Channels Proposed

The refusal to heed hard won experience is by no means limited to the Federal Radio Commission. We were surprised to learn of the proposal put forward by Louis G. Caldwell, former counsel, Federal Radio Commission, appearing before the Commission in behalf of a number of stations seeking and, no doubt, deserving cleared channels, that a part of the band be compressed to seven-and-one-half-kilocycle channels so as to make such assignments possible. During Hoover's administration of radio, the experiment of seven-and-one-half-kilocycle channels was tried on an exhaustive scale and found wanting. With modern radio receivers, responding to 4000- and 5000-cycle notes, the reception on seven-and-one-half-kilocycle channels would be nothing less than a hopeless bedlam. We are thoroughly in sympathy with the effort to increase the number of cleared channels, but that objective can be attained only by reducing the number of stations occupying the broadcast band. Any proposal to attain additional cleared channels by rendering other channels useless is not worthy of consideration. We are



surprised that such an eminent and competent authority on radio allocation as Louis G. Caldwell should subscribe to such an extraordinary proposal. It could be consummated successfully only if receiving sets with a sharp cut-off at 3500 cycles were introduced. We cannot beg the question of more efficient utilization of the broadcast band by borrowing from Peter to pay Paul.

Very possibly a larger number of radio listeners would be served if ten additional channels were cleared and the entire band below 1200 cycles virtually destroyed, but the broadcast band is too valuable and restricted a territory to make tolerable any proposal which would destroy any part of it.

Station Distribution

While we observe with considerable enthusiasm the increase of 50,000-watt stations, the minimum power which makes for efficient use of a cleared channel, the commission should restrict the total number of 50,000-watt stations assigned to cleared channels in each section of the country before we have an unfortunate concentration of such stations in the New York and Chicago districts. Since the total number which can be accommodated in our broadcast band is strictly limited, 50,000-watt stations should be carefully distributed in all parts of the country. We have, or rather should have, learned from experience the difficulties standing in the way of revocation of licenses and compulsory abandonment of broadcasting facilities to correct allocation errors. But with characteristic disregard of past experience, we are already approaching dangerously close to the saturation point in the northeastern section of the country.



Any limits which are decided upon should be on the basis of equalized geographical areas rather than the impractical five-zone demarcations so far unsuccessfully applied to equalization. The most practical foundation for equalization is to divide the country arbitrarily into 500-mile squares in three belts from north to south, as was proposed to the Commission at its first public hearings immediately after its organization by a representative of RADIO BROADCAST. This would divide the country into 13 equal zones, forming an excellent basis for equalization. The carriers radiated by broadcasting stations cover a specific area regardless of the cities or populations within them. A channel and power assignment is a grant to use a specific channel over a definite area. Consequently, equalized allocation is a matter of dividing channels among equally sized areas, the number of radio broadcasting stations per channel being determined by power and geographical separation.

New R.C.A.-Victor Set-up

The R. C. A-Victor Corporation will, after January 1, 1930, conduct the engineering, manufacturing and sales activities for all the Westinghouse, General Electric, and Radio Corporation of America interests in the broadcasting and talking motion picture field. The resultant increased efficiency in the operations of the radio group means still more intense competition in the quantity production market.—E. H. F.

A RADIO DEALER'S TUBE-TESTER

By JAMES W. BLACKWOOD

AN ESSENTIAL PART of the dealer's and serviceman's equipment has always been some simple tube-testing device. Such an instrument must be inexpensive, portable, and yet accurate enough to judge the quality of a tube. On the other hand, to test all types of tubes for all conditions which might affect their performance requires expensive and complicated equipment which is beyond the needs of the dealer, since he is primarily interested in whether the tube will perform normally in his customer's receiver.

What the dealer or serviceman needs is not some exhaustive test on tubes but a simple test to determine whether the tube will operate at all, and if so how well. He needs to know only three things:

- (1) Is the filament intact?
 - (2) Are any of the elements shorted?
 - (3) Is the tube satisfactory in other respects?
- Either (1) or (2) above cause non-operation; (3) may result in poor operation.

A testing arrangement which the dealer or serviceman can use to classify tubes on the basis of these three general divisions is described in this article. The apparatus can be divided into three circuits: the first, for testing short circuits and open filaments or heaters on all tube types; the second, for testing the operation of three- and four-element receiving tubes; and the third, for testing the operation of rectifier tubes. For convenience, each of these has been arranged to work directly from the 110-volt 60-cycle supply, available to dealers and servicemen everywhere.

Short and Filament Tester

The short-circuit test-set (Fig. 2) consists of two sockets to accommodate four- and five-prong tubes and a system of lamps to indicate when a short circuit occurs. The 110-volt a.c. supply, which is connected across a resistance-type voltage-dividing arrangement, provides the energy necessary to light the lamps when a short circuit occurs. The key, K_1 , in the circuit is for closing the filament or heater circuit through two 10-watt 110-volt lamps in series and gives an indication of open filament or heater circuits.

When key, K_1 , is pressed lamps D and E should both light with equal brilliance, proving the filament or heater circuit is complete. If they do not light, or if only one lights, or if one lights brighter than the other, a short or an open filament is indicated. It is suggested that the owner of the tester have available a convenient method of checking this circuit periodically. This can easily be done by providing old bases with short circuited grid-plate, grid-filament, plate-filament, etc.,

terminals and placing them consecutively in the socket to check the lighting of the proper lamp.

The list of equipment in Table I is offered as a suggestion for those who may wish to build the tester. Any equivalent apparatus, however, will give satisfactory results.

The tube is inserted in the proper socket and the clip attached to the external terminal, in the case of screen-grid tubes. For a normal tube no lamps should light

until the key is pressed after which the two 10-watt lamps D and E should light up with equal brilliance, their circuit being completed through the filament or heater circuit of the tube. If any one or more of the lamps light before the key is pressed, a short circuit is indicated. If, upon pressing the key the two 10-watt lamps are not of equal brilliance, a short circuit is also indicated. The 10-watt lamps will usually burn very dimly when the key is pressed since they are in series across the 110-volt circuit and have, therefore, only 55 volts each.

If, before either key is pressed, any lamp or lamps light the trouble may be found from the following table:

Lamps lit	Type of short
A only	Grid-cathode (control grid)
B "	" " (control or screen grid)
C "	Plate-cathode
A and B	Screen grid—control grid
A and C	Control grid—plate
B and C	Grid-plate (control or screen grid)
E only	Heater—cathode
A and E	Heater or filament—control grid
B and E	Heater or filament—grid (control or screen grid)
C and E	Heater or filament—plate

To test the actual operation of a tube, after it has been determined that there are no shorted elements or an open filament or heater circuit, the circuit shown in Fig. 1 is used. It is a modification of that published in January, 1929, RADIO BROADCAST.

The filament (or heater) is provided with raw a.c. from a transformer. At the same time a.c. voltage is put on the plate. On the positive half cycles the tube takes current which flows through resistors (R_2 and R_3) which puts a negative bias on the grid of the tube. Thus a certain plate current flows. When a key (K_1) is pressed part of this resistance (R_2) is shorted out of the circuit, thereby changing bias and changing plate current. This change in plate current may be taken as a measure of the value of the tube.

With a 15-milliamper full scale meter, M_1 , in the plate circuit, using bias resistors of approximately the values given, all types of tubes can be tested with satisfactory results. A 10-watt, 110-volt lamp, L_1 , used as a protective resistor is included in the circuit to protect the meter in case a shorted tube is accidentally inserted in the socket. A plate-filament or grid-plate short in a tube inserted in this tester will cause the 10-watt lamp, L_1 , to light and the meter M_1 to vibrate slightly about the zero adjustment, the needle following the 60-cycle current passing through the meter. However, it is recommended that in every case tubes be tested for short circuits before inserting in this tester.

The circuit requires a special transformer having a 100-volt primary and a secondary tapped at 1.1, 1.5, 2.5,

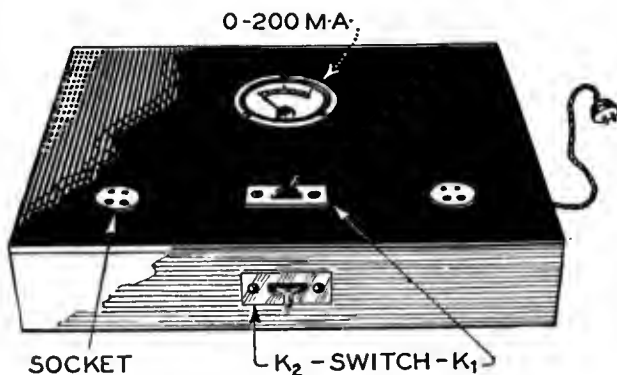

This drawing shows the layout of parts on the panel of the rectifier tube tester.

Table I

R_1, R_2 —Two Carter resistors, type II, 20-ohm
R_3 —One 80-ohm resistor (Two Carter type II were connected in series)
R_4 —One 300-ohm Electrode resistor, type B
A, B, C—Three dial illuminating lamps and sockets, 6-volt, 0.1-ampere
D, E—Two lamps and sockets, 10-watt, 110-volt
K_1 —One key or switch, S.P.S.T. (Push button will do)
K_2 —One General Electric toggle switch, single-pole (Catalogue No. 269943)
S_1 —One tube socket, X type
S_2 —One tube socket, five-prong (Y type)
One adaptor, c-199 (ux-199) tube to x-type socket
One adaptor, c-11 (wn-11) tube to x-type socket
Two clips for connecting to control grid
Two fuses, five-ampere
Box, panel or circuit board.

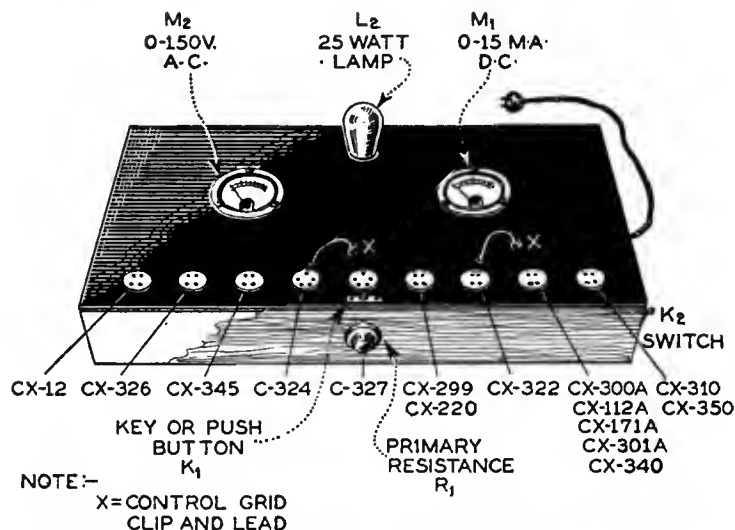

The arrangement of tube sockets, meters, voltage control, etc., of the tube-tester is indicated in this panel layout.

3.3, 5, and 7.5 volts to supply the various filament voltages to the different types of tubes. The American Transformer Company (Amertran) has manufactured such a transformer on special order and other transformer manufacturers are also equipped to do the same thing.

In operation the variable resistance, R_1 , in the 110-volt lead is varied until the a.c. voltmeter, M_2 , across the transformer primary reads 100 volts with the tube inserted in the socket. This insures correct filament and plate voltage on the tube being tested at various a.c. line voltages. The shunting lamp, L_2 , across the transformer primary is to reduce the size of the series resistor required for some of the low-filament-consumption tubes and also serves as a pilot lamp to indicate that the set is turned on.

An alternative method of filament lighting is shown in Fig. 4. All filaments are connected in parallel across the secondary of a transformer having a 110-volt primary and a 7.5-volt, 3-ampere secondary. In this case the primary voltmeter and resistance control change only the plate voltage to the tube, the filament voltage control being obtained from two series filament rheostats, R_4 and R_5 , and read on a two-scale voltmeter, M_3 . It is very important to adjust the rheostats R_4 and R_5 to maximum resistance before inserting any tubes. Two rheostats are provided, one for low- and the other for high-current tubes. Because of the voltmeter current the 50-ohm rheostat, R_4 , provides all regulation necessary even for 60-mA. tubes.

Operation of Tester

The operation of this tester will then be as follows: In the case of a tapped transformer, the tube is inserted in the proper socket and the resistance R_1 is adjusted so that voltmeter, M_2 , reads 100 volts. The plate current reading as shown on M_1 is then noted both before and after closing the key, K_1 . With the untapped transformer (alternative method), rheostats R_4 and R_5 are first set at maximum resistance value. The tube is then inserted in the proper socket and R_4 and R_5 are adjusted to give the correct filament voltage as shown on meter M_3 . Resistance R_1 is then changed to make meter M_2 read 100 volts and from then on procedure is just as in the first case.

It will be found that the tube readings are dependent of the way in which A and A_1 , the plate voltage supply connections, are made to the a.c. supply and filament transformers.

These leads should be reversed until the highest readings are obtained, in order to obtain results comparable to the following table. The difference is especially noticeable in the case of tubes with a 7.5-volt filament.

In testing the tubes with higher readings on the meter M_1 it will be found that as the

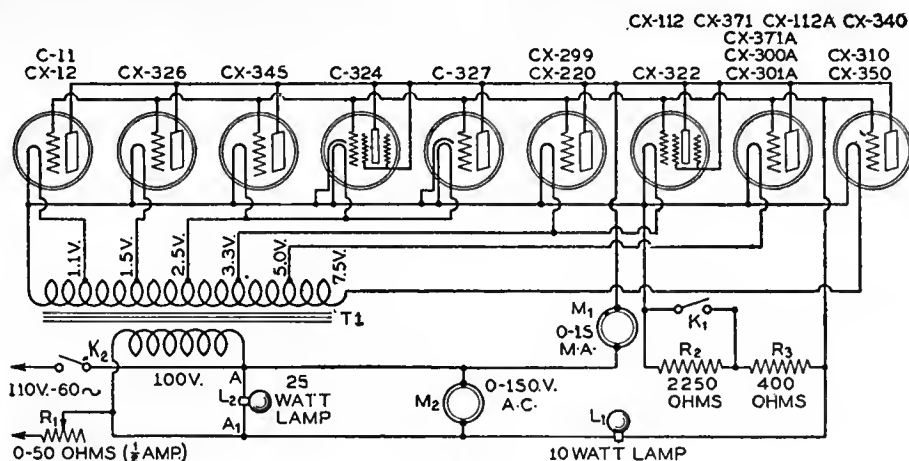

Fig. 1

10-watt lamp becomes slightly heated, the meter reading will decrease slightly. This is entirely caused by the lamp and

tained. Variations in the values of biasing resistor, transformers, meter calibration, etc., will cause some changes in the result.

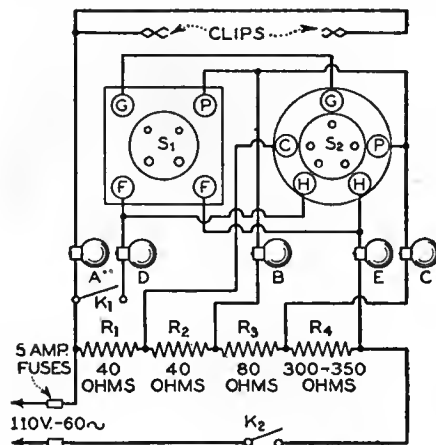

Fig. 2

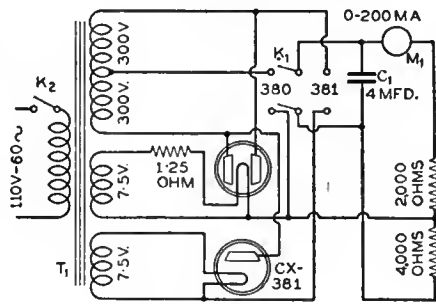

Fig. 3

should not be construed to mean any defect or abnormality in the tube being tested. A table of approximate changes in Cunningham tubes is given here, this table being by no means a criterion but merely to suggest the results to be ob-

Tube	Average Plate Current Values for Tubes	
	K_1 Open	K_1 Closed
CX-11	1-1.5	2-2.5
CX-12	1-1.5	2-2.5
CX-326	1.5	4
CX-345	3	11
C-324	1	2.6
C-327	1.5-2	3-5.5
CX-299	1.5	3
CX-220	2.5-3	5.5-6
CX-322	2	4-6
CX-112	2	6.5-7.0
CX-301A	1.7	4.5-5.0
CX-340	.7	1.7
CX-371	3.5-4	12-13
CX-371A	3.5-4	12-13
CX-300A	1.5	3.5
CX-310	2	6
CX-350	3	10.5
CX-112A	2	6.5-7.0

For constructing the test set a suggested layout is drawn in perspective, for quick work and convenience it is essential to have one socket for each of the groups of tubes indicated on the diagram. It is seen that for the screen-grid tubes the screen grid is connected to the plate making it a three-element tube for purposes of this test. For this reason it is necessary to use a separate socket for screen-grid tubes since on them the control-grid connection is on top and the screen grid is connected to the usual grid terminal of the socket.

The equipment listed in Table II was used in the experimental model but any equivalent apparatus will give satisfactory results.

Table II

- T₁—One special filament transformer, 20-watt capacity and having a 7.5-volt secondary with taps at 1.1, 1.5, 2.5, 3.3, and 5.0 volts. Primary wound for a 100-volts 60-cycle supply and secondary delivering above voltages at rated primary voltage. (American Transformer Company.)
- R₁—One variable resistor, 50-ohm, 500-mA. (General Radio 50-ohm rheostat type 214)
- L₂—One lamp, 25-watt, 110-volt
- L₁—One lamp, 10-watt, 110-volt
- M₂—One Weston 476 n.c. voltmeter, 0-150 scale.
- M₁—One Weston model 301 milliammeter (d.c.) 0-15-mA.
- Six—Sockets, CX type
- Three—Sockets, live-prong
- K₁—One S.P.S.T. switch or key (push button will do)
- R₂—One Electrad resistance, type B, 2250-ohm
- R₃—One Electrad resistance, type B, 400-ohm
- Two—Clips for connection to screen-grid tubes
- K₂—One General Electric single-pole tumbler switch (Catalogue No. 269943)

For the alternative method of filament supply, the following changes would be made in the apparatus requirements:

- T₂—One Thordarson type T2230 filament transformer having a 7.5-volt, 3-ampere secondary and a 110-volt primary
- M₃—One Weston model 528 a.c. voltmeter with two scales of 4- and 8-volt ranges
- R₅—One General Radio type 214 rheostat, 7-ohm, 2-ampere
- R₄—One General Radio type 214 rheostat, 50-ohm, 1/2-ampere

The rectifier test consists in operation of (Concluded on page 171)

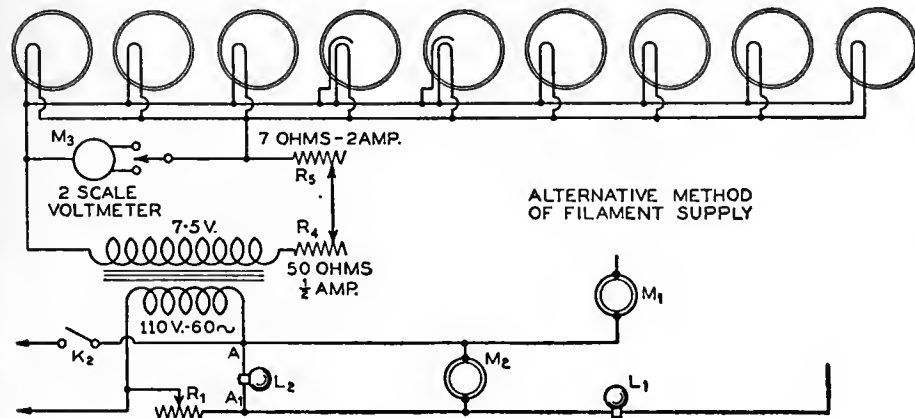

Fig. 4

HOW WE LOOK AT SERVICE PROBLEMS

By MILTON B. HAGER

MOST SERVICE articles which we have read in worth-while radio publications have been written either by a radio engineer or by an executive of a high-grade independent service organization. Although this article has been written by an engineer, the author has been actively engaged in radio installation and service work for one of the largest radio retail chains in the East. Therefore, an attempt will be made to consider service problems from a slightly different angle. On the other hand, it is not intended to lay down an iron-bound set of rules for dealers to follow, but rather to give them ideas which they may adapt to their own needs in their own localities.

Regarding Installation

First, the matter of installing sets will be considered. In this connection we have found that the most economical method of delivering receivers is to send out a light truck with as many sets as may be handled at one time, using two men on the truck. As it takes a good man to make more than four installations in an eight-hour day, the maximum load for the truck for a full day's work would be eight receivers. Throughout the day the men split up so that only one man works on the actual installation of any one set.

Some dealers fit up a special truck for installation work and equip it with all sorts of special apparatus for facilitating the work. However, we have found that this is not necessary. We carry a small kit which contains a few tools and the necessary accessories, such as antenna wire, insulators, ground clamps, etc. We also have a few odds and ends of lumber and some short lengths of bamboo, as these often simplify the work when erecting an antenna on the roof of an apartment house.

When working in an apartment house district a ladder is not always a necessary piece of equipment as a step-ladder, which may be borrowed almost anywhere at any time, will usually give access to the roof. Of course, one-, two-, and three-family houses present problems of their own but even here we have found that a convenient ladder appears with pleasing regularity. In the case of two- and three-family homes tall clothes poles are common. These make an excellent antenna mast and are usually fitted with spikes strong enough to permit the average able-bodied man to reach the top.



"A convenient ladder appears with pleasing regularity."

Above everything else our servicemen who work on installations are cautioned *not to drive nails in a roof*. Failure to follow this rule would cause considerable damage to customers' houses and would give the dealer a poor reputation. Our servicemen are also told not to solder joints in the antenna, lead-in, or ground wire. It is both difficult and inconvenient to make a good soldered joint out of doors and we have found that well-taped, clean, mechanical joints are just as satisfactory. For the



"Some people like company."

ground connection we usually use a radiator, but we make sure that all paint or rust has been removed from the pipe before applying the ground clamp.

The customer must be pleased and this means that the serviceman must watch his P's and Q's while working inside the house. He should keep his hands clean. He should treat the customer with courtesy and respect at all times. If it is found necessary to move furniture, he should ask permission, and then, when he is finished, things should be put back in the order in which they were found. Before leaving he should also instruct the customer in operating the set and at the same time make sure that everything is in good working condition. If it is a c.o.d. installation it is also necessary for the serviceman to watch the collection. In this case the best rule to apply is, "Be courteous but advise the office at once in the event of any misunderstanding."

Routine Calls

Every dealer has a great many service calls which of necessity must be scattered throughout the day to meet the convenience of the customers, noon and late afternoon calls being the most numerous. These calls can be made profitable only when they are handled with care. It is necessary to route your calls carefully to save time and mileage. Don't bunch your calls but spread them out over the week. One must be reasonably prompt, but remember that you can't have six servicemen on Tuesday, none Wednesday, and two on Thursday. It is also wise to concentrate on service calls in wet weather when it is unwise to attempt putting up antennas. Your men should be instructed to make all calls short but consistent with courtesy and service. On an average it will be found that calls do not take more than one half hour each and if care is taken in centraliz-

ing the work of each serviceman to a particular portion of the city very little time will be lost between calls.

From the viewpoint of efficiency it is highly important that the outside servicemen be properly equipped. Every man should be provided with a reliable set-analyser, and the dealer should make sure that he knows how to use it. We use one of the most inexpensive set-testers on the market but have found that it answers perfectly in ninety per cent. of the cases. Twenty-five dollars should cover the cost of the individual equipment that a serviceman uses when he is out of the shop. Besides the set-analyser and small tools each serviceman should carry a pocket voltmeter, a battery tester, and a complete set of tested tubes.

Another principle which we have found important in servicing receivers is not to attempt making any extensive repair in the customer's home. If a test indicates that the work could be performed best in the shop the serviceman should take the chassis, power pack, loud speaker, or the whole works, if necessary, to the shop for repair. Incidentally, what the customer doesn't see can't cause comment.

Servicemen should also be trained in the way they should talk to customers regarding their receivers. The customer should be told that most standard sets are good value at the time of sale and that he (the serviceman) intends to repair the set so that it is capable of giving as good service as when it was new. Most people appreciate good service, and good service begets confidence.

Free Service on New Sales

In addition to his regular service business the dealer must give equal consideration to another form of service which may seem less profitable but which is just as important—the free service on new sales. We back the manufacturer's guarantee and in many cases service both set and tubes for a period of six months without additional charge. We find that the tube service in particular is a big factor in making your set sales stick. All these free service calls, of course, should receive just as prompt attention as the paid calls.

Servicemen must be selected with care. RADIO BROADCAST published an article (April, 1929, issue page 405) giving a good stiff examination. Get a copy of this article and then find out how your men measure (Concluded on page 188)



"Before leaving he should instruct the customer in operating the set."

MATCHING IMPEDANCES

THE TRANSFER of electric power from one place to another, or from some source to a load is continually taking place and the phenomenon no longer excites any public interest. On the other hand, this transfer of power is the engineer's job; he spends his days and nights trying to get either more power from a given source, or the same amount of power at greater efficiency.

In a radio set power is taken from a tube and put into a loud speaker; in an oscillator the power is taken from the tube and put into an antenna.

What are the factors the engineer deals with? How can he adjust matters so that he improves the power output, or the efficiency?

Consider the circuit in Fig. 1. Offhand it looks like a very simple series circuit consisting of a generator, E, and two resistors, r and R. That is exactly what it is, but at the same time it is the fundamental power circuit and may represent not only a battery without resistance feeding current into two resistors, or a dynamo with an internal resistance, r, feeding power into R, or a vacuum tube with a plate resistance, r, feeding power into a load resistance R. When the switch is closed on this circuit, current flows from the source, E, into the two resistors. A certain amount of power is required to force this current through the resistors; this power is numerically equal to I^2r for the power in the resistor r, and I^2R for the power used up in the load.

Now if we could make a generator or a tube without internal resistance, all the power coming from it would be usefully employed in the load, R, but actually this is impossible. Some of the voltage, E, is used up in the internal resistance of the source, whether it be a battery, a generator, or a tube, and the remainder is used in the load.

The first thing to do is to calculate by Ohm's law the current in the circuit, $E/(r + R)$; then calculate the power used up in the two resistors, I^2r and I^2R ; then, in order to find out how efficient the system is, calculate the ratio between the power usefully employed (that in R) to the total power available. Thus, if all the power were used in R (no internal resistance), the system would be 100 per cent. efficient. Such is never the case. Finally we should calculate the voltage across the load and across the internal resistance (Ir and IR).

In the Data Table we have assumed a potential of 100 volts and a generator resistance, r, of 10. Using these values we filled in some of the values as the resistance of the load, R, varies from 1 to 50 ohms, i.e., from one-tenth to five times that of the load. The other values should be calculated and filled in and the data plotted against either load resistance or against the ratio between the load resistance and the internal resistance (R/r).

Analysis of Data

Such calculation and plotting of data is the first half of many experiments; the remainder must be devoted to an analysis of what has happened. One of the first things to note is that the power taken from the generator decreases as the load resistance increases, but that more and more power is used in the load, and less and less is wasted in heating the generator. Note that when the load resistance, R, is equal to the internal resistance, r, the greatest amount of power is taken by the load and that no further adjustment of the latter results in greater power being used in the load. At this point half the total power taken from the source is used in the load and half in the source; the efficiency is 50 per cent.

As the load resistance is increased beyond this point the power in both load and generator decreases—but the efficiency increases. In other words, the power usefully employed in the load rises from a low value to a maximum and then decreases; power wasted in the generator steadily decreases; of the total amount of power taken from the generator, more and more is usefully employed as the load resistance is increased, which means simply, that the efficiency of the system as a whole increases as the external or load resistance increases.

Now an engineer usually has one of two things in his mind when he designs power transfer apparatus. Either he wants the maximum possible power to be taken from a source and transferred to a load; or he wants the transfer of what power he gets to take place at the highest possible efficiency. Often he compromises between power output and efficiency. If he has control over the load resistance he can get maximum power into it by making it equal to

the generator resistance; he can get maximum efficiency by making it high in comparison to the load resistance.

Adjusting the Load

Suppose, however, that the engineer has no control over the load resistance. Suppose, for example, it is a 600-ohm telephone line which must be fed with audio-frequency power from a 6000-ohm vacuum tube. Clearly a loss in power will take place compared to the transfer possible if the tube were 600 ohms or the line were 6000. What can be done?

A transformer can be interposed between the tube and the line which will enable maximum power to be transferred provided it has the proper turns ratio. In this case the ratio of secondary (load side) to primary (tube side) would be $\sqrt{6000/600}$ or about 3.16. Then, so far as the load is concerned, the tube resistance is stepped down so that it could be re-

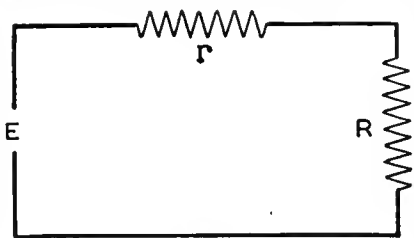

Fig. 1

placed by a 600-ohm tube and the transformer thrown away, and, so far as the tube is concerned, the line resistance is stepped up to 6000 ohms. The only loss in power in such a case is the loss in the transformer itself, which is small if the latter is properly designed.

Matching Impedances

The business of making the resistance of the load equal the resistance of the generator is called "matching impedances" and many thousands of transformers have been designed for this purpose. In the case above, the load and generator impedances were pure resistances. If the generator or load contain some reactance, due to capacity or inductance, the problem is more complex. Suppose the generator, for instance, had an inductive reactance of 10 ohms. To get maximum power into the load, it would be necessary to match the resistances, and to have the load have a capacity reactance of 10 ohms, to balance out the inductive reactance in the generator.

Generally speaking, when the power is small—a few watts, perhaps—engineers match im-

Data Table

$E = 100$ volts; $r = 10$ ohms; $\text{Eff} = \frac{PL}{PL + P_g}$

R	R + r	I	PL	P _g	P _L + P _g	R _g	EL	Eff
1	11	9.1	84	830	913	91	9.0	9.27
2	12	8.34	140	700	840	83	16.7	16.7
4	14	7.15	204	510	714	71	28.6	28.6
6	16							
8	18							
10	20	5.0	250	250	500	50	50	50.0
15	25							
20	30							
30	40							
40	50							
50	60	1.66	138	28	165	17	83	83

$PL = I^2R; P_g = I^2r; \text{Efficiency} = \text{Eff} = \frac{PL}{PL + P_g}$

pedances if possible. Maximum power transfer is of greater importance than great efficiency. When the power is high, however, as a generator supplying lighting and heating power to a city, the efficiency must be high or the generator will burn up. At 50 per cent. efficiency (maximum power output), as much power must be dissipated in the generator as is used in the load. When the power is small, efficiency does not matter so much.

Voltage vs. Load Resistance

The higher the load resistance the greater the proportion of the total voltage available that appears across the load, and the less

across the generator. When the load and the generator resistances are equal, there is as much voltage on the load as on the generator. The sum of the voltages across these two resistors must equal the total available voltage.

Power Output from Tubes

The greatest power is taken from a tube and used in a load, when the resistance of one is exactly equal to that of the other. The greatest undistorted power, however, is transferred from a tube to a loud speaker when the latter has twice the resistance (radiation) of the tube. After you have plotted the data in the table, note how little power is lost by making the load speaker have twice the resistance of the tube compared to the power obtainable when the resistances are equal. Note how little power is lost if the load has even five times as much resistance. From this you can gather that many of the articles and statements in popular radio journals about the importance of properly matching impedances are exaggerated. As a matter of fact doubling, or halving, the power from a tube into a loud speaker is just about audible to the average ear.

In an amplifier which is designed to increase the voltage and not the power, the impedances are not matched. In order to get the greatest voltage out of a low-impedance device, it is necessary to work it into a very high resistance so that of all the voltage available, the greatest part will appear across the load resistance. Thus in an a.f. amplifier the plate circuit works into a very high impedance, sometimes a straight resistance, as in a resistance-coupled amplifier, or the primary of a transformer if a step-up in voltage between tubes is desired. This primary impedance is usually several times greater than that of the tube out of which it works. This impedance must be high at the lowest frequency to which the amplifier is required to transmit without undue loss. Then at all other frequencies, the impedance will be still higher.

If the load has twice the resistance of the tube, three-fourths of the total voltage available will be used up across the coupling device, and hence will be applied to the next tube. If a transformer has an inductance such that at 100 cycles its reactance in ohms is three times the resistance of the tube, nearly 90 per cent. of the voltage at that frequency will be impressed across the transformer because of the fact that the voltage across the transformer and that across the tube are out of phase by 90°. At any other frequency the difference of transmission can be no greater than 10 per cent. (because the maximum transfer is only 100 per cent.), and thus a good characteristic is possible.

Problems

1. A tube (171) has a voltage of 26 (r.m.s.) applied to its grid. This voltage is multiplied by the "mu" of the tube, 3, and appears in the plate circuit as 3×26 . The resistance of the tube is 2000 ohms. Into what resistance should the tube work to transfer the maximum amount of power to the load? What will be the power then? What will be the voltage across the load? Across the tube?

2. The maximum "undistorted power" is transferred from tube to load when the latter has twice the resistance of the tube. What then are the power, the voltages across tube and load, assuming same data as in Problem 1?

3. An amateur transmitter oscillator can put 100 watts into an antenna through an appropriate coupling transformer. If the antenna current is one ampere, what is the resistance of the antenna?

4. An electrodynamic loud speaker has a very low resistance (15 ohms). Suppose it is connected to a power tube capable of an output of one watt and that by means of a step-down transformer 90 per cent. of this power goes into the loud speaker. What is the current in the loud speaker winding?

5. A loud speaker is properly matched to a 2000-ohm tube so that maximum power is transferred. Now a 10,000-ohm tube is put in the socket. What proportion of this tube's power is being transferred to the load? A good way to solve this problem is to assume some voltage, calculate the power in the loud speaker and the total power taken at this voltage. The proportion of the power usefully employed is the power in the loud speaker divided by the total power.

6. What transformer ratio must be used to connect the 10,000-ohm tube to the loud speaker for maximum power transfer?

Answers to problems given on this sheet will be found on page 179.

ELECTRONS AND TUBE TESTING

EVERYONE KNOWS that the electron is what makes the wheels in a radio vacuum tube, and hence in a radio receiver, go around. But servicemen, engineers, and others who know a lot technically about radio, are only on hazy terms with the electron itself, even though they know it by name and talk about it as if they were the best of acquaintances.

What is the electron? How big is it? How many are there? How fast do they travel? When a tube gets older, do the electrons get tired, or what?

The electron and its positively charged companion, the proton, are the fundamental building blocks of the universe. For many years it was thought by scientists that all matter was composed of atoms which were more or less all alike. Then it was discovered that the atoms were not all alike, but that there were about 90 different kinds of them corresponding to the 90-odd elements like gold, hydrogen, mercury—to mention three elements existing commonly in the three states of matter, solid, gaseous, and liquid.

Finally it was learned that these 90-odd atoms were all made up of different numbers and arrangements of electrons and protons. The protons are all in the very heart of the atom; some of the electrons are there too, probably, and the rest are at some distance from the protons but held to them by the attraction existing between these two oppositely charged particles.

How large is the electron? Well, everyone has seen oil films on the street. It is possible to get an oil film about one half a ten thousandth of an inch thick. Atoms must be at least this small

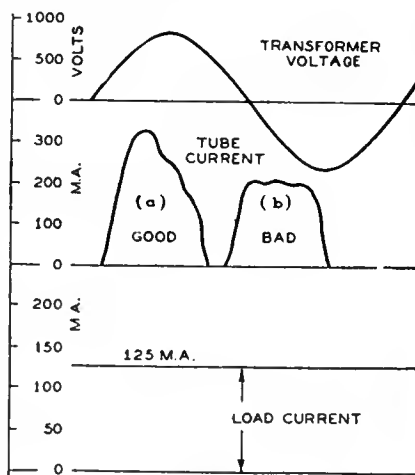

Fig. 1

tubes like the 280 and others which burn with a dull red glow are coated with oxides of rare earths of barium, cesium, etc. They require but little heat before the electrons go shooting off into space and looking for something positive to hang onto, so to speak.

The better the filament the more electrons; the more positive the plate the more electrons arrive per second, each carrying its negative charge or burden of electricity. When a tube gets old, its supply of electrons becomes exhausted, i.e., all the active material is used up.

Consider a single-wave rectifier tube which carries current when the plate is positive with respect to the filament. In some filter circuits the current taken from the tube at some instants may be as high as three times the steady current required by the radio receiver. If there are not enough electrons per second available to take care of this high drain, the curve of tube current output against transformer secondary voltage will flatten out and the output current curve will not look like the input voltage curve. Furthermore if you measured the resistance of the tube you will find that it has increased.

In Fig. 1 are the curves from a good and a poor rectifier tube. Now a flat curve like that in (b) is difficult to filter; therefore when the rectifier tube gets old, it not only refuses to supply the required voltage and current to the set because its resistance is high, but it also becomes difficult to filter and the loud speaker hums.

Now consider a power tube, a 245 for example. The steady plate current with no a.f. signal is about 50 milliamperes. Now if an a.f. signal comes along that has a peak voltage value equal to the C bias on the tube, the current at that instant may be twice the steady value or 100 milliamperes. Suppose, however, the tube is old and that, while it can supply 60 or 75 milliamperes, it cannot supply 100. Such a tube will function properly so long as the volume is not turned up to the point where the tube can no longer supply the peaks of plate current when the grid voltage becomes high. Then the output will begin to break down, and the loud

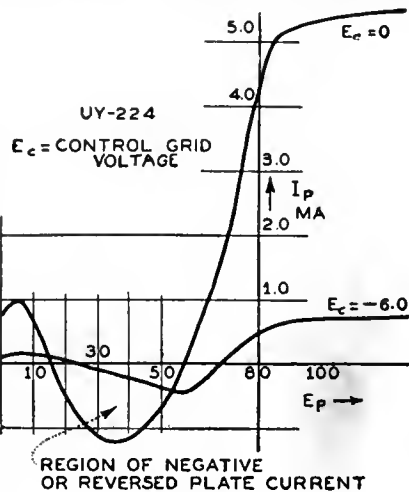

Fig. 4

passages sound as though they fell over themselves in trying to get through the system. They have a top-heavy effect. The trouble is that the source of electrons has been partly exhausted.

The effect is shown in Fig. 2 where e_g is the input grid voltage and i_p is the output a.c. plate current. Whenever this output current does not follow exactly the grid voltage, distortion enters the system. A magnified picture of this distortion is shown in Fig. 3.

Screen-Grid Tube

Many of the electrons which leave the filament never arrive at the plate. They either return to the filament or congregate out in the inter-electrode space. These electrons are negative and the little invisible cloud (called a "space charge") they form is negative. Therefore, they repel any electrons which come near them, and because they are between filament and plate they limit the plate current.

Now a second grid with a positive charge placed in the midst of this cloud will attract these stray and unhelpful electrons and thereby get them out of the way. Such is the second grid in the screen-grid tube. It is positive and attracts some electrons; there is some screen-grid current. If the plate voltage is high compared to the screen grid, the plate current will be high. Since the sum total of electrons taken from the filament and going to screen grid and plate is more or less constant, the greater the plate current the fewer the number of electrons that stop at the screen grid.

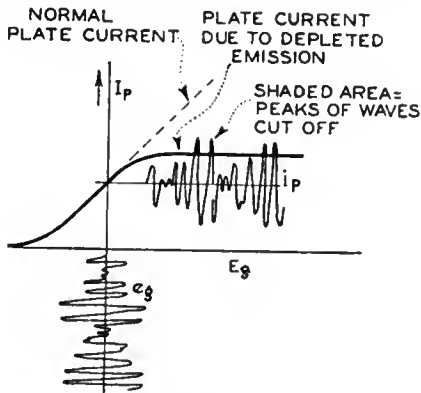

Fig. 2

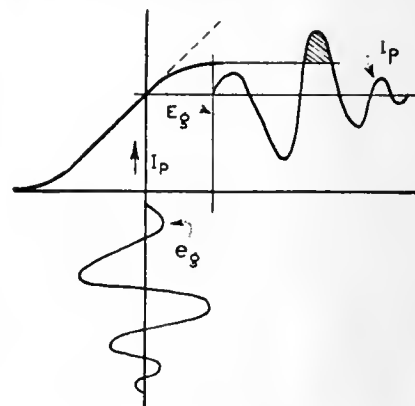

Fig. 3

and electrons must, of course, be much smaller yet. No microscope can see them; we are aware of the electron only when it migrates in company with many billions of its fellows.

If the atoms to which the electrons are attached, are agitated enough, by great heat for example, some of the electrons can escape much as the earth and the other planets escaped from the sun at some very remote time. Because these electrons are negatively charged they are attracted toward any positive body and the more positive the body is, or the nearer the electrons are to it, the faster the electrons go.

If an electron gets up a speed of about 600 miles per second it can escape from a metallic filament. If 10^{16} electrons per second arrive at the plate in a vacuum tube, a plate current meter would read one milliampere. Now this number of electrons (it is actually ten thousand million million) may not seem like a very great number, but take out your watch, and for one minute count just as fast as you can. You may be able to count up to 300 in one minute. Then, if you like to juggle figures, calculate how long it would take all the people of the United States (110 million) to count out this number of electrons.

The milliammeter, then, is a machine for counting electrons in huge blocks. Instead of saying there are so many billion electrons per second flowing out of the plate battery and going through the tube, we bunch them (in motion) into very large groups called an ampere, or a milliampere (one thousandth of an ampere).

The electrons in modern tubes come from paste or active material put on or in a wire which is heated by passing current through it. The idea is to get some material which will give off its electrons easily, so that not a great amount of power must be wasted in heating the filament. The 201A-type tubes and some others use thorium as the active element. Thorium is a relative of radium and gives up its electrons easily. It makes a very efficient filament. Some

Suppose, however, the screen grid and plate have about the same voltage. Now the currents will be approximately equal. An electron, speeded along by this positive grid will go through it and thump the plate. It may knock an electron out of the plate, perhaps one that has just arrived. This electron may go back to the screen grid and if enough of them return toward the filament the plate current will actually go backward; it reverses. This reversed current is said to be due to "secondary emission."

In Fig. 4 is the plate voltage-plate current curve of an a.c. screen-grid tube. Note that the plate current flows even though the plate voltage is zero. Why is this? It is because there is a stream of electrons going to the screen grid which is positive. Some of these go through the screen grid and form a plate current. As the plate voltage is increased, the plate current increases up to a certain point and then begins to decrease. When the two voltages are about equal the current to the plate is actually negative, this means that more electrons are leaving the plate than arrive at it. At higher plate voltages the secondary electrons are attracted back as fast as they leave the plate.

Pentode

If now still another grid is put into the tube and made positive, it will attract these reversing electrons and prevent the plate current going backward. Now we have the heart of the pentode. It is a tube with three grids, the usual signal grid which is maintained negative, a cathode grid which is the grid which cleans up the space charge or cloud of lagged electrons, and finally is the third grid which has about the same potential as the plate. It cleans up the electrons which are reversing their field.

THE KINEMATIC REMOTE CONTROL

By M. B. SLEEPER

Sleeper Research Corporation.

ENGINEERS who have been working on remote control for radio sets have produced a wide variety of exceedingly clever devices. We, at the Sleeper Research Corporation, found that it would be difficult, perhaps impossible, to out-engineer some of the systems already in existence.

As a general policy, anyway, it is always well to forget others when you want to do something original. That was why we went back to pre-war times and set to work on a thirteen-year-old system, originally planned for airplane radio use, to make a piece of present-day merchandise.

There, briefly, is the story of Kinematic remote dial tuning. It isn't designed as a remarkable mechanism that does amazing things. It is only intended to meet a sales manager's requirements as a piece of merchandise. The only remarkable things about it are its simplicity, small size, and low cost.

What the Kinematic Does

Fig. 1 shows a Kinematic control box. There is a dial, the scale of which corresponds to the settings of the tuning condensers. This is rotated by the knob on the left of the box. The right-hand knob regulates the volume control which is mounted in the set. The volume control is the standard Yaxley device fitted with an a.c. toggle switch which is thrown over, when the volume is cut down to zero, to turn off the current supply to the set.

We feel that the proper place for the volume-control resistor is in the chassis—not inside the control box—because it is not good engineering practise to run long leads belonging to the radio circuits, here and there around the house. Moreover, when such an arrangement is employed, it limits the system to the use of only one control box.

Certainly any really useful system must be capable of controlling the set from two or three points, or up to a dozen if they are required.

How It Operates

In Figs. 2 and 3 are top and front views of a standard Sterling screen-grid chassis equipped with the Kinematic driving

mechanisms. The mechanism at the left is geared to the shaft of the four-gang condenser, while the one at the right moves the arm on the variable volume-control resistor. The contact arm, in turn, operates the toggle switch controlling the power.

These devices are referred to as driving mechanisms because, contrary to their

having started, inertia will cause it to turn the condenser too far. By eliminating inertia from the Kinematic device, and designing it to operate in synchronism with the control box dial, at any speed, the tuning condensers can be adjusted to an accuracy of greater than one-quarter of a division on the dial. Still finer settings can be obtained if it is considered necessary, but one-third or one-fourth of a division is sufficient for most sets.

Importance of Accuracy

The extreme accuracy of the Kinematic gives just as perfect and as close tuning at each box as can be obtained by hand at the set itself.

One of the great difficulties with pre-selection devices is the problem of stopping the condensers at a given setting, repeatedly over a period of months, right on the nose of each station. Any kind of contacts are subject to wear, and stops are moved slightly by repeated action, just enough to make a difference of plus or minus one-half the division or more. The result is that the adjustments require frequent re-setting. As this is a service which must be performed by a serviceman, and, as it is due to failure of the mechanism itself, the work must be done at the dealer's expense. As a result the cost of repeated re-settings may wipe out the profit from the installation.

Another thing, beyond the control of the manufacturers—a change in the antenna, the lead-in, or a ground connection—may throw out all the settings. Nor is the frequency of the broadcasting stations absolutely constant. The stations are only limited by Radio Commission regulations to an accuracy of one kilocycle, and, at that, many stations vary beyond this limit. Thus pre-selected settings, no matter how perfect, do not assure perfect tuning.

All these troubles are eliminated with synchronous dial tuning, but they are inherent with remote pre-selection. In this, remote pre-selection differs from hand-operated automatic tuning, for with the hand type of control no harm is done if the selectors do not bring in each station on the peak, for when the selector button is pressed the tuning knob is also within

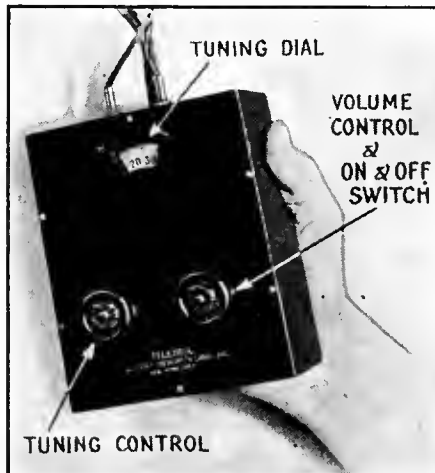

Fig. 1—The Kinematic remote dial tuning unit.

appearance, they are not motors. They simply serve to actuate the condensers in perfect synchronism with the rotation of the dial on the control box, following not only in speed but in degree of movement.

This point is made because, although the driving mechanisms operate in both directions, they are not to be confused with the systems which employ constant-speed, reversible motors. Such motors are controlled by two buttons, one to make the motor turn left and the other to make it turn right. Stations are tuned in by juggling the buttons back and forth.

The disadvantage in this is due to the inertia of the armature. That is, if you want to make the condenser move only one-half a division, and you barely touch the button, the armature does not have time to start up. If you hold the button down long enough to start the armature,

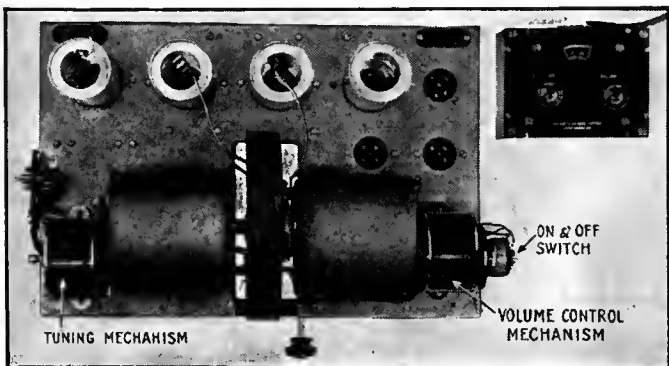

Fig. 2—Top view of standard Sterling chassis equipped with remote control mechanisms.

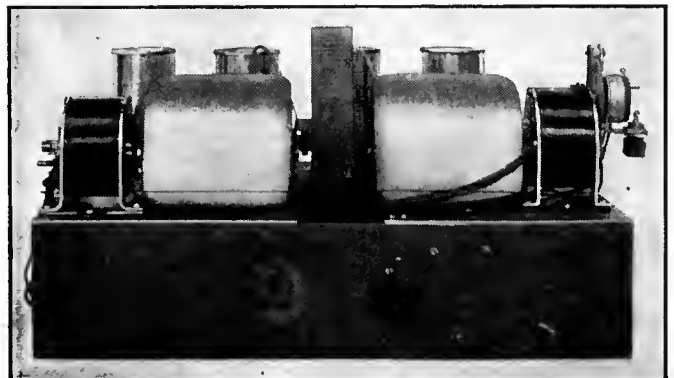

Fig. 3—Front view of chassis shows small size of tuning mechanisms.

reach for making more accurate adjustments.

Show a dealer a likely looking device, and listen for his first question—"How much does it cost?" He wants to know if it is a low-priced convenience for everyone or an expensive luxury for a few.

Discussing remote control, R. H. Langley, director of engineering for the Crosley Radio Corporation said, "Important improvements in the automotive field have not brought corresponding price increases. If remote control is to become a permanent feature of radio sets it must be possible for manufacturers to add it without substantial increase in the cost to the public." In this connection it is expected that the new models, equipped with Kinematics, to be brought out this spring, will cost only a little more—only ten or fifteen dollars—than hand-tuned models. On the other hand, remote control may bring about important changes, to be discussed in subsequent paragraphs, which will make it necessary to spend no more for the complete installation with remote control than for the present types of hand-tuned receivers.

The biggest feature of Kinematic is not seen as much as it is experienced. That is, the device is habit-forming. Just, as from habit, you open your front door at night, and reach for the switch to turn on the lights, so you reach, with little direct attention, for the tuning knobs of the Kinematic, changing the volume, tuning up or down to a program that is in keeping with your mood, or switching the set off altogether. When you have learned to depend upon the convenience of the control, you are conscious of what you accomplish, rather than of the means you employ.

There you have the difference between the gas water-heater which has to be lighted each time with a match, and the type which lights itself when you turn on the water. Kinematic removes the radio mechanism from your consciousness and leaves you with the sense of enjoying music from a source you need not consider.

What About Radio Furniture?

This season, most chassis cost less to manufacture than the cabinets which house them. To put it differently, and in a rather startling way, the companies that make sets and cabinets are more in the furniture business than in the radio business. If they do not make their own cabinets, they are supporting furniture companies larger than their own.

This is not a healthy development in the industry for, in order to permit a wider choice of good cabinets at reasonable prices, the radio equipment is being ruthlessly engineered to lower costs. There are many improvements which are now excluded their cost is put into the appearance of the cabinet.

The trend of design for 1930—and this will be most pronounced by 1931—is to eliminate the necessity for elaborate cabinets by putting the set, enclosed in a plain metal box, out of sight, operating it by remote control.

While it is true that the initial results obtained from 1929 model sets, equipped with screen-grid tubes, show some improvement over preceding types, and although the outward appearance of the new sets is generally more clean-cut and attractive, the result of cost reduction is apparent the moment you dig into the chassis to shoot trouble. This year parts are being hung together by the wiring. No attempt has been made to facilitate the finding of faults which develop all too rapidly. The wiring has simply been moved to the under side of the chassis

where, out of sight, it is done in a most haphazard manner. The coming season will certainly demonstrate the general

need for furniture except to house radio and phonograph combinations. These instruments must be a part of the home furnishings, but the radio set should take its place with the other home electrical and mechanical devices, out of sight.

How It is Installed

The set manufacturer's first question concerning remote control is, "What changes must be made in the chassis?"

With thousands of dollars invested in manufacturing tools, dies, and fixtures, no company can afford to make sweeping changes in the current chassis designs in order to accommodate remote control, no matter how good it is. This is particularly true in the case of controls which require a considerable increase in the overall dimensions of the chassis, for then the chassis cost is increased also.

The driving mechanisms described in this article are so small, fortunately, that they can be fitted on as compact a job as the Crosley receiver. It is necessary to locate the tuning mechanism at one end or the other of the condenser shaft, but the volume and switching mechanism can be put anywhere that space can be found.

Nor is any complicated assembly problem introduced. To avoid the use of the flexible coupling, the large gear is mounted on the condenser shaft. Then, when the driving mechanism is in place, it is moved up until a pinion engages smoothly with the big gear, and the holding screws tightened permanently.

The volume and switching device is a complete unit in itself, so it does not require a special assembly on the chassis. Leads which, on hand-tuned sets, were brought to the volume control and power switch, are connected to these devices now mounted on the driving mechanism.

A separable connection or terminal strip is used for connections from the mechanism to the cable. This circuit is shown in Fig. 4. The wiring is very simple to do because all the control boxes hook on in parallel. Small terminal boxes are provided for the cable connections to the boxes, as it is safer to use this method than to employ ordinary splicing.

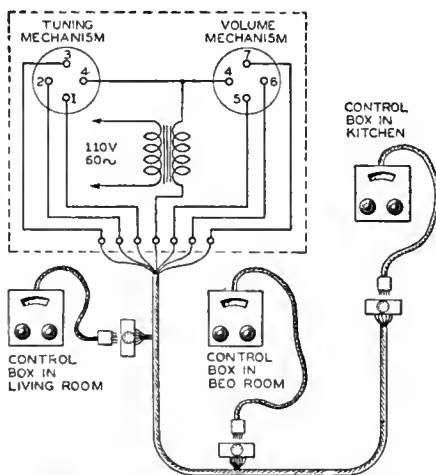

Fig. 4—Diagram showing how the remote dial tuning units are connected with the receiver.

fallacy of cheap construction where it has been carried to an extreme in radio receiver sets.

Scientific development has been brought to a standstill because improvements which would increase the cost of the chassis are prohibited. The use of remote control will permit a part of the present cost of cabinets to be put into better radio equipment. The overall cost to the public will be no higher, but the public will buy more radio and less cabinet. This is easy to understand when you realize that furniture companies entering the radio field buy standard chassis for less than twenty-five dollars, and retail these chassis, fitted into cabinets at two hundred and fifty dollars.

With remote control available there is



JOHN S. GORMAN (Gulbransen): "Although the stock market upheaval undoubtedly may cause a radical readjustment affecting many concerns, we are going full steam ahead."

MAJOR FROST (Radio Manufacturers' Association): "The era of suspicion and distrust among radio manufacturers is over."

HAROLD A. LAFOUNT (Federal Radio Commission): "Expressions from listeners throughout the nation concerning the character of the programs they enjoy should aid the Radio Commission in properly appraising the public service rendered by broadcasters."

J. L. RAY (Radio-Victor): "At no time in radio's short but spectacular history has it been possible to get so much for the radio dollar."

H. B. RICHMOND (Radio Manufacturers' Association): "Fortunately for the average pocketbook, radio receiver design has reached a point where to-day's set does not make yesterday's obsolete."

Much New Business Ahead

Every family that has bought a radio set to which remote control can be attached is a prospect right now. The first sale may include only one or two control boxes. Subsequent calls, after the people have become acquainted with this new device, will bring many sales of additional boxes. Spring and fall moving times will bring substantial extra business in re-installing the control equipment.

Already, many concerns which specialize in wiring new houses for radio are planning to sell Kinematic installations. When houses are wired for remote control, the cable will be led to seven-contact wall plates, into which a convenient length of cord, attached to a control box, can be plugged, just as wall outlets are provided for electric lamps.

New sets, Kinematic-equipped, open another field of sales and installation work for dealers. This can be developed most profitably for there is not only the initial work to be done, but follow-up sales of additional controls.

These are time-plus-profit jobs, requiring no subsequent free service. No routine inspection is needed. There are no brushes to be replaced, armatures to be rewound, grease cups to fill, or adjustments to be regulated—things which must be done free of charge—only clean-cut set sales and installation for which charges can be made legitimately.

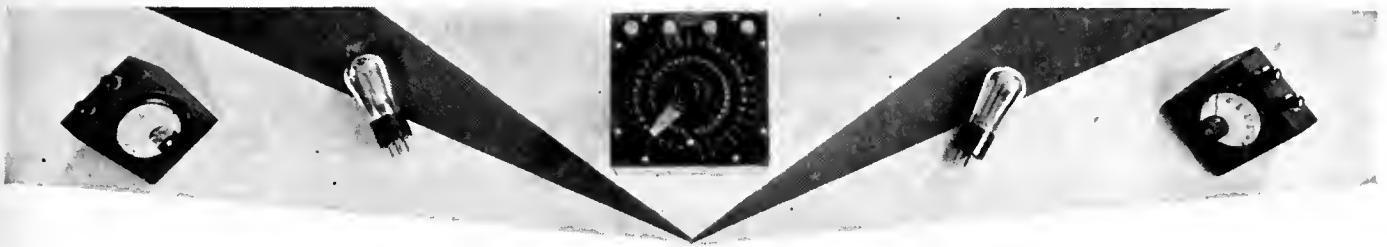

STRAYS FROM THE LABORATORY

A Novel Wavemeter

The picture in Fig. 1 illustrates an interesting and effective addition to the resonance type of wavemeter. This device, which was first described in the *General Radio Experimenter*, September, 1929, consists simply in a small fixed capacity which can be thrown across the variable tuning capacity by means of a push button, and is useful in getting an accurate setting of the meter. (See Fig. 2).

Suppose for example, as in Fig. 3, the variable capacity is equal to C_1 so that the current is indicated at I_1 . Then pressing the push button throws the fixed capacity into the circuit and makes the current equal to I_2 , which, in this case, is numerically equal to I_1 . In other words, at one point on the variable condenser dial, pushing the button will not cause a change in current. This point, C_1 , is taken as the calibration point. At any other setting of C pushing the button causes a change in current.

There is one disadvantage of this type of wavemeter—the tuned circuit is not exactly in tune with the circuit whose frequency is being measured. Therefore, the tuned circuit of the wavemeter has some reactance which will be reflected into the tuned circuit under test. This may change the frequency of the circuit with the result that the reading will not be accurate. This difficulty can be obviated by using very loose coupling, and by changing the coupling as the setting of the wavemeter is adjusted to the proper point.

An International Broadcaster

Down in Heredia, Costa Rica, "the center of America," is a patient amateur, Amando Cespedes Marin. For several years Sr. Marin, who has many medals for proficiency and artistry in photography, has maintained and operated a 7.5-watt amateur radio telephone station on 30.8 meters. Despite such limited power, Sr. Marin's voice and music have been heard all over North, South, and Central America and he has not only secured considerable favorable notice for his station but also for his city and his nation. For some time he has been making a plea for funds with which to enlarge his station and to increase its power.

Contributions have been received in small amounts from many of his listeners in the United States and elsewhere and one enterprising American manufacturer sent him a batch of tubes and a check for \$50. Now the Costa Rican city, Heredia, has given him \$150 and money for telephone lines to the municipal band stand. He has collected nearly enough to bring his power up to 150 watts which should fling his voice into the short-wave receiver of many hundreds of avid listeners. Con-

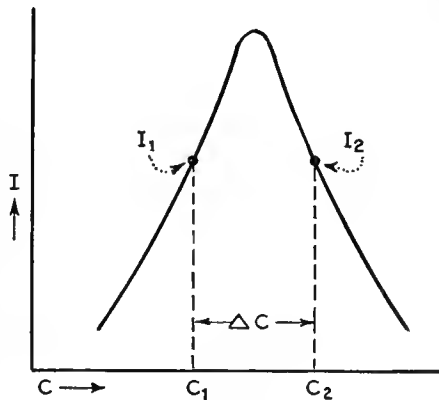

Fig. 3

tributions may be mailed to Sr. Marin and will be appreciated.

An Interesting Formula

An interesting expression in the next column gives the relation between stability in an r.f. amplifier and the circuit con-

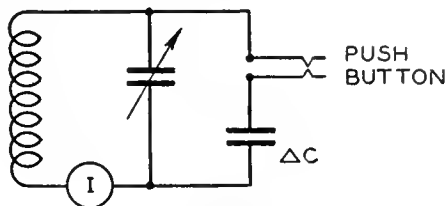

Fig. 2

stants, such as plate resistance, coil resistance, grid-plate capacity, etc. The lowest resistance the tuning coil can have may be found by substituting the circuit constants in this expression at the highest

frequency to be used, viz., 1500 kc. for the broadcast band. The circuit will be stable at all other frequencies. The plate of the preceding tube and the grid of the following tube are connected across the entire coil. Perfect shielding is assumed except that due plate-grid capacity.

$$\frac{C_{gp} \omega G_m}{r \left(1 + \frac{1}{R_p}\right)} = 2$$

where C_{gp} = grid-plate capacity
 ω = $2\pi f$
 G_m = mutual conductance in mhos
 r = high-frequency resistance of coil
 R_p = plate resistance of tube

A "New" Recording System

In October the public press in England was greatly excited by the report of a new invention, made in Germany, having an application in the talking motion picture industry and in the recording of sound for home entertainment. The method consists simply of impressing audio-frequency currents on a pair of electromagnets between which an iron or steel wire is drawn at a constant rate. The wire is magnetized according to the voice modulation, and when the process is reversed the sounds may be reproduced. The time interval between recording and reproduction may be as short as desired.

Some time after the disclosure of the principle and the general hurrah about it in the newspapers, someone discovered that the idea was not new at all but had been invented some thirty years before by Valdemar Poulsen, the Danish radio engineer of world-wide fame. This was then related in the papers and altogether there was quite a hullabaloo.

We remember discussing this method of sound recording with Theodore H. Nakken several years ago. He had worked with it and found it a successful method provided the wire could be made to retain the "sound," which, at the time of the discussion, had not been found possible.

Newspaper clippings about the affair were sent through the courtesy of Lawrence Corbett, formerly of the editorial staff of *RADIO BROADCAST* and now of London, England.

Two New Booklets

Research Papers Nos. 77 and 90 of the Bureau of Standards describe, respectively "A Course-Shift Indicator for the Double-Modulation Type of Radiobeacon" and "A Comparison for the Calculation of the Inductance of Coils and Spirals Wound With Wires of Large Cross Section." The former is by Harry Diamond, radio engineer, and F. W. Dunmore, physicist, and the second by Frederick W. Grover, consulting physicist.

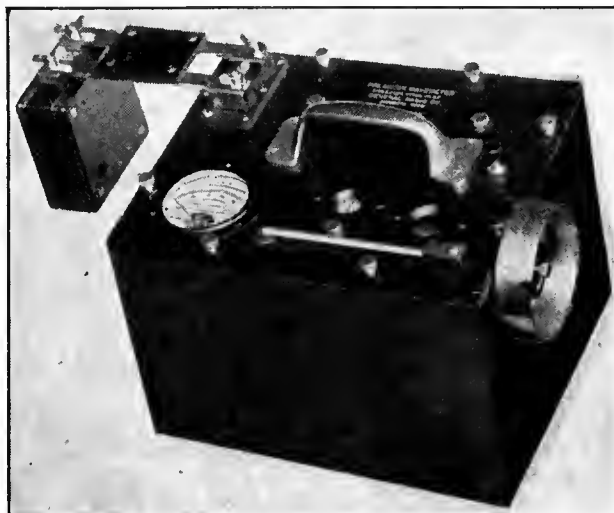
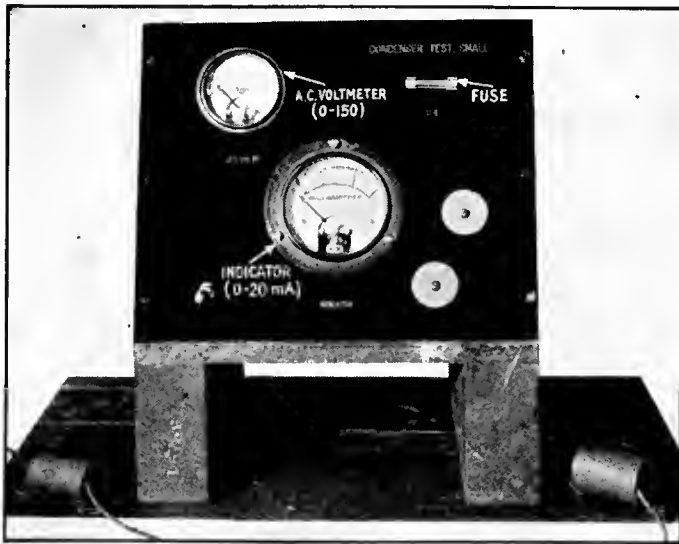

Fig. 1—General view of the new wavemeter developed by General Radio.

A PRODUCTION TESTING SYSTEM

By J. A. CALLANAN

Stewart Warner Corporation



This apparatus measures the capacity of small by-pass condensers. The schematic diagram is shown in Fig. 5.

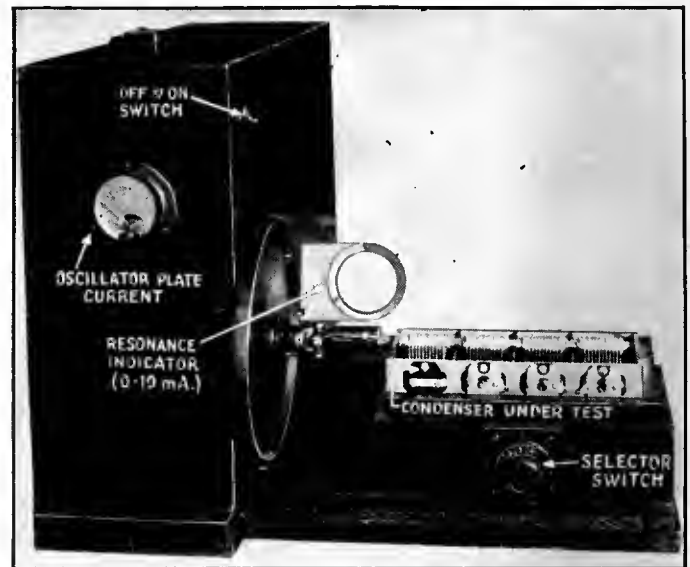

An instrument for rapidly testing gang condensers.

THIS is the first of a series of several articles which will consider the testing of radio parts and receivers from the production viewpoint. In this installment information is given on the method employed at the Stewart Warner Corporation for the testing of condensers used in radio receivers. Furthermore, in presenting these data it has been assumed that the reader is familiar with the more severe percentage tests which are run in the laboratory and from which the inspection department limits are derived.

Without further introduction we will enter into the discussion. To begin with the requirements of production testing are, as we find them, listed in the following table in the order of their importance:

- 1.—The test must be complete and accurate.
- 2.—The test must be quick.
- 3.—The test fixtures must be safe for the operator, as often potentials which might prove fatal are used.
- 4.—The cost of the test fixture should be reasonable.
- 5.—The test fixture must be made so as to be fool proof, and in case damage results to it, easily serviced.

With the above requirements in mind

we can consider the production testing of condensers of the type used in radio receivers. In Stewart Warner sets, which are nearly all of the single-dial a.c. screen-grid type, there are five types of condensers which must pass exacting tests before they are considered satisfactory for use as component parts of the completed receiver.

Of major importance is the testing of the gang variable condenser and the coupling condensers attached to it, and this is probably the most interesting as its requirements are the most exacting. After the condenser is received by the inspection department it is given a visual examination for bent or defective plates and defective construction. It is then placed on a conveyor belt, and upon reaching the first operator the coupling condensers are given a breakdown test at 500 volts a.c. This is accomplished by use of a small step-up transformer with a neon lamp connected in each side of the high-potential winding and two well-insulated circuit test pointers. In this case danger to the operator is guarded against by using a very small transformer which on direct short only consumes from 10 to 15 watts.

After the test described above the con-

veyor takes the condenser to the next operation. The setting of the coupling condensers by the beat oscillator shown in Fig. 1. The test apparatus for this operation consists of an oscillator, an oscillating detector and a conventional two-stage a.f. amplifier. Headphones are used on the output rather than a loud speaker because the operator is not distracted as easily by other noises in the room. In performing the test, the condenser is placed in a jig which has three stops, one opposite each coupling capacitor. The operation merely consists of tightening the set screw on each section, in turn, until its capacitance is correct to place the oscillating detector in resonance or zero beat with the standard oscillator. Standardizing is accomplished by throwing a switch from test to standard position, thus connecting a standard condenser of the desired capacity across the test position; variation is compensated by a small condenser connected across the detector. To sharpen the response and minimize coupling error, the oscillating detector beats against the second harmonic of the standard oscillator.

More accurate results could be obtained in this test by modulating one of the oscillating circuits with say a 1000-cycle

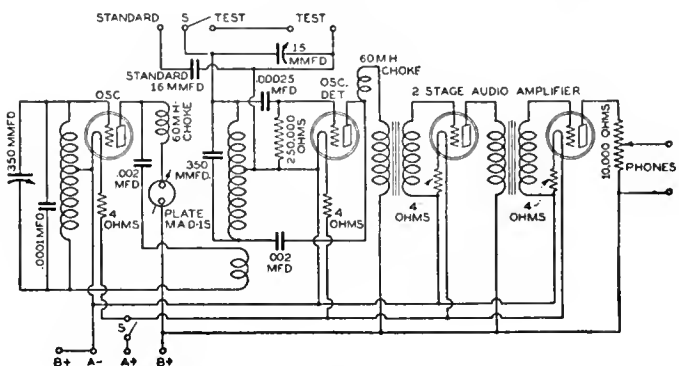

Fig. 1

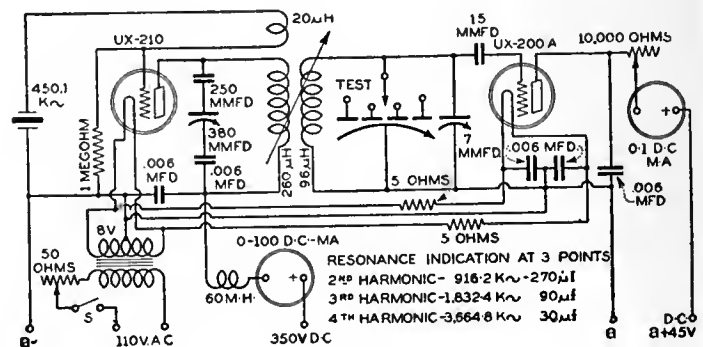

Fig. 2

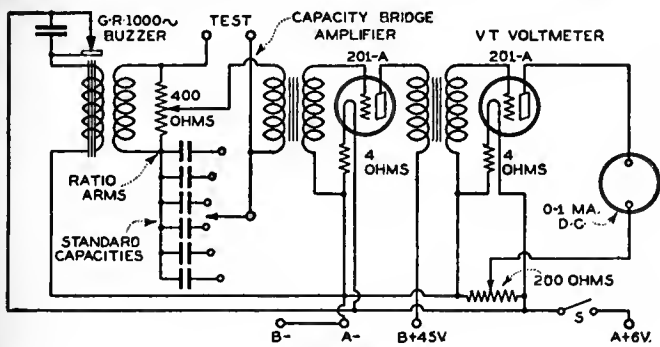

Fig. 3

source and beating against that. However, it was not found necessary because if the circuits are correctly adjusted differences of 0.1 mmfd. can be made to make a note of approximately 100 cycles in the headphones. Also, when using the 1000-cycle modulation there is the possibility of the operator beating either 1000 cycles above or below the standard. This is a 2000-cycle error compared to the more sure zero-beat method with possibly a 75-cycle error. Variation of these condensers in the following operations is prevented by applying a dab of ambroid cement to the adjustment screw. The test set-up uses one 45-volt B battery as a.c. operation has not been found practical.

The Third Operation

The third operation is the testing of the gang condenser sections. The test fixture consists of a 450-kc. crystal-controlled oscillator coupled to what might be termed a vacuum-tube voltmeter. As can be gathered from the picture on page 152 and the diagram, Fig. 2, the condenser with plates open is placed in a jig, a large dial is clamped to its shaft, and the plates are meshed until maximum deflection of the meter denotes resonance with the fourth harmonic of the crystal oscillator (3600 kc.). In our particular case this occurs when the condenser capacity is approximately 30 mmfd. The variation allowed at this point is 0.3 mmfd. or 1 per cent. The four sections are alternately tested at this point by use of the selector switch as may be seen by again referring to Fig. 2. The plates are then meshed further until the meter again deflects, this time at 1800 kc., the third harmonic, and the sections tested as before. The capacity of the condenser at this position is approximately 60 mmfd. and the limits 0.6 mmfd. or again 1 per cent. The plates are then interlocked almost completely, resonance being noted at the second harmonic of the oscillator (900 kc.) and each section is tested again. The capacity at this point is approximately 270 mmfd. and the limits 1.5 mmfd. or somewhat less than 1 per cent.

The potential for the oscillator is supplied by a motor generator and the oscillator output is controlled by the variable condenser in the plate tank circuit. As it is possible to touch this condenser when adjusting the fixture, series fixed condensers are used to guard against a possible shock. The 100-mA. meter is employed to indicate the condition of the oscillator. The 8-volt centertapped filament transformer supplies both tubes while the 10,000-ohm resistor makes possible control of the resonance reading. The small variable condenser paralleled with the test position allows for variation in the tube capacitance when replacements are made. The 15-mmfd. condenser in the grid lead of the vacuum-tube voltmeter provides an automatic control of the resonance dip. A setting is possible with

it that gives the same deflection for each position. This fixture uses a motor generator and one 45-volt B battery, high-potential rectifier systems having been found rather unstable.

Fixed Condensers

The testing of fixed mica condensers of 0.01 mfd. or less is not such a complicated matter. The condensers are first tested for breakdown under conditions similar to those used in testing coupling condensers.

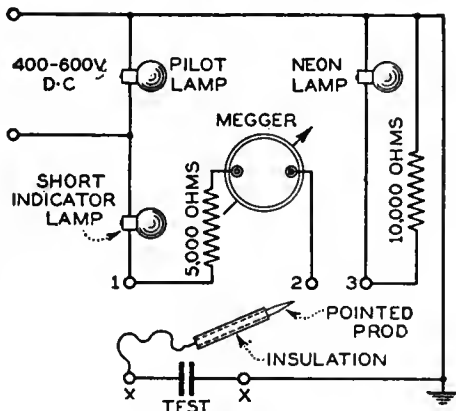

Fig. 4

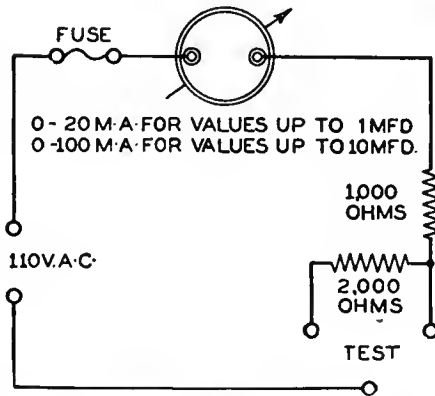

Fig. 5

The two fixed terminals take the place of the test pointers, and, as the condensers used are of the moulded bakelite type they are held in the bare hand while testing. The capacity test, as may be seen from Fig. 3, consists of a conventional bridge circuit actuated by a 1000-cycle source, the sound being amplified and then indicated by a vacuum-tube voltmeter. A dial is attached to the 400-ohm potentiometer with the desired limits painted on it. By selecting a standard of the same capacitance as that which is being tested, the bridge is always balanced at the center of the dial of the potentiometer. The limits are of the same width for all values. It is only necessary for the operator to note that the value marked opposite the selector switch corresponds to the value of the condenser being tested and that the minimum deflection is within the painted limits on the dial. The 200-ohm potentiometer is a sensitivity adjustment on the vacuum-tube voltmeter as, of course, much greater deflections are noted when testing 0.01-mfd. condensers than 0.00025 mfd. units. Operators soon become so accustomed to the deflections noted on this meter that they center the potentiometer dial and then are able to tell whether or not a condenser is within the required limits by the deflection of the meter. The test fixture uses a storage battery and a 45-volt B battery.

Filter Condensers

Filter and by-pass condensers differ only in their values and rated operating potentials in so far as testing is concerned, and so, of course, they are tested similarly. At the start of their journey through the inspection department they are placed on conveyor belts, depending upon whether they are filter or by-pass condensers and the type of set for which they are intended. They are given three tests; the first two, breakdown and insulation resistance are one operation, while capacitance measurement is another. The circuit used for the breakdown-insulation resistance test is shown in Fig. 4. The condenser is clipped into the test position and given a breakdown test by inserting a prod in terminal No. 1. This places twice the rated operating potential on it and should the condenser prove to be defective a red lamp lights, indicating a shorted condition.

(Concluded on page 179)

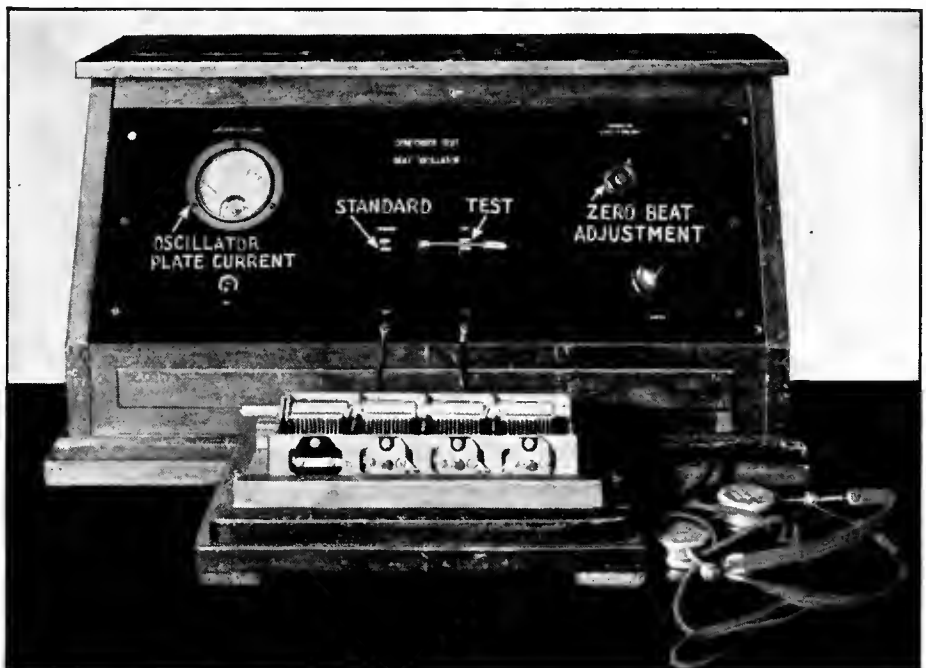

A machine for production testing of coupling condensers.

RESONANCE AND REVERBERATION

By HOWARD E. RHODES

Technical Editor

EXCESSIVE low-frequency response of a loud speaker mounted in a cabinet may be due to one or a number of factors—reverberation, resonance of the cabinet, acoustic coupling between the tubes and the loud speaker, and so on. The subject is one which has been given no small amount of attention, and, to determine what methods are used in eliminating these effects, we asked a number of representative engineers for their comments. In sending out these questions the particular problem we had in mind was the practicability of using some type of sound-absorbing material as a lining in the cabinet. An analysis of the replies showed that the general consensus was that acoustic linings in cabinets are not very effective in eliminating low-frequency response.

What Six Engineers Say

The replies proved interesting. One engineer pointed out that, "The idea of using a cabinet lining seems to have little merit. If the chamber resonance is below the range of the loud speaker, or does not correspond to a peak in the response, no treatment is needed. All a lining can do is to absorb say 50 per cent. of the harmful sound, which is necessarily loud so close to the loud speaker. The remaining 50 per cent. will do practically as much damage, if the condition is noticeable, as all of the original energy."

The chief engineer of a large receiver manufacturing company wrote us, "In the attempt to find a suitable lining material for the cabinet it has been our experience that differential absorption exists with practically all materials which have an absorption coefficient sufficiently high to

prevent coupling from the loud speaker to the tubes by the absorption of the energy caused by resonance in the cabinet. This means that the loud speaker response is partially altered due to the fact in some materials the higher frequencies are absorbed much more readily than the lower frequencies, causing non-linear energy response with respect to frequency."

From another engineer we learn, "We have done very little work along this line but the results to date indicate that lining of offending cavities with sound-absorbing materials is not very effective. We have found that venting the walls or floor of the cavity is a far better solution. A reduction of 3 db (50 per cent.) in energy at resonance, which is about as much as can be expected by lining cabinets with sound-absorbing materials, is barely noticeable and certainly is not a practical method of attack. I believe you will find that any information you may gather on this subject will be of considerable interest."

Another engineer says, "For small loud speaker cabinets, the use of absorbing material inside the cabinet is often advisable. For large size cabinets, I do not see any better way than leaving the back of the cabinet open."

From the chief engineer associated with a large radio receiver manufacturer we learn, "We have found that venting the walls or floor of the cavity is a far better solution than using sound-absorbing material. It frequently happens that a shelf or wall of the cabinet will vibrate and thus augment the hang-over due to cavity resonance. More rugged construction or breaking up of the vibrating surface by slits or holes is the customary remedy. We further find it very desirable to use a large opening in the cabinet for the loud speaker, the gap between the edge of the opening and the diaphragm of the loud speaker

being closed by a baffle of sound-proofing material such as Celotex.

Another engineer stated that "In my estimation, there are several kinds of cabinet resonance. The first and simplest is the natural frequency of the air chamber itself. It is always quite pronounced and usually very easy to eliminate by making suitable openings in the cabinet. The second and much more harmful resonance is that of the wooden structure which is not simple. On the contrary it is very complex and interlinked with acoustic regeneration. Some manufacturers suspend the chassis on rubber cushions.

Data From Insulite Co.

With these and other replies as a basis we then made contact with several companies and individuals who were more directly concerned with the properties and uses of acoustical materials. From V. L. Larson and J. M. Osborne, of the Insulite Company, we received the following summary:

"The differences between reverberation, resonance, and cabinet vibration effects produced by the loud speaker operating under heavy loads are not clearly understood.

"Cabinet resonance is, of course, perfectly normal and easily handled. Resonance usually occurs in well-made radio cabinets at the lower frequencies if at all. In light-weight veneer cabinets resonance effects are much more pronounced, due to the mass characteristics of the cabinet system.

"Large area panels, especially when constructed of veneer stock, will have acoustical characteristics. However, panel vibration is not resonance, and should not be confused with resonance effects. The solution of this type of trouble is obviously one of rigidity and the proper cutting up of the large areas, capable of relatively large displacement amplitudes, into small

FREQUENCY	128	256	512	1024	2048	4096
WATSON		.36	.70	.76	.76	
KNUDSEN	.37	.50	.67	.74	.80	.77
SABINE		.38	.61	.70	.57	.46
BU. STDS.	.19	.42	.61	.72	.76	
AVERAGE	.28	.42	.65	.73	.77	.77?

FREQUENCY	128	256	512	1024	2048	4096
WATSON		.24	.47	.49	.60	
KNUDSEN	.28	.32	.46	.56	.61	.62
SABINE		.27	.40	.46	.42	.42
BU. STDS.	.16	.26	.40	.62	.64	
AVERAGE	.22	.28	.43	.53	.62	.62?

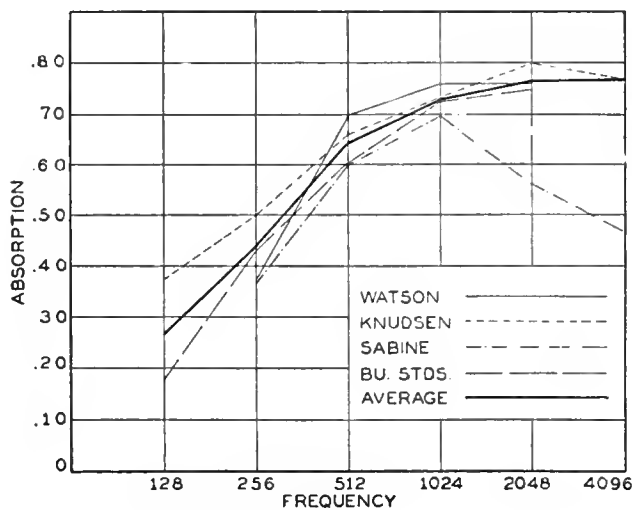

Celotex type B B

Fig. 1

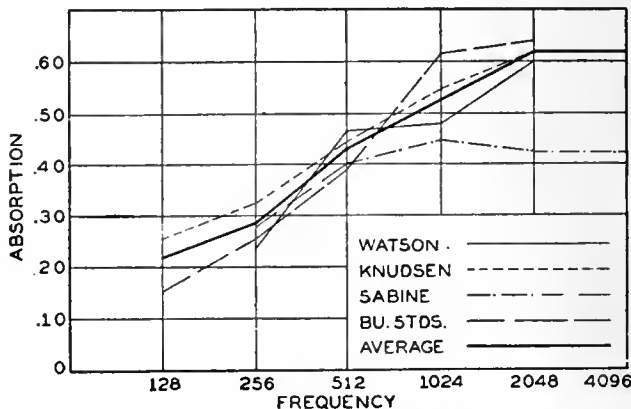

Fig. 2

Celotex type B



A Rayleigh disc having a period of vibration of 15 seconds was housed in the box shown above. The disc was 1.2 cm. in diameter, 34 mg. in weight, and was suspended by a quartz thread about 15 cm. long.



The two pictures above and the one below show views of the apparatus used by F. R. Watson, of the University of Illinois, in his tests on acoustic material. The results of this work appeared in bulletin No. 172 published by the University. Above is shown the reverberation room.



Courtesy Temple Corporation

The sound-proof room pictured above is lined with type B Celotex. The sound absorption coefficient of the material is 0.7 and the thickness of the lining is 8 inches.

areas having low amplitudes. The result of proper rigidity and support is the reduction of amplitude displacement to a value where this effect becomes negligible. That rigidity and support are important may be seen from the fact that the limits of panel amplitudes, or displacements, necessary to produce a barely audible and an intense sound range from 5×10^{-8} (0.00000005) to 0.004 inch.

“Reverberation is the chief cause of trouble in radio cabinets, especially those types having appreciable depth. The cubical content is the governing factor in any radio cabinet. Optimum reverberation is that time value giving best acoustical results and can, for example, be accurately calculated by formula. We are now working on a formula suitable for use with very small volumes such as are encountered in radio applications. For large volumes, such as rooms, auditoriums, and theaters the equation is

$$t = \frac{0.05V}{a}$$

where t is reverberation time in seconds; V is the room contents in cubic feet; and a is the number of acoustical units (absorption coefficient times area in square feet).

“Acoustical units are calculated using an open window as a basis of 1.00 unit per square foot. In this respect Insulite has a value of 0.30 at 512 d.v. (double vibrations), the absorption values decreasing slowly at lower frequencies and increasing slowly as the frequency increases.

Open Back Cabinets

“We wish to point out one fact that governs the use of open back cabinets, especially those of appreciable size. This is the fact that while the sound-absorbing constant of an open space is unity, this value assumes infinite space behind the opening. When a radio cabinet is placed in a room and is set out at a varying distance from the wall, the open space does not act as an efficient absorber but becomes, in reality, the mouth of the horn formed by the cabinet. The wall behind the cabinet, therefore, must assume the duty of absorber, and since the absorbing coefficients of walls are of very small magnitude, the sound issuing from the cabinet is reflected into the room and back into the

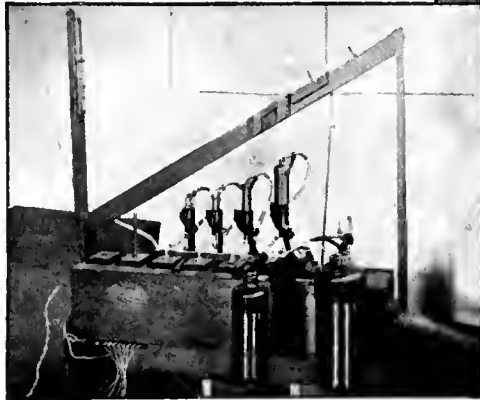

Watson's tone variators were adjustable Helmholtz resonators. They could be tuned easily and were practically free from overtones.

cabinet at practically the same intensity as when received.

“This reflection from wall to room results in greater efficiency since the input into the loud speaker may be much lower for a given sound intensity; it being assumed that no bad acoustical effects occur. Actually, however, the reflected wave and the wave emitted by the front of the loud speaker are not in synchronism; the result being a lack of clear cut articulation which may become very serious when the loud speaker is being operated at high sound levels. This reflection and secondary cabinet reverberation may be corrected in several ways; for example, by enclosing the back almost entirely but leaving a sufficient number of openings to equalize the air pressures within the cabinet. Large cabinets, having very bad reverberation and druminess effects, have been treated by a new method which cannot be disclosed at the moment so that the barrel effect was eliminated and clear cut audition obtained. Varying the adjustment beyond this point resulted in an ultimate total lack of quality, the entire system being so dead acoustically as to be lifeless and impractical. This method is, therefore, applicable to any size of cabinet and any type of loud speaker, since the practical results have proved that the optimum, or any other, degree of reverberation can be obtained for any such system. However,

it should always be kept in mind that a certain amount of reverberation is desirable in any enclosure in order that the esthetic aspect of pleasing, well rounded out tones be secured.”

There is one point in the preceding discussion about which a few more words might be said. The separation of cabinet resonance (vibration of the cabinet itself) and reverberation is desirable to clarify the discussion. It should be realized, however, that reverberation is actually resonance of the air activity.

Mr. Knudsen's Opinion

We asked V. O. Knudsen, of the University of California, well known for his work in sound, for his opinion on the subject and he answered with the following interesting comments:

“The resonant frequency of the average radio cabinet is very low. When used as a housing for an electrodynamic loud speaker which ordinarily is an efficient radiator of low-frequency sound, there is certainly a tendency to over-emphasize the low-frequency components. The loud speaker and cabinet may actually constitute a coupled system which would selectively enhance the low frequencies. Naturally, the lining of the cabinet with absorptive material will introduce resistance and loosen the coupling, both of which factors would tend to eliminate any sharp resonance. Since such resonance as may be developed by the cabinet has a low frequency, it is necessary to line the cabinet with material which has relatively high absorption at the low frequencies. This calls for a rather thick lining. For example, one half an inch of felt has a coefficient of sound-absorption of only about 0.08 at 128 d.v., which is not much more absorptive than wood which has a coefficient of about 0.06 at 128 d.v. Felt two inches

thick has a coefficient of about 0.20 at 128 d.v. This would be expected to reduce greatly the resonance at low frequencies, whereas a one-half inch thickness of felt may not be adequate.

"I have not conducted any research on

FREQUENCY	128	256	512	1024	2048	4096
WATSON		.12	30	48	55	
KNUDSEN	.19	.23	32	39	52	50
BU. STDS.	09	14	.22	.47	63	
AVERAGE	14	.16	28	.45	57	55?

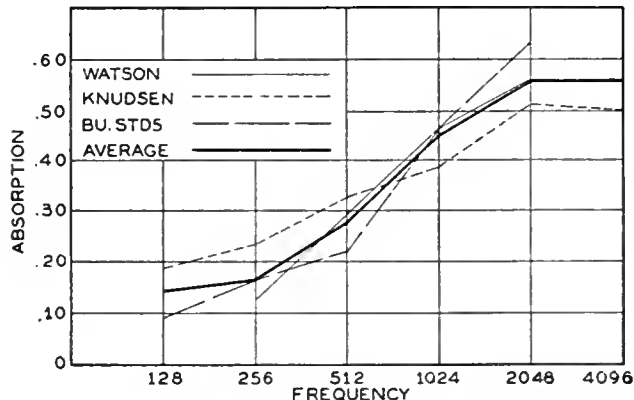

Fig. 3—Celotex Type C

this specific problem; but it seems to me that it is highly important that the subject be given a thorough investigation. It is certainly a subject which admits of both theoretical and experimental work, and it would seem to me that careful work of this nature would be handsomely rewarded. It is not improbable that a type of absorptive material could be developed which would supplement the loud speaker unit in such a way as to provide a more uniform radiation of energy at all frequencies in the sound spectrum. Certainly it does not seem feasible to use as a lining a thin felt which is probably five or six times more absorptive for high frequencies than it is for low frequencies."

Data from Celotex Co.

Wallace Waterfall, who has done considerable work for the Celotex Company, has given his opinion on the manner in which tests on this problem should be conducted. He says:

"The only way to answer the question is to make proper tests. When such experiments are made I believe that care must be exercised in setting them up in the proper way. The normal way of measuring the effect of absorption on resonance would probably be to place a loud speaker in some kind of a cabinet, actuate it with an oscillator, and determine the acoustic response both with and without an absorbent lining in the cabinet. This may be the wrong procedure. In actual practice the radio receiver is mounted in the same cabinet with the loud speaker and the vibration from the speaker is communicated to the receiver. At points of greatest cabinet resonance the vibration of the console is the greatest. This vibration is communicated to the tubes which, through microphonic action, still further amplify the resonance points. Celotex or Acousti-Celotex as cabinet lining should tend to reduce the loudness of the air sound at resonance, as well as to reduce the vibration. Therefore, I believe that a test should be set up on a standard radio set consisting of loud speaker, receiver and all. The source of sound used for the test purposes should be a radio-frequency oscillator modulated to the various test audio fre-

quencies. Such a test would be very difficult. It would require electromagnetic shielding as well as careful attention to the interference pattern in the room. It might be simplified somewhat by an investigation of the response near the resonance points only."

The effectiveness of any acoustic material in reducing so-called resonant effects is due not so much to its absorption characteristic at the particular frequencies at which excessive response occurs as it is due to a change in the resonant frequencies that an acoustic lining produces. Lining any enclosure with an acoustic material will generally lower the resonant frequency and in this way may lower it to a frequency below which the ear is sensitive so that even though the resonance does occur it is not objectionable. It would be hardly worth while to use some material with an absorption coefficient of say 0.5 if the only effect of the use of such material were to decrease the response at resonance by half. Actually, however, the use of a material with such an absorption coefficient might prove effective because of the change in the resonant frequency which it produces—the absorption coefficient of such

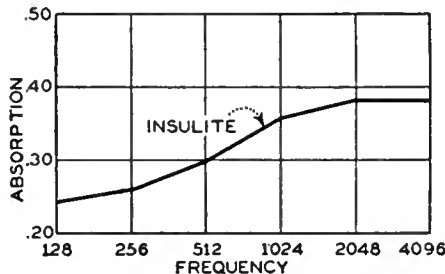

Fig. 4—Insulite Acoustile

material does not have to be 100 per cent. to render resonant effects negligible.

The data which must form the basis of any actual measurements are the absorption characteristics of the material to be used. In Fig. 4 are given such absorption characteristics for Insulite, a material made by The Insulite Company. In Figs. 1, 2, 3, and 5 are absorption characteristic curves of different types of Celotex made by the Celotex Company. All these curves were determined by the same method.

Whether the elimination of excessive response at low frequencies—the difficulty most generally met with in radio receiver design—will be by the use of cabinet lining is problematical. It is certainly true that the greater part of these effects has been eliminated by methods other than that of lining the cabinet. It is quite possible that the solution lies in the better design of the cabinet which houses the radio receiver and loud speaker. A loud speaker cabinet has three dimensions and therefore three natural periods of vibration, one corresponding to each dimension. Each of these

periods or all of them may cause considerable trouble depending upon where the resonance frequencies occur. Of course, the smaller the cabinet the higher will be resonant frequency, assuming that the material in both cases is the same. One engineer suggests the possibility of designing the cabinet so that there is no partition between the receiver itself and the loud speaker. This will effectively increase the area of the cabinet.

As Knudsen points out the disadvantage of some types of acoustic material as a cabinet lining is that it may have absorption characteristics that increase with frequency so there is a certain amount of differential absorption with respect to frequency, the greatest absorption usually occurring at the high frequencies—where it is not required. In fact, decreased response at the high frequency is found in altogether too many receivers, and it would hardly seem advisable to make use of a material that would tend to increase the high-frequency suppression. An engineer with whom we communicated pointed out that such an effect took place in some actual laboratory work which he conducted. The use of an absorbing material with a higher absorption coefficient at high frequencies than at low frequencies actually enhanced the low-frequency resonance due to the fact that the high frequencies were attenuated more than the low frequencies and as a result the low-frequency resonance stood out even more prominently. It seems likely, however, that such an effect would not be noticed except with a material having a relatively large ratio of high-frequency absorption to low-frequency absorption. As the curves given in this article indicate this is characteristic of some, but not all materials—for example Fig. 5 gives the characteristic of a special Celotex board which has essentially uniform absorption over the range indicated, and, assuming that the curve continues at the same slope, the absorption at 4096 d.v. will be about 0.35 or only 1.7 times the absorption at 128 cycles. If material of such characteristics were to be used, it should not produce excessive absorption of the high frequencies relative to the lows and might prove very effective in eliminating resonance by lowering the frequency at which such effects take place. In actual practice the two factors of cabinet vibration and reverberation are tied closely together and the use of acoustic lining should lower the frequency at which either effects take place.

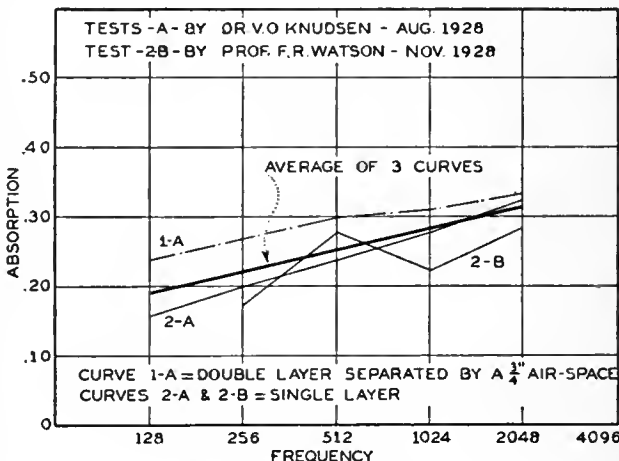
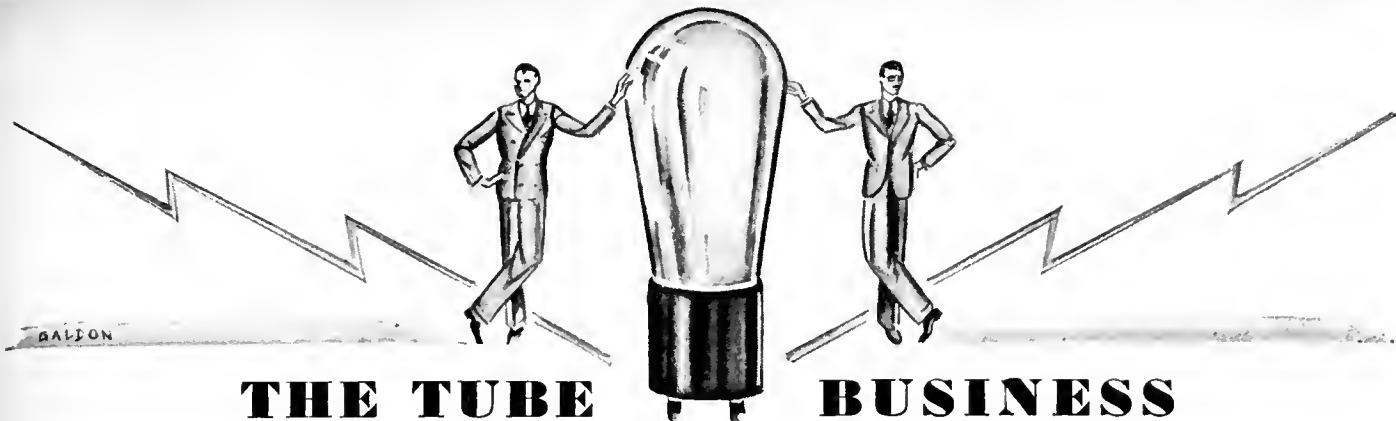

Fig. 5—Special Celotex

The final decision of whether or not the use of such materials has any place in radio receiver design is something that can only be answered by actual measurement. The final answer must come out of the laboratory.



THE TUBE BUSINESS

FINANCIAL AND PRODUCTION NOTES

CeCo—Assets on Oct. 15, \$2,500,000. Same date 1924, assets \$24,000. Sales ten months ending October 31, \$2,168,902. Same period 1928, sales \$877,681. Earnings per share twelve months ending September 30, \$6.37.

PERRYMAN—Sales September \$176,602, October \$230,000. Sales October, 1928, \$126,000. Production in October, 15,000 per day. Production of screen-grid tubes in October, 5000 per day.

DEFORREST—Net profits six months ending September 30, \$261,109. Estimated profits third quarter 1929, \$900,000 to \$1,000,000.

Note: These data are taken from various sources, which we believe to be reliable, but the Editors cannot be responsible if errors occur. Unfortunately errors sometimes do occur. The most recent occurrence did an injustice to the CeCo Manufacturing Company. We are informed by Ernest Kauer, of CeCo, that at the end of July, 1929, business showed a 202 per cent. increase over the same period in 1928.

DEFORREST GETS LARGE CONTRACT

THE DEFORREST RADIO COMPANY has closed a contract with McKesson and Robbins, Inc., who control 17,000 retail drug stores in the United States, to sell DeForest tubes exclusively. An initial shipment of 100,000 tubes was made in October.

IMMUNITY TO SURGES

ONE OF ARCTURUS' talking points is "immunity to line surge." Not long ago a Fada receiver in Newark, N. J., was struck by lightning. Five tubes were Arcturus; three were not. After the fire department, etc., had done its work, it was found that the five Arcturus tubes were o.k. The others were burned out. Arcturus engineers feel that such a filament will take care of any normal line voltage surge.

EXCLUSIVE TUBE JOBBERS

ACCORDING TO Edward T. Maharin, CeCo, the volume of tube business is near the point where distributors will be justified in concentrating their entire efforts on this single item of radio merchandise. The volume of tube business approaches that done in complete sets, and, since there is no obsolescence in tubes, it begins to look as though a distributor could afford to handle no other item.

The Serviceman's Job

By F. D. WILLIAMS
Radio Tube Division, National Carbon Company



F. D. Williams

Mr. Clerk, Mr. Salesman, a window display, the printed page—these are usually the first contacts between a radio manufacturer and a consumer. Once the sale is made and the receiving equipment has been initially installed all these contacts are broken and it is you, Mr. Serviceman,

who carries on for us.

It is you who answers the distress signal, S. O. S. (service on sets or supplies), and the good will of our customer depends a great deal on your ability and conscientiousness. You have it in your power to help or hinder the progress of a manufacturer of sets or tubes.

You are in a position, when in the normal course of events a reliable make of tube needs replacing, to put in another tube of comparable value, and when you find a case in which a good set is handicapped by a poor make of tube you can be of real service to your client and to the reputable manufacturer by advising a change to the right brand of tubes.

Ever since our "BH" gaseous rectifying tube was developed we have found you rendering us loyal, intelligent support, and following the introduction of the complete Eveready Raytheon Radio Tube line reports from all sources indicate that you are again giving us the same consistent, valuable cooperation.



Ben Erskine, president, Sylvania Products Company, is often seen in the laboratory checking with his engineers.

NEW DE FOREST TUBES

THE DEFORREST RADIO COMPANY, of Jersey City, N. J., announces a comprehensive line of transmitting tubes as follows:

Type	Description	Price	\$	9.00
510	15-watt Oscillator			
503A	50-watt Oscillator			40.00
511	50-watt Modulator			40.00
545	50-watt Amplifier			40.00
500	500-watt Oscillator			130.00
520B	5-kilowatt water-cooled tube			250.00

Other transmitting tubes are being placed in production, such as higher-power oscillators and mercury rectifiers, as well as various sizes of screen-grid, and general-purpose tubes.

The DeForest transmitting tubes are sold by the factory to consumer direct, and at the above net prices.

A NEW WORLD'S RECORD

THE SYLVANIA PRODUCTS COMPANY, are claiming a world's record for two Buffalo salesmen. O. J. Loersch, of the Buffalo Talking Machine Company, and Walter Dossert, of the Philco Buffalo Distributing Company, are the two men. They teamed together for a five-week drive and between them they sold 14,637 Sylvania tubes. "This," says Fred Strayer, the Sylvania sales manager, "we claim as a new two-man world's record, and we will consider it so until proof is furnished that will testify that the new world's record has been broken."

TWO INTERESTING QUOTATIONS

A quotation from the service department of one of the largest producers of radio receivers in the United States: "We know that the majority of service is caused by tubes and other accessories."

Quoting again from a set manufacturer, this time from the sales manual, "There are a number of fast-heating equipotential cathode tubes on the market to-day, including both the '27 and '24 types. Under no circumstances should any of these tubes be used in any of our receivers, since they are extremely noisy. The quick-heating type has insulating washers of white material at either end of the cathode, and the heater return (which is outside the tube elements since the heater itself is a spiral within the cathode) is covered with a glass tube between the mica support and the glass stem. A great deal of the hum in this tube is due to the magnetic fields from the multi-turn coil of the spiral heater and from the large single turn formed by the heater and its return."

WHAT HAPPENED IN RADIO MERCHANDISING IN 1929

(Continued from page 130)

or on the top shelf of a closet, a loud speaker for wall mounting in foyer, stair landing, or hall, at enough distance from the dining room and living room so that music filters into them gently and pleasantly. By elimination of expensive cabinets, this remote control outfit will not be much more expensive than present-day receivers, although the dealer will have an opportunity to earn a good installation profit. That kind of remote control would greatly increase the average listening hours and would mean, in turn, larger tube sales.

Condenser loud speakers have not swept the market. Manufacturers are marking time to determine their life and performance qualities. If remote control ultimately eliminates the cabinet, decorative wall-type condenser loud speakers may become a possibility.

Tube Sales: An outstanding merchandising trend is the greatly increased proportion of tube sales to total sales. The cumulative effect of tube sales is helping materially to stabilize dealer turn-over. But the position of the average dealer has not improved greatly during the year because of the excessive number of radio outlets. The possibility of more active competition by automotive distribution channels as a result of the new Radio-General Motors alliance is causing some apprehension. The automobile salesman is trained to aggressive personal salesmanship. He may replace the type of radio dealer who does not begin to work on a prospect until he comes into the store to buy.

Too Many Outlets: The statistics distributed by the Department of Commerce through the cooperation of the National Electrical Manufacturers Association prove conclusively that the industry is suffering from a large proportion of inefficient outlets. One-third of the 39,153 outlets did a business of less than \$500 during the quarter ending July 1, 1929, the latest date for which detailed figures are available. On the other hand, dealers selling more than \$100,000 in that quarter, constituting less than 0.2 per cent. of the

total number, did 13.95 per cent. of the total business reported. More conclusive is the fact that the mere 4.22 per cent. of the dealers who did more than \$10,000 during that quarter accounted for 51.16 per cent. of the gross business. Obviously, a distribution system which does about half its business through one twentieth of its outlets is heavily laden with dead wood. Instead of improvement in the situation, however, the number of outlets increased by 20 per cent. during the year.

If radio sales fail to show marked gain, we may look to a substantial reduction of outlets, with the consequent disappearance of many lesser manufacturers depending upon them. This would be a desirable trend because the industry is burdened with altogether too many minor manufacturers. Most of them will take the merger route to oblivion. With one or two exceptions, all mergers to date have been of that character.

Chain Distribution: The trend toward chain distribution, which is progressing so markedly in other fields, has made slow but steady progress in the radio industry. The outstanding event of this character was the consolidation of the Atlas, Davega, Fanmill, City Radio, and Abe Cohen Exchange, forming a combination of 61 stores in New York, Newark, Chicago, Detroit, Cleveland, Cincinnati, and Akron. Chain distribution, however, requires high turnover, a condition obtaining in the radio field only in relatively few large broadcasting centers. In consequence, extension of chain distribution to radio's greatest unsold market, the rural districts, is not an immediate prospect.

Concentration of the industry's sales activities in urban centers is indicated by the continued decrease in percentage ratio of battery to a.c. receivers sold. The available figures are as follows:

Quarter Ending	Per cent. d.c.	Per cent. a.c.
July 1, 1929	6.3	93.2
April 1, 1929	10.0	90.0
January 1, 1929	10.1	89.6
October 1, 1928	19.3	80.8

The rural market is yet untapped. No manufacturer of standing is concentrating

upon the production of battery receivers of real capability giving results comparable to those secured with a.c. sets.

Television: If only for sentimental reasons, we mention television which, last year at this time, was arousing considerable attention. The public interest in television of a year and two years ago was the product of excessive premature publicity and the expression of an unfulfilled desire. But no longer is the public startled by announcements of magnificent achievements in television because such announcements have too often been unadulterated hokum. The public's idea of what constitutes television of entertainment value is based upon home motion pictures as a criterion. Home movies are so far ahead of the most magnificent television device which has been demonstrated that the available crudities can hardly be classed as commercial possibilities. The trade awaits with enthusiasm the appearance of a really commercial and salable television device because it knows the public to be ready to buy it. Laboratories and scientists are bending efforts toward the production of such a machine but they have still a long way to go. We are awaiting a fundamental development to make possible at least 100-line television of considerable reliability. Anything less than that has insufficient entertainment value to have public appeal and must be classed as an experimental device or a curiosity.

Conclusions: The year 1929 has been successful as far as volume is concerned, but the industry has failed to make much progress toward the inevitable adjustments which it faces; namely a radical reduction in the number of manufacturers and the elimination of inefficient outlets. The industry has yet to face a year of reduced consumer spending to demonstrate how small is its margin of selling power over production. One such year would have a salutary effect in eliminating weak units and in developing the industry's sales ability. We are still a long way from a set for every American family but are reaching the day when the industry must sell the individual prospect rather than wait for him to come and buy.

WHAT HAPPENED IN RADIO ENGINEERING IN 1929

(Continued from page 131)

local-distance switch provides a total control of about 10,000 to 1, which is sufficient for present conditions.

Remote control got a late start in 1929 and will come into much greater prominence in 1930. The ideal seems to be a device which gives the user perfect dial control over the receiver as distinguished from that type which permits reception of a number of stations by pushing various buttons.

The year saw few fundamental circuit changes. Uniform sensitivity was one of the biggest advances. So little of a quantitative nature on band-pass circuits has been published that it is difficult to state the extent to which these circuits, from which much has been expected, have been advanced. Another advance will be uniform selectivity. Perhaps the year 1930 will see it.

The year saw almost complete acceptance of the moving-coil electrodynamic loud speaker. Whether the balance in favor of these loud speakers as against the magnetic, the inductor dynamic, or the condenser type will be maintained de-

pends upon engineering development. If someone develops a more sensitive, less costly, lighter, and longer lived loud speaker, manufacturers will be quick to accept it. It is strange how little has been the general acceptance of the inductor speaker. It is sensitive, has a good characteristic, requires no field power, has a fairly high overload limit, and is inexpensive.

The fidelity characteristic of console receivers has been improved somewhat. The boomy effect has largely disappeared. There is still a dearth of high audio frequencies, but some manufacturers deliberately cut them out by means of filters for the benefit of users far from local stations who want as little static and other noise and as much program as possible. Some manufacturers have adjustable fidelity so the listener can have more or less high or low tones as he pleases. In some this is continuously adjustable; in others a switch throws in a certain definite loss at either end of the musical scale.

The fidelity obtained from phonograph pick-up units has improved, but, because of mechanical and electrical limitations, it is not up to par with the best broad-

casting. This deficiency is divided between record and pick-up. Electrodynamic loud speakers have improved both in frequency response and efficiency.

Many 100 per cent. modulation transmitters have gone into service during the year with consequent better service. Many manufacturers have engineered their receivers with the object in view of decreasing the possible mechanical or electrical trouble in service; many of them have improved the mechanical arrangement of parts so that the serviceman has less difficulty in getting at the trouble and fixing it. Unsightly antennas, some thousands in number, came down during the year as a result of two developments: one, the use in apartment houses of a single, high, well-insulated antenna connected by transmission lines to each listener who gets the impulses traversing this conductor but without annoying his neighbor by stealing the signal or sending out one of his own; the other cause for an early demise of overhead wires is the superior sensitivity of some receivers. A 100-foot antenna is no longer necessary; instead, the ice pick will do.

SM

“S-M 722 a Knockout” —Setbuilders Demand D.C. Design—It’s Here!

The Record-Breaking S-M 722

Experienced setbuilders have learned to expect big results from any screen-grid custom design that S-M offers—but the 722 Band-Selector Seven has broken all records. And no wonder—a custom receiver that is sold, completely wired, at \$74.75 net, topping the performance of widely advertised factory sets selling at twice the price. Yet there is nothing mysterious about it—just the long experience of S-M engineers applied to the job of producing those essential receiver parts whose quality spells the difference between the performance that “gets by” and the performance that an S-M fan demands. Everything that is the “last word” is in the S-M 722—the '24 power detector, the band filter—the uniform gain all over the dial—single dial tuning—all-electric with built-in power supply. Tubes required: 3—'24, 1—'27, 2—'45, 1—'80. Wired, less tubes, \$74.75 net; parts total \$52.90.

The new 722DC for battery use gives every advantage of the a. c. design—big volume, DX ability, and uniform amplification at all frequencies, just like the a. c. set—truly the ideal battery receiver. Tubes required: 3—'22, 3—'12A. Similar in appearance to 722 illustrated. Wired, less tubes, \$57.50. Parts total \$38.50.

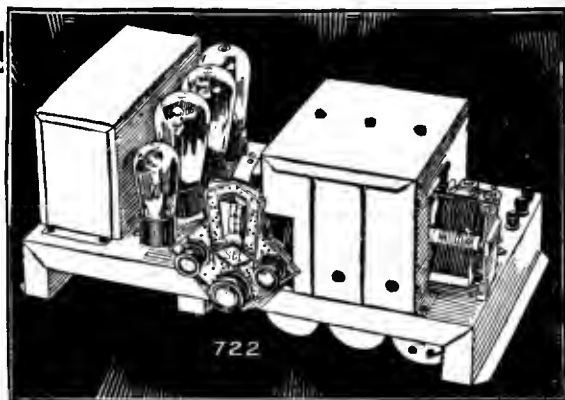

Do You Want Absolutely the Best There Is?

It doesn't cost an awful lot more than the 722, but this S-M 712 tuner, in its neat innocent-looking all-metal shielding cabinet, is absolutely guaranteed to out-distance and out-perform all competition regardless of circuit or price—just as its famous predecessor, the Sargent-Rayment 710, did last year. Read, in last month's issue of this magazine, how one listener living only a mile from the powerful WSM tunes in regularly a station 400 miles away with only 20 kc. separation! That's performance—and with one-dial tuning—no verniers. Tubes required: 3—'24, 1—'27. Wired as shown, less tubes, \$64.90 net. Parts total \$40.90.

Any good audio amplifier can be used with the 712; ideal tone quality and perfect convenience are secured by using the S-M 677. Uses 1—'27, 2—'45, 1—'80 tubes. Wired complete, less tubes, \$58.50. Parts total \$43.40. For 25-40-cycle current, \$72.50 wired.



And a “Bearcat” for the Short Waves

“The little 735 is a “bearcat”. The way it will pick up stations is nobody's business. You want to see the hams come in and play with it. First one I wired I got 5SW Chelmsford, England, also a Dutch station and a lot of others . . . this was around 2 P. M.”

That's the verdict of R. G. Sceli of Hartford, Conn.—one of the most expert setbuilders in New England, and remember he is speaking of the first completely-a.c.-operated short-wave sets ever brought out! The new S-M 735 Round-the-world seven is carrying all before it this year. On same chassis as the 722; tubes required: 1—'24, 2—'27, 2—'45, 1—'80; wired \$64.90, parts total \$44.90. 735DC for battery use, using 1—'22, 4—'12A, wired \$44.80. Parts total \$26.80.

A full line of cabinets is available for all these S-M receivers—the beautiful 707 table cabinet, in rich crystalline brown and gold,

is only \$7.75 net. The cabinets of remarkable charm are listed in the S-M catalog—see coupon.

“THE RADIOBUILDER” for December contained details of the 722DC; every issue gives advance technical information of great interest and profit to setbuilders. Use the coupon!

Over 3000 Authorized S-M Service Stations cover the United States and Canada. Many are profiting handsomely! Write us for the address of the nearest one if you wish a custom-built set. Setbuilders write us regarding a franchise in your territory.

SILVER-MARSHALL, Inc.

6403 West 65th Street
Chicago, U. S. A.

Silver-Marshall, Inc.
6403 West 65th Street, Chicago, U. S. A.

..... Please send me, free, the new fall S-M Catalog; also sample copy of the Radiobuilder.

For enclosed.....in stamps, send me the following:

..... 50c Next 12 issues of The Radiobuilder

..... \$1.00 Next 25 issues of The Radiobuilder

S-M DATA SHEETS as follows, at 2c each:

- No. 3. 730, 731, 732 Short-Wave Sets
- No. 4. 255, 256, etc., Audio Transformers
- No. 5. 720 Screen Grid Six Receiver
- No. 6. 740 "Coast-to-Coast" Screen Grid Four
- No. 7. 675ABC High-Voltage Power Supply
- No. 8. 710 Sargent-Rayment Seven
- No. 9. 678PD Phonograph-Radio Amplifier
- No. 12. 669 Power Unit
- No. 14. 722 Band-Selector Seven
- No. 15. 735 Round-the-World Six
- No. 16. 712 Tuner (Development from the Sargent-Rayment)
- No. 17. 677 Power Amplifier for use with 712
- No. 18. 722 DC Band-Selector

Name.....

Address.....



THE SERVICEMAN'S CORNER

A Symposium on Noise

NOISE continues to be a major service problem. Under the category of noise may rightfully be included motorboating, intermittent reception, hum, frying, and noise in general. The following servicemen have contributed the data on noise printed below:

PAUL WALLER, the Boren Biegele Company, Little Rock, Ark.
 GEORGE GILLETT, Bismark, N. D.
 A. C. HOAG, West Allis, Wis.
 CHARLES W. FOSTER, Rochester, N. Y.
 HERBERT A. FISKE, Wareham, Mass.
 R. F. SNYDER, Lakemore, Ohio.
 J. E. BAINES, Kansas Power and Light Company, Topeka, Kans.

INTERMITTENT RECEPTION

In many cases it has been found that intermittent reception can be traced to tube trouble, as is indicated by the three instances which follow:

"One evening I was called upon to find the trouble in an electric set. When the set was first turned on and tuned to a local station it worked beautifully and with good volume for a short time, then the volume gradually diminished, and after a time began to pick up. While checking the tubes when the set was operating normally, I noticed that all the filaments were lit. Later when it was operating below normal I noticed that the heater of the detector tube was not lit, but the set would still work at reduced volume.

"The heater of this particular 6Y-227 was evidently cracked and when cold made perfect contact. However, when heated the metal expanded enough to open the heater and shut off the heating current in that tube. The set continued operating at low volume due to the fact that the heater was sufficiently warm to continue to operate until it had cooled down to a point where it made contact again.

WATCH FOR FLASHERS

"With the new 1930 receivers coming out on the market with either the 221- or 227-type tubes throughout, my advice to all my brother servicemen is to watch for flashers (the one that has the bright light on the top of the heater) and the oxygen generators which are indicated by the purple glow during operation. It has been found fading, buzzing, and intermittent noises are caused by these tubes. However, in some cases these tubes do not indicate the trouble until the receiver has been in operation for some time."

"An owner called and said his set kept going on and off. Sometimes it would operate for two or three minutes and then stop; then a slight jar would start it again. All indications suggested a loose connection, and so it was, but not where you would expect it. After all tests showed nothing wrong, the rectifier tube was examined and a cold soldered lead to the filament prong was discovered. It was just barely loose but the vibration of the loud speaker would jar it so it did not make connection. It was soldered again and there has been no more trouble."



The service laboratories of Clarke Laboratories, Danville, Va.

Mechanical imperfections are also at the bottom of numerous freaks of the intermittent type. "I recently ran into a trouble similar to the one mentioned by Mr. Glose in January, 1929, RADIO BROADCAST, but from a different cause," writes another serviceman.

ZENITH MODEL 14

"A Zenith Model 14 with a 4-gang condenser gave weak signals at times with the volume control turned on full. Sometimes a jar on the set or the floor would make it oscillate till the volume control was turned back, and then it would operate satisfactorily for an indefinite period of time.

"Indications pointed to something loose but the set tester failed to show anything. Taking out the chassis and attempting to adjust the little trimming plates did not do much good and the trouble came and went making it hard to find. Grasping the condensers and attempting to move them back and forth showed that one was apparently a little loose on the shaft, judging solely by the effect on the signal strength.

"The shaft of the condenser was iron and the castings which were of aluminium were held together by one taper pin in each unit. Drilling and tapping a 6-32 screw hole in the shaft at each unit, fastening with a flat-head screw, and then

putting in some longer taper-pins (so they could be removed more easily, in case of further trouble) has cured this case.

"I was called out to service one of the Stewart Warner 950 series a couple of nights ago. The set would play along and seemingly from no cause at all would cut out. A little jar would start it playing again. By shaking the first a.f. tube, which is resistance coupled, the set would act in the same way. I removed the bottom plate of the set expecting to find a loose socket spring or dirty tube prong. After cleaning contacts, etc., the set continued to act in the same manner. I found by shaking the by-pass condenser in the resistance-coupled stage it would play in one position or stop in the other. The solder lug is held in place by one brad. One lug of the condenser is soldered direct on the socket springs to hold it rigid with the result that the condenser, if pushed too far to one side, breaks loose from the tinfoil.

"This same trouble was found with the condenser bypassing the r.f. of the screen grids with the result that the set would oscillate over the whole dial range."

HIGH-PITCHED HUM

"It seems to me all the radio servicemen pick on center-tapped resistors or the shielding of the detector tube or something of the like to stop hum in a.c. receivers. I have found quite a bit of the above myself. In some cases, however, I have had to look elsewhere for the said hum.

"A Kolster developed a high-pitched hum which was stopped when a 1-mfd. condenser was connected from detector plate supply to ground. A bad hum in a Stewart Warner was also stopped by connecting a 2-mfd. condenser from the first a.f. supply wire to the ground. So I believe in capacity sometimes." (A Mershon condenser will often do the trick where every-thing else fails. Editor.)

MISCELLANEOUS NOISES

The noisy grid leak: "The resistor manufacturers did their best for some years to blame all noise on the grid leaks made by
 (Continued on page 166)

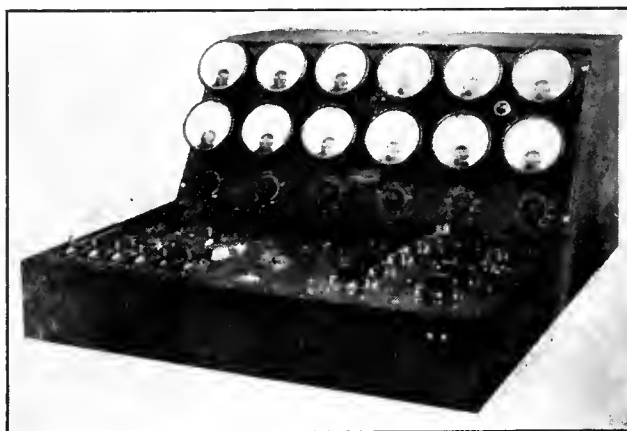

This elaborate tube-tester was designed by Westinghouse. It is intended especially for manufacturers' use.

Now D-C Tubes

by **ARCTURUS**

AND 2 NEW A-C TUBES GIVING
ARCTURUS DEALERS A COM-
PLETE LINE OF TUBES
FOR EVERY SET



PROVED PERFORMANCE
Demonstrate Arcturus' quick action, clear
tone and long life... there will be no question
which tube your customers will buy.

There's an Arcturus Radio
Tube for Every Popular Set.

127	180
124	181
126	012-A
145	101-A
150	099
071	071-A
	122

YOU know what the name Arcturus means on an A-C tube. Quick action, clear tone, long life. This kind of service has made Arcturus Tubes famous throughout the radio industry... a symbol of dependable tube performance wherever A-C sets are made, used or sold... Now we offer Arcturus *Direct Current* tubes, built to the same high standards that made possible Arcturus' A-C superiority. In addition, 2 *new* A-C tubes have been added to the Arcturus line, giving dealers complete Arcturus equipment for any popular radio set... Thousands of Arcturus dealers know that Arcturus A-C quality has helped them increase their set and tube sales. Now, with a complete line of Arcturus Tubes for D-C and A-C sets, Arcturus offers better profit possibilities than ever before. Your business, too, can benefit by Arcturus' *proved performance*. Stock and sell the entire Arcturus line.



ARCTURUS RADIO TUBE COMPANY
Newark, New Jersey

ARCTURUS

LONG LIFE
RADIO TUBES

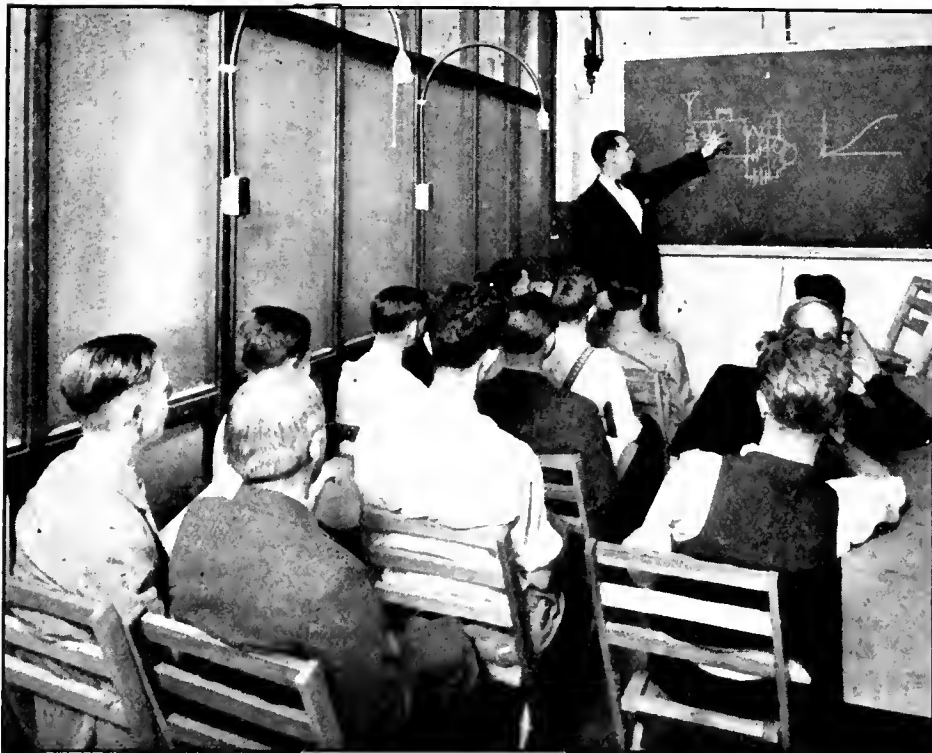

Robert Mac Gregor, Assn't chief engineer, Temple Corporation, conducts a service school for Temple Dealers.

(Continued from page 164)

their competitors. But the noisy grid leak is not altogether ballyhoo. It is wise to look to grid leaks in noisy sets. An a.c. Marshall S. G. Six kept giving a frying noise like fish in a pan. At first it was thought it was interference from some outside source, but when the antenna was disconnected it kept right on frying. After some time spent, a new grid leak was put in and the noise stopped."

The ground wire offends: "The other day I was called out to cure interference on an expensive set. It had a roar or buzz that would start as a low-pitched roar, get very loud, and then die away. This set like many others had by-pass condensers across the 110-volt side of the power pack and when the ground wire was disconnected a faint spark could be seen. This gave me an idea. Inspection of the ground connection showed that it had been soldered to an outside water pipe and the man that did the job forgot to drain the pipe. Also he used some kind of acid flux solder. The result was this: when the job was new everything was satisfactory but when the weather got in its work the corrosion set in, and crept under this cold solder job, causing a poor contact that would arc or spark as the contact changed from poor to may be none at all."

"A customer kept complaining of noise in the form of a put, put, put, of varying frequency and between wide time intervals. The set was a Radiola 62. Some time was spent waiting for the noise to start, which the customer insisted it would, in a few minutes. Sure enough it did, and it was, as he said, very annoying. I listened for several minutes. Again and again, the noise would start at low frequency and amplitude and increase in both and then die out. A bus 'stop' was right in front of the house, and it was soon found that the put, put, was the exhaust noise of a departing bus!

"A window strip lead-in, was broken in the center, and when it was replaced by a new one the trouble was ended."

MOTORBOATING

Rather unintentionally your editor has recently run into several very balling cases of motorboating, both in the labo-

ratory, and, in his own home! Without going into the theory of the thing, the possible cures are about four in number.

The mechanical arrangement in a homemade receiver may be responsible for motorboating. However, it is often difficult or expensive to change this, so all cases of motorboating may be considered on the basis of a commercial job.

It is seldom that motorboating will be encountered if the B and C potentials are correct. These should, therefore, be checked immediately. A variable by-passed resistor in the plate circuit (try in the order of, first a.f., detector, and middle r.f.) will often stop the trouble by virtue of one or both of two possibilities, i.e., establishing the correct B and C potential balance, and by reducing the plate voltage on an ionizing tube.

Ionizing tubes are almost a concomitant characteristic of motorboating—often in the power stage. Drop the voltage, with a by-passed resistor until the blue haze disappears or the motorboating ceases.

A bypassed a.f. choke coil, such as the primary of an amplifying transformer, in

the plate circuit of the detector or first a.f. stage will also often help matters.

The main point, in our own experience (which has been considerable as far as motorboating goes), is to watch out for ionizing tubes—tubes showing more than the slightest tinge of a blue haze.

An Output Meter

The serviceman's labors involve the pepping up of receivers that have lost selectivity and sensitivity due to loss of tuning alignment, and neutralization. These adjustments can be effected most rapidly and accurately with the aid of the vacuum-tube voltmeter—an inexpensive design of which is described below by S. S. TRUER, of the Chicago Radio Service Laboratory.

"We have found occasion to require an output meter for general use around the laboratory, being of great utility for neutralizing receivers, aligning gang condensers, checking overall gain and total output of receivers, where an accuracy greater than the usual headphone signal strength is desirable. Having investigated the market we found the cost of a suitable thermo-voltmeter far above the value of the instrument to us. Accordingly, the following apparatus was assembled and is now an indispensable article in our equipment.

"A simple vacuum-tube voltmeter was constructed using the conventional circuit, a 199-type tube, 0-1-mA. meter, and an a.f. transformer to supply the coupling between the receiver output terminals and the input (grid and filament) of the vacuum-tube voltmeter. The

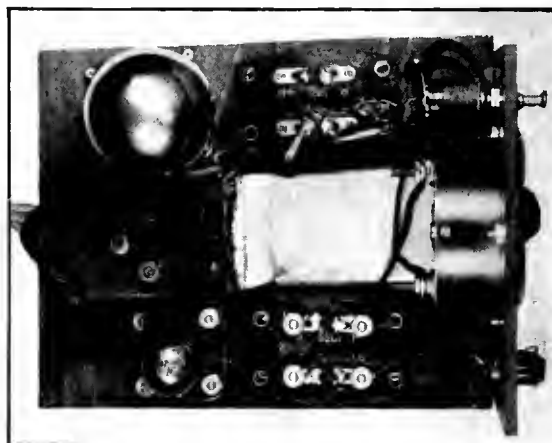

Baseboard view of output meter.

unit was constructed so as to be a.c. operated with the exception of the tube filament which was heated by means of a 1½-volt C battery. To supply the necessary plate voltage to the tube, another socket and tube was arranged as a B-supply unit. An old a.f. transformer having a burned out primary made a satisfactory choke, the secondary winding being used. The filter condensers were originally a 4-mfd. Dubilier 600-v. unit, which, having broken down, was opened and separated into four 1-mfd. sec-

(Continued on page 167)



The servicemen of the Sun Radio Company, Akron, Ohio, are dressed as shown above. The uniform identifies them as legitimate representatives of the company employing them.

(Continued from page 166)

tions. Each unit was tested, and the defective section discarded.

"The circuit diagram is indicated in Fig. 1, while pictures on this page suggest the constructional points.

"In using the meter the output or loud speaker terminals of the receiver under test are connected to the two input posts of the meter and the receiver is turned on.

"For alignment of condensers, neutralization, or overall measurements, as described in L. M. Hull's article appearing in February, 1929, RADIO BROADCAST, an oscillator of some type, such as de-



Front view of output meter.

scribed by G. F. Lampkin in July, 1928, RADIO BROADCAST, is used to generate a constant modulated r.f. signal and the receiver is tuned to resonance. As the receiver approaches resonance, the meter will show deflection, maximum deflection being reached when the receiver is in exact resonance with the received signal. The condensers are then adjusted by means of the trimmers, where a gang condenser is used in the receiver, until the highest reading obtainable is reached on the meter. It is advisable to align the condensers first on a comparatively high frequency, say 1300 or 1400 kc. working back and forth over the trimmers until a maximum deflection is reached, then setting the oscillator for a lower frequency of 550 or 660 kc., retuning the receiver to this frequency, and again touching up the

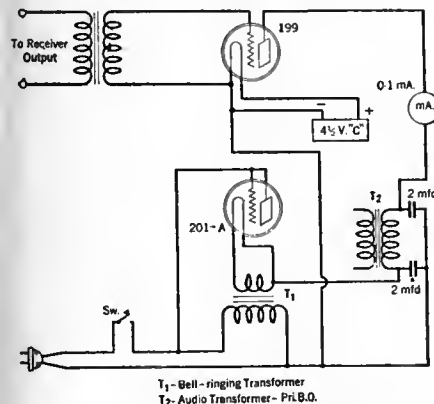

Fig. 1—Diagram of output meter with its simple B supply.

adjustments. In this way it may be discovered that the receiver does not give as great a deflection at one end of the dial as it does at the other, showing a lower over-all efficiency at a certain frequency. This may be due to poor design or assembly of the gang condenser and may be rectified by bending the plates of the rotor
(Continued on page 169)



Licensed under patents of the Radio Corporation of America and associated companies for radio, amateur, experimental and broadcast reception.

FULL VOLUME

OR THE MEREST WHISPER
With no distortion along the entire range

The Amertran Push-Pull Amplifier, Type 2-AP, is designed for radio listeners who truly appreciate fine music and its reproduction exactly as broadcast. With efficient loud speakers it will furnish ample volume for dancing in a large hall and agreeable rendition in a moderate sized auditorium. Or you can tune down a musical program to a faint, melodious background for an evening by the fireside.

There is no distortion at any volume. The shrill, bird-like treble of the flute has the same rich quality as the somber bass of organ or cello.

The Type 2-AP is a high quality two-stage transformer coupled audio amplifier with a push-pull power stage. It is designed for A. C. operation with a—27 A.C. tube in the first stage followed by standard power tubes in the push-pull stage, and is intended to be connected to the detector of any good receiver and operated from an A. C. power supply system, such as the Amertran Power Box, Type 21-D.

For complete information on the Type 2-AP Amplifier, write for Bulletin 1075-A.

AMERICAN TRANSFORMER COMPANY
172 Emmet Street, Newark, N. J.

AMERTRAN

Quality Radio Products

R B. 1-30

AMERICAN TRANSFORMER CO., 172 Emmet St., Newark, N. J.
Gentlemen:

Please send me Bulletin 1075-A containing complete information on Type 2-AP Amplifier.

Name

Street

Town

State

APEX MODEL 36

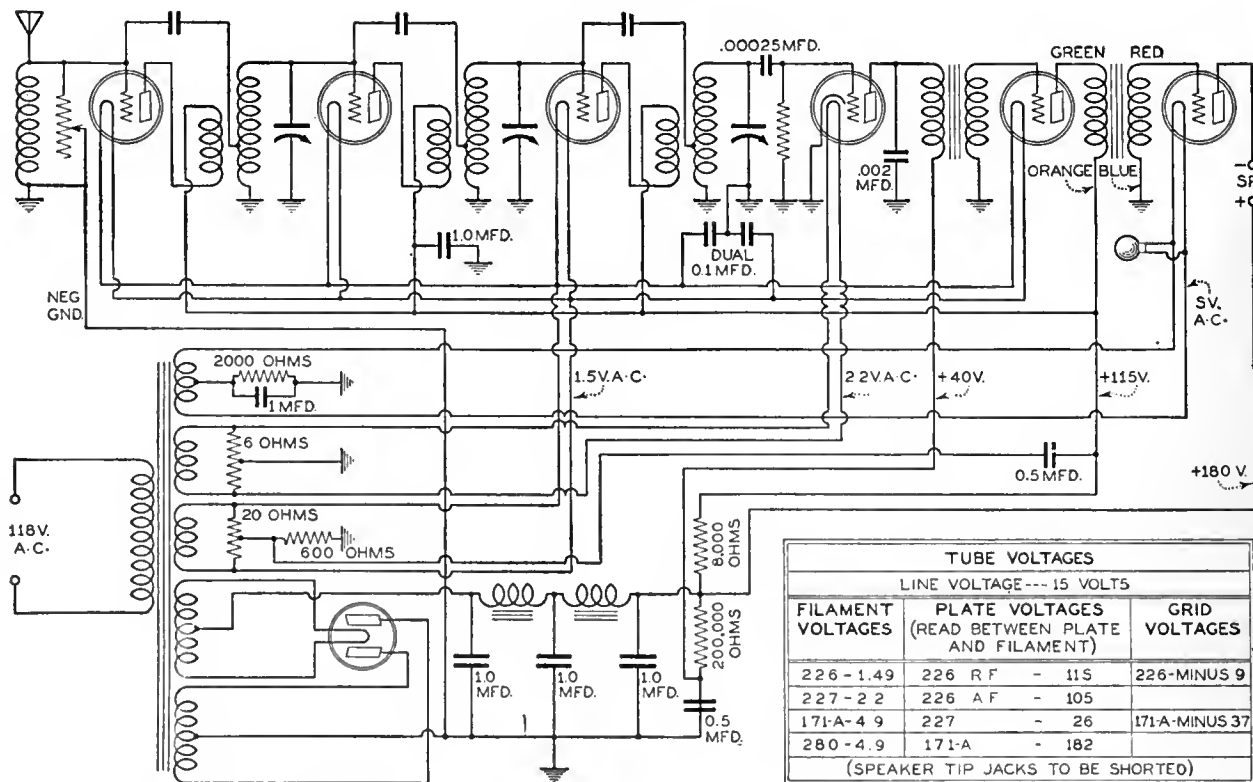

This is a six-tube a.c.-operated receiver consisting of three stages of tuned-radio-frequency amplification, a grid leak-condenser detector, and a two-stage transformer-coupled a.f. amplifier. In the r.f. and first

a.f. stages 226-type tubes are used. The detector is a 227-type tube. The power tube is a type 171A. Plate voltages are obtained from a 280-type tube in a full-wave rectifier circuit.

FADA MODELS 10, 11, 30, AND 31 RECEIVERS

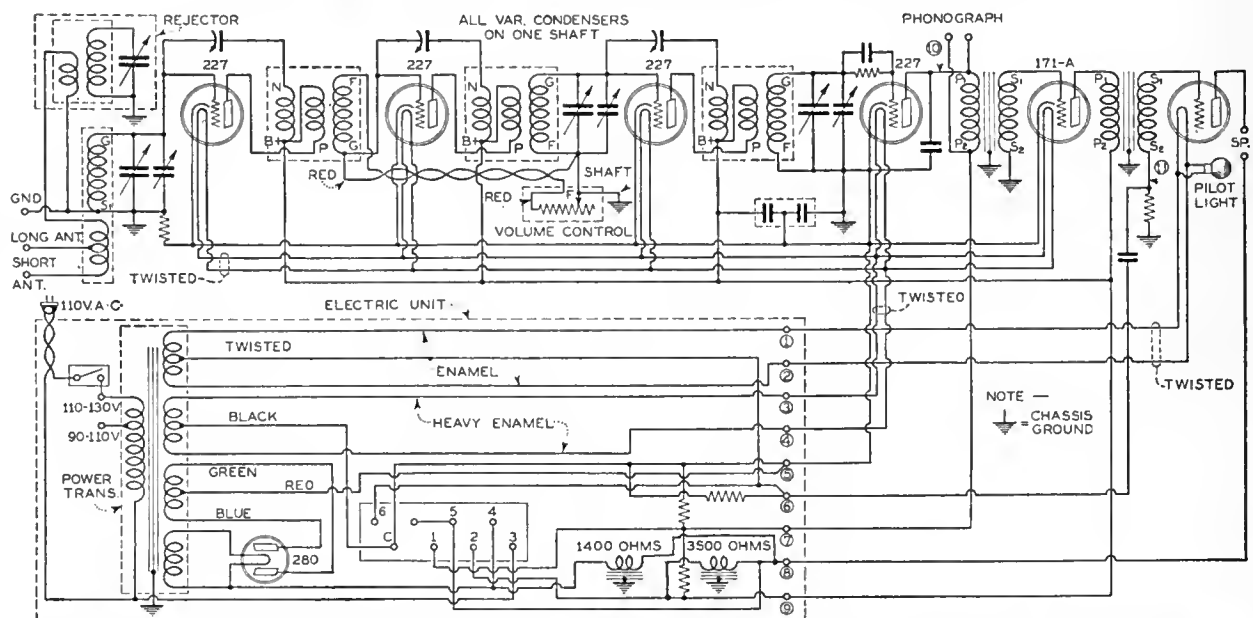

One of the unusual features about this Fada receiver is the use of a "rejector" circuit in the antenna stage. The primary of this rejector circuit is placed in series with the primary of the usual antenna transformer. The rejector circuit is not, however, tuned to the frequency of

the desired signals but is tuned so as to eliminate undesired signals. Another unusual feature is the use of an untuned r.f. transformer between the first and second r.f. amplifier tubes, the transformer being of such characteristics as to equalize the r.f. gain.

(Continued from page 167)

in whatever section the gang condenser does not tune accurately so that as the plates come into mesh the bent plate will have a closer spacing and so raise the capacity at the desired frequency setting.

"In neutralizing a receiver, the oscillator is set as for alignment of condensers and a dead or burned-out tube is placed in the first r.f. socket. The receiver is tuned to resonance, and the balancing condenser for that stage adjusted for *minimum* deflection of the output meter. Each r.f. stage is balanced in this way both on low and high frequencies.

"If an oscillator such as is described by Mr. Lampkin is a part of the shop equipment (and it certainly should be) some very interesting tests may be made on the efficiency of the a.f. systems of various makes of receivers. By changing the frequency of the a.f. oscillator and comparing readings or making graphs of the results obtained when the receiver's a.f. system is fed with frequencies ranging from the lowest to the highest a.f. note, the cut-off of the transformers, etc., may be determined.

"The human ear is very unreliable as a judge of volume in testing and fine adjustments of this nature as will be seen if a loud speaker is connected in parallel with the meter during tests.

"It may be necessary to insert a bias battery in the 199 grid return to reach zero reading with no signal input to the receiver."

Data on Atwater Kent sets: WALTER STRAUSS, JR. describes his experiences with A.K. screen-grid receivers:

"On one Atwater-Kent 60, three screen-grid tubes employed, it was necessary to hold down on the detector tube to hear signals, and when the hand was taken off the voice was distorted and weak with all the volume turned on. After taking off the base cover, an investigation revealed the grid leak touching the frame so that when the tube was pressed, the socket bent sufficiently to break the connection between the ground and the grid leak. The grid leak was raised a little with a piece of paper placed under it.

"Another quite similar incident occurred on the same model. In this case the music was weak and distorted, and tappings and knocks could not make the set play louder. So again the search was directed to the sockets of the 227 tubes in the detector and first a.f. stages. The analyzer showed something wrong in the grid circuit of the first a.f. stage. The secondary of the first a.f. transformer was o. k. and so was the resistor across the secondary of the transformer. With the continuity tester it showed that the resistor was grounded on both sides instead of only one. The other ground was found where solder on a wire was also making contact to the rivet nearby which held the sockets. The excess solder was removed. Another thing to watch for is that this resistor is not grounded to the frame as with the detector resistor. Don't always blame the 224's!"

Repairing a burned-out transformer: J. P. KENNEDY, radio serviceman of South Bend, Ind., and a student in E. E. at Notre Dame, suggests changing over to capacity coupling, with resistance or impedance in the plate circuit, for burned-out a.f. transformers not easily accessible for repair—the Radiola supers being an example.

"If, instead of going to the bother of repairing, let us say, a break in the plate circuit of the first a.f. stage, he simply binds a small wire around the plate terminal of the tube and solders the other end of it to one side of the 0.25-mfd. condenser and one end of a 50,000-ohm resistor, it is only necessary to attach the other

(Concluded on page 171)



WHILE your production line is turning out sets or amplifiers for this season's market your engineers are looking ahead. Decided improvements in Transformer design for the season to come is already an accomplished fact. Engineers in the Dongan Laboratories have developed innovations and refinements during the past six months which will unquestionably be accepted for the new models.

Exclusive devotion to the design and construction of Transformers, Chokes and Condensers over a period of 19 years has won for Dongan a leadership in Radio Parts. That, plus unfailing reliability for deliveries, has won for Dongan the patronage of the larger and better set and amplifier manufacturers.

New designs and engineering coöperation for the new models are available to any manufacturer.

*Exclusively M'fr's
of Parts for the
Set Manufacturer*

*Transformers
Chokes
Condenser Units*

Dongan Electric Manufacturing Co.

2991-3001
Franklin Street



Detroit
Michigan



Fulco RADIO COVERS

"FULCO" covers are used by those dealers who realize the importance of making deliveries in perfect condition — without scratches or mars. For they know that complaints mean dissatisfied customers and loss of business.

"FULCO" covers are a real service feature that helps sales and holds trade. Substantially constructed, heavily padded, box-shaped, providing perfect protection. Give us the dimensions of radios handled and let us quote special prices on your individual needs. Write our nearest house.



ON AND OFF
IN A JIFFY

Fulton Bag & Cotton Mills
Manufacturers Since 1870
ATLANTA · NEW ORLEANS · DALLAS · ST. LOUIS
MINNEAPOLIS · BROOKLYN · KAN. CITY, KAN.

THE MAJESTIC MODEL 90

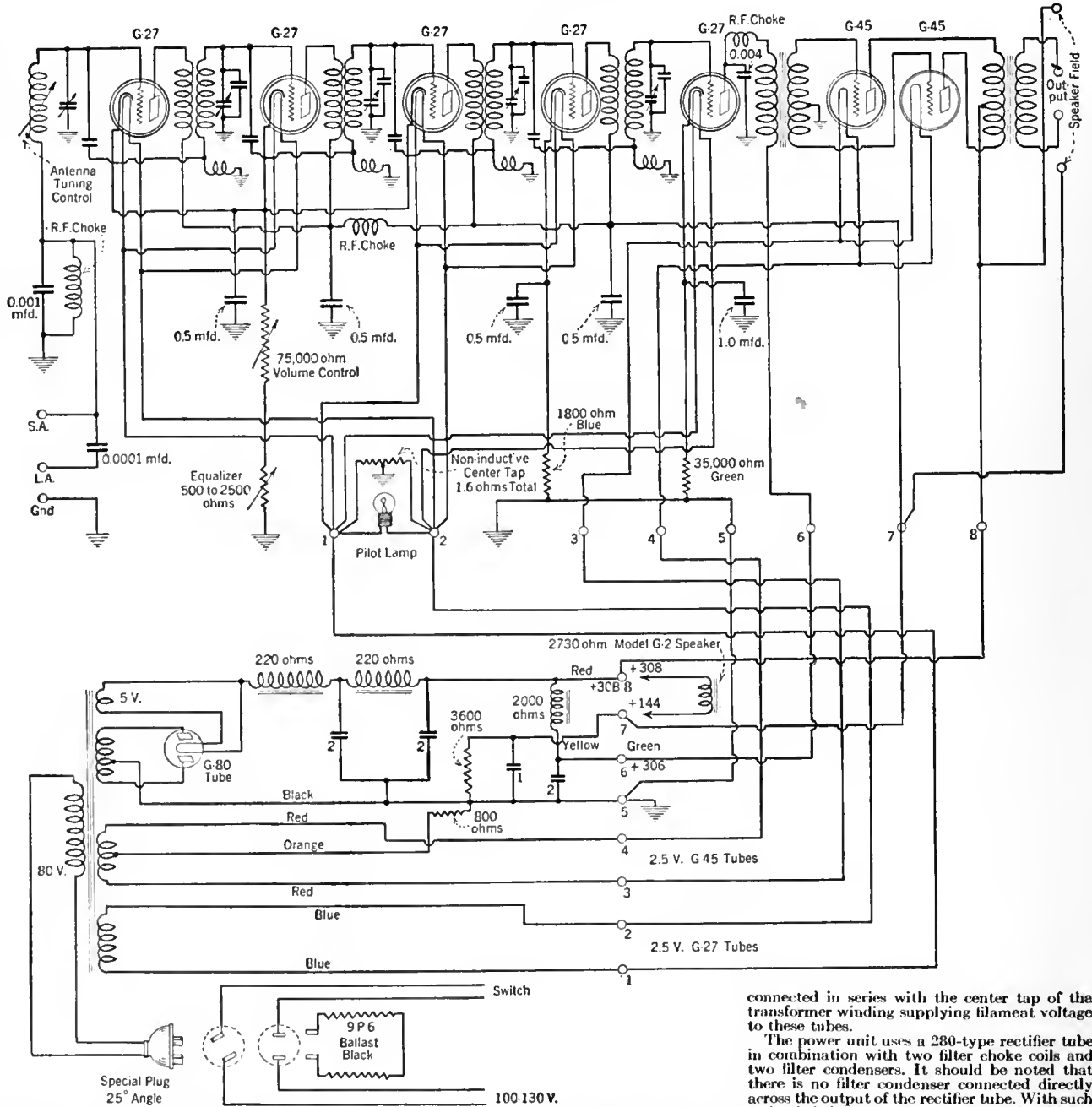

THE MAJESTIC MODEL 90 receiver uses the same fundamental type of radio-frequency amplifier circuits as did the previous Majestic receivers, Models 70, 70B, and 180. This set uses four stages of tuned-radio-frequency amplification followed by a C-bias detector and a single stage of audio-frequency amplification. There are five tuned circuits in the receiver, all of them controlled by the same tuning dial. Across the second, third, fourth, and fifth tuned circuits small compensating condensers are connected so that all the stages may be accurately tuned to resonance. The inductance of the antenna tuning circuit can be varied slightly so as to compensate the effect of the antenna circuit.

The volume output of the receiver is controlled by varying the grid bias applied to the first, second, and third r.f. amplifier tubes. For this control a variable resistor of 75,000 ohms is connected in series with the cathodes of the r.f. amplifier tubes. Increasing

the value of this resistor increases the bias on the tubes and thereby decreases the gain, causing a reduction in volume.

To make the receiver uniformly sensitive over the entire broadcast band, an equalizer circuit is used. This equalizer consists of a variable 500-2500-ohm resistor connected in series with a 75,000-ohm volume control. The shaft of this equalizer is mounted on the rotor shaft of the gang condenser so that as the rotor is turned in tuning the movable arm on the resistor unit moves correspondingly. The result is that an automatic variation in grid bias is obtained which is sufficient to compensate the normal variation in r.f. gain of the receiver.

Grid bias for the fourth r.f. amplifier tube is obtained by the use of a fixed resistor of 1800 ohms connected in series with the cathode of this tube. Bias for the detector tube is obtained by the use of a 35,000-ohm fixed resistor in the cathode circuit of the detector. The two 45-type tubes obtain their bias from an 800-ohm resistor

connected in series with the center tap of the transformer winding supplying filament voltage to these tubes.

The power unit uses a 280-type rectifier tube in combination with two filter choke coils and two filter condensers. It should be noted that there is no filter condenser connected directly across the output of the rectifier tube. With such a circuit it is necessary to use somewhat higher voltages across the secondary of the power transformer to obtain sufficient output voltage, but the advantage of such a system is that the load on the rectifier tube is much lighter than it would otherwise be and as a result the rectifier tube will have a long life. The full output of the filter circuit is used to supply grid and plate voltages to the two power tubes. This voltage is decreased for application to the other tubes in the receiver by connecting the field of the electrodynamic loud speaker in series with the high voltage tap so that the plate current of all the tubes except the power tubes must flow through the field winding. The resistance of the field winding is 2730 ohms.

The primary of the power transformer is wound for an input potential of 80 volts so that an automatic line voltage ballast may be used. This automatic ballast functions to supply approximately 80 volts to the primary of the power transformer even though the line voltage fluctuates between 100-130 volts.

READINGS WITH THE WESTON SET-TESTER MODEL 547

Type Tube	Tube Position	"A" Volts	"B" Volts	"C" Volts	Cath. Volts	Nor'l mA.	Test mA.
27	1 R.F.	2.3	150	14	19	3.4	6
27	2 R.F.	2.3	150	13	17	3.5	6
27	3 R.F.	2.3	150	13	18	3.6	6
27	4 R.F.	2.3	158	12	12	6.6	8
27	Det.	2.3	290	29	28	.8	1
45	P.P.	2.4	285	50		35	40
45	P.P.	2.4	285	50		35	40
80	Rect.	4.8				60	

VOLTAGE READINGS WITH SUPREME DIAGNOMETER

Use	Fil. V.	Plate V.	Grid V.	K.	P. Cur.
1 RF	2.35	130	8	8	5.5
2 RF	2.35	130	8	8	5.5
3 RF	2.35	130	8	8	5.5
4 RF	2.35	130	9	9	5
Detector	2.35	270	30	30	1
Power	2.45	250	50		32
Power	2.45	250	50		32

All readings under full load. Line voltage 115 volts.

(Continued from page 169)

end of the resistor to the 90-volt positive B terminal and the other side of the condenser to the grid terminal of the following tube to get results.

"If the break is in the grid circuit of an a.f. tube, a 150,000-ohm resistor should be bridged from the grid of the tube to the negative end of the 4.5-volt C battery wire and the same size condenser should be connected, as in the previous case, from the plate of preceding tube to the grid of the tube in question."

Nuts and Bolts and Antennas: "When going on service trips, I always carry a light-socket antenna with me. Its use is obvious. If you suspect that the outdoor antenna is in any way contributing to the set's defect, your suspicions may be verified easily or refuted by a temporary substitution. True, many of the modern sets are equipped with such socket antennas but it must be remembered that a majority of the sets one is called on to repair give the impression that they are the radios which accompanied Noah on his famous personally conducted tour.

"I have always made it a point to carry a varied assortment of radio hardware; nuts, bolts, screws, lugs, etc. Just a few of each in a small cardboard box will be sufficient. This seems rather obvious yet I have seen numerous repair kits which neglected such necessary equipment. The radio man will be getting a reputation such as the plumber has earned through his forgetfulness and frequent trips back to the shop, if he doesn't watch out.

"One summer I was called upon to service an Atwater-Kent 35 which I had installed the previous winter. Inspection proved the antenna to be guilty. One end had been

attached to a tree and newly grown branches and leaves were rubbing against it, creating the disturbance. A little emulsion of the lumberjack and a peaceful silence reigned where had been chaos and discord. Moral: Use a little forethought in erecting an antenna."

BERNARD CANNON, Pittsburgh, Pa.,
Majestic and S-M.

More Dope on Hum Elimination: The following letter has been in our files for some time. Our first impulse was to include it in one of our symposiums on hum reduction. On second thought that was not quite the place for it. But it certainly deserves publication somewhere—so here it is:

"I present the following as a matter of interest and not because it presents the solution of a particular problem. Many a serviceman may get a laugh from it.

"A most drastic method of removing hum from an a.c. set just came to my attention. A friend of mine, a plumber by trade, had an Atwater-Kent. After being in service some time a wire became disconnected. It caused a buzz or hum and was very annoying. Upon inspection he discovered the loose wire and saw immediately that a little solder was all that was necessary to make the set operate as it should. He had no iron at hand so got out his blow torch, fixed the flame as small as possible and turned it on the bad connection. Have you in all your experience heard the beat of that? The wire was difficult of access. More flame, more heat, and then the metallic clank of various small members falling on the chassis. The hum was removed and so was everything else that makes radio, radio.

"I certainly enjoy your magazine.
BYRON E. LAIDLAW, Crestwood, N. Y."

A RADIO DEALER'S TUBE-TESTER

(Continued from page 145)

a standard circuit using the rectifier tube to deliver current to a fixed load resistance. A low current through this resistance shows a defective tube. The circuit (Fig. 3) is arranged to use a standard center-tapped transformer delivering 600 to 700 volts and having a 5.0- and a 7.5-volt filament winding. A switch is provided to change connections from 380 to 381 tubes, this change consisting of changing the load resistance as well as the transformer connections. As can be seen from the circuit, the 380 tube is used with 300 to 350 volts on each plate and delivers current to a 4-mfd. condenser and a 2000-ohm load resistance which has a 0-200-scale milliammeter in series with it. The 381 tube is used with 600 to 700 volts at 60 cycles on the plate and delivers current to the 4-mfd. condenser with a 6000-ohm load. The test consists of inserting the tube in the proper socket, making sure the switch is thrown to the correct side. The milliammeter should read something over 100 mA. for the 380 and something over 60 mA. for the 381, though these readings depend on whether a 600-volt or a 700-volt transformer is used. For the higher voltage the limits can be raised 10 mA. and for intermediate voltages, allowances made.

In the drawing a typical layout of this circuit is shown. It is preferable to keep the tube socket terminals beneath the panel to avoid shocks. A conventional double-pole double-throw tumbler switch is shown. The 4-mfd. condenser must be a good one capable of working continuously at 1000 volts. d.c. The load resistor must have a high current carrying capacity, the Electrad type C or D being satisfactory.

The equipment listed in Table III was used in the original model but any equivalent parts will give satisfactory results.

Table III

- T₁—One Amertran PF52A transformer, 110-115-V. 60-cycle primary having 300 volts each side of center of secondary (capable of delivering at least 85 milliamperes in each half of the high winding) and having two 7.5-volt windings, both insulated for 1000 volts from other windings. This particular transformer, since it has two 7.5-volt windings, required a 1-ohm and a 1/2-ohm Carter type 11 resistor in series with the filament terminals of the 380 socket to reduce the voltage to 5 volts. A transformer having two 5-volt windings and a 2.5-volt winding could also be used, one five-volt winding being used for the 380 and the other two (the 5 and the 2.5 volt) connected in series to provide 7.5 volts for the 381.
- C₁—One Acme Parvold condenser, 4-mfd. 1000-volt
- M₁—One Weston model 301, 0-200 milliammeter.
- R₁—One Electrad type D, resistor, 2000-ohm
- R₂—One Electrad type D, resistor, 400-ohm
- Two tube sockets, cx-type
- K₁—General Electric switch, double-pole, double-throw (Catalogue No. 289739)
- K₂—General Electric tumbler switch, single-pole (Catalogue No. 269943)

[For those dealers and servicemen who prefer to buy ready-made apparatus, there are a number of tube-testers as well as apparatus designed for overall measurements on receivers, which will perform some of the measurements which the apparatus described in this article will do. Some commercial equipment will carry out all the tests, including short-circuit tests, etc. The circuit which includes a C-bias resistor part of which can be shorted to get the worth of the tube is covered by a patent issued to the Weston Electrical Instrument Co. Other tube-tester manufacturers are licensed under this patent. Efficient and inexpensive apparatus for testing tubes may be purchased from the instrument makers, a number of whom may be found advertising in RADIO BROADCAST. This article is published for those who already have some of the apparatus available (meters etc.), and for those who enjoy making their own equipment.—The Editor.]

"Here at last is The Book that we of the Radio profession have needed for a long time. It is the best and most complete handbook ever published," says J. H. Bloomenthal, Chief Radio Operator, U. S. S. B. Steamship "East Side,"

THE RADIO-MANUAL

A New Edition

Complete new chapters on aircraft radio equipment; Practical Television and Radiomovies with instructions for building a complete outfit; radio interference; 100% modulation; latest equipment of the Western Electric Co.; the Marconi Auto-Alarm System; and many other developments of the past year. All this information is added in the new edition and, besides, the entire book has been brought right up to date with much new material. *The Radio Manual* continues to be the one complete and up-to-the-minute handbook covering the entire radio field.



A Handbook for Students Amateurs Operators Inspectors

20 big chapters cover: Elementary Electricity and Magnetism; Motors and Generators; Storage Batteries and Charging Circuits; The Vacuum Tube; Circuits Employed in Vacuum Tube Transmitters; Modulating Systems and 100% Modulation;

Wave-meters; Piezo-Electric Oscillators; Wave Traps; Marine Vacuum Tube Transmitters; Radio Broadcasting Equipment; Arc Transmitters; Spark Transmitters; Commercial Radio Receivers; Marconi Auto-Alarm; Radio Beacons and Direction Finders; Aircraft Radio Equipment; Practical Television and Radiomovies; Eliminating Radio Interference; Radio Laws and Regulations; Handling and Abstracting Traffic.

An immense amount of information never before available including detailed descriptions of standard equipment is presented.

Prepared by Official Examining Officer

The author, **G. E. Sterling**, is Radio Inspector and Examining Officer, Radio Division, U. S. Dept. of Commerce. The book has been edited in detail by **Robert S. Kruse**, for five years Technical Editor of QST, the Magazine of the American Radio Relay League. Many other experts assisted them.

Free Examination

The new edition of "The Radio Manual" has just been published. Nearly 900 pages. 369 illustrations. Bound in Flexible Fabrikoid. The coupon brings the volume for free examination. If you do not agree that it is the best Radio book you have seen, return it and owe nothing. If you keep it, send the price of \$6.00 within ten days.

Order on This Coupon

D. Van Nostrand Co., Inc.,
250 Fourth Ave., New York

Send me the Revised edition of THE RADIO MANUAL for examination. Within ten days after receipt I will either return the volume or send you \$6.00, the price in full.

(Radio Broadcast 1-30)

Name.....

St. & No.

City and State.....

THE A. C. DAYTON NAVIGATOR

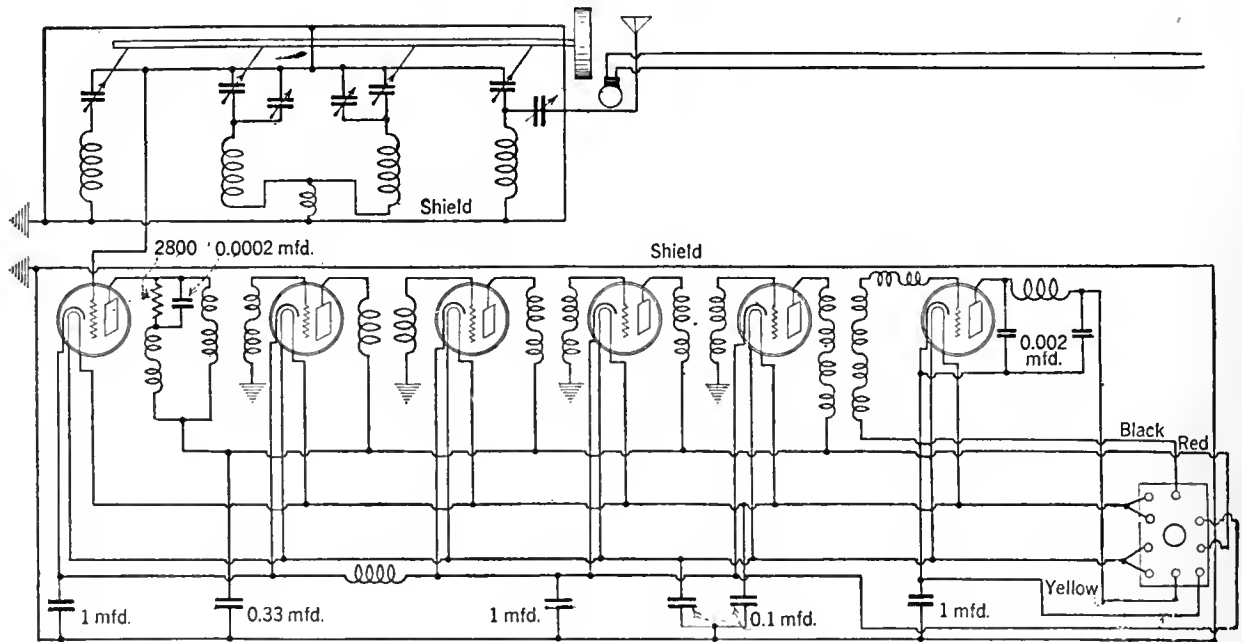

THE A-C DAYTON NAVIGATOR receiver, the circuit of which appears on this sheet, is an example of a set using a system of "pre-selection" in which the signals to be received are selected by several tuned circuits before they reach the first r.f. amplifier tube. Reference to the circuit diagram shows that the tuning dial controls the setting of four variable condensers, each of which functions to tune a circuit to resonance. There are, therefore, four tuned circuits between the antenna and the grid of the first r.f. amplifier tube. Induced in the antenna circuit are signals from all broadcasting stations, but in the process of passing through the various tuned circuits all of these except the desired one are eliminated. Although there are many different signals across the input, in the output of the selector there is only one signal—the desired signal to which the various circuits have been tuned.

THE R. F. AMPLIFIER

After this signal goes through the tuned stages it reaches the first tube of the r.f. amplifier. In the r.f. amplifier there are five tubes and each of these functions to amplify the desired signal. The r.f. amplifier is untuned, that is, it is designed to amplify a signal of any frequency in the broadcast band that is impressed on its input. Since the selector circuits weed out all but the desired signal, the amplifier functions to amplify this signal whether it be from a station transmitting on 500 kc., 1000 kc., or any other frequency in the broadcast band.

The difference between the system described above and that used in many other receivers should be noted. In most sets a tuned circuit is placed between each tube so that the processes of selection and amplification occur in the same circuit. In this receiver the functions of selection and amplification are separate, the signal is first selected and then amplified.

THE DETECTOR CIRCUIT

The output of the r.f. amplifier supplies voltage to a C-bias detector operated at sufficiently high grid and plate voltages (see table) so that it can supply enough a.f. output to operate the two 245-type push-pull tubes at

their maximum power. It should be noted that in the plate circuit of the detector tube there is an r.f. filter circuit consisting of r.f. chokes and two 0.002-mfd. condensers. This filter circuit bypasses to the heater of the detector all the r.f. currents in the plate circuit so that only audio-frequency currents will be applied to the primary of the a.f. transformer.

Plate voltage for all the tubes is obtained from the 280-type-rectifier tube which feeds into a filter circuit consisting of two chokes (one of which is the field of the electrodynamic loud speaker) and a three-section Mershon condenser

with a capacity of 8 microfarads per section. The primary of the power transformer is tapped for various line voltages from 105 to 125.

EASE OF SERVICING

In servicing the receiver the fact that the set is made up of three separate sections—the selector, the r.f. amplifier, and the power amplifier and B supply—makes it possible to readily remove any one section and replace it with a new unit while the defective unit is being repaired. The chart of voltage and current readings given on this sheet will prove helpful in determining whether or not the various circuits are receiving the correct voltages and whether the plate current at these voltages is normal.

The fact that the r.f. amplifier is of the untuned type makes it possible to determine readily whether or not the selector unit is in proper working order. For example, if the set does not seem to have very much gain it might be due to some defect in the selector and this could be checked readily by removing the antenna from its usual location at the input of the selector and connecting it instead to the contact between the selector unit and the r.f. amplifier. If the signals from any local station then come in with tremendous volume it is a definite indication that the loss in gain is due to some defect in the selector which can then be removed and replaced with a new unit.

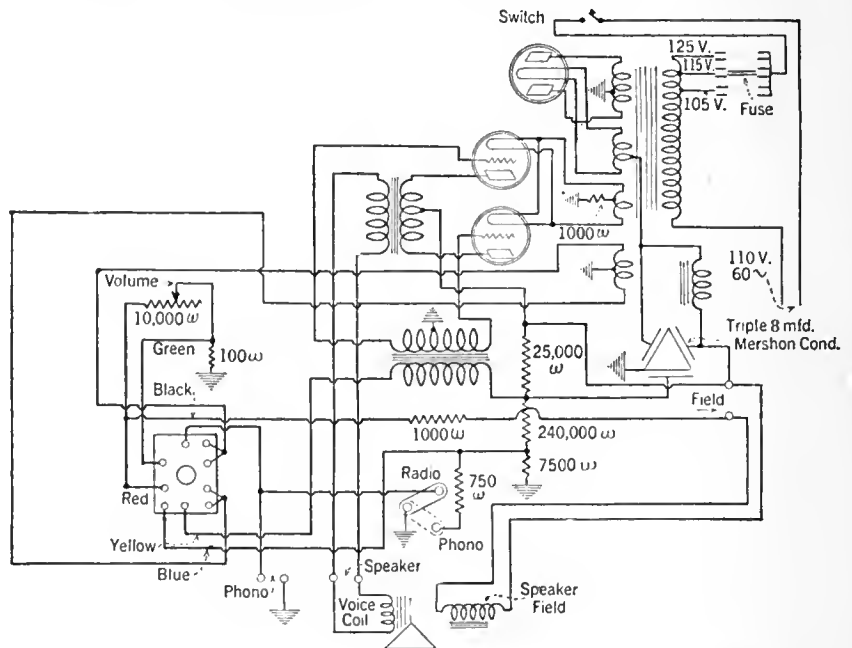

AVERAGE VOLTAGE READINGS OF THE A.C. DAYTON NAVIGATOR RECEIVER

Tube Number	Tube Type	Function of Tube	Heater Volts	"B"—Plate Min. Vol.	"B"—Plate Max. Vol.	"C" Bias Min. Vol.	"C" Bias Max. Vol.	Normal Plate mA.
1	27	1st. r.f.	2.4	20	110	4.5	3.5	4.5 to 5.0
2	27	2nd. r.f.	2.4	20	110	4.5	3.5	4.5 to 5.0
3	27	3rd. r.f.	2.4	20	110	4.5	3.5	4.5 to 5.0
4	27	4th. r.f.	2.4	20	110	4.5	3.5	4.5 to 5.0
5	27	5th. r.f.	2.4	20	110	4.5	3.5	4.5 to 5.0
6	27	Detector	2.4	180	185	15	15	1.0
7	45	Audio	2.4	230	230	50	50	20 to 24
8	45	Audio	2.4	230	230	50	50	20 to 24
9	80	Rectifier	4.75	330	330			

Note: The above readings for "Detector" are given with the "Phono-Radio" switch in the "Radio" position. With this switch in the "Phono" position, the detector should have the following readings: Plate Volts= 120; "C" Bias= 4.0 volts; Plate current = 5.0 mA.

A REFLEX VACUUM-TUBE VOLTMETER

THE ORDINARY vacuum-tube voltmeter has the disadvantage that its range is quite limited, generally being not more than about 3:1 in voltage. By the use of an arrangement whereby the plate current is caused to flow through a resistance which functions to increase the bias on the grid of a tube, it is possible to increase the range of the instrument almost indefinitely. Such a device is called a "reflex" voltmeter.

The first reflex voltmeter which came to the attention of the writer was one described by W. B. Medlam and U. A. Oswald in the November, 1926, *Experimental Wireless and Wireless Engineer* (England). A description of a reflex voltmeter formed part of an excellent series of articles by these two engineers. In Fig. 1 is given a calibration curve of a reflex voltmeter taken from the previously mentioned article. On the curve is shown the circuit arrangement used. It should be noted that the plate current, in order to get to the filament, must flow through the resistance R, and that increases in the current through R will also increase the bias on the grid of the tube. The calibration curve of a reflex voltmeter is quite linear, in this particular case we find that from about 3 volts to 20 volts each increase of 10 microamperes in plate current corresponds to an increase of 2 volts on the input. The steady bias, E_c , is used so that the plate current will not be excessive when the a.c. input voltage is zero.

In Fig. 2 is given the circuit diagram of a reflex voltmeter using a 227-type tube. This should make a very useful instrument. It should be possible to supply the voltmeter from a rectifier and filter system so that the instrument could be entirely self-contained and light-socket operated.

plate current. The value of resistor R_2 is not critical; its value should simply be much greater than the resistance of the galvanometer so that the entire increment in plate current will flow through the galvanometer and not through R_2 .

Vacuum-tube voltmeters are generally calibrated by connecting known a.c. voltages across their input, noting the corresponding plate current, and finally plotting the calibration curve showing the variations in plate current with input voltage. It is, however, possible to use a static characteristic curve to calculate

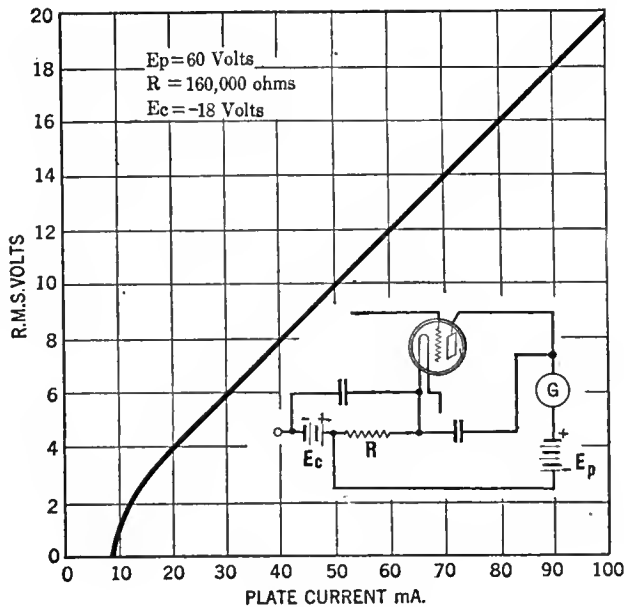

Fig 1

the calibration curve of a simple voltmeter by any one of several methods. Medlam and Oswald give a simple method in their article. To determine the calibration from the static characteristic curve, we must know the plate current corresponding to:

- E_c the steady bias on the grid
- E_f the steady bias plus the peak value of the a.c. voltage
- E_t the steady value minus the peak value of the a.c. voltage

Knowing these three quantities it is possible to calculate within two or three per cent, the mean plate current as read on the plate current meter, by means of the following simple relationship.

$$I_m = \frac{I_c}{2} + \frac{I_f + I_t}{4}$$

- where I_m = reading of the plate meter
- I_c = plate current corresponding to E_c
- I_f = plate current corresponding to E_f
- I_t = plate current corresponding to E_t

Consider the following example. We desire to determine what would be the reading of the plate meter if a peak a.c. potential of 1 volt were applied to the grid. Assume that the steady bias on the tube is minus 3 volts. Therefore,

$$\begin{aligned} E_c &= -3 \\ E_f &= -3 + 1 \text{ or } -2 \text{ volts} \\ E_t &= -3 - 1 \text{ or } -4 \text{ volts} \end{aligned}$$

From an accurately measured static characteristic curve, we determine that I_c is 10 microamperes, I_f is 34.1 microamperes and I_t is 1.7 microamperes. Substituting in the formula, we have

$$\begin{aligned} I_m &= \frac{10}{2} + \frac{34.1 + 1.7}{4} \\ I_m &= 13.95 \end{aligned}$$

By actually applying an a.c. voltage having a peak value of 1 volt to this tube it was found that the plate meter read 14 microamperes, which agrees very closely with the calculated result.

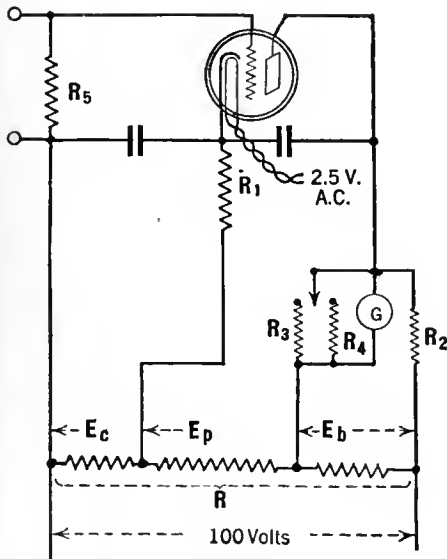
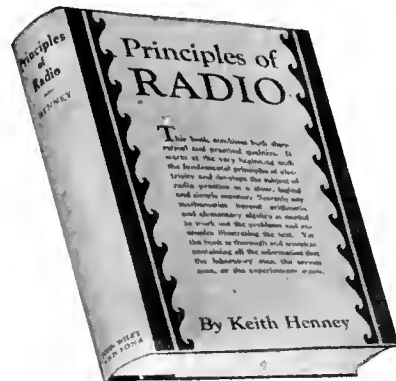

Fig. 2

To balance out the steady plate current flowing through the plate microammeter, when there is no input voltage, connection is made through resistance R_1 to the plate side of the meter and the potential E_b is adjusted so that the current through G is exactly equal and opposite to the steady

Just Out . . . Keith Henney's Book on Radio



Principles of Radio

By KEITH HENNEY

Director of the Laboratory
Radio Broadcast Magazine

Readers of Radio Broadcast, long familiar with the work of Keith Henney in his capacity as Director of the Magazine's Laboratory, will be eager to secure his first book, just released from the press.

This book brings together within one cover the kind of information on radio which will appeal to the practical interest of every radio experimenter, technician, engineer, and fan. It contains the latest data and the most modern methods. It treats in a thoroughly practical way everything from the production of radio currents to their reception and transmission. Many problems, examples, illustrations, experiments, are here presented in book form for the first time.

Keith Henney, by reason of his wide experience as an operator, engineer, and writer, has the gift of making technical information readily understood by the reader.

See a Copy on Ten Days'
Approval

Price \$3.50

A Wiley Book

ON APPROVAL COUPON

JOHN WILEY & SONS, INC.
440 Fourth Ave., New York City

RB 1-30

Gentlemen: Kindly send me on approval Henney's "Principles of Radio." I agree to remit the price (\$3.50) within ten days after its receipt or return the book postpaid.

Name

Address

Reference

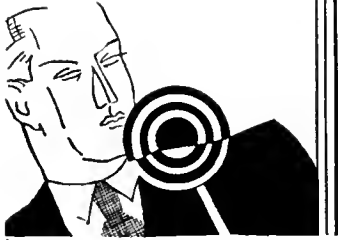

RADIO

De Forest Wins General Electric Co. Suit

The Court of Appeals of the Third Circuit, in a decision just handed down, has confirmed the right of the DeForest Radio Company to the use of high vacuum in its audions, and has discharged the suit brought against this company by the General Electric Company. This decision is held to be of outstanding importance, since it removes the sole remaining question regarding the enviable tube patents position of the DeForest Radio Company.

The suit for patent infringement was instigated by the General Electric Co. against the DeForest Radio Co. in April, 1925, charging infringement of the so-called Langmuir high-vacuum patent. The original trial lasted five weeks, with the District Court finally holding that the patent was invalid. The decision was appealed by the General Electric Company, and has now been confirmed by the Court of Appeals. If the so-called Langmuir high-vacuum patent had been sustained, it would have placed its owner in control of the radio tube industry.

The decision declares invalid three patents covering the use of a high vacuum in a vacuum tube, the use of thoriated filament in high vacuum, and the use of the magnesium flash in a high vacuum.

Receiver Appointed for Earl

Receivers were named on application of creditors late in November for the Earl Radio Corporation, New York. Principal creditors are the Klamer Furniture Company, Evansville, Ill., \$500,000; Westinghouse, \$56,000. Arcturus Radio, \$250,000; Scoville, \$150,000; and Erickson Manufacturing Company, \$31,000. Attorneys for Earl announce consent to the receivership as a protection to creditors and state that a reorganization to obtain larger working capital is under way.

Studebaker Enters Radio

The Studebaker interests, of South Bend and Chicago, have acquired substantial holdings in the Marvin Radio Tube Corporation, according to Thomas F. James, president. Col. George M. Studebaker will become chairman, with F. H. Wellington treasurer. The directorate will be increased to include Colin B. Kennedy, president of the Colin B. Kennedy Corporation; Hiram H. Maynard, of the H. H. Maynard Corporation; Col. Studebaker; and F. H. Wellington.

Rauland Returns to Radio

E. N. Rauland, formerly of the All-American Transformer Company, Chicago, Ill., is president of the Rauland Corporation, 3341 Belmont Ave., Chicago. All types of a.f. transformers will be made from a replacement transformer at \$2.25, to a standard shielded model at \$4.50, and the laboratory type at \$7.50. Special power amplifiers have been developed in collaboration with Jenkins and Adair. The company also makes ultra-violet sun lamps.

General Motors' Officials Attend Convention



"Building for the future by building right" was the keynote of the first convention of district managers of General Motors Radio Corporation at the company's plant in Dayton, Ohio, October 24 and 25, 1929, with John E. Grimm, Jr., vice president and director of sales, in charge.

Plans for fall selling were outlined and it was announced that the General Motors Radio Corporation would continue the manufacture of the Day Fan Radio receivers. Advertising plans were outlined by Mr. Rothman and W. A. P. John, vice president of the Campbell-Ewald Company, the company's advertising counsel. The company's advertising policy, it was announced, would be to handle all advertising on a controlled basis for both distributors and dealers, which met the

approval of all district managers and officials present.

At a banquet at the Van Cleve Hotel, Mr. Emmert outlined the engineering and manufacturing plans of the company. The convention was brought to a close with an address by R. H. Grant, who discussed the future of the radio business as seen by General Motors.

Officials of the company attending the convention are pictured above. They are from left to right: (upper row) Charles T. Lawson, general sales manager; E. E. Rothman, advertising manager; John F. Reeder, Campbell-Ewald Co., advertising counsel; (lower row) John E. Grimm, Jr., vice president and director of sales; R. H. Grant, vice president in charge of sales of General Motors; R. J. Emmert, president and general manager.

R. S. M. A. To Expand

Service managers outside of New York who are interested in forming branch service managers associations are urged to communicate with G. C. Kirchhof, executive secretary R.S.M.A., at their new address 324 West 42nd Street, New York. Branch associations will secure copies of the examination questions used by the parent organization in registering servicemen, necessary forms, including certification cards, office records, and copies of the new official publication of the R. S. M. A., *The Radio Service Man*.

N. F. R. A. Survey

A committee of the Radio Wholesalers Association is making a nation-wide survey on the handling of sets, tubes, and accessories by radio wholesalers. A report of findings will be made at the Cleveland Convention in February. Other committees of the Radio Wholesalers Association will investigate the handling of vacuum tubes and accessories.

Radio In Schools

South Dakota has announced plans to install radio in all the 5000 schools of the state within the next two years, with a regular semi-weekly broadcast by the State Department of Education as part of the regular educational program, in addition to broadcasts from other stations. The action is in line with developments in other states. Quinton Adams, vice president of the Radio-Victor Corporation, has announced that within the last few months thirty schools in the United States have installed built-in centralized radio apparatus for distribution of educational programs to classrooms and that between sixty and seventy other schools are planning similar installations.

New Experimental Station

The DeForest Radio Company will construct a five-kilowatt transmitter at its Passaic plant. The new station will be used for research and test purposes in the radio transmitter field.

INDUSTRY

500 Dealers Receive Dept of Commerce Questionnaire

Marshall T. Jones, of the Bureau of Foreign and Domestic Commerce, is mailing to four- or five-hundred representative dealers an unusually complete questionnaire covering all angles of retail trade. Among other fundamentals the survey asks the relation of parts business done by a dealer to all other business, facts on the dealer's service methods, whether part time servicemen are employed, number of sales made after 6 P.M., to whom sales are made, how shipments are forwarded from distributors, trade papers received, local interest in short-wave reception, etc.

A Book on Radio Law

A new book, *Radio Law*, by W. Jefferson Davis, published by Parker, Stone and Baird Co., Fourth and Wall Streets, Los Angeles, Calif., has just been issued. This volume is an excellent source for those who have occasion to follow the legal course of radio during recent years. The text covers decisions of the Federal Radio Commission and briefs of cases coming before the courts on state, national, and municipal regulation of radio. It also considers copyright, slander, world radio codes, the Washington Convention, and procedure before the Federal Radio Commission. It has a useful index and appendix.

Will Not Change Price

A number of manufacturers have reduced prices of 1929 models. Full details are given in this issue on page 181. The following manufacturers, however, have announced that no changes in prices will be made covering current models: Zenith, Philco, Edison, Grebe, Silver, Steinite, and Bosch.

Bosch Adds to Plant

An addition to Plant A of American Bosch at Springfield is now under way and is due to be completed early in January.

Personal Notes

G. J. Hallam, for the past three years assistant merchandise manager of the home furnishing division of the Associated Merchandising Corporation, has been appointed general sales manager of the De Forest Radio Company, Jersey City, N. J. Mr. Hallam succeeds Harry Holmes who recently resigned.

McMurdo Silver, president of Silver-Marshall, Inc., is now back at his desk after a month's absence due to injuries incurred in an automobile accident.

N. O. Williams, chief engineer and vice president of the CeCo Manufacturing Company, Providence, has been made works manager.

John E. Grimm, Jr., formerly with the Delco-Light Company, Dayton, Ohio, has been appointed vice president and director of sales of the General Motors Radio Corporation. He was formerly with the sales division of the Chevrolet Motor Car Company.

Charles J. Ross, formerly comptroller of R. C. A., has been elected executive vice president of R. C. A. Photophone, Inc. He succeeds E. E. Bucher who was recently appointed assistant vice president of the Radio Corporation of America.

W. R. G. Baker, has been selected to head the engineering division of the new RCA-Victor Corporation, with the title of vice president in charge of engineering. Mr. Baker will make his headquarters at Camden, N. J. He is at present in charge of radio engineering and manufacturing at the General Electric Company at Schenectady.

L. T. Breck, sales manager for the Kolster Radio Corporation for the past year, has been elected vice president in charge of merchandising to succeed Major Herbert H. Frost, who recently resigned.

Glenn Browning, has been retained by the Temple Corporation to work on special problems relating to radio development. Temple now has nineteen graduate engineers in the permanent staff.

LeRoi J. Williams has been appointed director of patents for the Grigsby-Grunow Company. Mr. Williams was formerly associated with the Raytheon Manufacturing Company, the General Electric Company, the Westinghouse Company, and the Radio Corporation of America.

James T. Bristol has been made General Manager and executive head of the Majestic Corporation which has been organized to finance installment sales of Majestic radios.

J. R. Aray has been appointed chief service engineer of the Grebe Sales Company. Mr. Aray

Edison Discontinues Making Records

Thomas A. Edison, Inc., has discontinued the manufacture of commercial phonograph records (including both diamond disc and needle types) in order to make available additional factories for the manufacture of radio and radio-phonograph combinations on an augmented scale, according to announcement by Arthur L. Walsh, vice president of the corporation. Mechanical phonographs of the portable type will be continued to be manufactured and sold as heretofore.

Minnesota Service Organization

The Associated Radio Service Engineers, 301 Tribune Annex, Minneapolis, Minn., was organized in May, 1929, with more than forty charter members. Meetings are held each Monday evening. The association is affiliated with the Northwest Radio Trade Association and all members have passed the registration examination for servicemen given by that organization. H. E. Knox is president, C. E. Graves, vice president, M. N. Flemming, secretary, C. L. Larson, treasurer, Earl Gibbs, director, and H. H. Cory, executive secretary.

was formerly chief sound technician at the Paramount Studios.

Nathan Chirelstein, of the Sonatron Tube Company, has been made president of the National Union Radio Corporation. Mr. Chirelstein, with his brother, Harry Chirelstein, embarked on his radio career in 1922 at which time Chirelstein's Radio Tube Corporation was formed. Three years later it became the Sonatron Tube Company.

Edward B. Newill has become affiliated with the radio manufacturing company being formed jointly by the General Motors Corporation and the Radio Corporation of America. Mr. Newill was formerly manager of the Control Engineering Department of the Westinghouse Electric and Manufacturing Company.

George M. Cook has been appointed director of public relations of the Grigsby-Grunow Company. Mr. Cook has held similar positions with the Stan-

(Continued on page 176)



The new eight story addition to the plant of the Crosley Radio Corporation is so spacious that as many as 600 employees can work on set assembly on a single floor.



The World's Premier Custom-Built RADIO

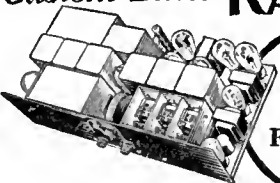

Built With WORLD FAMOUS PARTS

JUST like adding two and two to get four—the result is inevitable when you combine a most efficient circuit with parts the whole radio world respects.

The "HiQ-30" Receiver is Hammarlund-designed and Hammarlund-built. Eighteen years of producing precision telegraphic, telephonic and radio instruments is the insurance of quality which you get in every Hammarlund product.

Write Dept. RBI for Circular

HAMMARLUND MANUFACTURING CO.
424-438 W. 33rd St., New York, N. Y.

For Better Radio
Hammarlund
PRECISION PRODUCTS

! ATTENTION! SERVICE MEN

Quality Replacement Blocks and By-Pass Units for Radio Receivers "B" Eliminators Power Supply Units

THE POTTER CO.
1950 Sheridan Road, No. Chicago, Ill.

Please send latest condenser information for Repair and Service Work.

Name.....
Address.....
City..... State.....
Classification.....
Party in Charge of Purchases.....

DEALER—SERVICE MAN

RB-130

(Continued from page 175)
dard Oil Company and Swift and Company and was connected with the Associated Press for fifteen years.

Lester Abelson, general production manager of the Steinite Radio Company, is developing several unique methods of checking and improving efficiency in the new Steinite plant. An automatic counter, similar to a taxicab meter, has been installed on his desk which clicks off the number of each completed radio set as it leaves the factory.

David Grimes has joined the research staff of the Temple Corporation in Chicago.

P. P. Huffard, formerly vice president and general manager of the National Carbon Company, a subsidiary of the Union Carbide and Carbon Corporation, has been elected president of that company. He succeeds W. J. Knapp who is now chairman of the board.

Curtiss Abbott, formerly general sales manager of the Eveready Radio Corporation, has been appointed manager of the Pacific Northwest territory for Philco.

Ira B. Lamphier has been appointed a director of the Package Research Laboratory, Rockaway, New Jersey. In his new capacity, Mr. Lamphier will continue the work of package design and construction that he has been carrying on for several years.

J. J. Steinharter, president, Cable Radio Tube Corporation, left New York recently for a trip to the Pacific Coast in the course of which he will visit Los Angeles, San Francisco, Portland, and Seattle.

Lester Noble, formerly president of Federal Radio

Complaint Against Freshman

Charging that the Charles Freshman Company, Inc., of New York, manufacturers and dealers in radio receiving apparatus, acquired control of a competing company, the Freed-Eisemann Radio Corporation, of Brooklyn, N. Y., the Federal Trade Commission has issued a complaint against the Freshman Company, according to information made available by the Commission on October 31.

More than 250,000 shares of the stock of the Freed-Eisemann Corporation were obtained by the Freshman company, the complaint alleges. "The effect of the acquisition by respondent of said capital stocks of Freed-Eisemann Radio Corporation or the use of such stocks by the voting or granting of proxies, or otherwise," it was stated in the complaint, "may be and is to lessen substantially the competition between respondent Charles Freshman Company, Inc., and Freed-Eisemann Radio Corporation."

Coming Events

February 10-11, 1930. Cleveland, Ohio. Fourth Annual Convention of National Federation of Radio Associations, Radio Wholesalers Association, Statler Hotel.

Week of June 2, 1930. Atlantic City. Annual Trade Show and Convention Radio Manufacturers' Association. Convention Hall.

Corporation, has been elected president of the United Reproducers Corporation, Springfield, Ohio. Arthur B. Hill, former president, has resigned.

Major I. E. Lambert is vice president and general counsel, RCA-Victor Company, Inc. E. C. Grimley is treasurer and comptroller. Both were former officers of the Radio-Victor Corporation.

A. H. Meyer, of Leo J. Meyberg Co., has been elected president of the Pacific Radio Trade Association. Other officers are Robert Eastman, vice president, Ernest Ingold, E. G. Arnold, H. R. Curtiss, Harrison Hollway, C. L. McWhorter, W. H. Quarg, and L. B. Quimby.

Byron P. Minnum, formerly chief engineer, Radio Division, Stewart-Warner Corporation, has joined the Baldwin Piano Company in Cincinnati, Ohio, as head of their Radio Division.

Carl Dreher, formerly chief engineer of RCA Photophone, Inc., prior to that staff engineer of the National Broadcasting Company, and for four years a regular contributor to RADIO BROADCAST as author of "As the Broadcaster Sees It," is now located in Hollywood, California as director of sound for RKO Pictures, producers of Radio Pictures.

The Northwest Radio Trade Association, at its annual election of officers held recently in connection with the Northwest Radio Show in Minneapolis, chose by a unanimous vote, J. W. A. Henderson as its president for the coming year.

Sylvan Harris, formerly with the Brandes Laboratories, Newark, New Jersey, has joined the engineering staff of F. A. D. Andrea, Inc., Long Island City, New York.

Pilot's Flying Laboratory

A large new airplane, specially constructed for use as a flying radio laboratory and broadcasting studio, has been acquired by the Pilot Radio and Tube Corporation, radio parts manufacturers, of Brooklyn, N. Y. The cabin, which accommodates six passengers, is being fitted with experimental apparatus for the development of radio altimeters and aircraft radio equipment in general, and also with a powerful transmitter for aerial broadcasting. One of the features of the plane is its roof of transparent perylin, which increases the visibility range for observation, refueling and photographic purposes.

The new craft, a Stinson monoplane powered with a Wright J-6 engine, replaces a smaller ship of the same make which has been maintained by the Pilot company for the past year and a half.

Kolster-Earl Deal Off

The Kolster-Earl consolidation deal has been declared off. A public statement by the Spreckels interests indicates that the Kolster organization withdrew from the negotiations.

Course For Servicemen

H. M. Leight, service manager, Williams Hardware Company, Crosley and Amrad distributors, Streator, Ill., has prepared a course for dealers and servicemen. The course has been in operation for four years.



This picture shows the managers of Grebe's sales campaign in conference. From left to right they are: D. A. Betts, from New England territory; Major H. P. Disbecker of New York; George Rhodes, sales promotion manager; E. S. Hilber, from Middle West; A. W. Milleisen, Pennsylvania representative; and Ralph S. Viall, Chicago and Mid West manager.



This modern plant located at Emporium, Pa., is the latest addition to the Sylvania Factories.

R.C.A. Earns \$1.47

A statement of operations of R.C.A. and subsidiaries for the quarter ending September 30th, 1929, shows a net income of \$13,725,876 for the nine months ending September 30th. Comparisons with earnings for 1928 cannot be made because 1929 earnings include operations of the Victor Talking Machine Division. The data follow:

GROSS INCOME from Sales, Communications, Real Estate Operations, and other Income	\$63,272,926.28
DEDUCT: General Operating and Administrative Expenses, Depreciation, Cost of Sales, Patent Amortization, Estimated Federal Income Tax and Accrued Reserve for Year-End Adjustments	54,543,536.67
SURPLUS PROFITS (for quarter ended September 30, 1929)	8,729,389.61
SURPLUS PROFITS (for 9 months ended September 30, 1929)	13,725,876.72

Experimenters Guild Formed

The Radio International Guild has been founded by the Pilot Radio & Tube Corporation, of Brooklyn, N. Y. Membership is of two classes: one for active members, including radio engineers, experimenters, custom set-builders, and the radio public; the other, trade members, including dealers and merchants engaged in the radio business.

The announced aims of the Guild are to encourage individual experiment in radio to the end that new devices may issue from the home laboratory and attic workshop. Prizes will be offered by the Guild for work of this character. The Guild will provide a source to which members may bring new developments of their own invention and receive the advice of competent engineers.

Dues for active members are 50¢ a year; for trade members, \$1. *Radio Design* is the official organ, published quarterly. Offices are at 325 Berry St., Brooklyn, New York.

New Atlas Officers

Atlas Stores Corporation, the new radio-phonograph combination, operates sixty-one stores located in the following cities: New York, Newark, Chicago, Detroit, Cleveland, Cincinnati, and Akron. In addition the company operates a mail order house in New York. In New York the stores operated by the merger include those of Davega, Fannill, City Radio, and Abe Cohen Exchange.

H. M. Stein, of City Radio Stores, Inc., has been elected president of Atlas Stores; N. L. Cohn, chairman of the board of directors; A. Davega, vice president in charge of retail sales and advertising; Henry Benjamin, vice president and merchandise manager; Michael Cohen, vice president in charge of real estate and construction; and L. Cohn, vice president. O. D. Williams, of Davega, Inc., will continue his duties in the merchandise and advertising departments for the entire chain.

New Plant for Crowley

Henry L. Crowley & Company, manufacturers of Crolite, an insulating material widely employed in the radio and electrical field, announces the purchase of a new plant located at 1 Central Ave., West Orange, N. J. The old plant in East Orange is being dismantled, and the new one will be in operation by December 1, 1929, according to Henry L. Crowley, president of the company. There are 32,000 square feet of space at the West Orange factory, which will accommodate the offices, laboratory, shipping department, and production plant proper, all under one roof.

New Name for Federated

The Federated Radio Trade Association has changed its name to the National Federation of Radio Associations. The new name, it is said, more closely identifies the organization as a national group of local, state, and territorial radio associations. Plans are now under way, according to Michael Ert, president, for examination and registration of radio servicemen in every locality, and, when in final operation, this will increase the supply of adequately trained and competent servicemen.

Sprague Has New Factory

The Sprague Specialties Company, formerly located in Quincy, Mass., makers of high-voltage condensers, has purchased a factory in North Adams, Mass. Officers of the company are Robert C. Sprague, president and treasurer, Frank D. Sprague, plant engineer, and Julian K. Sprague, vice president and production manager.

Distributor Franchises Desired

This will be a regular feature of RADIO BROADCAST in which manufacturers can be kept in touch with reputable concerns who desire a jobber or dealer franchise.

Inquiry D-1

Gentlemen:

We are in the market for territory as distributors of a popular-priced screen-grid radio receiver. We wish to secure radio wholesaling for exclusive territory from a radio manufacturing concern which is not represented in our territory.

Please give us the addresses of such radio manufacturing concerns.

Very truly yours,
G. M. Co.,
Vermilion, S. D.

New Members of P.R.T.A.

Sixty-four new members have joined the Pacific Radio Trade Association since January, 1929. On September 30th, the membership totalled 165, including 15 manufacturers, 21 jobbers, 17 manufacturers' agents, 69 retailers and 43 individuals.

(Continued on page 178)

**Today's Radio Demand
Thoroughly Trained Service Men and Reliable Testing Equipment . . .**

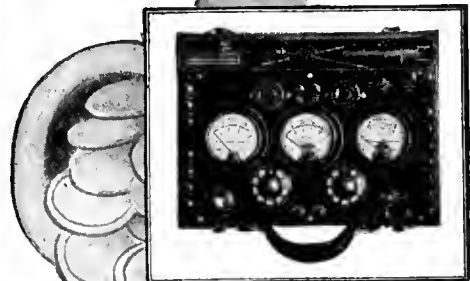

SET MAINTENANCE ASSURED
SERVICE PRESTIGE
DEALER PROFITS
CONSUMER SATISFACTION

WESTON Model 547 Set Tester meets every requirement of radio's demands. Its use is proof of conscientious servicing and high professional

standing, assuring manufacturer and dealer of prime set performance wherever it is periodically employed.

With the Model 547, the operator can quickly and positively check up any receiver made—locate and correct troubles without loss of time and add materially to his profits.

It is a triumph of constructional perfection and electrical completeness—a marvel of simplicity, its operation can be quickly mastered. Enclosed in a durable, abrasion-proof case of black bakelite with all external fittings of the same material, it offers a handsome appearance which will retain its newness in spite of hard usage.

A unique instruction book including individual data for most receivers on the market accompanies each outfit. Before purchasing any testing equipment carefully investigate the unusual merits of this tester. A fair and impartial comparison will convince you of its superior qualifications for service. Write for *free copy* of "Testing Instructions for Service Men."

WESTON ELECTRICAL INSTRUMENT CORPORATION

604 Frelinghuysen Avenue Newark, N. J.



(Continued from page 177)

Financial Notes

CROSLY: A letter dated November 8 to stockholders from Powell Crosley, stated that from January to November 1, 1929, sales were \$13,509,188.08. Sales for the corresponding period in 1928 were \$11,409,430.78. Mr. Crosley has disposed of none of his stock and has recently been a heavy buyer of more. "I am," he says, "devoting my entire attention to the development of the business. I believe firmly in its future."

STEINITE: October sales were \$1,024,977. This is 62.5 per cent. above a year ago.

U. S. RADIO AND TELEVISION: This company earned \$3.01 per share in two months to September 30th.

POLYMET: The earnings of this company were \$2.02 per share for the first quarter on 180,000 shares capital stock outstanding. This compares with 50¢ per share for the same period last year.

TEMPLE CORPORATION: August shipments totalled \$712,836 against \$102,200 for the same period a year ago.

UNITED STATES RADIO AND TELEVISION: September sales were about \$1,500,000. Production beginning about October 1 totalled approximately 2000 sets daily.

POLYMET MANUFACTURING COMPANY: September sales were \$583,793 against \$96,157 for the same period a year ago.

UNITED REPRODUCERS: This company reported a net loss of \$477,990 in the five months ending September 30.

STEINITE RADIO: Earnings of this company were \$1.29 a share in the ten months ending July 31st.

AMRAD CORPORATION: Earnings of \$4.30 a share in the nine months ending September 30, in comparison with 82¢ a share for the same period a year ago, have been reported.

Production Figures

KOLSTER-BRANDES, LTD.: The English branch of the Kolster Radio Corporation has increased its daily set production by more than two-hundred per cent. over last year's figures. By the end of January it is expected that a combination phonograph-radio set will be added to the English line. At the present time Kolster-Brandes dealers in England number about 3500. The company is sponsoring a weekly broadcast feature over the Hilversum station at Holland and a two-hour program on alternate Sundays over the station at Toulouse, France.

TEMPLE CORPORATION: This company shipped \$1,100,000 worth of receivers between October 1st and 31st, making October the most successful month in the history of the company. Daily production is 1000 sets.

GRIGSBY-GRUNOW COMPANY: Plans have been announced for the construction of additional factory space to make possible a 50 per cent. increase in the production of Majestic products. The new factory is to be ready about April 1, 1930. It is to be built on some 34 acres of land in the vicinity of Chicago which the company recently acquired. Also a three-story addition will be constructed at the Armitage Ave. factory.

NATIONAL UNION RADIO TUBE CORPORATION: This company is producing 35,000 tubes a day and is planning to produce 100,000 tubes a day, according to President Chirelstein.

CROSLY: Cincinnati facilities enable production of 8000 radio sets per day. They include 222,000 additional square feet of floor space. Six floors are utilized for set manufacture.

ELECTRAD: Arthur Moss, president, announces the signing of a lease for additional manufacturing space at their present location, 173 Varick Street, New York. Electrad will introduce a new type of volume control as well as a full line of amplifiers.



L. G. Pacent, Pacent Elec.



F. J. Kahn, Kolster

Distributors Appointed

GULBRANSEN: The appointment of the following wholesale distributors has been announced by the Radio Division of Gulbransen: O. M. C. Supply Company, Pittsburgh, Pa.; Elliot & Waddington, New Castle, Pa.; Smith & Phillips Music Co., East Liverpool, Ohio; Greer & Laing, Wheeling, West Virginia; Ohio Battery & Ignition Company, Canton, Ohio; Geo. Byers Sons, Inc., Columbus, Ohio; Rich Electric Sales, Inc., Cleveland, Ohio.

BALKEIT: Balkeit Radio Sales Company have opened offices at 274 Chronicle Bldg., San Francisco. Arthur C. Maryon is manager.

CROSLY: Seven additional branches for the distribution of Crosley products have been established. The Consolidated Automotive Company, Jacksonville, Fla., have opened branches at West Palm Beach and Orlando. A new branch at 315 South Boston St., Tulsa, Oklahoma, has been established by the Ahrens Supply Company of Oklahoma City. The Fargo Motor Supply, Inc., Fargo, N. D., opened a branch at 137 E. Third St., Grand Forks, N. D. R. M. Peffer Co., Harrisburg, Pa., established a distributing point at Altoona, Pa. The Standard Battery & Electric Co. have added a fourth branch at Mason City, Iowa. The Davidson Radio Corporation established a distributing point at South Bend, Ind.

GULBRANSEN: The Alabama Electric Supply Company, Birmingham, Alabama, has been appointed state distributors for the Gulbransen radio.

EMSON: The appointment to an Edison distributorship of the Sprague Electrical Supply Co., Waterbury, Connecticut, was announced recently. The main office of the Sprague company is located

at Waterbury and a branch maintained at Bridgeport. A field force of seven salesmen operate from these two offices. The officials of the company are: president, Starbuck Sprague; treasurer, B. S. Coe; asst. treasurer, H. A. Ashley; secretary, Walter W. Lowell.

STROMBERG-CARLSON: Thirteen retail outlets of the Atlas Radio Stores in Chicago, and thirteen associated stores in Detroit, Cleveland, and Cincinnati, are to handle the Stromberg-Carlson line. Each of the stores has been awarded a Stromberg-Carlson franchise.

PERRYMAN: Nine new distributors for the Perryman Electric Company have been announced: The Alliance Motor Corporation of Rochester, N. Y., with offices in Buffalo, Syracuse, Rochester, and Binghamton, will cover upper New York State. The New England Distributing Co., of Boston, Mass., with offices in Boston, Portland, Springfield, and Worcester will take care of Northern New England.

Weinberg and Co., Chicago, will serve the metropolitan district of this City.

The Atlanta Sales Co., with offices in Atlanta, Ga., and North and South Carolina, will serve dealers in that territory.

Walter Ashe Co., and the Lauce Electric Co., both located in St. Louis, Mo., will serve dealers there.

The Belmont Corp., Minneapolis, Minn., will cover the central part of the State, while the Hanson Duluth Co., of Duluth, will take care of the North-east section of Minnesota.

The Atlas Player Roll Co., with headquarters in Newark, N. J., will serve the dealers in New Jersey, Philadelphia, and sections of Boston, where they have offices.

A Voltage Multiplier

The Super Akra-Ohm wire-wound Resistor is especially adapted for use as a Voltage Multiplier as shown in the above diagram. It is carefully designed to insure an accuracy of 1% and a constant permanency of calibration. Its use is also highly recommended for Laboratory Standards, High Voltage Regulators, Telephone Equipment, and Television Amplifiers and Grid and Plate Resistors, etc.

BULLETIN 62

contains the first complete chart for the use of accurate resistors with microammeters and milliammeters. If you will send us the name of your dealer or jobber, we will send you a free copy.

Shalross Mfg. Company
ELECTRICAL SPECIALTIES
700 PARKER AVENUE
Collingdale, Pa.

TRUVOLT
The SAFE Resistance FOR B-ELIMINATORS

QUICK sales and increased profits when you feature TRUVOLT All-Wire Resistances—satisfied customers, too, who appreciate PERFORMANCE.

TRUVOLT Variable (illustrated) simplifies eliminator construction. Lasts longer due to endwise travel of contact over wire. 22 stock sizes, \$2.50

TRUVOLT Fixed has convenient sliding clip for quick adjustment to desired values. All usual sizes.

175 Varick St., New York N. Y.
ELECTRAD
INC.

ELECTRAD, INC., Dept. RB1
175 Varick Street, New York, N. Y.
Please send full information and prices of TRUVOLTS.

Name
Address

Recently Issued Patents

Method and Apparatus for Testing Networks. Harry Nyquist, Milburu, N. J., assignor to American Telephone and Telegraph Company. Filed February 25, 1928. No. 1,732,311.

Method and Apparatus for Purifying and Charging a Gas into Vacuum Tubes or Other Containers. Ralph W. Lohman, Los Angeles, California. Filed November 1, 1926. No. 1,732,336.

Radio Installation for Moving Vehicles. Herbert Walters and Roman A. Hoerman, Detroit, Michigan. Filed December 5, 1928. No. 1,732,451.

Sound-Reproducing Apparatus. William Brower, Palo Alto, Calif., assignor to Federal Telegraph Company, San Francisco, Calif. Filed May 27, 1926. No. 1,732,495.

Telephonic Loud Speaker. Clair L. Farrand, Forest Hills, N. Y., assignor to Farrand Inductor Corporation, Jersey City, N. J. Filed July 9, 1928. No. 1,732,644.

Superheterodyne Signaling System. Arthur Edwin Leigh Scaues, Strathfield, England, assignor to Associated Electrical Industries, Ltd., Filed May 4, 1925, and in England May 28, 1924. No. 1,732,698.

Wireless Receiving System. Max C. Batsel, Wilkesburg, Pa., assignor to Westinghouse Electric and Manufacturing Company. Filed September 20, 1923. No. 1,732,710.

Directive Reception Microphone. Charles W. Horn, Swissvale, Pa., assignor to Westinghouse Electric and Manufacturing Company. Filed January 2, 1924. No. 1,732,732.

Duplex Radio Transmission System. Frank Conrad, Pittsburgh, Pa., assignor to Westinghouse Electric and Manufacturing Company. Filed May 4, 1925. No. 1,732,741.

Photographic Sound Recording. Vladimir K. Zworykin, Swissvale, Pa., assignor to Westinghouse Electric and Manufacturing Co. Filed May 26, 1927. No. 1,732,874.

Transformer and Coil System. Lester L. Jones, Oradell, N. J. Filed June 1, 1927. Renewed September 10, 1929. No. 1,732,937.

Sound-Reproducing Device. George Hibasco, Schenectady, N. Y., assignor to General Electric Company. Filed January 25, 1924. No. 1,733,013.

Electrostatic Phonograph Pick-up. Humfrey Andrews, Highgate, London, England, assignor to Radio Patents Corporation, Bronx Boulevard, New York, N. Y. Filed April 6, 1928, and in Great Britain July 22, 1927. No. 1,732,393.

Multiplying Graphophone. Henry A. Koester, Norwalk, Ohio, assignor of two-fifths to Oscar D. Miller, Mussillon, Ohio. Filed June 14, 1921. No. 1,732,756.

Sound System. Harry Harold Thompson, Kansas City, Mo., assignor to Radio Corporation of America, N. Y. C. Filed March 15, 1922. No. 1,735,095.

Support For Thermionic Tubes. Arthur Schmidt, Berlin, Germany, assignor to Gesellschaft für Drahtlose Telegraphie m.b.H., Berlin, Germany. Filed November 22, 1924, and in Germany, November 27, 1923.

Means For Energizing Radio Apparatus. Cornelis Bol and Cornelis Hendrik Morel, Eindhoven,

Netherlands, assignors to Radio Corporation of America. Filed Sept. 7, 1928, and in the Netherlands Sept. 3, 1927. No. 1,735,152.

Apparatus for Amplifying Low-Frequency Speech Currents of Radio Receivers. Gustav Eichhorn, Zurich, Switzerland. Filed Jan. 6, 1927, and in Switzerland Sept. 11, 1926. No. 1,735,267.

Television Apparatus. Samuel Thomas Syphrit, Racine, Wisconsin, assignor to A. J. Carter, Chicago, Ill. Filed September 14, 1928. No. 1,735,553.

Low-Frequency Electric Amplifier Circuits. Philip H. Greeley, Washington, D. C. No. 1,735,750.

High-Frequency Oscillation Generator. Albert H. Taylor, Washington, D. C., assignor to Wired Radio, Inc., New York, N. Y. Filed December 22, 1928. No. 1,735,808.

Method of and Apparatus for Reducing Width of Transmission Bands. Allen Carpe, New York, N. Y., assignor to American Telephone and Telegraph Company. Filed August 12, 1926. No. 1,735,037.

Frequency Equalization Carrier System. Estill I. Green, East Orange, N. J., assignor to American Telephone and Telegraph Co. Filed October 22, 1927. No. 1,735,044.



D. E. Replogle, Jenkins Television.

Method of and Apparatus for Reducing Width of Transmission Bands. Allen Carpe, New York, N. Y., assignor to American Telephone and Telegraph Company. Filed August 12, 1926. No. 1,735,037.

Frequency Equalization Carrier System. Estill I. Green, East Orange, N. J., assignor to American Telephone and Telegraph Co. Filed October 22, 1927. No. 1,735,044.

Adjudicated Patents

- (D. C. Del.) Lowell & Dunmore patent, No. 1,455,141, for radio receiving apparatus, claims 3 and 4 held valid and infringed. Dubilier Condenser Corporation vs. Radio Corporation of America, 34 F. (2d) 450.
- (D. C. Del.) Dunmore & Lowell patent No. 1,606,212, for power amplifier, claims 204 and 6 held not infringed. Dubilier Condenser Corporation vs. Radio Corporation of America, 34 F. (2d) 450.
- (D. C. Del.) Dunmore patent, No. 1,635,117, for signal-receiving system, claim 9 held valid and infringed. Dubilier Condenser Corporation vs. Radio Corporation of America, 34 F. (2d) 450.

Patent Suits

- No. 1,158,123. R. A. Fessenden, Apparatus for generating and receiving electromagnetic waves. D. C., N. D. Ohio, (E. Div.), Doc. 2693, Radio Corporation of America et al. vs. The Sparks-Withington Co., Discontinued without prejudice Sept. 19, 1929.
- 1,333,298. Evershed & Kilroy, Sound emitter, filed June 25, 1929. D. C., E. D. Pa., Doc. 5245, Farrand Inductor Corp. vs. The R. Wurlitzer Co.
- 1,403,475. H. D. Arnold, Vacuum-tube circuit, D. C., N. D. Ohio (W. Div.), Doc. E 999, Western Electric Co., Inc., et al. vs. Silverphone Corp. Decree pro confesso (notice Sept. 20, 1929).
- 1,648,808. L. A. Hazeltine, Wave Signaling system, filed Aug. 19, 1929. D. C., E. D. Pa., Doc. 5359, Hazeltine Corp. vs. Atwater Kent Mfg. Co.
- 1,707,544. A. L. Thurax, Electrodynamical device; 1,707,545. E. C. Wente, Acoustic Device, D. C., N. D., Ohio (E. Div.) Doc. E 982, Western Electric Co., Inc., vs. Silverphone Corp. Consent decree for plaintiff (notice Sept. 5, 1929)



F. N. Rauland, Rauland Corp.

A PRODUCTION TESTING SYSTEM

(Continued from page 153)

The prod is next inserted in terminal No. 2 which connects a direct-reading "megger" in the circuit to indicate the insulation resistance of the condenser at the same potential as the breakdown test. The third position discharges the condenser through a resistor and neon lamp, the latter serving to show that contact is made to the discharging terminal. Various switching arrangements have been experimented with, but none as satisfactory as the above have been discovered. The high potential for this test is obtained from a motor generator, as ordinary B supply systems have not proved sufficiently steady for satisfactory "megger" readings.

After passing the test described above the condensers are conveyed to the operator who makes capacitance test. In this test each condenser is placed in a series circuit, the capacity of the condenser regulating the current flow through the milliammeter as shown in Fig. 5. We have found that two values of meters, 0-20 mA. and 0-100 mA. will accommodate values from 0.1 mfd. to 10 mfd. For accurate results with this fixture it is only

necessary to calibrate the meter in terms of capacity and then see that the 110-volt 60-cycle supply is kept constant.

A percentage of the condenser production is also given a life test. However, such tests do not come under the heading of this article and so descriptions of them are not included. [Mr. Callanan's next article will include a description of tests conducted on power transformers, audio-frequency input and output transformers, and a.f. chokes.—The Editor.]

ANSWERS TO PROBLEMS

The following are answers to the six problems which are given at the end of "Engineering Review Sheet" No. 27 on page 147 of this issue:

- (1) 2000 ohms; 760 milliwatts; 39 volts; 39 volts.
- (2) 680 milliwatts; 26 volts; 52 volts.
- (3) 100 ohms.
- (4) 245 milliamperes.
- (5) 16.7 per cent.
- (6) 2.25.

KOLSTER



MODEL K-45

... another leader
who standardizes

on DURHAM RESISTORS and POWEROHMS

KOLSTER!—another great name in radio—another leader who has set the pace in quality receivers for many years—another leader who has long recognized the superiority of the metallized principle upon which DURHAM Resistors and Powerohms are manufactured. Yes, KOLSTER is another who standardizes on DURHAM resistance units . . . because they are absolutely unflinching in accuracy and uniformity. DURHAMS may cost slightly more than average resistances, but their aid to quality reception is well worth the slight difference in price. Furthermore, their presence in a receiver is a guide to the quality of other parts.

Write for engineering data sheets, samples for testing and complete literature. Please state ratings in which you are interested.

Metallized



DURHAM Metallized RESISTORS and POWEROHMS are available for every practical resistance purpose in radio and television circuits, 500 to 200,000 ohms in power types; 1 to 100 Megohms in resistor types; ratings for all limited power requirements; standard, pigtail, or special tips.

THE LEADERS STANDARDIZE ON

DURHAM METALLIZED RESISTORS & POWEROHMS

INTERNATIONAL RESISTANCE CO.
2006 Chestnut Street, Philadelphia, Pa.

IN THE RADIO MARKETPLACE

News, Useful Data, and Information on the Offerings of the Manufacturer

Crosley Model 82-S

CROSLY RADIO CORPORATION: This is a seven-tube receiver using three 224-type screen-grid tubes, one 227-type biased power detector, one 227-type first-stage a.f. amplifier, and two

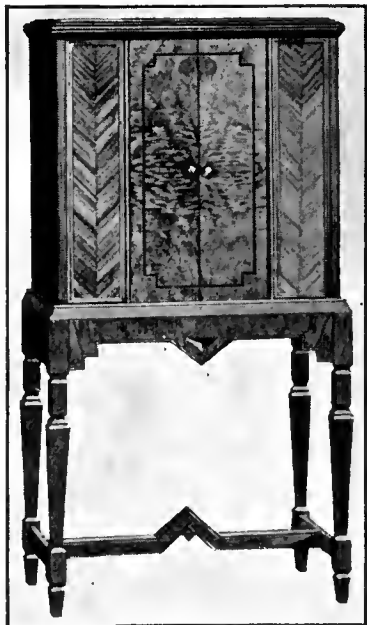

245-type power output tubes. The rectifier is a 280-type tube. Price: \$160.00.

Sound-On-Film Apparatus

RADIO RECEPTOR COMPANY: A special Powerizer power unit has been designed to eliminate the storage battery previously required with all sound-on-film apparatus to supply current for the exciter lamp as well as some of the amplifier tubes. The new Powerizer unit supplies this current as well as B voltage for the amplifier tubes from the light socket. A special voltage compensator is included in the device to compensate within less than 0.1 per cent. line voltage fluctuations between 100 and 130 volts.

Stromberg-Carlson No. 612

STROMBERG-CARLSON TELEPHONE MANUFACTURING COMPANY: This screen-grid receiver has been designed to have a high and uniform gain over the entire broadcast band. The de-



tor is of the power type with automatic grid bias. The bias adjusts itself automatically to the proper value for the strength of signal received. The receiver has three control knobs, the single station selector, the volume control knob, and an on-off switch. As in all Stromberg-Carlson receivers, provision is made for the use of a phonograph pick-up unit. Price, \$259.00.

Fada Models 35 B and 35 C

F. A. D. ANDREA, INC.: The 35B (same cabinet as model 35) uses three 224-type screen-grid tubes in a three-stage tuned-radio-frequency amplifier, two 227-type heater tubes in power detector, an a.f. stage with two 245-type power tubes in push pull, and one 281-type rectifier. Special features of this set are the hum adjuster to reduce hum to a minimum and adjustable sensitivity and selectivity to meet varying installation conditions and requirements. Price: \$225.00.

The 35C (same cabinet as model 35) chassis is the same as present Fada 25. It uses four 227-type heater tubes, one 224-type screen-grid tube, and two 245-type tubes. The 245-type tubes are used in push pull. Price, \$220.00.

Gulbransen Receivers

GULBRANSEN COMPANY: Features of these receivers are: uniform amplification, push-pull output circuit, screen-grid r.f. amplifier and power detector, large diameter electrodynamic



loud speaker, local-distance switch, and complete shielding. The highboy console is priced at \$149.50 and the lowboy at \$139.50.

Balkeitt Model C Radio

BALKEITT RADIO COMPANY: Five tuned stages and special features of design are to be found in this nine-tube neodyne-type receiver. The Model C is a console and is priced at \$175.00.

Kolster Model K-43

KOLSTER RADIO CORPORATION: The K-43 receiver uses screen-grid tubes, an "equipoised" electrodynamic loud speaker, a selector tuner, and push-pull amplification. Price less tubes: \$175.00.

Electric Phonograph Motor

STEVENS MANUFACTURING CORPORATION: The Stevens-Sibley electric phonograph motor has no gears or springs. The drive is against the outer rim of the turntable. It has a speed adjustment giving all speeds required for correct reproduction. There are no exposed parts, all elements being enclosed in a substantial metal housing which is dust and moisture proof. The motor requires no attention, not even lubrication.

Sonora Model A-31

SONORA PHONOGRAPH COMPANY, INC.: The Model A-31 Lowboy is a screen-grid receiver using three screen-grid tubes in the r.f. stages, a power detector, and a push-pull power ampli-



fier. The cabinet, which is of modified Gothic design, is paneled with lacewood and American walnut. Price: \$149.50.

Zenith Model 54

ZENITH RADIO CORPORATION: This is a new nine-tube radio receiver with automatic tuning and two stages of push-pull a.f. amplification. It is loop operated and is priced at \$370.00. Other Zenith receivers range in price from \$175 to \$700.00.

Freed Radio Model 90

FREED-EISEMANN RADIO CORPORATION: The Model 90 receiver utilizes a number of interesting features among which are automatic tuning, the use of a variometer in connection with the first tuned circuit to permit accurate tuning, and the use of four screen-grid tubes, three as r.f. amplifiers and one as a detector. Up to as many as ten stations can be tuned-in with the



automatic tuning device by sliding along the indicator arm to the desired station and then pulling out the knob.

The Per-Con Ground

RICHMOND METAL PRODUCTS COMPANY: This company has designed a special ground in the form of a hollow steel tube made in three sections and containing special materials.

New Bosch Receiver

AMERICAN BOSCH MAGNETO CORPORATION: The Console Model 16 is one of the newest

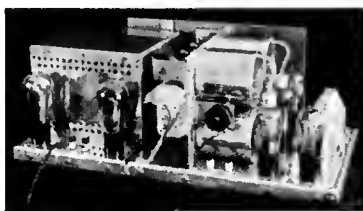

Ware Band Selector

WARE MANUFACTURING COMPANY: The Ware receiver uses the band selector circuits developed by Vreeland. In the r.f. amplifier are two screen-grid tubes. A unique switching arrangement is used to give four different operating characteristics, i.e., broad tuning, sharp tuning, sensitive (for distant reception), and insensitive (for local reception). This chassis is incorporated in a table model at \$195.00 and in various consoles ranging from \$280.00 to \$800.00 in price.

Thordarson Power Amplifier

THORDARSON ELECTRIC MFG. CO.: A new completely self contained power amplifier has been designed by this company. It has a maximum undistorted power output of 4650 milliwatts, a voltage amplification of 275, and is designed so that the hum has been reduced to a minimum. The amplifier is guaranteed for 90 days. Price \$89.50.

Bush & Lane Model 90

BUSH AND LANE PIANO COMPANY: The Model 90 houses a chassis using screen-grid tubes followed by a detector and two-stage u.f. amplifier. All grid, plate, and filament voltages,

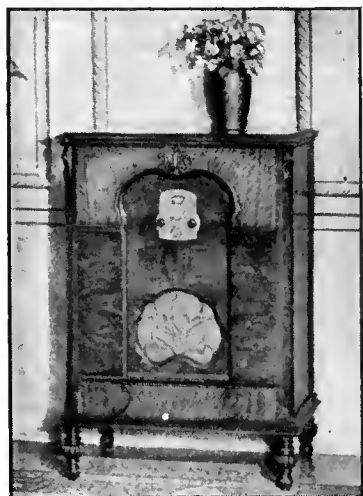

and also field current to operate the electrodynamic loud speaker, are supplied by the socket-power unit. An optional chassis using 227-type tubes as the r.f. amplifiers may be installed in place of the screen-grid chassis. Price: \$217.50. Other models are priced as follows: Table Model 20, \$125.00; Model 21, \$160.50; Model 31, \$187.50; Model 40, \$179.50; Model 50, \$197.50; Model 60, \$199.50; Model 70, \$207.50.

Columbia Model 920

COLUMBIA PHONOGRAPH COMPANY: The Model 920 is a modern electric phonograph. The record bin contains space for 50 records. The turntable is electrically operated from an in-



duction motor. A Columbia pick-up unit is used and the a.f. amplifier employs two 245-type tubes in push pull in its output. Price: \$197.00.



Bosch receivers using the Bosch screen-grid chassis. Price complete with Bosch electrodynamic loud speaker: \$198.50.

Two New Kits

PILOT RADIO AND TUBE CORPORATION: The Pilot kit K-113 contains all the parts necessary for the construction of an a.f. amplifier using two 245-type tubes in push pull. The kit includes an aluminum base already drilled for the transformers, sockets, resistors, etc., and a completely assembled and wired power pack. All the amplifying unit must be wired together.

The K-117 contains the necessary parts for the Pilot Twin Screen-Grid Eight. It uses three stages of screen-grid r.f. amplification, shielded coils, screen-grid detector, a push-pull a.f. amplifier, and a built-in power supply.

Portable Phonographs

Q. R. S.-DEVRY CORPORATION: The portable electric phonograph style 375 is operated with a specialty constructed electric motor powered from three 1½-volt dry-cell batteries. In ordinary use the dry-cell batteries will have a life of about six months. Space is provided for carrying several ten- and twelve-inch records. Weight 24½ pounds. Price: \$37.50.

The style 50 Deluxe model uses the same mechanical and electrical equipment as the style 375. It is housed to a somewhat more expensive case. Weight 27 pounds. Price \$50.

THE RADIO DEALER'S DIRECTORY OF RECENT PRICE CHANGES

Company	Model No.	Former Price	New Price	Company	Model No.	Former Price	New Price	
All-American Mohawk Corp.	97 (New)		\$225.00	Atwater Kent Mfg. Co.	524	\$295.00	\$225.00	
	98 (New)		235.00		526	260.00	185.00	
	99 (New)		245.00		528	305.00	235.00	
94-6 (New)		105.00						
F. A. D. Andrea, Inc.	35-R (New)		255.00	The Brandes Corp.	B-15	125.50	97.50	
	35-C (New)		220.00		B-16	165.00	136.00	
Colonial Radio Corp.	32 AC Cavalier	\$235.00	175.00		Pioneer Radio Corp.	100 chassis (New)		83.00
	32 AC Piccadilly	235.00	175.00			101 Lowboy		116.00
	32 AC Moderne	270.00	235.00			102 Highboy		136.00
	32 DC Cavalier (New)		175.00			Radio-Victor Corp. of America	44	110.00
	32 DC Piccadilly (New)		175.00		46		179.00	130.00
	32 DC Moderne (New)		235.00		60		130.00	98.00
Crosley Radio Corp.	31-S	67.00	56.50		Bremer-Tully Mfg. Co.	164		\$124.00
	33-S	115.00	112.00			195		149.00
	34-S	125.00	116.00	134			164.00	
	41-S	85.00	65.85	159			195.00	
	42-S	140.00	126.00	Stromberg-Carlson Tel. Mfg. Co.	642	\$247.50	\$259.00	
A-C Dayton Co.	AC-9961 (New)		173.50					
	AC-9971 (New)		193.00					
	AC-99110 (New)		275.00					
Grigsby-Grunow Co.	91	137.50	116.00					
	92	167.50	146.00					
Howard Radio Co.	Florentine (New)		275.00					
	Happlewhite (New)		245.00					
	Highboy (New)		210.00					
	Consolette (New)		185.00					
Kellogg Switchboard & Sup. Co.	523	250.00	175.00					



WE, too, can shout our name from the house-tops. & But — can such shouting be one-half so impressive as this truthful statement, quietly made: "Over 80% of the great radio set manufacturers of the country use



CONDENSERS
TRANSFORMERS
RESISTANCES
CONNECTORS
COILS
PLUGS

POLYMET PRODUCTS"

POLYMET MFG. CORP.
837 E. 134th Street, New York City

Don't Guess at Set Troubles



The Jewell Pattern 199 Set Analyzer locates set troubles instantly also makes every essential radio service test.

You can save time and build profitable business by using a Jewell Pattern 199 to locate set troubles. Pattern 199 is the lowest priced complete set analyzer on the market. Accurate and easy to use. Every service man should have one. Sold by leading radio jobbers.

Mail the coupon for a free copy of the Jewell Instruction and Data Book which contains data on 139 popular sets.



Jewell Electrical Instrument Co.
1642-H Walnut Street, Chicago, Illinois

Please mail Instruction and Data Book also complete information on Pattern 199 Set Analyzer.

Name

Address

No. 310

RADIO BROADCAST Laboratory Information Sheet

January, 1930

Factors Considered in Receiver Design

IN THE DESIGN of a radio receiver certain factors must be considered in order to determine the circuits to be used. Some of these important factors are:

1. The limiting values (maximum and minimum) of the field strength from the transmitting station.
2. The output obtained from the antenna at a given field strength.
3. The power output required from the receiver.
4. The r.f. frequency band to be received.
5. The a.f. frequency band to be amplified.
6. The nature and strength of the interference from other radio transmitters and from noise.
7. The selectivity required to permit the satisfactory reception of the desired signal and the elimination of all undesired signals.
8. The stability of the frequency transmission characteristic and the gain of the receiver.

With these facts decided, it is possible to proceed with the design and to determine how much r.f. and a.f. amplification is required, how selective the r.f. circuits must be, and what type of audio-frequency output circuit must be used to supply power to the loud speaker.

In the design of broadcast receivers the tendency has been toward the building of stable, high-gain r.f. amplifiers that are able to deliver sufficient voltage to the detector for satisfactory output at field strengths in the order of 1 to 10 microvolts per meter. This represents a very high order of sensitivity and it is probable that the average noise level in many locations is of the same order or greater than the above field strengths, thereby making it of no advantage to endeavor to increase further the gain of the r.f. amplifier since this would simply result in an excessive ratio of noise to signal.

No. 311

RADIO BROADCAST Laboratory Information Sheet

January, 1930

Effect of Reflection and Echoes

IN CONTEMPLATING the subject of fidelity in its relation to the problem of loud speaker reproduction there are many factors to be considered. In this connection one of the most important considerations is the condition under which the loud speaker is to be operated, whether it is to be operated in the open, in a large room with heavy drapes, in a room practically bare of furnishings, etc., for it should be realized that the naturalness of the reproduction will depend to a large extent upon these conditions.

When a loud speaker is operated in a room there is a certain amount of reflection of sound from the walls and standing waves are also generated. Both of these factors cause a change in response depending upon the position of the listener in the room. At one point we might hear a very intense sound at some particular frequency but, upon moving but a step or two away, the intensity of the sound will markedly decrease. If the loud speaker is supplied with a single-frequency tone this effect

will be quite noticeable but it is not as effective in producing a definite audible change in intensity when listening to music. In music or speech the frequency changes so rapidly that the effects of standing waves are not especially noticeable, if at all.

From the above remarks it should not be thought that the effects of reflection and echoes are always detrimental. In many cases a certain amount of echo effect improves the reproduction, adding an effective vastness and a richness to the tones which would otherwise be lacking.

It is frequently the case that the naturalness of the reproduction is greater if one listens in some room adjacent to the one in which the loud speaker is located, and if possible it is frequently advisable to locate the loud speaker in some room other than that in which one ordinarily sits when listening to a program. In such a case the increased naturalness is probably due to the effect of the reflection and echoes which occur.

No. 312

RADIO BROADCAST Laboratory Information Sheet

January, 1930

Measurements of Sensitivity

IT IS BECOMING quite common to read statements to the effect that a certain receiver has a sensitivity of so many microvolts per meter. As this method of rating the sensitivity of receivers is becoming so popular, in this "Laboratory Sheet" we indicate exactly what this term means.

When a receiver is to be measured for sensitivity it is generally done in the following manner. A receiver is set up and a resistor is connected across the a.f. output circuit of the set. This resistor has a value such as to give maximum power output per volt on the grid of the power tube. In most cases the resistor will have a value equal to twice the plate resistance of the output tube.

The next step is to apply to an artificial antenna a known r.f. voltage modulated 30 per cent, at 400 cycles and to increase the r.f. input voltage until 50 milliwatts of audio-frequency power is developed across the output resistance. We then determine the magnitude of the input r.f. voltage required to produce this output by dividing by the effective height of the artificial antenna which is usually four meters. This gives us the microvolts per meter input required to produce the standard output of 50 milliwatts.

Assuming that such a method is used in determining the sensitivity of the set, it is simply necessary to give the microvolts per meter input for standard output in order to define completely the sensitivity of the receiver. We can, therefore, say, for example, that a certain set has a sensitivity of 10 microvolts per meter. This means that if a thirty per cent, modulated r.f. signal is impressed across the input, then 50 milliwatts of power will be developed in the output at 400 cycles.

During the past few years there have been remarkable improvements in r.f. amplifier circuits and as a result receiving sets to-day are much more sensitive than past models. Whereas a sensitivity of 50 or 100 microvolts per meter was not uncommon during past seasons, more recent receivers have a much higher sensitivity, in many cases being of the order of 3 or 5 microvolts per meter.

In many sets the sensitivity varies widely over the broadcast band, generally being low at low frequencies and high at high frequencies. This is a disadvantage which is gradually being overcome and sets are being produced which have a more uniform high sensitivity throughout the entire broadcast wave band.

Philippine Radio Stations

E. T. Wilson, of the Radio Corporation of the Philippines, Manila, sends the following information on stations now operating in the Philippine Islands.

- kzrm—Manila, 485 Meter, 1000 Watts
- kixa—49 Meters (also 41.5 and 31.6 Meters), 1000 Watts (transmits same programs as kzrm)
- kzia—Manila, 260 Meters, 15 Watts
- kzac—Cebu, P. I., 320 Meters, 1000 Watts

These are the only broadcasting stations in the Islands.

Jenkins Televisor Displayed

A commercial model of the Jenkins Televisor was shown at the Chicago Radio Show and also at a similar show at Trenton. The cabinet is 18 by 18 by 24 inches. Shadowgraphs are seen through an aperture in the front with the aid of a concealed magnifying lense.

Technidyne Licenses Ajax

The Technidyne Corporation, 644 Broadway, New York, has sold to the Ajax Electrothermic Corporation, Trenton, New Jersey, an exclusive license for the use of Banning patent No. 1,667,715 and Jonas patent No. 1,608,560 covering coil systems for use in high-frequency induction furnaces. Technidyne acquires the exclusive use or license in radio of the Northrup patent No. 1,378,187.

Sonora Has Canadian Factory

The Sonora Corporation of Canada, Ltd. has located a factory in Toronto at 345 Adelaide St., West. The new plant is already in production and W. B. Puckett, formerly treasurer of the American company, has been appointed vice president and general manager of the Canadian branch.

News of the N.F.R.A.

A model serial-number ordinance for consideration of local town councils is available from the officers of the National Federation of Radio Associations. Where serial-number abuses are serious and no state legislation has been passed, the association feels a local ordinance is helpful.

New members of the Radio Wholesalers Association are George H. Wann Company, Boston; Electric Equipment Company, Youngstown, Ohio; and J. V. Kane Company, Philadelphia.

The Traffic Committee of the Radio Wholesalers Association, working with the R.M.A. has effected a freight rate reduction on radio products which will reduce transportation costs \$1,500,000 annually.

A SERVICE DEPARTMENT THAT PAYS

(Continued from page 133)

response to an "S. O. S." from the fellow who has been delayed.

Mr. McCrork attributes much of the success of his department to the fact that all service calls are made on definite appointments—also that, as a consequence, no not-at-home reports are accepted from servicemen.

Shop Work vs. Outside Work

Although the rapid rise of a.c. sets is steadily reducing the number of sets having to be brought into the shop for repairs, it is found advisable to remove approximately 40 per cent. from the homes of the owners. It has been found that the greater facilities available in the shop insure better work in many cases. No estimates are given in any case until the set has been carefully gone over in the shop. It has been found that so many faults can produce

(Continued on page 185)

Important Announcement

**"A New"
Wright-DeCoster Reproducer
—for the Home—**

Now you can equip your radio so that it will have the same tone quality and truthful reproduction as the finest theatrical sound equipment, except in volume.



Model 117 Jr. Table Style

Write for Descriptive Matter and District Sales Office.



Model 117 Jr. Console Style

On account of a flood of requests we have brought out a reproducer with the same features as our theatrical reproducers. It is made especially for the home [or for small halls.

WRIGHT-DECOSTER, INC.
2213 University Ave., St. Paul, Minn.

**TYPE 360
TEST OSCILLATOR**

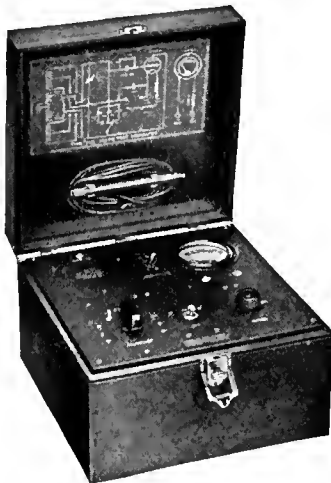

One of the new test oscillators for the radio service laboratory is now ready. It will deliver a modulated radio-frequency voltage at any point in the broadcast band (500 to 1500 kilocycles) and at 175 and 180 kilocycles. The tuning control is calibrated with an accuracy of 2 per cent.

The Type 360 Test Oscillator is intended to be used for neutralizing, ganging, and tuning of the radio-frequency stages in a receiver, and it is fitted with an output voltmeter for indicating the best adjustment. This voltmeter is of the copper-oxide-rectifier type, and by means of a switch it may be connected across a 4000-ohm load or across the dynamic speaker of the receiver when making tests.

Price \$110.00

GENERAL RADIO COMPANY

30 State Street

Cambridge, Massachusetts



Stop A.C. Tube Troubles at the Source

Every A. C. set owner is a prospect for the Vitrohm Unit. It saves A. C. Tubes and insures full tube life. Cuts costly service calls and customer complaints due to tube failure. Send your order today for twelve units packed in three color counter display carton.

WARD LEONARD ELECTRIC CO.
MT. VERNON NEW YORK



Retails for \$2.00

VITROHM 507-109
For sets using 65 watts or less
VITROHM 507-109A
For sets using more than 65 watts and less than 130 watts



John H. Morecroft

Zeh Bouck says:

"MORECROFT is the finest engineering interpretation of Radio's first quarter century we have."

Second Edition—Revised and Enlarged

Principles of Radio Communication

BY JOHN H. MORECROFT

Again Mr. Bouck says: "No radio book has ever been of greater utility to the engineer and student than this classic—the only reliable reference of its kind six years ago and today the most astounding collection of answers to technical questions from the analysis of radio frequency phenomena in terms of complex formulae to why a particular amplifier howls."

\$7.50

JOHN WILEY & SONS, Inc.

440 Fourth Ave., New York

Please send me Morecroft's RADIO COMMUNICATION for free examination. Within ten days after its receipt, I will either return the book or send you \$7.50.

Name.....
Address.....
Firm.....RB 1-30

No. 313

RADIO BROADCAST Laboratory Information Sheet January, 1930

Fidelity in Radio Receivers

RADIO ENGINEERS, in rating the performance of radio receivers, now make use of three terms, sensitivity, selectivity, and fidelity. These three factors completely define the essential characteristics of a set and make it possible to compare readily one set against another.

Sensitivity is determined, as explained in "Sheet" No. 312, by impressing an r.f. voltage on the input of the set, of a value such that normal output—50 milliwatts—is obtained. In this sheet we explain the meaning of the term fidelity and explain briefly how it is measured. "Laboratory Sheet" No. 314 gives similar data on selectivity.

Fidelity is the term used to indicate the accuracy of reproduction, at the output of a radio receiver, of the modulation impressed on the r.f. signal applied to the input of the receiver under test. A receiver having perfect fidelity would be one in which the form of the output current was exactly similar to the form of the current used to modulate the r.f. signal. Fidelity is determined by setting up the receiver to be tested and impressing on its input an r.f. signal modulated at 30 per cent., the input

signal having a value such that normal output is obtained. The frequency of the modulating signal is then varied (the modulation being held constant) over the entire audio-frequency band and the output power at each frequency is noted. From these data a curve can be plotted showing how the audio-frequency output power from the set varies with frequency.

Such curves are run at various radio frequencies—say 600, 1000, and 1500 kc.—in the broadcast band so that the variation in fidelity can be determined. In this way we can tell something regarding the characteristics of the r.f. amplifier system, for if the system tunes too sharply at some point in the broadcast band the sidebands will be suppressed partially and this will show up on the curve which we plot as a falling off in response at the higher audio frequencies.

In making such tests it is essential, of course, that the source of audio-frequency voltage used to modulate the r.f. input signal be quite pure, i.e., free from harmonics. Generally the total harmonic output from the a.f. oscillator should not be allowed to exceed five per cent.

No. 314

RADIO BROADCAST Laboratory Information Sheet January, 1930

Selectivity of Radio Receivers

PRACTICALLY speaking, the selectivity of a receiver is that characteristic which enables us to determine how well the set will tune-out one signal and tune-in another. Technically, it is defined in somewhat similar fashion, as the degree with which a radio receiver is capable of differentiating between signals of different carrier frequencies.

Selectivity is determined with the aid of an r.f. oscillator by means of which we are able to impress known r.f. voltages on the input of the set, note the output of the set, and then to vary gradually the frequency of the r.f. oscillator, at the same time adjusting the voltage supplied to the receiver so as to maintain the same output. In this way we obtain a set of figures showing how the output of the receiver falls off either side of the frequency to which it is tuned. Generally the more rapidly it falls off the better is the selectivity.

Unfortunately a receiver's selectivity is, as has been pointed out many times, closely tied up with its fidelity, for if we make the selectivity too great the sidebands are suppressed and the high frequencies are partially suppressed. At least this is true of ordinary circuits.

Selectivity curves are, of course, made at various points throughout the broadcast band so that the variation in the receiver's selectivity at different points in the broadcast band can be

determined. The results are finally plotted in the form of curves, an example is given below.

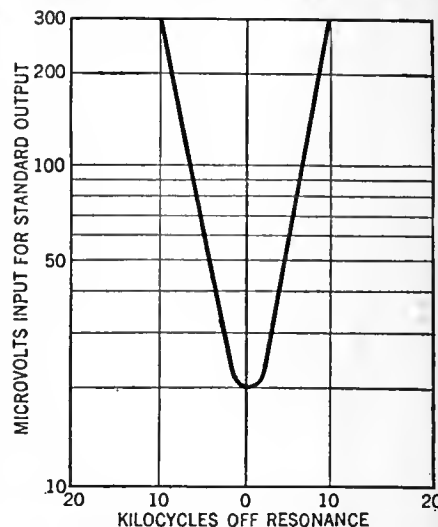

No. 315

RADIO BROADCAST Laboratory Information Sheet January, 1930

C-Bias Resistor Values

THE TABLE on this sheet gives the values of C-bias resistor in ohms which must be used in conjunction with various types of tubes used in a.c. receivers to supply correct bias. It will be noted that the value of the resistor for use when the filament is operated on a.c. is slightly different from the value when the filament is on d.c. This is due to the fact that in the case of d.c. operation the returns are connected to the negative side of the filament and in a.c. operation they are connected to the mid point of the filament side. If the two tubes are connected in parallel, and obtain their C bias from a common resistor, then the value of the C-bias resistor should, of course, be half that indicated in the table.

TYPE OF TUBE	PLATE VOLTAGE	C-BIAS RESISTOR IN OHMS FIL. ON D. C.	C-BIAS RESISTOR IN OHMS FIL. ON A. C.
226	90	1700	1500
	135	1500	1300
	180	1300	1100

TYPE OF TUBE	PLATE VOLTAGE	C-BIAS RESISTOR IN OHMS FIL. ON D. C.	C-BIAS RESISTOR IN OHMS FIL. ON A. C.
227	90	2000	1800
	135	1800	1600
	180	1600	1400
112A	90	850	1300
	135	1300	1650
	180	1350	1600
171A	90	1650	1900
	135	1700	1850
	180	2000	2150
210	250	1500	1800
	350	1700	1950
	425	1750	1950
250	250	1600	1550
	300	1400	1300
	400	1200	1100
245	450	1550	1550
	180	1250	1250
	250	1550	1550
224	180	350	350

(Continued from page 183)

the same unsatisfactory condition in a set that it is never safe to name a price for service work without a thorough examination. After the trouble has been determined the cost is communicated to the customer by telephone. A charge of \$3 is made for inspecting sets where the latter decides not to have the work done.

Mr. McCrork is insistent on thoroughness in service work. He believes that lack of this quality inspired by the inclination of many servicemen to hustle through jobs has been responsible for a great deal of unsatisfactory "service" work.

His men are carefully trained not only to look for the obvious faults but to probe deeply. It is not enough to get a set working. Like a fabled Chinese doctor of old, part of the job of those who work with him is to do everything in their power to insure sets staying in the best of health. Although the obvious fault may be only a burned-out tube, the serviceman does not necessarily stop there. The set is given a detailed examination to determine whether it merely happened or came as the result of some definite mechanical or electrical weakness.

High-Grade Men Employed

Because of this requirement, Mr. McCrork employs only experienced servicemen—men who recognize their responsibility in insuring the best possible entertainment in the "Theater of the Home." His requirements for a serviceman, given in the order of their importance are: ability, courtesy, appearance, and honesty. Care is taken to get men who measure up to these specifications. They are paid straight salaries to further insure that no work will be skimped.

This service manager also prides himself, and justly so, on the fact that almost no sets are returned to the factory. No matter how complicated the work of repair, it can invariably be done in the shop, even though this should entail the winding of an obsolete transformer or the replacing of a condenser block or choke coil that would have to be made up. Naturally, this sometimes adds to the expense of the service department. On the other hand, it permits of the quickest sort of service and that is one of the features Mr. McCrork is stressing in building for the future. Thanks to the skill which makes such work possible, it has been found poor economy to carry a large stock of parts. Only those most frequently needed for the most popular sets are kept on hand. Others are ordered as needed or made in the shop.

In addition to the usual small tools, servicemen are required to have a set-ster (Jewell or Weston). These are supplied to them at cost when they are hired, the price being taken out of their monthly salaries in small amounts. Each man also carries a complete set of carefully tested tubes. This has been found to do away with much unnecessary traveling back and forth from homes to store.

Servicemen Do Not Sell

Incidentally, it is interesting to note that members of the Universal Radio department are not encouraged to do any selling. This is so for the obvious reason that their main work is to build up their department. Any unwarranted effort to sell a new set to a customer who merely wants an old one repaired might be misconstrued by the latter.

How natural it would be for the customer to think: "Oh well, it's this fellow's job to sell me a new set if he can. I'll get someone who doesn't feel that way about it to fix the old one and make it as good as new." Servicemen are only allowed to talk new sets when they are asked point blank by the customer whether or not it would

be to his advantage to make a change. Then they turn such leads over to the sales department.

Only broadcast advertising over station WCAU (which is under the same management) is used in featuring this service. This, plus the word-of-mouth advertising by satisfied customers has been found entirely adequate. With broadcast advertising there is little or no lost circulation, for every radio set owner who listens in is a potential service customer. A radio in need of repairs bringing imperfect reception on an announcement of a well-known radio service supplies plenty of incentive to the owner to go to the phone and call at once. The service department is open from 9 o'clock in the morning until 11 o'clock at night. Thus, to make 24-hour service infinitely more than an idle boast, some servicemen work from 9 A.M. until 6 P. M. while others work from 11 A. M. until the department closes. The greatest number of service calls come in on Fridays and Saturdays. Particular pains are taken to see that the latter are taken care of before Sunday. As a result of the broadcast advertising over WCAU not a few sets are received by express from people who want to avail themselves of the service of which they hear. These outfits are diagnosed and the estimated cost communicated to the owner for approval before the work is done.

Since entering the radio business in 1919, it has been Mr. McCrork's dream to have a service department that would pay for itself over and above the work of installing and servicing the sets sold by the store. Although, admittedly, his present department is not perfect in every respect, it has achieved this end and is progressing rapidly. This winter will undoubtedly find from 20 to 25 servicemen regularly employed in rendering a service that Philadelphians already recognize for its promptness and efficiency.

"The opportunities for the service department are limitless," said this service manager in closing. "Indifferent service has been so much the rule in the past that it would seem only a matter of sound common sense in the conduct of it to make this section of the business highly profitable. I'll repeat: service is *not* a sideline and the success of the fellow who regards it as a serious bread-and-butter business will be limited only by his ingenuity and managerial ability."

ANOTHER ANGLE ON SERVICE

(continued from page 137)

equipment possible and a staff of specialists in each make of car, the repair job is done as it should be done—as well, if not better than, it would be done if the car were sent back to the manufacturer's service shop at the factory.

The regional repair factory charges the dealer for the job; and the dealer charges a small commission for handling the transaction. Thus the factory makes its proper profit, and the dealer makes his. Because of the volume of repair business which the repair factory does, its rates are cheaper than those charged by independent repair garages.

Advantages of Wholesale Servicing

The advantages of the regional factory are almost self-explanatory. The manufacturer has the assurance that his cars are being properly serviced, so that the customer is satisfied. The manufacturer also has a larger market for spare parts, since the regional factories would use only regular or authorized parts. The dealer is relieved of the necessity of stocking a great

(Continued on page 188)

NEW AUDIOS for Old Sets



A profitable business for service stations is the installation of tone quality by replacing inferior units with THORDARSON REPLACEMENT TRANSFORMERS.

The chief difference between this year's sets and last year's, between high priced sets and cheap ones, is the difference in audio amplification. This is the difference which the OWNER HEARS.



R-100 Straight Audio, \$2.25
R-101 Input Push-Pull, 3.50

AT ALL JOBBERS

THORDARSON

THORDARSON ELECTRIC
MFG. CO.

Huron, Kingsbury and Larrabee Streets
CHICAGO, ILLINOIS

Give Your Radio Set a Chance
Install De Forest Audions in your
radio set and you will note the
difference right from the start—
purer tones, more volume and
hum-free reproduction.

DE FOREST RADIO CO.
PASSAIC NEW JERSEY



de Forest
AUDIIONS



No. 316

RADIO BROADCAST Laboratory Information Sheet

January, 1930

Range of Frequencies Required

PAST AND PRESENT improvements in quality of reproduction from radio receivers has been due in no small extent to the important research carried on by the laboratories of the Bell Telephone Company to determine the characteristics of the ear so that some rules might be laid down regarding the range of frequencies required for good reproduction and the range of pressure common in speech and music. A group of curves illustrating some of these important characteristics is given in "Laboratory Sheet" No. 317. These curves show how the sound pressure varies for sounds of constant volume over the entire band of audible frequencies. On the curve are also indicated some contour lines of equal volume which have been divided into three parts, the bass, the tenor or alto, and the soprano, corresponding to the range of notes produced by various instruments.

shows that although the pressure is greater at the low frequencies, the range of pressure is not as great as at the higher frequencies.

The musical instruments producing the greatest pressures are the percussion type such as the traps and drums. Although the fundamental tones produced by these instruments are quite low they are very rich in harmonics extending sometimes up to 10,000 cycles.

Generally speaking, the fundamental and first three overtones are essential in order to distinguish the notes of various instruments and better reproduction is obtained if the fourth overtone is reproduced. The frequencies used most in music are contained in the octaves between 128 to 512 cycles. As the fourth overtone of 512 cycles is 8192, tones of this frequency and below frequently occur in music. The average individual, however, would probably find it difficult to detect the elimination of all frequencies above 6000. The letters "dv" on the curve mean "double vibrations."

The vertical distance between the two limiting lines indicates the range in pressure and

No. 317

RADIO BROADCAST Laboratory Information Sheet

January, 1930

Range of Frequencies Required

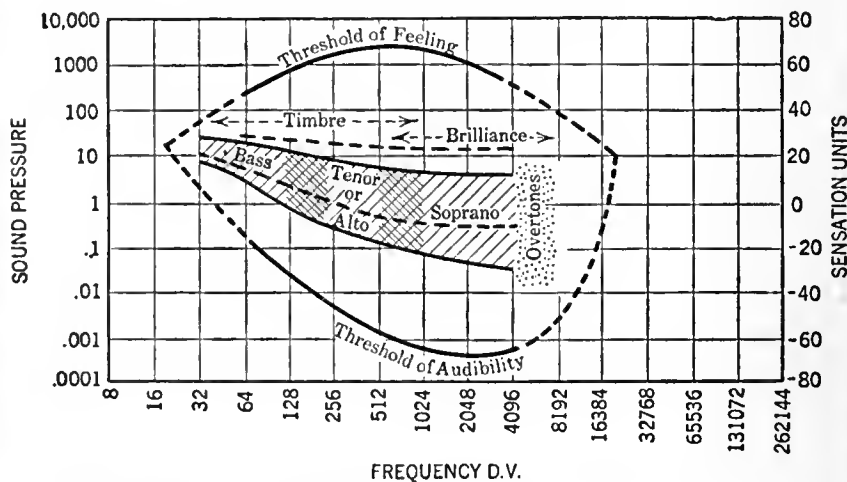

By the author of

"Principles of Radio Communication"

An independently written introduction to the subject of Radio

John H. Morecroft

Elements of Radio Communication

BY JOHN H. MORECROFT

"We can highly recommend 'Elements of Radio Communication' to those of our readers who want a book that will give them a strong, elementary grounding in radio and leave them with few questions to ask save those which may be born of a desire for more knowledge."

Boston Post Radio Section

\$3.00

JOHN WILEY & SONS, Inc.

440 Fourth Ave., New York

Please send me Morecroft's "Elements" for free examination. Within ten days after its receipt I will either return the book or send you \$3.00.

Name.....

Address.....

Firm.....RB 1-30

No. 318

RADIO BROADCAST Laboratory Information Sheet

January, 1930

60- and 120-Cycle Hum Measurements

IN THIS "Laboratory Information Sheet" are given some data on hum measurements made in the Laboratory some time ago. The measurements were made using an a.c.-operated Wright DeCoster electrodynamic loud speaker. These measurements were made to determine how much a.c. voltage at 60 and 120 cycles was necessary across the primary of the coupling transformer in the loud speaker to produce an audible hum output.

Two series of measurements were made. The first to determine what voltage would produce a just audible sound and the second to indicate what voltage was required to produce the maximum hum that might be tolerated. The figures are useful in indicating how much hum voltage in the output circuit of a radio receiver is permissible. It is interesting to note from the figures given below that the ratio of the voltage at 60 cycles to the voltage at 120 cycles is approximately 10, which ratio agrees quite well with the variation in sensitivity of the ear between 120 and 60 cycles.

JUST AUDIBLE HUM	
60 cycles	1.3 volts
120 cycles	0.15 volt
MAXIMUM TOLERABLE HUM	
60 cycles	5.2 volts
120 cycles	0.54 volt

If we assume that most of the hum arises in the detector circuit, it is a simple matter to calculate the maximum permissible value of this hum. We simply have to divide the voltage indicated above by the gain of the amplifier. For example, if an amplifier had a gain of 200, then the amount of 60-cycle voltage in the plate circuit of the detector tube to produce a just audible hum from the loud speaker would have to be 1.3 divided by 200 which gives 0.0065 volt or 6.5 millivolts. The maximum permissible 120-cycle voltage is 0.15 divided by 200 which gives 0.00075 volt or 0.75 millivolts.

READS FILAMENT READS PLATE READS CONTROL
VOLTS HERE VOLTS HERE GRID HERE

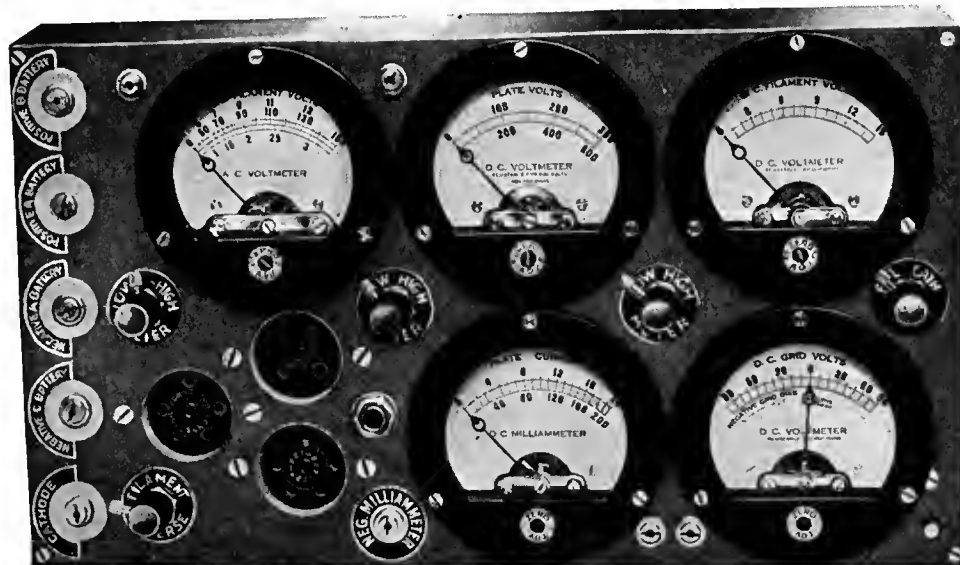

READS PLATE READS SCREEN
CURRENT HERE GRID VOLTS HERE
INDICATES SIMULTANEOUSLY ALL THE ABOVE VALUES

THE NEW Type SG 4600 RADIO SET TESTER

Radio's Most Complete Servicing Equipment

Dealers' net price complete with carrying case \$90.00

Write for FREE Bulletin No. 26

The Hickok Electrical Instrument Company CLEVELAND, OHIO

MEN ARE IN DEMAND In All Branches of Radio



Prepare through a school with a reputation for efficiency. Our courses are easy, interesting and effective.

We have large classrooms, laboratory, workshop, dormitory and many other new and unusual features.

Subjects Taught:

COMMERCIAL RADIO RADIO SERVICE
RADIO BROADCAST VITAPHONE-MOVIE TONE
LABORATORY NAVIGATION
RADIO MATHEMATICS

Mid-Year Semester Begins January 20, 1930
Literature on Request

COMMERCIAL RADIO INSTITUTE
38 W. Biddle St. Founded 1920 BALTIMORE, MD.

Add the Highest Quality of Radio To Your Present Amplifier

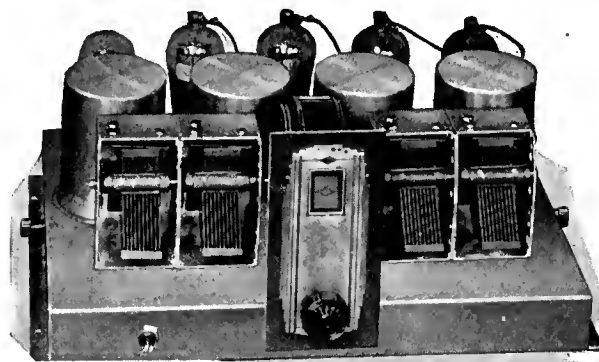

If you wish to add the most modern type of Radio Reception to your—

Electric Phonograph Auditorium Amplifier Public Address System Power Amplifier

the NATIONAL Screen Grid MB-29 Tuner is especially adapted for such use.

Equipped with 4 Screen Grid A. C. tubes, it will give satisfactory reception on indoor antenna even in steel frame buildings. Has every modern feature, including power detection, Band Pass tuning, and heavy aluminum chassis.

NATIONAL CO. INC., Malden, Mass.

Est. 1914

Write today for full technical information mentioning Radio Broadcast.

NATIONAL SCREEN-GRID—MB-29

A Radio Parts Guide

THE NEW YAXLEY

Catalog



Send for it today for complete listings of Radio Convenience Outlets, Connector Plugs, Rheostats, Fixed and Grid Resistances, Jacks, Jack Switches, Phone Plugs, etc.

YAXLEY MFG. CO. Dept. B, 1528W Adams St., Chicago, Ill.

HARNESSING A MIGHTY POWER

—your radio!

A delicate, intricate network of coils and transformers—cascading amplifications tube by tube.

Such power must be harnessed—if the result is to be a smoothly flowing, clear reception.

A CENTRALAB volume control in your radio does just that . . . and it does it smoothly . . . silently . . . surely. It means much if your radio is CENTRALAB equipped.

Write for free booklet "Volume Controls, Voltage Controls, their uses."

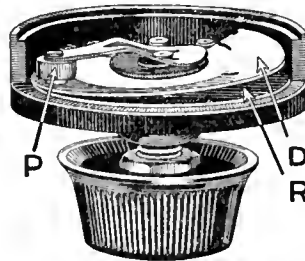

This shows the exclusive rocking disc construction of Centralab volume control. "R" is the resistance. Contact disc "D" has only a rocking action on the resistance. Pressure arm "P" together with shaft and hushing is fully insulated.

Centralab

CENTRAL RADIO LABORATORIES
20 Keefe Ave., Milwaukee, Wis.



(Continued from page 185)

number of spare parts, so he has more floating capital upon which to operate. And the regional factory can train its own mechanics, offering them steady employment and good wages, so the skilled labor problem so bothersome to the small dealer is solved. All that the dealer has to employ is a good diagnostician and a general helper, to attend to the attentive-maintenance service.

The Financial System

The regional repair factory should be financed by a holding company, which could be formed by the manufacturers and in which distributors and dealers should in time be permitted to buy stock. In one Western state, the dealers themselves have financed such a factory, each buying stock according to the volume of his normal repair business. On principles, however, the automobile industry seems to feel that the original burden should be borne by the man with the most money, the manufacturers; and that the dealer will be doing his share at first by sending business to the factory, thereby making it profitable.

HOW WE LOOK AT SERVICE PROBLEMS

(Continued from page 146)

up. Remember also that technical knowledge and handiness with tools are important but that handling the customer is just as important. Don't employ a man that you wouldn't be willing to send to your own home. Get men with a good education, if you can, and men who have a real flair for radio. If these men intend to stay with the game a little overtime will not scare them. And when you get a good man give him a square deal. Pay a fair wage and a commission on sales.

A few experiences showing the nature of the problems that the serviceman is called upon to solve may be of interest. The following paragraphs describe average calls, picked at random, which show some of the things the author has run up against recently.

The other day I had a report marked "No reception." A Czecho-Slovak bought a QD Freshman and we installed the set and antenna. The Czech moved, and moved the set. At the new location what did I find? The set was properly grounded. The antenna lead-in went to a woven-wire fence—and the fence was grounded. I explained to the customer the need for a proper antenna.

About a week ago I delivered a neodyne console, complete with power supply and loud speaker. Shortly after I got another "No reception" report.

All the tubes were burned out except the detector tube. The set tester showed current at sockets o.k. with one exception. The set had apparently been taken out of the console, examined, and then put back by unfamiliar hands. I found, after some questioning, that one of the boys in the family was a radio "bug" and had worked in a radio factory neutralizing sets. He certainly neutralized that one.

Some people like company. I have had several calls where "No reception" was reported and an examination showed that set and connections were all right. The a.c. plug was connected too. Some of these people admitted that they just wanted someone to talk to. I suppose that the grocer and the ice man do get to be an old story at that.

Wric changed its wavelength from the Back Bay to the North End, if you know your Boston. We got all sorts of complaints and inquiries as to how to separate wric, wbz, and wpg. An 0.00025-mfd. fixed condenser in the antenna lead-in fixed some of these.

Stop A.C. Noise!

Improve Selectivity!

PLUG in a Falck Claroceptor between wall socket and radio set and eliminate "static" from motors, street cars, telephones and electrical appliances. This new improvement by a pioneer radio parts manufacturer grounds and thus blocks out line interference noise and radio frequency disturbances. Also improves selectivity and distance. Requires no changes in set. Measures just 3½ x 5½ x 2½ inches. Thousands now all over America use the Claroceptor for clearer A. C. reception. Get one right away—at radio parts dealers. Write for descriptive folder.

\$7.50 complete with cord and plug

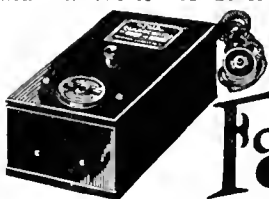

Falck

CLAROCEPTOR

Built by ADVANCE ELECTRIC CO.
1260 W. Second St. Los Angeles, Calif.
JOBBERs and DEALERs, GET OUR PROPOSITION

Makes Your Radio BEHAVE!

Free Bulletin
Write Dept. RBL

The New AMPERITE for electric radio improves reception—makes tubes last longer. Eliminates disturbing line voltage fluctuations. No radio can be modern without it.

AMPERITE Corporation
561 BROADWAY, NEW YORK

AMPERITE
Self-Adjusting
LINE VOLTAGE CONTROL

ROBERT S. KRUSE
Consultant and Technical Writer
103 Meadowbrook Road, West Hartford, Conn.
Telephone Hartford 45327

- ADVENTURE
- EXPLORATION
- CURRENT EVENTS
- BIOGRAPHY — SCIENCE
- PERSONALITIES
- BUSINESS — EDITORIALS

The BEST of all these in

WORLD'S WORK

WORLD'S WORK Garden City, New York

Speed . . . Accuracy . . . Skill in trouble-shooting



"Supreme" Features

The Supreme oscillation test gives the only dependable test on tubes; tubes tested under actual operating conditions. The Diagonometer tests all tubes, including screen grid.

Tests both plates of 80 type rectifier tubes; provides bias emission tests on tubes. All tubes tested independent of radio. Locates unbalanced secondaries. Reads both positive or negative cathode bias.

Provides D. C. continuity test without batteries.

Furnishes modulated signal for testing synchronizing, neutralizing, etc.

Aligning of condensers by Thermocouple meter or A. C. meter.

Neutralizing with tubes used in the set.

Tests gain of audio amplifiers.

3 precision meters; one 4 scale D. C.

Voltmeter 0/750/250/100/10 volts, resistance 1000 ohms per volt. One 4 scale A. C.

Voltmeter 0/750/150/16/4 volts. One 3 scale Mil-ammeter 0/125/25 mills. 0/-1/2 amps. External connection to all apparatus.

Universal analyzer plug.

Thermocouple meter for varied uses.

Measures resistances in three ranges, 150 to 30,000 ohms (calibration curve furnished) 10-200 ohms to 25 ohms.

Makes all analysis readings.

Screen grid socket analysis without producing oscillation.

Measures capacity of condensers .1 mfd. to 9 mfd.

Tests charger output by meter.

Bridges open stages of audio for tests.

Contains 500,000 ohm variable resistor, 30 ohms rheostat and .001 mfd., .002 mfd. and 1 mfd. condensers for testing.

Detects shorted variable condensers without disconnecting r.f. coil.

Provides low resistance measurement for rosin joints.

Provides simultaneous plate current and plate voltage readings and the customary readings of A. C. and D. C. filament voltage, grid voltage, cathode bias, screen grid voltage, line voltage, etc.

The Supreme laboratory test panel is equipped with a variable condenser for varying the frequency of the oscillator.

Provides many other tests, readings and functions.

"AMAZING!" That's the way radio technical men speak of the SUPREME DIAGNOMETER. Its numerous remarkable qualities have brought the complete facilities of the laboratory to the home of the set-owner—adding speed and accuracy to the skill of the service-man. No other device approaches it in flexibility, completeness and range. Set testers check only 29%-40% efficient in comparison with its capacity.

By equipping with the SUPREME DIAGNOMETER you assure 100% service satisfaction, service that no radio-man but one equipped with a DIAGNOMETER can rival.

Comes in handy carrying case providing compartments for all tools and spare tubes, or at the option of the purchaser, in an even smaller case, for the service-man who does not wish to carry tools and tubes in same unit.



—and now the most practical laboratory test panel ever produced

In keeping with SUPREME standards, unquestionably the most advanced test panel ever produced. Of heavy re-inforced Bakelite, it adds to the trim workmanlike appearance of laboratory or shop and assures sturdy service. Makes the DIAGNOMETER a dual purpose instrument—shop or portable service—instantly disconnectable.

SUPREME

Radio Diagonometer

conceivable
Makes every test on any Radio Set-



Symbol of a higher type of radio service. Cash in on the prestige of the Supreme Service League and the benefits to its members. Write for information.



Most good distributors stock the Supreme. If yours cannot supply you, address, for full information, without obligation,

SUPREME INSTRUMENTS CORPORATION

358 Supreme Bldg., Greenwood, Miss.

RADIO BROADCAST

PUBLISHED FOR THE RADIO INDUSTRY

WILLIS KINGSLEY WING Editor
 KEITH HENNEY Director of the Laboratory
 HOWARD E. RHODES Technical Editor
 EDGAR H. FELIX Contributing Editor



VOL. XVI. NO. 4

Contents for February, 1930

Review - - - - -	W. K. W.	193
Facts Replace Estimates More Truth in Advertising "Permanent Commission"	Flirtations Radio Business New Uses for Radio	
Mergers in the Radio Industry - - - - -	Edgar H. Felix	194
The Market for the Battery Set - - - - -	T. A. Phillips	196
The March of Radio - - - - -	An Editorial Interpretation	198
The New Day in Radio Educational Broadcasting	Too Much Iceing Is Indigestible An Invitation to Mr. Schnette	
Professionally Speaking - - - - -	Keith Henney	200
Two Needed Developments	Regarding Radios in Autos	
The Inside Story of the Brunswick - - - - -	A Page of Pictures	201
The R.C.A. Theremin - - - - -		202
A Production Testing System (Part II) - - - - -	J. A. Callanan	204
The Multicoupler Antenna System	Ernest V. Amy and J. G. Aceves	206
The 1930 Model Hi-Q Receiver - - - - -	Curtis W. Hamilton	210
Band-Pass Filter Circuits - - - - -	E. A. Uehling	212
"Radio Broadcast's" Engineering Review Sheets - - - - -		215
Tubes as Amplifiers	Simple L x C Measurements	
The Supreme Diagonometer - - - - -	Floyd Fausett	217
Push-Pull A.F. Amplifiers - - - - -	J. M. Stinchfield	219
Strays from the Laboratory - - - - -	Technical Shorts	223
A Radio Manual Causes of A. C. Hum	The Radiola 21 All About Electricity	
Book Reviews - - - - -		224
Elements of Radio Communica- tion	International Aspects of Radio Communication	
Radio Telegraphy and Telephony Mathematics of Radio	Radio Receiving Tubes	
The Serviceman's Corner - - - - -		226
Points on Victor Short Cuts to Neutralization	An Automatic Switch In the Service Laboratory	
"Radio Broadcast's" Set Data Sheets - - - - -		230, 232
The Amrad Model 31 The Sparton Model 301	The Fada Models 16, 17, 32	
News of the Radio Industry - - - - -		234
Shall We Buy or Make Parts? - - - - -	Dawson J. Burns	239
In the Radio Marketplace - - - - -	Offerings of Manufacturers	240
The Radio Dealer's Directory of Recent Price Changes - - - - -		241
Radio Broadcast Laboratory Information Sheets	Howard E. Rhodes	242, 244, 246
No. 319. Apparent Demodulation of a Weak Signal	No. 324. Hum vs Volume Control	
No. 320. Apparent Demodulation of a Weak Signal	No. 325. Beat-Frequency Oscil- lators	
No. 321. Service Procedure	No. 326. Beat-Frequency Oscil- lators	
No. 322. Inductance of Coils	No. 328. Fidelity in Modern Sets	
No. 323. Inductance of Coils		

The contents of this magazine are indexed in *The Readers' Guide to Periodical Literature*, which is on file at all public libraries

. . . among other things

FOR THE first time, complete data is presented on the "Multicoupler" antenna system, developed some months ago in New York. The system has been of great interest to engineers because of its simplicity and low cost. Mr. Amy and Mr. Aceves, co-designers of the system, describe it fully on page 206 of this issue.

ANOTHER OF Mr. Uehling's valuable mathematical articles on theory of receiver design is a part of this issue. Mr. Uehling was formerly a member of the research staff of Fada Radio in New York. Some months ago he returned to the University of Michigan for graduate study in physics.

RADIO BROADCAST readers will remember two interesting papers by J. M. Stinchfield of the Cunnigham engineering department which appeared in our August and October, 1929, issues. The August article discussed "Calculating Detector Output" and the October paper "Grid Leak vs. Bias Detection." Mr. Stinchfield's article in this issue deals with push-pull audio-frequency amplifiers.

THE MARCH RADIO BROADCAST will contain contributions from H. D. Oakley, of the General Electric engineering department, a paper from the Ward Leonard Laboratory, the third article in Mr. Callanan's series on factory production test methods, a description of the ingenious and compact record-changer developed in the Technidyne Corporation laboratories, and a number of other interesting articles, in addition to all our regular departmental features.

OF ESPECIAL interest is the article from Ward Leonard which describes for the first time anywhere the "Adaptoron." This is a compact motor-driven unit for the conversion of direct current of any of the common commercial voltages to alternating current. The article describes the unit technically and discusses its application. With this unit, which is approximately 80 per cent. efficient, a 32-volt d.c. farm-lighting system will provide 110 volts a.c. to energize a standard a.c. broadcast receiver. The conversion unit will perform the same function on any commercial d.c. supply. This article, we are sure, will be awaited with the greatest interest. Mr. Oakley will describe the signal generator developed by the General Electric Company giving full data on circuit and operation. We shall publish two other articles from Mr. Oakley dealing with applications of the device.

TERMS: \$4.00 a year; single copies 35 cents; All rights reserved. Copyright, 1930, in the United States, Newfoundland, Great Britain, Canada, and other countries by

DOUBLEDAY, DORAN & COMPANY, INC., Garden City, New York

MAGAZINES
 COUNTRY LIFE WORLD'S WORK THE AMERICAN HOME RADIO BROADCAST SHORT STORIES LE PETIT JOURNAL EL ECO WEST
 BOOK SHOPS (Books of all Publishers)

NEW YORK: <LORD & TAYLOR, JAMES McCREERY & COMPANY, PENNSYLVANIA TERMINAL, 166 WEST 32ND ST., 848 MADISON AVE., 51 EAST 44TH STREET, 420, 526, bnd 819 LEXINGTON AVENUE, GRAND CENTRAL TERMINAL, 10 WALL STREET> ATLANTIC CITY: <2807 BOARDWALK> CHICAGO: <75 EAST ADAMS STREET> ST. LOUIS: <310 N. 8TH ST. bnd 4914 MARYLAND AVE.> CLEVELAND: <HIGBEE COMPANY> SPRINGFIELD, MASS: <MEEKINS, PACKARD & WHEAT.

OFFICES

GARDEN CITY, N. Y. NEW YORK: 244 MADISON AVENUE. BOSTON: PARK SQUARE BUILDING. CHICAGO: PEOPLES GAS BUILDING. SANTA BARBARA, CAL. LONDON: WM. HEINEMANN, LTD. TORONTO: DOUBLEDAY, DORAN & GUNDY, LTD.

OFFICERS

F. N. DOUBLEDAY, Chairman of the Board; NELSON DOUBLEDAY, President; GEORGE H. DORAN, Vice-President; RUSSELL DOUBLEDAY, Secretary; JOHN J. HESSIAN, Treasurer; LILLIAN A. COMSTOCK, Ass't Secretary; L. J. McNAUGHTON, Ass't Treasurer

REVIEW

▲ **FACTS REPLACE ESTIMATES.**—Every householder will be asked in the 1930 census "Do you own a radio set (Yes) (No)?" On completion of the census for the first time in radio history since broadcasting, the industry will know definitely how many sets actually are in use. The best present estimate gives 12,000,000 sets in use. Statistics are where the industry is weakest. Accurate consolidated figures have never been available to show the number of sets and tubes made annually, sales to distributors and dealers, and sales by dealers to customers. Companies all refuse figures on their manufacture and sale with the result that all do business in a thick haze of incomplete information. Sources of statistical estimates previously have been: McGraw-Hill Company (*Radio Retailing*); Department of Commerce (Electrical Equipment Division, aided by National Electrical Manufacturers Ass'n.); National Broadcasting Co.; Research Division, **RADIO BROADCAST.**

▲ **MORE TRUTH IN RADIO ADVERTISING.**—The National Better Business Bureau, an independent organization set up by advertisers themselves, calls set manufacturers to task for the present vogue of "circus advertising." Copy of 26 leading manufacturers has been analyzed showing most popular claims are: (1) "greatest"; (2) "finest"; (3) "biggest," "fastest," "clearest," "highest," "longest," "most beautiful." Manufacturers are urged to discontinue voluntarily practising these absurdities. Claims of not guilty were made by Edison and others.

Meanwhile inside the trade itself are charges and counter-charges that advertising concessions to dealers, large chains and others, have been one of radio merchandising's worst evils during 1929. Heavy "advertising" appropriations granted to dealers and distributors by set makers are said to be polite language for price cutting in the battle for distribution.

▲ **"PERMANENT COMMISSION."**—On December 19, the President signed the bill passed by Congress to extend the life of the Federal-Radio Commission from December 31, 1929, "until otherwise provided by law." The Act authorizes the Commission to establish an engineering department headed by a chief engineer at \$10,000 a year and two assistants at \$7500. Other much-disputed sections in the Radio Act were not disturbed, Congress being disposed

SOME OF the events in the world of radio in recent weeks may have escaped you. A few of the more important, to our way of thinking, are presented on this page.

to let these dogs sleep until the pending Communications Commission Bill (S.6) is disposed of.

The Commission is still in hot water over the enforcement of provisions of the so-called Davis "equalization" amendment to the Radio Act which the present Act does not mention, although many Senators and Representatives do not approve of the equalization feature nor the way in which the Commission has carried it out.

▲ **FLIRTATION.**—Bishop, McCormick & Bishop, Dodge distributors for New York City and suburbs, in December took on sales and service of Grebe radio exclusively. Bishop, McCormick & Bishop handle Transitone automobile radios on Dodge cars. Douglas Rigney, Grebe salesman, says: "Automobile Row, centrally located in every large city, will soon become a radio salon in addition. The public reaction is sure to be favorable. Sets will be sold amid engaging environment provided by substantial and outstanding concerns to whom people are accustomed to look for quality products. . . . Probably the service factor will appeal most strongly to the public, knowing, I mean, that a house especially trained in service is always at command when an emergency requires." The General Motors Radio Corporation have as yet made no announcement of their future distribution plans. While radio is aiding the automobile dealer, Copeland refrigerators are being advertised in dealer-trade papers as a line advantageous to radio dealers from sales and service standpoint.

▲ **RADIO BUSINESS.**—Overproduction and overcapacity are word-tags seized on by all in the radio business to explain away difficulties faced by the industry which began to be noticed just before the Wall Street débâcle. *Radio Retailing's* December number reveals an early-Summer survey of plant capacity showing tremendous increases. However, their warning of danger to the industry was presented two months after results of the industry's bad planning became apparent. Average set prices are lower than ever before and sales are generally

reported as holding up well during the holiday season. Public appetite for radio has not decreased but manufacturers' estimates of the public's capacity to absorb *their* products were generally overestimated. Radio advertising is slowing up with some cancellations in general and trade magazines.

Earl, Freed, Sonora, A.C. Dayton, Marti, Neonlite Tube, Buckingham, United Reproducers, and Erla are reported in receivership proceedings.

New models will probably not be shown by any manufacturer of importance this year before the Atlantic City Trade Show in June. In 1929, many new models were announced long before Trade Show. (Atwater Kent's screen-grid Model 55 was announced April 1, 1929).

Jenkins Television held a public demonstration early in January, preceded by a New York showing of Baird's English system. Sonora showed a home sound movie device which will sell around \$350. It contains a projector, disc phonograph, electrical amplifier, and loud speaker system in one cabinet.

▲ **NEW USES FOR RADIO?**—The start of a really intensive effort to cultivate new markets for radio is shown in current interest in radio sets for automobiles. A leader in this field is the Automobile Radio Corp. (Transitone), partly owned by Chrysler, which has already equipped some Dodge and Chrysler cars. All Cadillac and LaSalle closed cars now leave factory with concealed roof antennas installed, and a set complete with tubes and magnetic loud speaker, is available for these cars at \$150. Sonora recently announced a five-tube set for installation in any type of car. The trade as yet is not enthusiastic over the possibilities of the market, but signs seem to point to widespread efforts next season. Larger possibilities lie in the portable receiver field, in our opinion. A good portable can be used in the car, the beach, your summer camp, boat, while travelling by boat or train, or put in the house and used as an alternative set there. The difficulty here, as in the automobile set, is performance. More efficient tubes and loud speakers are required before the ideal can be approached.

Majestic has organized a railroad department and installations have already been made on some mid-western trains. Canadian National Railway trains have been radio-equipped for some time. The Broadway Limited and Century, however, are still radio-less.



By EDGAR H. FELIX

MERGERS IN THE

IN ITS original definition, merger meant the complete absorption and obliteration of a lesser unit by a larger one. Now that term is applied to even such loose combinations as those in which the component units maintain their individual identity, their freedom of policy, and their competitive relationship with the other associated units. Even with so broad a definition of merger, most of those which have taken place in the radio industry have not been of a far-reaching character. None are the equivalent of the United Cigar-Schulte merger for example, which joined the two largest and longest established retail tobacco chains.

Two Large Mergers

Only two mergers in the history of the industry may be termed as gigantic and both of them concern the same group. The first is the historic patent pool of leading electrical manufacturing interests which led to the formation of the Radio Corporation of America in 1920, and the second, the merger of the company so formed with the Victor Talking Machine Company in 1928. No other major units in the field reached a position of leadership as the direct result of merger operations.

For the purposes of analysis, it is convenient to classify mergers in the radio field according to the purpose accomplished, as follows:

- (1) Building of patent position
- (2) Diversion of music industry into radio
- (3) Expansion

The merger which led to the formation of the Radio Corporation of America in 1920 is the outstanding example of the first classification. Government officials encouraged its formation in order that there might be established an American

international communications system, independent of foreign-owned cable links or radio stations. To this end, the General Electric Company, the Westinghouse Electric and Manufacturing Company, the American Telephone and Telegraph Company, the United Fruit Company, and the Wireless Specialty Apparatus Company advanced capital and pooled patent rights in behalf of a new company, the Radio Corporation of America. The pooling of patent rights of the founding companies was considered necessary because no one of them had sufficient patent rights individually to embark upon the manufacture of radio transmitting and receiving equipment without fear of litigation brought by the others.

Having agreed on these first steps, however, the advantages of further extending the scope of the agreement became apparent. Each of the companies involved secured free license to the patents held by all the members of the group for specific fields; for example, the American Telephone and Telegraph Company in wire and radio telephony; the Westinghouse Company in non-commercial receiver equipment manufacture; the General Electric Company in the manufacture of commercial ship telegraph transmitters and receivers, and so on. They also remembered the then insignificant amateur radio experimenter business, which totaled about \$200,000 a year. Rights to manufacture equipment for this field was extended to the Westinghouse and General Electric companies and its sale was made a side line of the Radio Corporation.

The Mackay Group

The Mackay interests have attempted to build up a competitive communications system through the acquisition of Federal Telegraph. DeForest successfully sustained his vacuum-tube circuit patents over Armstrong recently and,



RADIO INDUSTRY

June—Stiner

through shop rights under them, owned by the Federal Telegraph Company, the Mackay interests have been able to establish a communications system with at least one trans-oceanic link already in operation. Extensive plans for the establishment of an intracontinental communications system have been formulated and frequencies have been allocated by the Federal Radio Commission to make its consummation possible. Allied with the Mackay group is the Kolster Radio Corporation, which possesses manufacturing facilities for making the receiver and transmitter equipment required, while the DeForest Company is available for production of the necessary tubes.

A number of other instances may be cited of the merger of companies by purchase for the acquisition of patent rights. For example, Grigsby-Grunow-Hinds (now Grigsby-Grunow, manufacturers of Majestic receivers) purchased the Pfanstiel Company to secure its R.C.A. license. In the same manner, the Philadelphia Storage Battery Company bought the D. J. Murdock Company, a pioneer part and set manufacturer. These last two were true mergers in that they represented the extinction of the smaller units merged.

The United States Radio Corporation will be remembered as a similar combination, established to divide the obligations of an R.C.A. license among five receiver manufacturers. The U. S. Radio and Television Corporation is the successor to this group.

The Second Classification

In the second classification, the surrender of the music industry to its former rival, the radio industry, the most important is the merger of Victor and the Radio Corporation of America. In this instance, both companies contributed equally,

Victor having a well-established distribution position through the music trade, valuable contracts with world-famous artists, and excellently organized manufacturing facilities. The Radio Corporation of America contributed patent rights and experience in the radio field. Its close affiliation with the National Broadcasting Company offered a valuable outlet for the utilization of Victor artists. The substantial character of this merger is evidenced by the fact that Westinghouse and General Electric have recently transferred their radio engineering activities to the unified laboratories in Camden and that these companies are to discontinue the manufacture of receivers for distribution through the Radio Corporation of America in favor of concentrating that production in the Victor plant at Camden. RCA, not confining its alliance with the music field to this country alone, quietly purchased, not long ago, a controlling interest in His Master's Voice, "HMV," of London, which is quite the largest gramophone company in the world, exceeding even Victor in this country in size.

Radio-Phonograph Mergers

Each of the leading phonograph companies have established a radio connection of one kind or another. Brunswick is linked with Bremer Tully through a major purchase of stock. Edison entered the radio field through the acquisition of Splitdorf. Sonora recently purchased Federal. Columbia has a close contract arrangement with Kolster, somewhat similar to that which the Radio Corporation extended to Victor before the merger took place. Some of the piano companies have also gone into the radio field, for example, Everett Piano is merged with the Howard Radio Company, the latter moving

(Continued on page 243)



The MARKET for the

By T. A. PHILLIPS

Manager, Research Division, Doubleday, Doran & Co., Inc.

BATTERY-OPERATED receivers, with the sensitivity, selectivity, simplicity, economy, volume, and fidelity requirements comparable with socket-powered radio sets have been conspicuous by their absence from the market. Recent announcements from several manufacturers indicate that efficient battery-operated receivers, equal in every respect to the best screen-grid socket-powered set, have been developed.

How important is the need for this type of receiver? Will it actually greatly increase radio sales and where will it sell most readily?

It is estimated that 10,300,000 homes in the United States are unwired and that in at least 5,000,000 of these are live radio prospects. The National Carbon Company states that out of 5,371,000 farms owned by white families only 1,000,000 are served by electricity and only 25 per cent. are equipped with radio. In addition, many small towns do not have electric current. These homes constitute the primary battery set market.

How important is the present battery set market and where are battery sets now sold? This type of receiver represents about 12 per cent. of total set sales. More than one third are sold in towns under 10,000 population and one half in towns under 50,000 population. Only a little more than one quarter of all radio sales, however, are in towns under 50,000 population.

Further study discloses that battery sets constitute from 15 to 40 per cent. of total set sales in small towns and less than 5 per cent. of total set sales in towns over 50,000 population. It can be taken for granted, then, that battery sets will find their best market in the small towns of rural districts.

How important is the rural town market? If only 28 per cent. of all radio sales are in small towns and farms, and only 12 per cent. of all sets sold are battery sets, is it worth while to pay much attention to the small-town and farm market? The automobile manufacturers know the small-town and farm market is very important. Five out of six farmers own automo-

biles. Of the automobile registrations 55 per cent. are in towns under 10,000 population and 75 per cent. in towns under 50,000 population. Of all cars in use 25 per cent. are farm owned. It should be equally important to set manufacturers.

Let us take a bird's eye view of the wholesale trading area of four towns, all in the State of Indiana and within fairly close proximity of each other. Many other communities might be chosen but out of fifty towns studied these four cities are

Battery Set vs. Total Set Sales

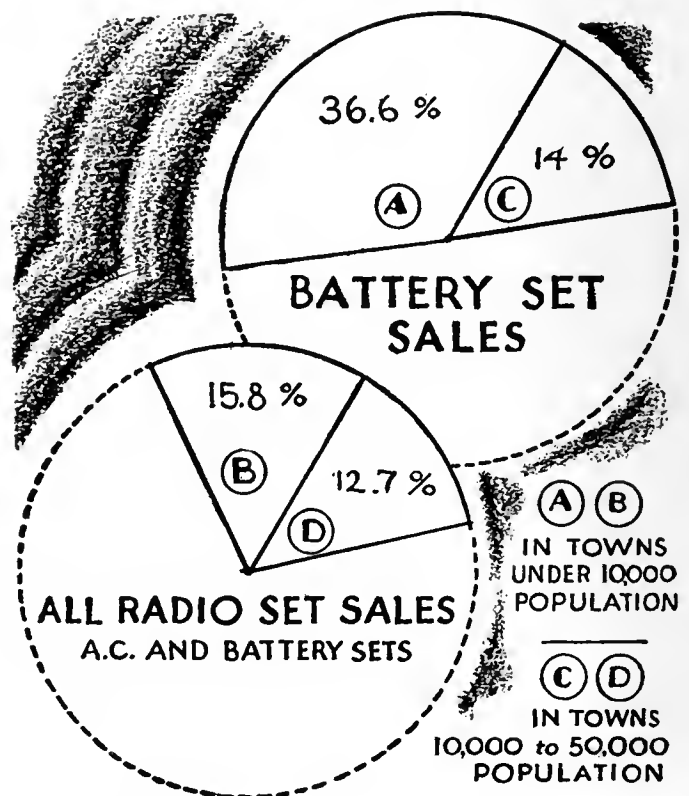

BATTERY SET

FOUR REPRESENTATIVE TRADING AREAS

	Evansville	Terre Haute	Fort Wayne	South Bend
City population (1920)	85,264	66,083	86,549	70,983
Trading area population	766,470	386,093	383,789	356,064
Rural population	536,150	250,503	207,521	155,311
Per cent. rural	70%	65%	54%	43%
Per cent. wired homes	42%	57%	62%	75%
Relative set sales*	193	198	765	1,789
Battery set sales†	20%	27%	5%	5%

*Relative radio set sales represent total set sales for a recent three months' period reduced to sets sold per 100,000 population.
 †Battery set sales are given in per cent. of total set sales.

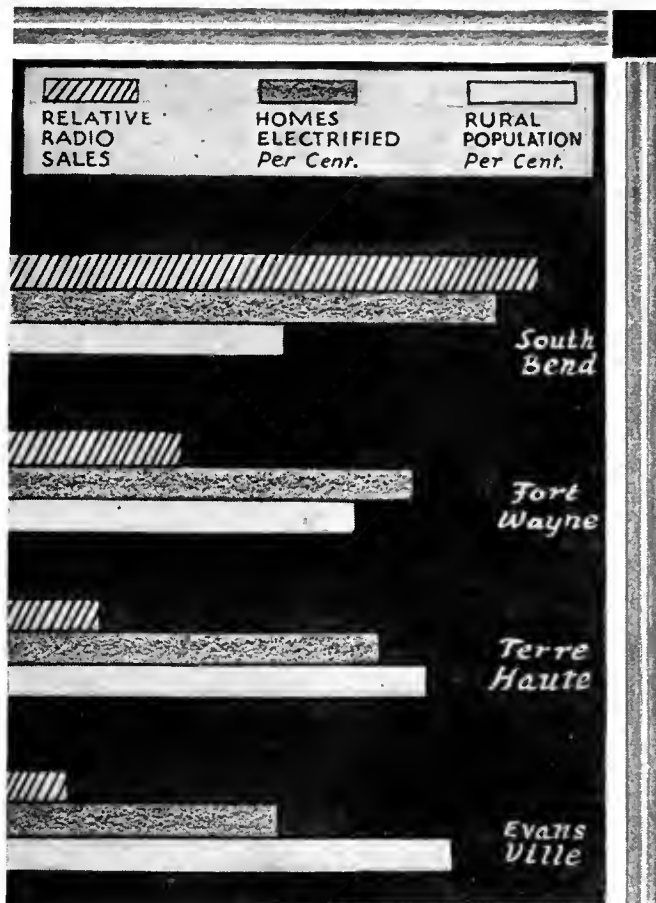

more typical of the various local conditions we will discuss. The towns to be studied are, Evansville, Terre Haute, Fort Wayne, and South Bend, Indiana. (A map on facing page illustrates the extent of the territories considered in the study.)

Here are four cities with many common attributes. They are all about the same size. Their trading areas are practically the same in population also, with the exception of Evansville. There are significant differences, however. Evansville and

How Various Trading Areas Compare

TOWNS WHOSE WHOLESALE TRADING AREAS SELL THE SMALLEST PROPORTION OF BATTERY SETS TO TOTAL SALES

Wholesale Territories of	Percentage Battery Set Sales	Wholesale Territories of	Percentage Battery Set Sales
1. Erie, Pa.	0.45	16. Detroit, Mich.	3.92
2. Corpus Christi, Tex.	1.27	17. St. Petersburg, Fla.	4.00
3. Scranton, Pa.	1.51	18. Chicago, Ill.	4.10
4. Charleston, N.C.	1.56	19. San Francisco, Cal.	4.20
5. New Orleans, La.	1.73	20. Lynchburg, Va.	4.26
6. Dallas, Tex.	2.47	21. Augusta, Me.	4.35
7. Huntington, W. Va.	2.63	22. Beaumont, Tex.	4.35
8. Charlotte, N. C.	2.74	23. New York, N. Y.	4.43
9. Cleveland, Ohio	3.06	24. Richmond, Va.	4.62
10. Sacramento, Cal.	3.23	25. Norfolk, Va.	4.63
11. Wilmington, Del.	3.33	26. South Bend, Ind.	4.68
12. Los Angeles, Cal.	3.39	27. Greenville, S. C.	4.76
13. Baltimore, Md.	3.53	28. Milwaukee, Wis.	4.82
14. Springfield, Mass.	3.58	29. Miami, Fla.	4.90
15. Denver, Colo.	3.71	30. Fort Wayne, Ind.	4.97

TOWNS WHOSE WHOLESALE TRADING AREAS SELL THE GREATEST PROPORTION OF BATTERY SETS TO TOTAL SALES

Wholesale Territories of	Percentage Battery Set Sales	Wholesale Territories of	Percentage Battery Set Sales
1. Grand Forks, N. D.	39.62	13. Evansville, Ind.	19.65
2. Orlando, Fla.	35.71	14. Altoona, Pa.	19.44
3. Mason City, Iowa	30.26	15. Davenport, Iowa	18.62
4. Charlottesville, Va.	28.57	16. Winona, Kan.	18.62
5. Savannah, Ga.	28.57	17. Ottumwa, Iowa	18.42
6. Sioux City, Iowa	28.37	18. Knoxville, Tenn.	18.09
7. Terre Haute, Ind.	27.17	19. Wichita, Kan.	17.26
8. Aberdeen, S. D.	26.84	20. Bloomington, Ill.	17.00
9. Minto, N. D.	26.32	21. Wilkes Barre, Pa.	16.29
10. Bismarck, N. D.	25.00	22. Cedar Rapids, Mich.	15.79
11. Hutchinson, Kan.	25.00	23. Atlanta, Ga.	15.09
12. Paducah, Ky.	25.00	24. Williamsport, Pa.	15.00

Terre Haute are surrounded by farming communities while Fort Wayne and South Bend are the focal points for small suburban towns. In other words, the two former cities are the shopping centers of rural communities, while the latter are the shopping centers of suburban homes. It naturally follows, also, that Fort Wayne and South Bend have more domestic lighting customers than Evansville and Terre Haute.

Note that as the rural population increases with a corresponding decrease in the number of domestic lighting customers, radiosales decrease tremendously. South Bend with the smallest rural population sold four times as many radios as Evansville and eight times as many as Terre Haute. Fort Wayne sold twice as many as Evansville and three times as many as Terre Haute.

The purchasing power in these four areas is practically the same. Is it not reasonable to suppose that a battery-operated set giving the same satisfaction as the screen-grid a.c. receivers would lessen the discrepancies between sales in these towns?

It is, of course, dangerous to draw any specific conclusions from a study of four cities but there is no question that this state of affairs can be duplicated many times throughout the United States. Is it possible that instead of a 3,000,000 production year we will have a 6,000,000 production year as soon as families not able to take advantage of the a.c. receiver discover a battery set that meets their requirements?

Why not? Let us quote from a letter sent to a radio manufacturer by a dealer in Shelbyville, Indiana:

"The farmers in this district have had two poor years and general business conditions in Shelbyville are considerably below average but the new battery set is helping to put radio sales ahead of last year. Our only regret is our failure to see the enormous possibilities of the market and make an earlier start. We had been under the delusion that the market for battery-operated sets was a thing of the past along with the crystal receiver.

"Inquiries from farmers concerning the new screen-grid battery sets opened our eyes and in October, and in November we sold them as fast as we could get them in stock. This profit is like finding money on the street."

The MARCH

A Purification Process is Under Way
Export—Another Avenue for Development

The New Day in Radio

ANDREW C. PEARSON, president of the National Publishers' Association, in a nationwide broadcast addressed by the United States Chamber of Commerce to business and industrial leaders of the country, remarked that only the radio and automotive industries are seriously inflated. It is easy to generalize upon the causes which have led up to this situation, but to appraise the position of individual manufacturers and the prospective developments of the immediate future is made exceedingly difficult by the limited statistical data available.

The leaders of the industry are given to buoyant optimism and to no small amount of exaggeration. Were we to credit the publicity issued by manufacturers during the last year, the production capacity of the industry would be computed at somewhere between 12,000,000 and 15,000,000 receivers. Unquestionably, the mere possession of these facilities represents an overhead which adds materially to the cost of receivers actually sold the public.

On the other hand, so large a proportion of radio manufacture is bench assembly, involving inexpensive tooling, that converting these excessive facilities to other uses is a task of small magnitude, considerably smaller than was required, for instance, to change over munitions plants to peacetime uses. Diversification of activities is one of the best ways to stabilize receiver manufacture and to defeat the seasonal character of radio production. Another avenue is the development of export business, necessarily a slow and difficult process, but one which will ultimately exert as great a stabilizing influence as it has already done for the automotive industry. None of these possibilities, however, bear upon the immediate situation because of the time and capital required to develop them. The industry must learn, in times of prosperity, to erect defenses against troubled times.

The measures being applied in the present emergency are not of a character to inspire confidence in their effectiveness. The most definite trend discernible at the present writing is reduction of list prices. That invites a broader market and also the maintenance of excessively large production facilities. It may exert an immediate curative tendency, but it also brings us nearer to the point of profitless production. The trend toward lower prices is of advantage only if accompanied by a reduction in the number of active manufacturing units.

Another measure stimulated by the emergency situation is the attempt to increase the number of selling outlets through consolidation with automotive distribution. This promises to doom us to another crisis as complex as that engendered by excessive expansion of production. The logic of combining automotive and radio distribution is irresistible but it cannot be accomplished on a widespread scale without painful disturbance of existing distribution relationships, and an educational process of no small magnitude. Desirable as the ultimate effects of such a readjustment may be, by reason of the



more efficient sales system resulting, the transition stage requires the elimination of the lesser radio retail outlets, with accompanying liquidation of their stocks under unfavorable conditions. The invariable effect of distress merchandising is to hold up the conservative buyer who waits for still lower prices.

Consequently, the adjustments required by the industry are of a fundamental rather than a superficial character. The problem is somewhat larger than waiting for a storm to blow over; it requires a complete realignment of production and distribution. Such a major readjustment is not effected in a day. Those organizations possessing far-seeing executive leadership, which can penetrate the fog that obscures the future, are destined to reap a tremendous reward. The opportunities in the radio industry are greater to-day than they have been at any time in its history. For once there is no band wagon upon which all may leap for an easy ride to success. The day of opportunism is over. Success requires intelligent direction and foresight. A process of purification is under way on a large scale, eliminating every weakness in the structure of the industry, the executive who is an engineer and not a business man, the optimist who knows only multiplication and has forgotten addition, the retailer who waits for customers, the manufacturer who imposes burdens upon the retailer too large for his abilities.

We venture to predict the coming of new leaders in the field, assuming management of existing companies with courage enough to support them. They will effect consolidations, diversification of manufacture into broader fields, reconstruction of selling outlets and distribution methods, and rounding out of receiver design to appeal to new markets. The radio market is still virgin territory, with less than one fourth of American families owning radio receivers and only a small proportion of the receivers in use sufficiently modern to resist the appeal of revitalized merchandising. This is the day of opportunity in radio, opportunity for intelligence, ingenuity, and leadership.



Educational Broadcasting

The gradual growth of educational broadcasting is beginning to reflect itself in the number of schools which are equipped for radio reception and the distribution of programs through loud speakers in every classroom. Most of the new schools in the more progressive cities, constructed within the last year, are fully wired so that program distribution systems can be installed. Some enterprising manufacturers have taken advantage of this trend either to present programs for school purposes or through the preparation of promotion material to aid dealers in selling schools. Atwater Kent has issued a pamphlet, "The Value of Radio to and in the Schools," and the Grigsby-Grunow Company, aided by the advice of Commissioner of Education Dr. John William Cooper, is presenting a bi-weekly feature, "The American School of the Air,"

OF RADIO

Who Is the Radio Protective Association?
New Progress in Broadcasting for Schools

on Tuesday and Thursday afternoons at 2:30. The programs are addressed to junior high school pupils. Tuesdays are devoted to the teaching and development of American history and Thursdays to a diversified program of literature, political science, health hygiene, American music, and nature study.

The Payne Fund of New York City has issued a report, "Radio in Education," prepared by Armstrong Perry, outlining in detail the educational experiments undertaken by stations throughout the country.

A questionnaire, sent by the Fund to 3000 county superintendents, principals, and teachers, indicates that 441 of the 471 replying would like a school of the air for the benefit of the 12,905 schools with the 42,043 teachers which they represent. Of the schools represented 5741 would become radio equipped as soon as programs are assured.

A check-up made by the Atwater Kent Company indicates that 360 sets have been sold to educational institutions for classroom broadcast reception. Some 20 to 45 per cent. involve multiple loud speaker installations, the largest being one of 30 loud speakers at Ferndale, Mich. The two educational broadcasts attracting the greatest attention are the Ohio School of the Air through WLW and the daily school programs of the Chicago Daily News through WMAQ. While the recognition of the Damrosch program has been widespread, the investigation did not disclose any schools in larger centers which have incorporated his lessons on music appreciation in their curricula. The same situation was found to apply to the music appreciation programs broadcast on the west coast by the Standard Oil Company of California.

Too Much Icing is Indigestible

Accompanied by a statement of altruistic objectives, the National Broadcasting Company announces that it has combined with Carl Fisher, Inc., and Leo Feist, Inc., to form the Radio Music Company. No one, after reading the statement, would be surprised if the R. M. Co.'s employes were required to wear white wings and halos. The object of the shrine of idealism which has been formed by this combination of interests is "the improvement of music in general, the advancement of American culture," and "to encourage young composers to write finer scores and to restore harmony and melody to music." Its operating policy is to be "almost revolutionary." We suspect that, if the company makes profits, the directors are pledged to commit suicide. It is peculiar to radio broadcasting that any enterprise which it undertakes must be labeled as a lofty inspiration, patently unattainable by persons not in close contact with the moral forces.

E. C. Mills, who will be remembered as the shrewd bargainer who held the radio broadcasting industry at his mercy as negotiator for the American Society of Authors, Composers and Publishers, is president of this majestic institution. It is

announced that there will be no boycotting of music not controlled by this new organization which should cause a sigh of relief to Friml, Schilkret, and Pasternack, if not to lovers of Beethoven, Wagner, and Puccini. The Radio Music Company will secure control of a sufficient number of composers so that it can dictate satisfactory terms for the vast amount of musical composition necessary to commercial broadcasting. It will profit not only through the payments made by radio advertisers for scripts and special arrangements, but by sharing in the profits made by merchandising the composer's works in every other field, such as music publishing and talking motion picture composition. In other words, it is to operate like the present N. B. C. Artists' bureau which bargains for radio talent at the lowest prices when it is the agent of commercial sponsors, assures artists, under its exclusive management, of maximum radio earnings and, to itself, commissions for every appearance of the artists under its control.

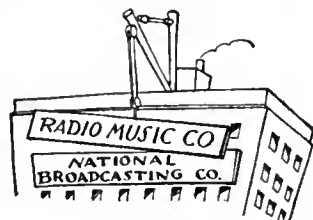

An Invitation to Mr. Schuette

There is no more mysterious character in the radio industry than that delight of the press, Oswald Schuette, spokesman for the Radio Protective Association and the public relations counsel to the newly founded Audio Research Foundation. Mr. Schuette makes a specialty of annoying the Radio Corporation of America and its associates by a skilfully executed policy of political palestrics and prolific publicity. He is seen frequently at the offices of the Federal Radio Commission, the Department of Justice, at the House and Senate, and the Federal Trade Commission. The utterances of certain public officials sometimes seem so remarkably like echoes of Mr. Schuette's whisperings that one is led to credit him with potent influence. Possibly monopoly baiting is so popular in political circles that scrutinizing the auspices under which monopoly baiters speak is not always carried out with the care which it deserves.

In fairness to the public and the press, Mr. Schuette should make public a complete list of his backers. These columns are open for the publication of such a list. Mr. Schuette's steadfast refusal to announce the membership of his Radio Protective Association lays him wide open to charges that he represents no one but himself, a charge which is probably entirely unfair.

The principal characteristics which commend Mr. Schuette are his zealotry and resourcefulness in his relentless fight against the predominant influences in the radio field. If there are monopolistic leanings in the radio field, Mr. Schuette is the watchful protector of the public interest. It is unfortunate that the foundation for his activities is so completely shrouded in mystery and that one cannot silence the suspicion that he does not speak for any of the leaders or any substantial element of the radio industry.

—E. H. F.

PROFESSIONALLY



SPEAKING

TWO NEEDED DEVELOPMENTS

TWO developments are needed to bring radio to the farmer; either one will do the trick, and both may revolutionize the entire radio business.

Of several characteristic radio receivers which are manufactured especially for the farm market, two require a plate current of 60 milliamperes from the B batteries, three require 25 milliamperes, one needs 20 milliamperes, and one operates economically on only 15 milliamperes. All need more than one ampere from the storage battery and most of them take about 1.5 amperes.

Considering a set which takes but 15 milliamperes from the B batteries, it is probable that one set of three batteries will last a year. This costs about \$12.00 and, when added to the cost of charging the storage battery (\$6.00 for the year), brings the farmer's cost of operating a set up to about \$1.50 a month. Such economy is secured by taking advantage of the superior sensitivity of the 200A special detector tube, and using a single 112A as power tube. Those sets which require 20 or more milliamperes of B power use the 171 type of power tube, and those which consume the uneconomical amount of 60 milliamperes use two of these tubes in push pull.

Contrast \$1.50 a month upkeep on the simplest farm set with a report of the Toledo Edison Company showing that 91 owners of a.c. sets on a 7-cent rate paid an average of \$6.02 per year for the pleasure of home entertainment via radio. Additional proof that the farmer must pay more than the city dweller for his radio is data from Stromberg-Carlson which states that Model 642 receiver consumes 90 watts, a charge of \$9.00 at a 10-cent rate for 1000 hours of service.

All of this points to the fact that the farmer pays heavily for his radio in spite of the fact that he needs it more than the city dweller, and should be able to get it at lower cost.

Without casting reflections on those set manufacturers who equip their farm radios with 112-type power tubes, it must be said that such receivers are reminders of the days of 1926. In order to supply a loud speaker from a single 112 tube the set must either operate at a very low level or at poor fidelity, so that overloading is not evident. It can be done by using a poor loud speaker, or by having an a.f. amplifier that definitely cuts off both high and low frequencies. In other words, an economical farm radio must operate at the expense of fidelity or volume!

What is needed is a new tube, one which will produce considerable power without the expenditure of 20-30 milliamperes of B battery current. Or, what is wanted is a new loud speaker, one that is much more efficient than present-day loud speakers so that on a power tube plate current of 10 milliamperes considerable volume at high fidelity will be possible.

The new tube will fix up the farmer; the new loud speaker may revolutionize the radio business. Suppose it were possible to obtain present-day volume and fidelity by using a 112 tube? Gone would be the day of 250-volt power packs taking 100 milliamperes; then the announcer could say of radio as he does of tobacco, "progress has been made."

REGARDING RADIOS IN AUTOMOBILES

Without appearing to judge the case before it is tried, we venture to offer an opinion on this business of radios for automobiles (see page 193). It seems to us that there are several people to be considered—the automobilist, the innocent bystander already bothered with noise from autos and in danger of being run over by one-arm drivers, and finally the set manufacturer.

The automobilist has about all he can do now to stay on the straight and narrow. Are we to have one-arm drivers to add potential sources of accident? And we cannot see how any-

one could enjoy much radio music while journeying about in an auto. The rumble of the motor and of other cars' motors would completely mask any low frequencies, even if they could be obtained from the small loud speaker that will be put in the car. The pedestrian or dweller by the road side is already complaining about traffic noise. The din from autos that pass your house, if equipped with radio sets, would be worse than your neighbor's set which may be very loud—it usually is—but is tuned to one program. Instead you would listen to a dozen programs at once going up and down the street.

It is our opinion that the only people who will benefit by radios for automobiles are those who make—and sell—the sets. The technical difficulties of building a high-quality set for installation within the confines of the average car are almost insurmountable. The loud speaker cannot be very efficient at low frequencies because there is not sufficient space available.

If manufacturers really want a new field to conquer, let them develop cheap portable sets that can be lugged about the house, into the garden, put in the car, taken to the camp, given to the children or merely plugged into a really good loud speaker when a high degree of fidelity is desired.

The magistrates and citizens of New York City are making a determined investigation of the sources of noise in that city. Loud speakers which blat forth day or night in dealers' doorways are coming in for their share of condemnation as being against the public health and comfort. Imagine the task if half the cars that tore along had radios going full tilt to add to the din. There is still plenty for engineering departments to do to perfect present-day radio without turning them loose on a field where radio is neither needed or wanted, and where it is almost certain to become a nuisance.

Attention—

A new and more efficient type of loud speaker could revolutionize the radio industry.

Wanted—A power tube which requires only 10 mA. of B current and provides ample output.

Let's not add one-car automobile drivers to our long list of potential dangers in cities.

An efficient, inexpensive portable receiver would solve many of our problems.

THE INSIDE STORY OF THE BRUNSWICK

The six pictures on this page were taken from a booklet, "The Inside Story of Brunswick," which is published by the Brunswick-Balke-Collender Co., Chicago, Ill., to illustrate and describe the all-electric radio and Panatrophe which they manufacture. The pictures are so filled with human interest that we considered them well worth reprinting. It is hoped that they will suggest other interesting forms of advertising.

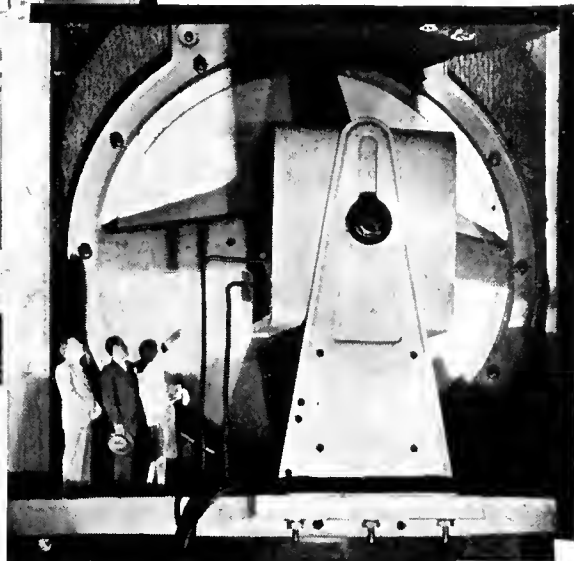
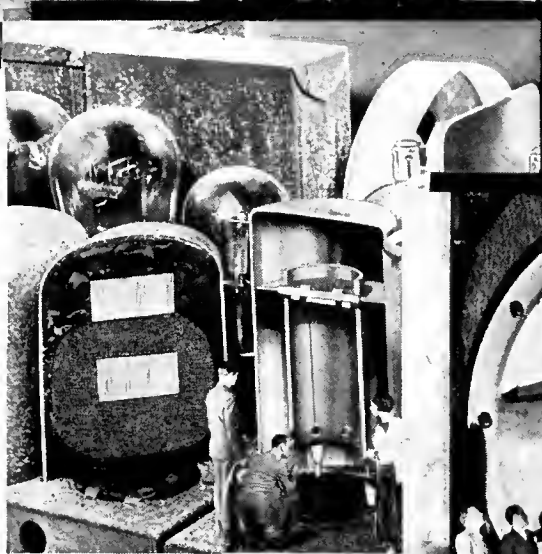
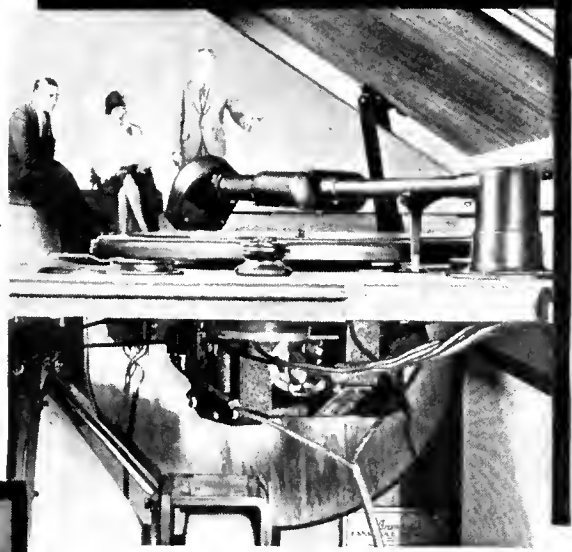

☛ Above left: "Upon entering the set the ease of operation is demonstrated; three convenient control knobs, illuminated dial."

☛ Center left: "Every part of the receiver chassis is as delicately attuned as a fine pocket watch."

☛ Below left: "Both inside and out the transformers and tuning coils of the receiver are built with absolute precision."

☛ Below right: "Vibrationless tone is assured in the Brunswick by the mounting of the super-electrodynamic loud speaker."

☛ Above right: "Careful doweling in cabinet construction prevents any possibility of warping after the set leaves the factory."

☛ Center right: "Modern electrically cut records are reproduced faultlessly with a new magnetic pick-up unit."

A New Musical Instrument for the Home

THE R. C. A. THEREMIN

THE RCA THEREMIN is a development of the Thereminvox, an invention of Professor Leon Theremin, of the Institute Physico-Technique of Leningrad. It was first demonstrated before a small and select audience of musicians and critics and soon after (January 31, 1927) before a much larger (and enthusiastic) audience at the Metropolitan Opera House.

It is a musical instrument operating entirely by electrical circuits. It has no stops, key boards, or any of the other mechanical contrivances with which musicians on other instruments must labor. The music which can be obtained from the device depends upon the operator only, and the motion of his hands with respect to two electrodes, one for controlling volume, and the other for controlling pitch. The highest tone that can be secured is about 1400 cycles which is about the limit of the average soprano or the oboe. The lowest note is some three and one half octaves below. In other words, the approximate range is from the second G below middle C to the F sharp two octaves above middle C. This is somewhat greater than the viola.

Principle of Theremin

The principle of the Theremin is that of the beat-frequency oscillator, i.e., two oscillators whose outputs are mixed and amplified. One oscillator is fixed in frequency and the other is variable by changing the capacity of the tuned circuit. This change is produced by movements of the operator's hand. An additional oscillator furnishes filament current for a UX-120 tube which acts as volume control.

The pitch-control rod is connected to a coil having a very high inductance. In addition there is connected to this coil a small condenser and a small concentrated coil. This entire circuit is tuned by the distributed capacity of its coils and resonates at approximately 172 kc. Not having any fixed capacitor connected across it for tuning, the ratio of inductance to capacitance is very high. Thus the small increase of capacity caused by the hand close to the pitch rod will cause the circuit to change its natural period considerably, a great deal more than if a large capacity and small inductance were used.

Pitch-Control Circuit

This pitch-control circuit is connected to the grid side of the variable pitch-control oscillator, the frequency of which is slightly greater than that of the pitch-control circuit. Bringing the hand close to the pitch rod will increase the parallel capacity in that circuit and thus reduce its frequency. As this capacity is reflected in the oscillator circuit a similar decrease in frequency will result in that circuit, the amount of decrease depending on the proximity of the frequency of the two circuits. Thus a greater decrease in the frequency of the oscillator circuit is obtained when the pitch-control circuit is close to the oscillator circuit in frequency than when it is at a greater frequency difference.

The fixed-pitch oscillator operates at a frequency, when correctly adjusted, at a maximum of 1400 cycles greater than the variable-pitch oscillator. The amount

of this difference is dependent on the frequency of the variable-pitch oscillator the frequency of which is determined by the position of the operator's hand in relation to the pitch-control rod. The frequency of the fixed-pitch oscillator does not change while playing.

Circuit Functions

An example of the functioning of these three circuits follows:—

The hand approaches the pitch-control



Prof. Leon Theremin demonstrating his new invention.

rod and increases the capacity across the pitch-control circuit. This capacity is reflected across the variable pitch-control oscillator and thus reduces its frequency. This causes an audible frequency difference between this oscillator and the fixed-pitch oscillator, the frequency of this note depending on the position of the hand. Bringing the hand close to the rod will increase the capacity in the pitch-control circuit, reduce the frequency of the variable-pitch oscillator, and increase the difference between the frequency of this oscillator and the fixed-pitch oscillator. Thus an audible note is obtained, the note increasing in frequency as the hand approaches the pitch-control rod.

The two oscillators are UY-227 tubes. The oscillator grids are connected to the control and screen grid respectively of a UY-224. As the screen grid has the largest area, a 10,000-ohm resistor is connected in series with it to balance the input to this tube and to make each oscillator have the same effect on the detector action. This tube is a detector or combining tube that functions much in the same manner as the first detector in a super-heterodyne

circuit. The output of the detector is then amplified by a two-stage audio-frequency amplifier using a UY-227 and a UX-171A, the output of which goes to the loud speaker.

Volume-Control System

The remaining two tubes, UX-120 and UX-171A, together with the first audio-frequency amplifier constitute the volume-control system. The UX-171A is in an oscillating circuit that operates at about 420 kc. Connected to the grid side of the oscillator is the volume-control loop circuit. This circuit resonates at a frequency below the oscillator frequency when the hand is entirely removed from the volume-control loop. This is done for two reasons. If the two circuits were in exact resonance, the load on the oscillator would be too great and operation would be unstable. Also the pick-up current would be high and might damage the tube. The ratio of inductance to capacity in this circuit is also quite high. A small pick-up coil is wound around the inductance coil of the volume-control circuit comprising a looped control rod of low capacity to frame, in series with the high-inductance primary of a r.f. transformer. This circuit resonates at a frequency below (but close to) the oscillator frequency when the hand is entirely removed from the volume-control loop. The circuits are not put in exact resonance because the load on the oscillator would be too great and operation would be unstable. The secondary winding is a small pick-up coil of few turns wound around the low end of the primary winding.

When the oscillator and hand-tuned primary circuits are nearly in resonance (hand entirely removed) sufficient radio-frequency current flows in this pick-up coil to light the filament of the UX-120 to which it is connected. When the hand approaches the volume-control loop, the natural period of its circuit is decreased in frequency, the circuit is out of resonance with the oscillator by an amount depending on the proximity of the hand, and less current flows in the pick-up coil resulting in a decreased brilliancy of the UX-120 filament.

The plate current of the first audio-frequency amplifier tube (UY-227) is fed through the UX-120. Thus if the UX-120 were at maximum brilliancy, maximum volume would be obtained. Likewise if it were not lighted, no signal output would be obtained due to the fact that amplifier-plate current would not flow.

A condenser and resistor are placed in the plate voltage supply to the first audio-frequency tube which regulates the time constant of the volume control. They are adjusted to prevent any undue lag in operation of the volume control, while preventing quick accidental variations in volume due to a slight unsteadiness of the hand. The condenser also increases the efficiency of the audio-frequency amplifier by preventing a loss of a.c. voltage across the UX-120. The low side of the resistance instead of being connected to ground is connected to a tap on the grid leak of the volume-control oscillator. This supplies a small negative potential to the plate of the first a.f. tube and insures that zero.

(Continued on page 245)

The THEREMIN IN PICTURES

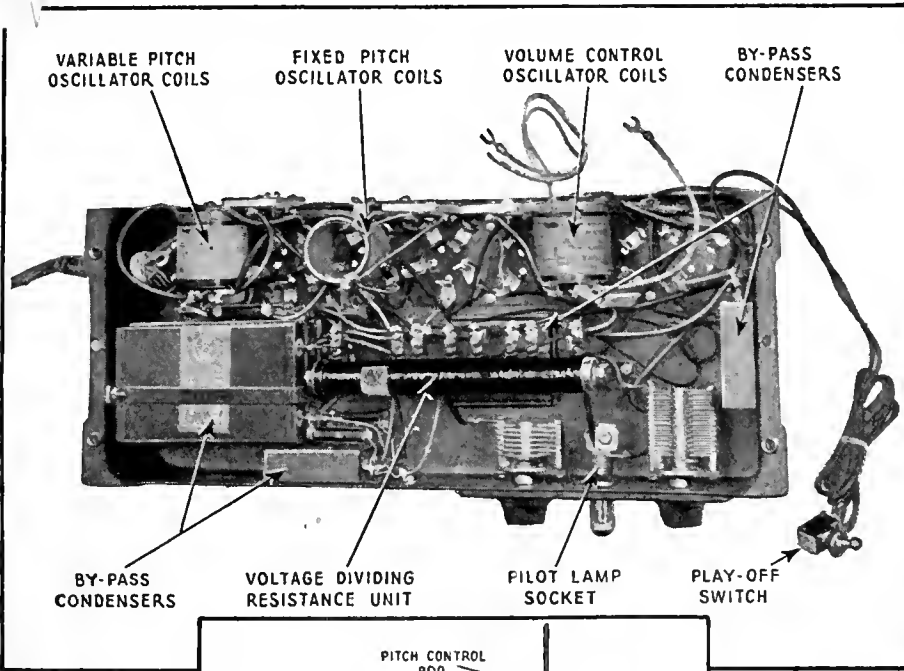

Above: The Theremin chassis as viewed below, clearly showing the wiring and location of parts.

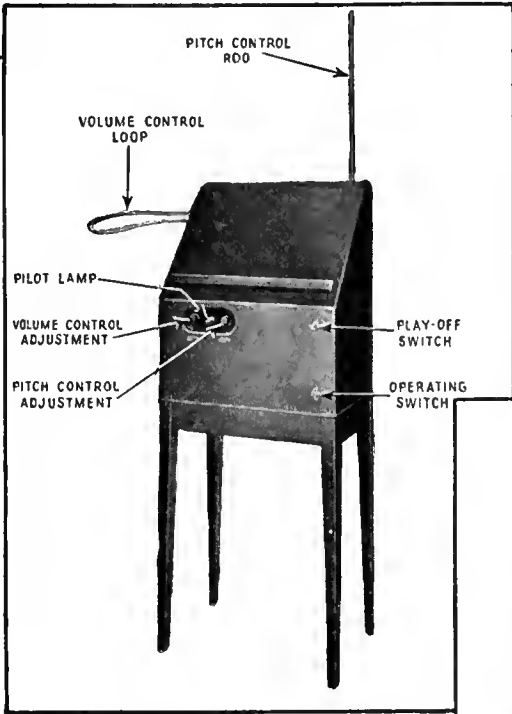

Above: View of R.C.A. Theremin with all operating controls labeled. Right: Top view of Theremin chassis. The five tube sockets are located between the coils and in front of the a.f. transformer.

Below: The location of the chassis assembly and the power supply unit is clearly shown in this rear view of the Theremin cabinet.

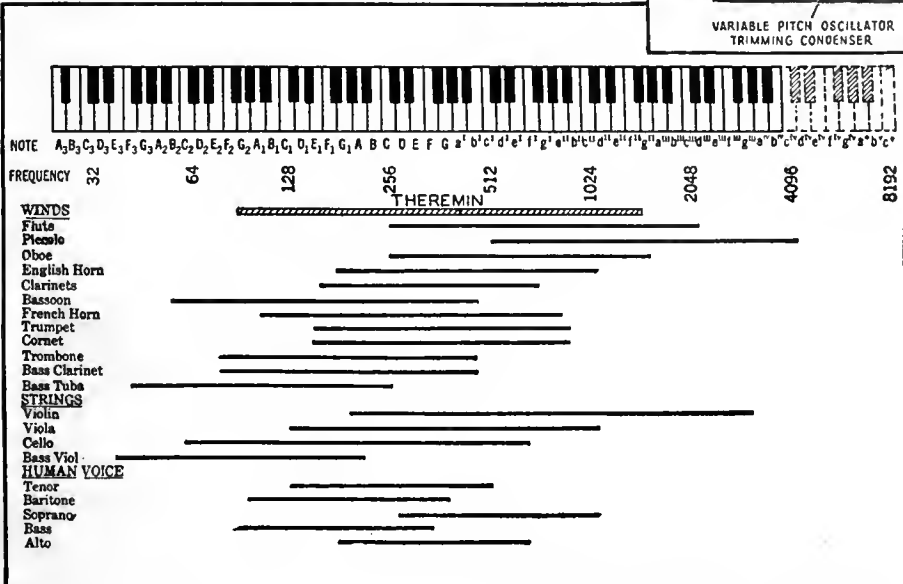
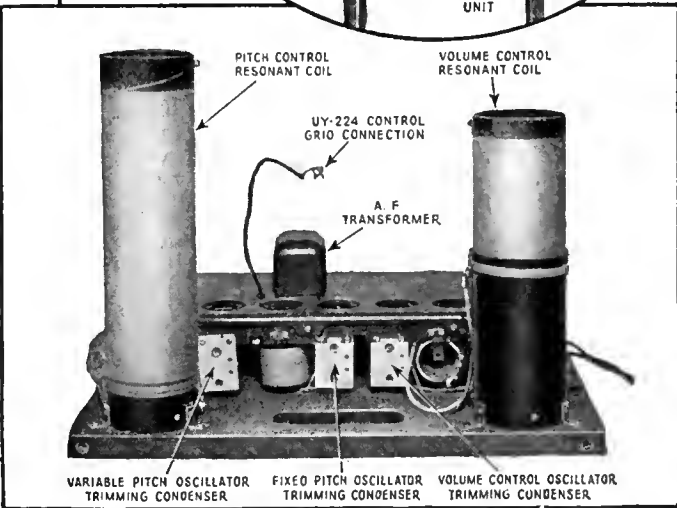
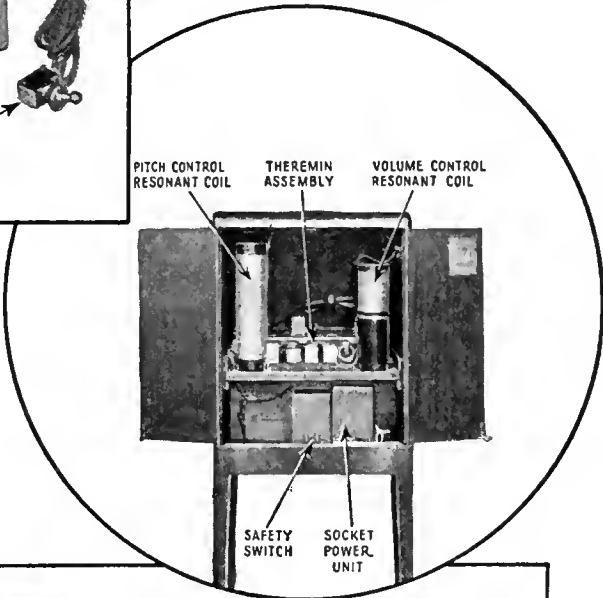

Left: The frequency range of the Theremin is indicated by the shaded line directly under the piano scale. The chart also shows how the new instrument compares in range with the human voice and other musical instruments.

Part II—Iron-Core Inductances and Transformers

A PRODUCTION TESTING SYSTEM

By J. A. CALLANAN

Stewart Warner Corporation

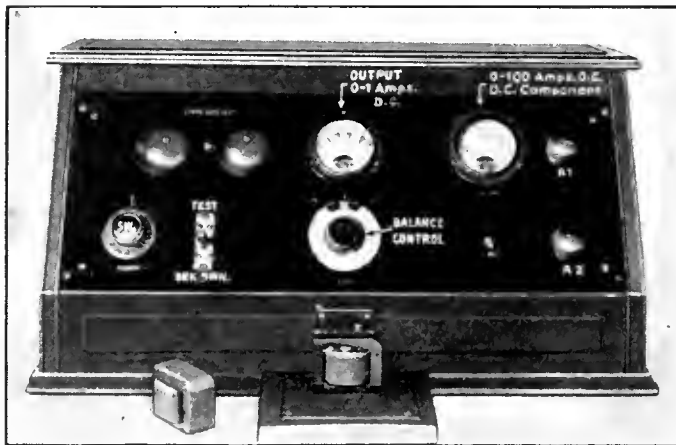

The choke coil test set.



The output transformer test set.

IN THE FIRST article of this series which appeared on page 152 of January, 1930, RADIO BROADCAST the testing of all types of condensers—compensating, variable, by-pass, filter, etc.—that are used in the construction of a broadcast receiver was considered from the viewpoint of the manufacturer's production department. In this article we will continue the discussion of production testing and various iron-core items, such as transformers, choke coils, etc., will be considered.

The testing of iron-core items may be divided into three distinct classes as follows:

- (1) The testing of power-pack transformers
- (2) The testing of audio-frequency input and output transformers
- (3) The testing of audio-frequency choke coils.

With these items it has been found that severe tests are very much worth while, the reason being that after the unit has been sealed with pitch in a container, as is the usual practice, replacing a defective part is both costly and difficult.

Power-Pack Transformers

Following the order of the above listing, the tests on power-pack coils and transformers will be considered first. These parts, upon receipt from the coil-winding department, are immediately tested for

opens and shorted turns with an ordinary continuity meter and a short-circuit-turn test set. Complete details of the shorted-turn test set are given in Fig. 1 and the apparatus is pictured on the next page.

The shorted-turn test merely consists of placing the coil over the solenoid and noting whether or not the meter deflects, deflection indicating shorted turns. Simply described, when there are no shorted turns the flux density of the two legs is equal and the potential across each coil is the same. Then, as the two circuits are bucking, there is no potential difference across the rectifier indicator circuit. However, when shorted turns are added current flows through them and generates an opposing

flux, thereby lowering the potential across the coil on one leg while that of the other remains unchanged. This causes a potential difference across the rectifier which, in turn, is indicated by the meter. The windings are not tested for number of turns as this is determined by automatic winding counters.

After the test described above has been completed the winding is assembled with the core, leads are attached and the assembly is tested by the power-pack tester shown in a picture and in Fig. 2. When the transformer leads are connected to this apparatus the primary is connected to the 110 a.c. supply through a resistor, R_1 , by throwing a switch to "test" position. The resistor used is of the order of our ballast resistor and is used rather than a ballast were used here it would tend to give identical readings for all transformers even though the winding or core were faulty.

The secondaries of the transformers are connected across loads R_2 , R_3 , etc., which simulate those of the receiver and the potential drops across them are measured with a.c. voltmeters. Switch No. 2 is used to connect the high-potential meter, V_2 , across either half of the rectifier secondary and to switch the 0-3 voltmeter, V_3 , from one 2.5-volt filament winding to the other. This scheme not only affects a

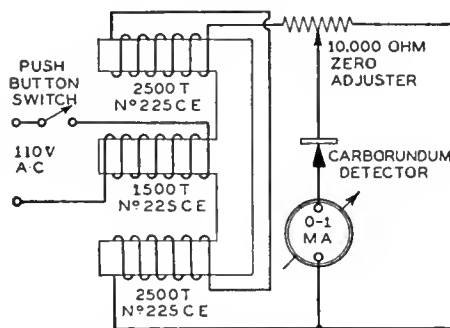

Fig. 1—Shorted-turn test circuit for output transformers.

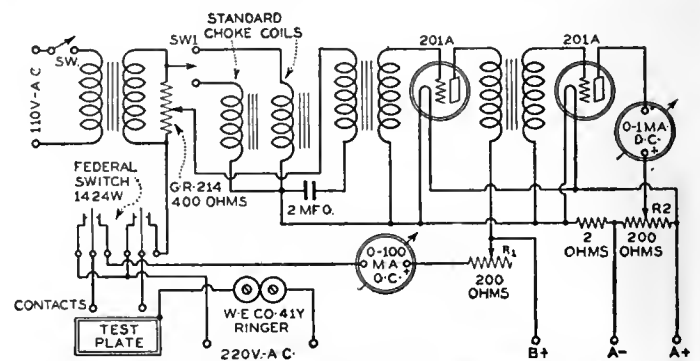
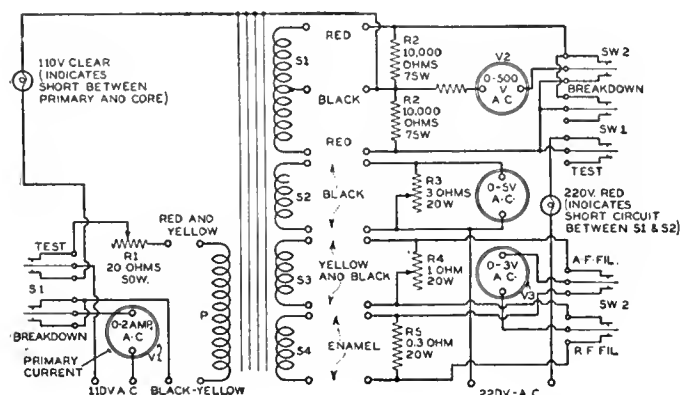

Fig. 2 (left)—Power transformer test circuit; Fig. 3 (above)—test for choke inductance.

saving of meters but also, as in the case of the rectifier winding, where the limits are less than 1 per cent., guards against possible error due to differing meters. The test limits are painted on the meter scale. When switch No. 1 is thrown to the break-down position a continuity test is made with 110 volts a.c. between the primary winding and the core, a shorted condition being indicated with a 25-watt clear lamp. At the same time a continuity test is made with 220 volts a.c. from the high-potential winding to the adjacent filament winding. In this case a shorted condition is indicated with a 220-volt 25-watt red lamp. While other break-down combinations are possible, we have as yet to experience one coil which passed this test and did not perform satisfactorily in a receiver. The design of such apparatus, however, depends upon the characteristics of the coil and the points of greatest stress; the proximity of the leads, etc., must be taken into consideration when building similar test equipment.

A. F. Transformers (Input)

Testing audio-frequency input and output transformers is a simpler matter. While we test 3 per cent. of the entire production

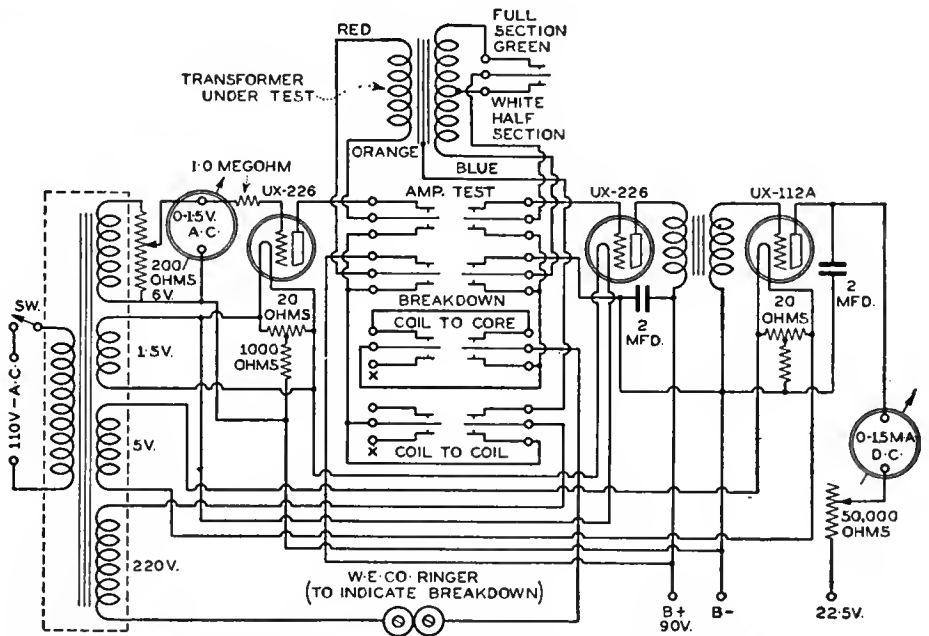

Fig. 5.—Audio-frequency input transformer test circuit.

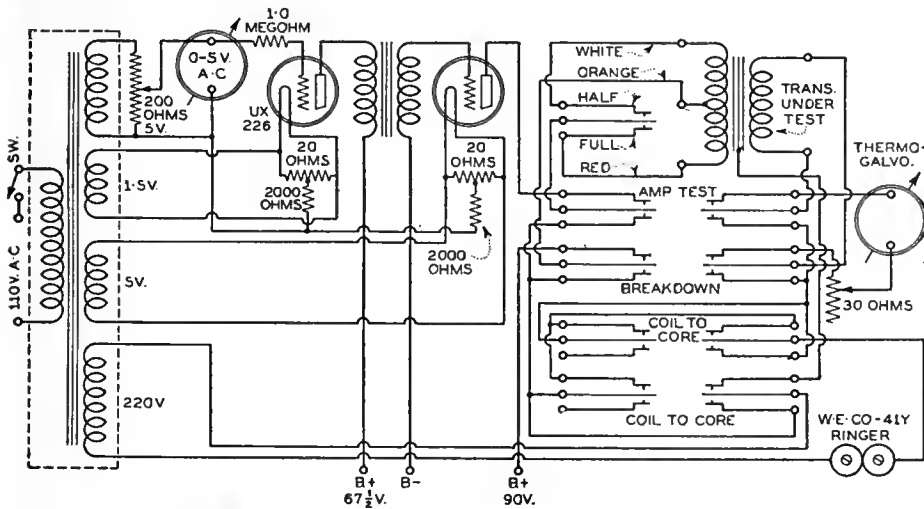

Fig. 4—Circuit for testing output transformers.

type are tested by omitting the switching. When the switch is thrown to break down, continuity at 220 volts a.c. is first made from coil to core and then from coil to coil, with the aid of a third switch as shown in the diagram and picture. Adjustment of the input potential is made with the 200-ohm potentiometer while the sensitivity of the V.T.V.M. is controlled with a 50,000-ohm resistor connected in the plate lead of the tube. The circuit is shown in Fig. 5.

Output Transformers

The output transformer test fixture is very similar to the input as can be seen by reference to Fig. 4. It differs only in that a larger a.c. input is used and that the output is connected to a thermo-galvanometer rather than a V.T.V.M. as the load is more nearly correct. In this case we first test one half of the primary and then the other. The input potential is controlled by a 200-ohm potentiometer and the galvanometer reading by a 30-ohm rheostat. The filament and break-down potential of both these machines are obtained from a.c. lines while the B supply is from
(Continued on page 243)

at three frequencies, 60, 500, and 5000 cycles, the production test is made with 60-cycle supply and conducted in the following manner.

Upon receipt of the coils they are tested

for shorted turns, break-down between windings, and the number of turns. This is accomplished in one operation by placing the coil on a partial core, connecting the primary to the output of a bell-ringing transformer, and connecting the secondary to a vacuum-tube voltmeter. Spring clips make the connecting quick and positive. The deflection of the V.T.V.M. indicates whether or not the coil has been correctly wound while a possible short between primary and secondary is indicated by a 45-volt B battery and a meter connected between the low sides of these windings. After the assembly has been completed the transformers are placed on one of two conveyors, depending upon whether they are input or output transformers. The conveyors take the units to the test fixture shown in Figs. 4 and 5 and the accompanying pictures. The input transformer test fixture tests the circuit by connecting it between two tubes and measuring its gain at 60 cycles with a V.T.V.M. The transformer is placed in the jig and the leads are connected to spring clips. When the switch is thrown to test position one half of the secondary is first connected and then the whole secondary. The reader would no doubt expect that each half would be tested, but we have found coils in which one half the secondary was bucking the other half so the above method was selected.

Coils which are not of the push-pull

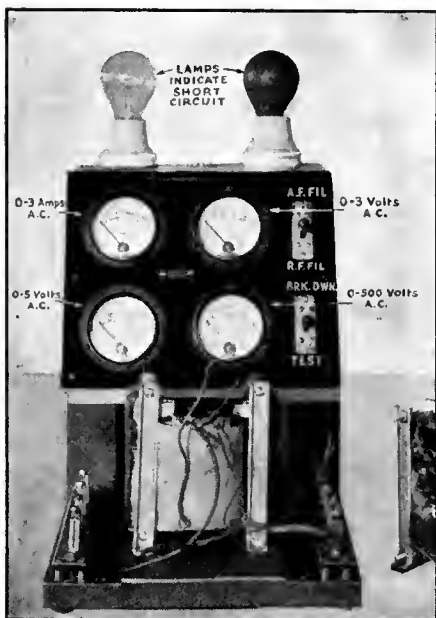

Power-pack transformer test set.

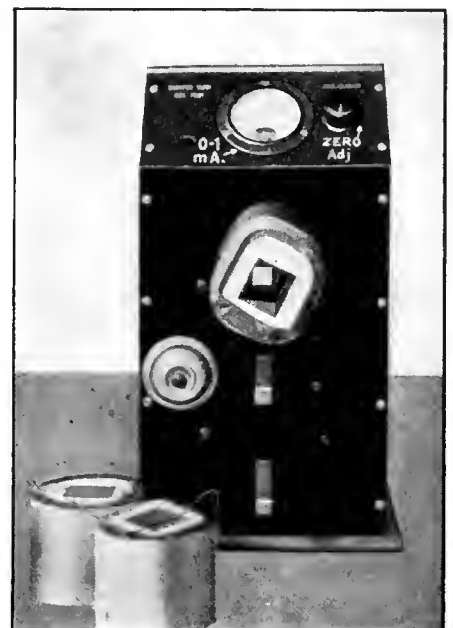

The shorted-turn coil tester.

An Installation For Apartment Houses

THE MULTICOUPLER ANTENNA SYSTEM

By ERNEST V. AMY and J. G. ACEVES

Amy, Aceves, and King, Inc.

NO LONGER need committees of civic beautification rack their brains to find ways and means of ridding the housetops and apartment house roofs of their maze of unsightly poles, antennas, wires, and cables. The multicoupler antenna system, a group antenna for the operation of from 1 to 15 radio receivers, is both slightly and simple. It makes use of a small coupling device between the common antenna and each radio set, requiring no additional equipment or pre-amplification.

The system comprises a pick-up device, such as an antenna, preferably mounted on the roof of the building, and a lead-in conductor passing from floor to floor and, if desired, to a plurality of locations on one floor. A number of radio sets are coupled to the lead-in by running the antenna connection of each receiver to the binding post on a device called the multicoupler, which is a combination of inductance and capacity enclosed in a bakelite cylinder some six inches long. These multicouplers are inserted in the lead-in, one for each radio set to be operated. The antenna connection of the radio receiver goes to a condenser in the multicoupler, which in turn goes to the center of two loading coils interposed in the lead-in conductor between the various receivers. The values of the condensers and loading coils are chosen so that the lead-in conductor and apparatus attached to it will act like a loaded transmission line, the upper frequency of

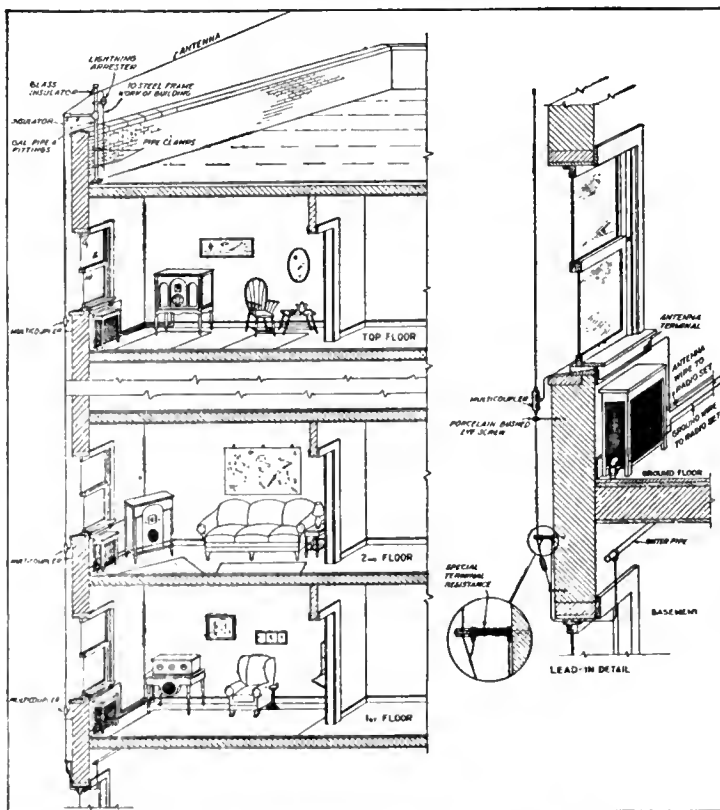

Showing how the multicoupler system is installed in an apartment house.

which is equal to $\frac{1}{\sqrt{LC}}$. The intermediate

loading coils all have substantially equal inductance, while the initial and final loading coils have an inductance equal to one half that of the intermediates. (Figs. 1 and 2).

To prevent standing waves on the trans-

mission line, the end of the line or lead-in is grounded through a resistance, approximating the line surge impedance, that is, $R = \sqrt{L/C}$. We have found that very satisfactory results are obtained when the intermediate loading coils have inductances of 80 microhenrys, the initial and final loading coils have 40 microhenrys, the coupling condensers for the various receivers have capacities of 250 mmfd., and the terminal resistors have a value of from 500 to 1000 ohms. Under such conditions the transmission line will pass frequencies as high as 1600 kilocycles.

The insertion of the radio receiver in series with the coupling condenser will change the value of the reactance as well as the reactance of the shunt element at that point. But it is desirable that this change be so small that the effect on the other receivers will not be greater than the interaction present were each receiver connected to its own antenna.

In order to determine the reaction of a number of typical radio sets upon the properties of the loaded line to which they were connected, a number of tests were made which are herein classified under three main headings: First, when the sets were not connected to the line and the condensers (C in Fig. 3) grounded; second, with all the sets connected to the line but not tuned to the same frequency; third, the same measurements repeated with the sets all tuned to the same frequency.

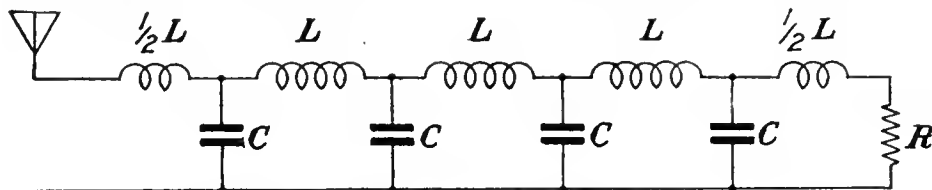

Fig. 1—Circuit arrangement in test where coupling condensers C are grounded and transmission line is terminated in resistor R

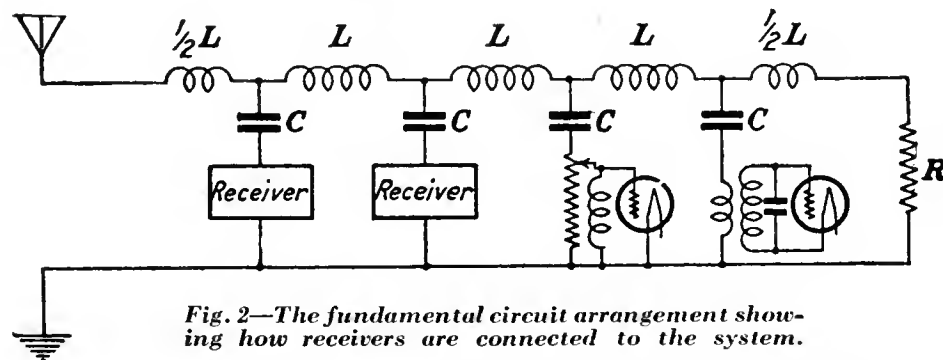

Fig. 2—The fundamental circuit arrangement showing how receivers are connected to the system.

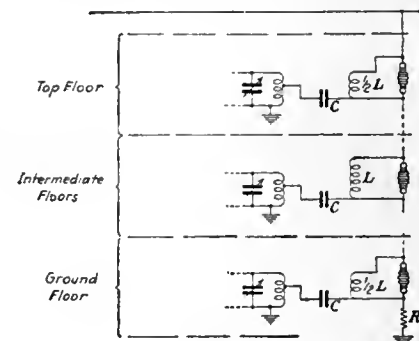

Fig. 3

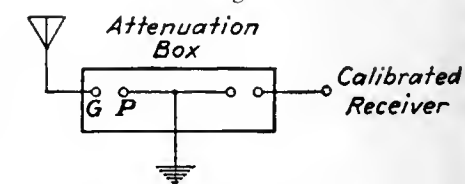

Fig. 4—Connections to the attenuator used in calibrating the apparatus.

Since the tuning of one set may affect the rest of the line when the resonance point is just reached, some tests were also made with all sets except the one under observation slightly detuned, first to a higher and then to a lower frequency. A second series of tests was made, to determine the effective resistance and reactance of typical tuned input circuits such as are used in the average commercial radio receiver. Following this, a third series of experiments was conducted to measure terminal impedance of the loaded transmission line with different values of terminating resistances, to show whether or not the line acts as a uniformly loaded conductor with minimum terminal reflection. Briefly, then, these tests may be classed as; first, e.m.f. measurements under various conditions along the loaded line; second, effective constants of typical tuners; third, effective constants of the loaded line.

First Series of Tests

In the first series of tests the receivers were located at the second, third, fourth, fifth, and sixth floors of the building, the terminating resistance being located at the ground floor. The lead-in came down the side of the building with a glass insulator inserted at each floor, leads being run from either side of the insulators through the windows to the rooms where the coupling condensers and tuner units were located, as illustrated in Fig. 3. Each tuner consisted of an auto-transformer, tuned by means of a variable condenser of 500 mmfd. The auto-transformer inductance contained about 50 turns in the secondary circuit and five to eight turns in the primary circuit.

A portable receiving set (see Fig. 5) with a volume control calibrated in db and an indicating instrument acting as volume indicator was built for these tests. The receiver was carried to all floors and connected in place of the tuner unit. It will be noted that in the circuit of this receiver, Fig. 5, the input contains a series resistance which makes the input impedance almost constant for all wavelengths. It was adjusted at approximately 600 ohms. The primary of the first tuning transformer was in the form of a tickler coil, the controlling

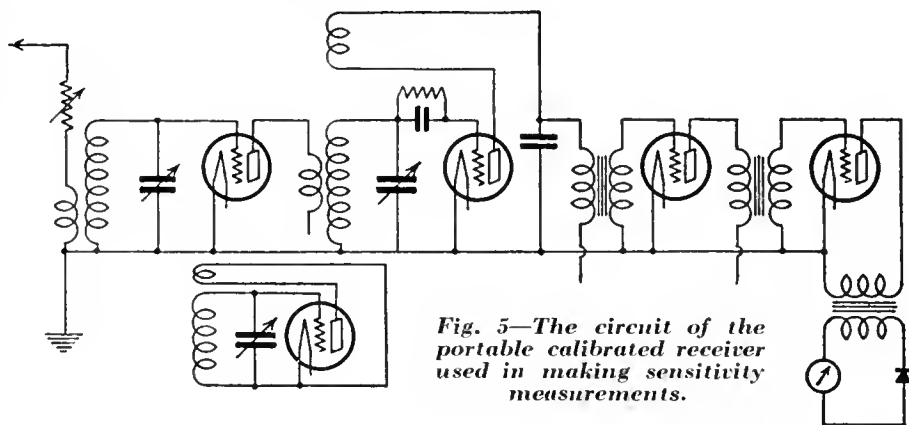

Fig. 5—The circuit of the portable calibrated receiver used in making sensitivity measurements.

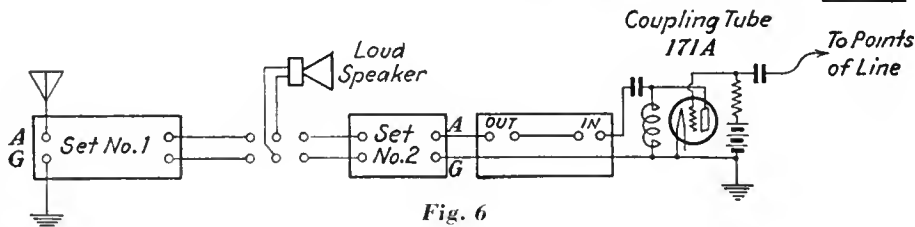

Fig. 6

knob of which was located outside of the box and had a scale calibrated in db. The calibration was obtained by means of a G.R. attenuation box connected between antenna and input circuit, as shown in Fig. 4. By reducing or increasing the number of db in the box, the scale of the volume control was determined, while

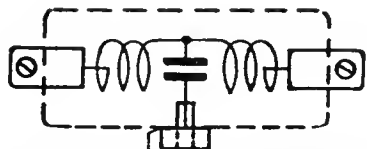

Fig. 9—Fundamental circuit arrangement of a multicoupler.

keeping the reading of the volume-indicating instrument constant.

In order to avoid fluctuations of the meter with the modulations of the broadcast program, the measurements were made with the carrier wave. An auxiliary oscillator was provided so that the resultant audio-frequency beat was impressed upon the volume-indicating galvanometer

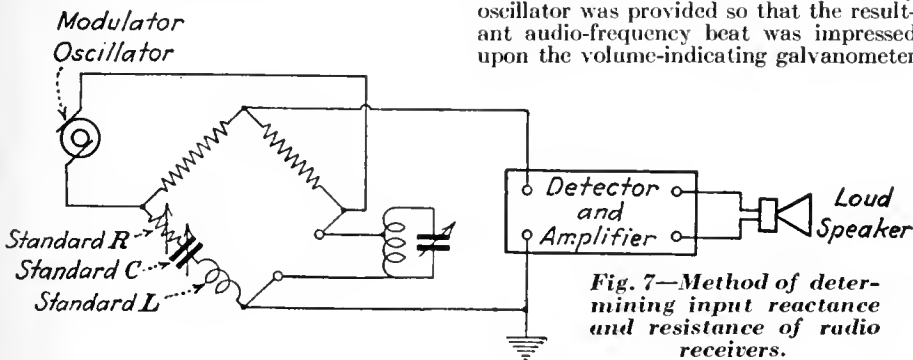

Fig. 7—Method of determining input reactance and resistance of radio receivers.

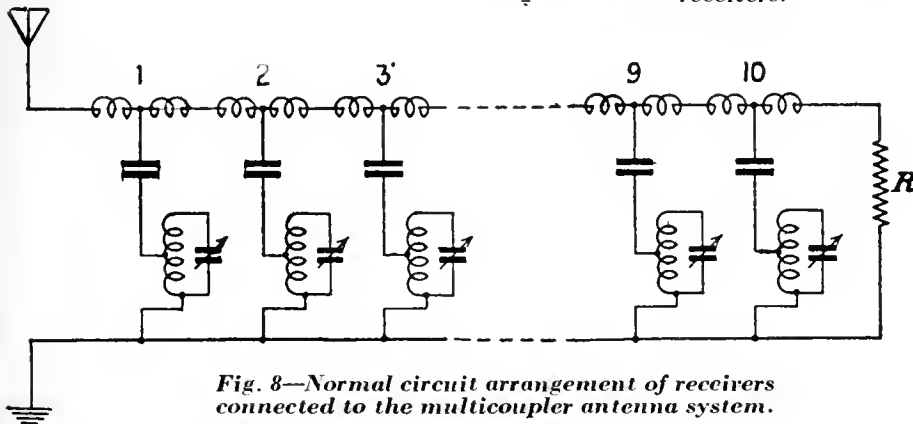

Fig. 8—Normal circuit arrangement of receivers connected to the multicoupler antenna system.

(with rectifying crystal in series) and the pitch of that note was kept constant throughout the tests. A second volume control was provided in the regenerative detector to produce a suitable deflection in the meter from very weak signals. The calibration of this control was achieved in the same manner as that of volume control No. 1, but was slightly different for the various wavelengths. The sum of the two readings of the volume controls gave an arbitrary "level" for any particular broadcast station, the measurements showing only differences in level.

Conditions of Test

Tests were conducted with all the sets disconnected, then with all the sets tuned to a given station, and finally with all the sets detuned by a very small amount. Following these tests, the terminating resistances were varied and the tests repeated. It was found that with a 750-ohm terminating resistance, and coupling condensers in the multicouplers of 500 mmfd., there was a sufficient degree of freedom from interference for all the low-frequency broadcasting stations, but not quite enough for those high ones above 1000 kc.

It was realized that by applying the loaded line to sets on the same floor, the action of the short vertical wires connecting two consecutive floors might help the signal transmission. It was decided to try the same experiments with all the tuners in the same room, and the loaded line located therein and supplied from an antenna on the roof above the sixth floor. The tests were made in the laboratory on the third floor. This would considerably simplify the problem of measuring voltage distribution, since it would eliminate the necessity of carrying the portable receiver to each floor and making innumerable re-calibrations. Also, the results could be obtained directly in terms of the G.R. attenuation box, without calibrating the radio set controls. To this end, two radio sets were used; one fed from an independent antenna and the other from a coupling tube through the attenuation box, as shown in Fig. 6.

First, the two sets were tuned to a given station and the volumes equalized by throwing the loud speaker from one set to the other while manipulating the attenuation box for equal intensity. With the free grid terminal of the coupling tube, set No. 2 could be connected to any point in the loaded line. By connecting the free

terminal of the coupling tube to the secondary of the tuners, resonance was obtained in these circuits for any desired station. In later tests a local oscillator, modulated with a 1100-cycle audio frequency, was used instead of the regular broadcasting station. An a.c. instrument with a suitable step-down transformer was connected in place of the loud speaker, or in multiple with it, and its indications registered the volume within less than $\frac{1}{2}$ db. There being no longer any need for set No. 1, it was

up a practical case, a standard commercial radio receiver—a Kolster d.c. set—was selected and measurements were made of the effective resistance of the input of that set at various frequencies when the set was sharply tuned to each particular frequency. In each instance, by definition, the reactance was zero and the resistance assumed the values shown in Fig. 13, where the dotted line represents the effective resistance of the input of the set when tuned to each of the frequencies given by the abscissae. The line in full gives the reactance of a 250-mmfd. condenser at the same frequencies. It will be noted that they are not very much different from each other, and consequently the effect would be that of condenser with a leakage having the same admittance as the condenser, or a 45-degree phase circuit with most unfavorable conditions. When sets with tuned input circuits are connected to the loaded line, it may be expected that the adjustment of one of them may alter the signal energy level at the input of the others to some extent. Therefore, in order

this set was tuned nearer and nearer to the frequency of the supplied e.m.f. and the attenuation box was correspondingly adjusted so that the indicated volume in the V.T. voltmeter remained the same.

Detuning Effects

The readings of the attenuation box showed the effect upon the volume of set C caused by the tuning and detuning of set D. The results are shown graphically in Fig. 12 where the line in full represents energy gains or losses in db over an arbitrary level, versus scale divisions of the tuning equipment of set D. It will be noted that the maximum deviation from normal does not exceed ten db, which is about as much reaction as has been found to exist between parallel tuning antennas in, say, a six-story building. However, this amount seemed too much for good performance, and it was reduced materially by the insertion of a series resistor in the antenna connection to the interfering set D at point F (See Fig. 14). The dotted lines in Fig. 12 show the effect of resistors of 1000 and 1500 ohms, respectively, upon the amount of interference of set D upon sets C, and, by inspection, it will be seen that it was cut down to 3 db maximum deviation from normal volume. The insertion of the 1000- and 1500-ohm resistors reduced the sensitivity of the interfering set D by 5 and 6 db, respectively, which is a very small amount. The replacement of individual antenna wires, as a rule badly installed, by a good receiving antenna, will more than bring back the energy level lost due to the insertion of these resistors in isolated cases, where special radio sets need them.

The difference in db level between the various sets from beginning to end is given in the accompanying tables. It will be noted that the line acts almost perfectly whenever the sets are not tuned to exact resonance. When only half of them are tuned to one station and the other half detuned, there is a negligible amount of interference, even in the high-frequency end of the broadcast band. The tables refer to the normal circuit arrangement as indicated in Fig. 8. The terminal resistor R was 500 ohms and the tests were made with the local oscillator modulated at 1100 cycles.

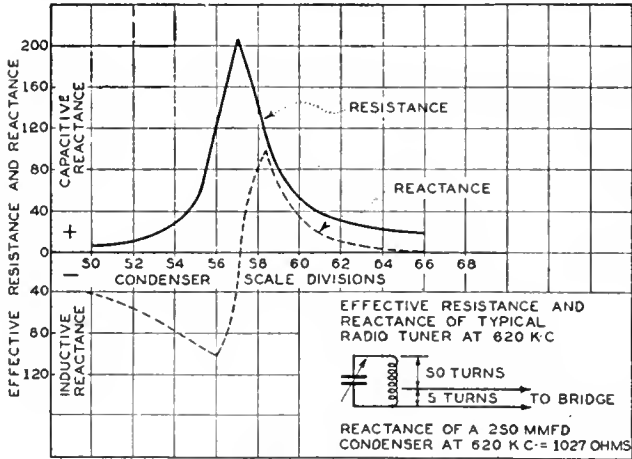

Fig. 10

dispensed with since the input frequency remained constant.

Tests were conducted to determine the performance of the tuners when the condenser was varied, to see whether the effective impedance of the combination was small enough in comparison with the reactance of the coupling condensers of the loaded line. For this purpose the primary of one of the tuners was connected to an a.c. Wheatstone Bridge, as shown in Fig. 7. The bridge was balanced for various positions of the dial of the tuning condenser. Figs. 10, 11, and 13 show the results in graphic form.

Resistance vs Reactance

It will be noted that the effective resistance and reactance of the tuner, as it appears from the primary side, is used as ordinates, while the abscissae represent scale divisions in the tuning condenser. The condenser is of the straight-line-capacity type. At 620 kc., Fig. 10, the resistance is a maximum at 57.2 divisions and reaches a value of 200 ohms; at the same position, the reactance is zero. The maxima of the reactance were 100 ohms and occurred at 56 and 58.5 divisions, almost symmetrically located with respect to the zero reactance point. As the reactance of a 250-mmfd. condenser at 620 kc. is 1027 ohms, it will be seen that the effect of the tuner in series with the condenser of the loaded line, Fig. 10, is negligibly small at all values of the condenser in the tuner of a typical radio receiver.

Fig. 11 shows exactly the same relations that Fig. 10 indicates, but at 1100 kc. instead of 620. It will be noted that the effect is more pronounced at this frequency as might be expected from theoretical considerations. However, the maxima of the reactance, which occur at 16.2 and 15.8 scale divisions, reach a peak of 265 ohms which is smaller than the reactance of the coupling condenser of 250 mmfd., namely, 579 ohms. The effective resistance at 16 scale divisions is fairly large—730 ohms—but in practice it would require a considerable number of sets, all tuned to receive a station operating on 1100 kc. to produce an undesirable amount of interference with each other. In order to take

to determine how much reaction a set of this type will produce in the energy distribution of the line, a test was made as follows: A set with a tuned input circuit (without series condenser other than the one at the multi-coupler) was connected to the loaded line, and another set of any character at another point of the same line. The volume of the output of the second set was determined for various positions of the tuning condenser of the first set as shown in Fig. 14, where A is a modulated oscillator supplying the antenna system with r.f. energy through an attenuation box B graduated in db. The output of set C, the performance of which may be influenced by adjustments made on set D, is to be studied, measurements being made by means of a V.T. voltmeter, E. A certain arbitrary level was chosen to start with, and the set under test was tuned to the particular frequency of the modulated r.f. supply, with set D far out of tune or disconnected from the line. Then

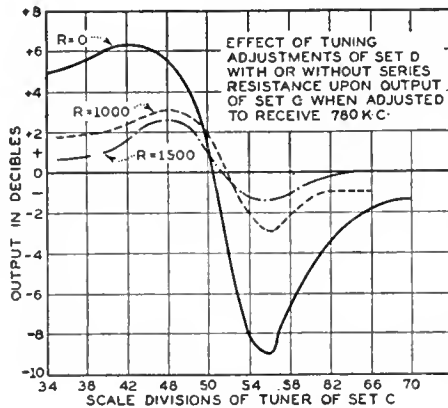

Fig. 12

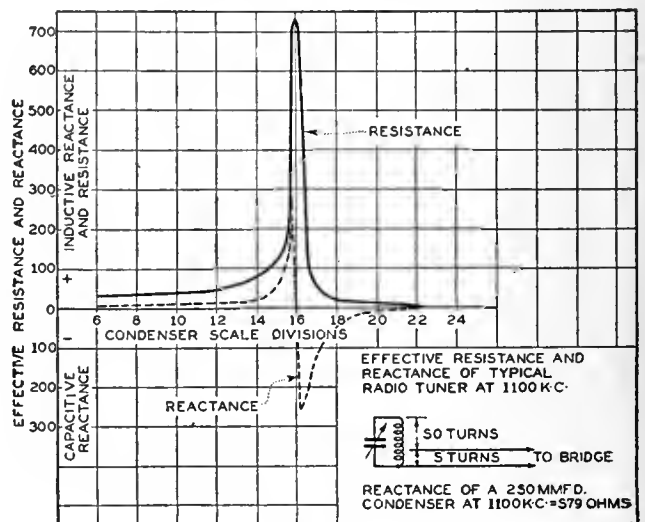

Fig. 11

It will be noticed that the level changes from point to point. The variation is quite tolerable and the departure from the average value is smaller than the coupling effect of two antennas running side by side, six feet apart, namely 10 db.

The figures given in these tables represent arbitrary levels and were obtained as

Table I

STATION WOV, 1130 KC.		Condition of tuners		
Point in Fig. 8.	Short circuited	Tuned to WOV	Detuned + 1	Detuned - 1
1	33	28	33.5	30
2	32	27	33	30.5
3	31	18	31	30
4	31	16.5	31	28
5	33	16	33.5	31
6	33	11	33	27
7	27	2.5	27	27
8	27.5	6	27.5	28.5
9	26.5	4	26.5	27
10	25.5	1	25.5	27.5
R	26.5	1/2	26.5	28

Table II

STATION WABC, 860 KC.		Condition of tuners		
Point in Fig. 8	Short circuited	Tuned to WABC	Detuned + 1	Detuned - 1
1	29.5	28	30	29.5
2	29	27	29.5	29
3	29	24	29	28
4	29.5	21	29	28.5
5	29	21	28	29
6	29	18	27	29
7	29	17	25.5	29
8	29	15.5	26	28.5
9	29	12	24.5	27
10	30	10.5	22	26.5
R	30	10	22	27

follows; first, the oscillator was very loosely coupled to the antenna lead-in and the radio set carefully tuned to the impressed frequency, while the volume control was adjusted so as to be far above noise level, but sufficiently low to permit the detector to act under normal conditions. A certain value of dB. was inserted in the attenuation box to obtain sufficient margin on each side. After that, the lead connecting the free grid of the 171A coupling tube (Fig. 6) was made to touch the various points in the line, with all the tuners short-circuited and the figures of the first column of the tables were obtained. Then all the tuners were inserted as in Fig. 8, with the grid wire attached to the non-grounded end of the primary of the tuning coils. The tuning condenser was adjusted to resonance by listening in on the test set for maximum response. After the tuners were adjusted the grid wire was again touched to each point of the line, as before, and the figures of the second column were obtained. By detuning the various condensers of the tuners by 1 or -1 condenser scale division, and repeating the process of measuring the levels at the various points of the line, the figures in the third and fourth columns of Tables I,

seriously considered. A subsequent test was made, however, in which the odd numbered sets were tuned and the even numbered ones tuned away, from a particular station. Thus, No. 1 was tuned to wov, No. 2 detuned, No. 3 tuned to wov, No. 4 detuned, etc. The results of this test are shown in Table IV.

We conducted one final test to determine if the transmission line acts as a true infinite line when the terminating resistance has a suitable value. To accomplish this, Wheatstone Bridge measurements of terminal impedance were taken and graphs plotted from the calculated results. The results are shown in Table 5, which gives the values of effective resistance of the loaded line terminated in a 600-ohm resistor. This is shown graphically in Fig. 15.

The results of the investigations described warranted the application of the loaded supply line to commercial installa-

mutual induction did not affect the operation of the system, there being no difference in performance between separate coils or coils of half the same inductance, placed close together, so that the effective

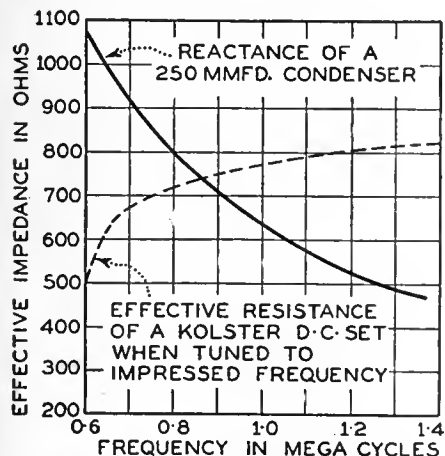

Fig. 13—Input impedance characteristic of Kolster receiver.

II, and III were obtained. It will be noted in Tables I, II, and III, that the loaded line performs very satisfactorily except when all the sets are tuned to the same short wavelength station. But this is such a rare occurrence that it need not be

Table III

STATION WMCA, 570 KC.		Condition of tuners		
Point in Fig. 8	Short circuited	Tuned to WMCA	Detuned + 1	Detuned - 1
1	21	19	19	20
2	21	18	19	20
3	21	17	18.5	20.5
4	20	17	18	20
5	19	16	17	18.5
6	19	14.5	17	19
7	21	14	17	20
8	21	12	17	18.5
9	20	10	15	18
10	19	7.5	14	18.5
R	19	10	14	19

Frequency in kc.	600	700	800	900	1000	1100	1200
Effective Resistance	635	526	452	418	400	385	370
Effective Reactance	Negligible at all frequencies						

Table IV

Point in Fig. 8	All sets de.uned	Every other set tuned to WOV, 1130 k.c.
1	33	38
2	32	37
3	31	28
4	32	31
5	32	29
6	31	24.5
7	32	22
8	32	22
9	32	22
10	33	22.5
R	33	23

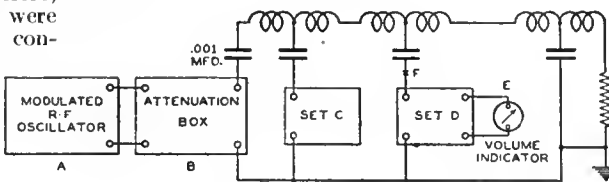

Fig. 14—Method of determining amount of interaction between receivers.

tions, and, to that end, suitable units, known as "multicouplers" were designed. With the idea of simplifying the construction and installation of these units, instead of employing a coil of half the inductance at the beginning and end of the line, as outlined in the theory of operation, a universal "T" unit was devised. It consists of two coils of 40 microhenrys each, with a 250-mmfd. condenser connected to the mid-point, enclosed in a bakelite cylinder for outdoor as well as indoor installation. Fig. 9 shows the circuit as well as the outside appearance of the multicoupler.

Tests covering the same properties of transmission, impedance, etc., were made with the completed units in which the two coils of the "T" filter together had the required 80 microhenry inductance, with a certain amount of mutual induction included. It was found that the presence of

total value would be 80 microhenrys.

With the construction of the antenna couplers standardized, many practical applications will suggest themselves. Installations made in New York City are proving more than satisfactory. We consider this a truly practical solution to the apartment house congested-antenna problem.

In conclusion a few words regarding the sale of multicoupler systems may be of interest. Newly erected apartments offer the easiest market for sales. These buildings, being new, the owners must offer every modern convenience. In Greater New York and New Jersey estimates are made upon request and submitted after a general survey of the building, including a careful inspection of the roof and floor plans to determine the number and location of down leads and associated aerials. Price per outlet is the form usually used in submitting quotations, and the length of the inside runs and where the owner wants the lead-in to terminate govern to a great extent the amount of the cost. The average cost for an installation of about fifty outlets is \$15.00 per outlet, but the cost may be as low as \$10.00 per outlet or as high as \$25.00. Out of town, a multicoupler system complete with plans and specifications is sold to electrical contractors and radio companies who have an adequate force to do this type of work.

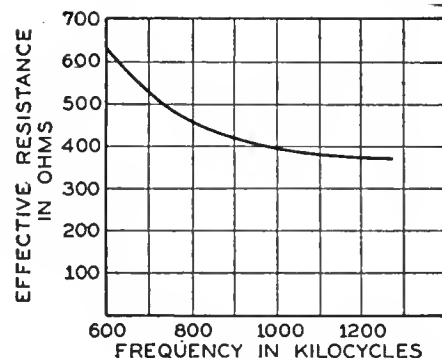

Fig. 15—Effective resistance of the loaded line terminated in a 600-ohm resistor.

A New Trend in Radio Kit Design

THE 1930 MODEL HI-Q RECEIVER

By CURTIS W. HAMILTON

Hammarlund-Roberts, Inc.

THE MANUFACTURE and sale of kit receivers have seen a gradual change from the old days when a circuit was designed, the parts of half a dozen different manufacturers specified in a construction article, and the radio-constructor invited to go to the corner radio store and purchase them. To-day the kit manufacturer designs a circuit, and puts all the units into a single box together with complete assembling data and operating instructions—and, further, the kit manufacturer now goes to considerable effort to design complete tested units so that the construction of a kit becomes, not a matter of assembling a large number of individual parts, but rather that of wiring together a few major units. This practice has been followed by Hammarlund-Roberts, Incorporated, in the design of the Hi-Q receiver. All of the major units required for the assembly of the receiver are received by the constructor completely wired and carefully tested.

Eight Features

Eight major features stand out in the new 1930 model of the Hi-Q receiver. They are as follows:

- (a) A three-stage band-pass selector preceding the first screen-grid r.f. amplifier tube. This gives high selectivity and prevents cross talk.
- (b) A three-stage, screen-grid, radio-frequency amplifier using screen-grid tubes coupled by tuned r.f. transformers.
- (c) Single-control tuning. All of the six variable condensers of the receiver are controlled by the single tuning



The Hi-Q 30 mounted in an attractive console cabinet.

dial. The only other control is for the volume. The volume control uses a potentiometer arrangement to vary the screen-grid voltage of the first and second r.f. amplifiers.

(d) A grid leak-condenser type detector of high sensitivity. The detector is coupled to only part of the tuned circuit feeding it so as to compensate the differences in impedance between the input circuit of the tube and the impedance of the tuned circuit.

(e) Complete shielding of the tuned circuits composing the pre-selector unit and the tuned circuits coupling the r.f. amplifier tubes.

(f) Filter circuits consisting of r.f. choke coils and by-pass condensers in the plate circuits of all the r.f. amplifier tubes. Filtering of the supply to the screen grids of these tubes is by means of series resistors and by-pass condensers.

(g) A two-stage, transformer-coupled a.f. amplifier using a 227-type tube in the first stage and two 245-type tubes in push pull in the output.

(h) A phonograph-radio switch which, when closed, connects the pick-up unit to the grid circuit of the detector.

The Band-Pass Filter

The most important feature of the Hi-Q 30 is, probably the band-pass filter connected ahead of the first r.f. amplifier. It is a characteristic of the screen-grid tube that it can handle but comparatively small input voltages before it begins to overload and produce "cross talk" so that a powerful local station is heard when listening to a weaker station. One solution of

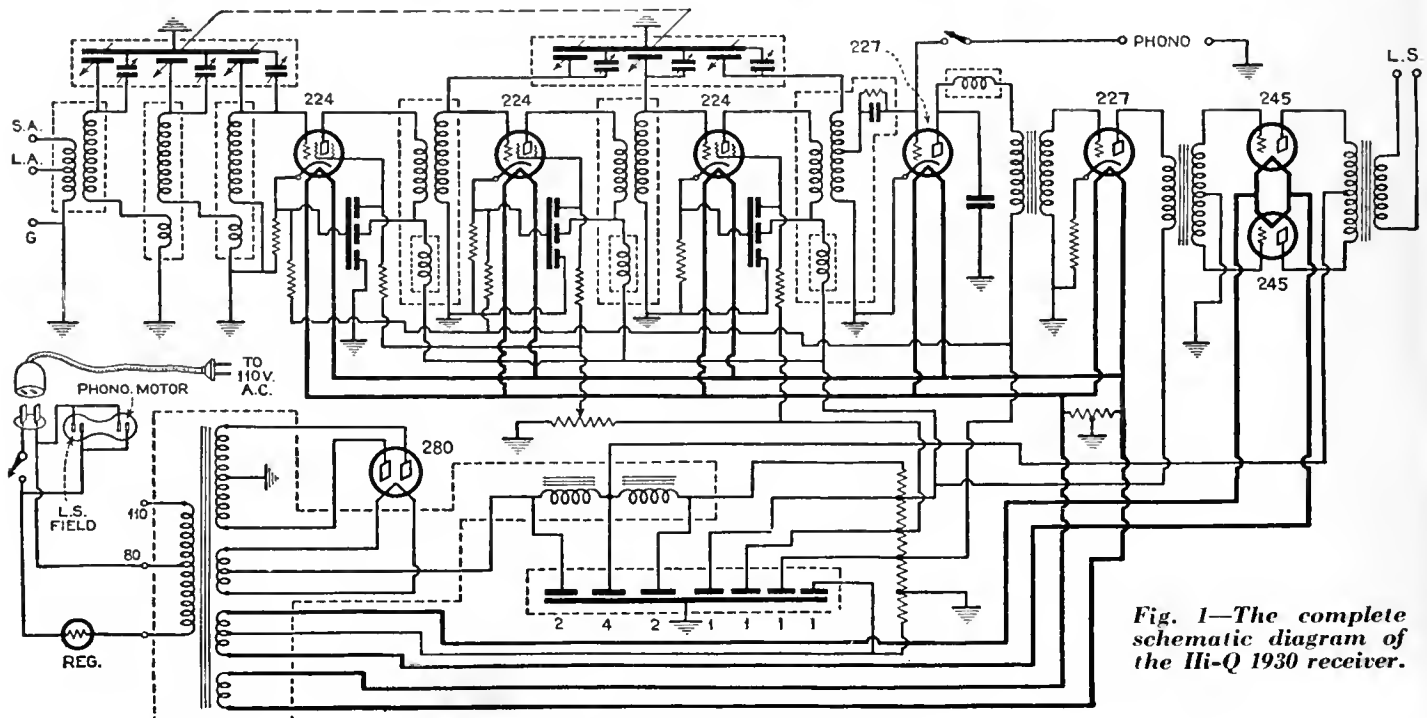
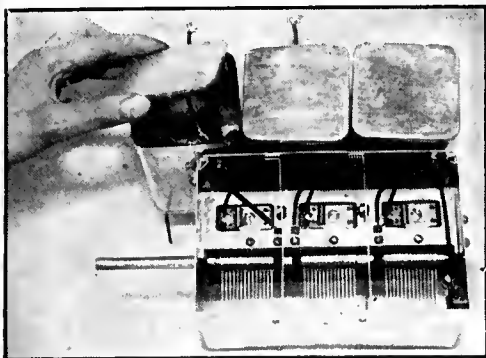
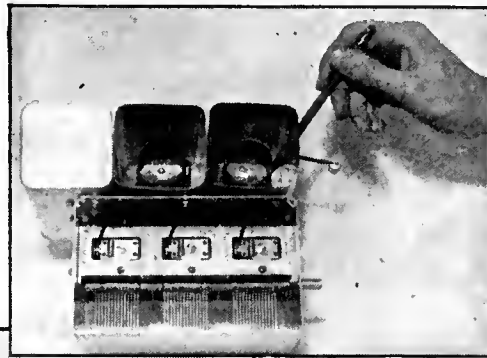

Fig. 1—The complete schematic diagram of the Hi-Q 1930 receiver.



The picture below shows the chassis of the Hi-Q 30 as viewed from above. All shields are in place and the important parts are labeled. On the left is a close-up view of the r.f. amplifier unit and on the right is shown the pre-selector unit.



this difficulty is to incorporate sufficient selectivity in the receiver between the antenna circuit and the first r.f. amplifier tube so that all signals but the desired one are reduced in strength to a point where they cannot produce "cross talk"—and this is the function of the band-pass filter in the Hi-Q 30, i.e., the band-pass system is used to give the selectivity necessary ahead of the first 224 tube to prevent "cross talk." The required selectivity might have been obtained by the use of ordinary tuned circuits, but, then the side-band suppression would have been greater. In a sense, therefore, we can consider the r.f. circuits as being composed of two parts; first the pre-selector circuit functioning to reduce undesired signals as much as possible, thereby preventing "cross talk," and second the following tuned circuits associated with the r.f. amplifier tubes functioning to complete the selection of the desired signal and at the same time to couple together the various stages of r.f. amplification. The output of the r.f. amplifier feeds into a grid leak-condenser detector. This type of circuit was used because of its greater sensitivity and because it was considered that for all around use it was entirely satisfactory.

The task of the constructor of a Hi-Q 30 receiver is simplified because the receiver is purchased in the form of several completely wired units which need only be connected together. For example, the pre-selector unit consists of three shielded compartments for the coils and another shielded compartment for the three variable condensers associated with the band-pass unit. The three-stage r.f. amplifier consists of three shielded compartments for the tuned r.f. transformers (the necessary r.f. choke coils and by-pass condensers that com-

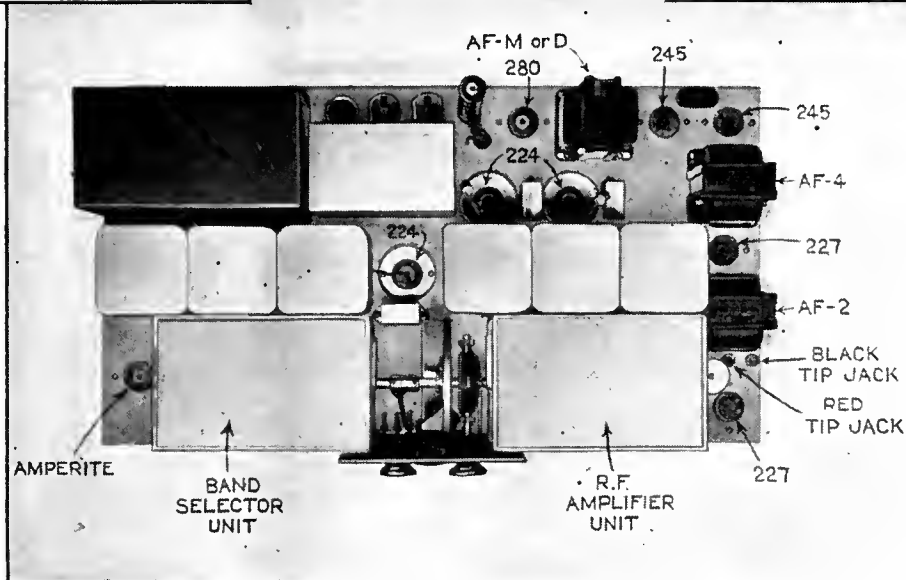

pose the filter circuits are also located in the shields) and another shielded compartment for the three variable condensers used to tune the three r.f. transformers. Leads are brought out of the shields for connection to the tubes and other parts of the circuit. Both of these units are completely wired and tested at the factory so that the constructor doesn't have the problem, generally of major importance in the construction of a receiver, of securing coils and condensers which will gang together accurately.

The kit includes a completely drilled metal sub-panel to which the band-pass unit and r.f. amplifier units can quickly be attached. In addition the sockets, a.f. transformers, and a few other small units

must be connected to the sub-panel. The fact that the two major units are completely assembled, of course, greatly simplifies the work of constructing the complete set. On the front panel of the completed receiver there are four controls, the main tuning dial which turns all of the variable condensers, the volume control, the on-off switch, and the phonograph - radio switch. Since, as indicated by the circuit, the phonograph switch connects the pick-up unit directly to the grid of the detector tube, it was not considered advisable to run a long lead from the detector grid to the center of the panel where the control is located. As a result, the switch actually controlling the connection to the phonograph pick-up is located on the sub-panel close to the detector socket and this switch is connected by a wire link to another switch on the front panel. The phonograph-radio switch on the front panel, therefore, makes the necessary change in the electrical circuits through the additional switch located near the detector socket.

In previous years kit receivers were usually sold either without a cabinet or complete with a metal cabinet and the constructor who desired to build a set into a console had to arrange to purchase the console separately. This season, however, Hammarlund-Roberts, Inc. has had designed several special cabinets and consoles, especially for use with the Hi-Q 30.

The receiver itself is available in various models for a.c. or d.c. operation, and either complete with a.f. amplifier or just the tuner circuit up to and including the detector.

Hammarlund-Roberts, Inc., has issued a complete 48-page manual (Continued on page 239)

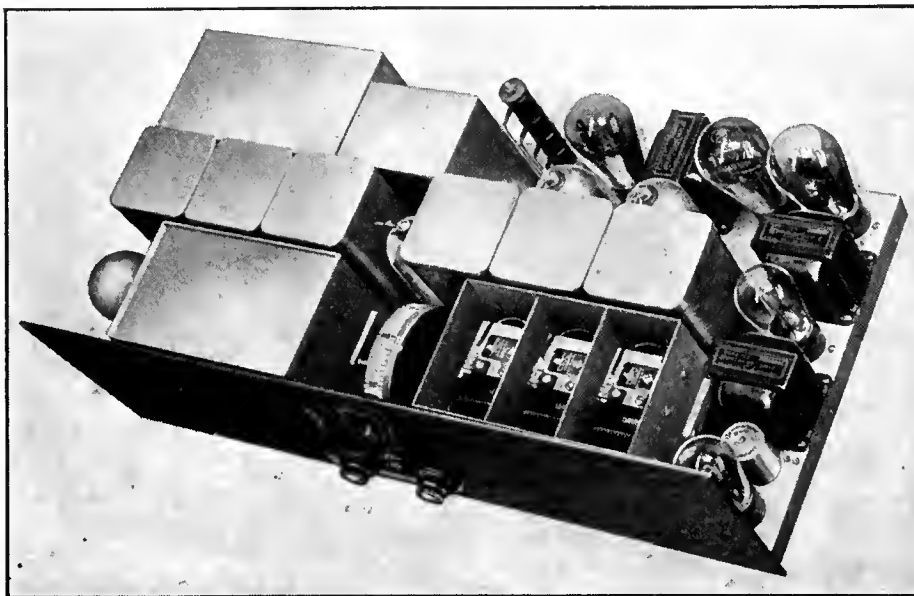

View of the Hi-Q 30 chassis.

BAND-PASS FILTER CIRCUITS

By E. A. UEHLING

COUPLED CIRCUITS are among the most common of the phenomena with which the engineer has to deal. Very often he will consider this phenomenon to be among the most useful as well, and one without which he would attain with great difficulty the results that are achieved easily with the aid of this principle. On the other hand, the phenomenon of coupling is so prevalent in nature that its complete isolation under certain experimental conditions is often a serious obstacle, with the result that errors in measurement of which the experimenter is not aware are often introduced. Coupled circuits are not confined to electrical work alone. They are probably even more common in mechanics, and perhaps in this field they are even more difficult to control.

Importance of Phenomenon

There can be no question about the importance of this phenomenon. This importance becomes especially apparent when we realize that the band-pass filter is but a specialized case of a general condition of coupling existing everywhere in nature where electrical oscillations or mechanical vibrations are to be found. Systems may be coupled to one another either electrically or mechanically, and under certain conditions the coupling between them will be felt in each of the circuits as an actual change in the impedance of the circuit, without, however, any evidence of the band-pass phenomenon. Very specialized conditions must be applied to the circuits to produce the latter results. These conditions and the exact nature of the effects produced form the subject matter of any discussion of band-pass filters.

In this article we consider such band-pass circuits as are suitable for use in radio broadcast receivers, remembering, however, that the subject has been artificially narrowed, and that the same methods can be and are readily applied to other fields of work, one of these being the subject of mechanical vibratory structures. The latter application as well as the former has been given a very thorough experimental treatment within recent years.

It seems hardly necessary to point out the advantage of a rectangular selectivity characteristic in a radio broadcast receiver. It is true that the width of the rectangle must fall within very narrow limits to be valuable, and its failure to do so in many cases is responsible for a certain amount of skepticism regarding the value of the band-pass circuit itself. This method of signal selection is only slightly more complicated than ordinary tuned circuits, and from the mechanical point of view is more complicated only in the requirement of an additional one or two condensers, depending on the number of sections of filter used and whether or not the band-pass filter is to constitute the entire signal selection unit of the receiver or whether it is to be combined with tuned circuits. At the same

time there may be certain simplifications in mechanical design introduced, especially if there are many sections of filtering used. The shielding requirements in the filter itself need be only such that the coupling between circuits should be as calculated and designed, and these requirements may not be nearly so rigorous as are the requirements of shielding in the stages of amplification. In such a receiver the amplification unit may consist only of r.f. tubes and untuned r.f. coils, making

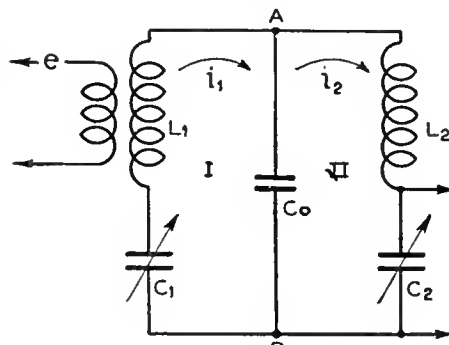

Fig. 1

possible a mechanical design that is very compact and economical.

Explanation of Operation

To be appreciated the band-pass filter must be understood physically. We should desire to know what it is that causes a system of circuits of this type to offer an extremely low impedance to currents of a given range of frequencies, and then to change its characteristics very sharply, offering for another and a very narrow range of frequencies a very high impedance, and then, at a certain frequency, to return to its former characteristics for all remaining frequencies and offer again a low impedance. A typical circuit having characteristics of this kind is shown in Fig. 1. L_1 and C_1 are resonant at a certain frequency, f . If L_2 and C_2 are equal to L_1 and C_1 respectively, the entire series cir-

cuit that includes these four reactance elements is resonant at the same frequency, f . Points A and B are then at the same potential and there can be no current flowing through the capacity C_0 . This zero current through C_0 can be replaced by two currents 180° out of phase with each other flowing through C_0 giving a resulting current in C_0 that is zero. Then what we have said regarding the equality of the potentials at point A and B is equivalent to saying that the current I_1 of circuit I is in the same phase as the current I_2 of circuit II at this frequency, f . For frequencies lower than f the reactance of L_1C_1 and L_2C_2 is negative and the capacity C_0 acts as a short circuit across both reactances so that there can be no current flowing in L_2C_2 . But as the frequency is increased above f the reactances of L_1C_1 and L_2C_2 become positive. If the frequency is only slightly higher than f , this positive reactance is low in value and a low value of potential is developed across C_0 . Current then flows in C_0 , the value of this current depending on the potential across C_0 , which in turn depends upon the positive reactance of L_1C_1 and L_2C_2 . Since this current through C_0 is the resultant of two currents, that in circuit I and that in circuit II, the relative phase of the currents in circuits I and II must have changed from zero to some other value less than 180° . As a consequence there is no change in the actual magnitude of the current in either circuit, and, therefore, the voltage across either L_2 or C_2 , which is the voltage to be amplified, is approximately equal to its value at frequency f . As the frequency is further increased the relative phase of currents I_1 and I_2 continues to increase with no change in the actual magnitude of either I_1 or I_2 , and consequently with no change in the voltage that is to be amplified, until the frequency has been raised sufficiently high above f that the currents I_1 and I_2 are 180° out of phase. Then, for any further increase in frequency, the positive reactance of L_1C_1 and L_2C_2 is so high that the potential developed across them and across C_0 can no longer be given as the product of the impedance of the condenser C_0 with the vectorial sum of I_1 and I_2 unless both I_1 and I_2 are reduced in value. This reduction in the value of I_1 and I_2 for further increases in frequency is a very rapid one.

This explanation of a band-pass filter can be shown even more graphically by the use of an application of the filter in mechanical structures. But, as we are concerned at this time principally with the band-pass filter as used for the purpose of selecting a given band of radio-frequency signals, an explanation of its operation in mechanical structures would not contribute a great deal to the present subject.

Electrical Characteristics

Several important conclusions become obvious when the principle of the hand-pass

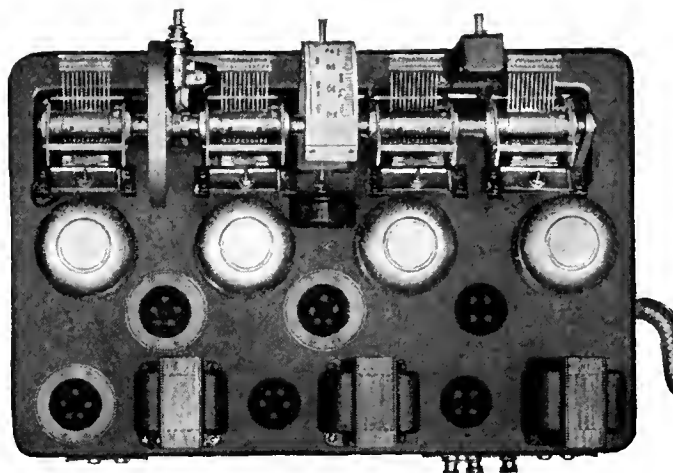

The Fada Model 35 chassis which uses a band-pass input circuit; the cable at the right connects with the power unit.

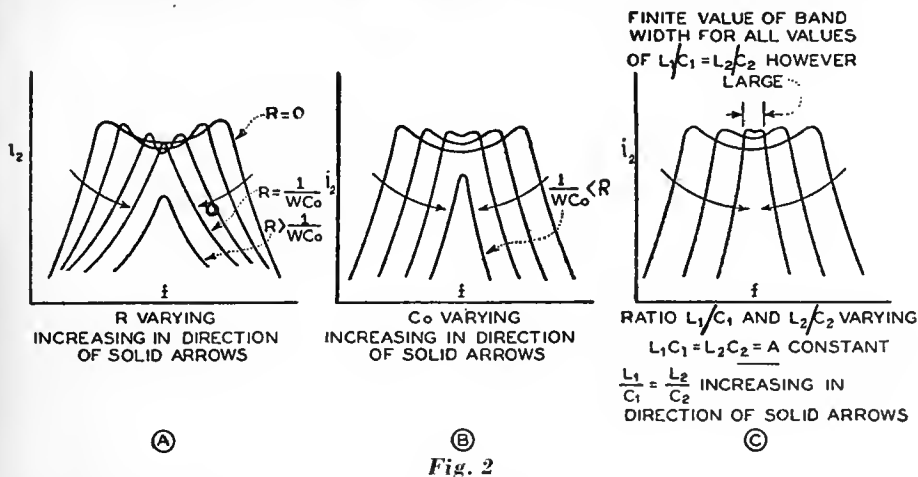

filter is understood. The first of these concerns the slope of the sides of the band-pass transmission characteristics, on which the selectivity advantage of the band-pass filter depends. The radio engineer is especially interested in the nature of the characteristic at the lowest and the highest frequencies of the band-pass transmission characteristic. It has been shown that for circuits coupled capacitatively the lowest frequency transmitted by the filter occurs when the reactances of each of the elements, L_1C_1 and L_2C_2 , is equal to zero. In practice L_1C_1 and L_2C_2 contain resistance and therefore the current through C_0 at this frequency is not quite zero, and I_1 and I_2 as a consequence do not have quite a zero phase relationship. At the upper frequency of transmission they do not for the same reason have quite a 180° phase relationship before there is a reduction in the value of I_1 and I_2 . We see that with increasing resistance we have not only a reduction in the width of the transmitted band, but we have also a more gradual approach to the maximum value of the currents as well as a reduction in the actual value of I_1 and I_2 throughout the band. The result is reduced selectivity and reduced transmission.

In Fig. 2 there is a graphical representation of the changing frequency characteristic with variation in the circuit constants of the filter. The voltage acting in circuit I is held constant, and I_2 is plotted as a function of frequency for each of several conditions of the circuits. It becomes obvious at once that the maximum value of I_2 depends only on the circuit resistances, that the slope of the sides of the characteristic at the lower and higher cut-off frequencies depends on the resistances, and that for a given value of C_0 the width of the transmitted band depends on the circuit resistances.

Though the entire discussion so far has been on the capacitatively coupled filter it is probably obvious that these statements hold, qualitatively at least, for filters with any type of coupling, the difference being usually one of sign, or degree, or both. Before entering into a discussion of the relative merits of the different types

of filters we shall need certain design equations which can be applied to any type of filter regardless of coupling and regardless of the number of sections, the discussion being confined, however, to successively coupled lines as distinguished from lines with lumped constants. In other words, the equations that will be given are directly applicable to typical circuits used in broadcast receivers.

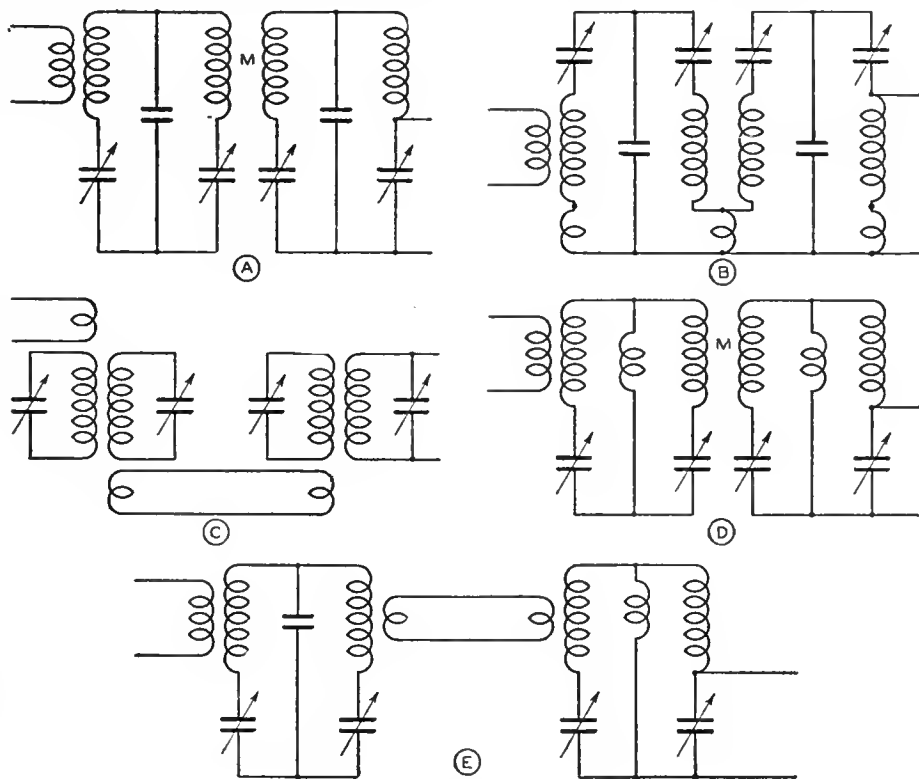

Design Equations

The design equations relating to band-pass filters are obtained directly from

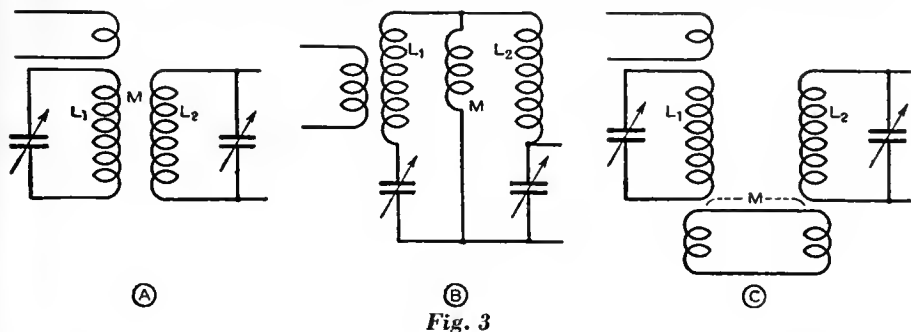

standard equations for a chain of circuits. These equations can be fitted to any specific case by omitting the unnecessary factors and substituting the proper values. Consider the circuit of Fig. 1. The maximum values of I_2 and I_1 , are given by the equations—

$$I_1 = \frac{E}{z_1 - \frac{m^2}{z_2}} = \frac{E}{z_1} \quad (1)$$

$$I_2 = \frac{mI_1}{z_2} = \frac{mE}{z_1 z_2} \quad (2)$$

where E is the equivalent voltage acting in circuit I due to the voltage e , m is the complex mutual impedance which may be capacitative, inductive, or a combination of both, and z_1 and z_2 are the total complex impedances of circuit I and II. Rationalizing z_1 we obtain a more convenient expression for the denominator of the equation which expresses the value of I_2 —

$$z_1' = z_1 - \frac{m^2}{z_2} \quad (3)$$

and if the coupling is inductive

$$z_1' = R_1 + \frac{\omega^2 M^2}{Z_2^2} R_2 + j(X_1 - \frac{\omega^2 M^2}{Z_2^2} X_2) \quad (4)$$

The current I_2 is a maximum when the

denominator $z_1' z_2$ is a minimum. To determine the minimum value of $z_1' z_2$ we must eliminate j and differentiate with respect to the reactances. Then—

$$Z_1^2 Z_2^2 = \omega^4 M^4 + 2\omega^2 M^2 (R_1 R_2 - X_1 X_2) + R_1^2 R_2^2 + X_2^2 R_1^2 + X_1^2 X_2^2 + R_2^2 X_1^2 \quad (5)$$

As used in a radio receiver R_1 is usually equal to R_2 and X_1 is equal to X_2 . Then—

$$Z_1^2 Z_2^2 = \omega^4 M^4 + 2\omega^2 M^2 (R^2 - X^2) + R^4 + X^4 + 2X^2 R^2 \quad (6)$$

$$\frac{\partial [Z_1^2 Z_2^2]}{\partial X} = 4X^3 + 4XR^2 - 4X\omega^2 M^2 \quad (7)$$

For a maximum value of I_2 this quantity

is equal to zero. Then the following formulas apply—

$$4X^3 + 4XR^2 - 4X\omega^2 M^2 = 0 \tag{8}$$

$$X^2 = \omega^2 M^2 - R^2 \tag{9}$$

$$X = \pm \sqrt{\omega^2 M^2 - R^2} \tag{10}$$

and if the coupling is capacitive

$$X = \pm \sqrt{\frac{1}{\omega^2 C^2} - R^2} \tag{11}$$

The upper and lower cut-off frequencies of the transmitted band occur when the reactances of the circuits take on the positive and negative values given by these equations. Then the frequency width of the band is given by—

$$f = \frac{\sqrt{\omega^2 M^2 - R^2}}{2\pi L} \text{ for inductive coupling} \tag{12}$$

$$f = \frac{\sqrt{\frac{1}{\omega^2 C^2} - R^2}}{2\pi L} \text{ for capacitive coupling} \tag{13}$$

$$f = \frac{\sqrt{B^2 - R^2}}{2\pi L} \text{ for any type of coupling where B is the absolute value of the coupling impedance} \tag{14}$$

The value of I_2 at the upper and lower frequencies is—

$$I_2 = \frac{E}{2R} \tag{15}$$

These equations, together with the design data relating to ordinary radio-frequency circuits, are sufficient for the design of any two-section band-pass filter. The performance of the filter at various values of ω is expressed implicitly, and some consideration of these equations is necessary for a complete understanding of the most suitable type of filter for a given purpose. The principal requirement in a radio receiver is that for variations in ω over the broadcast range there should be as little variation in the width of the transmitted band as possible. An approximation to this ideal can be obtained in several ways, each of which will be discussed with a little detail.

We have to deal first of all with the inductively coupled filter. The mutual impedance is obtained by coupling two circuits together very loosely by any one of three or more different methods as shown in Fig. 3. In this type of filter the mutual impedance varies considerably with frequency, and as a consequence the frequency width of the transmitted band varies with frequency. There are, however, conditions under which this variation in band width can be considerably reduced. Well-known methods in the design of the r.f. coils can be used to obtain coils that have a considerable variation in resistance with variation in frequency. Such coils will have a rather high resistance at low frequencies as well, and the transmission characteristic of the filter will not, in general, be very good at any frequency. But if a number of sections of band-pass filter are used, and if the function of signal selection is performed by this filter alone without the aid of ordinary tuned resonant circuits the overall characteristic may be very good with respect to both selectivity and constancy of width of the band-pass characteristic.

Similar results can be obtained using a single-section, capacity-coupled, band-pass filter in conjunction with several stages of tuned-radio-frequency amplification. The width of the transmitted band of a capacity-coupled filter decreases with increasing frequency. The selectivity of ordinary tuned circuits, on the other hand, decreases with increasing frequency. As a result, the combination of these circuits may have a very good frequency characteristic, and the selectivity may not vary appreciably over the broadcast range.

A third type of two-section, band-pass

filter has a coupling between sections that is a combination of capacitive and inductive elements. It has a very useful application for certain kinds of work but is not suitable for multi-frequency purposes as in a radio receiver. This is true because the variation of reactance with frequency of any combination of inductances and capacities is greater than that of either inductive or capacitive coupling. Of the two latter types of coupling the arithmetic variation of reactance with frequency of the capacitive type of coupling is less than that of inductive coupling. (See RADIO BROADCAST, page 171, July, 1929.)

Another Type

We will now leave the two-section filter and consider several types of circuits that are capable of performing the entire function of signal selection. Such a circuit would constitute one unit of a receiver, distinct in every particular from the amplification unit which would follow it. The most obvious method, and the one we will consider first, of attaining this result is to couple together several such filters as already discussed by means of a coupling unit in which the value of coupling is deficient. Several such circuits are shown in Fig. 4. If the coupling between alternate sections is deficient, the overall characteristic will be similar to that of a two-section filter of the same type as the component members and superior to the characteristic of one such member in the same way that two or more resonant circuits are superior to one. Four resonant circuits grouped together in this way will provide a filtering system that will meet the selectivity requirements of all but the most exacting conditions. The characteristic of such a filter will consist of two frequencies of maximum transmission with a frequency region of slightly reduced transmission between them, and external to this region and sharply divided from it are two regions of practically zero transmission. Uniformity or lack of uniformity in performance over the broadcast range will depend upon the same factors as those which influence the separate units as already discussed under the heading of two-section filters.

A very interesting type of structure is shown in Fig. 4E. Filter circuits of different characteristics are coupled to each other deficiently. In this filter the capacitatively coupled section would probably be adjusted to have the same width of transmitted band at 200 meters that the inductively coupled section has at 545 meters. The characteristic of the entire circuit at one end of the broadcast range would then be almost identical with its characteristic at the other end. The selectivity of this circuit is not exceptionally good but there is a close approximation to uniformity over the entire broadcast range. Such circuits present many interesting possibilities, and many such combinations have been found to be more successful in practice than would be anticipated from theoretical considerations alone. Results closely approaching a good band-pass transmission characteristic that is maintained over the entire broadcast band have been obtained with circuit arrangements similar to those shown in Fig. 4.

Conclusions

It is not absolutely essential that the coupling between groups of circuits be deficient. If this coupling is not deficient, however, the band-pass characteristic will be altered in a manner difficult to estimate or to express in equations. Under circumstances of sufficient coupling between all circuits more than two frequencies of maximum transmission will exist. The

characteristic may, however, be well suited to radio broadcast reception purposes, the principal consideration when more than two peaks exist being that the maximum width of the transmitted band be less than the 10,000 cycle limit generally accepted as the frequency width of the channel. If, on the other hand, the coupling between any two of the entire group of circuits is far below that of sufficient coupling the transmission loss will be high and the amplification required following the signal selector will be greater than otherwise necessary.

Circuits that give more than two frequencies of maximum transmission give results superior to those obtained with circuits similar to the ones already discussed in that the curve is more nearly flat between the lowest and the highest transmitted frequency. Characteristics of this nature are obtained if three or more consecutive tuned circuits are coupled to one another with approximately equal values of coupling. Such circuits have not become very important in receiver design, but for the sake of completeness they should be mentioned. The design characteristics might be determined in the same manner as used in determining the design equations for two-section filters, using corresponding equations for the currents in the individual circuits, as for example—

$$I_1 = \frac{E}{z - \frac{m^2}{z - \frac{m^2}{z - \dots}}} \tag{16}$$

where there are as many (z)'s appearing in the chain of the denominator as there are circuits in the chain of the filter. These equations for a three-section filter are—

$$I_1 = \frac{E}{z - \frac{m^2}{z - \frac{m^2}{z}}} = \frac{E}{z''} \tag{17}$$

$$I_2 = \frac{m I_1}{z - \frac{m^2}{z}} = \frac{m I_1}{z'} = \frac{m E}{z' z''} \tag{18}$$

$$I_3 = \frac{m I_2}{z} = \frac{m^2 E}{z z' z''} \tag{19}$$

when the individual circuits are identical and equal coupling is used between circuits.

Rationalizing the expressions for z' and z'' we have—

$$z = R + jX \tag{20}$$

$$z' = R + \frac{\omega^2 M^2}{Z^2} R + j(X - \frac{\omega^2 M^2}{Z^2} X) \tag{21}$$

$$= R' + jX' \tag{22}$$

$$z'' = R + \frac{\omega^2 M^2}{Z'^2} R' + j(X - \frac{\omega^2 M^2}{Z'^2} X') \tag{23}$$

$$= R'' + jX'' \tag{24}$$

Of the various hand-pass filters considered, the double two-section type has been found most satisfactory. If designed according to the principles discussed above, filters of this type can be made to provide all the signal selection required in a radio receiver, and these properties can be made practically uniform over the entire broadcast range. Uniform signal selection is a property that is very imperfectly realized at best, and tuned circuits are subject to the same criticism in this regard as band-pass filters. Band-pass filters have the great advantage that they are subject to manipulation, as has been shown, and compromise characteristics can be obtained under certain conditions without any sacrifice in actual selectivity, and without a very large loss in transmission properties.

TUBES AS AMPLIFIERS

TUBES in modern radio receivers serve three functions, they amplify, they detect, and they rectify. Although many sets have six or seven tubes only one of them detects and one, or at most two, rectify. All the rest amplify. The question that interests the person who wants to know more about tubes is, how does the tube amplify, and how much?

To understand how the process goes on, consider Fig. 1 which represents the plate current in milliamperes at any value of grid voltage. Thus, at 3.0 volts on the grid, the plate current is 3.0 milliamperes. If this voltage changes, the current changes. If the voltage is made to change at some regular rate, at 60 cycles, for example, the plate current will go up and down from some average value in unison with this changing grid voltage. This changing plate current must flow through the internal resistance of the tube and with any external resistance (called the load) connected in the plate circuit. This changing current in flowing through these resistances causes a voltage drop to appear along the resistances.

For example, a change of one volt, plus and minus from the average value of the grid bias, may cause a change of one milliamper plus and minus in plate current. If the internal (plate) resistance of the tube is 12,000 ohms, one milliamper flowing through it causes a potential drop of 12 volts. But note that only one volt on the input of the tube results in 12 volts appearing in the plate circuit. The tube has amplified a voltage.

In the above case there is a total of 12 volts available. If a load resistance is in series with the tube, the changing plate current must flow through it too, and thus a voltage will appear across this external load resistance. This voltage may be utilized. That lost within the tube itself cannot be usefully employed. But 12 volts is the total available. How much can be made to appear across the load?

If two equal resistors are in series and 12 volts appear across them, 6 volts will be across one resistor and 6 across the other. If, however, one resistor is much greater than the

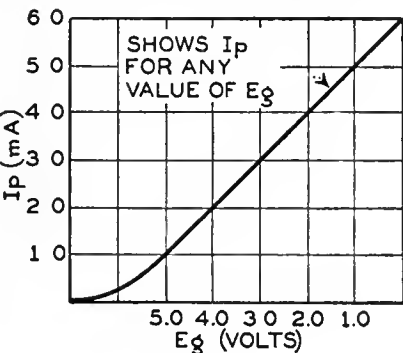

Fig. 1

other, say 5 times as great, a much greater proportion of the total voltage will appear across it. Its share will be correspondingly greater. If, then, a 12,000-ohm tube (201-A) has in series with its plate circuit a 36,000-ohm resistor and 12 volts are available, 9 volts will appear across the resistor and 3 volts will be lost in the tube.

The actual relation between useful voltage and the two resistances is shown in equation (1) in which R_p is the tube resistance and R_o is the output resistance.

$$\text{Useful voltage} = \text{Total voltage} \times \frac{R_o}{R_o + R_p} \quad (1)$$

Now the fact that more voltage (a.c.) appears in the output of the tube than is put into its input is expressed in one of the so-called defining constants of the tube, the amplification factor or mu (μ). Thus if the mu of the tube is 3, there will be a total a.c. plate voltage of 3 when 1.0 volt (a.c.) is put on its grid. The voltage amplification, G, that results from using a tube and load resistance is given by

$$G = \mu \times \frac{R_o}{R_o + R_p} \quad (2)$$

and the total available a.c. voltage is equal to μE_g because an input voltage E_g is multiplied by μ and reappears in the plate circuit as μE_g .

If the second part of Equation (2), $\frac{R_o}{R_o + R_p}$ is very large (i.e. approaches unity) the value of G will be very nearly equal to the mu of the tube.

When there is a voltage of μE_g in the plate circuit the current (a.c.) that will flow is equal to—

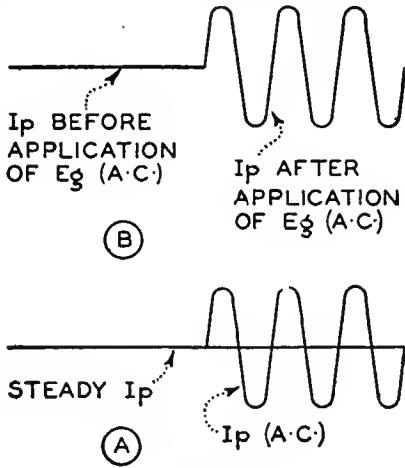

Fig. 3

$$\text{plate current (a.c.)} = \mu E_g / R_p \quad (3)$$

or it is equal to $E_g \times G_m$ in which G_m is the symbol for mutual conductance, another of the factors which describes a tube to an engineer.

Thus if one volt (a.c.) is put on the grid of a tube whose mu is 3 and whose plate resistance is 3000 ohms, an a.c. plate current of one milliamper will flow. Thus $I_p = (E_g \times \mu) / R_p$ or $(1 \times 3) / 3000 = 0.003$ amperes or 3 milliamperes. This does not mean that if there is some external load resistance there will be 3 milliamperes flowing for such is not the case. The current will fall off according to Ohm's law and the mutual conductance of the circuit decreases as the load resistance increases. If, in the above case, an 8000-ohm load is in series with the tube, the plate current (a.c.) will be only 4 milliamperes because the total resistance, through which μE_g must force current, has been doubled. Thus an input of 1 volt (a.c.) will cause an a.c. current of only 4 mA, and the G_m of the entire circuit will be half that of the tube alone.

We now know all the major factors of the tube and their relation to the input and output voltages, and the a.c. plate current. They may be summarized as in Table I.

A. C. plate current

The fact that there may be an a.c. current in the plate circuit as well as a current which affects a d.c. meter mystifies many readers of radio articles. Is it possible for a d.c. current and an a.c. current to flow through the same circuit? Yes it is. Look at Fig. 2 which is the familiar output coupling system of a power tube. A. C. currents are prevented from going through the choke L by its high impedance to these currents; d.c. currents are prevented from going through the loud speaker by the condenser C; but both currents must flow through the tube.

There are two ways of looking at this alternating plate current business. One is to say that when an a.c. grid voltage is put on the tube, an a.c. plate current flows in addition to the direct current (Fig. 3A). Another way is to state that when an a.c. grid voltage is applied, it adds to or subtracts from the steady or d.c. voltage already there due to the C bias. When this steady bias is decreased because the a.c. voltage is positive, the plate current increases; when the steady bias is increased because the a.c. input is negative and adds to the C bias, the plate current decreases. Thus the no-signal value of the plate current goes up and down in unison with the changes occurring in the grid voltage (Fig. 3B). A plate current meter is too sluggish in its motions to follow these variations, and so indicates the average value.

So long as the plate current increases and

Table I

Total a.c. plate voltage	μE_g
Useful a.c. plate voltage	$\mu E_g \times R_o / (R_o + R_p)$
Voltage (a.c.) lost on tube	$\mu E_g \times R_p / (R_o + R_p)$
Voltage amplification in tube circuit	$\mu \times R_o / (R_o + R_p)$
Alternating plate current	$\mu E_g / (R_o + R_p) = E_g \times G_m$
Mutual conductance $G_m (R_o = R)$	$\frac{\text{a. c. plate current}}{\text{a. c. grid voltage}}$
Mutual conductance ($R_o = 0$)	μ / R_p

Note. Answers to these problems will be found on page 239.

decreases equal amounts from the steady no-signal value, there will be no change in the value of current indicated by the d.c. meter. If, however, the current on the positive half cycle increases more than it decreases when the grid is less positive, the average current will change and the plate current meter will show an increase in plate current. Such a change is an indication that the plate current (a.c.) is not an exact replica of the a.c. input voltage. In other words, distortion is taking place.

Screen-Grid Tube

Suppose a tube has such a high plate resistance that whatever you put in series with it makes little difference to the plate current (a.c.). For example, a 227 with 10,000 ohms would have almost the same alternating plate current if 1000 ohms were added to the plate circuit. But if you were to add another 10,000 ohms, or even more, the alternating plate current would decrease. In other words, the mutual conductance of the circuit, i.e., the relation between alternating current output and input alternating voltage, decreases.

The plate resistance of the screen-grid tube (2Y24) is about 400,000 ohms. Its mutual conductance is about one 1000 micromhos. Now if you put 50,000 ohms in series with the tube the a.c. plate current will only decrease by about ten per cent, and the mutual conductance will decrease the same extent.

We can say, then, that with a high-resistance tube, the mutual conductance of the circuit is about the same as for the tube with no-load resistance, that the alternating plate current in the entire circuit is equal to the alternating grid voltage multiplied by the mutual conductance, and that the voltage amplification from such a tube is equal to the product of the mutual conductance and the load resistance. Thus—

$$\begin{aligned} \text{A.C. current (with or without load)} &= E_g \times G_m \\ \text{Voltage amplification} &= G_m \times R_o \end{aligned}$$

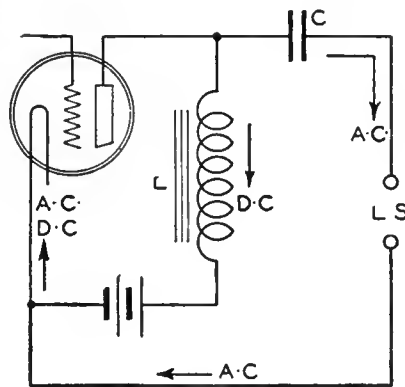

Fig. 2

It is interesting to note that the maximum amplification that can be secured from a screen-grid tube working into a resistance is the mu of the tube, but that the maximum amplification attainable from a screen-grid tube depends not so much upon its amplification factor but upon the mutual conductance. This is because the load resistance that can be built up for the tube to work into is limited—we cannot get resistances beyond perhaps 200,000 ohms in an r.f. circuit at broadcast frequencies, or much less than this figure at higher frequencies.

Problems

1. A 227-type tube ($R_p = 10,000$ ohms, $\mu = 9$) is worked into a load of 30,000 ohms. What is the voltage amplification?
2. It is desired to use 90 per cent. of the possible amplification from a 240-type tube. Its $\mu = 30$, $R_p = 150,000$ ohms. What load resistance is required?
3. The plate resistance of a tube is 2000 ohms; its amplification factor is 3. If 10 volts were put on its grid what would be the a.c. plate current? What would be the a.c. current through a load of 4000 ohms?
4. A 250-type tube with 450 volts on the plate requires a C bias of 84 volts. If a peak input voltage of 75 could be put on the tube, what would be the actual grid voltage range? The amplification factor of the tube is 3.8; its μp is 1800 ohms. If it were worked in to 3600 ohms, what would be the a.c. current through the load and the a.c. voltage across it under the above conditions?

SIMPLE L x C MEASUREMENTS

"HOME STUDY SHEET" No. 20 in April, 1929, RADIO BROADCAST gave directions for winding an inductance which could be used as a standard in the serviceman's or the experimenter's laboratory. In "Home Study Sheet" No. 21 (May issue) is a description of a bridge for use in comparing unknown inductances to this laboratory standard, or in measuring unknown capacities in terms of a standard made according to "Home Study Sheet" No. 24; the following Sheet, No. 25, described a buzzer which may be used to good advantage in the laboratory.

It is a simple matter to measure unknown inductances or capacities if a standard and a grid-dip meter oscillator is available, but frequently such an oscillator is not handy. If the laboratory has a high-pitched buzzer and the above mentioned standards, an unknown capacity or inductance can be measured by a very simple experiment. In addition to the above apparatus, it requires only a crystal detector and a pair of headphones. As a matter of fact the method described in the following paragraphs is often of greater convenience than the bridge since it takes up less room, requires less apparatus, and measures the coil under operating conditions.

The Crystal Detector

There is probably nothing about the laboratory that can be more annoying or more satis-

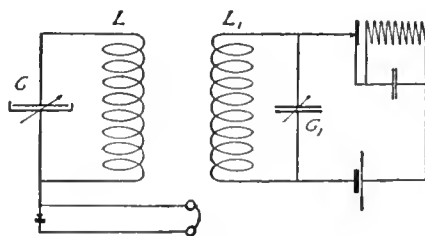

Fig. 3

factory than a crystal detector. When the latter condition is the case, it provides, in connection with a telephone receiver, a means of detecting radio currents that are almost infinitesimal. Almost invariably when trouble is experienced in using a contact detector, it is due to the use of inferior crystals. If about an ounce of fairly fine grained steel galena of good quality can be procured, no further trouble will be encountered. Many crystals, more often the smooth surfaced cubes are practically worthless, but with galena of the proper sort, it is more difficult to find an insensitive point than one that is sensitive. In this so-called steel galena the rough surface is simply due to the thousands of minute crystals that form its structure, and when it is used, the cat whisker is not displaced easily.

As the crystal detector in laboratory work is frequently connected to the circuit with only one wire, it is very convenient to provide a small inclosed detector that may be snapped onto the binding post of a condenser or some other piece of apparatus. Fig. 1 will prove suggestive. The shell is a piece of tubing cut from a small fountain pen or rubber pen-holder. On one end a heavy brass cap is forced on, and is threaded for a set screw to hold the crystal. Soldered to this cap is a spring clip, which holds the detector in place and makes the one-way connection. On the other end is another cap, held by friction, but not so tightly that it cannot be removed with the fingers. Through the center of this runs a small brass rod, tipped with a springy cat whisker of fine bronze wire, about number 30. The rod is surrounded by a compression spring, which, with the flange outside the brass cap, operates to hold the rod in position, but by pulling on the rod and turning it a little, a new spot on the crystal may be found quickly. This fact is not very apparent from the illustration, but it is so in actual use, as the cat whisker is never exactly central, and numerous points are accordingly found. To hold the tips of the receiver cord, spring clips should be provided and soldered to the two brass caps.

Such a detector, being small and condensed, adds but little capacity to disturb the circuit. It is dust proof, and, with good galena, it may be removed and replaced repeatedly without losing the sensitive point. Inclosed detectors may now be purchased, but usually they are so large as to be inconvenient.

Sometimes it is desirable to avoid an outside connection with a circuit involved in some

quantitative determination, and, in such a case, the detector must be provided with a little pick-up coil of its own, so that the necessary current may be secured through induction. Fig. 2 shows a convenient way of arranging this. A small spiderweb or diamond-weave coil is attached to a base block in any convenient manner that will permit of its being replaced by another coil if desired. This will be necessary only in dealing with very short waves, when the natural wavelength of an ordinary coil might be identical or very close,

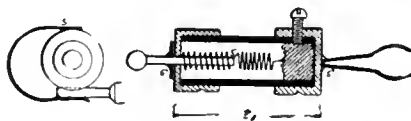

Fig. 1

and thus draw so much current as to disturb seriously the circuit under consideration. In any event it is not advisable to use more turns than are necessary—sometimes three or four are sufficient.

The crystal is snugly packed with tinfoil into the bottom of a brass tube or cartridge shell that has been well polished inside and out. This is held in position by inserting it into a suitable hole drilled into the base block about a quarter of an inch, and connection is made to it by bending into the hole the end of the spring clip which holds the tip of the receiver cord. The cat whisker is in the form of a spring, and comes up through a smaller hole in the base block. To obtain a new contact point on the crystal, it is only necessary to withdraw the cartridge shell partly, turn it a little, and push it down again. Such a detector is dust proof, and will give practically no trouble when good steel galena is used.

The tips of the receiver cord are held by slipping them under two strips of spring brass or bronze. The one referred to above makes connection with the crystal holder, and the other is placed crosswise on the base block and is connected directly to the coil, the other terminal of which goes to the cat whisker. By cutting a half-round groove in the base block under each spring clip, the cord tips will be held securely in position.

In using such a detector, a single receiver is sufficient and much more convenient than a pair with a head-band. The combination constitutes a sort of electrical divining rod, responsive to all wavelengths.

Measuring L or C

As shown in Fig. 3, a high-pitched buzzer and one or two dry-cell batteries are used to generate radio currents in the oscillatory circuit LC. It is not necessary that the values of this inductance and capacity be known, and if an extra variable condenser is not available, C₁ may be a fixed condenser. L is the inductance standard, and C is a calibrated variable condenser to the shielded side of which is connected a crystal detector and telephone receiver.

If the buzzer is now started, and the capacity

of C is varied, a point on the dial will be found where the buzzer note is clearly at a maximum. As the coils are separated, this point will become sharper. Therefore, the coils should be separated as far as will permit of a definite determination—say to a distance equal to about twice the diameter of the coils being used.

Having noted the point on the dial where resonance occurs, replace the known inductance with the unknown coil and retune, carefully noting the second point. Then the inductance of the unknown coil will be found from $L_x =$

$L_s \times \frac{C_x}{C_s}$. That is, to obtain the unknown inductance, multiply the inductance of the standard, L_s, by the capacity at which it was found resonant, C_s, and divide by the corresponding capacity, C_x, for the unknown coil. If this seems a little complicated, just remember that the same wavelength was used in both cases, in consequence of which L x C is the same in both cases. Therefore, if one coil requires half as much capacity as the other, its inductance must be twice as great.

In making such a determination, it is desirable that the inductance and capacity used in the generating circuit (L₁ C₁) be chosen so as to yield fairly high readings on the calibrated condenser, as the errors in reading small values are proportionately larger.

Simple though the foregoing procedure may seem, it is very significant, and illustrates the fundamental fact that for any given wavelength

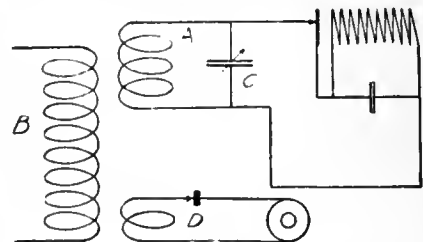

Fig. 4

there is only one value for the product of the inductance and capacity that will result in a maximum current.

If the laboratory worker has calculated, as he eventually should, the inductance of more than one coil, and has used the bridge to transfer his capacity values to another condenser, he may then use known values in the generating circuit. As a result he will have an additional check on his work.

Sometimes it is convenient to provide a coil with a fixed condenser, and then carefully determine the value of L x C and the corresponding wavelength, so that when they are used in a generating circuit, it will only be necessary to divide by the value of the calibrated condenser, at the point at which resonance occurs, in order to obtain the inductance of an unknown coil. Thus, if a coil has an inductance of 200 microhenries and the fixed condenser a capacity of 0.0005 microfarads, L x C would be 0.1 and the corresponding wavelength a little under 600 meters. Such a combination would not only serve the above purpose, but would immediately show whether a given coil and condenser would cover the upper limit of the broadcasting range.

The foregoing is all strictly true if the capacities C and C₁ are the total capacities across each coil, but we have purposely omitted to state that these capacities are not entirely within the respective condensers, but are, to a slight extent, found in the coils themselves, and are termed distributed capacity. If, however, the fixed or tunable capacities across the coils are fairly large (100 mmfd.) we can neglect the distributed capacity except in experiments where great accuracy is required.

The distributed capacity of a coil arises from the fact that each turn is composed of a metallic conductor separated from its neighboring turns by a non-conductor. This forms the essential elements of a condenser. All of these elemental capacities are in series so that a long lean coil has a lower distributed capacity than a short fat one.

Coils for use in the broadcast frequency band have capacities of less than 10 micro-microfarads.

It has been found by experiment that coils whose length is twice the diameter have a distributed capacity of 0.64 R where R is the radius of the coil in centimeters. If the length is half of the diameter the distributed capacity will be about 0.6 R.

Other experiments indicate that the distributed capacity of good coils is always less than the radius of the coil in centimeters.

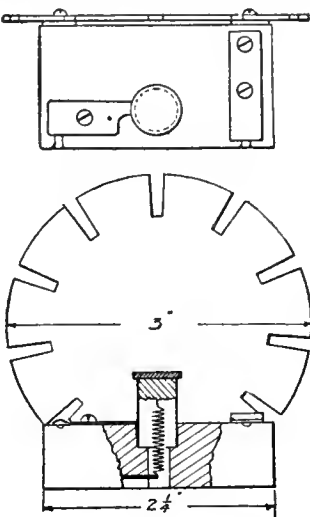

Fig. 2

An Instrument for Diagnosing Trouble in Radio Sets

THE SUPREME DIAGNOMETER

By FLOYD FAUSETT

Supreme Instrument Company

THE QUALITATIVE performance of a radio may be appreciated by the ear, but there are times when a radio suffers from certain ailments which the ear can diagnose only by stating that the radio sounds terrible, or does not sound at all. In such instances diagnosis of the difficulty must depend upon meters which can be read by the eye. The Supreme Diagonometer ("diagnosis by meter") has been designed for this purpose. It is a consolidation into a single unit of many different instruments each performing a distinct and useful function.

In addition to plate voltage and current readings which are obtainable with any set-tester, the Supreme instrument is equipped with an oscillator, a thermocouple meter, and other equipment so that the widest possible range of measurement is possible. There are more than forty different circuits in the Diagonometer with ready access to them all. The optional Weston or Jewell meter equipment of the Diagonometer consists of three instruments:

(1) a d.c. voltmeter of the "1000-ohms-per-volt" type, having 750/250/100/10/0 voltage scales and an a.c. thermocouple range of 250 milliamperes; (2) a d.c. ammeter-milliammeter of 2½/0 ampere and 125/25/0 milliamperes scales; and (3) an a.c. voltmeter of 750/150/16/4/0 scales. Nine scales of these meters are brought into the desired circuits by a special plunger selector "wiping-contact" switching system, and all of the eleven scales are available at external pin jacks for test uses.

The Diagonometer performs the functions of five separate units; namely, (1) tube-socket analyzer, (2) tube-tester,

(3) modulated oscillator, and (4) continuity indicator. All of these four essential measurements are performed without the necessity of batteries by utilizing a built-in transformer designed for operation with a 110-volt a.c. supply through a protective

of making comparative tests of tubes, and is preferable to testing tubes with power supplied by an operative radio. In fact, the serviceman quite frequently finds that a radio is inoperative so that no radio power is available for tube testing. Not

being able to ascertain the conditions of the tube equipment in such a case, the customer cannot be given a fair estimate of the total cost of putting the radio equipment in a satisfactory operating condition. Even where operative radios are available, the tube socket potentials differ between different sockets, and are affected by the differences of load conditions imposed by the transposition of tubes of more or less non-uniform characteristics among the different sockets of the receiver, one tube with poor characteristics being sufficient to make a material difference in the load carried by all other tubes. While the power plant feature is unquestionably advantageous, the Diagonometer oscillator circuits may be supplied with the conventional

battery power for tube testing where desirable, as in the rare situations where a 110-volt, 60-cycle a.c. supply is not available.

The tube socket analyzer utilizes a plug which affords analysis from the sockets of all radios, including screen-grid and "top-heater" types, all connections being brought into the Diagonometer through a single 6-wire cable, the design affording screen-grid analysis without causing these tubes to oscillate while the tubes and circuits are under test. Screen-grid, control-grid, positive and negative cathode, a.c. or d.c. filament, and plate potentials may be read by manipulation of corresponding switches while the plate current is simul-

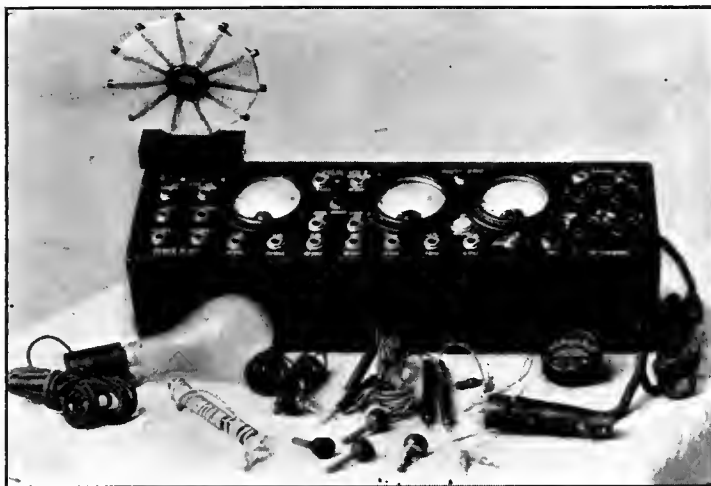

The Diagonometer and its accessories.

lamp and radio-frequency by-pass filter, and delivering secondary potentials of 1.5, 2.5, 3.3., 5.0, 7.0, 7.5, 10.3, and 15.0 volts. The protective lamp affords protection to the meters and circuits and offers visual indication of tubes having shorted elements. The a.c. line voltage may be observed during tests utilizing the power plant where the a.c. voltmeter is not otherwise employed.

The Power Plant

The power plant embodied in the Diagonometer provides circuits of definite characteristics, affording a reliable means

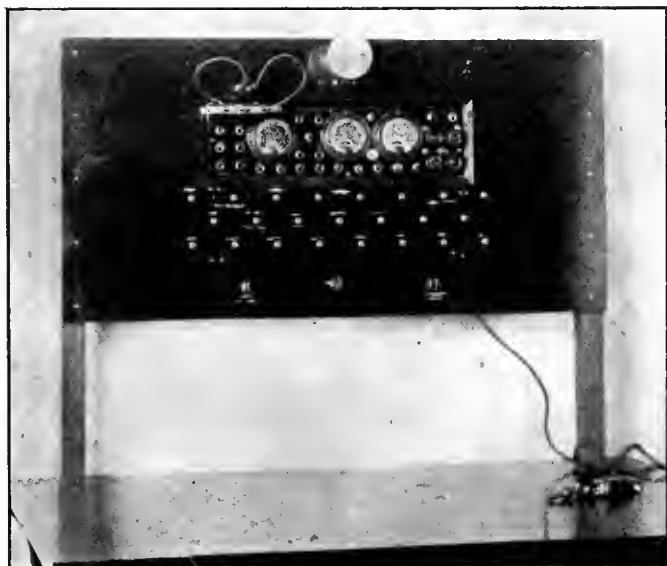

For use in the shop the Diagonometer may be mounted on a test panel.



In general service work the Diagonometer is carried in a compact leather case of the type shown above. The case also provides space for accessories and tubes.

taneously indicated on the milliammeter. The single analyzer adapter required for UY sockets is provided with a snap catch to prevent the separation of the adapter from the plug in radio sockets.

The Diagnometer analyzer arrangement is useful in the preliminary analysis of radio faults, its usefulness extending to power-pack analysis through the rectifier tube socket for isolating power-supply troubles where plate voltages are not delivered to the radio tube sockets. Where a rectifier tube is good, shorted filter condensers or shorted voltage dividers are indicated by full or excessive rectifier plate current readings, while open filter chokes and open plate-supply secondary circuits are indicated by low or no rectifier plate current readings. The 750-volt a.c. voltmeter scale is very useful for locating open and shorted rectifier plate transformer secondary windings.

The Circuit

The schematic diagram of the Diagnometer's modulated radiator and self-rectifying tube-testing circuits shown in Fig. 1 shows the simplicity of its various functions. The closely-coupled plug-in radiator coil is shown separated from the power circuit. The grid circuit is tuned with a fixed 0.0005-mfd. condenser and may be shunted by depressing the "stop-oscillation" switch shown. A biasing toggle switch is shown for shifting the grid return from either side of the power transformer secondary to the other side for changing the grid potential as a mutual conductance test for tubes. A by-pass condenser is connected across the line supply to keep the radio-frequency currents from the a.c. line. Fixed tuning of the oscillator circuits, with close coupling to afford several harmonics over the broadcast band, is utilized to maintain constant circuit values for matching and classification of tubes with the oscillation test.

The mutual conductance test with the Diagnometer is accomplished by keeping the "stop-oscillation" button depressed while changing the grid potential of the tube under test by means of the "zero-bias" switch, and observing the amount of change in plate current as read on the milliammeter. A tube which is within 25 percent of the average mutual conductance index for the type of tube under test is a good tube and should not be discarded.

In an effort to determine the effect of tube variations upon receiver performance the following test was made. A large quantity of new 226-type tubes were tested under identical conditions with "bias" oscillation plate current readings varying between 12 and 30, and averaging 18 milliamperes. These tubes showed little difference in mutual conductance and seemed to be equally sensitive by audible tests in a.f. amplifiers, and were all classified as good tubes. However, as each tube attained its maximum reading under the oscillation test, the signal produced by the oscillating tube was tuned to maximum audibility on an accurately calibrated receiver, and the fundamental radio frequency was determined. A variation of 60 kilocycles was noted between the extremes mentioned, the signals from the tubes showing identical oscillation test readings tuning at practically the same reading on the radio receiver. A receiver of the "band-pass" type was then equipped with tubes picked at random, and its sensitivity compared to the sensitivity of the same set

equipped with tubes of matched oscillation test readings, the sensitivity being observed by ear and also by utilizing the meter output measurements with the thermocouple method and with the a.c. voltmeter method. During the sensitivity observations, the same tube was used as the oscillator in the Diagnometer. The sensitivity of the radio was greater when matched tubes were used, irrespective of whether or not the tubes used were matched from tubes chosen at test ratings above or below the average.

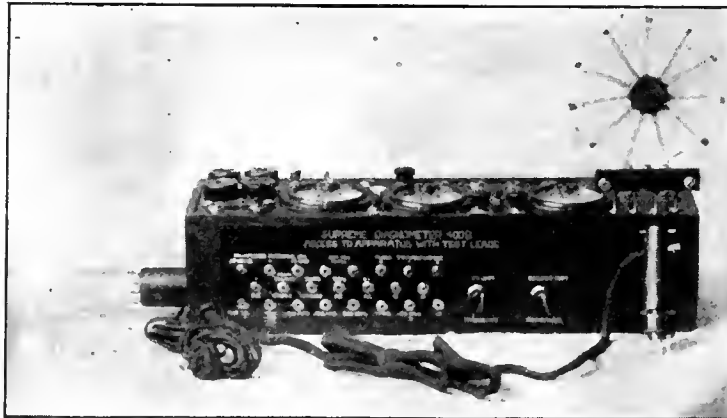

Rear view of Diagnometer showing external pen jacks.

Matching Tubes

These studies in tube variations led the writer to the conclusion that the careful matching and allocation of tubes is advantageous where it is desired to insure maximum radio performance, and this procedure has been followed in practice to the extent of using tubes of identical oscillation test ratings in the tuned stages of a receiver and utilizing the tubes of more radical oscillation ratings having good non-oscillation plate current ratings in a.f. stages. However, matched tubes are used in push-pull stages so as to eliminate or minimize hum and distortion, and full-wave rectifier tubes are chosen which have identical plate current readings for the two plates. Comparison of the plate current readings of both plates of full-wave rectifier tubes is interesting and often important in hum minimizing.

These service observations have been conducted in a territory in which practically every radio is sold by demonstration

in competition with other receivers in the prospective customer's home. Under these conditions it is very important that a radio be operating at its maximum efficiency before being installed. In practice, a radio is "tuned up" with well-chosen, tested, and matched tubes. Neutrodyne sets are always re-neutralized with the tubes which are to constitute the radio-frequency and detector tube equipment of the receiver. For this purpose the special neutralizing adapter, marketed as an accessory to the Diagnometer for either four or five-prong tubes and sockets, is used in lieu of "dummy" neutralizing tubes. This adapter provides a means for neutralizing a radio-frequency stage to the tube which remains in that stage for the operation of the radio, thereby removing the possibility of inefficient neutralization through the use of a "dummy" tube, the inter-electrode arrangement and capacities of which may not match those of the tube which will normally operate in the neutralized stage.

Checking Condensers

After neutralizing, the tuning condenser adjustments are checked by means of one of the output meter synchronizing methods, such as the a.c. voltmeter method which is recommended in the service literature of some of the leading radio manufacturers. It is an excellent method, the a.c. voltmeter being rugged and the current required for a full low-scale deflection (about 100 milliamperes) being safely beyond the full-load output of any commercial power tube. With the model 400-B, the output of the moving-coil speaker terminals of the receiver may be connected directly into either of the low-scale movements of the a.c. voltmeter of the Diagnometer, or the output may be coupled to the meter through the primary and third windings of a special built-in a.f. transformer.

The thermocouple output meter synchronizing method available in late models offers the advantage of enabling the operator to control the range of deflection on the meter during the procedure by means of the 30-ohm rheostat. For neutralizing and synchronizing, harmonics of the modulated oscillator are chosen within the frequency limits recommended by the manufacturer of the receiver under test.

The continuity testing methods available with the Diagnometer are very useful. The thermocouple method is especially valuable for a comparative indication of resistor values from 0.1 ohm to 20 ohms, enabling one to check accurately the center tapping of transformer secondaries and filament resistors, to locate short circuited variable or fixed condensers without removing them from their position across radio-frequency transformers, to locate poorly soldered joints, etc. The a.c. voltmeter, in series with one of the power transformer secondary windings, is useful for continuity testing and comparative measurements of non-reactive resistors ranging between 10 ohms and 100 ohms. The d.c. milliammeter in series with the plate supply of a rectifier tube is used for continuity and comparative resistance measurements in non-reactive circuits of from 150 ohms to 30,000 ohms. Resistances up to several megohms can be calculated from readings obtained with the d.c. voltmeter in series with one or more B batteries. This hook-up is also useful in detecting

(Continued on page 245)

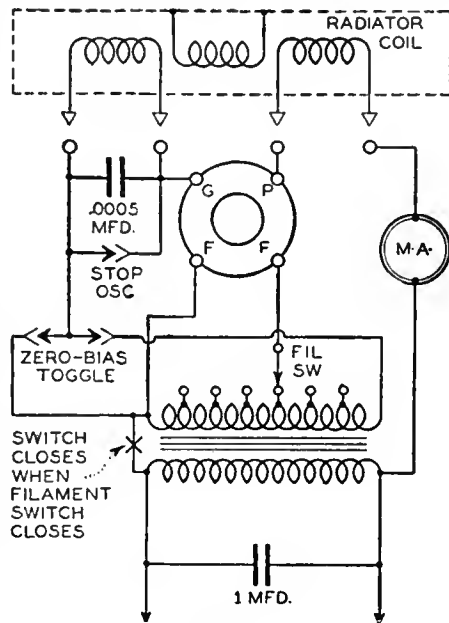

Fig. 1

PUSH-PULL A.F. AMPLIFIERS

By J. M. STINCHFIELD

E. T. Cunningham, Inc.

THE ALMOST universal adoption of the push-pull output stage for loud speaker operation indicates that it must possess advantages from the viewpoints of economy of design and performance. These advantages probably outweigh any consideration of the amount by which the maximum undistorted power output may be increased beyond twice that obtainable from a single tube. It is, however, interesting to see how much power output can be obtained from the push-pull stage and what distortion will result. Reproduction of voice and music having not over 5 per cent. harmonics added to the original is generally admitted to be distortionless high-quality reproduction. As a matter of fact, by comparing the original sound by means of a quick change-over switch with the reproduced sound containing 10 per cent. of harmonics, it was difficult in the experiments described to hear any audible difference in quality. It was also difficult to determine whether second harmonics are more or less objectionable than third harmonics.

Measurements of the undistorted power output are usually determined for 5 per cent. of harmonics and no grid current flow. Until the signal voltage is large enough to start a flow of grid current, practically the entire harmonic output of a single three-electrode tube is second harmonic. When two tubes are connected in a push-pull circuit the second harmonics and all even harmonics introduced by the tubes should largely balance out in the output circuit leaving only harmonics which are odd multiples of the signal frequency.

When a sine wave of signal voltage is applied to the grid circuit of a single tube and gradually increased in value, the wave-form of the current in the load appears to be a sine wave initially, and then gradu-

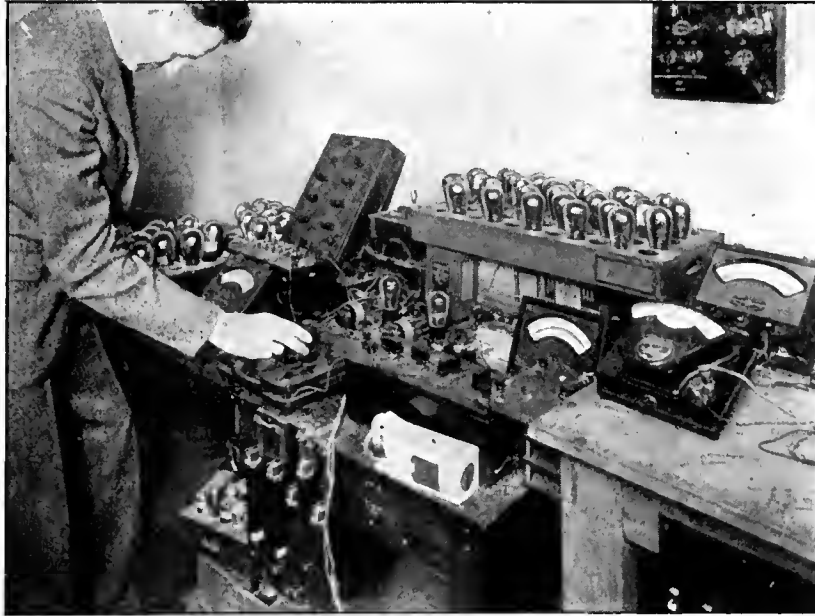

The author at work in his laboratory.

ally flattens on one side and continues to rise on the other side. This effect is most noticeable when the load resistance is about equal to, or less than, the tube resistance. Fig. 1 shows such a wave-form. It is equal to the sum of a sine wave and

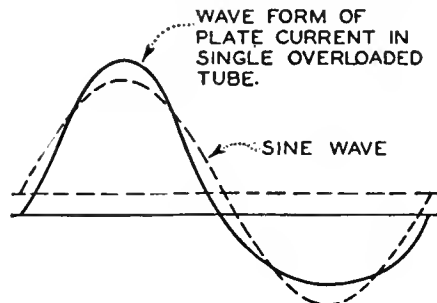

Fig. 1

a second harmonic. The dotted curve in Fig. 1 is the sine wave. If a sine wave of signal voltage is applied to the grid circuit of Fig. 6 the wave-form of the output

current appears to be a sine wave until the signal is quite large. The load resistance had very little effect on the wave form.

To determine how the distortion increases with increasing signal voltage, two 6X112A tubes were connected in a push-pull circuit as shown in Fig. 6. The signal voltage was taken from the 60-cycle supply and was connected through a low-pass filter to eliminate harmonics, so that a 60-cycle sine wave of voltage was applied to the grids. The wave form of the output alternating current through the load resistance, R_p , was observed on a G.E. oscillograph. The meters for reading the effective d.c. grid voltage, E_c , and d.c. plate voltage, E_p , each consisted of a million-ohm wire-wound resistor and a microammeter so that

they could remain permanently connected. Some of the oscillograms were analyzed by measuring the ordinates at 12 equally spaced points per cycle and computing the coefficients for a Fourier series.

The inductance across the output (plate to plate) was about 180 henries. The exact value depended, of course, upon the a.c. and d.c. values through the chokes. The impedance measured 98,000 ohms when 100 volts at 60 cycles and no d.c. were applied and 123,000 ohms when 200 volts at 60 cycles and no d.c. were applied across the inductance. The tubes for these tests were similar in a.c. characteristics. A preliminary check showed that the plate currents and grid currents were nearly the same for each tube. On other tests we found that tubes with matched plate current and a.c. characteristics showed nearly the same percentage of distortion as with two tubes with plate current and a.c. characteristics as much different as could be found in normal good tubes.

A 1.5-mA. meter (not shown) was used with a battery and low-resistance potentiometer in series with the load to balance

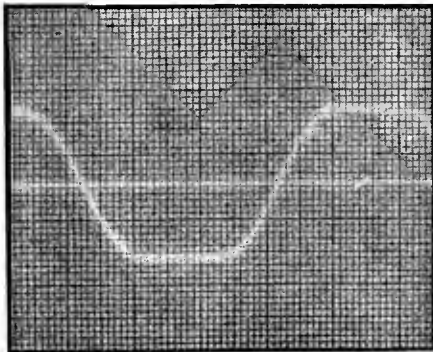

Fig. 2

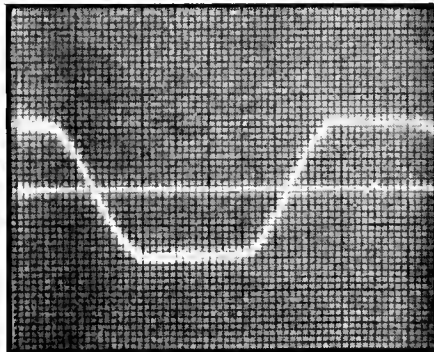

Fig. 3

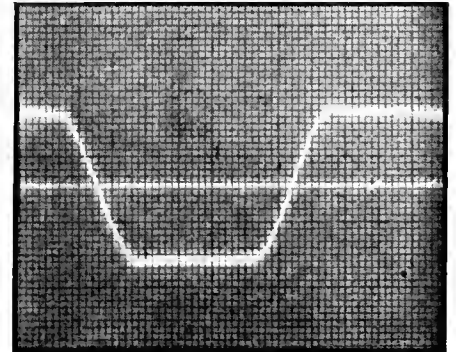

Fig. 4

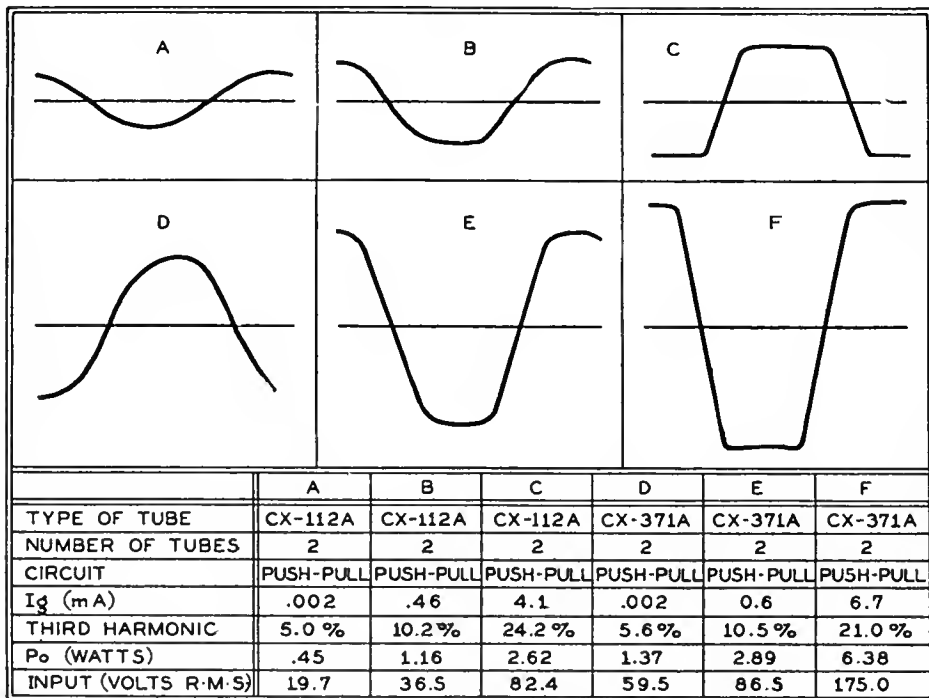

Fig. 5

produced and the second harmonic distortion will not increase in direct proportion to the signal voltage.

These tests were repeated with two CX-371A tubes. Fig. 5 (D, E, and F) shows the wave form of the output current. The corresponding data are given in Table I. The results indicate, as in the tests with the CX-112A tubes, that for highest quality output the signal voltage amplitude should not exceed twice the normal bias voltage for the tube.

The load resistance required for maximum undistorted power output from a single tube, considering 5 per cent. of second harmonic as a criterion of distortion, is equal to approximately twice the plate resistance of the tube. In the push-pull stage the load resistance has less effect upon the percentage of harmonics. Since the maximum power output from a tube (or any source of power) is obtained when the resistance of the load equals the resistance of the tube (source), the maximum power output will be obtained from the push-pull stage when the load resistance equals the sum of the plate resistances of the tubes.

With the load resistance equal to twice the plate resistance of one tube and normal bias voltage, the distortion is usually negligible until the signal is large enough to start a flow of grid current. The flow of grid current lowers the grid-filament resistance of the tubes putting a load on the input transformer. In Fig. 6 the input impedance was shunted with two 10,000-ohm resistors. The effect of loading the input transformer was then eliminated. The data, Fig. 5 (A to F) in Table I, show an increase in the bias voltage due to the flow of grid current through the d.c. resistance of the input. Figs. 2, 3, and 4 and the data of the table show an interesting result due to the flow of the grid current through the impedance of the input circuit. Fig. 2 shows the wave-form of the output current when the resistances R in Fig. 6 are 100 ohms. The signal was 39.0 volts (r.m.s.), the d.c. grid current 1.05 milliamperes, and the output alternating current 10 milliamperes. The resistances R were then changed to 10,000 ohms. For the same signal voltage, 39 volts, the grid current was reduced to 0.45 milliampere and the output alternating current was reduced to 9.15 milliamperes (see Fig. 3). Increasing the signal until the d.c. grid current rises to 1.05 milliamperes, as it was initially, the required signal voltage is found to be 52 volts (r.m.s.) The output is 10.4 mA. a.c. The output is 8.3 per cent. higher than was obtained with the low-impedance input, though the signal voltage was increased 33 per cent. Fig. 4 shows the wave-form of the output current. It is apparent that the distortion also is greater. In other words, a low-impedance input circuit is to be preferred.

out a small fraction of one milliampere d.c. which flowed through it.

In some earlier listening tests we used resistors bridging the input and output to overcome a slight tendency to sing at some high frequency. While no difficulty was experienced with singing in the set-up shown in Fig. 6, we continued the use of bridging input and output resistors.

The percentage of harmonics registered by the oscillograph may be somewhat high because of loss of fundamental in the output inductances, but it is not believed that this discrepancy is very great.

In Fig. 5A is shown the wave form of the output current when 19.7 volts (r.m.s.) is indicated on the meter, E_g, in Fig. 6. The load resistance R_p was 18,100 ohms. The peak value of the 19.7-volt (r.m.s.) signal is 27.9 peak volts. This is slightly over twice the bias voltage which was 13.5 volts. Each tube was drawing about 2 microamperes of grid current.

On increasing the signal voltage the grid current increased rapidly and both the upper and lower peaks of the output current were seen to flatten somewhat. When the signal reached 36.5 volts (r.m.s.) each tube had an average d.c. grid current flow of 460 microamperes. (Fig. 5B.)

The r.m.s. plate current in Fig. 5A was 5.0 milliamperes and the power output 450 milliwatts, or 225 milliwatts per tube. In Fig. 5B the r.m.s. plate current was 8.0 milliamperes and the power output 1160 milliwatts or 5.15 times the output per tube obtained in Fig. 5A. Fig. 5C shows the result of increasing the signal to an extreme value of 82.4 volts (r.m.s.). The power output is 2620. milliwatts or 11.6 times the output per tube obtained in Fig. 5A.

The data and the results of an analysis of Fig. 5 (A, B, and C) are shown in Table I. The second harmonics in Fig. 5 (A, B, and C) in order of increasing signal, are, respectively, 2.6 per cent., 6.8 per cent., and 4.8 per cent. The percentage was calculated from the ratio of harmonic to fundamental. Considering second harmonics alone as a measure of the distortion,

the quality is good for any signal amplitude. The corresponding amounts of third harmonic were, respectively, 5.0 per cent., 10.2 per cent., and 24.2 per cent. The percentage of higher harmonics was relatively small. Evidently the third harmonic is the principal distortion component from a push-pull amplifier, the

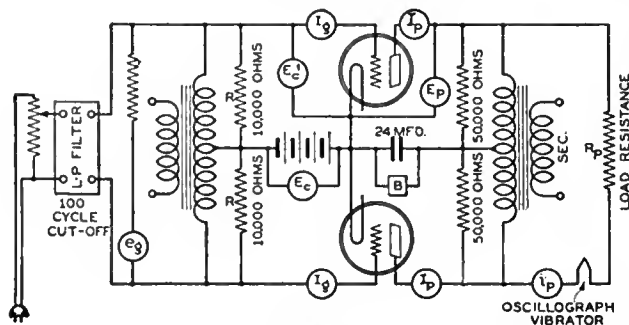

Fig. 6

percentage increasing (roughly) in direct proportion to the signal voltage. Similarly it will be found that with a single-tube amplifier the percentage second harmonic (principal distortion component) increases in direct proportion with the signal voltage. As the operation of the single tube extends into the grid-current region, or into the region of plate-current saturation, and the second derivative of the plate current with respect to plate voltage is negative, third harmonic distortion is

Table I—Data and Results of Analysis

Figure	D.C. Plate Cur. (I _p) Milliamperes	D.C. Grid Bias, (E _c) Volts	D.C. Grid Cur. (I _g) Milliamp.	Grid Signal (E _g) R.M.S. volts	A.C. Plate Cur. (I _p) R.M.S. Mil.	Power Output (2P R _p) Milliwatts	Per cent. 2nd	3rd	4th	5th
5A*	26.4	13.5	.002	19.7	5.0	450.	2.6	5.0	1.7	2.3
5B*	34.0	14.7	.460	36.5	8.0	1160.	6.8	10.2	1.8	2.0
5C*	46.0	21.4	4.1	82.4	12.0	2620.	4.8	24.2	1.3	0.9
5D**		40.5	.002	59.5	12.9	1370.	3.1	5.6	.3	2.0
5E**	60.	40.8	.60	86.5	18.7	2890.	.4	10.5	1.1	7.5
5F**	81.	56.7	6.7	175.0	27.9	6380.	1.2	21.0	1.3	3.7
2†	33.5	14.5	1.05	39.0	10.0	1612.	Input resistance 100 ohms			
3†	30.5	16.8	.45	39.0	9.15	1350.	10000 ohms			
4†	33.7	19.4	1.05	52.0	10.4	1745.	10000 ohms			

*2 - CX-112A tubes in push pull. E_p = +180 volts. E_c = -13.5 volts. R_p = 18,100 ohms.
 **2 - CX-371A tubes in push pull. E_p = +180 volts. E_c = -40.5 volts. R_p = 8260 ohms.
 †2 - CX-112A tubes in push pull. E_p = +180 volts. E_c = 13.8 volts. R_p = 16,120 ohms.

From now on—



THE set manufacturer to stay in business will be the one who plays safe by refusing to take the risk of using parts of uncertain performance or dependability. When competition whets its blade and selling costs go up, it becomes increasingly important to hold assembly costs as low as possible.

Take mica condensers for example. Unless capacity ratings are accurate, a terrible burden is thrown on the inspection department and "rejects" pile up until

they exceed the stock of usable condensers on hand. It doesn't require much imagination to picture what happens to production costs under such circumstances.

When you order Sangamo Condensers you need not make over-allowances for "rejects." The reliability of Sangamo ratings is attested to by a number of nationally known radio manufacturers.

And Sangamo is equally reliable as a source of supply.

SANGAMO High Voltage Condensers

Tested at 5000 volts d. c. and 3500 a. c. and built to Sangamo standards, known throughout the radio world, amateurs, commercial men and manufacturers have learned to depend on Sangamo High Voltage Condensers. Accurately rated and adequately tested—these condensers offer the maximum protection in high voltage, high frequency circuits.

SANGAMO ELECTRIC CO.

SPRINGFIELD, ILLINOIS, U. S. A.

Manufacturers of Precision Electrical Apparatus for 30 Years

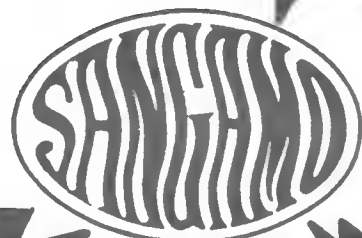

See Reverse

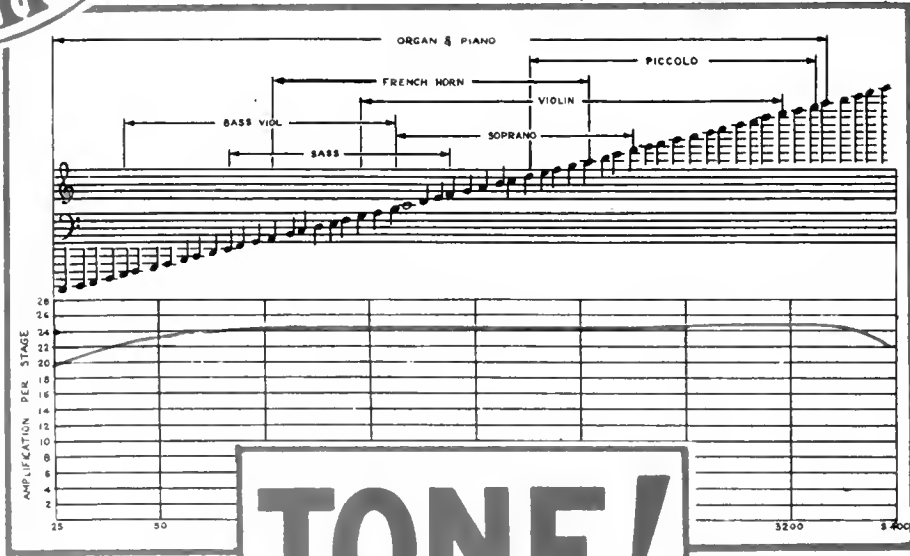
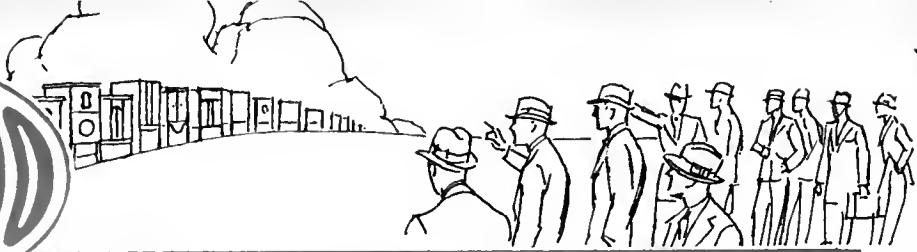
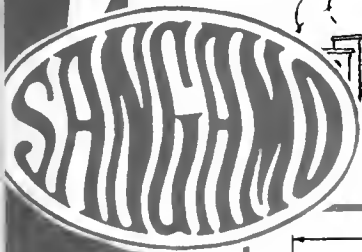

TONE!

Curve of Type "A" Sangamo Straight Audio Transformer showing uniformity of amplification at all audible frequencies.

What happens out on the "skirmish line"?

When your set goes up to the front line to meet prospective buyers—does it have an outstanding strategic advantage over competition or is it just a "long, hard pull" for your dealers?

Radio receivers must satisfy two different types of buyers. One is the amateurs who not only know the difference between good and indifferent performance but who understand what causes the difference. They are also an important recommending factor in the final purchase of all receivers.

The other type is not technical-minded but regards a radio receiver simply as a musical instrument.

To both classes *tone quality* is all-important. When a dealer tells an amateur that your set has Sangamo Transformers in the "audio end" he *knows* that the tone will be right. He also has more confidence in your set all the way through because he knows that no manufacturer who uses Sangamo Transformers will jeopardize their performance by using inferior parts elsewhere in the set. When equipped with Sangamo Transformers, your set need only be demonstrated to sell those who judge by ear alone.

Sangamo "A" Line Transformers are built for the custom set maker or manufacturer who wants a "tone" advantage over competition. The cost is slightly higher but is more than offset by the increased salability of the receiver.

"A" Line Transformers

- Type A straight audio amplification, list price, \$10.00
- Type B Push-pull Input Transformer for all tubes, list price, 12.00
- Type C-171 Push-pull Output, for 171 or 250 type power tubes with cone speaker list price, 12.00
- Type D-210, same as C except for 210 and 112 power tubes list price, 12.00
- Type H-171, Push-pull Output for 171 or 250 power tubes for Dynamic Speaker list price, 12.00
- Type G-210, same as type H except for 210 and 112 tubes, list price, 12.00
- Type F Plate Impedance for use as a choke to prevent oscillation and for impedance coupled amplifiers, list price, 5.00

Unusual facilities for furnishing transformers with or without cases ready for mounting and quick assembly with the receiver. Prices on application.



PIN THIS TO YOUR LETTERHEAD AND MAIL

SANGAMO ELECTRIC CO.
Springfield, Illinois, U. S. A., Dept. R

(For manufacturers) I am interested in engineering data regarding your transformers and condensers.

(For set builders) Please send circulars describing your apparatus and latest audio hook-ups. I in-

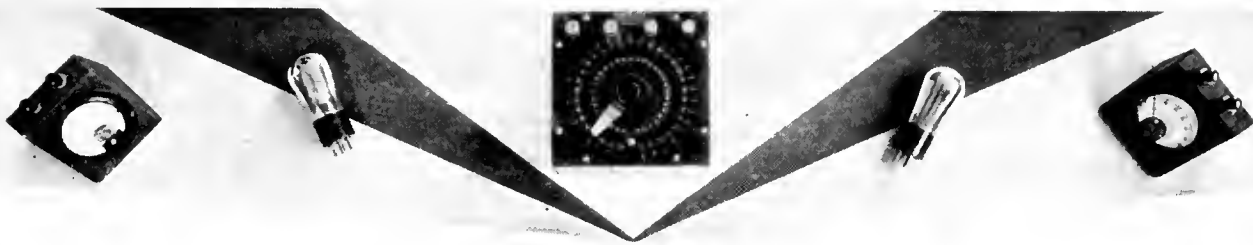

STRAYS FROM THE LABORATORY

A Radio Manual

The second edition of *Sterling's Radio Manual* contains much material that was not in the first edition. It is now a book of nearly 800 pages on theory and practice. It has material not generally available, such as the circuit diagrams and operation data on Western Electric transmitters of the latest type, receivers used for ship-to-shore traffic, and much other practical matter of interest and value to radio operators, engineers, servicemen, and others who want descriptions and other data on modern radio equipment. Airplane apparatus, beacons, automatic SOS transmitters, the International Laws relating to radio communication, the "Q" signals, tables of LC products, conversion tables of wavelength and frequency—all are in this big book with the soft covers. It is published by Van Nostrand and was edited by Robert S. Kruse.

Causes of A.C. Hum

The following statements are digested from an article in the *General Electric Review*, "The Operation of Radio Receiving Tube Filaments on Alternating Current," by Dr. K. H. Kingdon and H. M. Mott-Smith, Jr.

Hum due to operating a tube filament on a.c. comes from three sources,

1. a fluctuating potential drop along the filament.
2. a fluctuating magnetic field about the filament,
3. fluctuations in filament temperature.

Hum due the first cause is of two kinds, one having a frequency equal to the frequency of the supply voltage, and the other having a frequency twice that of the supply, e.g., for a 60-cycle supply, 60 and 120 cycles. The first can be balanced out by returning the grid and plate circuits to the proper place along the filament by means of a variable center-tapped resistor. The amplitude of the fundamental frequency hum is proportional to the ratios between the maximum value of the filament voltage and the approximate "lumped voltage" on the plate, while the second harmonic is proportional to the square of this value. Since this ratio is small, it is important to balance out the fundamental component of the hum.

A tube adjusted to minimum hum when the supply is sinusoidal will not be balanced if the supply contains even harmonics, although it will be in balance for odd harmonics in the supply. If the double-frequency component has been reduced—by proper construction and operation of the tube—to one tenth some given value, the introduction of a second harmonic of an amplitude of five

per cent. of the fundamental supply will cause an increase in the hum of 100 per cent. If the filament transformer also supplies power to a plate-supply unit variations in the load on the rectifier may cause considerable corresponding variations in the amplitude of the hum.

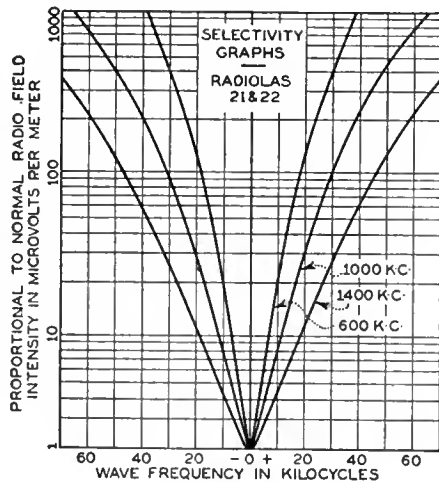

Fig. 1

It happens, fortuitously, that the hum due the magnetic field is opposite in phase to the hum due the first cause, and so a tube can be constructed and operated so that these effects partially balance out.

The third source of hum occurs only when the plate current is appreciable compared to the filament current, for example, if a 199-type tube with a 60-milliamperere filament is operated from an a.c. supply.

Calculations show that for a 226-type tube operated with a plate potential of 135 volts, the magnetic and potential ripple voltages will cancel out when the grid bias is minus 11.8 volts. However, in practice the hum voltage is of the order of 7 millivolts across a 26,000-ohm load.

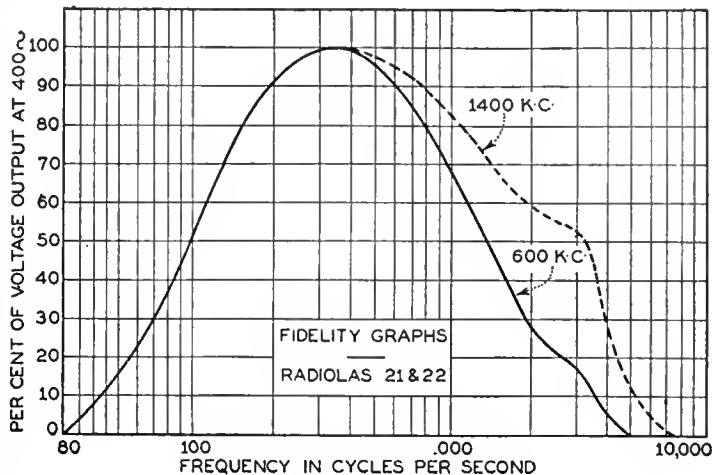

Fig. 2

The Radiola 21

In January, 1930, RADIO BROADCAST there appeared a description of the Radiola 21 and 22 battery-operated radio sets designed for the farm market. Figs. 1 and 2 on this page show the important characteristics of these sets; the selectivity at standard radio frequencies, 600, 1000, and 1400 kc; and the fidelity of response at two radio frequencies, 600 and 1400 kc.

The Radiola 21 is a table model, uses 5 tubes, and costs \$69.50; the Radiola 22 is a console model using the same equipment plus a Radiola 100B loud speaker. It sells for \$135.00.

All About Electricity

An excellent series of articles on the nature of electricity, originally published in *Power Plant Engineering* in 1928 and 1929 by Andrew W. Kramer, editor of that magazine, has been collected into book form under the title of *Electricity, What It Is and How It Acts*. In a small volume the author seems to have collected more material than ordinarily goes into a book of double its size. It is most readable by those who think they know what it is all about and by those who admit they don't know much about electricity. In other words, it is a book that tells you all about electricity, whether you are a power engineer or a tyro in the field of communication. The illustrations are of the simple and graphic form that many serious writers seem afraid to use. We recommend the book highly. The publishers are Technical Publishing Company, 53 West Jackson Blvd., Chicago.

Wire Communication

A book of interest to those who work with wire communications instead of the more, in the popular mind, "wonderful" radio medium is Shea's *Transmission Networks and Wave Filters*. This is the most recent of the already-long series of books known as the *Bell Telephone Laboratories Series*. It deals with the calculation and design of telephone networks and wave filters. In addition mathematics and electrical theory have not been neglected; in fact, a radio man looking at this book will be amazed to learn how simple his own mathematics are compared to what a full-fledged telephone engineer must wrestle with. One entire section of the book (there are three in all) is devoted to transients. Others deal with terminal networks, losses due to impedance mismatching, filters of all types, Fourier series analysis, etc. The book is published by Van Nostrand.



TWO BOOKS FOR ENGINEERS

ELEMENTS OF RADIO COMMUNICATION, by John H. Morecroft, 269 pages, John Wiley & Sons, 1929, \$3.00.

RADIO TELEGRAPHY AND TELEPHONY, by Rudolph L. Duncan and Charles E. Drew, 950 pages, John Wiley & Sons, 1929, \$7.50.

Here are two new volumes, both broadly concerned with radio technology, both issued by the firm of John Wiley & Sons, and both presenting a valid claim for admission to the progressive radio engineer's library, yet differing considerably in their contents and mode of presentation. The difference in contents would follow naturally, of course, from the fact that the two books are issued by the same publisher at about the same time. Another point of similarity is that all the authors are well known as radio educators, although in different fields. Morecroft is professor of electrical engineering at Columbia University, and author of the classic *Principles of Radio Communication*. Duncan is director of the Radio Institute of America, in which Drew occupies the position of instructor in radio.

The Duncan-Drew work is almost as long as Morecroft's *Principles of Radio Communication*. The difference between the two books may be inferred from the statement that a professional radio engineer, if he could secure only one of them, would unhesitatingly choose the *Principles* while a radio serviceman or operator would be likely to pick the work of Duncan and Drew. This is consistent with the object of the authors, and the fields in which they have done their work. Similarly, a student radio engineer would naturally take to Morecroft's *Elements*, although he might also get valuable material out of *Radio Telegraphy and Telephony*. He would find in all of Morecroft's writings a firm, highly evolved theoretical grasp of the type which forms the only reliable basis for practical results in engineering, and less concern with the details of contemporary equipment. The tendency of Duncan and Drew is to present the elements of the subject in much detail and to break down all subjects into easily comprehended fundamentals, and then to leap directly to lengthy apparatus description.

Radio Telegraphy and Telephony starts off with a brief introductory chapter which is rather badly arranged. The following chapters are concerned with the elements of magnetism and electricity, motor-generators, meters, storage batteries, etc. Chapter IX, a comprehensive review of the elements of alternating current theory, is followed by a treatment of "Condensers—Electrostatic Capacity—Capacity Measurements," preparatory to a hundred-page chapter on "Vacuum Tubes" and a 126-page chapter on "Receiving Circuits." Considerable text is devoted after this to alternating current receivers and tubes, and receiving accessories, especially loud speakers. Various commercial types, from the venerable 106-D to modern tube receivers in the communication field, are described at length.

With Chapter XVII the discussion turns to transmitting equipment. High voltage condensers, antennas, the phenomena of resonance, transmitter adjustment, and the characteristics of commercial broadcast and telegraph tube transmitters are considered in turn. Spark transmission is relegated to a place behind short-wave transmission and reception. The are trans-

mitter and the radio compass have later chapters of their own. The last chapter, XXVI, is concerned with "Radio Telephone Broadcast Transmitter Equipment," although much material on this topic is included previously in Chapter XX ("Commercial Broadcast and Telegraph Transmitters"). An appendix and index complete the text.

The somewhat confusing arrangement of broadcast transmitter material mentioned above is a characteristic fault of Messrs. Duncan and Drew's otherwise meritorious effort. The descriptions are badly arranged in places and give an appearance of imperfect digestion of the material. As a specific instance, the carbon microphone, including the broadcast type, is discussed on pages 610-614 of Chapter XX, while the condenser transmitter is described on pages 719-720 of Chapter XXI and again on page 894 of Chapter XXVI. Figs. 370 and 447A, in separate chapters, show views of condenser transmitters and stands differing only slightly in external design.

The fault of illogical arrangement is not found in the Morecroft text. At times the terminology is open to criticism, as when the author refers, on page 10, to "distorted waves," when he means complex or non-sinusoidal waves. Otherwise the book sustains throughout the impression of mature reflection on the author's part. The first three chapters present the underlying laws governing the behavior of audio- and radio-frequency circuits and the principles of radiation. "The Vacuum Tube and Its Uses" is the title of Chapter IV. Then follow chapters on radio telegraphy and radio telephony, and a final chapter, VII, on "Receiving Sets." Pages 257-266 contain, in small type, problems arranged by chapters. The index is somewhat brief.

Morecroft's *Elements of Radio Communication* contains no plethora of material, but at every turn Morecroft's wide physical knowledge is exhibited, to the profit of the student and even the experienced engineer. Such points as the calculation of the capacity of the earth on page 35, the fine range of comparative data in the discussion of "What Is a Good Vacuum?" on page 104, and the illustration, beginning on page 248, of how ordinary alternating current equations may be used to solve simple filter problems, are examples of this invaluable trait.

—CARL DREHER.

SERVICE MATHEMATICS

MATHEMATICS OF RADIO, by John F. Rider. Published by the Radio Treatise Company, New York. Price: \$2.00.

John F. Rider has promised a manual for servicemen for some time. It develops that there are to be two books. The first book contains the *Mathematics of Radio*; such is its title, and it has in it tables, formulas, and examples of radio circuits galore. The book tells how to solve all types of radio problems involving the three graces of radio, resistance, inductance, and capacity. It deals with power circuits, filament circuits, iron-core chokes, power amplifiers, screen-grid tube circuits, etc.

When a serviceman can work all the examples the author gives in this 127-page book, he can make up a few for himself, and be assured that he has a pretty good working knowledge of radio circuits. There is no better way to learn radio than by solving radio problems. It is a much

less expensive pastime than playing in a laboratory with sensitive meters and other apparatus that will burn or wear out.

The second volume of the *Service Man's Manual*, of which this book is the first, deals with commercial circuits and, according to the author, uses circuit diagrams of popular receivers and power equipment as the background of its work.

—KEITH HENNEY.

A THRILLING NARRATIVE

INTERNATIONAL ASPECTS OF ELECTRICAL COMMUNICATIONS IN THE PACIFIC AREA. By Leslie Bennett Tribolet, Ph.D. The Johns Hopkins Press. 282 pages. Price: \$2.50.

That a volume with this unpromising title should prove to be a thrilling narrative of cunning and intrigue was a surprise to the reviewer confronted with this assignment. The volume reviews the half-century of secret agreements and manoeuvrings which have hampered the establishment of American communications in the Pacific. Decentralized American interests, unsupported by a definite government policy, have faced foreign governments and hostile commercial interests with far-sighted plans, so far quite successfully carried out, to control trans-Pacific communications. Only the recent success of the Radio Corporation of America in establishing direct radio communication with Japan and the Philippines has bettered the American position. In contrast to the struggle on the Pacific, the eminently successful disposition of a four-corner competitive struggle of European and American enterprises in South America demonstrates how successfully unified international action has coped with an equally difficult situation.

The recent testimony before the Senate Interstate Commerce Committee considering the Couzens Bill, is ably supported by the experiences reported in this authoritative volume. The necessity for unified American policy in foreign international communications interests is so markedly brought out that any serious reader of this volume would regard as a misfortune any attempt to continue a competitive situation. The support which certain foreign governments give their commercial interests engaged in extension of international communication is an amazing contrast to the treatment accorded by our own Government to those active in this field. Experience has proved that the only reliable safeguard to uninterrupted international communication is the extension of American-owned cables and radio systems, working in coordinated and non-competitive harmony, aided and supported by an alert and forceful government policy.

—EDGAR H. FELIX.

PRACTICAL DATA ON TUBES

RADIO RECEIVING TUBES (Including Applications for Distant Control of Industrial Processes and Precipitation Measurements) by James A. Moyer and John F. Wostrel. McGraw-Hill Book Company, New York. 297 pages, \$2.50. 1929.

The partnership of Moyer and Wostrel is responsible for *Practical Radio* and *Practical Radio Construction and Repairing*, from the press of the same publishers. These books have been previously reviewed in RADIO BROADCAST. *Radio Re-*

(Continued on page 233)

Now D-C Tubes

by ARCTURUS

AND 2 NEW A-C TUBES GIVING
ARCTURUS DEALERS A COMPLETE LINE OF TUBES
FOR EVERY SET



PROVED PERFORMANCE
Demonstrate Arcturus' quick action, clear tone and long life... there will be no question which tube your customers will buy.

There's an Arcturus Radio Tube for Every Popular Set.

127	180
124	181
126	012-A
145	101-A
150	099
071	122
	071-A

YOU know what the name Arcturus means on an A-C tube. Quick action, clear tone, long life. This kind of service has made Arcturus Tubes famous throughout the radio industry... a symbol of dependable tube performance wherever A-C sets are made, used or sold... Now we offer Arcturus *Direct Current* tubes, built to the same high standards that made possible Arcturus' A-C superiority. In addition, 2 *new* A-C tubes have been added to the Arcturus line, giving dealers complete Arcturus equipment for any popular radio set... Thousands of Arcturus dealers know that Arcturus A-C quality has helped them increase their set and tube sales. Now, with a complete line of Arcturus Tubes for D-C and A-C sets, Arcturus offers better profit possibilities than ever before. Your business, too, can benefit by Arcturus' *proved performance*. Stock and sell the entire Arcturus line.



ARCTURUS RADIO TUBE COMPANY
Newark, New Jersey

ARCTURUS

LONG LIFE
RADIO TUBES



THE SERVICEMAN'S CORNER

Points on the Victor

Hum Potentiometer: "A Victor 32 operated satisfactory if the hum control in the R. P. A. unit was not adjusted to balance out the hum perfectly. Operation ceased when the hum was perfectly balanced out. The contact arm was deformed in such a manner as to permit it to make contact with the resistor strip at all points except at the exact center where the hum should have been negligible. As this resistor is the means of providing the grid return to the first a.f. tube, an open effectively disables the unit."

R. L. MINOR, O. K. Houck Piano Co., Little Rock, Ark.

NO PLATE VOLTAGE

"I had a Victor 'Micro-etc' with no plate voltage on the 226's. All the dope in the service notes and the diagram didn't help a lot.

"Another set was torn down to obtain actual values of resistors and other parts. This didn't do much good either and we went into a huddle with the circuit. Hey! Where's that other choke the service notes don't mention? It's the loud speaker! Absolutely right the first time. Another loud speaker did the trick.

"Another Victor oddity that will give a bad five minutes is two wire-wound volume controls ganged to one shaft. Maybe they are tracking together and then again—well look 'em over if volume seems spotty."

P. E. ROBINSON, Augusta, Me.

MECHANICAL HINTS

ARTHUR E. STARKWEATHER, of Starkweather Radio, dealer in Brunswick, Fada and Philco, of Chatham, Mass., still finds time to service Victors. He remarks: "Just a word to servicemen who might be called to service Victor 'Combs.'

"First: I want to say that it is not necessary to remove the tuning knobs or a.c. switch from panel to remove the set chassis as the panel pulls back with the chassis when the two wood strips are removed from in back.

"Second: Sometimes the tuning knob will only cover either the higher or the lower range of the dial and then will stick about one third the way across. This may be corrected by removing the tuning knob, taking a pair of heavy pliers and giving the tuning shaft a slight pull. This will allow the groove on the tuning shaft to snap into place on the tuning raceway."

Short Cuts to Neutralization

Balancing The Majestic Chassis: "I often run across a Majestic chassis that is very obstinate to balance. This is the way I go about it.

"First remove shield housing over the condenser gang. Remove all trimmer adjusting screws, and, with a pair of long-nosed pliers buckle the trimmer plate in the middle so that when the trimmer screws are replaced the center of the plate will come about $\frac{1}{8}$ inch away from its other plate. Proceed to balance set in usual manner with oscillator and resonance indicator,

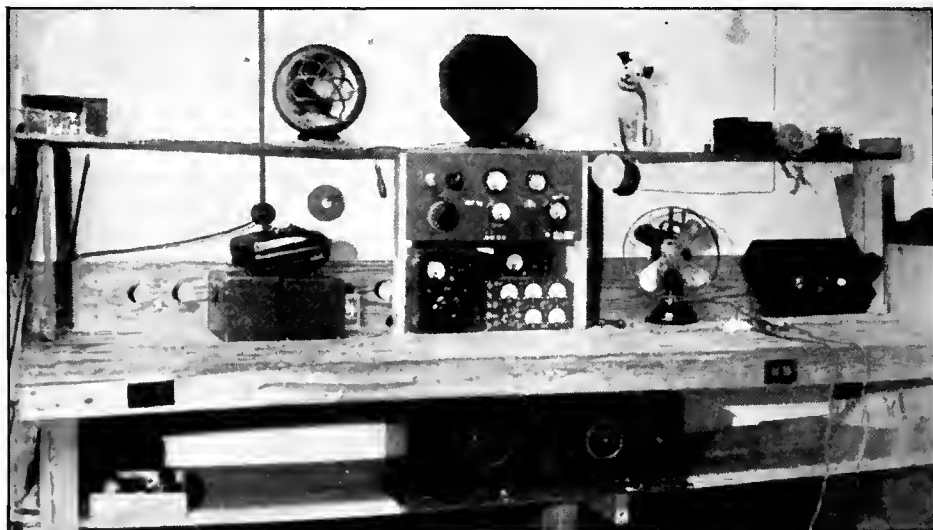

R. L. Minor, of the radio service department of O. K. Houck Piano Co., Little Rock, Ark., sends this photo of his laboratory with his contribution.

and by taking out the r.f. tubes stage by stage it is very easy to peak each stage.

"I have found this method to be very effective and it results in a highly efficient receiver."

H. A. GRATIX, Electric Service Laboratory, South Portland, Me.

RAPID NEUTRALIZATION

YERN PETERS, radio technician of Havre, Montana, contributes the following generalities on the technique of rapid neutralization:

"Most servicemen possess a diagnoser similar to the Weston Model 537. A set analyzer of this type may be used for neutralization, and for the lining up of condensers in a single-dial set. This is accomplished by using the tester as a

vacuum-tube voltmeter in the first a.f. or the output stage.

"The lead to the grid connection on the analyzer is broken, two leads are brought out, and clips are put on the end of them. By clipping the two leads together the tester may be used in the ordinary manner. On the Weston 537 the green wire is the grid lead.

"To use the tester as a vacuum-tube voltmeter, the leads brought out are connected to a C battery to place an additional bias on the tube so that it will act as a detector. On the 171A and the 245 tube I find $19\frac{1}{2}$ volts the proper additional C voltage required when they are used in push pull, and $22\frac{1}{2}$ volts when they are used singly. When the measurement is taken in the first a.f. stage $4\frac{1}{2}$ volts negative additional is satisfactory. Care should be taken not to overload the tube from which the reading is being taken. The plug from the set analyzer is inserted in the first or second a.f. socket and the switch on the tester is set to measure plate current. The tube is put into the socket on the tester.

"A modulated oscillator is necessary to furnish a signal. To line up sets with compensating condensers it is only necessary to adjust for the highest reading on the plate milliammeter. For neutralizing the conventional dummy tube and lowest reading method is employed. For accurate results use the lowest scale possible on the plate meter."

SPARTON SETS

"The Sparton models 62, 63 and AC7 which were built about two years ago, have a radio-frequency amplifier system which is so much different from the general run of T. R. F. sets, that a serviceman must understand the principles of its operation before he can successfully resonate the tuned circuits or neutralize the set.

"I have seen a serviceman work steadily for three hours with an oscillator trying

(Continued on page 228)

In the Department this month we publish a short article describing how an alarm clock can be used to turn a receiver on and off automatically.

This clock device is an elementary remote-control proposition. The problems of remote control should be cropping up in the serviceman's routine more and more consistently this radio season. In their more simple ramifications, remote-control jobs include turning a receiver on and off from different rooms, and adjusting volume, generally with two or more loud speakers operated simultaneously or singly from one receiver. The more complicated problems involve remote tuning.

We solicit contributions from servicemen whose efforts have been applied in this direction.

—THE EDITOR.

SM

How Somers Sells Satisfaction in Custom Receivers

F. B. SOMERS, General Merchandise
Saginaw, Michigan

Silver-Marshall, Inc., Chicago

A short time ago I built a set for a man who wanted "something good." From my experience with S-M kits I ordered the complete outfit, 712 tuner, 677 amplifier, and the 851 speaker.

I just delivered the set and I think I have "hung up" something for the "other fellow" to shoot at. At night I could register a station on every frequency in the broadcast band. Between nine and ten in the morning I tuned in WGY, WEAf, WCCO, WOC, KTNT, KMBC, WFAA, and WBAP. The last named is a little more than 1100 miles air line from Saginaw. This did not "just happen," as I repeated it several times and you could not tell the distant station from the nearer one by the volume.

I have built, remodeled and repaired hundreds of radios, including ten-tube supers, and this 712 is the first one to give me a real thrill. I am going to build one for myself now.—F. B. Somers.

The all-electric S-M 712 Tuner, with band-filter and power detector, stands far beyond competition regardless of price. It uses 3—'24 tubes and 1—'27. Price only \$64.90, wired, less tubes, in shielding cabinet shown. Component parts total \$40.90.

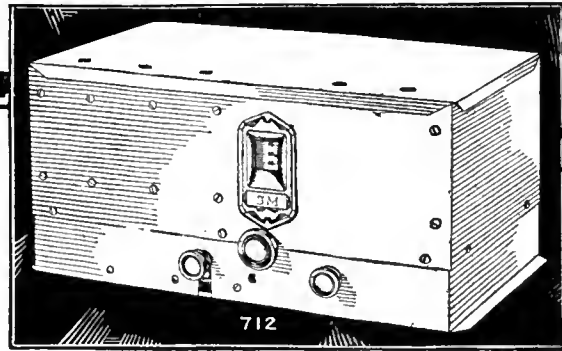

The new S-M 677 forms a perfect power supply, as well as an audio amplifier of appropriate superior quality, for use with the 712, or for records. Special input transformer has high ratio, ideal for phonograph pickup. Tubes required: 1—'27, 2—'45, 1—'80. Power comes from any 105 to 120 volt, 60 to 50 cycle source. Wired complete, less tubes \$58.50. Component parts total \$43.40. (For 25-40 cycle current S-M 67725 costs \$72.50 wired.)

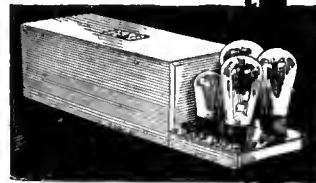

S-M 722 and 735 Show Marvelous Performance at Surprisingly Low Cost

The first complete a.c.-operated short-wave receiver is the new S-M 735, which costs, wired complete with built-in ABC power unit, less tubes, only \$64.90. Tubes required: 1—'24, 2—'27, 2—'45, 1—'80. Component parts total \$44.90. 735DC, for battery use, is also described completely in the new S-M catalog—see coupon.

Broadcast reception approaching wonderfully close to the 712's magnificent standard can now be had in the S-M 722 (using 3—'24 tubes, 1—'27, 2—'45, 1—'80) at only \$74.75 net, complete with ABC power unit, less tubes.

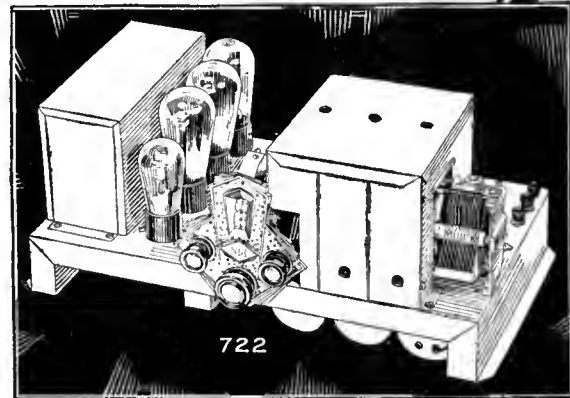

The handsome 707 table cabinet, finished in rich crystalline brown and gold, suitable for 722, 735, or 735DC, is only \$7.75.

If you are reading S-M's publication, the **RADIOBUILDER**, you're months ahead in your knowledge of what is going on in the S-M laboratories. Fill in the coupon NOW!

Custom builders have profited immensely through the Authorized S-M Service Station franchise. If you build professionally, write us.

SILVER-MARSHALL, Inc.

6403 West 65th St., Chicago, U. S. A.

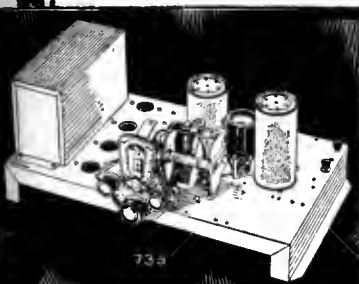

Silver-Marshall, Inc.
6403 West 65th Street, Chicago, U. S. A.

Please send me, free, the new Fall S-M Catalog; also sample copy of The Radiobuilder.

For enclosed.....in stamps, send me the following:

..... 50c Next 12 issues of The Radiobuilder

..... \$1.00 Next 25 issues of The Radiobuilder.

S-M DATA SHEETS as follows, at 2c each:

- No. 3. 730, 731, 732 Short-Wave Sets
- No. 4. 255, 256, etc., Audio Transformers
- No. 5. 720 Screen Grid Six Receiver
- No. 6. 740 Coast-to-Coast Screen Grid Four
- No. 7. 675ABC High-Voltage Power Supply
- No. 8. 710 Sargent-Rayment Seven
- No. 9. 675PD Phonograph-Radio Amplifier
- No. 10. 720AC All-Electric Screen-Grid Six
- No. 12. 669 Power Unit
- No. 14. 722 Band-Selector Seven
- No. 15. 735 Round-the-World Six
- No. 16. 712 Tuner (Development from the Sargent-Rayment)
- No. 17. 677 Power Amplifier for use with 712

.....Name

.....Address

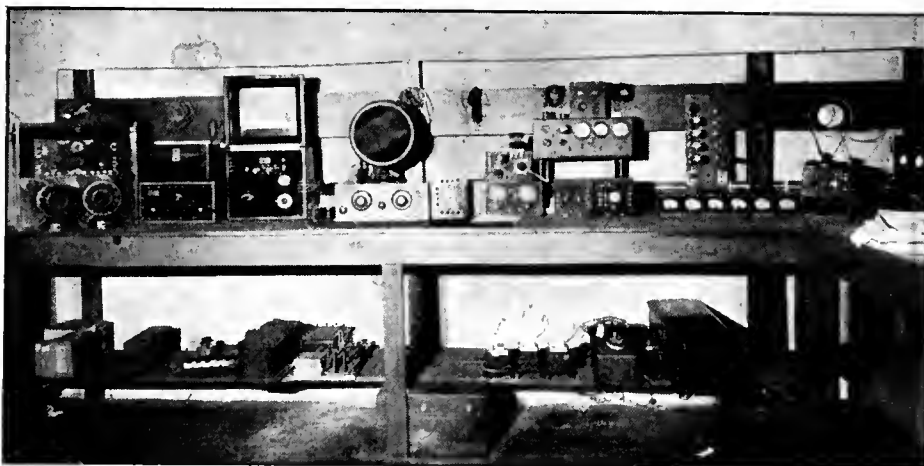

A new view of the Clarke Laboratories, Danville, Va.

(Continued from page 226)

to neutralize one of these sets, and, although he was able to balance out the oscillations in each stage, still the set would go into oscillation on certain parts of the band.

"Looking at the set from the bottom, a brass plate will be seen under three of the tuning condensers. This plate is insulated from the frame of the condenser by a very thin square of bakelite. On the side of each tuning condenser is a small leaf similar to a book-type condenser, which is adjustable. At first glance the serviceman will put these down as trimmer condensers, and here is where the big surprise comes in. Of the four tuning condensers equipped in this way, only one of them is connected as a trimmer condenser, and that one is in the detector input. On the other three, the brass plate under the tuning condenser is connected to the movable leaf, and this constitutes a variable radio-frequency bypass condenser to the filament.

"By choking off the r.f. currents from the C-bias lead, and providing a variable bypass to the filament, the engineers of this clever system have incorporated a lossier adjustment, which is necessary in conjunction with neutralizing, to prevent oscillations. This is probably necessary due to the fact that the set is unshielded, and although neutralizing will prevent coupling due to tube capacities, this still leaves the coupling due to coil feedback and circuit capacities.

"However, the main point of interest is how to adjust this system for maximum sensitivity, selectivity, and freedom from oscillations. Fortunately, the largest part of the job is the understanding of what goes on in the circuit. My method is to neutralize the set first. If it oscillates after this is done, I then loosen all the condenser plates very slightly, or until oscillation stops. Unfortunately these little by-pass condensers do act as trimmers at the same time, and this fact must be kept in mind. So if it were necessary to stop oscillation by loosening these condensers, and at the same time the circuits went out of resonance, I would re-resonate the circuits by continuing to loosen one or two of the condensers, as needed, until selectivity is regained. Then the circuit is reneutralized with the oscillator, and the job is done. If at first, after neutralizing the set, I find, instead of a tendency to oscillate, that the set lacks pickup and selectivity, I introduce more radio-frequency gain by tightening all the condensers a little. Care must be taken to keep the circuits in resonance at the same time. The adjustment is right when the set hisses slightly as it is tuned into a carrier wave, and tunes sharply. I finish by neutralizing again, and make a final check on the

resonance, by pushing slightly with a screw driver on the tuning condenser end plates.

"I have found that most of these sets can be tremendously improved by the intelligent use of these adjustments, and the customers are delighted in every case."

A. H. GOUD, So. Portland, Me.

An Automatic Switch

Try suggesting to some of your customers the utility and convenience of having their sets turned on or off automatically at a predetermined time. Your service editor finds it quite in accord with his general indolence to roll into bed at ten P. M., listen to the slumber music waft in from the living room, with the serene knowledge that it will turn itself off at midnight. More ambitious fans may put the device to the perverted use of an alarm clock, substituting setting up exercises for the bell.

VERNON W. PALEN, an engineer with the Telephone Company shows how easy it is to do.

"The clock described in the following paragraphs was constructed because a certain member of my family had the bad habit of falling asleep at night with the radio going. As a result, I found my batteries prematurely exhausted on several occasions.

"The time clock shown in the illustration effectively ended the above evil since it is always set to turn the radio off at some hour after midnight at which time the household is usually fast asleep and most radio programs are 'Off the air.'

"A dollar alarm clock furnishes the backbone of the mechanism. The clock is mounted in a small wooden box which is constructed to fit. A circular piece is cut from the front of the box through which the face of the clock protrudes. The rear of the box is then fitted with the switch mechanism.

"The face of the clock extending through the circular hole of the box helps materially to hold it securely in position. A strip of wood placed across the back of the clock and fastened to the box with screws holds the clock fast. It is convenient to mount the brass contact springs on the strip of wood above mentioned as

will be seen in the illustration, Fig. 1. "To the alarm winding key, a piece of sheet brass (bent 'U' shaped to give it rigidity) is either soldered or bolted. A wire is connected to each of the two stationary brass contacts and brought out to the radio set and these are used to connect the contacts in series with the A of the set supply or a.c. line. The brass contacts are adjusted so as to touch the brass arm on the alarm key when the key is rotated to wind the clock. The alarm is set in the usual manner and when the alarm sounds, the key rotates the contact arm, breaking the connection with the two stationary brass contacts. It will be noted that the brass arm on the alarm key will strike the side of the box after approximately a half revolution. This stops any further unwinding or ringing. A half turn of the winding key is all that is necessary to reset the switch since it never completely runs down.

"By a slight variation in the contacts, the device can be used to turn the receiver on at a given time.

"I finished the box in black lacquer and by means of the two screw eyes hung it under the edge of my radio table. There it serves conveniently as a safety device for my radio set and as a timepiece for the living room."

In the Service Laboratory

Determining Transformer Ratios: "As a rule there are several power transformers in operating condition laying around the service shop that have been taken from power packs, sets, etc. At a time when one of these transformers would come in handy for replacement on a rush job, the serviceman is often ignorant of its high-voltage characteristics. And as a rule the a.c. voltmeter at hand reads only to 150 volts.

"A quick and easy way to obtain the high-voltage reading is as follows. First measure the line voltage. Connect the secondary leads to the line. (In the case of a full-wave transformer, connect one outside terminal and the center tap.) Take a voltmeter reading across the usual 110-volt primary. The line voltage divided by the voltage across the primary will then give

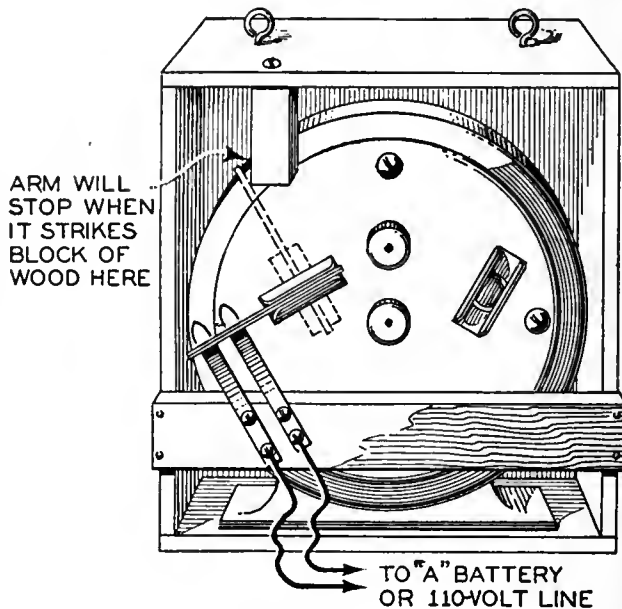

Fig. 1

the ratio of transformation. In other words, if the line voltage is 108 and the voltage across the primary is 36, the ratio is 3 to 1 and the transformer, when connected properly, will give 324 volts on the high side (108 volts times 3).

"The same method may be utilized to ascertain the ratio of an unmarked a.f. transformer. Connect line across the secondary and read the voltage across primary.

"It is always good policy to test for short circuit or grounding before proceeding."

JOHN H. STEURER, E. E., Rockville Centre, N. Y.

A NON-METALLIC SCREW DRIVER

The serviceman will often find use for a non-metallic screw driver, particularly in adjusting and aligning tuning condensers. E. G. CORTON, manager of the Quick Radio

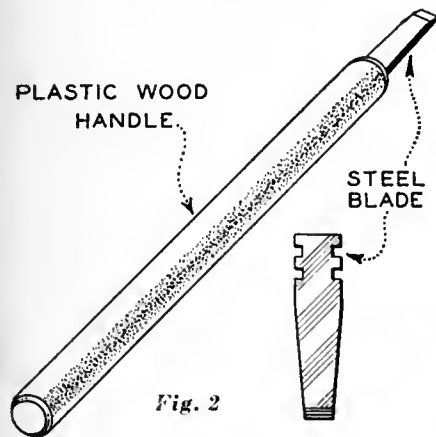

Service, of Norman, Oklahoma, suggests molding a handle of plastic wood and inserting a thin piece of steel in one end before the wood sets. The idea is sketched in Fig. 2.

SIMPLE TEST PRODS

"In making test prods I take two six-inch pieces of bus wire, round or square, solder same to the desired length of Belden Colorubber wire, and then slip a length of spaghetti over the bus. Cut the spaghetti so as to expose about an eighth of an inch of bus wire and, of course, long enough to cover the remainder of the bus wire and the soldered joint. Fasten the spaghetti to the insulation of the test wire with cement or by tying."

H. W. HUDELSON, Radio, Auto Service and Merchandise, Vandalia, Mo.

CALIBRATED CAPACITY METER

R. W. SHELTON, specializing in radio service, of Paducah, Ky., suggests a somewhat unusual addition to the serviceman's test equipment in the way of a simple calibrated capacity meter. The apparatus he describes is effective in measuring capacities between 0.1 and 12 mfd., and should prove most useful in determining the capacities of those filter and by-pass condensers that shed their labels like a duck does water.

"The calculation of capacity may be expressed in the following formula:

$$C = \frac{I \times 1000}{2\pi f E}$$

where C is the capacity in microfarads, I is the current in milliamperes, E is the voltage, and f the frequency in cycles.

"The number 100 readily lends itself to calculations, and, as it is may be obtained easily by dropping the conventional 110-volt house supply through a suitable resistor, 100 volts at 60 cycles will be used in making our measurements.

"The circuit is shown in Fig. 3. The milliammeter and the voltmeter are a.c. instruments having respective ranges of from zero to 500 mA. and from zero to 150 volts. The resistor, R, may be any convenient value that will drop the line voltage to 100 volts. A high-range power Clarostat is ideal for this purpose.

"To measure the value of a condenser, the first step is to ascertain that the con-

(Continued on page 231)

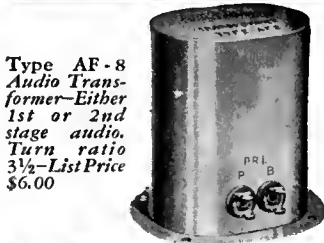

Type AF-8 Audio Transformer—Either 1st or 2nd stage audio. Turn ratio 3 1/2—List Price \$6.00



*AmerTran ABC Hi-Power Box—500 volts DC plate voltage, current up to 110 ma; AC filament current for all tubes for any set. Adjustable bias voltages for all tubes. Price, east of Rockies—less tubes—\$130.00.



*Complete 2 stage audio amplifier with first stage AmerTran De Luxe for UX 227 AC and second stage AmerTran Push-Pull for two 171 or 210 power tubes. Operates with 450 volt AmerTran Hi-Power Box. Price east of Rockies—less tubes—\$80.00.



AmerTran De Luxe Audio Transformer—List Price \$10.00. Type 151—Between one input and two output tubes—List Price \$15.00



AmerTran Power Transformer Type PF-245A—List Price \$22.00

*Licensed under patents of the Radio Corporation of America and associated companies for radio, amateur, experimental and broadcast reception.

Quality RADIO PRODUCTS

AmerTran Audio and Power Transformers and Amplifiers are designed for those who truly appreciate fine quality in radio reception.

Weakness in the audio system in many receiving sets results in failure to deliver full richness of tone along the entire scale. AmerTran Radio Products perfect the audio system and reproduce music and the speaking voice in true tone (without distortion at any volume) just as broadcast in the studio.

FOR DETAILED INFORMATION WRITE FOR THE FOLLOWING BULLETINS:

- BULLETIN 1084
AmerTran DeLuxe Audio Transformer
- BULLETIN 1087
AmerTran Audio Transformer Type AF-8
- BULLETIN 1088
AmerTran Power Transformer Type PF245A
- BULLETIN 1076-A
AmerTran Hi-Power Box Type 21-D
- BULLETIN 1075-A
AmerTran Push-Pull Amplifier Type 2-AP
- BULLETIN 1065
The Complete AmerTran Line.

AmerTran Quality Radio Products are sold by all good dealers, or direct if they cannot supply you.

AMERICAN TRANSFORMER COMPANY

Transformer builders for over 29 years

172 Emmet Street, Newark, N. J.

AMERICAN TRANSFORMER COMPANY, 172 Emmet St., Newark, N. J. R.B. 2-30

Please send me the following Bulletins (Check (✓) those you want).
Bulletin 1084 () ; 1087 () ; 1088 () ; 1076-A () ; 1075-A () ;
1065 () .

Name.....

Street and No.....

Town..... State.....

THE AMRAD MODEL 81 RECEIVER

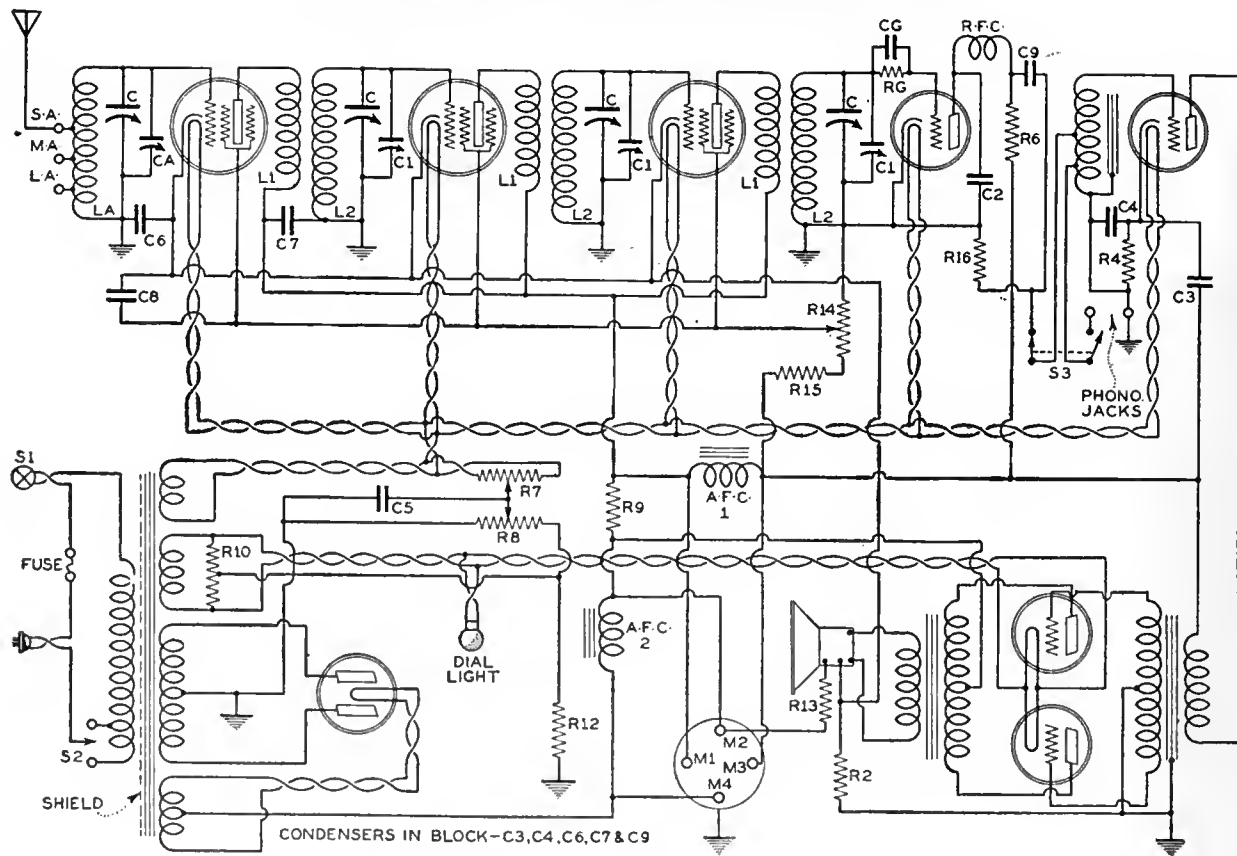

IN THESE notes on the Amrad Model 81 receiver we have two purposes, first to give a general description of the receiver and secondly to bring to the attention of readers the excellent service manual which has been prepared by the Amrad Company on this set. The manual contains some ninety pages which give valuable data on the importance of service and an excellent description of the engineering basis for the design of the Model 81. It is supplied in a leather binder and can be obtained for \$1.50 by writing directly to the Amrad Corporation. The following notes on the Model 81 have been obtained from the manual.

Three Screen-Grid Stages

The Model 81 receiver is designed to use three screen-grid tubes as radio-frequency amplifiers in special circuits of such characteristic as to match the operating characteristics of the screen-grid tube. In this way a design is obtained which gives the receiver a uniform sensitivity over the entire broadcast band, the gain actually varying less than ten per cent. The r.f. transformers are wound with a large number of turns on the primary, the winding being placed at the top end of the secondary. This type of primary does two things; first it gives higher amplification at 500 meters than at 200 meters, and secondly it changes the relation of the feedback due to capacity between leads so that oscillations are prevented by such couplings rather than assisted as is the case with ordinary radio-frequency transformers. The amplification per stage varies from 30 at 500 meters to 16 at 200 meters. This change in amplification is just the reverse of that obtained in the antenna stage, the result being uniform sensitivity. The overall gain up to the detector measures 23,000 at 500 meters, 28,000 at 300 meters, and 20,000 at 200 meters.

The Detector Circuit

A grid leak-condenser detector is used because a large number of tests by the engineering department of the Corporation indicated that its advantages more than offset its disadvantages. Some of the advantages which are obtained through the use of a grid leak-condenser detector are:

- A. Greater sensitivity
- B. Does not cause detector tube overloading provided sufficient a.f. amplification is used in order to make the output power tubes overload first.
- C. Has no appreciable effect on the fidelity as the selectivity of the r.f. tuning circuit starts to cut off high

audio frequencies before the grid leak-condenser detector starts to cut them off.

- D. The greater sensitivity of the circuit permits supplying the power tubes with maximum a.f. voltage without the possibility of overloading last r.f. amplifier tube.

The A. F. Circuits

Two stages of audio-frequency amplification are employed. Between the detector and first a.f. stage a special coupling system is used, the detector being shunt fed through a 100,000-ohm resistor, a tapped impedance being used in the grid circuit of the first a.f. amplifier tube and an 0.5-mfd. condenser functioning to couple the detector to the first a.f. tube. An r.f. choke and by-pass condenser are connected in the plate circuit of the detector to keep all audio-frequency currents out of the r.f. amplifier. The various audio-frequency components used in the set are

designed to give uniform amplification. This receiver has sixty-two per cent. as much output at 60 cycles, and twenty-five per cent. as much output at 4000 cycles, as at 400 cycles. The lower output at 4000 cycles is largely compensated by a rising frequency characteristic in the loud speaker used.

Volume Control

Volume control is obtained by varying the positive voltage supplied to the screen grids of the r.f. amplifier tubes. Reducing the voltage, of course, reduces the gain and thereby lowers the volume. The resistance unit used is of the graphite type which does not corrode and cause noisy operation.

In the receiver circuit two hum adjusting potentiometers are provided. The first potentiometer permits the adjustment of the amount of positive bias applied to the heater and the other provides a mid-point connection to the heaters.

READING WITH A SUPREME RADIO DIAGNOMETER

Type Tube	Tube Position	"A" Volts	"B" Volts	"C" Volts	Normal mA.	Screen-Grid Volts
221	1 R.F.	2.25	180	1.5	4.0	80
221	2 R.F.	2.25	180	1.5	4.0	80
221	3 R.F.	2.25	180	1.5	4.0	80
227	Det.	2.25	30	0	1.5	
227	1 A.F.	2.25	160	10.5	4.1	
245	2 A.F.	2.25	250	50.0	28.0	
245	P. P.	2.25	250	50.0	28.0	
280	Rect.	4.65			110.0	

Line voltage = 120. Set on 120-volt tap. Volume control in full-on position. Note: Hum-control potentiometer turned to ground side.

READINGS WITH JEWELL SET ANALYZER MODEL 198

Readings with Plug in Socket of Set and Tube in Tester

Type of Tube	Position of Tube	A Volts	B Volts	C Volts	Cathode-Heater Volts	Normal Plate mA.	Plate mA. Test	Plate Grid Change mA.	Screen Grid Volts	
224	1 R.F.	2.32	190	2.25	180	1.5	4.0	7.5	3.5	80
224	2 R.F.	2.32	190	2.25	180	1.5	4.0	7.5	3.5	80
224	3 R.F.	2.32	190	2.25	180	1.5	4.0	7.5	3.5	80
227	Det.	2.32	140	2.25	30	0	1.5	1.6	0.1	
227	1 A.F.	2.32	190	2.25	160	10.5	4.1	5.2	1.1	
245	2 A.F.	2.32	300	2.25	250	50.0	28.0	32.0	0.4	
245	2 A.F.	2.32	300	2.25	250	50.0	28.0	32.0	0.4	
280	Rect.			4.65			110.0			

Line Voltage = 120. Se. on 120 Volt Tap. Volume control in full-on position. Note: To get the 10.5 V reading (4-3) the hum-control potentiometer must be turned to ground side.

(Continued from page 229)

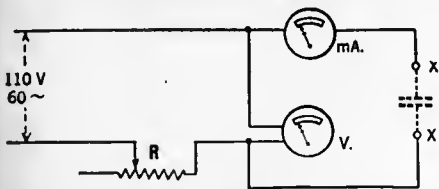

Fig. 3

denser is not shorted, by testing with d.c. and a high-resistance voltmeter. The condenser is then connected at the points marked "X" in Fig. 3, and the potential is adjusted to 100 volts. The reading on the milliammeter is noted, and the value of the condenser calculated from the formula given above.

"The capacity meter is, of course, easily calibrated, and Fig. 4 shows the calibration for a 100-volt 60-cycle current, the capacities at different current readings being indicated. In calibrating the chart for different voltages or frequencies, it is necessary only to obtain two points and connect them with a straight line, extending the line to the limits of the chart. Intermediate and extrapolated values will be indicated correctly on the line.

"It is, of course, possible to measure smaller condenser values by lowering the voltage and using a microammeter. However, for accurate measurements of small values a capacity bridge is preferable."

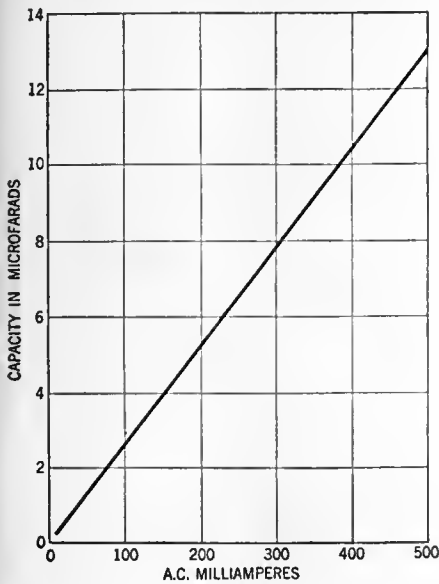

Fig. 4

RESONANCE INDICATOR

"The following arrangement may be readily built up in the average service shop and is most useful in checking the output of receivers and as a resonance indicator in aligning tuning condensers. The circuit is shown in Fig. 5. I use a Jewell 0-1 milliammeter and a fixed carborundum detector.

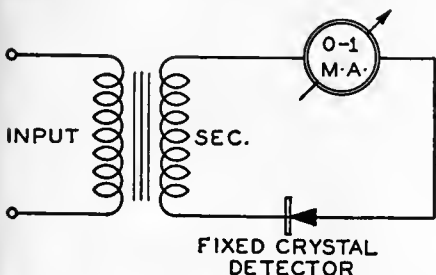

Fig. 5

The ratio of the a.f. transformer is four to one. An oscillator, of course, is used with the indicator for condenser adjustments."
O. E. FAULKNER, N. Little Rock, Ark.
(Continued on page 233)

SOUND REPRODUCTION

SINCE the inception of modern radio amplification the engineering laboratories of Thordarson have developed hundreds of transformers used in solving the problems of sound reproduction.

Standard units include those for coupling a microphone, a phonograph pickup or a radio tuner into any type of audio frequency amplifier.

Other units are available for coupling the output of an amplifier into transmission lines or directly into loud speakers.

Still other units allow coupling from any line into loud speakers or into additional amplifiers.

Your own work may be made easier and more profitable if you make use of Thordarson engineering service as applied to Thordarson transformers, chokes and amplifiers.

Tell us of your requirements and let us submit suggestions for an installation which will add to your good reputation.

THORDARSON

Transformer Specialists Since 1895

- Microphone Transformers
- Line to Tube, Tube to Line, Line to Line
- Mixing Transformers Coupling Reactors Filter Chokes
- Impedance Matching Transformers
- Speaker Coupling Transformers
- Complete Amplifiers

Thordarson Electric Manufacturing Company
Huron, Kingsbury and Larrabee Streets, Chicago, Ill., U. S. A.

SPARTON MODEL 301 RECEIVER

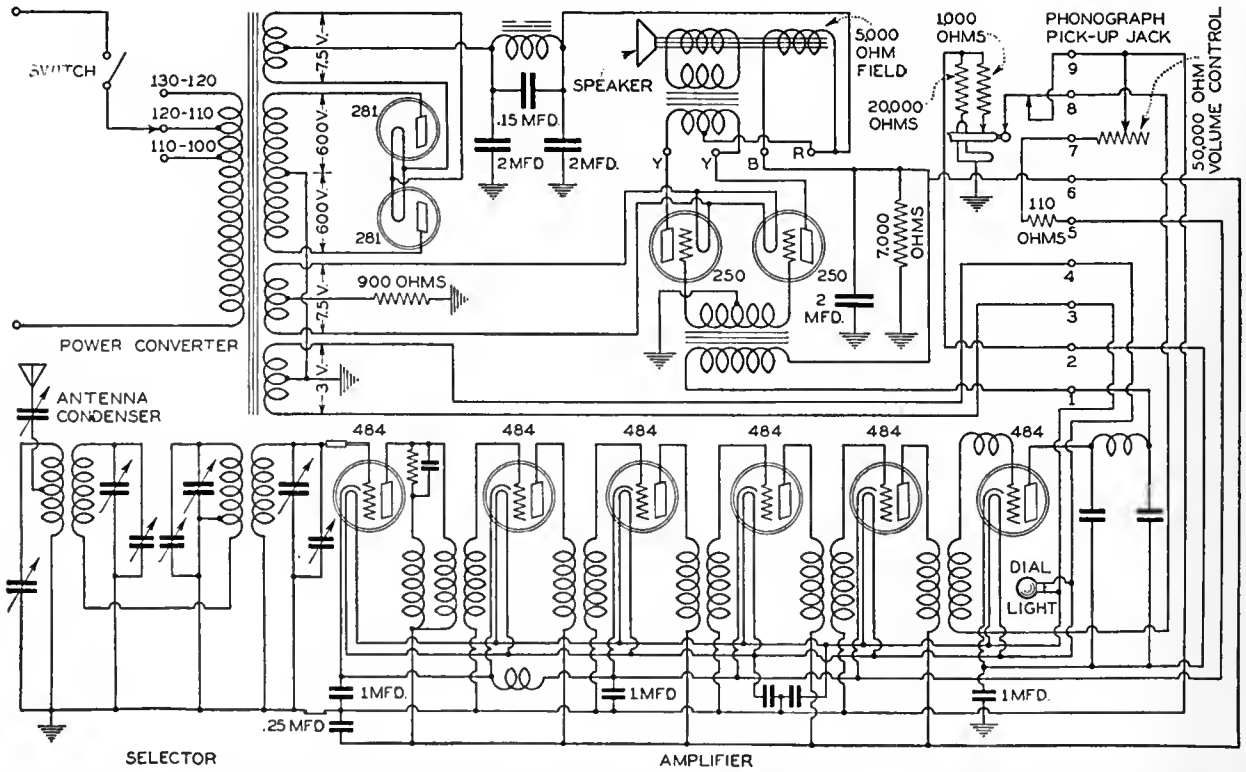

This receiver uses two 250-type amplifier tubes feeding into an electrodynamic loud speaker. In the filter circuit of the rectifier a tuned circuit consisting of a filter choke coil shunted by an 0.015-mfd. condenser is used. This circuit is tuned to the fundamental frequency of the output of the 280-type rectifier and eliminates practically all of the

ripple voltage. The field winding of the electrodynamic loud speaker constitutes the second filter choke coil. The schematic drawing shows how the untuned radio-frequency transformers are connected in the receiver circuit but it does not accurately indicate their unusual construction.

FADA MODELS 16, 17 AND 32

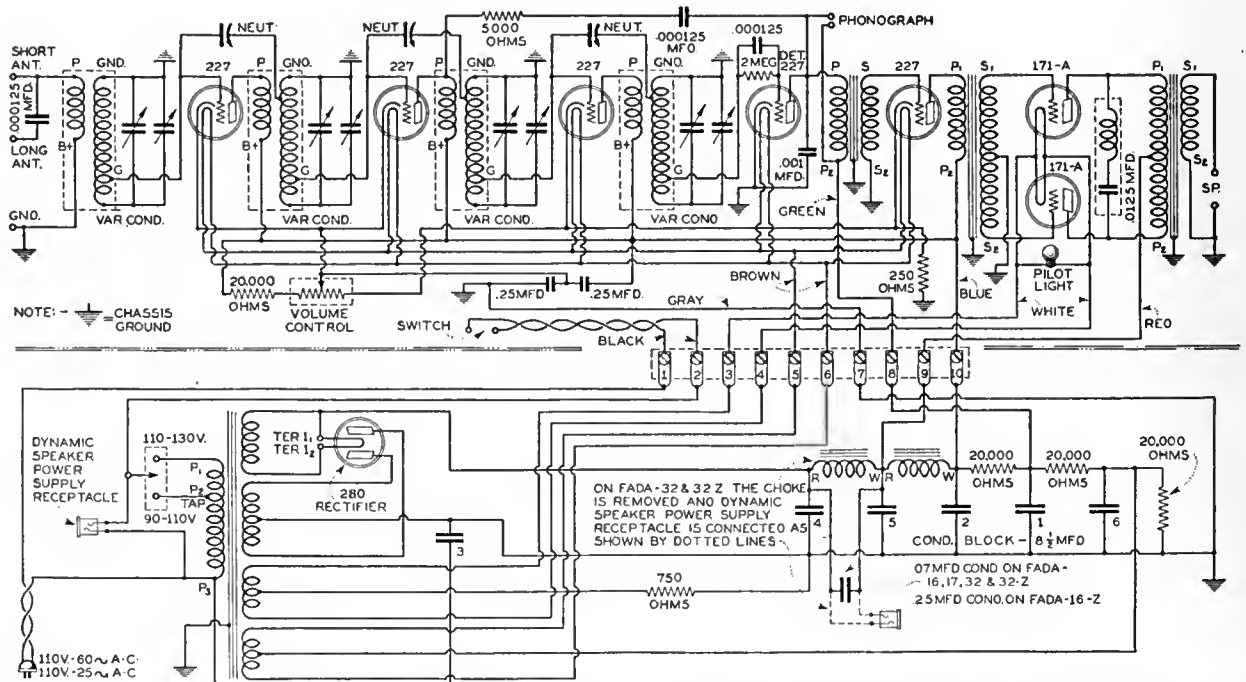

A three-stage tuned-radio-frequency amplifier is used in this set. It is interesting to note that the input circuits of the r.f. tubes are connected across only part of the tuned circuits. Neutralization is accom-

plished by connecting the neutralizing condenser from the grid of a tube to the secondary of the following r.f. transformer. The volume control is connected across the antenna-ground circuit.

(Continued from page 231)

Items of Interest

An Idea For Live Wires: L. M. Linde, of the Akron Radio Installation Service, contributes one of the brightest ideas that has found its way to the Service desk.

"We have found a successful means of securing more business for our installation department and believe that it can be applied by dealers in other cities.

"Through arrangements with a local public utility we have access to the names and addresses of people who are moving each day, and we solicit the installation of their antennas by sending them a post-card offering to erect an antenna and properly install their sets at a reasonable price.

"In this city of 200,000 there are about fifty families moving each day, and we find that we can get orders from about 10 per cent. of these.

"The cost of soliciting the business is very nominal for we use a government post-card with a printed announcement.

"We find that the income derived from this type of business aids considerably in maintaining our service department, and does not require additional help for the work can usually be done at times convenient to us."

OPPORTUNITIES FOR SERVICEMEN

A recent daily edition of a New York newspaper carried in its regular "Help Wanted" section sixteen advertisements offering positions to radio servicemen. This was not a radio section nor a special radio edition. The lowest salary offered was \$40.00 a week and the highest definitely mentioned was \$60.00. The average salary was \$50.00 per week. About half the jobs were on a straight salary and half on a drawing account and commission basis. Several positions promised rapid advancement to store manager.

The majority of jobs were offered by large concerns requiring servicemen in their radio departments. These were, for

the greater part, music dealers and department stores.

A driver's license was required in nine instances; a preference was indicated for a man with a car in six cases; and an automobile was essential in three jobs.

THE SERVICEMAN'S STATUS

The economic position of the serviceman in the radio industry was reasonably well established by the replies to the questionnaire sent out by the National Radio Institute. The N. R. I. explains the questionnaire as follows:

"On April 18, 1929, the National Radio Institute forwarded a questionnaire to a list of radio dealers doing business in every state. The questionnaire read as follows:

"We are trying to get some information about conditions in the radio business and send this to you as a representative dealer in your community.

"Will you be good enough to write your answers to the questions below and send this back to us in the enclosed stamped addressed envelope?"

"It is not even necessary that you sign your name. It is merely the information we are after and your hearty co-operation will be appreciated."

"A list of 1000 dealers was used and 283 answers were received—all from radio dealers actively engaged in the radio business, and all of whom gave answers to the questions asked. The answers, carefully tabulated, revealed:

"(1) That the 283 dealers employed 975 servicemen or an average of over four men to each dealer.

"(2) 45 dealers out of the 283, 17 per cent., do not have a service department but contract for service through outside organizations."

This is all rather corroborative in a general way of the replies to RADIO BROADCAST's own inquiries to establish the extent to which service departments were self supporting. The results indicate that about seventy per cent. of such departments more than pay their own way.

BOOK REVIEWS

(Continued from page 224)

ceiving Tubes is a practical work of the same nature, containing only enough theory to make the subject comprehensible, and crammed with immediately useful information and allusions to equipment in actual use. The object of such books is to teach radio servicemen, salesmen, operators, etc., the things they require in their daily business, and also to include within the limits of one volume a considerable amount of data useful to design engineers or specialists in other fields.

The historical introduction to *Radio Receiving Tubes* contains, on page 5, a picture of one of the antediluvian De Forest audions at which I gazed, first in glad recognition, then with a vague feeling of uneasiness which I traced back twenty years. This bulbular audion had the filament leads brought out to a standard miniature Edison lamp base, while the grid and plate terminals came out at the other end by means of insulated wires. Moyer and Wostrel, not being of the first generation of radio experimenters, illustrate the tube in an Edison base, filament outlet underneath. In those days, however, the good Doctor's filaments had a habit of sagging unless they were allowed to hang down, so we almost always suspended the tubes from a gooseneck fixture. The point may seem trivial, but I mention it because in 1910 the loss of five dollars through such an oversight was enough to bring most of us amateurs to the brink of suicide.

In the second chapter the authors plunge into constructional details, followed, in Chapter III, by a discussion of fundamental electrical relations, later applied in the chapter on "Vacuum Tube Action." The physics of boiling electrons off a filament is discussed, and such factors as mutual inductance, interelectrode capacity, etc., are considered for two-, three-, and four-element tubes. Reactivation and testing occupy separate chapters. Circuit considerations follow in the sections dealing with vacuum tubes as detectors, amplifiers, and oscillators. The chapter on "Specifications for Vacuum Tubes" contains useful numerical data.

The greater and best part of the last chapter on "Industrial Applications of Vacuum Tubes" is that dealing with telephone applications. The use of tubes in physical measurements, elevator control, electrical prospecting, etc., is also described, but more applications are omitted than included. Indeed, anyone who tried to enumerate and describe all the applications of even small vacuum tubes would have a large order to fill.

An appendix showing symbols generally used, and containing electrical data, with an index following, complete the contents of this text, which should find a ready sale among the numerous engineers, technicians, and semi-technical workers interested in the applications of lower power vacuum tubes.—C. D.

"Here at last is The Book that we of the Radio profession have needed for a long time. It is the best and most complete handbook ever published," says J. H. Bloomenthal, Chief Radio Operator, U. S. S. B. Steamship "East Side,"

THE RADIO-MANUAL

A New Edition

Complete new chapters on aircraft radio equipment; Practical Television and Radiomovies with instructions for building a complete outfit; radio interference; 100% modulation; latest equipment of the Western Electric Co.; the Marconi Auto-Alarm System; and many other developments of the past year. All this information is added in the new edition and, besides, the entire book has been brought right up to date with much new material. *The Radio Manual* continues to be the one complete and up-to-the-minute handbook covering the entire radio field.



A Handbook for Students Amateurs Operators Inspectors

20 big chapters cover: Elementary Electricity and Magnetism; Motors and Generators; Storage Batteries and Charging Circuits; The Vacuum Tube; Circuits Employed in Vacuum Tube Transmitters; Modulating Systems and 100% Modulation

Spark Transmitters; Piezo-Electric Oscillators; Wave Traps; Marine Vacuum Tube Transmitters; Radio Broadcasting Equipment; Arc Transmitters;

Spark Transmitters; Commercial Radio Receivers; Marconi Auto-Alarm; Radio Beacons and Direction Finders; Aircraft Radio Equipment; Practical Television and Radiomovies; Eliminating Radio Interference; Radio Laws and Regulations; Handling and Abstracting Traffic.

An immense amount of information never before available including detailed descriptions of standard equipment is presented.

Prepared by Official Examining Officer

The author, G. E. Sterling, is Radio Inspector and Examining Officer, Radio Division, U. S. Dept. of Commerce. The book has been edited in detail by Robert S. Kruse, for five years Technical Editor of QST., the Magazine of the American Radio Relay League. Many other experts assisted them.

Free Examination

The new edition of "The Radio Manual" has just been published. Nearly 900 pages. 369 illustrations. Bound in Flexible Fabrikoid. The coupon brings the volume for free examination. If you do not agree that it is the best Radio book you have seen, return it and owe nothing. If you keep it, send the price of \$6.00 within ten days.

Order on This Coupon

D. Van Nostrand Co., Inc.,
 250 Fourth Ave., New York

Send me the Revised edition of THE RADIO MANUAL for examination. Within ten days after receipt I will either return the volume or send you \$6.00, the price in full. (Radio Broadcast 2-30)

Name.....

St. & No.

City and State.....

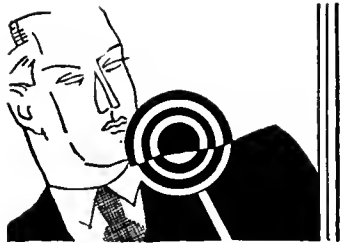

RADIO

RCA-RADIOTRON COMPANY ORGANIZED

New Company Will Take Over the Development and Manufacture of Vacuum Tubes for RCA-Victor Company

Manufacturing, engineering, research, and merchandising of RCA Radiotrons are now centered in a new corporation, a subsidiary of the Radio Corporation of America. It is called the RCA-Radiotron Company, Inc., and is headed by T. W. Frech as president. Mr. Frech was formerly a vice president of General Electric. Ownership of the company, it is reported, will be divided as follows: Radio Corporation of America, 50 per cent., General Electric, 30 per cent., and Westinghouse, 20 per cent.

Radiotron manufacture, it is said, will continue in the same plants as at present. Tubes in the past have been manufactured in various General Electric and Westinghouse plants with a large part of the production concentrated in the Harrison, Newark, and Bloomfield factories. The official announcement follows:

"As a reorganization of a part of the vacuum tube activities of the Radio Corporation of America, General Electric, and Westinghouse, a new company will be formed to be known as the RCA-Radiotron Company, Inc. Beginning with Jan. 1, 1930, the new company will carry on research activities, as well as the engineering, manufacturing, and selling activities in connection with vacuum tubes for use in radio receiving sets in the home entertainment field, now sold by the Radio Corporation of America and manufactured by the General Electric and Westinghouse Companies.

"The new RCA-Radiotron Company, Inc., will continue to receive full benefit, in its field, of the broad research facilities of the General Electric and Westinghouse Companies. The unification of vacuum tube development, manufacture, and sale in the new company will undoubtedly enable it to meet fully and effectively the responsibility of leadership which rests upon the founders of the radio industry in America. It will mean greater flexibility of manufacturing and closer responsiveness to the changing needs of the public and of the merchandising situation. It will make possible added economy in merchandising and manufacturing and will accelerate the commercial development of the great technical advances assured by the closer coöperation of the companies.

"The president of the RCA-Radiotron Company will be T. W. Frech, now a vice president of the General Electric Company."

"The formation of the RCA-Radiotron Company will in no way affect the present or future plans of E. T. Cunningham, Inc.," said George K. Throckmorton, executive vice president of Cunningham to RADIO BROADCAST.

The organization of the subsidiary tube

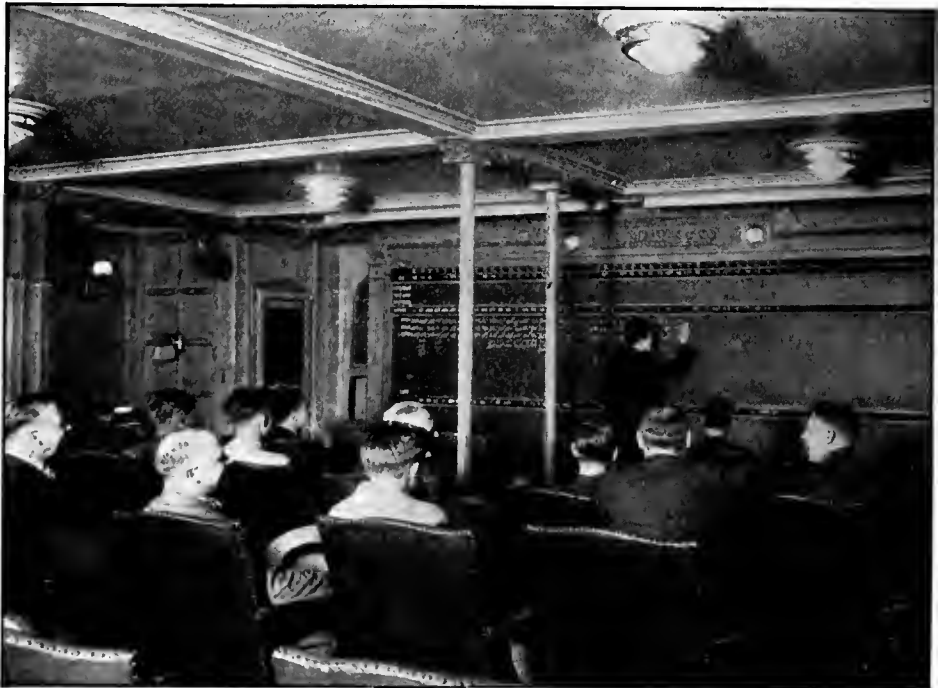

Photo courtesy United States Lines

Every day radio is proving of even greater aid to men in the business world. Now it is possible to cross the Atlantic on the Leviathan and at the same time be in constant contact with the latest financial news and a stock broker. The above picture shows the mid-Atlantic brokerage office of M. J. Mehan & Co., New York City

sales and manufacturing company by RCA follows closely on the organization of the RCA-Victor Company, also a subsidiary of RCA. The latter company will concentrate sales, engineering, research, and manufacturing in the Camden, New Jersey, plant, acquired from the Victor Talking Machine Company on its merger with RCA more than a year ago. Other subsidiaries of RCA, which is now purely a holding company, are: RCA-Communications, Inc. (national and international communication); Radio Marine Corporation (ship to shore communication); RCA-Photophone (sales and service, sound motion pictures); National Broadcasting Company (broadcast stations, network service, artists' bureau), Radio Music Company (including Carl Fisher, Inc., Leo Feist, Inc.). Of the above, RCA Communications and Radio Marine Corporation are wholly owned by RCA. RCA also has forty-nine per cent. stock ownership of the new General Motors Radio Corporation.

Contract for Radio Receptor

A Powerizer sound system will be installed in the United States Veterans' Hospital at Little Rock, Arkansas. The installation will include radio, phonograph pick-up, power amplifiers, loud speaker, and head phones. Centralized receiving sets will deliver programs to a central amplifying system.

Majestic Has Railroad Dept.

A railroad department has been organized under R. L. Maurer of Majestic. Sets are now installed in more than sixty of the nation's finest trains, according to the company. Frank A. Delano is head of the Majestic sales school now in regular session in Room 2500, Stevens Hotel, Chicago. The course lasts five days. Majestic's *Voice of the Air*, a rotogravure news-picture publication for general public distribution, reached a circulation late in 1929 on issue number 11 of 2,500,000 copies.

The 1930 Census

When the 1930 census is completely tabulated there will be definite figures on the number of radio sets in use throughout the United States. This was definitely settled early in December when William M. Stewart, director of the census, announced, among other additional questions, the inclusion of the following question:

No. 4. Radio Set? Yes— No—

Airplane Radio

More than 100 airplanes have been equipped with radio apparatus during the last year according to W. D. Terrell, chief of the Radio Division, Department of Commerce. Permits have been granted to 44 air ports for the installation of radio transmitters.

OF THE

INDUSTRY

Personal Notes

Stuart Mahaay, formerly radio editor of *The Country Gentleman*, and of the sales department of the Kolster Radio Corporation, is now managing editor of our contemporary, *Radio News*.

R. W. Bennett has recently joined the Trav-Ler Mfg. Corp., St. Louis, Mo., as vice president in charge of sales and advertising. For the past two years he was vice president and general manager of the A-C Dayton Company.

Edward K. Mac Ewan has been appointed secretary of the RCA-Victor Corporation. He was formerly a Victor official. Francis S. Kane (formerly of RCA) is assistant secretary.

Paul W. Morency has resigned as manager of field service of the National Association of Broadcasters to become general manager of the Travelers Broadcasting Service Corporation, owners and operators of station WTRC, Hartford, Conn.

O. F. Jester, formerly assistant sales manager, Radio Division, Stewart-Warner, has been appointed sales manager. He succeeds R. H. Woodford.

S. M. Doak is now general sales manager, United Reproducers. Mr. Doak was formerly Western district manager for Sonora.

Bethnel M. Webster, Jr. and Paul M. Segal have resigned as general counsel and assistant general counsel, respectively, of the Federal Radio Commission. Both attorneys will enter private practice of law in Washington.

Thad H. Brown, of Ohio, chief counsel of the Federal Power Commission, has been appointed general counsel of the Federal Radio Commission, it was announced recently. Mr. Brown, a former secretary of state of Ohio, succeeds Bethnel Webster, Jr.

Irma Lembke is the first television program director, according to the Jenkins Television Corp. Miss Lembke will have charge of the Jenkins radio-visual programs flashed from W2XCA and W3KX.

Corson Kneezel has been appointed advertising manager for the Kolster Radio Corporation. Mr. Kneezel was associated formerly with Evans, Kip, and Hackett, Inc., of New York, and previous to that with the Foster and Kleiser Company.

Carroll Van Ark, publicity manager for Kolster for a number of years, has resigned.

SARNOFF AND HARBORD REPORT BEFORE SENATE COMMISSION

The royalty payments due the RCA from some of the thirty-eight set manufacturers now licensed are in arrears \$561,621 said David Sarnoff, executive vice president of RCA, before the senate interstate commerce commission on December 14th in Washington, D. C. The committee is holding hearings on the bill introduced by Senator Couzens to establish a communications commission. Mr. Sarnoff went on to say that although there is no definite policy as to the licensing of manufacturers, the practice is not to license any additional ones because there "already is overproduction in the industry, we don't want to extend the licenses any more." On the whole, he said, the industry "is in fairly good condition" although certain licensees owe royalty payments to the extent of \$561,621.

Mr. Sarnoff admitted that the retail receiving-set business of RCA showed disappointing returns. "The Corporation," he declared, "has earned a smaller profit than its licensees have earned on their sets, after they have paid their royalties."

Describing the formation and growth of RCA, General Harbord, president, said during the course of his appearance before the senate committee: "As conceived and organized in October, 1919, RCA was a communications company. The great commerce in the entertainment field had then no existence. During the corporation's first year, 1920, radio in the entertainment field was the plaything of amateur operators. In that year RCA's sales amounted to \$500,000. During the next year broad-

casting had small beginnings and sales were \$1,500,000.

HOW SALES HAVE INCREASED

"In the seven years I have served the corporation," continued General Harbord, "its sales of radio apparatus have mounted from \$11,000,000 in 1922 to \$87,000,000 in 1928. Not radio telegraph devices but broadcast devices have brought about this vast increase. Radio telegraphy, its field originally conceived, has been responsible for a fraction over 9 per cent, whereas merchandising radio receiving sets, the field newly developed since RCA was created, has been responsible for over 86 per cent. of the corporation's total revenue from its organization up to June 30, 1929."

Saying that RCA's licensees have prospered, General Harbord declared that their sales in 1927 totalled \$46,000,000, in 1928 \$128,000,000, and during the first six months of 1929, \$64,000,000. "Some whose voices were once loudest in the chorus of denunciation have since become licensees, and their denunciation ceased with their licensing. Some remain but the goal they seek is not the remedy for which they ask you but licenses under the very patents they deery."

Speaking further of the license situation, General Harbord continued: "Under patents acquired and developed at vast expense, the Radio Corporation has elected to license many radio manufacturers, insisting always that an apparent ability to serve the public well should be a condition to the granting of a license. License fees are but the reasonable contribution of those who pay them to those whose efforts and money brought about the development and purchase of the inventions, joint use of which must be made in the manufacture of modern radio devices.

"Let this patent unification be at an end tomorrow," concluded General Harbord, "let each organization use only the radio patents it actually owns; let licensees operate only under their own inventions, and not use those licensed to them by others, and on that day will topple the whole structure of service which radio is rendering for the benefit and entertainment of the American public."

NATIONAL UNION MERGER

Discussing the recent formation of the National Union Radio Tube Corporation, Mr. Sarnoff said at the same hearing that RCA had acquired an option on the company's stock to the extent of 12 per cent. The corporation comprises four independent tube manufacturers now operating under an RCA tube license. The organization was arranged through bankers. These companies, Magnatron, Sonatron, Televocal, and Marathon, Mr. Sarnoff said, agreed to take a license under RCA patents and avoid litigation. Subsequently a loan of \$2,000,000 from RCA to the new

(Continued on page 236)

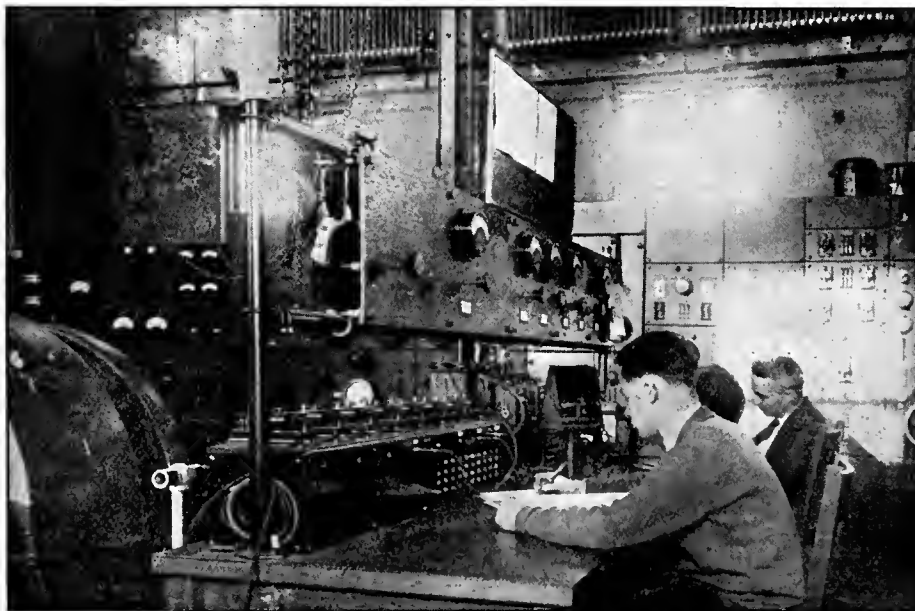

The famous pre-war German trans-Atlantic radio station at Sayville, L.I. has recently been modernized by the Postal Telegraph Company and is being used for transcontinental telegraph service. The operator's control table is shown in the above picture.

Service

Big Profits in it with Reliable Equipment

"A penny saved is a penny earned" is not true in purchasing instruments for radio servicing work. The small difference in cost between the best obtainable meters and those of secondary value comes back to you many times over in the money you can make and the business reputation you acquire through the use of reliable equipment.

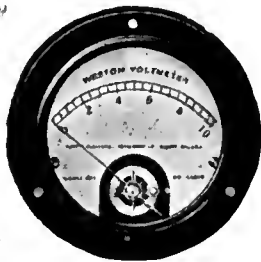

Shown herewith are two designs of miniature panel instruments—2" and 3 1/4" diameter—for use in the repair shop and in portable testing work. These are the instruments selected by Commander Byrd for his Polar expeditions. Preferred for their nicety of construction and superior electrical characteristics.

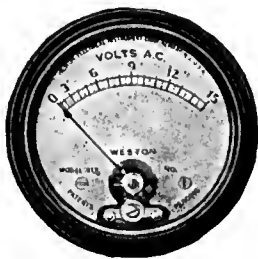

Made in A. C., D. C. and Thermo-Couple Types, and in all the required ranges. Open scales almost to zero position. Designed for flush panel mounting. Write for Circular JJ, containing complete descriptions and prices.



WESTON ELECTRICAL INSTRUMENT CORPORATION

(Continued from page 235)

corporation was made and this was secured by the option on National Union stock. At this point Senator Hawes of Missouri asked of Senator Dill the reason for this trend of inquiry into the financial activities of the corporation. Senator Dill replied that he had heard stories that the RCA was endeavoring to "browbeat" companies into effecting license agreements with it on patent infringement grounds but that the facts, as explained by Mr. Sarnoff, "disprove" these reports. In concluding, Mr. Sarnoff said that the 7 1/2 per cent. royalty on receiving sets is levied on the "full completed article," and not on the cabinet or chassis. RCA could have placed a 15 per cent. royalty on the selling price, he said, which represents about one half the cost of the radio set. Senator Couzens observed that the policy adopted by RCA is that it is better to charge a flat rate on the whole rather than a high rate on the chassis alone. This has been found effective in the automotive industry also, he declared.

Aerovox Sues Dubilier

The Aerovox Wireless Corp. sued Dubilier on patent number 1,736,764 on the use of mineral oil as a cooling agent in the manufacture of condensers. In addition to damages asked on the alleged infringement, a counter suit has been filed against Dubilier for damages totalling \$500,000.

Sonora Acquires Home Movie

Before the involuntary bankruptcy action brought against Sonora Products late in December, it was announced that the company had in production a home movie unit including motion picture projector, synchronized phonograph, and radio receiver. It was also announced that the company had a compact six- and seven-tube radio set for installation in automobiles.

DeForest Sues RCA

"Under the Clayton Act the DeForest Radio Company is entitled to triple damages for the period in which Clause 9 of the RCA contract with receiver manufacturers was in operation," said James W. Garside, president of DeForest, recently. The DeForest suit for damages, it was said, was not to bring about loss of RCA radio licenses as provided for under the radio act of 1927; but merely to press the suit for damages.

Radio Interference Manual

A 64-page booklet combining all engineering data secured by the Tobe Deutschmann Corporation on radio interference prevention and a catalog of Tobe apparatus for many special purposes in this connection has just been issued. Copies can be had at 25 cents each postpaid from the company at Canton, Mass.

Dayrad—a New Name

Radio service equipment manufactured by the Radio Products Company, of Dayton, Ohio, will, in the future, be made under the trade name Dayrad. E. T. Flewelling, formerly associated with the company, has resigned. Dayrad radio service instruments have been developed by an engineering personnel working independently of Mr. Flewelling and additions to the line will be announced shortly.

Bosch Dispute Settled

Settlement of litigation between American Bosch Magneto and Robert Bosch Magneto has been made. American Bosch secures the sole right to the use of the single word "Bosch" on automotive products, radio and all its other products in the United States, Canada, Mexico, Cuba, and American dependencies.

Remote Control Patents

As announced recently by E. F. McDonald, Jr., president of Zenith, the following patents are held by his company covering remote tuning and immediate tuning or the combination of both, providing that such tuning is done automatically.

Vasselli	No. 1,581,145—issued April 20, 1926
Heath	No. 1,638,734—issued August 9, 1927
Flocco	No. 1,591,417—issued July 6, 1926
Marvin	No. 1,704,754—issued March 12, 1929
Vasselli	No. 17,002—issued June 19, 1928
Gould	No. 1,695,919—issued Dec. 18, 1928

Production Figures

The Electric Specialty Company, Stamford, Conn., is increasing its manufacturing capacity approximately 40 per cent. through the construction of an addition to its Stamford factory. According to E. W. Berry, Esco's sales for 1929 will exceed those of their best year, 1928, by approximately 40 per cent. Officers of the company are: J. M. Wright, president; M. L. Bickart, treasurer; D. G. Shepherd, general manager.

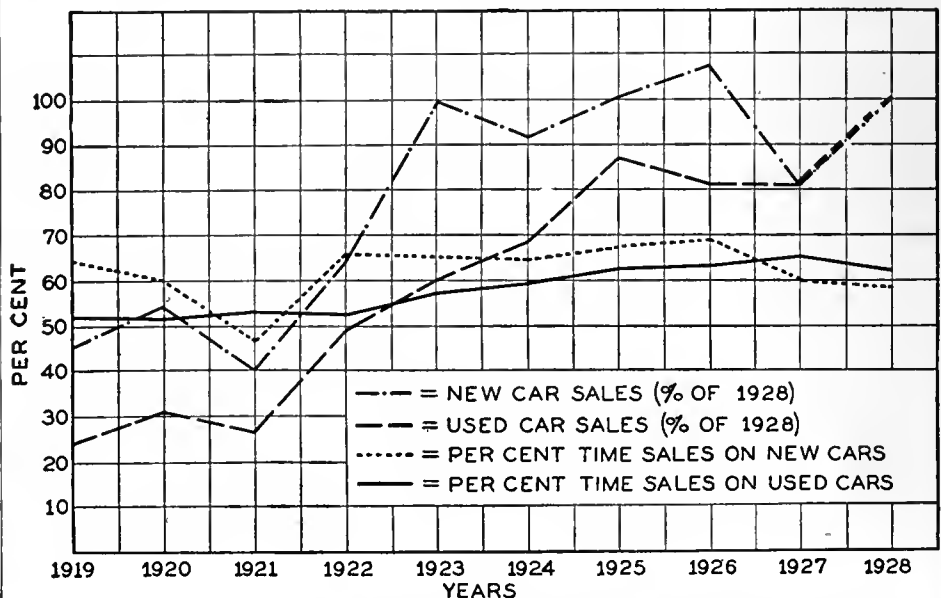

The curves in the above illustration show several interesting facts regarding the automotive industry, and, as the radio industry faces similar problems, a study of the graph should be of interest. The data for these curves were obtained from The Credit World, October, 1929.

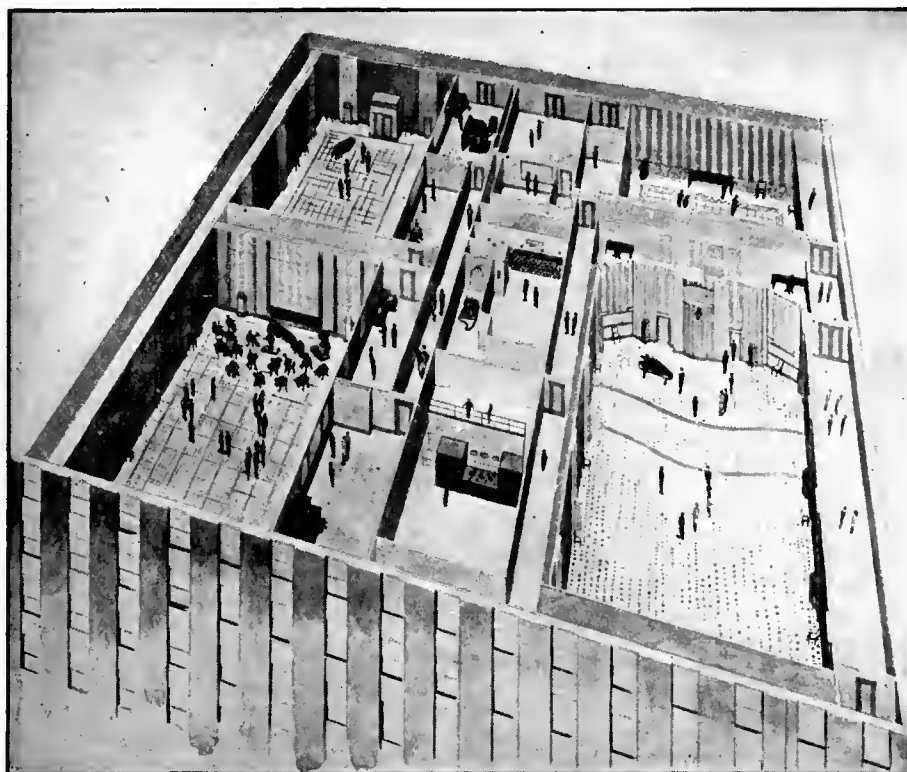

The National Broadcasting Company has made plans for installing the world's most pretentious radio studio atop the Merchandise Mart Building in Chicago. The drawing above indicates the arrangement of the studios which will occupy 10,228 square feet of floor space.

Industry Briefs

EARL SETS BOUGHT: Walter L. Eckhardt, formerly president of the Music Master Corporation, has purchased the entire stock of Earl sets from the receivers of the Earl Radio Corporation. This includes 9000 completed sets and 29,000 in the process of manufacture.

BRUNSWICK: The physical assets and patents of the Vitavox Company, manufacturers of sound-on-film devices, have been purchased by Brunswick.

PACIFIC RADIO TRADE ASSOCIATION: The second radio interference investigator has been employed by the P.R.T.A. through financial aid of Pacific Gas and Electric and Great Western Power Company. Four other San Francisco utilities now contribute to expenses of investigators. More than 350 complaints are handled monthly by the association.

TELEVISION DEMONSTRATIONS: The Baird Television Corporation, American headquarters, 145 West 45th Street, New York, demonstrated Baird's British system in December. Jenkins held a showing in New Jersey, early in January, with voice and picture actually transmitted to the demonstration receiver via radio.

NATIONAL UNION RADIO: A free course of instruction under Professor E. Gordon Taylor, College of the City of New York, for servicemen, engineers, and students in the New York area has been started by National Union.

AMERICAN STANDARDS ASSOCIATION: Among the radio standards agreed on and established during 1929 one fixes the dimensions governing the fit of four-pin vacuum-tube bases, it was announced.

INVENTOR DEAD: On December 12 Dr. James Harris Rogers, known for his work in radio under-ground and under-water communication, died in Hyattsville, Md., at the age of 79. A patent for under-sea radio communication was granted Dr. Rogers on May 13, 1919.

Doubles Size of Plant

The Leeds and Northrup Company, 4901 Stenton Ave., Philadelphia, doubled the size of their plant and increased the number of employees from 750 to 1150 during 1929. They make precision instruments, many of which are used in radio laboratories and factories.

Change of Address

DE FOREST: The executive offices of the DeForest Radio Company have been moved from the Jersey City plant to the main plant at Passaic, N. J. New and larger quarters are now available.

EBY: The H. H. Eby Mfg. Co. Inc., formerly located at 4710 Stenton Ave., Philadelphia, has moved into very much larger quarters at Twenty-Second St. and Lehigh Ave. This change was made necessary by a substantial increase in the Company's business during 1929. Plans are being formulated for even greater expansion during 1930.

SPRAGUE: Some time ago an announcement was made of the removal of the Sprague Specialties Company from Quincy to North Adams, Massachusetts. This removal, however, does not apply to the executive offices and laboratories which remain in Quincy.

Coming Events

February 10-11, 1930, Cleveland, Ohio. Fourth Annual Convention of National Federation of Radio Associations, Radio Wholesalers' Association, Statler Hotel.

Week of June 2, 1930, Atlantic City. Annual Trade Show and Convention Radio Manufacturers' Association. Convention Hall.

Dealers Association Formed

Seven radio dealers of Auburn, Indiana, have formed the Auburn Radio Dealers Association. Orris Wise, local Crosley radio dealer was responsible for its organization.

(Continued on page 238)

Just Out . . .
Keith Henney's
Book on
Radio

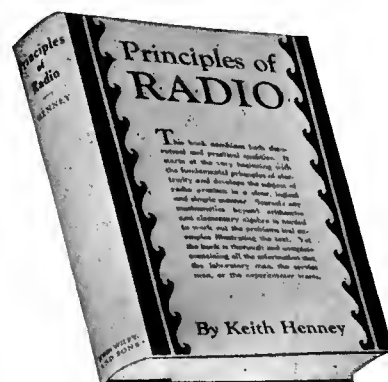

Principles
of
Radio

By **KEITH HENNEY**
Director of the Laboratory
Radio Broadcast Magazine

Readers of Radio Broadcast, long familiar with the work of Keith Henney in his capacity as Director of the Magazine's Laboratory, will be eager to secure his first book, just released from the press.

This book brings together within one cover the kind of information on radio which will appeal to the practical interest of every radio experimenter, technician, engineer, and fan. It contains the latest data and the most modern methods. It treats in a thoroughly practical way everything from the production of radio currents to their reception and transmission. Many problems, examples, illustrations, experiments, are here presented in book form for the first time.

Keith Henney, by reason of his wide experience as an operator, engineer, and writer, has the gift of making technical information readily understood by the reader.

See a Copy on Ten Days' Approval
Price \$3.50

A Wiley Book

ON APPROVAL COUPON

JOHN WILEY & SONS, INC. RB 2-30
440 Fourth Ave., New York City

Gentlemen: Kindly send me on approval Henney's "Principles of Radio." I agree to remit the price (\$3.50) within ten days after its receipt or return the book postpaid.

Name

Address

Reference

(Continued from page 237)



PILOTRONS

These tubes, built to satisfy professional radio engineers and custom set-builders, will surely satisfy your customers. "Good Sets Deserve Pilotrons, Others Need Them"!
 Pilot Radio and Tube Corporation,
 323 Berry Street, Brooklyn, N. Y.

Favorable Business Indications

The radio dealers' survey conducted by the Department of Commerce and the NEMA indicates that average sales of radio equipment for the third quarter of 1929, as reported by 6237 dealers out of a total of 38,000, showed an increase of 14 per cent. over the same period in 1928. The average value of the sets sold showed a decline of from \$167 to \$155 as compared with the same period in 1928. Average sales per dealer compared as follows: 1928, \$3030; 1929, \$3450. An increase in fall stocks is shown by the rise in average inventory for dealers from 9 a.c. sets on July 1, 1929, to 14 on October 1 of the same year.

TRIAD: Increased business and enlarged volume of orders now on hand is the report of H. H. Steinle, sales manager of Triad, in December. More than two hundred jobbers and factory distributors are now on the company's books.

R. M. A.: "While 1930 may not exceed the record-breaking sales volume of 1929," says Herbert H. Frost, chairman RMA Merchandising Committee, "there is every reason to believe that there will be fewer manufacturers and fewer dealers, which is a guarantee that those who remain and do a sound and sane merchandising job will profit to a greater extent than has been possible in the past. No matter what may evolve from the present manufacturing situation, the public will continue to buy radio receiving sets and the retail trade to sell them."

ATWATER KENT: In the early part of December, Mr. Kent wired his distributors: "We will continue to manufacture and sell the present Atwater Kent line throughout the spring season."

Financial Notes

GRIGSBY-GRUNOW: Earnings for the six months ending November 30, 1929, were above dividend requirements at the rate of \$2.00 a share for the full year. The Regular quarterly dividend of 50 cents a share on the common stock was declared. The company has acquired the plants of the General Motors Corporation, which it formerly occupied under lease. On December 6 president Grigsby said, "Sales to consumers are running double the present rate of production, which will permit distributors and dealers to clear their inventories of merchandise by the first of the year."

WESTINGHOUSE: On December 11th this company raised its dividend rate on common and preferred stock to the rate of 10 per cent. per annum, declaring a quarterly dividend of \$1.25.

TEMPLE: Payment of the regular quarterly dividend (45 cents) on convertible preferred stock was passed December, 1929.

RADIO PRODUCTS CORPORATION: Ten months ending October 31, 1929, net earnings \$540,370. This is equivalent to \$5.40 a share on 100,000 outstanding shares. Net earnings for this period, \$195,472.

POLYMET: January 2d this company declared its regular quarterly dividend in cash and stock at the rate of \$1 and 4 per cent. in stock. Total net sales August 1 to November 30, 1929, \$2,002,359. Total fiscal year net sales estimated at \$4,000,000.

POSTAL TELEGRAPH: Postal Telegraph Cable and Radio operating revenues nine months ending September 30, 1929, \$29,558,577.10.

News of the N. F. R. A.

The Cleveland Convention of the N.F.R.A. is occupying the center of the stage and at the February meeting reports of committees on accessories, better selling, market study, and trade relations, will be made. Reports will also be given by the Tube Committee, headed by J. M. Blackman of New York, the Set Committee, headed by Harry Alter of Chicago, and the Traffic Committee headed by Francis E. Stern, Hartford.

The Stanton Motor Company, of Columbus, Ohio, and the MacGregor Radio Corporation, New Haven, Conn., are new members of the Radio Wholesalers Association.

The Radio Guild of Cincinnati has recently joined the N.F.R.A. Within the last nine months, nearly forty new local associations have been established in various points throughout the country.

The N.F.R.A. has reprinted its booklet, *How to Organize a Local Radio Trade Association*. Copies can be secured from H. G. Erstron, National Federation of Radio Associations, 32 West Randolph Street, Chicago, Ill.

Television Schedule

Two stations of the Jenkins Television Corporation are now in operation. They are w2xcd, Passaic, N. J., 500 watts, 1604 kc. (187 meters), and w2xcr, Jersey City, N. J., 1000 watts, 2150 kc. (140 meters). The hours of operation are:

w2xcd 8 to 10 P. M. daily except Sunday (E. S. T.)

w2xcr 8 to 10 P. M. daily except Sunday. (E. S. T.)

At present the Passaic station is sending out the sound accompaniment for the shadowgraphs transmitted on the 140-meter wavelength by the Jersey City Station.

RCA Tube Licensees

At the close of the year eleven independent tube manufacturers had been licensed by the Radio Corporation of America for the manufacture of vacuum tubes for radio receiving sets. The first company to accept a license was the Raytheon Manufacturing Company in March, 1929. The complete list of companies and their presidents follows:

- Allan Mfg. and Electrical Corp., Clark Bldg., Central Ave., Harrison, N. J. Henri Sadacca, president
- Ceco Manufacturing Company, Inc., Providence, R. I. Ernest Kauer, president
- Champion Radio Works, Inc., Danvers, Mass. F. W. Marsh, president
- Hygrade Lamp Company, Salem, Mass. E. J. Poor, president
- The Ken-Rad Corporation, Owensboro, Ky. Roy Burlew, vice president
- Matchless Electric Company, 1500 N. Ogden Ave., Chicago, Ill. Paul C. Dittman, president
- National Union Radio Corporation, 400 Madison Ave., New York, N. Y. Nathan Chirelstein, president
- Nilco Lamp Works, Inc., Emporium, Penn. Ben Erskine, president
- Raytheon Manufacturing Company, Kendall Square Bldg., Cambridge, Mass. L. K. Marshall, president
- Tung-Sol Radio Tubes, Inc., 95 Eighth Avenue, Newark, N. J. H. W. Harper, president
- United Radio & Electric Corporation, Irvington, N. J. J. G. Weiss, president

AMERICAN BOSCH IN ITALY: Fabrica Italiana Magneti Marelli, Milan, Italy, has contracted with American Bosch for manufacture and sale of radio sets and radio products in Italy and other European countries for a period of five years. The agreement provides also for interchange of designs, inventions, manufacturing processes, and advertising, selling and servicing.



By the author of

"Principles of Radio Communication"

An independently written introduction to the subject of Radio

John H. Morecroft

Elements of Radio Communication

BY JOHN H. MORECROFT

"We can highly recommend 'Elements of Radio Communication' to those of our readers who want a book that will give them a strong, elementary grounding in radio and leave them with few questions to ask save those which may be born of a desire for more knowledge."

Boston Post Radio Section

\$3.00

JOHN WILEY & SONS, Inc.

440 Fourth Ave., New York

Please send me Morecroft's "Elements" for free examination. Within ten days after its receipt I will either return the book or send you \$3.00.

Name.....

Address.....

Firm.....RB 2-30

SHALL WE BUY OR MAKE PARTS?

By **DAWSON J. BURNS**

Vice-President and General Manager, Ward Leonard Electric Company

IN ANY manufacturing business involving the assembly of a number of component parts, the question frequently arises as to the economy of manufacturing these components, rather than buying outside. Naturally, an alert production department is anxious to add new processes which will level off production peaks, and the cost department feels certain that the labor and material costs will be kept well below the best outside supplier's quotation.

A careful analysis shows three major premises in favor of internal manufacturing, rather than outside buying: first, better utilization of employed labor; second, lower final costs; third, closer contact with, and consequently better control of production. The idea of improving the quality of a part through internal manufacturing, rather than outside purchases, seldom enters into question. The parts manufacturer is generally recognized as best able to turn out his specialized product. A manufacturer who contemplates making a part inside his own plant, almost invariably has the idea of turning out a part which will do the job satisfactorily, even though it may not be equal to a job of an outside manufacturer.

As a general premise I shall say that a manufacturer can buy parts more cheaply than he can make them. However, this must be qualified by saying that it is broadly true only if the process of making that part is fairly difficult and if technical skill and background enter into its design and manufacture. Take, for example, the case of a resistor manufacturer with which, naturally, I am most familiar. The manufacture of high-grade resistors, while it may appear a rather easy task, really involves extensive engineering background, not to mention any number of production problems, which at first glance are not apparent. From the standpoint of cost, we feel that no one can manufacture, as a component part, resistors of the high quality demanded in radio work, and produce them at a lower price than we do, without losing money in the end.

A brief analysis serves adequately to illustrate the point. To set up for internal production of an item, let's say resistors, a manufacturer must automatically increase the personnel or place a burden on many departments. The purchasing department must gather materials and return defective parts; the technical staff must closely supervise and test the quality of incoming materials, and the engineering department must design the desired product and follow it through production. All departments concerned must handle and be responsible, not for one item, but for a multiplicity of items. The executive management of the company must correlate the work of the several departments. Personnel must be greatly increased or there is bound to be a costly and even a disastrous slip somewhere along the line, which will delay the final production of the completed unit.

If a radio company adds executives to cover each minor manufacturing process it finds itself involved in a mass of production details far removed from its primary function of turning out and selling radio receivers. Where the manufacture of new items is undertaken inside the plant, the risk to the merchandising success of the completed receiver becomes greater. Things which looked easy turn out to be difficult and there is apt to be one costly delay after another.

Let us take the case of Ward Leonard

The development of the radio industry has seen a gradual trend towards the manufacture rather than the purchase of many of the component parts necessary in the production of radio receivers. However, the economics of this problem are not entirely settled, and it is for this reason that we present the following comments by Mr. Burns on some of the factors that must be considered.

The question, we realize, is a controversial one. It can only be answered by a careful and complete study of all the factors that are involved and we expect in a future issue to present more complete data on the subject. Meanwhile the Editors would be glad to have the opinions of engineers and other executives who have given the matter some consideration.

—THE EDITOR.

as an example. Our company consists of specialists in resistors. We have and maintain executive, engineering, and research staffs. At present there are some 75 electrical engineers devoting their entire time to designing, improving, and supervising the manufacture of resistor units. We would no more presume that these men could turn out a really well-engineered radio set, than we would expect a radio manufacturer to turn out really well-engineered resistor units.

THE HI-Q 30 KIT

(Continued from page 211)

describing in detail the design of the Hi-Q 30 and it is suggested that interested experimenters send for this booklet. It can be obtained for 25 cents directly from Hammarlund-Roberts, Inc., 424-438 West 33rd Street, New York City.

Cost of Kit

The following is a list of the Hi-Q 30 models, numbers, and prices:

Kit	Code	Price
A. C.	30-R-A.C.	\$162.50
Battery	30-R-Bat	119.15
A. C. Tuner	30-T-A.C.	138.65
Battery Tuner	30-T-Bat	93.80

A list of the cabinets available for the Hi-Q 30 receiver is as follows:

Name of Cabinet	Price
Milan	\$600.00
Arden	96.50
Raleigh	75.00
Stratford	55.00
Cambridge	96.00
Yorkshire	75.00
Oxford (Table)	28.50
Windsor (Phono-Radio)	175.00
Blackstone	150.00

ANSWERS TO PROBLEMS

Answers to problems given in "Engineering Review Sheet" No. 29 (page 215) are as follows:

- (1) Approximately 7.
- (2) 1.35 megohms.
- (3) 15 milliamperes; 5 milliamperes.
- (4) From -9 to -159 volts; 53 milliamperes; 190 volts.

ELECTRAD PERFORMANCE

Your Protection Against High SERVICE COSTS

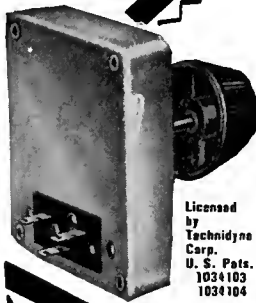

Licensed by Technidyne Corp. U. S. Pat. 1034103 and 1034104

ELECTRAD Super-TONATROL

A volume control designed especially for use with the high voltages of modern receivers. Made on a new and superior principle. The resistance element is permanently fused to the surface of an enameled metal plate. A pure silver contact gives marvelously smooth action. 7 types for all usual uses. List Price, \$2.40 to \$3.50.

You can recommend **ELECTRAD** Resistances and Voltage Controls for every radio purpose—because they are built to **PERFORM**. Highest Quality—prices made possible by **ELECTRAD'S** tremendous production—**are your** guarantee of satisfaction—**from your** parts department, and lower service costs. **Mail the Coupon today for information about the complete ELECTRAD Line.**

U. S. Pat. 1078869 and Pat. Pend.

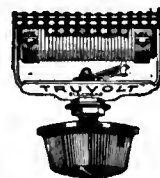

TRUVOLT The Safe Resistance for Eliminators

Heavier-than-usual Nichrome resistance wire. Air-cooled—perfectly insulated—accurate values—longer life. Variable models (illustrated) simplify eliminator construction. 22 sizes, list, \$2.50. Fixed models have exclusive sliding clip for exact setting. All usual sizes.

ELECTRAD, Inc., Dept. RB-2
175 Varick Street, New York, N. Y.
Please send data on following products:
 Super-TONATROL TRUVOLT Resistances All Products.
Name _____
Address _____

175 Varick St., New York, N. Y.

ELECTRAD INC.

IN THE RADIO MARKETPLACE

News, Useful Data, and Information on the Offerings of the Manufacturer

Gulbransen Model 291

GULBRANSEN COMPANY: The Gulbransen Model 291 embodies the same principles of construction and mechanical features as the

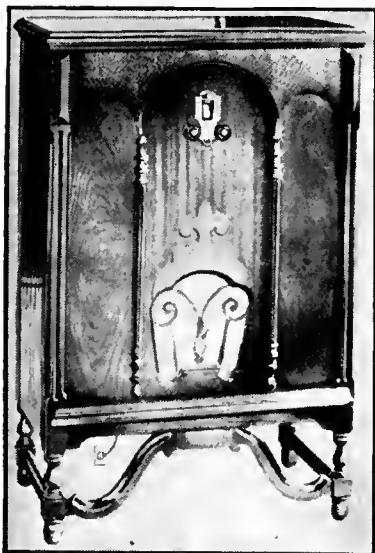

Model 292. Screen-grid tubes, 245 power tubes, accurately matched condensers and filters, local- and long-distance switch, and a phonograph-radio switch operated by the knob that controls the a. c. switch, (patent applied for) are distinctive features of this new radio model. Price: \$139.50.

Eveready Series 30

NATIONAL CARBON COMPANY, INC.: Features of the series 30 Eveready receivers are: sturdy, rigid mechanical design and permanent all-metal construction of the chassis foundation; variometer associated with the gang condensers; rugged three-gang condenser; dual loud speaker provision, giving the customer his choice of electrodynamic or magnetic operation (Table Model, only); simplified, trouble-free condenser drive, with automatic slack take-up, rugged, "flapper-type" condenser antenna trimmer; grid-bias method of volume control.

New Erla Receiver

ELECTRICAL RESEARCH LABORATORIES, INC.: The Erla receiver is a seven-tube set, one-dial control, using two 224-type screen-grid tubes, two 227's, two 245's, the latter being push pull, and one 280 rectifier tube. Tip jacks are em-

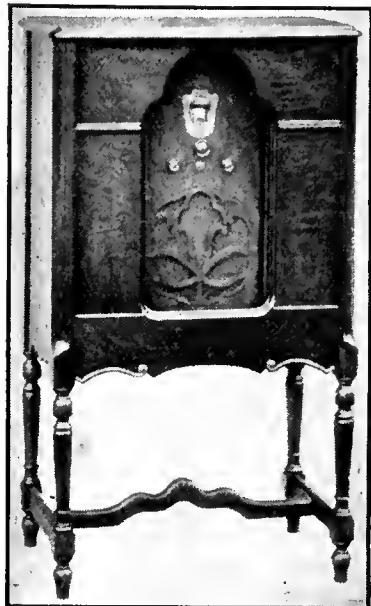

ployed in the receiver for the connection of a phonograph pick-up unit, and arrangements have been made to provide ample power to operate the pick-up properly. The long and short antenna control is located on the panel.

Radiola 47

RADIO-VICTOR CORPORATION OF AMERICA: This is a four-tube phonograph radio combination using two stages of r.f. amplification and a power detector, followed by a single 245-type tube. Screen-grid tubes are used in the two r.f. stages and a third screen-grid tube is used as the detector.

New Parts Catalog

ALDEN MANUFACTURING COMPANY: A booklet entitled "Something Lower Priced That is Actually Better" has been published by this company. It gives complete data on the various parts which this company manufactures. These parts include sockets of all types, multiple wire attachment plugs, special adapters, etc.

Bosch Model H

AMERICAN BOSCH MAGNETO CORP.: The Model H console recently added to the line of Bosch receivers has tall sliding doors with the grill for the loud speaker located above the



tuning control. Equipped with a Bosch screen-grid chassis and electrodynamic loud speaker this model lists at \$198.50.

Crosley 30-S and 40-S Sets

CROSLY RADIO CORPORATION: Among the features of the Crosley 30-S and 40-S screen-grid receivers are improved type of volume control, combined range control and switch, power detection with resistance-coupled audio-frequency amplification, push-pull output with 245 tubes. These chassis may be obtained with the front panel only for console mounting, in metal table-type cases, or in wooden console cabinets.

The Ware Model J5

WARE MANUFACTURING CO.: A new chassis, the J5, in which a screen-grid tube is used as an a.f. amplifier has been developed by this company. Other features of the receiver are Vreeland band tuning, duplex sensitivity control, phonograph switch, and complete shielding. The J-5 chassis lists at \$75.

Stewart-Warner

STEWART-WARNER CORPORATION: The latest Stewart-Warner receiver uses the company's standard eight-tube screen-grid chassis in a Tudor period console. Less tubes this model is priced at \$131.50.

Victor Model RE-75

RADIO-VICTOR CORPORATION OF AMERICA: The newest addition to the Victor line is the Model RE-75, a combination phonograph and



radio. Several leather-back record albums are provided with the instrument.

New Power Amplifiers

THE RAULAND CORPORATION: In collaboration which Jenkins and Adair, several power amplifiers have been designed especially for use in public-address systems and talking movies. Several new transformers have also been announced including a standard shielded model listing at \$1.50, a laboratory grade model listing at \$7.50, and an unshielded replacement transformer priced at \$2.25. The Rauland Corporation has purchased all the dies, tools, and other materials formerly owned by the All-American Mohawk Corporation and used in the manufacture of All-American transformers. It is understood that the latter corporation has discontinued the manufacture and sale of transformers except those used in connection with its regular line of radio receivers.

New Brunswick Models

BRUNSWICK-BALKE-COLLENDER COMPANY: The Models S-14, S-21, and S-31 are recent additions to the line of Brunswick radio receivers. The Models S-14 and S-21 are complete a.c.-operated radio receivers, the Model 14 being a lowboy listing at \$148 and the Model 21 being a highboy listing at \$174. The Model S-31 is a radio receiver in combination with a Panatropo and lists at \$272.



New Westinghouse Meters

WESTINGHOUSE ELECTRIC AND MANUFACTURING COMPANY: This company is manufacturing a new line of meters designed for production testing where high accuracy is required. The production testing of vacuum tubes, for example, is a field in which these new instruments might be used. The accuracy required in this work is generally much higher than that obtainable with ordinary panel or switchboard type instruments. For example, it is well known that a slight error in the setting of the grid voltage in the testing of radio tubes will result in a very large difference in the plate current. Switchboard instruments are not primarily intended for close measurement work and the calibration accuracy of such instruments is generally of the order of 1 to 3 per cent. allowable error. Many of the smaller types of switchboard instruments are furnished with etched printed dials resulting in variable accuracy at different scale points.

In order to provide a line of instruments especially intended for high accuracy, production testing engineers have carefully studied the problems of testing measurements and this has resulted in the design of the so-called "panel



standard instruments." These were originally intended for mass production work on vacuum tubes but are, of course, equally applicable to all kinds of manufacture where quick and highly accurate inspection readings or tests are necessary.

Briefly the "panel standard instruments" consist of the combination of a panel or switchboard type cases and mountings into which are placed high-accuracy portable instrument mechanisms. The dial marks are hand calibrated of the fine line type enabling close readings to be taken. The calibration is performed with the same painstaking care and by the same experts that perform the calibration on the high-grade portable instruments.

The illustration clearly show the scale and pointer of one of these panel standard instruments. The scales are 4" long and very clearly divided. The cases are only 4 1/4 inches in diameter and, therefore, the instruments are very compact, taking up the least possible space on the panel. A large amount of experience, particularly in actual production of radio tubes, has shown that this size of instrument is the best suited for general production testing purposes.

New Sonora Models

SONORA PHONOGRAPH COMPANY, INC.: The Sonora models, designed expressly for screen-grid operation, each have three screen-grid radio-frequency tubes, a power detector, and one stage of push-pull amplification employing two 245-type tubes. The chassis is completely shielded, including interstage condenser isolation.

The Sonora power electrodynamic loud speaker includes a special filter that eliminates a. c. hum. All Sonora cabinets were designed and are being manufactured entirely by Sonora, as is every other part of the new Sonora radio. The Sonora line also includes three radios of full unitized construction—tuner and detector, a. f. amplifier, power rectifier and electrodynamic loud speaker, each in separate units. There are



two types of chassis—the Studio and De Luxe. The former employs nine tubes and the latter eleven tubes. In addition, the Sonora line includes two Sonora Melodion combinations for radio and electrical record playing. One of the Melodions is equipped with the Studio chassis, the other with the De Luxe chassis. All of these models are equipped with auxiliary antenna, which may be used in place of the conventional outside antenna.

Super Synchrophase SK-4

A. H. GREBE AND COMPANY, INC.: The Super-Synchrophase SK-4 receiver is designed to operate on a 110-volt, 50-60-cycle, alternating-current supply. Special power units are available for use on lines of like voltage but 25-33-cycle frequency. The instrument consists of two major units or chassis. The r. f. amplifier chassis illustrated is the unit to which the operating controls are attached and the a. f. power-amplifier chassis is the one to which is

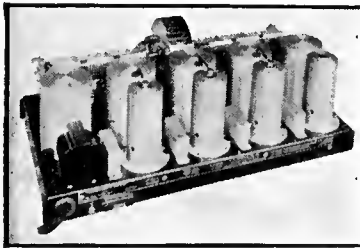

mounted the different type consoles. The circuit employs three tuned radio-frequency stages, a power detector, a single push-pull output stage, and a full-wave rectifier. The design of the receiver and circuit employed is entirely new.

New Brandes Receivers

KOLSTER RADIO CORPORATION (BRANDES DIVISION): The chassis used in the low-priced Brandes receivers manufactured by Kolster consists of a three-stage r.f. amplifier using 227-type tubes, a 227-type detector, and a two-stage a.f. amplifier with 245's in pushpull in the output. B power is obtained from a 280-type full-wave rectifier.

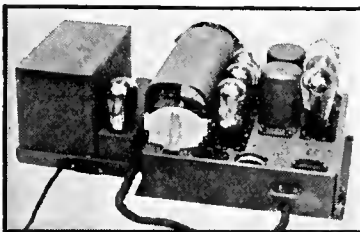

Phonograph Motors

STEVENS MANUFACTURING CORP.: The electric motors used in the small battery-operated portable phonographs manufactured by this company are of the single impulse unipolar type, completely housed in die-cast aluminum. An especially designed governor is contained within the housing. The shaft runs on ball bearings and is connected by means of a rubber pulley to the rim of the turntable, being held under constant tension against the inside edge of the turntable. The motor requires 0.2 amperes from three 1 1/2-volt dry-cell batteries. Under ordinary use the cells are good for the playing of more than 1000 records. In the portable phonographs designed for 110-volt a.c. operation a step-down transformer and a Kuprox rectifier are used to supply the necessary d.c.

Radio Equipped Dodge

DODGE BROTHERS CORPORATION: The Dodge Brothers Senior Six automobile is equipped with a radio receiver built into the dashboard. The antenna is concealed in the roof of the car



and a small loud speaker is installed just above the windshield. The two tuning dials are located on the dash within easy reach of the driver.

Polymet Parts

POLYMET MANUFACTURING CORPORATION: This company manufactures a complete line of all types of fixed condensers and fixed and variable resistors. A new catalogue illustrating these parts has just been issued. Another pamphlet has also been issued showing the use of Polymet parts in various well-known circuits.

Airplane Apparatus

PAN-AMERICAN AIRWAYS, INC.: For exclusive use on all of their multimotored airplanes the radio engineers of this company have developed a compact two-way radio system. The receiver and transmitter used on the planes have a total weight of 42 pounds. The apparatus has been designed primarily for CW transmission and reception, although the sets can be adapted for phone work. All important adjustments on both the transmitter and receiver are, of course, made before the plane leaves the ground. The apparatus is supplied from a dynamotor which is operated from the regular 12-volt storage battery. A 5-ampere, 15-volt, wind-driven generator functions to charge the storage battery during flight. In cases of forced landing the apparatus can be kept in operation for about 8 hours of continuous use. For 32- or 54-meter work an antenna running from the wing tip to the fuselage is used. For work on longer wavelengths use is made of the trailing antenna. The transmitter employs a master oscillator and power amplifier using 210-type tubes. The receiver uses a 222-type screen-grid tube with aperiodic coupling to the antenna followed by a 112A regenerative detector and a two-stage a.f. amplifier consisting of one 222 and one 112A tube. The apparatus has proven satisfactory for communication up to a distance of 1400 miles.

THE RADIO DEALER'S DIRECTORY OF RECENT PRICE CHANGES

Company	Model No.	Former Price	New Price	Reduction	Company	Model No.	Former Price	New Price	Reduction
Bremer-Tully Mfg. Co.	81	\$164.00	\$134.00	\$30.00	Graybar Electric Co.	68	\$169.50	\$129.50	\$40.00
	82	195.00	165.00	30.00		69	225.00	195.00	30.00
	S-81	164.00	134.00	30.00		72	175.00	135.00	40.00
	S-82	195.00	165.00	30.00		73	65.00	60.00	5.00
Brunswick-Balke-Collender Co.	S-14	148.00	129.00	19.00		74	119.50	109.50	10.00
	S-21	174.00	154.00	20.00		93	189.50	159.50	30.00
	S-31	272.00	249.00	23.00		94	240.00	210.00	30.00
The Crosley Radio Corp.	61-S	85.00	74.85	10.15		500	110.00	75.00	35.00
	62-S	140.00	135.00	5.00		550	179.00	130.00	49.00
	63-S	130.00	121.00	9.00		330	130.00	98.00	32.00
Earl Radio Corp.	31	139.00	116.00	23.00	520-L		133.00		
	32	169.00	142.00	27.00	523	250.00	175.00	75.00	
	41	225.00	162.50	62.50	524	295.00	225.00	70.00	
General Motors Radio Corp.	66	115.00	85.00	30.00	526	260.00	185.00	75.00	
					527	305.00	235.00	70.00	



Stop A.C. Noise!
Improve Selectivity!

PLUG in a Falck Claroceptor between wall socket and radio set and eliminate "static" from motors, street cars, telephones and electrical appliances. This new improvement by a pioneer radio parts manufacturer grounds and thus blocks out line interference noise and radio frequency disturbances. Also improves selectivity and distance. Requires no changes in set. Measures just 3½ x 5½ x 2½ inches. Thousands now all over America use the Claroceptor for clearer A. C. reception. Get one right away—at radio parts dealers. Write for descriptive folder.

Falck CLAROCEPTOR
 Built by ADVANCE ELECTRIC CO.
 260 W. Second St. Los Angeles, Calif.
 OBBERs and DEALERS, GET OUR PROPOSITION

\$7.50 complete with cord and plug

Give Your Radio Set a Chance
 Install De Forest Audions in your radio set and you will note the difference right from the start—purer tones, more volume and hum-free reproduction.

DE FOREST RADIO CO.
 PASSAIC NEW JERSEY

de Forest AUDIONS

No. 319

RADIO BROADCAST Laboratory Information Sheet

February, 1930

Apparent Demodulation of Weak Signals

IN NOVEMBER, 1929, *Experimental Wireless and the Wireless Engineer* S. Butterworth published a short article entitled "Notes on the Apparent Demodulation of a Weak Station by a Stronger One." In this article the author treated mathematically the effects which occur when two modulated carriers are applied to a linear detector of perfect characteristics, i.e., the detector that completely suppresses one half of the applied signal.

With such a detector it is found that the intensity of the two audio-frequency signals produced by demodulation do not bear the same ratio as do the carriers of the applied signals. Instead it is found that the ratio of the audio-frequency outputs is greater than the ratio of the carriers, the differences in these two ratios becoming greater with increases in the ratio of the two carriers. The only point at which the carrier ratio and the audio-frequency ratio are equal is where the two carriers have the same value. When the two carriers have a ratio of 10 to 1 the audio-frequency signals produced by the demodulation of the carriers have a ratio of 200 to 1. In other words, if two modulated carriers have a ratio

of 10 to 1 and the stronger carrier produces an audio-frequency output of 1 volt then the output due to the weak carrier is only 0.005 volt. The net result of this apparent demodulation of a weak signal by a strong signal is that the apparent selectivity, as judged by the ratio of the two audio-frequency outputs, is greatly increased.

The figures given in Mr. Butterworth's article have been plotted in the form of a curve which appears on Laboratory Sheet No. 320. From this curve it is possible to determine quickly the audio-frequency ratio for carrier ratios of from unity to 10.

The audio-frequency ratios indicated on the curve are, of course, only obtained when the detector is perfect, and, as the detector departs from this characteristic, the apparent demodulating effect decreases.

This same effect treated mathematically by Mr. Butterworth was illustrated graphically and experimentally by F. E. Terman in his article entitled "Linear Power Detection" published on page 49 of November, 1929, *RADIO BROADCAST*.

No. 320

RADIO BROADCAST Laboratory Information Sheet

February, 1930

Apparent Demodulation of a Weak Signal

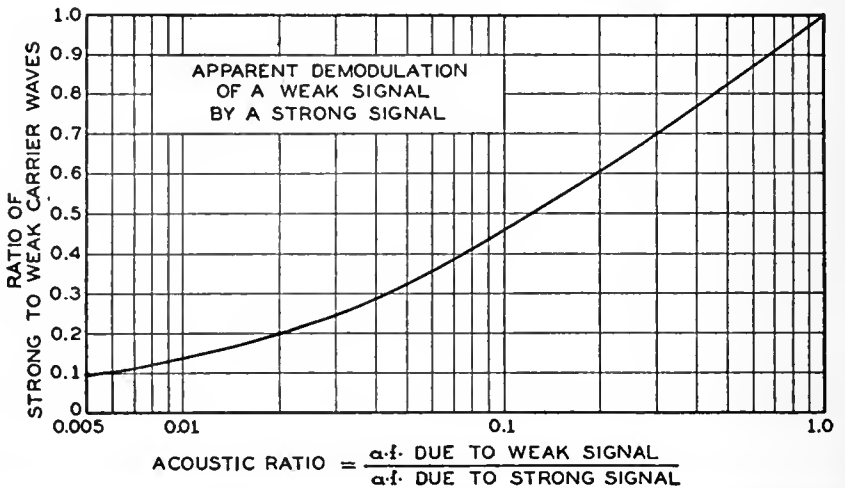

No. 321

RADIO BROADCAST Laboratory Information Sheet

February, 1930

Service Procedure

IN THE servicing of radio receivers a sensible, systematic method of testing is most essential. Testing this, that, and the other thing—testing haphazardly, in other words—will finally lead one to the fault, but it can hardly be called the proper method of procedure. In servicing, as in most everything, there is a proper place to start and a proper procedure that will locate most quickly the thing we are looking for.

Voltages delivered to the tubes should first be checked. This should usually be done.

If there is some definite indication of the trouble it is usually a simple matter to fix it, but if there are no indications of what part of the circuit is at fault, it is generally best to proceed somewhat as follows:

First check the a.f. amplifier. Lightly tap the detector tube and listen for a response from the loud speaker. If the set has a phonograph connection (and most receivers have) connect a pair of headphones to the circuit, tap the diaphragm of the phones and listen for an answering tap from the loud speaker. If there is no response from the loud speaker, the fault must be in the a.f. amplifier, the power tubes, the loud speaker, or the voltage supply to these tubes.

The next part of the circuit to test is the detector. It is usually possible to disconnect the antenna from its usual location and connect it instead directly to the stator plates of the variable condenser tuning the detector circuit. By tuning the set it should then be possible to pick up powerful local stations providing the detector circuit is functioning properly. If the a.f. amplifier works satisfactorily but no signals can be picked up with the antenna connected as indicated above, there is probably some fault in the detector circuit.

After checking over the a.f. amplifier and detector circuits, it is then possible to check the r.f. amplifier, the simplest method being to touch the antenna to the plate terminal of the r.f. amplifier tube preceding the detector, then to the plate circuit of the preceding r.f. amplifier, etc., until the normal antenna connection is reached.

By systematically testing in this manner it is generally possible to locate quickly the point in the circuit where the fault lies and then to take whatever measures are necessary to correct it. The need of a good set tester in such work is, of course, obvious, for without one it is hardly possible to determine accurately the condition of the tubes and whether or not they are receiving proper voltages.

A PRODUCTION TESTING SYSTEM

(Continued from page 205)

batteries. We have found that a.c. B-supply systems fluctuate too much to insure consistent readings.

Iron-Core Choke Coils

The testing of filter choke coils, while important, is not difficult and we have found that these coils invariably function satisfactorily when passed by our final test fixture. In our receivers two chokes are used, one having an inductance of approximately 7 henries with 70 mA. d.c. flowing through it and the other 70 henries with 15 mA. Both of these coils have a cardboard gap which, in production, is sometimes omitted, so it is imperative that they be tested with their normal d.c. component.

The coils upon receipt by the inspection department are first tested for shorted turns by the shorted-turn tester previously described. The coils and cores are then assembled and tested for inductance and resistance by the test fixture shown in a picture and the schematic circuit (Fig. 3).

The fixture consists of a simple inductance bridge having two standard legs either of which may be inserted by a selector switch. The resistance or limit legs consist of a 400-ohm potentiometer to which a dial is attached with limits painted on it. Balance or minimum signal is recorded by a V.T.V.M. The single-stage amplifier is used to give greater deflection of the V.T.V.M. The d.c. component is kept out of the coupling coil by a blocking condenser and adjustment of it is made with a 200-ohm rheostat. The sensitivity of the V.T.V.M. is controlled by a 200-ohm potentiometer connected across the A battery with the lever to the potential. Possible continuity between the coil and core is tested for by throwing a switch from the test to the break-down position, the latter applying a potential of 220 volts a.c. between the core and coil. Continuity is indicated by a W.E. 41Y ringer. This fixture uses one A battery and one 45-volt B battery, the latter serving as plate supply for the amplifier and the source of d.c. for core saturation.

[Editor's Note: Mr. Callanan's third article will discuss the testing of radio-frequency coils, radio-frequency chokes, loud speaker coils, and resistors.]

MERGERS IN THE RADIO INDUSTRY

(Continued from page 195)

its manufacturing facilities to the excellent plant of the former at South Haven, Michigan. The American Piano Company is purchasing chassis of the band-pass type by contract with the Ware Manufacturing Corporation, a revival of the once-predominant Ware Radio Company. Other mergers of this character represent the same objective, the maintenance of a musical industry which could not survive without radio and the strengthening of a radio company by association with the capital, experience, manufacturing facilities, and distribution channels of an existing music company.

The Third Group

The third grouping of mergers, mergers for expansion, promises soon to become the most significant and active in the radio field. Up to now, such mergers have been principally the union of a strong unit with one or more decidedly weaker ones. An outstanding exception to this rule is the merger of Newcomb-Hawley with Peerless to form the United Reproducer Company. Both were strong companies at the time of merger, leading manufacturers of repro-

(Continued on page 244)

Wright-De Coster Reproducers

The Perfection of
Theatrical Reproduction
— For the Home —



Model 117 Jr. Consollette

Beauty and clearness of tone. Fidelity of reproduction.

The same wonderful reproduction as our nationally famous theatrical reproducers with volume diminished for homes or small halls.

Beautiful Cabinets

This model may be used for a table or, with handsome spinnet legs added, makes a most attractive console.

Get Full Details

Write for complete information.



"The Speaker of the Year"



Model 117 Jr. Table Style

WRIGHT-DE COSTER 2213 University Ave., St. Paul, Minn.

Export Office: M. Simons & Son Co., 220 Broadway, New York City

Cable Address: Simontrice, New York

Smooth Flowing—

POWER!

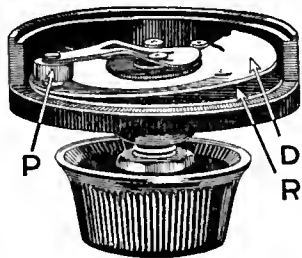

THIS shows the exclusive rocking disc construction of Centraiah volume control. "R" is the resistance. Contact disc "D" has only a rocking action on the resistance. Pressure arm "P" together with shaft and hushing is fully insulated.

Like a deep smoothly flowing stream the volume control on your radio, if it is a CENTRALAB, delivers a constant, uninterrupted flow of power that results in the purest, finest tone.

The most famous American radios are CENTRALAB equipped. Is yours?

Write Dept. 218-E
for Free Booklet
"Volume Controls,
Voltage Controls,
and Their Uses."

Centralab

CENTRAL RADIO LABORATORIES

Dept. 218-E, Keefe Ave., Milwaukee, Wis.

Inductance of Coils

LABORATORY SHEET" No. 323 contains a set of curves by means of which the inductance of a coil in microhenries may be determined if the size of the tube, size of the wire, and number of turns are known; or conversely, a coil of any given inductance may be constructed using the number of turns indicated by the chart for the particular size of tube and size of wire to be used. The chart covers tube sizes of three and four inches and wire sizes of No. 16, 18, 20, 22, and 24. In all cases the wire is double cotton covered.

The curves are based on the simplified formula for the inductance of a coil—

$$L = \frac{n^2 n^2 K}{10 v}$$

where L = inductance in microhenries
 a = tube radius in inches
 v = length of winding in inches
 n = number of turns of wire
 K = a constant

Using the chart on "Laboratory Sheet" No. 323

in conjunction with the chart given on "Laboratory Sheet" No. 286, it is possible to determine quickly how many turns of a particular size of wire are necessary on a given tube to cover the broadcast band with a certain size variable condenser.

For example, suppose a coil were made for use with a 0.0005-mfd. variable condenser. The chart on Sheet No. 286 indicates that 170 microhenries of inductance are required, to tune up to about 550 kc. Suppose we wanted to use a 3-inch tube wound with No. 22 wire. By referring to the chart on the following sheet we find that in order to obtain an inductance of 170 microhenries the coil must have 47 turns of wire.

With these two charts it is also possible to work back and find the size condenser necessary to tune a given coil over the broadcast band. Suppose we had a coil wound with 65 turns of No. 24 wire, the tube size being 3 inches. What size variable condenser will tune it over the band? By referring to the chart below we find that such a coil will have an inductance of 295 microhenries. Then, referring to the chart on Sheet No. 286, we can determine that a 0.0003-mfd condenser will be required.

Inductance of Coils

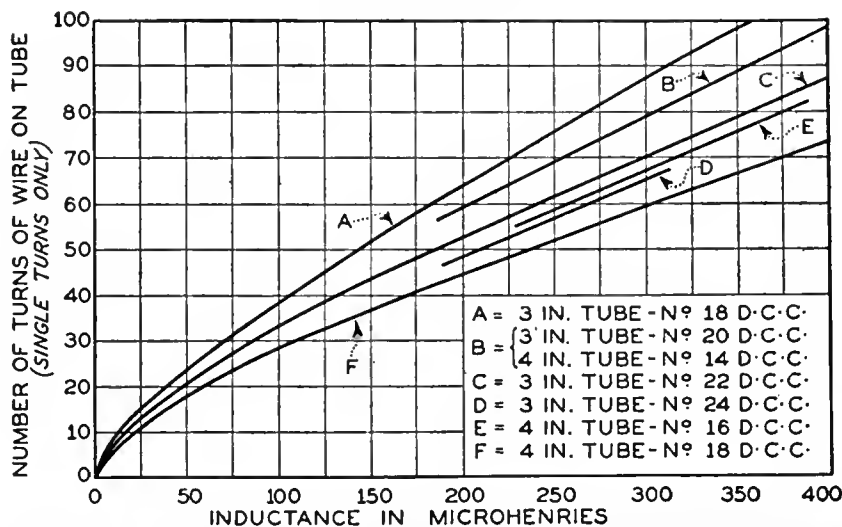

Hum vs Volume Control

THERE IS A characteristic difference in the operation of receivers with and without automatic volume control circuits which has a fundamental effect on the amount of a.c. hum from the loud speaker.

In a receiver in which the volume control is located in the r.f. amplifier the detector must function at a level depending upon the setting of the volume control. At high volume levels the detector must work at r.f. input voltages large in comparison with those applied to the detector when the desired volume level is low. Now, in a set using an automatic volume control, the manual volume control is usually located in the a.f. amplifier and the automatic circuits function to apply a constant r.f. voltage to the detector. As a result the a.f. output from the detector is constant and volume is adjusted by impressing more or less of this constant detector output on the following a.f. amplifier tube. The fundamental difference between these two arrangements is, therefore, that in one case the detector input varies and in the other case it is constant.

The hum from the detector circuit is responsible for a large part of the hum finally impressed across the loud speaker. The hum voltage from the detector is constant—it does not depend on the setting of

the volume control. Therefore, if the desired signal is much louder than the hum at all volume levels it is necessary to operate the detector at signal levels such that the desired a.f. output is always much greater than the hum output. With the volume control in the r.f. amplifier this is not always possible, for, when the volume is turned down very low, the desired signal output may become comparable with the hum output of the detector. If, however, the volume control is in the a.f. amplifier the detector is operated at high signal levels at all times regardless of the setting of the volume control. As a result, in receivers with automatic volume the ratio of desired signal to hum in the plate circuit of the detector tube is always high, and, other factors being equal, the hum from receivers using automatic volume control will be less than that from receivers not using automatic volume control, provided the manual volume control is in the a.f. amplifier.

It is, of course, at low volume levels that the difference in hum will be most noticeable, for it is at such levels that the hum voltage from the detector will be largest in comparison with the desired signals. At high volume levels there is no reason why the hum from sets without automatic volume control should not be equal to that from sets with automatic volume control.

(Continued from page 243)

ducers. The new company is exploiting the Kyle condenser loud speaker and has embarked upon the manufacture of receivers employing the new reproducer. To enter the receiver field, the reproducer company acquired the Arborphone Company, an R.C.A. licensee. Whether the outcome of this fundamental change of policy means the abandonment of leadership in the reproducer field in order to concentrate on the receiver business is not yet determined.

Another merger which held hope of becoming of major significance was that of the Charles Freshman Company with the Freed-Eisemann Radio Corporation. Both of these companies were operating in rented manufacturing plants, unsuited to expansion. As a result of the merger, they acquired a new plant in which both brands of receivers are made, exchanged directors, but otherwise maintained their separate identities through competitive advertising and merchandising. The Charles Freshman Company recently changed its name to Earl Radio Company; Freed Eisemann is Freed Radio Corporation. Both are pioneer radio companies which have been, at different times, among the topnotch producers. The effect of combination has not yet manifested itself as advantageous; both companies are in the hands of a receiver.

Tube Makers Merge

A merger of several successful tube companies, some of them rather small units, resulted in the formation of the National Union Radio Corporation, a combination of Sonatron, Televocal, Marathon, and Magnatron tubes. It is not yet determined whether this merger is merely a pooling of the capital stock of the various companies which are to operate as individual units through a combined merchandising department, or whether the brand names will be submerged under a new brand name. It requires an outstanding merchandising success to establish the importance of this merger, but potentially this is a major independent tube company.

Another smaller merger in the same field is that represented by the present Marvin Tube Company. The essential units of the present company were six scattered and small companies, now unified, but already under partial control of the Studebaker interests, of South Bend, who are the leading financial factors in

Colin B. Kennedy. One of the most notable events in the tube field is the association of the Raytheon Manufacturing Company with National Carbon, the latter having an exclusive merchandizing contract and general supervision over the operations of the former.

A different character of merger is represented by the combination of interests of Utah, Eby, Carter, and Caswell Runyon, each suppliers of different elements of radio receivers to set manufacturers, Utah being an outstanding reproducer manufacturer; Eby, binding posts; Carter, small parts; and Caswell Runyon, cabinets. Substantial sales economies are promised as a result of this merger because each of these companies has heretofore maintained a separate sales force, each catering to the same trade. The merging of Easton Coil Company with Polymet can also be included in the miscellaneous classification.

The acquisition of the American Radio & Research Corporation, makers of Amrad sets, by the Crosley Radio Corporation is merely an acquisition of stock ownership. Both companies are operating separately without coordination of their respective sales departments or distribution systems.

One retail distribution merger indicates a trend which may gain headway on a very extended scale in the immediate future. This is the merger of Davega, Abe Cohen, Exchange, City Radio Stores, Atlas Stores

Corporation, and Fanmill, making a total of 61 retail outlets distributing in the principal radio centers of the East and Central West. With the prospective competition of well-established automotive retail distribution systems, widespread merger of the small independent radio retailer in equally well-organized chains is not an unlikely prospect.

The characters of mergers in the radio industry, up to this time, have, with but a few exceptions noted above, been more or less of a distress nature and do not represent greater efficiency in distribution or the combination or elimination by absorption of important companies. The time is now ripe for merger conversations and the writer has noted, in his contacts about the industry, that this thought is becoming uppermost in the minds of many radio executives.

THE R.C.A. THEREMIN

(Continued from page 202)

volume is secured when the UX-120 emission is zero, or nearly so.

Thus, a movement of one hand in relation to the pitch-control rod will cause a variation in pitch and allow the playing of music. A movement of the other hand in relation to the volume-control loop will cause an increase or decrease in volume. The combination of these two movements constitutes the technique of playing the RCA Theremin.

The tables below give the electrical and physical characteristics of the Theremin.

ELECTRICAL SPECIFICATION

Voltage Rating.....105-125 Volts
 Frequency Rating.....50-60 Cycles
 Power Consumption.....90 Watts
 Type of Circuit.....Special heat-frequency oscillator with a.f. stages
 Number and Types of Tubes
 Three UX-227, 1 UX-224, 1 UX-120,
 2 UX-171A and 1 UX-280—Total 8
 Number of Oscillators.....3
 Type of Detector

Two-grid detector modulator
 Number of A. F. Stages.....2
 Recommend Loudspeaker
 RCA Loudspeaker 106
 Musical Range—3½ Octaves
 Lowest note of loudspeaker
 to 1400 cycles approximately

PHYSICAL SPECIFICATIONS

Height to top of Pitch-Control Rod 64 in.
 Height of Cabinet.....46½ in.
 Width, including Volume-Control Loop
 31½ in.
 Width of Cabinet.....19 in.
 Depth.....12 in.
 Dimensions of Packing Case
 14½ in. x 24 in. x 51 in.
 Weight, Net.....67½ lbs.
 Weight, Shipping.....99 lbs.

THE SUPREME DIAGNOMETER

(Continued from page 218)

open, shorted, or leaky by-pass condensers by observing the voltmeter response to the potential applied in series with the condenser under test. This method is in addition the means for testing condensers by a charge and discharge through the d.c. voltmeter.

Regardless of the technical knowledge possessed by a serviceman, he needs the proper equipment to make his task—keeping radio receivers happy—simple and efficient. The writer has found that the Supreme Diagonometer enables all necessary measurements that are necessary in service to be made expeditiously and without stumbling about to discover where trouble lies.

TYPE 360 TEST OSCILLATOR



One of the new test oscillators for the radio service laboratory is now ready. It will deliver a modulated radio-frequency voltage at any point in the broadcast band (500 to 1500 kilocycles) and at 175 and 180 kilocycles. The tuning control is calibrated with an accuracy of 2 per cent.

The Type 360 Test Oscillator is intended to be used for neutralizing, ganging, and tuning of the radio-frequency stages in a receiver, and it is fitted with an output voltmeter for indicating the best adjustment. This voltmeter is of the copper-oxide rectifier type, and by means of a switch it may be connected across a 4000-ohm load or across the dynamic speaker of the receiver when making tests.

Price \$110.00

GENERAL RADIO COMPANY

30 State Street

Cambridge, Massachusetts

ROBERT S. KRUSE

Consultant and Technical Writer

103 Meadowbrook Road, West Hartford, Conn.

Telephone Hartford 45327

**SMOOTHES OUT
RADIO VOLTAGE
"BUMPS"**

Automatically!

The new AMPERITE for electric radio automatically prevents fluctuating line voltage which interferes with radio reception. Delivers to your radio, exactly the voltage required for efficient operation. Greatly improves tone and sensitivity. Saves tubes. Insist on AMPERITE in the electric radio you buy or build. No radio can be modern without it.

FREE—Useful AMPERITE Bulletin and list of AMPERITE-equipped radios. Write Dept. RB 2

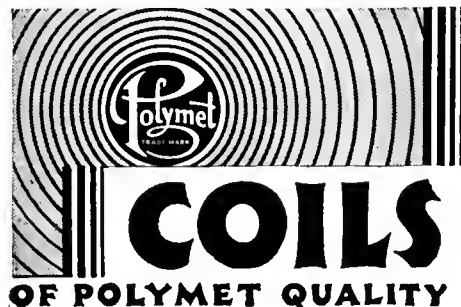

The Coilton Division of Polymet is a modern expansion of the oldest exclusive coil-winding plant in the electrical industry. New buildings, machinery, and equipment, with close engineering supervision of production, insure an exactness of coil performance justifying the designs of engineers and the judgment of purchasing agents.

Coils to manufacturers' specifications for Transformers, Speakers, Chokes, and every electrical device.

COILTON DIVISION EASTON, PA.
(Coil Windings exclusively)

STRAND & SWEET DIVISION
(Magnet Wire exclusively)
WINSTED, CONN.

Address all communications to

Polymet Manufacturing Corp.
337 E. 134th St., New York City

— [World's Largest Manufacturers of Radio Essentials] —

Condensers Resistors Volume Controls
Coils Transformers Magnet Wire

No. 325

RADIO BROADCAST Laboratory Information Sheet

February, 1930

Extra Money!

For Service Men

Extra
Enjoyment
for
Construction
Fans



RETURN COUPON
FOR FREE BOOKLET!

You know dozens of people who cannot (or will not) buy a 1930 receiver, but who still spend a reasonable amount to secure 1930 tone quality. This free booklet tells about the profit possibilities of modernizing old sets with new Pilot transformers.

PILOT RADIO & TUBE CORP.
323 BERRY STREET, BROOKLYN, N. Y.

PILOT RADIO AND TUBE CORP.
323 Berry Street, Brooklyn, N. Y.

Send me without obligation "A 1930 Voice For Old Sets"

NAME.....
ADDRESS.....
CITY..... STATE.....

A Radio Parts Guide

THE NEW
YAXLEY

Catalog



Send for it today for complete listings of Radio Convenience Outlets, Connector Plugs, Rheostats, Fixed and Grid Resistances, Jacks, Jack Switches, Phone Plugs, etc.

YAXLEY MFG. CO.

Dept. B, 1528W Adams St., Chicago, Ill.

MEN ARE IN DEMAND In All Branches of Radio



Prepare through a school with a reputation for efficiency. Our courses are easy, interesting and effective.

We have large classrooms, laboratory, workshop, dormitory and many other new and unusual features.

Subjects Taught:

COMMERCIAL RADIO RADIO SERVICE
RADIO BROADCAST VITAPHONE-MOVIE TONE
LABORATORY RADIO MATHEMATICS NAVIGATION

Literature on Request

COMMERCIAL RADIO INSTITUTE
38 W. BIDDLE ST. FOUNDED 1920 BALTIMORE, MD.

Beat-Frequency Oscillator

AN ARTICLE entitled "The Frequency Characteristics of Telephone Systems and Audio Frequency Apparatus, and Their Measurement," written by B. S. Cohen, A. L. Aldridge, and W. West, and published in the September, 1926, *Proceedings of the Wireless Section of The Institution of Electrical Engineers, England*, gives the circuit and constants of a beat-frequency oscillator for use in making measurements on telephone apparatus. This circuit is reproduced on "Laboratory Sheet" No. 326.

Each high-frequency oscillator circuit comprises a grid coil, L_2 , of 50,000 microhenries coupled to a plate coil, L_1 , of 20,000 microhenries and tuned by a fixed condenser, C_1 , of about 0.001 mfd. A variable condenser, C_2 , with a maximum value of 0.005 mfd. is connected in parallel with condensers C_1 to cover a frequency range of about 5000 cycles. The output coils, L_3 , each of 10,000 microhenries, introduce the high frequencies from each oscillator into the high-frequency amplifiers, V_2 —the use of these high-frequency amplifiers serves to prevent interaction between the two oscillators. The coupling between the output of the high-frequency amplifiers and the detector is obtained through a coupling condenser, C_4 , and the two-megohm leak in the grid circuit of the detector tube. The detector,

V_3 , is of the plate-rectification type. In the plate circuit of the detector is a low-pass filter having a cut off at about 20,000 cycles. The filter functions to reduce to negligible values the high frequencies in the output of the oscillator. Two stages of resistance-coupled amplification are used between the detector and the output of the oscillator.

With a special output transformer it was still found that there was a tendency for the output to fall off at high frequencies. This was corrected by reducing the output at low frequencies to the value obtained at high frequencies. This was accomplished by means of an 0.2-henry air-core inductance, L_4 , in the plate circuit of the amplifier V_4 . In series with the inductance is the variable non-inductive resistor, R_4 , which in combination with the choke coil produced the desired rising frequency characteristic so that a uniform output could be obtained.

The harmonic output determined by means of an oscillograph was found to be less than 5 per cent, and could be further reduced by connecting a condenser in shunt across the input to the detector tube. This provided in the plate circuit of the high frequency amplifier tubes a lower impedance for the harmonics than for the fundamental and tended to improve the wave form of the high frequencies impressed on the detector tube.

No. 326

RADIO BROADCAST Laboratory Information Sheet

February, 1930

Beat-Frequency Oscillator

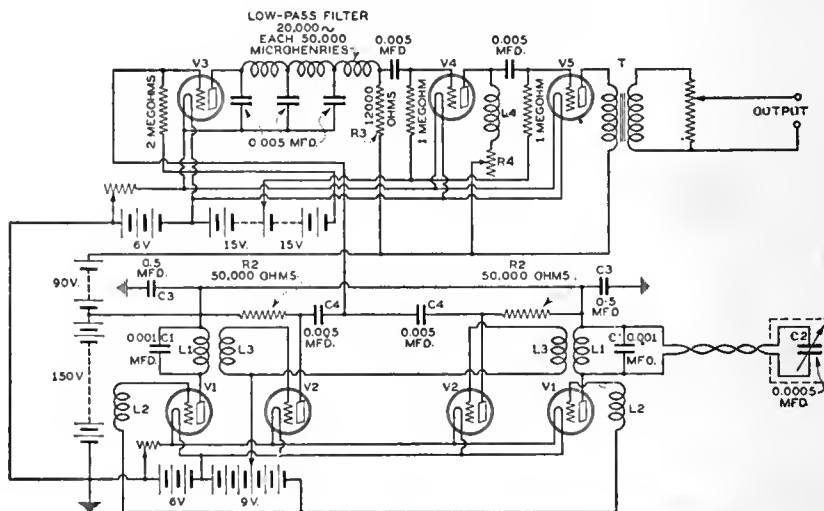

No. 327

RADIO BROADCAST Laboratory Information Sheet

February, 1930

Fidelity in Modern Receivers

THE ONLY way the user of modern radio apparatus can make his receiver distort is by (a) not tuning it accurately to the station to be received and (b) increasing the volume to the point where overloading occurs in one or more of the tubes. Distortion due to (b) rather than (a) is most generally found in practice, but trends in receiver design are gradually leading to receivers in which the tubes cannot be overloaded. Such receivers cannot be made to produce distortion other than that inherent in the characteristics of the circuit or that produced by improper tuning.

Tube overloading generally takes place in the detector and power tube long before it becomes serious in any of the other tubes. The task, therefore, is to design sets in which the amplified audio-frequency output of the detector is sufficient to apply the maximum permissible voltage to the grid of the power tubes (the maximum permissible voltage being limited by distortion in the power tube) and to include some method making it impossible to apply signal voltages in excess of the maximum permissible value to the power tube.

To design such a set we must first determine the maximum a.c. voltage which may be impressed

across the power tube before distortion occurs. We then work back through the a.f. amplifier and detector tube. Then, knowing the rectification characteristics of the detector tube, we can determine the maximum r.f. voltage which must be impressed on the detector. In order to impress on the detector a value of r.f. voltage which, when rectified and amplified, will impress the maximum permissible voltage across the power tube, automatic volume control circuits must be used. In such sets it is a function of the automatic control circuits to limit the detector input to this predetermined value regardless of the value of the field strength. Therefore, such a receiver cannot be overloaded.

The manual volume control in such a receiver is located in the a.f. amplifier so that the desired portion of the a.f. voltage from the detector may be impressed on the power tube. However, the design should be such that it is impossible to apply sufficient a.f. voltage to overload the power tube. The automatic volume control circuit which limits the maximum value of the a.f. output from the detector makes such a design possible.

RADIO NEEDS YOU

Let RCA Institutes show you the way to SUCCESS in this fast-growing industry

REACH out for a big-pay job in Radio... Tie-up to the fastest-growing industry in the world today... See for yourself what other men have done... You, too, can do the same! Hundreds of fellows just like you are now earning from \$2,000 to \$25,000 a year in RADIO. J. H. Barron, Radio Inspector of the U. S. Department of Commerce says that a most serious shortage in trained Radio men exists right now. Thousands of trained men are needed. Broadcasting stations, manufacturing plants, retail and wholesale dealers, as well as ships at sea and planes in the air, require trained Radio men.

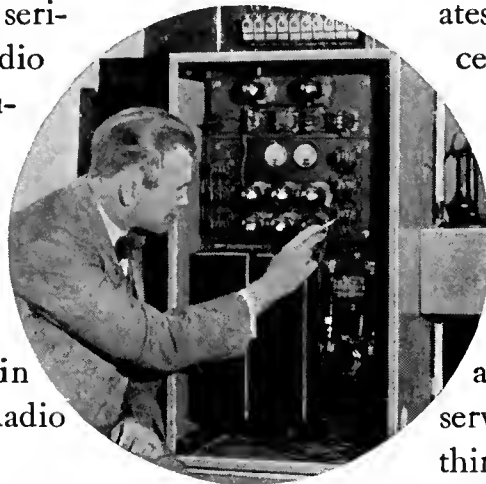

Radio Mechanics earn up to \$4,800 a year.

*Learn Radio at Home...
RCA Institutes Will Train
You for Success!*

RCA sets the standards for the entire radio industry. The RCA Institutes Home Laboratory Training Course gives you the real, inside, practical training in Radio, quicker than you could obtain it in any other way. It's easy to learn at home in your spare time. You get your lessons and criticisms direct from RCA... the

very source of radio achievement... the vast world-wide organization that has made Radio what it is today... that sponsors every lesson in this course.

RCA Graduates Find it Easy to Fill Good Radio Jobs

There has been a radio job for practically every graduate of RCA Institutes. Graduates are actually *Trained* for Success because they learn radio by actual experience with the RCA Institutes famous outlay of apparatus given to every student of this course. You learn to solve every radio problem such as repairing, installing, and servicing finesets. Here is everything you need know in order to fill a well-paid position in Radio.

*Send for this Free Book
"Radio... the Field of
Unlimited Opportunity"*

Read these 40 fascinating pages, each one packed with pictures and text that tell you everything you want to know about the many brilliant opportunities in Radio and about RCA Institutes, the world's oldest and largest radio training organization. Tune in on Radio. Send for this free book today and speed up your earning capacity!

Clip this Coupon NOW!

RCA INSTITUTES, INC.

Formerly
Radio Institute of
America



RCA INSTITUTES, Inc.
Dept. RB-3, 326 Broadway, New York

Gentlemen: Please send me your FREE 40-page book which illustrates the brilliant opportunities in Radio and describes your laboratory-method of instruction at home!

Name

Address

RADIO BROADCAST

WILLIS KINGSLEY WING Editor
 HOWARD E. RHODES Technical Editor
 EDGAR H. FELIX Contributing Editor

VOL. XVI, NO. 5



PUBLISHED FOR THE RADIO INDUSTRY

Contents for March, 1930

Review - - - - -	-W. K. W.	251
Important Events Distribution New Models Broadcast Advertising	In Lawyerland New Tubes? Revelation The Service Gospel	
A D.C. to A.C. "Converter" - - - - -	Frank G. Logan	252
Characteristics of Pentode Tubes	Keith Henney and Howard E. Rhodes	254
Automobiles With Radio - - - - -		256
The March of Radio - - - - -	-An Editorial Interpretation	258
The Jellyfish Commission	"A Pateot Pool for Public Service"	
Volume Control in Broadcasting - - - - -	O. B. Hanson	260
High-Frequency Measuring Equipment - - - - -	H. D. Oakley	262
Magnetic Circuit Design - - - - -	E. A. Uehling	265
"Radio Broadcast's" Engineering Review Sheets - - - - -		267
No. 31. Radio Galvanometers	No. 32. Radio Galvanometers (continued)	
The Serviceman's Equipment - - - - -	J. H. Miller	269
Three Years With the Federal Radio Commission	Louis G. Caldwell	270
Strays From the Laboratory - - - - -	Technical Shorts	273
Square-Law Detectors Capacities of Coils Changes in Stations	Quartz Crystals A Correction Recent Articles of Interest	
Production Testing Equipment - - - - -	J. A. Callanan	274
Rating Radio Receivers - - - - -	Alfred H. Grebe	276
Tricks With Set Testers - - - - -	Herbert M. Isaacs	278
Professionally Speaking - - - - -	Keith Henney	281
Regarding Pentode Articles Are Technical Salesmen Needed?	Improvements in Monitoring	
The Serviceman's Corner - - - - -		284
Artificial Q R N 245 Tubes in Radiolas Sales Dope for Servicemen	Getting Acquainted With A K Points on Installation	
"Radio Broadcast's" Service Data Sheets - - - - -		288, 290
Crosley Models 40S, 41S, 42S, 82S	The Erla Model 224	
Book Review - - - - -	Robert S. Kruse	291
News of the Radio Industry - - - - -		294
In the Radio Marketplace - - - - -		298
Radio Broadcast Laboratory Information Sheets	Howard E. Rhodes	300, 302, 304
No. 328. Loud Speaker Bibliography	No. 333. Calculating Power Output	
No. 329. Loud Speaker Bibliography	No. 334. Calculating Power Output	
No. 330. Loud Speaker Bibliography	No. 335. Undistorted Output vs. Dynamic Range	
No. 331. Modulated Oscillator and Output Meter	No. 336. Undistorted Output vs. Dynamic Range	
No. 332. Modulated Oscillator and Output Meter		

. . . among other things

FRANK G. LOGAN, who describes the Ward Leonard "Adaptoron" in this issue has been connected with the radio division of the company for many years. Mail reaches him at Mt. Vernon, New York. . . . O. B. Hanson, writing on volume levels in broadcasting, has been active in the technical side of broadcasting since "way back when." Mr. Hanson was with WEAJ when its towers dominated 24 Walker St., New York, followed its fortunes to 195 Broadway, and when the National Broadcasting Company took WEAJ unto its heart from the Telephone company, Mr. Hanson was made manager of plant and operations. . . . Edwin A. Uehling's article on magnetic circuit design in this number is one of those unusual articles which you may expect to find in RADIO BROADCAST. Mr. Uehling is a graduate of Wisconsin and has been with the Bell Laboratories, Grebe, and Fada. He is now in the Graduate School, University of Michigan. . . . For the past five years, H. D. Oakley, while he has been employed by General Electric, has been engaged in the invention and development of high-frequency measurement apparatus. Associated with Mr. Oakley are H. J. Schrader and G. S. Jacobs. Their enthusiastic interest and ability for this sort of work is responsible for much of the advancement which has been made in the creation of measurement tools and technique, Mr. Oakley tells us.

IN APRIL, the story about phonograph record-changing mechanisms by Thomas Piazza, promised for this issue, will appear. Other articles will include: E. L. Brown, aircraft radio development; Jesse Marsten, high-frequency response; Von Ardenne, use of the cathode-ray tube to measure percentage of modulation; Mancill, describing construction of a laboratory and testing apparatus used; Oakley, input and output audio-frequency measuring apparatus; and an article from American Bosch describing the design and characteristics of their automobile radio receiver. All the regular departments for service and practical workers will appear, as usual.

THROUGH ONE of those often unexplicable and always embarrassing typographical errors, the formula appearing in the article by Ernest Amy and J. G. Aceves on page 206 of our February issue was made to read $\frac{1}{\sqrt{LC}}$. This, as most readers know, should be $f = \frac{1}{\pi\sqrt{LC}}$

TERMS: \$1.00 a year; single copies 35 cents; All rights reserved. Copyright, 1930, in the United States, Newfoundland, Great Britain, Canada, and other countries by

DOUBLEDAY, DORAN & COMPANY, INC., Garden City, New York

MAGAZINES
 COUNTRY LIFE WORLD'S WORK THE AMERICAN HOME RADIO BROADCAST SHORT STORIES LE PETIT JOURNAL EL ECO WEST
 BOOK SHOPS (Books of all Publishers)

NEW YORK: <LORD & TAYLOR, JAMES McCREERY & COMPANY, PENNSYLVANIA TERMINAL, 166 WEST 32ND ST., 848 MADISON AVE., 51 EAST 44TH STREET, 420, 526, and 819 LEXINGTON AVENUE, GRAND CENTRAL TERMINAL, 10 WALL STREET> ATLANTIC CITY: <2807 BOARDWALK> CHICAGO: <75 EAST ADAMS STREET> ST. LOUIS: <310 N. 8TH ST. and 4914 MARYLAND AVE.> CLEVELAND: <HIGBEE COMPANY> SPRINGFIELD, MASS: <MEEKINS, PACKARD & WHEAT.

OFFICES

GARDEN CITY, N. Y.: NEW YORK: 244 MADISON AVENUE. BOSTON: PARK SQUARE BUILDING. CHICAGO: PEOPLES GAS BUILDING. SANTA BARBARA, CAL. LONDON: WM. HEINEMANN, LTD. TORONTO: DOUBLEDAY, DORAN & GUNDEY, LTD.

OFFICERS

F. N. DOUBLEDAY, Chairman of the Board; NELSON DOUBLEDAY, President; GEORGE H. DORAN, Vice-President; RUSSELL DOUBLEDAY, Secretary; JOHN J. HESSIAN, Treasurer; LILLIAN A. COMSTOCK, Ass't Secretary; L. J. McNAUGHTON, Ass't Treasurer

THE NEW HOME OF SPRAGUE CONDENSERS • NORTH ADAMS, MASS.

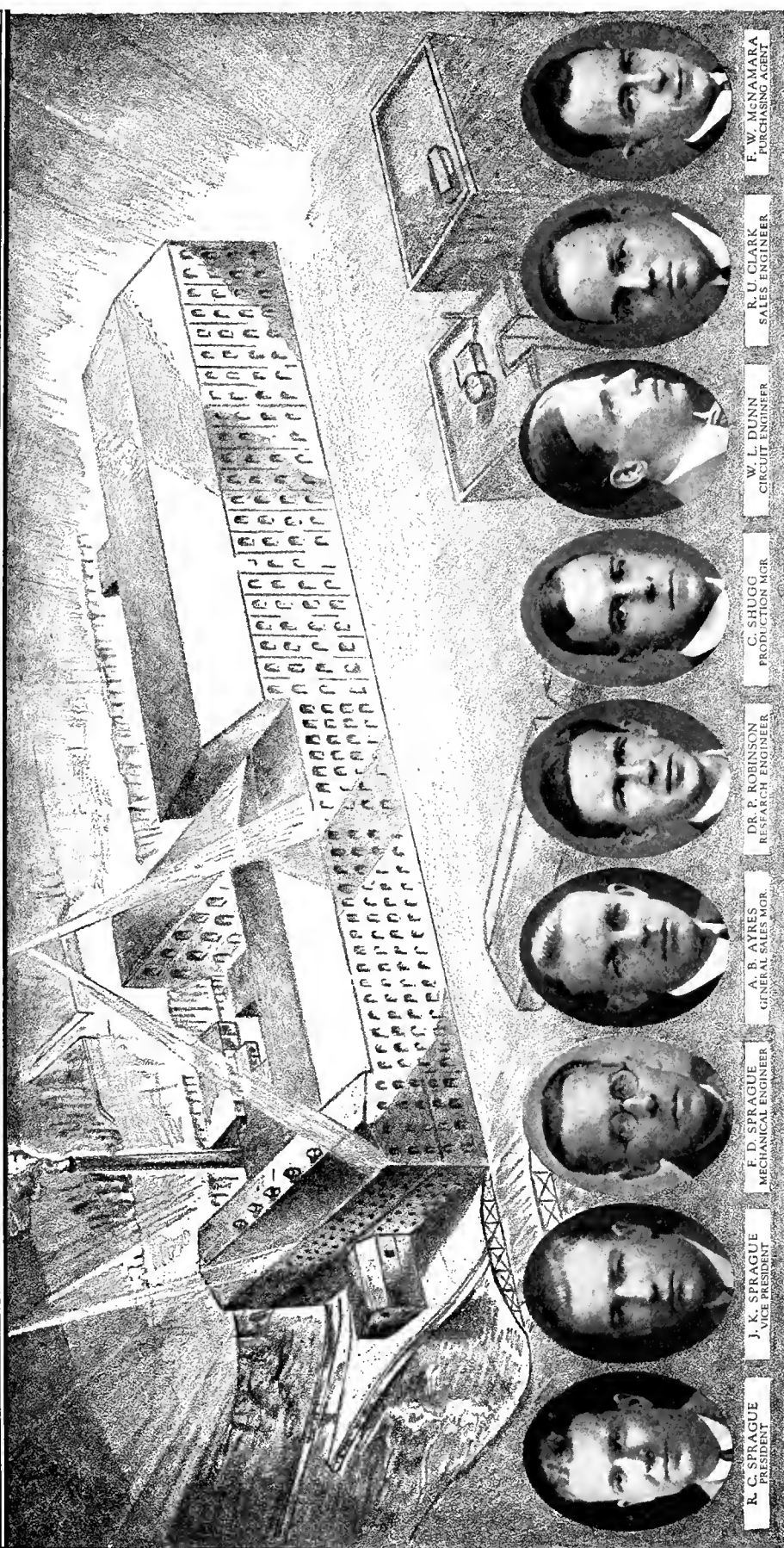

F. W. McNamara
PURCHASING AGENT

R. U. Clark
SALES ENGINEER

W. L. Dunn
CIRCUIT ENGINEER

C. SHUGG
PRODUCTION MGR.

DR. P. ROBINSON
RESEARCH ENGINEER

A. B. AYRES
GENERAL SALES MGR.

F. D. SPRAGUE
MECHANICAL ENGINEER

J. K. SPRAGUE
VICE PRESIDENT

R. C. SPRAGUE
PRESIDENT

GENTLEMEN

HAVE YOU A
CONDENSER
PROBLEM *in your
lab?*

IF SO *we can
help you.*

WE HAVE
very extensive
RESEARCH LABS
headed by

CAPABLE ENGINEERS
*specializing in the
application and production
of*

ELECTROLYTIC *and*
PAPER CONDENSERS

TO
HELP DESIGN AND
PRODUCE A-1
FILTER SYSTEMS
AT A LOWER COST.

HOW ABOUT
PRODUCTION?

120,000 SQUARE FEET
in our new

PLANT *devoted entirely
to the manufacture of
condensers.*

WE ARE ONE SPECIALIST
it costs nothing

TO CONSULT.

YOU ARE *both*
JUDGE *and*
JURY.

HOW ABOUT
A TRIAL?

SPRAGUE SPECIALTIES COMPANY QUINCY, MASSACHUSETTS

SOME SPRAGUE ELECTROLYTIC OR PAPER CONDENSER
WILL SOLVE YOUR CONDENSER PROBLEMS





*Saving Cents
versus
Making
Dollars*

ONE conspicuously successful radio manufacturer, whose name is a by-word in America, has risen to the position because he insists upon building his product as well as he know how to build it. In that plant any suggestion that a few cents can be saved, by buying parts or materials not thoroughly approved, is quickly frowned upon.

Permanency in a fast-changing industry can be attained only by building a genuine and accumulative good will over a period of years.

You will secure in Dongan Power Parts the most recent developments that will stand the acid test of performance. Not the lowest in price—but the finest Power Parts that can be made by an organization which has devoted twenty years to the single purpose of designing and building fine transformers.

*Exclusively M'frs
of Parts for the
Set Manufacturer*

*Transformers
Chokes
Condenser Units*

Dongan Electric Manufacturing Co.

2991-3001
Franklin Street



Detroit
Michigan

Service

*Big
Profits
in it with
Reliable
Equipment*

"A penny saved is a penny earned" is not true in purchasing instruments for radio servicing work. The small difference in cost between the best obtainable meters and those of secondary value comes back to you many times over in the money you can make and the business reputation you acquire through the use of reliable equipment.

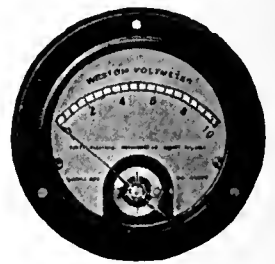

Shown herewith are two designs of miniature panel instruments—2" and 3 1/4" diameter—for use in the repair shop and in portable testing work. These are the instruments selected by Commander Byrd for his Polar expeditions. Preferred for their nicety of construction and superior electrical characteristics.

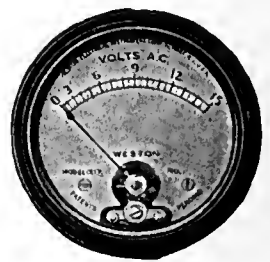

Made in A. C., D. C. and Thermo-Couple Types, and in all the required ranges. Open scales almost to zero position. Designed for flush panel mounting. Write for Circular JJ, containing complete descriptions and prices.

Weston INSTRUMENTS

PIONEERS
SINCE 1888
WESTON ELECTRICAL
INSTRUMENT CORPORATION

604 Frelinghuysen Ave.

Newark, New Jersey

Fulco RADIO COVERS



ON AND OFF
IN A JIFFY



"FULCO" covers are used by those dealers who realize the importance of making deliveries in perfect condition — without scratches or mars. For they know that complaints mean dissatisfied customers and loss of business.

"FULCO" covers are a real service feature that helps sales and holds trade. Substantially constructed, heavily padded, box-shaped, providing perfect protection. Give us the dimensions of radios handled and let us quote special prices on your individual needs. Write our nearest house.

Fulton Bag & Cotton Mills

Manufacturers Since 1870
ATLANTA · NEW ORLEANS · DALLAS · ST. LOUIS
MINNEAPOLIS · BROOKLYN · KAN. CITY · KAN.

REVIEW

◀ **IMPORTANT EVENTS**—National Carbon retires from receiving set field, unloading sets throughout the country at less than half of list price. List of Radio Corporation tube licensees mounts to 12 with addition of Triad, of Pawtucket. (Others: Allen, CeCo., Champion, Hygrade Ken-Rad, La Salle, National Union, Sylvania, Raytheon, Tung-Sol, and United Radio). Revelations continue in Washington before Senate Interstate Commerce Committee with B. J. Grigsby, of Majestic, saying that the industry is badly hampered by the clouded and unhappy patent situation and the effect of the RCA licensing policy, and Oswald F. Schuette revealing list of 54 members of the Radio Protective Association. (RADIO BROADCAST, February, p. 199.) International broadcasting renewed on January 21 with great success. Four more companies reported in receivership proceedings, increasing the total to thirteen. New companies Temple, Kolster, DeForest, Balkeit. (De Forest receivership petition was dismissed on February 5.) Others; Earl, Freed, A. C. Dayton, Marti, Neonlite Tube, Buckingham, United Reproducers, Erla. McGraw-Hill announces new magazine, *Electronics*, to appear in April. The publication will cover technically, the entire field in which the vacuum tube is used.

◀ **DISTRIBUTION**—RCA-Victor Corporation is reported planning exclusive distributor policy with merchandising of Victor sets to continue as before. The Camden plant of RCA-Victor will produce both Victor and RCA sets, the latter to be marketed under four trademarks: Radiola, Greybar, General Electric, and Westinghouse. Brunswick reported returning to the jobber system.

◀ **NEW MODELS**—In spite of the unhappy position of some manufacturers who are moving present stocks of merchandise announced about the middle of last year, five manufacturers have announced new models; Majestic, Philco, Silver, Zenith, and Stromberg. Several other makers may follow soon.

◀ **BROADCAST ADVERTISING**—President Aylesworth, N.B.C., states to Senate Committee that broadcast advertising while successful must be carefully guarded against excesses. Excesses reported from the West Coast. (RADIO BROADCAST January, p. 126.) Writes our private detective from Los Angeles:

SOME OF the events in the world of radio in recent weeks may have escaped you. A few of the more important, to our way of thinking, are presented on this page.

"If you think some East Coast advertisers lay it on thick, you should hear some of the three-minute, wheedling, direct-selling discourses which the announcers here put on between about equal intervals of canned music. However, a reaction may be setting in." Evidence: advertisement of Silverwoods, Los Angeles, from a recent issue of the *Los Angeles Times*. "Listen to Silverwoods 'No-Advertising' program over KJL. . . . We have determined upon a change of policy in our radio programs. Beginning to-night, there will be *no advertising* . . . When you extend to us the courtesy of listening to our program . . . we become a *guest* in your home. . . . We think there is too much intrusion of advertising over the radio to-day and are pleased to do our small part toward correcting this situation."

◀ **IN LAWYERLAND**—The Supreme Court refuses to review the decision of the Circuit Court of Appeals, Second district, in *Wildermuth vs. Hazeltine Corp.* case (Atwater Kent-Hazeltine). Hazeltine brought suit on patent No. 1,538,858 said to cover grid circuit neutralization. The decision favored Hazeltine. Atwater Kent is now moving to reopen the case on the ground of new evidence. RCA sues De Forest and Universal Wireless Communication in the Federal Court at Wilmington on certain communications patents. DeForest sues Grigsby-Grunow on their Coyer patent relating to the winding of grid electrodes in tubes.

◀ **NEW TUBES?**—Considerable interest evidenced in the pentode tube. Three American makers have produced experimental models: Arcturus, Champion, and CeCo. January 15th meeting of the Radio Club of America addressed by Keith Henney and Howard Rhodes of RADIO BROADCAST with a paper describing measurements on experimental American tubes and probable receiving set application. The meeting was well attended by tube and set makers. Appearance of a tube in commercial quantities is practically certain but its probable influence on set design of 1930 is not.

◀ **REVELATION**—Fifty four companies made up Oswald Schuette's very vocal Radio Protective Association. Of the fifty four, twenty three companies have now merged, resigned from the Association, or are in the hands of receivers. Of the thirty one remaining, seven are set manufacturers: Advance Electric, Los Angeles; Metro Electric, Chicago; Premier Electric, Chicago; Shamrock Mfg. Co., Newark; Sparks-Withington, Jackson; Tyrman, Chicago; Wilcox Laboratories, Charlotte, Mich. The other active members are: Callite Products, Union City, N. J.; Cardon Phonograph Corporation, Jackson, Mich.; Davis Industries, Chicago; Diamond Electric, Newark; Duovac, Brooklyn; Duratron Products, Union City, N. J.; Eisler Electric, Newark; Gold Seal, New York; Halldorson, Chicago; Oxford, Chicago; Parker-McCrory, Kansas City; Perryman, New York; Pilot Radio and Tube, Brooklyn; Polymet, Brooklyn; C. H. Quackenbush, Cleveland; Radio Electric Works, New York; Schickerling Products, Newark; Scranton Button Works; Sonatron Tube, Chicago; Specialty Appliance, Cleveland; Transformer Corp of America, Chicago; Triad, Pawtucket; United Scientific Laboratories, New York; Van Horne Tube Company, Franklin, Ohio; Vesta Battery Corporation, Chicago; Western Coil and Electrical Company, Racine, Wisconsin.

◀ **THE SERVICE GOSPEL**—Substitute "radio" for "car" in the following: "In the Ford Motor Company, we emphasize service equally with sales. It has always been our belief that a sale does not complete the transaction between us and the buyer, but establishes a new obligation on us to see that his car gives him service. We are as much interested in your economical operation of the car as you are in our economical manufacture of it. This is only good business on our part. If our car gives service, sales will take care of themselves. For that reason we have installed a system of controlled service to take care of all Ford car needs in an economical and improved manner. We wish all users of Ford cars to know what they are entitled to in this respect, so that they may readily avail themselves of this service."—From a full-page newspaper advertisement of the Ford Motor Company. How many radio manufacturers are there who could sign such a statement?

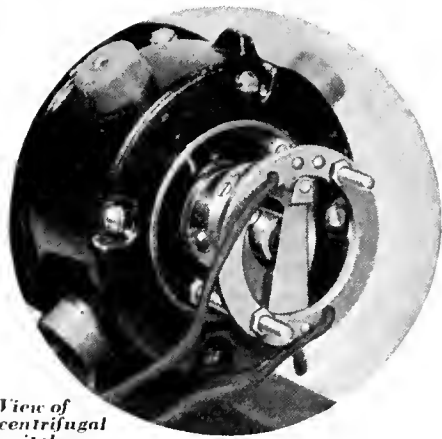

View of centrifugal switch

A D.C. TO A.C. "CONVERTOR"

A Device to Permit the Operation of A.C. Radio Receivers From a 32-, 110-, or 220-volt D.C. Supply. Efficiency Approximately 80 Per Cent.; Automatic in Starting; Quiet in Operation.

By **FRANK G. LOGAN**
Ward Leonard Electric Company

The engineering problems associated with the design of radio receivers for operation on d.c. have always been serious—the available voltage is limited, line noise has been hard to eliminate completely, and a d.c. receiver giving good results in one district may not give satisfactory operation in another location. On the other hand, the development of a special receiver for 110-volt d.c. operation is costly, and, since production is comparatively small, tool and production costs are higher. The power output is very limited in designs suitable for public use and the owner of a d.c. set who moves to an a.c. district must purchase an entirely new receiver.

In rural homes equipped with 32-volt farm-lighting systems either battery-operated receivers or a.c. sets with motor generators or rotary converters have been used in most cases. Motor generators or rotary converters in sizes suitable for use with radio sets which require only about 100 watts are quite inefficient, generally being not more than about 40 per cent. efficient. Therefore, a 100-watt a.c. set powered from a convertor connected with a 32-volt system places a load on the line of about 0.25 kva.—which is undesirably large for such systems are seldom rated at more than about 1 kva.

There is an obvious need for some device which will make it possible to build efficient sets for 32-, 110-, and 220-volt d.c. systems which will not cost much more, and which will give, in every way, a performance equivalent to that obtained from a standard a.c. receiver. Considerable work on such a device has been in progress at the laboratories of the Ward Leonard Company and a very satisfactory final design has been produced. This device is known as the Ward Leonard Adaptoron. A most important feature of this device is economy; the cost of an alternator or converter to supply 0.25 kva, is much in excess of the cost of an Adaptoron for equivalent duty.

Briefly, the Ward Leonard-Adaptoron consists of a specially designed rotating reversing switch which reverses the flow of current from the direct-current line 120 times per second. This gives the effect of a 60-cycle alternating current as it requires 1/60th of a second to go through a complete cycle, or reversal in both directions. The switch is in the form of a commutator with four brushes, the commu-

frequency ratio may be altered as desired.

The efficiency of this device is approximately 80 per cent. as compared with 50 per cent. delivered by the average motor-generator for radio and 40 per cent., or less, with the average rotary converter for radio use. The standard model is designed to carry loads of 0.125 kva., or less. This, roughly, is the equivalent of a radio receiver consuming 120 watts.

The output voltage is dependent upon the voltage of the direct-current line but, unlike motor-generator sets and converters is independent of motor speed. A variation of loads, within limits, causes little change in output voltage. On the average direct-current line of 115 volts ample a.c. voltage is supplied to the receiver using the low-voltage tap. For those who live in a district where the d.c. line voltage is low a booster transformer is supplied at slight additional cost. Such a transformer is also supplied with the 32-volt model.

Filters Prevent Interference

The design of the device not only includes adequate filters but the housing itself forms a double shield which prevents the radiation of electrical disturbances. A filter circuit is included in both the input and output circuits. This effectively prevents any disturbance arising in the device itself and a majority of the "line noises" from reaching the receiver and interfering with reception.

The small driving motor rotates at the comparatively low speed of 1800 r.p.m. This low speed reduces vibration and lessens bearing wear and brush loss. On the other hand, many motor-generators and rotary converters operate at speeds of 3600 r.p.m.

The motor of the Adaptoron is suspended from helical springs inside the case, thus preventing all motor vibration from being transmitted to the case. The freedom from noise due to this arrangement

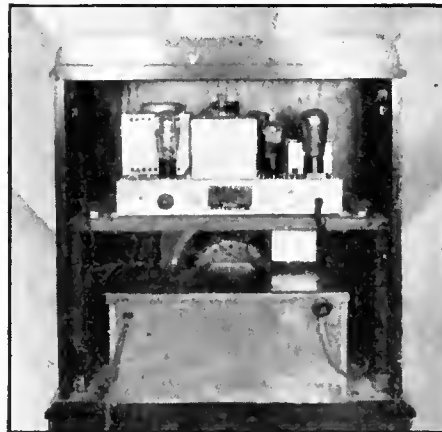

The Adaptoron installed in the battery compartment of a radio console cabinet.

tator being rotated by a small direct-current motor similar to those used in small hair driers, vacuum cleaners, and other household appliances.

By using a motor with fairly good speed-regulation characteristics, a frequency may be pre-selected and maintained within limits. The relation between motor speed and the frequency of the output voltage is—

$$f = \frac{r.p.m.}{30}$$

By other arrangements of the commutator segments and brush, this motor speed-

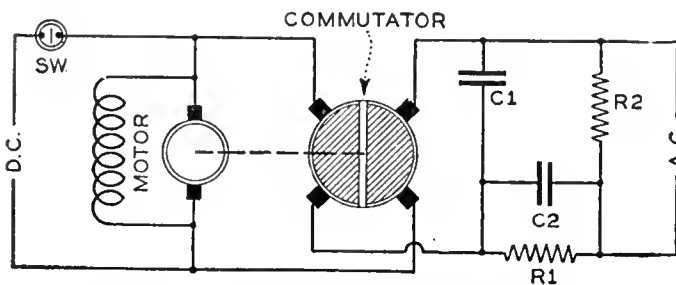

Fig. 1—The neon-tube Adaptoron circuit.

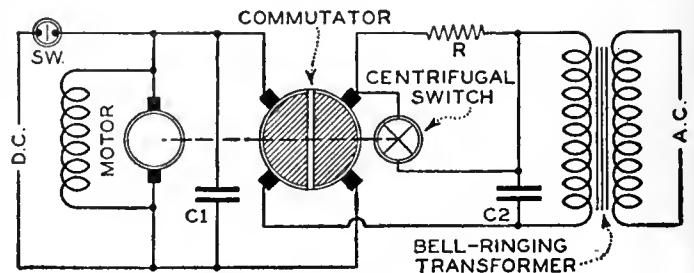

Fig. 2—The bell-ringing Adaptoron circuit.



Adaptoron equipment of the type used for purposes other than radio, that is, neon-light and bell-ringing circuits.

permits it to be placed near the radio receiver. In fact, it has been designed for placement in the console type cabinet which houses the receiver and loud speaker. As the driving motor may be wound for any direct-current voltage, models are furnished for operation upon 32-, 115-, and 230-volt direct-current lines.

The direct-current motor used has only one function in the circuit: To drive the special commutator at a constant speed. The power consumed in this service is small and it represents practically the entire inefficiency found in the device.

Centrifugal Switch

This device is self-starting. It requires only a simple switch as compared with the accessories required with motor-generators and converters. Since, if the d.c. supply to the special commutator were closed with the motor at standstill or rotating at a very slow speed, the d.c. line would be shorted across the primary of the power transformer, a small centrifugal switch is connected to the shaft of the motor. This switch does not close until the motor reaches about normal speed and as a result prevents the line from being shorted across the transformer primary.

The final design of the device was based on a number of measurements to indicate the effect of varying the length of the commutator segments and of varying the constants of the filter circuits associated with the input and output circuits. In

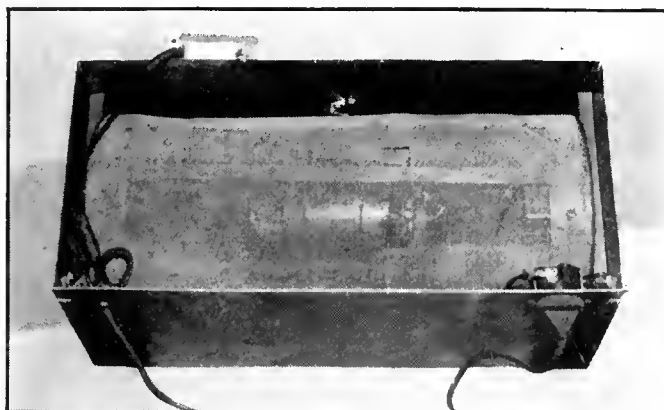

View of Adaptoron with front shield removed.

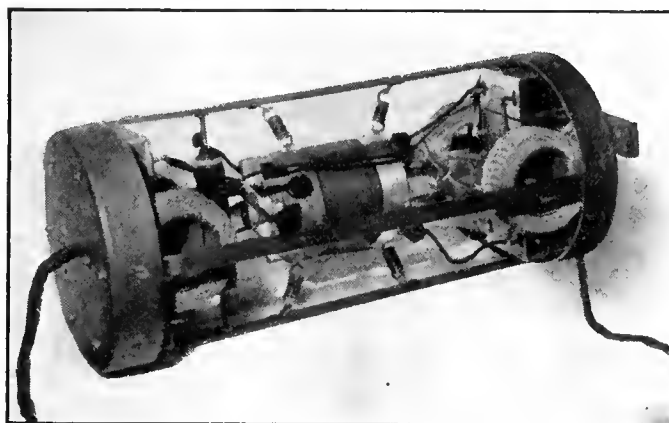

The Adaptoron chassis with both shields removed.

all cases the output of the device was connected to a step-up transformer with a turns ratio between the primary and the high-voltage secondary of 3.5 to 1. Across the secondary a 9800-ohm load resistor was connected. The measurements taken were the d.c. input voltage, the a.c. output voltage, the a.c. voltage across the secondary, and the wave form across the primary.

The first tests were made with a simple commutator system to determine the effect of varying the length of the commutator segments. Some of the wave forms obtained are indicated in Fig. 4 (page 302). It should be noted that the lengths of the segments are

given in electrical degrees. Since there are four segments, giving two complete cycles per revolution, the total electrical degrees in the circumference is 720°. Since all the segments are of equal length the maximum number of degrees per segment is 180°. The wave forms shown in curves 1, 2, 3, and 4 of Fig. 4 were obtained with segment lengths of 110, 130, 140, and 150 electrical degrees.

The area of the curves increases as the commutator segments are lengthened because of the greater length of time the circuit is closed. Increasing the segment length to 160 or 170 degrees caused the commutator to flash over. The sharp sides of the curves indicate the presence of a large number of harmonics and the succeeding experiments were made to determine the effect on the wave form of various filter circuits. A commutator length of 150° was chosen since it gave high efficiency without any tendency for the segments to flash over.

Filter Systems

Placing a condenser across the primary terminals (points 1 and 2 in Fig. 4) or a choke in series with the primary circuit caused excessive sparking at the commutator. Much better results were obtained by the use of filters containing both types of reactances. In Fig. 5 are some data and curves obtained by the use of the filter system indicated. A series of curves made with a choke in both legs instead of only one leg (as indicated in Fig. 6) gave a somewhat purer wave form, especially if the condenser had a capacity of more than 3 mfd. The wave form corresponding to a C of 16 mfd. approximates that of the final design for radio use. The short horizon near the beginning of each cycle is due to a defect in the commutator, and is, therefore, not present in the wave forms of the commercial units.

A double-section filter was next tried. The circuit, voltage readings, and wave forms are shown in Fig. 7. Various capacities were placed at the input and output of the filter circuit, and, as indicated, they had quite an effect on the wave form. The lowest curve for capacities of 3 mfd. at input and output evidently contained a large third harmonic (180 cycles) but not much of any other harmonics.

Variation of the load will, of course, (Continued on page 302)

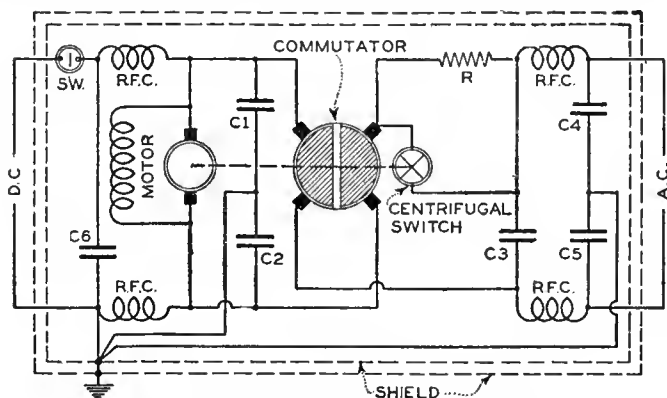

Fig. 3—The Adaptoron for radio use.

CHARACTERISTICS OF PENTODES

A Discussion of the Pentode With Particular Reference to the Characteristics of Some Experimental American Tubes. The Curves Given Include Static and Dynamic Characteristics, Power Output, etc.

By **KEITH HENNEY*** AND **HOWARD E. RHODES†**

*Director of the Laboratory and †Technical Editor, Radio Broadcast

Mention of the pentode tube first appeared in English and Continental radio publications in 1928 and 1929. Essentially it is a power output tube which, compared to a triode, delivers more a.c. power output per watt d.c. expended in heating the plate. At the same time it is more sensitive than triodes, i.e., it delivers more a.c. power output per a.c. volt input squared. The tube may have resulted as a natural development of tetrodes where secondary emission is bad or it may have been the result of the search for more economical power tubes. In this country there are already two kinds of five-element tubes. One is a power pentode and the other (CeCo) is a screen-grid pentode for r.f. or a.f. circuits.

Until very recently foreign pentodes delivered about 500-750 milliwatts when operated with 150-180 plate volts and with plate currents of the order of 10-15 milliamperes. The grid excitation required is roughly one tenth that required to deliver the same amount of power from a triode. Recently more powerful tubes have been developed; i.e., those using 300 volts on the plate and delivering 2000 milliwatts. Such tubes are made by Mullard, Philips, Marconi, etc.

In the United States the desire is not so much for greater economy as it is for greater power output. Hence the trend in experimental tubes so far is to increase the possible power output from a 250-volt tube. At the same time the

superior sensitivity of the pentode is a distinct advantage. It will eliminate the very large grid swing necessary to load up a push-pull amplifier using low- μ triodes.

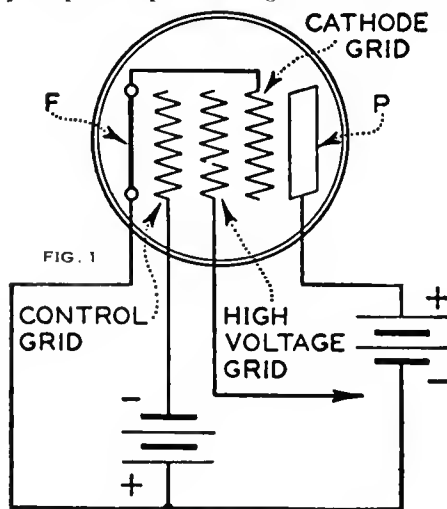

The pentode is a three-grid tube (See Fig. 1). One grid is the usual signal or control grid. The second grid, situated between the control grid and the plate, is a high-voltage grid. It has the effect of moving the plate nearer the filament and reducing the plate resistance. The third grid is very near the plate and is permanently connected to the filament. It is, therefore, at zero potential with regard to the d.c. and a.c. voltages within the tube. It is called the cathode grid and its purpose is to return to the plate any secondary emission from the plate. The arrangement of the five elements is indicated clearly in the diagram on the left.

Secondary emission is due to high-energy electrons striking the plate and knocking other electrons out of the latter element. The fact that a high-potential grid is in the path of the electrons speeds them up considerably and hence increases their kinetic energy. If, as in the screen-grid tube, there were no retarding influence between the plate and the positive or accelerating grid, these secondary electrons would find themselves in the field of the positive grid and would represent a decrease of plate current. The cathode grid which is at zero potential represents a wall over which the secondary electrons cannot or prefer not to jump. Therefore, they return to the plate.

The curves presented here are largely from an experimental tube developed in Arcturus laboratories. It

TABLE I

COMPARISON OF PRESENT POWER TUBES AND THE PENTODE FROM THE STANDPOINT OF SENSITIVITY, D.C. POWER INPUT, AND EFFICIENCY.

Tube	E_c	E_p	I_p	Output M_w	$\frac{M_w}{E^2}$	D.C. Power (Watts)	Eff. $\left(\frac{P_{a.c.}}{P_{d.c.}}\right)$	I_f Power
112A	9	135	7	120	2.9	0.945	12. %	1.25
171A	40	180	20	700	0.47	3.6	19.5 %	1.25
210	31	400	18	1325	2.73	7.2	18.4 %	9.4
250	84	450	55	4050	1.12	24.7	16.3 %	9.4
245	50	250	32	1600	1.27	8.0	20 %	3.75
PE 7	12	250	42	2200	30.5	10.5	21 %	3.75
150-Volt Pentodes	10	150	12	500	10.0	1.8	28 %	0.6 to 0.8

EF = output power ÷ input d.c. power

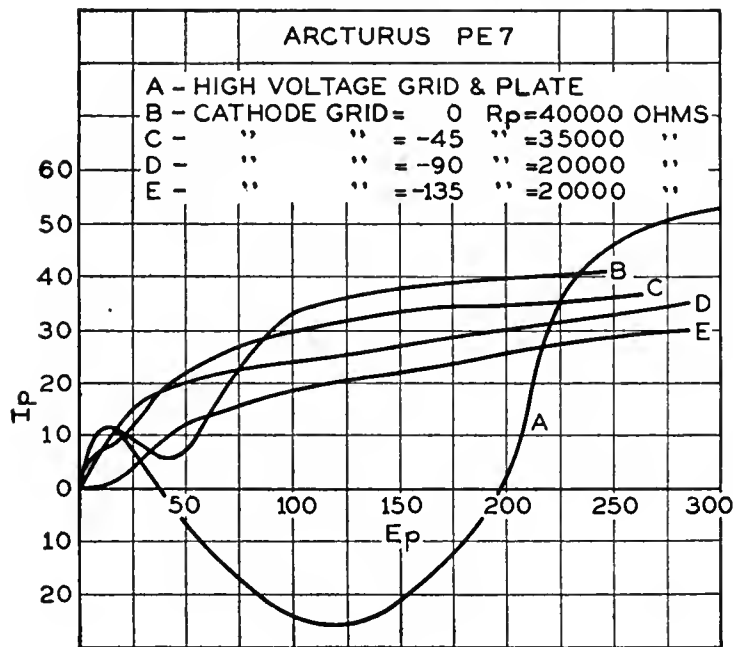

Fig. 2

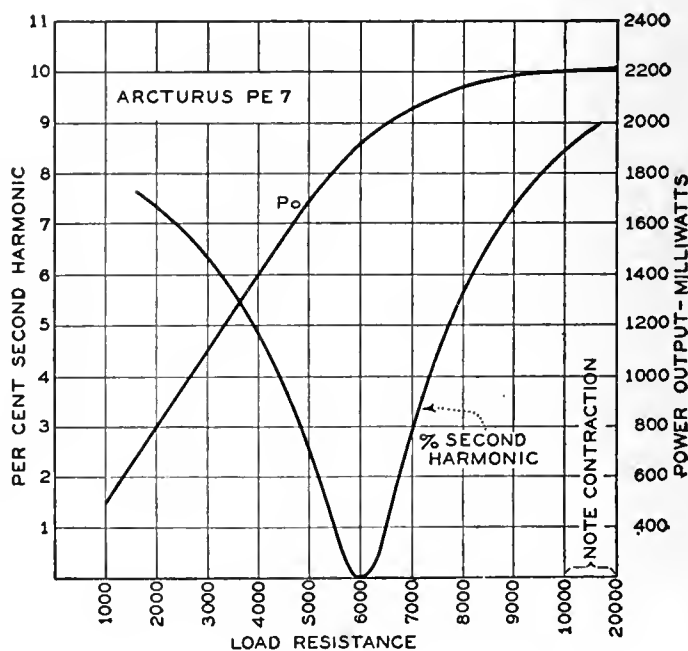

Fig. 3

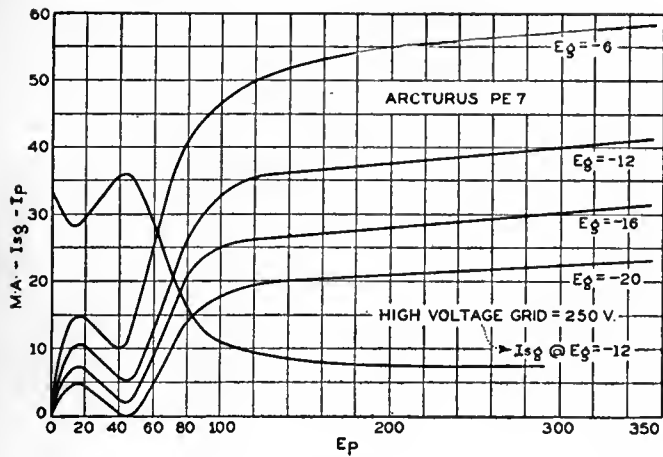

Fig. 4

will deliver about 2000 milliwatts with a plate current of about 40 milliamperes at 250 volts, and requires a grid voltage (a.c.) of only 12 volts peak. This may be compared to a 245-type tube which delivers 1600 milliwatts on approximately the same amount of d.c. power and with a grid voltage of 50 volts.

Characteristic Curves

Plate current-plate voltage characteristics of the Arcturus PE-7 tube are shown in Fig. 4. There is still some secondary emission at low plate voltages. The effect of varying the potential of the cathode grid is shown in Fig. 2. At high negative voltages on this grid, all the electrons are speeded back to the plate and there is no secondary emission.

While it is probably not correct to use the usual method of laying out load lines on the E_p-I_p curves to determine the proper load resistance and the second harmonic distortion, some idea of the respective values can be discovered by so doing. These data are presented here with the knowledge that they may mean very little indeed. Thus it may be calculated that the Arcturus experimental tube with an internal resistance of about 40,000 ohms will work best into a load resistance of from 4000 to 8000 ohms. Within these two values the second harmonics (according to usual methods of calculation) will be less than 5 per cent., the usual criterion for distortionless amplification. At the same time the power output does not increase appreciably for values of load resistance in excess of 8000 ohms. (Fig. 3).

It is probable that the third harmonics are the worst offenders in the pentode and at the present time there seems to be no generally accepted and easily worked method by which the percentage of third harmonics can be calculated from the characteristic curves.

Use of the Pentode

In Europe the pentode has been worked with magnetic loud speakers whose well-known impedance characteristics are anything but straight flat lines. As a rule the impedance of these loud speakers increases rapidly with frequency. Since greater and greater distortion is the result

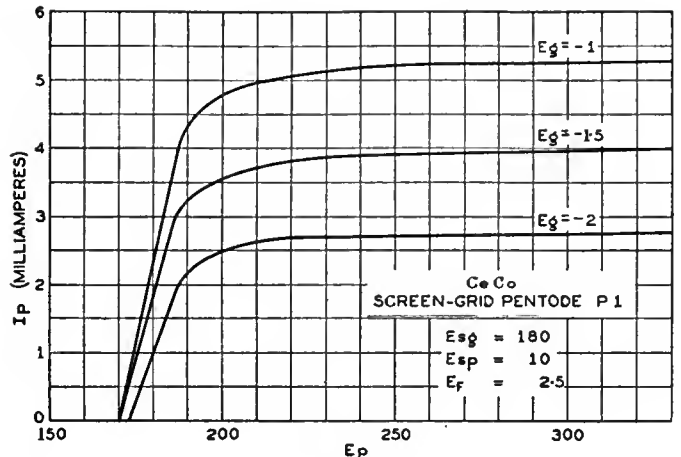

Fig. 5

of using a high-resistance load with the pentode, the fidelity of response is not very good. The high frequencies develop very high voltages across the load and within the tube, and are reproduced all out of proportion to the low tones.

In this country the magnetic loud speaker is practically on the shelf in favor of the

electrodynamic type which has a flatter impedance characteristic. Since the pentode should be worked into a load lower in resistance than itself, it can be coupled to an electrodynamic loud speaker through the same transformer which usually couples it to a 4000-ohm tube. In the Laboratory the fidelity from such a tube and a Peerless loud speaker compared very favorably with that obtainable from a 245-type tube, and with a given grid voltage input the output was some 15 db higher. In other words, feeding 12 volts into a 245-type tube produced about 100 milliwatts but the same voltage fed into an Arcturus pentode produced about 2000 milliwatts. This is a very appreciable difference in volume.

Practical Applications

One of the important applications of this tube may be in the detector socket as a true power detector. Thus it may be used with the loud speaker in its plate circuit. However, whether it will make a good power detector tube has not been determined by experiment. A glance at its grid voltage-grid current curve (Fig. 6) indicates that it will make a good grid-circuit detector. The problem then becomes one of obtaining sufficient power from it. Development of more efficient loud speakers will make it possible to eliminate the audio-frequency amplifier entirely and to use only the pentode as a power detector working directly into the loud speaker.

It has been suggested that the tube in this capacity might serve in automobile radio receivers and in other places where the space limitations are severe. The fidelity obtainable from a small loud speaker under the best conditions cannot be extremely good, and so the use of a small magnetic or electrodynamic loud speaker in connection with a pentode detector supplying perhaps 500 milliwatts may be an important application.

In this particular tube, which may not (Continued on page 293)

TABLE II

Name	E_f	I_f	R_p	M_u	G_m	E_p	E_s	E_c	I_p	P_o	I_s
Cossar 230	2	0.3	20×10^3	40	2000	180	120	9	14		1.6
415	4	0.15	20	40	2000	180	120	9	14		1.6
Marconi PT 240	2	0.40	55	90	1650	150	150	9	16	500	6.0
PT 625	6	0.25			1850	250	200	15	26.5	2000	7.0
Mullard PM 24	4	0.15	28.6	65	2300	150	150	12	12	500	3.0
PM 24A	4	0.275			1550	300	200	21	18	2000	5.0
PM 22	2	0.3	62.5	80	1300	150	150	10	13	350	3.5
Six Sixty ss 230 pp	2	0.3	64	80	1250	150	150	10	13	350	3.5
415	4	0.15	27	60	2200	150	150	12	12	500	3.0
4pen	4	0.275			1550	300	200	21	18	2000	5.0
Mazda 425	4	0.25			2000	150	150	12	18	750	5.0
Philips C443	4	0.25	40	60	1500	300	200	15	28		
PE 7	2.5	1.75	40	80	2000	250	250	12	40	2200	10.0

E_f —filament voltage
 I_f —filament current
 R_p —plate resistance
 M_u —amplification factor
 I_s —current to high-voltage grid

G_m —mutual conductance
 E_p —plate voltage
 E_s —high-grid voltage
 E_c —control-grid bias
 I_p —plate current
 P_o —power output (milliwatts)

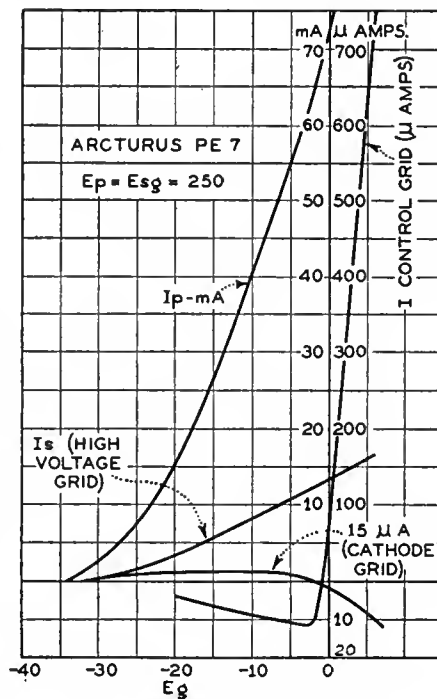

(Note change in grid current scale below abscissa.)

Fig. 6

TABLE III

	New CeCo Screen-Grid Tube	Present Screen-Grid Tube
Filament volts	2.5	2.5
Filament amperes	1.75	1.75
Control grid bias	(-) 1.5	(-) 1.5
Space-charge grid volts	(+) 10	(+) 10
Screen-grid volts	(+) 180	(+) 75
Plate volts	250	180
Mutual conductance	2300	1050
Plate resistance	250,000	400,000
Amplification factor	575	400
Plate current	3.9 ma	4.0 ma
Screen current	1.5 ma	
Space charge current	5.0 ma	
Maximum amplification (into 100,000 ohms)	164	84

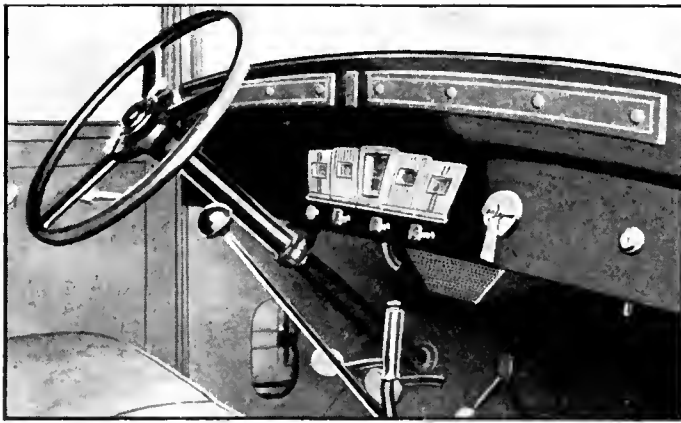

A Chrysler car equipped with a Transitone radio.

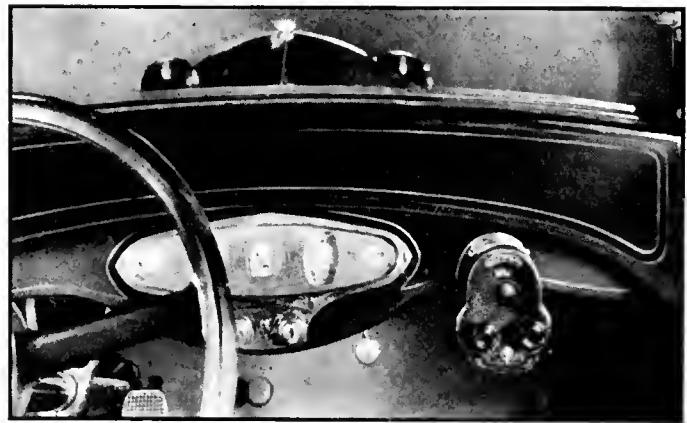

The Bosch radio control on the dash of a car.

AUTOMOBILES WITH RADIO

This Development, Which is Rapidly Gaining Headway, is Being Exploited by a Number of Manufacturers; Several Are Selling Cars With Radio as Standard Equipment While Others Provide Wiring to Facilitate Installation at Time of Sale. Three Manufacturers Make Suitable Equipment.

Opinions on the desirability of radio as a standard accessory in the automobile differ widely among passenger car manufacturers, but the question commands some consideration in practically all quarters where automotive topics are discussed.

Quite recently a number of automotive executives, whose interest in the radio-equipped car previously had been rather indifferent, have displayed a decided curiosity. There are a number of executives representing some of the largest automobile manufacturers, on the other hand, who admit doubt about the future of radio equipment, and who feel that the public should be given more time to manifest its attitude.

Since radio receiving sets first gained popularity in American homes, some seven or eight years ago, there have been individual cases of radio-equipped automobiles. These early examples, however, proved more of a novelty than anything else, and their use was restricted more or less to purposes of advertising. There were too many technical difficulties to be overcome and the cost of intensive experimental work was not recognized as commensurate with the likelihood of immediate demand by the public.

In recent years the radio has developed from a novelty and a luxury to something closely approaching the indispensable. The phenomenal expansion of the radio industry is something unmatched except by the amazing development of the automobile industry. The product of each has become an item of paramount importance to the American family, and the possibility of combining the advantages of radio and the automobile has been considered by far-visioned car manufacturers for some time.

In some quarters argument has been advanced that a radio set in an automobile must necessarily act as a distraction to the driver. There has even been some discus-

sion of the possibility of adverse legislation, or at least legislative control of the use of radios in cars. However, *Automotive Industries* (from which much of this material is abstracted), states that it has not learned of any definite move on the part of any group to place legislative limitations on the use of radio in motor cars. The informal argument to the effect that a loud speaker would tend to claim too much of the driver's attention, has been met with the opinion that conversation between the driver of a car and his passengers also

might be termed a distraction, and one which is offset by the presence of the receiving set.

Within the past several weeks Alfred P. Sloan, Jr., president of the General Motors Corp., and Walter P. Chrysler, president and chairman of the Chrysler Corp., have expressed the attitudes of their companies on this subject in no uncertain terms. Mr. Sloan said in part: "Not only do we believe that there is a great opportunity for

the development of the radio business as an adjunct to the automobile, but the radio field in general is one that is closely related to the automobile and electric business, in which General Motors is engaged."

Mr. Sloan's statement said further: "New Cadillac and LaSalle cars have been designed for radio installation and thousands of installations already have been contracted for by dealers. As quickly as possible the same facilities will be available for other makes of General Motors cars."

A survey among major automobile manufacturers just completed by *Automotive Industries* has revealed that in the near future a number of other companies will introduce cars either with radio as optional equipment or with the installation already made for the provision of receiving sets. However, the number of manufacturers who have taken no steps for the installation of radio in their products is probably larger. Several automobile executives stated positively that they could see no indication of sufficient public demand of sufficient strength to warrant any measures for the provision of radios in their cars, at this moment.

For several weeks Transitone automobile receivers, the radio receiving sets manufactured by the Automobile Radio Corp., of New York, have been incorporated as standard equipment on Dodge Brothers Senior Six models and on Dodge Brothers motor coaches. More recently Walter Chrysler announced

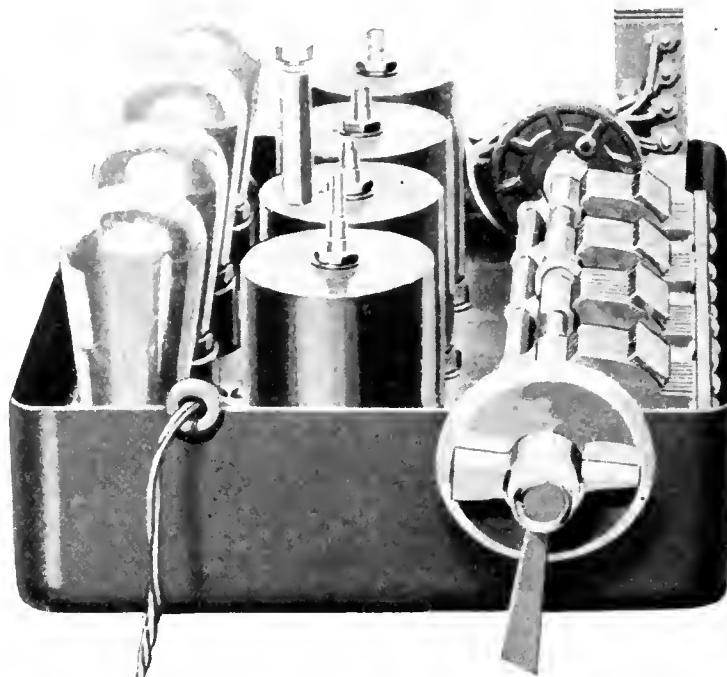

Interior view of the tuning unit of a Transitone automobile radio receiver.

that the closed models of the Chrysler "70" and "77" lines were being wired for the installation of radio receiving sets at the owner's option. Mr. Chrysler's statement said in part:

"After exhaustive tests on the road and in the laboratory by engineers of the Chrysler Corp., the Transitone radio was found to provide perfect reception under all conditions imposed by motor car installation. Its inclusion as an engineered unit in Chrysler cars was immediately directed."

The Transitone is a six-tube set built integral with the car so that only the tuning dial and switch are visible on the instrument board. The antenna is concealed in the top of the body, the lead-in wire running through the right windshield post. The entire set is composed of four units: loud speaker, receiver, audio-frequency amplifier, and batteries. These, with the exception of the batteries, are enclosed in metal boxes, held in place by heavy steel brackets under the cowl.

Type of Circuit Used

The receiver has three stages of tuned-radio-frequency amplification, a detector, and two stages of transformer-coupled audio-frequency amplification. Three 201A-type tubes are used in the radio-frequency sockets; one 112A-type tube in the detector socket; one 201A-type tube in the first

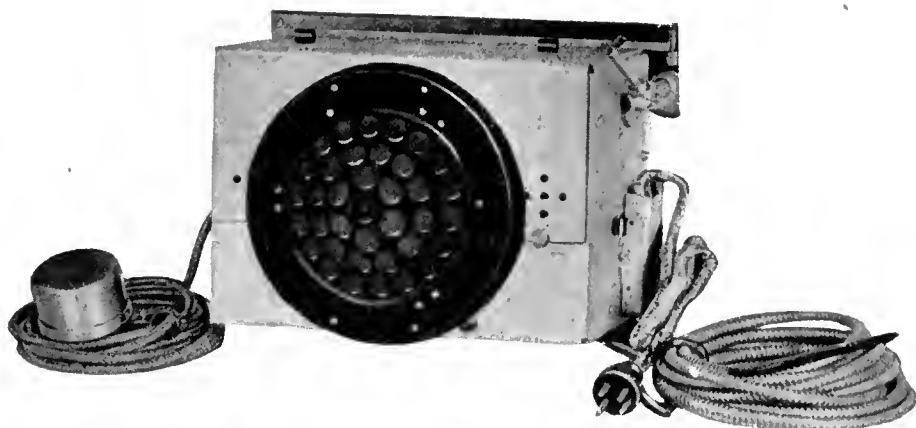

The complete chassis of the Bosch automobile radio.

and an automatic volume control, so that the driver does not have to readjust his volume control each time he passes behind a steel building or under overhead wires. A volume control knob is provided to allow the driver to set the volume to the desired level where the automatic control holds it as long as the station signal strength does not become too weak.

The set uses two stages of screen-grid radio-frequency amplification, a power detector, and two stages of resistance-coupled

wires strung lengthwise between the outer covering of the car top and the upholstering inside the top. The lead-in wire connecting the antenna to the set is covered with a copper braid to prevent it picking up spark noise.

The Bosch Motor Car Set

The American Bosch Magneto Corporation announced and displayed the Bosch Motor Car Radio for the first time during the New York Automobile Show. The receiver utilizes screen-grid tubes and is thoroughly shielded from outside interferences and from the electrical system of the automobile. The receiver and the cone-type electromagnetic loud speaker are contained in one small compact unit which is mounted out of sight on the dash, behind the instrument panel. A solid shaft operates the receiver from the tuning control unit which can be mounted in any convenient position on the dash.

This control unit, no larger than a man's hand, contains a key switch to prevent unauthorized operation in the absence of the owner. One knob controls the tuning and the other controls volume. The station selector dial is electrically lighted and tuning is made easier through the use of the Bosch "Line-O-Lite" dial.

The receiver operates from the storage battery of the car and from dry-cell batteries which are carried in a weather-proof steel container mounted underneath the car. No mutilation of the dash, top, or upholstery is necessary in the installation of Bosch Motor Car Radio. The antenna is not located in the roof of the car but consists instead of a metal plate fastened under the car.

The list price of Bosch Motor Car Radio, complete in every way with tubes, B batteries, shielded wiring, etc., including installation, will be \$140.00. All Bosch distributors and some automotive distributors will handle the receiver.

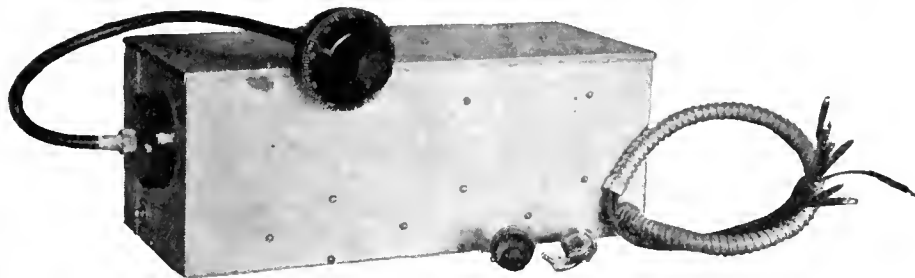

Chassis view of the Delco-Remy automobile radio.

audio-frequency socket, and one 112A-type tube in the last a.f., or power stage. These sockets are cushioned to prevent the transmission of road shocks, and, under normal driving conditions, the tubes are said to last virtually the same length of time as those in a regular set.

To facilitate installation of Transitone equipment at the time of sale, a number of leading motor car manufacturers are building antennas in the roof of their 1930 models at the factory and in other ways specifically designing their products to accommodate radio receivers. Among these are: Chrysler Models 70 and 77, Desoto, Franklin, Gardner, Hupmobile 8's, Jordan Airway Models, Moon, Packard, Peerless 8 Series 3, and Pierce-Arrow. Arrangements have also been concluded whereby the Willard Storage Battery Company's nationwide system of service stations will sell, install, and service Transitone receivers.

The receiving set for automobiles introduced by the Delco-Remy Corp., of Anderson, Ind., and being used in Cadillac and La Salle cars is now being manufactured by the recently organized General Motors Radio Corp., of Dayton, Ohio, which also manufactures the Day-Fan radio receiving sets for home use. The entire manufacturing and engineering work has been transferred from Anderson to Dayton.

Automatic Volume Control

Ease of control is essential because the driver does not have time to adjust several dials and controls while he is driving. The Delco-Remy set has a single dial control

audio-frequency amplification. Three variometers are mounted in line on the same shaft to tune the radio-frequency stages.

The set is mounted between the instrument board and dash to the left of the middle of the car and is out of sight. The tuning dial is connected to the set through a flexible shaft similar to a speedometer drive cable, to prevent any disturbance to the tuning adjustments, which might be caused by a slight weaving of the car. A gear reduction is used at each end of this flexible shaft, in order to give a vernier action on the dial as well as to reduce the effect of twisting the flexible shaft. The set is connected by flexible leads to a terminal box on the loud speaker.

The antenna consists of five parallel

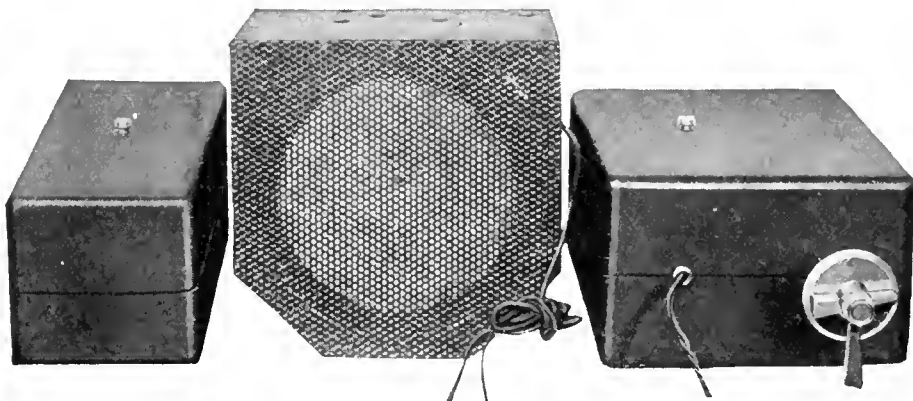

Transitone automobile radio, model RN 109, in the position in which it is installed beneath the cowl.

The MARCH

Reviewing the Commission's Reign
Too Much Politics in Radio Licensing

The Jellyfish Commission

The Federal Radio Commission, after a reign of nearly three years over broadcast allocation, stands nervously before the bar of public opinion. Its only notable action in three years of broadcast regulation was the adoption of General Order 40 and the allocation accompanying it. This action was preceded by a year and a half of purposeless bungling and alibis.

Only the passage of the Davis Amendment forced the Commission from its initial policy of dilly-dallying and compromise, almost uninfluenced by the demands of the listening public. Many acceptable reasons may be advanced to account for the delay in adopting a general plan of allocation, but the principal and only important one was lack of courage to face the issues involved. Improvement, of course, was effected before General Order 40 but, so chaotic were conditions when the Commission started work, that a committee of high school seniors could have brought about improvement.

From the moment of its inception, the Commission was aided by sound engineering advice. Within 30 days of its formation, it had in its hands a complete allocation plan based on thoroughly demonstrated engineering principles. Had it acted promptly, the Commission, aided by the backing of public opinion and, if required, additional power of confiscation through legislative action, could then have accomplished a wholesale reduction in the number of stations. During the first few days of its operations, the owner of every pirating broadcasting station expected hourly announcement of the cancellation of his license. But the Commission feared to test its powers. It sought to do "gradually" what could be done only on a wholesale basis.

Station managements soon discovered the temper of the Commission. It has been yielding to individual pleas ever since, each a further narrowing of service to a specially favored area.

The most important action, as we have stated, taken by the Commission in its long history, was the adoption of General Order 40. But it has failed to stand behind this order with the vigor necessary to insure its success. The value of the regional channels has been almost nullified by power increases and excessive loading so that they are to-day little better than local channels. The invaluable cleared channels, on the other hand, have been occupied very largely by stations of such small power that they should be on regional channels. The few really powerful stations on cleared channels have abundantly proved that their assignment represents the most efficient possible allocation. But allocation to cleared-channel operation has not been considered an obligation to render a rural service. Instead, the wide-spread use of cleared channels for regional service only has been construed as evidence that cleared channels are unnecessary.

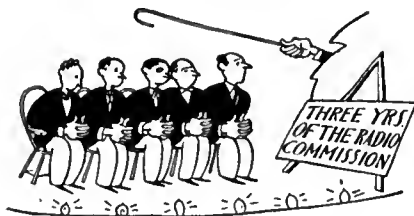

Yieldings to political pressure in behalf of particular stations have become more and more difficult as conditions have become more and more crowded. It has been inevitable, therefore, in absence of firm resistance to compromise of engineering principles, that the standards set up in General Order 40 should be gradually lowered. Regional assignments are supposed to give the stations allocated to them the opportunity to serve the audiences within their high-grade and regional service areas an interference-free signal. There were to be no more than 125 regional stations operating simultaneously, but the number has been progressively and substantially increased. The power assigned to regional stations has, in many instances, been increased beyond the point that permits other stations on the same channel to serve their intended range. For example, WTMJ, worthy of a cleared assignment, if one is available, finds itself operating in the face of WFLA-WSUN, Florida, which pumps a strong signal into its territory, while WLBZ, in Maine, on the same channel, has had a power increase to 500 watts. WJAY, in Ohio, in response to vigorous protest, has recently been shifted to another channel, but now Philadelphia stations are being interfered with by that station. Its new assignment has effectively converted the 610-kilocycle Philadelphia channel from a regional to a local one.

The requirement that 50-kilocycle separation be maintained among stations within the same area now appears slated for abandonment. This essential principle should be rigidly supported, not only to avoid cross-talk trouble on average receivers but also to prevent undue concentration of stations in populous areas. In spite of the clutter of stations operating simultaneously in the New York area, WGSB, apparently through political influence, has secured a so-called "experimental" license for 600 kc., only 30 kilocycles from WMCA and WNYC. It is authorized to use 250 watts at night in total disregard of WCAO, in Baltimore, less than 170 miles away, attempting



to serve that area with Columbia programs.

Perhaps the most reprehensible feature of such jellyfish yielding to political importunities is the fact that most of these arbitrary licenses are secretly granted. Stations which suffer from these disastrous assignments are not notified in advance nor are they given opportunity to present formal evidence showing the effect of such assignments. All one must do, apparently, is gather unto himself a couple of Congressmen, visit the most weak-kneed commissioner available, make a few grand statements about service to the public, and some way, regardless of the general good of the listener, will be found to accommodate the pleading station. Without the political support, however, pleading is of little avail for the very practical reason that the other is hopelessly overcrowded.

With increasing frequency, the Federal Radio Commission is making adjustments and reassignments without notifying affected stations or giving them opportunity to

OF RADIO

The R.C.A. on the Griddle at Washington
Has the R.C.A. a Monopoly of Radio Patents?

have their protests heard in advance of such assignments. The unfortunate wording of the Radio Act makes it practically impossible for stations adversely affected by such political pandering to bring their cases before the Court of Appeals because that privilege is accorded only to those who initiate an application which is denied by the Commission. Most of the peculiar assignments are made without hearing and the listening public, as nearly as it can be represented by stations imposed upon, has no opportunity to make itself heard or to secure review of unwise and arbitrary decisions of the Commission.

We should not be too ready to put all the blame on the present Commissioners. The greatest blame should be attached to those who formed the original Commission. They had the whole situation in their hands with full support and confidence of public and politician alike. But, with crass disregard of the listening public, they adopted the attitude of the broadcast station owner and spent much of their time in discussing his property rights. But the present Commission must take the full blame for permitting the progressive devaluation of the benefits conferred by the adoption of General Order 40 and for its extraordinary failure in grasping, or rather selling, through public education, the merits of allocation based on engineering principles.

"A Patent Pool for Public Service"

The hearings before the Senate Interstate Commerce Committee for the purpose of guiding the destinies of the Couzens Bill have not been particularly helpful to the prestige of the Radio Corporation of America. In fact, every interest not directly affiliated with the RCA in one way or another has taken the opportunity to issue some withering blasts. Newcomb Carlton of the Western Union told the Senators that the British cable-radio threat claim is "one of the most fantastic bogies that has ever been dressed up." He pointed out that the message business across the Atlantic during the past nine months, consisting of 51,100 messages daily, was divided as follows: Western Union 44 per cent.; Commercial I. T. & T. 29 per cent.; French cable 7 per cent.; merger cables 2.9 per cent.; merger beam radio 1.8 per cent.; RCA with the British merger 3.5 per cent.; and RCA with all other European countries except Great Britain, 10.2 per cent. In other words, this allegedly all-consuming merger does less than 5 per cent. of the total business and shares but 3.5 per cent. with RCA.

Joseph Pierson, president of Press Wireless, Inc., before the same committee, described his difficulties in procuring apparatus from the RCA to operate on the channels assigned the newspaper group by the Federal Radio Commission. The newspaper men were asked to pay the base cost of the apparatus charged by the General Electric Company to the Radio Corporation, plus a 45 per cent. profit to the RCA, plus 5

per cent. royalty on gross message business, plus a surrender without any charge to the RCA of all patents held by Press Wireless, plus the requirement that Press Wireless must charge its clients with a view to earning a profit and not as a mutual company, plus a prohibition against using the facilities for anything else but telegraph code work and specifically not for transmission or reception of facsimile pictures and the like. For a benevolent monopoly (if we interpret the high-

sounding phrases of Messrs. Young and Harbord correctly) the RCA is exceedingly jealous of prospective competition.

B. J. Grigsby, president of the Grigsby-Grunow Company, revealed that his company has paid

\$5,302,879.15 in royalties in a year and a half to the Radio Corporation of America for patents which he does not consider worth this amount of royalty. "But the radio combine has so terrorized the industry and so intimidated the jobbers and dealers everywhere that they were afraid to handle what they called 'unlicensed' sets. Our bankers said they would not finance us unless we took out a license." . . . "When the Radio Corporation fixed this royalty of seven and a half per cent., it did so on the pretext that it had a complete monopoly of the radio patent situation and that its patents covered every part of the radio receiving set. This is untrue. We are now paying royalties to three other patent owners and are being sued by five additional companies for infringement of seven patents. In no

case has the Radio Corporation protected us against these patentees or helped us in the suits which have been filed against us."

Mr. Grigsby, like Mr. Pierson, has become impatient with the patent pool "formed at the urgent request of high Government officials." One of the unfortunate features about the RCA license situation is the fact that their royalty rate is such

a burden upon manufacturers that independent inventors have had the greatest difficulty in securing recognition. The RCA, on the other hand, collects huge royalties on patents, many of which have not been adjudicated.

The industry has paid a toll of tens of millions for patent rights to the RCA group. The companies from which the RCA has procured its patent structure have spent substantial sums for research which have been handsomely returned in commercial and manufacturing advantages and, what is more unusual, have also yielded immense royalty returns although only a very minor proportion of these patents have withstood the test of the courts. If radio had not been such a bonanza at the start, its executives would not have been so ready to pay royalties on unadjudicated patents and would have driven a much harder bargain. Under these conditions, many an independent patent, now out in the cold, would now be receiving the recognition intended by the protection of the patent law.—E. H. F.

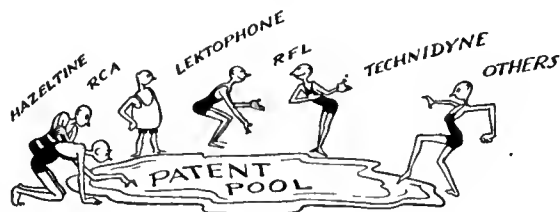



Walter Damrosch und the National Orchestra.

VOLUME CONTROL IN BROADCASTING

Factors Which Limit Range of Volume that Can be Handled by Broadcast Circuits. Effect of Cross-Talk and Repeater Overloading, Frequency Characteristic of Tie-Lines, Limitations Imposed by the Receiver, etc.

By O. B. HANSON

Manager Plant Operation and Engineering
Dept., National Broadcasting Co.

All mechanical and electrical devices have their limitations as man has not yet constructed a machine or a piece of apparatus that is known to be able to operate at 100 per cent. efficiency under all conditions.

In broadcasting less than ten years have been required to develop the present equipment, and the progress which has been made in this direction may be classed as remarkable. The reception enjoyed by radio listeners to-day is in marked contrast to the early days when it was thrilling to receive any signal at all, whatever might be its quality.

Nevertheless, we have *not* yet reached the point of saying, "Well, that's about as good as we can do." Every day we are working, experimenting, discovering, and refining. And each step we take leads to another step. It is probable that the progress has been so gradual that each succeeding stride has not been generally recognized by the average listener.

Pioneers among radio listeners will undoubtedly recall many of the undesirable noises that marked early broadcasting. There was, for instance, a raucous vibrating rattle when volume increased beyond a certain point, and it could not be eliminated by adjustment of the radio receiver. This was the result of faulty production, transmission, or volume control in the studio. To-day we have little of this trouble from properly

constructed and operated equipment, but our improvement has required years of study.

We have learned something of the relation of volume control to other factors, such as size of the broadcast studios and their acoustic properties, "balance" of producing units such as orchestras,

volume range of primary amplifiers, etc. We have learned many of the limitations of the radio transmitter itself, and of the receiving sets in use.

In our study of volume control, we have found important limitations imposed by the avenues over which the signal transmitted reaches the radio receiver—the ether itself and the wire over which the sound must be sent.

There has been established a scale of energy level in order that the limitations in these various stages may be compared

with volume variations of program material being transmitted. The unit of measurement of electrical energy in audio-frequency circuits is the transmission unit, which has recently been christened the "decibel." And the basis to which all levels are compared is known as "zero level." Originally, zero level was established by the telephone companies in the early days of the telephone. It was the level of the average electrical energy developed by the average speaker talking into the ordinary telephone carbon transmitter. This energy level in standard electrical terms is approximately twelve milliwatts. In broadcasting circles, when engineers speak of "zero level" they usually refer to the maximum peaks which are their most serious consideration. These maximum peaks in most cases do not exceed twelve and one half milliwatts.

The instrument used to

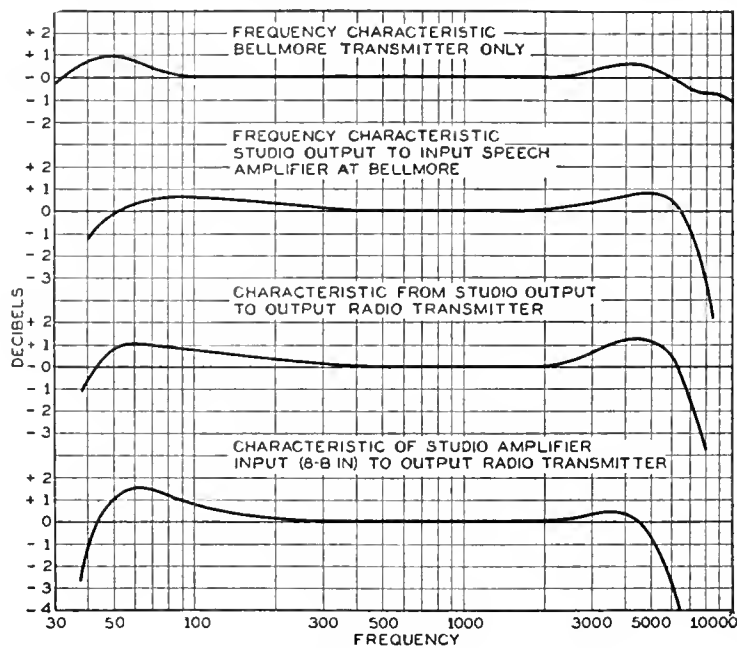

Fig. 1

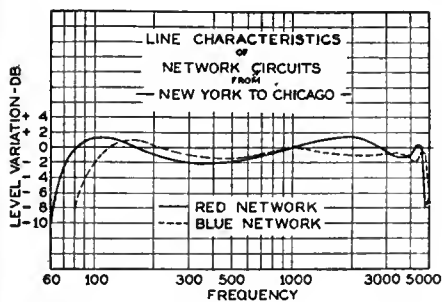

Fig. 2

measure energy level in broadcast equipment is known as the volume indicator, which in reality is a vacuum-tube voltmeter. The scale of the instrument runs from 0 to 60, 30 in the center of the scale being the calibrating point to represent the peak level. This is chosen, of course, to permit the needle to swing freely past this point without hitting the back stop.

There are two major sources which impose limitations on volume variation—the wire lines and the ether. Under the present conditions of broadcasting, with only a limited amount of power permitted, the ether cannot be depended on as a certain medium beyond rather definite limits. Therefore, in nationwide distribution of programs, it becomes necessary to use wires.

Wire Lines in Broadcasting

Telephone lines in the United States are designed primarily for the transmission of speech from city to city. When these existing lines were built there was no thought of transmitting music as it is done to-day. The lines were designed for the transmission of voice only and the quality of the speech was not so important as the intelligibility. It is this transmission system which is used to-day for the transmission of music, and music imposes more stringent requirements for its transmission than does intelligible speech.

To obtain intelligible speech it is only necessary to transmit frequencies between 250 cycles and 2500 cycles, whereas to obtain satisfactory transmission of music it is necessary to transmit frequencies of from 100 to 5000 cycles.

To change a telephone system over to meet these requirements requires considerable engineering and is after all somewhat unsatis-

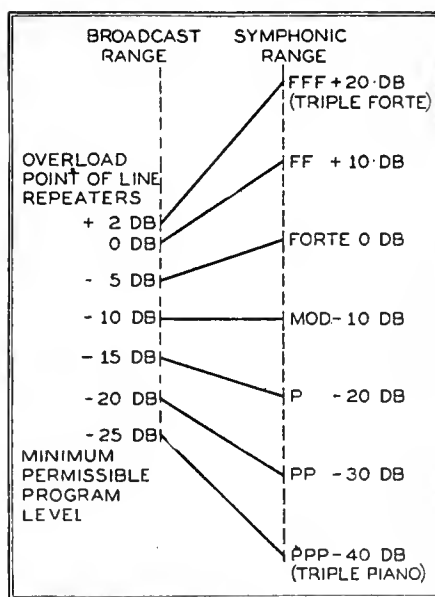

Fig. 3

factory. More repeaters must be introduced, and these amplifiers must have better frequency characteristics than those required in the transmission of ordinary speech.

Music, unlike telephone conversation, varies considerably in its volume. We have the range from triple pianissimos to triple fortes. This variation, when expressed in transmission units, is approximately 60 decibels in the case of a symphony orchestra. The average long telephone circuit

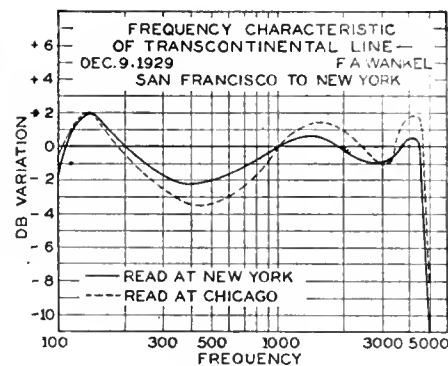

Fig. 4

is not capable of satisfactorily handling such a variation in volume. There is a limitation placed on the maximum energy level which can be transmitted over telephone lines. The maximum safe level is something of the order of plus six decibels and this is imposed primarily by the cross-talk factor.

Cross-Talk Problems

Hundreds of telephone circuits run parallel to each other for many hundreds of miles, and even though these wires are carefully insulated from one another, and transposed in an attempt to reduce the cross-talk effect, the electrical energy being transmitted on one pair will induce small currents to flow in adjacent wires. Everything has been done, of course, to reduce this effect to its economic minimum. The higher the frequency the greater is the possibility of this phenomenon.

The greater the energy in one circuit, the more cross-talk to another circuit, and experience has indicated the maximum permissible level on a telephone circuit to be plus six decibels. This, therefore, is our limitation on the output.

This means that our triple fortes must not be transmitted to the line at a greater level than plus six decibels. We also have our limitation at the bottom of the volume range. The telephone circuit running for miles adjacent to another circuit carrying a program will receive from that circuit by induction a certain energy level of cross-talk. If an amplifier with considerable gain is connected to the end of the dead circuit, cross-talk can be amplified to a point where it is clearly
(Continued on page 292)



The monitor while seated in front of his controls may view activities in the studio through a sound-proof glass window but he listens to the program from a loud speaker.



A glimpse of the monitor in front of his controls from a studio at WEAf.

Some Developments in HIGH-FREQUENCY MEASURING EQUIPMENT

By H. D. OAKLEY

General Electric Company

During the past few years there have been developed systems of telemetering, remote control of apparatus, wire and wireless carrier communication, etc. As these systems come more and more into use their complexity increases and the conditions which the apparatus of a system must satisfy become more exacting. And so it becomes necessary to supplement the design of such apparatus with measurements made on the apparatus itself, not only for the purpose of improving its design but also to determine its performance characteristics before being put into service.

The systems mentioned make use of modulated high-frequency current. Therefore, in order to make measurements on apparatus built for these systems there must be available equipment with which it is possible to generate and control modulated high-frequency current and to fix the characteristics of this current so that they meet the needs of the apparatus upon which measurements are to be made.

There has been developed in the General Engineering Laboratory of the General Electric Company equipment—signal generators, a.f. oscillators, etc.—to provide facilities for this class of measurements. This article, and those that are to follow, will describe this equipment and show its main electrical and operating features. Although the particular apparatus which is the subject of this article generates currents whose frequencies lie in the broadcast band and modulates them with frequencies in the audio-frequency band, still its design is adaptable to other ranges of high frequencies and modulating frequencies. This article describes the signal generator equipment.

The Signal Generator

An inspection of the two pictures on this page of the signal generator will supply one with information concerning its appearance, construction, and arrangement. The signal generator generates a current of a particular high frequency,

The signal generator apparatus described in this article was developed in the laboratories of the General Electric Company. The second article of this series will describe the audio-frequency voltmeter circuits used. These have a range of from about 0.2 volt up to 200 volts. The third installment will describe a voltage attenuator system using mutual inductors.

Additional information on these instruments can be obtained from the Engineering Products Division of the RCA-Victor Corporation of America through whom the apparatus is available.

—THE EDITOR.

modulates it, amplifies it, and delivers it to the output terminals. The signal generator must in addition indicate the absolute value of the frequency of the current it is generating and the degree to which it is modulated.

The circuits and units of the signal generator have been arranged in six groups, and as far as practicable each group has been restricted to the performance of a single function. There are thus six panels and any one of these may be removed for inspection or adjustment without disturbing the other groups. This panel type of construction also provides the additional advantage of making it possible to change units to meet special conditions; for instance, the high-frequency oscillator panel can be removed and replaced by another, enabling the signal generator to cover another band of high frequencies.

The circuit of the r.f. oscillator (Fig. 1) is of the tuned-grid, self-biasing type. The plates of the variable condenser are shaped

so that the frequency of the oscillator changes in proportion to the angle through which the condenser is turned. The scale is marked directly in kilocycles (500-1500) and an additional scale permits reading frequency differences down to 200 cycles. In parallel with the main tuning condenser is a small vernier condenser. This vernier makes it possible to set the frequency of the oscillator so that it agrees with the frequency value marked on the scale. The tuned circuit of the oscillator is inductively coupled to the grid of the modulator tube.

The Modulator

The high-frequency voltage supplied to the grid of the modulator by the oscillator is of constant amplitude. This constant voltage or current is of relatively little use in the systems we are considering. It is necessary to arrange the system so that this r.f. voltage can be modulated. There may be required, for instance, a 500-kc. voltage modulated with 500 cycles. This means that there is required a voltage whose frequency is 500 kilocycles, but the amplitudes of successive cycles instead of being the same value rise and fall about some mean value and go through this series of values 500 times a second.

The modulator is a device which when supplied with a high- and a low-frequency voltage combines them in such a manner that in its output circuit appears the high-frequency voltage modulated by the low. In the signal generator a screen-grid tube is associated with the proper voltages and circuits to make it act as a modulator. The process of modulation in this case is briefly this: The control grid of the tube is supplied by the oscillator with a high-frequency voltage of constant amplitude. So long as the screen-grid voltage is held at some constant value there appears in the output of the modulator a high-frequency, constant-amplitude voltage. Now

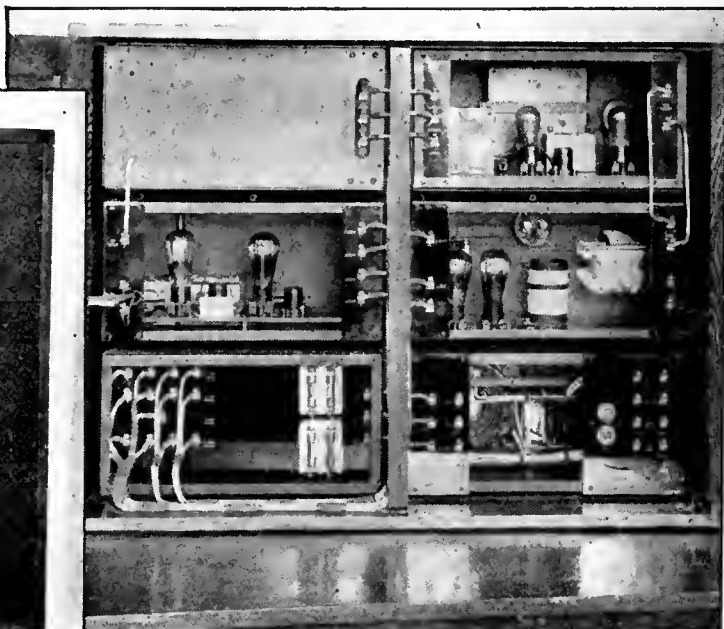
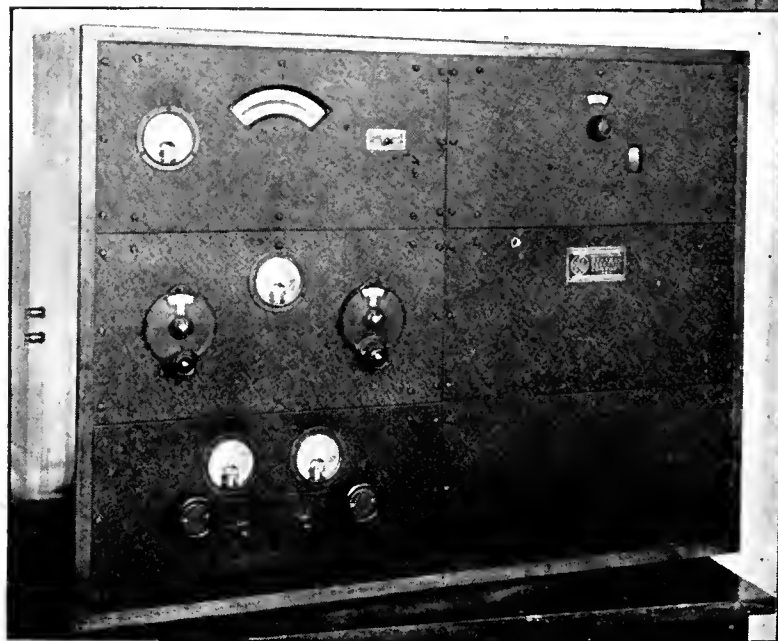

Two views of the signal-generator equipment developed in the laboratories of the General Electric Company.

PART I—

A Description of General Electric Signal Generator Equipment. This Installment Deals with the Design of an Oscillator, Modulator, and Indicator of Depth of Modulation. Subsequent Articles on Associated A.F. Voltmeter and Attenuator.

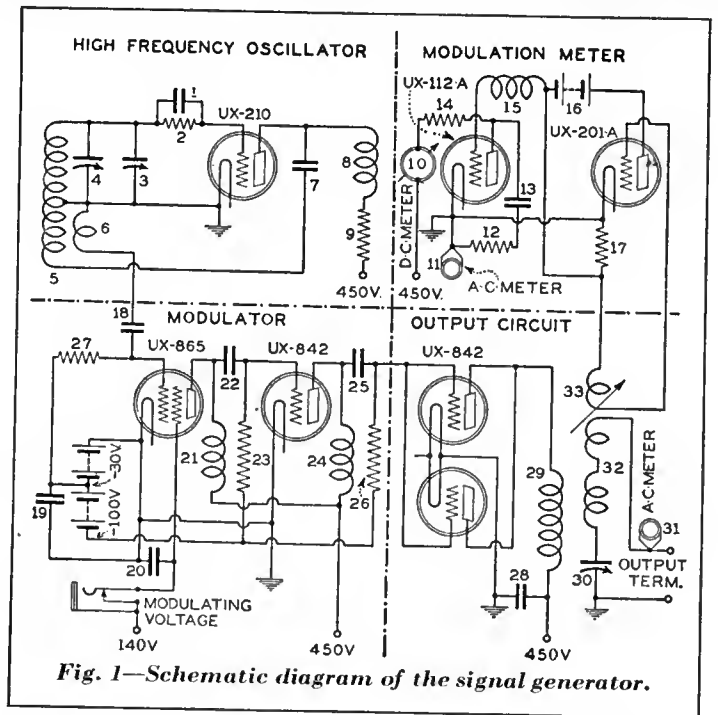

Fig. 1—Schematic diagram of the signal generator.

if the screen-grid voltage be raised and lowered about its original value, the amplitude of the high-frequency voltage in the modulator output will also rise and fall, and thus there will be generated a modulated high-frequency voltage. Therefore, to effect modulation it is merely necessary to supply the screen grid with the proper modulating voltage. This may come from a microphone, a magnetic pick-up unit and phonograph records, or some sort of audio-frequency oscillator. One of the pictures shows a type of audio-frequency oscillator which has been used in some installations for supplying the modulating voltage. This oscillator will generate a voltage of any frequency within the range of from 30 to 10,000 cycles, and the frequency of the voltage generated can be read directly from a scale. The wave shape throughout the entire range is usually good. The output voltage of the modulator excites the grid of a one-tube, resistance-coupled amplifier. This amplifier simply increases the voltage to a value sufficiently large to control the grids of the output tubes.

The Output Circuit

The output circuit consists of a single tuned circuit and milliammeter. The circuit is designed to be used with low-impedance apparatus connected to its output terminals. The meter indicates the amount of current flowing in the circuit. Variable mutual inductance coupling exists between the output circuit and the modulation meter. The coupling between the output circuit and output tubes is inductive and quite loose. The output tubes are connected in parallel and the inductance in their plate circuit is large enough to make them operate as a linear amplifier under all possible conditions of the output circuit.

In making measurements with modulated voltages it is not only necessary that this voltage be generated but also the degree to which it is modulated must be known. The degree of modulation is usually expressed in terms of percentage. For example, if the amplitude of a modulated voltage rises to 110 per cent. and falls to 90

Parts Used in Generator

HIGH-FREQUENCY OSCILLATOR

1. Grid condenser, 0.00025 mfd.
2. Grid leak, 100,000 ohms
3. Frequency correcting condenser, 15 mmfd. maximum
4. Main tuning condenser, 0.0006 mfd. maximum
5. Oscillator inductance, 150 μ h. (approximately)
6. Coupling coil, 4 μ h.
7. Plate by-pass condenser, 0.005 mfd.
8. Plate choke, 60 mh.
9. Plate resistor, 12,000 ohms

MODULATION METER

10. D.C. plate meter scale, 0-10 mA.
11. A.C. plate meter scale, 0-50% modulation (thermocouple heater 700 ohms resistance)
12. Load resistor, 12,000 ohms
13. Condenser, 4 mfd.
14. Plate current limiting resistor, 50,000 ohms
15. Choke, 60 mh.
16. Battery, 22.5 volts
17. Resistor, 100,000 ohms

MODULATOR

18. Coupling condenser, 0.00025 mfd.
19. By-pass condenser, 0.1 mfd.
20. By-pass condenser, 0.00025 mfd.
21. Choke, 60 mh.
22. Coupling condenser, 0.0005 mfd.
23. Resistor, 5300 ohms
24. Choke, 60 mh.
25. Coupling condenser, 0.00025 mfd.
26. Resistor, 12,000 ohms
27. Resistor, 12,000 ohms

OUTPUT CIRCUIT

28. By-pass condenser 0.012 mfd.
29. Primary coil, 900 μ h. (approximately)
30. Tuning condenser, 0.001 mfd. maximum
31. Thermo-ammeter, 0-350 mA.
32. Output circuit coil, 60 mh.
33. Modulation meter coupling coil, 100 μ h.

per cent. of its mean value the voltage is said to be modulated 10 per cent.; and again, if the values were 150 and 50 per cent., the degree of modulation would be 50 per cent. The modulation meter is a device for determining the percentage of modulation of the current flowing in the output circuit of the signal generator.

This meter consists of two main parts, a linear rectifier and an audio-frequency voltmeter. The rectifier is of a type that was devised and used by Dr. A. W. Hull and is strictly linear over its operating range. To understand the action of the modulation meter assume for the present that there is current of constant amplitude flowing in the output circuit of the signal generator. By induction this current produces a constant-amplitude voltage in the grid circuit of the rectifier and this voltage, in turn, causes a current to flow through that resistor which is common to the grid and plate circuits of the rectifier. This is a direct and not an alternating current. The explanation is that although the voltage applied to the rectifier grid is alternating, and because of the rectifying action of the tube, one would expect that the current in the resistor would be pulsating; yet it is not, because connected to the resistor is the grid circuit of another tube which acts as a condenser in shunt with the resistor. This condenser smooths out the current pulses giving rise to a flow of direct rather than pulsating current. The other tube just mentioned is the voltmeter tube of the modulation meter.

An inspection of the circuit diagram (Fig. 1) seems to show that no bias has been provided for the voltmeter tube but actually there is a bias resulting from the flow of the direct current through the resistor. It is evident that the value of this bias can be controlled by varying the voltage supplied to the grid of the rectifier. This can be effected either by varying the coupling to the output circuit of the signal generator or by varying the current flowing in the output circuit. There then exists means by which it is always possible to set the bias to a predetermined value provided there is cur-

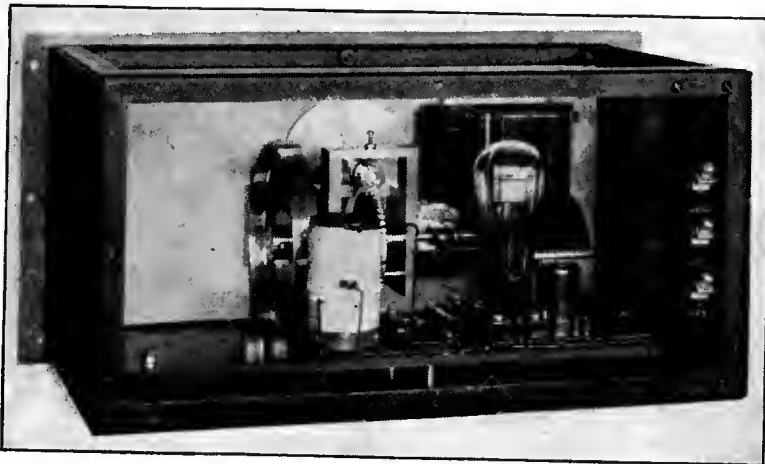

Rear view of the high-frequency oscillator panel.

rent flowing in the output circuit. Should there be no current there would be no bias and ordinarily the plate current of the voltmeter tube would rise to an excessive value, but in this case the current is limited to a safe value by the resistor in the plate circuit.

When a measurement of percentage modulation is to be made the operator adjusts the coupling of the modulation meter until the needle of the d.c. meter (which is in the plate circuit of the voltmeter tube) rests on a predetermined scale division. After this operation has been performed the following conditions exist. The values of the voltmeter plate current, grid bias, and the high-frequency voltage across the grid of the rectifier have the same values as they did have at the time the modulation meter was calibrated. Also the values of grid bias, plate current, and plate circuit resistance are such that the tube will operate as a linear audio-frequency amplifier. The external plate circuit is made up of two parallel branches. One consists of a d.c. milliammeter and a resistance; the other of a condenser, a resistance, and the heater of a thermocouple. The first carries the d.c. plate current of the tube. Should there be set up in the grid circuit of this tube an audio-frequency voltage, there would appear in the plate circuit a corresponding alternating current, and nearly all of this current would flow through the second circuit rather than through the first. The magnitude of this current could be determined from the indication of the thermocouple microammeter.

So far the following conditions have been assumed: A constant amplitude current in the output circuit, the coupling between this circuit and the modulation meter set so that a predetermined set of conditions exist, and the voltmeter tube operating as a linear audio-frequency amplifier. Let all the conditions remain unchanged except the first. Instead of a constant-amplitude current assume a modulated one. Now the conditions in the grid circuit of the voltmeter tube have changed. The grid-bias voltage is still the same but in addition there is an audio-frequency voltage whose frequency is the same as that which is modulating the output current. The magnitude of this voltage is dependent upon the degree of modulation of the output current; the higher the degree of modulation the greater the amplitude of this voltage. Obviously there will be in the plate circuit an alternating current whose frequency is the same as the modulating frequency and whose ampli-

tude is dependent upon the degree of modulation of the output current. Therefore, the indications of the thermocouple microammeter can be interpreted in terms of percentage of modulation of the signal-generator output current. There is one more requirement that the voltmeter must meet. Since the modulating frequency may have any value in the range

potential of the filament generator is 7.5 volts and that of the plate generator 450 volts. The currents from both generators pass through filters which suppress the commutator ripple. The controls and indicators for the motor generator are on the power panel. There are a field rheostat and a voltmeter for each generator, a line switch for starting and stopping the motor, and a pilot lamp which, when lighted, indicates that the motor is connected to the line. There is another switch which in one position connects the filaments and plates of the signal-generator tubes to the power supply and in the other position disconnects the tubes but still supplies power to any auxiliary apparatus which may be connected to the power panel. Behind the panel are located the motor line fuses and a safety switch. When the rear doors of the cabinet are open the safety switch opens the field of the high-voltage generator and so it is impossible to get at the signal generator circuits while the high-voltage circuits are alive.

The distribution panel receives power from the power panel and distributes it to the four panels of the signal generator proper. In the distribution panel are a voltage-dividing resistor and by-pass condensers, and the filament and high-voltage fuses. From the voltage divider are obtained the plate and the modulator screen-grid voltages.

Calibrations

Three calibrations are required: the scale of the high-frequency oscillator, the modulation characteristic, and the modulation meter scale.

In calibrating the high-frequency oscillator scale the dial is turned until the 1500-kilocycle mark appears. The frequency generated by the oscillator is beaten against the fifteenth harmonic of a 100-kilocycle crystal oscillator. If there is a beat note the vernier condenser of the oscillator is adjusted until zero beat is obtained. The oscillator scale reading and frequency then agree. The dial is then set on 1400, 1300, 1200 kilocycles, and so on and at each setting a beat is obtained between the oscillator frequency and the corresponding crystal harmonic frequency. The beat is brought to zero by turning the dial of the oscillator. The amount that the oscillator frequency differs from the scale readings can then be immediately determined. For instance, suppose a zero beat is obtained between the tenth harmonic of the crystal and the oscillator and say the oscillator dial scale read 1002 kilocycles.

(Continued on page 300)

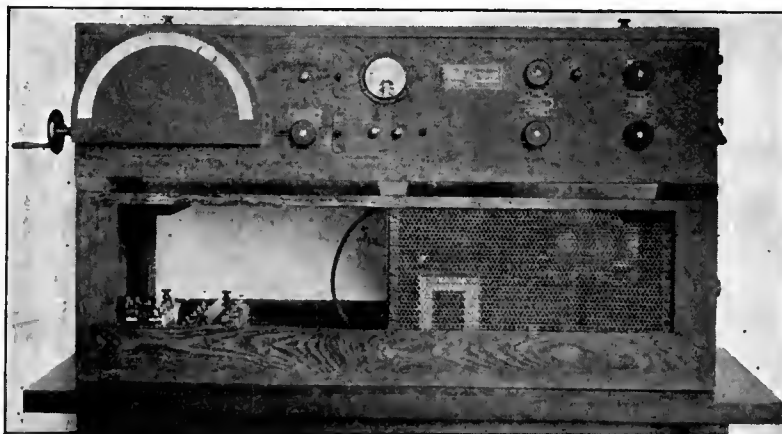

The audio-frequency oscillator for generating modulating voltage.

of from 30 to 10,000 cycles, the ratio between the a.c. voltage across the grid of the tube and the alternating current flowing through the thermocouple must remain unchanged throughout this range of frequencies; otherwise percentage modulation determinations will be in error.

Table I

Variations between the high-frequency oscillator scale readings and the generated frequencies are indicated in the figures below.

Scale Reading Kilocycles	Oscillator Frequency Kilocycles
500	501.0
600	611.6
700	714.2
800	812.4
900	908.6
1000	1004.2
1100	1103.6
1200	1202.0
1300	1299.0
1400	1393.5
1500	1500.0

The Power Panel

The filaments and plates of the tubes of the signal generator are supplied with power by a three-unit motor generator. The motor is a single-phase, 110-volt, 60-cycle induction type. It possesses the desirable feature of running at constant speed over quite a range of line voltage fluctuations and so the generated d.c. voltages are remarkably free from variations due to line-voltage fluctuations. The

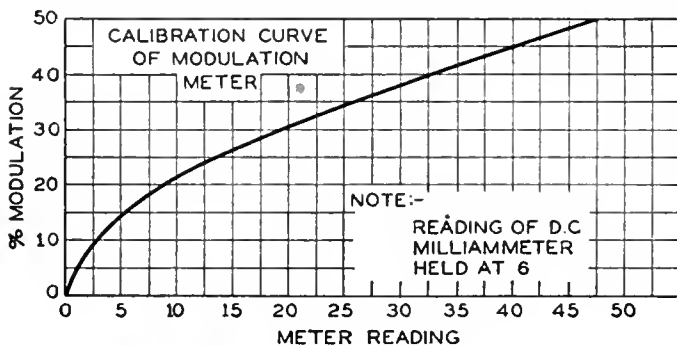

Fig. 3—Modulation meter calibration curve.

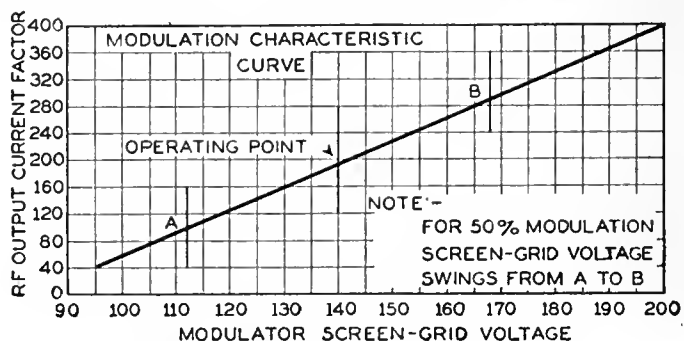

Fig. 2—Modulation characteristic curve.

MAGNETIC CIRCUIT DESIGN

By E. A. UEHLING

Theory and Practical Design of Magnetic Circuits; Air-Gap Flux Density as a Function of the Length and Area of the Magnet; Factors Influencing the Choice of Magnetic Material.

Magnetic fields of high concentration are of importance in many instruments and machines in which energy of one form is converted into that of another form. Among the most important of such instruments in radio engineering is the electromagnetic and the electrodynamic loud speaker. The magnetic fields in the air gaps of these instruments are spoken of as having a high concentration because the flux density in these fields is usually of the order of the magnetic saturation point of the highest flux-carrying-capacity material known. Such densities are in the neighborhood of 10,000 to 20,000 lines per square centimeter. Magnetic fields of this character are not always easily obtained, and when they are obtained it is not always with the greatest economy. It will be of great value to consider the properties of such circuits, and to discuss empirical formulas that greatly simplify the design of many types of magnetic structures. First of all we will consider magnetic circuits in their more general aspects.

Analogous to Electricity

Magnetic circuits are closely analogous to the more familiar electrical circuits, and many of the principles of electrical circuits can be used in the design of magnetic structures. There are, however, many important differences, and it is these variations in the behavior of electricity and of magnetism that is quite largely responsible for the surprising results that engineers sometimes have when testing a carefully designed structure. Among the most

important of the differences in the properties of electricity and of magnetism, and the properties which are responsible for the more or less general belief in the elusiveness of much of the subject of magnetism are: (1) The static nature of magnetism as compared with electricity; (2) The smaller differences in the permeability of various media which accounts for the difficulty of insulating magnetic flux and of causing it to flow in definite paths; and (3) The distributive nature of the motivating force; i.e., of the magneto-motive force.

These conceptions will become evident as we proceed with the discussion of actual design formulas, and they need not be discussed further. Much that we shall say regarding magnetic circuits can be attributed to electromagnetic and permanent-magnetic structures equally well, for there is essentially no difference in the two types of magnetism.

The Fundamental Formula

Corresponding to the Ohm's Law of electrical circuits there exists a relationship of a similar nature between the magneto-motive force of the circuit, the reluctance, and the magnetic flux. The magneto-motive force is expressed in *Gilberts*, the unit of which is defined as the force required to force one line of magnetic flux through a reluctance of one Oersted. The *Oersted*, which is the unit of reluctance, is defined as the reluctance to magnetic flux that is offered by a centimeter cube in air. The reluctance of an air-gap may then be expressed as the ratio of the air-gap length in centimeters to its area in square centimeters. If the magnetic structure to be designed is of the electromagnetic type, the required magneto-motive force necessary in the electrical circuit will be given by the relation

$$MMF = R\phi$$

where the available magneto-motive force is

$$MMF = 0.4\pi NI$$

and, where R is the reluctance of the air-gap computed as already shown, and ϕ is the total flux desired in the air-gap. Then

$$NI = \frac{R\phi}{0.4\pi} = \frac{L\phi}{0.4\pi A} = \frac{LB}{0.4\pi}$$

L being the length of the path and B the flux density

With this relation ends practically all that can be borrowed directly from our knowledge of the analogous electrical circuit. From this point magnetic circuits must be designed as such, and our failure to do so is largely responsible for many strange results obtained in the laboratory.



The distinct nature of magnetism becomes more obvious when we consider that in the magnetic flux as such no energy exists. A magneto-motive force may be required to hold an established condition of magnetism, but once established no further energy is given to the magnetic circuit. Energy is given, of course, to the electrical circuit, the coil of the electromagnet by which the magnetic field is maintained, but all of this energy is dissipated in the form of heat in the winding itself. Once this conception becomes established much of the apparent difference between electromagnetic and permanent magnetic structures disappears.

Permanent Magnetic Circuits

For purpose of design it is of considerable importance to consider magnetic circuits that depend upon a permanent magnet for the maintenance of the magnetic condition. Such circuits have a very great importance in nearly all of the various types of electromagnetic loud speakers. They have not yet become important in the electrodynamic loud speaker where an electromagnet is usually used to supply the required magneto-motive force. However, many laboratory models of the electrodynamic loud speaker with permanent magnets have been made. Experiments of this nature have been in progress for some time, with what might seem to be encouraging results, in view of the rather difficult problem involved. Before discussing this subject, however, it will be necessary to discuss the formulas relating the magnetic circuit with the flux that

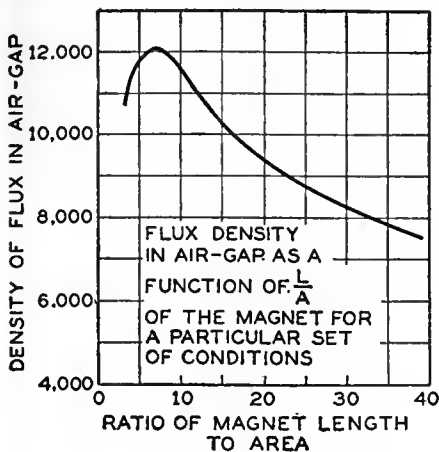

Fig. 1

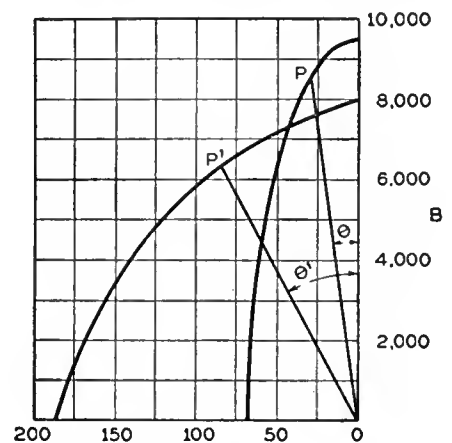

Fig. 2

can be obtained from a given permanent magnet.

In designing magnetic circuits using a permanent magnet to supply the magneto-motive force, the reluctance in the permanent magnet must be considered as well as that of the air-gap. This reluctance is, however, unknown, and the design formula desired should not contain reluctance as a factor in the equation. Such a formula is easily developed. We will assume a well-designed magnetic circuit of negligible leakage flux, and attempt to allow for leakage flux when it exists in another manner. We have the preliminary relation—

$$\frac{MMF}{R} = \phi$$

where MMF is that part of the total magneto-motive force used to force the total flux through the air-gap, R is the reluctance of the air-gap alone, and ϕ is the total flux in the magnet and in the air-gap. If B is the flux density in the permanent magnet, and A' is the area of the magnet cross-section—

$$\frac{MMF}{R} = BA'$$

But R is equal to L/A, the length of the air-gap in centimeters divided by the area of the air-gap in square centimeters. Making this substitution, and dividing by L', the mean length of the permanent magnet in centimeters, and finally, representing MMF/L' by MMF', the magneto-motive force of the permanent magnet in Gilberts per centimeter length available at the air-gap is—

$$\frac{MMF'}{B} = \frac{A'L}{AL'}$$

The B-H Curve

The left side of this equation requires interpretation before the equation can be used in a practical design problem. It can be interpreted in terms of the B-H curve of the material of the magnet, giving a very convenient and practical relationship between quantities the values of which are easily ascertained. A typical B-H curve for tungsten steel is shown in Fig. 3. This portion of the entire B-H curve is all that is used when considering the properties of permanent magnets. The coercive force of the material of the permanent magnet multiplied by the length of the magnet represents the total magneto-motive force in the circuit.

If no demagnetizing force exists in the magnetic circuit, the value of the flux density is given by the highest point of the curve of Fig. 3, which is the retentivity value. If demagnetizing force exists, as, for example, the demagnetizing force or counter magneto-motive force of an air-gap, the flux density in the magnet will be less than the retentivity value, and is determined when the value of the right-hand side of the above equation is determined. We can consider this value of the flux density as the operating point, P and draw a line from it to the origin making an angle θ with the vertical through the origin. Drawing another line through the operating point perpendicular to the line of coercivity we divide the coercivity per centimeter length of the magnet in two parts. The interval between this vertical line and the origin represents the magneto-motive force per unit length of the magnet used in overcoming all demagnetizing forces in the circuit, as, for example, that of the air-gap, and that of the free poles of the magnet. The interval between the vertical line and the coercivity value for the material represents the magneto-motive force per unit length used in overcoming the reluctance of the material of the magnet. Only the former value enters into the above design equation. It

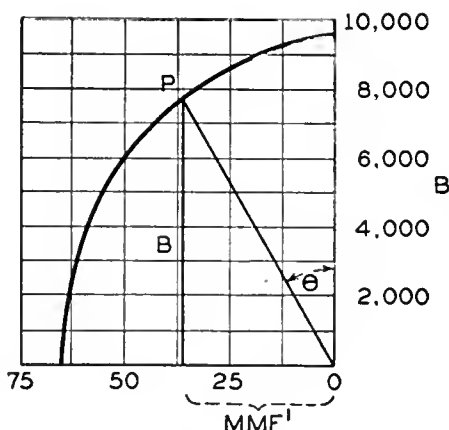

Fig. 3

is the term MMF' given in this equation, provided the magnet is long enough so that the demagnetizing effect of the poles of the magnet is negligible, which is usually the case. The other factor, B, of the left

Table I

TABULATION OF DATA IN DESIGN OF A PERMANENT MAGNET*

(Volume of magnet—357 cm ³)					
A _m	L _m	tanθ	B _m	φ	B _a
3.225	110.6	.001554	8300	26,800	7530
4.031	88.5	.002193	8000	32,300	9075
4.838	73.8	.003152	7600	36,800	10340
5.645	63.3	.004285	7100	40,100	10940
6.450	55.3	.005615	6500	41,900	11770
7.256	49.2	.007095	5900	42,800	12030
7.655	46.6	.007900	5600	42,850	12050
8.062	44.3	.008765	5250	42,350	11900
8.869	40.3	.010585	4600	40,800	11480
9.675	36.9	.012620	4000	38,700	10870
10.482	34.0	.014820	3600	37,700	10580

*Chrome Steel Magnet
Air-gap Dimensions—(3.56 cm.² x 172 cm.)

side of the above equation is the ordinate to the operating point of the B-H curve. Then—

$$\frac{MMF'}{B} = \tan \theta$$

and accordingly

$$\tan \theta = \frac{A'L}{AL'}$$

In other words, the product of the air-gap length and the area of the cross-section of the permanent magnet, divided by the product of the area of the air-gap and the length of the permanent magnet, is equal to the tangent of the angle between a line drawn from the origin to the operating point and the vertical through the origin. This is a very useful equation, and one that greatly simplifies the problem of de-

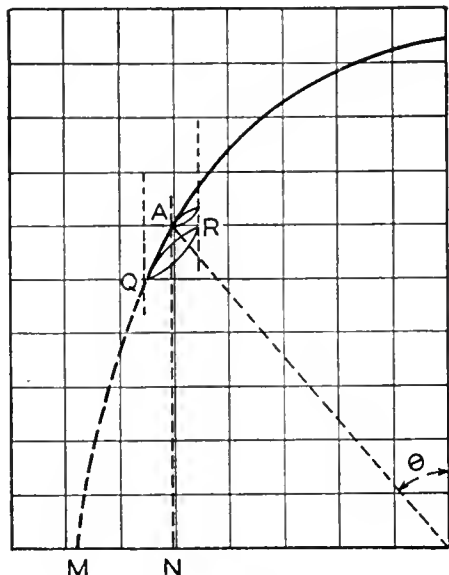

Fig. 4

signing a permanent magnet to supply the required flux density in a given air-gap.

Air-Gap Determinations

The nature of the air-gap is determined, of course, from other considerations. In the electrodynamic loud speaker, for example, it is determined by the size and type of voice coil used. Having the air-gap completely determined, two of the factors of the design equation are determined. A third factor, the area of the steel, may be given a definite convenient value as a preliminary trial in the calculations. This value of the area of the steel together with the value of the desired flux in the air-gap determines a fourth quantity in the equation, the tangent of the angle θ , provided that the leakage flux is small. The fifth and last quantity of the equation, the required length of the magnet, is then determined.

A permanent magnet satisfying all the requirements of the air-gap has then been determined, but the magnet may not and generally will not be the most economical possible. It is obvious that for a given air-gap, an optimum ratio of the area of the magnet steel to the magnet length exists, for an increase in this ratio without limit would only increase $\tan \theta$ without limit, and reduce the flux density in the steel to a negligible value. Consequently the area of the magnet cross-section is not completely arbitrary, and should not be given any one of the many possible convenient values.

The Complete Determination

A convenient method of making the complete determination and the one used by the author for some time is as follows: Determine from considerations of cost and the reasonable limits of weight and size the total volume of steel to be used in the magnet. Then tabulate for successive values of magnet cross-section the corresponding values of magnet length, and continue this tabulation using the design equation given above to include corresponding values for $\tan \theta$, the flux density in the magnet, the total flux, and finally, the flux density in the air-gap. The length and cross-section corresponding to the maximum flux density in the air-gap is that of the most economical magnet. A typical tabulation of this kind is shown in Table I and as a curve in Fig. 1. If the maximum value of the flux density in the air-gap found in this way is larger than required, a smaller value for the volume of steel in the magnet should be chosen, and all the values retabulated. If this value of flux density is less than that required a greater volume of steel will have to be used.

The reluctance of the soft iron parts in the circuit may not always be neglected. Another reluctance that is often of importance is that of the partially saturated soft iron parts in the neighborhood of the air-gap. These reluctances may be taken into account by assigning to them an equivalent air-gap length, determined from the dimensions of the soft iron parts and the estimated permeability at the flux density at which these parts will be used.

Magnetic Materials

The three principal materials of which permanent magnets are made are chromium magnet steel, tungsten steel, and cobalt steel. The latter can be obtained in several different percentages of cobalt alloyed with chromium, and in castings or forgings, each type having magnetic properties different than the others. The B-H curves for each of these materials are necessary to facilitate any determination of the best possible magnet to satisfy a

(Continued on page 282)

RADIO GALVANOMETERS

Probably the most easily constructed form of sensitive galvanometer is that in which the magnet is suspended by a fiber removed from a silk thread. A rather long pointer of very fine wire is attached to the magnet and at right angles to it. The coil is in two sections, as shown in Fig. 1, to provide space for

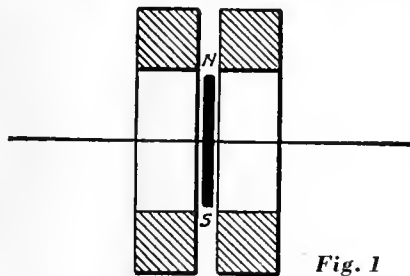

Fig. 1

the suspension fiber. Another form of makeshift galvanometer may be contrived by using a high-resistance coil, such as one half of the secondary winding of a Ford spark coil, and suspending the magnet therein by means of a fine wire yoke, as shown in Fig. 2. In either case, the whole must be inclosed in a glass container, such as a Mason fruit jar or lamp chimney.

Such galvanometers are not satisfactory for radio work as they are disturbed by the slightest jar, and when used, considerable time must elapse before the needle comes to rest. For general purposes, therefore, it is more practicable to support the magnet on a pivot, as in a pocket compass.

A Practical Instrument

A satisfactory magnet may be constructed from two pieces of bicycle spoke three fourths of an inch long, which have been heated to a bright red and plunged into water. Across the center of these a small brass block is neatly soldered, as indicated in Fig. 3. Take the end of a sixteenth-inch drill and make a small center punch with a sixty-degree point. With this, the bearing may be formed in the brass block. The depression should be about $\frac{1}{16}$ " deep, in order to prevent the magnet from being jarred off the pivot. The magnet is now placed on the point of a sewing needle and carefully balanced, by grinding off the heavier end.

The pointer should be of very fine wire, No. 40 nichrome, preferably, as

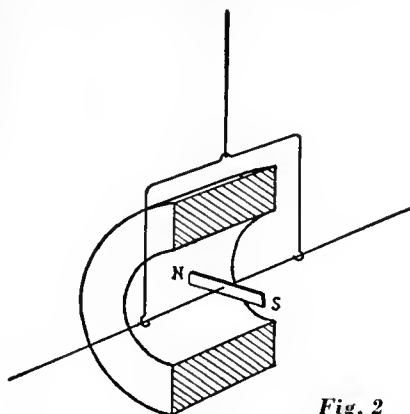

Fig. 2

it is quite stiff. Care must also be taken to have it quite straight, after which it is soldered to the brass block with the merest speck of solder, applied by using the end of a piece of tinned copper wire as a soldering iron.

The supporting pivot is soldered to a piece of No. 30 soft sheet brass, shaped as shown in Fig. 4. This form readily permits of adjusting the plate so that it may be snugly pushed into the inside of the bobbin on which the coil is wound. The sewing needle to be used as a pivot should be let down into a block of wood, with the end projecting just enough to permit the magnet to swing clear with a safe amount of space above the small brass block. This clearance on top need not be more than about a hundredth of an inch, otherwise the magnet might slip off the pivot if the instrument were turned upside down. After soldering, the lower portion of the sewing needle is to be cut off and ground flush with the bottom of the brass plate. Two brass pins are now to be soldered, heads down, to the plate to limit the swing of the needle to 90°. Without these, any excess of current would cause a violent deflection, throwing the delicate indicating

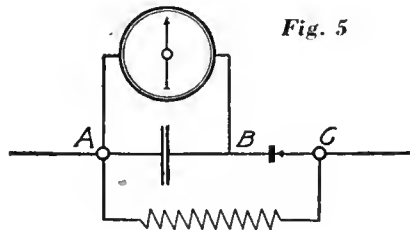

Fig. 5

pointer against the coil and probably bending it.

Mounting the Instrument

Such a galvanometer was built in one of those cases in which the works of a watch are received by the jeweler. The upper rim was removable, and contained a plain glass top. The magnet was about three quarters of an inch long, and was made and supported in the manner just set forth. The coil was wound on a brass bobbin, made by neatly forming a thin brass rectangular tube, just large enough to accommodate the magnet, and soldering two rather heavy end plates to it. The latter, of course, each had a suitable rectangular opening just large enough to slip over the ends of the tube. After lining the bobbin with paper, it was filled with No. 40 enameled wire. (A coil of 6000 ohms resistance makes a fairly sensitive galvanometer.) The end of the wire was soldered directly to the metal bobbin, using a non-corrosive flux, thus avoiding the necessity of bringing out a loose end.

After the magnet and needle have been inserted into the bobbin, the latter may be secured to the bottom of the case by means of a couple of drops of solder, applied with a very small iron. A small block of hardwood or fiber should be fastened in position to support the paper scale. This may be accomplished by the use of two slender

rivets. The metal case forms one terminal, and the other end of the magnet winding is soldered to the end of a brass pin run in through the block that supports this scale. A hole somewhat larger than the pin is made in the metal case, so that it will not make contact with the pin.

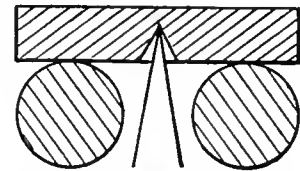

Fig. 3

Such a galvanometer should show a full-scale deflection with the minute current generated by dipping the end of a fine iron wire into a little saliva placed on a dime.

In Fig. 6 is a completed galvanometer and when placed directly in a radio circuit, the instrument should be connected as shown in Fig. 5. Across the galvanometer coil is an 1.5-mfd. fixed condenser. In series with this combination is a crystal of galena to rectify the high-frequency current. R is a non-inductive variable shunt with a range from about 2 to 25 ohms. The introduction into an oscillatory circuit of a galvanometer connected in this manner will add no more resistance than the resistance of the shunt. The small amount of current that finds its way through the crystal rectifier, however, is sufficient to operate a sensitive galvanometer. The large fixed condenser increases the effect on the galvanometer.

The base is simply a wooden box in which the fixed condenser is placed. The upper portion consists of a wooden frame, having a glass top, for which a Kodak plate was used.

The experimenter should have no difficulty in contriving a suitable crystal detector, preferably of the inclosed type. By providing three binding posts, A, B, and C Fig. 5, the instrument may be used as a regular direct-current galvanometer by connecting to posts A and B.

In constructing a shunt for a radio galvanometer it is very necessary that it be non-inductive, variable, and susceptible to measurement. Fig. 7 illustrates one way of providing such a shunt. A strip of hardwood about three fourths of an inch wide is provided, and on this is stretched a length of No. 36 nichrome wire, which has a resistance

(Continued on next page)

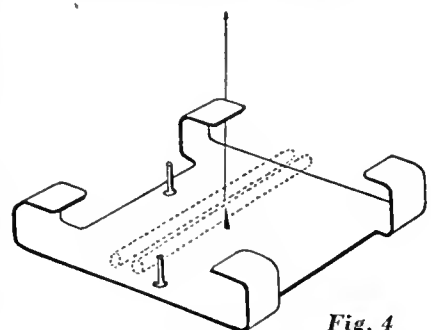

Fig. 4

RADIO GALVANOMETERS

(Continued)

(Continued from preceding page)

of over 25 ohms per foot. Along the underside of this runs a piece of bus-bar wire, so that a small spring clip may be snapped on at any point along the strip in order to connect the resistance wire and the bus wire together at that point. In this manner the resistance is readily varied, and by providing a paper scale, the resistance being used will always be known. The heavy projecting wires, No. 14, are set in suitable holes drilled edgewise through the strip. These serve to make connection with the binding posts of the galvanometer, and are spaced accordingly. In the shunt illustrated, the length was a little over eight inches, and it contained over sixteen ohms.

How to Use the Galvanometer

While a telephone receiver and crystal detector provide a more sensitive method of detecting a minute radio current, it is often desirable to provide some visual indication of the current strength that will not only accurately indicate when the current is at a maximum, but will also enable one to determine the relative value of the current. This feature is particularly important when measuring high-frequency resistance. In a commercial laboratory, the thermo-element galvanometer provides such a means. As such an instrument does not lend itself to amateur construction, a galvanometer such as has been described may be used, and if it has been properly constructed, will be equally, if not more, sensitive.

The action of the galvanometer in this connection may be tested by the experiment as illustrated in Fig. 8. The galvanometer with the crystal rectifier and shunt is placed directly in the oscillatory circuit. As the condenser C approaches the point of resonance, the galvanometer will indicate the fact, even when the shunt resistance is reduced to a few ohms.

What actually goes on in the circuit is as follows. When the condenser of the circuit under test is adjusted so that the circuit is roughly in tune with the buzzer-driven oscillatory circuit, current at the frequency of the driver will flow in the test circuit. This radio-frequency current flows through the crystal detector in series with the condenser across the galvanometer. If the condenser is sufficiently large to offer little reactance to the radio-frequency current, the galvanometer will have no effect upon the a.c. current flowing. This radio-frequency current will be rectified by the crystal detector. In this process a direct current will be produced which will flow through the galvanometer and its shunt resistance.

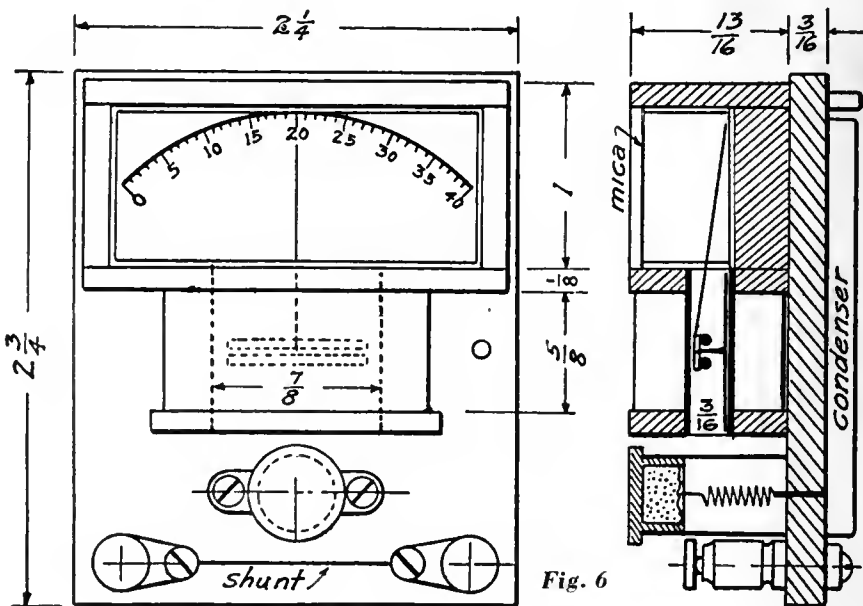

Fig. 6

If the proper position of the two circuits with respect to each other is determined so that the galvanometer needle will not go off scale at resonance, a resonance curve can be plotted

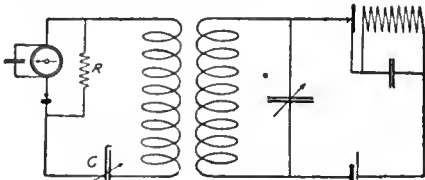

Fig. 8

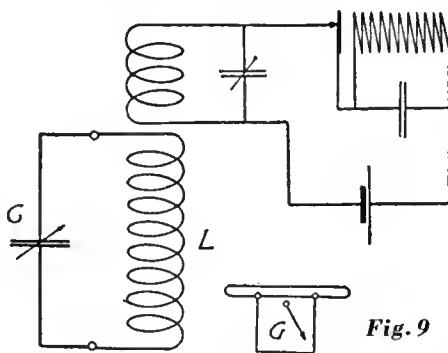

Fig. 9

by noting the deflection at each degree setting of the tuning condenser.

It will be observed that when the distance between the primary and secondary circuits is increased, the point of resonance is more sharply defined, and if the coupling is made sufficiently loose, the point of deflection can only be maintained by the most careful manipulation of a sensitive vernier condenser.

It will also be noted that if additional

resistance is added to the circuit, and the resistance of the shunt R is increased to bring the deflections up again, the point of resonance is not so sharply defined, thus verifying the important fact that in a radio circuit the resistance should be kept as low as possible if selectivity is desired.

The detector circuit in Fig. 8 embraces all the elements of a good wavemeter, assuming that the coil is of low resistance (say 1 layer of No. 18 d.c.c.) and that the galvanometer is sensitive.

The galvanometer may be used as a resonance indicator if it and the crystal are shunted with a single turn of wire about five inches in diameter. In this case the shunt running between the binding posts should be disconnected.

Fig. 9 indicates a method of using a galvanometer in this manner. On one side of the circuit LC is the generator (a buzzer connected to an oscillatory circuit), and on the other is the galvanometer with its single turn of wire.

When measuring the distributed capacity of inductance L, the condenser C is disconnected. As soon as the generator is adjusted to the natural wavelength of the coil, relatively strong radio currents will flow in the latter, and as a result sufficient current will be induced in the turn of wire to deflect the galvanometer after rectification by the detector. The arrangement is very advantageous as it necessitates no connection whatever with the coil, the distributed capacity of which is to be measured.

This method of using a galvanometer also has considerable application in connection with vacuum-tube oscillators. In such cases it is only necessary to bring up the instrument to determine whether the circuit is oscillating. Further use of the galvanometer may be made when the measurement of high-frequency resistance is undertaken.

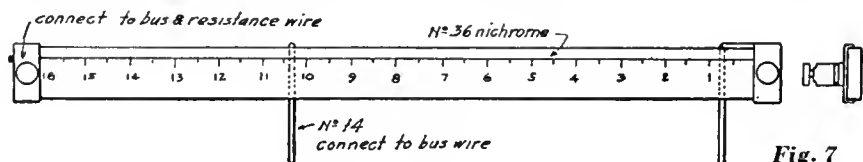

Fig. 7

THE SERVICEMAN'S EQUIPMENT

By J. H. MILLER

Chief Engineer, Jewell Electrical Instrument Co.



Model 409
Set Tester.

Importance of Service Equipment; Details of Two Types of Jewell Radio Set Testers, Models 409 and 199.

The fundamental purpose of any device for testing receivers is to make possible a quick and accurate measurement of the voltages and currents supplied to the various tubes in the receiver. Practically all the important circuits in a receiver finally end at the terminals of the various tube sockets; accordingly if measurements are made at the tube socket terminals of all

but attention should also be paid to the speed with which tests may be conducted. A set analyzer with four instruments, such as the Jewell model 409, is more rapid in operation than the Jewell Model 199 which utilizes only two instruments.

The two additional meters on the Model 409 are available for continuous reading of plate voltage and plate current, an obvious advantage since these two quantities can be noted at any time during the test. By using all four meters simultaneous readings can be taken of filament or heater voltage, grid voltage, plate voltage, and plate current. The adapter plugs supplied with the instrument have five prongs so that measurements may be made on tubes which have their cathodes biased with respect to the filament. Four-prong adapters are also supplied so that measurements may be made on all types of four-prong tubes.

In these Jewell set analyzers all of the instrument terminals are also brought out to separate binding posts so that the instruments may be used separately to make other measurements. For example, if the maximum voltage from the B supply is to be determined two leads can be run from the B-power unit to the two binding posts that connect to the high-range voltmeter, and, by pressing the appropriate push

button, the maximum B voltage may be measured. Having the various instruments available at separate binding posts also makes it possible to make measurements to determine the value of resistors,



Model 199
Set Tester.



Model 210
Tube Tester.

the voltages and currents it is not difficult to determine in what circuits defects exist. If when checking any particular socket a defect is indicated, a good tube can be substituted and if the defect disappears the fault was obviously due to a bad tube, whereas if the defect remains some circuit in the receiver is evidently at fault.

Good instruments for servicing radio receivers are made by a number of manufacturers who have spent considerable time and effort to make such equipment complete, accurate, and rapid in operation. In selecting service equipment the cost is, of course, a factor

condensers, etc. Proper testing apparatus is obviously essential in the servicing of radio receivers and any serviceman who knows something about the circuits of sets can double his efficiency with the proper kind of servicing equipment.

If records are kept of all of the readings on an analysis chart of the type illustrated, the logic of the method cannot be questioned. If a carbon copy of the analysis is left with the set owner, it is just as much of a receipt as a prescription which the physician leaves, if only for sugar-coated pills. And, in the long run, the service (Continued on page 297)

RADIO SET ANALYSIS													
OWNER		READINGS, PLUG IN SOCKET OF SET										DATE	
Mr. A. B. Smith												July 3, 1929	
ADDRESS												Chicago, Illinois	
NAME OF SET												Atwater-Hentz, Model 55A C.	
TUBE NO. IN ORDER	TYPE OF TUBE	POSITION OF TUBE 1ST R.F. DET., ETC.	TUBE OUT				TUBE IN TESTER						
			A VOLTS	B VOLTS	A VOLTS	B VOLTS	C VOLTS (CONTROL GRID)	CATHODE - HEATER VOLTS	NORMAL PLATE M. A.	PLATE M. A. GRID	PLATE CHANGE M. A.	SCREEN GRID VOLTS	
1	224 1st R.F.		2.15	182	2.1	140	3	-3	2.6	5.6	3	76	
2	224 2nd R.F.		2.15	182	2.1	140	3	-3	2.6	5.6	3	76	
3	227 Det.		2.15	94	2.1	82	14	-14	1	-	-	-	
4	227 1st Aud.		2.15	140	2.1	90	3	-3	2.1	3	8		
5	245 2nd Aud.		2.4	228	2.45	205	38		2.2	2.6	4		
6	245 2nd Aud.		2.4	228	2.45	205	38		2.2	2.6	4		
7	2B0 Rect.		4.3		4.1				3.2				
8													
9													
10													

LINE VOLTAGE 106 SET ON 1 VOLTS TAP. VOLUME CONTROL POSITION Full on

SUGGESTIONS OR CHANGES MADE Set O.K.

BY _____

THREE YEARS OF THE FEDERAL RADIO COMMISSION



Admiral
W. H. G.
Bullard



O. H.
Caldwell



Col. J. F.
Dillon



Harry A.
Bellows



Judge
Eugene O.
Sykes

By L. G. CALDWELL
Formerly, General Counsel, Federal Radio Commission

The third anniversary of the enactment of the Radio Act of 1927 fell on February 23, 1930. With the enactment of that law radio regulation, which for fifteen years had been entrusted to the Department of Commerce under the Radio Act of 1912, was given over to a commission of five members for a temporary period of one year from the date of the first meeting of the commission. Certain important responsibilities, however, such as the examination and licensing of operators, inspection and investigation services, the filing of applications, the assignment of call letters, and the like, were left in the Department of Commerce. The law provided that at the end of the first year the Department of Commerce should again become the licensing authority, subject to revision of its decisions by the Commission in controversial matters which were appealed or referred to the Commission. Further provision was made for appeals from decisions denying applications for construction permit, license, renewal of license, or modification of license, to the Court of Appeals of the District of Columbia.

Commission Becomes Permanent

The Commission held its first meeting on March 15, 1927. If there had been no amendment to the law, it would have become an appellate tribunal on March 16, 1928. By virtue of three successive amendments to the law, however, the Commission has been continued as the licensing authority and, as matters now stand, it seems virtually certain to continue indefinitely as such (subject to being replaced by a Commission on Communications if Congress should act favorably on the bill now pending before it for that purpose.)

The very recent third anniversary of the formation of the Commission offers an appropriate occasion for a brief discussion of the advantages and shortcomings of the commission form of regulation of radio as they appear from the experiences of the past three years.

It would be unfair to enter upon such a discussion without reference to facts and circumstances which are not necessary incidents of commission regulation but which nevertheless have played an important rôle in shaping conditions as we find them in radio to-day. Judgment cannot be rendered on the commission form of regulation abstractly; account must be taken of the peculiar nature of the subject matter to be regulated, of the character, ability, and experience of the men to whom the regulation is confided, and of the problems and difficulties which have been imposed from without. The limited scope of this article will not permit more than passing mention of such considerations which are, however, generally known to the industry.

Ten Men in Three Years

Ten men have filled the five positions on the Commission in three years, and only one of the original appointees still holds office. Because of delays of the Senate in confirming appointments, there have been

considerable periods in which the Commission has had three members and even less. The terms of office, which under the original law were to have been on a six-year basis, have twice been cut down to one year, and at the end of each year the commissioners have been subjected to grueling inquiries as to their conduct and their views by Congressional committees. During the first year the Commission had no appropriation at all and during the last few months its appropriation has been grossly inadequate. Two men have filled the office of secretary. In the last eighteen months three men have filled the office of general counsel, and two (both borrowed from other governmental departments), the office of chief engineer.

The subject matter of radio regulation is difficult enough, merely from the point of view of its complicated engineering and economical aspects taken together with the rapid advances in the art. These have had their counterpart in legal problems which are unique in the history of jurisprudence, for the solution of which analogies fail and precedents are dangerous.

Other Problems

In addition, however, to the difficulties which are unavoidably inherent in the subject matter, the Commission at the outset found an intolerable situation of congestion in the broadcast band which has been its most perplexing problem and which was not of its making. Its solution of the problem has been hampered by the unscientific Davis Amendment and by a host of engineering and economic heresies which have found formidable advocates in Congress, among the public, and, sad to relate, even in the radio industry itself. Witness the hue and outcry against cleared channels, the complaint against the so-called duplication of chain programs, the condemnation of "high power," the advocacy of "synchronization," and the like. To the foregoing must be added the problems created by a complicated patent situation, the alleged existence of a "radio trust" and the anti-monopoly provisions of the statute, the inadequacy of existing international agreements, the political pressure constantly exercised (usually by Senators and Congressmen) in all manner of cases, the flood of mail and protests from the public (usually uninformed) and many others.

If the Commission has failed to accomplish all that was expected of it, the blame cannot be laid entirely upon its shoulders or upon the commission form of regulation generally; Congress, the public, and the industry must share the responsibility. Whether, under the circumstances, a single executive officer would have done better is impossible to say; much would have depended, of course, upon the character, experience, and ability of such an officer, just as much has at all times depended upon the character, experience, and ability of members of the Commission. While there has been a difference of opinion as

The Former Counsel of the Commission Discusses the Advantages and Shortcomings of Our Present Form of Radio Regulation as They Appear From Experiences of the Past Three Years.

to virtually every appointment made to the Commission, it must be conceded that the average quality of the appointments has been very high, in fact surprisingly so in view of the unattractive prospects and the uncertainty of tenure which go with such an appointment.

Defects in Administration

The foregoing should not be taken as indicating the writer's belief that defects have not developed in the form of regulation provided by the Radio Act of 1927. Serious defects *have* developed, both in the provisions of the law itself and in the administration of that law. Except as to a very few controversial matters, however, (such as the zone system, the Davis Amendment and the anti-monopoly and anti-merger provisions of the statute), there is remarkably little difference of opinion as to what the defects are or as to the manner in which they should be corrected. The industry generally can be of service in informing itself of the nature of the necessary changes and in supporting the recommendations so far as it finds itself in agreement with them. Already bills are in course of preparation which follow a large proportion of the recommendations of informed persons on noncontroversial matters.

With respect to the fundamental question of the form of regulation, it must be remembered that the issue is not one purely between a single executive officer on the one hand and a commission on the other. If the Radio Act of 1927 had been allowed to take its course, there would still have been a commission to which virtually every controverted matter would have been referred or appealed almost automatically; Section 5 of the Act gave the Commission plenary power (subject to review by the Court of Appeals) to reverse or revise "any decision, determination, or regulation of the Secretary of Commerce." In the years immediately preceding the enactment of the Radio Act of 1927 there was no bill pending which contemplated lodging regulation solely in the Secretary of Commerce; the most that was urged in this direction was what would have been the situation to-day if the original powers of the Commission had not been extended from time to time by Congress.

Needed Amendments

Space will not permit discussion of necessary amendments to the Radio Act which do not have some relation to the nature of the licensing authority. No discussion will be entered into, therefore, of the Davis Amendment, the inadequate procedural provisions with respect to hearings before the Commission and appeals, the undue rigidity imposed by the cumbersome provisions as to construction permits, licenses, and renewals of license, the unnecessarily drastic restrictions on the issuance of licenses to corporations with alien stockholders, officers, or directors, the anti-monopoly and anti-merger

provisions, and the penal provisions. Leaving these aside, let us inquire into what defects have developed that have more or less direct bearing on the nature of the licensing authority.

In the first place, the present form of regulation has proved defective in not giving the Commission any latitude in delegating purely administrative matters to a subordinate officer. As matters now stand, the Commission must go through the form of making a finding and a formal entry in its minutes before any license, renewal of license, or modification of license can be issued. This is a tremendous and unnecessary burden with respect to such matters as amateur, ship, and airplane licenses and, in the great majority of cases, with respect to renewals of license of any character. A single executive officer can unquestionably perform such duties more efficiently than a commission. If the law were amended so as to permit the Commission to delegate such purely administrative and routine matters to a subordinate (e. g., its secretary or a "Director of Radio"), the Commission to reserve to itself a decision on any controverted matter, the situation would not be very different from that originally provided by the Radio Act of 1927 and the law could be made to work even more efficiently than under the ambiguous and almost unintelligible provisions of Section 5 of that Act.

Lack of Stability

A second defect has been the lack of stability in the Commission manifested in an inconsistency of decisions, in its tardiness in arriving at definite policies in accordance with engineering principles in the broadcast band, and in the amount of political pressure which is constantly exercised upon it. It is significant that after nearly three years of existence, it has not yet adopted any rules and regulations other than a rather heterogeneous lot of "General Orders"; that it has established no standards on such comparatively elementary matters as the proper geographical separation between broadcasting stations of a given power on regional and local channels, or as between stations given daylight assignments on any channels (including cleared channels); that it still refrains from adopting and announcing definite policies with respect to the desirability of cleared channels and the use of high power; that it called an engineering conference for January 17, 1930, to obtain the views of engineers on such questions as synchronization and antenna construction; that it has not yet come to any conclusion as to whether the alleged unnecessary "duplication" of chain programs really exists; that, with the exception of the unsuccessful venture made in the summer of 1928 to eliminate stations, it has done virtually nothing to decrease what every one concedes to be an excessive number of stations and, on the contrary, has made the situation worse by allowing many stations of the regional

Harold A. La Fount

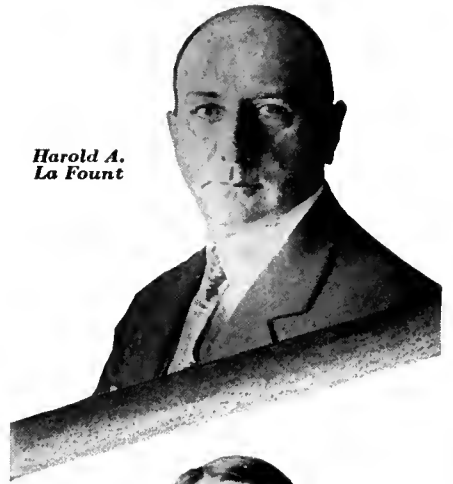

Judge Ira E. Robinson

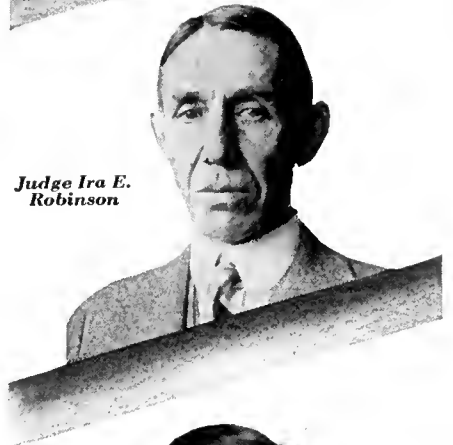

Sam Pickard



William D. L. Starbuck



Maj. Gen. C. Mck. Saltzman



class to increase in power. On the other hand, it did, by its General Order 40 and its allocation of November 11, 1928, introduce a substantial measure of improvement in the broadcast band. Whether a single executive officer would have done any better in the face of similar difficulties is at best doubtful. It is obvious that it is precisely in those matters in which Congress and its individual members have been most vocal that the Commission has



Thad H. Brown, general counsel of the Federal Radio Commission.

fallen somewhat short of following the mandates of radio physics.

The Good Points

By way of contrast the Commission has accomplished a creditable, efficient, and reasonably speedy performance of its duties in various fields of radio communication other than broadcasting. The inherent difficulties of these fields, particularly in the high frequencies, have certainly been no less than in the broadcast band but, with minor exceptions, pressure from Congress and its individual members has been absent. Opinions may differ as to the correctness of certain of the Commission's decisions on particular applications but there is virtually no criticism of the soundness of the engineering structure and standards which it has set up or as to the allocation of frequencies as between the various services. When it is considered that virtually every available frequency between 1500 kc. and 23,000 kc. has been assigned, that the applications for these frequencies were many times greater than the available facilities, and that many complicated and lengthy hearings have been held, it must be conceded that the job has been well done. For this, of course, no small share of the credit must go to the engineering advice which the Commission had from experts loaned to it by the United States Navy. In general, the Commission has followed the recommendations of engineers in all fields other than broadcasting, and has not had to contend with advice from Congress as to what is or is not sound engineering.

International Agreements

The Commission has also played its part well in maintaining the interests of the United States in international conferences. The United States delegation to the first

meeting of the International Technical Consulting Committee at The Hague in the fall of 1929 was ably headed by a member of the Commission and the results of the meeting were a matter for congratulation to the delegation. There was some complaint that the agreement entered into with Canada on March 1, 1929, covering the high frequencies from 1500 to 6000 kc., was unduly generous to Canada but one of the strongest proponents of this point of view was one of the two members of the Commission who formed part of the delegation which negotiated the agreement. There has been no criticism of the engineering aspects of the agreement.

The defects in the law and in the Commission's administration of the law which have contributed most signally to the lack of stability seem now in a fair way to being remedied. It is true that the terms of the present members of the Commission expired on February 23, 1930, and that each of the appointments to be made by President Hoover (whether of the present incumbents or of new members) will probably be subjected to close scrutiny in the Senate, with the possibility of either delay or refusal of confirmation. On the other hand, the amendment enacted by Congress in December, 1929, which extended the present powers of the Commission indefinitely "until otherwise provided by law," for the first time gives a measure of assurance of a substantial term of office, a stability of organization, and a continuity of policy. Unlike the two previous amendments, the most recent one does not shorten the terms of office to one year, and the new appointments may henceforth be made on a six-year basis. Engineers and lawyers may be employed without fear that at the end of a year their positions will cease to exist by reason of a reversion of radio regulation to the Department of Commerce.

In March, 1929, generous provision was made for employment of competent attorneys to handle the Commission's legal



Louis G. Caldwell, the author of this article and formerly general counsel of the Federal Radio Commission. Mr. Caldwell is also Chairman of the Committee on Communications (formerly the Committee on Radio Law) of the American Bar Association and Chairman of the Executive Council of the American Section of the International Committee on Wireless Telegraphy.

problems; by the recent amendment similar provision was made for engineers. It is unlikely that there will be further difficulties on the score of appropriation. It is to be hoped, therefore, that within a few months we shall have a Commission which is freed from many of the handicaps of the past three years and in a position to act with full judicial independence on controverted issues, aided by the advice of competent lawyers and engineers employed



Carl H. Butman, secretary of the Federal Radio Commission.

on a permanent rather than a temporary basis. In the meantime, the Commission is gradually freeing itself from such undesirable practices as the zone system of administration (under which system each member of the Commission gave little or no attention to matters concerning zones other than the one from which he was appointed).

The industry can contribute a great deal to the achievement of a stable, efficient licensing authority. Its various branches (and particularly broadcasting stations) can and should refrain from bringing any pressure, political or otherwise, upon the Commission, particularly where universally recognized engineering principles are at stake. They can and should refrain from misrepresenting scientific facts and principles either to Congress or to courts. The strongest support should be given the Engineering Division of the Commission in its endeavor to bring about the observance of engineering principles; the same degree of support should be given to the Legal Division in its endeavor to prevent the injustice which inevitably results from failure to observe the fundamental requirements of due process of law (which require notice and a fair hearing to all interested parties in every matter where interests other than those of the applicant are concerned).

Conclusions

There is ground for optimism, for, if the defects pointed out are remedied and if the industry coöperates as it should, the commission form of regulation will be successful. It must, however, have a fair trial. Those who, while placing every obstacle in the way of its success, point to the results of their conduct as evidence that it cannot succeed, are not serving the best interests of either the radio industry or the public.

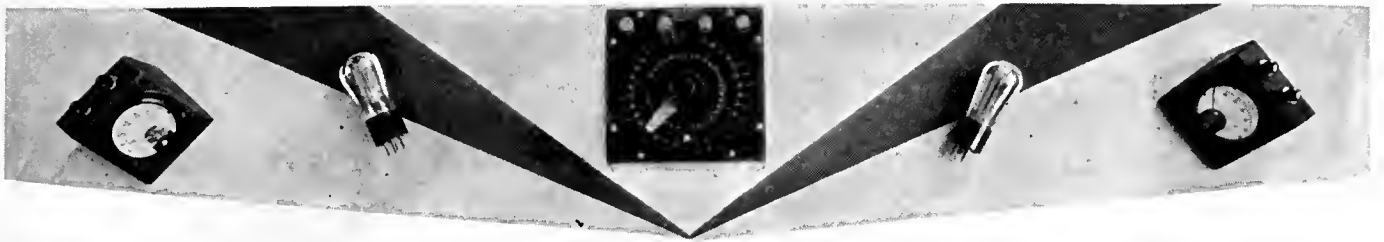

STRAYS FROM THE LABORATORY

Square-Law Detectors

ONE OF THE disadvantages of detectors which operate according to a square law, that is, where the a.f. output is proportional to the r.f. input squared, is that the stronger the a.f. input to the broadcasting station microphone, the greater is the distortion occurring in the detector. Audio tones which completely modulate the transmitter (100 per cent. modulation) produce in the plate circuit of a square-law detector a second harmonic which is 25 per cent. of the fundamental. Thus, if a 1000-cycle signal of 10 volts is produced in the output of a square-law detector, there will also be a 2000-cycle voltage of 2.5 volts in this output. Such distortion is distinctly audible to the trained ear. The greater the signal (a.f.) the greater the distortion. The actual value of the second harmonic is proportional to M^2 where M is the modulation percentage.

A graphical representation of this distortion may be constructed according to Fig. 1. Let us look at this illustration in which is plotted the relation between r.f. input to such a detector and the a.f. output. Now let us assume a fully modulated input of 2 volts. This means that at some instants the r.f. voltage is 4 volts and at some other instant it is zero. The a.f. voltage output corresponding is 16 when the r.f. is equal to 4 and zero when the r.f. is equal to zero. Now looking at the *Cunningham Tube Book*, page 19, we find a method of calculating the second harmonic distortion in such circumstances. It is equal to—

$$\frac{\frac{1}{2} (I_{\max} + I_{\min}) - I_0}{(I_{\max} - I_{\min})}$$

and substituting the above figures in this equation we get—

$$\frac{\frac{1}{2} (16 + 0) - 4}{16 - 0} = \frac{4}{16} = \frac{1}{4} = 25 \text{ per cent.}$$

The output a.c. voltage would look like that in Fig. 2 if a fully modulated wave

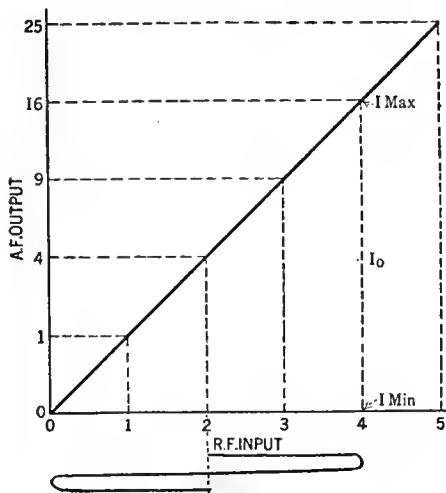

Fig. 1

of 2 volts (r.f.) were placed on a square-law detector.

Capacities of Coils

Various attempts have been made to calculate the distributed capacities of radio-frequency coils. Out of such calculations and experiments have come several interesting facts.

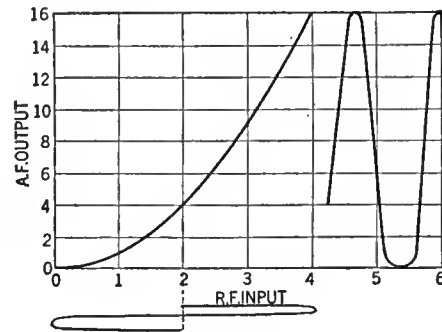

Fig. 2

In the *Journal of the Institute of Electrical Engineers*, (England) vol. IX, p. 63, Howe shows that the capacity in mmfd. of coils with a length of winding equal to half the diameter is equal to $0.6 R$ where R is the radius of the coil in centimeters. If the diameter is half the length of winding, the distributed capacity in mmfd. is equal to $0.64 R$ where again R is the radius of the coil in centimeters. In other words, the ratio of length to diameter does not change appreciably this empirical relation between radius of coil and distributed capacity.

Another interesting relation is that of Drude which states that the natural wavelength of the coil in meters is equal to 2.54 times the length of wire on the coil in meters.

Changes in Stations

The following data are taken from *The Voice of Columbia*, a publication of the Columbia Broadcasting System, Inc. They give changes in station power, etc., among members of this important broadcasting chain. The changes are prefaced with the statement that installation of crystal control and 100 per cent. modulation increases a station's signal strength by three or four times.

In Philadelphia, WCAU has increased its power from 1000 to 10,000 watts, and KMOX in St. Louis has received a permit to set up a 50,000-watt transmitter. In Detroit, WGHP is preparing to have new 1000-watt, 100 per cent. modulation equipment in operation at an improved location within the next two months.

With the installation of new equipment, WMAK in Buffalo becomes a 1000-watt station with 100 per cent. modulation, as does WSPD in Toledo with its power increased from 500 to 1000. In Boston, WNAC has installed a new 1,000-watt, 100 per cent. modulation transmitter at a loca-

tion which gives good New England coverage. Within the next few weeks, when its new equipment is installed, WKNC in Cincinnati plans to increase to full time and operate at maximum efficiency. Installation of 1000-watt, 100 per cent. modulation equipment is completed for KOIL in Council Bluffs. At Fort Wayne, WWOV has a 50,000-watt transmitter which is all set to go when the word is given. KMBC in Kansas City and WLBI in Oil City have installed 100 per cent. modulation facilities and an order for similar equipment has been placed by WJAS of Pittsburgh.

About a month or so from now, WHK of Cleveland should have its new 5000-watt, 100 per cent. modulation transmitter replacing its present 1000-watt equipment, and in a more advantageous location.

Quartz Crystals

Quartz crystals may be obtained from the Crystal Grinding Laboratories, 215 West Cook St., Santa Maria, California, at the following rates: 3500-3650-kc. band, \$7.50; 1750-1825-kc. band, \$5.00; Oscillating blanks, \$3.50. The Laboratories offer immediate service; frequency to within 0.1 per cent.

A Correction

An unfortunate error occurred in the article in January, 1929, RADIO BROADCAST, entitled "A Radio Dealer's Tube Tester." Fig. 2, a circuit diagram, was incorrect. The correct diagram is given in Fig. 3 on this page. The lamp, B, should be connected to the grid terminals of the tube sockets and not to the plate terminals as indicated in the January issue.

Recent Articles of Interest

An analysis of the design and applications of beat-frequency oscillators is contained in the *General Electric Review*, October, 1929. The article, by M. S. Mead, Jr., describes not only the construction of an instrument built by the General

(Continued on page 302)

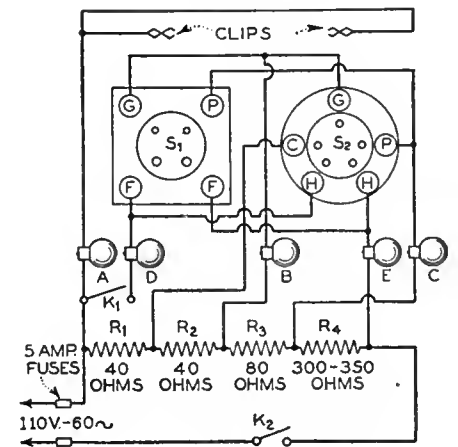

Fig. 3



PRODUCTION TESTING EQUIPMENT

This device for measuring the resistance of wire-wound resistors within 1 per cent. is attached to each winding machine.

By J. A. CALLANAN
Stewart Warner Corporation

In this, the third of a series of articles dealing with production testing of radio appurtenances, the discussion centers around the testing of a miscellany, which, while just as important as either capacitances or iron-cored items, does not come under either group. For example, the testing of r.f. coils is, in the writer's opinion, secondary in interest only to the testing of gang condensers. The acceptance limits must, of course, be held just as closely as those of gang condensers as they are used in conjunction with one another.

Testing R. F. Coils

In testing r.f. coils we have tried a number of systems, including matching sets of coils, adjusting turns, etc., but have found that all of these resulted in manufacturing difficulties which made them impractical. Several years ago we tried the matched-set system in which every coil is graded according to the position of a condenser dial at which the tuned circuit resonates. The coil is then marked high, medium, or low and is used with a condenser conversely marked. Our manufacturing, repair, and service stations branches soon protested, and, while we operated with this method

that year, the system was more costly than either the turn-adjusting system or our present one. The turn-adjusting method was very good, but it was not very fast and therefore required more labor. From these experiences our present system was evolved; it is neither costly nor slow and has been entirely satisfactory to all concerned. For those who may be interested in a similar procedure a detailed description of our coil-winding and inspection system is given below.

Upon receipt from the factory the coil forms are first dried to prevent a possible variation in size due to the absorption of moisture in shipping. They are next placed in a double split ring gauge which measures the circumference at either end of the coil form. A dial indicates the average circumference to the thousandth part of an inch. The gauge is necessarily constructed so that even if the shape of the coil form is distorted a true circumference reading is obtained. In our particular case we find that a difference in size of 0.003 inch makes a $\frac{1}{2}$ -turn difference in winding so we have made our factory acceptance limits plus and minus 0.003". This makes a difference of one full turn in apparent inductance, or,

in other words, gives us three possible groups of coils, viz. minus $\frac{1}{2}$ turn of 150 turns (our standard), 150 turns, or $150 + \frac{1}{2}$ turns, and each is interchangeable in the completed receiver.

The tested coil forms are first punched and wound with the required number of turns as shown by the inspection ticket, the coils being space wound to prevent error due to varying wire diameter. The coils are then doped and soldered after which endless belts or conveyors carry them along until they are placed in the receiver.

Our coil test equipment consists of two types of machines, one for the "A" coils with relatively few primary turns and the other for "B," "C," and "D" coils which have sufficient primary turns to resonate below the broadcast band when connected in parallel with the tube capacity. The schematic diagram of the "A" coil machine is given in Fig. 1, while the machine for testing B, C, and D coil is shown in Fig. 2 and the accompanying picture. These test fixtures consist of a crystal oscillator to which is coupled the coil under test, resonance being indicated by a V.T. voltmeter connected across the coil.

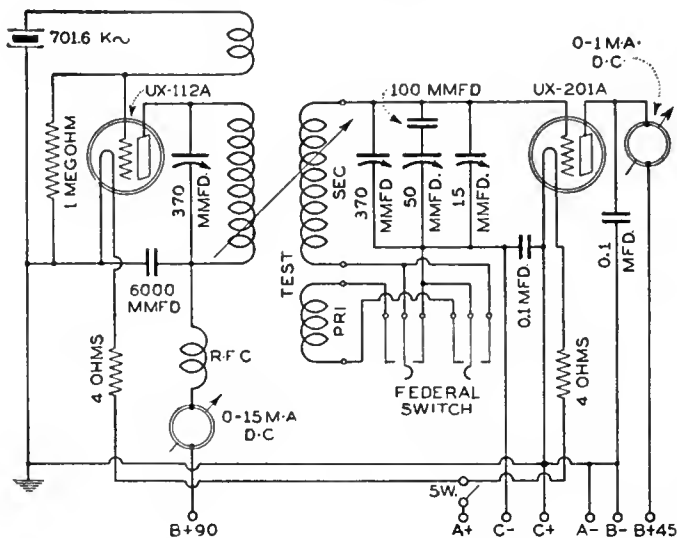

Fig. 1—Circuit for checking low-inductance r.f. transformers. A crystal oscillator supplies the power and the coil under test is connected in the grid circuit of the V.T. voltmeter tube. The secondary is first checked alone and then primary and secondary are connected, series aiding, to test both windings and the mutual inductance between them.

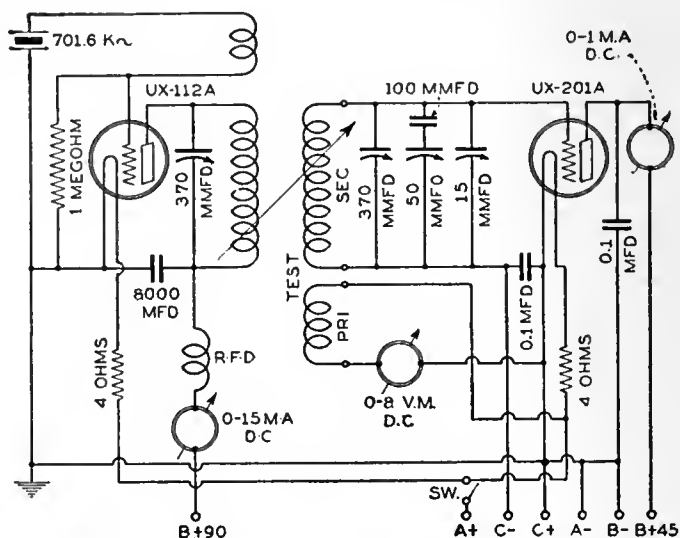

Fig. 2—This circuit for checking high-inductance r.f. transformers operates in a similar fashion to Fig. 1 except that only the secondaries are tested, the limits being plus or minus one half turn. All primary coils are tested for resistance and only a small percentage of the production receives an inductance test. The rejects run about 1 per cent.

PART III—

Apparatus Designed and Used by the Stewart-Warner Corporation for Testing Radio-Frequency Coils and Chokes, Loud Speakers, and Wire-Wound and Fixed Resistors.

The calibrated condenser is of the transmitter type and is equipped with special bearings to resist wear. The "A" coil machine (Fig. 1) is made so that the secondary is first tested alone and then by a throw-over switch the primary and secondary are connected in a series-aiding circuit. In our particular case where a variable antenna compensating condenser is connected across the "A" coil secondary, the inductance limits are rather broad, plus and minus one turn for the secondary winding and two turns for the primary and secondary in a series-aiding circuit.

The "B", "C", and "D" coil machine differs only in that the secondaries alone are tested for inductance with limits of plus and minus $\frac{1}{2}$ turn, the primaries being tested for d.c. resistance with a simple ohmmeter. We have found this d.c. reading to be just as satisfactory an indicator of the primary as an inductance test, though, as in other branches, an inductance test is run on a percentage of the primary windings. Our production department reports that rejections run approximately 1 per cent. with this system. The 0-15-m.A. meter indicates the condition of the crystal oscillator while the 370-mmfd. variable condenser in the tank circuit controls the power output. The condensers in the V.T. voltmeter are to adjust the circuit to

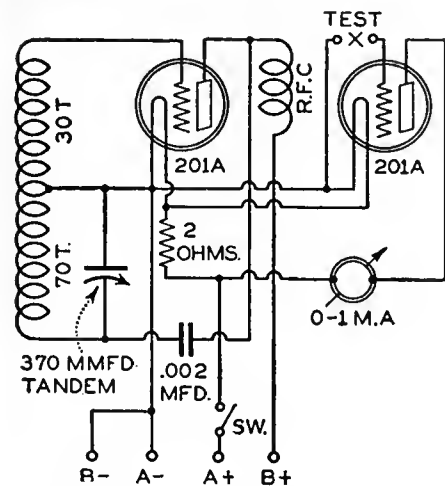
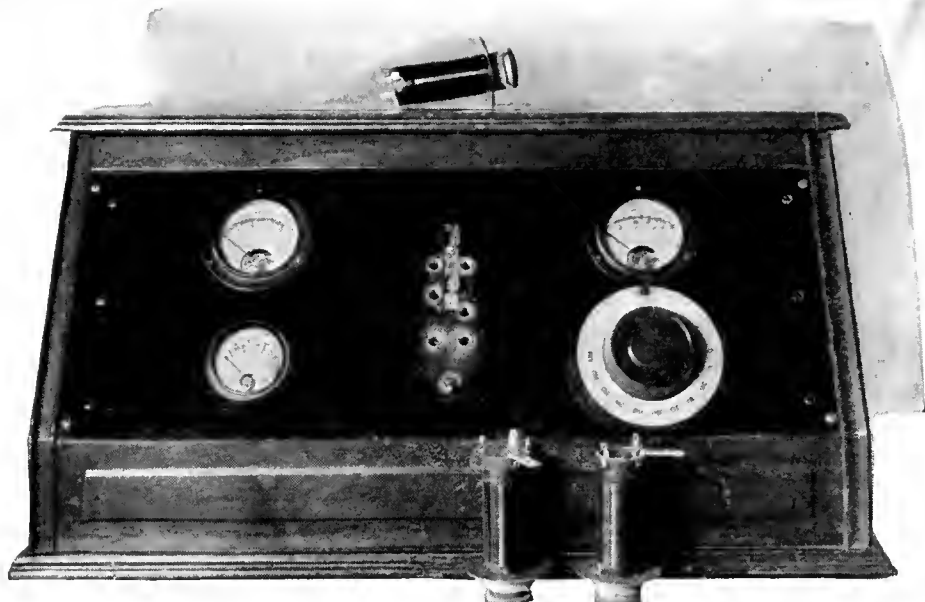

Fig. 3—In testing r.f. chokes with this apparatus the resonant frequency is checked by adjusting a 750-mfd. condenser. All chokes resonating in or near the broadcast band are rejected.



High-Inductance r.f. transformers are tested with this device. It contains a crystal oscillator coupled to the coil under test and a V.T. voltmeter to indicate resonance. The circuit is given in Fig. 2.

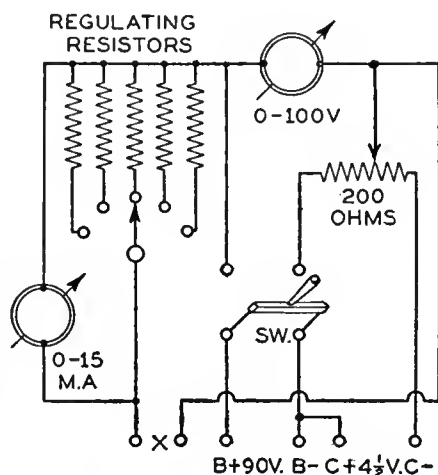

Fig. 5—Carbon resistors are tested by passing through them a current approximating normal and measuring this current with a milliammeter and the voltage across the resistor with a voltmeter.

resonance when a standard coil is connected, while the arrangement for connecting the coils in the circuit is shown in the picture. These test sets use one 6-volt A battery and two 45-volt B batteries.

Testing R.F. Chokes

The testing of r.f. chokes is very similar to the testing of r.f. coils except that, as the limits are broader, we do not find it necessary to use a crystal oscillator. As shown in Fig. 3 the coil under test is coupled to an oscillator whose frequency is made variable by means of a 750-mmfd. tandem variable condenser. Resonance is indicated by a simple V.T. voltmeter and limits are painted on the dial. The operator rejects chokes which resonate near or in the broadcast band while those resonating between 300 and 500 kc. are accepted. This test set uses one A battery and one 45-volt B battery.

Loud speaker coil testing is accomplished by first testing for shorted turns with the test fixture described in last month's article and then measuring the resistance with an ohmmeter. Very little trouble is experienced here because automatic counters are used in winding.

The testing of wire-wound resistors on a production basis is not difficult as far as

testing is concerned but is often an expensive item because of the quantity used in the average receiver. A good bridge or ohmmeter costs from \$50.00 to \$100.00 and can only be used by one operator, so where there are 25 to 50 girls winding resistors, if each were to have a tester this would become quite an item. We have designed a simple bridge circuit costing about \$10, one of which is attached to each winding machine. As this enables the operator to wind exactly the right amount of resistance wire our resistor rejections are less than one per cent. and this is due to breakage and not to incorrect resistance.

As may be seen by referring to Fig. 4 and the picture, the test fixture consists of a bridge with two standard legs and a high- and low-limit arm, either of which may be inserted by a throw-over switch. This switch also serves to break the battery circuit. The binding posts in the front of the fixture are so that it may be connected to the winding machine while the contact points are used in testing completed resistors directly. The arrangement is sensitive to differences in resistance of 1 per cent. and is not affected by battery poten-

(Continued on page 301)

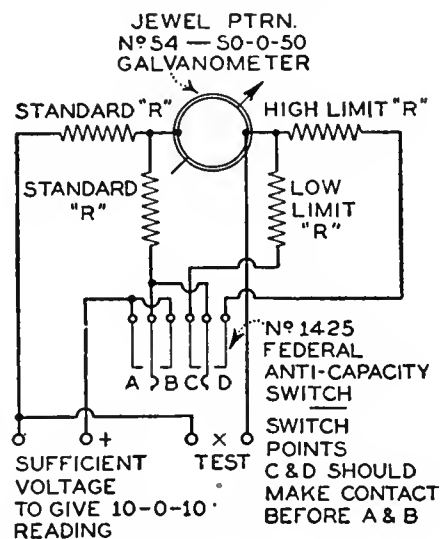

Fig. 4—Wire-wound resistors are checked within 1 per cent. by means of this bridge system which is attached to the winding machine. Changes in battery potential do not affect its accuracy.

RATING RADIO RECEIVERS

By **ALFRED H. GREBE**
President, *A. H. Grebe & Company, Inc.*



The author in the laboratory checking the work of Grebe engineers.

A Method Offered by A. H. Grebe & Company, Inc., as a Solution to the Problem of Describing to the Non-Technical Public the Merits of a Particular Broadcast Receiver.

Newspaper and magazine advertising of radio receivers consists mostly of high-sounding adjectives. It was our feeling that performance claims backed by definite quantitative measurements would form a better basis of advertising than vague claims of superiority. This desire to find a reasonable basis upon which to write

Grebe copy has been responsible for the use of a new type of advertisement by our company.

Our present series of advertisements have been based on a series of measurements on a number of standard makes of radio receivers. The technical data which forms the background of these tests are described in the following paragraphs.

In the rating of receivers there are three factors of major importance—sensitivity, selectivity, and fidelity. Stating these factors in engineering terms such as so many microvolts per meter, or a loss of so many μ at 5000 cycles is understandable to engineers but means little to the layman. We have, therefore, endeavored to work out formulas for these various factors which will permit their expression in percentages so that a set has a fidelity of say 50 per cent., a selectivity of a certain percentage, and so forth.

and there is a great variation between sets. We are therefore using the selectivity at 1400 kc. as a basis for comparison of sets, and are taking the width of the selectivity curve at 100 times the input at resonance. Therefore, if a set has a band width of 40 kc. it means that if our signal were 20 kc. off resonance on either side, the input to the set would have to be increased 100 times to give the same loud speaker output that we would have obtained with the set tuned to the signal. Since the sides of the selectivity curve are fairly straight, a set with a band width of 40 kc. at 100 times input would have a band width of about 20 kc. at 10 times input. This means that a station of equal strength on an adjacent channel (10 kc. off) would only produce one tenth the signal in the detector, and this is not enough to interfere with the station to which the set is tuned.

Therefore, a set with a band width of 40 kc. can be said to have "10-kc. selectivity" over the entire broadcast range. As a matter of fact, a set having 40-kc. band width will give 10-kc. channel selectivity even though the interfering signal on the adjacent channel is twice as strong as the desired signal. A set having 50- to 55-kc. band width is still capable of giving 10-kc. channel selectivity provided the interfering signal is no stronger than the desired signal.

We have given a set with a band width of 40 kc. at 1400 kc. a rating of 100 per cent. in selectivity. The curve of per cent. rating against band width has been made steeper in the neighborhood of 40 kc. because a 1 kc. improvement in band width here is more difficult to obtain, and is also worth much more than the same improvement at a band width of, for example, 100 kc.

Sensitivity

The sensitivity of a set is expressed in terms of the voltage input to antenna required to give a fixed output to the loud speaker.

The figures used are in microvolts per meter. The actual input to the antenna of the set is four times this figure, since a standard antenna is assumed, having an effective height of 4 meters.

The lower the figure for sensitivity the

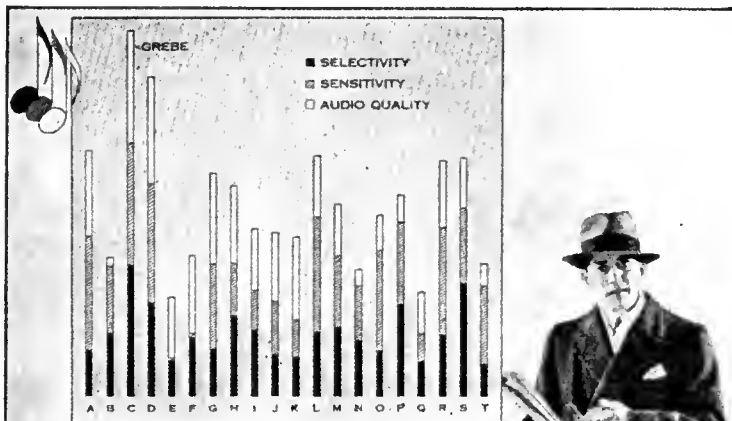

Cynic turns fan

TABLE the superlatives when he comes in; don't hear down with sales talk; this hardened cynic wants evidence. And on this chart he finds the facts that show him exactly what to expect of the Grebe—clear-cut comparisons that shatter his shell. Now let him listen to the set that is newer than screen grid and watch him turn fan.

He is critical but his demands are not unreasonable when put to the Grebe. This set satisfies them with plenty to spare for it is at least a year ahead of the field. Show him how sharply the Grebe separates one station from

another. Thrill him by reaching out for weak, distant broadcasts. Close the sale with the lifelike tone that enables him to identify every instrument, every voice.

Then, after he has signed on the dotted line, he sure you deliver on time. You know how it is with this type of buyer; once you have sold him, you cannot get the set to his home quickly enough!

There is extra profit in the Grebe franchise. In addition to

getting normal business, it sells those who would not otherwise be ready for another year.

Grebe radio

A. H. GREBE & COMPANY, Inc., Richmond Hill, New York
Western Branch, 443 So. San Pedro Street, Los Angeles, California

Alfred H. Grebe—"In the new folder being distributed to the public by our dealers we prove the uniformly high quality of this new set in every important characteristic of radio reception. We support the statement that Grebe prices will not be reduced with the pledge that Grebe quality will not be reduced. To franchise-holders this means that profits will not be reduced—that every sale will continue to yield a worthwhile return."



The advertisement above is indicative of the way in which Grebe explains the merits of its product to the non-technical public.

Selectivity

The ability of a set to receive the desired station without interference from another signal on an adjacent or nearby channel is indicated by the selectivity curves. The selectivity of all sets is roughly the same at the lower broadcast frequencies, but on higher frequencies the selectivity becomes much worse

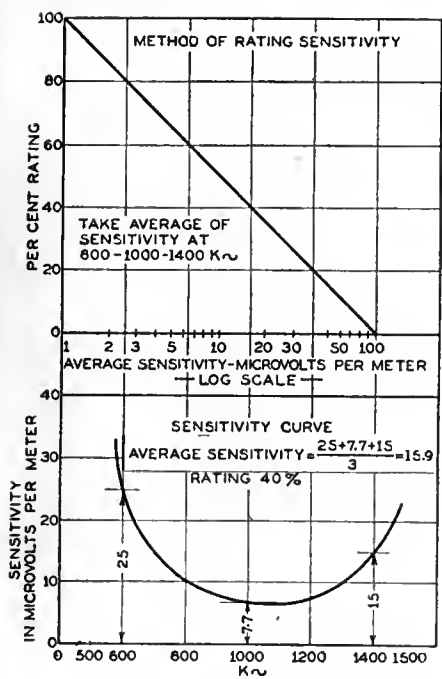

Fig. 1

more sensitive is the set. We have given a sensitivity of 1 microvolt per meter 100 per cent. credit. No set has been found that is quite this sensitive. A sensitivity of 100 microvolts per meter has been given zero credit since a set having such a sensitivity would only be able to get a few distant stations, and would be unable to get some of the weaker local ones.

In order to penalize those sets whose sensitivity varies widely over the broadcast range we take the average of the sensitivity at 600, 1000, and 1400 kc. The curve of per cent. rating against sensitivity uses a log scale since the response of the ear is logarithmic. Fig. 1 shows how average sensitivity is determined and the relation between average sensitivity and the per cent. rating.

Fidelity

The a.f. curve of the set is taken from the detector

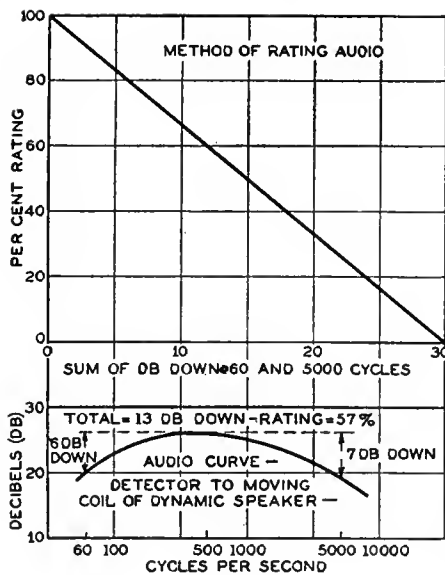

Fig. 2

to the moving coil of the speaker. The amplification is expressed in decibels, which is a logarithmic unit. The useful frequency range taken as from 60 to 5000 cycles per second, and the set is given a 100 per cent. rating if it amplifies equally all frequencies between these values. Most sets have maximum amplification at 500 cycles per second and fall off somewhat as the frequency is either increased or decreased. As an in-

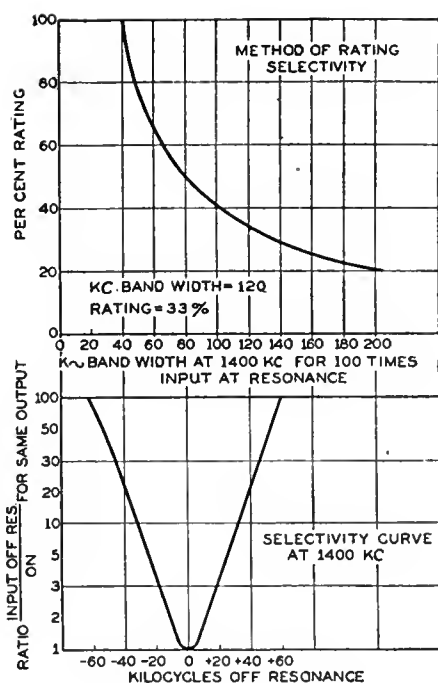

Fig. 3

dication of how much it varies we take the difference between the amplification at 60 and 600 cycles per second expressed in decibels, and add to this the difference between the amplification at 5000 and 500.

This gives the total decibel variation from uniform amplification.

A set with a total variation of 30 decibels has been given a rating of zero.

In the three charts on this page will be found examples which indicate quite clearly the method used in indexing the selectivity, sensitivity, and fidelity characteristics of radio receivers. In addition, the table on the left shows the ratings which have been assigned to twenty standard receivers and the method of converting band width, microvolts per meter, and total decibels loss into corresponding percentage ratings. The overall rating is the average of these three ratings.

SET	SELECTIVITY		SENSITIVITY		FIDELITY		TOTAL % Selectivity, Sensitivity, and Fidelity	OVERALL % Total % 3
	Band Width at 1400 kc.	$\frac{60}{\text{Band Width}} \times 100$ (% Selectivity)	Average $\mu\text{V/m}$ 600, 1000, and 1400 kc.	$(1 \frac{1}{2} \text{ Log Saver})$ $\times \frac{100}{\text{Sensitivity}}$ (% Sensitivity)	Sum of DB loss at 60 and 500 cycles	$\frac{30 - \text{Sum}}{30} \times 100$ (% Fidelity)		
1	43	93	1.75	88	5.5	82	263	87.6
2	61	66	2.	85	7.	77	228	74.0
3	120	33	2.3	82	11.7	61	176	58.7
4	88	45	2.2	83	16.4	45	173	57.7
5	50	80	7.9	55	18.8	37	172	57.3
6	90	44	2.6	78	15.6	48	170	56.7
7	122	33	5.7	62	10.1	66	161	53.7
8	70	57	29.1	38	12.9	57	152	50.7
9	61	66	6.66	59	23.9	20	145	48.3
10	81	49	9.	52	18.8	37	138	46.0
11	124	32	3.5	73	22.6	25	130	43.3
12	83.6	48	26.2	29	16.7	44	121	40.3
13	136	29	16.2	39	14.9	50	118	39.4
14	154	26	29.4	27	11.7	61	114	38.0
15	95	42	89.	03	13.3	56	101	33.6
16	90	44	10.3	49	28.	07	100	33.3
17	185	22	7.4	57	25.1	16	95	31.6
18	102	39	15.9	40	26.4	12	91	30.3
19	156	25	41.3	19	20.6	31	75	25.0
20	176	23	110.	2	16.1	46	71	23.6



Two Grebe engineers at work in the laboratory measuring the characteristics of a broadcast receiver.

TRICKS WITH SET TESTERS

By HERBERT M. ISAACSON
Engineering Dept., Colonial Radio Corp.

Using a Trouble Diagnoser to Measure Inductance, Capacity, and Resistance.

In the November, 1929, issue of RADIO BROADCAST the writer described a radio set diagnoser of his design. As explained in the first article this instrument is capable of performing all the tests which may be made with a standard set tester and in addition it may also be used for measuring resistance, capacity, and inductance. As interest in the diagnoser has been so great it has been decided to give data on making the latter measurements. Also, certain omissions occurred in the wiring diagram which accompanied the original article and therefore a revised circuit will be found on this page.

Resistance Measurements

The usual method of measuring resistors is to read the current with a known voltage impressed across the resistor. This method does not lend itself readily to the measurement of resistors of large value, since an unreasonably high voltage would have to be used to secure a readable deflection on the 10-milliamper meter scale. However, for measuring resistors which have a value comparable to that of the voltmeter multiplier resistors there is a very simple method which may be used. Using a voltage that gives a large-scale deflection on the voltmeter range selected, take a reading with the resistor under test in series with the voltmeter and a reading without the resistor. If V is the voltage reading without the resistor, v the reading with the resistor in series, R the resistance of the voltmeter range used, and r the unknown resistor value, then $r = \frac{(V-v)R}{v}$. For instance, if the resistance value of a grid leak were to be determined, and the voltage as indicated on the 100-volt scale without the grid leak in series was 90 volts, and with it in series was 5 volts, then $r = \frac{(90-5) \times 100,000}{5} = 1.7$ megohms.

Measuring Capacity

The capacity of a filter or by-pass condenser may be measured by either of two methods. The first makes use of the fact that the reactance of a condenser is inversely proportional to its capacity and with this method it is necessary to know the impedance of the a. c. voltmeter. Its impedance, which can be considered equal to its resistance without introducing an appreciable error, can easily be determined by either of two

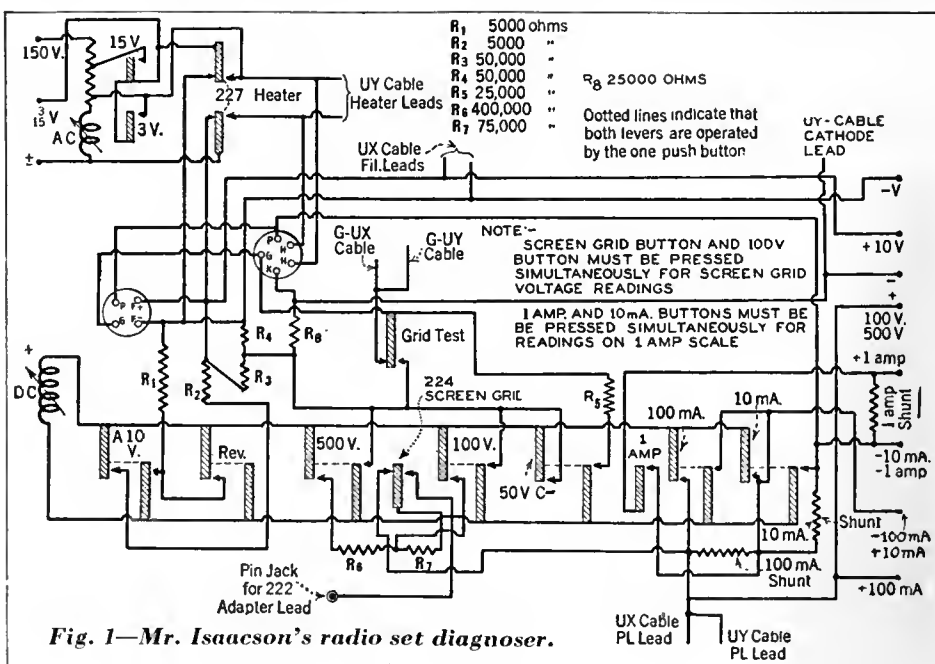

Fig. 1—Mr. Isaacson's radio set diagnoser.

means. When direct current is available a measurement of the current through the meter when a known voltage is impressed across it will give the resistance by dividing the value of voltage by the value of current. The other way is the "half-current method." It calls for inserting in series with the voltmeter a resistor of such value that the meter reading is reduced to one-half of that obtained without the resistor. Either a.c. or d.c. may be used and the resistance of the meter is considered equal to the resistance of this external resistor. To ascertain the unknown value of a capacity, take a reading of the a.c. line on the 150-volt a.c. scale and call it V . Take another reading with the condenser under test in series with the meter, and call it V_1 . Then the value of capacity in mfd. is $\frac{2652.5}{K R}$ where R is the voltmeter resistance and K is a constant, the value of which depends on the ratio $\frac{V_1}{V}$ and is given in the table.

For illustration, suppose the line voltage reading on the 150-volt scale of a 40-ohm-per-volt meter were 120 volts. With the capacity in series with the meter, the reading would fall to 84 volts. The ratio $\frac{V_1}{V}$ is $\frac{84}{120}$ or 0.7. Consulting the table we find a value of 1 for K when $\frac{V_1}{V} = 0.7$. Then $C = \frac{2652.5}{6000} = 0.44$ mfd.

The second method, the so-called ballistic-galvanometer method, is based on the fact that the charge in a condenser is directly proportional to its capacity. Charge a condenser of known capacity at a convenient voltage (90 volts is handy). Connect the 100-volt d.c. scale of the diagnoser across the condenser and note the highest reading of the pointer (with the supply voltage disconnected, of course). Now charge the condenser under test at the same voltage and observe the reading when it is discharged through the voltmeter. If C is the first capacity, c the unknown, V the first voltmeter reading, and v the reading with the unknown capacity, $c = \frac{Cv}{V}$.

The first method is by far the easier, but where a.c. is not available, it is necessary to fall back on the ballistic-galvanometer method.

Measuring Inductances

Inductances of large values such as are used for filter chokes may be measured in a manner similar to the first one described for capacity measurements. A line voltage reading, V , and a reading with the choke in series with the meter, V_1 , are taken. The inductance, in henries, is then equal to $\frac{K R}{377}$ where R is the voltmeter resistance and the value of K depends on the ratio $\frac{V_1}{V}$ as before, and is given in the table. For example, assume a line voltage reading of 115 volts, using a 6000-ohm meter. With the inductance in series, the reading falls to 51 volts. $\frac{V_1}{V} = \frac{51}{115} = 0.44$. From the table we find $K = 2$. Then $L = \frac{2 \times 6000}{377} = 31.8$ henries.

This formula is more "vigorous than rigorous," since it assumes that the reactance of a choke equals its impedance. However, for practical purposes the error introduced is negligible.

(Continued on page 282)

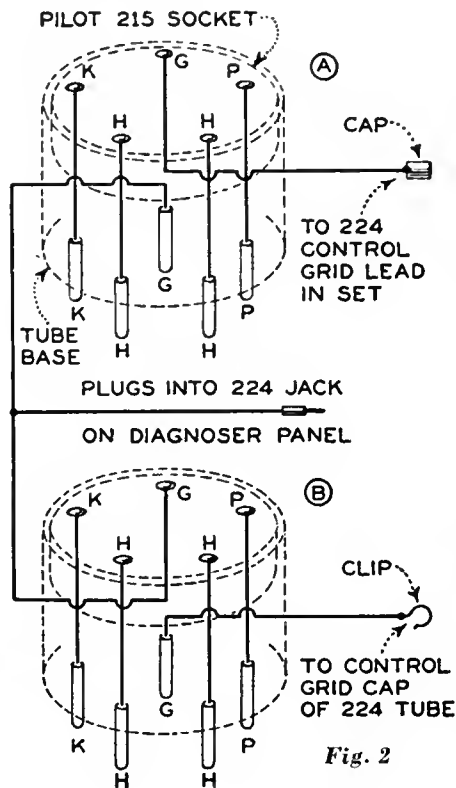

Fig. 2

PROFESSIONALLY



SPEAKING

REGARDING PENTODE ARTICLES

A number of articles have been published in RADIO BROADCAST, and also in several foreign radio periodicals, on the pentode, a new five-element tube designed for power output purposes. It is a tube which, with less grid excitation, will deliver as much power output as present-day tubes—in other words, it is more sensitive. On the other hand, there are other types of pentodes which will deliver the same power output as present tubes on a smaller consumption of plate power. The new tube is therefore more efficient.

A few set manufacturers do not like the appearance of such notes and articles on new tubes. They say the industry is already bothered with too many tubes; that new tubes come along faster than the set manufacturers can get ready for them, they appear sooner than they can engineer good sets for them, and are put on sale before the tubes themselves are fully developed. Therefore, any announcement of a new tube tends to unsettle the industry. They believe, therefore, that the thing to do is to keep quiet, brag up present-day sets, and beat the drum in the band wagon.

The Editors of RADIO BROADCAST have no desire to upset the industry, but they do not feel flattered at being part of an industry that is so unstable as to be unsettled by publication of news of a new foreign tube which may or may not have to be reckoned with in this country.

On the other hand, the Editors feel an obligation to present the most complete and authentic information on the latest technical developments to the several thousand engineers who read RADIO BROADCAST.

Many of these engineers have flattered the Editors into believing that the tube articles (the first appeared in 1925 and were widely reprinted by tube and set manufacturers) which have appeared in this magazine were timely and useful. It may be remembered that the first laboratory data on the screen-grid tube, except that published by Dr. Hull in the *Physical Review*, were published in RADIO BROADCAST. Unfortunately not many radio engineers read the *Physical Review* or the foreign technical papers, and, therefore, until the technical articles appeared in this magazine only a few radio engineers knew much about this tube which has come into such favor within the past year. Similarly the first articles on the pentode published in the United States were in the technical columns of RADIO BROADCAST.

Engineers may expect in RADIO BROADCAST as much material as it is possible to get on pentodes or on any other technical matter of interest or importance to them.

The Editors do not believe that publishing technical data about impending developments will accelerate the growth

of gray hairs in any manufacturer's head and regret that any manufacturers feel that such articles will impede the sale of present models. They do not believe that the fault is with releasing information on technical developments—progress, some call it.

You can pull down the shades in the morning if you want to sleep after sunrise—but you cannot prevent the sun from coming up.

Attention—

A promise to keep engineers informed of progress and technical developments.

Should radio salesmen be informed of what's under the lid?

Let's be thankful that we do our radio listening in America.

ARE TECHNICAL SALESMEN NEEDED?

How much technical knowledge a salesman or dealer should have seems to be a question that occasionally agitates manufacturers of radio receivers. In general the question is or has been dismissed with the thought that the public knows nothing at all about what is inside the box, and the salesman need know but little more.

We believe that this attitude is not conducive to selling the maximum possible number of radio receivers. It is true that the general public knows and cares but little about linear detectors, microvolts per meter, or milliwatts output, and that a salesman seldom finds it necessary to drag such terms into the conversation prior to closing the deal. But on the few occasions when a salesman finds a customer who wants an explanation of linear detection or screen-grid amplification, the dumb salesman cannot help being dumb and probably finds that his commonplaces about superior sensitivity or selectivity do not help him to fill the dotted line.

The dealer's salesman who is best equipped to talk about the set he is trying to install in a prospect's home, has, in our opinion, the best chance of removing that radio from his employer's storeroom. The salesman who persists in talking grid leaks and C bias to non-technical customers is not a good salesman anyhow, but the salesman who is poorly equipped to sell a technical product may find himself in the unenviable position of knowing less about his product than does his customer.

It is our opinion that the manufacturer should make every effort to interpret to his dealers what is under the lid; why it is technically better than others; what technical terms really mean to the consumer, etc.

Perhaps the greatest contribution of the screen-grid tube is greater freedom from annoying hum—yet we have not heard of a dealer who mentioned this advantage.

IMPROVEMENTS IN MONITORING

One of the outstanding achievements of the radio year 1929 was the broadcasting of the Philadelphia Symphony Orchestra under the baton of Mr. Stokowski. The Philadelphia Storage Battery Company deserves commendation for sponsoring programs of such merit, and the National Broadcasting Company's engineers who carried the symphony to the radio audience must share in the credit, too.

In these days when any aggregation of musicians that someone pays to go on the air is a symphony orchestra; when anyone who wields a baton is a maestro; in these days of severe monitoring of symphonies so that fortissimo and pianissimo sound alike in a rather deadly monotone; in such days it means something for a listener to be able to hear Mr. Stokowski's orchestra because of the excellence of this organization—and because Mr. Stokowski was his own "monitor."

The leader of this famous orchestra had apparently listened to the broadcasting of full symphonies in which the peaks and hollows of volume were electrically leveled off for radio; he had heard the audible manipulation of the gain control; and, like many careful listeners, had been disgusted. Hence he had the volume level indicator mounted where he could see it, and conducted his orchestra so that the volume was kept between the desired limits.

Normally as soon as the orchestra goes up in volume, the monitor operator cranks the volume down so that the differences of level are ironed out. The effect of Mr. Stokowski's monitoring was one of listening to an orchestra which turned out much greater volume differences of level.

Conditions in this country are not as bad as they seem to be in England where one listener complains that "efforts of monitors to vary the volume inversely to the conductor of the orchestra have reached such a pass that they have almost attained the engineer's dream of transmitting a pure sine wave of unvarying frequency and amplitude as a means of musical entertainment."

Another British listener complains that announcers come on so loud after a musical selection that they must be toned down at the receiver. Then, when the music comes back, it is so weak it cannot be heard and the listener must again adjust the volume control. He describes a piano recital in a studio beginning in such a fashion as to suggest that the pianist with his opening chords had broken 80 per cent. of the strings of the piano. Then a monitor reduced the volume about 300 per cent. and only about 10 per cent. of the strings seemed to have been damaged.

Let us be thankful we listen in America and that occasionally someone like Philco broadcasts something like the Philadelphia Symphony Orchestra. Let us be thankful for Mr. Stokowski's monitoring and for the excellence of transmission made possible by the NBC engineers.

MAGNETIC CIRCUIT DESIGN

(Continued from page 266)

given condition. Several of these curves are shown in Fig. 2. Determining $\tan \theta$ from a knowledge of the air-gap and magnet dimensions will in general determine the material of which the magnet is to be made. If all considerations except that of maximum flux density are neglected, the choice of the magnet material will rest on that which gives the highest intersection on the B-H curve with the line drawn from the origin making an angle θ with the vertical through the origin. Two cases are shown in Fig. 2. In the first case the air-gap dimensions and the arbitrary values for the magnet dimensions determine the angle θ . In this case quite clearly tungsten or chrome steel gives a higher flux density in the air-gap than 15 per cent. cobalt steel. In the second case the reluctance of the air-gap is considerably higher than before and a larger angle θ is determined. If the maximum flux density in the air-gap is again the primary consideration, it is obvious that cobalt steel is a more desirable choice than tungsten or chrome steel.

Other Considerations

Unfortunately there are also other considerations. If the magnet is necessarily very short because of limited space or limitations of weight, as in a telephone receiver or phonograph reproducer, tungsten steel may not be capable of withstanding the ageing and demagnetizing effect of the free poles of the magnet, and cobalt steel would have to be used regardless of the results determined as shown above. Another consideration that may vitiate these results is that of cost. Cobalt steel is considerably more expensive than tungsten steel in forging and heat treating, in the operation of magnetizing, and particularly in first cost. Thus the engineer in designing a magnet must study these conditions, simultaneously attributing to each condition its relative importance.

The value of $\tan \theta$ in certain designs of magnetic structures may be rather large. In such cases it may be well to observe the extent of the demagnetizing effect of any alternating magneto-motive forces, if any such demagnetizing forces exist. A method of making such an observation is shown in Fig. 4. Tangent θ is determined in the usual way, and drawn on the B-H curve determining the operating point A. The alternating magneto-motive force about the point A is then determined as follows: Determine the maximum amplitude of the counter magneto-motive force due to the signal current in any coils directly connected with the permanent magnet system, and due to any changes occurring in the length of the air-gap. Divide the maximum amplitude of the counter magneto-motive force by the length of the magnet. This quantity should have a lower order of magnitude than the coercivity value MN of Fig. 4 determined by the value of $\tan \theta$. If it does not have a considerably lower value than MN, the permanent magnet may eventually be demagnetized. The flux cycle due to the alternating component of magneto-motive force is shown in Fig. 4. The initial flux density in the magnet is that of point A. If the alternating magneto-motive force has an initial positive swing the flux density of the magnet will follow the curve as shown and eventually trace the curve QR. The length of this loop should be small compared with MN.

Limitations in Practice

A permanent magnet may be used to supply the magnetic field in the air-gap

of an electrodynamic loud speaker. The earliest attempts of accomplishing this result made use of many comparatively short magnets in parallel. That the required conditions would be difficult to satisfy by this method becomes quite obvious when one considers the equation for the angle θ drawn on the B-H curve,

$$\theta = \arctan \frac{\text{air-gap length} \times \text{magnet area}}{\text{magnet length} \times \text{air-gap area}}$$

The numerator of this fraction is already very large, because the air-gap length of an electrodynamic loud speaker is comparatively large, and, therefore, the angle θ tends to be large. Using a number of magnets in parallel increases the angle θ to still larger values with the result that the flux density in the magnets has a very low value, and negligible increases in the flux density in the air-gap are obtained as the area of cross-section or the number of parallel magnets is increased.

If the magnet is designed more nearly in accord with the design equation for permanent magnets using tungsten or chromium steel as the material in the magnet, the magnet will have to be made very long. Leakage flux in a long magnet may be considerable, and it is not inconceivable that the leakage flux over the complete assembly consisting of the magnet, pole pieces, and connecting parts may actually amount to more than the total number of maxwells in the air-gap itself. Such results are not uncommon.

A shorter magnet may be used, however, if the magnet is made of steel of very high coercivity. Steels can be obtained having coercivities of the order of 250 gilberts per centimeter length. This value is, of course, a considerable improvement over that for tungsten steel which has a value of about 63 gilberts per centimeter. Let us consider a permanent magnet made of 15 per cent. cobalt steel. This material has a coercivity of about 185 gilberts per centimeter. If the air-gap of the electrodynamic loud speaker for which the magnet is intended has a length of 0.17 centimeters and an average area of 4 square centimeters, a magnet that will provide a field of 12,000 gauss in the air-gap can be made in a length of about 20 centimeters. This is approximately one-third the length that would be required were the magnet made of tungsten steel instead of 15 per cent. cobalt steel, with the very considerable added advantage that because of its shorter length leakage flux may be considerably reduced. It is the necessity of reducing leakage flux to smaller values than are generally obtained that may be the deciding factor regarding the possibility of ever producing an entirely satisfactory electrodynamic loud speaker with a permanent magnet. The use of high coercivity steel and the design methods for magnetic circuits which we have just discussed may be an aid in accomplishing this important result.

Short-Wave Journal

The only journal devoted to short-wave reception exclusively is the organ of the International Short-Wave Club, Klondyke, Ohio. A. J. Greene is running the organization and those who are interested in joining the club and receiving the publication may write directly to Mr. Greene. The present fee is \$1 per year. Two copies of the official organ of this club have been received by RADIO BROADCAST and the amount of timely data on the ever-changing short-wave spectrum is surprising. Those who are interested in reading reports of what is going on in the short-wave field will find the publication invaluable.

TRICKS WITH SET TESTERS

(Continued from page 278)

In order to test sets using 224-type tubes an adaptor is necessary. Fig. 2 shows the wiring scheme. The author used Pilot type 215 sub-panel sockets, which nest right into a tube base if the ridge on the socket base is filed away. The adaptor end, "A," fitted on the diagnoser test plug, is inserted in the set. The tube is inserted in end "B" which in turn plugs into the diagnoser socket. The adaptor leads are connected as in Fig. 2. Readings are taken in the same manner as with three-element tubes. The switch shown between the 500-volt one and the 100-volt one in the diagram (Fig. 1) is the one that is pressed for measurement of screen-grid voltage.

The Oscillator

The oscillator has proved itself to be a tremendously useful component of the diagnoser; in fact in a great many instances it has been found possible to locate the trouble in a receiver without the aid of anything else. It is a great help in neutralizing sets and it furnishes an easy means of checking the overall sensitivity of a set. For example, the average loop-operated set will pick-up the signal from the oscillator at a distance of 20 feet, and if the set under test does this but fails to bring in stations properly, the indication is very definite that the receiver is being operated in a shielded location. It is also particularly useful in checking the antenna-ground systems of receivers. By coupling the oscillator closely to a concealed indoor antenna, for instance, it is possible to determine the exact point of a break in the wire. A frequent trouble is the breaking of a rubber-covered lead-in wire inside its insulation, or the shorting of a lightning arrester, and in such cases the diagnoser oscillator locates the faults easily.

With the oscillator it is also possible to tell quickly whether the trouble is in the set proper or in the pick-up system; a determination that otherwise often requires considerable time. It is useful as a means of testing the sensitivity of loud speakers. A bit of experience will enable one to know what volume to expect from a loud speaker when there is sufficient coupling between the oscillator and the set to cause slight overloading of the power tube as evidenced by a plate milliammeter. It is helpful in aligning tandem condensers by noting when maximum deflection occurs on a detector plate circuit milliammeter as the condensers are tuned to resonance with the oscillator. Loose coupling should be used.

The plane of the radiated wave from the oscillator is parallel to the front and back of the diagnoser carrying case. By rotating the carrying case and thus varying the coupling to the set, the oscillator signal as reproduced by the set can be made inaudible at the position of minimum coupling and then brought up to tremendous volume by turning the carrying case a couple of inches.

Table 1

$\frac{V_1}{V}$	K	$\frac{V_1}{V}$	K
0.025	38	0.44	2
0.035	28.5	0.47	1.8
0.05	19	0.5	1.7
0.08	12.5	0.55	1.5
0.1	9.8	0.6	1.3
0.13	7.6	0.64	1.2
0.15	6.5	0.7	1
0.18	5.4	0.75	0.9
0.2	4.9	0.8	0.7
0.23	4.2	0.85	0.6
0.26	3.7	0.89	0.5
0.29	3.2	0.95	0.3
0.32	3	0.97	0.25
0.35	2.7	0.98	0.2
0.39	2.3	0.99	0.14
0.42	2.1		

SM

Here's a New Amplifier With a Wallop You'll Never Forget!

The New S-M 692

Power, and more power—more gain than you ever imagined could come out of a three-stage amplifier. Tone quality—a flat curve (within 2 DB) from 60 to 12,000 cycles—within 4 DB from 44 to 13,000 cycles. Set one up—try it—and you'll know why we feel so proud of it!

You'll notice the difference in the "highs"—the usual falling-off around 6,000 cycles simply doesn't start till up around 11,000. Voltage amplification totals 4,000—three times the usual three-stage total! With proper input transformer there is plenty of gain—as high as 90,000—even for "distant" microphone pickup—or 20,000 from a standard phonograph pickup. High resistance input—operate the 692 out of any source of impedance up to 100,000 ohms. Operate it directly into any speaker system—sixteen combinations give output impedances from 8 to 125 ohms—eliminating any possible distortion in speaker transformer.

Test the 692 just once on your oscillator—and you'll use it thereafter as a standard to test your speakers!

Tubes required: 1—'24, 1—'45, 2—'50, and 2—'81.

Price, completely wired, less tubes, \$147, net.

And the S-M 712—the Ideal Tuner

Just the radio tuner you've been looking for as a feed for that power installation. And what a tuner! All-electric, single-dial (no verniers), pre-selector, power detector, battleship shielding cabinet, individually shielded r.f. coils, and all r.f. circuits individually by-passed and isolated—making the 712 absolutely stable and free from oscillation. And it's absolutely guaranteed to out-distance and out-perform all competition regardless of price.

Tubes required: 3—'24, 1—'27. Wired, less tubes, \$64.90 net. Parts total \$40.90.

The 712 requires separate power supply (2½ volts A, 180 volts B) if used with 692 amplifier. Or S-M 677 amplifier ('45 push-pull, 2-stage) supplies all ABC power required; price, \$58.50 net.

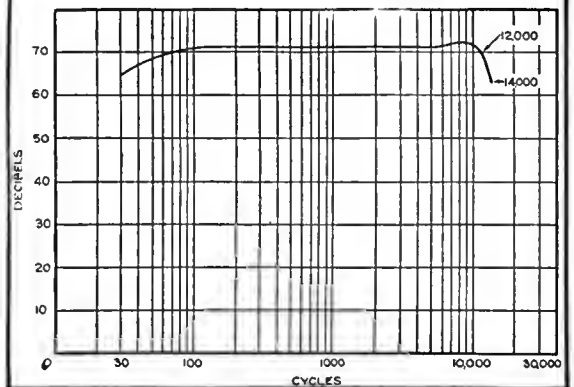
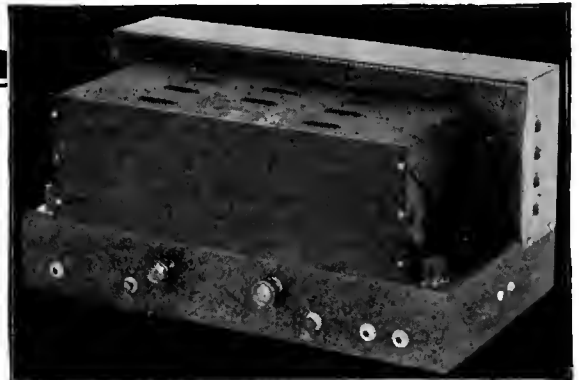

Curve of 692

This curve was not taken at plates of output tubes, but includes output transformer. If input transformer of the speaker is removed, curve shows frequency characteristic as fed direct to speaker.

The S-M 735—Short-Wave "Bearcat"

The first all-electric short-wave set on the American market, the S-M 735 is easily the "bearcat" of them all. Four plug-in coils cover a wave-length range including both amateur and American and foreign short-wave broadcasting (16-6 to 200 meters). Two extra coils extend the wave-length range to cover all American broadcasting. The 735 presents astonishing quality in a remarkably inexpensive receiver. Price, wired, less tubes, \$64.90. Parts total \$44.90. Tubes required: 1—'24, 2—'27, 2—'45, 1—'80.

The Radiobuilder, a monthly publication telling the very latest developments of the S-M laboratories, is too valuable for any setbuilder to be without. Send the coupon for a free sample copy, or to enter your subscription if you want it regularly.

Over 3,000 Authorized S-M Service Stations are being profitably operated. Write for information on the franchise.

SILVER-MARSHALL, Inc.
6403 West 65th Street Chicago, U. S. A.

- Silver-Marshall, Inc.
6403 West 65th Street, Chicago, U. S. A.
- Please send me, free, the latest S-M Catalog; also sample copy of The Radiobuilder.
- For enclosed ----- in stamps, send me the following:
- \$6 Next 12 issues of The Radiobuilder
 - \$1.00 Next 25 issues of The Radiobuilder
- S-M DATA SHEETS** as follows, at 2c each:
- No. 3. 730, 731, 732 Short-Wave Sets
 - No. 4. 255, 256, etc. Audio Transformers
 - No. 6. 740 "Coast-to-Coast" Screen Grid Four
 - No. 7. 675ABC High-Voltage Power Supply
 - No. 8. 710 Sargent-Rayment Seven
 - No. 9. 678PD Phonograph-Radio Amplifier
 - No. 12. 669 Power Unit
 - No. 14. 722 Band-Selector Seven
 - No. 15. 735 Short-Wave "Bearcat"
 - No. 16. 712 Tuner (Development from the Sargent-Rayment)
 - No. 17. 677 Power Amplifier for use with 712
 - No. 18. 772 DC Band-Selector
 - No. 19. 692 Amplifier

Name -----

Address -----

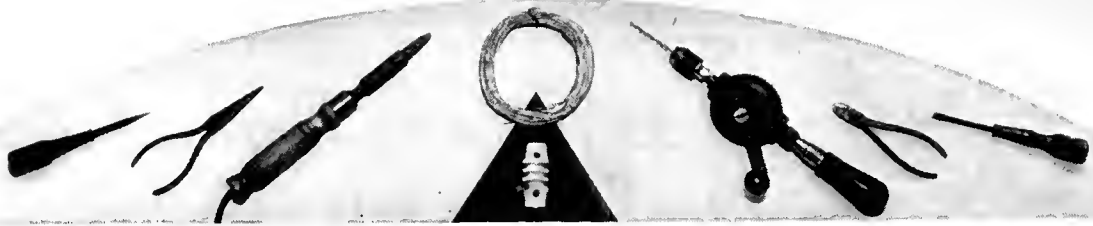

THE SERVICEMAN'S CORNER

Artificial QRN

Artificial static is a problem that confronts the serviceman much more often than he realizes due to the difficulty of distinguishing between artificial strays and natural static. The almost universal test of disconnecting the antenna, and convincing oneself that, if the sound stops, it is bona fide static, "is all wet." Disconnecting the antenna, particularly if there is a station tuned-in, will lessen the effect of all extraneous sounds, even those emanating from the receiver and power supply itself. The only real way of discriminating between artificial and atmospheric static, is by comparing reception between the offending receiver, and a set located in a district known to be free from power leaks and other forms of man-made QRN. Once a determination has been made, the notes below will be helpful:

TRACING ELECTRICAL INTERFERENCE

C. Washburn, Jr., radiotrician of Florida, veteran contributor to the Serviceman's Corner, and associated with the Electric Distribution Department of the City of Jacksonville, sends us the following notes:

"A few weeks ago WJAX, the municipal station of Jacksonville, Fla., was authorized to hire a man for the express purpose of tracing down electrical interference throughout the city. Up until that time this work was done by Superintendent F. H. Koerber, of the City Electric Distribution Department, assisted at different times by other members of the department, among them myself.

"The first trouble of any great magnitude to be run down was radiation from the mercury-arc rectifier tubes. This interference went out on the street-lighting circuits all over the city. The rectifier tubes are used with constant-current transformers to supply high voltage d.c. to the street lights. This was referred to the General Electric Company who submitted the design of a coil to be constructed and connected to the offending tubes, and this practically eliminated the trouble from this source.

TREE GROUNDS

"The principal trouble we have encountered is tree grounds on the street-lighting wires carrying up to 7000 volts. Where a limb touches one of these wires arcing takes place and interference

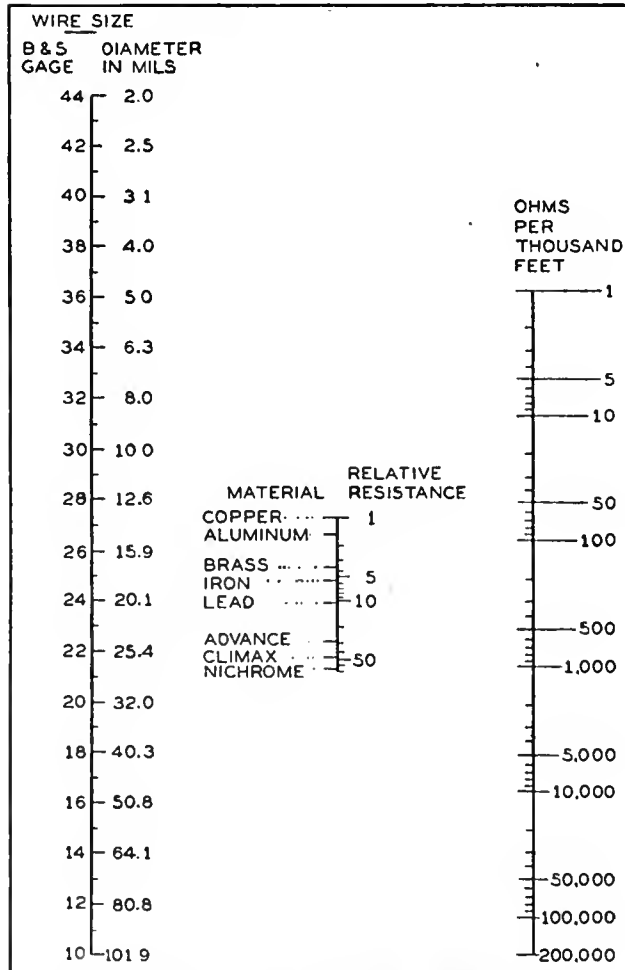

A useful chart prepared by the Radio Corporation of Pennsylvania. An extended straight edge intersecting the kind of wire and the size of wire will indicate on the right-hand scale the resistance per 1000 feet.

is transmitted all over the circuit and is also induced in parallel wires which may carry it into sections away from the original area.

"Contrary to many writers, we have not been able to locate these troubles

fixture we used a Radiola III, with a short antenna. The lamps were about 150 feet apart yet a superheterodyne would not distinguish the one causing the trouble but the Radiola III indicated a louder response

for one than the others when the antenna pole was held up to the lamps. However, the Radiola III is not sensitive enough for ordinary use.

"In conclusion I would say that it takes great persistence and patience to run down these troubles as they do not seem to follow any consistent theory."

GUILTY STREET LIGHT

James A. Robinson, radiotrician of Methuen, Mass., and a
(Continued on page 286)



The Pilot Radio and Tube Corp. is owner of the first radio service plane. Their flying laboratory has been fitted for answering rush service calls on public-address and talking-movie apparatus.



YOU NEED SELF-EVIDENT QUALITY TO SATISFY YOUR CUSTOMERS

Today's critical buyers want the facts before they buy. Show them, with these simple tests, that Arcturus Blue Tubes give exceptional service in every radio set . . .

Here are three tests that accurately measure the merit of any tube.

You can easily make these tests, in a few minutes, in your own store. When you do, you definitely answer three questions about tubes that your customers are asking:

"How quick do they act?"

Ask your customer to hold a watch on any set equipped with Arcturus Tubes. There's the program in 7 seconds.

"How clear is the tone?"

Let your customer listen to the clear, pure tone that is characteristic of Arcturus Blue Tubes. There's no annoying

hum, no outside noise, to mar the smooth reception of any station.

"How long do they last?"

Show your customer, on the meter, that Arcturus Tubes withstand exceptional overloads. This kind of stamina has given Arcturus the world's record for long life.

These three Arcturus tests convincingly prove Arcturus' superiority. Thousands of Arcturus dealers and hundreds of thousands of Arcturus users know by actual comparison that Arcturus performance is unmatched by any other tube on the market today. If you have not checked Arcturus quality ask your jobber for a demonstration. See why Arcturus is the fastest growing tube in the radio industry.



7 seconds by your customers' watch! That's how fast programs come in when Arcturus Tubes are used.



Clear, pure tone, free from hum, is a certainty when sets are equipped with Arcturus Tubes.



Exceptional ability to withstand overloads, easily proved on your meter, explains the long life of Arcturus Tubes.

ARCTURUS RADIO TUBE COMPANY
NEWARK, N. J.



ARCTURUS

Quick-Acting

RADIO TUBES



The Aldrich Radio Service, Minneapolis, make their service wagon do double duty—advertising and transportation.

(Continued from page 284)

Radiola dealer, has had similar trouble with street lamps. He writes:

"A trouble breeder is the street light. While going over a Radiola No. 62 for noises of an intermittent variety I was unable to locate any defect. By chance I was facing the window at the time the street lights went on. The street light in front of this house is the regular Mazda variety. As soon as the street light began to glow a regular barrage of noise came through the loud speaker which disappeared when the street lamp had warmed up. For some time I watched this phenomenon, and at times the light would flicker with an accompanying series of sputters in the set.

"Another trouble of this type I noticed at a Legion whist party where I had installed a Radiola 66. On the stage with the radio there were a number of lamps to be used as prizes for the winners. Upon lighting the lamps the radio had to be shut off until we found the trouble—a lamp with a loose filament."

245 Tubes in Radiolas

Greater undistorted output can be secured from many receivers by substituting the 245-type power tube for lower power types, such as the 210 or the 171. The changes necessitated are those providing for the correct A, B, and C potentials. The correct filament potential may be secured either by placing a resistor in the 7.5- or 5-volt winding, or by switching the filament leads over to a 2.5-volt winding. As a rule nothing can be done about stepping up the B voltage, and when the C bias is secured through an IR drop, the C voltage generally adjusts itself to approximately the correct potential.

RADIOLA 41

The only circuit change is the addition of a resistance in series with the 7.5-volt winding to reduce the filament voltage to 2.5 volts. The changes necessary are indicated in Fig. 1. They are:

1. Fasten an Electrad 3-ohm B resistor to the edge of the baseboard directly above the power pack.
2. Disconnect one of the yellow filament leads from the power pack.
3. Connect this lead to one terminal of the 3-ohm Electrad resistor. The remaining resistor terminal connects to the binding post on the power pack to which the yellow lead was previously connected.

RADIOLA 33

A noticeable improvement in volume and quality of reproduction can be obtained in Radiola 33, 110-volt, 60-cycle, by substituting the 245-type tube for the

171A. To use the 245-type tube in place of the 171A-type tube the following wiring changes are necessary in the socket-power unit only:

1. Unsolder the two red leads attached to one terminal of the filter condenser

Pictures often speak louder than actions. Psychologically we are more interested in what the other fellow has than in what he does. In this connection "The Serviceman's Corner" is particularly interested in photographs of service equipment, from complete laboratories and shops to test sets—from service staffs to individuals. Photographs of unusual installations and service jobs will also be most welcome on these pages.

We shall pay an attractive price for service stories accompanied by photographs, and in many instances we can use photographs alone.

—THE EDITOR

bank. Solder the two leads together and tape up securely.

2. Solder a wire to the condenser bank terminal just left and connect the other end of the wire to the filament terminal

of the 280-type tube socket having two yellow leads.

3. Unsolder the two green leads running from the receiver chassis (filament 171A) at their connection to the centertapped resistor. Connect these two green leads to the outer terminals of the centertapped 227 resistor.

4. Unsolder the three leads connected to the center tap of the centertapped 227 resistor. Solder and tape these three leads together.

5. Solder a jumper between the two center contacts of the 227 and 171A centertapped resistors.

The above arrangement requires no additional parts. The grid bias is slightly high for the available plate voltage, although by reducing the bias to standard specifications no material change is noted in the output. With the changed connections the 245-type tube is operated on a plate voltage of 165 volts, a plate current of 18 mA., and a grid bias of 34 volts.

The power transformer under test for eight hours with this conversion showed no appreciable increase in temperature.

RADIOLA 60

The Radiola 60 may be adapted for use with the 245-type tube in the following manner:

1. Remove the Radiola 60 S.P.U.
2. Remove the two green filter reactor leads from the condenser bank and tape them up, being sure that they are soldered together.

3. Provide a small piece of insulated wire and connect one end of it to the condenser bank terminal to which was previously connected the green leads from the filter reactor. The other end of the lead connects to one of the rectifier socket filament contacts—the socket contact having the single yellow lead already connected is most convenient.

4. Replace the S.P.U. in the cabinet. Reconnect the leads from the receiver assembly to the S.P.U. terminal strip in the normal way except that the two green leads that formerly connected to terminals 8 and 9 are now brought to the two blue leads already connected.

The Radiola is now returned to normal operation except that a 245-type tube is used in place of the 171A.

Electrically the change is to place the 2-mfd. condenser connected between the center point of the two filter reactors and minus B to the filament of the 280-type tube and minus B. The change at the terminal strip places the 245-type tube on the same filament winding as the 227. No drop in the voltage of this winding was noted with the increased load.

The change of the condenser increases

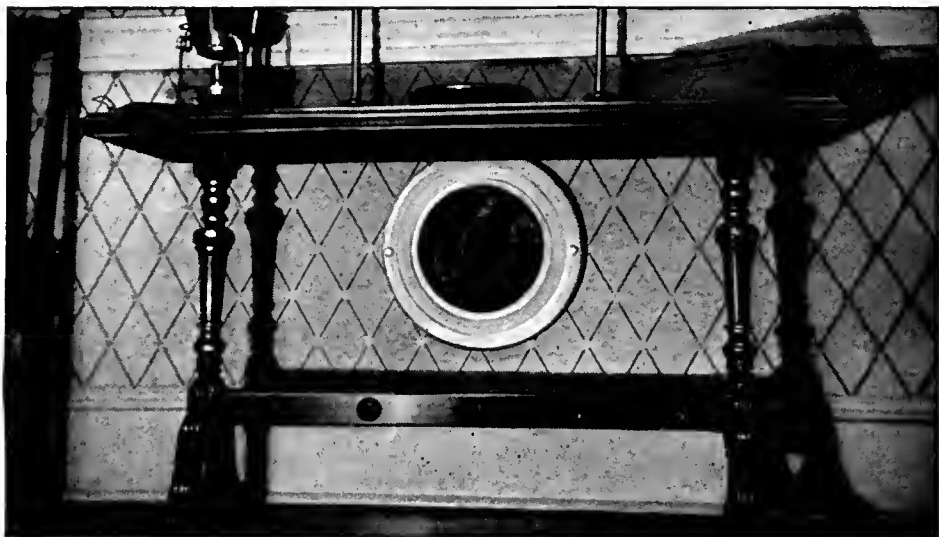

C. Heyd, Milwaukee, Wis., camouflages an electrodynamic loud speaker in a neat installation job. The loud speaker is mounted against a partition between the pantry and the living room, and is hidden by the table.

the initial rectified voltage from the 280-type tube by about 60 volts which causes the 245-type tube to have a plate voltage of 200, a grid voltage of 40, and plate current of 21 milliamperes. The second detector plate voltage is also increased to about 200 and the grid bias to 25, thus providing sufficient output to obtain the desired increase from the 245-type tube. The plate and grid voltages to all the other tubes are increased about 15 per cent. but are all within limits for the tubes.

Points on Installation

Adjusting Line Voltage: H. J. HALSTRUCK, of Philadelphia, Pa., suggests an old but good method of either raising or lowering the line voltage for a.c.-operated

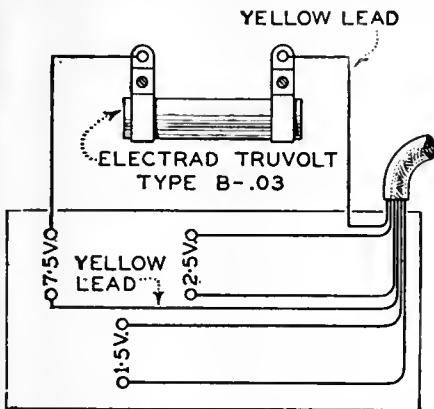

Fig. 1—A simple method of rearranging the Radiola 41 for operation with the 245-type power tube.

receivers, where the variation from normal is fairly constant.

"An efficient and inexpensive method of lowering or raising the line voltage to a.c.-operated radio sets is shown in Fig. 2 (page 289). A Jefferson bell-ringing transformer is interposed between the line and the load as shown. Then, by connecting the two leads to the secondary terminals of the transformer in either of two ways, variations from the line voltage are effected. The effect is that of an auto-transformer with a tapped primary.

"Two advantages of this method over inserting a resistor in the line circuit in order to reduce voltage are: first, that the voltage regulation with various drains is considerably better, and second, that there is no heat dissipation of energy.

"The secondary of the bell-ringing transformer will carry up to one ampere continuously, equivalent to approximately a 110-watt drain. In order to keep the secondary binding posts of the bell-ringing transformer at low potentials, the bottom lead of Fig. 1 should be made the 'hot' side of the line. (Or the transformer can be suitably inclosed.)"

With the two windings connected so as to assist each other, this arrangement can be employed to increase the voltage output of a B-power device.

ANTENNA INSTALLATION

"I am chief serviceman for a concern operating three large stores in central Nebraska.

"In installing radios we put our antennas around the eaves of a house in a good many cases. The split knobs are often driven into the metal roofing cornices or edges and the antenna wire is put on the cross sections of the knob. If the wire touches the nail and the metal roofing strip supports the drain pipes, which in turn touch the ground, you can readily see the result is an antenna that is a ground.

"This type of antenna is very popular
(Continued on page 289)



New!

the PF 245 A

AmerTran Power Transformer

Continuing its progress in the development of power transformers for all radio receiving sets the American Transformer Company announces the perfection of the new type PF 245 A. This new power transformer operates a radio receiver equipped with 2½ volt heater for heater type A. C. tubes and 2½ volt filament for a power tube (UX245 or CX345) which closely approaches the 210 in undistorted watts output.

The AmerTran Power Transformer Type PF 245 A is designed for a 60 cycle 115 volt line source, and has a continuous rating of 100 VA. with primary taps for 100—108—115—120 volts. A four point radial switch regulates the operation for different primary voltages. There are five secondary windings. Because of its lower maximum voltages, all secondary connections terminate in solder lugs attached to a bakelite terminal board.

This new, heavy duty power transformer is compact, sturdy, beautifully machined and mounted in cast iron end clamps provided with mounting feet. Like all AmerTran Transformers the PF 245 A is built to deliver sufficient excess voltage for maximum requirements.

Fill out and mail the coupon for AmerTran Bulletin No. 1088 giving complete description of the PF 245 A Power Transformer.



AMERTRAN

TRADE MARK REG. U.S. PAT. OFF.

AMERICAN TRANSFORMER CO.
Builders of transformers for over 29 years
178 Emmet St., Newark, N. J.

List Price \$22
East of the Rocky Mountains

AMERICAN TRANSFORMER CO., 178 Emmet St., Newark, N. J.

Please send me complete information on the new PF 245 A Power Transformer.

Name.....

Address.....

R-B-3-30

CROSLEY MODELS 40-S, 41-S, 42-S, AND 82-S

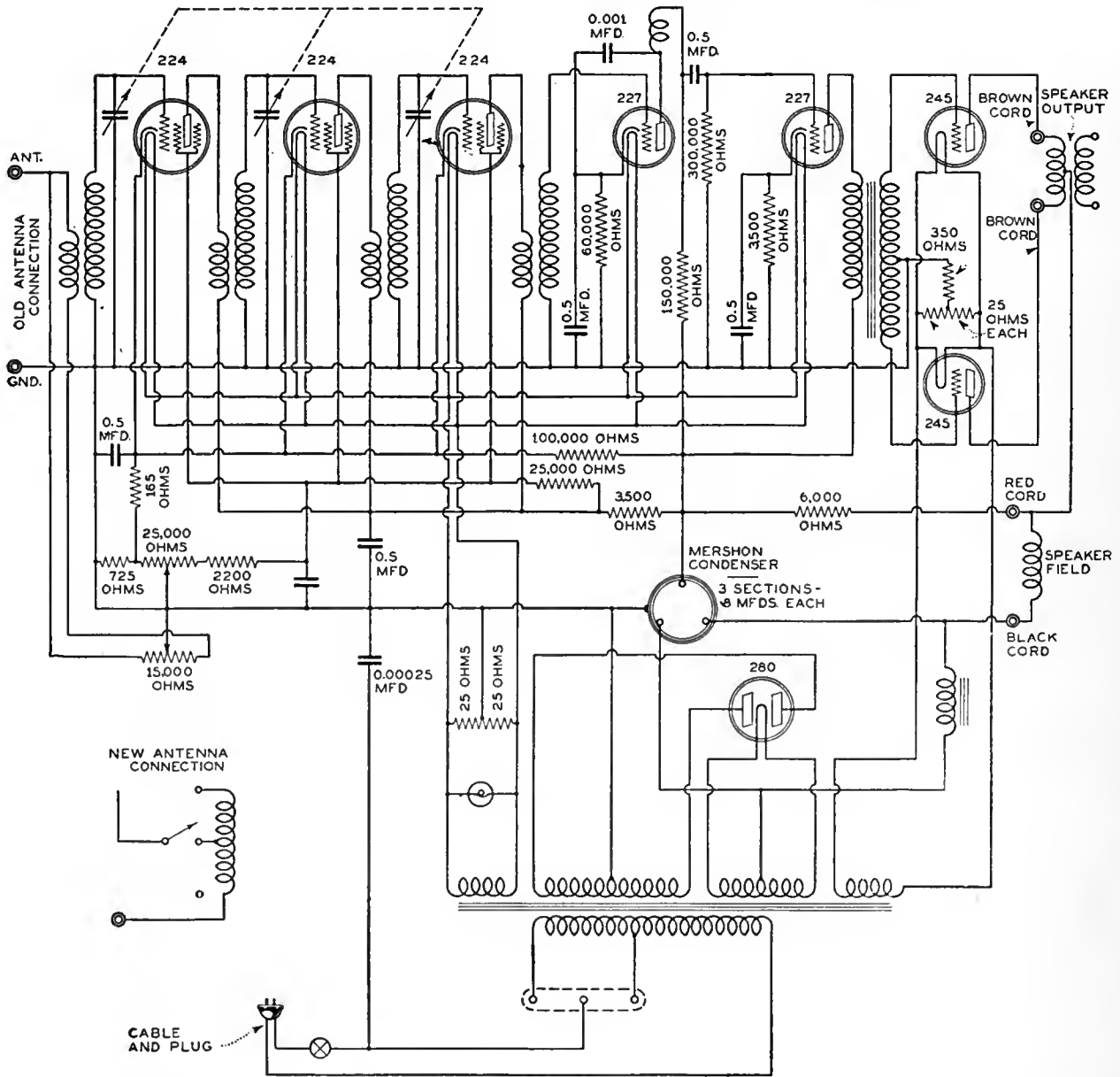

THIS RECEIVER incorporates an eight-tube (including rectifier tube) circuit which employs three stages of tuned radio-frequency amplification, an untuned detector stage, and two stages of audio-frequency amplification, the second of which is a transformer-coupled push-pull stage. The first audio-frequency stage is resistance coupled to the detector stage. Screen-grid tubes are used in the radio-frequency stages.

Receivers having serial numbers prefixed with "GC", "GCA", "GCB", or "GCC" have volume controls composed of two rheostats operated simultaneously. One of these is shunted across the antenna coupling coil primary so as to regulate the strength of signal passing through this coil. The other is used to control the potential of the screen grids in the radio-frequency tubes. Receivers of serial numbers other than above have a volume control consisting of but one rheostat, controlling the potential of the screen grids.

The filament supply for the heater-type tubes (that is, the 224-type tubes used in the radio-frequency stages, and the 227-type tubes used in the detector and first a.f. stages) is obtained from a winding on the power transformer. A 50-ohm potentiometer is shunted across the filament supply leads for these tubes, and the middle tap of the potentiometer is connected to the chassis. The dial light is also shunted across these leads. The filaments of the 245-type output tubes are supplied from another winding on the power transformer. The 50-ohm potentiometer shunted across these leads has its mid-point connected through an 850-ohm resistance

to the chassis. A third winding on the power transformer supplies current to the filament of the 280-type rectifier tube. The high potential plate supply taps on this winding.

A center-tapped high-voltage winding on the power transformer supplies power to the plates of the 280-type tubes. Each end of this winding is connected to one of the plates of the 280-type rectifier tube, so that full-wave rectification is obtained. The tap of this winding is connected to the chassis, which thus acts as the low-potential side of the plate supply. As stated above, the high-potential lead of the plate supply is connected to the transformer secondary supplying power to the filament of the 280-type rectifier tube. This lead is connected through

no iron-core choke coil to the "Black" terminal on the receiver. Two sections of the Mershon condenser are connected to the terminals of the choke coil so that the condenser and choke act together as a filter system. When the Dynacoil loud speaker is connected to the receiver, its field coil is placed between the terminals marked "Black" and "Red." Thus the entire plate current from the high-potential lead of the plate-supply circuit passes through the field of the Dynacoil. The plate supply for the two 245-type output tubes is obtained through a connection inside the Dynacoil loud speaker from the field coil of the loud speaker to a mid-tap on the primary side of the built-in output transformer.

READINGS WITH JEWELL ANALYZER MODELS 198 AND 199

Type of Tube	Position of Tube	Tube		Readings With Plug in Socket of Set and Tube in Tester							
		Out		A Volts	B Volts	C Volts	Cathode-Heater Volts	Normal Plate mA.	Plate Grid Change Test	Plate Change mA.	Screen Grid Volts
		A Volts	B Volts								
224	1st R.F.	2.60	180	2.40	175	1.5	1.5	1.5	4.0	2.5	70
224	2nd R.F.	2.60	180	2.40	175	1.5	1.5	1.5	4.0	2.5	70
224	3rd R.F.	2.60	180	2.40	175	1.5	1.5	1.5	4.0	2.5	70
227	Det.	2.60	100	2.45	100	12.0	12.	0.2	0.3	0.1	
227	1st A.F.	2.65	220	2.45	180	15.0	12.	4.0	5.0	1.0	
245	2nd A.F.	2.55	265	2.30	240	48.0		26.0	30.0	4.0	
280	Rect.	5.60		5.00				100.0			

Line voltage = 117.5. Set on high voltage tap. Volume control position maximum.

(Continued from page 287)

and a little care on the part of the serviceman will be a worthwhile ounce of prevention."

E. A. SHERMAN, Hastings, Nebraska.

SHORT ANTENNAS FOR S-G SETS

"An antenna longer than 60 feet with sets using two or more screen-grid tubes is undesirable. After installing an AK-55 with a short antenna it could pick up both coasts any night. A few weeks later the customer came into the store with the complaint that the music was distorted on low volume. Riding up to the house, I noticed an antenna much longer than

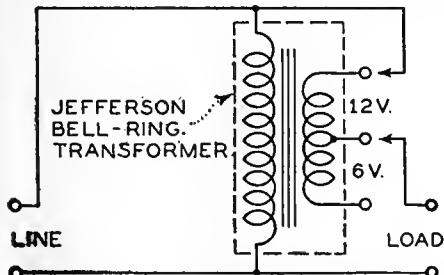

Fig. 2—A somewhat familiar but always practical method of compensating a consistent line variation.

I had installed. Nothing was wrong with the set. I put a condenser in series with the antenna and the distortion cleared up." WALTER STRAUSS, JR., W9CMX, Chicago.

Getting Acquainted With AK

Defective Resistors: WALTER STRAUSS, who specializes in Atwater-Kents, contributes the following:

"I am one of those fellows who are loath to drag the set analyzer from the car when an Atwater-Kent set is a bit below par. All the sets below the AK No. 55 employ glass voltage-dividing resistors in the power pack, and if the first a.f. tube is pulled out and put in without a click, it is a reasonably sure sign that the first a.f. resistor is gone. To make sure I put a new a.f. resistor across the terminals and if music comes through, then that's the one."

MODEL 55

A serviceman in Eutaw, Alabama, bids us beware of high-voltage shorts:

"If the set hums see if the rectifier tube shows a blue glow. If it is dead, look for a burned-out filament. In either case remove the base cover from the set and inspect the left-hand or outside plate lead—it may be shorted or arcing to the filament prong on the same side of the set. This will not show up in a continuity test if it is only arcing over. The trouble is caused by rough handling in nearly all instances."

SERIES CATHODE RESISTORS

An Atwater-Kent dealer in Mount Vernon, N. Y., keeps the ball rolling: "The last Atwater-Kent we received for servicing was a new one that had just arrived from the factory. The set would work all right for a while then it would burst out in loud crashes. We were at a loss as to the trouble, so we sent it back to the factory. They returned it saying nothing was wrong with it. However, the noise was worse than ever. We suspected the first a.f. transformer, but upon replacing it, no improvement was noted. Then we thought the by-pass condenser was punctured. However, tests showed nothing wrong here. I happened to be tapping around the set when I hit the series cathode resistor (the set was turned on and removed from the cabinet). The crash was heard in the loud speaker. When we re-

(Continued on page 291)

PROOF

In order to meet the acid test of big theatre sound reproduction requirements, any reproducer must represent the last word in efficiency. The verdict of Mr. E. C. ZRENNER, Sound Engineer of the great Publix theatre interests is overwhelming proof of the satisfaction given by the

Wright-DeCoster Reproducer

Read what Mr. Zrenner says:

WRIGHT-DECOSTER, Inc.
2233 University Avenue, St. Paul, Minn.

January 1, 1930

Gentlemen:—After using several of your Wright-DeCoster speakers and No. 9 horns, I am writing to let you know that they are giving very satisfactory results. Very truly yours,

E. C. ZRENNER, Publix Sound Engineer.



"The Speaker of the Year"



Write for
Complete
Details



Model 117
Junior Console

WRIGHT-DECOSTER, Inc. 2213 University Ave., St. Paul, Minn.
Export Dept.: M. Simons & Son Co., 220 Broadway, New York City
Cable Address: Simontrice, New York

Just as Good for Radio Reproduction

The new home model Wright-DeCoster Reproducer is just the same as the theatre model except volume is reduced to fit home requirements. Manufacturers of radio sets who are satisfied with nothing short of the best will install the Wright-DeCoster in their product.

Are You Experimenting With the New Pentodes?



National Co. Inc. also make a full line of power and filament transformer, and choke coils. Write us for full information to-day, mentioning Radio Broadcast.

Laboratory and home experiments with the new pentode tubes require a reliable source of high voltage. And successful experimentation with the recently announced direct-coupled amplifiers depends on the proper power-supply.

The National Velvet-B Power Supplies, in two popular models, give reliable power tube and accurately adjustable intermediate voltages with minimum hum and a high current output. They are licensed under R. C. A. patents. Priced at \$26.50 and \$39.50 (Less rectifying tube.)

NATIONAL

VELVET — B

POWER — UNIT

NATIONAL CO., INC., Malden, Mass.

Est. 1914

ERLA MODEL 224 A.C. SCREEN-GRID RECEIVER

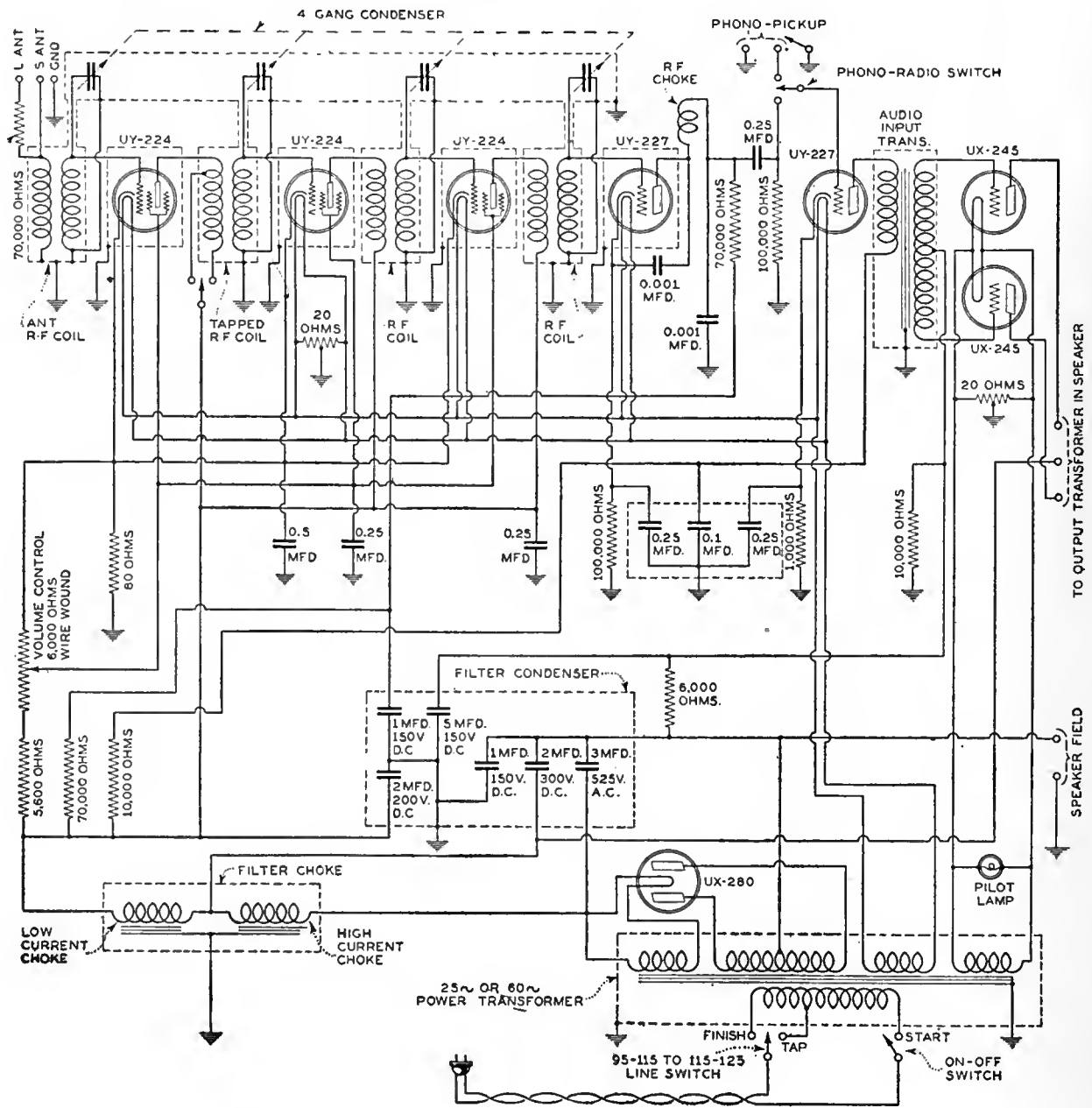

The circuit of this receiver chassis employs three stages of tuned-radio-frequency amplification with four tuned circuits and uses three 224-type screen-grid tubes. The detector is a 227-type tube operated in a grid-bias or plate-rectification circuit. In the first audio-frequency stage a 227-type tube is employed with resistance-coupled amplification. In the output stage two 245-type tubes are used in a push pull. Reference to the diagram will show that two antenna connections are provided. For most purposes the "S. Ant." connection should be used as it provides the greatest sensitivity, but if a very long antenna is used, connection should be made to the "L. Ant." post. It will be noted that the "L. Ant." connection consists of a resistor (attenuator) in series with the "S. Ant." connection. This serves to cut down the signal pickup and consequently the noise level when a very long antenna is used.

The local-distance switch functions to tap the primary coil of the first r.f. transformer. When in the tapped or "local" position the amplification is decreased. This setting is best for most local stations as that proper control of volume is obtained. By moving

this switch to the distance position extreme sensitivity is obtained, but if powerful local stations are tuned-in improper volume control action is obtained for these strong signals tend to overload the screen-grid tubes.

The volume control consists of a 6000-ohm wire-wound potentiometer connected so as to vary the screen voltage on the screen-grid tubes. In combination with this volume control a single-pole, double-throw toggle switch is employed to throw the receiver from "phonograph" to "radio." When the control is turned all the way to the left the input to the resistance-coupled a.f. stage is switched from the output of the detector circuit to the phonograph pick-up

jacks on the rear of the chassis. It will be noted that a small clip-type switch is connected across one of the jacks and the chassis frame. This clip should be connected in this manner when the pick-up unit is not inserted in the jacks, as otherwise a hum will be evident when the volume control is set so that the receiver is in the phonograph position. This hum results from having the input circuit of this first a.f. tube open.

A small toggle switch located alongside of the 280-type rectifier tube is used to tap the primary of the power transformer. The approximate line voltage ranges for the two positions of this switch are shown. It is well to keep this switch in the 115-125-volt position wherever possible.

The loud speaker used with this receiver is of the electrodynamic type and contains in its assembly the output transformer for coupling the output of the two 245-type tubes to the moving coil of the loud speaker. The field of this loud speaker has a d.c. resistance of 1000 ohms and is designed to carry 100 milliamperes. All connections from the loud speaker are made by means of a five-conductor cable and the special five-prong plug which avoids any danger of improperly connecting the loud speaker to the receiver.

AVERAGE VOLTAGE READINGS

Position of Tube	Type of Tube	Fil. Volts (A.C.)	Screen-grid to cathode volts	Plate to cathode volts	Ground to cathode volts	Grid to filament volts
Rectifier	280	4.8 to 5		340 to 360		
2nd A.F.	245	2.4 to 2.5		240 to 250		45 to 50
1st A.F.	227	2.35 to 2.4		90 to 100	4.5	
Det.	227	2.35 to 2.4		60 to 75	6 to 7.5	
R.F.	224	2.35 to 2.4	75 to 80	160 to 170	1.5 to 2	

(The above are based on a line potential of 110 volts and the switch in the 95-115 position, no signal and volume control at maximum.)

(Continued from page 289)
placed the series cathode resistor the noise cleared up."

Sales Dope for Servicemen

BRUCE J. WOODWARD, service chief with Burcher's Battery and Electrical store in Honesdale, Pa., sends the following tip on how to replace antiquated receivers with the help of diplomacy:

"In this territory most of our customers are people of limited means and it is very difficult to sell a new set to a person who already has a set. No matter how obsolete the set may be they will not trade as long as the set will pick up stations. If a salesman calls on a person who has one of these old sets he will be told that the present set is satisfactory and sounds better than many of the new sets. It is a fact that a person will become accustomed to a peculiar kind of distortion and believe it to be perfect reception.

"As soon as something goes wrong with one of these obsolete sets and a serviceman is called in, he has a good opportunity to make a sale without entering into any argument with the customer as to the relative merits of radio sets.

"When I am called in to service an obsolete set and find something wrong which cannot be fixed in a few minutes, I always

take the set to the shop and loan the customer a modern set until the old one is fixed. In many cases this results in a sale.

"To illustrate, here is a typical example—A lady owned a Model 20 Atwater-Kent set. She called me in to service it. I found that her storage battery was worn out. She had electricity so I suggested that she buy an up-to-date electrified receiver. She told me she could not afford a new set and anyway she was well pleased with her old set. I sold her a new battery and forgot the incident. Less than two months later I was called to service the set again. This time I found the by-pass condenser shorted and the 'B' batteries ruined. Without saying anything about a new set I told her how much the job would cost. She said fix it. I told her I was very busy and would not be able to fix it for a few days, but that I would loan her a set while hers was being repaired.

"I brought her a late model electric set, explaining it was much easier and quicker to hook up than a battery set. I showed her how to operate the set and left without giving any sales talk at all. Two days later the lady called the store and said she wished to see the serviceman. I called and sold her the set. She told me she had not dreamed there could be so much difference in radio receivers.

BOOK REVIEWS

PRINCIPLES OF RADIO, By Keith Henney.
Published by John Wiley & Sons,
New York, 1929. 477 pages, 306 illustrations. Price: \$3.50

Speaking as an occasional reviewer of radio books, the opinion is offered that adverse criticism does not necessarily arise from the mean motives which fill the yellow papers and the green magazines. Some books are so badly written that comment must be either adverse or dishonest, and most of us prefer not to lie publicly.

It is, therefore, very pleasant when one is so lucky as to come upon a book which permits speech that is both honest and favorable. The writing of this review of the *Principles of Radio* is accordingly a pleasure.

The author's viewpoint from the laboratory and editorial desk of RADIO BROADCAST seems to have been unusually favorable for he has avoided altogether those standard defects which vitiate the usefulness of nearly all radio books. Thus we are spared the customary platitudes; we need not yawn through a rehash of the wonders of radio, we are spared an introduction, and the preface is 16 lines long. Even more! We are not (this is really very hard to believe) dragged to the edge of the traditional frogpond and made to observe the ritual ripples on its ancient and scummy surface.

Having decided to speak of radio—which is electronic—the author forthwith does so. The electron appears in the second sentence and remains through the entire performance, not in an unseen chorus behind the scenes but as an active member of the cast, along with the rheostat, the ammeter, the tube socket, etc.

Plainly, a moderate amount of well-explained mathematics can replace a huge quantity of talk about radio theory. Most books have instead slunk swiftly through the subject under cover of a thin fog of generalities called a "non-mathematical treatment," or else have solemnly buried the subject past all hope of resurrection under a ponderous mass of obscure calculations. The present book is mercifully free from either extreme. The mathematics are as simple as is expedient. Where it is convenient to show the derivations that

is done; where it is better to show only the final formula as a working tool that is done without apology and with the meaning of the symbols clearly stated, a practice so novel in the troubled literature of the art as to be almost heretical. Furthermore, the same system of electrical units is used throughout the book, the author not finding it necessary to demonstrate either erudition or indolence by the usual unprofitable variety of standards.

The illustrations are numerous, clear, pertinent, and (again your credulity is to be taxed) placed adjacent to that part of the text which discusses them. For this alone many sins could be forgiven, although there is no need.

The problems and examples are alive and not fossiliferous. One meets the UX-227, not the obsolete VT-14 or the obscure P-20. There are a great many such problems and examples, nor are they of the variety sometimes used as filler.

Where there is a curve it relates to something existent, not to the customary unknown or "purely illustrative" device.

'It is hard to express the elevation of the spirit which results from this transfer out of the area of the academic and bygone to that of the actual and existent. Indeed, if adverse criticism were to be offered it would be in the mild form that the title of the book might well have been extended to read "Principles of Radio and their Practical Application."—ROBERT S. KRUSE.

New York-Chicago Circuit

The Universal Wireless Communication Company announced late in January the opening of a New York-Chicago circuit. The New York Office is located at 130 West 42nd Street. Rates are arranged on the same basis as domestic telegraph companies with the exception that the minimum is 15 rather than 10 words.

Service Companies Merge

QRV Radio Service, Inc., 155 West 72nd St., New York City, recently purchased the service business of Rossiter, Tyler & McDonnell, Inc., of 136 Liberty St., New York City. The business and good will of Factory Radio Service in New York City has also been acquired by QRV.

NO [REDACTED]
NOTE [REDACTED]
[REDACTED] CAN
[REDACTED] ESCAPE
Thordarson
POWER ▲ ▲ ▲ ▲
AMPLIFICATION

Realistic reproduction for all occasions . . . and in every circumstance . . . that's what Thordarson's new line of complete Audio Amplifiers means to the listening world. And nothing short of actuality in sound reproduction will be accepted today.

Thordarson Amplification Equipment Means Consistent Audio Excellence

The engineering laboratories of Thordarson . . . with years of research and experience behind them . . . have succeeded in solving the problems of sound reproduction. And with the utmost in manufacturing facilities, the most exacting

specifications are faithfully and efficiently fulfilled.

Why not make use of Thordarson engineering service in your work? We can give you installation suggestions that will make your work easier and more profitable.



THORDARSON
Transformer Specialists Since 1895

THORDARSON ELECTRIC
MANUFACTURING COMPANY
Huron, Kingsbury and Larrabee Streets
Chicago, Illinois, U. S. A. 4416

Extra Money! For Service Men

Extra
Enjoyment
for
Construction
Fans



RETURN COUPON
FOR FREE BOOKLET!

You know dozens of people who cannot (or will not) buy a 1930 receiver, but who will spend a reasonable amount to secure 1930 tone quality. This free booklet tells about the profit possibilities of modernizing old sets with new Pilot transformers.

PILOT RADIO & TUBE CORP.

323 BERRY STREET, BROOKLYN, N. Y.

PILOT RADIO AND TUBE CORP.

323 Berry Street, Brooklyn, N. Y.

Send me without obligation "A 1930 Voice For Old Sets"

NAME.....
ADDRESS.....
CITY.....STATE.....

VOLUME CONTROL IN BROADCASTING

(Continued from page 261)

audible, and, as amplifiers are used on all circuits, it is readily understood that cross-talk becomes a serious factor in transmission over telephone wires.

Experience has shown that the cross-talk level on a circuit is something of the order of minus thirty-five decibels. To express this differently it might be said that if an amplifier having a gain of thirty-five decibels were placed across a dead circuit and its output connected to a loud speaker or pair of headphones, a jumble of cross-talk from adjacent circuits would be clearly audible.

This means, of course, that if we permit the energy level of the program being transmitted over the circuit under discussion to fall to a level of minus thirty-five decibels the jumble of noise and cross-talk in the circuit will be as loud as the program being transmitted at that particular instant. It is necessary, therefore, to maintain a ratio in favor of the program transmitted.

Inasmuch as this cross-talk level varies considerably with open wire circuits, depending on weather conditions, the margin between the lowest levels of the transmitted program and the cross-talk must be kept wide enough to prevent the cross-talk being heard by the radio listener. Cross-talk does not always consist of jumbled conversation and music but very often is induction produced by adjacent power lines, resulting in what is commonly called "line hum."

Total Volume Range

Experience has taught us that if we are to transmit a program over a telephone circuit in a satisfactory manner that we must not permit its minimum energy level to fall below minus twenty-five decibels. Of course, there are cable circuits where this minimum can be dropped to a minus thirty and sometimes minus thirty-five, but this latter condition exists chiefly in cities where underground lead-covered cables are used exclusively. We, therefore, find that the volume variation permissible over a telephone circuit is from plus six to minus twenty-five db, a volume variation of approximately thirty decibels. However, the full range of 30 db cannot be utilized as it is not possible to operate at the maximum level plus six decibels in practice.

To prevent too high a level being transmitted on the telephone circuits, the repeating amplifiers equipped with vacuum tubes will not pass energy levels in excess of plus six decibels peak level. Volume in excess of this merely overloads the vacuum tubes, producing harmonics and distortion. Inasmuch as several hundred of these telephone repeaters are used in the networks of the National Broadcasting Company, a margin of safety must be allowed at the top to prevent overloading on repeaters whose gain setting is such that they may more than compensate the loss introduced by the telephone line. This condition is not brought about by the repeater changing its gain but by the telephone circuit changing its characteristic due to the weather conditions. For instance, when the circuit is lined up prior to a program it may be bright daylight with an intense sun shining on the open wire lines, causing the resistance of telephone circuits to be at a maximum and, therefore, the transmission loss the highest. After sundown, the temperature of these wire lines is reduced materially and some of the transmission loss is removed, bringing up the input levels to all subsequent repeaters on that circuit, thus increasing the output level to a point in excess of the allowable maxi-

mum. Of course these conditions are watched closely and attempts at correction are made while the programs are in progress.

Practical Limits

Experience has taught us that it is necessary to leave a margin between the absolute maximum and the practical operating maximum. Therefore, our programs are transmitted with a maximum energy level of plus two decibels, reducing the possible volume variation that can be transmitted to twenty-seven decibels.

In transmitting a full symphony orchestra whose volume variation is approximately sixty decibels between its minimum pianissimos and maximum fortes, it is absolutely necessary for an experienced control man to reduce the maximum energy level to plus two decibels and raise the minimum energy level to minus twenty-five decibels. This can be done successfully if the volume control man, whose training makes it possible for him to visualize these problems, is assisted by a musical director who can interpret for him the score of the symphonic music several bars in advance of the playing in order that he may smoothly control with accuracy the gain settings of his amplifier.

If this man did not function, the radio audience would listen to a badly overloaded and distorted transmission on the fortissimos and would be unable to hear the minimum pianissimos because they would be over-ridden by cross-talk. This explanation is not written in any criticism of these limitations placed on radio broadcasting by the wire lines, but it is a compliment to the engineers who have made the present facilities as satisfactory as they are for the handling of radio programs. At the present time every effort is being bent to improve these line facilities not only with respect to volume variation that can be handled, but also to widen the band to transmit more bass and more harmonics.

Characteristic Curves

Several curves showing the line characteristics of network circuits will be found accompanying this article and an explanation of the data they contain may be of interest.

The four curves in Fig. 1 show the audio-frequency characteristic of transmission through WEAf, Bellmore. The output curve shows frequency characteristic of the radio transmitter alone which is even from 30 to 10,000 cycles within plus or minus 1 db. This, of course, covers a range of frequencies considerably greater than the average receiver and loud speaker will reproduce.

The second curve shows the characteristic of the telephone line from New York to Bellmore, including the line amplifier at New York and the speech amplifier at Bellmore. It will be noted that there is a slight drop at the lower end which is of no consequence and at the upper end of the curves it will be noted that the telephone line cuts off sharply at 8000 cycles. The telephone line from 711 Fifth Avenue to Bellmore is a cable circuit of latest design and unlike the usual run of broadcast circuits, is passing frequencies from 30 to 8000 cycles. By reference to one of the other curves showing the typical network circuit, a comparison of the two line characteristics may be noted.

The third curve is the addition of the first two curves, showing the radio transmitter and line together.

The bottom curve shows the overall characteristic of the transmission system from the microphone to the air, including all speech input equipment at 711 Fifth Avenue; considering that this includes the entire broadcasting system, a variation of 6 db is still acceptable to the average radio receiver and the average ear, so it

Stop A.C. Noise!

Improve Selectivity!

PLUG in a Falck Claroceptor between wall socket and radio set and eliminate "static" from motors, street cars, telephones and electrical appliances. This new improvement by a pioneer radio parts manufacturer grounds and thus blocks out line interference noise and radio frequency disturbances. Also improves selectivity and distance. Requires no changes in set. Measures just 3½ x 5½ x 2½ inches. Thousands now all over America use the Claroceptor for clearer A. C. reception. Get one right away—at radio parts dealers. Write for descriptive folder.

\$7.50 complete with cord and plug



Falck

CLAROCEPTOR

Built by ADVANCE ELECTRIC CO.
1260 W. Second St. Los Angeles, Calif.
JOBBERs and DEALERs, GET OUR PROPOSITION

can be stated that frequencies between 35 and 7000 cycles are successfully transmitted in this system.

The audio-frequency characteristic of a typical network circuit is shown by the two curves (Fig. 2) representing the red and blue network circuits from New York to Chicago. Considering the length of this circuit, and the fact that it is made up of varying types of transmission facilities and involves a number of telephone repeaters, the frequency characteristic from 100 to 4500 is flat within plus or minus 2 db. This condition, of course, varies somewhat with temperature and weather conditions but in general it is typical of the circuit.

Low-Frequency Cut-Off

Generally speaking, both of these circuits cut off quite sharply at 90 cycles, and, as stated before, this cut-off point varies from day to day within a few cycles as shown by the difference between the red and blue network in the particular curves. Two or three years ago this cut-off at 100 cycles was not noticeable to the average listener but with the advent of electrodynamic loud speakers and amplifiers which will handle the bass in the later radio receiving set models, this loss of frequencies below 100 cycles is now more serious. The cut-off at the upper end in the vicinity of 5000 cycles is extremely sharp but this end of the spectrum is not so serious at this time as most radio receivers cut off quite sharply at 3000 cycles.

Much work is being done by both the Telephone company and the National Broadcasting Company to extend the range of the present telephone facilities to make the general transmission of network circuits comparable with that shown in the curve for the Bellmore circuit.

Fig. 4 shows a typical frequency characteristic of the transcontinental circuit from San Francisco to New York. It will be noted that the added line facilities and the additional repeaters make the cut-off at 100 and 4500 cycles much more definite. Considering that this represents 3000 miles of cross-continent circuits the frequency characteristic over the range transmitted is reasonably stable.

Another Problem

Another factor enters into this problem, and that is the volume variation which the average radio receiver can handle. The more modern sets are now constructed so that they can handle considerably more volume than was possible two years ago, but the problem of background noise brought in by the radio receiver and introduced by the vacuum tubes and the power supply is a limiting factor.

As conditions stand to-day, the average radio set operating at some distance from a radio transmitter has a higher noise level to contend with than that which is found on telephone wires, so that even if greater volume ranges could be transmitted over telephone circuits, the ether medium through which the program must be transmitted eventually, introduces a problem which is not as readily overcome as our first difficulty.

The cure for static and interference by electrical machinery operating in the neighborhood of receiving sets is a further increase in power of the radio transmitter, thus increasing the ratio of signal strength to noise at the listener's antenna.

The first condition we have some control over—that is, the energy levels transmitted over telephone wires to the radio transmitters; but the broadcaster has no control over the manner in which the broadcast listener operates his radio set. All the care taken by broadcasting companies and the telephone companies in maintaining energy levels and preventing overloading in any of the equipment under their control, is completely

offset by the listener when he overloads his amplifier.

Conclusions

I still feel that, perhaps, the real limiting factor which makes volume control necessary is the ether medium and the radio receiver where the margin is even less than exists in telephone circuits. The amplifiers and the radio transmitter in use by broadcasters have been designed so that the volume variation that can be handled by this equipment is as great as that of the symphony orchestra itself. I use the symphony orchestra in this explanation because it probably has the greatest volume range that we have to consider. A jazz orchestra, for example, which plays almost at the same tempo and volume at all times, for dancing purposes, presents no problem. In most cases volume control is not necessary during the playing, as the orchestra maintains its dynamic range within a volume variation of twenty-seven decibels. The diagram on page 261 (Fig. 3) shows the limitations on a decibel scale as compared with the volume variations of a symphony orchestra.

CHARACTERISTICS OF PENTODES

(Continued from page 255)

be representative of the final tube in several respects, there is a step-up of 8 to 1 between the high-voltage grid and plate. Hence any a.c. hum reaching to the high-voltage grid will be amplified by a factor of 8 by the time it gets to the plate. At the same time the superior sensitivity of the tube indicates that hum appearing in the plate circuit of the preceding stage will reach considerable proportions in the loud speaker circuit. For this reason it may be that greater filtering than is now necessary will be required.

Similar experimental tubes are being built by other tube manufacturers. Those made by Champion have been tested in the Laboratory and are not appreciably different from the Arcturus tubes.

Screen-Grid Tube Developments

If another grid will improve a power tube and get rid of secondary emission, tube manufacturers reason that an extra element may improve a screen-grid tube. CeCo has spent considerable time in experimenting with such tubes and some characteristics of such a screen-grid pentode tube are given here (Fig. 5). Table III compares it and present-day screen-grid tubes.

The greater possible amplification from such multi-element tubes is obvious. Whether or not receiver manufacturers prefer to get a lot of r.f. gain per stage or to get the total amplification in several stages is a matter that time only will indicate. At present it seems more economical to use several stages and to get the total amplification by cascading. The problem of shielding a stage in which there is a voltage gain of 100 is different than that of preventing stray fields from a stage in which the gain is only 30 times. On the other hand, the economy to the consumer of operating fewer tubes and the sales value of a physically smaller set may indicate use for this new high-gain screen-grid tube. As an a.f. amplifier tube, it should prove to be quite valuable. It represents a gain of 6 db over present screen-grid tubes.

Tube manufacturers working on power-output and screen-grid pentodes will welcome suggestions from manufacturers and designers of receiving sets. At the same time the Editors of RADIO BROADCAST will welcome communications on this interesting subject.

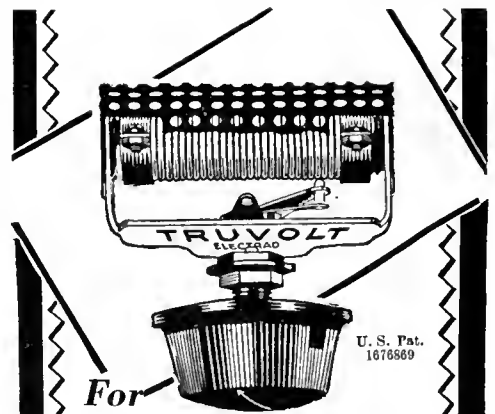

U. S. Pat.
1876889

For

SATISFACTION Sell ELECTRADS

SINCE the birth of radio, the name ELECTRAD on a resistance has stood for highest quality at right prices—the unbeatable combination that spells increased profits and good-will for your parts department.

TRUVOLT

Safest for Eliminators

Distinctly different air-cooled winding gives greater accuracy and longer life. Variable model (illustrated) with knob control and panel mounting. 22 sizes. List \$2.50.

Fixed types have exclusive sliding clip for adjustment of resistance values. Made in all usual sizes.

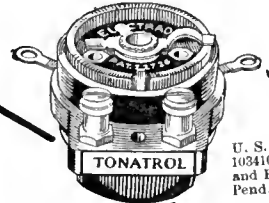

U. S. Pat.
1034103-04
and Pat.
Pend.

TONATROL

The Expert's Choice

The TONATROL line of volume controls is characterized by superior workmanship and longer life. Made in a variety of sizes and resistance values, with or without filament switch attached. List \$1.50 to \$3.00.

Super-TONATROL

For Power Receivers

New type resistance element permanently fused to an enameled metal plate with pure silver floating contact insures smoother action, longer wear and rapid heat dissipation up to 5 watts. 7 types for all usual requirements. List \$2.40 to \$3.50.

175 Varick St., New York, N. Y.

ELECTRAD
INC.

ELECTRAD INC., Dept. RB3
175 Varick St., New York, N. Y.
Please send data on TRUVOLT and
TONATROL Line to
Name.....
Address.....

RADIO

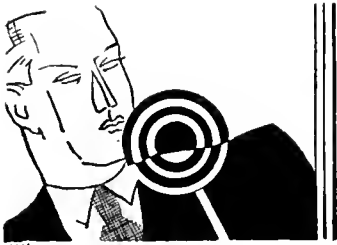

Grigsby-Grunow Paid Huge RCA Royalty

During the eighteen months that the Grigsby-Grunow Company has been in the receiving set business RCA has received \$5,302,879.15 from them, stated Mr. Grigsby before the Senate Commerce Committee recently. Describing the present patent situation as intolerable Mr. Grigsby said that when he accepted the RCA license he understood that RCA enjoyed a complete patent monopoly and that these patents covered every part of the radio receiving set. "This is not true," continued Mr. Grigsby. "We are now paying royalty to three other patent owners and have been sued by five additional companies, claiming infringement of seven patents. In no case has the Radio Corporation protected us against these patents or helped us in the suits which have been filed against us.

"The patent licenses we were thus compelled to take out include one under the RFL patents. We also had to take out a license under the Lektophone patent. This is a patent on the loud speaker cone. When we manufactured our loud speaker under the RCA patents we copied directly the 104-A type of Radio Corporation loud speaker.

"When Lektophone Company charged us with infringement we tried to get some help from the Radio Corporation but they refused to give it because they had taken out a personal license from the Lektophone Company and thus acknowledged the validity of its patents. The radio combine did not take out a license to protect its licensees and so we had to pay additional royalties to Lektophone on the same loud speaker which we are making under the RCA patents.

"We also have a license under the Lowell and Dunmore patents which have recently been upheld in the suit against RCA. Further, to show that the members of the radio combine, individually or as a group, do not own patents covering even standard types of sets we are also being sued at present by the following: Magnavox, Hazeltine Corporation (two patents), Latour (two patents), Federal Telegraph Company (Kolster patent), Edelman, and DeForest. Beside this we have been threatened by at least a dozen other patent owners.

"The distinction between the licensing policy of the radio combine and that of other patent owners is that the combine is seeking to dominate the industry and create a monopoly while the others are simply trying to collect revenue from their patents."

Columbia Finances Improved

"Revenues for the Columbia Broadcasting System in 1929," said William S. Paley, president, recently, "were approximately \$3,500,000. Columbia serves," said Mr. Paley, "71 affiliated stations, is absolutely independent, and depends for its earnings solely on the sale of time for sponsored programs." In 1928 Columbia showed a loss of \$172,655. Prior to January 1, 1928, the loss was \$205,424.

Annual Trade Show and Convention in Atlantic City



The new mammoth \$15,000,000 civic auditorium on the boardwalk at Atlantic City where the Annual Convention and Trade Show of the Radio Manufacturers' Association will be held during the week of June 2. The building is the last word in convention hall construction. It is 350 feet wide by 650 feet deep and provides 85,000 sq. ft. of exhibition space.

Supreme Court Refuses to Act in Radio Patent Suit

The decision of the Circuit Court of Appeals for the Second Circuit in the radio patent case of Wildermuth vs. Hazeltine Corp., No. 532, will not be reviewed by the Supreme Court of the United States, that court on Jan. 13 having denied a petition for a writ of certiorari.

The respondent is the owner of the Hazeltine patent in suit, No. 1538858, covering "grid-circuit neutralization," while the petitioner, a resident of New York, is engaged in the sale of radio broadcast receivers.

The petition for a writ of certiorari pointed out that among the fundamental rules of construction, as related to patents, is the principle that a limitation introduced into the specification to obtain allowance cannot be ignored, and that the patent cannot be interpreted as if such limitation did not exist.

It was the contention of the petitioner that the respondent's patent was deliberately limited to "close coupling," because of rejection by the Patent Office. However, it was pointed out, the Circuit Court of Appeals for the Second Circuit held that the petitioner's "loose coupling" did infringe the respondent's patent, thereby disregarding the disclaimer filed by the respondent.

The respondent took the position in his brief that in describing a particular embodiment of the invention it described ideal conditions—"close coupling" and "substantially equal to unity coupling"—but this was not intended as a limitation of the invention nor of the scope of the patent.

Audio Research Foundation Organized

Oswald F. Schuette, active in the affairs of the Radio Protective Association, is also involved in the Audio Research Foundation, Inc., 134 South LaSalle Street, Chicago. Organization of the group represented is said to be due to the feeling of manufacture of amplifier and associated equipment for radio and sound picture use that mutual protection from the legal thrusts of the American Telephone and Telegraph Company and others of the radio group was a growing necessity. While no membership list is available and none has been announced, C. C. Colby, president, Samson Electric, is chairman of the new organization, J. M. Stone (Operadio) is secretary, and John R. Howell, of Chicago, is executive secretary.

The Foundation intends, it is said, to follow two courses of action, according to *Exhibitors Herald World*, a motion picture trade paper. First they will seek to undermine the validity of basic patents on which such companies as Western Electric are alleged to base their exclusive right to manufacture certain radio and sound system parts. The second method of attack to be adopted by this group will be publicity. This publicity will attempt to show, it was said, that a monopoly in public entertainment exists as far as the use of amplifiers for public address and sound motion work is concerned.

The twelfth RCA tube licensee is the Triad Manufacturing Company, Pawtucket, R. I.

INDUSTRY

New Officers Elected

Dr. Lee DeForest was elected president of the Institute of Radio Engineers and L. G. Pacent of the Radio Club of America, in elections announced during January. Other officers of the I.R.E. are: Colonel A. G. Lee, vice-president; Melville Eastham, treasurer; John M. Clayton, secretary, and Alfred N. Goldsmith, Editor of *Proceedings*. Other officers of the Radio Club of America are: C. E. Maps, vice-president; Joseph Stantley, treasurer, and Willis K. Wing, corresponding secretary. Messrs. Amy, Armstrong, King, Burgard, Sadenwater, Grinan, and McMann were chosen for the Board of Direction.

Sarnoff, RCA Head

David Sarnoff is now president of the Radio Corporation of America at the age of 39. He succeeds General James G. Harbord who has been elected chairman of the Board. Owen D. Young, formerly chairman of the Board, RCA, will become the chairman of an executive committee of the company.

Maine Passes Radio Law

According to *Editor and Publisher*, Harold S. Dockam, radio editor of the *Augusta-Kennebec Journal*, is the author of a radio bill recently passed by the Maine legislature. This act makes it unlawful to operate a radiating receiver.

Personal Notes

W. L. Dunn, formerly chief engineer of the Colonial Radio Corporation, has joined the staff of Spragne Specialties Company as head of the engineering department. He will be in charge of research work.

Arthur T. Haugh, former president of the Radio Manufacturers' Association, has been elected vice-president in charge of merchandising of Valley Appliances, Inc.

Harry A. Beach has been appointed manager of the Radio Department of Stromberg-Carlson Telephone Manufacturing Company. Mr. Beach has been associated with Victor Talking Machine Company for more than twelve years, Brunswick-Balke-Collender Company for three years, and Earl Radio Company for three years.

Three promotions in the plant operation and engineering departments of the National Broadcasting Company were announced recently. G. O. Milne, former operations supervisor, was named New York division engineer; E. R. Cullen, former field supervisor, was named staff engineer of the entire system, and Max Jacobson, formerly assistant to Mr. Cullen, was named field supervisor.

L. Warrington Chubb, manager of the radio engineering department of the Westinghouse Electric and Manufacturing Company has been appointed first assistant to the vice president in charge of engineering of the Radio-Victor Corporation of America, Camden, New Jersey.

D. E. Replogle has been appointed treasurer of the Jenkins Television Corporation, Jersey City.

Henry H. Murray has resigned as manager of the Victor technical service department. As yet no

RCA Radiotron Co. Organized

Effective January 1st the RCA-Radiotron Company, Inc., Harrison, N. J., began to function. This organization has taken over all of the manufacturing, sales, engineering, and research activities in the tube field formerly scattered among the various members of the "Radio Group."

Factories, five in number, are located at Harrison, Newark, Cleveland, and Indianapolis. Total production can be 210,000 tubes daily, 5500 people will be employed, and the buildings provide 1,147,000 square feet of floor space. Warehouses are located in New York, Atlanta, Dallas, Chicago, and San Francisco. The complete roster of officers follows:

President, T. W. Freeh
Vice-President, sales, George C. Osborn
Vice-President, manufacturing, W. T. L. Cogger
Sales Manager, Meade Brunet
Advertising and sales promotion, J. W. Melver

successor to Mr. Murray has been appointed but until further notice J. F. McGarrey will be acting manager of the technical service department of the Victor Division of the RCA-Victor Company, Inc.

F. A. La Baw, formerly general sales manager of the Marvin Radio Tube Corporation, Irvington, N. J., has resigned. He is now sales manager of the Standard Tank and Seat Company, Camden, N. J.

The Atwater Kent Manufacturing Company has announced several important changes in sales personnel: J. W. Hitchcock has been appointed assistant sales manager; George H. Jaud, Northeastern sales manager; J. Harry Hickey, Southeastern sales manager; E. E. Rhoads, Central sales manager; H. T. Stockholm, West Central sales manager; L. M. Willis, Pacific Coast sales manager. Announcement has also been made of the appointment of John McCoy to the position of head of the statistical department to succeed E. H. Kester who has resigned.

Kenneth W. Jarvis, formerly chief engineer of The Sterling Manufacturing Company, Cleveland, Ohio, is now radio engineer with Sears, Roebuck and Company, Chicago, Ill.

The Zenith Radio Corporation announces a change in its factory and production management. Frank A. Whiting has been made general factory manager, George Knott has been appointed production manager. Paul E. Anderson has been named manager of the cabinet factory, and Howard A. Gates has been made chief engineer.

William Lawall Jacoby, president of the Kellogg Switchboard and Supply Company, Chicago, passed away after a short illness at Chicago on January 11th.

L. C. F. Horle, formerly chief engineer of the Federal Radio Corporation, has established his own business as consulting engineer at 50 Church Street, New York City.

Charles M. Blackburn, formerly with the Marathoo Tube Company, has been appointed chief engineer of National Union Radio Corporation.

A. F. Murray, formerly assistant chief engineer of Wireless Specialty Apparatus Company, Boston, has joined the engineering staff of the RCA-Victor Company, Camden, N. J.

Cyril M. Jansky, formerly assistant professor of electrical engineering at the University of Minnesota, has opened an office as consulting engineer in the Munsey Building, Washington, D. C.

The Directors of the Radio Corporation of America at their meeting held recently elected an Executive Committee consisting of the following Directors: Owen D. Young, chairman of the Executive Committee; General James G. Harbord, Chairman of the Board; David Sarnoff, president; Gordon Abbott; Edward W. Hadden; Andrew W. Robertson; James R. Sheffield; Frederick Strauss; and Gerard Swope.

(Continued on page 296)

Radio Entertainment the Latest Service on Trains



Those traveling on the "crack" trains of this country and Canada are no longer out of touch with national events. The difficulties presented by steel cars, electric signals, and myriads of power lines have been successfully overcome and as a result passengers are now able to enjoy radio and electric phonograph entertainment while in route. This picture shows a group listening to a radio installed on the Pioneer Limited, a "crack" train of the Chicago, Milwaukee, St. Paul, and Pacific railroad.

Precision

De Forest Audions are laboratory products of precision—that's why they're better.

DE FOREST RADIO CO.
NEW JERSEY
PASSAIC



de Forest

AUDIONS



R.C.A.-Victor Distribution

Those particularly interested in current activities in the field of distribution found something to think about in the announcement made by E. E. Shumaker, president RCA-Victor Company, late in January. President Shumaker said, "The RCA-Victor Company . . . will distribute its products not only through the distributing channels of the Radio Corporation and the Victor Talking Machine Company, but also through the distributing channels of the General Electric and Westinghouse Companies." Since for the last two years Graybar Electric has been distributing under their trade mark the same chassis as found in the entire Radiola line, this in effect promises that every chassis in the Radiola line this year will be available under Westinghouse, General Electric, Graybar, and Radiola labels. It is understood that the Victor receiver, although made in the Camden plant, will retain its individuality in the same degree as during the selling season just past.



T. W. French,
RCA-Radiotron

Supreme Service Stations

B. F. Dulweber, president, Supreme Instruments Corporation, announces that the following organizations have been appointed authorized service stations equipped with parts and laboratory facilities for servicing Supreme Radio Diagnostics and that they have been appointed authorized service stations.

- Harrison Sales Company, 314 Ninth Ave., North Seattle, Washington.
- Arthur Honeychurch, 682 Mission St., San Francisco, Calif.
- Illinois Testing Laboratories, Inc., 111 West Austin Ave., Chicago, Ill.
- Instrument Service Laboratories, 3645 McRee St., St. Louis, Missouri.
- Professional Radio Service, 429 Penn Avenue, Pittsburgh, Pa.
- QRV Radio Service, 1400 Broadway, New York, N. Y.
- Rubicon Company, 29 N. Sixth St., Philadelphia, Pa.
- Standard Laboratories, 1334 Oak St., Kansas City, Missouri.

Stromberg Buys Patent

Stromberg-Carlson has arranged a working agreement with Blutworth, Inc., of New York, designers and builders of special amplifying and remote-control systems. Stromberg-Carlson, it is understood, secures the rights to all inventions and laboratory work of Blutworth, Inc., prominent among which is the radio remote-control system, developed by T. F. Blutworth and Arthur P. Davis, which is fully perfected and has been in service in the field for several years. Under this agreement Blutworth, Inc., also receives the rights to use certain patents held by the Stromberg-Carlson Company.

Blutworth, Inc., will have the advantage of additional working capital, to meet the demands of a rapidly expanding business. It will also receive the benefit of the Stromberg-Carlson's sales and service organization.

A-C Dayton in Receivership

B. A. Ducasse was appointed equity receiver for the A-C Dayton Company on December 20. The action was requested by practically all of the creditors and approximately 90 per cent. of the stockholders. The receiver will undertake to unloose certain frozen assets and will plan for the continuance and further expansion of the business.

Financial Notes

RADIO CORPORATION: The following dividends were declared for the first quarter of the year 1930:

On the "A" Preferred stock—1½% (87½¢ per share)
On the "B" Preferred stock—\$1.25 per share.

These dividends are payable on April 1st, 1930, to stockholders of record March 1st, 1930.

PERRYMAN: This Company reports sales of \$1,121,016 for 1929, compared with \$672,338 in 1928, an increase of 67 per cent. In the last year the company produced 1,142,939 radio tubes, compared with 437,500 in the preceding year.

SPARKS-WITHINGTON: This company reports for the six months ended on Dec. 31, 1929, earnings of \$1,639,365, equivalent to \$2.40 a share on the 684,606 shares outstanding, against \$2.05 a share on the same basis in the previous year. Current assets were shown at \$5,583,616, with total assets of \$8,254,026. Current liabilities were shown as \$544,680 and surplus as of Dec. 31, 1929, \$3,655,988.

RADIO-VICTOR CORPORATION: Sales of radio instruments, records, and record-reproducing instruments, as reported by

Radio-Victor for 1929, amounted to \$121,000,000. The total exceeds Victor's 1928 business by \$22,600,000, and its best previous year, 1920, by \$16,000,000.



W. L. G. Cogger,
RCA-Radiotron

ZENITH: As of December, 1929, cash on hand \$1,165,516. January quarterly dividend not declared. To conserve cash position. Factory production of receivers in 1929 twice as large as any previous year. On December 10, 1929, manufacture of Zenith "50" line of receivers stopped with no manufactured inventory on hand in December. New "60" series production begun January 2nd. Zenith dealers total 6000, distributors 55.

GRIGSBY-GRUNOW: Report for six months ended November 30, 1929, showed net income, after deducting depreciation, Federal taxes, and all other charges, of \$3,989,717, equal to \$1.99 per share on the 1,997,897 shares of no-par-value stock outstanding. Total assets as of November 30, 1929, equal \$35,537,128 compared with \$10,093,418 for previous year. Cash in hand was \$3,387,031. Production reached in October, 6000 sets and 65,000 tubes per day. The radio tube business of the company will shortly be transferred to a separate corporation, operating under an RCA license. In 1930 Majestic will enter the electric refrigeration field says President Grigsby: "Because of the fact that this field is opposite in its seasonal aspect to radio and the adaptability of the company's equipment to its manufacture we are optimistic as to the results."

Production Notes

HIY-GRADE: Daily capacity of 10,000 tubes; will soon be increased to 15,000, it was announced late in December.

NATIONAL UNION: President Chirelstein states National Union plans to sell more than 15,000,000 tubes during 1930.

QRV Radio Service, Inc., formerly located at 1400 Broadway, New York City, has removed to 155 West 72nd St., New York City. John S. Dunham is president.

Hi 30 The World's Premier Custom-Built RADIO



Band-Filter Tuning
Screen-Grid Amplifier
Six Tuned Circuits
World-Wide Range

COMPLETE
FACTORY
WIRED
AND
TESTED
UNITS

NO radio produced in mass can even approximate the skilled perfection of the new Custom-Built "HiQ-30." Here is the newest, most efficient model by Hammarlund—the climax of five years of unequalled custom designing and famed throughout the world, for power, selectivity and tone. A great opportunity for custom-set builders. Choice of magnificent cabinets and speakers.

List, \$139.50 to \$1,175 complete, less tubes.

Mail Coupon for 48-page "HiQ-30" Manual

HAMMARLUND-ROBERTS Inc.
424-438 W. 33rd St., N. Y.
Enclose 25c (stamps or coin) for "HiQ-30" Manual. RB 3

Name.....
Address.....

Recently Issued Patents

Wireless Telegraph and Telephone System, Leo De Forest, New York, assignor to DeForest Radio Telephone and Telegraph Co., Jersey City, N. J., corporation of Delaware. Filed July 1, 1924, Serial No. 723,488. Renewed May 11, 1929. No. 1,740,577.

Constant Scanning Disc, Charles Francis Jenkins, Washington, D. C., assignor to Jenkins Laboratories, Washington, D. C. Filed Nov. 5, 1928. Serial No. 317,286. 10 Claims. No. 1,740,654.

System of Secret Radiotelephony and Telegraphy, John Hays Hammond, Jr., Gloucester, Mass. Filed Feb. 21, 1924. No. 1,740,859.

Controlling Phase Relations Between Stations, Harry Nyquist, Milburn, N. Y., assignor to American Telephone and Telegraph Co., Filed Oct. 19, 1927. Renewed Sept. 13, 1929. 5 Claims. No. 1,740,867.

Exclusive Radio Transmission and Reception, Frederick K. Vreeland, Montclair, N. J. Filed Sept. 13, 1922. Serial No. 587,909. 6 Claims. No. 1,740,964.

Piezo-Electric Interference Eliminator, Herman A. Affel, Ridgewood, N. J., assignor to American Telephone and Telegraph Company, Filed July 17, 1926. No. 1,739,491.

Radio Receiving Circuits, Ralph K. Potter, New York, N. Y., assignor to American Telephone and Telegraph Company, Filed December 4, 1926. No. 1,739,520.

Electrical Transmission Circuits, Horace Whittle, Maplewood, N. J., assignor to Bell Telephone Laboratories, Inc., New York, N. Y. Filed August 30, 1926. No. 1,739,699.

Wired Radio System, Albert H. Taylor, Washington, D. C., assignor to Wired Radio, Inc., New York, N. Y. Filed January 23, 1926. No. 1,739,773.

Tuning of High-Frequency Circuits, Wendell L. Carlson, Schenectady, N. Y., assignor to General Electric Co. Filed October 4, 1928. No. 1,740,331.

Light Valve Transmitter, Charles Francis Jenkins, Washington, D. C., assignor to Jenkins Laboratories, Washington, D. C. Filed June 25, 1927.

Split Switching Gear, Charles Francis Jenkins, Washington, D. C., assignor to Jenkins Laboratories, Washington, D. C. Filed September 6, 1928. No. 1,740,354.

Arrangement For Eliminating Atmospheric Disturbances, Abraham Esau and Friedrich Lange, Berlin, Germany, assignors to Gesellschaft für Drahtlose Telegraphie m.B.H. Halesches, Ufer, Berlin, Germany. Filed July 28, 1925, and in Germany Aug. 12, 1924. No. 1,743,124.

Picture-Transmitting System, Leonard G. Abraham, Brooklyn, N. Y., assignor to American Telephone and Telegraph Company, Filed August 18, 1926. No. 1,743,180.

Method and Apparatus for Determining the Properties of Acoustic Materials, Edward C. Wentz, New York, N. Y., assignor to Western Electric Company, Inc., New York, N. Y. Filed July 13, 1926. No. 1,743,414.

Vacuum-Tube Circuits, Sidney E. Anderson, Maplewood, N. J., assignor to Western Electric Company, Inc., New York, N. Y. Filed December 24, 1923. Renewed March 16, 1929. No. 1,743,701.

Picture Transmission, Herbert E. Ives, Montclair, N. J., assignor to Western Electric Co., Inc., New York, N. Y. Filed August 20, 1925. Renewed Jan. 13, 1928. No. 1,743,856.

Photo-Amplifying System, Richard Howland



Harry A. Beach, Stromberg

Ranger, Newark, N. J., assignor to Radio Corporation of America. Filed November 18, 1924. No. 1,738,315.

Method of and Arrangement for Stray Elimination in Radio Communication, Julius Weinberger, New York, N. Y., assignor to Radio Corporation of America. Filed August 17, 1923. No. 1,738,337.

Thermionic Amplifier, Edward Herbert Trump, London, England, assignor to Radio Corporation of America. Filed Dec. 24, 1926, and in Great Britain Jan. 9, 1926. No. 1,738,408.



C. M. Blackburn, National Union

Adjudicated Patent
(C. C. A. N. Y.) Hazeltine patent, No. 1,533,858, for method and means for neutralizing capacity coupling in audions, claims 1, 2, 5, 9, 11, 12, 14, and 16 held valid and infringed. Hazeltine Corporation v. Wildermuth, 34 F. (2d) 635.

Patent Suits
1,128,292. E. H. Colpitts, Electric wave amplifier; 1,432,022. R. A. Heising, Circuit connections of electron-discharge apparatus; 1,483,273. D. G. Blattner, Circuit for heating the filaments of audions; 1,493,595, same. Amplifying with vacuum tubes; 1,501,537. H. D. Arnold, Power-limiting amplifying device; 1,514,943. E. O. Scriben, Electric wave repeater for multiplex transmission, D. C., N. D. Ohio (W. Div.), Doc. E 997, Western Electric Co., Inc., et al. v. Silverphone Corp. Decree pro confesso (notice Sept. 20, 1929)

1,173,079. E. F. Alexanderson, Selective tuning system; 1,251,377. A. W. Hull, Method of and means for obtaining constant direct-current potentials; 1,313,094. I. Langmuir, System for amplifying variable currents, D. C., N. D. Ohio (E. Div.), Doc. 2692, Radio Corporation of America, et al., v. The Sparks-Withington Co. Discontinued without prejudice Sept. 19, 1929.

1,183,875. R. V. Hartley, Electrical circuit; 1,231,764. F. Lowenstein, Telephone relay; 1,319,252. H. D. Arnold, Method of and means for utilizing thermionic currents; 1,403,475, same. Vacuum-tube circuit; 1,432,022. R. A. Heising, Circuit method connection of electron-discharge apparatus; 1,463,332, same. Vacuum-tube amplifier, D. C., N. D., Ohio (E. Div.), Doc. 2691, Radio Corporation of America, et al., v. The Sparks-Withington Co. Discontinued without prejudice Sept. 19, 1929.

1,231,764 (b) F. Lowenstein, Telephone relay; 1,493,217. R. C. Mathes, Vacuum-tube circuit, D. C., N. D. Ohio (W. Div.), Doc. E 1000, Western Electric Co., Inc., et al., v. Silverphone Corp. Decree pro confesso (notice Sept. 20, 1929).

1,244,216. I. Langmuir, Electron-discharge apparatus, and method of preparation; 1,244,217, same. Electron-discharge apparatus and method of operating same; 1,529,597, same. Electron-emitting device and method of preparation, C. C. A., 3d Cir., Doc. 3800, General Electric Co. v. The DeForest Radio Co. Decree affirmed Oct. 3, 1929.

1,244,217. I. Langmuir, Electron-discharge apparatus and method of operating same, C. C. A. 3d Cir., Doc. 3801, The DeForest Radio Co., v. General Electric Co. Decree affirmed Oct. 3, 1929.

1,558,436. I. Langmuir, Electrical discharge apparatus and the process of preparing and using same, C. C. A., 3d Cir., Doc. 3799, General Electric Co. v. The DeForest Radio Co. Decree affirmed Oct. 3, 1929.

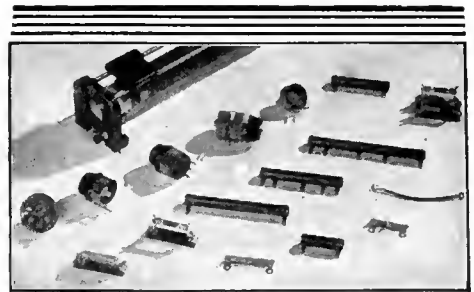

POLYMET RESISTANCES

Built to those high standards which have led 80% of the leading radio set manufacturers to adopt

POLYMET PRODUCTS

CARBON VOLUME CONTROLS
WIRE-WOUND VOLUME CONTROLS
DUAL CARBON AND WIRE VOLUME CONTROLS
SLIDING CONTACT TUBE RHEOSTATS
TAPPED VOLTAGE DIVIDERS
WIRE-WOUND TUBULAR RESISTORS
FLEXIBLE RESISTORS
FLAT STRIP RESISTORS
GRID LEAKS POLYTROLS

Ask for leaflet No. CL-1, giving diagrams of popular circuits including automobile radio receiver. A catalog of Polymet Parts is available on application.

POLYMET MFG. CORP.

Paper and Mica Condensers — Resistors
Electrical Coil Windings — Magnet Wire

837 East 134th Street
NEW YORK CITY, N. Y.

A Radio Parts Guide

THE NEW

YAXLEY

Catalog



Send for it today for complete listings of Radio Convenience Outlets, Connector Plugs, Rheostats, Fixed and Grid Resistances, Jacks, Jack Switches, Phone Plugs, etc.

YAXLEY MFG. CO.

Dept. B, 1528W Adams St., Chicago, Ill.

THE SERVICEMAN'S EQUIPMENT

(Continued from page 269)

stations which file these records will find them to be of inestimable value in following up such service calls, since a record is available of the kind of set which was serviced and how it functioned at that time, and a call in six to eight months will frequently result in a second request for service, which will probably result in the sale of a new set of tubes, at least.

One must not forget the psychology of a serviceman entering a home with proper equipment. Shooting trouble, as we did in the old days with a screwdriver and a pair of pliers, pulling this and pushing that to see what happened, simply is not accepted to-day by the consumer who knows he will later be billed several dollars for the operations of the so-called expert. However, when the serviceman shows up with a kit of instruments and proceeds to make an

analysis of the entire radio set in a logical and methodical manner, it cannot help but react on the man who pays the bills and cause him to feel he has received his money's worth, even though all that was needed was a set of tubes.

The serviceman who is making money to-day is the man with proper equipment. The service department may be an asset or a liability. It is sure to be a liability if much time is spent analyzing minor defects. But, if the serviceman can make eight to ten calls a day, analyze the trouble rapidly and accurately, and display his equipment to such advantage that the customer senses his knowledge of the facts, then sales of new tubes should result in velvet in addition to a net profit when the accounts of the service department are totalled at the end of the year.

LEARN RADIO



In a school with a reputation for graduating competent men

Dormitory—
Laboratory—
Workshop

Subjects Taught:

COMMERCIAL RADIO RADIO SERVICE
RADIO BROADCAST RADIO NAVIGATION
RADIO MATHEMATICS LABORATORY
VITAPHONE-MOVIE TONE

Write for further information

COMMERCIAL RADIO INSTITUTE

38 W. BIDDLE ST. FOUNDED 1920 BALTIMORE, MD.

IN THE RADIO MARKETPLACE

News, Useful Data, and Information on the Offerings of the Manufacturer

Stewart-Warner Console

STEWART-WARNER CORPORATION: The Stewart-Warner screen-grid eight-tube receiver is available in a Tudor period console. The set (illustrated below) is priced at \$131.50.

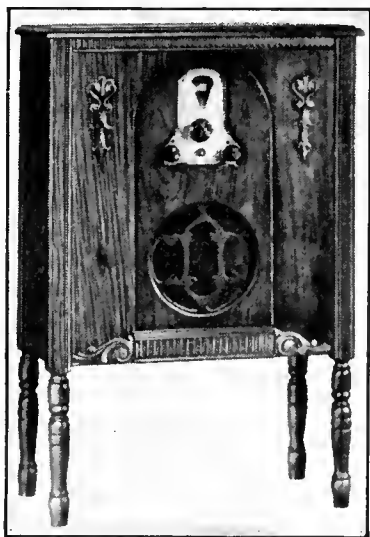

Arcturus D.C. Tubes

ARCTURUS RADIO TUBE COMPANY: This company will make d.c. tubes of the following types: 012A, 101A, 099, 122, and 071A. Arcturus previously manufactured only n.e. tubes.

New A.F. Amplifier Manual

RADIO RECEPTOR COMPANY: For the purpose of guiding servicemen and dealers in the proper planning, selection, and installation of various types of amplifier equipment this company has issued a booklet containing considerable data on amplifiers. It covers such matters as gain, loud speakers, transformers, microphones, etc. The booklet also contains complete data on the various products manufactured by this company.

Timing Device

TIMING DEVICES INCORPORATED: This unit is designed for use with a standard radio receiver, the electrical connections being such as to place the timer in series with the circuit between the radio receiver and the light socket. The unit is operated by means of a coin which causes the radio receiver to be turned on for a certain length of time.

Utah Loud Speakers

UTAH RADIO PRODUCTS COMPANY: This company manufactures a number of electrodynamic and magnetic loud speakers. The various models are priced at from \$15.00 to \$35.00. The chassis may be secured separately or the unit may be obtained in a cabinet.

Weston Tube Checker

WESTON ELECTRICAL INSTRUMENT CORPORATION: The Model 533 Tube Checker is designed for use by dealers in checking tubes as they are sold. The tube is checked by noting the reading

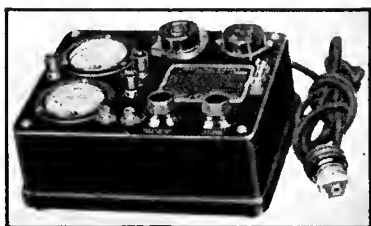

of the meter and then pressing a button and noting a second reading. From these two readings a direct indication of the worth of the tube is obtained. Price \$50.63 net.

Durham Fixed Resistors

INTERNATIONAL RESISTANCE COMPANY: Modifications in the coating material and in the size of the filament have made it possible for this company to design resistor units with three or four times the safety factor of present units. Units rated at 1 watt have been placed on loads up to 15 watts at which load the heat became so intense as to melt off the end cap but the conducting filament was not damaged.

Wright DeCoster Speakers

WRIGHT DECOSTER, INC.: A number of reproducers for use in connection with radio receivers but similar in design to those supplied in the sound-movie field are now being manufactured by this company. The loud speakers are available in various types of cabinets.

Volume-Control Resistors

RADIO RECEPTOR COMPANY: This company is manufacturing a new line of volume controls for various uses. The controls will be made in all ranges and sizes. In addition the company recently announced a line of microphones, electric pick-up units, electrodynamic loud speakers, and other apparatus used in a.f. amplifying systems.

New Westinghouse Charger

WESTINGHOUSE ELECTRIC AND MANUFACTURING COMPANY: The new battery charger manufactured by this company uses a Rectrox rectifier. This rectifier has a long life and is perfectly dry. The unit is ideal for charging radio and automobile batteries.



fier. This rectifier has a long life and is perfectly dry. The unit is ideal for charging radio and automobile batteries.

DeForest Dry-Cell Tube

DEFORREST RADIO COMPANY: The 499-type audion differs from the 199-type tube mainly in its filament construction. The 499 uses an oxide-coated filament of about three times the cross sectional area of the usual thoriated tungsten filament while emission from the 499-type filament is about four times that obtained from the thoriated tungsten type. The tube has a mutual conductance of 415.

An oxide-coated filament is also used in the 422A, the DeForest d.c. screen-grid tube. Emission from the filament averages 50 milliamperes and the filament current is only 60 mA. at 3.3. volts.

Automatic Phonograph

HOLCOMB AND HOKE MANUFACTURING COMPANY: This company manufactures a number of continuous-playing, automatic, electric phonographs. The unit uses a three-stage audio-frequency amplifier with a ten-inch electrodynamic loud speaker. The units are made with or without a coin-operated mechanism.

Atwater Kent Model 100

ATWATER KENT MANUFACTURING COMPANY: A new walnut lowboy cabinet, Model AK-100, has been added to the regular line of cabinets available exclusively for Atwater Kent

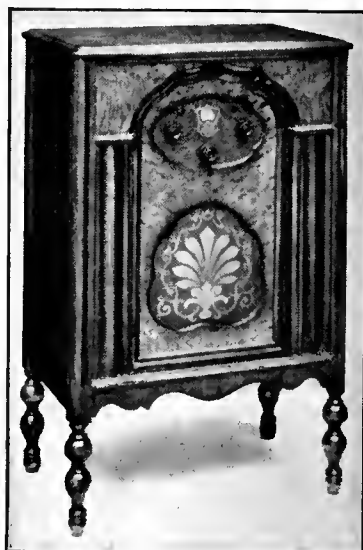

screen-grid receivers. The dimensions of the new cabinet are: height 33 1/2", width 24 1/2", and depth 15".

Fleethheim Fixed Condensers

A. M. FLEETHHEIM AND CO., INC.: This company manufactures a complete line of by-pass condensers, filter condensers, high-voltage transmitter condensers, and grid and plate blocking condensers for use on potentials up to 2000 volts d.c. By-pass condensers are available in various capacities from 0.1 to 4 mfd., and filter condensers in capacities up to 4 mfd. and in blocks.

Clarostat Volume Control

CLAROSTAT MANUFACTURING COMPANY: To meet the requirements of receivers in which the volume control must operate simultaneously in two circuits the dual-type wire-wound resistor has been designed. It is made up of two standard units mounted in tandem. Each unit may be wound to any resistance and a power switch may also be included in the assembly.

Wall Type Loud Speaker

BEST MANUFACTURING COMPANY: A loud speaker has been designed especially for installation in hotels, schools, and other buildings where programs are distributed by a centralized amplifier. It is 10 1/2" square, is equipped with a magnetic unit, and is designed to be installed in the wall of a room.

New Philco Models

PHILADELPHIA STORAGE BATTERY COMPANY: The Model 95 is a nine-tube receiver with automatic volume control using three screen-grid tubes, two 227-type tubes, two 245-type, and one 280-type. It is available in various models priced from \$67 to \$195. The model 76 is a seven-tube receiver using two screen-grid r.f. amplifiers, a screen-grid detector, a 227-type a.f. amplifier in the first stage, two 245-type tubes in the second a.f. stage, and one 280-type rectifier. Prices range from \$97.00 to \$225.00

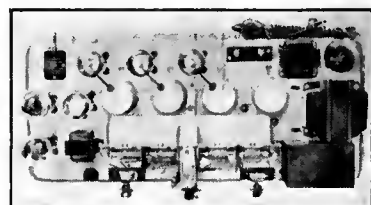

New Electrodynamic Speaker

RADIO-RECEPTOR COMPANY: The new Powerizer electrodynamic loud speaker is stated to have an effective frequency range of from 40 to 6000 cycles and to be capable of handling up to 10 watts of undistorted power. The loud speaker was originally designed for use in the Powerizer public-address and theatre-sound systems. It is now being sold as a separate unit.

Radio-Phonograph Combination

STRDMBERG-CARLSON TELEPHONE MANUFACTURING COMPANY: The Model 654 Combination uses a receiver chassis with three screen-grid tubes, a linear power detector, and a single 245-type power tube. In the upper compartment is the turntable powered by an electric motor. The pick up unit is of the low-impedance flexible-armature type. The combination is very compact measuring 46 1/2" high, 27 1/2" wide, and 17 1/2" deep.

This company also has a new lowboy console, the model 652. The model 25A electrodynamic

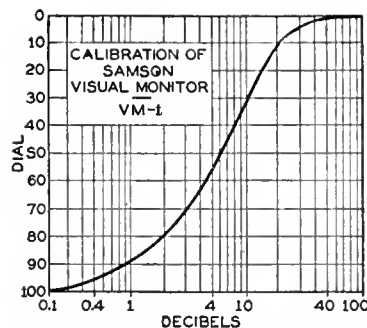

ohms. The Samson Visual Monitor, VM-1, has been developed to meet the need for an accurate indicator of volume level in power amplifier systems. It is completely a.c. operated and is arranged for standard rack mounting. It consists of a vacuum-tube voltmeter and a gain control, the action of the meter being slightly damped so that the voltmeter tends to indicate the mean levels rather than peaks. A sample calibration of the monitor is given. It will be noted that it has a total range of 100 db.

Service Instruments

THE BURTON-ROGERS COMPANY: This company manufactures a number of service instruments. The Model B Tube Checker is completely a.c. operated and will check all types of a.c. and d.c. tubes, including screen-grid tubes and rectifiers. The instrument is equipped with a standard Hoyt milliammeter with a D'Arsonval movement. Models are available for operation on 25 and 60 cycles. The 110-volt, 60-cycles model is priced at \$22.75 net. The Model C Counter Checker is also an a.c. operated instrument and with it quick tests may be made on all types of tubes and also tests may be made on dry-cell batteries, B-power units, transformers, choke coils, resistors, etc. It is equipped with a three-range instrument, 0-20mA. and 0-20-200 volts. Price: \$27.75 net. The Radio Analyzer is an instrument for testing receivers by means of adapters. The instrument is equipped with a d.c. volt-milliammeter with ranges of 0-20, 0-100, milliamperes and 0-20, 0-100, 0-200 and 0-600 volts. The a.c. voltmeter has ranges of 0-4, 0-8, 0-16, 0-160 volts. The various meter ranges are connected into the circuit by means of a rotary selector switch. Price complete with full instructions, \$58.50 net. The Direct Reading Ohmmeter, \$35.00 net, is designed to measure resistors of from 0.5 to 50,000 ohms. The instrument is operated from two flashlight cells connected inside the case.

Victor Cameras

VICTOR ANIMATOGRAPH COMPANY: This concern manufactures a complete line of home motion picture cameras and projectors. The Model 3 camera has the following features: half-speed adjustment giving 8 pictures per second, normal speed, 16 pictures per second, upper speed, 68 pictures per second, for slow-motion work; spring motor, one winding of which is sufficient for 28 feet of film, and interchangeable lenses. The Model 3 T in addition to these features has a multiple lens turret making it possible to instantly change from a close-up to a long-distance shot. Both models can be obtained in a variety of lenses. Various models list at from \$125.00 to \$200.00. The Model 3 B projector is designed for the projection of 16-mm film. In addition this company manufactures a number of accessories such as tripods, rheostats, etc. for use with their cameras and projectors.



loud speaker has been inspected by the Underwriters Laboratories and has received their approval. The model 641, 642, and 846 receivers have also been approved.

A.C. Tube Checker

JEFFERSON ELECTRIC COMPANY: A new and simplified tube checker for a.c. tubes has been



designed. Each tester is provided with a scale to indicate whether the tube is good, fair, or poor. The tester has six sockets, one each for the 226-, 227-, 224-, 245-, 171A-, and 280-type tubes. Price to dealers: \$13.50.

Samson Transformers

SAMSON ELECTRIC COMPANY: The Type 0-11 impedance-adjusting transformer consists of two identical primary and four identical secondary windings. Each primary will carry 150 mA. and each secondary 350 mA. By proper connection of the primary the transformer may be worked out of 2000 ohms or 500 ohms. The 0-12 transformer is designed especially for use in coupling a number of loud speakers or headphones in multiple to the output of an audio-frequency amplifying system. The transformer is designed to work out of 500 or 2000 ohms and into secondary loads of from 2 ohms to 1000

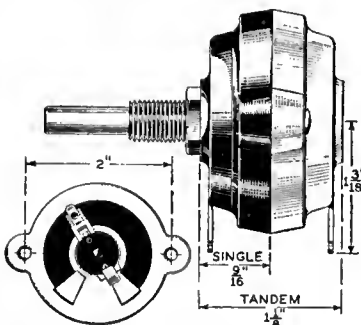
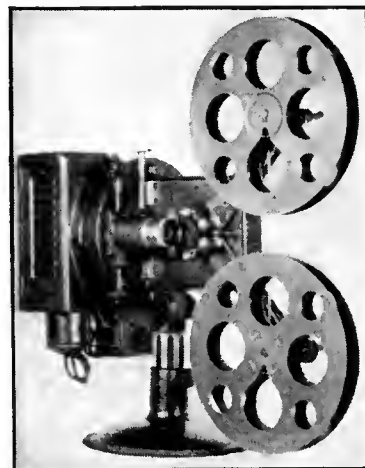

Electrad Super-Tonotrol

ELECTRAD, INC.: The Model B Super-Tonotrol combines two volume control resistors into a single unit. The advantage is that a tapered resistor can be used in the antenna circuit while a uniform resistor operated by the same shaft can be used to control the screen-grid voltage. Resistance variation in the antenna circuit is quite small during the first half of the shaft's rotation. The Model B is bakelite covered and dissipates three watts. It is available in usual sizes of resistances of practically any desired taper.

Hickok Service Instruments

HICKOK ELECTRICAL INSTRUMENT COMPANY: The Hickok Radio Set Tester, Model SG-1600, uses five meters as follows:

Plate voltmeter, double scale, 300 and 600 volts, resistance 400,000 and 800,000 ohms.

A.C. filament voltmeter, scale 3.3, 15, and 150 volts.

D.C. filament voltmeter, scale 15 volts, resistance 20,000 ohms.

Grid voltmeter, scale 100-0-80 volts, resistance 200,000 ohms.

Plate milliammeter, double scale 20 and 200 milliamperes.

By means of these five instruments it is possible with this testing device to obtain simultaneous indications of all voltages and currents, even in the case of the four-element screen-grid tube. List price \$140.00.

The Hickok Radio Tube Tester, Model B-47, is designed especially for use by manufacturers of tubes. With it all static constants can be measured and characteristic curves plotted, and by means of a.c. meters it is possible to obtain dynamic characteristics of tubes. The standard model lists at \$350.00 and the laboratory model at \$400.00

Jenkins and Adair Apparatus

JENKINS AND ADAIR, INC.: This company manufactures a complete line of transformers, retards, gain controls, mixing controls, and amplifier accessories, such as condenser microphones, microphone amplifiers, low- and high-voltage generators for plate supply attenuators, level indicators, etc. The transmitter condensers can be obtained in sizes for use in 3000-volt circuits.

Zenith New 60 Series

ZENITH RADIO CORPORATION: This series includes the model 60, 61, 62, 64, 67, and 563. All except the latter use the Zenith nine-tube screen-grid chassis. The model 60 (\$145.00 list), designated as the "Super-Midget," is a small receiver designed especially to fit between twin beds! The 61 is a lowboy console priced at \$155.00 less tubes. Other models in the 60 series range in price from \$145.00 to \$195.00.



Loud Speaker Bibliography

THE FOLLOWING short bibliography on the theoretical development of electrodynamic loud speakers was prepared by F. V. Hunt, Craft Laboratory, Harvard University.

THE DEVELOPMENT OF A HORNLESS TYPE OF LOUD SPEAKER: (This is the definitive paper that lays the foundation for subsequent design. Consulted at this date it seems incomplete, but one cannot be "in the know" without a grasp of these fundamentals.) Rice and Kellogg. *A.I.E.E. Journal*, Sept., 1925.

LOUD SPEAKERS: (A lecture delivered before the Radio Society of Great Britain in January, 1926, that greatly stimulated the discussion and development of electrodynamic loud speakers in England.) McLachlan. *E.W. & W.E.* (London), March, 1926.

A SERIES OF ARTICLES ON LOUD SPEAKERS: (General discussion of electrodynamic loud speaker design, with notes in the first on the influence of diaphragm diameter on interference effects at high frequencies. Many details of interest to the home constructor.) McLachlan. *Wireless World*, March 23, March 30, April 13, 1927.

THE OUTPUT STAGE AND THE MOVING COIL: (Report of some measurements on the impedance

of electrodynamic loud speakers and discussion of its influence on the response curve.) McLachlan. *Wireless World*, Aug. 8, Nov. 28, 1928.

RESONANCE PHENOMENA: (Consideration of the factors producing and affecting the resonant frequencies, especially the low-frequency "boom" resonance due to the diaphragm-supporting membrane.) McLachlan. *Wireless World*, Oct. 10, Oct. 17, 1928.

OUTPUT POWER MEASUREMENTS ON A MOVING-COIL LOUD SPEAKER: (Practical measurements of loud speaker output, using the method of bridge measurement of the motional resistance. In addition the equivalent electrical circuits of the electro-mechanical loud speaker system are developed in an appendix and offer a powerful approach to the design problem for one familiar with electrical filter theory.) Clark and Bligh. *E.W. & W.E.*, Sept., 1928.

LOUD SPEAKER TESTING METHODS: (Description of what is still the best method available for obtaining loud speaker response curves: condenser microphone, equalized amplifier and vacuum-tube voltmeter, and semi-automatic recording.) Wolff and Ringel. *I.R.E. Proc.*, May, 1927.

MEASURING EQUIPMENT

(Continued from page 264)

The actual frequency being generated is 1000 kilocycles, but the scale says 1002 kilocycles, so in this part of the scale the reading is 2 kilocycles too high. Points are checked every 100 kilocycles over the range of the oscillator. A table appears here which shows the scale readings and the corresponding frequencies. In no case is the variation greater than two per cent.

Modulation Characteristic

The modulation characteristic is a curve which shows the relation between the voltage on the screen grid of the modulator and the current flowing in the output circuit of the signal generator. The shape of the curve rather than the absolute values associated with it are of interest, so the current scale instead of representing actual current values represents a factor proportional to the current. When obtaining the calibration data the factor is more easily obtained than is the actual current value. The characteristic should be a straight line over the operating range of the modulator. This generator was built to modulate from zero to 50 per cent. and over this range the characteristic is very nearly a straight line.

Calibration

There are several ways by which the modulation meter may be calibrated but only one will be explained here. From the modulation curve (Fig. 2) the value of a.c. voltage that must be supplied to the screen grid of the modulator for a given percentage of modulation can be obtained. For instance, in this case the normal operating point of the modulator screen-grid potential is 140 volts and the corresponding output current factor is 200. Suppose it is desired to set the modulation at 50 per cent. The current factor must increase to 300 and decrease to 100. The curve shows that in order to effect this variation the screen-grid voltage must rise to 168 and fall to 112 volts, or considering 140 as the zero axis of an alternating voltage the peak value of the voltage must be 140-112 or 28. All that then remains to be done is to supply the screen grid with an alternating voltage of any convenient frequency and adjust its peak value until it is 28. After the modulation has been fixed the modulation meter coupling is set so that the d.c. milliammeter reads the correct value (in this case it is 6 mA.). The reading of the thermocouple microammeter is then noted. Thus a point on the calibration curve has been determined. To find other points the modulation is set at say 40, 30, 20 and 10 per cent. and the corresponding readings of the microammeter are recorded. From these data the calibration curve (See Fig. 2) is plotted.

Other Considerations

These are the calibrations ordinarily made but to be considered a dependable unit in the measurement equipment the generator must possess other characteristics. The oscillator frequency must not drift with time nor must it be subject to variations due to changes occurring in the output circuit of the generator. The generator was run steadily for four hours and it was found at the end of this period that the frequency had drifted less than 200 cycles. The extremes of conditions that can exist in the output circuit are first with maximum current flowing (the output terminals short circuited and the circuit tuned to the oscillator frequency) and second with the output circuit open (no current flowing). Under these extremes of conditions the frequency of

Loud Speaker Bibliography

(Continued)

Continuation of foregoing paper, showing several actual curves and discussing their interpretation. Wolff. *I.R.E. Proc.*, Dec. 1928.

A HIGH-EFFICIENCY RECEIVER OF LARGE POWER CAPACITY FOR HORN-TYPE LOUD SPEAKERS: (This is a detailed description of the Western Electric 555-w unit now being used chiefly for "talkie" installations. One hesitates to use the superlative but it is probably the best loud speaker now made, yielding honest efficiencies of 25-50 per cent. from 50 to 5000 cycles and with no resonance peaks. Unfortunately the horns required to do the unit justice makes it unsuitable for home use. Wentz and Thuras. *Bell System Tech. Journ.*, Jan., 1928.

NEW MOVING-COIL LOUD SPEAKER. *Journ. Scient. Instr.*, June, 1929, V. 6, pp. 197-198.

THE ACOUSTIC PERFORMANCE OF A VIBRATING RIGID DISC DRIVEN BY A COIL SITUATED IN A RADIAL MAGNETIC FIELD. N. W. McLachlan. *Phil. Mag.*, June, 1929, V. 7, No. 46, pp. 1011-1038.

DESIGN DATA ON THE MOVING COIL: (Some notes on the most efficient coil and its correct design.) L.E.T. Branch. *Wireless World*, May, 1929, V. 24, pp. 561-564.

THE MOVING COIL LOUD SPEAKER: H. M. Clarke. *E.W. & W.E.*, July, 1929, V. 6, pp. 380-384.

MOVING-COIL LOUD SPEAKERS, WITH PARTICULAR REFERENCE TO THE FREE-EDGE CONE TYPE. C. R. Cozens. *E.W. & W.E.*, July, 1929, V. 6, pp. 353-368.

SOUND RADIATION FROM A SYSTEM OF VIBRATING CIRCULAR DIAPHRAGMS. I. Wolff & L. Malter. *Phys. Review*, June, 1929, V. 33, pp. 1061-1065.

THE "BREAKING UP" OF LOUD SPEAKER DIAPHRAGMS. N. W. McLachlan. *Wireless World*, July 10 & 17, 1929, V. 25, pp. 33-35 & 62-64.

MESSUNG DER GESAMPTENERGIE VON SCHALLQUELLEN: (Measurement of Total Energy of Sound Producers.) E. Meyer & P. Just. *Zeitsch. f. tech. Phys.*, Aug., 1929, V. QP, No. 8, pp. 309-316.

Loud Speaker Bibliography

(Continued)

UBER NEUERER AKUSTISCHE: (New work on acoustics and in particular electro-acoustics.) F. Trendelenburg. *Zeitschr. f. Hochfreq. Tec.*, Oct., 1928, Vol. 32, pp. 131-135.

PRESSURE DISTRIBUTION IN A FLUID DUE TO THE AXIAL VIBRATION OF A RIGID DISC. N. W. McLachlan. *Proc. Roy. Soc.*, Feb. 4, 1929, V. 122A, pp. 601-609.

THE EFFECT OF A FINITE Baffle ON THE EMISSION OF SOUND BY A DOUBLE SOURCE. M. J. O. Strutt. *Phil. Mag.*, March, 1929, No. 43, V. 7, pp. 135-158.

APPARENT EQUALITY OF LOUD SPEAKER OUTPUT AT VARIOUS FREQUENCIES. L. C. Hector & H. N. Kozanowski. *I.R.E. Proc.*, March, 1929, V. 17, pp. 521-535.

TRANSIENTS ALIAS "ATTACK": (Natural oscillations of loud speaker diaphragms.) N. W. McLachlan. *Wireless World*, April 3 & 10, 1929, V. 24, pp. 346-348, 385-388.

DOES A VIBRATING DIAPHRAGM CARRY A MASS OF AIR WITH IT? G.W.O.H. (Editorial) *E.W. & W.E.*, March, 1929, V. 6, pp. 117-118.

ON THE SOUND WAVES RADIATED FROM LOUD SPEAKER DIAPHRAGMS. *E.W. & W.E.*, April, 1929, V. 6, pp. 175-177.

A.E.G. COIL-DRIVEN LOUD SPEAKER: (Rice-Kellogg) F. A. Fischer and H. Lichte. *A.E.G. Mitt.*, Jan. 1929, No. 1, pp. 25-31.

THE INDUCTOR DYNAMIC: (Farad Loud Speaker Movement.) H. P. Westinab. *QST*, Aug., 1929, Vol. 13, pp. 29-30.

TRANSIENTS IN LOUD SPEAKERS AND AMPLIFIERS: (How sudden changes in sound intensity affect the amplifier; the important effect of a choke-filter output.) N. W. McLachlan. *Wireless World*, Aug. 7 & 14, 1929, Vol. 25, pp. 118-121, 154-157.

ACOUSTIC PRESSURE AND VELOCITY RELATIONS ON A CIRCULAR DISC AND IN A CIRCULAR ORIFICE. A. G. Warren. *Phys. Soc. Proc.* 40, pp. 296-298. *Disc.* 299 Aug. 1928.

THE ELECTRODYNAMIC LOUD SPEAKER: (Good brief discussion of motional impedance with some notes on practical design.) E. A. Uehling. *RADIO BROADCAST*, Dec. 1929, pp. 113-115.

the oscillator varied less than 20 cycles. This freedom of the oscillator frequency from output circuit conditions results from the use of the screen-grid tube as the modulator. That is, the screen-grid tube prevents the succeeding tube circuits from reacting upon the oscillator circuit.

Neither the degree of modulation nor the shape of the modulating wave must be affected by circuit conditions. Both the output tubes and the amplifier preceding them operate as linear devices under all circuit conditions and so the degree of modulation cannot be affected. The screen grid of the modulator is practically a voltage-operated device so the modulating oscillator is at all times operating under substantially open-circuit conditions. Consequently the modulating wave shape is good under all operating conditions.

The output current must not fluctuate. The motor-generator supplies power at constant voltage independently of normal line-voltage fluctuations so the output current is not subject to undesired variations.

The output current must be reasonably free from harmonics. In this generator the amplitudes of the harmonics that may be present are so small that their effect upon measurements being made is negligible.

Conclusions

Criticisms have at various times been directed against the use of these larger tubes in this equipment. The argument being that the same results could be obtained with the smaller tubes (201, 171, 224) and reductions could be made in the size of the equipment and the expenses of maintaining it. But experience has demonstrated that with the larger tubes the generator characteristics remain constant for long periods of time and the maintenance expense in general is not excessive. When batteries constituted the power supply there were important considerations in favor of the smaller tubes, but the motor-generator eliminates these considerations and actually reduces the original cost and subsequent maintenance expense.

In the next article in this series there will be described measurement apparatus which is used in conjunction with the signal generator.

PRODUCTION TESTING EQUIPMENT

(Continued from page 275)

tial except that the galvanometer deflection is lessened as the battery voltage decreases.

Carbon Resistors

In testing carbon resistors where the resistance varies inversely with the current flow it is necessary to test them under very nearly their normal load condition. We find that by applying the necessary potential and measuring the current flow a satisfactory test can be made on these carbon items.

As can be seen by referring to Fig. 5 the test fixture consists of a voltmeter and milliammeter connected so that the voltmeter measures the drop across the resistor and the milliammeter the current through it. The C battery and potentiometer adjust the applied potential while the milliammeter shunts make it possible to test a number of different resistor values on the same test fixture. Limits are indicated on the scale of the milliammeter and, of course, are of the same width for all carbon resistors where the acceptance limits are similar.

a smooth start and a steady pull

The giant electric locomotive starts with velvet smoothness and pulls the heaviest loads over steep mountain grades with steady, unflinching power.

It's all a matter of proper control.

The increased sensitivity of your radio demands the s-m-o-o-t-h control that only Centralab can give. Noiseless, free of inherent sputtering—self inflicted static. For smooth, quiet, velvety radio reception your radio must be CENTRALAB equipped.

Write Dept. 218 E, for free booklet "Volume Controls, Voltage Controls and Their Uses."

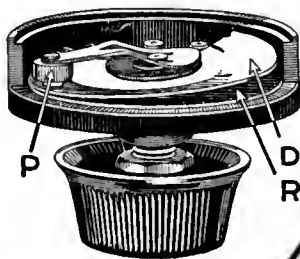

THIS shows the exclusive rocking disc construction of Centralab volume control. "R" is the resistance. Contact disc "D" has only a rocking action on the resistance. Pressure arm "P" together with shaft and bushing is fully insulated.



Centralab

CENTRAL RADIO LABORATORIES

Dept. 218-E, Keefe Ave., Milwaukee, Wis.

TYPE 360 TEST OSCILLATOR



One of the new test oscillators for the radio service laboratory is now ready. It will deliver a modulated radio-frequency voltage at any point in the broadcast band (500 to 1500 kilocycles) and at 175 and 180 kilocycles. The tuning control is calibrated with an accuracy of 2 per cent.

The Type 360 Test Oscillator is intended to be used for neutralizing, ganging, and tuning of the radio-frequency stages in a receiver, and it is fitted with an output voltmeter for indicating the best adjustment. This voltmeter is of the copper-oxide rectifier type, and by means of a switch it may be connected across a 4000-ohm load or across the dynamic speaker of the receiver when making tests.

Price \$110.00

GENERAL RADIO COMPANY

30 State Street

Cambridge, Massachusetts

Modulated Oscillators and Output Meter

ONE of the most important tasks in the servicing of radio receivers is the accurate alignment of the tuning condensers and the accurate adjustment of the neutralizing condensers. Although these operations may be carried out by tuning the set to some local station and making the necessary adjustments while listening to the a.f. output, this method is not very accurate. It is much better to set up a local oscillator and an output meter so that the input to the set and the a.f. output are reasonably constant and so that slight changes in the adjustments can be detected readily.

On "Laboratory Sheet" No. 332 are given the circuits of two simple modulated oscillators and two output meters that may be used in checking a receiver. Oscillator No. 1 is designed for operation on a.c. and oscillator No. 2 for operation from batteries. The a.c.-operated oscillator uses a 226-type tube supplied from a filament transformer and plate potential is obtained by connecting the plate lead to the primary of the power transformer. The oscillator will then have 110 volts a.c. on its plate and will be modulated by the a.c. The battery-operated oscillator uses a 199-type tube and the grid leak and condenser values are such that

they will function to modulate the output. It is, essential, of course, that the oscillator be modulated so that a note will be audible in the output of the loud speaker connected to the set under test.

The output meter No. 1 uses a 226-type tube as a rectifier in series with an 0-10 milliammeter and a 1-to-1 output transformer. The output meter of oscillator No. 2 simply uses a 1-to-1 transformer to whose secondary an a.c. milliammeter is connected. If an a.c. milliammeter is available this is, of course, the simplest circuit but if a d.c. milliammeter must be used it is necessary to rectify the output by some circuit such as is indicated by circuit 1.

In use the output meter terminals marked "to set" are connected either directly across the moving coil of the electrodynamic loud speaker or, if necessary to get sufficient reading, across the primary of the transformer supplying the loud speaker. The oscillator is set up near the set and located at such a point that a satisfactory deflection is obtained on the output meter when the set is tuned to the frequency being generated by the oscillator. The various condensers can then be accurately aligned until maximum deflection is obtained on the meter.

Modulated Oscillator and Output Meter

THE CIRCUITS on this sheet show arrangements that can be used to supply a constant modulated signal to a receiver for testing purposes and also output meter circuits that can be used to in-

dicate qualitatively the output of the set. All specifications are given on the circuits and some notes on their use will be found in "Laboratory Sheet" No. 331.

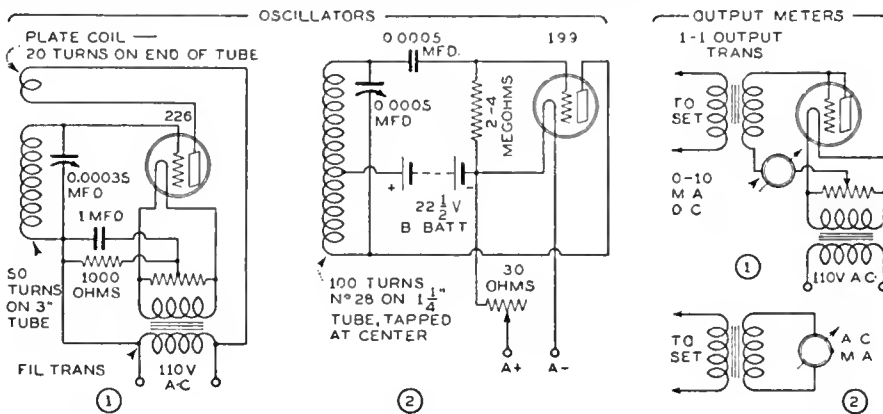

Calculating Power Output

ONE of the simplest and most effective ways of calculating the power output of an ordinary three-element power tube is by the use of "load lines" plotted across a group of characteristics showing the relation between the plate current and plate voltage for various grid biases. A group of plate current-plate voltage curves for the 171A-type tube are given on "Laboratory Sheet" No. 334 and the following notes indicate how the load lines are determined.

It should be noted that these curves show the plate current obtained for various plate voltages at grid biases corresponding to from 0 to -30 volts. The first thing to do is to pick out the normal operating point of the tube, which in this case is -40, volts and 20 milliamperes. The tube has a plate resistance of 2000 ohms and for maximum undistorted output the load resistance would therefore be 4000 ohms. We now have to lay off the line to indicate the manner in which the plate current will change with grid voltage. This is not difficult. With no signal on the grid the plate current will be 20 milliamperes. Now assume that the plate current changes from 20 milliamperes to 40 milliamperes. This means that there will be a change of 20 milli-

amperes in the current flowing through the 4000-ohm resistor. By Ohm's Law the resistance, 4000 ohms, multiplied by this current, 20 milliamperes, gives the change in voltage across the 4000-ohm resistance, or in this case 80 volts. We, therefore, mark on the diagram point B at a plate current of 40 milliamperes and a plate voltage of 100 (80 volts less than the normal operating potential of 180 volts). A line is then drawn from the operating point at 20 milliamperes and 180 volts so as to pass through the point B. This is the load line corresponding to a load resistance of 4000 ohms.

Load lines for values other than 4000 ohms can be calculated in this same manner. For example, if the load resistance is 2000 ohms then a 20-mA. increase in plate current will produce a 40-volt change across the load resistance. This gives us point C at a current of 140 milliamperes and a plate voltage of 40 volts. Drawing a line between C and the operating point A gives the load characteristic corresponding to 2000 ohms.

In future Sheets we will show how these load lines may be used to determine the power output of the tube and also the percentage of second-harmonic distortion.

STRAYS FROM THE LABORATORY

(Continued from page 273)

Electric company and used in their laboratories (and probably for sale), but takes considerable space to describe how it is used, the importance of the shape of condenser plates, how to get good wave form at low frequencies, etc. It should be digested by every engineer engaged in radio- and audio-frequency laboratory work.

Despite the fact that *QST* is edited primarily for the audience whose interest and activities lie in the frequencies higher than 1500 kc., we are continually surprised and pleased with the amount of material of interest to broadcast-frequency engineers. In the November (1929) issue will be found an article on the use of an interesting mechanical rule for determining the proper load resistance for power amplifiers, and to simplify power output and distortion calculations. This article is by K. S. Weaver, Westinghouse Lamp Co., Bloomfield, N. J. Another article by Technical Editor James J. Lamb describes the uv-815, a low-impedance linear power amplifier and modulator tube of the 50-watt type. A third article on "Operating Characteristics of Vacuum Tube Oscillators," by H. A. Robinson, belongs with the engineer's file of vacuum tube circuit articles.

THE ADAPTORON

(Continued from page 253)

have some effect on the wave form, but, as indicated in Fig. 8, load resistance of from about 6000 ohms up to about 40,000 ohms does not have a serious effect. The effect of changing the length of the commutator segments for a constant load and a specific filter system had a somewhat greater effect. Fig. 9 gives the data for this case. Second and third harmonics are

(Continued on page 303)

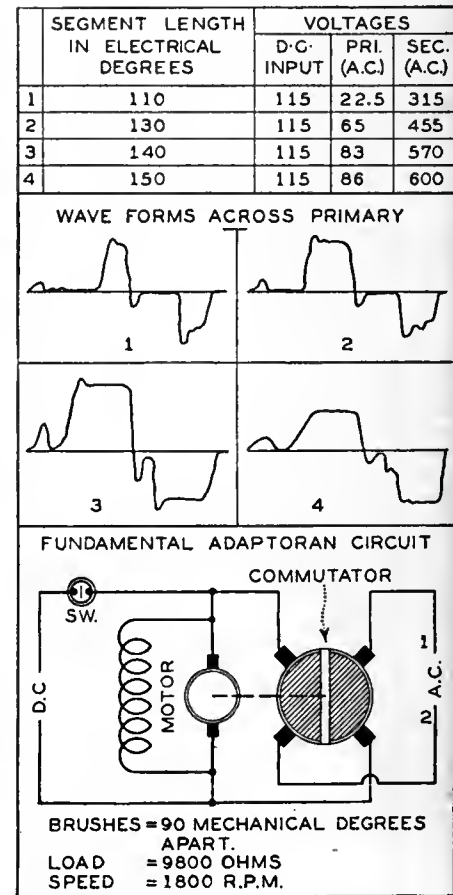

Fig. 4—Effect of varying length of commutator segments.

(Continued from page 302)

largely responsible for the shape of these curves. The third curve for a segment length of 160 degrees seems to indicate a third harmonic with a value of about 25 per cent. of the fundamental.

Practical Uses

The wave shapes indicated in the various figures shows that from this device one can obtain a number of different forms, some quite peaked and others quite flat relative to the effective value.

The application of this device is, of course, not limited to that of permitting the operation of a.c. radio receivers from d.c. lines. It has application wherever low-power devices that function best on a.c. must be operated in d.c. districts. In many of these applications somewhat better results are obtained with wave forms other than sinusoidal, and by the proper choice of the segment length and the filter system these special wave forms can be obtained.

Special Adapteron circuits are necessary when the unit is called upon to supply

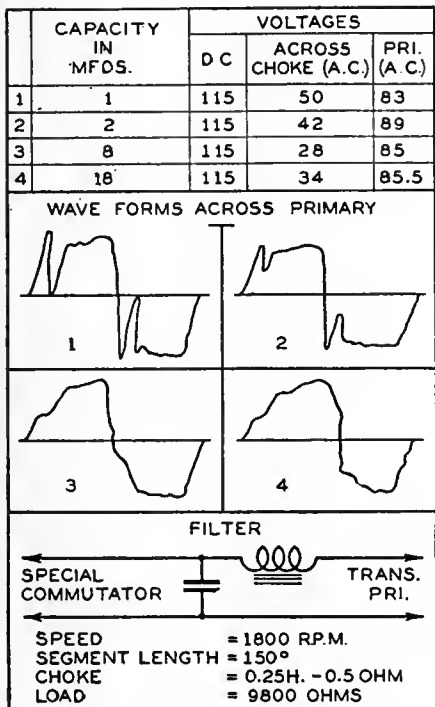

Fig. 5—Effect of parallel capacity and series inductance.

loads of low power factor. As a matter of interest two special circuits are shown. Neon tube circuits are designed with a transformer which has very high secondary leakage reactance in order to maintain a constant secondary current; consequently the power factor is usually poor—40 per cent. being unusually good and from 17 to 30 per cent. being average.

In designing an Adapteron for these circuits, a condenser feed was decided upon and the circuit utilized is shown in Fig. 1. Resistors, R_1 and R_2 , are placed across the condensers to limit the voltage across them. As, if a condition of resonance is reached, the current in the circuit is very high and some care must be taken in the circuit design to prevent such a condition from occurring in practice.

The bell-ringing circuit is shown in Fig. 2. As bell-ringing circuits are similar, it is possible to design a more simple filter to take care adequately of the conditions met with in this type of service.

In the use of this device in the consoles of standard a.c. receivers several points, such as the location and grounding of the elements of the filter circuit, the shielding, etc., are very important.

The complete circuit of an Adapteron of the type used with radio receivers is shown in Fig. 3. Technically, the circuit

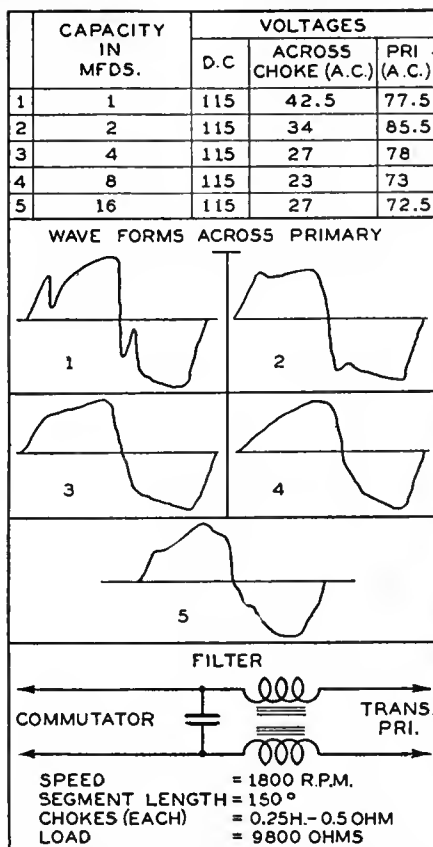

Fig. 6—Effect of parallel capacity and choke in both sides of line.

is quite interesting. The problem of preventing the radio-frequency oscillations generated by commutation from reaching either the d.c. lighting mains or the a.c. output leads was solved by the filter circuits shown.

During the tests it was found that although no appreciable r.f. energy was reaching either power line, the signal reaching the set from the antenna was distinctly annoying, particularly at certain frequencies. Later tests proved that the unwanted energy was being picked up from the single shield then employed around the entire equipment. The ground lead, too, was decidedly "hot." This condition was remedied by the introduction of a double shield, the two shields being insulated from each other. All radio-frequency leads (Continued on page 304)

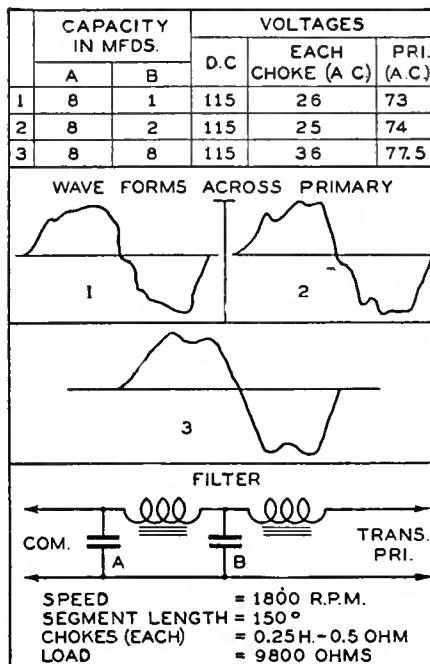

Fig. 7—Effect of different capacity combinations.



PILOTRONS

These tubes, built to satisfy professional radio engineers and custom set-builders, will surely satisfy your customers. "Good Sets Deserve Pilotrons, Others Need Them!" Pilot Radio and Tube Corporation, 323 Berry Street, Brooklyn, N. Y.

RADIO Isn't Modern Without Automatic VOLTAGE CONTROL

See that the electric radio you buy or build is equipped for the AMPERITE Self-Adjusting LINE VOLTAGE CONTROL. Prevents noisy voltage fluctuations. Improves Reception—Saves Tubes.

Write for Useful Bulletin. Address Dept. RB 3

AMPERITE Corporation
561 BROADWAY, NEW YORK

AMPERITE Self-Adjusting LINE VOLTAGE CONTROL

ROBERT S. KRUSE

Consultant and Technical Writer

103 Meadowbrook Road, West Hartford, Conn.
Telephone Hartford 45327

Wanted:

Representative in each town for new easy selling proposition to home-makers. Generous commissions, bonus and sales help supplied. Especially attractive offer to club or civic workers. Apply

Box R. B. % The American Home Garden City, N. Y.

Calculating Power Output

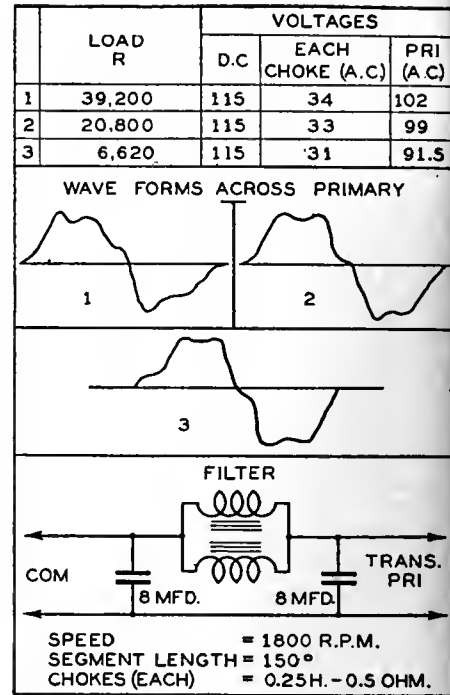
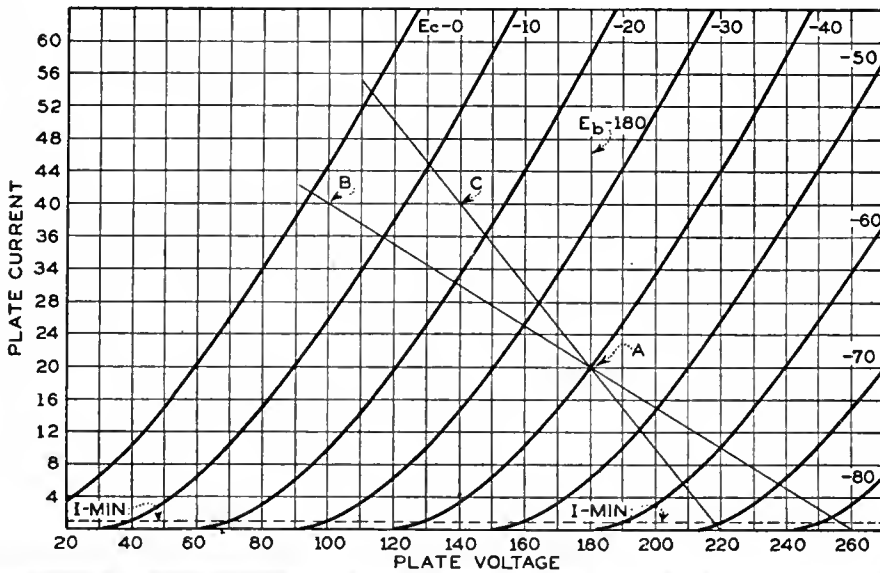

Fig. 8—Effect of varying load resistance.

(Continued from page 303)

were returned to one common point and this point was grounded to the outer case at one point. The point on the outer case also formed the ground connection.

Experimental models of the Adaptoron have been in actual use for some time operating standard a.c. sets in d.c. districts. They have functioned entirely satisfactorily. The line noise audible from the loud speaker has generally been much less with an a.c. set powered from the Adaptoron than from an ordinary standard d.c. receiver.

One of these units has been in continuous operation, except for short examination periods, in New York City since November 19, 1929. All components are in perfect condition and operation is more satisfactory now than originally.

The circuits shown are developments of the Ward Leonard Electric Co., Mount Vernon, New York, and are being produced under their patents and patent applications.

Undistorted Output vs Dynamic Range

THE DYNAMIC range in volume which a radio receiver can handle depends largely on the maximum undistorted power output from the power tubes, upon the minimum acoustic power output, and upon the efficiency of the loud speaker. In this sheet and the following some figures are given which serve to give some idea of the maximum undistorted power output required with loud speakers of various efficiencies for dynamic ranges of 20 to 60 db, all the figures being based on the assumption that the acoustic sound output from the loud speaker at minimum volume is 5 microwatts. Some relative idea of this power may be appreciated from the fact that the average power in speech is about 10 microwatts.

An example will clearly indicate the basis on which these figures were determined. Assume that the sound output power at minimum volume is to be 5 microwatts, that the loud speaker has an efficiency of 3 per cent., and that the ratio between maximum and minimum volume is 40 db, corresponding to 10,000 to 1 in power. If the minimum sound output is 5 microwatts then the power input to the loud speaker for minimum volume is equal to the sound output divided by the efficiency which gives 0.167 milliwatts input to the loud speaker.

If the ratio of maximum to minimum power is 10,000, then the maximum power input to the loud speaker must be 10,000 times 0.167 or 1670 milliwatts which is equal to 1.67 watts. The figures used in this example correspond to those given in the second line of the data on "Laboratory Sheet" No. 336.

As will be noted the table on the following sheet is worked out for loud speaker efficiencies of from 2 to 10 per cent, and for dynamic ranges of from 20 to 60 db. Each 10 db increase in dynamic range, of course, requires a ten-fold increase in the maximum power output from the receiver. The maximum power output required for any given dynamic range is an inverse function of the efficiency of the loud speaker so that doubling the efficiency halves the power output required. The maximum output requirements also depend naturally upon what sound output at minimum volume is decided upon. In the table 5 microwatts is assumed but, of course, if this level is cut in half the power output for maximum volume is also halved. The power outputs indicated under the columns 20, 30, 40, and 50 db are expressed in milliwatts. The power outputs under 60 db are expressed in watts.

Undistorted Output vs Dynamic Range

THE TABLE below serves to indicate what dynamic range in volume can be handled with a certain loud speaker efficiency and some definite value of acoustic power output at minimum volume.

The basis for the figures and a brief explanation of their meaning will be found on "Laboratory" Sheet No. 335. Note: The figures under columns 20, 30, 40, and 50 represent power output in milliwatts.

Efficiency of Loud Speaker	Power Output for Minimum Volume	Maximum power output in milliwatts required for a DB difference between minimum and maximum volume of				
		20	30	40	50	60
2 %	0.250	25	250	2500	25000	250 watts
3 %	0.167	16.7	167	1670	16700	167 "
4 %	0.125	12.5	125	1250	12500	125 "
5 %	0.100	10.0	100	1000	10000	100 "
8 %	0.062	6.2	62	620	6200	62 "
10 %	0.050	5.0	50	500	5000	50 "

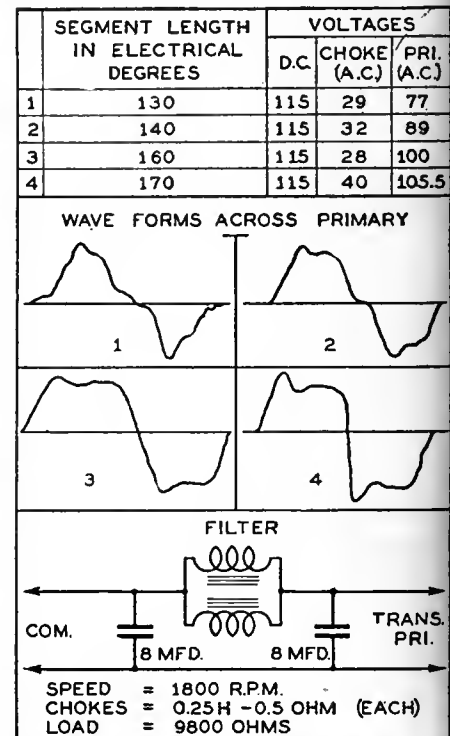

Fig. 9—Effect of changing segment length.



Open this FREE BOOK

and you open
the door to

SUCCESS in

RADIO

YOU, too, can be trained for a big-time radio job... Clip this coupon now and send for this **FREE BOOK**... Read it page by page... see for yourself why thousands of fellows just like you are now making from \$50 to \$100 a week... why many others earn as high as \$10,000 to \$15,000 a year and even more. This free book gives you 40 fascinating pages of pictures and text, all about RCA Institutes, the only school that is endorsed by the Radio Corporation of America... The school that actually sends you radio instruction direct from RCA... the very source of radio achievement!

Easy to Learn Radio At Home in Your Spare Time

Let the RCA Institutes Home Laboratory Training Course give you the real inside facts of radio... quickly and easily. Use your spare time to train for success with the remarkable

outlay of screen-grid apparatus given to every student of this course. You learn how to solve every radio problem such as installing, repairing and servicing fine sets. This is the training that will help *you to make money in radio!*

RCA Graduates in Big Demand

For more than 20 years, there has been a well-paid position in Radio waiting for practically every graduate of RCA Institutes. This is a record unequalled by any other school. Only the vast resources of RCA could give you this practical training...

Send for this Free RCA Book "Radio... the Field of Unlimited Opportunity"

Start today on the road to Success in Radio... Send for this **FREE BOOK**. Every page is packed with pictures and text telling you all you want to know about RCA Institutes, the oldest and foremost Radio training organization in the world. Radio can easily be **YOUR ROAD TO SUCCESS**... That's why you should

Clip this Coupon NOW!

RCA INSTITUTES, INC.

Formerly
Radio Institute of
America



RCA INSTITUTES, Inc.
Dept. RB-4, 75 Varick Street, New York

Gentlemen: Please send me your **FREE** 40-page book which illustrates the brilliant opportunities in Radio and describes your laboratory-method of instruction at home!

Name.....

Address.....

RADIO BROADCAST

*Suspended
with April, 1930*

WILLIS KINGSLEY WING Editor
HOWARD E. RHODES Technical Editor
EDGAR H. FELIX Contributing Editor



VOL. XVI. NO. 6

ENGINEERING • THE LABORATORY • SERVICING

Contents for April, 1930

Review - - - - -	W. K. W.	309
Industrial Changes	Problems	
The News Parade	Voice in the Wilderness	
Automobile Radio	The Pentode Again	
Licenses	New Models and a Trend	
Radio on Trains		
An Automatic Record Changer - - - -	Thomas E. Piazza	310
Book Review - - - - -	Edgar H. Felix	312
<i>Radio Law</i> by W. Jefferson Davis		
Measurements of High-Frequency Response -	Jesse Marsten	313
Tube Manufacturing Equipment in the Ken-Rad Factory, etc.		315
The March of Radio - - - - -	An Editorial Interpretation	316
Misleading Radio Advertising	The Coming of the Pentode	
Broadcasting Achievement	High Power vs City Areas	
Characteristics of Television Signals - - -	C. H. W. Nason	318
Automobile Receiver Design - - - - -	Robert S. Kruse	320
High-Frequency Measuring Equipment - - -	H. D. Oakley	324
Measurements on Band-Pass Filter Circuits -	W. T. Coeking	326
The Investor Looks at Radio - - - - -	Berkeley A. Cater	329
Aircraft Radio Development - - - - -	Elmer L. Brown	330
Strays from the Laboratory - - - - -	Technical Shorts	333
Sun Spots and Radio	A Correction	
British Heater Tubes	Pentode Articles	
Measuring Percentage Modulation	Baron Manfred von Ardenne	334
Automatic Volume Control - - - - -	A. C. Matthews, Jr.	336
"Radio Broadcast's" Engineering Review Sheets - - - - -		337
Factors Governing Amplification	Calculating Amplification of Pentode Receivers	
Professionally Speaking - - - - -		339
1930 and Service	New Tubes	
The Serviceman's Corner - - - - -		340
Technique of Servicing	An SOS to Servicemen	
A Hum Filter	Two Simple Oscillators	
Servicing the Radiola	A Legal Question	
Data on Crosley Sets	More "Dope" on Noise	
"Radio Broadcast's" Set Data Sheets - - - - -		344, 346, 348
Bremer Tolly Models S-81, S-82	Grebe Super-Synchrophase SK-4	
The Balkeil Model C	The Kennedy Chassis No. 10	
News of the Radio Industry - - - - -		350
Tube Makers Defend the Pentode	News of the Manufacturers	
Personal Notes	Matters Legal	
Recently Issued Patents	In the Tube Field	
	Remote-Control Patents	
In the Radio Marketplace - - - - -	Offerings of Manufacturers	354
Radio Broadcast Laboratory Information Sheets		
	Howard E. Rhodes	356, 358, 360
No. 337. Measuring Resistance	No. 341. Reflection of Sound	
No. 338. Types of Distortion	No. 342. Grid Current in Tubes	
No. 339. Detection Characteristics	No. 343. Speech Power and its Measurement	
No. 340. Calculating Detector Output	No. 344. Speech Power and its Measurement	

The contents of this magazine are indexed in *The Readers' Guide to Periodical Literature*, which is on file at all public libraries

... among other things

Elmer Brown, who writes in this issue about aircraft radio developments since 1929, has been with the RCA as an engineer, first at Van Cortlandt Park, New York, and now at Camden where he specializes in competitive receivers, special receivers and equipment. He has been with Magnavox, the U. S. Navy, and several West Coast distributors. *Jesse Marsten* admits that just thirteen years ago, he took his first commercial job in radio at the old Marconi plant at Aldene, N. J. "Thanks to the U. S. Navy and the Signal Corps," says Marsten, "enough work was provided to give us the experience that Mr. Wegeant, then the chief engineer, promised Carl Dreher and me as compensation for accepting \$10 a week. With the formation of the RCA out of the remains of the Marconi Company, I joined Dr. Goldsmith's research staff at C.C.N.Y. This staff was the nucleus of the RCA Technical and Test Department." For the past three years Mr. Marsten has been chief engineer of Freed-Eisemann. During the last eight years *C. H. W. Nason* has been with Federal Telephone and Chas. Freshman Companies in engineering work and has also done some consulting. He is at present developing television transmitter systems and audio-frequency amplifiers for Jenkins. His chief claim to fame is his operation of amateur station 3YK and that he was one of the last of the amateur fraternity to lay down the reactionary banner of "The Spark Forever." *Thomas E. Piazza* was born in Arequipa, Peru, and came to this country in 1926. He is intensely interested in development of mechanical devices and for the past eighteen months has been in the mechanical department of the Technidyne Corp.

The *Balkeil Radio Company*, of North Chicago, was never in bankruptcy we have been informed by R. L. Eglaston, now vice president of the company. It was incorrectly stated on page 251 of our March issue that Balkeil was involved in a bankruptcy action. This report reached us from a source which we believed to be correct and was printed in good faith. We greatly regret this occurrence and offer our sincere apologies to the Balkeil Company and its dealers. Set Data Sheet No. 36 in our January issue showing a Fada receiver indicated a 171A tube in the first a.f. stage whereas a 227 type is the tube actually employed.

For coming issues we can forecast, in addition to all our regular features, the following: an article by W. R. G. Baker, chief engineer of Radio-Victor, on engineering personnel problems; R. S. Kruse describes "R39," a new insulating material; H. D. Oakley, an attenuator for the signal generator; R. C. Hitchcock on design data for output transformers; Jesse Marsten on measurements of antenna-coupling systems in broadcast receivers; Baron von Ardenne on a system for measuring vacuum tube characteristics using the cathode-ray tube.

TERMS: \$4.00 a year; single copies 35 cents; All rights reserved. Copyright, 1930, in the United States, Newfoundland, Great Britain, Canada, and other countries by

DOUBLEDAY, DORAN & COMPANY, INC., Garden City, New York

MAGAZINES

COUNTRY LIFE . . WORLD'S WORK . . THE AMERICAN HOME . . RADIO BROADCAST . . SHORT STORIES . . LE PETIT JOURNAL . . EL ECO . . WEST BOOK SHOPS (Books of all Publishers)

NEW YORK: <LORD & TAYLOR, JAMES MCCREERY & COMPANY, PENNSYLVANIA TERMINAL, 10 WALL STREET, GRAND CENTRAL TERMINAL, 51 EAST 44TH ST., 848 MADISON AVE., 105 EAST 57TH ST., 370 and 420 and 526 and 819 LEXINGTON AVENUE.> ATLANTIC CITY: <2807 BOARDWALK> CHICAGO: <75 EAST ADAMS ST.> ST. LOUIS: <310 N. 8TH ST. and 4914 MARYLAND AVE.> CLEVELAND: <HIGGEE COMPANY> SPRINGFIELD, MASS: <MEEKINS, PACKARD & WHEAT.

OFFICES

GARDEN CITY, N. Y. NEW YORK: 244 MADISON AVENUE. BOSTON: PARK SQUARE BUILDING. CHICAGO: PEOPLES GAS BUILDING. SANTA BARBARA, CAL. LONDON: WM. HEINEMANN, LTD. TORONTO: DOUBLEDAY, DORAN & GUNDEY, LTD.

OFFICERS

F. N. DOUBLEDAY, Chairman of the Board; NELSON DOUBLEDAY, President; GEORGE H. DORAN, Vice-President; RUSSELL DOUBLEDAY, Secretary; JOHN J. HESSIAN, Treasurer; LILLIAN A. COMSTOCK, Ass't Secretary; L. J. McNAUGHTON, Ass'l Treasurer

REVIEW

◆ **INDUSTRIAL CHANGES**—*Colonial* merges with *Valley Appliance*, of Rochester, combining, it is said, "the best features of each" from sales down through engineering. *Fulton Cutting* is chairman of the Board, *I. G. Maloff*, chief engineer, and *W. S. Symington*, president. *Magnavox* reorganized as a Delaware corporation to facilitate, it is darkly hinted, a merger. *Erla*, of Chicago, is said to be out of receivership; *Marti*, of East Orange, is reorganized and will sell sets direct to power companies in and near New York. *Temple*, of Chicago, was bought by a syndicate headed by *Leonard Welling*, formerly a New York Majestic distributor. *Bremer-Tully*, of Chicago, is discontinued as a sales organization and present *Bremer-Tully* sets are being unloaded.

◆ **THE NEWS PARADE**—President Hoover reappointed the entire Radio Commission, seemingly ignoring the strong opposition to some members which has developed, based on their record as radio administrators. All have been confirmed by the Senate. *Gen. Saltzman* was chosen chairman. Passage of a Communications Commission Act appears inevitable and this Commission would have radio as only one of its complex problems.

In the last year, said President *Richard* of RMA, 25 per cent. of the radio manufacturers maintained price levels, 35 per cent. cut prices, and 40 per cent. were in financial difficulties. This statement, made before the Cleveland Convention of the N. F. R. A., was not received kindly by the attending luminaries who felt that such public frankness was not politic.

◆ **AUTOMOBILE RADIO**—*Michael Ert*, retiring president of N.F.R.A., told members of his association that the installation of radio receivers in automobiles offered great profit possibilities to the radio industry in the coming years. . . . *New Hampshire State Commissioner of Motor Vehicles Griffin* says: "New Hampshire is against automobiles equipped with radio which can be operated while the car is in motion. This department is satisfied that the greater percentage of accidents is due to inattention of drivers, and where a radio is being operated while the car is in motion it certainly would tend to divert the attention of the operator". . . . Sales and service of the *Delco* automobile radio, made by *General Motors*, will be handled

SOME OF the events in the world of radio in recent weeks may have escaped you. A few of the more important, to our way of thinking, are presented on this page.

by *United Motors Service* which has 3000 authorized service stations and 27 "control branches" in the United States . . . *Willard Battery* service stations will install and service *Transitone* automobile radios.

◆ **LICENSES: MORE AND LESS.**—Two tube manufacturers signed R.C.A. licenses, *Cable* and *Perryman*. Fourteen tube makers now hold an R.C.A. license. *DeForest* and *Arcturus* are not licensed. . . . On January 1, the R.C.A. licenses of *Walbert*, of Chicago, were cancelled. Shortly after, however, tuned-radio-frequency and electric-phonograph licenses were granted by R.C.A. to the *Story & Clark Radio Corporation*, of Chicago, and to the *Transformer Corporation of America*, Chicago.

◆ **RADIO ON TRAINS**—Radio installations on important trains continue. *Stromberg-Carlson's* automatic-volume-control model has been supplied to Chicago, Burlington and Quincy for three new trains added by the C. B. & Q.

◆ **PROBLEMS**—On every hand, those who struggle with radio problems refer decisively to the automobile industry as a perfect example of a well-managed industry. Says *Norman G. Shidle*, directing editor of *Automotive Industries*: "The most vital questions in the minds of factory executives now seem to relate to dealer relations in one way or another. Some of the questions getting most attention are:

1. Gearing car output to dealer and consumer demands.
2. Dealer discounts.
3. Service policies, particularly as to whether factory or dealer shall pay labor charges on parts replaced during the standard warranty period.
4. Junking plans.
5. To reimburse or not to reimburse dealers for any of losses on cars in stock at time new model is announced.
6. To reimburse or not to reimburse dealers for losses on cars in stock when a price-cut is made.
7. Possibilities of non-cancellable contracts.
8. Closed territories.

Write your own comment.

◆ **VOICE IN THE WILDERNESS**—Out of the millions of good and earnest words expended at the Cleveland convention of the National Federation of Radio Associations came a resolution to enlist the Association actively in the case of better broadcasting. Says the resolution, in part: ". . . Good broadcasting is the foundation of the radio industry and should have our support on all situations arising that affect it,

"Be It Therefore Resolved, that a standing committee be appointed . . . for the purpose of coöperating with the National Association of Broadcasters and to be ready to make recommendations to this association at any time."

Dealer discounts, tube policies, or exclusive wholesale territories don't matter much if the radio listeners don't listen.

◆ **THE PENTODE AGAIN**—News from the trademark division, U. S. Patent Office: application "Ser. No. 293,289. Radio Corp. of America, New York, N. Y., filed December 5, 1929. Trade Mark: 'Pentode' for electrical vacuum tubes and valves. Claims use since November 25, 1929." . . . R.M.A. engineering division argues that the pentode will not permit any accomplishments not possible with present tubes. For "pentode" read "screen-grid tube." How well the argument fits set designs of the season just closed! . . . The industry discussion raging around the pentode may have the effect of bringing holders of opposing points of view to the conference table. Several such meetings have already been held and further discussions between tube and set makers are in prospect. Conferences before the fact are rare in radio business where the practice has been to wait until the die is cast. . . . Says *Oscar Getz*, of *Steinitz*: ". . . I feel that it is time that the radio manufacturers should take a hand in the control of their own destinies."

◆ **NEW MODELS AND A TREND**—Since we last met, in the phrase of *Nation's Business*, *United Reproducers* has announced a new model, K-70, to sell at \$149.50, less tubes. *U. S. Radio & Television* announced the *Apex* seven-tube set complete with tubes at \$101.00, and *Sparton*, Model 589 to sell at \$159.85 complete with tubes. If two manufacturers of radio receivers offer models this early in the season priced with tubes, is it a Trend? Our answer is a slightly hesitating "Yes."

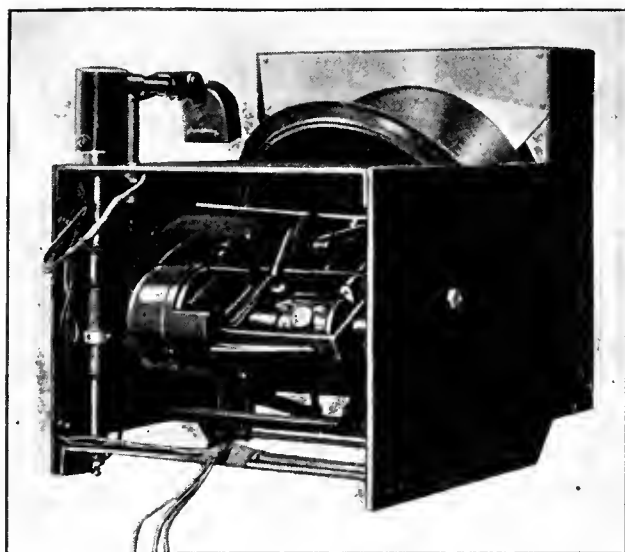

AN AUTOMATIC RECORD CHANGER

By **THOMAS E. PIAZZE**
Technidyne Corporation

THE WIDESPREAD use of radio during the last seven years for entertainment purposes in the home has created a new appreciative audience for music. At the same time experience has developed certain limitations in the use of radio which prove annoying to those in whom the desire for such musical entertainment has already been developed.

In communities a hundred miles or more from broadcasting stations, where the signals are relatively weak, there oftentimes develops considerable disturbing noise due to power line leaks, electric railways, and miscellaneous electrical industrial apparatus. It is unfortunate that these noises tend to become most pronounced in damp or wet weather due to electrical leakage over insulators or between power lines and trees or other foliage through which they pass, as it is just during such weather that most people desire to stay at home and be entertained by their radio.

The last seven years experience with radio broadcasting has also demonstrated that there are some sections in the United States where, for periods of from one to six months during the year, radio reception conditions are unfavorable due to normal static disturbances from electric storms. In such regions, and especially in sections remote from the more powerful broadcasting stations, a demand has grown up for musical entertainment to supplement the radio in the home, indicated by a growing proportion of sales of radios equipped with phonographs.

New Interest In Phonograph

Radio broadcasting from its first appearance proved a tremendous novelty. People were very enthusiastic over the variety of up-to-date music and information that radio could supply for the home. These features proved powerful enough to cause everyone to overlook almost entirely the importance of the phonograph. However, the improvement in tone quality resulting from tying up the phonograph with the radio set, together with a certain novelty value in the combination, has already created a new interest in the phonograph.

Sales of the new electrically recorded records have been increasing rapidly and it is thought that this results not only from the superior tone quality and relative convenience of the electric phonograph, but also from a strongly stimulated desire for some pieces of music frequently heard over the radio, or else brought to mind from long ago.

We believe that a more rapid growth of phonograph use will naturally follow now from the introduction of any device tending to make the operation of the phono-

graph easier and more convenient. There is no doubt but that the quality of music obtainable from good electrically recorded records reproducing through the modern magnetic pick-up unit and audio amplifying system with a quality loud speaker, as used in broadcast radio sets, is as good if not better than that which may be secured from the average radio broadcast program. Certainly when receiving conditions are bad the absence of noise tends to make phonograph reproduction a favorite.

Simplified Operation

Any device tending to reduce the attention necessary for phonograph operation tends to increase the enjoyment to be had from a phonograph program. Such things as electric-turnstile operation, eliminating the necessity of rewinding; or the use of special needle points which need only to be changed every fifty or hundred records go part way towards easing phonograph operation.

Many sales people experienced in the phonograph field believe that the greatest obstacle to the more widespread use of the phonograph is the necessity for getting up every three or four minutes to change the record. A recent attempt has been made to minimize this annoyance by building an electric turntable into a small end-table so that the record change may often be arranged near at hand. This involves the separation of the playing

instrument into two parts connected by electric cables and is not always convenient. Neither does it fully avoid frequent attention to the phonograph.

This undoubtedly suggests, why has not the automatic record changer come more into use? We asked a sales representative of one large phonograph company not marketing an automatic record changer why his company did not have one. The answer is instructive. He said, "So far, using an automatic phonograph has been like going out for a ride in a poor automobile; you might as well walk." This represents the nub of the question. No small-sized record changer so far has proved reliable for home use. We would add also that probably little sustained effort has been exerted to create an automatic record changer which is simple, fool-proof, and capable of handling the variety of records, even of one nominal size, to be found on the market. Possibly those charged with such development were especially interested in creating a machine which would handle the records manufactured by their own company and were not much concerned with what would happen if records of other manufacture were inserted.

Record Changing

Realizing some years ago that the stimulation of an active demand for automatic record-changing phonographs would be relatively easy with an instrument which

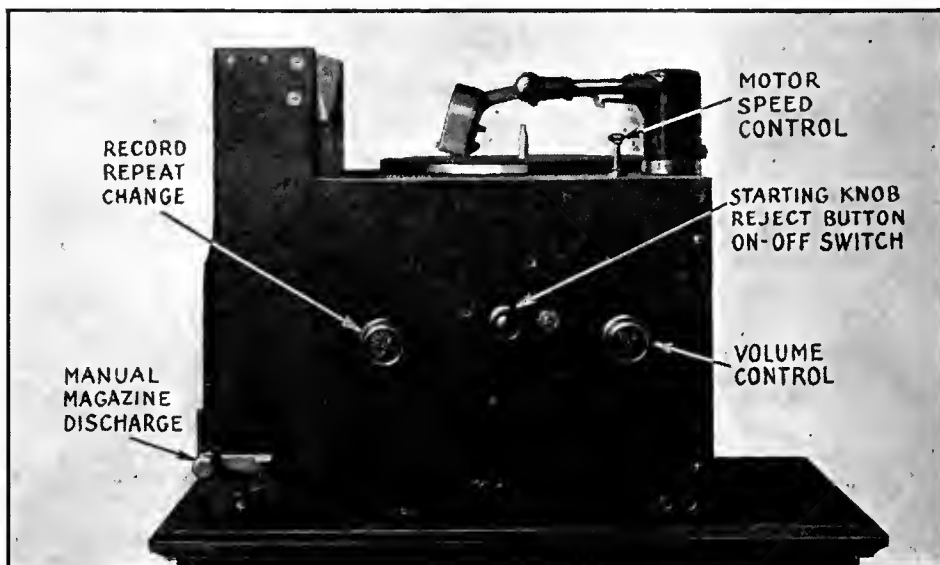

The important parts of the Technidyne automatic record changer are identified in this close-up view of the instrument.

A Description of a Simple Mechanism Handling all Types of Phonograph Records in Which the Time Between Selections Has Been Reduced to Ten Seconds. Developed in the Technidyne Laboratories.

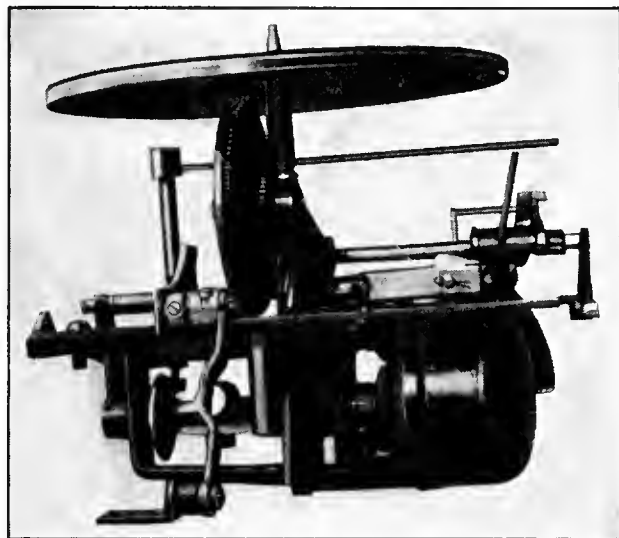

was at once universal, compact, economical, and fool-proof, the Technidyne Corporation set about the development of an ideal automatic record changer. This has been achieved and demonstrations have recently been made for leading manufacturers. A description of this machine showing the principle of its operation follows:

The record changer is shown assembled in the pictures on page 310 and the motor unit with turntable is shown at the top of this page.

The record is picked up and discharged by the turntable rotating bodily with the motor. Fig. 1 to 7 help in explaining the operation. Fig. 2 shows the records stored in a magazine ready to be played with the turntable in its normal position. Fig. 3 shows the turntable rotated through 90° and a record ejected from the storage magazine and resting against the turntable. Fig. 4 and 5 indicate the turntable rising and picking up the record.

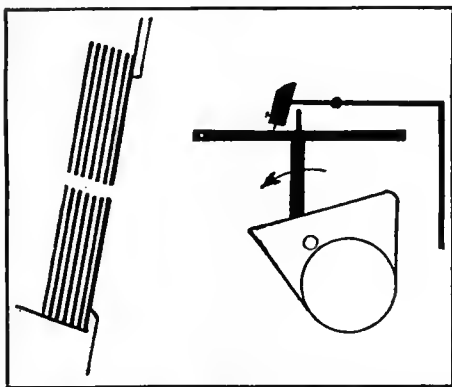

Fig. 2—Step one: records stored in magazine and turntable in its normal position.

In Fig. 4 it will be noted that the center pin on the turntable is pushing against the record and Fig. 5 shows the record falling back against the turntable with the center pin in the hole of the record.

Fig. 6 shows the record in the normal playing position with the pick-up resting on it.

Fig. 7 shows the turntable tilted through 90° with the push-rods pushing the record off the centering pin so that it can drop into the discard magazine below.

Figs. 5 and 6 indicate how the record rises underneath the pick-up thus eliminating the necessity of any mechanism for raising or lowering the pick-up unit.

How It Works

In Fig. 1 there is shown a record magazine, A, a motor and turntable, B, and a

tone arm C. The magazine A has a capacity of about twenty records and is loaded through a slot in the front of the cabinet. The machine is started from the position shown in Fig. 2 by a push-button control. The first operation of the machine is when the empty turntable tilts over through an angle of 90° at which point a

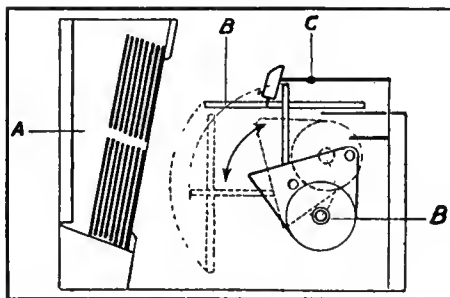

Fig. 1—Schematic drawing of the record changer. A, record storage magazine; B, motor and turntable; C, tone arm.

record is ejected from the magazine, A, and falls on fingers, D, with the upper part of the record resting on the edge of the turntable as shown in Fig. 3. The turntable rotates back to its normal playing position. During this motion the centering pin slides up the record below the center hole, bearing against the record as shown in Fig. 4.

As the turntable continues to rise to its normal position the pin engages the hole in the record as shown in Fig. 5. During the remainder of the motion towards the playing position the record is carried on the pin and finally deposited on the turntable, as in Fig. 6. After a record has

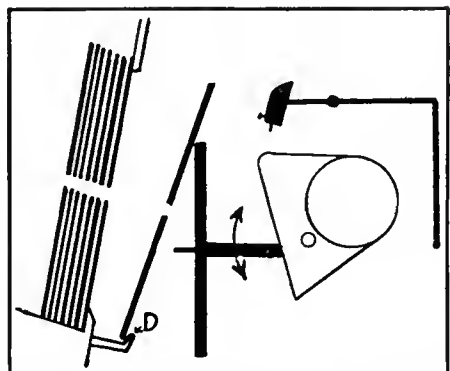

Fig. 3—Step two: turntable rotated 90 degrees and record ejected from magazine.

been played, an automatic control operates to engage a one-revolution clutch, starting the tilting operation. The turntable moves down with the record and at a certain angle the discharging fingers E disengage the record from the pin, and the record falls down to a discard magazine as shown in Fig. 7.

All Records Accepted

Any record may be played over one or more times by turning a change-repeat knob. This disconnects the mechanism of the record-storage magazine from the tilting motor so that no records are ejected for pick-up. It also disconnects the arms pushing the record off the center pin so that the record to be repeated stays on the table.

The tone arm and pick-up unit are quite free of mechanism. The pick-up is raised by the record rising underneath it as the table comes back to the horizontal posi-

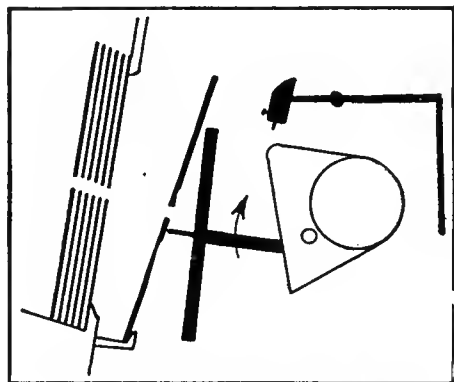

Fig. 4—Step three: turntable rising to pick up record ejected from magazine.

tion. This action is relatively gentle even though the entire cycle of change occupies only 10 seconds. This is because this part of the cycle corresponds to the crank (which tilts the table) operating in the region near dead center.

The pick-up unit is pushed inwardly by a light spring up to a stop so that the needle contacts with the outer edge of the record as the record rises, then the spring lifts the pick-up clear of the stop. This outer edge is a blank margin, but the pick-up is impelled slowly inwards towards the first sound groove by a small radial component of record motion under the needle, secured by placing the tone arm center slightly inside the tangent to the record circumference at the needle. This arrangement forms a simple way of

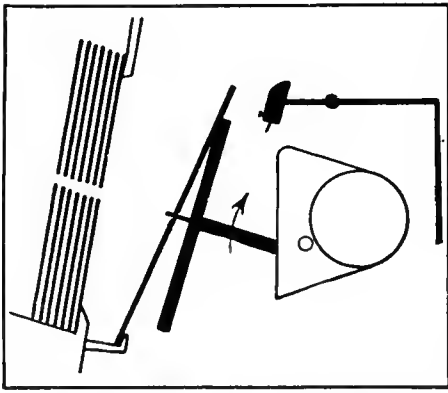

Fig. 5—Step four: turntable picks up record with center pin while returning to position.

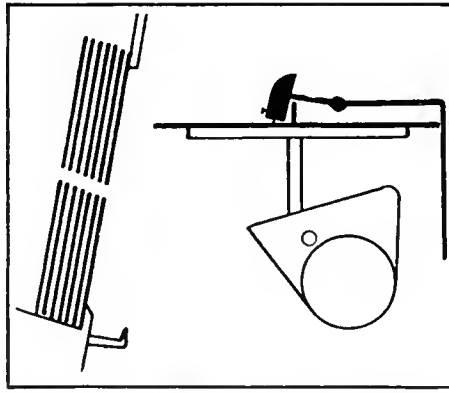

Fig. 6—Step five: turntable, phonograph record, and tone arm in normal playing position.

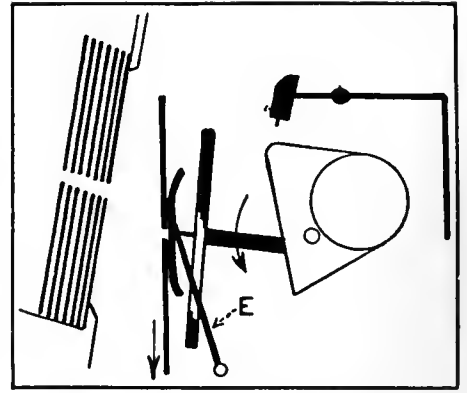

Fig. 7—Step six: turntable is tilted to reject record in the discard magazine.

insuring the playing of all records at their beginning and without loss of time.

Automatic Control

The device for initiating the record change when a record has been completed is of prime importance. It must be quick, unerring and unerring. Since various makes of records have different terminating grooves, all at different internal diameters, a quite universal device is required. The problem is complicated by the small motions, accelerations and the great diversity of normal sound groove spacings.

The Trigger Release

The Technidyne automatic control is a simple solution for this problem which is based on new mechanical principles. One of these new principles is that a smooth shaft will slip through a fairly tight bearing at a certain low axial speed very easily when the shaft is rotating but great resistance is offered for higher axial speeds.

A trigger release is held stopped on a smooth rotating shaft by a pin held balanced in unstable equilibrium on an arm rotating with the tone arm. When the tone arm either stops moving or accelerates at the end of a record this pin falls off and permits the trigger release to rotate with the shaft and start the tilting cycle. The pin falls off in a half second

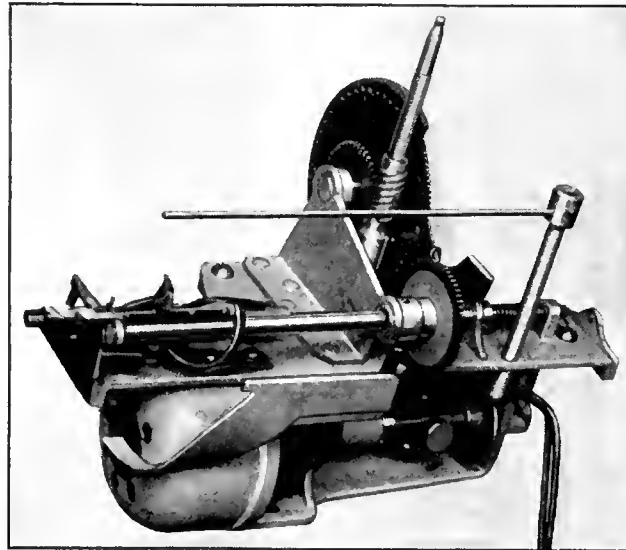

Close-up view of tilting motor.

when the needle enters a special terminating groove, and in about 6 seconds when the tone arm stops due to the needle entering the last closed groove of a record with no special terminating groove.

The development of the Technidyne automatic record changer was guided by the desire to secure a machine which, besides being simple in construction and operation, would be able to handle the great number of different makes of records now on the market. Records of one nominal

size, say ten-inch records, vary in thickness and diameter as between different manufacturers. Records will oftentimes become slightly warped due to their being stored edgewise in too hot a location, as, for example, next to a radiator. Great flexibility and reliability in handling such records has been secured in the Technidyne device by a full utilization of the principle of three-point suspension. In the record-storage magazine the record is first supported at one point below and two points above. During the operation of loading on the turn-table the record is supported at two points below and one point above, the upper point being the center pin of the turntable. Large variations in record diameter and thickness are permissible because the record remains in leaning engagement with the center pin of the turntable as the table rises. The pin must slide by the center hole of

the record at some time, and then the record must be picked up by the turntable and placed in position.

While there are undoubtedly many other good ways of mechanically performing the record changing operations we are confident that many records will be automatically changed the Technidyne way before inventive genius develops another system providing the easy and natural sequence of motions resulting from the use of the system herein described.



BOOK REVIEWS



RADIO LAW. By W. Jefferson Davis. Published by Parker, Stone & Baird Co., Los Angeles, Cal. 364 pages.

The recent work *Radio Law* by W. Jefferson Davis is not to be confused with *The Law of Radio* by Stephen C. Davis. The new volume analyzes the influence of many recent decisions which define the powers of the Federal Radio Commission and the rights of broadcasting stations.

Its author is a member of the Air Law Committee of the American Bar Association and, on the very first page, generously disposes full credit for the passage of the Radio Act of 1927 exclusively to that organization. This is indeed a fine tribute to the months of work performed by the Radio Coördinating Committee appointed by L. B. F. Raycroft and usually considered responsible for the acceptance of the compromise act finally adopted.

The book is obviously that of a lawyer

writing about radio and not a radio man writing about law. For example, he states: "Radio began as a curiosity, became the obsession of small boys, progressed to the stage of a popular amusement, and then suddenly flowered into the most overwhelming industry in the history of communications." Actually, radio has been a recognized method of communication for three decades and had a commercial communication history of twenty years before broadcasting became "a popular amusement."

However, these are small objections to a book which presents not only such a comprehensive history of radio regulation in the United States but a brief summary of its progress in Europe. The Radio Act is, of course, analyzed and supported by interpretations of the Commission's legal department on various sections. State and municipal regulations of reception and transmission; important copy-

right decisions; a comprehensive study of the work of the Washington Radio Conference of November, 1927, with the lengthy convention quoted in full; rules for hearings before the Commission; legislative defects in the prescribed procedure; the character and effect of General Order 40; and the problems of radio legislation as analyzed by the American Bar Association's Committee on Radio Law, are some of the subjects adequately covered in the volume. The index is particularly complete, making the volume a handy reference for lawyers handling radio cases.

A reading of the book makes obvious the fact that the most important decisions controlling the future operation of powers of the Federal Radio Commission are yet to be made and that amazingly slow progress has been made in defining the position and powers of the Commission during its three years of operation.

—Edgar H. Felix.

MEASUREMENTS OF HIGH-FREQUENCY RESPONSE

By **JESSE MARSTEN**
Chief Engineer, Earl Radio Corporation

Sideband Suppression as a Function of the Characteristics of the R.F. Amplifier, Detector Circuit, and Audio-Frequency Amplifier. Discussion is Based on Measurements of a Number of Modern Commercial Receivers.

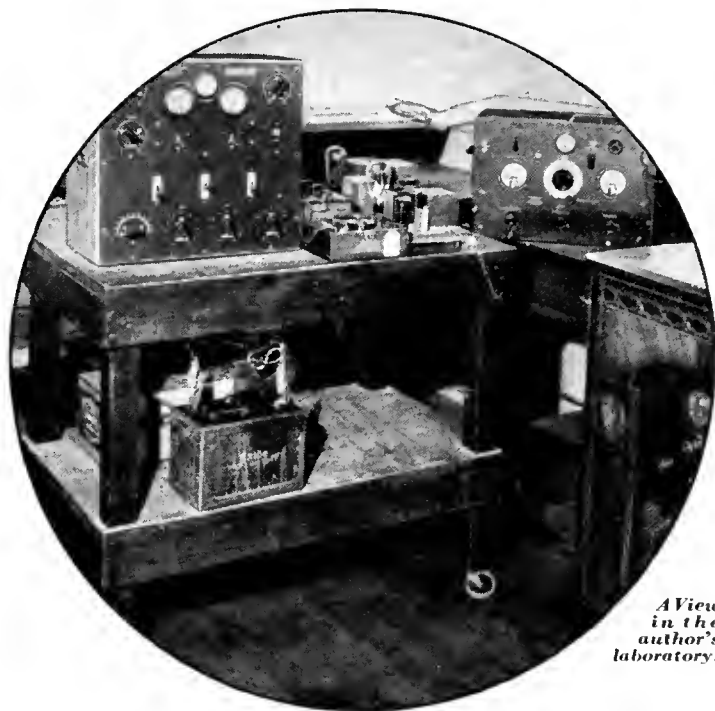

A view in the author's laboratory.

HIGH-QUALITY REPRODUCTION of sound presupposes an overall fidelity curve which is flat, or reasonably so, from 60 to at least 5000 cycles. There are two methods, generally speaking, of arriving at this objective. One is to design the component parts of the entire system so that they all have the desired flat characteristic. The other is to design the component parts so that one compensates the deficiencies of the other. The tendency among designers is generally towards the former.

While very notable gains have been made towards a realization of this goal, an examination of the fidelity curves of representative radio sets reveals that, so far as the receiver chassis is concerned, the rhapsodies of our advertising brethren are hardly justified. "True," "Lifelike," "Realistic," "Natural,"—that is what we would like the sound reproduction from our radio sets to be. We have a long way to go before such adjectives will be warranted.

Engineering Problems

There have been and still are numerous factors which have militated against securing the best grade of sound reproduction from radio sets, and our engineering compromises are simply concessions to

these factors. These are gradually being overcome with resultant improvement in quality, and the point has been reached where the most important failing is the lack of high frequencies. It may be worth while to review very cursorily the changing trends in audio-frequency reproduction over the past few years.

The early battery receivers had audio-frequency amplifiers which were woefully lacking in low frequencies, and high frequencies above 2000 or 3000 cycles. These deficiencies, unfortunately, were further accentuated by the horn-type loud speaker, then in vogue, which had similar failings. The result was "tinny" quality. The transition to the balanced-armature-driven cone loud speaker gave considerable improvement in low-frequency response, and also extended the high range somewhat. Bigger and better audio-frequency transformers appeared on the scene, and the advent of the low-impedance output tube of the 171 type improved matters still further.

By this time, just before the introduction of the a.c. tubes, high-gain, shielded, radio-frequency amplifiers were well developed, employing three and four stages of amplification. For weak signals the noise level in such high-gain receivers was

too great, and in order to reduce tube hiss and atmospheric muck, the higher audio frequencies were deliberately suppressed, either by the use of high-frequency filters or otherwise doctoring the audio-frequency system—a typical case of compromise mentioned above. This loss in high-frequency response was accentuated somewhat further by sideband suppression in the r.f. amplifier.

The A. C. Tube Enters

With the introduction of a.c. tubes a further loss in the range of audio-frequency reproduction was temporarily encountered, this time at the low-frequency end. The object, of course, was reduction of hum. However, the use of the 227-type tube and improvement in filter systems, remedied this condition, and the almost universal adoption of the electrodynamic loud speaker resulted in quite satisfactory low-frequency performance. The console type of cabinet had also arrived. By this time the dear public had learned what it wanted in the way of tone. The cry arose for "mellow tone." Frequencies above 2000 or 3000 cycles were not wanted. Loud speakers were even sold with filters in them to cut out everything over 2000 cycles, should the receiver hap-

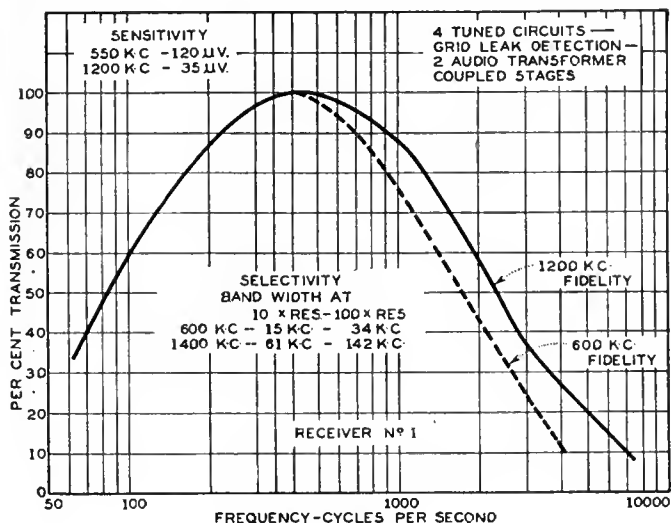

Fig. 1

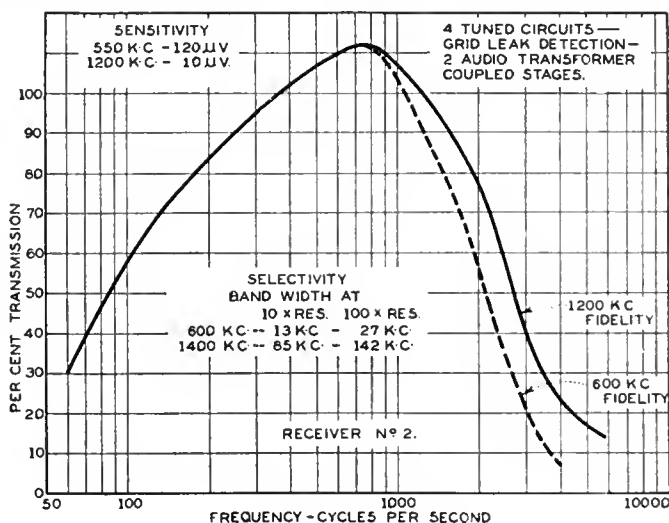

Fig. 2

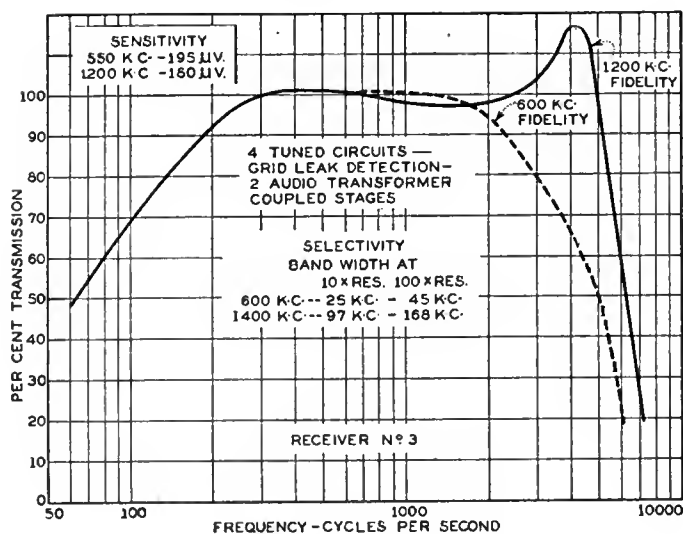

Fig. 3

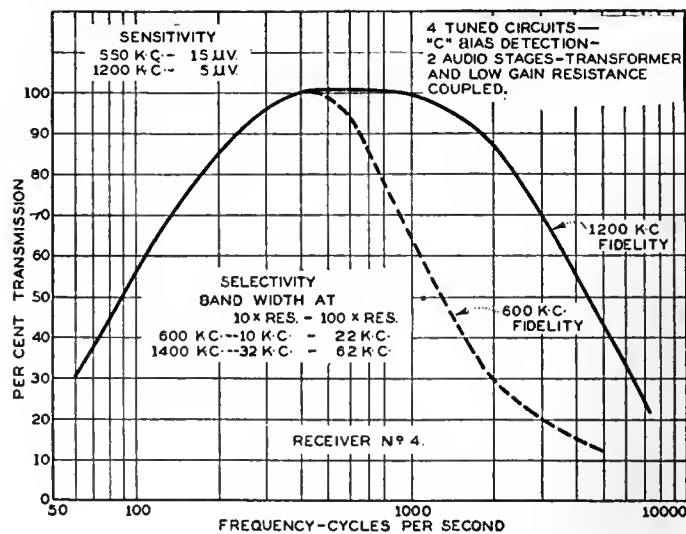

Fig. 4

pen to pass these frequencies. The public got what it wanted in an avalanche of "boom-boom." Low frequencies, loud speakers resonant at low frequencies, and cabinet resonance, all contributed to the "mellow tone" which was accentuated by lack of appreciable highs.

After a year or so of the "mellow tone" there were signs of a turn about. This meant high frequencies. Much was said about high-frequency loss in the grid-leak detector system. Band-pass filter systems were advocated to eliminate sideband suppression in the radio-frequency amplifier. Then came the a.c. screen-grid tube and with it predictions of greatly improved tone quality. The advertisements proclaimed it widely. We were to have a new era in tone quality.

Improved Design

There followed, indeed, very major improvements in receiver design, but they did not appear in the fidelity curves. High-gain radio-frequency amplifiers permitted the use of the "high-level" C-bias detector and one audio-frequency stage. The elimination of the grid leak and condenser was to improve high-frequency response. The use of a low-gain audio-frequency amplifier (one a.f. stage, or two

a.f. stages one of which was a low-gain, resistance-coupled stage) would better low-frequency response and also improve high-frequency response. However, no such improvement, in general, was ob-

good down to 60 cycles. But, except in one case, the high-frequency a.f. performance is noticeably poor.

The fidelity curves given here have been plotted using as ordinates "Percentage Transmission," 400 cycles being the reference frequency. This unit has been chosen in preference to the decibel because it shows up deficiencies much more conspicuously. A really poor fidelity curve doesn't look half bad on paper when plotted in decibel units. It may be assumed that the frequency characteristic curve of the audio-frequency amplifier in any receiver coincides with the fidelity curve of the receiver at 1200 kc. since in all receivers examined sideband suppression at this frequency plays practically no part. All fidelity curves were taken the same way with output resistance loads appropriate to the output tubes used. The method employed is that described in the suggested I. R. E. standards. Information relative to sensitivity and selectivity of each receiver is contained on each curve sheet.

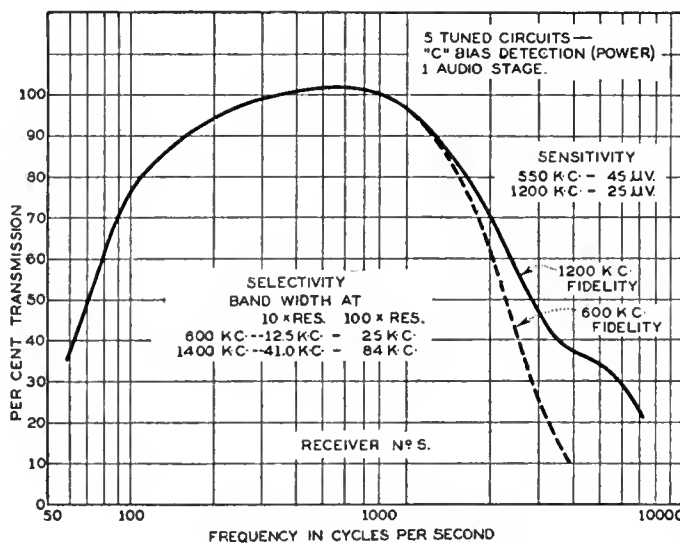

Fig. 5

served in a number of receivers examined, especially as regards the high-frequency response. The low-frequency response, in general, was satisfactory especially down to 100 cycles. In some cases it was

in microvolts input required to give 50 milliwatts output. The selectivity, in accordance with accepted practice, is expressed as the resonance band width in

(Continued on page 347)

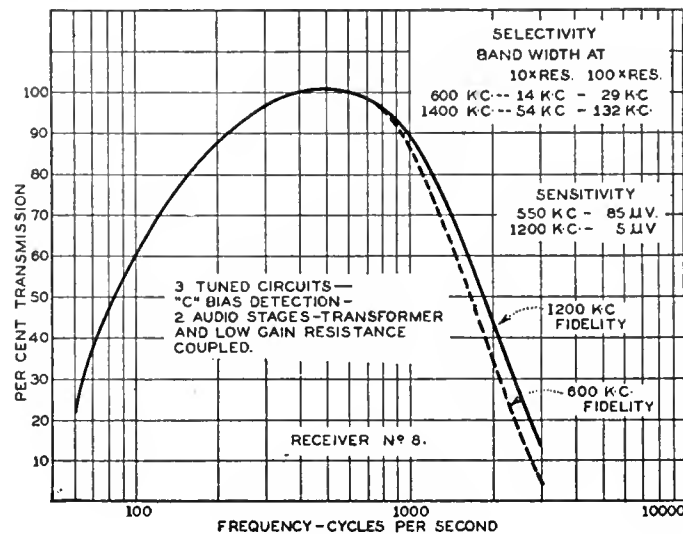

Fig. 6

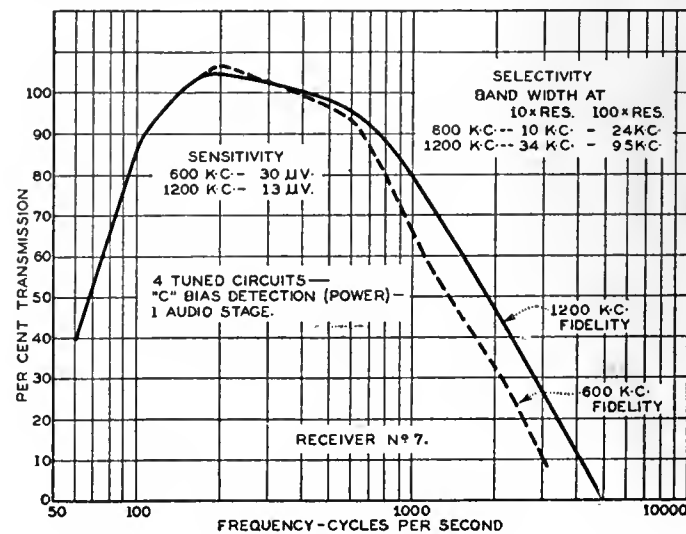
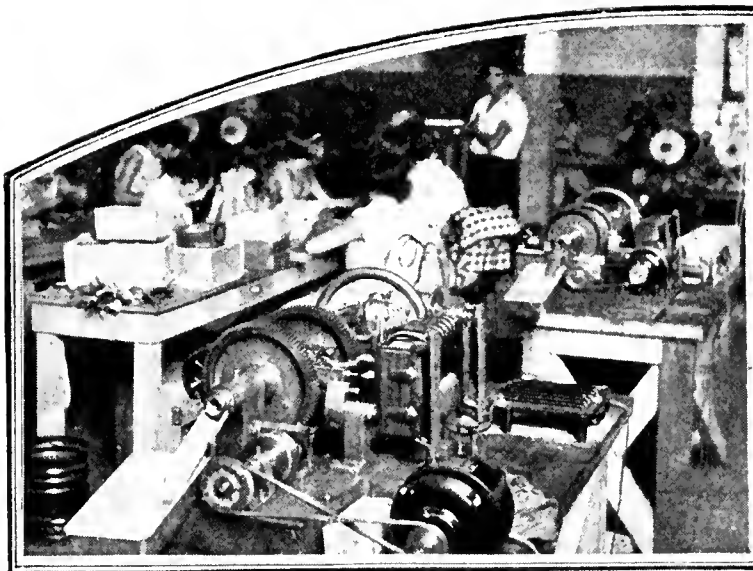
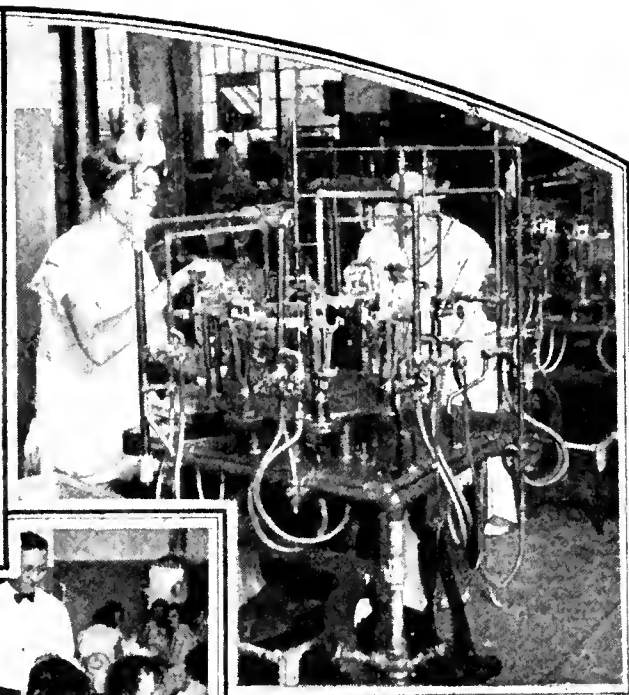

Fig. 7



Automatic grid winding machines.



*Stem forming machine.
(Left) Mounting vacuum tubes.*



General view of assembly floor where vacuum tubes are mounted.

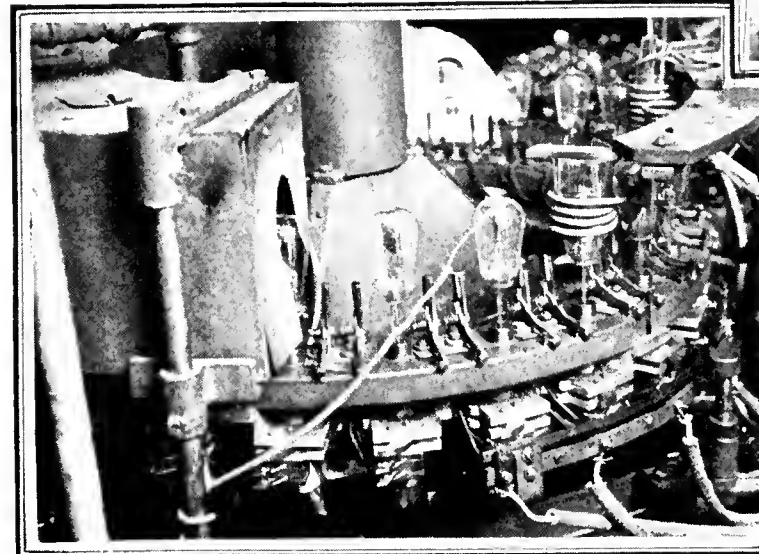

Close-up view of exhaust machine.

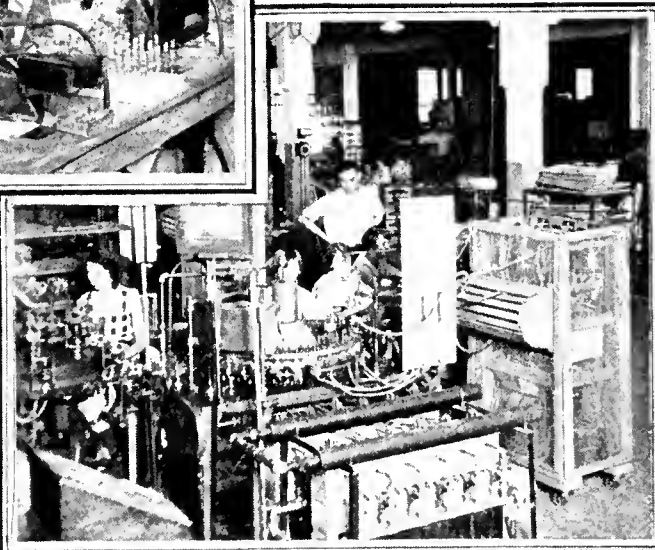

*Sealing, exhausting, basing, and soldering.
(Below) Automatic aging rack.*

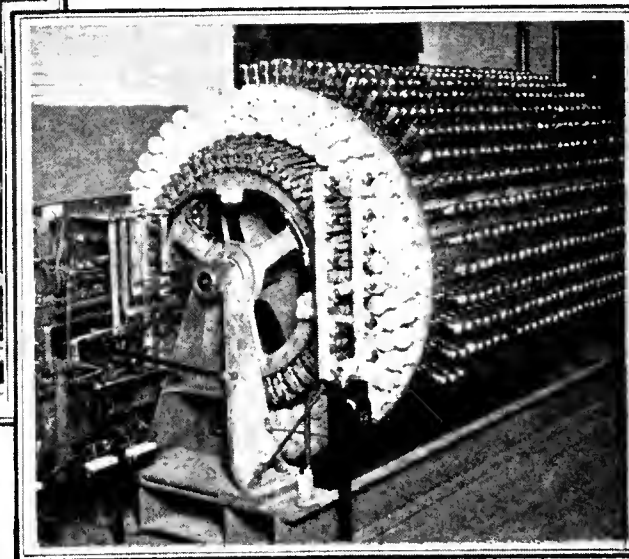

The seven pictures on this page were taken in the factory of the Ken-Rad Corporation, Owensboro, Ky., and show the wide range of equipment required for the manufacture of radio vacuum tubes in a modern plant.

TUBE MANUFACTURING EQUIPMENT IN THE KEN-RAD FACTORY

The MARCH

How Should We Advertise Radios?
Let's Reform Before We are Stamped Unreliable

Misleading Radio Advertising

The National Better Business Bureau recently compiled a list of the superlatives most frequently used by leading radio manufacturers in national advertising. The survey proved what everyone appreciates fully, that the industry is uniformly making the same hyperbolic claims for its product. The public knows that thirty or more brands cannot each be the "best" and that the claims of superiority of the cheaper sets can hardly be based on fact. Therefore, the effect of the large amounts spent for advertising is at best developing mere name familiarity.

The alternatives to a policy of advertising radio receivers by means of glittering generalities have become quite familiar. A halo is built around a coined word which means absolutely nothing, claims of technical superiority are based on a point which is in no way distinctive or unusual, and technical data is presented in a form which is usually correct but often quite misleading.

In the hope of being able to offer a specific suggestion for avoiding superlatives and basing advertising claims on a foundation of fact, we discussed the possible use of the procedure formulated by the Institute of Radio Engineers for rating radio receivers as a basis for making advertising claims with the chief engineer of a major manufacturer, who is a prominent leader in writing the standards of the radio industry. The three qualities which can be rated under the I. R. E. procedure are sensitivity, selectivity, and fidelity, the three basic factors determining a radio receiver's performance. But, it was pointed out, there is no specific way of evaluating the relative value of these qualities. An arbitrary system of rating must therefore be assumed in plotting comparisons of these qualities, which may easily produce misleading or meaningless results. It is somewhat like trying to judge the personalities of two men by charting such of their qualities as perseverance, integrity, and the knowledge each has of his business. With such a system of rating, a plodding bookkeeper might outrank a capable executive. A common denominator is required to make valid comparisons.

The fidelity of an audio-frequency system can be measured conveniently by comparing its electrical input and output. Such measurement, however, does not represent the overall fidelity of the complete receiver, as it fails to take into account the effect of the radio-frequency amplifier in cutting off sidebands and the ability of the reproducer to convert the range of audio frequencies supplied it into sound. Advantage is taken of public ignorance of these facts. The actual audio-frequency quality which the user experiences is dependent upon sound waves released by the reproducer and not upon the characteristics of the audio-frequency system alone.

Tone quality is the subject of the greatest advertising abuses. The best reproduction is attained by equalized gain over a band from 50 to 5000 cycles. Exaggeration of any part

of that range is undesirable and "colors" or modifies fidelity by a process of distortion. Wide range of response is of no significance unless accompanied by an accurate statement of the gain throughout the band. A boast of special quality of reproduction of one kind or another is usually an admission of unequalized gain or narrow response band. A receiver which is superior in selectivity and sensitivity alone is almost certain to be inferior in its fidelity as measured at the listener's ear.

Furthermore, the possession of the maximum audio-frequency range is a questionable advantage. Some of the best receivers employ an artificial cut-off below 5000 cycles because that

reduces the background noise and secures a better overall musical effect than is attained by permitting reproduction of higher frequencies. Sensitivity, likewise, can be excessive, contributing not only an unnecessary background noise but also rendering the receiver more liable to cross-talk from stations on neighboring channels and reducing the amplification of the higher frequencies.

Perhaps the most insidious type of misrepresentation is that based on scanty though correct engineering data. Under the cloak of laboratory measurements, entirely unjustified claims are easily made. A receiver is advertised with its reproduction described by actual figures for low- and high-frequency limits. Sometimes the low-frequency limit is so low that it could not be attained without a baffle considerably larger than can be made a part of the average console cabinet. A claim based on the frequency range of the audio-frequency amplification system means little or nothing; a fidelity curve of its performance but little more. The only quality curve that means anything is a comparison of the modulated radio-frequency input with the sound output of the reproducer throughout the audio-frequency range.

All of this leads us to no constructive purpose except perhaps to explain why generalities and superlatives predominate in receiver advertising. The most we can hope for at this time is a definite trend toward dignified and artistic advertising and an early end to the present era of flamboyance.

One suggestion can be adopted from the automotive industry which has somewhat the same problems as radio in finding valid advertising claims. Few of the quantity producers compare their cars with those of competitors by claiming to make the best or the finest or insisting on superiority in any particular phase of performance. Comparisons are usually made only over their own last year's models to show the features wherein improvements have been made. Why not be satisfied with a statement that the latest models of a receiver line are the finest made in the company's history and refrain from comparison with those of competitors or of the general standards of the industry? Let us reform radio advertising while the public still regards it merely with tolerant amusement and before it is definitely stamped as unreliable and misleading.

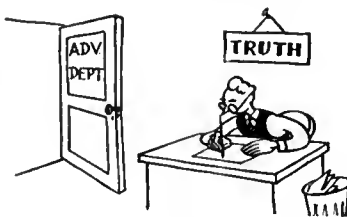
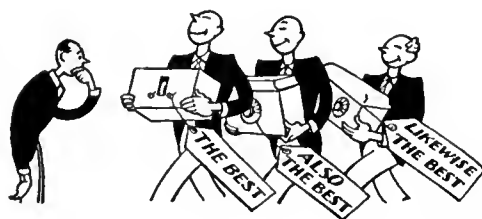

OF RADIO

The Pentode's "Greeting" by the Industry
A Suggestion—Move the 50,000 Watters Inland

The Coming of the Pentode

The radio industry treated the announcement of the availability of the heater-type pentode rather rudely. The Radio Manufacturers' Association promptly issued a statement to the effect that the new tube will bring about no improvement in performance, that its use in Europe is accounted for by the fact that royalties are collected on the basis of number of tubes in a receiver, and that the tube is unlikely to make possible reductions in the cost of receiver manufacture. As long ago as March, 1928, William Dubilier reported the existence of a German pentode receiver, giving good loud speaker reproduction, with a retail selling price of \$12.00.

The industry naturally shivers with apprehension at the very thought that its present designs may be forced into obsolescence. The alternating-current tube promptly raised mountains of selling resistance to battery receivers; similarly the screen-grid tube made the three-element type unfashionable. With the high cost of research, preparation for manufacture, and marketing of new lines, and with the still substantial stocks of unsold receivers in the hands of manufacturers, jobbers, dealers, and cut-price merchants, progress is as unwelcome as a Stock Market crash.

The screen-grid tube just as appropriately could have been greeted with the argument applied to the pentode, to the effect that the performance of a pentode receiver can be equalled with existing types of tubes.

The resistance of the industry to the pentode tube is a welcome sign. Both a.c. and screen-grid receiving sets were marketed on too wide a scale before satisfactory performance could be assured the consumer. For once the industry is not welcoming innovation with undue haste. However, the very tube and set manufacturers who issue publicity to counteract sentiment toward the pentode are at the same time working feverishly in the laboratory to perfect the tube and receivers using it. The longer this process is preferred to the usual course of merchandising half-engineered receivers to an unsuspecting public, the greater will be the ultimate contribution of the pentode in broadening the market for radios. It is quite doubtful that the first pentodes to appear have ideal or perhaps even useful characteristics. A tremendous amount of work must be done before the pentode itself is fully developed and before the art of using it is acquired by set designers.

High Power vs. City Areas

Finding that the New Jersey State Radio Commission made it too hot for the Columbia Broadcasting System's proposed 50,000-watt transmitter for WABC, the system's engineering talent directed its attention to the present location of its 5000-watt transmitter.

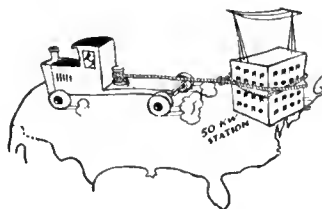
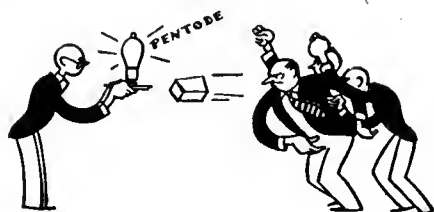

Protests were then heard from radio dealers and listeners in Brooklyn and Queens, objecting to any increase in power in that location.

The facts of the matter are that the metropolitan area of New York is much better served by 5000-watt stations located as near to the center of the area as possible, than by 50,000-watt stations sufficiently removed to avoid inconveniencing a large part of the public. No one questions the fact that work, within a few miles of Manhattan, delivers the highest value of field strength to a larger percentage of the metropolitan area than any other station, while two stations of 50,000 and 30,000 watts respectively, located at its fringe, deliver an inferior signal at the opposite rim of the circumference of the area.

It is wholly uneconomic to locate 50,000-watt stations near metropolitan centers; they should be several hundred miles from either coast. We need only consider the example of WLW, several hundred miles from the Atlantic seaboard, which gives incomparably the best rural service of any station in the country at the present time.

It has also been demonstrated clearly that, when the Commission comes out in support of a desirable engineering trend, the broadcasting fraternity manifests an active spirit of cooperation. The very trend toward the removal of high-powered stations from the center of the metropolitan areas and the efforts of various managements to acquire several stations in their areas for the purpose of consolidation is evidence of the Commission's influence. Of course, this influence has suffered a serious blow because of the fact that, after encouraging purchases of stations for purposes of consolidation, the Commission has failed to support them. Indeed, it is, in one instance at least, terming such a consolidation as an attempt at monopoly even though the original purpose of the grouping was a response to the expressed desire of the Commission to help in eliminating stations.

However, experience has proved, first, that high-power stations, close to the eastern and western seaboard, are uneconomic, while they render their greatest service when located at the center of the country and, second, that large metropolitan areas are better served by medium- and low-powered stations in their center rather than by a high-powered station some distance away.

Broadcasting Achievement

At the Senate hearings on the Couzens bill, William S. Paley testified that the Columbia system is giving 75 per cent. of its time on the air to "service programs made available at its own expense."

Prior to 1928, the system lost \$205,480; during 1928, \$172,000, and the accounting for 1929, it is anticipated, will show a
(Continued on page 349)

NOTICE
ONLY 10 SECONDS
OF ADVERTISING
ANNOUNCEMENTS

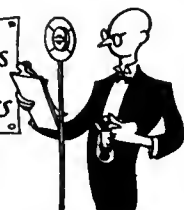

Pertinent Notes on CHARACTERISTICS OF TELEVISION SIGNALS

By C. H. W. NASON
Jenkins Television Corporation

THE DEVELOPMENT of television during the past two years has progressed rapidly. To say that we have passed the period of high-pressure development would be patently unwise; rather it might be said that television is in the same position to-day as was the broadcasting of music a decade back. Much has been written of television and it is the purpose of this article to review certain fundamental conceptions and facts regarding the television signal, its generation, transmission, and reception.

In considering the electrical aspects of the television signal we will accept as a basis the following facts: a vertical composition of 48 scanned lines; a degree of horizontal definition equivalent to 64 elements in a picture area having an aspect ratio of 3/4, as in a standard motion-picture frame; and a picture frequency of fifteen per second. The picture is to be scanned from left to right and from top to bottom as in reading the printed page. This degree of definition allows for a "head-and-shoulders" image equivalent in detail to a newspaper half-tone having an area of $\frac{3}{4}$ " by 1". The effect of motion is to increase the apparent detail by some fifty per cent.

These standards are based upon our ever-present compromise between the ideal and the possible. Increasing the number of scanned lines, the horizontal definition, or the picture frequency, results in a widening of the frequency band to be covered and a further encroachment upon the capabilities of contributing apparatus.

The lowest frequency transmitted is the picture frequency, 15 cycles. The highest frequency present in a picture of the degree of definition noted above is half the number of picture elements multiplied by the frequency of repetition or—

$$\frac{48 \times 64 \times 15}{2} = 23,210 \text{ cycles.}$$

Proper delineation of photographic film,

directly scanned images, etc. requires that, in the case of radio transmission, r.f. circuits and a.f. amplifiers pass this entire band of frequencies without discrimination or distortion. Thus it may be seen that the amplifiers of accepted usage are unsuited for this service. Short-wave receivers in their ordinary form, used without regeneration, are suitable for the reception of silhouettes or "shadowgraphs," such as are now being transmitted on regular schedule in the eastern part of the country; and such receivers will allow the reception of a passably good picture, but one lacking in sharp vertical lines, should such arise.

R.F. amplifier circuits have been developed which are capable of transmitting the entire band employed without serious attenuation of the high frequencies and represent an extreme engineering refinement of the theory of coupled circuits.

Origin of Signal

The transmitted signal has its origin in light impulses directed upon a photoelectric cell by means of a beam of light varied by the changing density of a photographic film or by the degree of light reflected from an illuminated scene.

This television signal differs widely from that of sound broadcasting, both in form and in its method of propagation. The primary signal impressed on the amplifier input from the photo-electric cell is a fluctuating unidirectional voltage of the form shown in Fig. 1. The voltage from the cell is ostensibly proportional to the illumination, the actual d.c. component about which the variations are effective being a function of the background density of the scene such as to bring the impressed voltage from the cell into the form in Fig. 2 where arbitrary values are indicated. The signal wave is therefore as shown in Fig. 3, and minus the d.c. component occurs in the form shown in Fig. 4.

The wave shown in Fig. 2 consisted of

the wave shown in Fig. 4 plus a continuous voltage of value $a + b/2$. The transients effective in the circuit reside in the alternating component shown in Fig. 4, since the impedance of the amplifier input circuit, as shown in Fig. 5, is infinite to zero-frequency components, i.e., no portion of the steady state direct current may flow.

Aperture Distortion

We have considered the necessary characteristics of a.f. and r.f. amplifiers for television service and have noted the gain-frequency performance required. There is, however, a distortion present not due to circuit deficiencies. For example, actually the form is altered by aperture distortion of the wave caused by the passing of the aperture over a change in light intensity, for a square aperture will not give a rectangular wave form as shown in Fig. 6, as is desired, but alters the wave form in the manner indicated in Fig. 7, where T' the time required for the passage of the aperture over the line in the picture corresponding to the origin of the change in light intensity.

A Fourier's analysis of the wave form in Fig. 8 gives—

$$e = \frac{E}{\pi} \int_0^{\infty} \frac{1}{\omega} \left(\frac{\sin \omega T'/2}{\omega T'/2} \right) \sin \omega t \, d\omega$$

This differs from the instantaneous values for the rectangular form by the factor within the parenthesis, the distortion from the ideal being one of amplitude versus frequency, with but slight phase distortion over the spectrum. It is necessary, therefore, to correct over the frequency band for the factor—

$$\frac{\sin \omega T'/2}{\omega T'/2}$$

The equations for the round aperture are more involved, "Sin" being replaced by the Bessels function of the first order

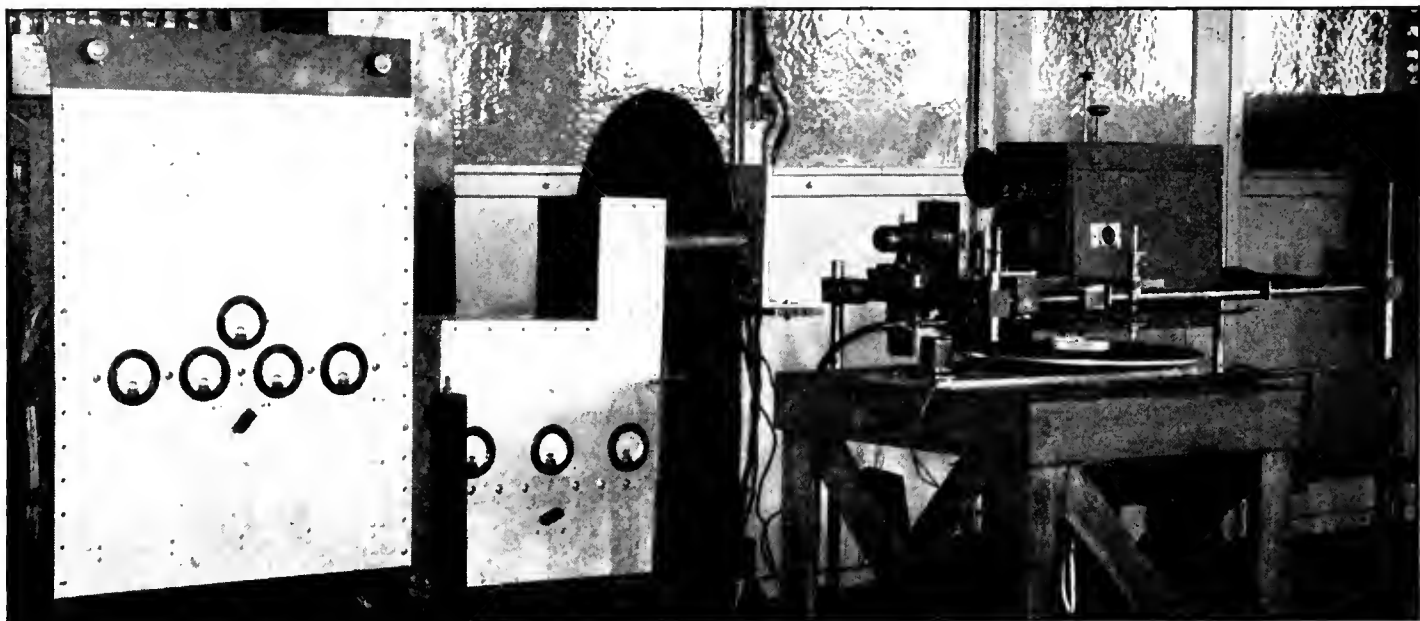

The latest Jenkins transmitting scanning system with shielded amplifiers and a synchronously driven pick-up for transmitting "radio talkies."

The Frequency Band Required for Television. Mathematical Discussions of the Various Frequency Components. Neon-Tube Circuits. Methods of Synchronizing.

which is far beyond the scope of this article. The numeric values are substantially the same as those for the square aperture and they may be taken as equal without serious error arising from the assumption.

The effect of the aperture distortion as shown in Figs. 7 and 8 may be evaluated by use of the Fourier's theorem which states, briefly, that a complex wave may be analyzed as being composed of a number of sine waves of differing wavelength, amplitude, and phase superposed one upon the other.

Size of Aperture

The aperture as applied to the scanned scene should preferably be $1/48$ of the total height, as overlap or spacing between the scanned lines is not desirable except in special cases. This clearly defines the factor T' and the frequency discrimination may be computed algebraically. This amplitude-frequency distortion may be compensated by a corrective network having little distortion of phase. Fig. 11 (page 357) illustrates the distortion occurring. Variations in the overall characteristic of plus or minus 20 per cent. are allowable without noticeable deterioration

of the image. Phase distortion ($\frac{d\phi}{d\omega}$) with frequency is not permissible in a degree of more than 10 to 20 microseconds except at the low frequencies where phase variations with frequency may be fairly large. This latter form of distortion is not usually found except where long land lines are employed for the transfer of the signal or where transformers are employed as coupling elements. Corrective networks have been developed which will compensate phase distortion without affecting the other characteristics of the circuit.

As was noted, the d.c. component of the initial signal is a function of the general

tone of the transmitted scene or the character of its background. Proper reception of the image is dependent, therefore, upon the initial illumination of the neon tubes and must be obtained by adjustment for the most pleasing appearance or by previous knowledge of the characteristics of the scene. Neon tubes employed in television reception must be essentially free from any effects of hysteresis, and their curves must be linear over a wide range. (See Fig. 12)

The Neon Tube

The neon tube may be adjusted for the proper background density by varying the plate current of the output tube. This may be done by adjusting the grid bias of the output stage, together with the plate voltage in such a manner as to continue the operation of the tube at a favorable point on its characteristic curve according to the circuit diagram in Fig. 9. A more suitable method, though more profligate in battery use, is shown in Fig. 10 where any tendency toward improper operation of the tube is avoided. Here the steady plate current of the vacuum tube is balanced out of the neon tube circuit. "R," as indicated, is made equal to the plate resistance of the tube, and the voltage of the balancing battery is adjusted for the desired current through the neon tube.

The neon tubes now on the market present varied load according to their mechanical construction and the gas with which they are filled. Those available have

an a.c. impedance of anywhere between 1000 and 8000 ohms. The d.c. resistance of the tube involves a voltage drop which must be taken into account where economy of voltages is a factor, but in general the high-impedance type is preferable when considered as the load circuit of a vacuum tube, as a load impedance considerably higher than that of the plate circuit of the output tubes usually employed in the output stage means that there will be but little curvature to the dynamic characteristic of the circuit.

The same characteristics which make the d.c. drop high, keep the inter-element capacitance of the tube down and render the impedance mostly resistive even at the highest frequencies encountered.

Synchronization

The synchronization of the scanning mechanisms at the transmitting and receiving ends presents an involved problem not only in the field of communications engineering, but in electrical and mechanical engineering as well. The simplest method is adaptable only where the a.c. power networks at the transmitter and receiver are interconnected. In this case it

(Continued on page 357)

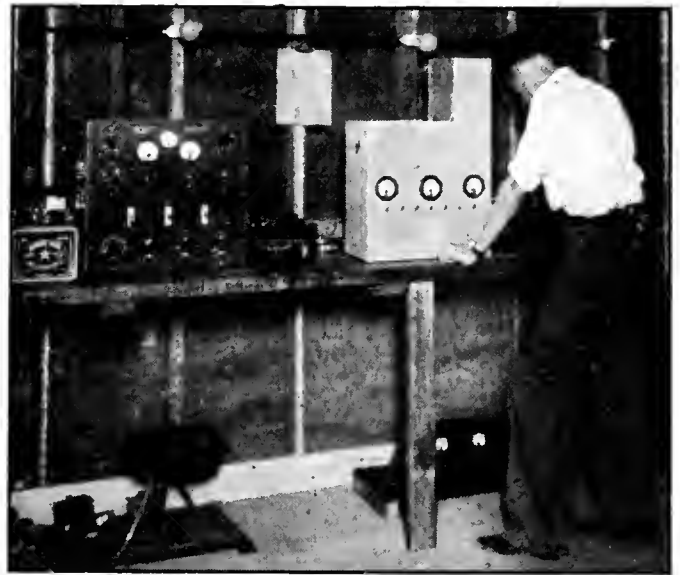

The shielded room in which television signals are measured at the Jenkins Television Corp.

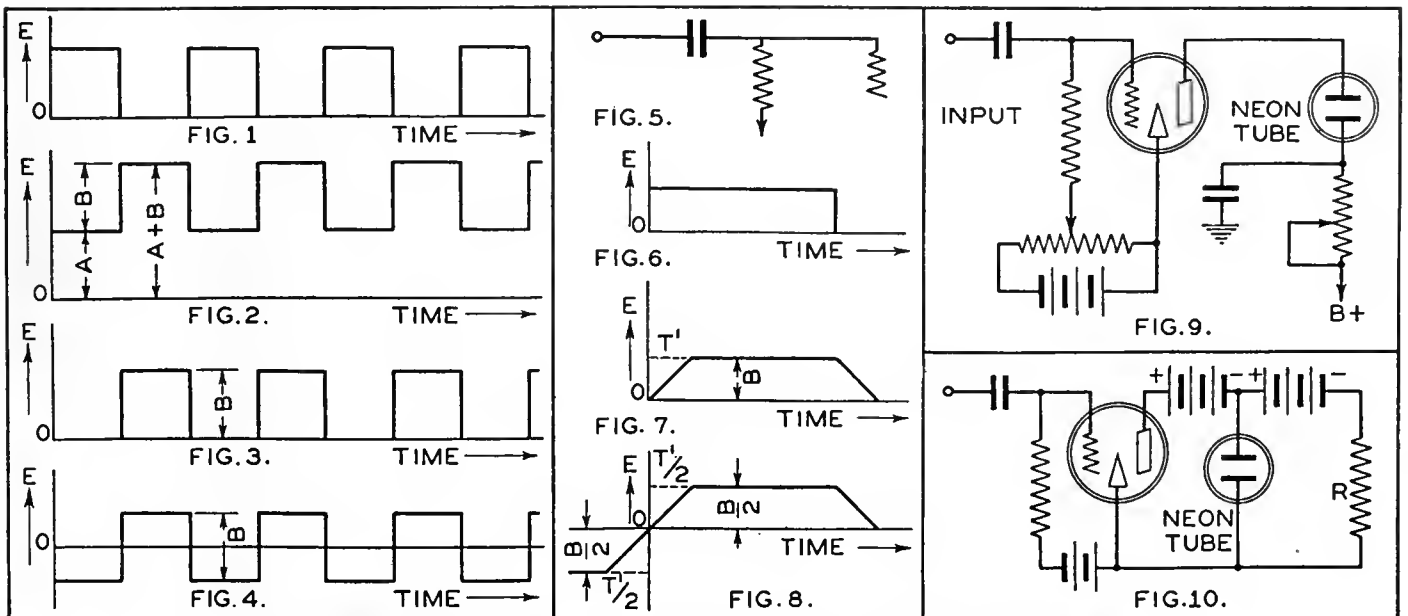

The eight schematic drawings shown above explain the physical aspects of the radio television signal and show two typical neon-tube circuits.

AUTOMOBILE RECEIVER DESIGN

BY ROBERT S. KRUSE.
Radio Consultant

Complete Description and Discussion of the Characteristics of the Bosch Automobile Radio Receiver. Special Problems in the Design of Such Receivers.

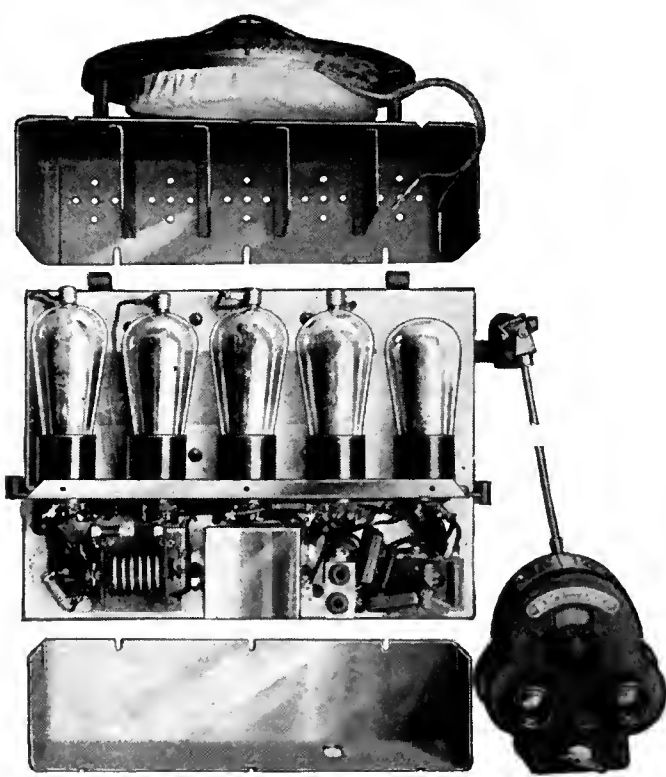

An "exploded" view of the Bosch automobile radio chassis.

THE AUTOMOBILE radio receiver is older than broadcasting. Indeed, the combination of a motor car and a radio receiver was so obvious that many of us made suitable sets in the days when there was nothing to be heard save dots, dashes, and static. When entertainment broadcasting arrived installations were made in larger numbers but without any popular response, despite pictorial publicity in magazines and newspapers. The lack of any general response was due to apparatus limitations, not to any lack in the idea.

Many months ago the Radio Frequency Laboratories, Inc. initiated the familiar process of measurement, calculation, and test which resulted in a working model of a broadcast receiver for use in automobiles. After suitable road and laboratory tests, this model was turned over to the engineering department of the American Bosch Magneto Corporation where it became the basis for additional work. A production model was developed and this also required much measurement and testing by W. F. Cotter and B. V. K. French under the direction of Chief Engineer L. F. Curtis.

This production receiver is discussed in this article. The background for the earlier work on the Bosch automobile receiver may be obtained, to some extent, from reading the paper by Paul O. Farnham, given at the Eastern Great Lakes District Convention, I.R.E., Nov. 19, which will appear shortly in the I.R.E. *Proceedings* under the title "A Broadcast Receiver for Use in Automobiles." A paper on the same subject by W. D. Loughlin has been given limited circulation in the R.F.L. "Preliminary Engineering Report, No. 3."

The Conditions

It is evident that the automobile receiver must operate with a very limited antenna and yet deliver a moderate loud

speaker signal. A very simple calculation shows that the sensitivity must be equal to that of a good broadcast receiver; in other words, the set must have a sensitivity in the region of perhaps 20 microvolts total input when it is giving an output of 80 milliwatts. This rating, not the I.R.E. standard, is used because this power output gives reasonable volume, a departure to be explained later. This performance must be obtained with economy of space, weight, and battery demand. Furthermore, the construction must be dirt-proof and unaffected by vibration, and, auxiliary to the main problem is the need for a semi-remote control and the suppression of ignition noises.

General Arrangement

There are several points of interest in connection with a typical Bosch automobile receiver installation. In the first place, a "roof" antenna is not used and the dash is left wholly unchanged except for the mounting of a small control unit. The set itself is supported by flanges resting in

rubber-lined channels which in turn are carried by brackets bolted to the engine bulkhead. The loud speaker may be mounted directly on the set or may be located in another manner which will be explained in a later paragraph. Unlike some forms of mounting this system does not require reconstruction of the car, nor any special design for a new car. No existing car has yet been found in which the equipment cannot be installed. At this writing all service stations of the American Bosch Magneto Corporation are equipped to make radio installations on all types of automobiles and several manufacturers of cars have listed the set as standard factory equipment.

Collecting signal voltages and at the same time avoiding the pick-up of too much ignition and generator noise is a problem which has caused the appearance of various types of antennas on motor cars for the last 15 years or so. The antenna has usually been concealed in the car roof—certainly the poorest place that could be conceived. Placed between the grounded rooflight and the grounded metal portions of the roof (extended up from the car sides), the effective height cannot exceed a few centimeters. Furthermore, the location is one nearly ideal for the collection of the maximum ignition noise, since the antenna is above and the counterpoise (car frame) below the ignition system. Also, the dome light wiring contributes noise to a roof antenna which is difficult to filter satisfactorily. In addition to this the antenna cannot be installed in a used car except by tearing down the roof upholstery.

The use of the "sub-car" antenna (consisting of a metal plate under the car), shown in Fig. 1, altogether avoids the last difficulty, decreases the ignition noise materially by collecting the signal in the clear space below the car frame, has

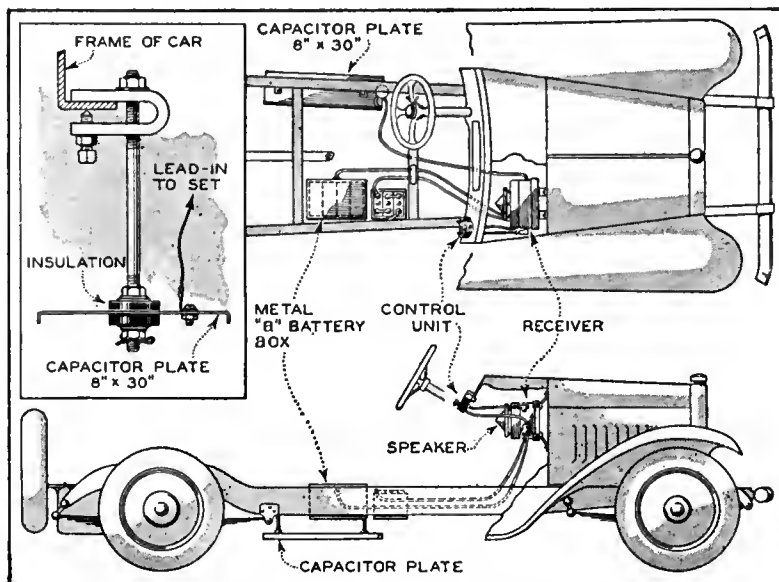

Fig. 1—Schematic drawing of a typical Bosch motor car radio installation.

an equal or better "effective height," and offers a special advantage of its own. This special advantage is that the antenna is near the set and therefore the lead-in wire is short and moderately clear of grounded (connected to frame) metal parts. The capacity of the lead-in wire is accordingly moderate and does not vary extremely from one installation to another, thereby making it possible to secure tuning condenser alignment without the need of anything beyond the normal trimming condenser on each section of the gang variable condenser.

The antenna system is electrically equivalent to Fig. 4, where C_{af} is the capacity between the antenna plate and the car frame, C_{ea} is the capacity between the earth and the antenna plate, and C_{ef} is the capacity between the earth and the car frame. A signal arriving at the car will produce r.f. potentials across all three of these capacities, the combination of which will be effective in supplying voltage to the receiver. In the average installation the antenna-frame capacity, C_{af} , has a value near 0.000125 microfarads, across which is shunted the resultant of the other two capacities in series. This resultant is also about 0.000125 microfarads in the average installation.

Thus the whole is in one sense equivalent to a capacity of 0.00025 microfarads connected across the input terminals of the set. This accounts for the somewhat vague statement on Fig. 5: "Antenna through 250 mmfds."

Actually the r.f. energy is fed from antenna to set through a simple r.f. transmission line, the purpose of which is to permit the transfer to be made at such a low potential that capacity effects are of no importance, regardless of the distance between set and antenna. There is a step-down r.f. transformer at the antenna and a step-up terminating transformer inside the set, the latter appearing as the first transformer in the general diagram of connections, Fig. 3. Between the two transformers is the shielded two-wire line in which the potentials are so low that the length of the line and its location with regard to metallic parts of the car is of little importance. In its present form

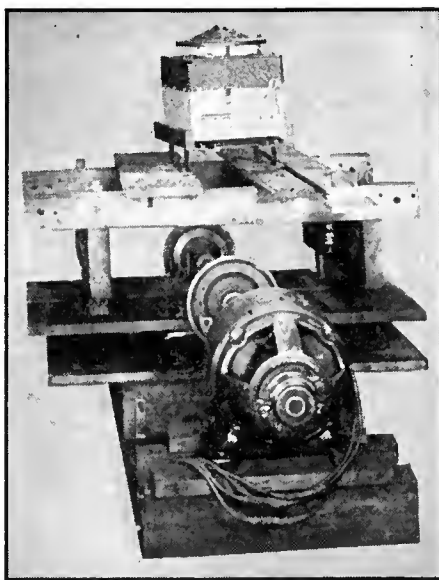

Fig. 2—This apparatus is used to determine the effect of continued vibrations on receiver performance.

this r.f. transmission system produces materially better signal strengths than were obtained with the antenna led directly to the set in the usual manner of motor car sets.

The Receiver

Having arrived at the set we find, as expected, that it is enclosed in a substantial metal case. The design of this case is such that access to the tubes is obtained by loosening three knurled thumb screws and removing the upper portion of the front, which also carries the intertube "fences." There are no loose tube shields or cans. If for any reason the various resistors or by-pass condensers require inspection they may be reached by removing the lower portion of the casing. Both of these points are made quite clear by the "exploded" view of the receiver, the heading illustration. This picture also shows the

arrangement of parts in the lower compartment where the fixed r.f. transformer is located.

In the "exploded" view it will be seen that the upper portion of the casing carries the loud speaker. The tuning control of the set is by means of a gang condenser the shaft of which terminates in a spiral gear, meshing with another gear in the small housing seen at the upper right of the main body of the set. From this point the control is carried to the control head on the dash by means of a splined shaft of adjustable length, connected to the control head and to the set through universal joints. This seemingly complex arrangement was chosen after experience which thoroughly disclosed the unsatisfactory performance obtained from flexible shafts of the simpler design. The principle difficulty about such shafts is that they introduce considerable "slack" or "give," making it impossible to calibrate the dash control, since a station tuned-in at 56 when turning in one direction may appear at 51 when tuning in the reverse direction. In addition to this there is the troublesome tendency of the usual flexible shaft to "wind up" and then suddenly "flip" the tuning unit in the set forward, making it difficult or impossible to stop at a desired point.

The right-hand knob on the control head operates the vernier dial, which is of the "line-of-light" type. This type of dial permits correct reading from any position in the car. The opportunities for parallax with ordinary dials are excellent and the precaution is worth while since it is risky for a driver to lean to the right in reading the tuning scale. The translucent scale, though having only 100 divisions, covers an arc of 312 degrees, thus providing great ease of tuning. To provide this ease of adjustment a reduction of 3.25 to 1 is introduced between the tuning knob and dial scale and an additional 5.6/1 reduction is placed between the tuning knob and three-gang condenser. The left-hand knob on the control head operates the volume control rheostat and at the lower center of the control head is a key-switch which may be used to lock the set when desired.

The design of the set is such that during

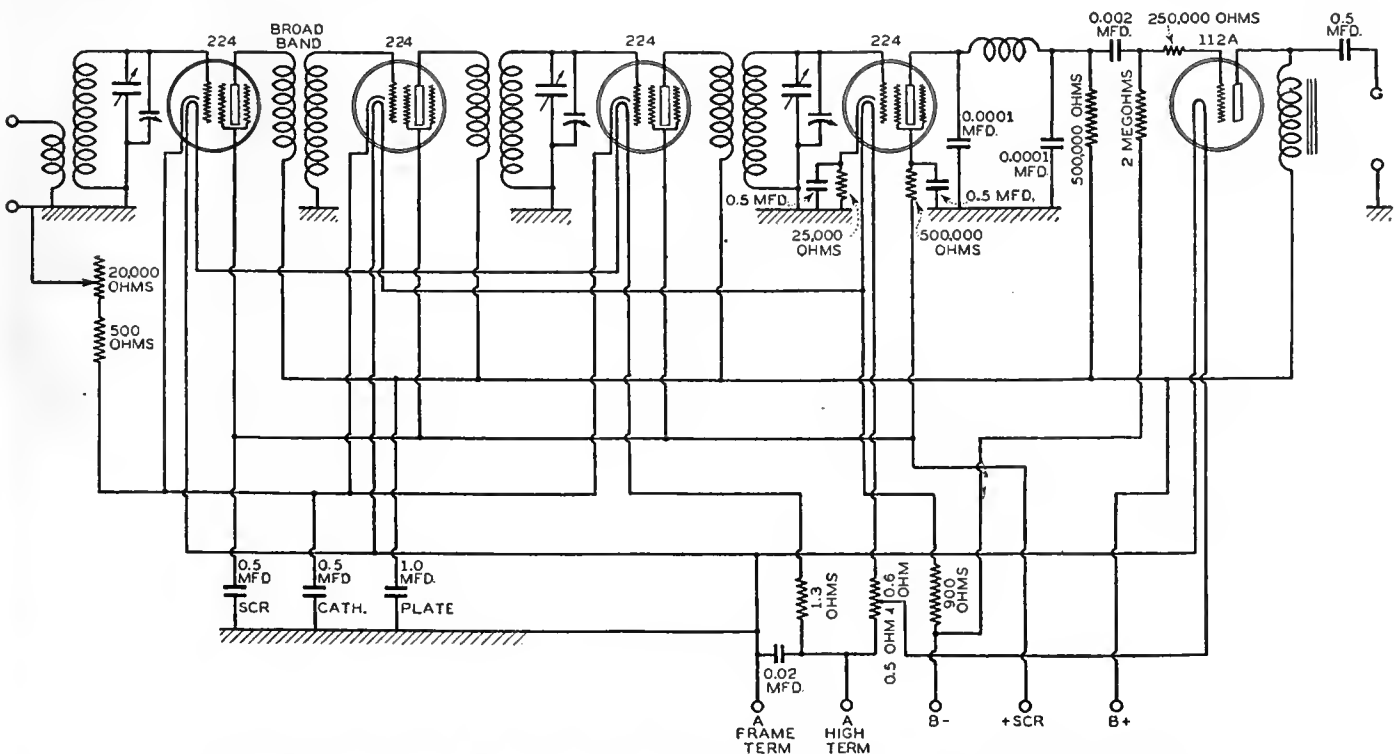

Fig. 3—The complete schematic diagram of the Bosch motor car receiver chassis.

manufacture it may be sub-assembled, the main set body forming one assembly with the tuning gang-condenser in place, while the second assembly consists of the section carrying sockets, r.f. transformers, output choke, and the various resistors and fixed condensers. The removable portions of the case are handled independently, as are the control head and the control shaft.

The design of the mounting brackets is such that when desired the set can be removed from the car either with or without the brackets. The alignment condensers are accessible when the set is in place.

The Circuit

To be of any real use to the average automobile owner an automobile radio receiver must not merely perform within 40 or 50 miles of a station but must be useful in a goodly percentage of all the possible locations in the United States, at least. It has been said that under motor-car conditions this calls for sensitivity of the order of 20 microvolts at the antenna, for 80 milliwatts of audio-frequency output. This performance calls for a voltage gain in the vicinity of 2,000,000 between antenna and loud speaker, using the customary reference to equal impedances at input and output. This may be obtained in a reasonable number of stages with screen-grid tubes by allowing some of the gain to take place in the detector and audio-frequency amplifier.

The first question to be decided is that of the number of r.f. and a.f. stages to be employed. By general agreement a single a.f. stage is preferable if the amplification of the r.f. system is adequate. On the other hand, multiplication of the r.f. stages cannot be carried to extremes since this tends to increase the size of the set by adding bulky r.f. transformers and condensers. In the Bosch automobile receiver three r.f. stages are used to secure a voltage gain of about 60,000. With 20 microvolts input this amplifier delivers about 0.6 volt to the detector.

From the diagram of connections (Fig. 3) and also the pictures it will be seen that the coupling between the first and second r.f. tubes is of the "untuned" variety. Special design of this broad-band transformer permits a gain-curve which is not only comparable to that of a good tuned transformer as to height but also has an advantageous shape. Inspection of the chart of sensitivity curves (Fig. 5) will show a general tendency of the tuned stages to drop off toward the low-frequency end in the familiar manner. The broad-band transformer is accordingly designed for maximum response in the region of 600 kilocycles, causing a sharp divergence between the "first-grid" and "second-grid" curves, and a nearly flat curve for the antenna. Thus, the fixed coupling is not a mere concession to space limitations but a means of obtaining a desirable response curve for the set as a whole.

The selectivity obtained with three tuned circuits in an amplifier with such high gain would not be satisfactory for ordinary home use. It is to be remembered, however, that the pick-up is very limited and the general level quite low so that the "useful selectivity" (the term is admittedly home-made) is entirely satisfactory.

The construction of the broad-band

transformer is simple. It consists of a grooved form in which two wires are wound together, one later to act as primary and the other as secondary. The winding is a "random" one. The purpose of winding in a number of slots instead of a single large groove is to secure an improved L/C ratio and a higher output voltage for the grid of the second tube. The winding speed, tension, wire size, type of insulation, number and form of grooves and number of

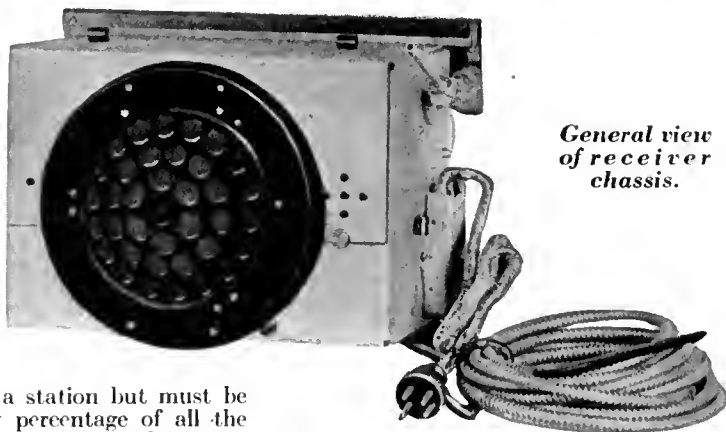

General view of receiver chassis.

turns all contribute to determine the response curve.

The screen grids of the r.f. tubes are maintained at a fixed potential by a tap from the plate battery at 90 volts. Control by variation of the screen voltage is not regarded as suitable since the sensitivity of an r.f. amplifier varies in anything but a linear manner when the screen voltage is changed. The control is accordingly referred to the cathode bias which is obtained by plate-current drop through an adjustable resistor in the control head. This rheostat has a maximum value of 20,000 ohms, which is adequate in the presence of very strong signals. In series with the volume-control resistor is a 500-ohm fixed resistor to provide a minimum bias suitable for weak signals.

Detector and A.F. Amplifier

The fourth screen-grid tube is operated as a "plate" detector and adds somewhat to the overall r.f. gain. The cathode bias of this tube is obtained in the usual way through IR drop. The screen-grid is supplied with a positive bias from the same battery tap which feeds the other screen grids in the set. However, an 0.5-megohm resistor is placed in the lead to the screen grid causing the bias to assume a "rest" value below 90 volts. For low signal levels on the detector-grid, the screen-grid voltage is such as to provide maximum sensitivity. For strong signal levels, the d.c. screen-grid voltage, as well as the d.c. plate voltage, is lowered so as to maintain a reasonably large margin of difference. In this way a higher audio-frequency output may be obtained before the plate circuit of the detector is overloaded. At the same time, for large impressed signals, the response of the detector will be nearly a linear function of the input voltage.

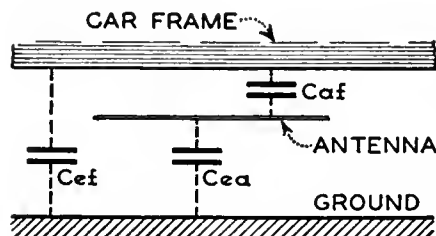

Fig. 4

Where space and weight limitations are as severe as in the automobile receiver the most practical coupling to follow this type of detector is the resistance-capacity-resistance type. In order to prevent radio-frequency feedback originating in the detector plate circuit and coupling with the r.f. amplifier, a "PI" section filter is inserted at the plate of the detector tube. This filter consists of an 11-millihenry choke and two 0.0001-microfarad condensers. In series with the grid of the audio-frequency tube is placed an 0.25-megohm resistor, the function of which is to modify the character of an audio-frequency overload in the grid circuit of the last tube, and incidentally to provide another section of r.f. filter in the detector plate circuit. The effect is quite unmistakable and immediately calls attention to the volume control, but does not mistreat one's ears as unmercifully as an ordinary overload. This is not equivalent to saying that the full output of the tube is in any way sacrificed. On the contrary, the tube is being operated with 180 volts on the plate, with proper grid bias, and is as thoroughly capable of delivering its rating as in any other receiver.

The Audio Level

Most motor cars have closed bodies and the automobile receiver designer assumes such a body in making his design. Even a large sedan is very small when considered as a room and the sound levels to which we are accustomed may be obtained with a relatively small a.f. output from the set and loud speaker. In addition to this, the dimensions of the ordinary car are such as to introduce a tendency towards strong low-pitched resonances. This can be understood easily by recalling the deep rumblings of many sedans of 5 or 6 years ago. In such a space a normal a.f. system would be wholly intolerable; in fact one may say that a good a.f. system for this purpose must be one which will sound very weak on the low notes when operated in the open. This is fortunate since the low notes are the ones which usually enforce the use of large output tubes with their resultant heavy battery drain and bulky loud speakers. Since dry-cell batteries must be used in the present automobile receivers it is most fortunate that the conditions not only permit the 112A-type tube but almost enforce its use—especially as its gain is some three times that of the 171A-type tube.

Special Circuit Features

Some motor cars have the negative terminal of the storage battery "grounded" to the frame, while others ground the positive. Provision is made for this by a circuit arrangement shown in the general circuit diagram. The B— is not returned to the A battery but to the junction point of one of the series pairs of 224 heaters. Thus if we assume the A battery to be reversed the bias of the 112A tube will simply be shifted from a point $2\frac{1}{2}$ volts removed from A+ to a point $2\frac{1}{2}$ volts removed from A— or a total shift of approximately 1 volt. Even at the "Battery gassing" potential of $7\frac{1}{2}$ volts the 112A tube filament operates at a voltage very slightly above 5, hence the change in bias is negligible. The plate voltages are all changed slightly but the percentage is unimportant, as is the change in screen-grid voltages. The cathode bias of the 224-type r.f. tubes is changed very slightly but this merely necessitates altering the setting of the gain (volume) control for a given signal. Even for weak signals the change is small enough to escape notice under ordinary conditions.

It is accordingly satisfactory to install the set "as is" in any car regardless of A

battery polarity, simply grounding the "frame." A terminal and connecting the "high" terminal to the remaining side of the A battery.

The choice of the proper audio-frequency output tube has been discussed sufficiently, and the 112A-type tube is considered satisfactory from all standpoints, including filament demand. In the r.f. portion of the system the present standard types of tubes leave no choice except that between the screen-grid 222 type and the screen-grid 224 type—since the 201A and similar tubes are clearly incapable of providing a gain which will give comparable performance. The 222 is somewhat attractive because of its low filament demand but its extremely microphonic nature and associated fragility rule it out. Also, like the 201A, it is rather hopeless in a situation where the A potential varies rapidly from 6 to 7½ volts as the engine speed changes. Both the 201A and the 222 will follow these voltage changes rapidly and give intolerable shifts of intensity unless specially protected. Of the present tubes the 224 is by far the best. The considerable time-lag of the heater-emitter system comfortably smoothes over the voltage fluctuations, also normal performance of the tube can be obtained over a wider range of fixed voltages than is possible with the 201A or 222. Thus a partly "flat" battery or one being steadily overcharged is not fatal. The use of three 224 heaters in series has been proposed repeatedly, but when the IR drop in the leads is allowed, such an arrangement is on the ragged edge and will drop rapidly in performance whenever the battery is "down."

The 0.02-microfarad low-inductance condenser across the A battery terminals of the set is an r.f. bypass.

The Loud Speaker

The loud speaker is a free-edge cone designed for motor car conditions; that is to say, for such a response-curve as will result in satisfactory reproduction inside a motor car, and to survive the severe mechanical and climatic treatment received. It is enclosed in a stamped steel shell, strong enough to stand up under accidental kicks and jars when mounted on the set under the cowl, but so finished that it presents a good appearance when mounted on the ceiling or in an upper rear corner of the car. The cone itself is waterproofed and survives exposure to sprays. The perforated rear shell is constructed in a manner which provides a sufficient number of openings to prevent resonances inside the shell. Dirt and bugs are prevented from entering through the openings by a cloth sack which is shown in place in the exploded view of the set. By careful design the overall thickness of the shell has been kept down to 2½ inches. When mounted on the set the whole projects but 10 inches from the bulkhead. This sounds larger than it is—or rather the space under the cowl is larger than one ordinarily thinks. The leg room in a small car such as the Essex coach is not noticeably interfered with by such an installation.

A bracket is supplied with the set by means of which the loud speaker may be mounted on the ceiling or in any other position in the car interior. A phone cord is also provided so that the loud speaker may be connected to the set as before by means of the same pin jacks. The loud speaker lead does not carry the plate supply voltage and may be run as desired.

For compactness the location of the loud speaker on the set is an advantage but there are acoustic difficulties. The space under the cowl tends to cause "boomy" resonances; also there may occur what we have called "overcoat attenuation," whenever the right-front seat is occupied

by anyone wearing a heavy overcoat which obstructs the free radiation of sound. This is most noticeable in the rear seat.

Battery Supply

The filaments are supplied through an armored cable from the car's storage battery. The plate supply is obtained from four medium-duty 45-volt B battery blocks carried in a metal battery box under the car, as shown in Fig. 1. This box has a

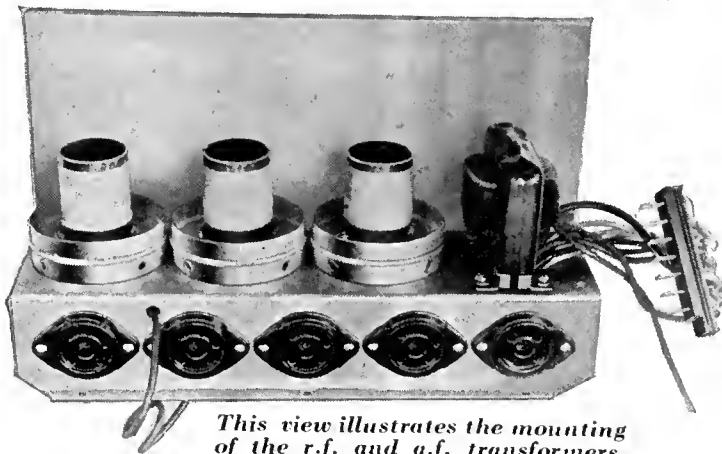

This view illustrates the mounting of the r.f. and a.f. transformers.

gasket to make it weatherproof. The cable to the set is again an armored one. The total filament current taken from the car's battery is 3.75 amperes.

Ignition Interference

Even with sets of very modest performance, motor car installations have been characterized by extensive ignition shielding and numerous by-pass condensers under the hood. These things are almost unnecessary in Bosch installations, despite the unusually high amplification. This has been partly accounted for by the collector system and the armored cables from batteries, as well as the metal case for B batteries. The A battery by-pass condenser at the set contributes also. As the writer has said many times in other papers, the electrical disturbances set up by a motor car are mainly on wavelengths below 10 meters. A broadcast-wavelength receiver with good selectivity, well shielded, and maintained well away from any tendency toward oscillation is inherently rather opaque to such disturbances.

However, the severity of the interference may be reduced greatly by introducing a high resistance between the spark coil and the distributor and the distributor and spark plugs, thereby making the dis-

charge assume the form of a pulse rather than a train of oscillations. Such resistors are supplied with the set. They have standard terminals and are readily applied.

Since dirty charging-generator commutators may cause noises, or disturbances may wander into the set from the ignition switch, a pair of by-pass condensers is provided for shunting across these two units.

There is no other shielding or alteration of the ignition system, yet the noise level

with full sensitivity is barely perceptible at the low-frequency end of the tuner scale and rises at the high-frequency end only sufficiently to permit one to hear it with the car stationary and no signals arriving. The level is lower than that of the hum from a good a.c. receiver.

To test the effect of continued vibration without unreasonable delay the machine

shown in Fig. 2 has been used. It consists of a spring-mounted platform which carries two hearings in which revolves a shaft carrying an eccentric weight. The shaft is revolved at 1800 r.p.m. by means of a flexible shaft connected to the motor. The set is secured to the spring-mounted platform, either in the position shown or in the normal mounting position. The present construction survives this vibration test indefinitely without damage to either set or tubes.

Many road tests have been made over trips of some length. Also there has been much testing in and about different cities, as many sets will certainly be used principally under city conditions.

Because Hartford, Conn.—the writer's home town—is universally considered a radio "hole," the Bosch receiver has been tested repeatedly in this vicinity. The scene of the first tests was a location romantically named "Buena Vista" and considered good—for Hartford. Here it was found that good loud speaker volume could be obtained from WBZ at Springfield, Mass. (27 miles), WJZ, Bound Brook, N. J. (100 miles), WNAC, Boston (perhaps 110 miles), WGN at Chicago (900 miles), and WMAQ, also at Chicago. Several other stations, received rather well, were not identified for lack of time.

It is usually rash to predict radio results by analogy. However, the writer has been carrying receivers about by bicycle, train, wagon and motor car for the past 19 years and during this haphazard exploration of some 25 states has gained much confidence in the belief that Hartford stands well down at the bottom of the scale of radio reception. It seems not too rash to suggest that the quite good performances obtained in many tests about Hartford are reliable indicators of a materially better performance at almost all other points, an opinion confirmed by a number of other observers.

Speaking for himself, the writer offers the opinion that at a majority of the places in the United States satisfactory entertainment-reception would be possible during the hours when any amount of broadcasting is going on—assuming always that there is no local thunderstorm and that the road is not too villainous. If the prediction has the sound of a free advertisement, let it be so. I assure you that it is actually quite free, and given in appreciation of a really nice piece of work.

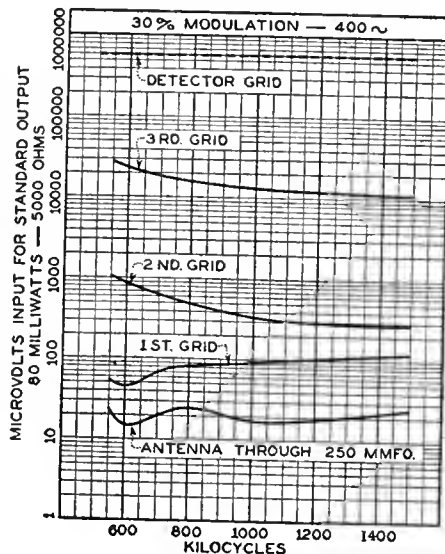

Fig. 5



Rear view of audio-frequency voltmeter.

Some Developments in HIGH-FREQUENCY MEASURING EQUIPMENT

By H. D. OAKLEY

General Electric Company

which measurements on a.f. amplifiers are made.

Audio-frequency amplifiers make use of vacuum tubes and, when making measurements to determine their characteristics and power output, it is usual practice to terminate the amplifier (i.e., load the output tube) with a resistor the value of which is specified by the tube manufacturer. It is convenient, therefore, to have a variable resistor with which any value of resistance likely to be used in the measurements can be easily and quickly obtained. Also when using a resistance load it is wise to supervise proceedings with a loud speaker or a pair of phones connected across the load resistor—being certain,

however, that the impedance of the loud speaker or phone circuit is many times that of the load resistor so that no appreciable errors will be introduced in the measurements. There is still another condition encountered in this class of measurement. It has to do with the type of output circuit used in the amplifier. For example, in some amplifiers the d.c. supply for the last tube passes through the load resistor but in others it does not. When this second condition prevails, the supply must reach the tube through a high-impedance reactor and the load resistor must be connected to the output tube through a low-reactance capacitor. The circuit for this second condition is called the shunt-fed type, the first being the series type.

The loading device attends to all these little details. It consists of a decade resistor box with which any desired value of load resistance can be obtained, a large reactor and large condenser for shunt fed circuits, pin jacks for a loud speaker, a 100,000-ohm resistor which can be included or excluded from the loud speaker circuit, and two key switches. Each switch has three positions, those for one being "Choke," "Neutral," and "Resistance," and for the other "Monitor," "Neutral," and "Loud speaker." On the front of the loading device are two binding posts marked "High" and "Low." The output terminals of the amplifier upon which measurements are to be made are connected to these. Fig. 2 shows five circuits which may be obtained with this device and it also indicates the positions of the two key switches for each circuit.

Circuit No. 1 (Fig. 2) is the shunt-fed type with the loud speaker monitoring connection and is obtained by throwing

one switch to the "Choke" position and the other to the "Monitor" position. Notice that there are 100,000 ohms in series with the loud speaker, thus preventing the loud speaker circuit from producing an appreciable effect on the load of the amplifier under measurement, since the load resistance never exceeds the value of 10,000 ohms and is usually around 4000 ohms. It is obvious from Fig. 2 how the other circuits are obtained and it is only necessary to name the circuits. Circuit No. 2 is the series circuit with monitoring connection; Nos. 3 and 4 are, respectively,

WHILE ENGAGED in activities concerned with the development of audio-frequency amplifiers it is necessary to have at hand apparatus by which the values of input and output voltages of the amplifier can be determined. There is very little difficulty associated with input voltage determinations. It may be accomplished, for instance, by measuring the audio-frequency current flowing through a resistor of known value across which are connected the input terminals of the amplifier, the voltage being the product of the current and resistance. But determinations of output voltage are not accomplished as easily. To the output terminals of an amplifier is connected a load which in measurement practice usually is a resistor, and in service some sort of loud speaker. Now any device placed across this load for the purpose of measuring the voltage across it must satisfy three conditions: the current passed by the device must be very small compared with that flowing through the load; the indications of the device must be independent of frequency over the audio-frequency range (30 to 10,000 cycles); and the indications of the device must be controlled by the effective rather than by the peak or average value of voltage across the load.

A voltmeter has been developed to satisfy these three conditions and also to cover a sufficiently large range of voltages to adapt it to measurements identified with phonograph and broadcast amplifiers.

The two pictures accompanying this article show the external appearance and the arrangement of the various parts of the voltmeter. An additional feature of this apparatus is a unit called the load device. This occupies the bottom panel of the voltmeter. The usefulness of this device may be judged from a consideration of the conditions under

Voltmeter Errors

ERRORS DUE TO MULTIPLIER RESISTOR		
Multiplier Ratios		Per Cent.
Nominal	True	Error
1	1	0
2	2.001	0.05
5	4.98	0.4
10	10.01	0.1
20	19.90	0.5
50	49.7	0.6
100	99.3	0.2
200	199.0	0.5

FREQUENCY ERRORS

Frequency in Cycles		
Meter Reading	Per Cent. Error	
30	0.875	2.8
60	0.892	0.9
80	0.897	0.33
100	0.900	0.00
200	0.901	0.11
500	0.902	0.22
1000	0.905	0.44
2000	0.905	0.44
5000	0.905	0.44
7000	0.905	0.44
10000	0.900	0.00

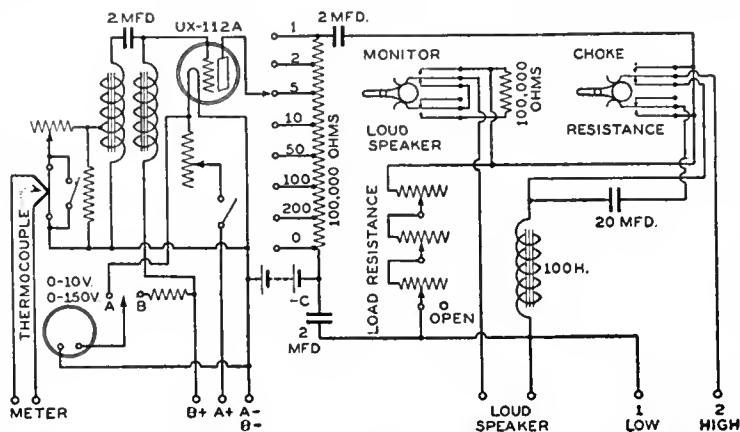

Fig. 1—Circuit of A.F. voltmeter and loading device.

PART II

A Description of the General Electric A.F. Voltmeter Used in Connection With the Generator Equipment Described Last Month. Part III Will Consider the Attenuator.

the shunt and series connections but with a loud speaker instead of a resistance as the load; and No. 5 is the calibrating or cut-out circuit. With circuit No. 5 all parts of the loading device are cut out and the voltmeter terminals (1 and 2) are connected directly to the high and low binding posts of the loading device. With this circuit calibrations of the voltmeter can be made, or voltage determinations effected with the voltmeter operating independently of the loading device.

The middle panel contains nothing but the plate battery of the voltmeter tube. The six-volt filament battery is external and is connected by a cable.

The Voltmeter Panel

The top panel contains all the units which constitute the voltmeter, with the exception of the indicator. This is a microammeter connected to the voltmeter by a cable.

The voltmeter proper consists of three parts; an amplifier, a multiplier, and an indicator. The amplifier is a single tube whose bias voltage, plate-load impedance, and plate voltage are so related that it operates as class "A" or linearly. In other words, conditions have been fixed so that when an alternating voltage is impressed on the grid of the tube there appears in the plate circuit a current whose shape is identical with that of the impressed voltage and the ratio of whose amplitude with respect to that of the impressed voltage remains constant as the amplitude of the voltage is changed. Now if there be placed in the plate circuit a device that will measure the effective value of this current, and if the proportionality factor between the current and the impressed grid voltage be known, then the effective value of the grid voltage is easily determinable. For this device, a thermocouple is employed. It is connected to the plate circuit through a transformer so designed that the proper value of impedance is introduced in the plate circuit to make the tube operate as a linear amplifier. The circuit diagram (Fig. 1) shows a switch connected across the heater of the couple. This is for protecting the heater from excessive currents that may exist while adjustments are being made during a series of measurements.

The voltmeter indicator,

a microammeter, is connected to the junction of the thermocouple. The scale of this meter has been marked in terms of volts; the full-scale mark is 1 volt and the lowest 0.2 volt.

A range of 0.2 to 1.0 volt is not sufficient to endow the voltmeter with any great amount of usefulness in amplifier measurements so there has been provided a multiplier with which the range has been extended to 200 volts. This is a resistor provided with a number of taps which are brought out to the contact buttons of a switch. The voltage to be meas-

ured is impressed across the entire resistor and by means of the switch the grid of the voltmeter tube is connected to that part of the resistor across which there exists a potential of not more than one volt. The taps have been calibrated so the ratio of the voltage across the whole resistor to that across the tap is known. Therefore, to determine the value of the voltage impressed across the resistor it is merely necessary to multiply the scale reading of the indicating meter by the value of this ratio. To build a satisfactory multiplier required very careful design. Its total resistance (100,000 ohms) has to be high enough so that it does not affect the circuits to which it may be connected. It must not possess either inductance or capacity, otherwise its tap ratios would be subject to variations with changes in the frequency of the impressed voltage. The multiplier as finally developed fulfilled these conditions in a very satisfactory manner. The tap ratios have been adjusted to the values of 1, 2, 5, 10, 20, 50, 100, and 200. These give a nice overlapping of readings on the meter so that when going from one tap to the next readings at the extreme ends of the meter scale are avoided. The zero tap is simply a safety position. When the switch is on this tap the

grid of the tube is short circuited and cannot be subjected to excessive voltages.

There have been included in this article data by which the magnitude of the various errors of the voltmeter can be judged. In service, the greatest errors arise from low plate voltage. Therefore the instrument is equipped with a double-scale voltmeter and two-position switch with which both the filament and plate voltages can be checked. The plate battery is made up of large units and will supply energy for a long period of time before replacement is necessary.

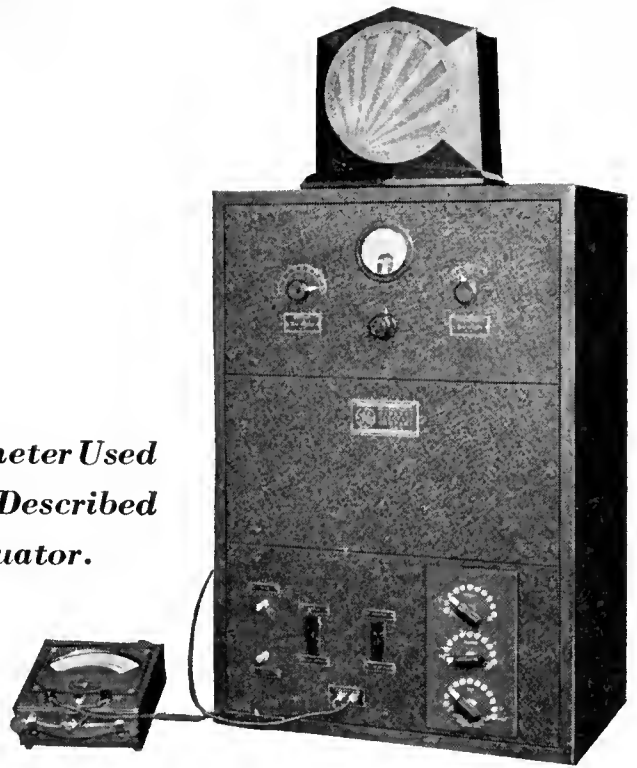

External appearance of the audio-frequency voltmeter.

Voltmeter Errors

INDICATOR SCALE ERRORS
(Frequency of Voltage 100 Cycles)

Input Voltage	Scale Reading	Per Cent. Error
1.0	1.0	0.00
0.9	0.9	0.00
0.8	0.802	0.25
0.7	0.701	0.11
0.6	0.600	0.00
0.5	0.501	0.20
0.4	0.40	0.00
0.3	0.30	0.00
0.2	0.20	0.00

ERRORS DUE TO FILAMENT AND PLATE VOLTAGE VARIATIONS

Filament Voltage	Meter Reading	Per Cent. Error
4.5	0.899	0.11
5.0	0.900	0.00
5.5	0.897	0.33

Plate Voltage	Meter Reading	Per Cent. Error
123	0.82	9.0
135.5	0.90	0.0
147.5	0.955	6.0

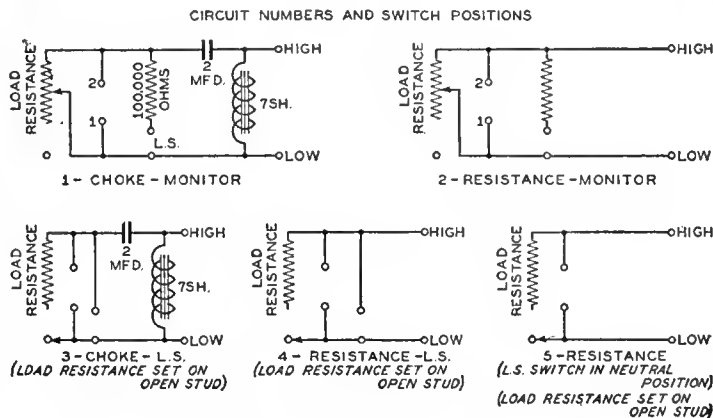

Fig. 2—Circuits obtainable with loading device.

MEASUREMENTS ON BAND-PASS FILTER CIRCUITS

By **W. T. COCKING**

Radio Engineer, The Receptite Co., London.

Mr. Cocking, an English engineer whose writings have frequently appeared in foreign publications, presents in this article the results of some quantitative measurements on band-pass filters with various types of coupling. Although similar arrangements have been thoroughly analyzed mathematically there has been an unfortunate lack here and abroad of definite laboratory data. An article dealing with the mathematical considerations in the design of band-pass filter circuits was published in February, 1930, RADIO BROADCAST, pages 212-214.

IN MOST present-day sets the tuning is carried out by a number of cascade tuned circuits, and, although it is easy to obtain very high selectivity in this way, it is not possible to obtain good fidelity as well, unless a prohibitively large number of such circuits are used.

The band-pass filter, either alone or in conjunction with a number of cascade tuned circuits, offers a solution of the problem, for, when its components have suitable characteristics it gives high values of selectivity without serious suppression of sidebands.

In this article consideration will be given chiefly to the capacitatively coupled filter, as it is usually far superior to the inductively coupled filter. Fig. 5 (A and B) shows two different ways of obtaining inductive coupling, and (C) the usual connections for a capacitatively coupled filter.

Provided that the values of the components are suitably chosen, the results with both types of inductive coupling are absolutely identical; and they may be calculated from the same formula, equation (1) below, and this equation is also applicable for capacity coupling. It is accurate only when both primary and secondary circuits are identical; that is, the total primary circuit inductance must be equal to the total secondary circuit inductance, the total primary circuit ca-

Some Definite Quantitative Figures on Capacitatively and Inductively Coupled Filter Circuits. Band Width as a Function of Circuit Constants. Characteristic Curves With Typical Circuit Arrangements.

capacity must be equal to the total secondary circuit capacity, and the effective, r.f. resistance of both circuits must be the same.

$$e/E = \frac{-X/\omega C}{\sqrt{[R^2 + X^2 - (\omega L - 1/\omega C)^2] + 4R^2(\omega L - 1/\omega C)^2}} \quad (1)$$

R = effective r.f. resistance in ohms of coil, when connected in circuit.

L = total inductance in henries of primary circuit and also of secondary circuit, since both are identical.

C = total capacity of primary circuit in farads and also of secondary circuit, since both are identical.

E = voltage induced in series with primary circuit.

c = voltage developed across secondary tuning condenser.

e/E = gain of circuit.

X = reactance of coupling component,

= ωM for mutual inductance coupling,

= ωL for inductive coupling,

= $-\frac{1}{\omega C}$ for capacitive coupling.

At the frequency at which $\omega L = 1/\omega C$ the formula reduces to—

$$e/E = \frac{-X/\omega C}{R^2 + X^2} \quad (2)$$

and it is obvious that the quantity e/E is greatest when—

$$R = X \quad (3)$$

Substituting, we get—

$$e/E = \frac{R/\omega C}{2R^2} = \frac{1/\omega C}{2R} \quad (4)$$

But for an ordinary series-tuned circuit—

$$e/E = \frac{1/\omega C}{R} \quad (5)$$

Hence the efficiency of the band-pass filter, with optimum coupling, is exactly

one-half of that for the ordinary series-tuned resonant circuit.

The usual simple formulas, depending upon the coefficient of coupling, k, for calculating the frequencies of the two peaks in the tuning curve of a filter are inaccurate, since they neglect the effect of the coil resistance. The peaks occur approximately at the two frequencies for which—

$$R^2 + X^2 = (\omega L - 1/\omega C)^2 \quad (6)$$

but if R is high, the term $4R^2(\omega L - 1/\omega C)^2$ in the denominator of equation (1) appreciably affects the peak frequencies, in some cases to such an extent that the curve becomes single peaked.

At any one frequency it will be seen that capacity coupling gives exactly the same results as inductive, since at that one frequency the reactance of the coupling condenser is the same as that of the coupling inductance. The negative sign for capacity reactance makes no difference to the numerical result, for wherever X occurs in the denominator of equation (1) it is always squared. The change of sign in the numerator merely indicates that the output voltages from the filter are in opposite phase in the two cases.

Capacitive vs Inductive

The difference between the two methods of coupling is important in the practical case, where a wide band of frequencies must be covered with a fixed value for the coupling component. It has been shown above, equation (3), that for the optimum coupling the reactance of the coupling

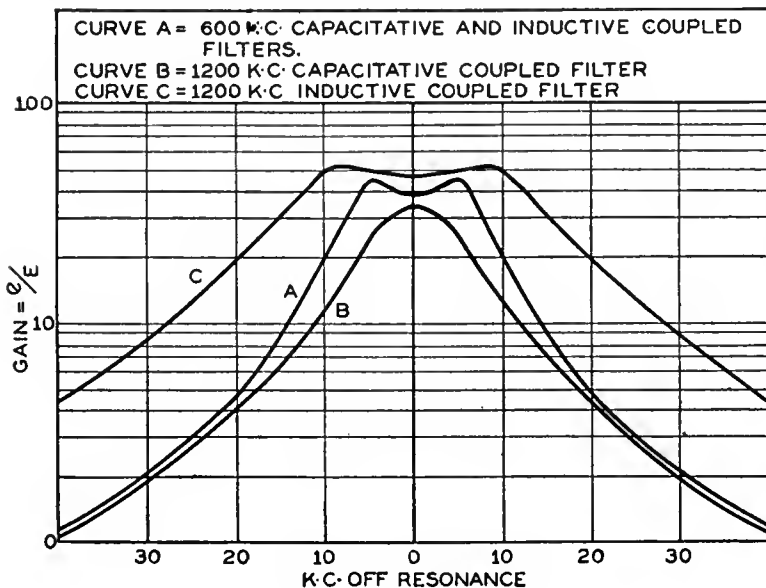

Fig. 1

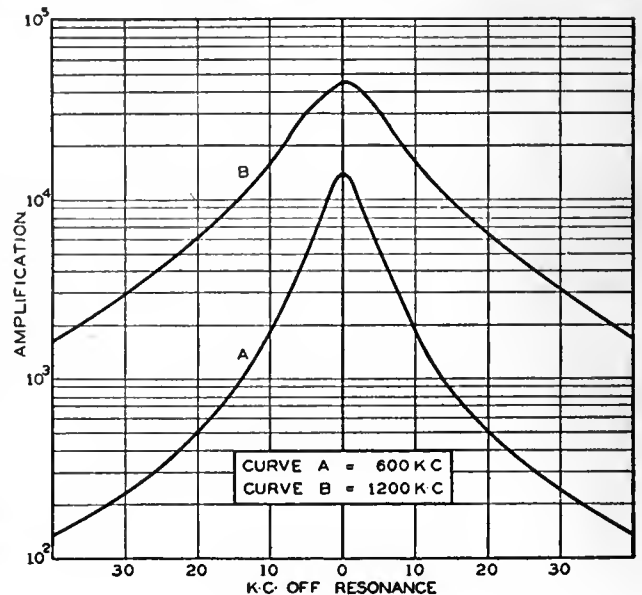

Fig. 2

component must be equal to the r.f. resistance of the coil. Now the latter, with the usual design of coils, varies in a manner roughly proportional to frequency; but the reactance of the coupling inductance is also proportional to frequency. Therefore, the optimum coupling can be maintained over a wide band of frequencies. If capacity coupling be used, however, this is impossible, for the reactance of a condenser is inversely proportional to frequency. It can be seen, therefore, that when it is desired to maintain optimum coupling over the whole tuning range of a receiver, there is no alternative to inductive coupling.

In most cases, however, it is desirable that the coupling should be greater than the optimum, which always gives a single-peaked tuning curve. With a greater value of coupling a double-peaked curve is obtained, and this can be used to compensate the usual loss of sidebands in following cascade tuned circuits. If the peaks are arranged to occur at frequencies 10 kc. apart, audible notes of 5000 cycles will be reproduced at greater strength than notes of 50 cycles; and when this is done, it is obviously desirable that the peaks should occur at the same distance apart over the whole tuning range of the receiver. This, however, is usually impossible.

In what follows it is assumed that tuning is carried out by means of variable condensers; it is not applicable to the rare cases where variometers, or a combination of variometers and variable condensers, are used.

Band Width

At whatever frequency $\omega L = 1/\omega c$, at a frequency 5 kc. different from this the value of $\omega L - 1/\omega c$ remains approximately constant; consequently, the quantity $R^2 + X^2$ of equation (6) must also be constant in value over the whole tuning range of the receiver, if the band width is to remain constant. It will be seen that with inductive coupling this quantity is much greater at high than at low frequencies. Neglecting the effect of the resistance, when the two peaks are 10 kc. apart at a frequency of 600 kc. they will be 20 kc. apart at 1200 kc.; the increased r.f. resistance at high frequencies, which always occurs in practice, increases this variation in band width.

With capacity coupling, however, the case is exactly opposite. Neglecting the resistance, the band width at 600 kc. is double that at 1200 kc.; but in this case, the effect of the resistance is to reduce the

variation in band width. The coupling reactance is smallest when the resistance is greatest, and *vice versa*; consequently, the value of $R^2 + X^2$ tends to remain constant. Indeed, by suitable design of the coils it is possible to make it quite constant, but this is not desirable, since the necessary increase in r.f. resistance at the higher frequencies would make the circuit very unselective. It is quite possible, however, to affect a compromise.

Coupling Variation

When a capacitatively coupled filter is used, however, the coupling does not remain constant; it is considerably less at high frequencies than at low, and this can be used to compensate the low selectivity of both primary and secondary circuits at high frequencies. It is quite possible to design a circuit which will give constant selectivity over the entire broadcast band

Table II—Characteristics of English A.C. Screen-Grid Tubes

Type	Max. Plate Voltage	Screen Voltage	Grid-plate Capacity (mmfd.)	Plate Resistance	Amplification Factor	Mutual Conductance
Mazda AC/SG	150	60	0.005	800,000	1200	1.5
Mullard s 4v.	150	70	—	1,330,000	1000	0.75
Cossor MSG-41	150	60	—	200,000	400	2.0
Marconi s.8	150	80	0.014	200,000	160	0.8
Marconi MS 4	150	70	0.0045	500,000	550	1.1

All the above, with the exception of the Marconi s.8 tube, are of the indirectly heated cathode type, with heaters requiring a current of one ampere at four volts; they are fitted to the new English five-pin base. The s.8 tube is of the directly heated type with a filament requiring 0.8 ampere at 0.8 volt; it is fitted to the four-pin base.

From this it would seem that the only difference between capacitive and inductive coupling is that the variation of band width with frequency is less with the former. There is, however, another difference, and this also is due to the difference in the variation of reactance of the coupling components. It is well known that the ordinary tuned circuit is

of frequencies, or even one which is more selective at the higher frequencies.

In order fully to appreciate the differences between capacitive and inductive filter circuits, it is necessary to compare the resonance curves at different frequencies. In Fig. 1 are shown three curves; A is for a frequency of 600 kc. and is for both inductive and capacitive filters,

B and C are for a frequency of 1200 kc. and are for capacity and inductance coupling, respectively. For both filters the coil inductance was 240 mh., the r.f. resistance at 600 kc. was 10 ohms, and at 1200 kc. was 20 ohms. The coupling inductance in the inductive filter had a value of 4.7 mh., and the condenser in the capacitatively coupled filter had a capacity of 0.015 mfd.—values which give the same degree of coupling at 600 kc. The

Table I—Essential Figures for Selectivity, Gain, and Sideband Variation

Description	Frequency	Amplification	Selectivity	Sideband Variation per cent.
Inductive filter	600 kc.	39	33	15
M = 4.7 mh.	1,200 kc.	47	10.5	6
Capacitive filter	600 kc.	39	33	15
C ₁ = 0.015 mfd.	1,200 kc.	33	30	26
Amplifier, two Mazda a.c./SG tubes in tuned plate circuit	600 kc.	14,000	112	61
	1,200 kc.	43,000	25	29
Amplifier and Inductive filter	600 kc.	540,000	3,700	54
	1,200 kc.	2,021,000	262	24
Amplifier and Capacitive filter	600 kc.	540,000	3,700	54
	1,200 kc.	1,435,000	736	47
Capacity filter in antenna circuit, capacity filter in plate of first n.c. SG tube, and tuned plate for second r.f. amplifier. Five tuned circuits in all	600 kc.	234,000	11,600	15
	1,200 kc.	604,000	4,360	54

essential figures for selectivity, gain, and sideband variation are given in Table I.

Greater Selectivity

The immense superiority of capacity coupling is at once evident; both filters give the same results at 600 kc., but at the higher frequency, the selectivity with capacity coupling is nearly three times that with inductive, being 30 instead of 10.5. At 600 kc. it is 33 with both circuits. These figures for selectivity are obtained by dividing the filter output voltage at resonance by the output voltage at a frequency 40 kc. different from resonance, the input voltage being the same for both frequencies. This method of expressing the selectivity is used throughout this article. The amount of sideband cutting is called the sideband variation, and is expressed as a loss in percentage. With band-pass filters it is sometimes a high-note loss and sometimes a high-note accentuation; the upper sideband limit is taken as 5000 cycles. The ratio e/E has been defined earlier, but it must be remembered that it is *not* the actual amplification from the antenna to the grid of the first r.f. tube; the actual amplification depends upon the antenna and degree of coupling to the antenna, as well as the antenna constants.

Returning to the consideration of Fig. 1. It can be seen that the amplification is

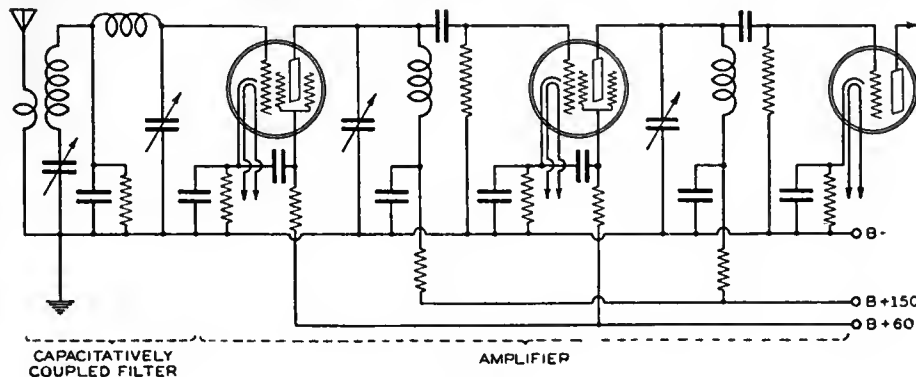

Fig. 3

nearly the same with all three curves, being slightly greater with inductive coupling at the higher frequency. The sideband variation, however, is very different; at 600 kc. it is 15 per cent., and is in the form of a high-note accentuation. At 1200 kc., with inductive coupling it is only 6 per cent., but with capacity coupling there is a high-note loss of 30 per cent. This difference in the amount of sideband variation at different frequencies is not the disadvantage it may at first appear to be; as will be shown later, when considering the applications of the filter to a tuned r.f. amplifier, it is rather an advantage than otherwise.

Coupling Tubes

The band-pass filter may be used with very similar results as a means of coupling two tubes in a r.f. amplifier. It is usually

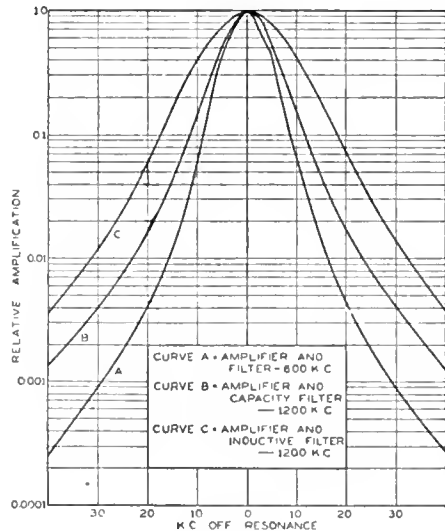

Fig. 4

unnecessary to do this, however, as it is but rarely that more than one filter is needed in a receiver; and if only one filter is used, it should always be included in the antenna circuit, owing to the greater freedom from "cross-talk" which can then be obtained. The formula necessary for calculating the amplification given by a tube with a filter in the plate circuit is given below, where the symbols have the same meanings as before—

$$A = \frac{\mu^2 X^2 C^2}{\sqrt{\left[R_p (R^2 + X^2 - (\omega L - \frac{1}{\omega C})^2) + \frac{L R}{C} \right]^2 + \left[(\omega L - \frac{1}{\omega C}) (2 R R_p + \frac{L}{C}) - \frac{X^2}{\omega C} \right]^2}} \quad (7)$$

A = amplification
 R_p = tube plate resistance
 μ = amplification factor

At the frequency at which $\omega L = 1/\omega C$ this reduces to

$$A = \frac{\mu^2 X^2 C^2}{R_p (R^2 + X^2) + \frac{L R}{C}} \quad (8)$$

since $X^2/\omega C$ in the right-hand bracket of the denominator is usually negligible in comparison with the other terms.

When the tube has a plate resistance greater than about 500,000 ohms, it is sufficiently accurate for most purposes to calculate the *shape* of the tuning curve from equation (1), and the amplification at resonance from equation (8). The results will show the selectivity and sideband variation as being slightly higher than is actually the case, but the error is usually inappreciable. Of course, if the tube has a low plate resistance the correct formula (7) must be used, and this will always give correct results.

Plate-Circuit Filter

The remarks made earlier in this article on the respective merits of inductive and capacitive couplings apply with equal force to the plate-circuit filter. The only difference in the results is due to the damping exerted by the tube's plate resistance on the primary circuit of the filter. If this resistance is high, as it usually is with good modern screen-grid tubes, the difference is very small.

With modern screen-grid tubes, however, sufficient r.f. amplification for most purposes can be obtained with two stages, with the usual methods of coupling the tubes. This amplification is sufficient to permit the use of one filter, but it is not usually great enough if two filters are used; since the loss of amplification in each filter must be at least 50 per cent. The curves of Fig. 2, A and B, show the amplification and selectivity of a particular r.f. amplifier at frequencies of 600 kc. and 1200 kc., respectively. The amplifier, the skeleton circuit of which is given in Fig. 3., consisted of two Mazda AC/SG screen-grid tubes coupled by the tuned plate circuit, with coils having an inductance of 210 mh. and a r.f. resistance at 600 kc. of 10 ohms, and at 1200 kc. of 20 ohms. The tuned plate circuit was adopted because, owing to the high plate resistance of these tubes, no greater amplification could be attained by the use of a transformer nor could the selectivity be increased to any great extent. In addition, the tuned plate circuit allows of very simple switching arrangements being used to change from one wave range to another. This is a very important point in designing receivers for use in England, for every set must be able to receive not only on the normal waveband of 200-550 meters, but on the 1000-2000-meter waveband also. The characteristics of English a.c. screen-grid tubes are given in Table II.

Amplifier Characteristics

It will be seen that the amplification given by this amplifier is very high; at 1200 kc. it is 200 per stage, and this with perfect stability. Now it is obvious that if this amplifier were preceded by a normal single tuned antenna circuit, it would result in poor selectivity at the higher fre-

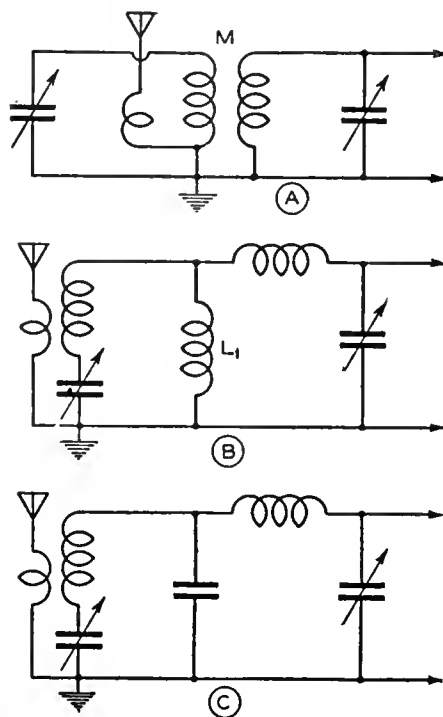

Fig. 5

quencies, for each of the three tuned circuits would give greater selectivity at the low frequencies. In addition, the sideband loss would be far too high, for with only two circuits it is 60 per cent. at 600 kc. The results, when the amplifier is preceded by a filter, however, can be seen from Fig. 4, in which curve A is for a frequency of 600 kc., and for either capacity or inductive coupling in the filter; curve B shows the results with capacity coupling at 1200 kc., and curve C for an inductively coupled filter at the same frequency. It is included so that a comparison can be made between inductive and capacitive coupling. The values of the coupling components are the same as those mentioned earlier. The input voltage for these curves is such that the out-

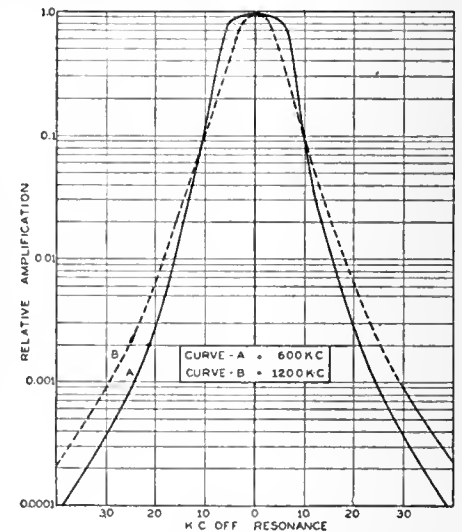

Fig. 6

put voltages at resonance are the same for all three; in this way the differences in selectivity and sideband variation may be seen readily. The figures for amplification are given in Table I, but it must be remembered that these figures show the amplification of the voltage induced in series with the primary circuit of the filter, not the voltage in the antenna.

Selectivity Variation

The superiority of capacity coupling is even more obvious in these curves than it is in those for the filter alone, for the poor selectivity of inductive coupling at the higher frequencies is accentuated by the same defect in the amplifier. With capacity coupling the selectivity varies in a 5-1 ratio between 1200 kc. and 600 kc., but with inductive coupling this ratio is 14-1. Not only this, but an advantage is gained in fidelity also. The high-note loss at 600 kc. is 54 per cent. with both methods of coupling; at 1200 kc. it is only 25 per cent. with inductive coupling, and 47 per cent. with capacity coupling. It is decidedly an advantage that the loss should remain constant over the whole tuning range of the receiver, for it makes it possible to compensate it by increased amplification of the upper audible frequencies in the a.f. amplifier. Although, with the loss of 50 per cent. given by this particular arrangement, it is rather doubtful whether any great increase in fidelity would result from such compensation, as the ear is very tolerant of a high-note loss. It is probable that a loss of this order is unnoticeable by the average ear.

The curves of Fig. 6 show the results to be expected from the same amplifier, but with a capacitatively coupled filter substituted for one of the tuned plate circuits.

(Continued on page 349)

THE INVESTOR LOOKS AT RADIO

By **BERKELEY A. CATER**

Chief Statistician, Blumenthal Brothers
Members, New York Stock Exchange

The First of a Series of Articles Considering the Speculative and Investment Values of Radio Stocks. This Installment Considers Conditions in General; The Next Article Will Analyze the Position of R.C.A.

IT IS PROBABLE that more money has been made and possible that more has been lost in radio than in any other development in this generation. Surely, any industry which has so profoundly affected so many people is worthy of our brief attention.

The growth of the industry has been truly fantastic and has naturally aroused public interest not only in actual receiving apparatus, but also in securities of radio manufacturers. In many cases large profits were realized, both because of the growth of the industry and the rapidly rising stock market, but in almost as many cases losses were equally great. The unknown element of mystery in radio was indirectly responsible for successful pool operations in many radio stocks, for it is well-known that such operations are seldom successful in stocks lacking an air of mystery, as pool operators work on public fancy rather than facts.

Investor vs. Speculator

If we were to attempt to survey the situation in radio strictly from the investor's point of view we could not proceed much further, for few, if any, of the common stocks of radio companies are entitled to true investment ratings. Admitting that in many cases the difference between investment and speculation is not clearly definable, we believe that to enjoy an investment rating a common stock must (a) participate in the earnings of a stable and necessary industry, (b) pay a reasonable dividend in relation to earnings and market value, and (c) have paid that dividend for a number of years, in depression and prosperity, thus indicating a substantial reserve. A few radio stocks will undoubtedly attain investment rating within a few years; and a few are now reasonably attractive as a speculation for long-term holding. A modification of our title to "The Speculator Looks at Radio" would thus seem necessary. As we are not interested at the moment in any particular company or the advantages of owning a particular set, we shall limit the discussion to the financial condition of the industry as a whole and its prospects for the future.

Although the development of radio in this country has been phenomenal, it has been typical of the extremes of American commercial enterprise, both enjoying the advantages and suffering the disadvantages of our aggressive manufacturing and sales policies. The industry has grown so rapidly that it has suffered from lack of balance and at the moment cannot be said to be in a thoroughly healthy condition. This is in spite of the fact that radio broadcasting and receiving have reached a very high state of perfection in this country and are being improved to fulfill the best artistic and commercial requirements.

Of the 24,000,000 homes in the United States, 12,000,000 or more are believed to be equipped with radio receiving sets. Of the remaining 12,000,000, several million will never be able to afford sets and a small portion will never want them. As the sale of radios in 1929 was estimated at from 3,000,000 to 3,500,000 sets, it is obvious that at this rate of production every prospective purchaser could be supplied within a few years. This growth in the manufacture of receiving apparatus has been far more rapid than was healthy and may be compared to an over-grown child that has not yet reached its strength.

Frequently we are told that without the drastic decline in the stock market, radio sales would have continued to advance as rapidly as in the past, but if we consider the facts as they are, we shall arrive at a less favorable conclusion. It is true that the break in the market did seriously affect sales in November, as compared with October. However, recovery was noticeable in December, largely because of the holiday trade, but it was still not sufficient to dispose of stocks on hand. It is estimated that more than 1,000,000 sets are being carried over which must before long be thrown on the market. [Sale of these sets is felt to be proceeding at a steady and satisfactory rate—*Ed.*] The beginning of this liquidation has already become apparent in some of the larger centers, where radio prices have been cut materially. Although the break in the market with its consequent loss of buying power to the average investor had some effect on radio sales, it may more truthfully be said that it revealed an unsound condition in the industry which would inevitably have become known at a later date, and probably with more unfortunate results.

Industry Problems

The problems facing the industry are therefore (a) to dispose of stocks on hand without a price war, and (b) to improve receiving apparatus so materially either in reception or appearance that the replacement demand will take care of production. That this task will not be easy may be realized when we consider that the combined manufacturing facilities of all companies in the field could produce annually over 15,000,000 sets.

It is possible that the answer to the question lies in sales overseas, especially in countries where the average per capita wealth is high, but there are definite reasons why such sales cannot increase as rapidly as was the case in the domestic market. These reasons are briefly that (a) wavelengths in many countries are dissimilar to our own, necessitating a different type of apparatus, (b) delivery cannot



be made quickly, (c) American manufacturers are loath to extend credit facilities to overseas dealers, and (d) the landed cost of American sets is much higher than sets made by European manufacturers. Although exports of radio apparatus in 1929 reached a total of \$23,122,141, a gain of \$11,060,662 over 1928, the greater part of our exports went to Canada, Australia, and the more prosperous South American countries where merchandise of quality can be sold because of relatively high average wealth.

In Europe the prospects are much less hopeful, for the quality of our merchandise is not as a rule sufficiently better to warrant the extra cost.

A Comparison

The radio industry may be compared in a number of respects with the automobile industry in its early stages. Of the many early manufacturers, only a few of the strongest have survived. Automobiles have apparently nearly reached a state of perfection, changes being of a non-essential nature, such as color or body design, but automobiles of necessity will wear out and must be replaced. The contrary is true of radio apparatus for, with the exception of tubes, and in some cases, batteries, there is little deterioration. Offsetting the fact that radios are much cheaper than automobiles and may reach the saturation point sooner for that reason, is the possibility of further perfection making existing apparatus practically obsolete. In this field lies the hope for the industry. Which tendency will be stronger can be answered only by the course of future events.

Other Weaknesses

Not all the ills of the industry should be attributed to over-production for some companies have lacked one or more of the requisites for success, such as skilled research engineers, good advertising and merchandising policies, and strong financial backing. The market value of the stocks of some companies has been made still weaker by pool operations which in some cases appear to have received the support of the managements, and it is doubtful if any radio stocks have escaped some manipulation. The recent receiverships, of Earl

(Continued on page 345)

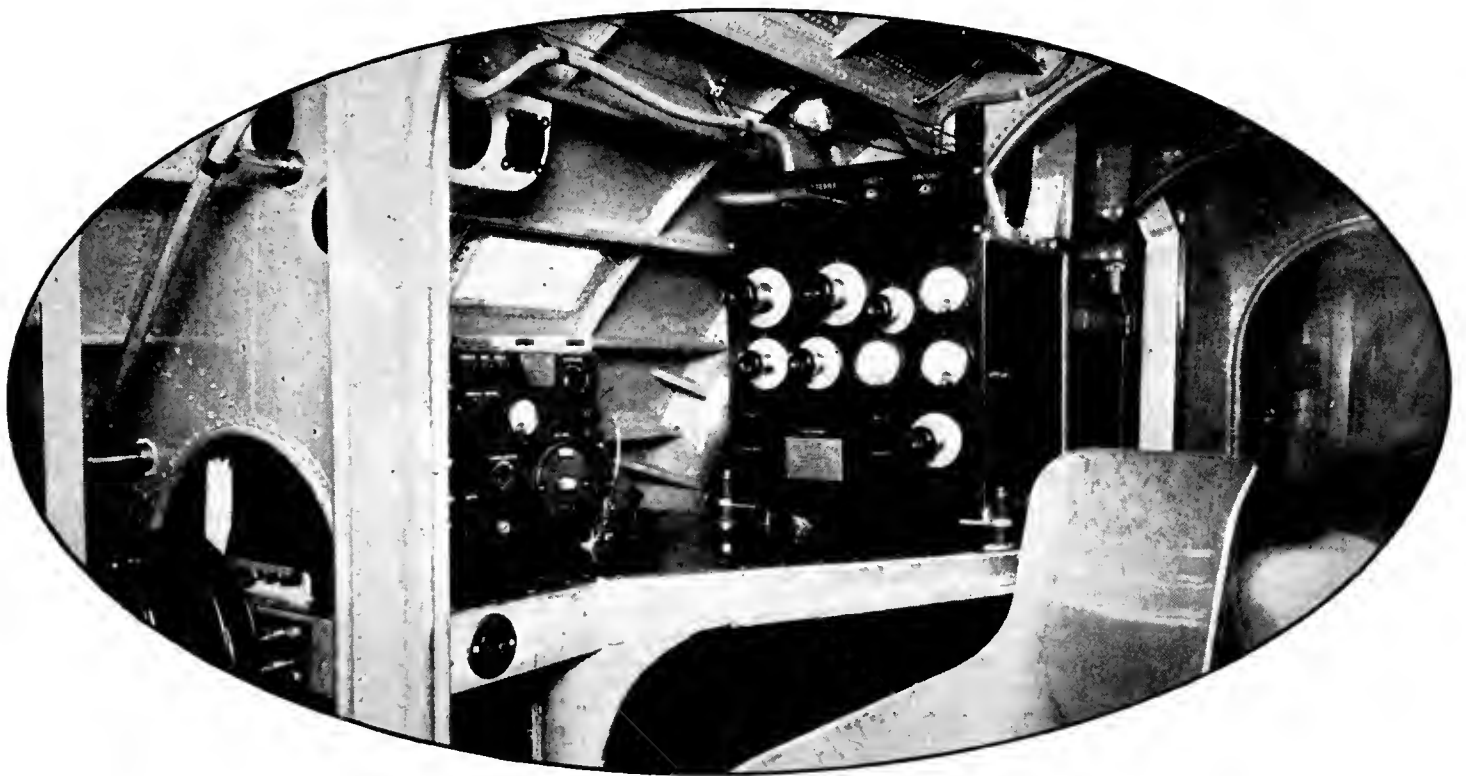

View of radio transmitting and receiving apparatus in a modern Navy airplane.

AIRCRAFT RADIO DEVELOPMENT

A Summary of the Factors Influencing the Design of Aircraft Transmitters and Receivers. General Requirements of Receivers for Aircraft Use. Sensitivity, Fidelity, and Band Width Characteristics of a Typical Receiver.

THE FIRST telephone transmission from plane to ground was accomplished in England during the summer of 1915 by Major Prince and Captain H. J. Round. A cw tube transmitter was used for this notable achievement. Since that time, radio has come to play an increasingly greater part in the development of commercial aviation.

Ignition noise has prohibited the use of highly sensitive receivers until very recently. This necessitated the use of the long, trailing-wire antenna which was unsatisfactory on account of landing problems, time involved in reeling the antenna in and out, frequency variation, losing the antenna, and other factors. Mechanical vibration and noise has made the choice of non-microphonic tubes a necessity. The problems of construction, instrument mounting, and dependability are also dependent upon the extreme amount of vibration encountered. The placement, accessibility, and servicing of the component parts must be considered. The apparatus must be simple and fool-proof, because the average pilot and mechanic are not expert radio operators and only the larger commercial planes can accommodate a special radio operator. Frequency choice is important, and depends largely upon the purpose of the equipment. Continuous communication with ground stations along standard airways must be considered. The apparatus must be able to withstand the unusual climatic, humidity, and temperature changes encountered during any kind of flight. Tuning must be accomplished with heavy gloves at times. A locking device is frequently necessary to prevent "creeping of tuning," especially for beacon work. The apparatus must be extremely light, shock-proof, and compact. The power supply should be such that the equipment can be operated during emergencies, such as a forced landing. Sufficient

By **ELMER L. BROWN**
Engineer, Special Equipment Division,
RCA-Victor Co., Inc.

output of the receiver is necessary for operating a beacon-indicating device.

The trailing wire type of antenna, which has been used until very recently for both

the dirigible type of airship and the heavier-than-air type of craft, had several distinct advantages as well as disadvantages. Its use is confined largely to the lower frequencies, and it is comparatively satisfactory around 300 kc. It is possible with this type of antenna to communicate over compar-

atively long distances with a minimum of power. However, it is necessary to reel this antenna out when communication is desired and to reel it in when communication is finished. The maintenance cost of this type is large, and the hazards encountered when flying at low altitude make it undesirable. It is also impossible to use it when a forced landing must be made. The air resistance of this antenna increases the drag on the ship and materially reduces its speed. It is impractical for military use, as a plane cannot be stunted.

Effective shielding of ignition systems makes it possible to use receivers with a sensitivity as high as 5 microvolts per meter. Sensitivity greater than this is undesirable, as with it one is enabled to get down to the noise level with a short vertical-rod antenna. The vertical antenna is justified by its elimination of physical hazards, burdens of operation and maintenance, and a substantial reduction in beacon errors. A streamlined duralumin vertical antenna 2 or 3 meters in height, triangular and guyed to the upper wing and fuselage, has much less wind resistance than a trailing wire, and is still short enough not to interfere with putting the plane in the hangar. This type is particularly satisfactory for high-frequency work, as it is rigid enough not to cause swinging of the signals. This eliminates the use of a kite for emergency landings as was necessary with the trailing-wire type. A modified T or V type of antenna can be used successfully with larger ships and dirigibles. Almost any type of rigid structure can be used with dirigibles.

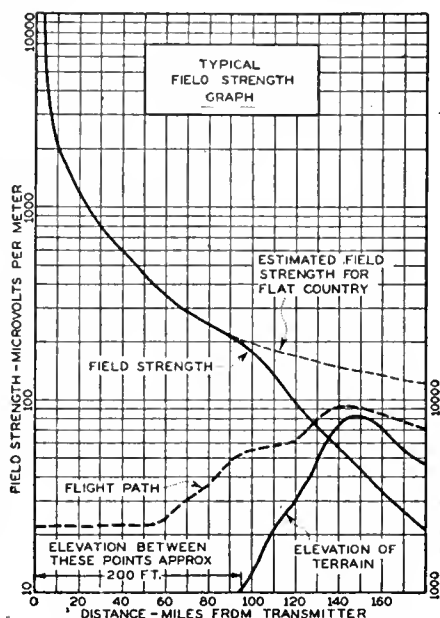

Typical aerial field-strength curve.

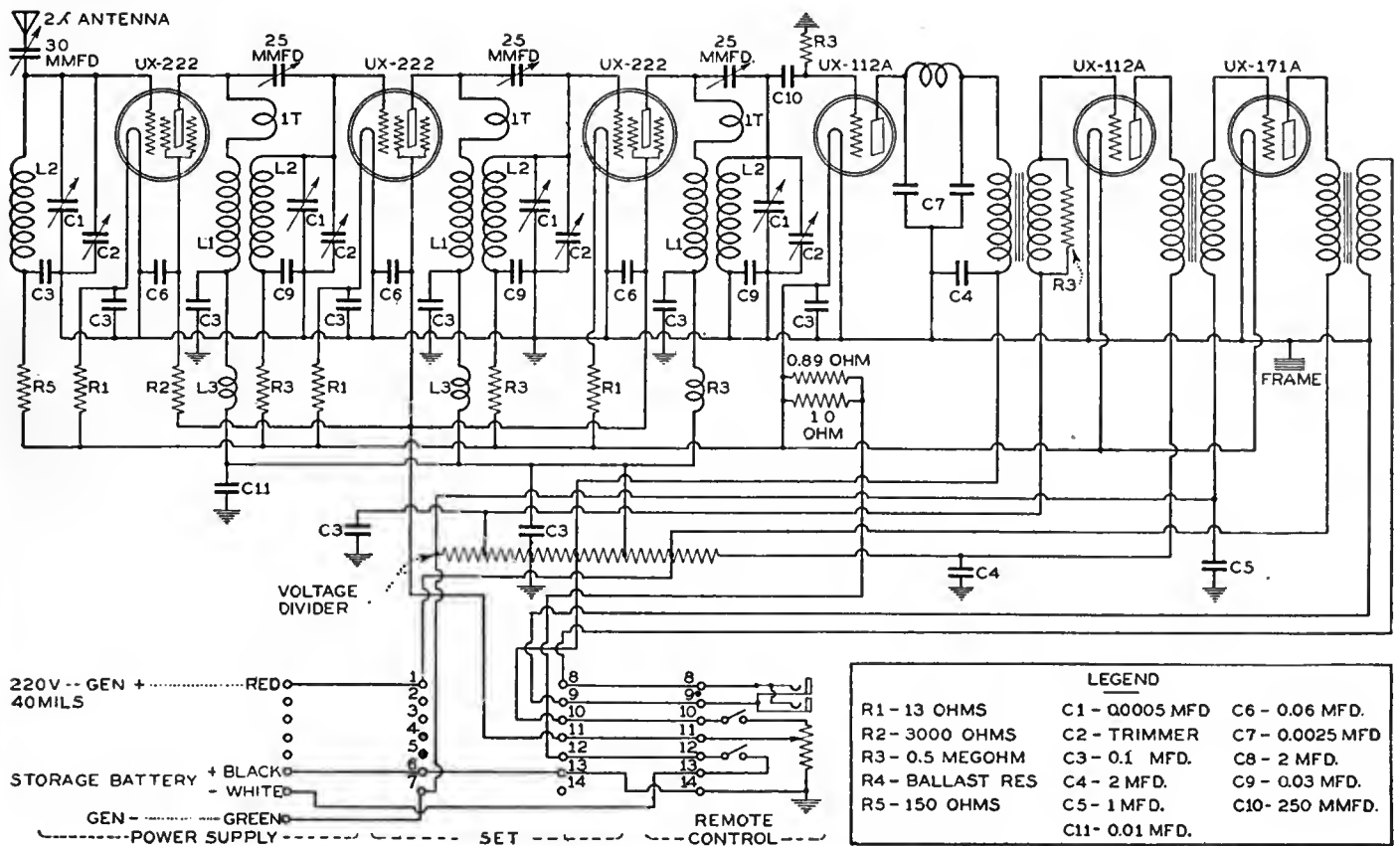

The schematic diagram of a typical air-beacon receiver

Three types of radio receivers are in general use by aircraft. These are:

- (1) Military type that is required to cover a broad band of frequencies.
- (2) The average commercial beacon and radiophone receiver required to cover the comparatively narrow band from 285 to 350 kc.
- (3) The high-frequency receiver that operates on frequencies above 1500 kc.

The first type has rather rigid specifications and usually requires the use of a specialist in operating.

The second type is a standard tuned-radio-frequency receiver, and usually consists of three tuned stages of screen-grid radio-frequency amplification, a detector, and two stages of audio-frequency amplification with sufficient output to operate a beacon-indicating device.

The third type usually consists of a regenerative receiver employing plug-in coils for the different frequency bands and sufficient a.f. amplification for easy reception above the mechanical noises.

The general requirements of a radio receiver for aircraft use are as follows:

1. Single dial control. Fixed tuning.
2. Rugged volume control. Capable of remote installation.
3. Sufficient shielding to limit signal pick-up to that of the antenna.
4. Rugged construction in order to be immune from vibration encountered.
5. Non-microphonic construction.
6. Rigid condenser plates. Wide spacing with plates of at least 0.025-inch stock is usual practise.
7. Non-microphonic tubes. Tubes of the heater type such as UX-227 and UX-224 are particularly adapted for aircraft use.

(The great demand, particularly by the aircraft industry, for a non-microphonic low-current-consumption tube has resulted in the development of the UX-864 type. This tube has approximately the same characteristics as the UX-199, except that it uses an oxide-coated filament requiring 0.250 amperes at 1.1 volts. This tube is extremely rugged, non-microphonic, and

beacon indicator, jack for phones, and necessary cable connections.

10. Of such size and dimensions which permit installation in whatever space is available.

11. Sufficient sensitivity to get down to atmospheric noise level with a 2-meter vertical-rod antenna.

12. Sufficient fidelity. Beacon signals are modulated from 40 to 120 cycles and the voice ranges from 300 to 3000 cycles.

13. Must have sufficient output to operate a beacon course-indicating instrument. Ten volts of audio frequency with a load impedance of 4000 to 7000 ohms is sufficient.

14. A fair amount of selectivity is necessary, although the problem is not yet as bad as that on the broadcast frequencies.

15. A well-designed helmet to exclude mechanical noises. Use of sponge rubber caps is satisfactory.

16. Should be satisfactory for both visual and aural beacon reception up to 150 miles with a 2-kw transmitter on the ground on the 333-kc. band, using an antenna 2 meters high on the plane, and the bonded metal members of the plane for a counterpoise.

17. The total weight, including a 5-pound duralumin antenna and a 10-pound battery, should not exceed approximately 35 pounds. The battery used for the navigating and landing lights may be used for the filament supply of the receiver.

Plate rectification with automatic grid bias is desirable when used with a visual indicator. Reversal or lack of course indications may result if the input is increased through values corresponding to the maxima of the curve into the regions of the negative slope. An automatic bias prevents this. The sensitivity and selec-



View of a wind-driven motor generator.

economical in operation.) It is understood that a complete line of low-current, low-voltage, non-microphonic tubes are being developed.

8. Accessibility or ease of servicing. The receiver mounted on a track with a locking control is quite satisfactory.

9. Dash control. This consists of volume control, on-off switch, tuning device,

tivity of the receiver are also better with plate rectification.

The Transmitter

The type of transmitter used depends naturally upon many factors. Roughly, a radio-phone will cover about one-third the distance of a radio-telegraph transmitter of the same power, but will weigh about 20 per cent. more. However, these figures are only relative, since range vs. weight varies considerably with equipment.

The transmitter is governed by the same requirements as the receiver in regard to rugged construction, flexible mounting of parts, accessibility, dimensions, and frequency stability. In the latter case crystal control is a great aid.

A range of at least 100 miles of consistent communication is acceptable for commercial aircraft flying in standard airways, since stations are located every 200 miles, and beacon marker stations with auxiliary equipment every 100 miles. A combined cw and radiophone transmitter seems to be the desirable thing, because few pilots have the time or patience to learn the code sufficiently for expert operation of a straight cw transmitter. As planes become larger and the pay-load question is of less importance than at present, sufficient weight may be allowed for a radiophone of sufficient power to communicate over fairly long distances.

The wind-driven generator is giving way to the more recent type which is direct coupled or geared to one of the plane motors. A voltage regulator keeps the output practically constant. These generators vary in output from 500 watts to 2 kw, and both the filament and plate supply currents are delivered by them. They are available for both a.c. and d.c. output. In some cases the high voltage delivered is 500 cycles or so.

Possibly the power supply of greatest

value lies in a separate small gas engine-driven generator. This could be used for ordinary communication service, and would be invaluable as an auxiliary. Several types have been developed, but a great deal of experimental work is still to be done in this field. A small two-cycle, two-cylinder motor of about 2 H.P. is about right for most commercial purposes.

A battery-driven dynamotor may also

ignition and mechanical noises made the cross-coil beacon necessary. This beacon consists of two coil antennas disposed in two vertical planes fixed at an angle from each other. In a simple form the two-coil system is free to be rotated about a vertical axis. When the two coils are similarly excited with a modulated radio-frequency current, signals of equal intensity will be heard on a receiving set when situated

along either one of the two vertical planes bisecting the angles between the planes of the coils. At other points, the signal intensity from each coil will be different.

A mechanical device can transmit the letter N (— ·) on one loop and the letter A (· —) on the other, and they are so interlocked that a continual buzz is heard along the equisignal zone. A deviation of from 1 to 3 degrees from the course will result in one or the other letter becoming distinctly predominant.

The advantages of this type of beacon are:

1. No zone of maximum or minimum signal strength.
2. Location of course found by the comparison of two signals.
3. A plane may be guided along a given airway without regard to wind drift.
4. When considerably off course, the beacon furnishes a definite signal allowing plane to return to former course. Valuable when plane must make detours or is forced off course.
5. Used on national airways.
6. Ordinary receiver and antenna may be used.

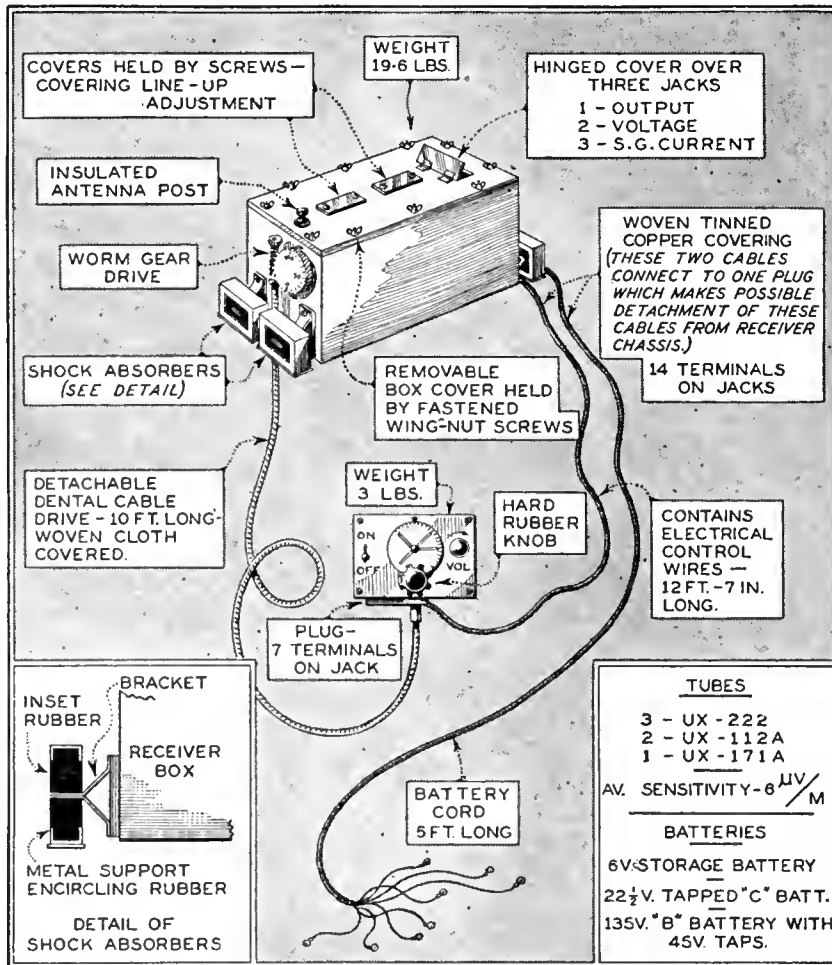

A mechanical description of aircraft beacon receiver type AR1286.

be used to advantage for an auxiliary power supply, and will furnish power as long as the lighting battery lasts.

Frequency Choice

The standard allocated frequency band for radio beacon service is from 285 to 315 kc., and that for aircraft radio communication is from 315 to 350 kc. The design of a receiver to cover this comparatively narrow band of frequencies is comparatively easy and most commercial aircraft receivers are designed for this use.

The 500-kc. band may be used for distress or emergency signals. Frequencies around 3000 to 4000 kc. are good for fairly long-distance low-power communication and are not much affected by fading, skip-distance, directional effects, type of antenna, and other phenomena characteristic of frequencies higher than this. These frequencies will undoubtedly prove of great value in the future of aircraft radio. Frequencies as high as 11,000 kc. have been used with very good success for long-distance, low-power communication on transoceanic flights and expeditionary flights. However, they were naturally affected by skip-distance, etc.

Radio Beacons

The radio beacon of to-day is as practical and perfect as the ordinary magnetic compass. High noise level caused by the

The disadvantages are:

1. "Plane effect" or angle of plane causes slight error.
2. "Night effect" or shifting of equisignal zone at night makes it undesirable for night flying.

(Continued on page 358)

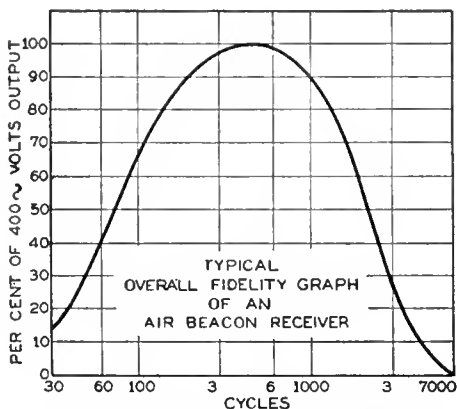

The above curve indicates the overall fidelity of the average air-beacon receiver.

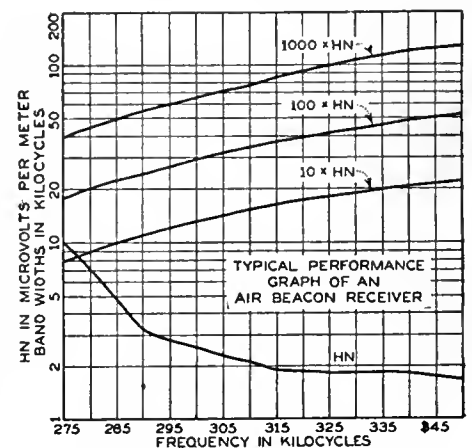

The curve "HN" gives sensitivity in microvolts per meter for 50 mW. output. The other curves give band width in kc. for inputs of 10, 100, and 1000 HN.

STRAYS FROM THE LABORATORY

Sun Spots and Radio

A correspondent questions the correlation between solar activity (sun spots) and radio reception and at the same time wonders if the steadily declining field strengths from distant stations are not due to a "saturation" or overloading of the ether. We sent these doubts and suggestions to Dr. Pickard whose speculations on the interesting questions and long continued measurements on WBBM's field strength have won him great credit. Dr. Pickard's answer is a chapter in the book of fundamental knowledge of radio. Dr. Pickard's curve (Fig. 1) shows such definite relation between solar activity and radio reception as to leave no doubt. Dr. Pickard says:

"Signal strength at night from distant stations has been on the down-grade for at least the past three years. But the correlation of this decrease with solar activity has been proven beyond any doubt, and irrespective of any hypothesis. Many thousands of reception measurements, taken systematically over periods of years, have shown such high correlation with measures of solar activity that the relation of sun and reception is as certain as the relation of moon and tide.

"But 'etheric overloading' is a harder problem. If the entirely hypothetical 'ether' really had the properties of matter, it might, of course, have definite tensile strength, and perhaps also exhibit frictional or hysteretic losses, in which case it would either break up or heat under severe loading. But the majority of modern physicists do not believe there is an 'ether'. Instead, our present-day view is that what we call electromagnetic waves are merely energy quanta shooting bullet-wise across empty space. According to this view overloading has no physical meaning; how can we overload a void by merely projecting more quanta through it?"

"This reasoning may not be convincing to everyone, particularly those who still

cling to their 'ether'. So, avoiding all assumptions as to the existence of properties of the medium, let me present some evidence from the experimental side. First, consider the well-known fact that a station hundreds or thousands of kilometers distant can be well received even

goes through unchanged, save for the slight Einsteinian bending caused by the gravitational field."

British Heater Tubes

An article in January 8, 1930, *Wireless World* entitled "A New Method of Detection," while somewhat misleading in title, since no new method of detection is described, gives some interesting data on English heater-type tubes. American set engineers have long wondered at the high values of mutual conductance secured by foreign tube manufacturers, which cannot all be laid to the fact that tubes "over there" are measured at zero grid bias and not under operating conditions.

The Marconi and Osram MHL4 is called a general-purpose tube, has a plate resistance of 3000 ohms, and an amplification factor of 6. At a grid bias of 23 and a plate potential of 200 volts the plate current is 19.5 milliamperes. It will turn out about 750 milliwatts.

The MHL4 has a resistance of 8000 ohms and a μ of 16. Its resistance is sufficiently low that it may be used with a transformer output with about double the voltage amplification secured from out heater-type general-purpose tube.

Both of these tubes are very good, having mutual conductances of the order of 2000 micromhos (at zero grid bias). The heater consumes 1.0 ampere at 4 volts.

The MHL4 makes a good grid-circuit detector as the curve in Fig. 2 shows. With an r.m.s. input signal of about 2.75 volts it will deliver about 8 volts of a.f. at 50 per cent. modulation. The circuit constants are given on the curve.

A Correction

On page 223 of the February issue curves were given showing the selectivity and sensitivity characteristics of Radiola 21 and 22 receivers. Unfortunately the

(Continued on page 349)

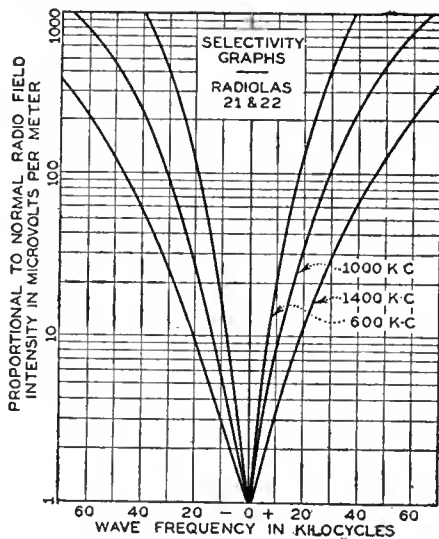

Fig. 3

directly under the antenna of an operating high-powered transmitter. Measurements of the field strength of the distant station show no change when the local transmitter is thrown on and off. Yet, the field immediately around a high-powered transmitter is enormous as compared with that from the distant station, and if there were any such thing as overloading, such a test would show its presence.

"But far more severe tests have been made. A pair of metal terminals may be placed in a tube exhausted to the limit of modern vacuum technique, and a field of the order of a million volts per centimeter can be impressed without breaking down the intervening space. In fact, when such a tube finally does pass current, it is because electrons are bodily torn from the metal terminals; not because the space between is in any way overloaded. Recently very great magnetic fields, of the order of a million or more gauss, have been produced by heavy transient currents in small coils. But the space traversed by this intense magnetic field shows no sign of distress. Such electric and magnetic fields, viewed as strains or loads upon a medium, are millions of millions of times greater than the average loading produced by the radio stations of the world, and still nothing happens.

"Finally, consider the space just beyond the sun's surface, traversed by the intense radiation from the photosphere and by the solar gravitational and magnetic fields as well. Heavily loaded as is this space by both waves and fields, during a solar eclipse we find the light from a distant star

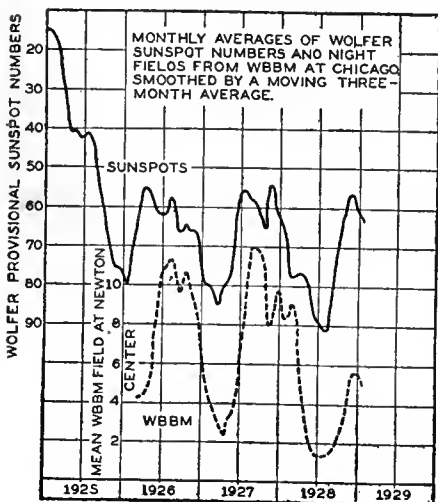

Fig. 1

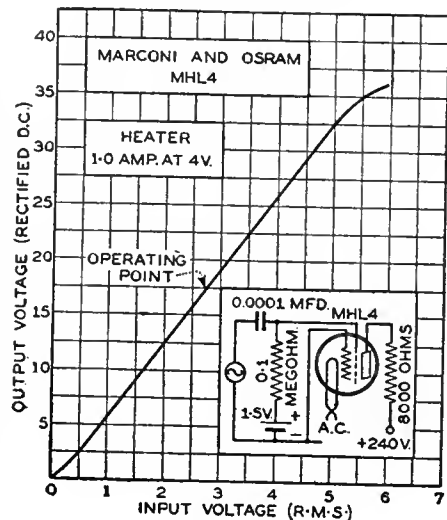
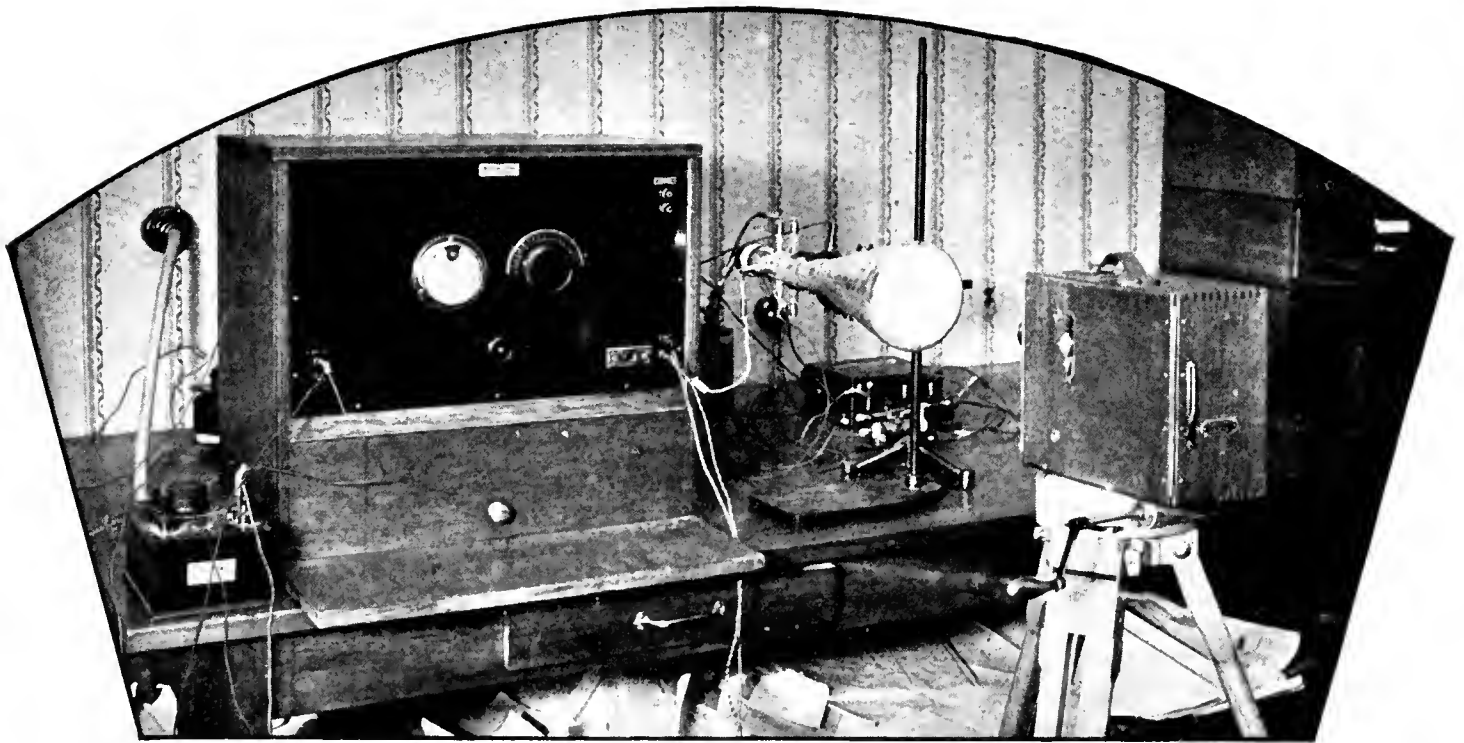

Fig. 2



An untuned amplifier used by the author in his experiments with cathode-ray tubes.

MEASURING PERCENTAGE MODULATION

Using the Cathode-Ray Tube for Determining Percentage Modulation. Desirable Characteristics of a Tube Used for This Purpose. Method of Procedure and Some Typical Examples of the Results Obtained by the Author.

The cathode-ray tube has always been a most useful device in laboratory measurements on all kinds of pulsating or alternating currents. Additional uses for the tube are always being found and in this article Mr. von Ardenne (who has contributed several articles published in the Proceedings of the Institute of Radio Engineers) describes a method of using the cathode-ray tube in the measurement of percentage modulation.

THE DETERMINATION of the percentage of modulation with the Braun tube may be made by two procedures: (1) the method of standing figures and (2) the direct taking of the modulation-time curve.

The procedures included in the first group are the older and have been described numerous times in the last few years. A superficial explanation of the general method for the production of standing figures is as follows: the high-frequency to be demodulated is fed to a rectifier and the low frequency so obtained is coupled to one of the sets of plates of the Braun tube, while the high frequency is coupled to act on the cathode ray at right angles to the low frequency. If an oscillograph is made of a high-frequency transmitter in this way, with the modulating current having a constant frequency and amplitude, and if the high-frequency axis is made the horizontal one, then a figure is to be expected which has for its maximum and minimum widths the corresponding limiting values of the modulated high frequency. If the demodulated low frequency of the transmitter is put on the vertical plates of the tube without time lag, then a stationary trapezoid is obtained on the fluorescent screen. The parallel sides, a and b , lie horizontal and the percentage modulation

By **BARON MANFRED VON ARDENNE**

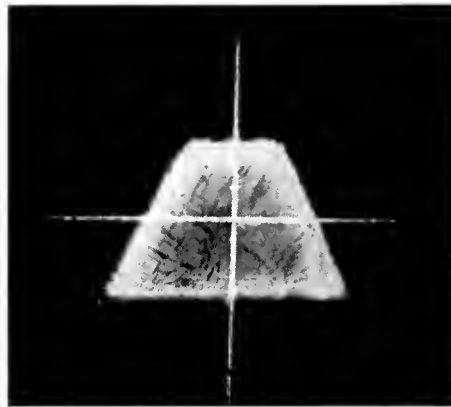

Fig. 1—The photographic result of experiments with standing figures.

of the transmitter can be computed immediately from the expression—

$$K = \frac{a-b}{a+b}$$

The advantage of the method lies in the possibility that tubes with very weak fluorescent spots can be used successfully when the photographic exposure is made long enough. On the other hand, a long photographic exposure is necessary, and in this fact lies a limitation of the use of the trapezoid method, if the transmitter is excited only with a constant amplitude of low-frequency power. If the amount of modulation varies, then the height of the trapezoid also changes so that a measure-

ment of the parallel sides is no longer possible. If a broadcast transmitter is used, in which not only the amount but also the frequency of the modulation varies then the whole trapezoid changes. This will be true particularly at higher frequencies, since phase displacements take place in the coupling elements of the rectifier and amplifier which completely change the boundaries of the trapezoid. Furthermore, the trapezoidal form is only obtained with very small high-frequency amplitudes, since with larger amplitudes at the input of the rectifier, the corners are rounded off.

The Second Method

The second method is free from these disadvantages. It consists in producing a time axis by means of a rotating mirror or a moving film. Naturally this method can be used for any sort of modulation curve, including those of broadcast transmitters, and at the same time it will allow observation of peak values of excitation. How important such a control is in order to maintain a small amount of distortion in the detector of the receiving set is generally understood. Since the envelope of the modulated high frequency is visible on the film or in the rotating mirror, the sinusoidal form can be seen beautifully when the excitation is from a low-frequency oscillator and the complex shape when it is due to speech.

For photographing the modulation curve, it is very important to have a tube which gives a very bright fluorescent spot. The brilliancy of this spot determines the highest speed at which the film can be moved, and therefore the highest modulation frequency which can be recognized on the film. For direct observation of the modulation on a rotating mirror a bright spot of light is also very desirable, since this permits observations in daylight. In

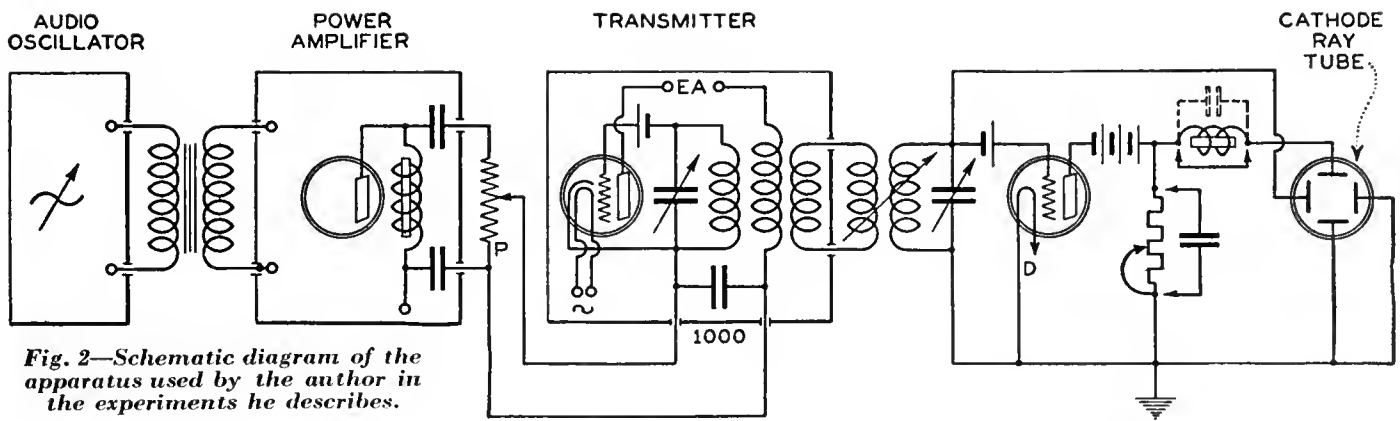

Fig. 2—Schematic diagram of the apparatus used by the author in the experiments he describes.

the following paragraphs a cathode-ray tube is described which was developed in the author's laboratory and which is particularly suited to measurements of this type due to the markedly greater brightness of the spot.

The Apparatus Used

In making the experimental modulation pictures shown on these pages the most important piece of apparatus was, of course, the Braun tube. This tube, which is shown in Fig. 3, has a fluorescent plate made of a material which fluoresces in blue-violet, and therefore is very active photographically. The picture, Fig. 3, was taken in the dark and shows clearly the path of the cathode ray in the tube. To the right the ray, coming from a concentric cylinder, passes through two systems of condenser plates placed at right angles to each other. The top of the tube is illuminated due to the impact ionization of the small amount of rare gas present. The beam produces on the fluorescent screen an extremely strong point about 0.75 mm in diameter.

In operating the tube it is important to keep the leads to the condenser plates short and the condenser plates themselves must be small. By separating the leads a sufficiently small capacity can be obtained to hold up the impedance so the device will have no frequency characteristic, even at high frequencies.

The heading picture shows the untuned amplifier used with the cathode-ray tube. To the left is a tuned circuit in front of a multi-stage, high-frequency amplifier whose gain is accurately known and can be increased to a voltage amplification of 50,000. After the amplifier, which con-

tains six resistance-coupled stages, is a second tuned circuit which, in turn, is connected to the horizontal plates of the Braun tube. The sensitivity of this arrangement is so great that a strip of light 3 to 4 cm wide can be obtained from a broadcasting station 1000 to 2000 km (600 to 1200 miles) away. The circuit, therefore, can be used to observe the modulation of distant stations.

The arrangement in use at present is shown in the schematic of Fig. 2. It consists of a powerful transmitter using plate modulation which can be excited by an oscillator and power amplifier. The percentage modulation can be adjusted by means of the potentiometer P and can be marked conveniently on the dial from zero to a complete overload. The rectifier shown after the modulator was only used in investigations of the method of standing figures. For the method used in taking photographs of Fig. 4 the rectifier D was omitted.

The determination of the percentage modulation has been made by both meth-

ods. As a source of modulated high-frequency power both the modulated oscillator of the laboratory and local and long-distance broadcasting stations were used. The result of the tests of standing figures is given in Fig. 1, and in making this particular picture the local oscillator was used to supply power. A trapezoid with straight lines for its sides was obtained. In order to obtain this figure two stages of resistance-coupled amplification were used after the rectifier D. In this way it was possible to make the input voltage of the rectifier extremely small by a loose coupling with the oscillator, and thereby reduce the curvature of the rectifier characteristic to such an extent that the rounding of the corners of the trapezoid would not be noticed. The percentage modulation from the two sloping sides where $a = 35$ mm and $b = 14$ mm is

$$\left(\frac{a-b}{a+b} \right) \text{ or } 43 \text{ per cent.}$$

It is obvious that the trapezoid method can also be used for broadcasting stations.

However, it is only in the case of picture transmission stations, where the transmitter is modulated with a constant frequency, that the results are particularly good.

The method providing a visible indication of modulation was used for both the modulator and the broadcasting stations. The plate voltage employed was 1500 and this gave sufficient brilliancy to enable making photographs with normal film and a 1:1.5 opening. Fig. 4 (A, B, and C), show the curve of modulation against time for different degrees of modulation, obtained with the potentiometer P in Fig. 2. The demodulated low frequency was 800
(Continued on page 360)

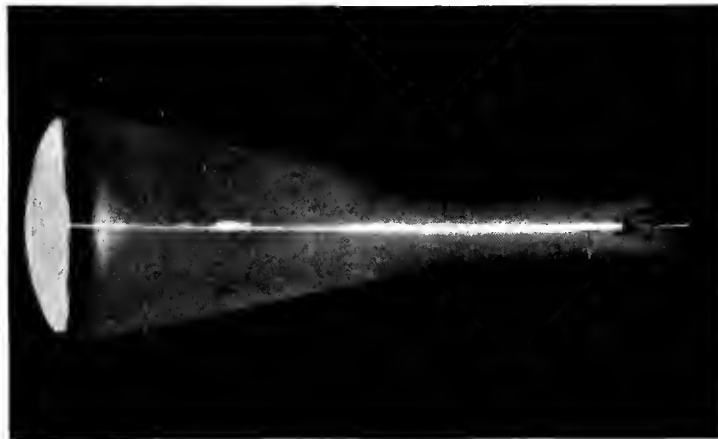

Fig. 3—The Braun cathode-ray tube photographed in a dark room.

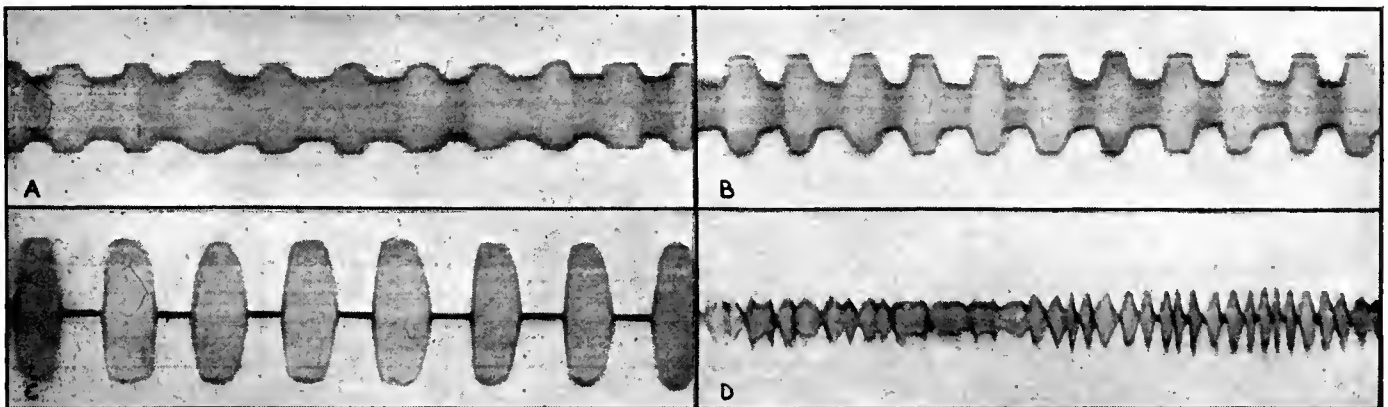

Fig. 4—Oscillograph curves taken on signals of various degrees of modulation.

AUTOMATIC VOLUME CONTROL

A General Description of How Automatic Volume Control Circuits Function. Some Details of Experiments on Circuits by the Author.

By A. C. MATTHEWS, JR.

A VOLUME CONTROL on a radio receiving set has three distinct functions to perform, that is to compensate difference in volume of stations at various distances; to compensate any variations in signal strength due to slow fading, and to adjust the volume level to the desired intensity. An automatic volume control accomplishes the first two objectives inherently, while the last function is left to the particular likes of the operator. The setting of the volume level, however, is made only once and thereafter all stations within the range of the receiver are reproduced with the same degree of intensity, assuming, of course, that their percentage of modulation is nearly the same.

Several types of automatic volume controls have been proposed in the past and the following are referred to as examples of the various types.

1. Plate current of the output tube in series with a UX-199 filament arranged so as to vary the bias on a preceding tube, thus preventing overload and limiting the volume. (*Proc. I.R.E. March, 1928, p. 281.*)

2. Varying the plate voltage on the radio-frequency amplifier by means of a control shunting the loud speaker. (*RADIO BROADCAST, March, 1929.*)

3. Adjusting the radio-frequency amplifier bias by means of a two-element rectifier tube. (*Proc. I.R.E. January, 1928, p. 30.*)

4. Varying the bias on the radio-frequency amplifier by means of a three-element tube connected in a simple rectifier circuit. (*Proc. I.R.E. March, 1929, p. 511.*) Of the four systems referred to, the author prefers the last mentioned method, since it has several advantages over the other types.

Experience has taught us that in order to provide automatic volume control without introducing distortion the device must operate on the carrier wave. Any variation in the carrier wave strength must be compensated by an inverse variation in radio-frequency amplification. The type of automatic volume control described in this article meets this requirement and is exclusively for use with the a.c. screen-grid tube (UY-224). Since it is permissible in screen-grid receivers for the volume control to vary the screen-grid potential,

it was thought advisable to devise some scheme whereby this method might be accomplished automatically so as to compensate any change in signal strength, thus giving us an automatic volume control.

As may be seen in the accompanying diagram, the carrier signal is applied to a rectifying circuit and the rectified a.c. component is impressed back on the preceding amplifier screen grids, thus

This article by Mr. Matthews, formerly a radio engineer with the Steuart-Warner Corporation, describes some experiments on automatic volume control circuits for use with screen-grid tubes. The control system which is described operates automatically and varies the amplification of the r.f. amplifier tubes by varying the voltage applied to the screen grids of the screen-grid tubes.

—THE EDITORS.

regulating their amplification inversely with the original signal. In other words, when a signal on the regular detector exceeds a certain predetermined value the bias on the volume-control tube is reduced and its plate current increases. This increase in plate current is used to obtain a voltage drop across a 25,000-ohm resistor, thus decreasing the screen-grid potential on the r.f. tubes and thereby reducing the overall amplification. Since the amplification curve of the screen-grid tube slopes rather rapidly as the screen-grid potential is increased, this makes a very effective volume control.

The circuit constants of the volume-control tube have been arranged so as to adjust the time constant of the circuit correctly in order that no appreciable time lag will occur when the carrier wave suddenly varies in intensity. However, the time constant is not high enough to prevent correct operation on low modulated frequencies.

Since the volume-control tube must have its plate at the same potential as the screen-grids of the r.f. amplifier, it is necessary, in order to obtain the correct plate voltage on the UY-227 volume-control tube, to take off voltage taps at -60 and -80 volts on the power-supply unit. This puts a potential of approximately 135 volts on the plate with respect to the cathode.

The volume level may be set at any predetermined value by adjusting the bias on the volume-control tube. Fig. 2 shows curves taken with and without the automatic volume control. A, B, and C show the peak voltages on the first a. f. grid at three different volume-control settings. With the volume control in the position for maximum signal the sensitivity of the set is not impaired in the least, in fact the only indications that an automatic volume control is being used are due to the absence of fluctuating signals and the usual blasting encountered when tuning through a local carrier wave. Also when the sensi-

tivity of the set is being taxed a noticeable fluctuation in the background noise will be very much in evidence as the sensitivity is varied in order to compensate the decrease in signal strength. This one disadvantage, however, is more than offset by the many desirable features of this type of volume control and in the opinion of the author it is negligible. Curve D shows the peak voltage on the first a.f. grid with the automatic volume control disconnected. The sudden change in curve D is due to detector overload.

When the volume is once adjusted all stations within the receiving range of the set are reproduced with the same volume providing the modulation of all the stations received are nearly alike. This is very convenient when tuning through the carrier of a local station since very bad blasting will occur unless some sort of limiting device is utilized. When using this type of volume control the plate current of the r.f. amplifier is at a minimum when the receiver is tuned exactly to resonance and since the volume does not fluctuate it is difficult to tune the receiver unless a plate milliammeter is used as a resonance indicator.

Recent Changes

Since doing the laboratory work described in the preceding test certain slight modifications in the circuit constants have been found desirable. Although these changes do improve the practical operation of the circuit, they do not alter the operating characteristics of the system, so the curves of Fig. 2 still apply.

The first change found necessary was reducing the capacity of the coupling condenser from 250 micromicrofarads, as indicated in Fig. 1, to 100 micromicrofarads. The smaller capacity helps to prevent any grid rectification from occurring when receiving strong signals.

Also it is general practice now to operate the screen-grid tubes at a screen potential of 75 volts instead of 67 volts as originally specified by the tube manufacturers. The higher operating potential requires the use of a somewhat larger plate resistor for the volume-control tube, but, as stated previously, this does not alter the essential operating characteristic of the control circuit.

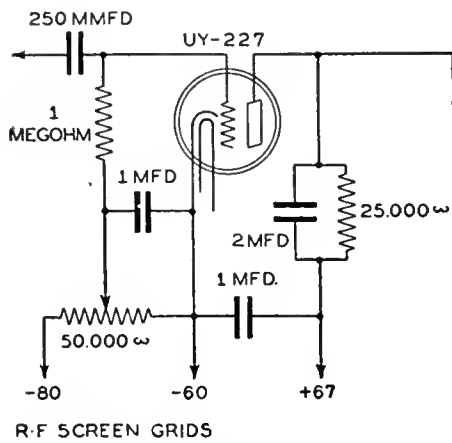

Fig. 1

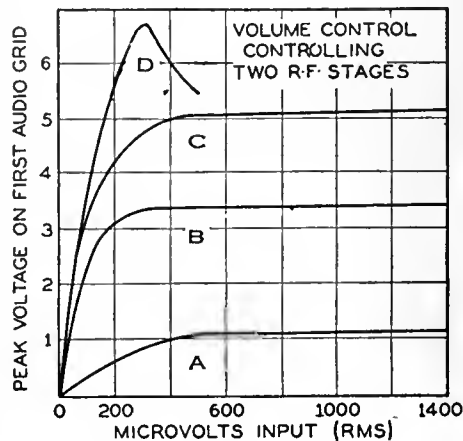

Fig. 2

FACTORS GOVERNING AMPLIFICATION

THE VACUUM TUBE is unique among modern machines in that it amplifies power, differing in this respect from a transformer which amplifies voltage at the expense of current or *vice versa*. Strictly speaking this is not true, i.e., the tube and associated apparatus, considered as a whole, does not amplify power. For example, if you calculate the total power going into a tube, say a 245-type power tube, and calculate the total useful power coming out you will see that there is an overall loss of power. But if you neglect the filament power and the waste of power in heating the plate and consider only the input power fed to the tube as compared to the useful output power, you will see there is amplification.

What actually takes place in the amplifier is something like the following; a small amount of power is utilized to operate the tube acting as a valve which releases a large amount of power from a local battery.

Example: In Fig. 1 consider a power tube getting its input voltage from a.c. flowing through a resistor, and feeding power into a load resistance. The input voltage is the product of the current and the resistance. The output power is the product of the current squared through the load and the load resistance. Thus,

$$\begin{aligned} \text{Input voltage} & E_i = I R_i = E_g \text{ r.m.s.} \\ \text{Input power} & P_i = I^2 R_i \\ \text{Output power} & P_o = I_o^2 R_o \\ \text{Output current} & I_o = \mu E_g / (R_o + R_p) = \mu E_g / 2 R_p \text{ if } R_p = R_o \\ \text{Output power} & \frac{\mu^2 E_g^2}{4 R_p} \\ \frac{\text{Output power}}{\text{Input power}} & = \frac{\mu^2 I^2 R_i^2}{4 R_p I^2 R_i} = \frac{\mu^2 R_i}{4 R_p} \end{aligned}$$

Putting the proper values for a 245-type power tube into this equation, the power gain, i.e., the ratio between power output and power input, is about 15 times.

Coupling Devices

The tube, no matter how much amplification it may produce standing by itself, is useful only when connected with associated apparatus. We put a voltage into the tube and extract some power out. This voltage must be put in by means of accessory apparatus; the power output must be delivered to some load apparatus.

The usual means of coupling one tube to another are well known to every experimenter, viz., resistance, inductance, or transformer, but it is not every experimenter (or engineer either) who, without a great deal of hemming and hawing, can tell you how many stages are necessary to deliver a certain amount of power into a given load when the input is known, or how much is the overall gain of a two-stage, transformer-coupled amplifier, or whether it is better to put a transformer stage ahead of a resistance stage when combinations are used.

In resistance-coupled amplifiers, about 75 per cent. of the amplification factor of the tube can be

realized. The amplification factor is a term which indicates the output voltage which would exist across an infinite resistance load if one volt were impressed on the tube. Unfortunately an infinite resistance load is unattainable and some of the total voltage available in the plate circuit of the tube is used up in heating the plate of the tube and is not employed usefully. Therefore, not all of the voltage amplification of the tube can be used. If the load resistance is

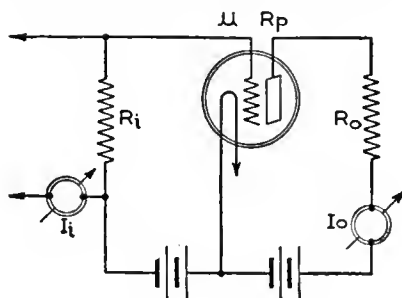

Fig. 1

three times the tube resistance, three times as much voltage will appear across the load as across the tube (we are speaking of a.c. voltages), and therefore the voltage amplification will be $\mu \times 75$ per cent.

In a transformer-coupled circuit, the primary inductance into which the tube works is very high and, because of the fact that the total impedance in the plate circuit must be obtained by taking the *vector sum* (see "Home Study Sheet" No. 10, Nov. 1928), the actual voltage amplification obtained will be about 89 per cent. of the μ of the tube if the reactance into which the tube works is twice the tube resistance in ohms. This will be true at the frequency at which the reactance of the transformer is twice the tube resistance, and, since the maximum obtainable is only 100 per cent., the variation in amplification can be only between 89 per cent. and 100 per cent. At all frequencies higher than that at which the transformer reactance is twice the tube resistance, the amplification will be greater than 89 per cent. of μ and will approach 100 per cent. as a maximum.

A Typical Problem

Suppose then you have a detector capable of putting out one volt, and that you need to have 50 volts on the input of a power tube to deliver the required amount of power. How many stages of a.f. amplification, each using

a three-to-one ratio transformer and a tube with a μ of 8, are necessary? What C biases will be necessary? The circuit is in Fig. 2. It is only necessary to calculate the voltage input to the first a.f. stage by multiplying the voltage across the a.f. transformer primary by the turns ratio, then, by multiplying this voltage by 90 per cent. of the μ of the tube, you get the a.c. voltage across the primary of the next transformer and so on until the voltage available for the power tube grid is ascertained.

Now suppose you want to use two resistance stages and one transformer stage—if, for example, two transformer stages give not quite enough amplification. Should the transformer or the resistance stages come first or should the arrangement be first a resistance stage, then a transformer stage, and finally a resistance stage? The way to solve this problem is to make diagrams of the three possible cases, figure the voltages that will appear on the grid of each tube, and therefrom find what the C bias on these tubes must be.

If the transformer stage comes first, the voltage on the grids of the following tubes will be rather high, which will require high values of C bias, and because of this high bias a high plate voltage will be needed. Since these tubes are fed through plate resistors in which there is a drop in voltage of one volt per thousand ohms for each milliampere plate current, a large plate battery will be required. For example, suppose the voltage on the grid of a resistance-coupled stage calls for a C bias of 3 volts. If the tube has a high- μ this will call for a plate potential of probably 180 volts (so there will be a sufficiently long straight portion of the characteristic to handle the 3-volt input), and if the tube takes 0.5 mA. at this voltage working through 200,000 ohms, a plate battery potential of 280 volts will be necessary.

On the other hand, if the input voltage to this tube is quite small, for example, when worked directly from the detector, a small C bias will be necessary, a shorter portion of the characteristic need be straight for distortionless amplification, and hence lower plate battery voltages are required.

Thus if a combination amplifier is to be constructed it is better to place the resistance stages before the transformer stage.

Overall Amplification

Very few radio workers have much conception of the total amplification attained in modern radio receivers. They do not know how this voltage gain is distributed. They do know that the advent of the screen-grid tube has shifted the proportion of amplification that exists before and after the detector. But how much? This is answered in "Engineering Sheet" No. 34. This sheet also considers the amplification which may be obtained in circuits using present types of pentodes.

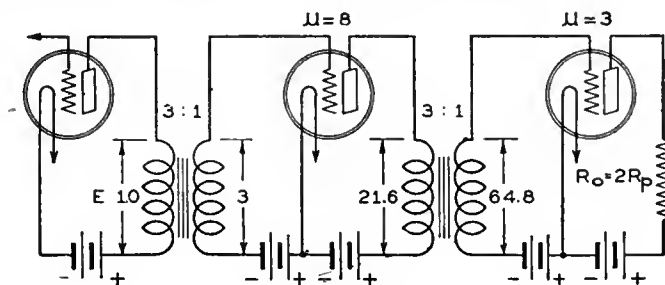

Fig. 2

CALCULATING AMPLIFICATION OF PENTODE RECEIVERS

THE ADVENT OF TWO new tubes, the screen-grid pentode and the power pentode, is sufficient cause to sit down and calculate the present gain of receivers, and what will happen if set designers choose to use these new tubes.

The new screen-grid tube is roughly 1.25 times as good as present-day screen-grid tubes. That is, it will deliver about 1.25 times as much amplification. The power pentode is about 5 times as sensitive as a 245-type tube. That is, to deliver 2000 milliwatts it requires only 12 volts input whereas the 245-type tube requires 50 volts to deliver about the same power output, 1600 milliwatts.

Suppose a receiver, Fig. 1, has push-pull 245-type tubes working directly from a detector through a transformer with a turns ratio of 5 to 1. Across the secondary of the input push-pull transformer is required 100 volts if the power amplifier is to be "loaded up." Therefore, a potential of $100 \div 5$ or 20 volts is needed across the primary. This is the a.f. voltage the detector must deliver. This calls for a power detector, i.e., a highly biased detector probably of the 227 type. At 22 per cent. modulation and working into 200,000 ohms, such a tube will deliver one volt a.f. for each volt r.f. put on its grid. If the modulation reaches 100 per cent., as it may from many modern stations, the output will be roughly 5 times the r.f. input voltage. This is the maximum voltage that will never be reached and should be just enough to put 100 volts across the two push-pull

transformer. How many stages are necessary? Three stages will give a total of 27,000, more than is necessary. Therefore, somewhat looser coupling to the antenna can be used with increased selectivity and greater freedom from unwanted noise, or a smaller antenna can be used (the ice pick, for example, as one manufacturer—Silver-Marshall—advertises.)

Think back to receivers of a few years ago which had a resistance-coupled buffer stage between antenna and the set, in which there was a

input must be $12 \div 40$ or 0.3. In other words, substituting a screen-grid detector in place of a low- μ tube and transformer causes a gain in sensitivity in the ratio of 2 to 1 (6 dB).

In addition to this gain in sensitivity there is a possible saving in money due to the substitution of a condenser-resistance coupling unit in place of a transformer. In Fig. 2 is the complete screen-grid-detector, pentode-output-tube receiver. We now need a gain of only 750 in the r.f. amplifier in place of 10,000. If each tube gives a gain of

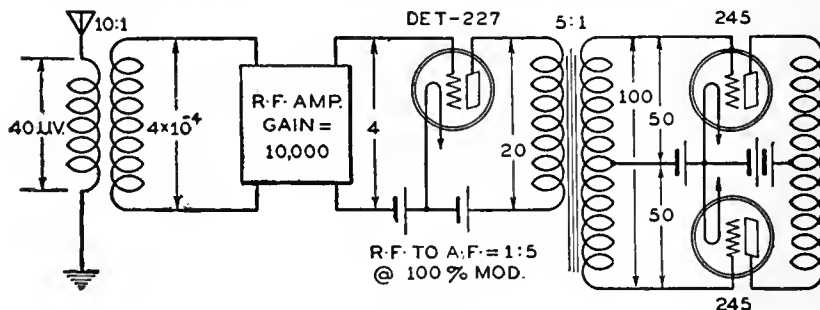

Fig. 1

voltage gain of perhaps 3, plus two r.f. stages using 201A-type tubes. What was the total amplification up to the detector? About 500 at a maximum—unless there was considerable regenerative amplification. This meant that a grid leak and condenser detector, which is about 10 times as sensitive as a C-bias detector, was necessary. Then

30, two stages will be somewhat more than enough and we have a receiver with two r.f. stages using screen-grid tubes, a screen-grid detector, and a pentode power tube—four tubes in place of present-day sets using five or more (usually more) tubes.

Such a receiver represents no great advantage over present sets. The reduction in the number of tubes needed may make necessary greater filtering to reduce the a.c. hum in the output; and because fewer parts are required does not mean that these parts may not have to be better, thus keeping the total cost at approximately the same figure.

If the screen-grid tube of the future is better than present tubes of this type, still fewer stages may be possible, but it does not seem likely that a single r.f. tube will ever take the place of two stages as it is too difficult to pack into one tube and its circuit all the gain required. The problem of calculating the voltage gain in a receiver or amplifier has been illustrated by this "Engineering Review Sheet"—and that was the object in view.

Problems

1. Four milliamperes of current at 1000 cycles are fed through a 10,000-ohm input resistor. The voltage across this resistance is applied to a 245-type power tube whose amplification factor is 3.8 and whose plate resistance is 2000 ohms. Calculate the input and output power and the power amplification.

2. The power obtained from a tube is a maximum when the output resistance is equal to the tube resistance, as in Problem 1, but the maximum *undistorted* power is secured when the load has twice the tube resistance. Calculate the power into a 4000-ohm load and notice how little power is lost in not exactly "matching" the tube and load.

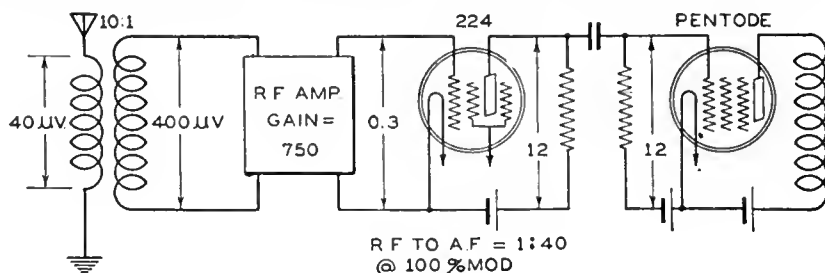

Fig. 2

tubes. Thus, if the input to the detector is 100 per cent. modulated, the r.f. voltage to deliver 20 volts a.f. need be only 4 volts.

A Practical Case

We need, therefore, an input r.f. potential to the detector of 4 volts. Now suppose we are situated in the field of a transmitter such that across the antenna appear 40 microvolts. How much amplification must there be between the input to the set and the input to the detector? Obviously the amplification is 4 volts divided by 40 microvolts or a total voltage amplification of 100,000. Now between the antenna and the input to the first r.f. tube there is usually a gain of 10, so between the first r.f. grid and the detector grid there must be a voltage gain of 10,000.

Suppose it is possible to obtain a voltage gain of 30 per stage from a screen-grid tube and its accompanying

came two stages of transformer-coupled a.f. amplification with an overall gain of about 72. What was the total voltage amplification?

Now suppose you use a pentode power tube requiring only 12 volts to deliver 2000 milliwatts. If worked from a detector with a four-to-one transformer the detector output need be only 3.0 volts, and at 100 per cent. modulation the r.f. input to this detector need be only 0.6 volt instead of 4 volts; thus we can get along with one-seventh ($1/6.7$) as much amplification in the r.f. amplifier.

Suppose you want to use a screen-grid detector which has a conversion factor of about 40 to 1, i.e., a 100 per cent. modulated r.f. signal of one volt will deliver 40 volts a.f. It must be coupled to the power tube through a resistance (because of the tube's high resistance) and so the gain in the transformer will not be secured. We need 12 volts output and so the r.f.

PROFESSIONALLY



SPEAKING

1930 AND SERVICE

IF, AS THE general service manager of a large and well-known radio manufacturer believes, the 1930 service problem will be one of negligible importance, the entire industry will have put behind it a most serious problem. The question of whether a manufacturer should send service literature to the "independent" serviceman or whether he must compel all servicing to be handled by servicemen attached to authorized dealers has been solved by the majority of manufacturers to their own satisfaction. The "independent" has no place in this picture. The reasons as cited by the service manager quoted above are:

1. He (the "independent") does not fit into the manufacturer's scheme of positive control over field service organizations.

2. The manufacturer has no claim upon his loyalty.

3. He is under no obligation to execute the manufacturer's policy with respect to guarantee, etc.

4. There is nothing to prevent the discontinuance of his activities in any locality thereby leaving that place without adequate service facilities.

5. The manufacturer cannot logically support his own field service organization on the one hand, and encourage the independent service organization as a group on the other hand.

Granting all these points, and granting the fact that we are not on the firing line of service but are in a comfortable office far from the front, we believe there is but one attribute of service that needs consideration—is the service adequate? This means, does the remedy cure the ill, is the cost commensurate with the effect secured, and does the service require only a reasonable amount of time?

We believe that being connected with a dealer is no assurance that a serviceman is a good one. On the other hand, we believe such a serviceman is probably not as good as his brother who gets out and hustles for himself. As soon as a serviceman learns his calling and becomes an efficient and effective unit, he discovers that the meager salary the dealer can afford to pay is less than he can make on his own. Therefore, he gets out of the dealer's shop and goes after business for himself.

One trouble seems to be that a dealer cannot afford to hire a good man. The serviceman can make more money on his own; therefore, he becomes an "independent."

Perhaps some scheme like the following would work out. We have already suggested that the manufacturer pick all servicemen by a technical examination. This would obviate the difficulty that the dealer, not being a technical man himself, has trouble in knowing a good serviceman when he sees one. After the prospective serviceman has passed the examination, let the dealer take him on and, except for a percentage of the income to pay for the service share of the rent and for the use of

the dealer's instruments, let the serviceman take all the profits.

The examination will prove that he is a good technician; the fact that all the money goes to the serviceman makes it possible for him to work as hard as he likes with the certainty that the money will be his.

The tendency for large dealers to farm out their service is a step toward the latter scheme. It is a fact that no dealer can afford to pay a serviceman enough money to make it worth the while of the latter to stay out of the "independent" rôle. The farming out process can take place only in

Attention—

Why the industry does not recognize the independent radio serviceman.

A solution to the combined problems of radio dealers and servicemen.

How will the pentode tube improve radio receiver design?

large communities, and, although a large percentage of all sales is made by a small number of dealers, these sales take place where there is plenty of service available. It is the customer in small districts who needs service the most and who has the least chance of getting it.

But let us hope that the 1930 service problem will be one of negligible importance. If 1930, however, is marked by another race to see who can make the most receivers at the lowest price, we believe there will still be a service problem of considerable importance.

NEW TUBES

A new tube which had been spoken of quite calmly in Europe finally broke into the public press in January, thereby disturbing the entire radio industry to a considerable degree. This tube is the pentode, a five-element tube. In Europe it had taken the form of a power-output tube of superior sensitivity and efficiency. In this country there are two such tubes, the power-output tube and a screen-grid tube with an additional grid.

The pentode power tube came into the limelight slowly and was demonstrated before a well-attended meeting of the Radio Club of America. Knowing the propensity of the newspapers to exaggerate the importance of any technical development, the authors of the paper "hedged" and said the new tube would not make any startling difference in radio receiver design.

The other pentode was announced by a tube manufacturer with the statement that it would make possible a \$50 receiver by cutting out sufficient tubes from the present type of sets. It was described as twice as good as present-day tubes. The newspaper writers took up the matter with great glee and soon the trade associations thought

something ought to be done about this pentode business before the public began to look for the new set and to refuse the old.

The statement of the trade association was made with very little regard for the cold hard facts with which the engineering profession deals and which, we believe, ought to be interpreted to the buying public. The statement denied practically everything that had been said in favor of the new tubes.

Aside from whether or not the various statements were ill advised and devoid of facts, the situation is indeed unique. So far as we know, for the first time in the history of the industry a tube manufacturer developed a tube in his own laboratory and instead of hiding his light under a bushel until he could get tooled up or had sold the rights or whatever it is you do to corner the other fellow's market, he distributed characteristics of the tube to engineers and asked their suggestions.

Set engineers have asked such co-operation before. They have wanted tube designers to present their characteristics, and ask for the suggestions of circuit engineers so that the final tube design could be worked out with the circuit people in mind. While it is quite probable that not a dozen circuit engineers in the country have any ahead-of-the-minute ideas about what to do with a new tube when one is presented for criticism, it is a good idea anyhow. Let the tube people make a tube, and ask the circuit people how to make it better for their needs. Conversely, let the circuit people lay down a diagram and beg for a new tube to fit into it.

Let us look at this pentode business seriously. There are two kinds, the power tube and the amplifier. The pentode power tube delivers about the same output as a 245-type tube but is roughly 15 db more sensitive. Calculations on page 338 of this issue show that such a tube with a screen-grid detector ought to make it possible to get along with only four tubes plus a rectifier and make a set just as good as present-day sets with more tubes. But you still need two stages of r.f. amplification, and therefore, even if a new screen-grid tube which was twice as good as present tubes made its appearance, it would not be good enough (because the overall gain of two stages is the product and not the sum of the individual stages). In other words, the pentode voltage amplifier is not good enough to act with a power pentode to make a three-tube set practicable. It is better, but not enough.

The pentode power tube will undoubtedly fit into the picture of many manufacturers. There is no reason for everyone to rush into the design and production of a pentode set, because the public won't be able to tell the difference, except perhaps in price. It makes a four-tube set possible but not a three-tube set. As for the screen-grid pentode, it must be proved that it really is worth the bother of adding terminals to the base and to the socket and other circuit changes.

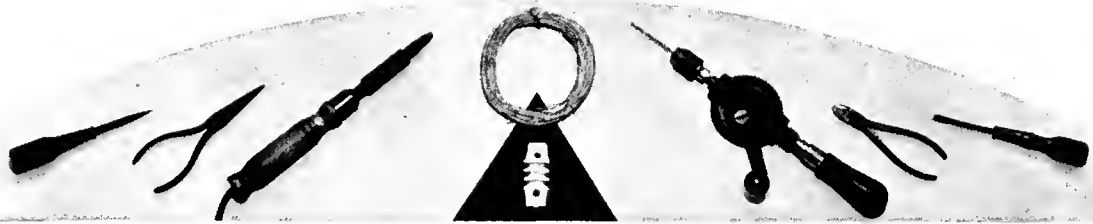

THE SERVICEMAN'S CORNER

Technique of Servicing

BORIS S. NAIMARK, one of our regular New York City correspondents, sends us the following notes on a neglected subject.

"Did it ever happen to you—you being a good and conscientious worker—that just as you were putting the finishing touches on an ailing receiver you let your screw driver slip and left a glaring scratch in the most conspicuous part of a beautiful and highly prized cabinet?"

"Anticipating the possibility of such occurrences in every day service work, I obtained, through an authorized Philco dealer, a cabinet touch-up kit known as Philco Part Number 3809, and containing all the materials necessary for minor cabinet repairs. I have found that this work is not at all difficult and can be handled by any serviceman after very little practice.

"The Philco kit enables one to touch up scratches and white edges on cabinets, and consists of the following materials:

Burning-in Wax: Dark Red, Brown, and Red.

Powdered Stain: Bismarck Brown, Van-dyke Brown, Burnt Umber, and Malachite Green.

Also: Liquid White Shellac, Alcohol Lamp, Wood Alcohol, Felt Block, Felt Pad, Rubbing Oil, Steel Wool, and Knife.

"To touch up light finishes take a small amount of the stain nearest the cabinet color and dissolve in a quantity of white shellac. A little of the green stain added to the darker colors will make them lighter. Having obtained the right color, apply it with a pencil brush to whatever parts need touching up. Let this dry and then apply a coat of white shellac. If this has too high a gloss rub lightly with the felt block and rubbing oil.

"To burn-in scratches and bruises, heat the knife over the alcohol flame. When the knife is sufficiently warm apply wax of the proper color to the scratch and smooth it down with the knife. This is then rubbed with the felt block and rubbing oil. If too high a gloss is thus obtained it can be dulled easily by rubbing lightly with steel wool."

WATCH THE SOLDERING IRON

"In using an electric iron on a set which is hooked up it is a wise precaution to remove all of the tubes or better still to disconnect the receiver from ground and 110-volt supply. One wire of your

Optimistic declarations on the part of some writers to the contrary, the lot of the serviceman is not altogether a happy and prosperous one. The salary of a serviceman in the employ of a dealer is rarely commensurate with his ability and skill. The independent serviceman, working on his own hook, and perhaps under contract or verbal agreement with several dealers, is much better off, but it is not the easiest thing in the world to so establish himself. The serviceman is invited to read "An SOS To The Established Serviceman" in this department and to write us concerning the most advantageous solutions of his several problems.

—The Editor.

house current is grounded; also one side of the radio set runs to this common ground. It cost me two power tubes to find out that a brand new electric soldering iron can have a short in the case. I was put-

ting a series of by-pass condensers across a B battery and had the switch turned off in the set; nevertheless I got a short from the iron which allowed the 110-volt a.c. to run through the filament circuit on the a.f. side and two new tubes 'went west.'"

J. B. TEMPLE, Toronto, Ont.

Mounting Loud Speakers

A moving-coil loud speaker can be mounted advantageously in the upper corner of a room as suggested photographically on this page. An installation of this kind will appeal even to the discriminating customer, and is acoustically very fine. It is essential, however, that the louvres be cut in the baffleboard, or the effect will be drummy. Also mount the loud speaker from one quarter to one half inch behind the opening for the best reproduction.

The idea of compensating tone discrepancies by moving the cone nearer to or farther from the opening in the baffleboard is also suggested by H. D. Hatch, of Wollaston, Mass., who writes:

"A customer recently complained that her Magnavox electrodynamic loud speaker gave a hollow sound on voices. After assuring myself it was not due to the set I loosened the loud speaker and moved it back from the opening in the baffle. The idea was to reduce the baffle effect on the longer waves or low notes. Turning the set on I moved the loud speaker back and forward until the customer was satisfied."

A Hum Filter

An arrangement for the reduction of hum in special cases, which, by the way, should be effective in reducing certain forms of artificial static, is suggested by an engineer now with the Bureau of Standards.

"Certain radio receivers, under the proper (or rather improper) conditions, will hum rather badly when a station is being received, even though the hum level may be very low when no signal is tuned in. This phenomenon has been noticed in a number of receivers, both factory- and home-made, although with the same receiver it may occur under certain conditions and not under others.

"The effect is apparently caused by pick-up from the power line as well as from the antenna, although the nature of the interaction of these two pick-up voltages to produce the hum is not entirely clear. A poor
(Continued on page 342)

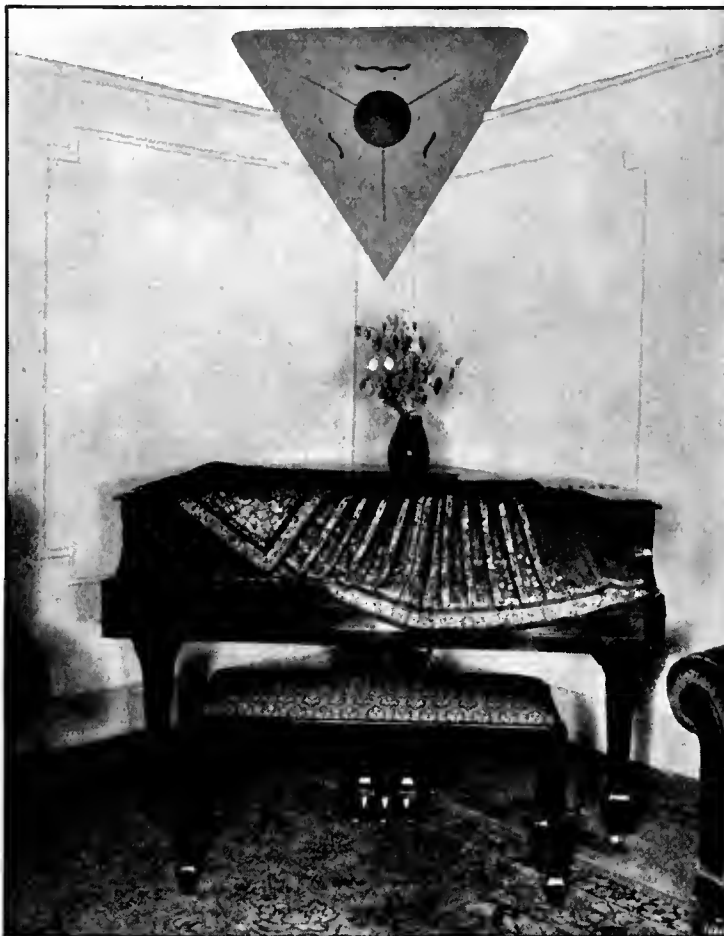

A method of mounting the moving coil loud speaker effectively from both esthetic and acoustic points of view.

REVOLUTIONARY!«

IN CONSTRUCTION AND PERFORMANCE

EVEREADY RAYTHEON 4-PILLAR TUBES

NOW you can sell your customers something really new . . . Eveready Raytheon Tubes! Let them hear the rich, full-voiced tone, the breath-taking realism of Eveready Raytheon reception. Demonstrate it, in their own radio sets . . . then tell them reception will *always* be better if they put a new Eveready Raytheon in each socket *whenever the tone begins to sound fuzzy*.

You can HEAR the difference and SEE the reason

Look at the illustration on this page, showing Eveready Raytheon's 4-Pillar construction . . . a sound improvement. See the solid, four-cornered glass stem, with the four rigid pillars imbedded in it, anchoring the elements. No other tube is permitted to use this construction, for it is patented and exclusive with Eveready



Raytheon.

Before the day of dynamic speakers and screen grid circuits, the old, flimsy, "gas-mantle" construction may have been satisfactory. But present-day radios need tubes with 4-pillar rigidity.

No legal entanglements!

Eveready Raytheons are licensed tubes. They come in all types, and fit the sockets in every standard A.C. and battery-operated receiver now in use. Ask your jobber, or write us now for the names of jobbers near you.

★ ★ ★

The Eveready Hour, radio's oldest commercial feature, is broadcast every Tuesday evening at nine (New York time) from WEAJ over a nation-wide N. B. C. network of 30 stations.

NATIONAL CARBON COMPANY, INC.

General Offices: New York, N. Y.

Branches: Chicago Kansas City New York San Francisco

Unit of Union Carbide  and Carbon Corporation

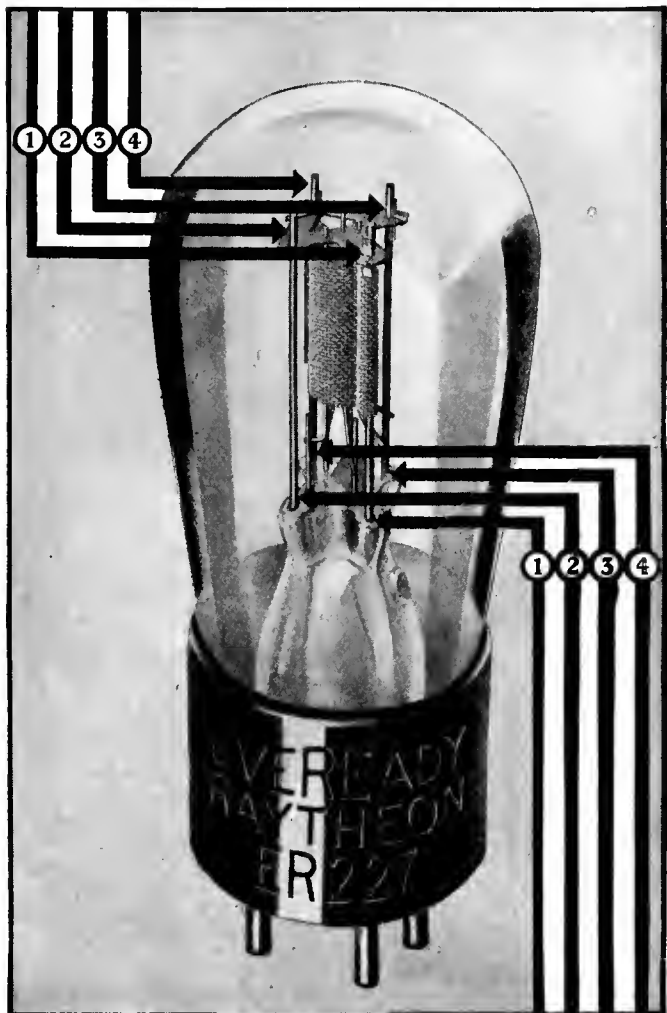

EVEREADY RAYTHEON

Trade-marks

(Continued from page 340)

grounded connection appears to accentuate the hum.

"The remedy is obvious—a filter in a power line to eliminate the pick-up from that source. This filter should be as close to the radio set as possible. In most cases, two 0.5-mfd. condensers connected in series across the power line, with the center tap connected to the ground post of the set, provide sufficient filtering (Fig. 1). In more obstinate cases, two radio-frequency chokes may be connected on the

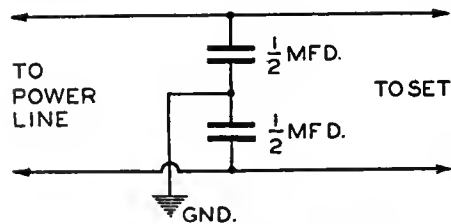

Fig. 1—An elementary r.f. filter for the power line.

line side of the condensers, as shown in Fig. 2. These chokes may be made by winding 150 turns of No. 18 d.c.c. wire in approximately seven layers on a form one inch in diameter.

"One word of caution: With such a filter, the ground post of the set is alive and the power-supply plug should be pulled out of its socket before any ground connections are made or changed. The slight current passing through the filter condenser to ground has practically zero power factor and consequently will not register on the meter, but when the ground connection of the set is open, the ground post of the receiver is at the potential of the line above ground, and a person making or changing ground connections is liable to receive an uncomfortable shock. The slight disadvantage of a "live ground" post on the set is more than offset by the improvement obtained in reception with receivers afflicted by this type of hum. That this is true is evident from that fact that certain manufacturers include filters of this type in their power packs to guard against the chance that the receiver may be operated under conditions which would tend to introduce the hum."

Servicing the Radiola

"Here are a few more service notes which may help my brother servicemen who are called upon to render service to Radiola purchasers, as well as users of other receivers. As complete as RCA service sheets are they do not provide solutions to the problems listed below:

"The first puzzling phenomenon was that of a Radiola 66, a receiver of the "superhet" type, from which came an unearthly racket of such intensity that a 1000-watt local transmitter could not even be heard. At first I suspected a faulty connection in the r.f. amplifier and I gave the set a very thorough test. Not a thing could be discovered. By chance I removed the dial light and upon trying the set again found that it was working satisfactorily. A new dial light fixed the trouble. In this connection it was curious to note that the dial light did not flicker or give any sign of defect.

"It may be that some of my brethren have had trouble with Radiola 44 and 46 screen-grid model receivers, such as lack of sensitivity or a resonance howl on tuning in a loud signal (a howl very much like that given out by a microphonic detector tube). Another trouble is poor volume and sensitivity at one part of the dial.

"In these receivers there are three small

trimming condensers with which the gang condensers can be lined-up. It will be noticed at times that a signal of 1200 kc. will come in very loudly but one at 600 kc., same power and distance, will not. No matter how the trimmers are adjusted there seems to be some discrepancy. To remedy this, loosen the two screws that hold the stator plates to the small strip of bakelite, move the stator plates a trifle closer to the rotor plates, and then reset the trimmers. It will be found necessary to move but one set of stator plates. To increase volume on the early models, increase the screen-grid voltage."

JAMES A. ROBINSON, Radiotrician and Radiola Dealer, Methuen, Mass.

R. L. MINOR, serviceman with the O. K. Houck Piano Company, Little Rock, Ark., keeps the ball rolling:

"A Radiola 46 was found which would work if the power unit was tilted but not if mounted normally. Examination disclosed a needle pointed tip of solder projecting from one of the terminals on the voltage divider resistor and penetrating the insulation of a lower potential wire beneath it when the weight of the unit was upon it. The needle point of solder and microscopic hole in otherwise perfect insulation eluded several careful examinations by the writer."

Data on Crosley Sets

Checking Up On The Showbox: "The Crosley Showbox has friction connections between the rotors and rotor terminals which should be checked occasionally and tightened if necessary. Also there are set screws on both ends of the variable condenser shaft, two on the dial wheel, and one on the other end which compress the springs responsible for keeping the sections in alignment. In case of low sensitivity on these receivers, give this your first consideration."

A. A. WILLITS, Willits Radio Service, Fort Dodge, Iowa.

"I was called in to service a seven-tube Crosley a.c. set. Upon testing with set

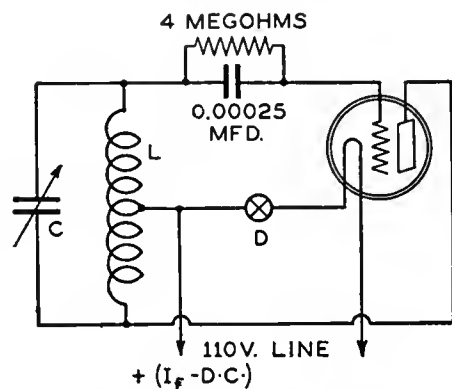

Fig. 3—A simple oscillator for general testing purposes.

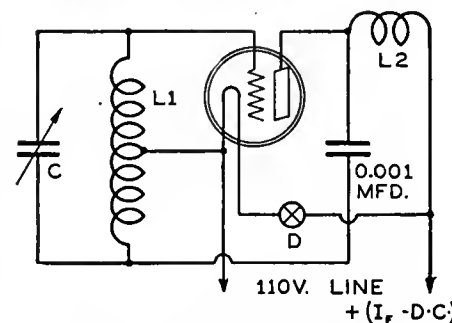

Fig. 4—A variation of Fig. 1 with parallel feed.

analyzer I found zero voltage on the plate of the first a.f. tube. After removing the receiver from the cabinet I discovered a rubber-covered resistor that, with the set turned on, got so hot that I could not touch it. I disconnected the condenser connected to it, tested it with 4.5 volts in series with a high-resistance voltmeter and found it shorted.

"I have found it pays to watch the condensers in the low-priced sets."

C. WASHBURN, Ja., Jacksonville, Fla.

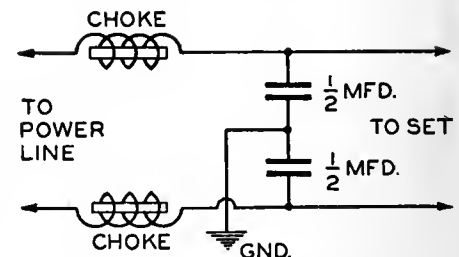

Fig. 2—Using r.f. chokes for additional filter action.

Two Simple Oscillators

The engineering department of the Jewell Electrical Instrument Company suggests the circuits illustrated in Figs. 3 and 4 as oscillator arrangements particularly adapted to the requirements of the serviceman.

In Fig. 3, the condenser C should have a capacity of approximately 0.0005 mfd. The coil L consists of approximately 50 turns of No. 20 double-cotton-covered wire, wound with a tap at 25 turns on a 2½-inch diameter tube. A 112A-type tube is used in connection with a 25-watt lamp D.

In Fig. 4, the condenser C should have a capacity of approximately 0.0004 mfd. The coil L₁ consists of approximately 100 turns of No. 22 enamelled wire wound with a tap at 50 turns on a 1¾-inch diameter tube. The coil L₂ consists of 100 turns of No. 28 enamelled wire, wound on a 1¼-inch diameter tube. These coils, if placed close to each other, should have their axes at right angles; that is, one should be mounted vertically and the other horizontally. A 201A-type tube is used in connection with a 25-watt lamp D.

When used on a 110-volt line, these oscillators will give an adequate signal for all ordinary testing purposes. If the supply is from a direct-current line, the signal generated will be a pure unmodulated high-frequency signal. If, however, the supply is from an alternating-current line, the signal will be a high-frequency signal modulated by the line frequency—60 cycles in most cases. This 60-cycle signal will be audible in the loud speaker of the radio set, but no sound will ordinarily be heard from the oscillator signal if the oscillator is operated on direct current.

An SOS to the Established Serviceman

With the exception of those working in a few very large cities, the serviceman in the employ of a radio dealer is underpaid. His salary averages between \$20.00 and \$25.00 per week. On the other hand, there is the independent serviceman who, generally starting with radio as a sideline, has worked up a clientele, and perhaps services for several different dealers. He collects a good commission on all parts used for replacement and nets a reasonably good living, often in excess of \$50.00 a week.

It is difficult to start one's own service business, but good servicemen are doing it everywhere. In many cases they have

supplemented their own independent business with contract work for dealers who are glad to be relieved of the necessity of maintaining their own service department. This is an advantage to the dealer, and certainly of value to the independent service organization. The arrangement often goes further than mere service, because a large number of service calls indicate the possibility of set or tube sales, and many who have a commission arrangement with the dealer on such sales as may be closed through leads furnished by them, are able to realize an income on selling in which they have responsibility.

What have our readers done in this respect? Perhaps the manner in which you solved your own servicing problems will be of vital assistance to some other serviceman sitting on the fence. Do you or do you not service for dealers? If you service for dealers, what are the terms of your contract?

How did your service start? What were the selling arguments you used in closing contracts with local dealers, and were these dealers making a profit, as far as you can determine, from their service departments? Did they prefer to have their service work done on contract because it was not possible for each individual dealer to secure a high-grade serviceman to do their individual work, or was the contract signed because of economies which you were able to effect for the dealer?

We are particularly interested in how you closed with the first dealer and the conditions leading up to this point. Do you operate from a central point with your own office, laboratory, and workrooms, or how is this done?

We are interested to know the methods by which dealers requiring service work turn over the orders to your organization. How many men do you employ? What is your scale of charges? How are collections from the ultimate customer made—by your organization or is the customer billed by the dealer whose work you do? Do you grant a commission on gross service charges to the dealers referring business to you or what is the arrangement? How does your scale of wages for servicemen compare with that paid by local dealers who are doing this work as part of their own retail organization?

It would be of interest to know what kind of service equipment you use: whether your set analyzers are purchased complete from one of the several manufacturers, or whether you use devices designed and built by yourself. How many of these analyzers are employed?

What proportion of repair work is done in the customer's home and what in your shop?

Your answers to these questions will be appreciated by fellow servicemen, and paid for by RADIO BROADCAST.

An Interesting Booklet

Under the title of "Fixed Resistor Replacement Problems," the International Resistance Company, 2006 Chestnut Street, Philadelphia, Pa., has published an interesting booklet on the resistor requirements of modern broadcast receivers. The text covers the importance of good resistors, their power carrying capacity, the noise factor, and how to determine the necessary resistance and current handling capacity required.

A Legal Question

The Radio Service Managers Association, with headquarters at 324 West 42nd Street, New York City, is gradually getting into swing. This is an organization with a membership made up of service managers and servicemen, providing a
(Continued on page 345)

"We found over a period of two years that CeCo Tubes were the most profitable to handle in more than one way."

Albert A. List, List Brothers, Distributors, Fall River, Mass.

"Give me any radio serviceman. Let him spend two hours alone in our 3½ acre plant... seeing for himself why million dollar equipment and 42 engineers are needed to make CeCo a decidedly better tube. Then—when he makes his next service call... there'll be a new set of CeCo Tubes installed."

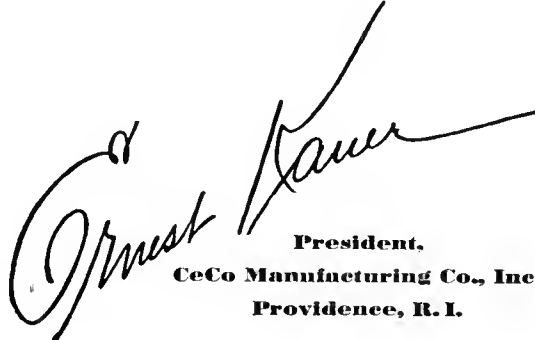
**President,
CeCo Manufacturing Co., Inc.
Providence, R. I.**

DO YOU KNOW?

1. Over 10,000,000 CeCo Tubes are in use today. The U. S. Government, ocean steamships, and countless commercial organizations are daily users of CeCo Tubes.

2. In the last 5 years CeCo has outgrown two sizable factories and now has the largest and most modern plant devoted exclusively to manufacturing of radio tubes.

The CeCo Couriers broadcast every Monday night at 8:30 P. M. Eastern Standard Time over the Columbia Chain from 22 stations. Listen in next Monday.

CeCo Tubes are licensed under the patents and applications of the Radio Corp. of America, General Electric Co., Westinghouse Electric and Mfg. Co. and Associated Cos.

CeCo

**1930
Radio Tubes**

BREMER TULLY MODELS S-81 AND S-82

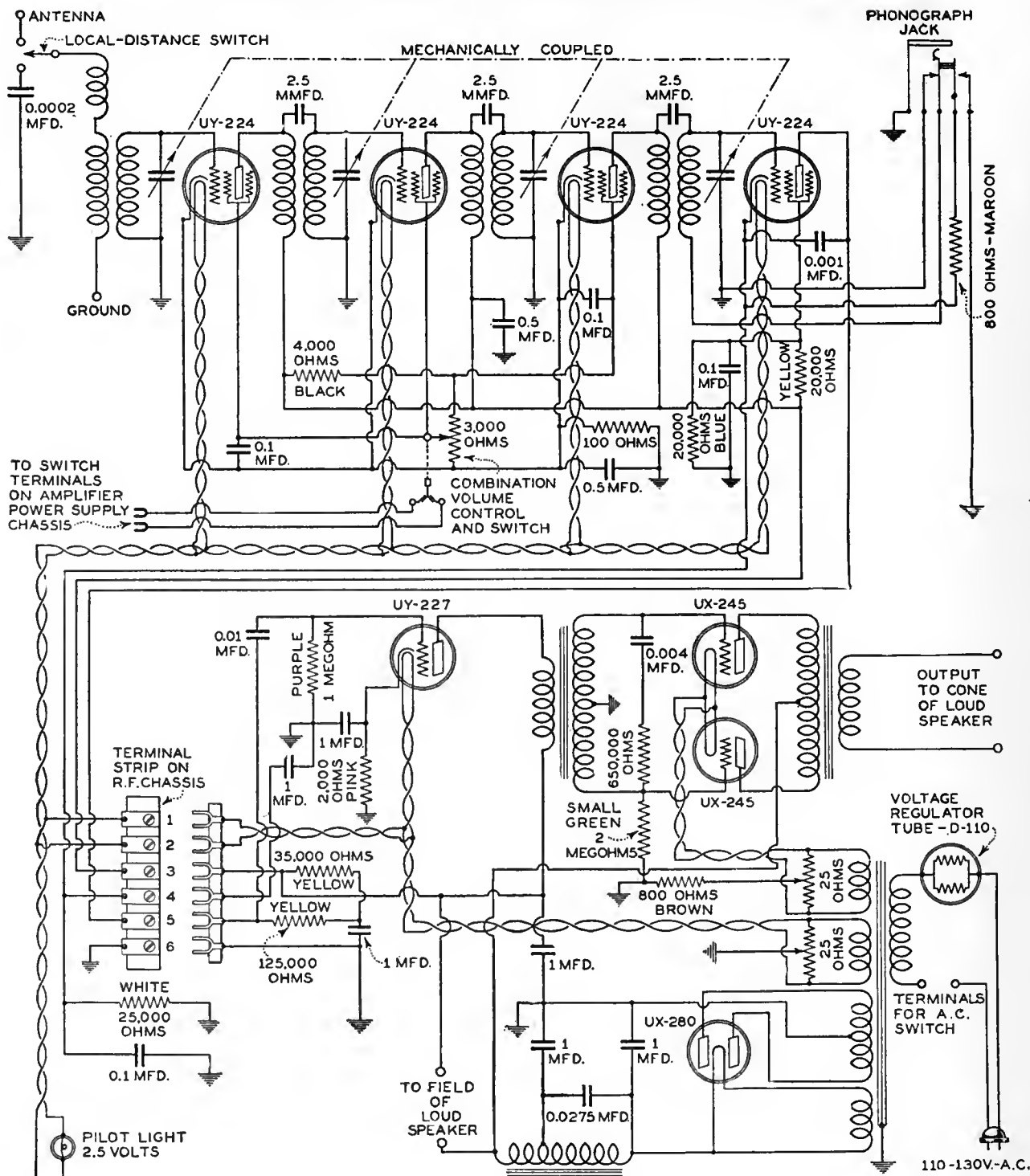

THE CHASSIS used in the Models S-81 and S-82 receivers is designed for the new a.c. screen-grid tubes. The radio-frequency circuit consists of three stages of tuned and shielded high-gain amplification using the a.c. heater-type screen-grid tubes (224). By the use of localized shielding and proper grounding (each rotor section of the tandem condenser assembly is individually grounded even though the rotors are electrically connected in a common grounded steel shaft) the chassis and tubes are made accessible and are unencumbered by unnecessary shielding. All wiring is rigidly secured in position under the automobile-type steel chassis and protected from interstage reaction by the use of secondary aluminum shields. All r.f. coils are matched to a standard and are interchangeable. Volume is controlled by increasing or decreasing the screen-grid voltage. A local-distance switch controls the sensitivity.

The power detector uses the grid-bias method of demodulation instead of the condenser-leak method. This is possible because of the tremendous amplification secured in the radio-

frequency amplifier. The power detector is a screen-grid tube.

The power detector is automatically biased for use as an amplifier for the reproduction of phonograph music when the magnetic pick-up unit is plugged into the jack provided at the rear of the r.f. chassis. Any good high-impedance pick-up unit provided with a volume control may be used.

AVERAGE VOLTAGE READINGS					
Type of Tube	Position of Tube	A Volts	B Volts	C Volts	Normal Plate mA.
227	1st R.F.	2.5	150	12	5.5
227	2nd R.F.	2.5	150	12	5.5
227	3rd R.F.	2.5	150	12	5.5
227	Detector	2.5	45	0	3.4
227	1st A. F.	2.5	145	9	3.6
245	1st P-P	2.4	240	27	30.0
245	2nd P-P	2.4	240	27	30.0
280	Rectifier	5.0			
D98	Ballast				

The audio-frequency amplifier consists of two stages. The first stage of amplification is resistance coupled to the detector tube, and employs a heater-type tube of the 227 type. The power amplifier employs two 245-type tubes in a push-pull amplifier circuit. All amplifying tubes and the detector tube have automatic grid-bias control which compensates differences in current drain from the rectifier system.

The power pack supplies all required voltages to the seven receiving tubes and energy for the field of the electrodynamic loud speaker. The Duresite type No. 110 voltage-regulator tube maintains a constant voltage across the primary of the power transformer, and protects the other tubes in the receiver from line voltage changes between 98 and 130 volts.

The direct current filter system is tuned to remove all trace of a.c. ripple. The loud speaker field acts as an additional choke in the filter system, and also furnishes the necessary resistance to reduce the high voltage for the two 245 tubes to the correct value for the r.f. and a.f. amplifier tubes.

(Continued from page 343)

rating for the latter, by examination, which, when the organization gains recognition, may be of significance.

The organization publishes *The Radio Service Man*, which is sent only to members. It is suggested that servicemen interested in joining, communicate with the association. The dues for the grade of membership in which the average reader will be interested are \$5.00 per year with a \$2.00 initiation fee.

The January issue of *The Radio Service Man* presents an interesting problem:

"A customer resides in a home not equipped with base outlets. She has been given to understand by the salesman that the set will be installed.

"She shows the installer where the set is to be installed. (Fifty feet from the nearest current source.)

"He explains to her the advantages of locating near the current supply, calling to her attention the fire rules regarding same.

"The customer refuses to change her mind and the serviceman has her call the shop.

"In some cases the policy is to install no matter how. The shop tells the man to go ahead.

"O. K.," says he, taking from his bag eight feet of lamp cord and adding to this No. 18 rubber 'plated' lead-in wire, (twisted as well as possible).

"There are many cases where men don't even go through the preliminary of calling the office.

"Reaching for the chandelier he lets down the canopy and makes an unsoldered wrap splice. In retaping the splice he neglects to use rubber tape, substituting ordinary friction.

"Now just suppose this wiring acquired a partial short and caused a fire.

"The New York Fire Department code limits the length of this wire to 12 feet.

"The insurance companies state explicitly in their policies that all wiring must conform with existing regulations regarding same.

"Who pays?"

"We are not lawyers and don't attempt the answer, however we feel that there is food for thought in the foregoing."

More "Dope" on Noise

Seventy-five per cent. of all contributions to "The Serviceman's Corner" are concerned with the elimination of noise in one form or another. This is probably sig-

nificant of the extent to which this trouble is prevalent in the category of radio difficulties. The possibilities of noise were analyzed in considerable detail in the "Corner" for January, 1930. The following contributions may be considered supplementary to this "Symposium."

HUM IN RADIOLAS

"I have found from extensive experiments on Radiola 44 and 45 receivers, that the hum can be reduced by connecting an 0.5-mfd. condenser from terminal No. 6 on the socket-power unit (the maroon colored wire) to the common ground. This doubles the capacity across the detector cathode, and does the trick.

"The Radiola 66 receiver can also be improved upon in this respect. Add an 0.25-mfd. condenser across the 220-ohm reactor coil (the choke nearest the 280) by connecting one lead from the condenser to one terminal of the 280 filament lead and the other to the midtap of the two chokes." (The center tap on the 280 filament winding is to be preferred to one leg of the filament.—Ed.)

A. J. BARRON, Radiotrician and Electrician, Shawnee, Oklahoma.

THE VICTOR HUMS

H. W. HUDELSON, Auto and Radio Service, Vandalia, Mo., a veteran contributor to the "Corner," lends us a hand here.

"We find that the Victor is hard to fit with a humless 27-type detector tube, and even when we succeed in getting a good tube, with the hum considerably reduced by means of the hum adjuster, another source of trouble is often in evidence. The next thing to do is to throw on the phonograph switch, cutting out the chassis, and adjust the hum control on the amplifier. If this does not eliminate the hum, pull out the chassis and power unit, and resolder all connections, regardless of how secure they may appear. Hold the iron on the joint until every bit of resin has been driven out. This cures the hum in about 99 cases out of a hundred."

(Offhand it is difficult to justify this cure. But we accept it on its face value from an expert with Victors.)

THE POWER PACK IS GUILTY

"When the metal casing is off the power pack of some of these compact electric sets, so the pack can be tested with the set in operation, a pronounced hum is present in the output. This is usually due to coupling between the rectifier and the detector tubes, which can be reduced

by placing a small grounded metal sheet between these tubes, or by covering the rectifier with a shield. In sets having the rectifier in the open it may pay to shield this tube permanently."

CLAUDE AUSTIN, Austin Radio Service Portland, Oregon.

THE POWER AMPLIFIER

"I recently had some very unusual experiences with a power amplifier that I believe will help some of the readers of the 'Corner.'

"The amplifier in question developed a terrible crackling sound, very similar to static, and a check on all tubes showed them to be in first-class condition. This amplifier, employing a 227-type tube in the first stage and two 210-type tubes in push pull as the final stage, was used with a superheterodyne receiver and was equipped with a switch to connect the input to either the radio or an electric phonograph pick-up.

"This crackling noise showed itself only when the radio set was connected to the amplifier and this would, naturally, indicate that the trouble was in the radio set itself. However, a thorough test of every tube and part in the set placed the trouble in some other section. This seemed illogical in view of the fact that the amplifier performed satisfactorily when the electric pick-up was being used.

"As a last resort I suspected the first stage a.f. amplifier, although nothing seemed to indicate such might be the case. A new transformer was tried and the trouble disappeared. Just why the transformer was noisy on the radio set and not on the pick-up is still a mystery to me."

CHAS. H. JENKINS, JR., Radio Service

Since 1914, Audubon, N. J.

(A carrier wave sensitizes a set to disturbances in any part of the system.—Ed.)

J. NOONAN sends along a few corroboratory lines: "A case of interference manifested itself in a peculiar grating sound which seemed to keep time with the music received. The receiver was tested several times and no trouble could be found. The difficulty was finally located in a lamp which was on the top of the set. The lamp was a two-candle affair, with two shades which were suspended from metal brackets. The vibrations from the electrodynamic loud speaker set the two shades swinging. The shades rubbing on the metal standards generated static discharges which were quite easily heard in the receiver."

THE INVESTOR LOOKS AT RADIO

(Continued from page 329)

and Kolster, the passing of the dividend of Brunswick-Balke-Collender, and the withdrawal of Eveready from manufacturing are indicative of the general situation in the industry. If large inventories are written off, it is probable that earnings of most companies for 1929 will be considerably below those for 1928. At this writing few reports have been published but a report from Crosley showed actual and per share earnings for 1929 less than one third those for 1928.

One of the most hopeful new developments is the use of vacuum tubes for purposes other than radio receiving and transmitting. These tubes are essential in telephone and telegraph systems; in the production and reproduction of talking pictures; in the metering of gas and electricity; in detection of flaws in metal; in the matching of color; in the practice of light therapy in medicine, and in the chemical industry. New developments are constantly

taking place but it is probable that the profits derived from all these minor uses will not equal those derived from the sale of receiving apparatus for many years.

The immediate prospects for the industry appear, therefore, to be for lower earnings, with a probable consolidation or elimination of some of the weaker companies in the field. Over a period of years, the outlook is much more promising but before real progress can be made disposal must be made of surplus stocks and the industry as a whole, placed on a firm financial basis. It is a practical certainty that a number of the stronger companies will survive and for them earnings will show a normal increase over a period of years, but it is still too early to speculate on the outcome of some of the weaker companies in the field, especially when total income is dependent on radio production. In a succeeding article we shall outline the position of the Radio Cor-

poration of America, giving reasons why we think it more attractive than some others for long-term holding, and in subsequent articles, we shall discuss other companies whose securities appear fairly priced, but in general, we should use the greatest discrimination in buying stocks of radio companies unless the purchaser knows them to be more favorably situated than the average.

Asks Wavelength For Ship-to-Shore Phone

Predicting a growth in two-way radio telephone between ship and shore, Frank B. Jewett, president of the Bell Telephone Laboratories urged the Commission to set aside a block of 48 frequencies for such service. He recommended that channels for different services be grouped in blocks rather than staggered throughout the spectrum as at present.

GREBE SK-4 SUPER-SYNCHROPHASE RECEIVER

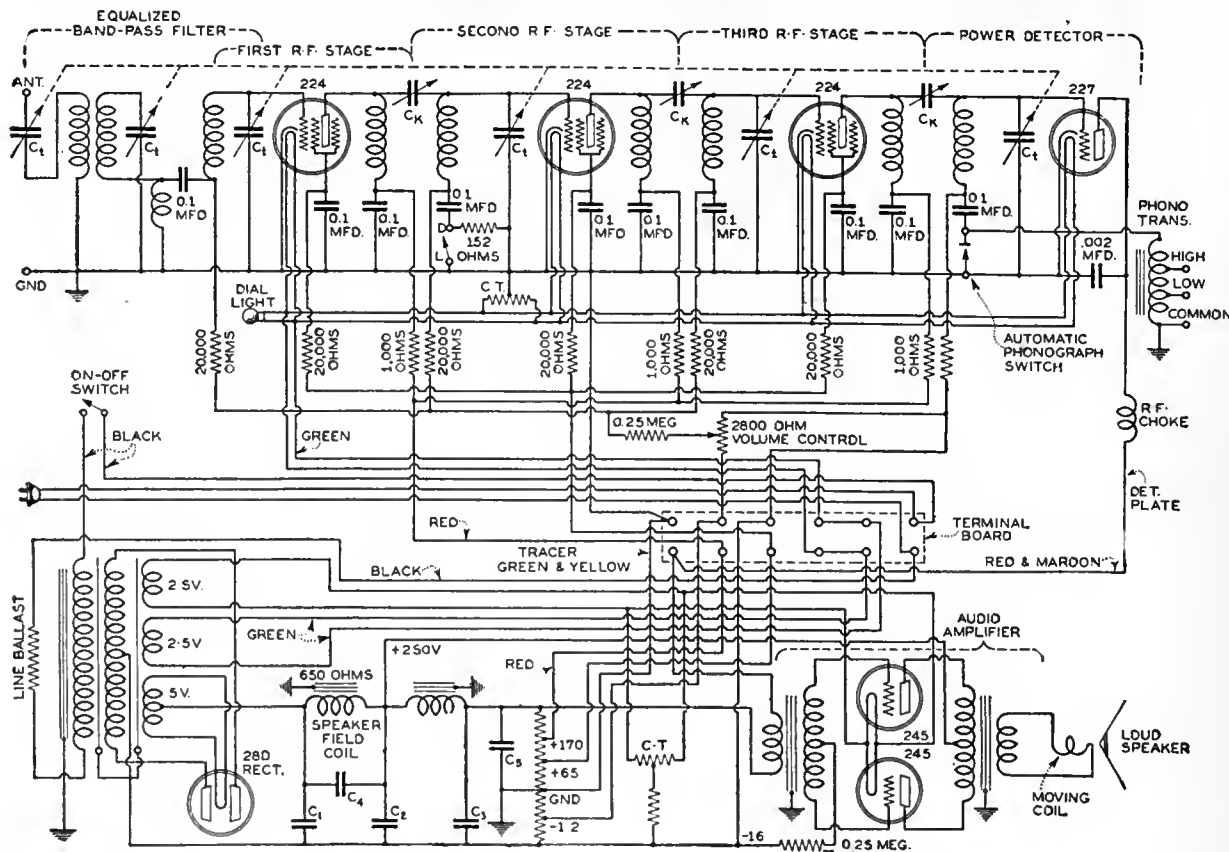

THIS RECEIVER consists of a three-stage screen-grid r.f. amplifier, a type 227 detector, and a push-pull output stage using two 245-type tubes supplying power to an electrodynamic loud speaker. The receiver contains several unusual features.

R.F. Amplifier

Preceding the first screen-grid radio-frequency amplifier tube is a band-pass filter circuit consisting of two tuned circuits coupled by both capacity and inductance. Tuning condensers associated with these band-pass circuits are marked C_t on the diagram and these circuits function to prevent any signals other than those from the desired station from being impressed on the grid of the first r.f. amplifier tube. Highly selective circuits of this type are used, especially in connection with the screen-grid r.f. amplifiers, because these tubes tend to produce cross-talk. Cross-talk is eliminated if the circuits preceding the first tube are sufficiently selective to prevent practically all signals other than the one desired from being impressed on the first tube. To obtain this high selectivity simple tuned circuits might be used but these would produce sideband suppression. By the use of band-pass circuits, high selectivity without sideband suppression is obtained.

Impedance Coupling

The following tubes in the r.f. amplifier are impedance coupled, that is, a tuned circuit is in the plate circuit of each tube. The plates are choke fed and the tubes are coupled to the tuned circuits through small adjustable condensers, C_k. The condensers are, of course, properly adjusted at the factory and need only be altered in the event that the set has been tampered with or the adjustments have been altered due to rough handling.

Detector Circuit

The detector, using a 227-type tube, is of the plate-detection type. In the grid circuit of the detector tube a phono-graph pick-up transformer is connected with two taps to make it suitable for use with either low- or high-impedance pick-up units. In normal operation as a radio receiver this transformer is shorted out of the circuit by the phono-graph switch. When the set is to be used with a phono-graph pick-up unit this switch is opened and the phono-graph pick-up transformer is thereby connected in series with the grid circuit of the detector.

A.F. Amplifier

The two 245-type power tubes obtain a.f.

signal voltage from the secondary of the a.f. transformer, the primary of which is connected in the plate circuit of the detector tube. Since push-pull amplifiers sometimes have a tendency to oscillate, a ½-megohm resistor is connected in

series with the center tap of the secondary of the transformer. This resistor prevents the circuit from oscillating but has no effect on the audio-frequency characteristics of the amplifier.

READINGS WITH WESTON SET TESTER MODEL 547

Type Tube	Tube Position	A Volts	B Volts	C Volts	Screen Volts	Screen Current	Cathode Volts	Normal mA.	Grid Test mA.
224	1 R.F.	2.4	155	0.2	38	0.5		2.8	32.0
224	2 R.F.	2.4	150	0.2	38	0.5		2.8	3.0
224	3 R.F.	2.4	150	0.2	38	0.5		2.8	3.5
227	Det.	2.4	180					0.5	1.4
245	P. P.	2.4	225	*				37.0	42.0
245	P. P.	2.4	225	*				37.0	42.0
280	Rect.	4.9							50.0 per anode

Line Voltage = 116

*No bias reading at socket due to resistance in series with grid.

Bias can be read with voltmeter lead connected between filament and chassis.

READINGS WITH JEWELL SET ANALYZER MODEL 198

Readings with Plug in Socket of Set and Tube in Tester

Type of Tube	Position of Tube	Tube Out A Volts	Tube Out B Volts	C Volts	Cathode Heater Volts	Normal Plate Volts	Plate mA.	Grid Test	Plate Change mA.	Screen Grid Volts
224	1 R.F.	2.7	195	2.35	188	14	0	2.0	2	57
224	2 R.F.	2.7	195	2.35	188	14	0	2.0	2	57
224	3 R.F.	2.7	195	2.35	188	14	0	2.0	2	57
227	Det.	2.7	195	2.35	210	x	0.8	0.8	0	
245	1 A.F.	2.7	270	2.35	245	x	30.0	34.0	4	
245	2 A.F.	2.7	270	2.35	245	x	30.0	34.0	4	
280	Rect.	7.0		5.2		x	90.0			

Line Voltage = 120. Volume control position Min.*

Note: x Resistors in circuit prevent readings.

Note: *224 plate current read with volume control at maximum position.

READINGS WITH A SUPREME RADIO DIAGNOMETER

Type Tube	Tube Position	A Volts	B Volts	C Volts	Screen Volts	Normal mA.
224	1 R.F.	2.4	155	0.2	38	2.8
224	2 R.F.	2.4	150	0.2	38	2.8
224	3 R.F.	2.4	150	0.2	38	2.8
227	Det.	2.4	180			1.5
245	P. P.	2.4	225	*		37.0
245	P. P.	2.4	225	*		37.0
280	Rect.	4.9				50.0

Line Voltage = 116

*No bias reading at socket due to resistance in series with grid. Bias read with voltmeter lead connected between filament and chassis.

MEASUREMENTS OF H. F. RESPONSE

(Continued from page 314)

kilocycles at which a normal output of 50 milliwatts is obtained at 10 and 100 times the resonant amplitude for normal output.

It will be observed that none of the one-audio-stage sets or none of the sets employing a low-gain, two-stage, audio-frequency amplifier shows appreciably better low-frequency response than the sets employing two high-gain, transformer-coupled, audio-frequency stages. Less hum is obtained, to be sure, but no great improvement is noted in low-frequency response. In other words, the design of the audio-frequency amplifier in these receivers is in essence very much the same, although it might be expected that, since only one a.f. transformer is employed, and the squaring action of deficiencies occurring in two transformer stages is absent, a much better frequency characteristic would be obtained.

This is substantiated by an examination of the high-frequency end of the fidelity curves for 1200 kc. These curves represent, as stated above, the frequency characteristics of the a.f. amplifiers in the respective receivers. With two exceptions, namely Figs. 3 and 4, the high-frequency response of the sets employing two transformer-coupled stages and grid-leak detection, is practically as good as that in receivers employing one audio-frequency stage or two low-gain stages and C-bias detection. It would appear, therefore, that the maximum possibilities of one-stage, audio-frequency amplifiers, or low-gain, audio-frequency amplifiers have not been exploited as yet in most recent receivers. These possibilities, so far as high-frequency response of the audio-frequency system itself is concerned, are illustrated by the 1200-kc. fidelity curve of Fig. 4.

A glance at most of these fidelity curves shows that, whereas a response of anywhere from 50-80 per cent. is generally obtained at 100 cycles, and 30-50 per cent. at 60 cycles, the transmission at 3000 cycles is only of the average order of 20 per cent. In fact, in some instances 4000- and 5000-cycles transmission is of a negligible order. If this deficiency were due only to poor audio-frequency response the difficulty could be resolved very quickly. But even with a very good high-frequency response in the audio-frequency end, as in Fig. 4, the fidelity at 600 kc. is very poor at the high frequencies.

Sideband Suppression

The primary source of high-frequency loss is in sideband suppression due to sharpness of resonance. This is all the more noticeable when the straight audio-frequency characteristics of the set are very good, as in Fig. 4. But even when the audio-frequency characteristics are not of the best, as in Figs. 1 and 7, there is considerable high-frequency loss as shown by the difference in the 1200-, and 600-kilocycle fidelity curves. The severity of sideband suppression is illustrated in any of the attached curves, which show that suppression starts as low as 1000 cycles.

Sideband suppression may be very bad even in receivers which do not have a very high degree of selectivity. Thus Fig. 3 illustrates a receiver with exceptionally fine audio-frequency characteristics. Its selectivity, as shown by the band widths, is not all that can be expected of a four-tuned-circuit set. Nevertheless, the 600-kc. fidelity curve shows very noticeable drop in high-frequency response. However, even with this loss its high frequency response is very good. This illustrates that the only way to retain good high-frequency response even with sidebands cut off

is to start out initially with an abundance of these frequencies, as in this receiver.

The degree to which the 1200-kc. and 600-kc. fidelity curves depart is not always a measure of the degree of sideband suppression, and therefore of sharpness of resonance. Thus, Fig. 4 illustrates a receiver with very good high-frequency characteristics and a very marked amount of high-frequency cut-off due to sideband suppression. The 1200- and 600-kc. curves are very wide apart. Figs. 1 and 7, on the other hand, illustrate receivers with approximately the same high-frequency response at 600 kc., these receivers differing appreciably in selectivity. While a great deal of sideband suppression is present, most of the loss in these sets occurs in the audio-frequency system, and consequently the 1200-kc. and 600-kc. fidelity curves for each set are closer together.

Selectivity vs Suppression

It is of interest to note that two receivers having approximately the same selectivity, as expressed by the figure of merit advocated by the proposed I. R. E. standards and indicated for each receiver on its curve sheet, do not necessarily show the same degree of sideband suppression. Thus sets 4 and 5 have approximately the same band widths at 600 kc., yet the former shows markedly more sideband suppression than the latter. This is because receiver 4 is much sharper than receiver 5 at or very near resonance, whereas off resonance they both show nearly the same selectivity characteristics. This difference is probably due to the use of an extra tuned stage in receiver 5, each stage being broadly tuned and the overall resonance curve being flat at resonance and sharp off resonance.

It might be stated that in spite of the noticeable lack of high frequencies, these receivers sound very good. While this is true in some cases the sets would sound immeasurably better if they reproduced the high frequencies to a greater extent. When they do sound good it is probably due to a considerable amount of compensation introduced by the loud speaker which reproduces the high frequencies better than the low frequencies. As often as not, however, the sets do not sound so good, especially when the loud speaker is not efficient at high frequencies. As one distributor of radio sets put it, "Radio sets are made so that a canary bird sings bass."

Unfortunately the strict selectivity requirements imposed upon radio receivers necessitates sharp resonance characteristics with resultant high-frequency suppression. Until band-pass filters with square-top resonance curves and sharp cut-off are better developed it seems that the only way to secure the higher frequencies is to design the audio-frequency system with rising characteristics or introduce the necessary compensation in the loud speaker.

The one strong objection most frequently heard against real good high-frequency response is the introduction of excessive noise and tube hiss, the high-frequency components of which are predominant. For loud signals, where the amplification of the receiver can be considerably reduced, this is not at all important. This objection is valid wherever weak signals are concerned, but in such cases reception cannot be very entertaining, to say the least, and it seems wrong to have to penalize radio sets in the way of high-quality reproduction in order to eliminate noise arising in distant reception.

The reader may be interested to know that the curves which accompany this article were made from actual measurements on standard radio receivers taken directly from stock.

TESTING

INSTRUCTIONS

FOR SERVICE MEN



For use with

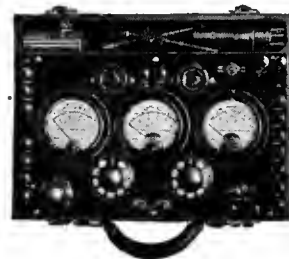

Model 547

RADIO SET TESTER

This Instrument, and this Manual which is furnished with it, together provide the most complete and up-to-date equipment available for servicing radio receivers. Electrical data for practically every set on the market is contained in this book—which is made up in loose-leaf form so that purchasers of the instrument who turn in registration cards are automatically supplied with latest information.

This instrument has achieved wide success among dealers and service men. It is preferred because of its dependability, ingenious design providing ease of operation, compactness and light-weight portability. It will make all the required tests on any A. C. or D. C. set. Durable bakelite case and fittings. Provided with 3 1/4" diameter instruments.



THE BALKETT MODEL C

An interesting feature of this receiver is the use of double primaries on all of the radio-frequency transformers. In all cases the two primary windings are connected in series and an 0.00025-mfd. fixed condenser is connected across one of the primaries. These two windings are used to

obtain uniform r.f. gain over the entire broadcast band, the capacity shunted winding being most effective at low radio frequencies and the unshunted winding being most effective at high radio frequencies, thus the inefficiency of each winding is compensated by the other.

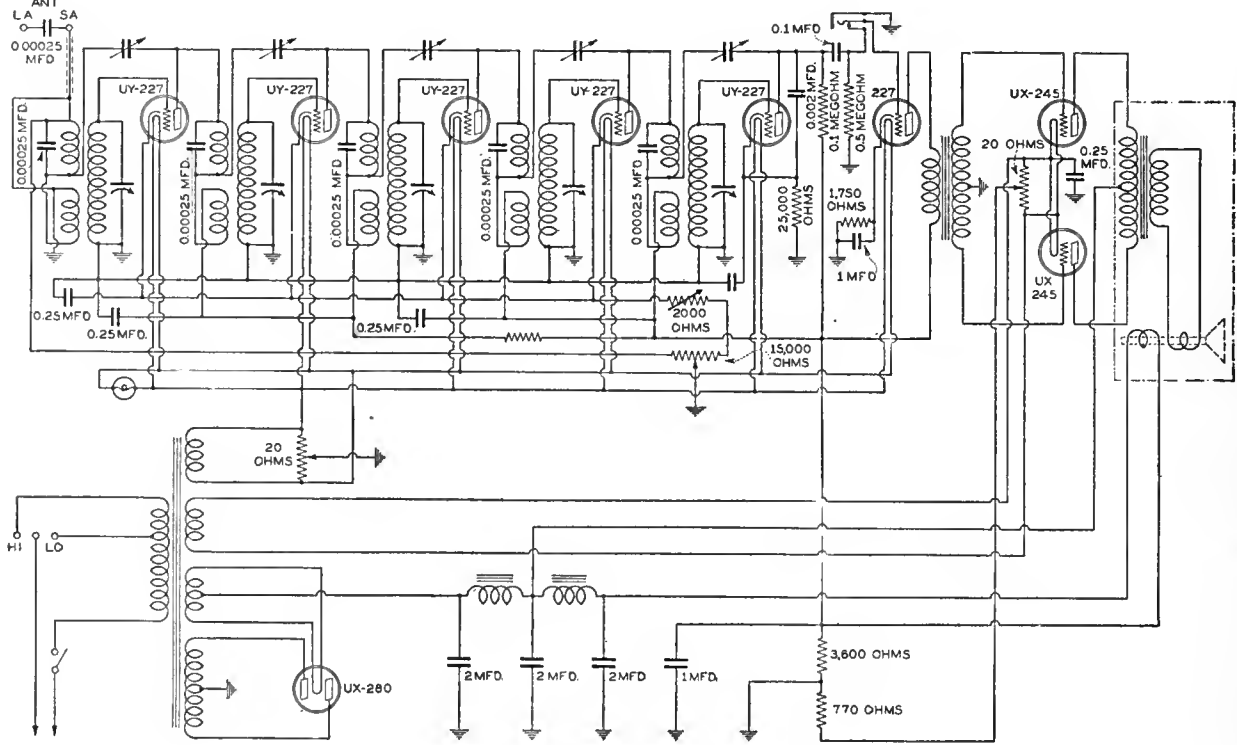

THE KENNEDY CHASSIS NO 10

This is a screen-grid receiver using three 224-type tubes as r.f. amplifiers followed by a C-bias detector, one resistance-coupled a.f. stage, and one transformer-coupled a.f. stage. Note the r.f. filter in the detector

output consisting of an r.f. choke and two fixed condensers, such a filter being essential when the detector is resistance coupled to the following amplifier tube.

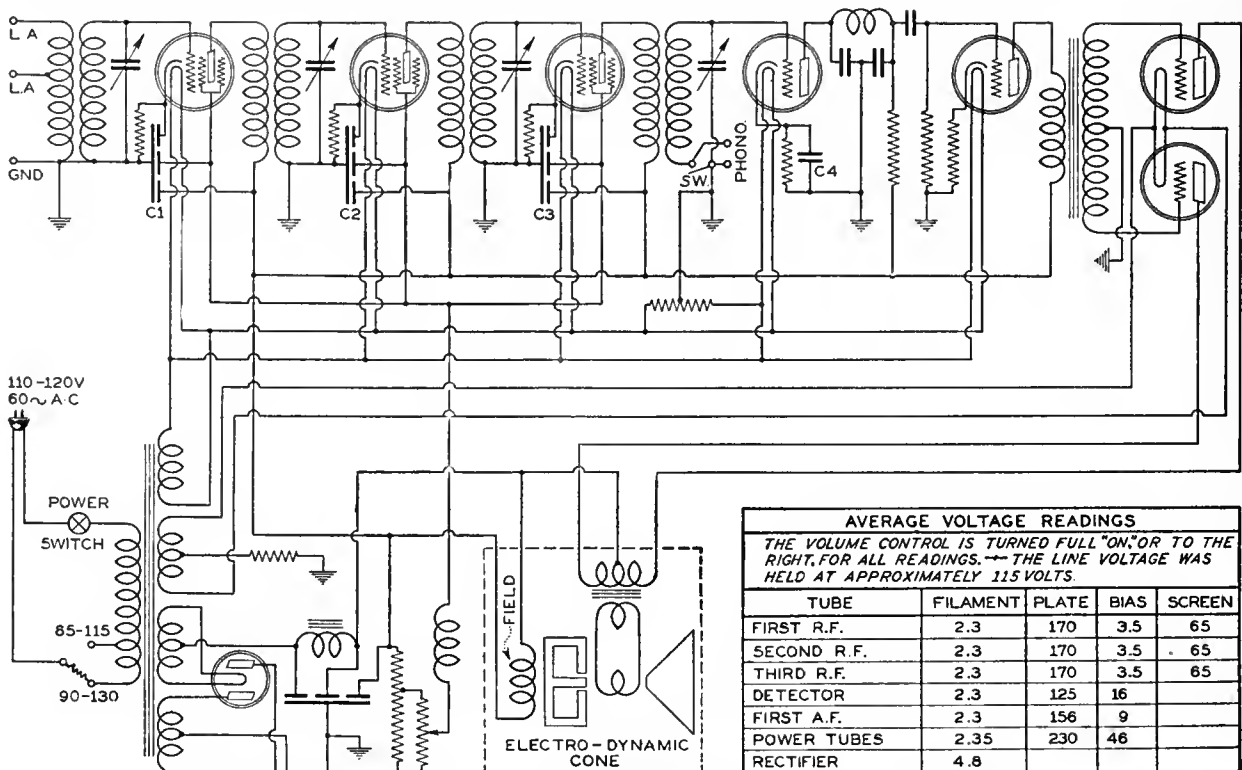

AVERAGE VOLTAGE READINGS				
THE VOLUME CONTROL IS TURNED FULL "ON" OR TO THE RIGHT, FOR ALL READINGS. -- THE LINE VOLTAGE WAS HELD AT APPROXIMATELY 115 VOLTS				
TUBE	FILAMENT	PLATE	BIAS	SCREEN
FIRST R.F.	2.3	170	3.5	65
SECOND R.F.	2.3	170	3.5	65
THIRD R.F.	2.3	170	3.5	65
DETECTOR	2.3	125	16	
FIRST A.F.	2.3	156	9	
POWER TUBES	2.35	230	46	
RECTIFIER	4.8			

BAND-PASS FILTER CIRCUITS

(Continued from page 328)

The loss of amplification due to the use of an extra filter is considerably greater than 50 per cent. The variation in selectivity, however, is now only in the ratio of 2.6-1, and it has been increased to about three times at the lower frequency; the sideband variation at this frequency is about the same, but at 1200 kc. it has been reduced to 15 per cent.

It is doubtful whether the extra selectivity is justified in view of the loss of amplification which accompanies it, particularly as the selectivity with only the single filter and two tuned plate circuits is fairly high. It can be seen, however, that the capacitatively coupled filter enables a very great increase in selectivity to be made at the higher frequencies without increasing the sideband variation at the lower frequencies. Indeed, by the use of suitably designed capacitatively coupled filters for all the tuning circuits in a receiver, it would be possible to make a receiver with constant selectivity throughout the whole broadcast band. This would be quite impossible with inductive coupling.

Other Advantages

From the foregoing it will be seen that the use of capacitatively coupled filters in place of the usual cascade tuned circuits allows, not only of greater fidelity, but also of greater selectivity at the higher broadcast frequencies. While inductive coupling permits the retention of sidebands, it does nothing to correct the low selectivity at high frequencies.

Another advantage is gained by the use of filter circuits instead of cascade circuits; it becomes somewhat easier to obtain satisfactory linking up of the variable condensers. The effect of misalignment with cascade circuits is a loss of amplification and selectivity. With filter circuits the effect is rather different. Misalignment causes the tuning curve to become asymmetrical; consequently, the selectivity becomes greater on one side of resonance than on the other. Indeed, the selectivity on one side may become greater than that with perfect alignment. Owing to the flat topped curve, a slight amount of misalignment does not appreciably affect the amplification. Perfect alignment, of course, is just as difficult to obtain with band-pass filters as with cascade circuits, but the effects of slight misalignment are not usually so serious.

STRAYS FROM THE LABORATORY

(Continued from page 333)

curves were somewhat incorrect. The lowest section of the logarithmic ordinates of the selectivity curve, Fig. 1, was contracted—a correct curve will be found in Fig. 3. In the case of the fidelity curve, the point on the abscissa marked 80 cycles should have been marked 30 cycles. If this change is made the fidelity curve is correct.

Pentode Articles

The following articles and notes on the Pentode tube may be of interest. They all appeared in RADIO BROADCAST.

November 1928, Henney "New Trends in Radio 1929-30."

April 1929, "Strays from the Laboratory," "Characteristics of Philips Pentodes."

July 1929, "Strays from the Laboratory," "Characteristics of Mullard Pentode tubes."

October 1929, "Strays from the Labora-

tory," "Output from Pentodes Using Igramic Output Transformers."

October 1929, Cocking, "Possibilities of the Pentode Tube."

December 1929, Roth, "Development of the Pentode Tube."

March 1930, Henney and Rhodes, "Characteristics of Pentodes."

T.R.F. Articles

A list of articles dealing with the tuned-radio-frequency amplifier which have appeared in the I.R.E. *Proceedings* is given below.

"The Shielded Neutrodyne Receiver" by L. A. Hazeltine, June 1926.

"Method of Maximization in Circuit Calculation" by Walter Van B. Roberts, October 1926.

"Selectivity of Tuned-Radio-Frequency Receivers" by K. W. Jarvis, May 1927.

"Mathematical Study of Radio-Frequency Amplifiers" by Victor G. Smith, June 1927.

THE MARCH OF RADIO

Continued from Page 317

profit. In other words, with 25 per cent. of its time sold, the Columbia system succeeds in breaking even.

Bookkeeping methods have a lot to do with how an annual statement comes out. However, in the case of the N. B. C. it is difficult to see, under the circumstances, how it can help but show a very substantial profit, in spite of its lavish use of high-priced space and such luxuries as Schumann-Heink's services as operatic counsel.

The N. B. C. could, if it would, perform a great service to the public by soft pedaling the blatant advertising in practically every program broadcast during the choice evening hours. Addressing the advisory committee, which meets once a year to hear Mr. Aylesworth's accounting of his stewardship, the president of the N. B. C. reported a gross revenue of \$15,000,000 during 1929. The personnel of the company increased from 558 to 917, and clients from 96 to 199. The permanent network involves 32,500 miles of telephone lines, linking 73 stations. The outlet stations concentrate almost entirely on presenting advertising features and this probably accounts for the recent reduction of 50 per cent. in the charges made for sustaining programs.

Evidently the advertising profession has accepted radio and therefore the custodians of the medium can, if they will, do a little housecleaning before the public refuses to listen to the spoken word over the air. The courageous act of publicly throwing somebody off the air (especially if there is a customer waiting to step in for the particular hour involved) would effect a salutary warning to the advertising profession. The entertainment value of broadcasting and, in consequence, the effectiveness of program sponsorship and the sales of radio receivers would be markedly stimulated if advertising announcements were restricted to ten seconds, once each ten minutes. No one would bother to tune out short announcements.

The present policy of radio advertising is to say more and more to fewer and fewer. The more intelligent policy would be to say less words of greater effectiveness to the greatest possible number. The painful thing about radio advertising is the growing length of the advertising dose handed out with each announcement. The public does not react unfavorably to a few words of the most direct kind of advertising. The loudest groans are caused by the tediously long announcements which are now the custom.

Just Out . . . Keith Henney's Book on Radio

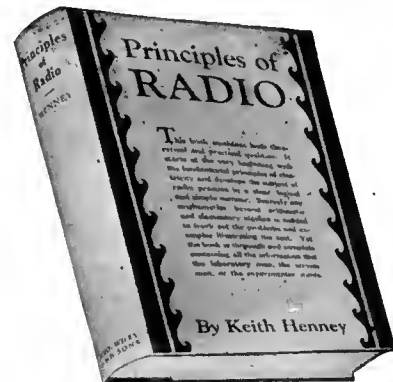

Principles of Radio

By KEITH HENNEY

Director of the Laboratory
Radio Broadcast Magazine

Readers of Radio Broadcast, long familiar with the work of Keith Henney in his capacity as Director of the Magazine's Laboratory, will be eager to secure his first book, just released from the press.

This book brings together within one cover the kind of information on radio which will appeal to the practical interest of every radio experimenter, technician, engineer, and fan. It contains the latest data and the most modern methods. It treats in a thoroughly practical way everything from the production of radio currents to their reception and transmission. Many problems, examples, illustrations, experiments, are here presented in book form for the first time.

Keith Henney, by reason of his wide experience as an operator, engineer, and writer, has the gift of making technical information readily understood by the reader.

See a Copy on Ten Days'
Approval

Price \$3.50

A Wiley Book

ON APPROVAL COUPON

JOIN WILEY & SONS, INC.
440 Fourth Ave., New York City

RB 4-30

Gentlemen: Kindly send me on approval Henney's "Principles of Radio." I agree to remit the price (\$3.50) within ten days after its receipt or return the book postpaid.

Name

Address

Reference

RADIO

TUBE MAKERS DEFEND THE PENTODE

Three tube makers in the United States have offered pentode tubes. They are Arcturus, Champion, and CeCo. Tubes of the first two companies are power tubes to be used only as audio-frequency amplifiers. The CeCo tube is designed for radio-frequency amplification. We are glad to present here statements from two of the companies on this much-discussed pentode question.

—THE EDITOR.

By JASPER MARSH

Treasurer, Champion Radio Tube Company

The new type of pentode now being developed in this country is new. There is as much difference between the continent pentode and American pentode as there is between the UX-171A and the UX-250. The tube as it now stands is surely an engineering advance for the improvement of the art.

It is very easy to conceive a real power detector which will work directly into the loud speaker. It would make possible a real portable set, better radio sets for automotive uses, and cut the cost of operation considerably. Experimental work that has been done along these lines with the pentode tube proves that all these uses are quite feasible.

How the uniformity of pentodes will run is not known at the present time. If we care to take the English tube and compare its cost with their power tube similar to our UX-245, we will find them almost the same.

The single pentode has been used in the laboratory here and the hum from a standard filter such as used in the average receiver does not become any more noticeable than when using two 245-type tubes in push pull. As the E_p-I_p curve is almost perfectly flat a very small filter could be used in the plate supply. However, at the same time we must think of the ripple in the drop wire from which we obtain our bias. We do not believe any great trouble should be expected from this source, when using an average present-day filter.

As the load impedance for best operations is not taken as twice the tube impedance, as in the case of triodes, but $\frac{1}{3}$ or $\frac{1}{4}$ of the plate impedance, the cost of a very high-impedance transformer does not have to be considered and the output device would compare very favorably with that now used for a single UX-245.

In this connection there should also be given consideration to the matter of patent infringements on audio-frequency amplifiers using transformer coupling and push-pull output transformers. The pentode tube can be resistance coupled to the output of a power detector, such as the 224 tube, and hence greatly simplify the audio-frequency system.

Our general belief is that a tube that will deliver 3.5 watts of undistorted power output with a grid swing of 12 volts and a d.c. plate current consumption of 35 mA. at 250 volts, would be quite acceptable by



In southern Kansas it is becoming quite common to find motor buses equipped with a radio receiver for the entertainment of passengers. The picture above shows one of a fleet of similarly equipped vehicles.

many set manufacturers for their next model, and it is such people that should not get an unfavorable opinion or report on the tube.

By ERNEST KAUER

President, CeCo Manufacturing Co., Inc.

The response from the press, the trade, and the public over the announcement of the pentode has been most pleasing. The general character of this response evidences no idle curiosity but an expectation and appreciation of the progress in the development of radio science. The crystallization of modern thought to-day evidences an instant desire for constructive improvement.

Radio's increasing development is stimulating more and more thought of its future. The development of the a.c. pentode tube has emphasized in the public mind the fact that radio engineering is made up of two distinct schools—tube engineers and set engineers. The pentode tube has had the effect of establishing the

tube engineers on a status that they have not enjoyed heretofore. In the past, they have been the sort of silent craftsmen who labored in quiet, content to realize their new ideas and take satisfaction in accomplishment.

The entire radio world is indebted to the tube engineers; their researches have done much to make radio reception the glorious satisfaction that it is to-day. There seldom have been any startlingly quick developments in radio tube engineering. All the noteworthy results that are familiar to-day, have come over a period of years of study, application, and much costly effort.

The pentode tube has been in use in Europe for some years as an audio-frequency amplifier for battery-operated receivers. In the research laboratories of the CeCo Manufacturing Company our engineers have added many improvements to the original tube. They are the American pioneers and were the first to adopt the pentode to radio-frequency amplification and audio-frequency amplification for a.c. and d.c. operation. Tube engineers with the pentode and the screen-grid, and in many other instances, have invariably built up an idea which was ultimately used by set engineers. In the past, set engineers have not always been able to develop a receiving circuit which permits the utilization of a tube's full capacities.

The more efficient method seems to be either for tube engineers and set engineers to consult together in advance of a development, or for tube manufacturers to work out a circuit capable of using the full capacity of a new tube. In the latter case, the circuit should be made available to manufacturers of receiving sets without obligation. This last method is the one we have adopted in the case of the pentode. CeCo engineers are now offering to demonstrate to set manufacturers the possibilities of the pentode tubes. Our engineering staff and our engineering facilities are available

(Continued on page 353)

We Apologize

In an article entitled "Review" on page 251 in March, 1930, RADIO BROADCAST, we carried a report to the effect that the Balkeil Radio Company was in the hands of receivers. As this issue goes to press we learn that the report was incorrect—Balkeil was never in bankruptcy. This information was given in good faith as it came from a source which we considered reliable. We deeply regret the error and offer our apologies to the Balkeil Radio Company.

—THE EDITOR.

OF THE INDUSTRY

New Broadcasting Company

Two well-known Iowa stations, woc and who have requested the Radio Commission to approve the organization of a new company, the Central Broadcasting Company at Des Moines. This company is capitalized at \$500,000 and will absorb the interests of the Palmer School of Chiropractic, owners of woc, and of the Bankers Life Company, owners of who. It is planned by Dr. Frank Elliott, of woc, to synchronize the two stations by wire, later to erect a 50-kw. transmitter and reduce one of the stations to a regional status. Since 1928, woc and who have been dividing time on the 1000-kc. channel.

Money for Radio Administration

Late in January, Congress appropriated a total of \$106,000 for the Radio Commission, including salaries of the five commissioners at \$10,000 annually each, and for other authorized expenditures. This sum does not include the entire annual cost of radio administration which is nearly three times this amount.

Mexican Newspaper of the Air

Each night station XFX, Mexico City, broadcasts news of Mexico both in Spanish and English with 1000 watts on a wavelength of 329.6 meters. The broadcast starts at 11 P.M. Eastern Standard Time. This station uses the service of the Trems Agency, 43 Colon St., Mexico City, and claims it to be the only newspaper of the air in existence. Station XDA at 4 p.m., Eastern Standard Time, using 20 kw. on 21.85 meters, broadcasts Spanish and English news dispatches in continental code.

Personal Notes

John W. Million, former chief engineer of Bremer-Tully, is now with Utah Radio Products, Chicago, Ill., as research and field engineer.

Vernon W. Collamore, formerly general sales manager for Atwater Kent, is now manager of Radiola Division, RCA-Victor Company, Inc., succeeding E. A. Nicholas resigned.

E. A. Nicholas, former manager, Radiola Division, RCA-Victor Company, has resigned to form his own distributing organization. He will handle Radiolas and Radiotrons.

D. E. Replogle who recently joined the Jenkins Television Company as assistant to the president, has been made treasurer of that organization.

Fred W. Klingenschmidt, whose name is well known to old-timers in radio, has joined Army, Aceves & King, New York, as sales manager in charge of installations of the multi-coupler antenna system manufactured and sold by this firm.

Robert H. Stroud has been appointed convention manager, Atwater Kent Manufacturing Co. Mr. Stroud succeeds T. Wayne McDowell, who recently resigned.

G. A. Yanochowski has been elected president of the Kellogg Switchboard and Supply Company, succeeding the late W. L. Jacoby.

M. C. Rypinski, formerly with Brandes and Federal-Brands, is now manager of the radio department of Westinghouse at 150 Broadway, New York City.

Irving K. Fearn, formerly sales manager of The Ken-Rad Corporation, has joined the French Battery Company as assistant to the president.

H. L. Williams, formerly with Silver-Marshall, Inc., is now advertising manager of the Rola Company, Oakland, Calif., and Cleveland, Ohio.

Fred O. Lange, former Director of Safety, Ohio State Industrial Commission, recently assumed his duties as director of personnel at the Crosley Radio Corporation's plant.

Organization of the legal division of the Federal Radio Commission was completed for the first time

In the Tube Field

Ernest Kauer, president of CeCo, commenting on their development of an a.c. r.f. pentode says in refuting the claims of the RMA Engineering division: "To deny that CeCo's development is an advance in the radio art is as futile as was the attempt of automobile manufacturers who tried to delay the use of four-wheel brakes or balloon tires."

The Apex division of U. S. Radio & Television Corporation has placed an exclusive contract for its tube supply with the National Union Radio Corporation, according to a recent announcement. This company recently announced a seven-tube set priced complete with tubes at \$101.00.

Competitive lines in the radio tube field are being drawn in 1930 for the sharpest contest in the history of the industry, according to P. Huffard, president of National Carbon. "The tube industry is now in a similar position to that of the automobile industry in earlier years. From a position in which a good portion of the annual production came from a number of scattered manufacturers, that industry has evolved to a stage where the bulk of the production comes from a very few concerns. This is exactly the stage at which, in our opinion, the radio tube industry will have arrived by the end of 1930. The handwriting is definitely on the wall and should not be disregarded.

"The tube market offers one of the greatest replacement markets available to industry. It is destined to grow from year to year."

since the creation of the Commission with the appointment recently of two assistants to the general counsel. They are Duke M. Patrick, of Indianapolis, and Ben S. Fisher of Marshfield, Oregon.

Fred W. Piper is now sales manager of the Howard Radio Company.

Keith Henney, for five years director of RADIO BROADCAST's laboratory, is now on the staff of *Electronics* in New York City.

H. W. KaDell, formerly of National Carbon Company's Research Laboratory in Cleveland, has been transferred to New York City. His new position is sales engineer in the Eveready-Raytheon Tube Division of the general sales department.

Dr. Lee DeForest has recently been appointed consulting editor of the new publication *Electronics*.

Jesse Butcher, formerly with Doubleday, Doran & Company, Inc., and the New York Times, is now director of press relations for the Columbia Broadcasting System in New York.

R. T. Pierson has been appointed executive representative in contacts with radio, automotive, and electrical specialty industries by the General Cable Corporation, New York.

Harry Sadenwater, formerly engineer in charge of broadcasting stations of the General Electric Company, has recently joined the RCA-Victor Company, Inc., at Camden, New Jersey, as chief field engineer.

Lewis M. Clement, formerly chief engineer of Kolster Radio Corporation, has resigned and has joined M. S. Ripinski in the radio engineering division of the Westinghouse Electric & Manufacturing Company, 150 Broadway, New York City.

Donald McNicol has been appointed editor of *Radio Engineering*, succeeding M. L. Muhleman. (Other news items on pages 352 and 353)

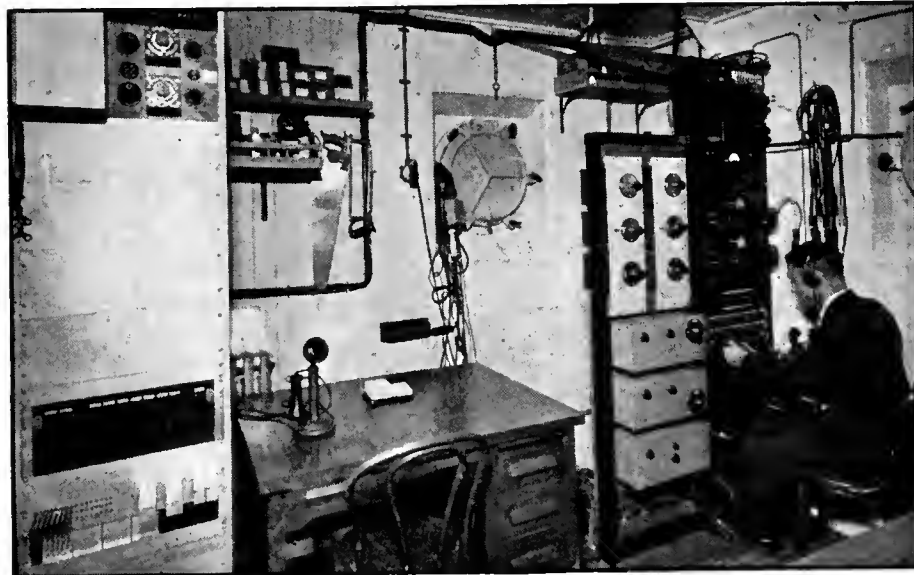

The inauguration of two-way ship-to-shore telephone service on the S. S. Leviathan makes it possible for any passenger to transact business or talk with friends by telephone while crossing the Atlantic. This picture shows the radio telephone equipment on the Leviathan. To the right is the receiving apparatus where voices from shore telephones are received by radio from the Deal (N. J.) station.

(Continued from page 351)

News of the Manufacturers

The Irving Trust Company of New York, as receivers for Sonora Products Company and Sonora Phonograph Company, was authorized by Federal Judge Coxe in New York early in February to continue the business of the companies for two months. If it is considered necessary, the receivers may apply for an extension. The purpose of the extension is to give the companies and creditors an opportunity to reorganize and to free the properties of the receivership.

Early in February, the receivership proceedings instituted against the DeForest Radio Company were dismissed by Chancellor V. M. Lewis of the Chancery Court at Paterson, N. J. Officials of the DeForest Company presented to the Court evidence of the solvent condition of the Company and statements which showed that during the 18 months of operation under the present officers a net profit of \$626,424.98 was realized. January 1930 showed a 24 per cent. increase over the previous month's business according to President Garside.

Soon after March 1, the Edison Lamp Works of General Electric, located at Harrison, N. J., will be transferred to Nela Park, Cleveland. The Harrison plant will be entirely taken over with the removal of the Lamp Works by the RCA Radiotron Company.

The Allwood, N. J., plant of Earl Radio has been completely shut down and is no longer operating.

The plant, good will, and assets of the Balkeit Radio Company, North Chicago, has been purchased by R. I. Mendles and R. L. Eglaston. They will operate under the name of the Balkeit Sales Company. Offices will be maintained at North Chicago and at 205 West Wacker Drive, Chicago. Mr. Mendles is president and Mr. Eglaston vice president and general manager of the new company. Mr. Eglaston was at one time general manager of the Karas Electric Company in Chicago.

Buckingham Radio Corporation, 440 West Superior St., Chicago, on December 27th was placed in the hands of a receiver in bankruptcy. Certain reorganization plans are under consideration but no definite announcement has yet been made.

Matters Legal

DeForest has filed suit against Pilot Radio & Tube Corporation, Brooklyn, manufacturers of radio parts, knockdown kits, and assembled radio receivers. DeForest seeks an injunction to restrain Pilot from an alleged infringement of DeForest patents Nos. 1507016 and 1507017 covering the use of regeneration in a radio receiving circuit. Says President Garside of DeForest: "There is a mistaken idea at large that the regenerative patent is public property, instead of the private and presumably valuable property of the DeForest Company."

Maine has a law primarily affecting the use of radiating receivers. It follows in full:

CHAPTER 215

An Act to Render Unlawful All Disturbances to the Reception of Radio Waves Used for Radiotelephony.

Sec. 1. It shall be unlawful to use within the state of Maine any radio receiving set which radiates radio waves, between two hundred and five hundred and fifty meters wavelength, thereby causing interference with the reception of any other radio receiving set unless said radiating set shall be rebuilt or re-designed to prevent said radiation.

Sec. 2. Whoever knowingly, maliciously, or wantonly by any means unreasonably disturbs the reception of radio waves used for radiotelephony, between two hundred and five hundred and fifty meters wavelength, shall be punished by a fine of not less than ten dollars and not more than fifty dollars to be recovered by complaint in any municipal or police court or before any trial justice.—Approved April 16, 1927.

A large chart tabulating the Federal Radio Act and amendments has been prepared by Nathan B. Williams and copies can be secured from him at the Insurance Building, Washington, D. C.

The Radio Corporation has requested that the Federal Trade Commission dismiss the complaint against it which charged that certain patent licenses granted by RCA to makers of receiving sets violated certain sections of the Clayton Act and the Federal Trade Commission Act. The license agreement was charged to require licensees to equip their sets initially only with RCA tubes. The Trade Commission has taken no action and no date has been set for a hearing.

Remote Control Patents

At the present time considerable activity is being shown by the radio industry in the direction of obtaining patents on automatic- and remote-tuning devices. Most of the inventions in this field have been made recently, and, therefore, a large percentage of the patent applications have not yet been acted upon. For the same reason, several manufacturers do not feel sure of their present positions and hesitate in making any statement on the subject for publication. However, because of the extreme interest in these developments a partial list of important manufacturers and their patent holdings has been compiled.

Name of Company	Remarks
All-American Mohawk Corp.	No patents filed
American Bosch Magneto Corp.	Do not own any patent
The Amrad Corporation	Do not own any patent
Atwater Kent Mfg. Co.	Patents applied for but not yet allowed
Carter Radio Co.	No patents issued yet. Several applications on file for some time
Colonial Radio Corp.	No patents at present time
Crosley Radio Corp.	Do not own or control any patents
Colin B. Kennedy Corp.	Do not own or control any patents
Kolster Radio Corp.	Patent No. 1552919; other patent applications including our basic case still pending in the Patent Office
Philadelphia Storage Battery Co.	No patents issued
Stromberg-Carlson Telephone Mfg. Co.	Patent Nos. 1655160; 1738262
Union Carbide & Carbon Research Labs., Inc.	Own no patents
Zenith Radio Corp.	Patent Nos. 1581145 (reissued 17002); 1638734; 1591417; 1701754; 1695919.

C.B.S. Negotiating for KMOX

The Columbia Broadcasting System is negotiating for the purchase of control of KMOX, St. Louis. In addition to ownership of its key station, WABC, it has acquired control of WBBM, Chicago, and WCCO, Minneapolis. The purchase of WCCO seems to be foreshadowed by its incorporation as a separate entity.



By the author of

"Principles of Radio Communication"

An independently written introduction to the subject of Radio

John H. Morecroft

Elements of Radio Communication

BY JOHN H. MORECROFT

"We can highly recommend 'Elements of Radio Communication' to those of our readers who want a book that will give them a strong, elementary grounding in radio and leave them with few questions to ask save those which may be born of a desire for more knowledge."

Boston Post Radio Section

\$3.00

JOHN WILEY & SONS, Inc.

440 Fourth Ave., New York

Please send me Morecroft's "Elements" for free examination. Within ten days after its receipt I will either return the book or send you \$3.00.

Name.....

Address.....

Firm.....RB 4-30

The World's Premier Custom-Built RADIO

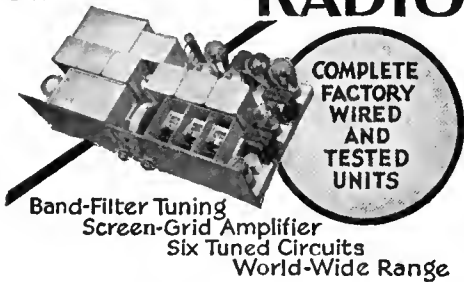

COMPLETE FACTORY WIRED AND TESTED UNITS

Band-Filter Tuning
Screen-Grid Amplifier
Six Tuned Circuits
World-Wide Range

NO radio produced in mass can even approximate the skilled perfection of the new Custom-Built "HIQ-30." Here is the newest, most efficient model by Hammarlund—the climax of five years of unequaled custom designing and famed throughout the world for power, selectivity and tone. A great opportunity for custom-set builders. Choice of magnificent cabinets and speakers.

A. C., D. C. and Battery Models. List, \$139.50 to \$1,175 complete, less tubes.

Mail Coupon for 48-page "HIQ-30" Manual



HAMMARLUND-ROBERTS, Inc.
424-138 W. 33rd St., N. Y.
Enclose 25c (stamps or coin) for "HIQ-30" Manual. RB 4

Name.....
Address.....

Recently Issued Patents

Electron-Emitting Material and Method of Making The Same. William Benjamin Gero, Bloomfield, N. J., assignor to Westinghouse Lamp Company. Filed June 29, 1928. No. 1,731,244.

Base for Radio Tubes. Clair J. Terrill, Dayton, Ohio, assignor to the Kurz-Kasch Company, Dayton, Ohio. Filed November 8, 1926. No. 1,731,832.

Apparatus for Recording and Reproducing Sound. Richard S. Arthur, New York, N. Y. Filed February 5, 1926. No. 1,732,036.

Sound-Regenerating Device. Wehrli D. Pack and Joseph M. S. King, Salt Lake City, Utah, assignors to Utah Radio Products Company, Inc. Filed July 29, 1926. No. 1,735,873.

Cross Screen Picture Receiving System. Richard Howland Ranger, Newark, N. J., assignor to Radio Corporation of America. Filed January 9, 1928. No. 1,736,219.

Means for and Method of Volume Control of Transmission. George Crisson, East Orange, N. J., assignor to American Telephone and Telegraph Co. Filed Sept. 12, 1924. No. 1,737,830.

Arrangement to Protect Capacitive Loud Speakers Against Puncture. Manfred von Ardenne, Berlin, Germany. Filed April 28, 1928, and in Germany April 28, 1927. No. 1,737,872.

Diaphragm Especially for Sound Receiving and Radiating Apparatus. Heinrich Hecht, Kiel, Germany, assignor to Signal Gesellschaft mit beschränkter Haftung, a Firm of Kiel, Germany. Filed February 9, 1925, and in Germany February 20, 1924. No. 1,737,883.

Volume-Control System. Lee G. Bostwick, East Orange, N. J., assignor to American Telephone and Telegraph Co. Filed March 6, 1925. No. 1,737,992.

Means For and Method of Volume Control of Transmission. Estill I. Green, East Orange, N. J., assignor to American Telephone and Telegraph Co. Filed August 5, 1926. No. 1,738,000.

Television. Herbert E. Ives, Montclair, N. J., assignor to Bell Telephone Laboratories, Inc., New York, N. Y. Filed May 20, 1926. No. 1,738,007.

Piezo-Electric Crystal Oscillator. Alfred Crossley, Washington, D. C., assignor to Wired Radio, Inc., New York, N. Y. Filed May 28, 1926. No. 1,738,041.

Method and Apparatus for Remotely Controlling Radio Receiving Systems. Winfred T. Powell, Rochester, N. Y., assignor to The Stromberg-Carlson Telephone Manufacturing Co., Rochester, N. Y. Filed October 15, 1925.

Single-Side-Band Carrier System. Estill I. Green, East Orange, N. J., assignor to American Telephone and Telegraph Company. Filed September 20, 1926. No. 1,744,044.

Combined Recorder and Reproducer. Arthur C. Keller, New York, N. Y., assignor to Bell Telephone Laboratories, Inc., New York, N. Y. Filed February 10, 1928. No. 1,744,047.

Modulation System. Robert L. Davis, Wilkesburg, Pa., assignor to Westinghouse Electric and Manufacturing Co., Filed August 6, 1925. No. 1,744,214.

Audio- and High-Frequency Amplifying Tube. Siegmund Loewe, Berlin, Germany, assignor to Radio Corporation of America. Filed October 18, 1925, and in Germany November 13, 1924. No. 1,744,653.

Frequency Changer for Short Waves. Mendel Osnos and Richard Kummich, Berlin, Germany, assignor to Gesellschaft für Drahtlose Telegraphie m.B.H., Berlin, Germany. Filed August 14, 1925, and in Germany Aug. 16, 1924. No. 1,744,668.

Radio Transmitting System. Georg von Arco, Berlin, Germany, assignor to Gesellschaft für Drahtlose Telegraphie m.B.H., Hüllesches, Berlin, Germany. Filed November 23, 1925, and in Germany December 6, 1924. No. 1,744,711.

Patent Suits

M. C. Hopkins, Acoustic device, filed Sept. 26, 1929, D.C., E.D., N.Y., Doc. 4450, Lektophone Corp. v. Colonial Radio Corp. No. 1,271,529.

L. A. Hazeltine, Method and means for neutralizing capacity coupling in audions, filed July 18, 1929, D.C., E.D., N.Y., Doc. 4323, Hazeltine Corp. v. National Carbon Co., Inc., et al. Same, filed July 31, 1929, D.C. E.D. N.Y., Doc. 4362, Hazeltine Corp. v. A. I. Namm & Son, Inc., Doc. 4363, Hazeltine Corp. v. Abraham & Strauss, Inc. Same, filed Aug. 3, 1929, D.C. E.D. N.Y., Doc. 4369, Hazeltine Corp. v. E. A. Wildermuth. Same, filed Aug. 9, 1929, D.C. E.D. N.Y., Doc. 4371, Hazeltine Corp. v. Brooklyn Radio Service Corp., Doc. 4372, Hazeltine Corp. v. Colonial Radio Sales Co., Inc. No. 1,533,588.

L. A. Hazeltine, Wave Signaling system, filed Aug. 13, 1929, D.C. E.D. N.Y., Doc. 4387, Hazeltine Corp. v. E. A. Wildermuth. No. 1,648,808.

A. J. Weiss, Electrical Condenser, filed Sept. 30, 1929, D.C., E.D. N.Y., Doc. 4452, Dubilier Condenser Corp. v. Aerovox Wireless Corp.

Tube Makers Defend The Pentode

(Continued from page 350)

for coöperation on circuit problems. This is a service we owe set manufacturers, and we are eager to render all the aid we can.

The Pentode represents a definite advance in radio. It cancels the necessity of multi-tube receivers. It permits building more simplicity into radio manufacture; makes simpler and less costly receiver operation and maintenance. It should reduce manufacturing and material costs, and costs to the radio public.

Tests in our own laboratory and in laboratories owned by others, show that the CeCo a.c. pentode performs up to all the claims we make for it. The results of these tests also prove that the pentode tube does make possible four-tube sets, or three-tube sets not counting the rectifier, and that these sets will operate as satisfactorily as the many-tube sets of to-day. In our own laboratory, we are doing considerable research work to develop new receivers for commercial use outside of radio. I venture to predict that in less than a dozen years the tube division of the radio industry will be the dominant factor in radio's march of progress.

The CeCo Manufacturing Company has had some criticism by set manufacturers because of what they call a premature announcement of the pentode tube, but the manufacturer who does not like change is in for an uncomfortable time. Nothing can stop the changes that are coming.

The progressive manufacturer is in for one of the most profitable and interesting periods in our history. It is sometimes remarked that business needs to be stabilized. When a man says that he means that he would like to get his business fixed so that he would not have to worry any more. If he wants stability in business, let him go to the Oriental countries; they have had their business stabilized over

there for hundreds of years, but where are they to-day? Some people say ours will be a great country when it is finished. When this country is finished, its period of greatness will be over, for at that time the life will have gone out of it.

We may be thankful it will never be finished. Our industry will always need and want new ideas.

Good News for Servicemen

After considerable study and discussion, a plan has at last been worked out whereby the Radio Service Managers Association is enabled to conduct examinations of out-of-town servicemen by mail.

The plan as worked out for the out-of-town serviceman, requires that he first supply the R.S.M.A. with the name of his employer, or if unemployed, with the name of a notary public in his town to whom the examination may be mailed. Having done this the applicant must then arrange to take his examination in the presence of this party and have him fill out a form of affidavit to certify that all of the requirements and conditions under which the examination was sent have been complied with.

All papers must be mailed to the office of the R.S.M.A. for correction along with the original questions and must be accompanied by an application for membership and dues. Upon correction the applicant will be advised as to his mark and in all cases where a satisfactory mark has been made, certification cards will be issued. Those failing to make a satisfactory grade will be obliged to wait a period of thirty days before another examination may be taken.

Any serviceman wishing to secure an R.S.M.A. certification should address the Radio Service Managers Association at 324 West 42nd Street, New York City, designating the party to whom the examination papers are to be sent.

To
Think of

Transformers

is to
Think of

THORDARSON

TRANSFORMER
SPECIALISTS
Since 1895 . . .

Microphone Transformers

Line to Tube, Tube to Line,

Line to Line

Mixing Transformers

● Coupling Reactors ●

Filter Chokes

Audio Transformers ●

Impedance Matching

Transformers ● Power

Compacts

Speaker Coupling Trans-

formers

Complete Amplifiers . .

**THORDARSON
ELECTRIC ● ●
MANUFACTURING
COMPANY ● ●**

**Huron, Kingsbury and
Larrabee Streets . . .
Chicago, Illinois, U. S. A.**

IN THE RADIO MARKETPLACE

News, Useful Data, and Information on the Offerings of the Manufacturer

Majestic Receivers

GAIGSBY-GRAUNOW COMPANY: The Majestic line of radio receivers now includes the following models: Model 90 at \$95.00 less tubes or \$116.50 completely equipped with Majestic tubes; Model 91 at \$116.00 and \$137.50 with tubes;



Model 92 and 93 at \$146.00 and \$167.00 with tubes; Model 102 radio-phonograph at \$184.00 and \$205.50 with tubes, and Model 103 at \$203.50 and \$225.00 with tubes.

Cornell Paper Condensers

CORNELL ELECTRIC MANUFACTURING COMPANY: This company manufactures a complete line of small and large by-pass condensers for use in radio receivers. Based on 0.0005-inch paper linen the Cornell specifications are as follows:

Thickness: Capacitor tissue must caliper as close to specified thickness as possible. In no case should individual readings vary more than 5 per cent. over or under the thickness specified in the order.

Porosity: Capacitor tissue must not measure less than 105 seconds in air resistance.

Uniformity: The tissue is to be free from wrinkles, cockles, creases, slugs, and to be practically free from pinholes.

Width of tissue: The width of the tissue must be within $\frac{1}{4}$ inches of the specified width up to a maximum width of 4 inches. Between 4 inches and 8 inches the variation shall not be greater than $\frac{1}{8}$ inch plus or minus.

Alkalinity: No more than one gram of paper shall require more than 0.30 milligrams of sulphuric acid for complete neutralization.

Acidity: The water extract of one gram of paper shall not require more than 0.10 milligrams of sodium hydroxide for complete neutralization.

SAF-3 Mixer

SIMPLIMUS, INC.: The SAF-3 Mixer is designed for use in a theater "sound-movie" installation and its function is to control the quality of

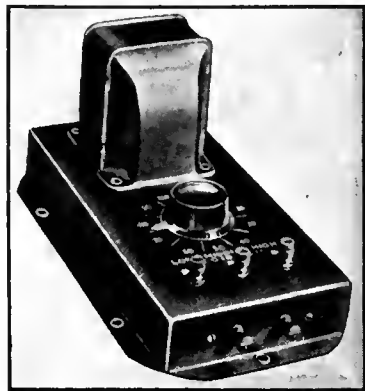

reproduction. The unit is connected between the pick-up unit and the amplifier. On the instrument are three switches marked "Low Register," "Middle Register," and "High Register," and a knob marked "Compensator." The instrument functions to eliminate to an extent determined by the setting of the compensator the band of frequencies to which the switch is turned, i.e., if the switch is placed on "Low Register" the low frequencies are suppressed. If connected to the "High Register" position the high frequencies are suppressed. In this way the operator can reduce that part of the audio-frequency range which normally receives too much amplification due either to poorly designed sound equipment or to poor theater acoustics. The instrument is manufactured to the specifications of Simplimus by the S A F Electrical Engineering Company.

Antenna Equipment

M. M. FLERON AND SON, INC.: Lightning arrestors, complete antenna kits, light-socket antennas, ground clamps, loud speaker extension cords, insulators, lead-in strip, porcelain lead-in bushings, and other similar items are manufactured by this company.

Supreme Tube Tester

SUPREME INSTRUMENTS COMPANY: The Model 50 Tube Tester is designed especially for use in testing laboratories, high-grade service laboratories, and by large dealers and distributors. The unit is self contained, drawing all its power from the 60-cycle, 110-volt a.c. line. To compensate line-voltage variations the units contains a constant-voltage transformer manufactured under a license from the Ward Leonard Electric Company. The instrument will test all types of tubes, a.c. or d.c., three-element or four-element. An indication of mu and Gm are obtained by a direct-reading on the dial. By pressing buttons the tube can be tested for gas and emission. The unit sells at a dealer's net



price of \$98.50. A much simpler tube checker, the Model 17, is designed to give simple but effective tests on tubes. The net price is \$19.50. The Model 10 Ohmmeter may be used to determine the value of resistors and is also useful in checking apparatus and tracing circuits. Net price: \$17.50.

New Photo-Electric Cell

JENKINS TELEVISION CORPORATION: An extremely sensitive hydride type photo-electric cell for television work has been developed. It is now in production and available to the public through the sales department of the De Forest Radio Company.

Precision Resistance Amplifier

INTERNATIONAL RESISTANCE COMPANY: Joseph Morgan, of the Engineering Department of this company, has developed a resistance-coupled amplifier which gives uniform frequency response within 1 db from 0 cycles up to 20,000 cycles per second. Another type of amplifier has been designed with a gain of approximately 55 db, a power output of about 4.5 watts, and uniform response over the frequency range of 30 to 10,000 cycles. Complete engineering bulletins describing these amplifiers can be obtained from the company.

New Bosch Models

AMERICAN BOSCH MAGNETO CORP.: The two newest Bosch consoles using the Bosch screen-grid chassis and electrodynamic loud speaker are the model 11 listing at \$198.50 and the Model 16 listing at the same price.

New Silver Receivers

SILVER MARSHALL, INC.: Six models of Silver Radio are now available. The three newest models are the Model 60B Lowboy, \$145.00, less tubes, or \$169.50 complete; Model 75B Concert Grand, \$158.00 less tubes, or \$182.50



complete; and Model 95B Highboy, \$145.00 less tubes, or \$169.50 complete. These latest models use a screen-grid circuit with a screen-grid detector. Two of the four tuned circuits are placed ahead of the first tube so as to prevent cross-talk. The chassis is cadmium plated.

New CeCo Tube

CECO MANUFACTURING COMPANY: The new CeCo 227 replacing the old type N-27 has the following features:

Two mica spacing members, the upper one much larger than usual.

A grid built around two supporting bars instead of the usual single bar.

Short cathode.

Shortened distance from glass stem to electrode.

Longer glass stem.

The larger upper mica separator holds both cathode and grid in positions concentric to the plate and yet when the tube heats it permits expansion without strain to cause warping. The double supported grid helps to maintain tube uniformity. The tube is not of the quick-heating type, although the new tube does reach an operating temperature quicker than did the old tube. In this connection CeCo engineers stated, "Actually the cathode reaches its operating temperature in less time than did the cathode of the N-27. CeCo will release a quick-heating tube when and only when a way is found to combine quick heating with satisfactory operating life."

Turntable Equipment

ELECTRICAL RESEARCH PRODUCTS, INC.: A number of broadcasting stations have purchased turntable equipment from this company to permit the use of special or ordinary phono-



graph records for broadcast programs. The turntables are available in either single or double units operating at either 33 $\frac{1}{2}$ or 78 r.p.m. At the present time the equipment is in use at approximately twenty broadcasting stations. The equipment is not sold outright but is loaned to the station under a three-year license agreement which includes complete servicing by ERPI. The following stations have this equipment at the present time. In the following list



"Double 33 $\frac{1}{2}$ " means two turntables operating at 33 $\frac{1}{2}$ r.p.m. "Double 78" means two turntables operating at 78 r.p.m.

WTMJ	Double 33 $\frac{1}{2}$	Double 78
KMOX	Double 33 $\frac{1}{2}$	
WOC	Double 33 $\frac{1}{2}$	Double 78
WOAX	Single 33 $\frac{1}{2}$	
WCAO	Single 33 $\frac{1}{2}$	Double 78
WSM	Double 33 $\frac{1}{2}$	Double 78
KPBC	Single 33 $\frac{1}{2}$	Double 78
KFUM	Single 33 $\frac{1}{2}$	Double 78
KLZ	Double 33 $\frac{1}{2}$	Double 78
WBT	Single 33 $\frac{1}{2}$	
WTAM	Double 33 $\frac{1}{2}$	Double 78
KFEL	Single 33 $\frac{1}{2}$	
KFH	Double 33 $\frac{1}{2}$	Double 78
KJAS	Double 33 $\frac{1}{2}$	Double 78
KWCR		Double 78
WHK	Double 33 $\frac{1}{2}$	
KHQ	Double 33 $\frac{1}{2}$	
WMT		Double 78
WLAW	Double 33 $\frac{1}{2}$	Double 78
WKBH	Double 33 $\frac{1}{2}$	Double 78

Electrical Meters

FERRANTI, INC.: This company announces a new line of microammeters, milliammeters, and voltmeters for use in measuring alternating currents at all frequencies from 20 to 6000 cycles. The instruments use dry rectifiers in conjunction with d.c. indicating meters. There are two types available, one having a resistance of 667 ohms per volt and drawing 1.5 mA. at full-scale deflection, and the other type having a resistance of 133 ohms per volt and drawing 7.5 mA. for full-scale deflection. The microammeter is made in only one size with a maximum reading of 750 microamperes. The milliammeters are available in ranges from 1.5 up to 500 mA., ammeters in ranges from 1 to 5 amperes, and voltmeters in ranges from 1 to 250 volts. Practically all of the instruments are priced at \$35.00. The instruments can replace the vacuum-tube voltmeter in many measurements and are ideal for determining the frequency performance of audio-frequency amplifying systems.

Gulbransen Model 9950

GULBRANSEN COMPANY: The Model 9950 is a nine-tube receiver using screen-grid tubes, power detector, and push-pull audio-frequency amplification. The list price is \$99.50.



Wire-Wound Resistors

INTERNATIONAL RESISTANCE COMPANY: This company announces wire-wound, non-inductive resistors, wound to an accuracy of approximately one-half of one per cent. Each unit consists of an Isolantite tube with prominent fins to form a series of miniature bobbins which hold the winding. The winding is arranged in opposite directions in adjacent bobbins for the non-inductive effect. The tubing and winding are treated with bakelite varnish, while the end caps are molded rather than soldered to the ends, providing the best possible contact with the winding. A special grade of resistance wire is employed, with improved insulation so as to withstand much higher voltages without breakdown than the wire heretofore employed in layer-wound resistors. The Durham wire-wound units are available in resistance values from 500 ohms to several megohms.

Oxford Loud Speakers

OXFORD RADIO CORPORATION: Several new models have been added to this company's line of electrodynamic loud speakers. Some of the loud speakers are equipped with a universal coupling transformer arranged with tapped connections so that the loud speakers may be used with various types of tubes. Transformers to meet special conditions are furnished on request.

Transmitting Condensers

NATIONAL COMPANY, INC.: The Type TNU National transmitting condensers have ratings of 5000 and 7500 volts. The end plates are cast aluminum and all rotor and stator plates have rounded and polished edges. By special arrangement with the Radio Corporation of

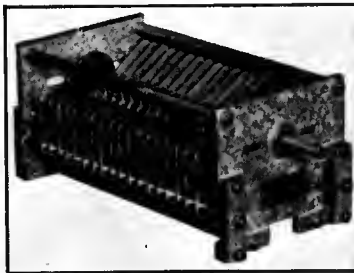

America, Micalex insulation is employed. Type R-39 insulation, a special development of the Radio Frequency Laboratories, can be supplied if desired in place of Micalex. The condensers are of variable capacities from 0.0005 to 0.0005 mfd. Prices range from \$47.50 down to \$41.00.

Booklets and Catalogs

FERRANTI, INC.: The new Ferranti catalog gives complete details of various types of Ferranti power amplifiers, audio-frequency transformers, pocket test sets, d.c. tube testers, fixed condensers, wire-wound resistors, d.c. voltmeters, ammeters, and all types of a.c. meters.

INTERNATIONAL RESISTANCE COMPANY: A booklet entitled "Fixed Resistor Replacement Problems" available to any interested persons gives some data on the importance of fixed resistor replacement. The a.c. receiver caused a very marked increase in the number of resistors used in a set and proper consideration in their replacement is of obvious importance.

DEFORREST RADIO COMPANY: A comprehensive catalog covering the extensive line of DeForest transmitting and power-rectifying audions had just been issued by the De Forest Radio Company, Passaic, N. J. The De Forest line now includes thirteen transmitting and rectifying audions, for use as oscillators, rectifiers, radio- and audio-frequency amplifiers, and modulators. These tubes range in power from 15 to 5000 watts. Among the types cataloged are mercury-vapor rectifiers, screen-grid transmitters, and water-cooled tubes, thereby covering every standard function in transmitting and auditorium amplification. Aside from the standard broadcast reception audions, the DeForest products also include the DeForest neon lamp, and photo-electric cells manufactured to exact specifications. The catalog is available to anyone on request.

Home "Talkie" Outfit

STEVENS MANUFACTURING CORPORATION: This company has designed a small outfit incorporating an electric turntable, electric pick-up, a.f. amplifier, and electrodynamic loud speaker together with the necessary power supply for the entire assembly. The equipment, which has been designed for use in connection with home-movie apparatus, is now in production and available to the public.

Loftin-White Kit

ELECTRAD, INC.: A complete kit for the construction of a Loftin-White amplifier is available from Electrad. The kit designated as A-245 contains all parts except tubes. The amplifier utilizes one 224-type screen-grid tube, one 245-type power tube, and one 280-type rectifier. The amplifier is designed primarily for use in



connection with electric pick-up units but with the addition of a conventional coupling device it can be connected to various radio tuners. The list price is \$35.00 less tubes.

Radiola Price Reductions

RCA-VICTOR COMPANY, INC.: The Radiola Division of the RCA-Victor Company, Inc., has announced a change in the list price of three of its models. Radiola 47, a screen-grid radio-phonograph combination, has been reduced from \$275.00 to \$195.00; Radiola 64, a superheterodyne receiver, has been reduced from \$550.00 to \$193.50; and Radiola 66, console superheterodyne receiver, has been reduced from \$225.00 to \$175.00, the new prices, which are quoted less tubes became effective as of January 30, 1930.

New Variable Condensers

ROCHESTER TOOL AND GAUGE CORPORATION: Condensers manufactured by this company are housed in complete shielding with tubing adjustment screws for the compensators. A separate compensator is associated with each unit of the gang and gives a variation of approximately 40 mmfd. The minimum capacity of the 0.0005-mfd. condenser is 30 mmfd. and 24 mmfd. for the 0.00035-mfd size. The contour of the rotor is such that 40 per cent. gives 1 kc. separation and the other 60 per cent. a 2-meter separation. The shaft is $\frac{1}{8}$ inch diameter. Flexible contact leads are supplied. The plates are hard sheet aluminum 0.32 inch thick.

Fada Model 40

F. A. D. ANDREA, INC.: The Model 40 uses tuned impedance coupling with 224-type screen-grid tubes followed by a 227-type power detector, a 227-type a.f. amplifier, and two 245-type power tubes. Features of the receiver are automatic station finder and indicator, special tone adjuster, and a Fada super-electrodynamic loud speaker. The Model 40 has been tested and approved by the Underwriters Laboratories of the National Board of Fire Insurance Laboratories.



Measuring Resistance

ONE OF THE simplest methods of measuring resistances is by the use of a d.c. voltmeter connected in series with the resistor to be measured and across a known d.c. voltage. The circuit is shown on this sheet.

The procedure is to measure the d.c. voltage first with the voltmeter. The resistor to be measured is then connected in series with the meter and the reading of the meter noted. With these data the value of the resistor may be obtained from the formula—

$$R_o = \frac{E_o - E_r}{E_r} \times R_m$$

where R_o is the resistance in ohms;

E_r is the voltage read on the voltmeter with the resistance connected in series with the voltmeter;

E_o is the voltage of the source, i.e., that voltage indicated by the meter when it is connected directly across A-B;

R_m is the resistance of the meter.

Therefore, the only data needed to measure resistances by this method is the resistance of the voltmeter. This information may be marked on the meter or, if not, it can be obtained from the manufacturer. In the following paragraphs are a few examples worked out by this method.

Example: A 250-volt meter with a resistance of 1000 ohms per volt is to be used to measure the

value of an unknown resistor. The voltmeter is connected directly across three B batteries and the potential is found to be 140 volts. The unknown resistor is then connected in series with the meter and the meter reads 25 volts. What is the value in ohms of the resistance?

Since the voltmeter has a resistance of 1000 ohms per volt, the total resistance, R_m , is 1000 times 250 or 250,000 ohms. E_o as measured is 140 volts. E_r is 25 volts. Therefore—

$$R_o = \frac{140 - 25}{25} \times 250,000$$

$R_o = 1,150,000$ ohms as the value of the unknown resistor.

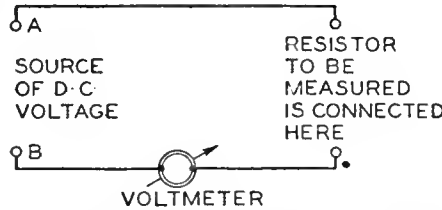

Three Types of Distortion

SEVERAL DIFFERENT types of distortion can be produced in the power tube. Distortion may result from (a) volume distortion, (b) frequency distortion, and (c) harmonic distortion.

Volume distortion: The ratio between the output obtained from a tube and the a.c. input voltage to its grid should be constant up to the point where the tube begins to overload. If the ratio between output voltage and input voltage increases as the input voltage increases the strong signals are amplified more than weak signals; if, conversely, the ratio decreases as the input voltage is increased, strong signals are amplified less than weak signals. In power tubes this type of distortion is slight, the power output per volt input squared being constant up to the point at which the tube overloads.

Frequency distortion: A tube and its associated circuits should give uniform amplification to all frequencies over the audio-frequency band if it is desired to transmit. If the amplification varies with different input frequencies certain notes are amplified more or less than others. Over the audio-frequency band little distortion of this type is

produced by the tube itself, although frequency distortion may be introduced by the apparatus associated with the power tube, such as the input or output transformer and loud speaker.

Harmonic distortion: If a pure sine wave at some frequency is applied to the grid of a tube and in the output of the tube the same and other frequencies appear, then harmonic distortion is occurring. All power amplifiers produce a certain amount of this type of distortion, its extent depending upon the characteristics of the tube itself and the circuits out of and into which it works. The amount of second-harmonic distortion is used as a basis for rating the maximum undistorted output from a tube. If an ordinary three-element tube is working into a load resistance equal to twice its own plate resistance, the second-harmonic current is about 5 per cent. at a point just before the tube begins to overload. This amount of distortion is considered small enough to be negligible. A tube may, of course, generate other frequencies besides the second harmonic and, in fact, when a tube is somewhat overloaded it produces large amounts of second-, third-, and fifth-harmonic distortion.

Detection Characteristics

DETECTION characteristics, showing the relation between the d.c. plate current and r.f. input to a detector are very useful in determining the best point at which to operate a tube as a detector. Such a group of curves are shown on this sheet, being taken from an article "Detection at High Signal Voltages" by Stuart Ballantine published in the *Proceedings of the Institute of Radio Engineers*.

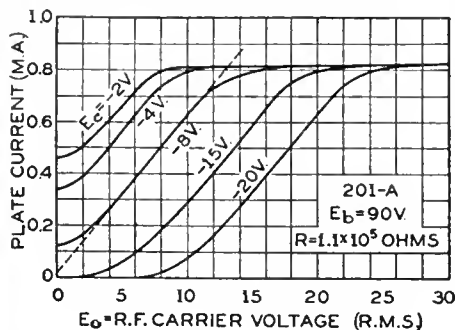

The curves on this sheet are for a 201A-type tube operated with a resistance load in the plate circuit from a battery potential of 90 volts. Five curves are shown for grid biases from -2 to -20 volts. These curves were made by measuring the plate current as the r.f. input voltage was gradually increased from 0 up to 30 volts. The plate currents obtained with the various input voltages were then plotted and the series of curves shown on this sheet was obtained.

Minimum distortion will be obtained when the r.m.s. value of the carrier input is such as to bring the operating point of the tube at about the center of the straight portions of these curves. When this is done a linear characteristic is obtained and minimum distortion results. For example, the best operating point on the curve corresponding to the bias of minus 3 volts is with a carrier input of about 7 or 8 volts r.m.s. If the carrier input is greater or less than this figure some distortion will result especially at high values of modulation. Since many sets have the volume control in the r.f. amplifier so that the r.f. input to the detector varies depending upon the volume control setting an effect such as described above would take place. This can be prevented, however, by obtaining the bias of the tube from the plate current so that as the r.f. input changes the detector will tend always to operate on the proper characteristic.

BOOK REVIEWS

HOW TO PASS THE U. S. GOVERNMENT RADIO LICENSE EXAMINATIONS by Rudolph L. Duncan and Charles E. Drew. Published by John Wiley and Sons, Inc., N. Y. C., 1929. Paper covers, 9-3/4" by 6-5/8", 169 pages, illustrated. Price: \$2.00.

This book is not offered as a complete textbook on radio operating or radio theory; its chief purpose is to aid the more or less experienced radio man who contemplates taking the government radio license examination. The authors point out in the foreword: "There are many experienced radio men who fail to pass the government examination because they are not familiar with commercial apparatus and commercial operating procedure. Then there are others who are more or less handicapped because they lack expression; they know the subject from the practical viewpoint but they are unable to put their knowledge into words. The real purpose of this book is to show how radio questions and examinations should be answered."

The text and illustrations of this volume consist chiefly of 259 typical questions (with correct answers) such as might be found on U. S. Government radio examinations. These questions include all phases or radio operating and theory with which the commercial operator is required to be familiar, including; commercial and broadcast transmitters, radio receiving apparatus, motors and generators, storage batteries and auxiliary apparatus, radio laws and regulations, etc. In addition to questions and answers the book contains a chapter giving regulations governing the issuance of radio operators' licenses and an Appendix which contains important radio formulas, frequency vs wavelength tables, standard radio symbols, the "Q" signals, the International Morse Code, and other important data.

RADIO TRAFFIC MANUAL AND OPERATING REGULATIONS by Rudolph L. Duncan and Charles E. Drew. Published by John Wiley and Sons, Inc., New York City, 1929. Paper covers, 9" by 6", 187 pages, illustrated. Price: \$2.00.

This volume by the authors of *Radio Telegraphy and Telephony* and *How to Pass the U. S. Government Radio License Examinations* will be helpful to amateurs, Army and Navy radio operators, and to others who wish to enter the field of radio operating. It describes fully government and commercial traffic rules and regulations which govern the manner in which radio communications shall be handled and gives other instructions which should be followed by the operator as closely as conditions permit. It is not only useful to the beginner who is anxious to learn commercial technique but is also valuable as a reference book on the commercial operator's operating table. The text includes the U. S. Radio Act of 1912, The Ship Act of July 3, 1912, and a complete index.

WIRING DIAGRAMS

are now available to supplement the wiring diagrams in Riders "Trouble Shooter's Manual." Supplementary Package No. 1 contains 115 wiring diagrams of radio receivers manufactured during 1929-1930. Many of the latest screen grid receivers are included. These schematics are black on white, 8 x 11 inches, punched for standard three-hole binding.

115 wiring diagrams for \$2.50

RADIO TREATISE CO.

1440 Broadway

New York City

CHARACTERISTICS OF TELEVISION SIGNALS

(Continued from page 319)

is only necessary to employ synchronous motors of the same speed for rotating both mechanisms. Temporarily, while the television audience consists mainly of amateurs interested in results with the minimum expenditure, this method is ideal. However, as the service areas of visual broadcasting stations are increased it will become necessary to employ more intricate means of synchronizing.

A synchronizing tone, let us say 720 cycles (which is the scanning frequency of a 48-line picture at 15 pictures per second), is transmitted to the receiving point.

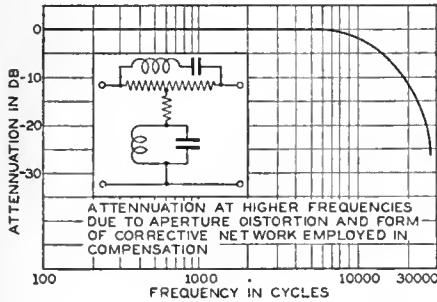

Fig. 11

This may be supplied by a photo-electric cell operated by a light ray passing through the scanning apertures or by a small alternator operated from the same motor as the scanning mechanism. This 720-cycle signal may be transmitted to the receiving point as a modulation of a second carrier, or as a modulation of a 30-kc. wave which in turn modulates the same carrier as the picture signal, or it may be intermixed with the picture signal in the correct proportion. In the first two cases it would be necessary to employ two receivers or a special receiving system of the "double-modulation" type. The third case merely involves a filter circuit arranged so as to remove the 720-cycle component from the last stage of the picture amplifier. The synchronizing signal is employed separately and applied to a 720-cycle motor operating the scanning mechanism. In order to reduce the power required in the synchronizing motor, two sources of power are employed. A simple d.c. or a.c. motor supplies enough power to neutralize the friction and windage losses and starts the scanning mechanism in rotation. The 720-

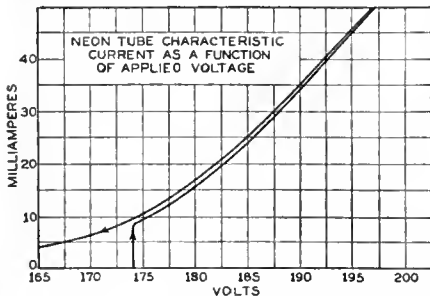

Fig. 12

cycle synchronous motor serves merely to maintain rotation and synchronous speed. In starting up, the power input to the first motor is raised so as to pass through the required speed, and then the motion is retarded until interlocking occurs.

Errors in Adjustment

Certain aspects of the image indicate errors in adjustment which may be readily corrected if they are borne in mind. Thus an inverted picture tells us that the scan-

(Continued on page 358)

CASH IN On a New Demand

Every city and town offers opportunities for the sale and installation of sound equipment, and local radio dealers are the logical men to cash in on this demand. Wright-De Coster Reproducers and horns are meeting with tremendous success wherever installed—for either indoor or outdoor use.

WRIGHT-DE COSTER REPRODUCER

There is a most efficient type of equipment for every purpose ranging from a tremendous battery for outdoor or arena use to single units for theatrical use and smaller sizes for home radio.

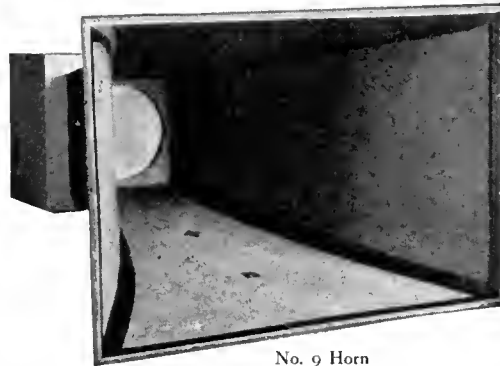

No. 9 Horn



"The Speaker of the Year"

Write for Complete Information and Name of Nearest Sales Office

Wright-De Coster, Inc. 2213 University Ave., St. Paul, Minn.

Export Dept.—M. Simons & Son, 220 Broadway, New York City
Cable Address, Simontrice, New York

A Radio Parts Guide

THE NEW YAXLEY Catalog



Send for it today for complete listings of Radio Convenience Outlets, Connector Plugs, Rheostats, Fixed and Grid Resistances, Jacks, Jack Switches, Phone Plugs, etc.

YAXLEY MFG. CO.

Dept. B, 1528W Adams St., Chicago, Ill.

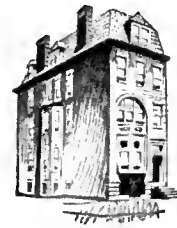

C. R. I.

Trains men for all branches of radio work.

Including:

COMMERCIAL RADIO RADIO SERVICE

RADIO BROADCAST NAVIGATION
RADIO MATHEMATICS LABORATORY
VITAPHONE-MOVIETONE

Dormitory—Laboratory—Workshop

Literature on Request

COMMERCIAL RADIO INSTITUTE
38 W. BIDDLE ST. FOUNDED 1920 BALTIMORE, MD.



Fulco RADIO COVERS

"FULCO" covers are used by those dealers who realize the importance of making deliveries in perfect condition — without scratches or mars. For they know that complaints mean dissatisfied customers and loss of business.

"FULCO" covers are a real service feature that helps sales and holds trade. Substantially constructed, heavily padded, box-shaped, providing perfect protection. Give us the dimensions of radios handled and let us quote special prices on your individual needs. Write our nearest house.

Fulton Bag & Cotton Mills

Manufacturers Since 1870
ATLANTA · NEW ORLEANS · DALLAS · ST. LOUIS
MINNEAPOLIS · BROOKLYN · KAN. CITY, KAN.

ON AND OFF
IN A JIFFY

Calculating Detector Output

IN "LABORATORY SHEET" No. 339 is given the "transrectification" diagram of a 201A-type tube operated at a battery potential of 90 volts with a 110,000-ohm load in its plate circuit. This diagram shows the relation between d.c. plate current and r.f. input voltage with various values of C bias. The method of obtaining the curve and a brief explanation of what it means will be found on the same sheet. In the following notes we explain how it is possible from this simple diagram to determine the audio-frequency output voltage from a detector with a given r.f. input signal.

To explain how this is done let us take for example the center curve corresponding to a grid bias of minus 8 volts. This particular curve then shows the plate current obtained with various r.f. voltages applied to the input. With zero r.f. input the plate current is approximately 0.12 milliamperes, and, as the r.f. input is increased, the plate current gradually rises and then flattens out. It reaches a maximum of 0.8 milliamperes. Let us assume that an r.f. input of 7 volts modulated at say 43 per cent. is applied to the grid. What will be the a.f. voltage appearing across the load resistance? The steady plate current obtained with an r.f. signal of 7 volts

will be 0.46 milliamperes. If the r.f. is modulated 43 per cent. it means that the r.f. voltage varies about its mean value, 7 volts, by 43 per cent. Therefore, it reaches maximum values of $7 + (7 \times 0.43)$ or 10 volts and minimum values of $7 - (7 \times 0.43)$ or 4 volts. The plate current corresponding to 10 volts input is 0.63 milliamperes and the plate current corresponding to 4 volts is 0.27. The a.c. plate current will therefore be one having an absolute peak of 0.63 milliamperes and a minimum of 0.27, the difference between these two being equal to twice the peak value of the a.c. current. This difference is 0.36 and dividing by 2 we get 0.18 as the peak value of the audio-frequency current in the plate circuit. Dividing this peak value of 0.18 by the square root of 2 to get r.m.s. values we have 0.128 as the effective a.c. plate current. This current in amperes multiplied by the load resistance gives the a.c. voltage. In this case it is $0.000128 \times 110,000$ ohms which gives 14.1 as the audio-frequency voltage. This value of audio-frequency output obtained by calculation agrees very closely with the measured value. This method of calculating detector output is therefore very effective and comparatively simple.

(Continued from page 357)

ning disc is placed backwards on the shaft or that the shaft is rotating in the wrong direction. The cure is obvious. Because of the 180-degree phase shift encountered in each vacuum tube stage, it is necessary to employ an even number of stages in the amplifier, otherwise the picture will be "negative" with the light and dark portions transposed. Hence, a negative picture indicates that we are employing the wrong number of stages or that a stage is inoperative.

If the picture travels across the field of vision from left to right, the receiver mechanism is leading that at the transmitter; if from right to left it is lagging. In either case the motor speed should be adjusted accordingly.

The picture may be seen "out of frame" either vertically or horizontally. If this occurs in the vertical direction, the trouble may be rectified by starting and stopping the receiving motor until the motors start off with the two scanning spirals in their correct relation.

Should the picture be out of frame horizontally, the neon lamp may be moved laterally or the disc may be shifted on the shaft. This may be due to phase displacement in the supply voltage causing one motor to lag behind or lead the other. This factor is variable and it is desirable to construct the mechanism so that the adjustment may be readily made. This may be done by having the neon lamp mounted in a fashion allowing lateral movement at will or by arranging the stator of the synchronous motor so that it may be rotated during operation.

It is impossible to give a comprehensive résumé of television because of limited space and because of the rapid strides being made. It is hoped that these few words may assist in visualizing the basic problems encountered.

AIRCRAFT RADIO DEVELOPMENT

(Continued from page 332)

3. Topography of country causes shift of zone.

The reed type or visual beacon is more practical, and has several inherent advantages. The principle is similar to the aural type just described, with the exception that two different modulated frequencies are transmitted from the two loops. These vary between 50 and 120 cycles per second, and are usually chosen about 20 cycles apart; frequencies of 65 and 85 cycles are most frequently used as the modulating frequencies.

The receiver output is connected to two electrically driven white-tipped reeds, held in a shock-proof box on the control dash. These reeds are tuned to the two transmitted modulation frequencies. When the plane is on its course, the amplitude of each two reeds is approximately the same, but as soon as the pilot deviates, one or the other reed has greater amplitude, and the pilot gives his ship right or left rudder depending upon which direction he is off course until the two reeds have the same amplitude again.

Either of these systems is good up to about 135 miles under ordinary conditions and still greater distances could be covered with higher frequencies.

Radio Altimeters

A barometric type of altimeter is quite unsatisfactory for land flying. The pilot is interested in his height above ground rather than above sea level. Two general types of radio altimeters which indicate height above ground are being perfected, one of which is the reflected-wave type, and the

(Continued on page 359)

Reflection of Sound

THE INTENSITY of the sound we hear at any point in a room when listening to the output of a loud speaker is a function of the intensity of the direct sound ray, the reflected ray, standing waves, and the amount of reverberation. The diagram on this sheet together with the following notes gives a simple idea of the effect of the direct and reflected rays.

The diagram shows a cone load speaker placed a short distance in front of a wall. During operation of the loud speaker sound waves will be radiated in all directions and if the listener is located at point A the sound he hears will be due to the direct ray and the reflected ray—the reflected ray being the one which leaves the loud speaker, strikes the wall and is then reflected into the room. The amount of energy reflected from the wall of course depends on the material composing the wall—ordinary hard walls are good reflectors and a major portion of the sound is reflected. If the walls are draped or are made of some acoustic material the amount of sound reflected is much less.

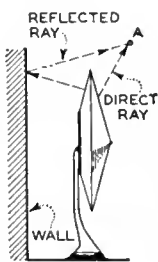

The phase relation between the two waves at the point where the listener is located determines the intensity of the sound (neglecting reverberation), and if the two waves are exactly opposite in phase very little sound will be heard. On the other hand, some sound will always be audible because reflections are also taking place from all other parts of the room. The effects of this type of reflections are prevented somewhat by the use of a baffle (although this is not the most important reason for the use of a baffle). Reflection is most noticeable at low frequencies.

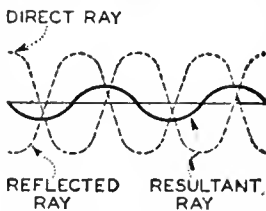

The curves on this sheet indicate graphically the effects which occur due to the direct and reflected rays. If the two waves are essentially 180 degrees out of phase the resultant, shown by the heavy line, is very small which means that the intensity of the sound is very low. However, reflection is not always a thing to be avoided. For example, it occurs in an auditorium and often adds atmosphere to the music being played.

Grid Current in Tubes

IN MAKING measurements, especially on power tubes, it is frequently found that a small amount of current flows in the grid circuit even though the grid has a negative bias. Offhand this seems very serious for we usually operate a tube at negative potential to prevent the flow of grid current. Actually, however, the current flowing in the grid circuit when the grid is negatively biased may not affect the operation of the tube seriously for the following reason.

In the first place, it should be understood that we operate the grid of a tube at negative voltages so as to make the input impedance of the tube very high; in fact, the input circuit of an ordinary amplifier may have an impedance of a million ohms at audio frequencies. Since the impedance is very high practically no power need be expended in the grid circuit to develop comparatively large voltages. If, on the other hand, the input impedance is low the power required to develop the same voltage will be larger, and, as a result, the tube is a less efficient amplifier.

Now if the a.c. voltage across the grid circuit is E then the impedance of the input of the tube will be equal to the voltage E divided by I, the a.c. current in the circuit. That is—

$$\text{Input impedance} = \frac{E_{ac}}{I_{ac}}$$

So if I is zero then the impedance is infinitely large while if I is large then the input impedance is low. But it must be remembered that I is an alternating current. The d.c. current flowing in the grid circuit may be any value at all without affecting the a.c. input impedance of the tube. And now we reach the important point: it is not the value of the grid current as read on a d.c. meter that is important but rather it is to what extent this current varies with the applied a.c. input signal. In most cases the grid current which flows with negative voltage on the grid is a "gas" current, and about the same amount of current flows at all negative values of grid voltage. Therefore, even when an a.c. signal is applied to the grid so as to make the grid voltage vary about the operating point, the current in the grid circuit is constant (at least practically so) and the a.c. current produced is very small. This makes the denominator of the equation very small and therefore the input impedance very high. In summary, it may be said that grid current at negative grid voltages does not affect the input impedance of a tube unless this current varies considerably with grid voltage.

other the capacity type. Experiments have been carried on by Dr. E. F. W. Alexander-son on the reflected-wave type and this instrument will be described first.

The phase of the returning wave is different from the phase of the transmitted wave due to time lag. If the distance is varied by an amount which is a fraction of a wavelength this variation will manifest itself in a variation of the phase of the returning wave relative to the phase of the transmitted wave. If the distance is varied by an amount of several wavelengths, then the phase of the returning wave will go through a corresponding number of cyclic changes in phase. Thus, if we have an instrument for ascertaining the phase of the returning wave and are able to count the number of cyclic changes, we are thereby able to make absolute measurements of the height above ground.

An oscillator will vibrate at its natural period only when the restoring forces which are contained in the oscillator itself are the only ones that exist. When these restoring forces are acted upon by outside forces, these forces either add or subtract from the inherent restoring forces. It will swing to a higher frequency when the restoring forces are in phase and swing to a lower frequency when the restoring forces are out of phase. The changes may be aural, graphic, or visual. In actual tests on a 95-meter wave, a graphic chart was made up to 4000 feet and the waves balanced out every 155 feet. Graphic altitude logs may also be used for surveying.

Beat Frequency Method

Another system for direct-reading indicating instruments would be by the beat-frequency method. Two antennas are used; for example, one of 10 meters and the other of 11 meters. The maxima of the beat frequency will occur at 25 meters altitude, 75 meters, and again at 125 meters. This could be used with indicating lights for landing in a fog or similar conditions. The strongest or 25 meter (80 feet) elevation could light a red light, the next or 75 meter (240 feet) height would light a yellow light, and the third or 125 meter (400 feet) elevation could light a green light. If the oscillators were set for a 2 per cent. difference instead of a 10 per cent. difference, the scale would be 5 times as large and the strongest maxima would be noted at 125 meters (400 feet), the next at 375 meters (1200 feet), and the third at 625 meters (2000 feet). By having an automatic arrangement for shifting the difference between the two oscillators, it is possible to measure the height of the plane above ground with sufficient accuracy for landing purposes.

Another type of radio altimeter is the one being developed by Ross Gunn of the Bellevue Naval Laboratory. This altimeter works upon the principle that metal plates or wires, sensitive to small changes in electrical capacity, function in accordance with the principle that a perceptible change in capacity takes place when two electrical conductors come within close proximity of a third conductor. Also the capacity of a condenser varies in inverse proportion to the distance between the plates. This altimeter does not rely upon the "echo" signal as in other types. Its sensitivity increases as the plane approaches the ground. It is reasonably accurate up to 150 to 200 feet altitude above ground. As little as 5 feet will record accurately. This type can be made to read direct. A 1000-kc. wave is transmitted from an antenna or plate and reacts with the other plate upon its approach to a conductor like the earth. Under actual tests, this altimeter was within 5 per cent. accurate up to 150 feet. There are no unusual adjustments. Two handicaps of this

(Continued on page 360)

TYPE 360 TEST OSCILLATOR



One of the new test oscillators for the radio service laboratory is now ready. It will deliver a modulated radio-frequency voltage at any point in the broadcast band (500 to 1500 kilocycles) and at 175 and 180 kilocycles. The tuning control is calibrated with an accuracy of 2 per cent.

The Type 360 Test Oscillator is intended to be used for neutralizing, gang- ing, and tuning of the radio-frequency stages in a receiver, and it is fitted with an output voltmeter for indicating the best adjustment. This voltmeter is of the copper-oxide rectifier type, and by means of a switch it may be connected across a 4000-ohm load or across the dynamic speaker of the receiver when making tests.

Price \$110.00

GENERAL RADIO COMPANY

30 State Street

Cambridge, Massachusetts

Wanted:

Representative in each town for new easy selling proposition to home-makers. Generous commissions, bonus and sales helps supplied. Especially attractive offer to club or civic workers. Apply

Box R. B. % The American Home
Garden City, N. Y.

ROBERT S. KRUSE

Consultant and Technical Writer

103 Meadowbrook Road, West Hartford, Conn.
Telephone Hartford 45327

Service Men— Set Builders— Dealers

We have a very interesting proposition for you about the

BROWNING-DRAKE screen-grid RADIO

Browning-Drakes always appealed to technical radio men. More Browning-Drake kits were sold than any other make. Send for this new proposition.

Browning-Drake Corporation
224 Calvary Street Waltham, Mass.

Extra Money! For Service Men

Extra
Enjoyment
for
Construction
Fans

A 1930
VOICE For
OLD SETS

RETURN COUPON FOR FREE BOOKLET!

You know dozens of people who cannot (or will not) buy a 1930 receiver, but who will spend a reasonable amount to secure 1930 tone quality. This free booklet tells about the profit possibilities of modernizing old sets with new Pilot transformers.

**PILOT RADIO
& TUBE CORP.**
323 BERRY STREET, BROOKLYN, N. Y.

PILOT RADIO AND TUBE CORP.
323 Berry Street, Brooklyn, N. Y.

Send me without obligation "A 1930 Voice For Old Sets"

NAME.....
ADDRESS.....
CITY.....STATE.....

Speech Power and Its Measurement

IN CONNECTION with a paper entitled "Speech Power and Its Measurement" by L. J. Sivian, published in October, 1929, *Bell System Technical Journal*, curves and data are given on two devices useful in many ways. Curves and circuits of the two units—a volume indicator and an impulse meter—appear on "Laboratory Information Sheet" No. 344 and the following are some notes regarding their use.

The volume indicator meter has been widely used for controlling amplification in radio broadcasting, in phonograph and film recording of speech and music, and for rapid measurement and control of speech levels. Essentially the volume indicator is a three-element vacuum-tube voltmeter with a rapid-action d.c. galvanometer in the plate circuit. The tube is operated on a part of its characteristic such that the rectified plate current is proportional to the square of the voltage input. The meter combined with the electrical circuit has a dynamic characteristic as shown by the curve on "Sheet" No. 341, which gives the maximum deflection as a function

of the duration of the a.c. input voltage. For inputs lasting more than about 0.18 seconds the maximum deflection remains the same, and, since the average syllable duration in speech is of the order of 0.2 seconds, it follows that the maximum deflection is approximately proportional to the mean power.

The impulse meter is essentially a peak-reading voltmeter and the circuit is designed so as to cause the plate current to reach its ultimate value with an input of as short a duration as possible. The time required for the galvanometer to reach its maximum deflection is determined by the dynamic characteristic of the meter and its associated plate circuit as well as by the time constant of the condenser-charging circuit connected to the grid of the tube. The curve, therefore, shows the rate at which the potential on the blocking condenser builds up and by reference to the curve it will be noted that the plate current reaches 80 per cent. of its ultimate value with an a.c. input of only approximately 0.015 seconds.

(Continued from page 359)

type are "background capacity" and tendency to "drift."

Conclusion

Radio is doing much toward aiding aerial navigation and making aviation a safe commercial possibility. Radio is doing much toward making aviation fool-proof and making it possible to fly in inclement weather with safety. Meteorological reports, radio beacon service, and direct communication are doing much toward making aviation a dependable institution. Radio control of airport landing lights will make night flying safer. As planes become larger and space and payload become less important, more dependable and larger apparatus can be used to advantage. All sciences are interdependent, and thus commercial aviation is benefited directly by radio development. Aviation, with the cooperation of radio, will give us the safest, most rapid, and cheapest transportation ever known to mankind.

MEASURING PERCENT-AGE MODULATION

(Continued from page 335)

cycles. In Fig. 4A the percentage of modulation is 18 per cent.; in Fig. 4B, 41 per cent., and in Fig. 4C the transmitter is seriously overloaded, since part of the cycle is completely suppressed. It is easy to see that the modulation no longer has a sinusoidal shape. The remark may be made that, even without the rotating mirror, the beginning of overloading can be seen directly upon the stripped picture on the tube. The unmodulated part of the carrier wave appears with great brilliance, since it affects the cathode ray twice as long as the ends of the stripe. The width of this bright part of the middle of the stripe becomes less and less with increasing degrees of modulation and shrinks to a lighted point in the stripe with more than 100 per cent. With a little practice the percentage modulation can be evaluated direct from the stripe.

An oscillograph of a broadcast transmitter is shown in Fig. 4D. This picture was taken with the arrangement shown in the heading illustration, i.e., with a h.f. amplifier in front of the tube. These pictures, which are of considerable value for the control of the transmission, show that nearly 100 per cent. modulation is present. With a vacuum-tube voltmeter and an indicating instrument for the determination of the degree of excitation, momentary overloads can hardly be seen due to the inertia of the instruments used. The instantaneous and easily readable cathode-ray oscillograph is, therefore, to be preferred for a continuous watch in the transmitting station.

The WGY-KGO Problem

In a report to the Commission, Martin Rice states that, since WGY has been operating simultaneously with KGO, 62 per cent. of reports from listeners in New York, Ohio, Indiana, Illinois, and Iowa complain of poor reception, while only 8 per cent. from that territory raised objections before the dual assignment went into effect. In Iowa, Nebraska, Colorado, Wyoming, Idaho, Utah, Nevada, Arizona, and Texas, 72 per cent. complain of reception quality, while prior to the present allocation, 88 per cent. in those states reported good quality. In California, where KGO used to receive no complaints, 32 per cent. of those writing in now report unsatisfactory reception.

Speech Power and Its Measurement

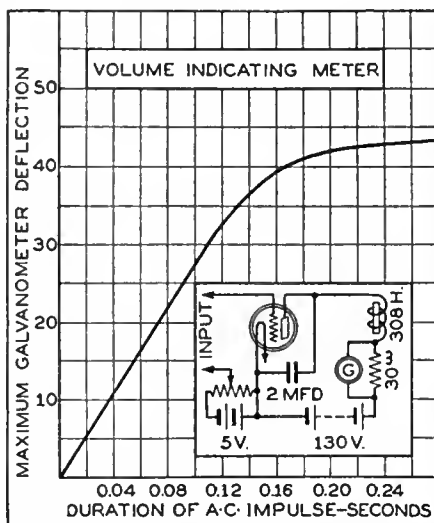
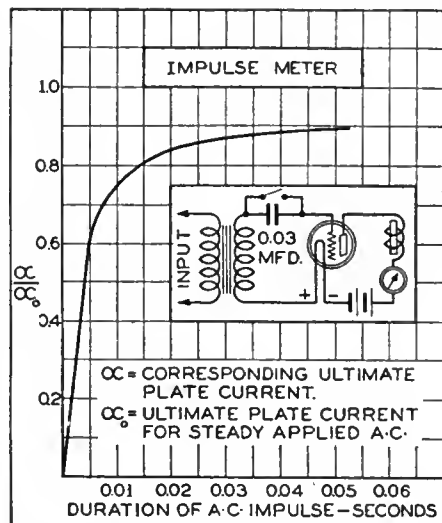

Regarding Grounds for A. C. Sets

IN THE INSTALLATION and use of a.c. radio receivers it is frequently found that more volume is obtained without any wire connected to the ground terminal than is obtained with a ground connection to the binding post. This effect has evidently given quite a few servicemen the impression that there was something wrong with the receiver. The fact is, however, that this quite common effect does not necessarily indicate that the receiver is defective.

The volume obtained from a receiver depends upon the ability of the antenna system to pick up signals and upon the gain of the radio receiver. Modern high-gain receivers have to be very carefully designed from the standpoint of shielding, filtering, and grounding to make them absolutely stable and if any one of these points is neglected the set will have some regeneration. On the other hand, if the set depends for some of its amplification on regeneration its performance will depend somewhat upon the conditions under which it is operated. Proper grounding is an important point in the prevention of regeneration and the lack of a

ground or a comparatively poor ground may cause an otherwise perfectly stable receiver to regenerate slightly.

This is the effect which is responsible for the peculiar operation of a.c. receivers with and without proper ground connections. With a proper ground the set has a gain approximating that which its makers intended it should have. If, however, no ground is used some regeneration will exist which will generally tend to increase the gain and, as a result, more volume is obtained. The disadvantage of not using a ground, however, is that this increased gain may only be obtained over a small part of the dial and at other points the set may tend to oscillate or the first tuned circuit may be thrown out of alignment so that the selectivity is impaired. For these reasons it is always advisable to operate a receiver with a ground if it is intended that it should have one. If for some reason the receiver must be operated without a ground it is worth while to try reversing the plug in the light socket in order to determine the position which gives the most satisfactory operation.

4th RMA Trade Show ATLANTIC CITY

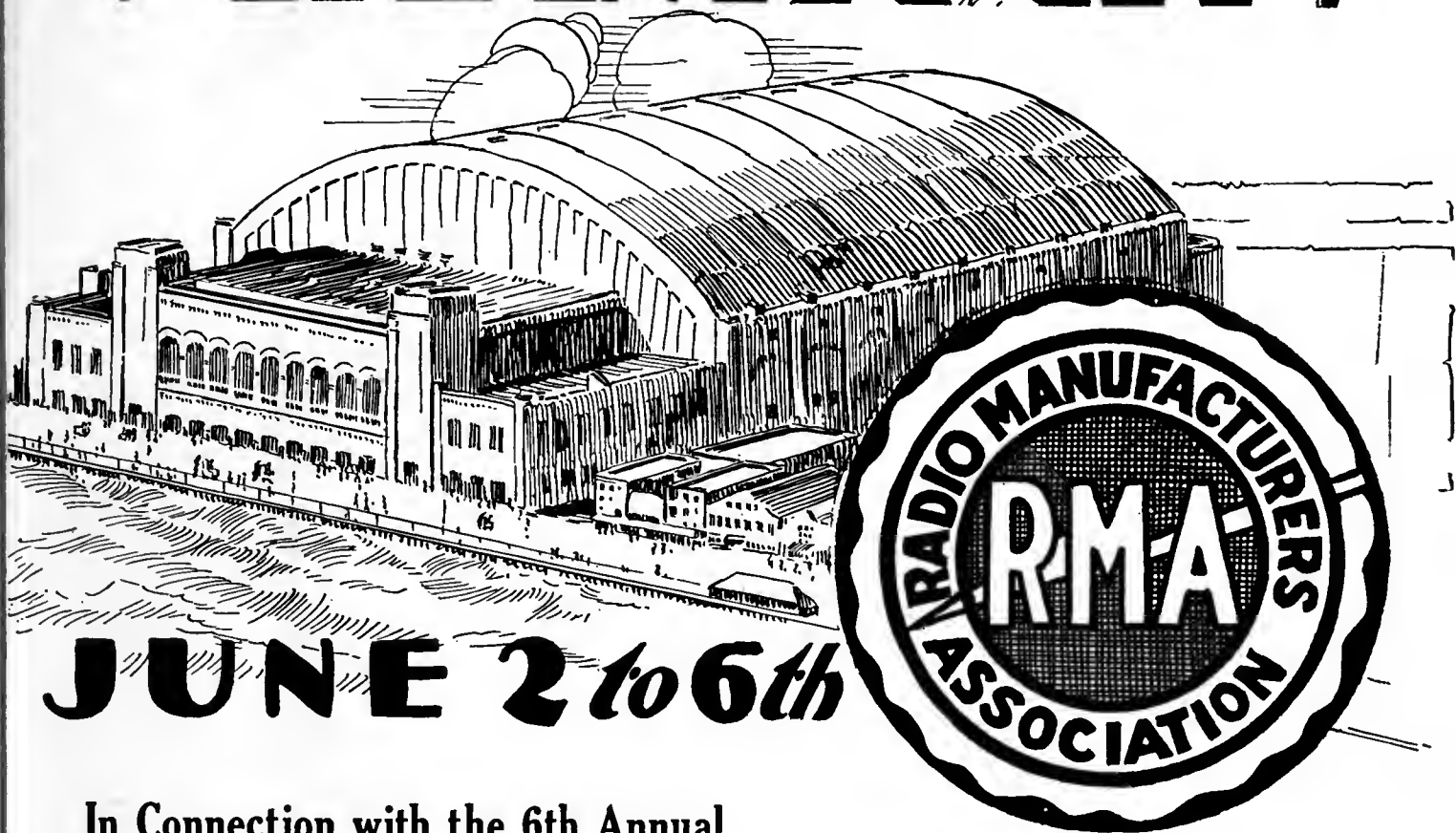

JUNE 2 to 6th

In Connection with the 6th Annual R. M. A. Convention and the Federated Radio Trade Assn. Convention

The fourth annual R.M.A. trade show will be held this June in Atlantic City, the playground of America, the country's pre-eminent convention city. It will be the largest trade show in the history of the radio industry, twice as large as last year's Chicago show.

Atlantic City offers more hotels, better accommodations, more to see, hear and do—this is the one trade show you cannot afford to miss.

The Atlantic City Auditorium, facing the boardwalk and cooled by the breezes of the Atlantic Ocean, is the largest convention hall in the country. All exhibition booths and demonstration rooms will be under one roof, on one floor, making it easy to get a comprehensive view of the entire trade show.

The June trade show marks the beginning of radio's new year. The most responsible manufacturers exhibit and demonstrate their latest models and accessories on this occasion. It behooves everyone connected with the radio industry to visit the trade show this year, which will be the most interesting and important radio gathering ever convened.

Hotel reservations should be made through the Atlantic City Convention Bureau, Atlantic City, New Jersey. Invitation credentials for the trade show will be mailed to the trade about May 1st.

Reduced round trip rates on all railroads.

Radio Manufacturers' Association Trade Show, Room 1904, Times Bldg., New York

Under Direction of U. J. Herrmann and G. Clayton Irwin, Jr.

→
FIRST MINUTE

Let your customer hold a watch on any set equipped with Arcturus Tubes. Snap the switch and check the starting time...the program is there in 7 seconds!

THIS 3-MINUTE DEMONSTRATION

PROVES ARCTURUS SUPERIORITY TO ANY TUBE BUYER



←
SECOND MINUTE

Let your customer listen to the clear, pure tone that is characteristic of Arcturus Tubes. There's no annoying hum, no trace of outside noises, to mar the beauty of any program.



THE self-evident superiority of Arcturus Blue Tubes means increased sales and extra profits. If you have not checked Arcturus quality yourself, ask your jobber for a demonstration. *Proved performance, not sales talk, has made Arcturus the fastest growing tube in the radio industry today.*

ARCTURUS RADIO TUBE COMPANY
Newark, N. J.

→
THIRD MINUTE

Show your customer, on the meter, that Arcturus Tubes easily withstand exceptional overloads. This unusual stamina explains Arcturus' long life.

they're

blue!



ARCTURUS

Quick Acting
RADIO TUBES



