



Über dieses Buch

Dies ist ein digitales Exemplar eines Buches, das seit Generationen in den Regalen der Bibliotheken aufbewahrt wurde, bevor es von Google im Rahmen eines Projekts, mit dem die Bücher dieser Welt online verfügbar gemacht werden sollen, sorgfältig gescannt wurde.

Das Buch hat das Urheberrecht überdauert und kann nun öffentlich zugänglich gemacht werden. Ein öffentlich zugängliches Buch ist ein Buch, das niemals Urheberrechten unterlag oder bei dem die Schutzfrist des Urheberrechts abgelaufen ist. Ob ein Buch öffentlich zugänglich ist, kann von Land zu Land unterschiedlich sein. Öffentlich zugängliche Bücher sind unser Tor zur Vergangenheit und stellen ein geschichtliches, kulturelles und wissenschaftliches Vermögen dar, das häufig nur schwierig zu entdecken ist.

Gebrauchsspuren, Anmerkungen und andere Randbemerkungen, die im Originalband enthalten sind, finden sich auch in dieser Datei – eine Erinnerung an die lange Reise, die das Buch vom Verleger zu einer Bibliothek und weiter zu Ihnen hinter sich gebracht hat.

Nutzungsrichtlinien

Google ist stolz, mit Bibliotheken in partnerschaftlicher Zusammenarbeit öffentlich zugängliches Material zu digitalisieren und einer breiten Masse zugänglich zu machen. Öffentlich zugängliche Bücher gehören der Öffentlichkeit, und wir sind nur ihre Hüter. Nichtsdestotrotz ist diese Arbeit kostspielig. Um diese Ressource weiterhin zur Verfügung stellen zu können, haben wir Schritte unternommen, um den Missbrauch durch kommerzielle Parteien zu verhindern. Dazu gehören technische Einschränkungen für automatisierte Abfragen.

Wir bitten Sie um Einhaltung folgender Richtlinien:

- + *Nutzung der Dateien zu nichtkommerziellen Zwecken* Wir haben Google Buchsuche für Endanwender konzipiert und möchten, dass Sie diese Dateien nur für persönliche, nichtkommerzielle Zwecke verwenden.
- + *Keine automatisierten Abfragen* Senden Sie keine automatisierten Abfragen irgendwelcher Art an das Google-System. Wenn Sie Recherchen über maschinelle Übersetzung, optische Zeichenerkennung oder andere Bereiche durchführen, in denen der Zugang zu Text in großen Mengen nützlich ist, wenden Sie sich bitte an uns. Wir fördern die Nutzung des öffentlich zugänglichen Materials für diese Zwecke und können Ihnen unter Umständen helfen.
- + *Beibehaltung von Google-Markenelementen* Das "Wasserzeichen" von Google, das Sie in jeder Datei finden, ist wichtig zur Information über dieses Projekt und hilft den Anwendern weiteres Material über Google Buchsuche zu finden. Bitte entfernen Sie das Wasserzeichen nicht.
- + *Bewegen Sie sich innerhalb der Legalität* Unabhängig von Ihrem Verwendungszweck müssen Sie sich Ihrer Verantwortung bewusst sein, sicherzustellen, dass Ihre Nutzung legal ist. Gehen Sie nicht davon aus, dass ein Buch, das nach unserem Dafürhalten für Nutzer in den USA öffentlich zugänglich ist, auch für Nutzer in anderen Ländern öffentlich zugänglich ist. Ob ein Buch noch dem Urheberrecht unterliegt, ist von Land zu Land verschieden. Wir können keine Beratung leisten, ob eine bestimmte Nutzung eines bestimmten Buches gesetzlich zulässig ist. Gehen Sie nicht davon aus, dass das Erscheinen eines Buchs in Google Buchsuche bedeutet, dass es in jeder Form und überall auf der Welt verwendet werden kann. Eine Urheberrechtsverletzung kann schwerwiegende Folgen haben.

Über Google Buchsuche

Das Ziel von Google besteht darin, die weltweiten Informationen zu organisieren und allgemein nutzbar und zugänglich zu machen. Google Buchsuche hilft Lesern dabei, die Bücher dieser Welt zu entdecken, und unterstützt Autoren und Verleger dabei, neue Zielgruppen zu erreichen. Den gesamten Buchtext können Sie im Internet unter <http://books.google.com> durchsuchen.

This is a reproduction of a library book that was digitized by Google as part of an ongoing effort to preserve the information in books and make it universally accessible.

Google™ books

<https://books.google.com>

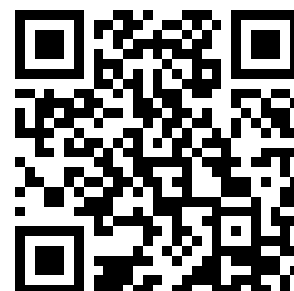

AGE
TE
Ed.

PARY



LELAND • STANFORD • JUNIOR • UNIVERSITY

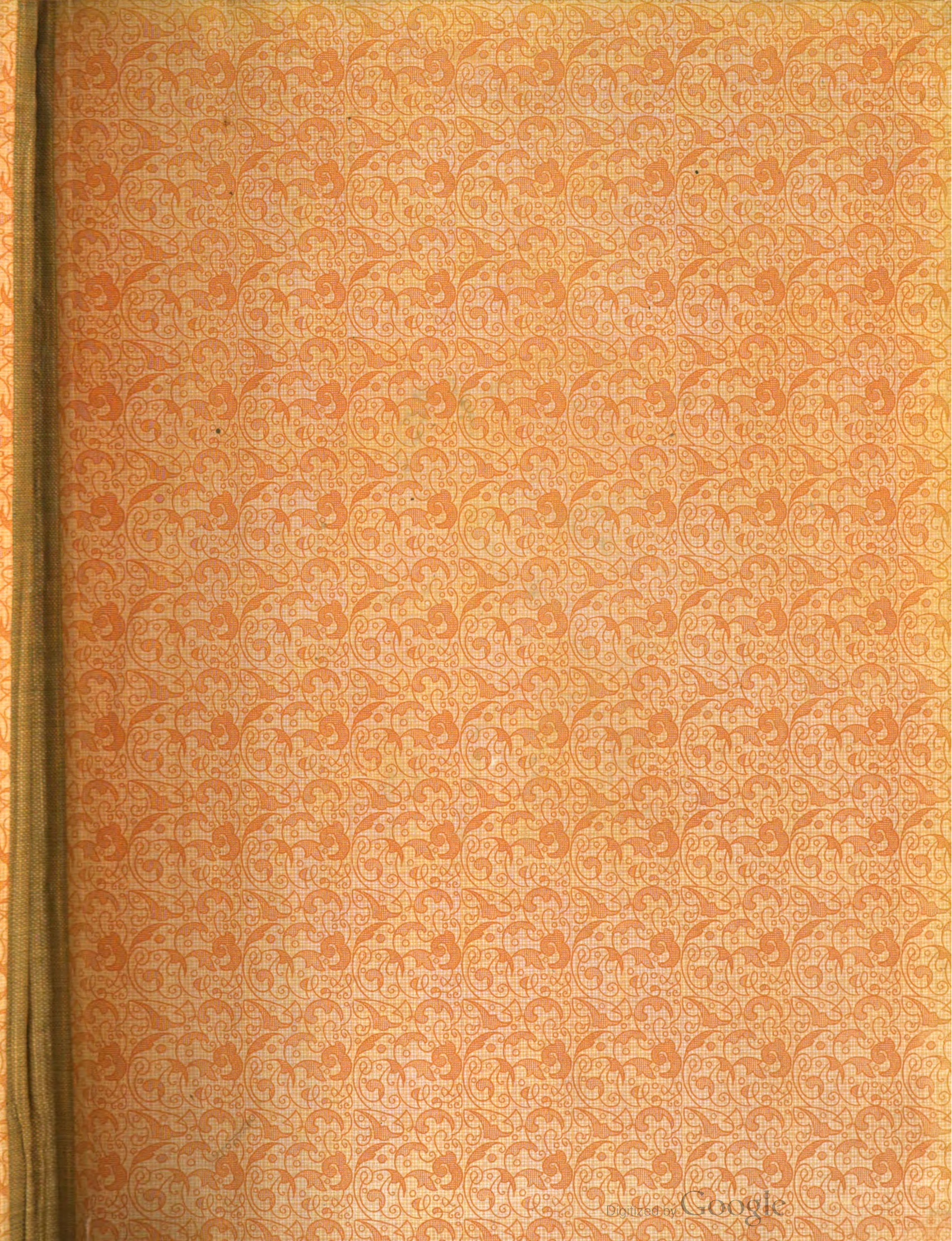

Railway Age Gazette

MECHANICAL EDITION

INCLUDING THE
AMERICAN ENGINEER

Established 1832

INDEX TO VOLUME LXXXIX
1915

Published by the
Railway Age & American Engineer Co.

ALSO OF THE

DAILY RAILWAY AGE GAZETTE

ISSUED DURING THE

M. M. AND M. C. B. CONVENTIONS

INDEX, 1915

VOLUME LXXXIX

227049

A

Accidents due to poor lighting.....	238†
Accidents, Noise and.....	526†
Accounting, Material store expenses, store-keepers' convention.....	287
Acetylene (See Oxy-Acetylene).	
Acme Supply Co., Reverse unfold diaphragm.....	1353*
Adams, H. C., Standardization of coal preparation, Fuel convention.....	275
Agnew, "Big Bill" and "Blue Monday," Harvey De Witt Wolcomb.....	533
Ahsiuolh, N. H., Piece work and bonus systems in the boiler shop.....	240*
Ahsiuolh, N. H., Repairing locomotive boiler tubes.....	83*
Air Brake Association convention.....	295*
Air Brake Association (see Meetings).	
Air brake hose, Device for mounting.....	134*
Air brake hose, Goodyear.....	484*
Air brake maintenance, M. C. B. convention.....	1395*
Air brake system, Effect of moisture in.....	623
Air brakes, Handling of, T. E. A. convention.....	509
Air brakes, Inspection and maintenance of, on freight cars, by Robert Barnaby.....	406
Air brakes, Maintenance of.....	1356‡
Air brakes, Testing devices for, L. & N.....	470*
Air compressor, High speed centrifugal, De Laval.....	374*
Air compressor with piston valve and automatic cut-off, Ingersoll-Rand.....	643*
Air compressor, Small steam driven, unit, Ingersoll-Rand.....	428*
Air compressor valves, Simplate.....	545*
Air hose, Device for mounting, by B. N. Lewis.....	134*
Air motors, Apparatus for testing, Tool Foremen's convention.....	414*
Air pump air cylinders, Oiling, by E. A. Murray.....	408*
Air pump cylinder heads, Reinforced gaskets for, by J. A. Jesson.....	469*
Air pump cylinders, Reboring, by J. A. Jesson.....	138*
Air pump gland nut lock.....	322*
Air pump packing rings, Chuck for finishing, by F. R. Stewart.....	580*
Air pump rack, by John H. Nagle.....	90*
Air pump, Repairing 9½-in. cylinder heads.....	530*
Air pump repairs, Special chuck for.....	183*
Air pump reversing rods, Repairing worn, by J. A. Jesson.....	242*
Air pumps, Cleaning, by W. E. Johnson.....	82*
Air pumps, Device for placing, by W. S. Whitford.....	581*
Albers, L. H., President's address, Air Brake convention.....	295
Allegheny Steel Co., Forged steel truck side frame.....	1318*
Aluminum alloy.....	98†
American Car & Foundry Co., Rolled steel truck frames.....	420*
American Car & Ship Hardware Co., Water glass guard.....	490*
American Electric Railway Association (see Meetings).	
American Engineering Co., Steel car sand blasting plant.....	276†
American Malleable Castings Assn., Exhibit.....	1319*
American Mason Safety Tread Co., Device to prevent ladders from slipping.....	1285*
American Railway Master Mechanics' Association, A successful convention.....	1287‡
American Railway Master Mechanics' Association convention.....	1211*, 1270*
American Railway Master Mechanics' Association, Election of officers.....	1303
American Railway Master Mechanics' Association, Result of letter ballot.....	565
American Railway Master Mechanics' Association, Revision of standards and recommended practice.....	1217*
American Railway Tool Foremen's Association convention.....	409*
American Railway Tool Foremen's Association (see Meetings).	
American Railroad Master Timmers', Copper-smiths' and Pipefitters' Assn. (see Meetings).	
American Saw Mill Machinery, Variety wood worker.....	1281*
American Society of Mechanical Engineers.....	51, 647
American Society of Mechanical Engineers (see Meetings).	
American Society for Testing Materials (see Meetings).	

American Tool Co., Portable lathe.....	97*
American Vanadium Co., Carbon-Vanadium forging steel.....	1286
Anderson, J. E., Engine failures, their cause and cure.....	587
Andrus, C. H., Boring front end main rod brasses.....	196*
Annealing, Electric furnace for, by T. F. Bailey.....	481
Anthony, J. T., Combustion in locomotive fireboxes, A. S. M. E.....	10
Anti-Friction Roller Bearing Co., Journal bearing.....	141*
Anvil attachment for oblique bending, Blacksmiths' convention.....	480*
Appleton, W. U., Suggestions for a properly kept roundhouse.....	187
Appliances, Modern, on large locomotives, T. E. A. convention.....	490*
Apprentices, Keeping by sympathy and cooperation, by Joseph Smith.....	90†
Apprentice, Helping the, by H. E. Blackburn.....	531
Apprentice, How can I help the.....	582
Apprentice, How can I help the, By J. H. Pitard.....	531
Apprentice, How can I help the, competition.....	642
Apprentice letter competition, The.....	383‡
Apprentice, The letters.....	496‡
Apprentice school, The.....	439‡
Apprentice school car, Staten Island.....	633
Apprentice, The special.....	369*
Apprentice, The special, by Herman Schoenen.....	268‡
Apprentice, Start the, right.....	270†
Apprentice, Take a real interest in the, by A. Mac'Orkindale.....	585
Apprentice, Value of incentive to, by J. Campbell.....	641
Apprentices, Advice to.....	531
Apprentices, An inspiring address to, by George M. Basford.....	155‡
Apprentices, Give responsibility to.....	185
Apprentices, Model locomotives built by Eric.....	532
Apprentices, Points for, to ponder.....	41*, 456*
Apprentices, Training official material and journeymen, by F. H. Thomas.....	132
Apprenticeship, Does modern, pay.....	370
Apprenticeship, Modern, by Robert N. Miller.....	248
Apprenticeship, Two good suggestions relating to.....	532
Arc welder, Constant current, Lincoln.....	638†
Arc welding, Answers to some questions on, by J. F. Lincoln.....	490*
Arc welding, Blacksmiths' convention.....	195
Arc welding in boiler maintenance, Boiler Makers' convention.....	476*
Ash pans, Fuel convention.....	312
Association, A car department.....	281
Association, Centralized control of.....	496‡
Association of Railway Electrical Engineers' meeting.....	1208‡
Associations, Consolidation of mechanical.....	1325
Atchison, Topeka & Santa Fe, Keeping boiler inspection records.....	330‡, 384‡, 1307‡, 1356‡
Atchison, Topeka & Santa Fe, Pacific type Locomotive.....	635*
Atchison, Topeka & Santa Fe, Safety cutting gauge.....	217*
Atchison, Topeka & Santa Fe, Steel coaches for.....	44*
Atchison, Topeka & Santa Fe, Testing car roofs.....	21*
Atchison, Topeka & Santa Fe, Training official material and journeyman apprentices.....	300*
Athey Co., Cloth-lined metal weather strips.....	370
Atlantic Coast Line, Double tire flanging tool.....	260*
Atlantic Coast Line, Finishing car and engine truck brasses by grinding.....	308*
Atlantic Coast Line, Finishing cylinder cocks.....	193*
Atlantic Coast Line, Gage for pilot coupler.....	195*
Atlantic Coast Line, Guard for vise tail piece.....	216*
Atlantic Coast Line, Jigs for grinding guide bars.....	247*
Atlantic Coast Line, Relief valve for superheater locomotives.....	416*
Atlantic Coast Line, Repairing 9½-in. cylinder heads.....	530*
Atlantic Coast Line, Repairing worn tail braces.....	90*
Atlantic Coast Line, Removable wedge bolt.....	591*
Atlantic Coast Line, Shoe and wedge chuck for milling machine table.....	591*

Atlantic Coast Line, Stenciling gage for freight cars.....	468*
Autogenous welding (see Welding, also see Oxy-acetylene Welding).	
Averill, E. A., What the stoker has done for the locomotive, A. S. M. E.....	11
Axles, Device for straightening bent.....	631*

B

Babbitt furnace for driving box hub liners, C. St. P., M. & O.....	527*
Babcock, A. H., Southern Pacific six-volt electric headlight equipment.....	613*
Bailey, T. F., Electric furnace for reheating, heat treating and annealing.....	481
Ball bearings, Strength of, S. K. F.....	48†
Ball joint connection, Main reservoir, Franklin Railway Supply Co.....	254*
Ball joint connection for main reservoir, Barco.....	487*
Ballantine, N. D., The Mikado vs. the consolidation.....	615
Baltimore & Ohio, Staten Island lines, Apprentice school car.....	369*
Band saw, Metal cutting (see machine tools)	
Barco Brass & Joint Co., Ball joint connection for main reservoirs.....	487
Barco Brass & Joint Co., Flexible pipe connection between engine and tender.....	1285*
Barco Brass & Joint Co., Smokebox blower fitting.....	595*
Barco Brass & Joint Co., Tank hose strainer.....	1199*
Barnum, E. S., Road tests for determining front end conditions.....	454*
Barnaby, Robert, Inspection and maintenance of freight car brakes.....	406
Barometric condenser as an open water heater, by D. P. Morrison.....	634*
Barr, H. Edsil, Pneumatic light forging hammer.....	147*
Barton, D. E., The best practices in engine house work.....	139
Basford, George M., Address to apprentices.....	185
Baxter, H. M., Tests of lubricants.....	225
Beading tool, Special, by Peter E. McIntosh.....	137*
Bean, G. M., Fuel oil for locomotive use.....	280*
Beandry & Co., Inc., Motor driven power hammer.....	319*
Becker, E., Some factors in locomotive maintenance.....	140
Bell, J. Snowden, Variable exhausts, M. M. convention.....	1290*
Bell yoke bearing reamer, by F. W. Bentley, Jr.....	36*
Belt shifter, Dearborn Steel & Iron Co.....	543*
Belt stick, Safety, Ready Tool Co.....	597*
Benness, E. H., Cast steel truck side frame.....	645*
Bentley, F. W., Jr., Bell yoke bearing reamers.....	36*
Bentley, F. W., Jr., Jig for drilling dry pipe collars.....	81*
Bentley, F. W., Jr., Post cluster for extension cord plugs.....	192*
Bentley, F. W., Jr., Reclaiming worn lubricator plugs.....	252*
Berdan, E. G., Brake rigging.....	483*
Bessmer & Lake Erie, Shop kinks, Blacksmiths' convention.....	480*
Bettendorf Co., All-steel box car.....	1398*
Betton, J. M., Sand blast helmet.....	146*
Betts, E. E., Proper handling of equipment.....	629
Beyer, O. S., Jr., Tonnage rating, T. E. A. convention.....	502
Billing machine, M. C. B., Burroughs.....	1354
Blackburn, H. E., Helping the apprentice.....	582
Blacksmiths' Association (see International Railroad Blacksmiths' Association).	
Blossom, H. F., Freight car stenciling outfit.....	458*
Blower fitting, Smokebox, Barco.....	595*
Blower, High speed, De Laval.....	374*
Blower pipe drain fitting, Watertown.....	45*
Blueprints, Waterproofing, Watertown.....	498†
Boiler check bodies, Chuck for finishing.....	133*
Boiler design in respect to heating surface, by F. J. Cole, at A. S. M. E.....	5
Boiler feed Water, Treating locomotive, Boiler Makers' convention.....	314
Boiler inspection competition, 439‡, 496‡.....	604‡
Boiler inspection law, Results of the, by Frank McManamy.....	190
Boiler inspector and his job, The.....	635*
Boiler inspector's facilities and methods of working, by W. J. Gillispie.....	636
Boiler inspector's competition, prize article, by T. T. Ryan.....	635*
Boiler Makers' Association (see Master Boiler Makers' Association).	
Boiler patch bolt, by Peter E. McIntosh.....	137*

Page numbers under 1,000 refer to *Railway Age Gazette, Mechanical Edition*; those over 1,000 refer to the *Daily Railway Age Gazette*. *Illustrated article; ‡ editorial; † short non-illustrated article or note; ‡ communication.

Boiler plugs, Failure of fusible tin..... 612
 Boiler shell, Reduction of strength in cor-rolled or pitted, Boiler Makers' convention 315
 Boiler shop, Piece work and bonus systems in the, by N. H. Ahsiuoh..... 240*
 Boiler tube cutter, Apparatus for driving, Tool Foremen's convention..... 410*
 Boiler tube cutter, by Lewis Lebovitz..... 542*
 Boiler tube cutter, Superheater, Tool Foremen's convention..... 409*
 Boiler tube welding, Master Blacksmiths' convention..... 471
 Boiler tubes, Electric process for safe-end- ing, by L. R. Pomeroy..... 469*
 Boiler tubes, Lohmannized..... 1285†
 Boiler tubes, Melted, by E. A. Murray..... 4‡
 Boiler tubes, Repairing, by N. H. Ahsiuoh..... 83*
 Boiler tubes, Using old, as pipe..... 192*
 Boiler washing and filling system for small roundhouses, by William Wells..... 251*
 Boiler washing, M. M. convention..... 1296*
 Boilers, A few facts about inspecting..... 365
 Boilers, Care of, in winter..... 56‡
 Boilers, Design, construction and inspection of locomotive..... 1272
 Boilers of locomotives held out of service... 103†
 Boilers, Y-fitting for washing out..... 530*
 Bolt heading machine, Continuous motion hammer, National..... 373*
 Bolts with battered heads, Reclaiming..... 39*
 Bonus system, Fixing standard time for a... 192
 Bonus system, Piece work and, in the boiler shop..... 240*
 Bonus system, The, by W. H. Wolfgang... 108‡

Books

Catechism of U. S. Safety Appliances, by J. D. MacAlpine..... 211
 Compressed Air, by Theodore Simons... 3
 The Electric Furnace and Metallurgical Work, Bureau of Mines..... 157
 Electric Railway Handbook, by Albert S. Richey..... 605
 Examination Questions and Answers, T. E. Assoc..... 157
 Experience in Efficiency, by Benjamin A. Franklin..... 385
 Graphic Methods for Presenting Facts, by Willard C. Brinton..... 57
 Heat Treatment of Steel, by Editors of Machinery..... 107
 How to Make Low Pressure Trans- formers, by Prof. F. E. Austin..... 555
 The Influence of Smoke on Health, Uni- versity of Pittsburgh..... 57
 Installing Efficiency Methods, by C. E. Knoepfel..... 107
 Mechanical World Electrical Pocket Book..... 212
 Mechanical World Pocket Diary and Year Book..... 212
 Official Proceedings of the Ninth An- nual Convention of the Master Boiler Makers' Association..... 555
 The Origin of Coal, by David White, et al..... 57
 Oxy-Acetylene Welding and Cutting, by C. H. Burrows..... 331
 Oxy-Acetylene Welding and Cutting, by Calvin F. Swingle..... 497
 Practical Mechanics and Allied Sub- jects, by J. W. L. Hale..... 441
 Proceedings of the Air Brake Associa- tion..... 441
 Proceedings of the American Electric Railway Association..... 269
 Proceedings of the American Institute of Electrical Engineers..... 331
 Proceedings of the American Railway Tool Foremen's Association..... 3
 Proceedings of the International Rail- way Master Blacksmiths' Association... 3
 Proceedings of the Master Tinner, Coppersmiths and Pipefitters' Associa- tion..... 385
 Proceedings of the Traveling Engineers' Association..... 57
 Resuscitation, by Charles A. Lauffer, M. D..... 331
 Rules for the Construction of Station- ary Boilers, A. S. M. E..... 269
 Steam Charts, F. O. Ellenwood..... 157
 Tests of Metals and Other Materials, War Dept..... 269
 United States Safety Appliances, M. C. B. Association..... 211
 Universal Safety Standards, Machine Shop and Foundry..... 212
 University of Illinois Bulletins..... 331
 Boston & Maine, Freight car stencilling out- fit..... 458*
 Boring and Turning Mills (see Machine tools).
 Bourne, G. L., Locomotive superheaters, A. S. M. E..... 12*
 Bourrell, W. A., Brine tank drain valve... 261*
 Boutell, Hugh G., Indicator reducing mo- tion..... 563*
 Bouter, H., Trifling defects in interchange, Car Inspectors' convention..... 523
 Brake and signal equipment, M. C. B. con- vention..... 1334*
 Brake beam fulcrum, Forged, Damascus Brake Beam Co..... 144*
 Brake beam fulcrum, Solid forged, Damas- cus..... 1382*

Brake beam safety hanger, E. O. Elliott.... 431*
 Brake beam safety strap, Former for, Black- smiths' convention..... 480*
 Brake beam strut, Forged steel, Buffalo Brake Beam Co..... 1398*
 Brake beam, The No. 2..... 1383‡
 Brake, Electro-Pneumatic, T. E. A. conven- tion..... 507
 Brake, Hand, for freight cars, National Brake Co..... 258*
 Brake hanging and the M. C. B. journal bearing..... 270‡
 Brake, Lever hand, D. R. Niederlander... 428*
 Brake rigging, Berdan..... 483*
 Brake shaft drop handle and ratches, B. R. & P..... 43*
 Brake shaft supports, Formers for bending, Blacksmiths' convention..... 480*
 Brake shoe and brake beam equipment, M. C. B. convention..... 1335*
 Brake shoe, Safety, A. Mitchell..... 320
 Brake slack adjuster, Johns-Manville..... 1319*
 Brake slack adjuster, Manual, Johns-Man- ville..... 644*
 Brakes, 100 per cent operative in freight service, Air Brake convention..... 297
 Brakes, Hand, on heavy passenger cars, Air Brake convention..... 298
 Brakes, Variable load for freight cars... 1308‡
 Braking trains, The art of..... 269‡
 Brinckerhoff, F. M., Practice versus theory in design..... 108‡
 Brine tank drain valve, W. A. Bourell... 261*
 British all-steel kitchen cars..... 178*
 British design of reciprocating and revol- ving parts, by H. A. F. Campbell..... 443*
 Britton, J. R., Systematic value setting on locomotives..... 366
 Brooms, Manufacturing, by B. N. Lewis... 407*
 Brown Engineering Co., General utility vise for drill press..... 255*
 Brown, H. M., Removing indentations in superheater smoke tubes..... 40*
 Brown, L., Defective box cars..... 30
 Brown, R. E., Double tire flanging tool... 308*
 Brown, R. E., Finishing car and engine truck brasses by grinding..... 193*
 Brown, R. E., Finishing cylinder cocks... 195*
 Brown, R. E., Jigs for grinding guide bars 242*
 Brown, R. E., Shoe and wedge chuck for milling machine table..... 591*
 Brunelle, Geo. J., Cause of high speed steel tool failures..... 369
 Buchanan, William, Relation of the paint shop to the repair yard..... 28
 Buckeye Jack Mfg. Co., Emergency jack... 259*
 Buffalo Brake Beam Co., Forged Steel Brake beam strut..... 1398*
 Buffalo, Rochester & Pittsburgh, Air pump rack..... 90*
 Buffalo, Rochester & Pittsburgh, Brake shaft drop handle and ratchet..... 43*
 Buffalo, Rochester & Pittsburgh, Steel frame caboose..... 301*
 Buffer, Radial, Economy Devices Corp.... 1322*
 Bundy, C. L., Defective box car..... 80
 Burner, Paint, Mahr..... 1322*
 Burnett, R. W., The standard box car—a negative viewpoint..... 121
 Burroughs Adding Machine Co., M. C. B. bill machine..... 1354
 Buying, Railroads have started..... 553‡

C

California Valve & Air Brake Co., Dia- phragm-operated triple valve..... 92*
 California Valve & Air Brake Co., Train pipe compensating valve..... 94*
 Calvert, R. F., Simple furnace for melting brass..... 36*
 Cambria Steel Co., Slick friction spring draft gear..... 259*
 Campbell, H. A. F., Reciprocating and re- volving parts..... 109*, 163*, 215,
 Campbell, J., Value of incentive to the ap- prentice..... 531
 Canadian Government Railways, Adjustable drilling stand..... 42*
 Canadian Northern, Disinfectant arrange- ment for passenger cars..... 466*
 Canadian Northern, Exhaust passage drain valve..... 586*
 Canadian Northern, Expansion joint for water heater..... 628*
 Canadian Northern, Pillar crane for ma- chine tool work..... 360*
 Canadian Northern, Step-ladders for sleep- ing cars..... 238*
 Canadian Northern, Towel receptacle for sleeping cars..... 461*
 Canadian Pacific, All steel box car..... 399*
 Canadian Pacific, End construction of stock cars..... 29*
 Canadian Pacific, First 4-8-2 type locomotive in Canada..... 556*
 Canadian Pacific, Grinding wheel protection. Canadian Railway Club (see Meetings)
 Capacity, Increased, in existing locomotives 1‡

Car

All-steel automobile, Union Pacific..... 73*
 Apprentice school car, B. & O., Staten Island lines..... 369*
 Body framing, Long Island steel sub- urban car..... 404*

Car—(Continued)

Box, The 36-ft..... 1307‡
 Box, All-steel, Bettendorf..... 1398*
 Box, Defective..... 1308‡
 Box, Defective, by L. Brown..... 30
 Box, Defective, by C. L. Bundy..... 80
 Box, Defects of, and their remedies, by R. N. Miller..... 171
 Box, end door, by Geo. E. McCoy..... 173*
 Box, Improper loading of..... 233
 Box, No "Greatest Defect" in..... 20
 Box, Overhead inspection of, M. C. B. convention..... 1367
 Caboose, Eight-wheel, with steel under- frame, P. S. & N..... 231*
 Caboose with steel center sills, Erie... 25*
 Caboose, Steel frame, B. R. & P..... 301*
 Ceiling fan, safety..... 1352*
 Construction in 1914..... 1‡
 Construction, M. C. B. convention..... 1368*
 Coupler committee, Report of the..... 1355‡
 Couplers, M. C. B. convention..... 1359*
 Curtain rollers, Improved Rex..... 1352*
 Derailments, causes and a remedy... 619*
 Diaphragm curtains, Improved Rex... 1382*
 Diaphragm, Reverse unfold, Acme... 1353*
 Diaphragms, Rex metal..... 1321*
 Dining chairs..... 300*
 Doctor of, the..... 628
 Doors, box..... 1355‡
 Door, Flush, for box, Ralston..... 1354*
 Draft arms, Woolen..... 1383*
 Draft equipment, M. C. B. convention... 1390
 Draft rigging, Friction spring, Cambria Dynamometer, Japanese railways... 66*
 Drafting, Russian..... 606*
 Electric lighting system..... 467
 Eliminate old from interchange service End construction, Jersey Central steel baggage and mail cars..... 125*
 End construction, Union Pacific freight Foreign, Billing repairs on..... 106‡
 Frame, Unit construction, Erie steel cars 357*
 Freight, Increased mileage..... 1323‡
 Freight, Impact between..... 1383‡
 Freight, Impact between, in switching service, M. C. B. convention..... 1391*
 Freight, Stencilling outfit, by H. F. Blossom..... 458*
 Frozen, Thawing out, C. & W. I..... 574*
 Handling properly..... 625*
 Inspection, Freight..... 440‡
 Inspection, Uniformity in..... 468
 Journals, Lubrication of..... 19
 Journals, Maintenance of..... 1307‡
 Kitchen, British all-steel..... 178*
 Lighting fixtures, Northern Pacific... 522*
 Lighting generators, underframe sus- pension of, safety..... 257*
 Lighting, M. C. B. convention..... 1386*
 Passenger, Dead weight in..... 210‡
 Passenger, Electric lighting of..... 620
 Passenger, Roof construction for, John- son..... 485*
 Refrigerator brine tank drain valve, Bourell..... 261*
 Reinforced wooden, Settlement prices for, M. C. B. convention..... 1344
 Repairs, Compensation for, M. C. B. convention..... 1343
 Repairs, Economics in freight..... 129
 Repairs, Improper charges for..... 1324‡
 Riveting in steel, construction..... 2‡
 Riveting in steel, construction, by H. A. Hatfield..... 87*
 Roofs, Testing, Santa Fe..... 339*
 Sand blasting steel, Mott Sand Blast- ing Mfg. Co..... 427*
 Sleepers, The ventilation of, by Thomas R. Crowder..... 464*
 Stakes, Form for bending steel, Black- smiths' convention..... 480*
 Standard box—a negative viewpoint... 121
 Steel baggage and mail, Jersey Central Steel box, Canadian Pacific..... 309*
 Steel, design from a protection stand- point, Painters' convention..... 540
 Steel, design from a protection stand- point, by John D. Wright..... 525
 Steel frame box, for the I. C..... 78*
 Steel frame passenger..... 157‡
 Steel freight competition..... 493‡
 Steel, Interior finish, Painters' conven- tion..... 541
 Steel passenger..... 1323‡
 Steel passenger with arch roof, Union Pacific..... 349*
 Steel pasenger, Design of..... 459*, 515*
 Steel passenger, Northern Pacific..... 517*
 Steel passenger, for the Santa Fe... 21*
 Steel passenger statistics..... 299
 Steel passenger, type of center sills in Steel, Sand blasting, American En- gineering Co..... 376*
 Steel suburban, Erie..... 356*
 Steel suburban, Long Island..... 402*
 Steel underframe box, Union Pacific Step, Adjustable, James H. Vaughan.. 546*
 Stock, End construction of Canadian Pacific..... 29*
 Suburban, Grand Trunk..... 174*
 Tank, M. C. B. convention..... 1377
 Truck (see Truck)..... 25*
 Underframe, Erie caboose..... 25*
 Underframe, Jersey Central steel bag- gage and mail cars..... 123*

Page numbers under 1,000 refer to Railway Age Gazette, Mechanical Edition; those over 1,000 refer to the Daily Railway Age Gazette. *Illustrated article; †editorial; ‡short non-illustrated article or note; †communication.

Car—(Continued)

Underframe, Northern Pacific steel passenger cars 517*
 Underframe, Santa Fe 22*
 Underframe, should be strengthened.. 330*
 Underframe, Strengthening 498†
 Vestibule trap door, Extensible, Pennsylvania 430*
 Vestibule trap door, Sliding, O. M. Edwards Co., Inc. 1320*
 Well, 200,000-lb. capacity, P. & L. E. Wheels (see Wheels) 397*
 Car control, by James Fitzmorris..... 71
 Car department association, A. 496‡
 Car department competition, A. 384‡
 Car department correspondence 55‡
 Car department correspondence and reports, by Charles Claudy..... 72
 Car department and expediting preferred freight 516
 Car department and increased earnings.. 1355‡
 Car department officers and economy..... 330‡
 Car department, Steel freight competition Car inspector: "The Doctor of Cars"..... 554‡
 Car inspector, Making a 576
 Car inspector problem, The..... 604‡
 Car inspectors 1307‡
 Car inspectors, Making good, by C. S. Taylor Car inspectors, Why it is hard to get good.. 624
 Car Inspectors' and Car Foremen's Association (see Chief Interchange Car Inspectors' and Car Foremen's Association).
 Car inspectors' competition, The, 439‡, 495‡, 555‡
 Car inspectors' competition, Prize article, A. M. Orr..... 575
 Car inspectors, The making of good..... 575
 Car man, The shipper, the railway and the, by F. C. Macgley 293*
 Car men, Of interest to 440‡
 Car repair facilities, Provide good..... 1383‡
 Car repair shops, Joint..... 1383‡
 Car repair shops, Joint, at large terminals, by F. C. Schultz 30
 Carpets, Cleaning, at terminals..... 475
 Caschardening, Blacksmiths' convention... 148†
 Caschardening materials 216†
 Cast iron, Machinery 308†
 Cast iron, Strength of 308†
 Castle nuts, Dies for forging large, Tool Foremen's convention 412*
 Catalogs 54, 104, 650
 154, 208, 266, 328, 382, 438, 494, 552, 602,
 Center sills, Considerations affecting type in steel passenger cars, by L. K. Sillcox. 227*
 Central of Georgia, Chuck for finishing boiler check bodies 133*
 Central of Georgia, Chucks for air pump repairs 183*
 Central of Georgia, Clips for date tags on steam gages and safety valves 131*
 Central of Georgia, Finishing tank valve castings 82*
 Central of Georgia, Special chucks for a turret lathe 196*
 Central of Georgia, Turning engine bolts.. 193*
 Central Railroad Club (see Meetings).
 Central Railroad of New Jersey, Freight car repair shops 62*
 Central Railroad of New Jersey, Steel baggage and mail cars 123*
 Chairs, Dining car 300*
 Charts, Calibration, for Vanderbilt tenders, by Towson Price 563*
 Chesapeake & Ohio, Boring and facing back main rod brasses and driving boxes..... 239*
 Chesapeake & Ohio, Oiling air pump air cylinders 408*
 Chesapeake & Ohio, Quadruple tool for planing shoes and wedges 584*
 Chesapeake & Ohio, Reclaiming material at local shops 631*
 Chesapeake & Ohio, Removing indentations in superheater smoke tubes 40*
 Chicago, Burlington & Quincy, Cleaning triple valves 568*
 Chicago, Burlington & Quincy, Handling coupler yokes 592*
 Chicago, Burlington & Quincy, Pneumatic hammer 586*
 Chicago, Indianapolis & Louisville, Locomotive coal consumption tests 617*
 Chicago and North Western, Bell yoke bearing reamers 36*
 Chicago & North Western, Device for placing air pumps 581*
 Chicago & North Western, Gas brazing furnace 591*
 Chicago & North Western, Method of cleaning air pumps 82*
 Chicago & North Western, Method of securing steam gages 364*
 Chicago & North Western, Packing iron for journal boxes 137*
 Chicago & Northwestern, Portable rivet forge and blow torch 191*
 Chicago & Northwestern, Pneumatic flue cutter 86*
 Chicago Pneumatic Tool Co., Flat plate air compressor valve 545*
 Chicago, Rock Island & Pacific, High speed steel tipped tools 590*
 Chicago, St. Paul, Minneapolis & Omaha, Repairing driving boxes 527*
 Chicago & Western Indiana, Cleaning carpets at terminals 567*
 Chicago & Western Indiana, Thawing out frozen cars 574*

Chief Interchange Car Inspectors' and Car Foremen's Association convention..... 522
 Chief Interchange Car Inspectors' and Car Foremen's Association (see Meetings).
 Chiles, Geo. S., Characteristics of plate springs 161*, 219*, 340*, 392*
 Chilled Car Wheel Manufacturers' Association (see Meetings).
 Christy Universal Pipe Joint Co., Pipe joint Cincinnati, Abatement of locomotive smoke at, by G. H. Funk 566*
 Cincinnati Electric Tool Co., Electric reamer 199*
 Cincinnati, New Orleans & Texas Pacific, Grinding distributing valves 39*
 Cincinnati Planer Co., Slide plate planer.. 95*
 Clark, W. A., Lubrication of car journals.. 19
 Claudy, Charles, Car department correspondence and reports..... 72
 Clifton, W. H., Substitutes for expensive lumber 288
 Cline, N. T., Air pump gland nut lock..... 322*
 Coal consumption, Locomotive, by L. W. Wallace 617*
 Coal dust, Ignition temperature of..... 642†
 Coal, Powdered, Fuel convention..... 271
 Coal preparation, Standardization of, Fuel convention 275
 Coal, Pulverized, for locomotives..... 213‡
 Coal pusher, Locomotive Stoker Co..... 1321*
 Coal, Saving, by Charles Maier..... 442†
 Coal sprinkler, Ohio Injector Co..... 256*
 Coaling facilities, Improved performance with old type, by J. S. Williams..... 66*
 Coaling stations, Fire hazards at 562
 Coaling stations, Fuel convention..... 275*
 Cole, F. J., Boiler design in respect to heating surface, at A. S. M. E. 5
 Color, Flat, vs. enamel, Painters' convention
 Combustion in locomotive fireboxes, by J. T. Anthony, at A. S. M. E. 10
 Combustion in locomotive fireboxes, by J. P. Neff, at A. S. M. E. 10
 Committee report, A, well presented.. 1267‡
 Commutators, Turning, in the power house. 470*
 Competition, The apprentice letter..... 496‡
 Competition, Boiler inspection..... 439‡, 496‡, 384‡
 Competition, A car department..... 555‡
 Competition, The car inspectors' 439‡, 495‡, 555‡
 Competition, Don't miss this..... 603‡
 Competition, Locomotive boiler inspection.. 604‡
 Competition, Piston valve packing ring... 439‡
 Competition, Piston valve ring..... 534‡
 Competition, Steel freight car..... 495‡, 554‡
 Competition, A unique 554‡
 Compressed air, The cost of, by Thomas F. Crawford 364
 Condenser, Vacuum pump, Ingersoll-Rand. Consolidation of mechanical associations..... 330‡
 Consolidation, The, problem 1356‡
 Control of cars, by James Fitzmorris..... 71
 Convention Hall, The New, at Atlantic City 1183‡
 Conventions, The July 383‡
 Conventions, Two July 329‡
 Conventions, Two successful 1356‡
 Copper and alloys, Welding by acetylene methods, by J. F. Springer 367
 Cordeal, Ernest, Locomotive running repairs 37
 Cornell, Harry, Laying out Southern valve gear 3861*
 Correspondence, Car department..... 55‡
 Correspondence and reports, Car department, by Charles Claudy 72
 Cost of hiring and discharging men..... 1268‡
 Counterbalancing, M. C. B. convention... 1292
 Coupler, Automatic, with movable guard arm, Stark Car Coupler Corp. 1382*
 Coupler committee, The report of..... 1355‡
 Coupler, Gage for pilot, by H. C. Spicer... 216*
 Coupler head, Emergency, Frank B. Hart. Coupler release lever for switch engines, by Geo. E. McCoy..... 115*
 Coupler release rigging, Singlelink 486
 Coupler release rigging, Simple, National Railway Devices Co. 431*
 Coupler yokes, Handling, C. B. & Q. 592*
 Couplers, New M. C. B. experimental..... 622*
 Couplers, M. C. B. convention..... 1359*
 Couplers and parts, Marking of, Storekeepers' convention 290
 Couplings, Flange and screw, for injectors, M. M. convention 1300*
 Crane arrangement for locomotive shops... 372*
 Crane & Co., Locomotive safety valve..... 255*
 Crane motor, Standardization of 585
 Crane, Pillar, for machine tool work, Can. Nor. 360*
 Crane, Proposed Gantry for car repair yards, by W. E. Johnston 304*
 Crane trolley, Electric, Northern Engineering Works 97*
 Cranes, Safety limit stop for electric, Electric Controller & Mfg. Co. 1398*
 Crawford, D. F., President's address at M. C. B. convention 1327
 Crawford, Thomas F., Cost of compressed air 364
 Crosshead shoes, Jig for babbitting, Tool Foremen's convention 410*
 Crowder, Thomas R., Ventilation of sleeping cars 464*
 Crown sheets, Device for determining height of, Tool Foremen's convention 410*
 Crown sheets, Standard slope of, Boiler Makers' convention 314

Curtain rollers, Improved Rex..... 1352*
 Curtain Supply Co., Improved Rex curtain rollers..... 1352*
 Curtain Supply Co., Improvements to Rex diaphragm curtains..... 1382*
 Curtain Supply Co., Rex, metal diaphragms 1321*
 Curtis, Hobart W., Adjustable saw guard 95*
 Cut-out valve, Safety, Santa Fe..... 44*
 Cylinder cocks, Finishing..... 195*
 Cylinder heads, Attachment for grinding.. 133*
 Cylinders repaired by arc welding..... 477*

D

Daily, F. J., Index head for holding rod brasses 140*
 Damage to freight 1324‡
 Damage to lading, Prevention of..... 267‡
 Damascus Brake Beam Co., Forged brake beam fulcrum 144*
 Damascus Brake Beam Co., Solid forged brake beam fulcrum..... 1382*
 Davey, Dr. W. P., An X-ray inspection of a steel casting..... 170*
 Dearborn Steel & Iron Co., Belt shifter.. 543*
 De Laval Steam Turbine Co., High speed blower and centrifugal air compressor.. 374*
 Delaware, Lackawanna & Western, Water tube firebox..... 222*
 Delta Electric Co., Hand lantern..... 488*
 Derailments, causes and a remedy, by H. M. Perry 619*
 Design, American and European locomotive 1268‡
 Design, construction and inspection of locomotive boilers, M. M. convention..... 1272
 Design, Good features of tank 224*
 Design, Improved locomotive..... 440‡
 Design, Locomotive, for fuel economy, M. M. convention 1275
 Design of reciprocating and revolving parts 106‡
 Design of a standard M. C. B. box car, M. C. B. convention 1370*
 Design of steel passenger equipment, by Victor W. Zilen..... 459*, 515*, 625*
 Design, Practice versus theory in, by F. M. Brinckerhoff 108‡
 Design, Refinement in locomotive 331‡
 Design, Spring rigging, A study of, by J. P. Shamberger 15*
 Design, Steel car, from a protection standpoint, by John D. Wright 525
 Design, Steel car, from a protection standpoint, Painters' convention 540
 Detroit Lubricator Co., Automatic force feed flange oiler 1283*
 Diagram for determining percentage of maximum tractive effort, by L. R. Pomeroy 453*
 Diamond, The, in steel boring 20†
 Diaphragm curtains, Improvements to Rex. 1382*
 Diaphragm, Reverse unfold, Acme..... 1353*
 Diaphragms, Rex metal..... 1321*
 Dickert, C. L., Clips for date tags for steam gages and safety valves 131*
 Dickert, C. L., Turning engine bolts 193*
 Dies, Forging machine, by J. Lee..... 37*
 Disinfectant arrangement for passenger cars, Can. Nor. 466*
 Distributing valves, Grinding, C., N. O. & T. P. 39*
 Doctor of cars, The, by G. C. Slarow 628
 Door, End, for box car, by Geo. E. McCoy.. 173*
 Door, Flush box car, Ralston..... 1354*
 Doors, Box car 1355‡
 Doors, Specification for outside hung for new box cars, M. C. B. convention... 1368
 Draft arms, Wooden..... 1383‡
 Draft gear construction, M. C. B. convention 1369*
 Draft gear, M. C. B. convention 1390
 Draft gear problem, by E. A. Murray 498‡
 Draft rigging, Friction spring, Cambria Steel Co. 259*
 Drain fitting blower pipe, Watertown... 45*
 Drain valve, Exhaust passage, Can. Nor. 586*
 Drifting valve, Automatic, M., St. P. & S. S. M. 593*
 Drifting valve, Automatic, Nathan..... 372*
 Drill, Close quarter, Ingersoll-Rand... 1322*
 Drill device for firebox work, Tool Foremen's convention 412*
 Drill post, Angle, Tool Foremen's convention 409*
 Drill motor extensions by V. T. Kropidowski 579*
 Drill (see Machine tools).
 Drilling attachment, Horizontal, for a radial drill, by V. T. Kropidowski 40*
 Drilling stand, Adjustable 42*
 Drinking fountain, Sanitary, for passenger cars, Henry Giessel & Co. 47*
 Driving box brasses, Jig for setting up in shaper, by Lewis Lebovitz 370*
 Driving box wedge, Automatic, Franklin.. 546*
 Driving boxes, Boring and facing, by M. Flanagan 239*
 Driving boxes, Machine for boring, by E. C. Gaines 138*
 Driving boxes, Repairing, by P. F. Smith. 527*
 Driving wheel hub-plate, Adjustable, Smith. 486*
 Drop forging, Blacksmiths' convention... 476*
 Drop handle and ratchet, Brake shaft.... 43*
 Dry kiln, Norfolk & Western, humidity controlled, by W. H. Lewis 462*
 Dry pipe collars, Jig for drilling, by F. W. Bentley, Jr. 81*

Page numbers under 1,000 refer to *Railway Age Gazette, Mechanical Edition*; those over 1,000 refer to the *Daily Railway Age Gazette*. *Illustrated article; †editorial; ‡short non-illustrated article or note; † communication.

Dry pipe joints, Jig for grinding, Tool Foremen's convention..... 411*
 Duffey, Paul R., Water gage cocks..... 136*
 Dynamometer car, Japanese railways, by Edward C. Schmidt..... 66*
 Dynamometer car, Swiss railways..... 606*

E

Eccentric cranks, Tool for locating, Tool Foremen's convention..... 410*
 Eccentrics, Jig for planing..... 188*
 Economy, Car department officers and..... 330*
 Economy Devices Corp., Radial buffer..... 1322*
 Economy Devices Corp., Piston valves applied to slide valve cylinders..... 258*
 Economy Devices Corp., Rectangular exhaust nozzle..... 1192*
 Economy Devices Corp., Universal valve chest..... 1282*
 Economy, Enginemmen and..... 24
 Economy, The, of good workmanship..... 156*
 Education of locomotive firemen..... 496*
 Edwards Co., Inc., O. M., Sliding vestibule trap door..... 1320*
 Efficiency engineer, An experience with the, by Harvey De Witt Wolcomb..... 639
 Efficiency, Engine house, General Foremen's convention..... 423*
 Efficiency, Machine tool..... 24
 Efficiency, Measuring, by H. L. Gantt..... 249
 Efficiency in railroad shops..... 603*
 Efficiency, Relative, of steam, gas and oil engines..... 170*
 Efficiency, Shop, by Robert N. Miller..... 137
 Efficiency, Shop, General Foremen's convention..... 421
 Ejector, Squirt hose, Ohio Injector Co..... 256*
 Electric Controller & Mfg. Co., Safety limit stop for electric cranes..... 1398*
 Electric furnace for reheating, heat treating and annealing, by T. F. Bailey..... 481
 Electric furnace, Tempering tools with the Electric hand lantern, Delta..... 488*
 Electric headlight equipment, Sou. Pac. six-volt..... 613*
 Electric headlight, Incandescent equipment, Pyle..... 1199*
 Electric lighting of passenger cars..... 620
 Electric lighting system, Car..... 467
 Electric process for safe-ending tubes, by L. R. Pomeroy..... 469*
 Electric reamer, Cincinnati Electric Tool Co. Electric welding (see Arc welding).
 Electrical equipment, Maintenance and operation of, M. M. convention..... 1294
 Electrical operation, Steam railway men and Electro-pneumatic brake, T. E. A. convention Elfe, W. W., Chuck for finishing boiler check bodies..... 133*
 Elfe, W. W., Chuck for air pump repairs..... 183*
 Elfe, W. W., Finishing tank valve castings..... 82*
 Elfe, W. W., Special chucks for a turret lathe..... 196*
 Elliott, Edward O., Brake beam safety hanger..... 431*
 Emerson, Harrington, Analysis of dependent sequence as a guide to fuel economies..... 273
 Enamel color, Flat color vs., Painters' convention..... 540
 Enamel color, Maintenance of, versus varnish, Painters' convention..... 541
 Endsley, L. E., Experiments to determine stresses in truck side frames..... 127*
 Endsley, L. E., Impact between cars in switching service, M. C. B. convention..... 1391*
 Engine bolts, Turning, by C. L. Dickert..... 193*
 Engine failures..... 442*
 Engine failures, Prevention of..... 385*
 Engine failures, Relation of engine house organization to, by Harvey De Witt Wolcomb..... 533
 Engine failures, their cause and cure, by J. E. Anderson..... 587
 Engine, High compression oil, Nordberg..... 487*
 Engine house efficiency, General Foremen's convention..... 423*
 Engine house foremen, Training..... 81
 Engine house organization..... 135*
 Engine house repair work, by M. Vallen..... 85
 Engine house, Suggestions for a properly kept, by W. U. Appleton..... 187
 Engine house work, Best practices in..... 139
 Engine houses, Handling locomotives at..... 156*
 Engine terminal, Getting results from a big Engineers' Society of Western Pennsylvania (see Meetings).
 Enginemmen and economy..... 24
 Enginemmen, Educating in smoke elimination..... 216
 Engineering Foundation, The (see Meetings)
 Engineers' and firemen's demands, Western. Ennis, J. B., Possibilities of the future, A. S. M. E..... 14
 Equipment, Dead weight in passenger..... 210*
 Equipment, Government inspection of railway..... 209*
 Equipment, Proper handling of, by E. E. Betts..... 629
 Equipment, Steel frame passenger..... 157*
 Equipment, Steel passenger train..... 299
 Erie Railroad, Caboose with steel center sills..... 25*
 Erie Railroad, Combination rivet set..... 251*
 Erie Railroad, Heavy 2-10-2 type locomotive..... 158*
 Erie Railroad, Jig for planing eccentrics..... 188*

Erie Railroad, Model locomotives built by apprentices..... 41*
 Erie Railroad, Steel suburban cars..... 356*
 Erie Railroad, Turning commutators in the power house..... 470*
 Exhaust nozzle, Rectangular, Economy..... 1192*
 Exhaust nozzle, Variable, F. Mertsheimer..... 1319*
 Exhaust nozzle with internal projection..... 198*
 Exhausts, Variable, by J. Snowden Bell, M. M. convention..... 1290*
 Exhibit, Railway Supply Manufacturers' Association at Atlantic City..... 1200*
 Exhibit, This year's..... 1183*
 Exhibit, Track, at Atlantic City..... 1311
 Exhibitors, With the..... 1308*
 Expansion joint for water heater..... 628*
 Extension cord plugs, Post cluster for, by F. W. Bentley, Jr..... 192*
 Eye protectors for machinists and grinders, T. A. Willson & Co..... 48

F

Facing tool, Automatic, Mummert-Dixon..... 48*
 Fan, Ceiling, Safety..... 1352*
 Fan drafting as applied to locomotives, by H. B. MacFarland, at A. S. M. E..... 6*
 Feed water, Treating locomotive, Boiler Makers' convention..... 314
 Feed water heater on geared locomotive, by Harold S. Johnson..... 226*
 Feed water heating, by H. H. Vaughan, at A. S. M. E..... 12
 Feed valve testing clamp, by B. N. Lewis..... 134*
 Filter, oil, Richardson-Phenix Co..... 253*
 Fire hazards at coaling stations..... 562
 Fire losses in the mechanical department..... 554*
 Firebox crown sheet, Standard slope of, Boiler Makers' convention..... 314
 Firebox, Riegel water tube..... 222*
 Firebox sheets, Movement of..... 1267*
 Fireboxes, Cross stays in, Boiler Makers' convention..... 314
 Fireboxes, Removing and replacing, Boiler Makers' convention..... 316
 Fire door latches, Chucks for threading in a turret lathe..... 196*
 Fire door pedal, Adjustable, Franklin..... 144*
 Firemen, Education of locomotive..... 496*
 Firemen, Performance of..... 346*
 Firemen, Training, T. E. A. convention..... 508
 Firing, Smokeless, and passenger revenue. Fitzmorris, James, Car control..... 71
 Flanagan, M., Boring and facing main rod brasses and driving boxes..... 239*
 Flange oiler, Automatic force feed, Detroit..... 1283*
 Flanging clamp, Pneumatic, Niles-Bement-Pond Co..... 145*
 Flaws, Locating, in metal surfaces..... 642*
 Flue cutter, Pneumatic..... 86*
 Flues (see Boiler tubes)
 Foremen, Developing car..... 1384*
 Foremen, The training of..... 55*
 Foremen, Training engine house, by R. G. Gilbride..... 81
 Forge, Oil burning blacksmith..... 633*
 Forge, Portable rivet and blow torch, by W. S. Whitford..... 191*
 Forge, Portable rivet, Mahr Mfg. Co..... 1283*
 Forging, Drop, Blacksmiths' convention..... 476*
 Forging hammer, Pneumatic light, H. Edsil Barr..... 147*
 Forging machine dies, by J. Lee..... 37*
 Forging specifications, M. M. convention..... 1296
 Forms for handling work reports at engine houses..... 31*
 Fossdick Machine Co., High speed radial drill..... 595*
 Foundry and Machine Exhibition (see Meetings)
 Fowler, Geo. L., Tests of exhaust ventilators Franey, M. D., New York Central smoke-washing plant..... 511*
 Franklin Institute (see Meetings)
 Franklin Railway Supply Co., Adjustable fire door pedal..... 144*
 Franklin Railway Supply Co., Automatic driving box wedge..... 546*
 Franklin Railway Supply Co., Hard grease press..... 322*
 Franklin Railway Supply Co., Main reservoir ball joint connection..... 254*
 Franklin Railway Supply Co., Single locomotive water joint..... 201*
 Freight, Car department and expediting preferred..... 516
 Freight, Loss and damage to..... 1324*
 Frogs and crossings, Making and repairing, Blacksmiths' convention..... 471
 Front end conditions, Road tests for determining, by E. S. Barnum..... 454*
 Front end and draft appliances, Locomotive, by C. D. Young at A. S. M. E..... 9
 Front ends, Fuel convention..... 281
 Fry, Lawford H., Compounding superheater locomotives, M. M. convention..... 1220
 Fuel Association (see also International Railway Fuel Association)
 Fuel convention, Railway..... 268*
 Fuel economy, Locomotive..... 1268*
 Fuel economy, M. M. convention..... 1275
 Fuel economies, Analysis of dependent sequence as a guide to, Fuel convention..... 273
 Fuel, Pulverized, for locomotives..... 211*
 Fuel stations, Fuel convention..... 275*
 Funk, G. H., Abatement of smoke in Cincinnati..... 566

Furnace, Gas brazing, C. & N. W..... 591*
 Furnace, Simple, for melting brass..... 36*

G

Gage for pilot coupler, by H. C. Spicer..... 216*
 Gages, Wheelpress and locomotive..... 1285*
 Gaines, E. C., Machine for boring driving boxes..... 138*
 Gaines, F. F., Feed water heating, A. S. M. E..... 12
 Gaines, F. F., President's address at M. M. convention..... 1211*
 Gamble, H. E., The best methods of dealing with men..... 61
 Gantt, H. L., Measuring Efficiency..... 249
 Gardner, Henry H., Prepared paints for metal surfaces..... 513
 Gardner, Henry, Railway repair shop organization..... 536*
 Gas valve, A high pressure, International Oxygen Co..... 44*
 Gaskets, Reinforced asbestos, for air pump cylinder heads, by J. A. Jesson..... 469*
 Gear case, Seamless drawn steel..... 1226*
 General Foremen's Association (see International Railway General Foremen's Association)
 Gibbons, J. W., Protection of iron and steel..... 580*
 Giessel & Co., Henry, Sanitary drinking fountain for passenger cars..... 47*
 Gilbride, R. G., Training engine house foremen..... 81
 Gillespie, W. J., Article in boiler inspection competition..... 636
 Givin, E. F., Eight-wheel caboose with steel underframe..... 231*
 Golden-Anderson Valve Specialty Co., Automatic non-return valve..... 596*
 Goodwin, Geo. S., Economic value of a locomotive..... 118
 Goodyear Tire & Rubber Co., Air brake hose..... 484*
 Grady, Benjamin, Repairing 9/2-in. air pump cylinder heads..... 530*
 Grain, Saving waste..... 294*
 Grand Trunk suburban coaches..... 174*
 Grate, Hulson locomotive..... 431*
 Grates, Fuel convention..... 281
 Grease cups, Compressed air, Hunter..... 645*
 Grease press, Franklin Railway Supply Co. 322*
 Great Northern, Device for forming sill steps..... 641*
 Great Northern, Reclamation plant..... 305*
 Greenfield Tap & Die Corporation, Internal guide for pipe threading tools..... 261*
 Grider, Portable, Ingersoll-Rand..... 1286*
 Grinding and distribution of tools, Tool Foremen's convention..... 415
 Grinding machines (see Machine Tools)
 Grinding wheel protection, by E. T. Spidy..... 249*
 Grinding wheel wear, Effect of speed on..... 386*
 Grinding wheels..... 48*
 Guide bars, Jigs for grinding..... 242*
 Guides, Turret head for planing, by B. O. Yearwood..... 187*
 Gustin-Bacon Mfg. Co., Vacuum oil burner..... 260*
 Gustin-Bacon Mfg. Co., Vacuum paint sprayer..... 98*

H

Hack saw (see Machine Tools)
 Hammer, Motor drive for Bradley helve, by W. E. Johnson..... 184*
 Hammer, Motor driven power, Beaudry..... 319*
 Hammer, Pneumatic light forging, H. Edsil Barr..... 147*
 Hammett, H. G., Expanding and beading machine for injector pipe couplings..... 1282*
 Hanger, Brake beam safety, E. O. Elliott..... 431*
 Hanna Engineering Works, Riveting machine..... 547*
 Hardening tool steel, Factors in, by J. A. Mathews, et al..... 243*
 Hardness testing..... 115*
 Harrigan, J. H., Why it is hard to get good car inspectors..... 627
 Harrison Safety Boiler Works, Recorder for measuring flow over weirs..... 433*
 Hart, Frank B., Emergency coupler head..... 484*
 Harvey, H. H., Economics in freight car repairs..... 129
 Hatfield, H. A., Riveting in steel car construction..... 33*
 Headlight, Incandescent, Pyle..... 1199*
 Headlights, Locomotive, M. M. convention..... 1270*
 Headlight requirements, Locomotive, by E. S. Pearce..... 451*
 Headlight, Sou. Pac. six-volt electric, equipment..... 613*
 Heat treated and alloy steels, by C. D. Young, at A. S. M. E..... 13
 Heat treating, The electric furnace for, by F. F. Bailly..... 481
 Heat treatment of metal, Blacksmiths' convention..... 480
 Heat treatment of steel..... 210*
 Hedeman, Walter R., Good features of tank design..... 224*
 Heffelfinger, H., Piece work for a paint shop..... 526
 Helmet, Sand blast, J. M. Betton..... 146*
 Hettenbaugh, R. J., The apprentice school..... 633
 Hoist for loading scrap wheels..... 631*
 Hose, Air brake, Goodyear..... 484*

Page numbers under 1,000 refer to *Railway Age Gazette, Mechanical Edition*; those over 1,000 refer to the *Daily Railway Age Gazette*. *Illustrated article; † editorial; ‡ short non-illustrated article or note; § communication.

Hose connectors, automatic, Service tests of 46†
 Hose clamp, Safety, Mahr Mfg. Co. 145*
 Hose coupling, National 432*
 Hub plate, Smith adjustable 486*
 Hulson Grate Co., locomotive grate 431*
 Hunter Pressed Steel Co., Compressed air grease cup 645*
 Huntley, W. P., Engine house organization 135*
 Hydraulic Press Mfg. Co., Pipe bender 142*
 Hydraulic Press Mfg. Co., Small triplex pump 197*
 Hydraulic press, Portable attachment for operating, by B. N. Lewis 134*

I

Illinois Central, Steel frame box car 78*
 Illinois Central tool system, by Owen D. Kinsey 361*
 Impact between cars in switching service, L. E. Endsley, M. C. B. convention 1391*
 Imperial Brass Mfg. Co., Oxy-acetylene equipment 197*
 Imperial Brass Mfg. Co., Oxy-acetylene welding and cutting torch 320*
 Indicator reducing motion, by Hugh G. Boutell 56‡
 Ingersoll-Rand Co., Close quarter drill 1322*
 Ingersoll-Rand Co., Condenser vacuum pump 594*
 Ingersoll-Rand Co., Piston valve with automatic cut-off for air compressors 643*
 Ingersoll-Rand Co., Portable grinder 1286*
 Ingersoll-Rand Co., Small air compressor 428*
 Injector pipe couplings, Expanding and beading machine for, H. G. Hammett 1282*
 Injectors, Exhaust, by Robert W. Rogers 514*
 Injectors, Exhaust steam, for locomotives 205†
 Injectors, Flange and screw couplings for, M. M. convention 1300*
 Inspecting boilers, A few facts about 365
 Inspection and maintenance of air brakes on freight cars, by Robert Barnaby 406
 Inspection, Freight car 440‡
 Inspection, Government, of railway equipment 209‡
 Inspection, Locomotive boiler 308
 Inspection, Locomotive boiler, competition 604‡
 Inspection of locomotives and tenders 284
 Inspection, Overhead, of box cars, M. C. B. convention 1367
 Inspection, Uniformity in car, by M. Marea 468
 Instruments for measuring the hardness and elasticity of rubber, Shore 374*
 Interchange Car Inspectors' and Car Foremen's Association (see Chief Interchange Car Inspectors' and Car Foremen's Association)
 Interchange, Discussion of rules of, Car Inspectors' convention 524
 Interchange service, Eliminate old equipment from 496‡
 Interchange, Trifling defects in, Car Inspectors' convention 523
 Interchange, M. C. B. rules of 1323‡
 Interchange, Revision of the rules of, M. C. B. convention 1340
 International Association for the Prevention of Smoke 491
 International Engineering Congress (see Meetings)
 International Oxygen Company, A high pressure gas valve 44*
 International Railroad Master Blacksmiths' Association convention 471*
 International Railroad Master Blacksmiths' Association (see Meetings)
 International Railway Fuel Association 271*
 International Railway General Foremen's Association convention 417*
 International Railway General Foremen's Association (see Meetings)
 Investigator, A field for the special 604‡

J

Jack, Emergency, with adjustable base, Simplex 432*
 Jack, Parsons Journal 488*
 Jacks, Emergency, Buckeye 259*
 James, W. F., Stenciling gage for freight cars 468*
 Japanese Railways, Dynamometer car 66*
 Jenkins Bros., Swing check valve 1286*
 Jerome-Edwards Metallic Packing Co., Sullivan piston and valve stem packing 596*
 Jesson, J. A., Care of lye tanks 188*
 Jesson, J. A., Reboiling air pump cylinders 138*
 Jesson, J. A., Reinforced gaskets for air pump cylinder heads 469*
 Jesson, J. A., Repairing worn air pump reversing rods 242*
 Jesson, J. A., Removing gaskets from bulls-eye lubricators 39*
 Jigs, Special, for locomotive repair shops, Tool Foremen's convention 409*
 Johns-Manville Co., H. W., Slack adjuster for brake equipment 1319*
 Johns-Manville Co., H. W., Manual slack adjuster for freight cars 644*
 Johnson, Harold S., Feed water heater on geared locomotive 226*
 Johnson, Otto B., Roof construction for passenger cars 485*
 Johnson, W. E., Cleaning air pumps 82*
 Johnson, W. E., Packing iron for journal boxes 137*

Johnston, W. E., Motor drive for Bradley helve hammer 184*
 Johnston, W. E., Proposed Gantry crane for car repair yards 304*
 Journal bearing, Brake hanging and the M. C. B. 270‡
 Journal bearing, Roller, Anti-Friction Roller Bearing Co. 141*
 Journal bearings, Bronze, The American Metal Co. 48†
 Journal bearings, Hot trailer 565*
 Journal box packing guard, Nuway Packing Guard Co. 200*
 Journal brasses, Finishing car and engine truck by grinding, by R. E. Brown 193*
 Journal jack, Parsons 488*
 Journals, Maintenance of car 1307‡
 June Mechanical Conventions... (See Meetings)

K

Kansas City, Mexico & Orient, Variable exhaust nozzle 1319*
 Keystone Equipment Co., Tool holder for high speed steel cutters 1226*
 Kiesel, W. F., Jr., Stresses in side rods 212‡
 Kingan-Ripken Co., Valve gear device 483*
 Kinsey, Owen D., Illinois Central tool system 361*
 Kinsey, Owen D., Machine steel for small tools 189*
 Kropidowski, V. T., Drill motor extensions 579*
 Kropidowski, V. T., Horizontal drilling attachment for a radial drill 40*
 Kropidowski, V. T., Reducing piston valve leakage 359*

L

Labor and material, Prices for, M. C. B. convention 1343
 Ladders, Device to prevent slipping of, Mason 1285*
 Landis Machine Co., Chaser grinder 47*
 Landis Machine Co., Pipe threading and cutting machine 429*
 Lantern, Electric hand, Delta 488*
 Lauer, W. F., Piston valve packing rings 583*
 Lebovitz, Lewis, Flue cutter 542*
 Lebovitz, Lewis, Jig for setting up crown brasses in shaper 370*
 Lee, J., Forging machine dies 37*
 Leigh Valley, Closing valve links with oxy-acetylene torch 538*
 Letters, The apprentice 439‡
 Lewis, B. N., Manufacturing brooms 407*
 Lewis, B. N., Shop notes from the Soo Line 133*
 Lewis, W. H., Humidity controlled dry kiln 462*
 Lifting hook for heavy work 133*
 Lighting arrangement, Northern Pacific steel coaches 522*
 Lighting system, Car electric 467
 Lighting, Train, M. C. B. convention 1386*
 Lillie, G. W., Tender Derailments 58‡
 Lincoln Electric Co., Constant current welder 490*
 Lincoln, J. F., Answers to some questions on arc welding 195
 Lineshaft, Higher speeds 516†
 Lister, F. G., Oil-burning blacksmith forge 633*
 Lister, F. G., Oil burning sand dryer 407*
 Loading, Improper, of box cars 233
 Loading rules, M. C. B. convention 1366*

Locomotives

2-10-2 Erie 158*
 4-4-4 type, P. & R. 1193*
 4-6-0, Portuguese State Railways 116*
 4-6-2 type, Santa Fe 217*
 4-8-2 type, Can. Pac. 556*
 Alterations in, to increase capacity 105‡
 American and European design 1268‡
 Ash pans, Fuel convention 281
 Boilers, Design, construction and inspection of, M. M. convention 1272
 Boiler inspection 308
 Buffer, Radial, Economy Devices Corp. 1322*
 Capacity, Increased, in existing 1‡
 Coal consumption, by L. W. Wallace 617*
 Coal pusher, Locomotive Stoker Co. 1321*
 Counterbalancing, M. M. convention 1292
 Crankpins, General Foremen's convention 420
 Cylinder lubricator, force feed, Nathan 480*
 Cylinders, Repairing by arc welding 477*
 Design of, for fuel economy, M. M. convention 1275
 Design, Improved 440‡
 Design, Refinement in 331‡
 Development in 1914 2‡
 Driving axles, General Foremen's convention 420
 Driving boxes (see driving boxes)
 Driving spring hangers, Dies for forming 476*
 Economic value of a, by Geo. S. Goodwin 118
 Operation, Effect of valve gear on, T. E. A. convention 505*
 Exhaust nozzle with internal projections 198*
 Exhaust nozzle, Rectangular, economy 1192*
 Exhaust nozzle, Variable 1319*
 Exhaust nozzle, variable, M. M. convention 1290*

Locomotives—(Continued)

Fan drafting as applied to, by H. B. MacFarland, at A. S. M. E. 6*
 Fashions in 210‡
 Feed water heating, by F. F. Gaines, at A. S. M. E. 12
 Firebox, Lackawanna water tube 222*
 Fireboxes, Combustion in, by J. T. Anthony, at A. S. M. E. 10
 Fireboxes, Combustion in, by J. P. Neff, at A. S. M. E. 10
 Frame construction, P. & R., 4-4-4 type 1195*
 Frame, Method of arc welding 477*
 Front end and draft appliances, by C. D. Young, at A. S. M. E. 9
 Front ends, Fuel convention 281
 Grates, Hulson convention 431*
 Grates, Fuel convention 281
 Headlight requirements 451*
 Inspection of 284
 Link trunnion, Dies for forming 476*
 Maintenance, Some factors in 140
 Mileage account 440‡
 Mikado vs. Consolidation, by N. D. Ballantine 615
 Model, built by Erie apprentices 41*
 Modern appliances on, T. E. A. convention 499*
 Operation, Smokeless, without special apparatus, H. H. Maxfield 561
 Performance, Variations in 240†
 Pistons, Forged and rolled steel, by W. W. Scott, Jr. 343*
 Possibilities of the future, by J. B. Ennis, at A. S. M. E. 14
 Radius bar, Length of, by L. R. Pomeroy 290*
 Reading type 1184‡
 Reciprocating parts, Light 1288‡
 Reciprocating and revolving parts, by H. A. F. Campbell 443*
 109*, 163*, 215, 390*, 443*
 Reverse gear, Can. Pac., 4-8-2 type 560*
 Reverse gear, Young 1284*
 Rod brasses, Boring and facing back main, C. & O. 239*
 Rods, tires and wheels, General Foremen's convention 420
 Running repairs 41
 Running repairs, by Ernest Cordeau 37
 Sander, White 1353*
 Side rods, Stresses in 212‡
 Spring rigging design, A study of, by J. P. Shamberger 15*
 The steam, of today, Discussion, A. S. M. E. 5
 Steam tender, Southern Ry. 613*
 Stokers, Fuel association 277
 Stokers, M. M. convention 1214*
 Superheater, Compounding 1267‡
 Superheater, Compounding, M. M. convention 1220
 Superheaters, by G. L. Bourne, at A. S. M. E. 12*
 Tabular comparison, 2-8-2 type 339
 Tabular comparison of 4-4-2, 4-6-0, 4-4-0, 2-6-0 and switching types 396
 Tabular comparisons, 4-8-2 and 4-6-2 types 338
 Tabular comparison of Mallet, 2-10-2 and 2-8-0 types 292
 Truck, Canadian Pacific, 4-8-2 type 558*
 Uniflow cylinder for 612*
 Valve gear, Southern, by R. S. Mounce 59*
 Valve gear, Young 1284*
 Water joint, Single, Franklin 201*
 Wedge bolt, removable 200*
 What the stoker has done for the, by E. A. Averill, at A. S. M. E. 11
 What the stoker has done for the, by C. F. Street, at A. S. M. E. 11
 Locomotive Stoker Co., Coal pusher 1321*
 Locomotive, The value of the 107‡
 Long Island Railroad, Shop kinks, Blacksmiths' convention 480*
 Long Island steel suburban cars 402*
 Loss and damage to freight 1324‡
 Loucks, H. L., Combination rivet set 251*
 Loucks, H. L., Jig for planing eccentrics 188*
 Loucks, H. L., Points for apprentices to ponder 132
 Loucks, H. L., Turning commutators in the power house 470*
 Louisville & Nashville, Removing gaskets from bulls-eye lubricators 39*
 Louisville & Nashville, Testing devices for air brakes 470*
 Lubricants, Tests of, by H. M. Baxter 225
 Lubricating Metal Co., Metallic packing material 1286†
 Lubrication of car journals 19
 Lubricator choke plugs, Reclaiming worn 252*
 Lubricator, Double action force feed, Nathan 489*
 Lubricators, bulls-eye, Removing gaskets from, by J. A. Jesson 39*
 Lumber, Ordering and handling 574
 Lumber, Scrap, from box cars 1323‡
 Lumber, Substitutes for expensive, Storekeepers' convention 288
 Lye tanks, Care of, by J. A. Jesson 188*

M

Ma-Corkindale, A., Take a real interest in the apprentice 641

Page numbers under 1,000 refer to *Railway Age Gazette, Mechanical Edition*; those over 1,000 refer to the *Daily Railway Age Gazette*. *Illustrated article; †editorial; ‡short non-illustrated article or note; ‡communication.

MacFarland, H. B., Fan drafting as applied to locomotives at A. S. M. E. 6*

McCoy, Geo. E., Adjustable drilling stand 42*

McCoy, Geo. E., Box car end door. 173*

McCoy, Geo. E., Uncoupling lever for switch engines 115*

McIntosh, Peter E., Y-fitting for washing out boilers 530*

McIntosh, Peter E., Special beading tool and boiler patch bolt 137*

McManamy, Frank, Results of locomotive boiler inspection law 190

Machine Shop Management 331

Machine tool efficiency 28

Machine Tools

Band saw, Metal, Williamson 488*

Band saw, Vertical, for metal cutting, M. E. Shinn & Co. 142*

Boring and Turning Mill, Niles-Bement-Pond 543*

Car wheel lathe, Center drive 321*

Drill, Cotter and keyseat, Niles-Bement-Pond 486*

Drill, Radial, Willmarth 45*

Grinder, Car wheel, Springfield Manufacturing Co. 143*

Grinder, Chaser, Landis 47*

Grinding machine, Self-contained, modern 91*

Hack-saw machine, High speed, Massachusetts Saw Works 544*

Lathe, Driving wheel, Niles-Bement-Pond Co. 371*

Lathe, Portable, American 97*

Nut tapping machine, Automatic, National Machinery Co. 143*

Pipe threading and cutting machine, Landis Machine Co. 429*

Planer, Slide plate, Cincinnati 95*

Quintuple punch and shear, Ryerson 198*

Radial drill, High speed, Fosdick Machine Co. 505*

Slabbing machine, Vertical, Newton 319*

Turret lathe, Universal hollow-hexagon, Warner & Swasey 96*

Worm wheel cutting machine, Newton 597*

Macnab, E. S. M., Electric lighting of passenger cars 620*

Macgley, F. C., The shipper, the railway and the car man 293*

Magnet for removing metal from flesh, Westinghouse Elect. & Mfg. Co. 148*

Magnet steel, Qualities of 212†

Mahr Mfg. Co., Paint burner 1322*

Mahr Mfg. Co., Portable rivet forge 1283*

Mahr Mfg. Co., Safety hose clamp 145*

Maier, Charles, Saving coal 442†

Main reservoir, Ball joint connection for, Barco 487*

Main reservoir ball joint connection, Franklin Railway Supply Co. 254*

Main rod brasses, Boring and facing, by M. Flanagan 239*

Main rod brasses, Boring front end, by C. H. Andrus 196*

Main rod keys, Chuck for threading front end in a turret lathe 196*

Maintenance of equipment, Economical 107‡

Maintenance of locomotives, Some factors in, by E. Becker 140*

Malleable iron exhibit, American Malleable Castings Association 1319*

Malleable iron exhibit, American Malleable Castings Assn., correction 1353

Mare, M., Uniformity in car inspection 468

Master Blacksmiths' Association. (See International Railroad Master Blacksmiths' Association.)

Master Boiler Makers' Association convention 309

Master Car Builders' Association convention, Proceedings of 1327*, 1359*

Master Car Builders' Association, Election of officers 1395

Master Car Builders' Association, Forty-two years ago 348

Master Car Builders' Association, New experimental couplers 622*

Master Car Builders' Association, Results of letter ballot 567

Master Car Builders' Association, Revision of standards and recommended practice 1331*

Master Car Builders' billing machine, Burroughs 1354

Master Car Builders' rules of interchange 1323‡

Master Car Builders' rules of interchange, Revision of 1340

Master Car and Locomotive Painters' Association. (See Meetings.)

Master Car and Locomotive Painters' Association Convention, Proceedings of 539

Master Mechanics' Association, Associate members, make better use of 1207‡

Master Mechanics' Association. (See American Railway Master Mechanics' Association.)

Massachusetts Saw Works, High speed Hack Saw Machine 544*

Material, Accounting for second hand, Storekeepers' convention 285

Material and labor, Prices for, M. C. B. convention 1343

Material, Reclamation of 1208‡

Material, Reclamation of, Storekeepers' convention 317

Material, Reclaiming, at local shops, by E. A. Murray 631*

Mathews, J. A., et al, Factors in hardening tool steel 243*

Maxfield, H. H., Smokeless locomotive operation 561

Mechanical associations, To committees of Mechanical department, A field for the special investigator 604‡

Mechanical department and operating results 1208‡

Mechanical department, Relation to stores department 555‡

Mechanical department salaries, F. J. Miller 4†

Meetings

Air Brake Association 150, 203

American Electric Railway Association 549

American Railroad Master Tinner's, Coppersmiths' and Pipefitters' Assn. 323

American Railway Tool Foremen's Association 262, 379

American Society for Testing Materials 150, 323

American Society of Mechanical Engineers 51, 100, 323, 599, 647

Canadian Railway Club 323

Central Railroad Club 599

Chief Interchange Car Inspectors' and Car Foremen's Association 203, 434, 491

Chilled Car Wheel Manufacturers 599

The Engineering Foundation 100

Engineers' Society of Western Pennsylvania 549

Foundry and Machine Exhibition 492

International Association for the prevention of smoke 491

International Engineering Congress 50, 262

International Railroad Master Blacksmiths' Association 434

International Railway General Foremen's Association 50, 379

June Mechanical Convention 262, 599, 647

Master Car and Locomotive Painters' Association 204, 379, 434

Meeting at Franklin Institute 262

National Association of Corporation Schools 323

Traveling Engineers' Association 262, 492

Western Railroad Club 160, 323

Meetings, Joint M. M. and M. C. B., M. M. convention 1291

Men, The best methods of dealing with, by H. E. Gamble 61

Men, Cost of hiring and discharging 1268‡

Men, How do you select your, by R. V. Wright 387

Men, Methods of dealing with 55‡

Men, Scientific selection of 1384‡

Men, Selection of 1183‡

Men, Shop or railroad 211‡

Men, Steam railway and electrical operation 1307‡

Mertshheimer, F., Variable exhaust nozzle 1310*

Metal band saw, Williamson 488*

Metals, Protecting against heat 238†

Metallic packing equipment, Keeping up standards on 270†

Meter for recording flow over weirs, Harrison Safety Boiler Works 433*

Michigan Central, Shop kinks, Blacksmiths' convention 480*

Michigan Central, Special beading tool and boiler patch bolt 137*

Michigan Central, Y-fitting for washing out boilers 530*

Middleton, W. B., Guard for vise tail piece 247*

Middleton, W. B., Relief valve for superheater locomotives 416*

Mileage account, Locomotive 440‡

Mileage, Increased freight car 1323‡

Miller, F. J., Mechanical department salaries 4†

Miller, R. N., Defects of modern box cars and their remedies 171

Miller, R. N., Modern apprenticeship 532

Miller, Robert N., Shop efficiency 137

Milling machine, Heavy duty universal, Rockford Milling Machine Co. 146*

Milling machine (see machine tools)

Minneapolis, St. Paul & Sault Ste. Marie, Automatic drifting valve 593*

Minneapolis, St. Paul & Sault Ste. Marie, Manufacturing brooms 407*

Minneapolis, St. Paul & Sault Ste. Marie, Shop notes from 133*

Missouri, Kansas & Texas Ry., Machine tool lubricant pump 580*

Mitchell, A., Safety brake shoe 320*

Modern Tool Co., Collapsible tap 544*

Modern Tool Co., Self-contained grinding machine 91*

Moisture, Effect of, in the air brake system 623

Moisture in yard testing plants, Air brake convention 295

Morgan's Louisiana & Texas Ry., Reclaiming bolts with battered threads 39*

Morgan's Louisiana & Texas Ry., Using old boiler tubes as pipe 192*

Morrison, D. P., Barometric condenser as an open water heater 634*

Motive power department, Matters worthy of attention 1268‡

Motor drive for Bradley helve hammer, by W. E. Johnson 184*

Motors, Standardization of crane 585

Mott Sand Blast Mfg. Co., Plant for sand blasting steel cars 427*

Mounce, R. S., Southern locomotive valve gear 59*

Mummert-Dixon Company, Automatic facing tool 48*

Murray, E. A., Draft gear problem 498†

Murray, E. A., Melted boiler tubes 4†

Murray, E. A., Oiling air pump air cylinders 408*

Murray, E. A., Quadruple tool for planing shoes and wedges 584*

Murray, E. A., Reclaiming material at local shops 631*

N

Nagle, John H., Air pump rack 90*

Name, Our change in 605‡

Nathan Mfg. Co., Automatic drifting valve 372*

Nathan Mfg. Co., Force feed cylinder lubricator 489*

National Association of Corporation Schools (see Meetings.)

National Brake Co., Hand brake for freight cars 258*

National Hose Coupling Co., Hose coupling 432*

National Machinery Co., Automatic nut tapper 143*

National Machinery Co., Continuous motion hammer bolt heading machine 373*

National Railway Devices Co., Simple coupler release rigging 431*

Neff, J. P., Combustion in locomotive fireboxes, A. S. M. E. 10

Nehls Alloy Company, Carl, Metallic salts pyrometers 46*

Newton Machine Tool Works, Inc., Vertical slabbing machine 319*

Newton Machine Tool Works, Inc., Worm wheel cutting machine 597*

New York Central, Electric welding kinks 477*

New York Central, Portable oxy-acetylene welding and cutting outfit 592*

New York Central smoke washing plant, by M. D. Franey 511*

Niederlander, D. R., Lever hand brake 428*

Niles-Bement-Pond Co., Boring and turning mill 543*

Niles-Bement-Pond Co., Center drive car wheel lathe 321*

Niles-Bement-Pond Co., Cotter and key-seat drill 486*

Niles-Bement-Pond Co., Driving wheel lathe 371*

Niles-Bement-Pond Co., Pneumatic plate flanging clamp 145*

Nolan, J. P., Reclaiming bolts with battered threads 39*

Nolan, J. P., Using old boiler tubes as pipe 192*

Nordberg Mfg. Co., High compression oil engine 487*

Norfolk & Western Humidity controlled dry kiln, by W. H. Lewis 462*

Norfolk & Western, machine for driving boxes 138*

Northern Engineering Works, Electric crane trolley 97*

Northern Pacific steel passenger cars 517*

Nut lock, Air pump gland, N. T. Cline 322*

Nut lock, Positive, Schum Bros 320*

Nut tapping machine (see machine tools).

Nuway Packing Guard Co., Journal box packing guard 200*

O

Officers, Car department, and economy 330‡

Officers, Sweeping changes in 267‡

Officers, Training material for, by F. H. Thomas 370

Officers, Treatment of subordinate 1287‡

Ohio Injector Co., Squirt hose ejector 256*

Oil burner, Vacuum, Gustin-Bacon 260*

Oil burning locomotives, Smoke prevention with, T. E. A. convention 509

Oil engine, High compression, Nordberg 487*

Oil filter, Power plant, Richardson-Phenix 253*

Oil, Fuel, for locomotive use, Fuel convention 280*

Oil quenching baths, Determining the temperature of 451†

Oiler, Automatic force-feed flange, Detroit 1283*

Oils, Tests of lubricating 225

Oplinger, H. E., Removable wedge bolt 591*

Organization, Engine house, by W. P. Huntley 135*

Organization, Railway repair shop, by Henry Gardner 536*

Organization, Relation of engine house to engine failures, Harvey De Witt Wolcomb 533*

Organization, Toning up an, competition 554‡

Organization, Treatment of subordinates 1287‡

Orr, A. M., Prize article, Car inspectors' competition 575

Output, Quality of shop 441‡

Oxy-acetylene equipment, Imperial Brass Co. 107*

Oxy-acetylene joints, Strength of 645†

Oxy-acetylene process for boiler work, Boiler Makers' convention 300

Oxy-acetylene torch for closing valve links 538*

Oxy-acetylene welding copper and copper alloys, by J. F. Springer 367

Oxy-acetylene welding and cutting outfit, Portable, N. Y. C. 592*

Oxy-acetylene welding and cutting torch, Imperial 320*

Oxy-acetylene welding, General Foremen's convention 425

Page numbers under 1,000 refer to *Railway Age Gazette, Mechanical Edition*; those over 1,000 refer to the *Daily Railway Age Gazette*. *Illustrated article; ‡ editorial; † short non-illustrated article or note; ‡ communication.

Oxy-acetylene welding, Possible substitute for acetylene in 529
Oxy-acetylene welding, Restrictions on... 1207†

P

Packing guard, Journal box, Nuway Packing Guard Co. 200*
Packing iron for journal boxes... 137*
Packing, Metallic material, Lubricating Metal Co. 1286†
Packing rings, Piston valve, W. F. Lauer... 583*
Paint burner, Mahr 1322*
Paint color, Flat vs. enamel, Painters' convention 540
Paint, Maintenance of enamel color vs. varnish finish, Painters' convention 541
Paint materials, Test committee report, Painters' convention 539
Paint, Protection of iron and steel with, J. W. Gibbons 580*
Paint, Protection of steel with, Painters' convention 542
Paint shop, Piece work for a, by H. Hefelfinger 526
Paint shop, Relation of the, to the repair yards, by Wm. Buchanan 28
Paint sprayer, Vacuum, Gustin-Bacon 98*
Paint stock, quality vs. price in buying, Painters' convention 540
Paint, Temperature indicating 108†
Painters' Association (see Master Car and Locomotive Painters' Association).
Paints, Prepared, for metal surfaces, by Henry H. Gardner 513
Park, L. L., Does modern apprenticeship pay 248
Parsons Metal Products Co., Journal jack Patent, What is the value of a, by Paul Synnestvedt, M. C. B. convention... 1385
Patterns, Painting 4†
Patterns, Substitute for wooden 308†
Pearce, E. S., Locomotive headlight requirements 451*
Pennsylvania Railroad, Boring front end main rod brasses 196*
Pennsylvania Railroad, Exhaust nozzle with internal projections 198*
Pennsylvania Railroad, Extensible vestibule trap door 430*
Pennsylvania Railroad, Forging dies, Blacksmiths' convention 476*
Pennsylvania Railroad, Four wheel truck for passenger cars... 569*
Pennsylvania Railroad shop kinks, Blacksmiths' convention 480*
Pennsylvania Railroad test department 329§, 332*
Perry, H. M., Car derailments, causes and a remedy 619*

Personals—General

Ayers, A. R. 150
Bast, P. E. 549
Bartlett, Henry 324
Billingham, R. A. 647
Bisbee, Sheridan 264
Boardman, F. W. 549
Bosworth, W. M. 379
Brassill, J. K. 101
Brooks, C. E. 324, 500
Brown, R. M. 150
Brown, T. U. 51
Cartwright, H. W. 647
Chidley, Joseph 150
DeVilbiss, E. B. 379
Duguid, J. 101
Eager, A. H. 600
Elmes, C. C. 600*
Elsner, William H. 435
Gallagher, F. S. 150
Geiser, W. B. 150
Gillespie, W. 51
Good, G. W. 379
Graburn, A. L. 600
Hamilton, M. E. 647
Harris, E. J. 549
Haymond, F. O. 549
Hazard, W. L. 600
Hessenbruch, T. E. 647
Hooper, N. C. 435
Hungerford, S. J. 324
MacBain, D. R. 101
MacRae, J. A. 492*
McKinnon, A. 435
McNiece, W. B. 435
Macbeth, H. A. 264, 324
Main, D. T. 264
Milner, B. B. 379
Mirtz, P. P. 150
Mitchell, J. A. 600
Moffatt, J. F. 435
Needham, E. F. 150
O'Brien, J. E. 549
Oviatt, H. C. 51*
Owens, W. H. 549
Reese, O. P. 379
Roblin, L. G. 435
Roquemore, P. 150
Schmalzreid, W. M. 549
Seabrook, C. H. 51
Seiders, I. A. 600
Sheafe, J. S. 435
Smith, H. E. 150
Smith, William C. 549
Sproule, Gordon 600
Stiffey, S. S. 51
Summerskill, T. A. 51
Taylor, F. W. 101

Personals—General—(Continued)

Thompson, W. O. 550*
Thomson, S. G. 600
Vaughan, H. H. 264
Warner, W. W. 549
White, H. J. 549
Whitley, G. 150
Winterrowd, W. H. 324
Woodhouse, W. E. 264

Personals—Master Mechanics and Road Foremen of Engines

Albright, T. A. 550
Armstrong, S. T. 550
Baldwin, T. C. 264, 324
Barker, N. M. 52, 151*
Barry, F. J. 101
Barton, D. E. 101
Baum, J. W. 647
Bell, Norman 101
Bissett, J. R. 52
Boldridge, R. M. 550
Bowen, John R. 550
Bryant, E. J. 150
Carey, F. J. 379
Carlson, F. C. 550
Caskey, A. F. 150
Cassady, J. A. 52
Clark, J. J. 52
Clough, D. I. 550
Connors, C. 379
Cramer, H. 52
Dales, A. E. 150
Dolan, J. P. 101
English, H. A. 647
Evans, G. I. 379
Findlay, J. W. 379
Fisher, L. G. 150
Fitzsimons, J. E. 52
Flavin, J. T. 151
Fletcher, W. H. 550
Goodrich, G. P. 204
Gould, J. E. 600
Graham, G. S. 151
Griest, E. E. 102*
Hallman, A. 52
Hamlet, A. E. 52
Hardin, L. A. 379
Heinzer, J. P. 550
Henry, G. W. 52
Higgins, D. W. 52
Howser, H. F. 101
Hudson, T. C. 550
Huston, F. T. 101
Johnson, J. W. 204
Keller, W. H. 151, 380*
Keyser, E. E. 647
Kincaid, R. M. 600
Kyle, C. 151
Langhurst, E. J. 52
Lillie, Grant W. 550
Linthicum, P. 550
McAlpine, J. H. 550
McCann, E. H. 52
McConachie, W. G. 379
McElrath, William 52
McMillan, A. E. 151, 204
McPartland, M. B. 379
McQuade, R. J. 204
Mahan, A. H. 379
Malthaner, W. 102
Mills, J. H. 325
Moffatt, J. F. 379
Moore, W. C. 379, 600
Nevins, B. E. 647
Payne, W. W. 52
Pickrell, W. J. 325
Powell, A. H. 264
Quantic, C. J. 647
Reid, J. J. 151
Ried, H. G. 380
Ronaldson, F. 647
Schriver, J. L. 102
Scott, M. J. 380
Scott, W. L. 205
Sealy, W. C. 325
Selfridge, H. 151
Simpson, H. R. 380
Sisco, G. E. 380
Sturrock, A. 151, 380
Van Aiken, E. B. 151
Watt, A. 380
Wilmore, F. W. 380
Windle, T. 325
Young, A. C. 151, 204*

Personals—Car Department

Alquist, P. 380, 435
Andrew, H. W. 600
Berg, A. 151
Blodd, O. 151
Brice, A. D. 52
Chandler, R. L. 550*
Copony, A. 205
Decker, G. E. 550
Dempster, W. C. 52
Eley, E. 600
Fickel, John A. 102
Fitz, R. A. 151
Forrest, W. 380
Grove, W. E. 648
Hacking, E. 600
Hawkins, John M. 102
Hilhorn, A. M. 551
Hodgson, J. 264
Hodgson, J. L. 600
Hooker, N. E. 52

Personals—Car Department—(Continued)

Jander, A. P. 551
Johnston, J. E. 600
Kipp, A. 102
Lamb, V. J. 205
Lilly, R. 102
Long, W. H. 380
McClellan, C. H. 102
McCowan, A. 600
McNiece, W. B. 151
Marshall, T. W. 205
Messeroll, D. C. 102
Miller, W. F. 380
Mills, W. 102
Mounce, R. S. 325
Munro, C. A. 600
Murdock, C. A. 102
Pieric, W. H. 648
Reid, F. 102
Spence, T. 152
Stone, C. E. 52
Thiel, E. J. 600
Thompson, George 152
Turner, G. H. 102
Van Buren, C. W. 264
Walker, William 380
Weldon, R. D. C. 102
White, H. J. 647*
White, L. C. 325
Wilhite, J. A. 52
Zercher, F. B. 325

Personals—Shop and Engine House

Archer, W. H. 380
Atwell, Leon 52
Band, R. W. 380
Beardshaw, A. 205
Becker, H. G. 325
Bloom, E. 152
Brandt, William 325
Burel, W. C. 205
Burton, J. A. 52
Carey, J. J. 551
Cleary, L. A. 551
Darby, H. 600
Feetham, G. 435
Gordon, S. 102
Hacking, E. 102
Hannah, A. T. 601
Hay, D. W. 380
Hening, C. R. 52
Hillman, G. A. 52
Hope, W. 325
Howell, F. P. 325
Jones, L. B. 601
Kendall, A. H. 435
Kerwin, J. M. 264
Kinsell, W. L. 648
Laycock, G. H. 152, 551
Lowe, T. S. 325
Lundburg, C. 152
McCarra, M. F. 264
McRae, John 152, 492
McTavish, A. 325, 601
Miller, J. A. 380
Miller, R. A. 205
Mitchell, J. A. 152, 325
Moran, W. F. 52
Morey, E. H. 152
Moses, F. K. 52
Mueller, S. E. 52
Newman, C. M. 152
Nolan, William H. 325
Ord, L. C. 435
Osborne, H. 264
Palos, T. W. 325
Patterson, W. R. 205
Pontius, J. H. 551
Raubert, F. A. 601
Rogers, J. D. 551
Ross, D. 205
Schneider, J. S. 551
Shaler, H. 551
Smith, Bert 52
Spicer, H. C. 325
Stewart, C. E. 205
Stone, J. H. 52
Walton, J. A. 325
Warren, F. W. 102
Wells, W. 435
White, C. 435
Wilder, C. D. 205
Wolfe, F. E. 52
Wood, W. B. 551
Woods, John E. 205
Young, R. R. 205

Personals—Purchasing and Storekeeping

Bowen, H. W. 648
Burgess, C. L. 102
Burns, E. J. 52
Calhoun, F. B. 648
Coles, J. M. 102
Cooke, T. W. 102
Desaloux, J. B. A. 102
Dugan, F. P. 601
Dunbar, Frank 205
Francis, W. D. 648
French, C. D. 380
Gehan, G. W. 264
Goodwin, E. G. 102
Harpke, G. C. 551
Harvey, J. 648
Hinkey, W. M. 648
Hunter, A. P. 102
Hutchinson, A. E. 380
Ingersoll, G. R. 102
Jacobs, R. A. 492

Page numbers under 1,000 refer to Railway Age Gazette, Mechanical Edition; those over 1,000 refer to the Daily Railway Age Gazette. *Illustrated article; †editorial; ‡short non-illustrated article or note; ¶communication.

Personals—Purchasing and Storekeeping—(Continued)

Jobin, G. H. 264
 Keller, Joseph 102
 Lavender, C. 648
 Lepard, C. E. 601
 Lunsford, R. A. 435
 Moorcroft, S. K. 380
 Morehead, W. S. 601
 Murphy, J. P. 103
 Murphy, P. J. 103
 O'Brien, John 205
 Owen, Walter R. 325
 Peabody, W. L. 551
 Powell, H. M. 492
 Price, E. J. 492
 Reed, F. D. 264*
 Robinson, G. H. 380
 Roth, E. J. 264
 Rothcary, C. H. 648
 Sewell, H. A. 103
 Stewart, W. D. 601
 Stokes, W. D. 601
 Sweing, A. J. 648
 Thomson, L. C. 52
 Toye, Eldred C. 52
 Urtel, E. J. 264
 Woods, J. L. 648*
 Yeomans, G. J. 648

Personals—Commission Appointments

Alexander, Walter 152*
 Herndon, H. A. 435
 Moler, A. L. 325

Personals—Obituary

Addis, J. W. 205
 Allen, W. F. 648*
 Chapman, T. L. 103
 Charlton, Matthew 52
 Cohen, Mendes 551
 De Voy, J. F. 649
 Fox, Patrick 325
 Hayward, Charles 380
 Henderson, Edmund P. 103
 Laurie, J. B. 103*
 McCann, Charles 205
 McGee, James 264
 McIntosh, William 205*
 Markey, James 325
 Meier, Col. E. D. 52
 Mirtz, P. P. 325
 Moran, J. J. 551
 Salmon, R. B. 649
 Sherwood, M. E. 380
 Thompson, Charles A. 103
 Waldron, N. A. 380
 Philadelphia & Reading, 4-4 type passenger locomotive 1193*
 Piece work accounts, Handling, Painters' convention 541
 Piece work, Blacksmiths' convention 473
 Piece work and bonus systems in the boiler shop, by N. H. Ahstuoili 240*
 Piece work and its advantages, by E. J. Thill 122
 Piece work for a paint shop, by H. Hef-selinger 526
 Piece work system, Freight car repairs under a, by J. J. Tolin 347
 Pipe bender, Hydraulic Press Manufacturing Co. 142*
 Pipe connections, Flexible, between engine and tender, Barco 1285*
 Pipe joint, Universal, Christy Universal Pipe Joint Company 98*
 Pipe threading and cutting machine (see Machine Tools).
 Pipe threading tools with internal guide, Greenfield 261*
 Piston rod gland and oiler, by James Stevenson 183*
 Piston rod packing, Sullivan 596*
 Piston rods, Tests of special steel 530†
 Piston valve, (see Valve).
 Pistons, Forged and rolled steel, by W. W. Scott, Jr. 343*
 Pitard, J. H., How can I help the apprentice 642
 Pittsburgh, Shawmut & Northern, Steel underframe caboose 231*
 Pittsburgh & Lake Erie, Barometric condenser as an open water heater 634*
 Pittsburgh & Lake Erie, Well car, 200,000-lb. capacity 397*
 Plant for building cars, A Spanish 140†
 Pneumatic hammer, C. B. & Q. 586*
 Pneumatic hammer for reclaiming track spikes 632*
 Pneumatic hammer, Tools for facing connections, Tool Foremen's convention 414*
 Pneumatic tools, Maintenance of, Tool Foremen's convention 413*
 Pomeroy, L. R., Diagram for determining maximum tractive effort 453*
 Pomeroy, L. R., An electric process for safe-ending tubes 469*
 Pomeroy, L. R., Length of radius bar 290*
 Portuguese State Railways express locomotive 116*
 Power, High, per unit of weight 106‡
 Powerhouse, Turning commutators in, by H. L. Loucks 470*
 Practice, Recommended, Air Brake convention 298*
 Practice, Recommended, Storekeepers' convention 286
 Pratt, E. W., Smoke prevention 274*

Press for closing crown brasses, C., St. P., M. & O. 528*
 Press for hard grease, Franklin Railway Supply Co. 322*
 Preston, W. E., Effect of valve gear on locomotive operation, T. E. A. convention 505
 Prices for labor and material, M. C. B. convention 1343
 Prices, Settlement, for reinforced wooden cars, M. C. B. convention 1344
 Price, Towson, Calibration charts for Vanderbilt tenders 563*
 Prosperity and the railways 605‡
 Pump, condenser vacuum, Ingersoll-Rand 594*
 Pump for machine tool lubricant, M. K. & T. 589*
 Pump, small single-acting hydraulic, Hydraulic Press Mfg. Co. 197*
 Pump, Triplex hydraulic, Watson-Stillman 146*
 Punching machine (see machine tools).
 Pyle-National Electric Headlight Co., Incandescent headlight equipment 1199*
 Pyle-National Electric Headlight Co., Young valve gear, reverse gear and valve 1284*
 Pyrometers, Metallic salts, Carl Nehls Alloy Company 46*

R

Radius bar, Length of, for two-wheel trucks, by L. R. Pomeroy 290*
 Railroad, The mechanical side of, by Wm. Schlafe 283
 Railway Electrical Engineer, The 495‡
 Railway Fuel Association (see International Railway Fuel Association).
 Railway General Foremen's Association (see International Railway General Foremen's Association).
 Railway Storekeepers' Association convention 285
 Railway Supply Manufacturers' Association 1187*
 Railway Supply Manufacturers' Assn., Election of executive members 1287‡
 Railway Tool Foremen's Association (see American Railway Tool Foremen's Association).
 Railways, Prosperity and the 605‡
 Rain water, Chemical properties of 4†
 Ralston Steel Car Co., Flush box car door 1354*
 Ready Tool Co., Safety belt stick 597*
 Reamer, Heavy duty electric, Cincinnati Electric Tool Co. 199*
 Reamers, Standard, Tool Foremen's convention 416
 Recorder for measuring flow over weirs, Harrison Safety Boiler Works 433*
 Records worthy of attention 1268‡
 Reciprocating and revolving parts 106‡
 Reciprocating and revolving parts, by H. A. F. Campbell 109*, 163*, 215, 390*, 443*
 Reciprocating parts, Light 1288‡
 Relief valve for superheater locomotives, by W. B. Middleton 416*
 Repair facilities, Provide good car 1383‡
 Repair shops, Joint car 1383‡
 Repair work, Engine house, by M. Vallen 85
 Repairs, Billing on foreign cars 106‡
 Repairs, Compensation for car, M. C. B. convention 1343
 Repairs, Economics in freight car 129
 Repairs, Freight car, under a piece work system, by J. J. Tolin 347
 Repairs, Improper charges for car 1324‡
 Repairs, Locomotive running, by Ernest Cordeal 37
 Repairs, Running, by Railroader 41
 Reverse gear, Can. Pac., 4-8-2 type 560*
 Reverse gear, Young 1284*
 Richardson-Phenix Co., Oil filter 253*
 Riegel, S. S., Water tube firebox on the Lackawanna 222*
 Rigid Tool Holder Co., Boring tool holders 595*
 Riley, J. W., Safety wrecker yoke 547*
 Rings, Device for forming, under the steam hammer, Blacksmiths' convention 481*
 Rivet forge and blow torch, Portable 191*
 Rivet forge, Mahr Mfg. Co. 1283*
 Rivet set, Combination, by H. L. Loucks 251*
 Riveting machine, Hanna 547*
 Riveting in steel car construction 2‡
 Riveting in steel car construction, by H. A. Hatfield 33*, 87*
 Road foreman, Qualifications of a 1287‡
 Robinson, W. L., Powdered coal 271
 Rock Island Lines, Economic study of mikado vs. consolidation 615
 Rock Island Lines, Simple furnace for melting brass 36*
 Rockford Milling Machine Co., Heavy duty universal milling machine 146*
 Rod brasses, Boring front end main 196*
 Rod brasses, Index head for holding 140*
 Rods, Stresses in side, W. F. Kiesel, Jr. 212‡
 Rogers, Robert W., Exhaust injectors 514*
 Roller bearings, journal, Anti-Friction Roller Bearing Co. 141*
 Roof construction for passenger cars, Johnson 485*
 Roofs, Testing car, Santa Fe 399*
 Roundhouse (see Engine house).
 Rubber, Instruments for measuring hardness and elasticity of, Shore 374*
 Rule, Uniform, for load on stay bolts, Boiler Makers' convention 313
 Rules, Book of standard, Storekeepers' convention 290
 Rules, Loading, M. C. B. convention 1366*

Rules of interchange, Discussion of Car Inspectors' convention 524
 Rules of interchange, M. C. B. 1323‡
 Rules of interchange, Revision of, M. C. B. convention 1340
 Ryan, T. T., Prize article, boiler inspectors competition 635*
 Ryerson & Son, Jos. T., Elliptic spring forming machine 593*
 Ryerson & Son, Jos. T., Punch and shear 198*

S

Safety Car Heating & Lighting Co., Ceiling fan 1352*
 Safety Car Heating & Lighting Co., Under-frame suspension of car lighting generators 257*
 Safety first in railway shops 383‡
 Safety first, Tool Foremen's convention 412
 Safety valve, Crane & Co. 255*
 Salaries, Mechanical department 4‡
 Samson, C. H., Accounting for second hand material 285
 Sand blast helmet, J. M. Betton 146*
 Sand blast house, Jersey Central freight car repair shops 65*
 Sand blasting steel cars, American Engineering Co. 376*
 Sand blasting steel cars, Plant for, Mott 427*
 Sand dryer, Oil burning, by F. G. Lister 407*
 Sander, Locomotive, White 1353*
 Sargent Co., Safety water glass cock 1303
 Saw guard, Adjustable, Hobart W. Curtis 95*
 Schaff, W. F., Letter on car inspection, Car Inspectors' convention 523
 Schlafe, Wm., The mechanical side of railroading 283
 Schmidt, Edward C., Japanese Railways dynamometer car 66*
 Schoenen, Herman, The special apprentice 270‡
 Schultz, F. C., Joint car repair shops at large terminals 30
 Schum Bros., Positive nut lock 320*
 Scott, W. W., Jr., Forged and rolled pistons 343*
 Scrap and scrap classification, Storekeepers' convention 285
 Scrap lumber from box cars 1323‡
 Scrap material, Reclaiming 155‡
 Scrap, Reclaiming, Blacksmiths' convention 473
 Scrap reclamation plant, Great Northern 305*
 Scrap, Reclamation of, Storekeepers' convention 317
 Second hand material, Accounting for, Storekeepers' convention 285
 Selection of men, by R. V. Wright 387
 Selection of men, Scientific 1384‡
 Sequence, Analysis of dependent, as a guide to fuel economies, Fuel convention 273
 Shamberger, J. P., A study of spring rigging design 15*
 Shearing machine (see Machine tools).
 Shinn & Co., M. E., Vertical band saw for metal cutting 142*
 Shipper, The, the railway and the car man 293*
 Shoe and wedge chuck for milling machine table, by R. E. Brown 591*
 Shoes and wedges, Turret head for planing, by B. O. Yearwood 187*
 Shoes and wedges, Quadruple tool for planing, by E. A. Murray 584*
 Shoemaker, H., Crane arrangement for locomotive shops 372*
 Shop craft committee meetings 156‡
 Shop efficiency, General Foremen's convention 421
 Shop efficiency, some methods of securing, by Harvey De Witt Wolcomb 639
Shop Kinks
 Adjustable drilling stand, Canadian Government Railways 42*
 Air pump rack, B. R. & P. 90*
 Air pump, Reinforced asbestos gaskets for 469*
 Air pump, Repairing 9/16-in. cylinder heads, A. C. L. 530*
 Air pump repairs, Special chuck for, C. of Ga. 183*
 Air pump reversing rods, Repairing worn, by J. A. Jesson 242*
 Air pumps, Device for placing, C. & N. W. 581*
 Air pumps, Method of cleaning, C. & N. W. 82*
 Anvil attachment for oblique bending, Pennsylvania 480*
 Arc-welding a locomotive cylinder, New York Central 477*
 Babbitt furnace for driving box hub liners, C., St. P., M. & O. 527*
 Beading tool, Michigan Central 137*
 Bell yoke bearing reamers, Chicago & North Western 36*
 Bench arrangement for cleaning triple valves, C., B. & O. 568*
 Blacksmiths' convention 480*
 Boiler tubes, Using old as pipe, Morgan's L. & T. Ry. 192*
 Boring and facing back end main rod brasses and driving boxes, C. & O. 239*
 Brake beam safety strap, Former for, Mich. Cent. 480*
 Brake shaft supports, Formers for, B. & L. E. 480*
 Car stakes, Form for bending steel, B. & L. E. 480*

Page numbers under 1,000 refer to *Railway Age Gazette, Mechanical Edition*; those over 1,000 refer to the *Daily Railway Age Gazette*. *Illustrated article; ‡ editorial; † short non-illustrated article or note; ‡ communication.

Shop Kinks—(Continued)

Chuck for finishing air pump packing rings, by F. R. Stewart..... 589*

Chuck for finishing boiler check bodies, C. of Ga..... 133*

Chucks for threading fire door latches and front end main rod keys in a turret lathe, C. of Ga..... 196*

Cleaning carpets by compressed air, C. & W. I..... 567*

Commutators, Turning in the powerhouse, Erie..... 470*

Coupler yokes, Tools for removing, forming and riveting, C. B. & Q..... 592*

Crane, Pillar for machine tools, Canadian Northern..... 360*

Crosshead shoes, Jig for babbitting, C. & St. P..... 410*

Crown brasses, Jig for setting up in the sharper, by Lewis Lebovitz..... 370*

Cylinder cocks, Finishing, A. C. L..... 195*

Cylinder heads, Attachment for grinding, Soo Line..... 133*

Device for determining height of crown sheets, Ill. Cent..... 410*

Device for straightening bent axles, C. & O..... 631*

Dies for forming large castle nuts, C. & N. W..... 412*

Drill motor extensions, by V. T. Kropidowski..... 579

Drill post, Angle, Ill. Cent..... 409*

Drilling device for firebox work, Wash-bash..... 412*

Driving boxes, Machine for boring, N. & W..... 138*

Dry pipe joints, Jig for grinding, Wash-bash..... 411*

Eccentric cranks, Tool for locating, Ill. Cent..... 410*

Eccentrics, Jig for planing, Erie..... 188*

Engine bolts, Turning, Central of Georgia..... 193*

Feed valve testing clamp, Soo Line..... 134*

Finishing car and engine truck brasses by grinding, A. C. L..... 193*

Finishing tank valve castings, C. of Ga. Cent..... 82*

Flue cutter, apparatus for driving, Ill. Cent..... 410*

Flue cutter, by Lewis Lebovitz..... 542*

Flue cutter, Superheater, Ill. Cent..... 409*

Forging machine dies, by J. Lee..... 37*

Frames, Method of arc welding..... 477*

Furnace for melting brass, Rock Island Lines..... 36*

Gas brazing furnace, C. & N. W..... 591*

Grinding distributing valves, C. N. O. & T. P..... 39*

Grinding wheel protection, Can. Pac..... 249*

Guard for vise tail piece, A. C. L..... 247*

Guide bars, Jigs for grinding, A. C. L..... 242*

Hoist for loading scrap wheel, C. & O..... 631*

Horizontal drilling attachment for a radial drill, by V. T. Kropidowski..... 40*

Index head for holding rod brasses..... 140*

Jig for drilling dry pipe collars, by F. W. Bentley, Jr..... 81*

Journal box packing iron, C. & N. W..... 137*

Lifting hook for placing work in lathe, Soo Line..... 133*

Link trunnion, Dies for forming, Pennsylvania..... 476*

Lubricator choke plugs, Reclaiming worn, by F. W. Bentley, Jr..... 252*

Main rod brasses, Boring front end, Pennsylvania..... 196*

Motor drive for Bradley helve hammer, Western Pac..... 184*

Oil burning blacksmith forge, S. P. & S. Oxy-acetylene welding and cutting outfit, N. Y. C..... 592*

Pilot coupler gage, A. C. L..... 216*

Pneumatic flue cutter, C. & N. W..... 86*

Pneumatic hammer, C. B. & Q..... 586*

Pneumatic hammer for reclaiming track spikes..... 632*

Portable attachment for operating hydraulic press, Soo Line..... 134*

Post cluster for extension cord plugs..... 192*

Press for closing crown brasses, C. St. P., M. & O..... 528*

Pump for machine tool lubricant, M., K. & T..... 589*

Reboring air pump cylinders, by J. A. Jesson..... 138*

Reclaiming bolts with battered threads, M. L. & T..... 39*

Removing gaskets from bullseye lubricators, Louisville & Nashville..... 39*

Removing indentations in superheater smoke tubes, C. & O..... 40*

Repairing worn tail braces, A. C. L..... 90*

Rings, Device for forming under steam hammer, Pennsylvania..... 481*

Rivet forge and blow torch, Portable, C. & N. W..... 191*

Rivet set, Combination, Erie..... 251*

Rotary four-way valve, by E. H. Wolf..... 542*

Sand Dryer, Oil Burning, Spokane, Portland & Seattle..... 407*

Shoe and wedge chuck for milling machine table, A. C. L..... 591*

Shoes and wedges, Quadruple tool for planing, C. & O..... 584*

Sill steps, Device for forming, Great Northern..... 641*

Sill steps, Device for forming, Mich. Cent..... 480*

Shop Kinks—(Continued)

Spring banding machine, L. I..... 480*

Spring hangers, Dies for forming driving, Pennsylvania..... 476*

Steam gage and safety valve clips for date tags, C. of Ga..... 131*

Steam gages, method of securing, C. & N. W..... 364*

Stenciling gage for freight cars, A. C. L..... 468*

Stenciling outfit, Freight car, Boston & Maine..... 458*

Testing air motors, Apparatus for, N. & W..... 414*

Throttle valve seat reamer, Wabash..... 411*

Tire flanging tool, Double, A. C. L..... 308*

Tire lifting hook, Soo Line..... 134*

Tools for facing air hammer connections, N. & W..... 414*

Tools tipped with high speed steel..... 590*

Turnbuckles, Dies for forming, Pennsylvania..... 476*

Turret head for planing guides, shoes and wedges, Virginian..... 187*

Valve chamber bushings, Gear train used in pulling in..... 359*

Valve motion links closed with oxy-acetylene torch, Lehigh Valley..... 538*

Valve packing rings and bull rings, Chuck for finishing..... 359*

Valve seat port miller, Wabash..... 411*

Y-biting for washing out boilers, Michigan Central..... 530*

Shop operation, Economy in..... 1*

Shop organization, by Henry Gardner..... 536*

Shop output, quality of..... 441*

Shops, Efficiency in railroad..... 603*

Shops, Keeping clean..... 105*

Shops, Jersey Central freight car repair..... 62*

Shops, Joint car repair..... 1383*

Shops, Safety first in railway..... 383*

Shore Instrument & Mfg. Co., Instruments for measuring hardness and elasticity of rubber..... 374*

Signal material, Handling, Storekeepers' convention..... 280

Signal, Operation of the pneumatic train, Air Brake convention..... 296*

Signal and train brake equipment, M. C. B. convention..... 1334*

Silberberg, Mortimer J. Time study watch..... 261*

Sill step, Device for forming, Blacksmiths' convention..... 480*

Sillcox, L. K., Considerations affecting type of center sills in steel passenger equipment..... 227*

Sitterly, W. H., Improper loading of box cars..... 233

Sill steps, Device for forming, by John Treacy..... 641*

Slabbing machine (see Machine tools).

Slack adjuster for brake equipment, Johns-Manville..... 1419*

Slack adjuster, Manual, for freight cars, Johns-Manville..... 644*

Slarrow, G. C., "The Doctor of Cars"..... 628

Smith, Joseph, Helping the apprentice by sympathy and co-operation..... 531

Smith Locomotive Adjustable Hub Plate Co., Adjustable hub plate..... 486*

Smith, P. F., Repairing driving boxes..... 527*

Smoke, Abatement of locomotive, in Cincinnati, by G. H. Funk..... 566

Smoke elimination, Educating engineers in..... 216

Smoke prevention, Fuel convention..... 274*

Smoke prevention, Locomotive..... 1207*

Smoke prevention, M. M. convention..... 1222

Smoke prevention with oil burning locomotives, T. E. A. convention..... 509

Smoke prevention without special apparatus, by H. H. Maxfield..... 561

Smoke washing plant, N. Y. C., by M. D. Franey..... 511*

Smokebox blower fitting, Barco..... 595*

Southern locomotive valve gear, Kinematic diagram of..... 59*

Southern Pacific six-volt electric headlight equipment, by A. H. Babcock..... 613*

Southern Railway, Steam tender locomotive..... 613*

Southern valve gear, Laying out the, by Harry Cornell..... 3861*

Specifications, Forging, M. M. convention..... 1296

Specifications and tests for materials, M. C. B. convention..... 1373*

Specifications and tests of materials..... 1355*

Spicer, H. C., Gage for pilot coupler..... 216*

Spicer, H. C., Repairing worn tail braces..... 90*

Spicer, E. T., Grinding wheel protection..... 249*

Spokane, Portland & Seattle, Oil-burning blacksmith forge..... 633*

Spokane, Portland & Seattle, Oil burning sand dryer..... 407*

Spring banding machine, Blacksmiths' convention..... 480*

Spring design, Plate..... 155*

Spring forming machine, Universal elliptic, Ryerson..... 593*

Spring making and repairing, Blacksmiths' convention..... 474

Spring rigging design, A study of, by J. P. Shamberger..... 15*

Springs, Characteristics of plate, by Geo. S. Chiles..... 161*, 219*, 340*, 392*

Springer, J. F., A possible substitute for acetylene in welding and cutting..... 529

Springer, J. E., Welding copper and copper alloys by acetylene methods..... 367

Springfield Manufacturing Co., Car wheel grinder..... 143*

Standard box car—a negative viewpoint, by R. W. Burnett..... 121

Standards and recommended practice, Revision of, M. M. convention..... 1217*

Standards, revision of, M. C. B..... 1331*

Stark Car Coupler Corp., Automatic coupler with movable guard arm..... 1382*

Stationery, Storekeepers' convention..... 288

Stay bolts, Driving, Boiler Makers' convention..... 315

Stay bolts, Uniform rule for load on, Boiler Makers' convention..... 313

Stays, Cross, in fireboxes, Boiler Makers' convention..... 314

Steam gage and safety valve clips for date tags, by C. L. Dickert..... 131*

Steam gages, Method of securing, by W. S. Whitford..... 364*

Steam, Storing, at the engine..... 588†

Steel, Alloy and heat-treated carbon, for reciprocating parts..... 215

Steel, Carbon and high speed, Blacksmiths' convention..... 472

Steel, Carbon-vanadium forging..... 1286

Steel, Cause of high speed, tool failures, by Geo. J. Brunelle..... 369

Steel, Heat treated and alloy, by C. D. Young, at A. S. M. E..... 13

Steel, Heat treatment of..... 210*

Steel, Heat treatment of, Blacksmiths' convention..... 480

Steel, High speed, tipped tools..... 590*

Steel, Protection of iron and..... 553*

Steel, Protection of iron and, by J. W. Gibbons..... 580*

Steel, Protection of, with paint, Painters' convention..... 542

Steel, soft for small tools, by Owen D. Kinsey..... 189*

Steins, Carleton K., Give apprentices responsibility..... 532

Stencil gage for freight cars, by W. F. James..... 468*

Stenciling outfit, Freight car, by H. F. Blossom..... 458*

Step-ladder for sleeping cars, Can. Nor..... 238*

Stevenson, James, Piston rod gland and oiler..... 183*

Stewart, F. R., Chuck for finishing air pump packing rings..... 589*

Stoker engines, Thin fires for..... 1267*

Stoker, The mechanical..... 1207*

Stoker, What the, has done for the locomotive, by E. A. Averill and C. F. Street, at A. S. M. E..... 11

Stokers and increased capacity..... 1207*

Stokers, Locomotive, M. M. convention..... 1214*

Stokers, Mechanical, Fuel convention..... 277

Store expenses, Accounting for..... 287

Stores department, Relation to mechanical department..... 555*

Storekeepers' Association (see Railway Storekeepers' Association).

Street, C. F., What the stoker has done for the locomotive, A. S. M. E..... 11

Strength, Reduction of, in corroded or pitted boiler shells, Boiler Makers' convention..... 315

Stresses in truck side frames, Experiments to determine the, by L. E. Endsley..... 127*

Subordinates, Treatment of, by L. E. Endsley..... 1297*

Superheat and compounding..... 1267*

Superheater, The, and fuel economy, M. M. convention..... 1276

Superheater locomotives, Compounding, M. M. convention..... 1220

Superheater smoke tubes, Removing indentations in, by H. M. Brown..... 40*

Superheaters, High water and..... 267*

Superheaters, Locomotive, by G. L. Bourne, at A. S. M. E..... 12*

Supervision, More, needed..... 209*

Supervision, Sufficient and competent..... 384*

Supply man, The, at conventions..... 384*

Supply man, Welcome the..... 329*

Synnestvedt, Paul, What is the value of a patent? M. C. B. Convention..... 1385

Supply Trade Notes

Acme Supply Co..... 493, 649

Adams & Westlake Co..... 381

Adams Bagnall Electric Company..... 326

Alderdice, George F..... 436

Allen & Son, A..... 436

Allen, S. G..... 265

Allen, W. C..... 206*

Allis-Chalmers Co..... 326

American Blue Print Paper Co..... 265

American Can Co..... 326

American Car & Foundry Co..... 602

American Locomotive Co..... 326, 436, 650

American Manganese Steel Company..... 326

American Spray Co..... 493

American Steel Export Co..... 436

American Vanadium Co..... 265, 493, 649

Anderson, Larz..... 326

Baker, M. G..... 265

Baldwin Locomotive Works, 53, 327, 436, 601

Ball, H. F..... 265

Ballman, E. C..... 326

Ballman-Witten Manufacturing Co..... 326

Barrett, G. G..... 152

Bartlett-Hayward Co..... 493

Bauer, W. F..... 53

Bayonne Steel Casting Company..... 326

Beckert, Louis F..... 436

Page numbers under 1,000 refer to *Railway Age Gazette*, Mechanical Edition; those over 1,000 refer to the *Daily Railway Age Gazette*. *Illustrated article; †editorial; ‡short non-illustrated article or note; † communication.

Supply Trade Notes—(Continued)

Belknap, R. E. 602
 Best, H. W. 326
 Best, Leigh 436
 Bethlehem Steel Co. 493
 Biggs, P. H. 326
 Biggs, P. H., Machinery Co. 326
 Bird-Archer Co. 153*
 Booth Co., L. M. 551
 Boss Nut Co. 206
 Boston Belting Co. 601
 Bouton, C. B. 551
 Brier Hill Steel Co. 436
 Brown, Edward C. 265
 Brown, R. S. 381
 Buck, H. M. 436
 Buda Co. 326
 Buffalo Brake Beam Co. 436
 Burnett, R. W. 649
 Burwell, L. T. 649
 Butler Co., Ltd., W. W. 152
 C & C Electric Co. 551
 Cambria Steel Co. 152, 381, 436
 Campbell, H. A. F. 436
 Canadian Car & Foundry Co. 152, 493
 Cantley, Thos. 493
 Carless, Thomas E. 436
 Carnes, W. B. 265
 Carpenter Steel Co. 206
 Cate, I. M. 650
 Caughey, E. B. 326
 Central Iron Works 326
 Chambers Valve Co. 382
 Chapman, W. C. 206
 Charbono, F. H. 381
 Chicago Malleable Castings Co. 152
 Chicago Pneumatic Tool Co. 265
 Chicago Railway Signal & Supply Co. 649
 Cincinnati Gear Cutting Co. 326
 Cincinnati Milling Machine Co. 326
 Cincinnati Shaper Co. 326
 Clark, Walter L. 327
 Coffin, Joel S., Jr. 265, 551
 Cohen, L. L. 265
 Collette, H. S. 326
 Columbus Bolt Works Co. 436
 Conover-Overkamp Machine Tool Co. 326
 Consolidated Car Heating Co. 153
 Continental Car & Equipment Co. 326
 Continental Car Co. 326
 Continental Piston Ring Co. 436
 Cook, Thomas R. 436
 Crawford, H. C. 381
 Davis Manufacturing Co. 326
 DeRevere, A. W. 326
 Dearborn Chemical Co. 152, 265
 Dearborn Steel & Iron Co. 206
 Detrick & Harvey Machine Co. 53, 493
 Detroit Graphite Co. 436
 Dilley Foundry Co. 326
 Disston & Sons, Henry 265
 Disston, William 265
 Dixon Crucible Co., Joseph 206, 265
 Dixon, Joseph F., Jr. 326
 Doy, H. M. 327
 Edgar Allen American Manganese Steel Co. 326
 Edison Phonograph Works 53
 Edison Storage Battery Co. 53, 152, 381*, 493, 551, 601
 Edwards, E. T. 437
 Electric Storage Battery Co. 601
 Ellis, Charles B. 493
 Evans, M. A. 493
 Evans, W. H. 602
 Everett, Edward A. 493
 Fairbanks, Morse & Co. 381*
 Fairmont Gas Engine & Railway Motor Car Co. 152
 Fairmont Machine Co. 152
 Fisher, W. H. P. 551
 Flint & Chester, Inc. 436
 Fogg, J. W. 206
 Forged Steel Wheel Co. 265
 Franklin Railway Supply Co. 551, 649, 650
 Galena Signal Oil Co. 265
 Geier, Fred A. 326
 General Lead Batteries Co. 152
 Genzer, J. Douglas 327
 Giesel Co., The Henry 103
 Gillispie, R. W. 649
 Gisholt Machine Co. 326
 Given, John R. 436
 Gossen, H. 436
 Gould, J. O. 152
 Graff, E. D. 551
 Grigg, Frank N. 103
 Grip Nut Co. 493
 Grove, E. M. 551
 Grulik-Henderson Co. 265
 Hall, F. A. 206
 Hamill, Laurence 326
 Hamill-Hickox Co. 326
 Hardy, W. E. 601
 Hart, Eli Stillson 53*
 Harvey, Alexander 53
 Harvey Co., The 382
 Hayton, John 436
 Hawley, Henry S. 437
 Hem, H. O. 649
 Hequenbourg, H. C. 53*
 Hewitt Co. 265
 Hibbits, F. N. 436
 Hickox, W. B. 326
 Higging, Samuel 103
 Hillis & Jones Co. 601
 Hodges, William Sterling 327
 Holladay, Negstad & Co. 493

Supply Trade Notes—(Continued)

Huey, A. H. 265
 Huey, W. B. 265
 Hunt Co., Inc., C. W. 265
 Hydraulic Press Mfg. Co. 103, 551, 602
 Ideal Die & Tool Co. 436
 Independent Pneumatic Tool Co. 381
 Ingersoll-Rand Co. 381
 Inland Steel Co. 493
 Irwin, F. K. 326
 Jackman, A. E. 53
 Jennings, R. E. 206
 Johns-Manville Co., H. W. 152, 265
 Johnson, A. S. 152
 Kalamazoo Railway Supply Co. 436
 Kearney & Trecker Co. 103
 Keuffel & Esser Co. 493
 Kincaid Stoker Co. 381
 Kinney, W. H. 152
 Lackawanna Steel Co. 206
 Latrobe Electric Steel Co. 437
 Leeds, E. L. 206
 Lehigh Valley 436
 Leonard, H. Ward 153
 Lidstone, Charles 326
 Lima Locomotive Corp. 265
 Linde Air Products Co. 265
 Little, C. B. 649
 Llewellyn, J. S. 152
 Llewellyn, Paul 152
 Loco Light Co. 551
 Locomotive Finished Material Co. 103
 Locomotive Pulverized Fuel Co. 206, 265
 Locomotive Stoker Co. 436
 Love, L. S. 436
 Lubricating Metal Co. 327
 McAdam, A. D. 206
 McAllister, J. R. 601
 McConway & Torley Co. 552*
 McElhany, Charles B. 152, 437
 McElroy, J. F. 153
 McFarland, J. A. 153*
 McIntyre, F. W. 381
 McKenna Brothers Brass Co. 437
 McKenna, Roy C. 437
 Manning, Maxwell & Moore, Inc. 54*, 206, 265, 326
 March, P. G. 326
 Merwin, G. T. 152
 Mesker, L. H. 103
 Mesta Machine Co. 493
 Meyran, L. A. 326
 Middleton, W. T. 265
 Midvale Steel Co. 552
 Milburn Co., Alexander 382
 Millsapps, W. K. 493
 Mitchell, H. G. 381
 Modern Tool Co. 436
 Mohr, Joseph 207
 Molleson Co., G. E. 601
 Montgomery, H. M. 381
 Moore, C. A. 54*
 Moore, J. Turner 327
 Moore, M. G. 327
 Morse, C. H., Jr. 381*
 Mudge & Co. 436
 Muhlfield, J. E. 265*
 Munch, A. 265
 National Boiler Washing Co. 551
 National Carbon Co. 649
 National Equipment Co. 649
 National Hose Coupling Co. 436
 Newbold, R. M. 381
 Newhall, David 551
 New York Air Brake Co. 601
 Niles-Bement-Pond Co. 206, 326, 327, 381
 Niles Tool Works Co. 327
 Normoyle, D. J. 326
 Norton, A. O., Inc. 436
 Nova Scotia Steel & Coal Co. 493
 Oatman, Paul B. 436
 Osborne, L. A. 327
 Ostrander, A. E. 602
 Ottinger, W. S. 152
 Overkamp, C. H. 326
 Pacific Great Eastern Equipment Co. 326
 Parsons Co., B. W. 265
 Passino, A. J. 326
 Paterson, R. A. 436
 Peabody, G. H. 206
 Peacock, M. A. 382
 Pennsylvania Steel Co. 602, 649
 Peters, F. R. 649
 Pittsburgh Steel Car Co. 326
 Pollard, H. K. 326
 Pool, G. C. 649
 Poole, A. J. 265
 Poor, F. H. 649
 Powdered Coal Engineering & Equipment Co. 381
 Poyer, C. E. 152
 Pratt & Whitney 206, 493, 551
 Preston, H. E. 326
 Pullman Company 53
 Pyrene Mfg. Co., The 326
 Q & C Co. 152, 551, 649
 Quince, C. F. 152
 Railroad Supply Co. 437
 Railway Appliances Co. 493
 Railway Economy Device Co. 551
 Railway Engineering & Equipment Co. 326
 Railway List Co. 153*
 Railway Periodicals Co., Inc. 552
 Ralston Steel Car Co. 206
 Ramby, George W. 326
 Rapp, J. P. 265
 Reading-Bayonne Steel Casting Co. 326

Supply Trade Notes—(Continued)

Reading Steel Casting Co. 326
 Reiss, Geo. T. 327
 Replogle, J. L. 153*, 649
 Republic Iron & Steel Co. 436
 Rhoads, C. H. 152
 Riddell, G. F. 493
 Robinson & Son Co., Wm. C. 103, 327
 Roberts, H. M. 551
 Roberts & Schaefer Co. 437
 Robertson, W. Spencer 436
 Roebbling's Sons Co., John A. 103
 Roger Ballast Car Co. 53*
 Rohman, H. D. 650*
 Rosser, W. W. 206*
 Rowell, B. C. 382
 Ryan, Edward 436
 Ryan, Galloway & Co. 436
 Ryerson & Son, Jos. T. 103, 152, 493, 551
 S K F Ball Bearing Co. 551, 649
 St. Louis Surfer & Paint Co. 152
 Safety Car Heating & Lighting Co., The 53, 207, 381
 Safety First Manufacturing Co. 265
 Sargent, William D. 326
 Schoen, C. T. 265
 Scott, H. B. 326
 Scott, W. A., Jr. 326
 Scullin Steel Co. 436
 Seabrook, H. H. 103
 Seaton Foundry Co., John 103
 Sessions, H. H. 207*
 Sheene, H. R. 53
 Sherburne, Charles William 327
 Sherritt & Stoeer Co., Inc. 265, 436
 Sherritt, M. A. 265
 Smith, Bertram 493
 Smith, Robert M. 493*
 Smith, S. H. 601*
 Smith-Totman Co. 602
 Smith-Ward Brake Co., Inc. 436
 Southward Foundry & Machine Co. 207
 Spalding, Charles 326
 Spangler, J. M. 649
 Sprague Electric Works 206, 601
 Spray Manufacturing Co. 493
 Standard Brake Shoe & Foundry Co. 326
 Standard Chemical Co. 53
 Standard Coupler Co. 207*
 Standard Heat & Ventilation Co. 103
 Stark Rolling Mill Co. 206
 Stevens-Duryea Co. 327
 Stevens Arms & Tool Co., J. 327
 Superior Car Roofing Co., The 206
 Symington Co., T. H. 206*
 Taylor, F. W. 206*
 Taylor, R. L. 552
 Taylor Wharton Iron & Steel Co. 326
 Terry Steam Turbine Co. 207, 326, 382
 Thompson, H. G. 381*
 Titan Storage Battery Co. 152
 Toledo Scale Co. 649
 Towne, H. R. 207*
 Traver, William H. 265
 Trent, J. H. 152
 Tripp, G. E. 382
 Tucker, A. Q. 551
 Union Fibre Co. 326
 Union Switch & Signal Co. 53
 United Railway Specialties Co. 436
 United States Light & Heat Corporation 436
 United States Light & Heating Co. 265
 U. S. Metal & Manufacturing Co. 326, 602
 Valentine Varnish Co. 152
 Van Ausdall, W. 551
 Van Patten, E. B. 649
 Vanadium-Alloys Steel Co. 437
 Varney, H. A. 602
 Wainwright, Jos. 326
 Ward Leonard Electric Co. 153
 Waugh, W. D. 436
 Weber & Co., W. H. 601
 Wells Light Manufacturing Co. 382
 Westinghouse Electric & Manufacturing Co. 103, 265, 327, 381, 382, 436, 602
 White & Co., Inc., J. G. 326
 Whiting Foundry Equipment Co. 326
 Willard Storage Battery Co. 381, 436
 Willson & Co., Inc., T. A. 53
 Wilson, Alexander 551
 Wilson, G. C. 381
 Wilson, L. F. 153*
 Winship, E. E. 326
 Wood, Walter M. 265
 Wright, David A. 103
 Wright, J. S. 265
 Yale & Towne Mfg. Co. 103, 206, 207*
 Yardley, C. B., Jr. 103, 327
 Zelnicker, Walter A. 53
 Zug Iron & Steel Co. 152
 Swiss railways dynamometer car 606*

T

Tail braces, Repairing worn, by H. C. Spicer 90*
 Talc as a lubricant 148*
 Tank design, Good features of, by Walter R. Hedeman 224*
 Tank hose strainer with automatic cleaning device, Barco 1190*
 Tank valve castings, Finishing, by W. W. Elfe 82*
 Tanks, Constructing locomotive, Boiler Makers' convention 315
 Tap, Collapsible, Modern Tool Co. 544*
 Taylor, C. S., Making good car inspectors 624

Page numbers under 1,000 refer to Railway Age Gazette, Mechanical Edition; those over 1,000 refer to the Daily Railway Age Gazette. *Illustrated article; †short non-illustrated article or note; ‡communication

Teff, Jesse E., Handling work reports at engine houses.....	31*	Trucks, Four wheel, for passenger cars, by R. V. Wright.....	569*	Weather strips, Cloth-lined metal, Athey Co.....	260*
Tempering tools with the electric furnace.....	590	Trucks, Length of radius bar for two-wheel, by L. R. Pomeroy.....	290*	Wedge bolt, Locomotive, Wine Railway Appliance Co.....	200*
Templeton, Kenly & Co., Emergency jack with adjustable base.....	432*	Truss rods on steel members, by Theo. F. H. Zealand.....	4†	Wedge bolt, Removable, H. E. Oplinger.....	591*
Tender derailments, by G. W. Lillie.....	58†	Truss rods on steel sills.....	56‡	Welding, Answers to some questions on electric, by J. F. Lincoln.....	195
Tender, Southern steam, locomotive.....	613*	Tubes, Repairing locomotive boiler, by N. H. Ahstioh.....	83*	Welder, Constant current electric, Lincoln.....	490*
Tenders, Calibration charts for Vanderbilt.....	563*	Tubes (see Boiler tubes).		Welding copper and copper alloys by acetylene methods, by J. F. Springer.....	367
Tenders, Inspection of.....	284	Turnbuckles, Dies for forming, Blacksmith's convention.....	476*	Welding and cutting outfit, Portable oxy-acetylene, N. Y. C.....	592*
Test committee report, Painters' convention Test department, Pennsylvania.....	329‡	Turner, Walter V., Electro-pneumatic brake, T. E. A. convention.....	507	Welding and cutting, Possible substitute for acetylene in.....	529
Test department, Pennsylvania, by C. D. Young.....	332*	Turret lathe chucks, Special, by W. W. Elfe.....	196*	Welding and cutting torch, Combination oxy-acetylene, Imperial.....	320*
Tests, Data from Monon coal consumption.....	617*			Welding, Electric, Blacksmiths' convention.....	476*
Tests of exhaust ventilators.....	235*			Welding, Electric, in boiler maintenance, Boiler Makers' convention.....	312
Tests and specifications of materials.....	1355‡			Welding equipment, Oxy-acetylene, Imperial Brass Co.....	197*
Tests and specifications for materials.....	1373*			Welding, Flue, Blacksmiths' convention.....	471*
Tests, Road, for determining front end conditions, by E. S. Barnum.....	454*			Welding, Oxy-acetylene, General Foremen's convention.....	425
Testing devices for air brakes, L. & N.....	470			Welding, Oxy-acetylene for boiler work, Boiler Makers' convention.....	309
Thawing house for frozen cars, C. & W. I. Thill, E. J., Piece work and its advantages.....	122			Welding, Restrictions on autogenous.....	1207‡
Thomas, F. H., Training official material and journeymen apprentices.....	370			Wells, William, Boiler washing and filling system for small roundhouses.....	251*
Throttle valve seat reamer, Tool Foremen's convention.....	411*			West Disinfecting Co., Sanitary toilet.....	1353
Tinware, Standardization of, M. M. convention.....	1274*			Western Pacific, Motor drive for Bradley helve hammer.....	184*
Tinware, Standardization of, Storekeepers' convention.....	290			Western Railway Club (see Meetings).	
Tire flanging tool, Double, by R. E. Brown.....	308*			Westinghouse Electric & Manufacturing Co., Magnet for removing metal from flesh.....	148*
Tire heater.....	638†			Wheel failures, Car.....	1355‡
Tire lifting hook, by B. N. Lewis.....	134*			Wheels, Car, M. C. B. convention.....	1340
Tires, rods and wheels, General Foremen's convention.....	420			Wheels, Chilled iron.....	578
Toilet, Sanitary, West Disinfecting Co.....	1353			White American Locomotive Sander Co., Inc., Locomotive sander.....	1353*
Tolin, J. J., Freight car repairs under piece work system.....	347			Whitford, W. S., Device for placing air pumps.....	581*
Tonnage rating and scientific train loading, T. E. A. convention.....	502			Whitford, W. S., Method of securing steam gages.....	364*
Tool failures, Cause of high speed steel, by Geo. J. Brunelle.....	369			Whitford, W. S., Pneumatic flue cutter.....	86*
Tool Foremen's Association (see American Railway Tool Foremen's Association).				Whitford, W. S., Portable rivet forge and blow torch.....	191*
Tool holders, Boring, Rigid.....	595*			Williams, J. S., Improved performance with old type coaling facilities.....	66
Tool holder for high speed steel cutters, Keystone.....	1226*			Williamson, H. C., Metal hand saw.....	488*
Tool system, Illinois Central, by Owen D. Kinsey.....	361*			Willmarth Tool Works, Radial drill.....	45*
Tool steel, Factors in hardening, by J. A. Mathews et al.....	243*			Willson & Co., T. A., Eye protectors for machinists and grinders.....	48
Tools, Grinding and distribution of, Tool Foremen's convention.....	415			Wine Railway Appliance Co., Wedge bolt.....	200*
Tools, Machine steel for small, by Owen D. Kinsey.....	189*			Winterrowd, W. H., First 4-8-2 type locomotive in Canada.....	556*
Tools tipped with high speed steel.....	590*			Wolcomb, Harvey De Witt, "Big Bill" Agnew and "Blue Monday".....	533
Tools, The value of home-made.....	604‡			Wolcomb, Harvey De Witt, "How the Old Man Beat Them to It".....	639
Towel receptacle for sleeping cars, Can. Nor.....	461*			Wolf, E. H., Rotary four-way valve.....	542*
Tractine effort, Diagram for determining percentage of maximum, by L. R. Pomeroy.....	453*			Wolfgang, W. H., The bonus system.....	108‡
Trailer bearings, Hot.....	565*			Wood, Charles E., No "Greatest Defect" in box cars.....	20
Train lighter, axle driven, Northern Pacific steel cars.....	522*			Wood worker, Variety, American Saw Mill Machinery Co.....	1281*
Train lighting, M. C. B. convention.....	1386*			Work reports, Handling, at engine houses, by Jesse E. Tefft.....	31*
Train pipe compensating valve, California Valve & Air Brake Co.....	94*			Workmanship, The economy of good.....	156‡
Train signal, Operation of the pneumatic, Air Brake convention.....	296*			Wrecker yoke, Safety, J. W. Riley.....	547*
Trains, Rough handling of passenger.....	1287‡			Wright, John D., Steel car design from a protection standpoint.....	525
Transportation, Cost of conducting.....	1288‡			Wright, R. V., Four wheel trucks for passenger cars.....	569*
Trap door, Extensible vestibule, Pennsylvania.....	430*			Wright, R. V., How do you select your men?.....	387
Trap door, Sliding vestibule, O. M. Edwards Co., Inc.....	1320*				
Traveling Engineers' Association convention	499*				
Traveling Engineers' Association (see Meetings).					
Treacy, John, Device for forming sill steps.....	641*				
Triple valves, Cleaning, C., B. & O.....	568*				
Triple valve, Diaphragm-operated, California Valve & Air Brake Co.....	92*				
Trolley, Electric crane, Northern Engineering Works.....	97*				
Truck, Cole-Seoville.....	216†				
Truck brasses, Finishing car and engine, by R. E. Brown.....	193*				
Truck, Erie steel suburban cars.....	358*				
Truck frames, Rolled steel, American Car & Foundry Co.....	429*				
Truck, Hot trailer bearings.....	565*				
Truck, Leading, C. P. R., 4-8-2 type.....	558*				
Truck, Long Island steel suburban car.....	404*				
Truck side frame, Cast steel, Benners.....	645*				
Truck side frame, Experiments to determine the stresses in.....	127*				
Truck side frame, Forged steel, Forsyth.....	1318*				
Trucks, Car, M. C. B. convention.....	1388*				
Trucks, Design of.....	625*				

Page numbers under 1,000 refer to *Railway Age Gazette*, Mechanical Edition; those over 1,000 refer to the *Daily Railway Age Gazette*. *Illustrated article; ‡ editorial; † short non-illustrated article or note; ‡ communication.

Railway Age Gazette

MECHANICAL EDITION
INCLUDING THE
AMERICAN ENGINEER

PUBLISHED ON THE FIRST THURSDAY OF EVERY MONTH BY THE
SIMMONS-BOARDMAN PUBLISHING COMPANY,
WOOLWORTH BUILDING, NEW YORK, N. Y.

CHICAGO: Transportation Bldg. CLEVELAND: Citizens' Bldg.
LONDON: Queen Anne's Chambers, Westminster.

EDWARD A. SIMMONS, *President* L. B. SHERMAN, *Vice-President*
HENRY LEE, *Secretary*

The address of the company is the address of the officers.

ROY V. WRIGHT, *Editor*

R. E. TRAYER, *Associate Editor* A. C. LOUDON, *Associate Editor*
C. B. PECK, *Associate Editor*

Subscriptions, including the eight daily editions of the *Railway Age Gazette* published in June in connection with the annual conventions of the Master Car Builders' and American Railway Master Mechanics' Associations, payable in advance and postage free:

United States, Canada and Mexico..... \$2.00 a year
Foreign Countries (excepting daily editions).... 3.00 a year
Single Copy 20 cents

Entered at the Post Office at New York, N. Y., as mail matter of the second class.

WE GUARANTEE, that of this issue 4,500 copies were printed; that of these 4,500 copies 3,695 were mailed to regular paid subscribers, 150 were provided for counter and news companies' sales, 234 were mailed to advertisers, exchanges and correspondents, and 221 were provided for samples and office use; that the total copies printed this year to date were 4,500, an average of 4,500 copies a month.

The RAILWAY AGE GAZETTE, MECHANICAL EDITION and all other Simmons-Boardman publications are members of the Audit Bureau of Circulations.

VOLUME 89

JANUARY, 1915

NUMBER 1

CONTENTS

EDITORIALS:	
Economy in Shop Operation.....	1
Car Construction in 1914.....	1
Increased Capacity in Existing Locomotives.....	1
Riveting in Steel Car Construction.....	2
Enginemen and Economy.....	2
Machine Tool Efficiency.....	2
Locomotive Development in 1914.....	2
To Committees of Mechanical Associations.....	3
New Books.....	3
COMMUNICATIONS:	
Mechanical Department Salaries.....	4
Melted Boiler Tubes.....	4
Truss Rods on Steel Members.....	4
GENERAL:	
The Steam Locomotive of Today.....	5
A Study of Spring Rigging Design.....	15
CAR DEPARTMENT:	
Lubrication of Car Journals.....	19
No "Greatest Defect" in Box Cars.....	20
Steel Coaches for the Santa Fe.....	21
Erie Caboose with Steel Center Sills.....	25
Relation of the Paint Shop to the Repair Yard.....	28
End Construction of Canadian Pacific Stock Cars.....	29
Joint Car Repair Shops at Large Terminals.....	30
Defective Box Cars.....	30
SHOP PRACTICE:	
Handling Work Reports at Engine Houses.....	31
Riveting in Steel Car Construction.....	33
Simple Furnace for Melting Brass.....	36
Beil Yoke Bearing Reamers.....	36
Forging Machine Dies.....	37
Locomotive Running Repairs.....	37
Removing Gaskets from Bullseye Lubricators.....	39
Grinding Distributing Valves.....	39
Reclaiming Bolts with Battered Threads.....	39
Removing Indentations in Superheater Smoke Tubes.....	40
Horizontal Drilling Attachment for a Radial Drill.....	40
Model Locomotive Built by Erie Apprentices.....	41
Running Repairs.....	41
Adjustable Drilling Stand.....	42
NEW DEVICES:	
Brake Shaft Drop Handle and Ratchet.....	43
A High Pressure Gas Valve.....	44
Safety Cut-Out Valve.....	44
Blower Pipe Drain Fitting.....	45
Radial Drill.....	45
Metallic Salts Pyrometers.....	46
Sanitary Drinking Fountain for Passenger Cars.....	47
Chaser Grinder.....	47
Automatic Facing Tool.....	48
Eye Protectors for Machinists and Grinders.....	48
NEWS DEPARTMENT:	
Notes.....	49
Meetings and Conventions.....	50
Personals.....	51
Supply Trade Notes.....	53
New Shops.....	54
Catalogs.....	54

Economy in Shop Operation
With a considerable part of the five per cent rate increase granted, the eastern roads will surely derive some relief from the period of depression. The public has shown that it believes the railways need assistance and has so vigorously expressed this feeling that the Interstate Commerce Commission has granted a large part of the requested increase in rates. Everything possible should be done by the railroads to keep the cost of operation to a minimum consistent with safety and efficiency. The shop men are in an excellent position to assist substantially in this respect. The careful use of material, careful workmanship and economical use of supplies are all factors that will materially contribute towards the necessary economies. Retrenchment in the mechanical department has a direct effect on the employees, and they should be made to realize that by their help money can be saved to the end that the shops will be kept in operation.

Car Construction in 1914
A most interesting feature of the figures for car construction in 1914 is the increase in the number of all-steel box cars built, the greater part of which is due to the adoption of the all-steel type of construction on the Pennsylvania Railroad. There is also a considerable increase over 1913 in the number of steel underframe box cars built, while the number of steel frame box cars falls off materially. On first consideration it might seem that the steel frame construction is losing in popularity, but there may be other explanations for the falling off. In a year of depression like the one just past many of the railroads order little or no equipment, so that the cars built are for a comparatively few roads and it is difficult to point to any definite tendency which is indicated by the construction figures. There is also an increase in the number of steel underframe passenger cars built, but most of these were built for a comparatively few roads, some of which favor this type of construction. The all-steel car preponderates, although there is a falling off in the total number of cars built. Of the wooden passenger equipment cars, the greater proportion were milk, refrigerator, and cars for other special service.—(From our Weekly Edition.)

Increased Capacity in Existing Locomotives
The ever pressing need of greater train-loads has increased locomotive dimensions and capacities so rapidly that the large locomotives of a few years ago, which the more modern equipment replaces, have developed a serious problem for the motive power and operating departments to solve. There are numbers of these locomotives which possess more capacity than is needed for way-freight or branch line service, yet in many cases it has been necessary to place them in such service, as well as in switching. Many of these engines are capable of developing a maximum tractive effort which will start very heavy trains, but are deficient in boiler capacity and are therefore incapable of economically hauling such trains for any distance. If there were some way of increasing the steam making capacity of such locomotives they could take their place in heavy main line service; in fact, such an increase in boiler capacity could very easily obviate the necessity of a road's making considerable expenditures for new locomotives of greater capacity. The difficulties attending the use of superheated steam with slide valves and the expense necessary in applying piston valve cylinders have prevented the use of superheaters in many such instances. Of the past year's locomotive development, therefore, perhaps the one of most direct interest to railways is that which has shown the possibilities of increased capacity obtainable from existing locomotives. It is now possible to apply piston valves without going to the extent of entirely new cylinder

and saddle castings, and the use of the superheater and the brick arch, even on narrow firebox locomotives, has given remarkable results in increased hauling capacity. It is therefore probable that the immediate future will see the modernizing of the large locomotives of a few years ago, in considerable numbers.—(From our Weekly Edition.)

Riveting in Steel Car Construction

Assembling and riveting are matters of the utmost importance in steel car construction and should be of general interest to all who are in any way connected with the building or repairing of steel cars. The article by H. A. Hatfield, the first part of which is published in this issue, while containing much of general interest, should be particularly interesting to those who are called upon to inspect the various processes in the construction of steel equipment. As pointed out by Mr. Hatfield the strength and rigidity of a steel car depend primarily upon the tightness of the rivets. The securing of tight rivets under the conditions usually existing in the construction of steel freight cars demands eternal vigilance on the part of the inspector, whose troubles would undoubtedly be considerably decreased if the author's suggestions relative to the proper heating of rivets and maintenance of tools were more generally observed. While the article in general does not fit the conditions found in boiler shop practice, it contains several practical suggestions which might be applied there with as good results as in the car shop. It will be published in two parts.

Enginemen and Economy

A western road which is carrying on a progressive campaign in fuel economy is making use of a diagram, in lectures to the enginemen on fuel economy, showing the amount of money spent during the past fiscal year for locomotive fuel, locomotive repairs, freight car repairs, enginemen's wages, enginehouse expenses, water, lubrication and supplies. It shows clearly the relation between each item and gives an idea of the magnitude of the different items. As an example, the cost of the fuel consumed is 175 per cent of the enginemen's wages, the cost of locomotive repairs is 116 per cent, and the cost of freight car repairs is slightly over 100 per cent. The men are shown that aside from their own wages, which are about 18½ per cent of the total amount of the items mentioned, they are more or less responsible for the expenditure of over 17½ million dollars. They are thus made to feel that they have an important part to play in the railroad game from an economic standpoint in addition to the running of the locomotives. By making a saving of only 1 per cent of this total they will save the company very nearly 4½ per cent of their wages. Economy brought home to them in this way makes a strong impression, and they all seem to be interested in the fact that they are responsible in some considerable degree for these large expenditures.

Machine Tool Efficiency

Many railway men have the idea that railway shop work is so entirely different from that performed in industrial plants that no comparison can be made between the two. To a certain extent this is true. In almost every case the railway shop finds it necessary to perform a number of different jobs on the same machine, whereas the large industrial shops have a sufficient amount of regular work so that individual machines can be kept busy on one, or at most, a few, specific jobs. By doing this it is possible for them to experiment sufficiently to find the speed and feed that will give the most economical results. But it is also true that the railway shop can, to some extent, profit by these experiments. It can apply the rate of metal cutting in many cases to its own works; it may obtain information that will show how the increased cost of new and improved machinery will be more than justified

by increased production, and, to some extent, new methods of doing work will be suggested. The manufacturers of new machines purchased should always be consulted as to how the best results may be obtained from their machine tools. Occasions have been known where high grade machines have been grossly underrated simply on account of a lack of knowledge as to what the machines will stand. The tool builders are willing to demonstrate their machines thoroughly, as it is to their best interests to have their products produce economical results and the railway shops should take advantage of this opportunity in studying how to secure more effective results in shop production.

Locomotive Development in 1914

The number of locomotives ordered in the calendar year 1914 was 1,265, which constitutes a marked falling off from 1913, when there were 3,467 ordered. The falling off in building was of course due to the general business depression, but the poor business conditions have by no means eliminated developments tending toward the improvement of the locomotive.

A year ago we referred to what is without doubt the highest development of the Atlantic type locomotive, embodied in the latest engine of that type built by the Pennsylvania Railroad. These locomotives were largely the result of long continued experiments along the lines of refinement in design and increase in boiler capacity. A number of them have been built and are in daily service hauling very heavy trains on extremely fast schedules. The same policy which resulted in the production of this Atlantic type locomotive has, during the past year, produced on the Pennsylvania a Mikado and a Pacific type locomotive which are especially noteworthy. Interchangeability of parts has been carried out in these two locomotives to a considerable extent, the boilers of the two engines being identical. On the testing plant at Altoona the Pacific type locomotive recently developed approximately 3,200 horsepower, a truly remarkable figure, and in this connection it is interesting to note that this horsepower was obtained when the locomotive was equipped with a type of exhaust tip having four internal projections, and that the horsepower obtainable with the ordinary form of exhaust tip was considerably less.

Heat treated steel takes a prominent place in the design of the Pennsylvania locomotives, and of locomotive design in general it may be said that alloy steels continue in favor for such parts as axles, crank pins, main and side rods, frames and springs.

The large locomotive is again to the fore in 1914. The Pacific type locomotives built by the American Locomotive Company for the Chesapeake & Ohio lead in point of total weight for this type, this being 312,600 lb., while the maximum tractive effort of 46,600 lb. developed by these engines is also the greatest for this type. The heaviest locomotive of the Mikado type of which we have record is also a Chesapeake & Ohio engine and weighs 322,500 lb. The Baldwin Locomotive Works built during the year for the Baltimore & Ohio, a 2-10-2 type locomotive which has a total weight of 406,000 lb., and is the heaviest locomotive ever built on a single set of drivers. The world's record for large locomotives was again broken by the construction for the Erie Railroad by the Baldwin Locomotive Works of a 2-8-8-8-2 type, Triplex compound articulated locomotive using the weight of the tender for adhesion and having a total weight of 853,000 lb. This locomotive has a theoretical maximum tractive effort of 160,000 lb. and has hauled a train of 251 loaded cars weighing 17,912 tons. A few locomotives of the Mountain, or 4-8-2 type, were built during the year, but they are intended for service under special conditions and there does not seem to be any general tendency to go beyond the Pacific type for hauling heavy passenger trains.

The mechanical stoker has taken a prominent place in increasing locomotive capacity, and there are a number of locomotives now in service which would not have been built had it not been

possible to fire them by mechanical means. On large hand-fired locomotives the use of coal pushers in the tender, for moving the coal forward within the reach of the fireman, has greatly increased.

During the year experiments have been completed resulting in the successful use of powdered coal in locomotive fireboxes, and while the results of these experiments are not yet available it is probable that when published they will prove of very considerable interest and value.

The large locomotive is likely to continue in favor in new construction, although it may be doubted that the two-cylinder type can be carried much beyond present dimensions because of limitations in clearance. The possibilities in the use of three cylinders were brought out recently in a discussion before the American Society of Mechanical Engineers by J. B. Ennis, chief mechanical engineer of the American Locomotive Company, and it would not be surprising to see steps taken in the near future toward developing large locomotives with this cylinder arrangement. With few exceptions the compound locomotive has gained nothing in favor during the past year, although the Mallet type continues in use for the particular classes of work for which it is suited, and it is of special interest to note that a large locomotive of this type which was built by the American Locomotive Company in 1912 for the Virginian Railway has developed in service a horsepower somewhat over 3,000. This power is noteworthy when it is considered that it was necessarily developed at low speed.

For the future it may be said that further economies will probably develop from superheating, and while the use of feed water heaters in America has thus far been only of an experimental nature, the results obtained are promising and would seem to indicate its development before long toward an extensive use. Considered from all standpoints the locomotive development of the immediate future will probably continue along the lines of increased capacity through the means of refinement in design and the application of economy producing features and those which tend directly to increase boiler capacity.—(From our Weekly Edition.)

**To Committees
of Mechanical
Associations**

At this time of the year, about midway between the annual conventions of the various railway mechanical associations, attention of the members of the committees appointed to prepare reports for the 1915 meetings should be called to the fact that, if they are not already doing so, it is time for them to take an active interest in the work which has been assigned to them. Too often the tendency is to postpone such matters until the last minute, a report then being hurriedly compiled just in time to present to the convention. Usually in such cases it is based on an incomplete investigation. Railway men are very busy, and this is just the reason such matters should be started early. The life and standing of any railway association depends entirely on the quality of the work it does, and the members of committees are under definite obligations to the other members of the association to submit reports that will be of material benefit to them and to the association as a whole.

The higher railway officers watch the progress and work of the associations in order to know whether or not it is worth while to send their men to the conventions. The larger associations are finding it necessary to rely on some of the minor associations for investigations that they have not now time to handle. The responsibility of the minor associations is therefore increasing, and it is the duty of every committee member to assume his share of this responsibility. In too many cases the chairmen of the committees do all the work. This is not fair to them, nor is it fair to the association, for under such circumstances the report gives only one man's point of view. Every committee member should give the best he has and feel the same responsibility as the chairman. Carefully study the

subject assigned and get all the information possible from every available source. Get busy now; send your letters of inquiry out so that there will be sufficient time to carefully analyze the replies and get additional information when necessary. Make your 1915 convention the best in the history of the association.

NEW BOOKS

Proceedings of the American Railway Tool Foremen's Association. Compiled and published by Owen D. Kinsey, secretary of the association, Chicago, Ill. 145 pages, 6 in. by 9 in. Bound in paper.

This book is the official report of the sixth annual convention of the American Railway Tool Foremen's Association, which was held in Chicago, July 20 to 22, 1914. Among the most important subjects considered are Tool Room Grinding, Safety as applied to Grinding Wheels, Distribution Systems of Shop Tools, and Special Tools for Drilling, Reaming and Milling, the latter subject including considerable information regarding the work that is being done at the Burnside shops of the Illinois Central. The book is neatly illustrated and contains valuable information.

Proceedings of the International Railroad Master Blacksmiths' Association. Compiled and published by A. L. Woodworth, secretary and treasurer, Lima, Ohio. 296 pages, 6 in. by 9 in. Bound in cloth.

The twenty-second annual convention of the International Railroad Master Blacksmiths' Association was held in Milwaukee, August 18 to 20, 1914. This publication of the proceedings of that convention includes papers on Frame Making and Repairing, the Heat Treatment of Metals, Spring Making, Oxy-Acetylene and Electric Welding, and other subjects of interest to blacksmiths. A number of shop kinks were also included which show economical methods adopted by various members for performing routine railroad blacksmith work. Addresses by H. E. Manchester, J. F. DeVoy, and J. J. Hennessey, of the Chicago, Milwaukee & St. Paul, are also included.

Compressed Air. By Theodore Simons, E. M., C. E., Professor of Mining Engineering, Montana School of Mines, 167 pages, 6 in. by 9 in. Illustrated. Bound in cloth. Published by the McGraw-Hill Book Company, 239 West Thirty-ninth street, New York. Price \$1.50.

The author's purpose in the preparation of this treatise was to give the student and general reader such an insight into the principles underlying the production, transmission and use of compressed air as to enable him to comprehend the operation of the various appliances and to judge of their merit. The book is divided into four parts, the first three dealing with the production, transmission and use of compressed air, the fourth containing descriptions of compressors and accessories. The whole subject is treated theoretically, the development of the various formulas which form the basis of compressed air calculations being gone into in considerable detail. Interspersed throughout the text are concrete examples which are worked out in detail. By carefully following these through the student has a means not only of checking his understanding of the principles involved, but is in a measure brought to a realization of the physical conditions represented by the symbols in the formulas. Higher mathematics has been sparingly used, its principal application being in the development of horsepower formulas for air compression and expansion. In Part IV several compressors and compressor appliances are described, this part of the text being well illustrated with photographs. It is not extensive enough, however, to do more than give the reader a general knowledge of the various methods of applying the principles set forth earlier in the book. A number of tables are contained in an appendix for convenience in the practical application of formulas.

While the book is elementary throughout, containing brief statements of all the fundamental laws involved, its greatest field will be found among engineers or engineering students whose previous education has given them a knowledge of these laws. Such readers should be able to obtain a thorough understanding of the problems involved in air compression and its use.

COMMUNICATIONS

MECHANICAL DEPARTMENT SALARIES

COUNCIL BLUFFS, Iowa.

TO THE EDITOR:

There are railway mechanical department officers in the United States having under their charge as many as 4,000 shop men, 500 locomotives, 40,000 cars, as well as monthly pay rolls of \$100,000, besides many other responsibilities, and as compensation they receive the munificent salary of \$300 a month.

Now to be reasonably competent to hold such a position, a man must start as a lad of 15 or 16 years of age, work hard, read much, and be especially intelligent. Then, if he is fortunate enough, he may be appointed, at, say, 40 years of age to such a position. He must be familiar with all branches of railroad work, must furnish advice on all technical subjects and his work is a constant grind with little or no opportunity for promotion but decided possibilities of "losing out" for reasons beyond his own control.

Such inadequately compensated mechanical officers are among the sources of greatest extravagance of railroads today. The better class of men go to other livelihoods, where not only more money and glory are to be obtained, but greater peace, happiness, and satisfaction as well.

Such niggardly compensation of railway officers is very expensive in the end.

F. J. MILLER.

MELTED BOILER TUBES

CLIFTON FORGE, Va.

TO THE EDITOR:

I have read with a great deal of interest the communications concerning melted boiler tubes in the August and November numbers of the *Railway Age Gazette, Mechanical Edition*, and it calls to my mind a similar experience with which we were confronted some time ago.

The locomotive in question had been in yard service in a district where the boiler feed water contained a great deal of scale-forming matter, and when placed in the roundhouse for repairs it was decided to build a light wood fire in the firebox, with the idea of possibly ridding the firebox sheets of the heavy scale. In a very short time my attention was called to the red hot condition of the barrel of the boiler. The front was removed, and we found that the tubes had melted in two and that the inside of the boiler, particularly the front end, resembled an iron furnace.

Someone has advanced the theory that this tremendously hot fire is accounted for by using wood which contained a great deal of rosin, which, when the fire was built, passed up and was deposited in the tubes, and did not ignite until the fire in the firebox attained a high temperature. There being no water in the boiler, and the tubes being thin, it did not take a great deal of heat to burn them in two. It is also said that cases are on record where coal running high in volatile matter, such as Pocahontas, would deposit a soot on the inside of the tubes, which, when the temperature became sufficiently high, would ignite and burn fiercely. This deposit is more noticeable in stacks on stationary plants, where flames 40 or 50 ft. high are often seen issuing from the stack.

I do not attach much importance to the former theory, as the wood used in building the fire in this engine contained very little, if any, rosin, and granting such as being the case I do not believe that it could have been deposited in the tubes, as it would surely have burned, being of a low flash point. The latter explanation does not seem reasonable, as I do not believe that the tubes in this engine contained enough soot to create such an intensely hot fire. It is my opinion that the fire was caused by a great quantity of wood pulp igniting in the boiler,

this pulp having been placed there by the engine crew to stop leaks.

If anyone has any suggestion to offer as to what caused the tubes to burn in this engine I would be glad to hear from him.

E. A. MURRAY,

Master Mechanic, Chesapeake & Ohio.

TRUSS RODS ON STEEL MEMBERS

HARVEY, Ill.

TO THE EDITOR:

The editorial on British Steel Coaches in the October number contains a criticism of the use of truss rods on steel under-frame sills. No doubt there are good reasons why truss rods are not to be desired on steel members, but the reason given in the editorial does not appeal to the writer. When applied to a sill the truss rod and sill together become a truss, the sill being the compression member and the rod the tension member, both being without tension or compression with no load, and the tension and compression being equal when a load is applied. An initial tension in the rod is not necessary in order that it do its share. Truss rods are frequently used on steel members in other lines of work to good effect. A truss rod would be more effective on a steel sill than on a wooden one for the reason that the compression member of the truss would not shorten, due to drying out or by compressing at the truss rod anchors, as is the case with a wooden sill.

THEO. F. H. ZEALAND.

PAINTING PATTERNS.—The practice of painting patterns to indicate the parts of a casting which are to be machined and those to remain rough has been followed in steel foundries for some time. It is learned that a similar practice is gaining application in gray-iron foundries. The parts of a pattern corresponding to parts requiring no machine work are tinted gray, while the parts which are to be machined are painted yellow, with the parts of the pattern indicating the location of cores in red. Castings are sometimes spoiled because the molder does not know what part is to be finished in the shop.

CHEMICAL PROPERTIES OF RAIN WATER.—It is believed that water as it leaves the clouds is in a practically pure condition, and that the first opportunities for its contamination arise immediately following the beginning of its descent to the surface of the earth. In falling through the atmosphere, either as rain or otherwise, it takes up certain substances. Naturally these substances taken up are dependent upon the substances contained in the atmosphere through which it falls, which in turn are to a large extent due to the industrial conditions existing upon the surface of the earth. But there is one substance always present in the air, and that is carbon dioxide (CO₂) or carbonic acid gas. In a district where bituminous coal is the chief fuel, and where this fuel is largely impregnated with sulphur, which is the case generally with the middle states bituminous coal, the sulphur, in the process of combustion, is also converted into another gas just the same as is the carbon into CO₂ gas. This sulphur gas naturally impregnates the atmosphere and is dissolved by water falling through the air, and eventually converted into sulphuric acid. Sulphuric acid is of such a character that when in even a weak solution in water it will dissolve metallic iron very rapidly. There is also present in the atmosphere, at all times, another class of substances commonly known as the ammonia class. The atmosphere carries some of this in practically all neighborhoods at all times, consequently more or less of this class of substances becomes a part of the impurities contained in natural waters. Assuming now that the water has passed down through the atmosphere and has reached the immediate surface of the earth, it has taken up some carbon dioxide, some ammonia, undoubtedly some sulphur gases, and probably some oxygen.—*W. A. Converse, before the Railway Club of Pittsburgh.*

THE STEAM LOCOMOTIVE OF TODAY

Discussion at Annual Meeting of the American Society of Mechanical Engineers, December 2, 1914

On page 571 of the November, 1914, issue we published the report of the sub-committee of the Railroad Committee of the American Society of Mechanical Engineers which was presented at the annual meeting of the society, held in New York, December 2, 1914. In the following pages are given extracts from the discussion on Boiler Design, Fan Drafting of Locomotives, Front Ends and Draft Appliances, Combustion, What the Stoker Has Done for the Locomotive, Superheaters, Feed Water Heating, Heat Treated and Alloy Steels and Possibilities of the Future.

BOILER DESIGN IN RESPECT TO HEATING SURFACE

F. J. Cole, Consulting Engineer, American Locomotive Company:—In recent years, locomotives have increased so much in dimensions, weight and power that methods employed in the past are no longer adequate in proportioning the grate, heating surface, length and diameter of tubes, etc., or to predetermine how best a locomotive boiler may be designed to suit certain requirements, the type, tractive effort and limitations of weight being known.

The size of cylinders is usually fixed by the permissible axle load allowed upon the track or bridges, in connection with the type, the diameter of the driving wheels, the boiler pressure and the factor of adhesion. After these fundamental features are decided upon, the boiler proportions must be outlined to see whether the required amount of heating surface can be obtained without exceeding the limits of weight.

There are two general questions involved in the consideration of this subject, namely, how many pounds of steam per hour are required to supply the cylinders in order to develop the maximum horsepower; and what proportion of grate, firebox and tube heating surface will best produce this amount of steam.

The locomotive, unlike most steam plants, varies in the speed and power developed. It must be able to run at any intermediate speed between starting and its full velocity and at the same time develop all degrees of tractive effort within its capacity. At slow speeds the maximum pull must be exerted in order to start the trains easily, and for this reason the live steam is admitted to the cylinders during 80 to 87 per cent of the stroke. As the speed increases it is necessary to reduce the admission period, thereby increasing the expansion of the steam; therefore for any speed there is some point for the valves to cut off the live steam, at which the engine will develop its maximum power. There is also some minimum velocity at which the full horsepower of the locomotive is attained; after this velocity is reached the horsepower remains constant or slowly decreases. This critical point may be taken at 700 ft. to 1,000 ft. per minute piston speed.

Instead of the old arbitrary method of designing locomotive heating surface by cylinder ratios, the idea of using the cylinder horsepower suggested itself as forming a very desirable basis for the heating surface, grate area and tube area. Curves were prepared from the most recent available data showing speed factors or drop in M. E. P. in relation to velocity. With saturated steam the average maximum horsepower is reached at about 700 ft. piston speed per minute, speed factor .412; constant horsepower is obtained at 700 to 1,000 ft. piston speed, and the horsepower decreases slightly at higher velocities for average conditions when engines are especially constructed for the highest speeds. For superheated steam the average maximum horsepower is reached at 1,000 ft. piston speed, speed factor .445, and constant horsepower at higher speeds. Because the horsepower is based on piston speeds, the stroke and diameter of wheels are

omitted in the following figures, the calculation becoming by cancellation:

$$\frac{.85 P \times .412 \times 1,000 \times 2 A}{33,000} = \frac{1.7 P \times .412 \times A}{33} = .0212 \times P \times A$$

$$\text{HP.} = .0212 \times P \times A$$

in which A = area of one cylinder in square inches.

P = the boiler pressure.

.412 = speed factor.

In a similar manner the horsepower calculation for superheated steam becomes:

$$\text{HP.} = .0229 \times P \times A$$

using .445 as the speed factor.

The maximum horsepower can sometimes be increased when the locomotive is operated under the most favorable conditions. It is considered safer and better practice, however, to take figures which represent average conditions rather than the abnormal and unusual figures obtained when all conditions are most favorable.

The horsepower basis affords many additional advantages in designing locomotives. For instance, in determining the maximum amount of water and coal required per hour, the size of the grate is found to be proportional to the amount of coal that can be burned to the best advantage, to be varied according to the quality. Knowing the amount of coal required per hour directs attention to the question of hand firing or the use of a mechanical stoker. Knowing the amount of water evaporated per hour determines the location of water stations, size of tender tank, the size of injectors and safety valve capacity, also the size of steam pipes and other features of the boiler. Through the stack a mixture of gas and exhaust steam is ejected at substantially the same velocity for all locomotives in similar service, and proportional to the amount of coal burned. For this reason the area of the stack may be taken as proportional to the maximum amount of coal burned per hour in the firebox.

As a result of the investigations, conclusions have been arrived at as follows:

Firebox Evaporation.—An evaporation of 55 lb. per square foot of firebox heating surface, combustion chamber and arch tubes has been adopted. The greater absorption of heat by the firebox than by the rear portion of tubes per unit of area is largely due to radiant heat. This varies as the square of the distance from the surface of the fire to the sheets separating the gases from the water. Again, it is probable that within certain limitations the amount of heat absorbed is independent of the heating surface and is a function of the grate area or the area of the bed of live coals. Assuming that there is sufficient heating surface to absorb the radiant heat, it is probable that very little additional heat will be absorbed by increasing the firebox heating surface. It therefore follows that the relatively greater area of the fire in proportion to the absorbing surface in wide firebox locomotives is more efficient than in the old narrow firebox.

Diameter, Length and Spacing of Tubes.—The evaporative value in pounds of water per square foot of outside heating surface has been approximately calculated for 2 in. and 2¼ in. tubes, and for superheater flues 5¾ in. and 5½ in. The range of length is 10 to 25 ft., and the spacing 9/16 in. to 1 in. The best data available shows that the evaporative value of a tube or flue varies considerably with differences in length, diameter and spacing. The curves of temperature compared with length have been used as a basis for determining the evaporation for different lengths of tubes and flues. The rate of evaporation on this basis will vary directly as the difference

of temperature of the tube or flue gases and that of the steam contained in the boiler.

Tubes and flues from 10 to 24 ft. long, spaced 9/16 in. and 1 in. apart, outside diameter 2 in., 2¼ in. and 5/2 in. will evaporate from 7.50 to 14 lb. of water per square foot per hour.

Grate Area.—The grate area required for bituminous coal is based on the assumption that 120 lb. of coal per square foot of grate per hour is a maximum figure for economical evaporation. While 200 and 225 lb. have at times been burnt in small, deep fireboxes and the engines made to produce sufficient steam, it is wasteful of fuel and it has been found after numerous and careful tests that the evaporation per pound of coal under these conditions is very low. If, on the other hand, the rate of combustion is too slow, economical results will not be produced owing to the fact that at least 20 per cent of the coal burned produces no useful work in hauling trains, but is consumed in firing up, waiting at roundhouses or terminals, on sidetracks, or to the fact that the greater portion of the time locomotives are used at considerably less than their maximum power.

For hard coal the grates should be proportioned for a range of from 55 to 70 lb. of coal per square foot per hour, according to the grade of the fuel.

Complete tables of horsepower for saturated and superheated steam, evaporation of tubes and flues of various lengths, diameters and spacing, as well as diagrams of temperature for different flue lengths, have all been prepared to facilitate the calculations in determining the proportions of grate, firebox, tube and flue heating surface.

It must be remembered, however, that the boiler capacity for a locomotive when other things are in proportion cannot usually be made too large within the permissible limits of weight, and it can be shown by numerous tests that such increase in boiler capacity makes for considerable economy in the use of fuel and steam. For passenger service the boilers may often be made with advantage over 100 per cent.

In a general way, a boiler will have ample steam making capacity if proportioned by this method for 100 per cent, provided the grate is sufficiently large and deep so that the rate of combustion at maximum horsepower does not exceed 120 lb. of coal per square foot of grate per hour for bituminous coal of average quality. For gas coal a smaller grate may be used, but it is better practice to use the larger grate and brick off a portion at the front end in order to obtain sufficient volume of firebox for proper combustion, because nearly all modern locomotives are deficient in firebox volume.

C. D. Young, Engineer of Tests, Pennsylvania Railroad.—On the Pennsylvania Railroad it is believed that the tendency at the present time should be to increase the firebox heating surface, as it should be realized that it is of comparatively greater effectiveness at mean and low rates of working than the remaining surface of the boiler. Some few years ago when large boilers were designed the tendency was to make the ratio of the firebox to the total heating surface less than 6 per cent. This resulted in locomotives which, although efficient in evaporation, were not free steaming, as they lacked capacity unless very heavily drafted. It is my opinion that the firebox heating surface should be at least 7 per cent of the total heating surface of the boiler, in order to provide a free steaming locomotive, and that when this ratio is satisfied, good results will follow, provided the tube heating surface has been properly proportioned. When working the boiler at high rates of evaporation, however, the tube surface is fully as effective as firebox surface, and for large capacity a large tube heating surface is necessary.

We do not agree with the recent tendency toward excessively long tubes, as beyond a certain length of tube there is too great a sacrifice of boiler capacity in the interest of economy in coal. The long tube presents a very serious obstruction or resistance to the flow of the gases, and beyond

a length which appears to be about 100 internal diameters, this obstruction increases without a corresponding increase in evaporation. The locomotive with a long tube is a slow steamer and a higher draft must be furnished in order to create an active fire. This rule that the length of tube should be 100 times the internal diameter has been applied to three new classes of our locomotives with exceedingly gratifying results, and confirms the earlier experiments which were made by us upon this subject, as well as those made by M. A. Henry, of the Paris, Lyons & Mediterranean Railway of France.

FAN DRAFTING AS APPLIED TO LOCOMOTIVES

H. B. MacFarland, Engineer of Tests, Atchison, Topeka & Santa Fe.—The method of drafting a locomotive with its exhaust steam has varied in detail only during the long period of development of the steam locomotive. The basic principle is exactly that of 50 or 60 years ago. The exhaust from the engine was early utilized to produce the necessary draft and is commonly so used today.

The magnitude of the loss due to back pressure as it existed in representative locomotives on the Atchison, Topeka & Santa Fe was shown in a paper presented by the writer at the fourth annual convention of the International Railway Fuel Association* in May, 1912. The material was collected from a large number of locomotives in actual service operating under greatly varying conditions and showed conditions existing at that time. A general statement is drawn based on tests conducted on 18 different locomotives representing as many different types, working under such varied conditions as are encountered upon the Santa Fe system, with territory extending from Chicago to the Pacific Coast, and presenting at one place or another most of the conditions encountered in railway service. This statement shows that for every 100 horsepower used as actual tractive effort, there are 66 horsepower wasted through the exhaust, over 70 per cent of which may be credited to the excessive back pressure necessary to produce draft for the locomotive boiler. A study of the facts has led the writer to the consideration of a more economical method of drafting locomotive boilers.

Comparative power performance curves for locomotives 1,700 and 1,962 are shown in one of the illustrations. These curves are plotted as a result of data obtained during comparative tests on these locomotives on the third district, Arizona division, between Barstow and Bakersfield, Cal., a distance of 140 miles, in the winter of 1909. Locomotive 1,700, a Mallet compound (2-8-8-2), fitted with a Jacobs-Shupert firebox, Buck-Jacobs superheater, and feed-water heater, cylinders 26 in. and 38 in. by 34 in., had a tractive effort of 108,000 lb. Locomotive 1,962 was of the simple consolidation (2-8-0) type, fitted with Baldwin superheater, cylinders 24 in. by 32 in., and had a tractive effort of 49,500 lb. These curves are presented because they show the enormous back pressure horsepower loss which is an inherent defect in the Mallet type locomotive. The curves show that the maximum power of the Mallet was developed at a speed of approximately 17 miles an hour and that drawbar horsepower and back pressure horsepower equalized at a speed of approximately 25 miles per hour, showing that at this speed the locomotive exerted 950 drawbar horsepower and that an equal power was required to draft the boiler. The curves for the consolidation type show that the maximum power of the locomotive was developed over a wide range of speeds and that back pressure horsepower was not appreciable except at high speed.

The data accumulated from a great many tests conducted over the various divisions of the Santa Fe system, have shown the desirability for some other method of furnishing draft for locomotives to supplant that now commonly used.

*Reported in the *American Engineer*, June, 1912, page 300.

These tests have forcibly demonstrated the inefficiency of the present arrangement when viewed from a thermodynamic standpoint. The chief advantage in favor of the present arrangement is that it is very efficient, speaking from a purely mechanical standpoint; that is, it is free from any complicated parts which are liable to get out of adjustment and does its work when once it has been set up with very little attention other than minor adjustments to keep it in good working order. It is this feature alone that has enabled the present front end arrangement to exist to the present day. In view of existing conditions, attention was attracted to the possibility of drafting a locomotive by some method of forced or induced draft, but because of the impracticability of installing a system of forced draft on a locomotive, except pos-

The problem, however, was not as simple as it at first appeared. Although there were many existing installations of induced draft, and several manufacturers making a specialty of these installations, yet they were not readily adaptable to the locomotive. In power plant and marine service the space occupied by the draft apparatus is not as important an item as with the locomotive. When the problem of furnishing draft apparatus of this character was presented to the manufacturers, they were able to calculate the size of the fan and the horsepower necessary to drive it to burn the required amount of coal per hour, but when the space that such an apparatus would occupy was taken into consideration, they were astounded, and were not able to furnish either data or apparatus satisfactorily to meet the requirements. For this

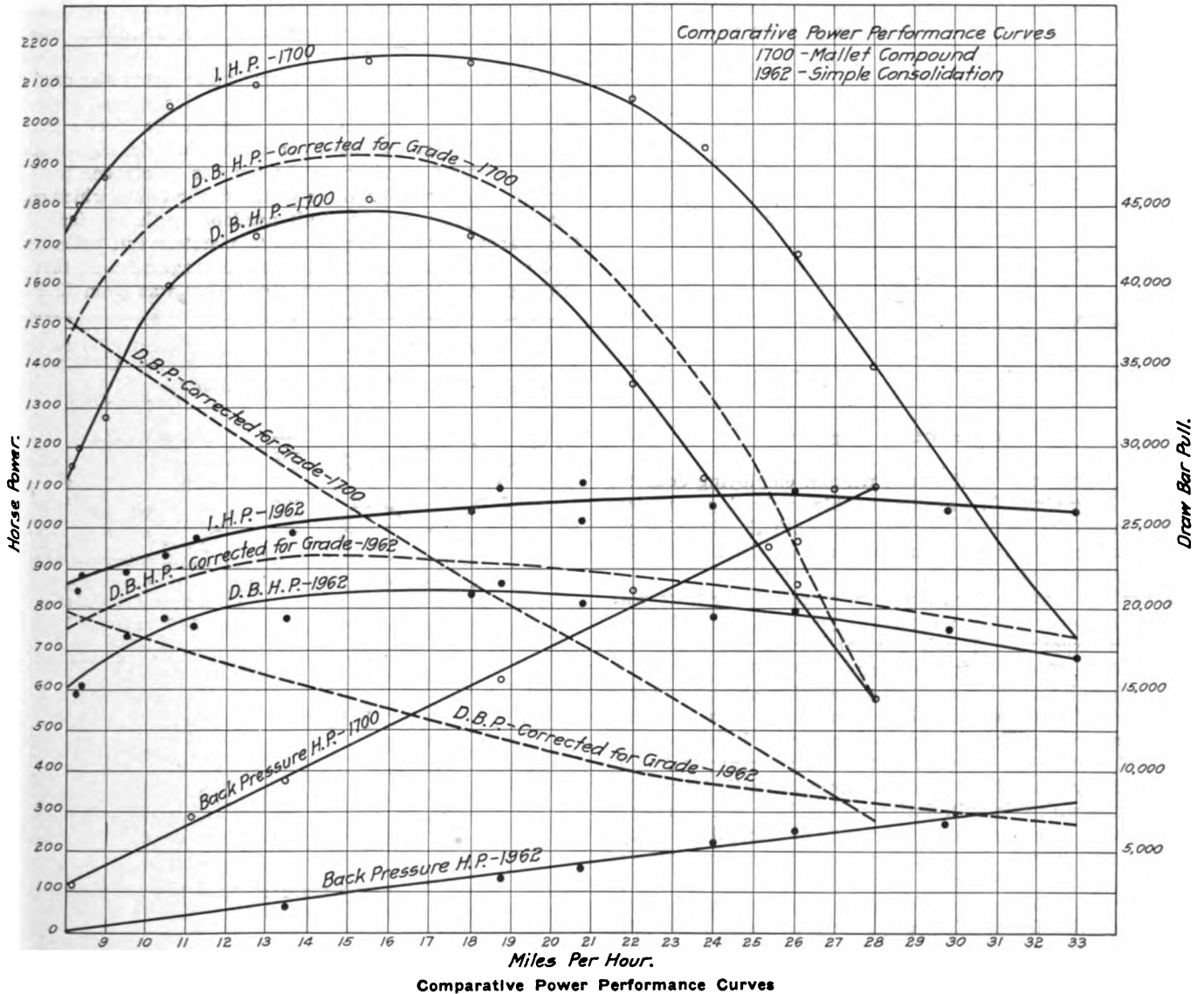

sibly in the case of stoker-fired locomotives where it is not necessary to open the fire door, this form of draft was abandoned and attention directed to the adaptation of induced draft for the purpose. It is a well known fact that induced draft has been successfully applied in stationary and marine service, and its development in these fields has been rapid during the past few years, so that we now have many installations of this character. The development of the steam turbine and progress in the theory and construction of centrifugal fans for this work has added much to the progress made and it seemed logical that if the system could be so successfully applied to other fields, it would find ready application to the locomotive.

reason it was absolutely necessary to start in at the beginning and develop such an apparatus.

The first step in the development was to secure data showing just what could be expected in draft obtainable, in fuel consumption, in boiler efficiency, and in power requirements to operate a fan draft system. Locomotive 932 was secured for experimental purposes and an experimental plant constructed to secure the data. The test was confined to the boiler of the locomotive with a 48-in. ventilating fan attached to the smokebox. No attempt was made at this time to run the engine on the road. Connection was made between the inlet of the fan and the smokebox of the locomotive so that the exhaust was through the fan rather than through the ordinary

stack. The fan was driven by means of a 25-horsepower constant speed motor, belt connected. The variation in speed at which the fan was driven was accomplished by changing the diameter of the pulleys. The power necessary to drive the fan at various speeds was accurately determined by measuring the current necessary to drive the motor. With this arrangement a series of tests were made in Topeka, Kan., in February, 1912. A maximum of 3,350 lb. of coal was burned per hour, and a maximum of 830 boiler horsepower was developed. This was accomplished at an expenditure of 20 horsepower required to drive the 48 in. fan at an average speed of 715 revolutions per minute; the maximum draft in the smokebox was $2\frac{7}{8}$ in. of water. The first tests in the series were made with the diaphragm in place in the smokebox, but this was removed during the later runs and it was found that with the fan draft it was possible to get a very

under the various conditions show the possibilities of the fan draft in eliminating the back pressure of the engine. While the fan used during the later series of tests was not mechanically correct or of sufficient capacity to develop the maximum power of the locomotive, it was of sufficient capacity to bring out many valuable points relative to the general performance to be expected from a system of this kind. The locomotive burned its fire as satisfactorily with the fan draft arrangement as with the standard front end arrangement, and there was no more tendency for the fire to bank or clinker. A uniform draft varying from 4 in. to $6\frac{1}{4}$ in. of water was maintained with the fan draft.

The capacity of the fan was limited to the maximum safe speed at which it could be run, and when the demand upon the boiler was such that it could be supplied with the draft available within the maximum speed of the fan, there was an economy shown. This was evident when the locomotive was working on grades, where, although more steam was used per stroke, the relatively low speed of the locomotive made the total steam consumption lower than on the level stretches where less steam was used per stroke, but the higher speed and consequent increase in the number of strokes per unit of time, placed a demand for steam on the boiler which could not be supplied by the draft available with the fan. For this reason, it was not possible to maintain full boiler pressure at all times with the fan draft arrangement, so that the initial pressure available in the cylinders was from 12 lb. to

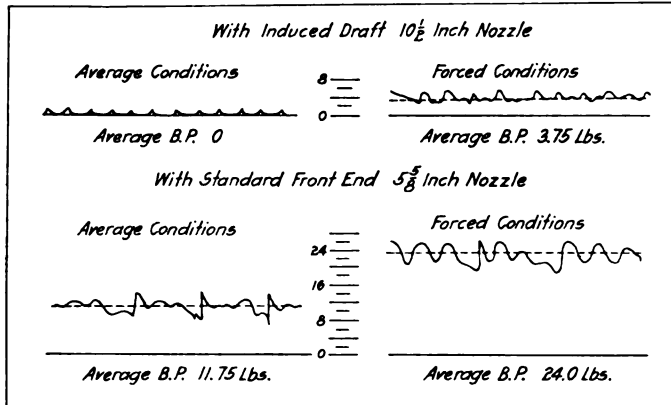

Exhaust Cavity Diagrams

uniform distribution of the draft without employing deflector plates of any kind. It was not possible to develop anywhere near the maximum boiler horsepower with this installation, but valuable data were secured for use in the construction of an experimental unit for drafting purposes.

From the data obtained from these preliminary tests with the 48 in. fan applied to both coal and oil burning locomotives, an experimental unit adaptable to locomotives was furnished by the manufacturers and delivered to Topeka in September, 1912. This unit consisted of a stock 24-in. fan with special provision for direct connection to a 40 horsepower steam turbine, the entire apparatus being so constructed as to be a compact unit suitable for application in the ordinary smokebox of a locomotive. Preliminary tests were made with this unit, during which the volume of air at atmospheric pressure and temperature, discharged at various turbine speeds, was determined when the fan was operated against various resistances simulating locomotive service. These tests indicated that the fan was of sufficient size for the locomotive for which it was ordered, so that application of the apparatus was made to locomotive 1,302 at Topeka shops in January, 1913. The first actual test of the apparatus installed on this locomotive was made on January 12, 1913. It was soon apparent that the 24-in. fan did not have the capacity to furnish the necessary draft, and it was not until after a great deal of experimental work, during which it was necessary to design and build three fan rotors and make modifications of the fan casing, that a fan of sufficient capacity was secured to permit of actual road tests. During the development of these fans, however, several stationary and road tests were made with the locomotive, during which valuable data were secured.

Prior to tests with the fan draft apparatus, complete tests of the locomotive with the standard front end arrangement had been made for a basis of comparison of results obtained with the two arrangements. Typical indicator cards secured

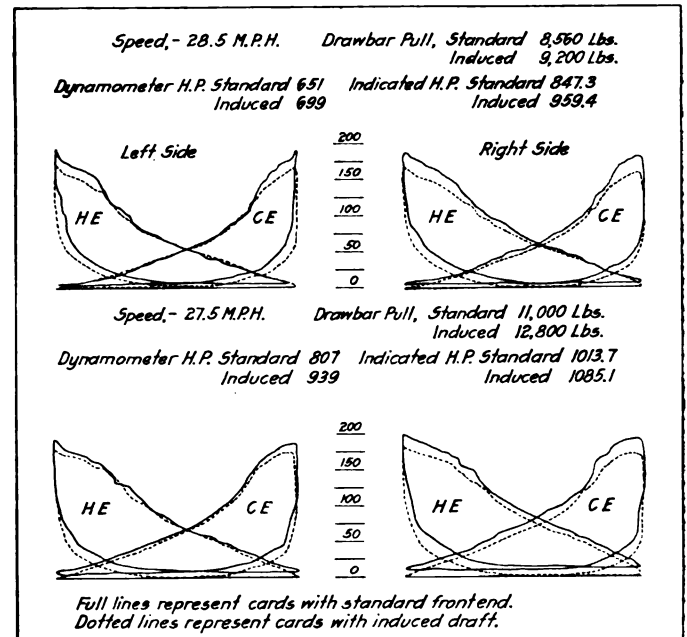

Indicator Cards Taken with Standard Front End and with Induced Draft

13 lb. lower from runs with the fan draft than runs with the standard front end arrangement. Analyses of the indicator cards show that although there was a gain in power as indicated by an increased area at the bottom of the cards, there was a corresponding decrease at the top of the card. This was due to the difference in initial pressure, so that the gain in power due to the elimination of the back pressure was just about sufficient to operate the fan draft apparatus, and there was no apparent gain in the over-all efficiency of the locomotive. This is demonstrated by the indicator cards shown.

A comparison of the performance of the locomotive under the two systems of drafting during periods in the runs when such comparison is at all possible, that is, when working conditions are similar, is favorable to the induced draft arrangement. Such a comparison based upon the actual power de-

livered at the drawbar shows a saving of nearly 20 per cent in fuel for the fan draft, and it is entirely possible to effect a marked saving in indicated horsepower with it.

Typical exhaust cavity cards are shown in one of the engravings. These pressure readings were taken in the exhaust cavity of the valves by means of an independent indicator fitted with a 20-lb. spring. They were chosen to cover the entire field as nearly as possible.

The conclusions drawn from these comparative tests were that it is entirely possible to draft a locomotive boiler by means of an induced draft fan to replace the exhaust tip commonly used; that it is possible to entirely eliminate the cylinder back pressure under normal conditions and greatly reduce it under forced conditions of operation of the locomotive; that with equal steam chest pressures, cut-offs, and speeds there is an appreciable increase in indicated horsepower due to the elimination of the cylinder back pressure, and that it is entirely possible to successfully operate an installation of this character at the necessary high speed during

provision of both maximum speed and pressure governors and an arrangement which insures the starting of the turbine at the time the main locomotive throttle is opened, and shutting off when the throttle is closed. In addition to these features, an independent steam line is provided which makes possible the operation of the turbine at nearly its maximum speed when the locomotive is standing.

The maximum speed governor is made a part of the steam turbine itself and is designed to automatically throttle the supply of steam into the turbine when the pre-determined maximum safe speed has been reached. The maximum pressure governor is fitted into the steam line supplying the turbine and is so constructed that the flow into the turbine is automatically throttled when the locomotive boiler pressure has reached within a few pounds of the normal working pressure. This governor is also fitted with an attachment which makes possible the control of steam through the valve from the locomotive cab.

LOCOMOTIVE FRONT ENDS AND DRAFT APPLIANCES

C. D. Young, Engineer of Tests, Pennsylvania Railroad.—There has been a tendency of late to use exhaust nozzles having other than circular openings. The plain circular nozzle forms a steam jet which is too nearly cylindrical, or the shape of the stack, and the use of such a shape as the rectangular appears to break up the continuity or the form of the jet and cause it to draw out a larger volume of gases. Both rectangular nozzles and nozzles of the dumb-bell shape have been used with success, and with an increase in evaporation over that with the circular form. There has recently been developed on our locomotive testing plant a nozzle having four internal projections which appears to be more satisfactory than some of the irregularly formed nozzles. With these nozzles, having other than a circular outlet, an increase in the evaporative capacity of the boiler of from 15 to 25 per cent has been obtained and in recent tests on a large Pacific type locomotive a nozzle with four internal projections has given a maximum capacity in equivalent evaporation from and at 212 deg. of 87,414 lb. per hour. In the locomotive in question, this is an evaporation of 18.0 lb. of water per square foot of heating surface per hour and with this quantity of steam an indicated horsepower of 3,184 was obtained; whereas, the circular nozzle on this same locomotive developed a maximum equivalent evaporation of but 62,719 lb. of water per hour, resulting in an indicated horsepower of 2,501. It should be understood that no change was made in the locomotive other than in the exhaust tip.

It has been the practice on the Pennsylvania to require that the air openings into the ashpan be at least 15 per cent of the area of the grate, and when the openings are of this size, the ashpan vacuum will be considerably less than one inch of water at the maximum evaporative rates. We have found, however, in the case of some switching locomotives, that this area of 15 per cent of the grate area has been too large for the requirements of their service and to provide for this condition upon shifting locomotives, ashpan dampers have been installed along the air inlets at the mud ring. This arrangement very nicely takes care of these locomotives, which stand a great deal of the time, and if the air inlets in the ashpan were not reduced, it would be difficult for the firemen to prevent a large amount of steam from escaping from the safety valves.

C. E. Chambers, Superintendent of Motive Power, Central Railroad of New Jersey.—Two or three years ago we had a new type of locomotive which gave us some trouble. After a number of trials of various expedients it occurred to me that the stack might be too small, so I took up with the locomotive builders the question of the relation of the diameter of the stack to the diameter of the cylinder, and it was admitted by them that the stack was smaller than it should be. We increased the diameter from 15 in. to 18 in. at the choke. We had perhaps one hundred or more engines with the same size stack, and about the same

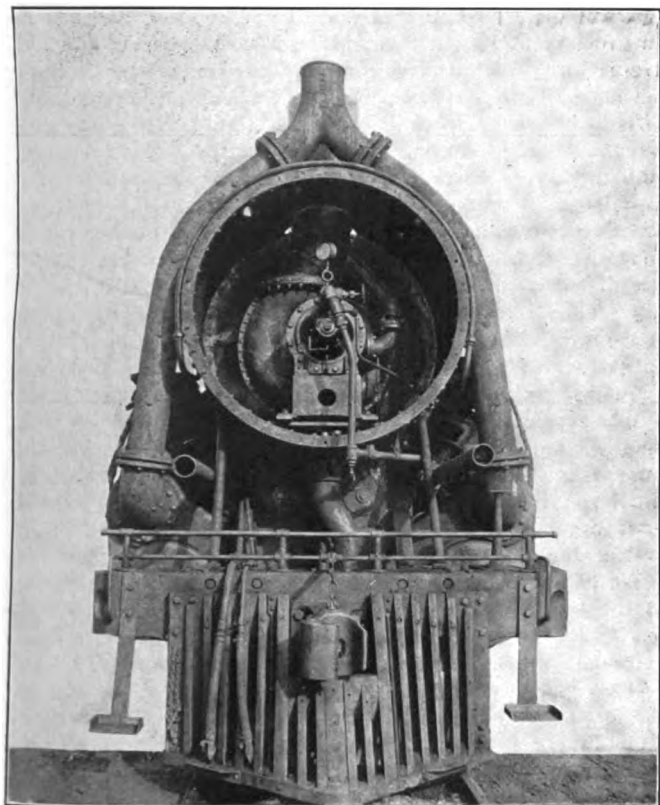

Arrangement of the MacFarland Fan Draft

intervals of time representing a run over the average division of a railroad.

The logical field for locomotive mechanical draft is upon compounds in general and Mallet compounds in particular, where the excessive back pressure results in more pronounced cylinder losses. The development of this branch of locomotive engineering will necessarily be gradual, on account of the absence of data or lack of experience on the subject.

The experience with the fan draft gained from actual tests led to the development of an automatic control system to govern or regulate the speed of the turbine, and consequently regulate the intensity of the draft. It was found that it was highly desirable to make the operation of the fan as nearly automatic as possible and not have to depend on the engineer or fireman to regulate its action. At the same time, its operation should be under the control of the fireman at all times should he choose to exercise control. The essential features of the automatic control system which have been developed are the

cylinder volume, but not in the same kind of service, so that they did not give us much trouble. But after making these changes on this particular type we made the change on the other engines and found a decreased consumption of coal.

One small improvement we have made in smokebox fronts where there is trouble from overheating is the placing of a liner about 4 or 5 in. away from the smokebox door, and filling the space with asbestos. This entirely eliminated the overheating.

COMBUSTION IN LOCOMOTIVE FIREBOXES

J. P. Neff, vice-president American Arch Company.—All modern locomotives, or at least practically all those built in the last few years, have been built to haul heavy steel passenger trains on hard schedules or to meet exacting conditions in other kinds of service. As the locomotive itself has been greatly improved and refined in the last ten years, so has this special device, to the end that it has been shorn of many of its original faults, leaving its never disputed virtues standing out all the more prominently. The brick arch insures more nearly complete combustion. The combustion of high volatile coal at the rapid rates necessary to meet the demands for large hauling capacity today is fraught with considerable losses due to incompleteness. That represented by the CO content in front end gases is only a part of it. The losses from the incomplete combustion of hydro-carbons may easily be four times that represented by the CO per cent in the gas analysis. Anything that will mitigate these losses without introducing too high air excess reflects at once in higher furnace temperatures. The introduction of the combustion chamber helps by lengthening the flame travel, but the introduction of the arch, especially the arch on water tubes, not only doubles the average length of the flame travel, but possesses the more important virtue of being a mechanical mixer.

By fostering or enhancing combustion above the fuel bed in this way considerably more heat is evolved and higher firebox temperatures result. Authentic tests have shown that with certain coals this increase in firebox temperature may be 15 per cent; yet, as a rule, these higher firebox temperatures are not accompanied by higher front end temperatures. This is explained by the fact that the tube supported arch by virtue of its position performs another important function, that of forcing these higher temperature gases to sweep or brush at considerably increased velocity a considerably greater area of evaporating surface; not only the added area of the arch tube surface, but much surface of hitherto unswept firebox plate, so that the double result is accomplished, of creating more heat, and causing to be absorbed this increased amount of heat, giving a net result of increased boiler output for the same amount of coal consumed, a distinct advance or rise in the boiler efficiency.

The circulating tubes or arch pipes play no small part in this. Not only do they present by far the most effective heat-transmitting surface, but the circulating effect in itself is very important, especially at high rates of evaporation. Just as the particles of gases must quickly touch the heat absorbing surface and give way instantly to other particles, so must the water, or steam film, on the opposite side of these surfaces give way quickly to other particles of water, if a high rate of heat transfer is to be accomplished. Expedited circulation will insure this favorable condition. A locomotive boiler can no more give high duty per pound of weight or square foot of heating surface when the gases move leisurely over its surfaces and through its tubes than can the locomotive as a whole give high horsepower in a slow turning of the wheels.

J. T. Anthony, Manager Service Department, American Arch Company.—High firebox evaporation means high boiler efficiency, for the high heat absorption by the firebox reduces the temperature of the gases entering the tubes; and for any one boiler, the temperatures of the gases entering and leaving the tubes are directly proportional when reckoned above steam temperature. Hence a lower temperature of entering gases means lower front end temperatures and an increase in efficiency.

A large percentage of the bituminous coal burns above the grate as gas. The rapidity and completeness of the combustion of these gases depends on the amount of oxygen present and the thoroughness of the mixing. In a firebox with 60 sq. ft. of grate, with a rate of combustion of 60 lb. of coal per square foot of grate per hour, an air supply of 20 lb. per pound of coal and an average firebox temperature of 2,000 deg., the volume of the gases evolved is about 1,200 cu. ft. per second. A firebox of this size would have a capacity of about 200 cu. ft., and would have to discharge and be refilled with gases about six times per second. The average time available for combustion of each particle of gas would then be about one-sixth of a second, and this is insufficient for complete and proper mixing by diffusion. With the short time allowed, it is necessary to mix the gases by mechanical means, and this is generally accomplished by an arch or baffle which forces the gases to pass through a restricted area, this area being not less than the net tube area.

It is evident that mere firebox volume is not sufficient of itself, and it is necessary to have a flamework of such cross section and length as to intimately mix the gases and provide sufficient space for burning before the gases reach the tubes. In an ordinary firebox, without baffle or combustion chamber, the average length of flamework is only 5 to 6 ft. By the introduction of baffles and combustion chambers, this length can be increased to from 10 to 15 ft., which results in not only more complete combustion but also in increased radiating surface, with a corresponding increase in firebox evaporation and a lowering in temperature of the escaping gases.

A Pacific type locomotive with 55 sq. ft. of grate area, a tube-supported arch and an average flamework of 8 ft. had an average firebox temperature, covering a range of 25 tests, of 2,100 deg. This temperature was taken at the center of the firebox at about the end of the arch. The gases entering the tubes showed an average of 1,725 deg., or a drop in temperature of 375 deg.

Another Pacific type locomotive with the same size grate and a tube-supported arch, but with a combustion chamber 3 ft. long, giving an average flamework of 11 ft., showed over the same range of tests an average firebox temperature of 2,185 deg., with the temperature of the gases entering the tubes of 1,485 deg., or a drop of 700 deg. between the center of the firebox and the tube sheet.

We obtain high efficiency at low rates of combustion in spite of the large air excess which generally accompanies. This is due to the fact that at low rates the firebox absorbs a larger percentage of the total heat evolved, and the amount so received for any one firebox depends primarily on the temperature of the fuel bed. It is possible that this temperature is higher with large air excess than with the lower, as the temperature is due to the rapidity of combustion which in turn depends upon the scouring and cutting action of the air blast.

The firing clearance, or the vertical distance between the fuel bed and the lower tubes, or arch, has been materially increased by the introduction of modern types of locomotives with trailing trucks, as this has permitted the firebox to be placed behind the drivers and the grates dropped lower. This one step has probably offset to some extent the high ratios between heating surface and grate area which are found in modern locomotives. The extent of the firebox heating surface is determined largely by the size and location of the grate; but there is no fixed relation between heating surface and grate area, or between firebox and boiler heating surface.

As stated above, the firebox evaporation depends primarily upon the extent and temperature of the radiating surfaces and not on the extent of the firebox heating surface. Increasing the firebox heating surface without increasing the grate area or flamework will result in very little increase in evaporation. Its only effect is to reduce the amount of heat absorbed by each unit of surface, with a slight reduction in the temperature on the fire side of the surface. An evaporation of 60 lb. of water per square foot of firebox heating surface per hour requires a

difference of less than 100 deg. between the water and the fire side of the sheet, and if sufficiently high firebox temperatures or sufficiently large radiating surfaces could be obtained, it would be possible to materially increase even this high rate of evaporation without forcing the heating surface to its capacity.

In the Coatesville tests, conducted by Dr. Goss, the two fire-boxes gave an evaporation as high as 58 lb. of water per square foot of heating surface per hour; but there was practically no difference in the total amount of water evaporated by each of the fireboxes when working at the same rate of combustion and with the same grate area, notwithstanding the fact that one of them had 12 per cent more heating surface than the other.

Judging from the past, we are not apt to see any radical departures from the present type of firebox in the near future, unless the nature of the fuel is materially changed, and the writer believes that any improvement in the efficiency of this part of the locomotive will be obtained by providing for ample grate area, firing clearance, gas mixing, flamework or combustion chamber space, and air supply.

WHAT THE STOKER HAS DONE FOR THE LOCOMOTIVE

C. F. Street, Vice-President, Locomotive Stoker Company.—The most important accomplishments of the mechanical stoker as applied to locomotives, are the increasing of the earning power of existing locomotives, and the removal of all limitations, from a fuel quantity standpoint, on the size of locomotives.

The locomotive designer should always keep in mind the fact that every dollar earned in the operation of a railway must be earned by its locomotives, and, therefore, I have, in the above, given first place to the increase in the earning power of existing locomotives. I could cite many instances to prove this statement, but as an illustration, will take one:

A locomotive having about 54,000 lb. tractive effort when running with saturated steam, had a tonnage rating over a certain division of 4,750 tons. Superheaters were applied to this locomotive, and the tonnage increased to 5,000; stokers were applied, and the tonnage increased to 5,250; then 5,500; then 5,750, and finally 6,000 tons. In the meantime, the tonnage rating of the shovel-fired, superheated steam locomotives was increased to 5,500 tons. This shows an increase of over 20 per cent in the tonnage rating of this locomotive after the stokers were applied, and the locomotive today, stoker-fired, is hauling 10 per cent more tonnage than when shovel-fired.

The increase in the tonnage rating of the shovel-fired locomotives is very interesting, and brings out strongly one of the indirect advantages of the stoker. Before stokers were applied, the shovel-fired locomotives were not doing anywhere near what they should do, and as soon as the stoker came into use, it increased the earning power, not only of locomotives to which it was applied, but of all others on the division.

The stoker is making it possible to come much nearer to theoretical conditions in regular operation. We all know that there is a wide difference between the earning power of a locomotive under test conditions and under average road conditions. I have in mind one case, in which, under test conditions, it was found that a certain locomotive could haul 4,000 tons comfortably over a certain division. When put in regular service, how-

ever, it was found impossible to operate it with more than 3,500 tons over this same division. With the stoker, these locomotives can easily haul 4,000 tons in regular road service.

The fact that the stoker has removed limitations in the size of locomotives can be brought out by reference to several of the locomotives referred to in the committee's report. The Mountain type locomotives referred to were fitted with stokers when they were built, have always been stoker-fired, and no attempt has ever been made to shovel-fire them. One of the locomotives referred to would never have been built had it not been known that a stoker could be secured which would fire it. There are 30 of the locomotives of one class referred to now in regular operation, and they would never have been built had it not been known that a stoker could be secured which would fire them. A number of other locomotives, notably the most powerful Pacific type as yet built, are now in regular operation, and would never have been contemplated without a stoker.

There are today, very few, if any, shovel-fired locomotives in this country having a maximum tractive effort of 50,000 lb. or over, which are being worked to their full capacity. Wherever stokers have been applied, the earning power of the locomotives on which they have been placed has been increased from 10 to 20 per cent. There is no instance where stoker-fired and shovel-fired locomotives are being operated under identical conditions. The stoker-fired locomotives are hauling increased tonnage, using a cheaper fuel, or working at higher average speeds than the shovel-fired locomotives, and are, therefore, earning more money.

E. A. Averill, Engineer of Operation, Standard Stoker Company.—Although the proper firing of a locomotive by hand has reached the stage of a skilled operation and some remarkable records have been made in certain instances, the progress of locomotive development has now almost entirely passed the point where skilled manual firing can properly do the work if the full capacity of the locomotive is to be used.

At a speed in miles an hour equal to about one-half (.476 to .636) the diameter of the drivers in inches, the capacity of most modern freight locomotives is fixed by the boiler capacity. In a report of a test on a large locomotive at the Altoona test plant of the Pennsylvania Railroad, it is stated that the results indicate that the capacity of the boiler was limited by the ability to burn the coal on the grates and not by any failure of the heating surface to absorb the heat supplied. While in this case the limit was marked by the impossibility of supplying sufficient air through the grates to properly burn the fuel, there are a reasonably large number of locomotives operating in this country today which are running at less than full boiler capacity because of the physical inability of the fireman to supply the amount of fuel that can be burned. These locomotives are giving to the drawbar the pull which the man can supply but not what the locomotive is capable of supplying at the desired speed.

I have selected at random ten classes of locomotives built during the past three years which are typical of the general size and capacity of all the larger freight engines built in that time. These are shown in the accompanying table. The American Locomotive Company's standard practice in connection with steam per horsepower hour and evaporation per pound of coal has been used; also the percentage of tractive effort and maxi-

Type	Cylinders, In.	Steam Pres., Lb.	Diam. Driv., In.	Max. Tractive Effort, Lb.	Max. Cyl. Hp.*	Normal Hp. from Heating Surface	Coal per Hr. at Max. Hp.†	Speed for Max. Hp.‡	On grade of .05 per cent					
									Speed m.p.h.	Tons in Train	Hp. Req'd	Coal per hr., Lb.	Coal at G. A., Lb.	Water per sq. ft., Lb. H. S.,
2-2-2	25 x 32	180	63	48,600	2,027	2,210	6,587	35	25	1,930	1,945	6,320	112	9.88
2-2-2	28 x 32	170	63	57,460	2,400	2,310	7,507	35	25	2,382	2,290	7,440	106	11.5
2-2-2	27 x 30	175	63	51,700	2,296	2,269	7,374	37.5	25	2,183	2,160	7,020	100	11.05
0-8-0	26 & 41 x 28	200	51	105,000	3,032	8,759‡	32.5	15	6,050	2,860	8,240‡	82.4	10.6
4-2-2	28 x 28	185	69	50,000	2,613	2,451	7,965	44	35	1,403**	2,390	7,767	124	12
2-6-2	21 1/2 x 34 x 32	200	57	67,500	2,533	2,312	7,514	32	15	3,820	1,940	6,300	111	9.2
2-2-2	28 x 32	180	64	60,000	2,542	2,418	7,858.5	36	25	2,470	2,410	7,840	100	10.8
2-2-0	26 x 30	185	57	55,900	2,251	2,167	7,242	34	15	3,210	1,765	5,750	86	10.4
2-2-2	26 & 40 x 30	200	57	87,600	2,942	9,561	34	15	5,060	2,390	7,800	92	9.2
2-2-0	25 x 30	180	57	50,328	2,027	1,848	6,006	34	15	2,920	1,510	4,900	87	11

*Horsepower + .01798 Pd² at 1,000 ft. piston speed. †Normal horsepower from heating surface = evaporation, lb. per hour ÷ 20.8 lb. ‡ 3.25 lb. coal per horsepower hour. § 7.2 lb. water per lb. of coal. ** Passenger train.

mum horsepower at various piston speeds and the evaporation per square foot of heating surface for the firebox and tubes. It is assumed that each locomotive is working at the speed indicated on a .5 per cent grade, and that the cars in the train each weighs with lading 70 tons.

When delivering the power each of these locomotives is easily capable of giving, if in good condition, it will be seen that they require from 4,900 lb. to over 8,000 lb. of good quality coal an hour. Similar calculations for grades of less rise will show a higher speed and greater coal requirements per hour.

It is evident that these engines, with the possible exception of the last one, are not being supplied with this amount of coal, although they could use it if they were. They are actually getting from 4,500 to 5,000 lb. an hour and handling trains of a proportional size. The last one on the list is included to show the size that lies near the dividing line between hand and stoker-firing. These ten examples are typical of the ones referred to as giving the drawbar pull the man can supply, but not what the locomotive is capable of supplying.

A number of locomotives like these, all of the same class and operating on the same division, will have a tonnage rating in proportion to the ability of the average poorest fireman that is assigned to them rather than of the average best fireman. While there may be a few firemen on the division who are capable of developing the full boiler capacity, the group of engines as a whole may be daily working much below their actual capacity. The acceptance of the opportunity to supply the desired quantity of coal at all times to these locomotives, that is offered by the stoker, will have the same practical effect on operating expense as would a new order of more efficient, larger locomotives. A reduction in the cost of conducting transportation follows this increased locomotive capacity in a number of the principal items when presented on a ton-mile basis. The stoker itself offers an opportunity for further saving, particularly in the cost of fuel, reduced claims for damage or accident, and the recruiting of men of higher caliber for locomotive service.

An instance of the possible savings in the cost of conducting transportation through increased locomotive capacity following the application of a stoker, is found on a certain division where ten tonnage trains are sent one way over the road each day with hand-fired locomotives. Application of stokers has permitted an increase of over 11 per cent in the tonnage of a train. The return movement is largely empties. The application of stokers will give a direct saving in wages and train supplies alone of about \$100 per engine a month on this division. If advantage is taken of the increased capacity of the division for tonnage without adding locomotives, the saving will be larger.

FEED WATER HEATING

H. H. Vaughan, assistant to vice-president, Canadian Pacific, stated that considerable has already been heard as to the experiments made on feed water heating by Mr. Trevithic on the Egyptian railways, in which he used not only exhaust steam heaters, but waste-gas heaters in the front end. With the latter he has been able to put the water into the boiler at 230 deg. and obtain 22 per cent economy. In this country the Central Railroad of Georgia has done a little with feed water heaters, as well as the New York Central, the Canadian Pacific, and the Central Railroad of New Jersey.

"On the Canadian Pacific we have been experimenting with feed water heating for six years. We have tried open heaters in a tank with fairly good satisfaction. We also applied exhaust steam injectors, and got fair results. We have since been advised by the manufacturers that our troubles were because of our having applied an injector of too large size for ordinary work on the engine. However, I am of the opinion that while the exhaust steam injectors would work fairly well under certain conditions, yet there would be some difficulties where the amount of water consumed is large. We found on experiments with an open heater that the temperature obtained was due to the exhaust

steam from the feed pump, so, assuming a temperature of 200 deg. in the feed water, it would really be the equivalent of 160 deg. when the water was put into the boiler by an injector with 100 per cent efficiency. By heating the water at the injector suction to 120 deg., we got 6 per cent economy, and used injectors as against 10 or 12 per cent economy with the feed water heater, and using a pump. We thought 6 or 7 per cent with the injector was preferable to 10 or 12 per cent with the pump, and we have been experimenting on that in recent years with reasonable results. Lately we have experimented with an ordinary closed feed water heater, and it is giving fair results.

"This is a subject which American railroad people have largely neglected. It has the advantage of not only saving in coal, but increasing the capacity of the boiler. In careful experiments we found an economy of 12 per cent in the use of the heater, and we feel that that justifies our going into the device more thoroughly. I feel that we will see feed water heating coming into larger use, not only with exhaust steam, but with waste gas."

F. F. Gaines, superintendent of motive power, Central of Georgia, said in part: Feed water heating in this country is confined to a limited number of cases, and cannot be said to be generally recognized as a factor in fuel economy. Experiments made on several engines show that about 10 per cent economy can be expected; there have been, however, offsetting difficulties in maintenance.

The feed water heater in question was made up of two elements. The first consisted of a pair of condensers in the form of long drums applied underneath the running boards. The steam from air pumps, boiler feed pumps, and some of the main exhaust was condensed in them and the heat taken up by the feed water. The second element consisted essentially of a double nest of tubes in the smokebox, similar to a Baldwin type superheater. The feed water from the tank was forced through the condensers and smokebox heater, and from the heater through the regular boiler checks.

Some trouble was experienced with operation of the pump, and it was also found that the type of pump used was not altogether suitable for the purpose, wearing very rapidly and having considerable slippage. The smokebox heater tubes were objectionable from the standpoint of obstructing draft and filling up with soot and cinders between the tubes, also cutting out very rapidly by the action of the exhaust. There was a further objection due to the fact that the condensed steam from the air pumps and boiler pump exhaust was still at a temperature that, in cold weather, would give off considerable clouds of steam, and as this water had to be wasted, the result was a cloud of steam around the engine, which was objectionable because of obscuring the view of the engineer in looking back over the train.

These heaters were used some two or three years, however, and tests were made which showed them to have a fuel economy somewhere in the neighborhood of 10 per cent.

LOCOMOTIVE SUPERHEATERS

Geo. L. Bourne, Vice-President Locomotive Superheater Company.—The locomotive boiler, when considered for the application of a superheater, presented many limitations that necessarily have an important bearing on the design and construction of the superheater. These limitations are more readily appreciated when it is remembered that the development of the locomotive, within certain fixed side and overhead clearances, has been dependent on the size of the boiler; that is, as the size of the locomotive has grown, each pair of wheels has been added to obtain proper weight distribution in order to accommodate increased boiler sizes. As a natural consequence of these conditions, the boiler is no larger than is absolutely necessary; in fact, in the majority of cases it is insufficient in evaporating surface.

The application of the superheater to this boiler, frequently

inadequate as to heating surface, necessitates a reduction of about 15 or 20 per cent in the tube heating surface. This is occasioned by the use of the large flues in which the superheater units are located. Furthermore, a certain percentage of the gases which formerly were all available for evaporation

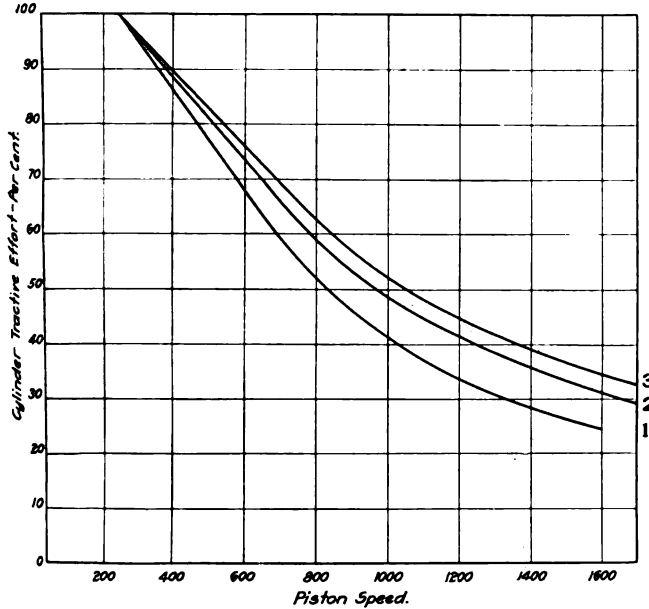

Curves Showing Possibilities of Increased Capacity from Superheating

of the water must now be used for superheating the steam, since the superheater does not provide for any increase in the maximum rate of combustion. Taking this boiler with its deficiencies, the superheater designer has been able to produce an economy of 25 per cent in fuel, as a direct result of saving one-third of the total water evaporated per unit of power developed. This has resulted in greater locomotive capacity.

As an illustration of this fact, the accompanying diagram is presented. It shows cylinder tractive effort in per cent plotted against piston speed. The lowest curve, No. 1, very fairly represents the speed factor for an average saturated steam

locomotive. Curve No. 2 similarly represents the average modern superheated steam locomotive, using between 200 and 250 deg. of superheat. The greater tractive effort available is due to the fact that a longer cut-off is possible with the superheater engine at comparative speeds. The limiting factor at the usual speeds is the ability of the boiler to furnish steam.

These results have been accomplished in the face of boiler limitations, parts of the locomotive not adaptable to the use of highly superheated steam, and lack of experience in the organization which must handle the locomotive. The problems incident to these conditions are rapidly being worked out, and results shown by the superheated steam curve will soon be as basic as the saturated steam locomotive curve was a few years ago. The future then holds a possibility for further saving by increasing the degree of superheat.

The superheater engineer has only made use, thus far, of the same variety of flue sizes as was used by the locomotive designer for tube sizes. If the superheater designer is permitted the use of a size different from the two present standards, it is possible to obtain in a superheater boiler an evaporating surface practically as great as in the saturated steam boiler. The superheating surface in this case will be a net gain to the heat absorbing surface of the boiler. With a boiler and superheater thus arranged, a greater capacity may reasonably be expected, and a curve approximately that shown as No. 3 may be confidently looked forward to in the near future. For some time past large passenger locomotives have been operated very successfully with steam chest temperatures running between 750 and 800 deg. F. Curve No. 3 is representative of locomotives using this degree of steam chest temperature, which means 350 to 400 deg. of superheat.

HEAT TREATED AND ALLOY STEELS

C. D. Young, Engineer of Tests, Pennsylvania Railroad.—With the ordinary annealed carbon steel as used generally for locomotive forgings, such as axles, crank pins, side rods, etc., the minimum physical properties may be considered to be as follows:

Tensile strength.....	80,000 lb. per sq. in.
Elastic limit.....	½ the tensile strength
Elongation in 2 in.....	.22 per cent
Reduction of area.....	.30 per cent

With properly quenched and tempered carbon steel we may expect an increase in the elastic limit of 30 per cent or more,

Parts	Grade of Material	Working Fiber Stress, Lb. per sq. in., in		Ultimate Tensile Strength	Minimum	
		Tension or Compression	Bending		Elongation in 2, in.	
Main and parallel rods.....	Annealed .45 carbon.....	8,000	10,000	80,000	1,800,000	20 per cent
	Quenched and tempered .52 carbon.....	10,000	14,000	85,000	T. S. 2,000,000	20 per cent
Piston rods.....	Quenched and tempered alloy.....	12,000	18,000	100,000	T. S.	20 per cent
	Annealed .45 carbon.....	9,000	80,000	1,800,000	20 per cent
	Quenched and tempered .52 carbon.....	10,000	85,000	T. S. 2,000,000	20 per cent
					T. S.	
Driving axles.....	Quenched and tempered alloy.....	12,000	100,000	20 per cent
	Annealed .45 carbon.....	} Combined bending and torsion in starting	18,000	80,000	1,800,000	20 per cent
	Quenched and tempered .52 carbon.....		20,000	85,000	T. S. 2,000,000	20 per cent
Quenched and tempered alloy.....	25,000		100,000	T. S.		
Crank pins.....	Annealed .45 carbon.....	13,500	80,000	1,800,000	20 per cent
	Quenched and tempered .52 carbon.....	16,000	85,000	T. S. 2,000,000	20 per cent
Cast steel parts.....	Quenched and tempered alloy.....	20,000	100,000	T. S.	20 per cent
	Annealed .28 carbon.....	8,000 (Tension)	60,000	1,400,000	22 per cent
	Quenched and tempered .28 carbon.....	10,000 (Tension)	75,000	T. S. 1,800,000	20 per cent
Springs.....	Drawn 1.0 carbon.....	70,000	90,000	Bend Test 25 deg.
	Quenched and tempered 1.0 carbon.....	90,000	120,000	25 deg.
	Quenched and tempered alloy.....	100,000	150,000	50 deg.

Note.—Maximum figures for working fiber stress may be 20 per cent in excess of those shown.

about 15 per cent increase in tensile strength, the elongation remaining the same and the reduction of area increasing about 50 per cent. These are conservative figures and a great deal better elastic limit and tensile strength may be obtained, depending upon the chemical composition and the heat treatment.

From alloy steels, such as chrome-vanadium or chrome-nickel, we may expect to obtain the following minimum physical properties after heat treatment:

Tensile strength.....	95,000 lb. per sq. in.
Elastic limit.....	75,000 lb. per sq. in.
Elongation in 2 in.....	20 per cent
Reduction of area.....	30 per cent

On an average these alloy steels will show an increase in physical properties over those of annealed carbon steel of 20 per cent or more in tensile strength, 80 per cent or more in elastic limit, with elongation in 2 in. about 9 or 10 per cent less than that of the carbon steel, and the reduction of area 75 per cent or more greater. These figures are also subject to considerable variation.

In carbon steel castings approximately the same per cent increases in physical properties as were given for carbon steel forgings may be obtained after proper heat treatment. The experience with alloy steel castings has been too limited to furnish any satisfactory data.

Up to the present the majority of users of heat treated steels seem to have made but little, if any, use of the increased physical properties as determining the fiber stresses used in design, though some of the larger builders of locomotives have made such increases in fiber stresses for both heat treated carbon and alloy steels. In certain parts where heat treated carbon steel has been used, the fiber stress has been increased about 25 per cent above that used for annealed carbon steel, and in the case of heat treated alloy steels an increase of as much as 50 per cent has been made. In some cases, depending upon the design and service for which the forging is intended, it is preferable to allow no increase in the fiber stress, but to consider the excess strength as contributing to increased life in service, or to safety.

Recent practice has indicated that it is desirable, when using heat treated designs, to carefully study the sections, so as to avoid abrupt changes, and also in the case of larger shafts, such as axles or crank pins, that they should be hollow bored in order to provide for better treatment and to relieve shrinkage strains which occur during the quenching process.

While there is no objection to the change of the present standard section, it would seem, with our present knowledge of heat treated material, that it would be entirely safe to use certain increases in the fiber stresses when designing the locomotive parts, and, as a suggestion as to what could be done in this respect, the accompanying table shows what is recommended for three grades of steel as to working fiber stresses and the minimum ultimate strength and elongation. This has been tabulated for .45 annealed carbon, quenched and tempered .52 carbon, and quenched and tempered alloy steels.

Results seem to indicate that heat treated carbon and alloy steels will show greater resistance to wear and to the fatigue stresses in service than annealed carbon steel, and it is our opinion that the increase in resistance to wear is about in proportion to the increase in Brinell hardness.

POSSIBILITIES OF THE FUTURE

J. B. Ennis, Chief Mechanical Engineer, American Locomotive Company.—The large steam locomotive of the future will probably not be the locomotive of the past. Today we can see possibilities toward further refinement in design and further economies that may be obtained.

For freight service on easy grades where the capacity of the articulated type is not required, we already have exceptionally large locomotives of the six, eight and ten-coupled types. Simple cylinders operating at 200 lb. pressure have reached a diameter of 30 in., and in order to transmit this

power a main axle 13 in. in diameter has been used. Main crank pins, connecting rods and other details are of enormous size. With the increase in the diameter of cylinders, the cylinder centers have gradually been increasing, and frame centers decreasing. This has resulted in higher stresses than those caused by piston thrust only. The weight of revolving and reciprocating parts has reached the point now where, in some cases, proper counterbalancing becomes very difficult. It is doubtful whether much more capacity can be obtained in these types if designed along the present lines, and attention could profitably be given to refinement in design and its relation to the careful selection of materials.

The modern passenger locomotive has reached a high state of development, but there is one problem still to be solved that has been recognized for many years, that of the effect on the rail of the vertical unbalanced forces in a two-cylinder engine. At present, our largest and most powerful passenger locomotives have two simple cylinders, 27 in. to 29 in. in diameter, giving maximum piston thrusts of approximately 117,000 lb., with static wheel loads higher than ever before and, with few exceptions, reciprocating parts of much greater weight. The four-cylinder balanced compound was introduced about ten years ago as a possible solution, and for a few years large numbers of these locomotives were built. There is no doubt as to the results obtained, as far as balancing is concerned, but recently very few have been constructed. Four-cylinder simple locomotives have also been tried out, but in both of these types the capacity is limited on account of the available space between the frames, making it practically impossible to provide the power now given by the largest simple two-cylinder engines.

Little consideration has been given to the advantages of the three-cylinder arrangement, although a few locomotives of this type are in successful service today. As compared with the four-cylinder engine, either simple or compound, the three-cylinder type offers the possibility of increased power. With one cylinder located between the frames ample room is provided for a properly designed crank axle and main rod which cannot be arranged for in the four-cylinder type beyond a certain limit. As compared with the two-cylinder engine, the advantages are, briefly, a more even turning moment, an ideal counterbalance condition, and the opportunity to furnish maximum power with the minimum destructive effect on the rail. The power obtained in a two-cylinder engine with cylinders 27 in. in diameter and a maximum piston thrust of 117,000 lb. can be obtained in a three-cylinder engine with cylinders 22 in. in diameter and a maximum piston thrust of 78,000 lb. This decrease of 33 per cent in thrust means a corresponding reduction in the individual weights of all of the machinery.

It is true that considerable progress can yet be made in the two-cylinder engine toward reducing the weights of reciprocating parts by the careful selection of materials and proper design. The three-cylinder engine, however, offers advantages possessed by no other arrangement, and it would seem that for high speed passenger service, at least, this type is well worth considering for the future.

G. R. Henderson, Baldwin Locomotive Works.—There is one subject which has not been referred to except by the committee, and that is the question of powdered coal. I think in a few years we will have largely extended its use. Powdered coal will also assist in lengthening the firebox and give a greater amount of evaporative surface in that way. These things must be considered as increasing the length of the locomotive. In increasing the length, fortunately, we can put a heavier engine over the present bridges without having to remodel their construction. By lengthening, I think it is possible to build a locomotive of 250,000 to 300,000 lb. tractive effort.

A STUDY OF SPRING RIGGING DESIGN

Discusses the Probable Causes of Failure and Gives Suggestions for Designs to Overcome Them

BY J. P. SHAMBERGER

A prominent road in the middle west has been having trouble with failures of the spring rigging on large power. The most trouble has been experienced on Mikado locomotives, having a weight on drivers of 238,200 lb., and a weight on the leading and trailing trucks of 29,000 lb. and 52,000 lb., respectively. These

determining the reason why these hangers should fail in this way. Evidence that the hangers do not fail by direct tensile strain was obtained when comparing the stresses in the equalizers and the hangers. The section of one of the intermediate equalizers 8 in. back from the pin hole is 2 in. by 6 in., and it is loaded to a

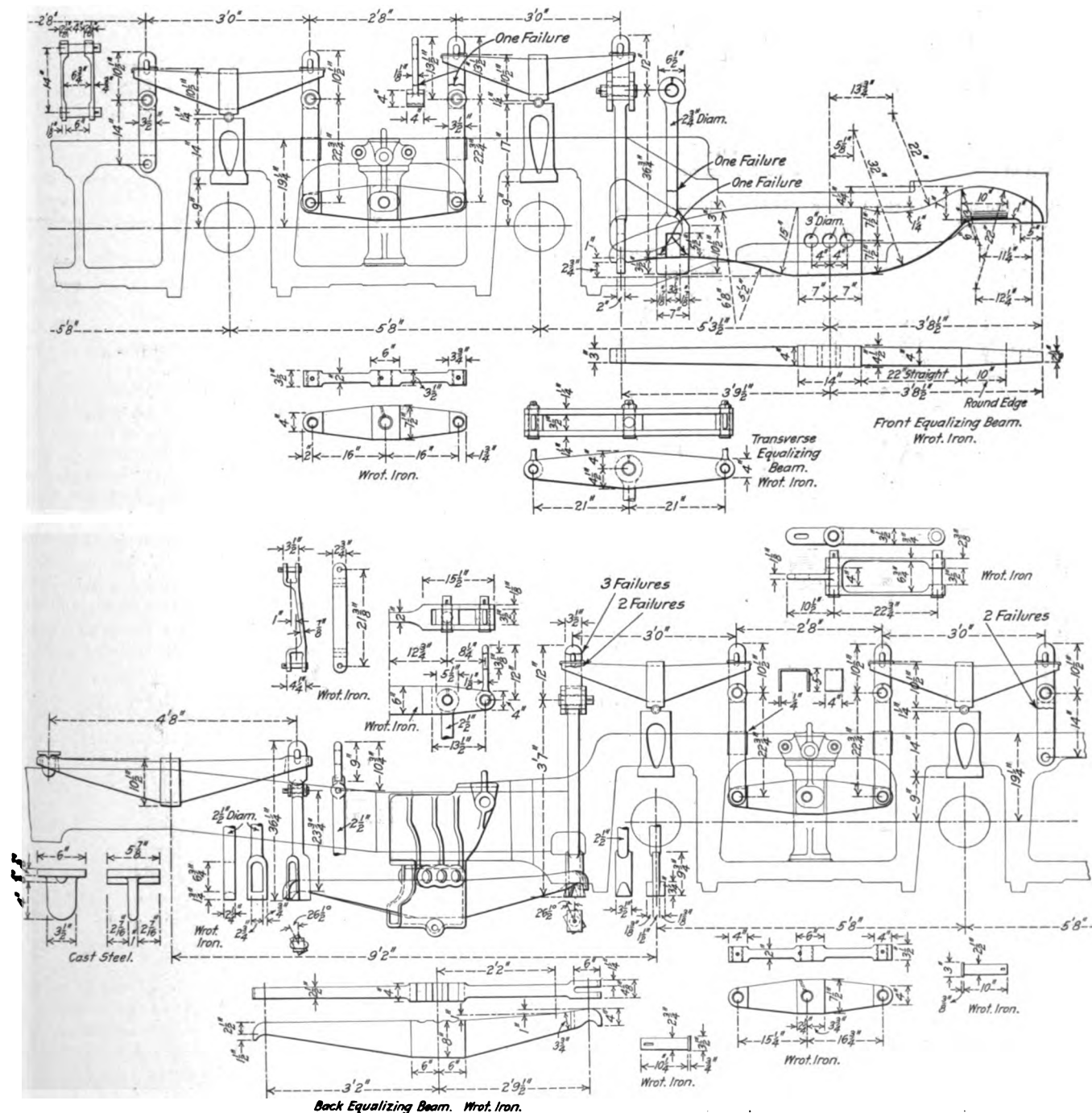

Fig. 1—Mikado Type Locomotive Spring Rigging That Has Given Trouble from Failures

engines have a tractive effort of 57,000 lb. The arrangement of the spring rigging is shown in Fig. 1. The chief trouble has been experienced with the spring hangers breaking in the fillet at the upper bosses. A study of the design was made with a view of

stress of about 8,000 lb. per sq. in. while the stress on the hanger, which transmits the load to the equalizer, is only 2,740 lb. per sq. in., which would indicate that the equalizer should fail first. Hangers which have worn 20 per cent below size on account of

rubbing on the frame have also shown indications of falling at the fillets at the upper boss. From the engine failure reports and from an inspection of the hangers taken from a roundhouse scrap pile, it has been found that all hangers have broken close to the boss; that hangers with bosses of different lengths have broken at the end of the longer boss, and all hangers not completely broken off show a bending at the cracked section, the crack be-

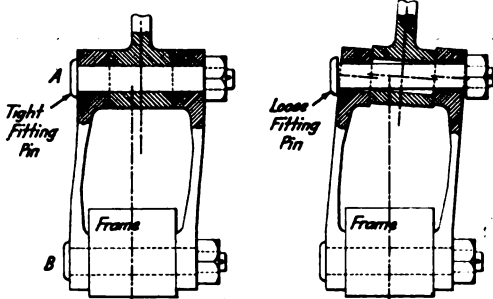

Fig. 2

Fig. 3

Bending of Spring Hangers Due to Side Motion of the Rigging

ginning on the inside of the hanger. This would seem to clearly indicate that the hangers are broken by bending, as the failures occur at the section having the largest bending moment. In comparing these hangers with those of other engines of approximately the same weight, and whose spring rigging is of the same design and material, it was found that the hangers on the Mikado locomotives had a longer boss. Since the other engines have not

bending of a beam fixed at both ends. Fig. 3 shows the probable manner of bending when the pin is a loose fit. The action here is similar to that of a beam fixed at one end and loaded at the other. In Fig. 3 the bending moment from the side motion is opposed to the bending moment due to the eccentric loading. It is plain that the hangers do not fail from this side bending, because this is greatest at the frame, whereas the hangers fail at the upper boss. The effect of this side motion is to produce an eccentric loading, the moment from which is a maximum at the upper boss, the point where the failures occur. The same reasoning applies to the hangers whose lower ends are fastened to the equalizer. Conditions which will give rise to bending moments great enough to produce stresses far above the material's elastic limit

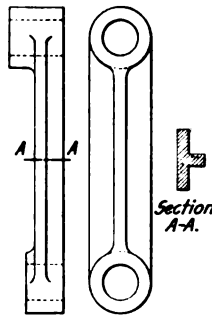

Fig. 5

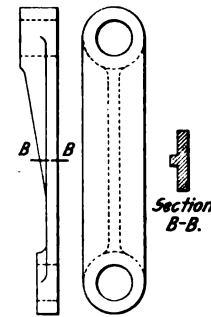

Fig. 6

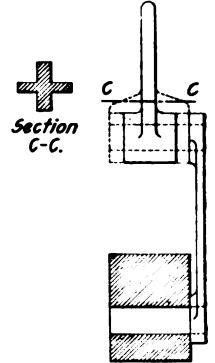

Fig. 7

Designs of Hangers to Resist Bending

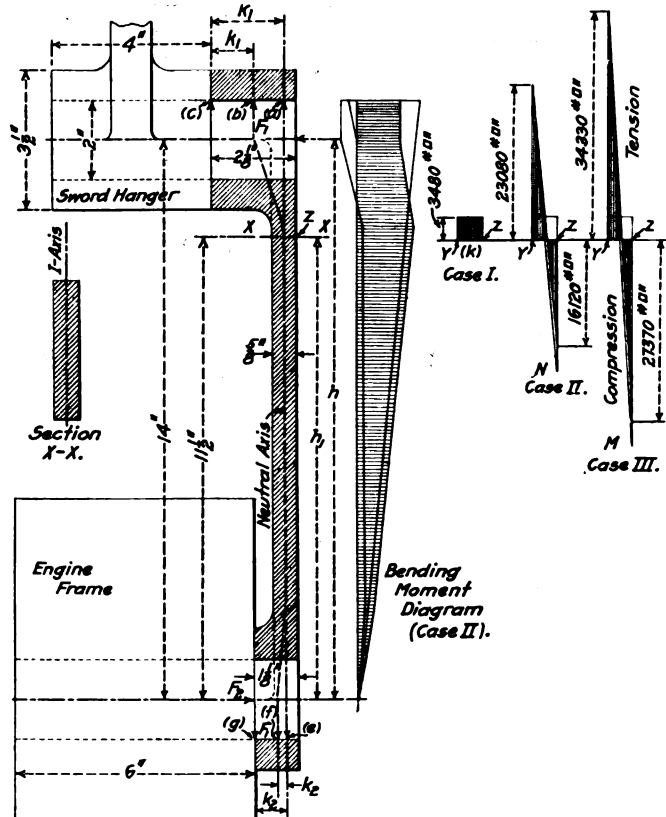

Fig. 4—Diagram of Stresses in Middle Connection Hanger

had this same trouble, it seems right to assume that the long boss is responsible for the failure.

A condition which may produce large bending stresses in a hanger is the sidewise motion of the rigging. This motion is caused by the moving of the driving box upon which the spring saddle rests, or by the elevation of one driver above its mate, relative to the frame. Fig. 2 shows the probable manner of bending when the pin is a tight fit. The bending here is similar to the

are, when the center line of the pin is inclined to the center line of the hole; when the pin fit in the hanger is tapered; when the pin is bent and when the hole in the hanger is tapered. The stress in the body of a spring hanger is the resultant of a direct tensile stress and of a stress due to bending. The bending occurs whenever the reactive forces at the top and bottom bosses have lines of action displaced from the neutral axis of the hanger.

The middle connection hanger which fastens to the frame is the one whose stresses will be determined here. This hanger is shown in Fig. 4, the component bending moments being taken from forces taken below the section. Distances to the right of the vertical axis represent counter-clockwise, and to the left clockwise, moments. Three conditions will be considered.

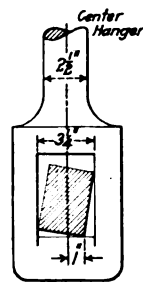

Fig. 8



Fig. 9

Front Center Hanger Under Eccentric Loading

CASE I.—The lines of action will be considered as passing through the neutral axis of that part of the hanger exclusive of the bosses. This represents the most favorable condition.

CASE II.—The lines of action will be considered as passing through the middle points of the two bosses.

CASE III.—This case represents the most unfavorable conditions—lines of action on the inside edges of the bosses.

The reactive forces as shown in Fig. 4 are equal and are designated by F_1 at both top and bottom. In cases II and III these forces form a couple. Since the algebraic sum of the horizontal forces must be zero, the forces of the opposing couple are equal, so they are designated by F_2 at both top and bottom.

Value of F_2 .—For case I, F_2 equals zero. For cases II and III, by equating opposing couples we have,

$$F_2 h = F_1 k, \text{ where } h \text{ and } k \text{ are moment arms.}$$

$$\text{Therefore, } F_2 = F_1 \frac{k}{h} \dots\dots\dots (A)$$

The bending moment at any section distant h_1 , from the center line of the lower pin hole is:

$$M = F_1 k_2 + F_2 h_1$$

Substituting the value of F_2 from (A)

$$M = F_1 k_2 + F_1 \frac{k h_1}{h} = F_1 \left(k_2 + \frac{k h_1}{h} \right) \dots\dots\dots (B)$$

CASE I

Value of F_1 .—The force transmitted to each spring hanger equals the weight per driver minus the weight of the wheel including the weight of the side rods, one-half the weight of the axle, the weight of the box, the weight of the saddle and the weight of the spring, the remainder to be divided by the number of hangers per spring. In the present case this force is 6,000 lb. or 2,740 lb. per sq. in. The distribution of stress at section XX, Fig. 4, is shown at K.

CASE II

For this case there is a tensile stress and a stress due to bending:

$$\text{The bending moment} = F_1 \left(k_2 + \frac{k h_1}{h} \right)$$

$$\text{Substituting: } F_1 = 6,000 \quad k_2 = 0.25 \text{ in.}$$

$$h_1 = 11.5 \text{ in.} \quad k_1 = 0.75 \text{ in.}$$

$$h = 14 \text{ in.} \quad k = k_1 - k_2 = 0.5$$

$$M = 6,000 \left(0.25 + \frac{0.5 \times 11.5}{14} \right) = 3,530 \text{ in. lb.}$$

Since the section is symmetrical about its I-axis, the section modulus in tension will be the same as that for compression:

$$Z = 1/6 bd^2 \quad b = 3.5 \text{ in.} \quad d = .625 \text{ in.}$$

$$Z = \frac{3.5 \times .625^2}{6} = .228$$

Let S_{bc} = compressive stress due to bending
 S_{bt} = tensile stress due to bending

$$\text{Then } S_{bc} \text{ and } S_{bt} = \frac{M}{Z} = \frac{3,530}{.228} = 15,500 \text{ lb. per sq. in.}$$

As in Case I, the direct tensile stress = 2,740 lb. per sq. in. The resultant stresses are:

$$\text{Tensile} = 15,500 + 2,740 = 18,240 \text{ lb. per sq. in.}$$

$$\text{Compressive} = 15,500 - 2,740 = 12,760 \text{ lb. per sq. in.}$$

The distribution of stresses at section XX for this case is shown at N, Fig. 4.

CASE III

For Case III we have:

$$F_1 = 6,000 \text{ lb.} \quad k_1 = 1.8125 \text{ in.}$$

$$h_1 = 11.5 \text{ in.} \quad k_2 = 0.8125 \text{ in.}$$

$$h = 14 \text{ in.}$$

Substituting in (B) and solving:

$$M = 5,560 \text{ inch-pounds, bending moment,}$$

$$\text{and } S_{bc} \text{ and } S_{bt} = \frac{5,560}{0.228} = 24,400 \text{ lb. per sq. in.}$$

$$\text{Resultant tensile stress} = 24,400 + 2,740 = 27,140 \text{ lb. per sq. in.}$$

$$\text{Resultant compressive stress} = 24,400 - 2,740 = 21,660 \text{ lb. per sq. in.}$$

The distribution of stresses for this case is shown at M, Fig. 4.

On hangers having a narrow boss, the bending moment may be neglected when a generous factor of safety is used. But with a wide boss the usual factor of safety is not great enough to provide for the stress not considered in the design. The length of the boss on the Mikados is $2\frac{3}{8}$ in.; this is $\frac{3}{8}$ in. greater than on the next size below. It seems improbable that these hangers should fail by direct tension, as case I gives a factor of safety in tension of about 12. An increase in hanger stress means an increase in driving box reaction and an increase in reaction between the driving wheel and rail. Any force on a driver great enough to break a spring hanger would also break a rail if applied between the ties.

Two general methods suggest themselves for overcoming the difficulty: First, design the hanger so that it will be able to resist the bending moment, as shown in Figs. 5 and 6; and second, use a

construction which will practically eliminate the bending moment, and still design the hanger for tension, as in Fig. 7.

The usual construction brings a bending moment on both the sword and the long hanger. They should both, therefore, be made to withstand bending. In Fig. 7 practically all the bending comes on the sword hanger which is made to resist it, while the long hanger is subjected to tension and is designed accordingly.

Fig. 8 shows how an eccentric loading may be brought on the front center hanger by an inclination of the hanger or equalizer.

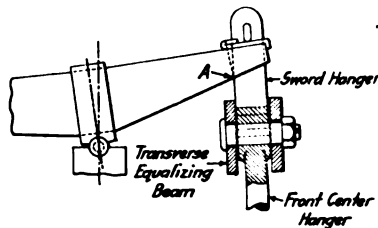

Fig. 10—Showing Restricted Movement of Sword Hanger in Spring

The vertical load on this hanger is 24,000 lb. If the load is supported 1 in. from the center the bending moment will be:

$$24,000 \text{ lb.} \times 1 \text{ in.} = 24,000 \text{ in. lb.}$$

$$Z = \frac{\pi D^3}{32} = \frac{\pi \times 2.5^3}{32} = 1.4$$

$$p = \frac{M}{Z} = \frac{24,000}{1.4} = 17,000 \text{ lb. per sq. in.}$$

The tensile stress will be increased by the direct tension, which is:

$$\text{Area of hanger} = \frac{\pi D^2}{4} = \frac{\pi \times 2.5^2}{4} = 4.9 \text{ sq. in.}$$

$$\frac{24,000}{4.9} = 4,800 \text{ lb. per sq. in.}$$

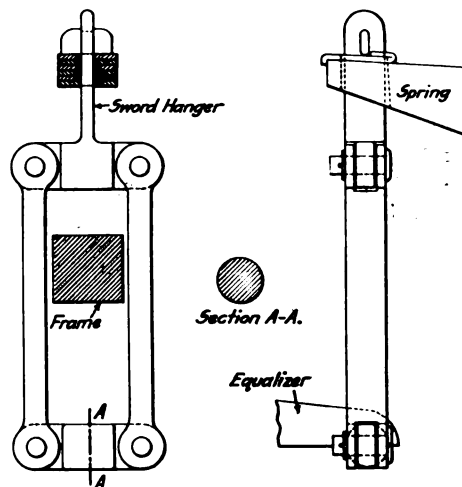

Fig. 11—Suggested Arrangement of Spring Hangers to Provide Flexibility

Therefore, the maximum tensile stress = 17,000 + 4,800 = 21,800 lb. per sq. in. As this hanger is free to move sidewise it would probably assume the position shown in Fig. 9 under an eccentric loading. That is, the hanger would swing until the line of action of the loading would pass through the center of the upper supporting pin. The bending moment would then be greatest at the bottom. An inspection of the front equalizing beams on the Mikado engines shows a great many of them apparently inclined. But if there is an even bearing of the center hanger on the beam for some particular position of the rigging, any side movement must necessarily produce an eccentric loading.

Fig. 10 shows how a restricted movement of the sword hangers in the spring will cause eccentric loading on the front center hanger. Under a large vertical movement of the spring the sword hanger will strike at the point A. This brings a bending moment on the hanger, but the force producing it is compara-

tively small and the hanger is strong against bending in this direction as its section is deep. Its serious effect is to prevent the pin from alining itself with the front center hanger, and in forcing the front transverse beam forward, while the center hanger tends to force the other transverse beam backward. Inspection of these hangers shows indentations, indicating that they have borne against the spring. The wearing of the holes into an oblong shape is probably due to the high bearing stress.

The short hangers which fasten to the frame have a boss 1 1/8 in. long, with a hole 2 in. in diameter, giving a projected area of 2 1/4 sq. in. As each hanger bears 6,000 lb., the unit pressure will be:

$$\frac{6,000}{2.25} = 2,700 \text{ lb. per sq. in. of projected area.}$$

This stress is great enough to actually crush the metal outward, and as these bearings are practically free from lubrication, very slight movements will produce rapid wear.

Fig. 11 shows an arrangement which might be used to advantage. Here the hanger pins are placed lengthwise with the frame instead of across it. This will permit the hangers to adjust themselves to the side motion of the rigging without subjecting themselves to bending or to eccentric loading. In this arrangement the movement of all the members is such as to eventually wear for themselves the longest possible bearing. This is in contrast to the present rigging, where the spring hanger cannot have a bearing along the entire length of its boss except in one position of the rigging. The side movement of the present rigging does not tend to wear the broadest possible bearing for the boss.

The lack of what might be termed "transverse flexibility" in the present spring rigging is probably its greatest defect. There is no question about the side movement of the hangers. The excessive wear on the frame shows this. Furthermore the side motion of the drivers and the elevation of one above the other is considered in the design of the driving boxes. The spring saddle rests upon the driving box and the spring upon the saddle, so that any movement of the box must be transmitted to the spring. The box is designed for tilting, but the spring rigging for no side motion. This seems inconsistent. There is a certain amount

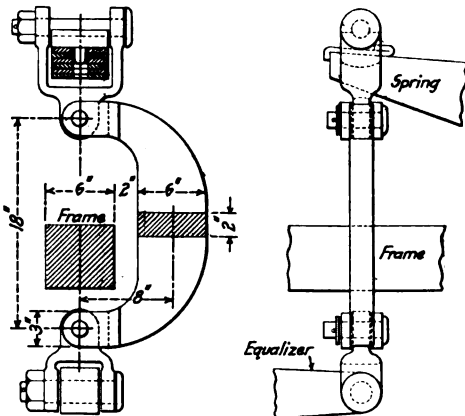

Fig. 12—Another Spring Hanger Suggestion

of play at the hanger pins, but this will produce a bending moment which the hanger is not designed to resist.

One end to be sought in designing a spring hanger is to make one which will last the life of the locomotive. This is utterly impossible at present. Even were a hanger made which would not be bent by side motion as in Fig. 11, or which would resist an eccentric loading, its life would be limited by wear on the frame or on the frame protectors, when in place. Frame wear cannot at present be avoided because of the small clearance between the frame and the drivers. The defects of the present arrangement may be summed up as follows: Poor oiling facilities; frame wear cannot be avoided because of the small clearance between the frame and the inside of the driver; non-flexibility in a transverse direction, except at the expense of bending

the hanger directly and by eccentric loading; side motion of the rigging will not tend to wear flat bearing surfaces, and the life of the hanger is limited by wear on the frame.

In the arrangement shown in Fig. 12 the present tension arrangement is abandoned and a single member is placed on the inside of the frame, being subjected to direct tension and bending. The pins are placed lengthwise with the frame to permit side movement. The wear of the members in Fig. 12 is such as

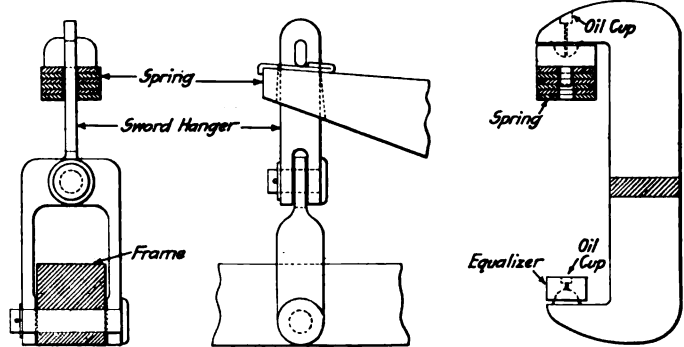

Fig. 13

Fig. 14

Suggested Designs for Short Hangers

to eventually give a bearing as long as the boss. As the hanger is placed inside of the frame, the clearance between itself and the frame can be made large enough to avoid wear. The stress in such a hanger would be:

$$12,000 \times 8 = 96,000 \text{ in. lb. bending moment}$$

$$\text{Section modulus} = \frac{2 \times 6^3}{6} = 12$$

$$p = \frac{M}{Z} = \frac{96,000}{12} = 8,000 \text{ lb. per sq. in. from bending}$$

$$\frac{12,000}{2 \times 6} = 1,000 \text{ lb. per sq. in. in direct tension}$$

$$8,000 + 1,000 = 9,000 \text{ lb. per sq. in. maximum tension}$$

If an I-section were used in Fig. 12, a larger section modulus could be obtained, giving a lower stress for the same section area.

Fig. 13 shows an arrangement which would give transverse flexibility to the short hangers when using the usual sword hanger. A ball bearing should be used on the front equalizing beam, and the sword hangers connected to the transverse equalizing beam should have freedom of movement. Fig. 14 shows an arrangement for using a ball bearing at the spring and at the equalizer. The possible objections to this would be: Liability to unseat; liability to turn and be subjected to bending in a direction in which it is weak; high bearing stress; great weight, and that it does not hold the spring on its seat by restricting its side motion.

However, the ball bearing arrangement would no doubt be as firm on its seat as is the spring on its pin. It could be prevented from turning by a forked member thrown loosely over opposite hangers. The bearings could be removable, and made of specially hardened material so as to stand a high bearing stress. The weight should be no objection if they did not fail and need to be replaced in roundhouses.

The advantages of the arrangement shown in Fig. 14 are: Good oiling facilities; simplicity; will eliminate wear of itself or the frame by proper selection of clearance; ideal flexibility without subjecting itself to bending or eccentric loading; stresses can be accurately computed, and as a result of the previous advantage there should be no engine failures from broken hangers.

Possibly the greatest objection to a single hanger used to connect the spring with the equalizer is its weight, but this objection should disappear if it will eliminate hanger failures and wear on the frame. An inspection shows that the frame is worn because only about one-half of the frame protectors are in place. The others are either torn loose from the frame or else have the side broken off. But heavy as it must be, it would harmonize with the design of a heavy locomotive.

CAR DEPARTMENT

LUBRICATION OF CAR JOURNALS*

BY W. A. CLARK

General Car Foreman, Duluth, Missabe & Northern, Proctor, Minn.

The lubrication of car journals should be investigated systematically, the results summarized and used as a guide in practice. The bearing surfaces of both the journals and brasses must be smooth and true, the brasses being large enough and of sufficient strength to resist spreading or closing, when they are subjected to the maximum pressure of the service in which they are used. The wedges should be of correct dimensions. If they are too large, having a crown bearing only, the load will be concentrated, causing excessive friction which, in turn, will cause the rapid heating of the brass and journal. Under high capacity cars, wedges with only a side bearing will cramp the brass to the side of the journal and cause excessive heating.

Oil boxes are a factor in lubrication. There are a variety of designs, shapes and sizes. Different results are obtained from the extremes in either case. Some boxes are very narrow, making it difficult to place or keep the sponging in its proper position. There are other boxes considerably larger that allow the sponging to become disarranged to such an extent that it soon works away from the journal. Then, again, there are boxes in which, when properly packed, the sponging will have very little movement.

When excessive journal friction develops, trouble manifests itself when the temperature rises more rapidly than it can be dissipated by the metals in the box. This causes the oil to volatilize, preventing it from reaching the parts under pressure. This increases the friction, thus increasing the heat until the brass breaks or melts. With the journal bearing surface destroyed the heat will increase until the journal is burned off or broken. The trucks should be square and true, otherwise the brasses may be forced against the box or fillets, or against or on top of the collars. The box may be out of line with the result that heating will occur in proportion to the freedom that the brass has, or the amount that the truck is distorted.

There are a number of causes with a combination of conditions other than a lack of oil that will produce hot boxes. One of the principal causes is the moving of the sponging or packing away from the journal. The lateral movement of the axle forces the packing away from the inside or fillet end of the journal. It must follow that a surface in contact, under pressure and revolving, will generate heat at the point where the packing and oil do not touch the journal. This heat is conducted to the full length of the bearing and in time causes a hot box. This is a difficult condition to detect from an outside examination of the box. It can be corrected by using the packing spoon to replace the packing in the back end of the box and in contact with the full length of the journal.

The oil box as used on railway equipment cannot be even one-quarter filled with oil as the hole in the back of the box is about 1½ in. from the bottom. This should show the necessity of having a good grade of saturated waste placed and kept in the proper position in the oil box. It should be a practice when examining boxes, or when they show signs of heating, to use a packing spoon to put the sponging back in contact with the journal. The most important element in the lubrication of car brasses is that the oil be conveyed to every part of the journal.

Axles and journals as now made from steel give little trouble. The percentage of hot boxes originating from journal defects is small. The brass or bearing has a direct influence on the man-

ner in which a journal will run. Every precaution should be taken to procure a perfect fit with a grade of bearing metal suitable to withstand severe service. In following up and investigating hot box reports a number of brasses that caused trouble were examined. In nearly every case the lining had worn away at the center and not at the ends of the brass, due to a variation in the structure. On breaking the brasses longitudinally for examination they were found to consist at the center of a mixture different from that at the ends. Others were found that were not solid, or had longitudinal fissures or flaws. The difference in the rigidity of the metal produced an unequal distribution of the pressure. The question of foundry practice, or the care exercised in manufacturing car brasses, is one of the most important features in furthering perfect lubrication. Dross or sand when mixed with the bearing metal causes unequal hardness, or what are termed "hard spots." As the soft metal wears away, concentrating the pressure on the hard spots, excessive friction will be caused, producing a rapid rise in temperature and ultimately a hot box. The only remedy for this trouble is to change the brass. It would seem proper to use a high grade of metal for the lining of car brasses. A more general investigation of this subject would undoubtedly be the means of showing the importance of the proper mixtures for journal bearings in heavy capacity car service.

The linings in use on the European railways are made from copper, tin and antimony, and may be considered as having tin as a base. The general American practice is to use lead and antimony or lead, antimony and tin or a lining with lead as a base. A dynamometer car test of from 65 to 80 cars with bearings with lead linings, as against tests of cars with bearings made from babbitt, or of copper, tin and antimony, or copper, tin, antimony and lead, would probably show some surprising results in an increase or decrease in journal friction, abrasion and fuel, thus showing the advantage of a tough homogeneous anti-friction car brass lining. It is my opinion that a field is open for investigation in the matter of the comparative wearing and frictional qualities of different mixtures of metal. With a 70-car train we have 560 car journals. With a small decrease or increase of friction per journal, a noticeable loss or saving on brasses, journals and fuel would be effected. There is one point that would have to be considered in a test as suggested, and that is, that the trains be equipped with anti-friction side bearings of the same pattern in order that flange friction may not be confused with journal friction.

The road track conditions, or even yard tracks with high or low joints affect the condition of the packing. There will be fewer hot boxes on cars moved over good tracks than on those that travel over rails not in as good alinement. The handling of cars also has an effect on the trucks and inasmuch as the brass is affected by every movement of the truck, it must follow that all shocks are transmitted to the brass.

Trouble will also occur when the packing has become ground up and reduced to a pulp, or when the strands have become so short that proper capillary action cannot take place to convey the oil from the bottom of the box to the journal. When boxes are packed too tight so as to shut off the flow of oil it causes a wiping action instead of lubricating the journal. When the packing is too loose it falls away and settles down below the journal. Also, when the packing has become glazed from dirt the flow of oil to the journal is retarded, or when the packing has too large a percentage of oil it becomes heavy and soon settles away from the journal.

After hot box compound that has been used on a hot journal becomes cool it will make the packing a hard, solid mass like

*From a paper presented before the Missabe Railway Club, Proctor, Minn., November 30, 1914.

grease, shutting off the flow of oil from the bottom of the box. Packing in this condition invariably causes trouble if it is not removed at destination. Hot box compound is intended to be used only when journals show signs of heating beyond the point where car oil will not lubricate (a certain temperature, about 300 deg. F., at which car oil vaporizes or passes off in the form of a gas or smoke). It is made from mixtures that do not volatilize at as low a temperature as car oil. However, on account of its damaging effect on the packing after the journal has become cooled, it should be used sparingly and only on journals that car oil will not lubricate.

Many train delays would be avoided if prompt attention could be given to journal boxes when they first show signs of heating, thus saving broken brasses, cut journals and the setting out and picking up of cars. Delays and hot boxes can be reduced to a minimum by all concerned giving attention to the details, particularly to the condition of the packing. The oil boxes on this road are being systematically repacked. The waste and oil removed is cleaned, special attention being given to retaining the oil in the box. The packing is in better condition and more oil is in the boxes than at any time heretofore.

In view of the possibility of a box or boxes having some or all of the packing removed, a brass or wedge cracked or broken, and the large number of other causes that bring on the heating of journals, it would seem that, from an operating and safety standpoint, no train should be allowed to run very many miles from its starting point until the crew are given an opportunity to satisfy themselves that all the journals are running cool.

The suggestions as outlined are intended to bring to the notice of those who may be interested in this subject the fact that the lubrication of modern railway cars is worthy of more than a passing interest if a reduction of train resistance is desirable.

NO "GREATEST DEFECT" IN BOX CARS*

BY CHARLES E. WOOD

Foreman Freight Repairs, Union Pacific, Armstrong, Kan.

What is the greatest defect in box cars and how can it best be remedied? The answer depends entirely on the point of view. The train and engine men, if asked, would without any hesitation refer to our old friend, the draft gear problem; the claim department would say leaky roofs; the freight house men and those having to do with loading and unloading would swear by and at the side doors which will not open or close; while the air brake inspector thinks he has all the trouble in his effort to maintain his 85 per cent of efficient brakes. Each branch has its own particular complaint to register, but when we get to the car repair foreman, who gets the cars in the shop for each and every ill that the box car is heir to, he is at a loss to place his finger on any defect and say it is the greatest.

During the past few years great strides have been made in freight car construction, and as each succeeding sample car comes to us, we look it over and try and locate the weak spots and say, "At last we have the car that will stand; it is hard to see wherein it could be improved." But after a few months service we find a faulty piece of designing and consequent trouble developing at a point where we least expected it.

It was suggested in the announcement of the competition by the *Railway Age Gazette, Mechanical Edition*, that the draft gear question be left out, and it has been very thoroughly covered in recent issues. I would just state in passing, however, that the champions of the friction gear are not found among the freight repair men. H. C. Priebe, in the September issue, page 453, voices, I believe, the sentiments of 75 per cent of the car foremen of this country.

I believe that next to the draft rigging the roof is the greatest source of trouble. Designs which were thoroughly satisfac-

tory 15 years ago are now worthless and do not last over a year or so. We will have to get away from the combined wood and metal roof and develop the all-metal roof until we have brought it to the required state of perfection. There are a number of good all-metal roofs now being tried out, and after a little more experience with them we should have a roof which will be thoroughly satisfactory.

Unfortunately, the side door and its stubbornness is a feature on which we do not appear to be making much progress. It is true, we have more elaborate and costly fixtures than we had in the old days, but it is also true that we have more trouble with the side doors than we did then. It is admitted that the size of the doors has increased considerably, thus making the designing of efficient hangers a much more difficult matter; but the fact remains that in spite of all the inventive genius which has been brought to bear on this subject, we are far from having a satisfactory door on our box cars. If anyone doubts this statement, he has, in order to be convinced, only to go into any freight yard and try to open a few doors unaided. It would appear that we will have to sacrifice the most desirable feature of having a water tight and dust proof door to providing one which can be operated without the use of pinch bars, relying upon temporary stripping for protection when the contents are of such a nature that this action is necessary.

The air brake is now in such a highly perfected condition that it would appear almost sacrilegious to offer any criticisms upon this, but so much of its efficiency depends upon proper maintenance that it is imperative that it should receive our best attention. The regular and systematic draining of main reservoirs will go a long way toward keeping the triple valves in better condition. "Water in triple valve" is too often the cause of defective and inoperative brakes. Piston packing leathers, too, should be renewed as soon as defective; they are too often overlooked and investigation will show that fully 50 per cent of our defective brakes are due to packing leathers being worn out.

The end construction of box cars in general has left a great deal to be desired. Broken end posts, ends bulged out, etc., are prolific causes of bad order cars. A great many remedies have been tried out; end posts have been reinforced with iron plates; end truss rods have been applied, but the shifting load was irresistible and all our best designs went down to defeat. But the advent of the all-steel end bids fair to overcome this difficulty, and the increased first cost will be more than justified in the saving on repairs.

The improvements in truck designs have kept pace with the car body. The arch bar truck has had a long reign, and cracked arch bars have caused many a bad derailment. The maintenance of nuts on column and journal box bolts has always been difficult, but very necessary from a safety standpoint, and their elimination by the solid cast steel truck sides, which are now in general use on new cars, has lifted a heavy burden from the car inspectors and foremen.

In conclusion, the many improvements being made show that the car department is not behind the locomotive department in its effort to keep pace with modern requirements, but is always on the alert to overcome the weak spots, and if each railroad will do its share of ridding our rails of the light wooden underframe cars, and also reinforce the earlier steel underframe cars, some of which are proving to be entirely too light, it will become increasingly difficult for anyone to pick out the greatest defect.

THE DIAMOND IN STEEL BORING.—In extending the use of the diamond to boring hardened steel it was found that the diamond seems to act equally well at almost any ordinary boring speed, as long as the depth of cut is not sufficient to catch the cutting edge and spring the bar. The speeds and feeds seem to be about the same as in using a steel tool on soft steel, although it is possible that a higher speed might be maintained should it be found desirable.—*American Machinist*.

*Entered in the car department competition which closed October 15, 1914.

STEEL COACHES FOR THE SANTA FE

New Passenger Equipment 70 Ft. Long Over End Sills; Day Coach Seats 83 Passengers, Chair Car 76

The Atchison, Topeka & Santa Fe has received from the Pullman Company 76 coaches and 49 chair cars of all-steel construction, which were designed in the office of the engineer of car construction of the Santa Fe, and represent distinctly Santa Fe practices. The principal details are practically identical for both types of cars. The interior arrangement is the same, with the exception of the seats and an additional sink opposite the women's saloon in the chair cars, which is provided with hot and cold water and was installed for the convenience of women passengers traveling with children. The coaches will seat 83 passengers and the chair cars 76. The chair cars are used in the transcontinental service. Both types of cars measure 70 ft.

a top and bottom cover plate $\frac{1}{4}$ in. by 8 in., the top cover plate extending entirely across the car, while the bottom cover plate extends only from the center sill to the side sill on the center cross-tie. A pressed steel gusset plate is used in the center cross-ties, as shown in the illustration, to stiffen the lower connection with the center sill. A triangular $\frac{1}{4}$ -in. gusset plate is used at the junction of the top cover plate and the side sill at each cross-tie. This gusset also connects the cross-ties with the diagonal braces, which are of $\frac{1}{4}$ -in. by 8-in. steel plate. Diagonal braces $\frac{1}{4}$ -in. by 8-in. extend from the side to the center sills.

The double body bolsters are made up of double diaphragms of $\frac{1}{4}$ -in. pressed steel, placed back to back and located 21 in.

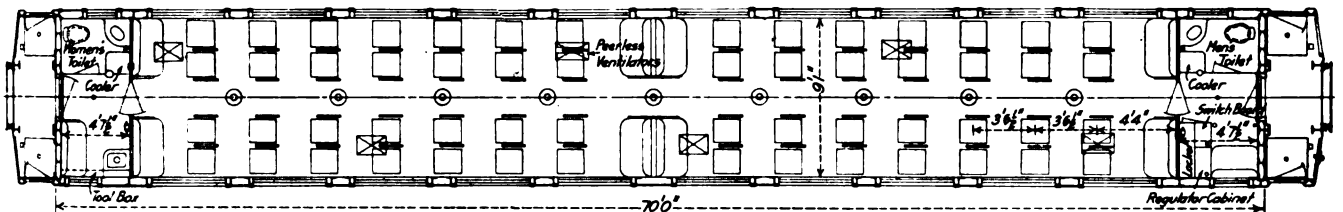

Floor Plan of the Santa Fe Steel Chair Car

over end sills and 77 ft. 8 in. over buffers. The chair cars weigh 13,600 lb. and the coaches 13,400 lb. The inside length is 69 ft. 4 in. and the width is 9 ft. 1 in., the width over side sills being 9 ft. 6 in. The only wood used in the cars is the $\frac{1}{8}$ -in. pine flooring and the window capping. The exterior is painted the new Pullman standard body color, and the interior is finished in imitation dark mahogany, which is enameled and baked.

The construction of the underframe is shown in the accompanying drawings. It is made up entirely of structural steel shapes and steel plates. The center sill is of the fish-belly type, being 2 ft. 8 in. deep at the center for 7 ft. 6 in. each side of the middle of the car. These sills then taper for 16 ft. $4\frac{3}{4}$ in. to a depth of $12\frac{1}{8}$ in. at the body bolster. They extend through-

on each side of the truck center. Similar diaphragms are inserted between the webs of the center sill, as in the case of the cross-ties. At this point each of the center sill girders is reinforced by a $\frac{3}{4}$ -in. by 6-in. bottom cover plate, extending 4 ft. back and 3 ft. 6 in. forward from the center line of the bolster. The bolsters themselves are strengthened by 7-in., 9.75-lb. channels, located 3 ft. $9\frac{1}{4}$ in. on each side of the center line of the car. These braces also support the side bearing of the car body, 3-in. by 3-in. by $\frac{1}{4}$ -in. angles 19 in. long, and a bottom cover plate $\frac{1}{4}$ in. by 6 in. by 15 in. long being applied at the bottom of the channel in the center for this purpose. The body bolsters are further reinforced by a top cover plate of $\frac{1}{4}$ -in. steel 4 ft. 3 in. wide, which extends between the side sills in one piece. A

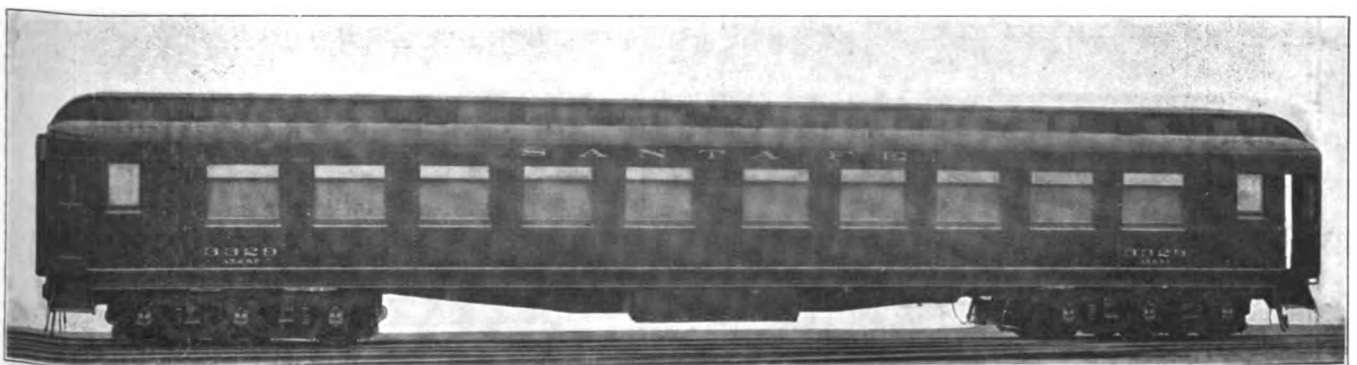

Steel Passenger Equipment for the Atchison, Topeka & Santa Fe

out the length of the car between the vestibule end sills. The girders are 14 in. apart and are made up of $\frac{5}{16}$ -in. plates with two 3-in. by 3-in. by $\frac{3}{8}$ -in. angles at the top and two 3-in. by 3-in. by $\frac{1}{2}$ -in. angles at the bottom. A top cover plate $\frac{1}{4}$ in. thick and 24 in. wide extends the full length of the car. Two center and two intermediate cross-ties are located 5 ft. 3 in. and 15 ft. $2\frac{3}{8}$ in., respectively, on each side of the middle of the car. They are made up of single $\frac{1}{4}$ -in. pressed steel diaphragms which extend between the webs of the center and side sills; a diaphragm of the same material is placed between the webs of the center sill at these points. The cross-ties are reinforced by

bottom cover plate $\frac{1}{2}$ in. by 8 in. is riveted to each set of diaphragms, and large triangular gusset plates of $\frac{1}{4}$ -in. steel connect the bolster with the side sill at the side nearest the end of the car.

The end sill is made up of a $\frac{1}{4}$ -in. pressed steel diaphragm, extending between the center sill and the side sill. This diaphragm has a 3-in. flange to which is riveted a $\frac{3}{8}$ -in. by 8-in. top cover plate and a $\frac{1}{4}$ -in. by 6-in. bottom cover plate, the latter extending across the car from side sill to side sill. The top cover plate is reinforced by a 3-in. by 4-in. by $\frac{1}{4}$ -in. angle, located $3\frac{3}{4}$ in. back from the face of the end sill, and to this

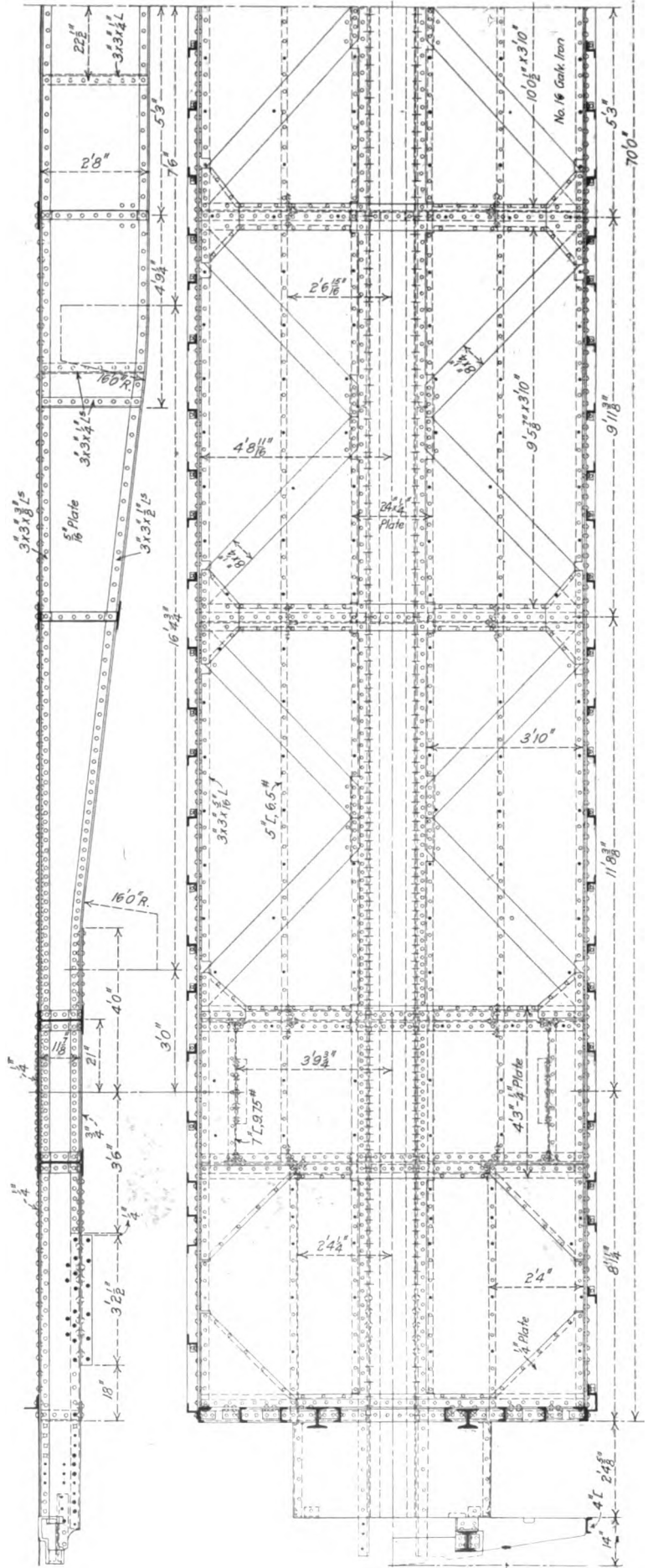
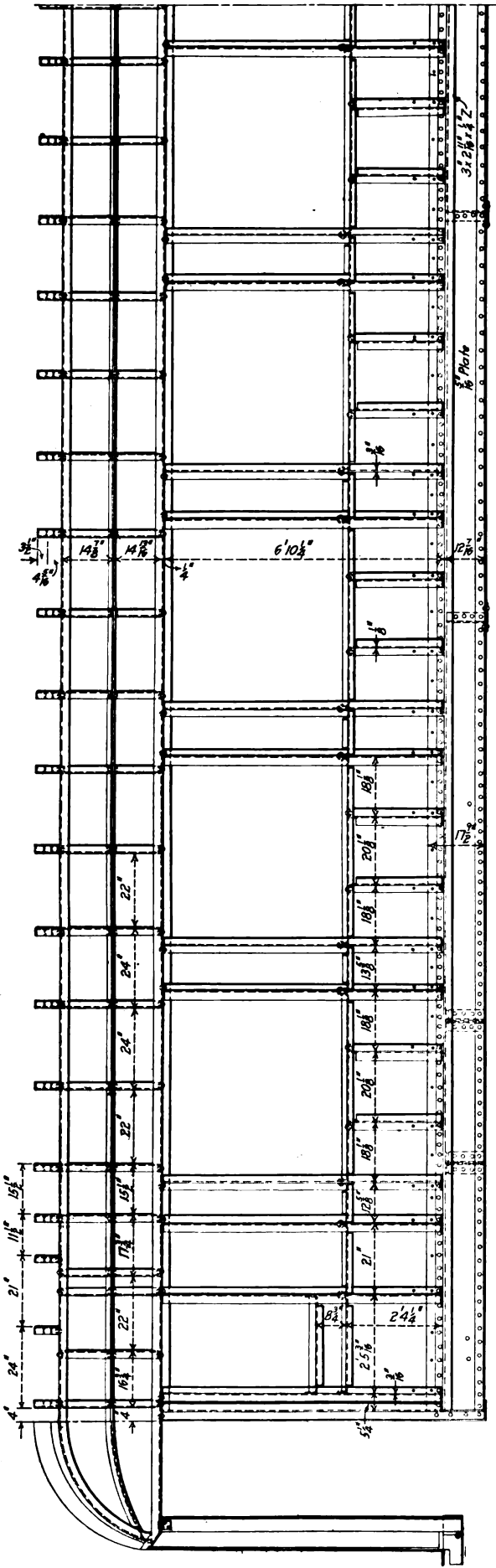

Arrangement of the Framing of the Santa Fe Steel Coaches

are riveted the end posts. Large ¼-in. gusset plates are used to tie the end sill to the side sills. An 8-in., 11.25-lb. channel is located 28¾ in. on either side of the center line of the car and extends between the end sill and platform end sill, which is a steel casting.

The side sills are made up of a 17¼-in. by 5/16-in. web plate, reinforced at the top by a 3-in. by 2 11/16-in. by ¼-in. Z-bar on the outside and a 3-in. by 3-in. by 5/16-in. angle on the inside, and at the bottom by a 3-in. by 3-in. by ⅜-in. angle on the

car. In addition to these I-beams there are six intermediate end posts made up of 4-in., 5.25-lb. channels. The corner posts are made up of 3-in. by 2 11/16-in. by ¼-in. Z-bars, which are reinforced by 5/16-in. by 2 11/16-in. plates, and ¼-in. pressed steel

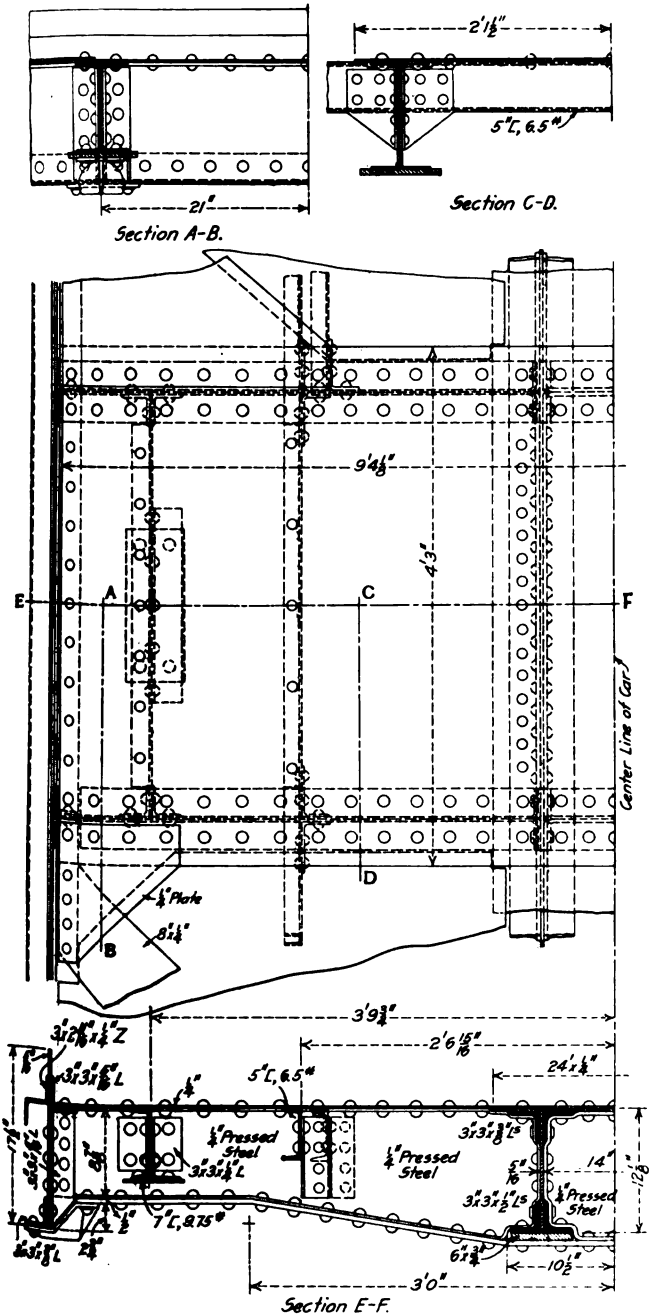

outside. These sills extend between the end sills. The side posts have a Z-shaped cross-section, the through posts being pressed from 3/16-in. steel and the short ones from 1/8-in. steel. The belt rails are 1/8-in. pressed steel of Z-shaped cross-section, the inside and outside sheathing being riveted to the flanges. The side plates are of ¼-in. pressed steel, and also of Z shape, extending through between the vestibule ends.

The end construction is of an anti-telescoping design, two sets of 6-in., 23.9-lb. I-beams being riveted to the end sill, and the platform end sill 22 in. on either side of the center of the

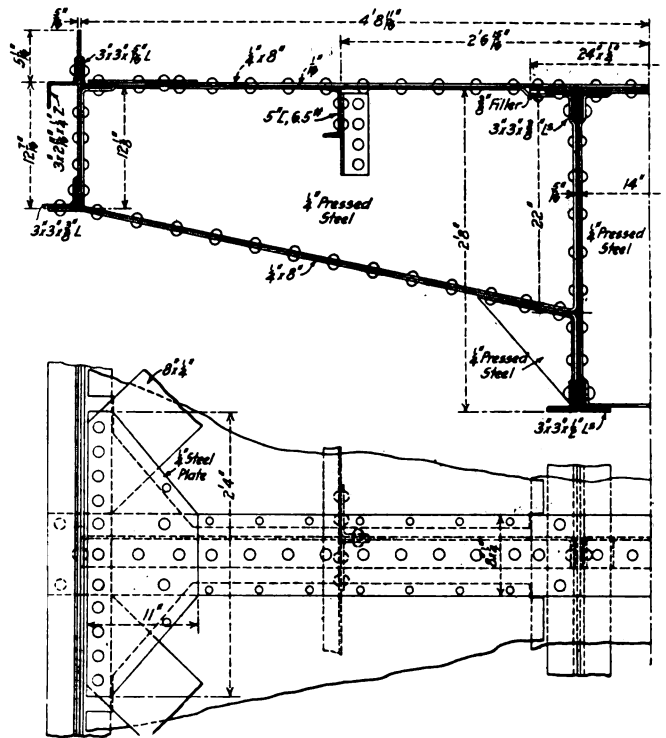

channel-shaped members, with flanges 1¾ in. and 3½ in., a 1¾-in. by 1¼-in. by 1/8-in. angle being riveted to the longer flange. The end posts are secured to the end sill by pressed steel gussets. The end plate consists of a 6-in., 8-lb. channel bent

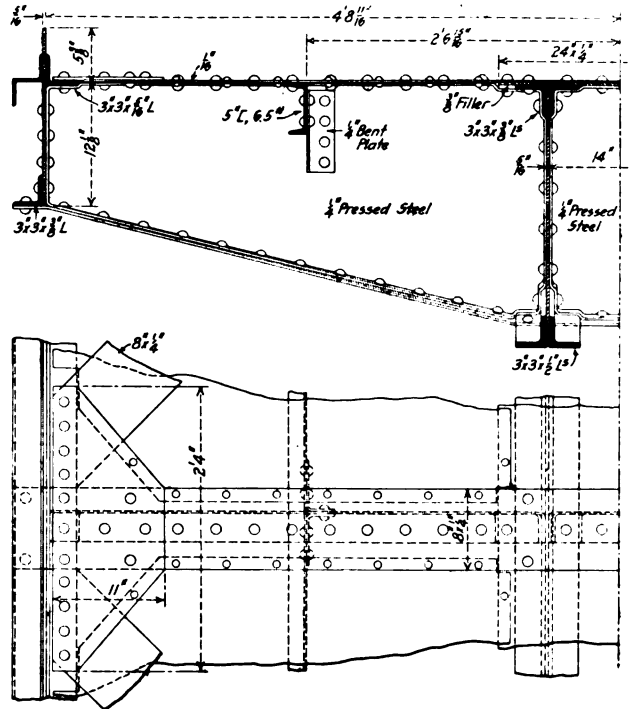

to a radius of 9 ft. from the side plate to the I-beam end post, then continuing straight across to the other I-beam. The upper and lower deck carlines and the deck posts are pressed in the

shape of a channel from 1/8-in. steel. The deck sill is a 3/16-in. by 1 1/2-in. by 8 1/2-in. pressed steel angle. The deck plate is a 3/16-in. pressed steel channel, with flanges 2 1/4 in. and a 5-in. web, the sheathing being riveted to the flanges. The side plate is pressed steel and of Z shape.

In addition to the side and center sills, the floor is supported by a 5-in., 6.5-lb. channel, located 2 ft. 15/16 in. each side of the center line of the car. The underframe is entirely covered by

lead. Flexolith pieces, covered with No. 14 sheet copper, are applied to the sides and ends of the car, except at the toilet rooms. The insulation between the inside and outside sheathing for a few inches above the side sill consists of four courses of 3/4-in. Flaxlinum. The sides, ends and roof of the car are insulated with 3/4-in. Flaxlinum, tightly fitted and held in place between the frame members by No. 20 pressed galvanized iron bands, sprung in place and fastened by 1/4-in. stove bolts. The frame mem-

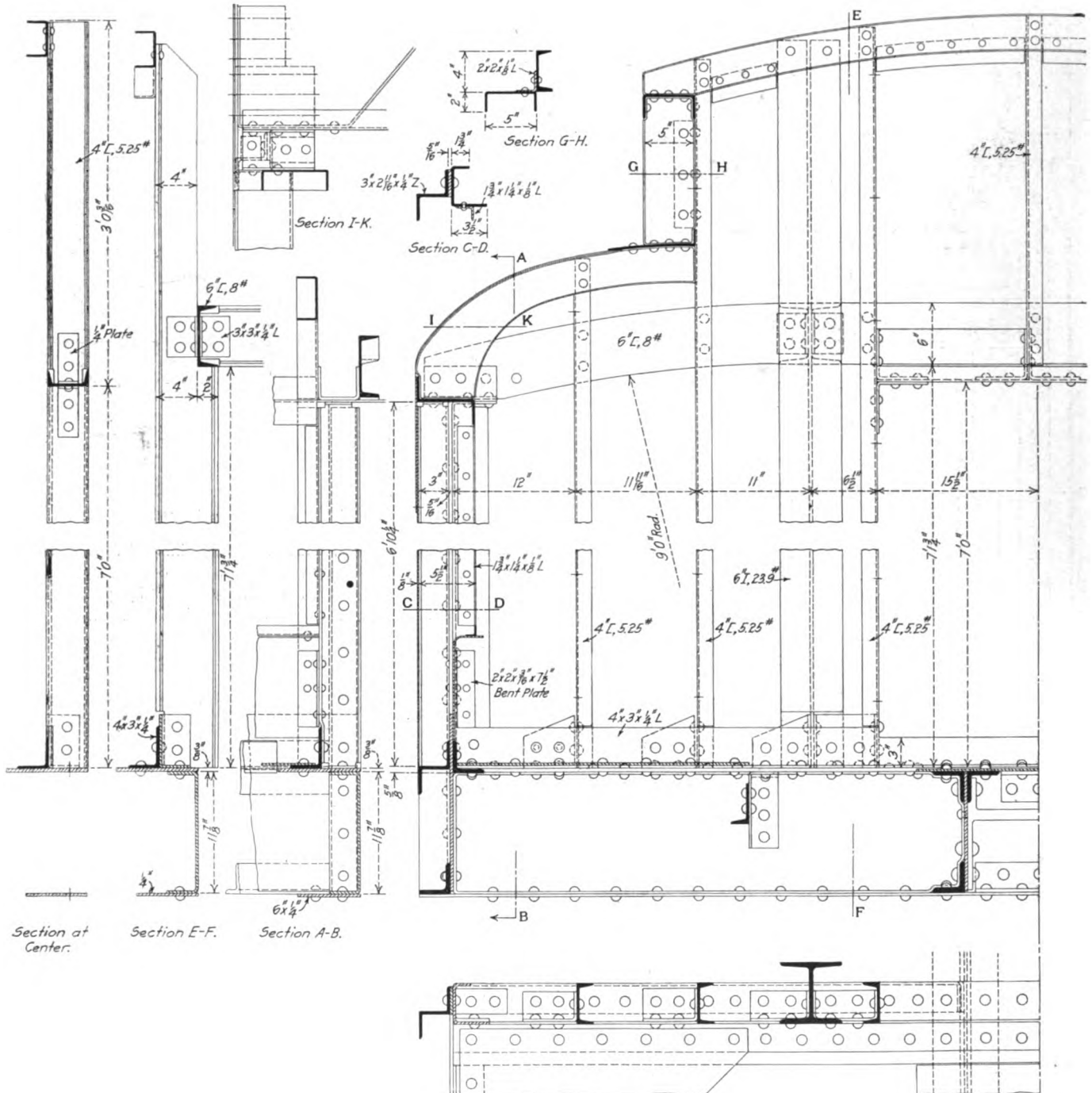

Arrangement of the End Framing of the Santa Fe Steel Chair Cars and Coaches

1/16-in. galvanized steel, which is riveted to the underframe members under the diagonal braces and gusset plates. On top of this is placed a layer of 3/4-in. fireproof Flaxlinum, fitted in between the nailing strips and secured with cleats with 1/2-in. fireproof Flaxlinum under them. A 1 1/2-in. air space is left between this insulation and the floor proper, which is built of 7/8-in. by 3 1/4-in. tongued and grooved yellow pine laid in white

members themselves are insulated with 1/2-in. Flaxlinum, cemented at the edges.

The outside sheathing of the car is 1/8-in. open hearth steel plate, and the inside consists of No. 18 steel plate. The roof sheets of the upper deck are of No. 14 galvanized steel, while those of the lower deck are of No. 16. The roof and hood covering is No. 16 open hearth galvanized steel. The roof sheets

are given one coat of metal roof primer and two coats of metal preserving paint. This is the only part of the exterior of the car that is not sand-blasted before it is painted.

The trucks used on these cars are the Santa Fe standard six-wheel cast steel type, having a 10-ft. 6-in. wheel base and 37¼-in. wheels with 3⅝-in. steel tires. The trucks are provided with Barber rolling center plates and side bearings, Symington journal boxes and L. N., Creco brake beams. Other



Framing of the Santa Fe Steel Passenger Cars

specialties applied to these cars are McCord window fixtures and weather stripping, two North Pole sanitary drinking fountains, Utility ventilators, Gould axle lighting system with Electric Storage Battery Company's batteries, Miner friction tandem draft gear, type A-19 B, and Westinghouse air brakes. Nut locks are applied to all bolts where possible, and where this is not possible the bolts are riveted over. The Chicago Car Heating Company's system of steam heat is used, and as a special feature, two risers of 1¼-in. pipe 16¼ in. long extend up inside the panels, between the windows, from the longitudinal heating pipe. Holes are made in the belt rail, and openings left in the top and bottom of the car to provide a circulation of air at these points.

ERIE CABOOSE WITH STEEL CENTER SILLS

There have recently been placed in service on the Erie a number of cabooses with wooden superstructure and six wooden longitudinal sills, but equipped with steel center sills, body bolsters and end sills. These cars are 28 ft. 6 in. long over body end sills, but the center sills extend through between the striking plates, the distance over the latter being 33 ft. 8 in.

The center girder consists of two 10 in., 35 lb. channels placed 12⅞ in. back to back, and a ¼ in. top cover plate extending the full length. The platform end sill is a 10 in., 15 lb. channel and is connected to the top of the center sill by angles. The body

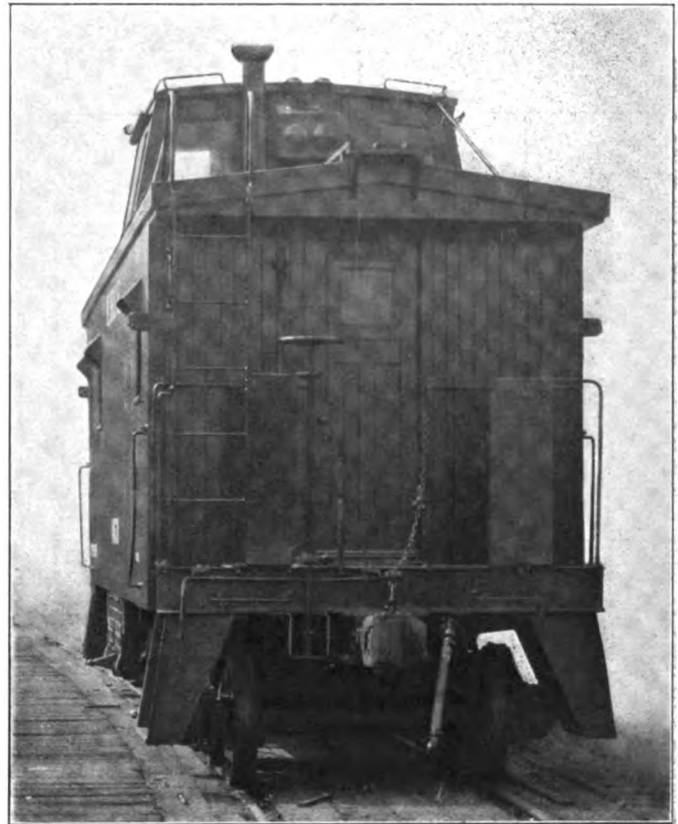

End View of the Erie Caboose

bolsters are built up of ⅜ in. web plates, with 2½ in. by 2½ in. by ¼ in. angles acting as top and bottom flanges on both sides, and a ½ in. top cover plate extending the width of the car. There is also a ½ in. bottom cover plate extending just beyond the side bearings. The truck centers are 22 ft. 2 in. apart.

The wooden sills are 5 in. by 9 in., and rest directly on the cen-



The Steel Members of the Underframe of the Erie Caboose

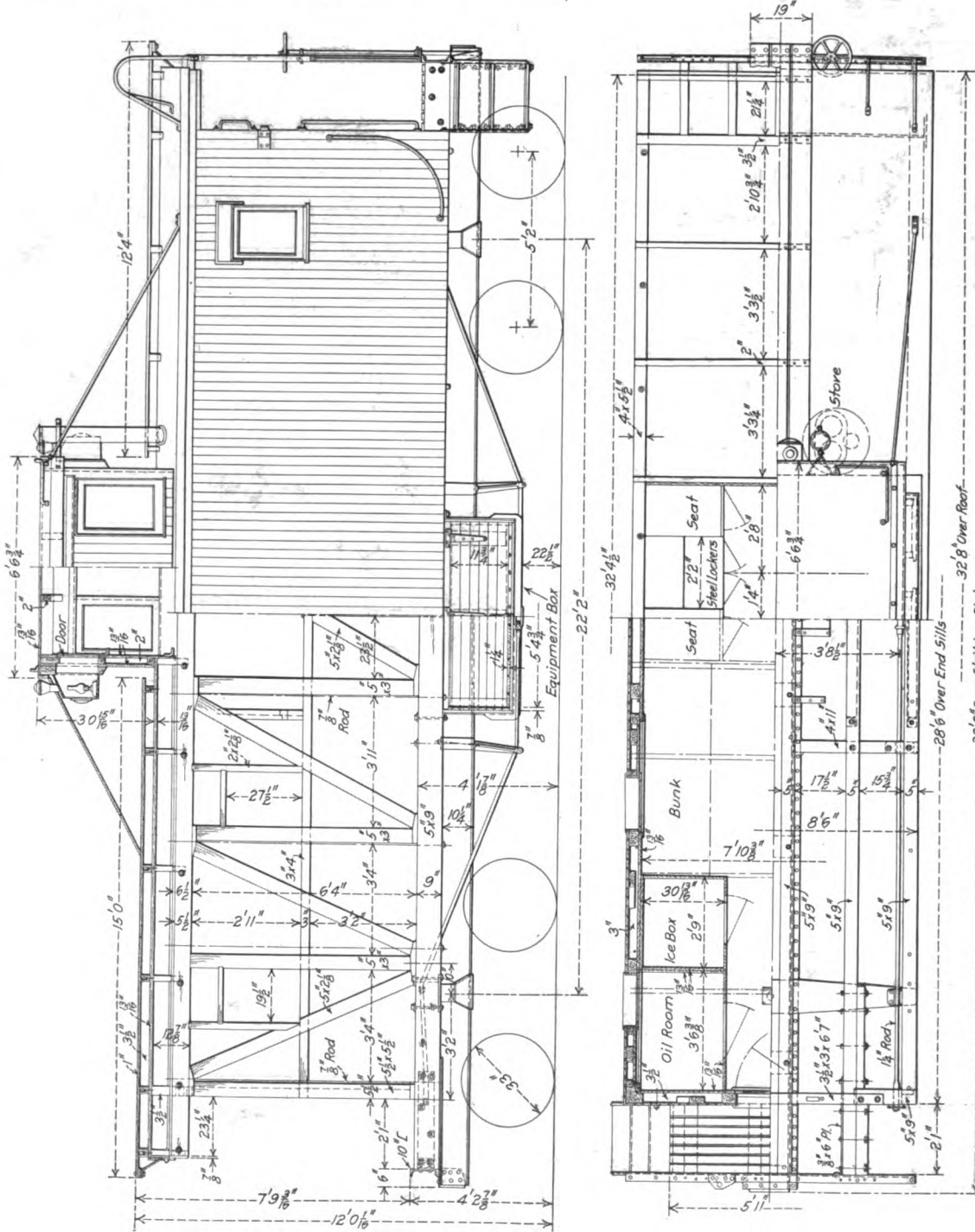
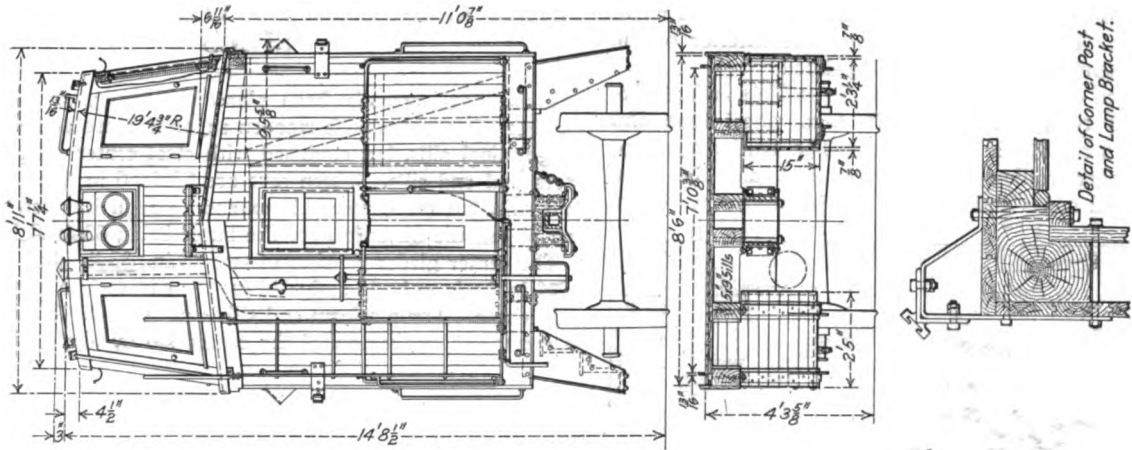

Elevations and Sections of the Erie Caboose with Steel Center and End Sills and Body Bolsters

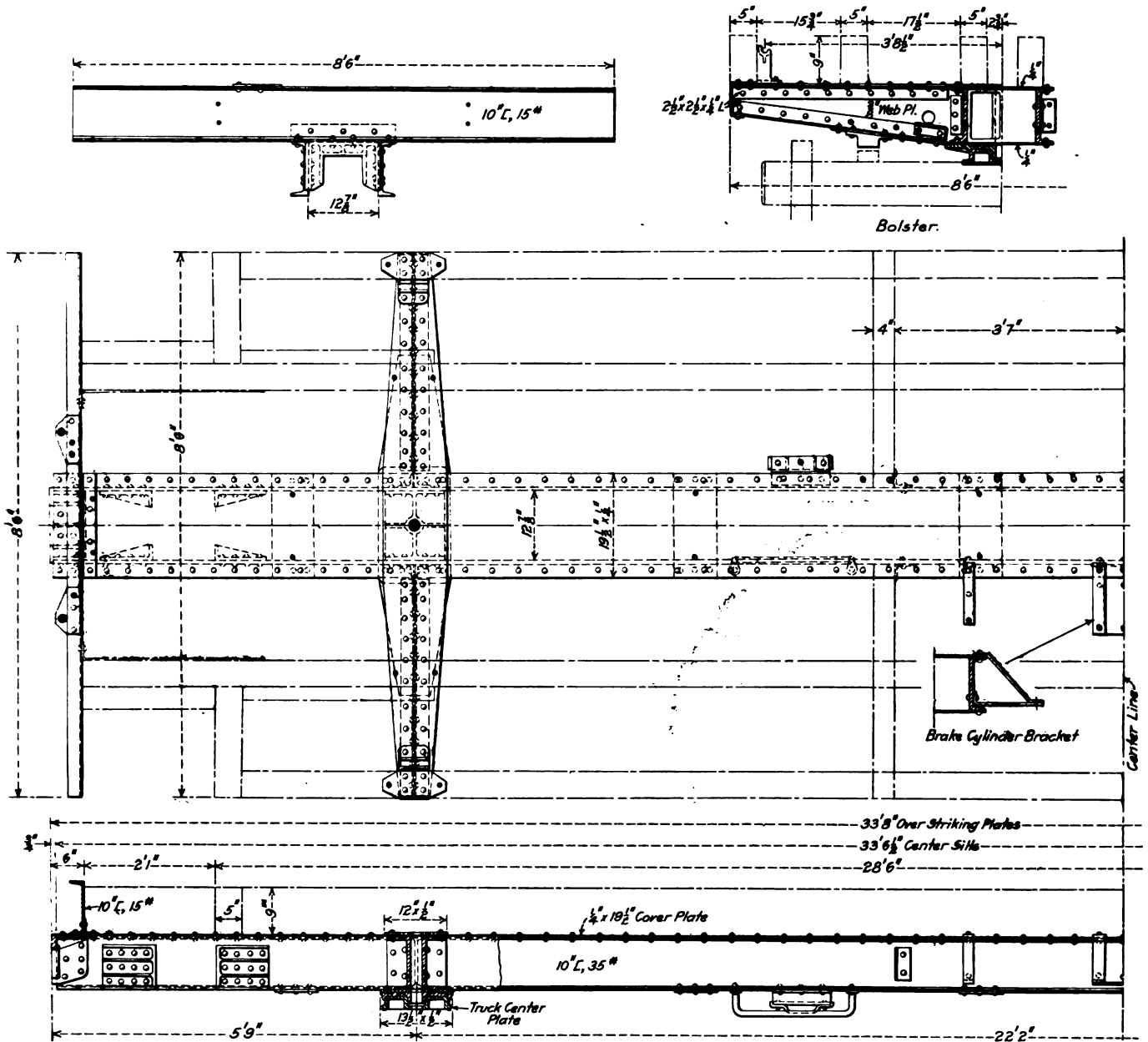

Arrangement of the Steel Members of the Caboose Underframe

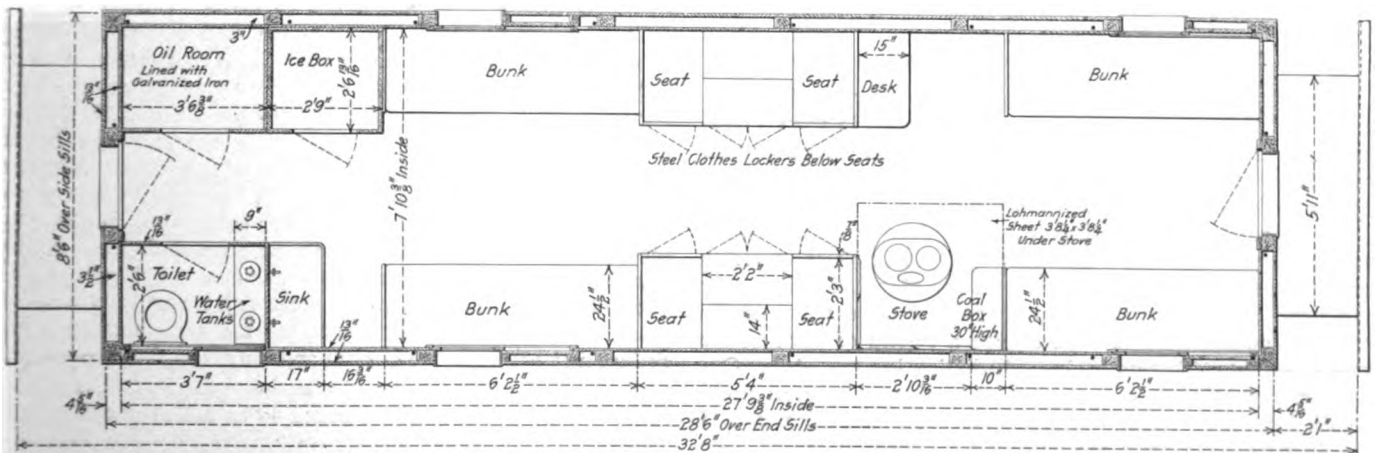

Floor Plan of the Erie Caboose

ter girder and body bolsters, while two truss rods, one on either side of the car at the outside, pass over wooden needle beams placed 3 ft. 7 in. on either side of the center line. The draft gear stops are riveted directly to the 10 in. channels which form the center sills. The wooden center and intermediate sills are carried through to the platform end sills, these extensions forming sills for the platform which is 2 ft. 1 in. wide. The steps are of steel construction with wooden treads.

The car is 32 ft. 8 in. long over the roof and 8 ft. 11 in. wide over the eaves. The cupola extends nearly the full width of the car at the base, tapering to a width of 7 ft. 7¼ in. over the

and the steel roofs whenever conditions warrant it. In most cases, no attention is given to the metal parts underneath a car, whereas they should be well protected.

Next in point of importance is the steel or semi-steel roofing. It is very important that this should be kept in first class condition in order to preserve it. The underside as well as the outside should be well painted when the car is being constructed, for the most deadly enemy to steel is moisture and there is no place where it is more apt to lurk than in the hidden parts of car construction.

One of the most expensive operations in painting cars is



Wooden Caboose with Steel Center Sills and Body Bolsters

eaves; it extends 6 ft. 6¼ in. lengthwise of the roof. The car is 14 ft. 8½ in. high over the cupola roof at the center. Special attention has been given to making the interior arrangement as comfortable and convenient as possible for the trainmen. The weight of the car is 38,700 lb.

RELATION OF THE PAINT SHOP TO THE REPAIR YARD*

BY WM. BUCHANAN

Foreman Painter, Delaware, Lackawanna & Western, East Buffalo, N. Y.

There is no money expended in the maintenance of railway equipment that gives more value than that used in protecting a car well with paint. On the steel car, rust and corrosion soon take place, caused from sulphur, dripping, etc., and the car becomes weakened and is a source of danger in transit.

On the road with which I am connected it is considered necessary to repaint steel cars once in three or four years, covering all portions of the car, and as far as my observation has gone the stenciling is always legible and most of the exterior of the car is in good condition. We employ a system of painting the cars in series, so that no haphazard painting is resorted to. Our wooden cars give a longer term of service. However, those which have steel underframes require closer checking and if we discover the frames are rusting we scrape and paint them

stenciling, and it should be done with a desire to convey as plainly as possible the information desired. First, the names and numbers of all cars should be in a uniform place, so that any one may know at all times just where to look for them. I am glad to say that a movement is at last under way to get the car owners to adopt a system of uniform standards of lettering.

The officers of some roads have advanced the idea that the painting of freight cars cannot be done during the winter months, especially in this climate and out of doors. During the year 1907, when we started the work at our East Buffalo shops, we painted, 1,413 cars. Nine cars were painted in January, three in February and two in March, so that we were practically at a standstill for three months. During 1909 we painted 2,198 cars; of these we painted 156 in January, 128 in February and 182 in March. In 1914 we painted over 3,000 cars, of which 177 were done in January, 158 in February, 165 in March and 122 in April. I think these figures show that we have been wrong in assuming that work of this nature could not be done during the winter months. Previously our year's total output was reduced, and we were obliged to lay off men of some experience who were of more value than new men, due to the fact that in working together, they become more efficient and can accomplish more work.

As most of the work done is in the open air, tracks should be assigned for this special purpose so as not to interfere with the repair men. The weighing of cars is no small item and should be entrusted to a reliable man who, after the cars are weighed, can put on the new weight, giving a report of the old

*From a paper read before the Niagara Frontier Car Men's Association, Buffalo, N. Y., December 16, 1914.

as well as the new weights so that the proper reports can be made.

The men who are assigned to look after the repair yard must at all times be on the alert, for whenever cars are undergoing repairs, more or less of the sheathing is ripped off, destroying the stenciled information which should be replaced before the car goes back into service. One item is wrong door numbers, due to the fact that an old door from some other car has been used instead of a new one. This is a source of confusion to those who are obliged to take numbers, as often the number is taken from the door instead of the side of the car.

The reclaiming of paint skins and settlings is an item that should be thoroughly looked after, for considerable money can very soon find its way to the scrap pile if the stock man is not watchful. He should also be responsible for tools and brushes

END CONSTRUCTION OF CANADIAN PACIFIC STOCK CARS

The fact that stock cars are used for many other kinds of freight, such as lumber, rails, ties, etc., seems to have been ignored by many designers and builders. As a matter of fact, if a careful check were made on some roads it would probably be found that stock cars are used for this class of traffic considerably more than for livestock. Even though the percentage of this traffic does not run high, the ends of stock cars will, on the average, receive more severe end shocks than box cars because, with the exception of rails or similar loads of steel, the majority of the materials loaded in them are piled high in the car and some of them, particularly pipe and pulpwood, are slippery, which causes them to produce heavy shocks; on the other

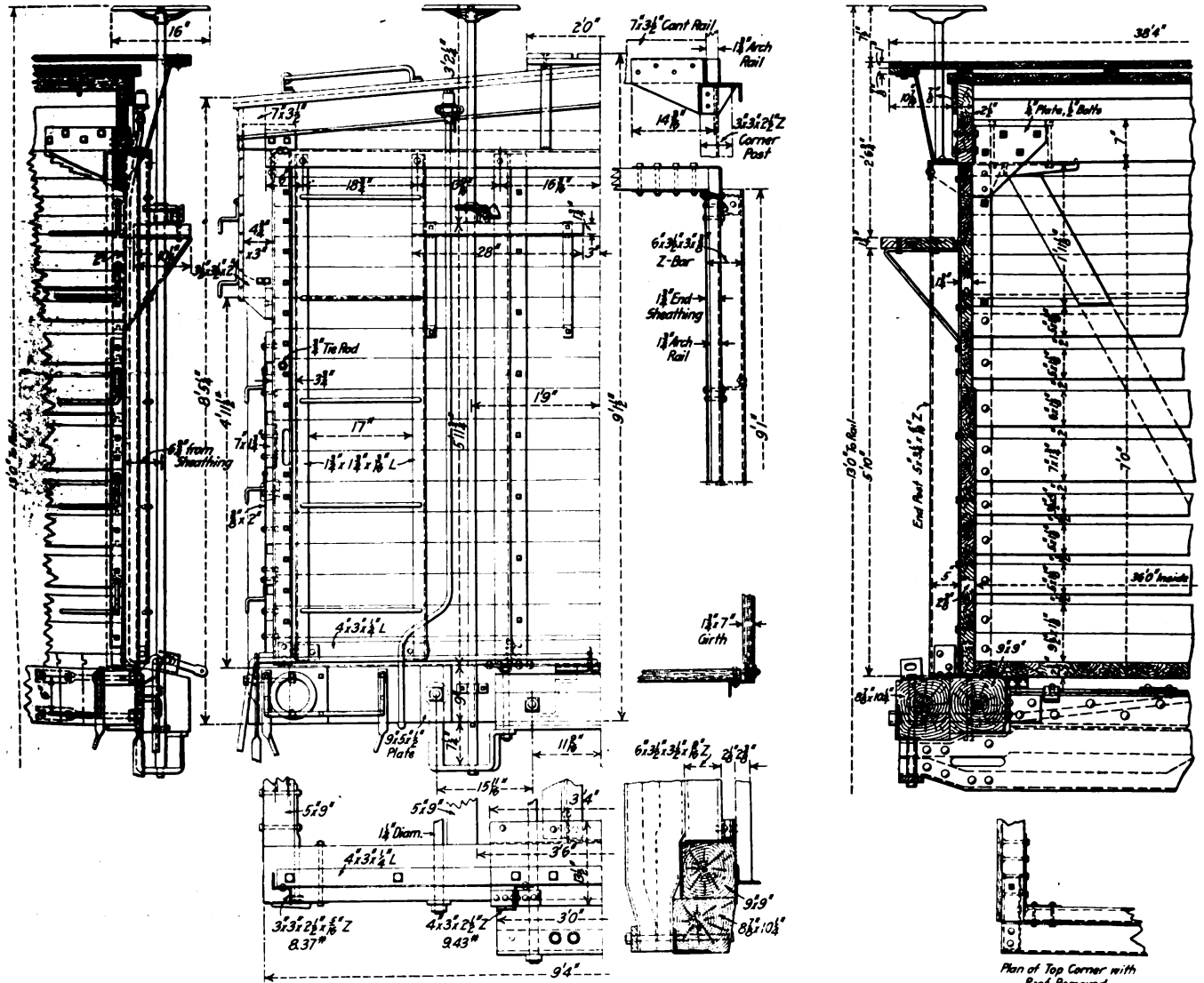

End Arrangement Used on Canadian Pacific Stock Cars

given out each day and see that they are returned at the end of the day's work and placed where they belong. A suitable building for the storage of oil and paints is essential as well as modern devices for mixing paint, and sanitary quarters should be provided for the workmen.

hand box cars, being used for a greater variety of lading, do not so frequently have a load of this description.

This condition is not taken care of in many designs, and for this reason the end arrangement of the latest type of car built by the Canadian Pacific may be of interest, as illustrating how a substantial end may be easily and economically applied to a car of otherwise standard construction. This car is a standard design that has given excellent service for some years, but the newer cars have been constructed with steel center sills in connection with reinforced ends to eliminate draft gear troubles.

The end construction consists of two 5 in. 11.6 lb. Z-bar end posts, heavy angle corner posts, a 5 in. 11.6 lb. Z-bar end plate

OXYGEN IN BLAST FURNACE PRACTICE.—If oxygen is added to the air-blast for a blast furnace, so that it is present to the extent of 23 per cent in the air instead of the normal 21 per cent, there is a saving of from 110 to 130 lb. in the amount of coke required to smelt a ton of iron, and the iron produced is said to be of a higher quality.—*Scientific American*.

securely attached to the end posts, and corner posts securely attached to the wooden side plates by means of gussets with several bolts through the timber. The lower ends of the end posts are connected to a sill plate passing over the top of the wooden end sill and riveted to the steel center sill, firmly uniting the center sill construction and the end framing. The end lining consists of $2\frac{3}{8}$ in. tongued and grooved pine or spruce for a height of 4 ft. above the flooring, with $1\frac{3}{4}$ in. thickness the balance of the height.

This construction produces a car that is economical in first cost and will satisfactorily withstand ordinary service conditions either for stock or other lading.

The last order of these cars was equipped with socket castings inside of the slats to support temporary decks. This temporary deck is so designed that if similar castings are applied, the same deck will be interchangeable in any 36 ft. car. When these castings are applied to a car, the sheathing board immediately below the fascia is removed to provide ventilation for lading carried on the upper deck.

JOINT CAR REPAIR SHOPS AT LARGE TERMINALS*

BY F. C. SCHULTZ

Chief Interchange Inspector, Chicago, Ill.

Joint repair shops should be established in districts in which a large number of industries are located, so that after bad order loaded cars arriving in these territories are unloaded, they can be repaired and reloaded. This avoids hauling the car back empty to the delivering line, and also creates a supply of good order cars for loading at industries in such districts. If such cars were repaired, it would also avoid the necessity of the hauling of a large number of empty cars into such districts for loading.

The available cars for such joint shops in Chicago, for example, would amount to about 250 cars per day, including both light and heavy repairs. In addition to the cars that accumulate in these territories, provision should also be made for forwarding to such shops, foreign bad order cars which accumulate in the terminals of railroads in the vicinity so as to entirely relieve the railroad companies' shops from the necessity of repairing foreign equipment. It is far more economical to carry such necessary foreign material as is needed at a joint shop than it is to carry a supply at each of the shops of the various railroads entering a large terminal.

The M. C. B. Rules which went into effect on October 1, 1914, and in particular rules 1, 2 and 120, have brought about the accumulation of a large number of foreign bad order cars; if such repairs were made at a joint shop, a great deal of the material removed from the cars which the car owner orders dismantled under rule 120 could be used when making repairs to foreign cars. If joint car shops were established, an organization should be created to supervise as follows:

First: To authorize repairs that are necessary by making an inspection of the cars.

Second: To see that the repairs are properly made.

Third: To see that bills are properly rendered for the work done.

One of the great advantages to be gained by having a joint car shop would be the creation of a car supply, thereby saving a large amount of money, both in intermediate switching charges and per diem which accumulates while such cars are being moved back and forth. The delay of moving such cars to repair tracks for repairs should also be considered.

To illustrate, if a car moving under load from one railroad to another via a switching line to an industry is found in bad order on unloading, it is returned to the switching line for delivery to the originating line where the repairs are finally made. A joint

car shop would reduce the switching and make the car available for loading more quickly, as well as reduce the liability of damage due to accident on account of handling bad order cars.

Another matter that would have to be looked into, would be the question of the proper amount to be allowed to the terminal line for switching charges to and from such shops. When a car is delivered to a switching line under load, a switching charge is made which carries with it the return of the empty car to the originating line. The movement of cars from industries, after they are unloaded, to the shops for repairs would be about the same as though the cars were returned to the originating line empty, and switching charges should only be allowed for the service of switching the car from such shops after the repairs had been completed. This, however, would not apply to cars delivered empty to such lines by railroad companies for repairs at such shops; in such cases separate rates should be made.

DEFECTIVE BOX CARS*

BY L. BROWN

The most important defects in box cars are those which cause a lack of thorough protection to lading. A box car is housed for the definite purpose of protecting freight against loss and damage and any car which is built for this purpose should be so designed that under ordinary wear and tear, with reasonable maintenance, all parts should combine to give thorough protection during the full life of the car. The box car has been developed and used on this continent much more than elsewhere and even today foreign countries are moving their freight largely in open-top cars covered only with waterproofed cloth.

The superstructure of a box car is an expensive article compared with that on a gondola car and much more is expected of it in the way of protection of lading. The defects which cause this lack of protection can usually be attributed to faulty design, poor workmanship, rough usage or lack of maintenance. Designers are, too frequently, not in close enough touch with the cars they have designed, and are working on new designs before the defects in the previous ones have been developed far enough, or discovered at all. This condition is more liable to occur when railroads want cars in a hurry, which is usually the way they want them. A car often shows weaknesses after several years of service which were not apparent when it was new. Much poor workmanship is caused by men working under the piecework system; under these conditions they will not waste a minute to make good a defect which can be hidden, and this frequently occurs when the system of inspection is lax. Rough usage is something for which the operating department is chiefly responsible, but the car designer, builder and repairer can each do their share to prevent its bad effects.

The most common defects which cause loss and damage are in roofs and doors. The remedy for these defects lies in eternal vigilance and a constant lookout should be kept for signs of weakness. Much good information can be obtained by inspecting cars in rainy weather and by watching cars traveling when loaded; by car designers getting in touch with operating conditions and obtaining information from those in a position to regularly observe cars in service and on repair tracks. Any part of a car should be of such a nature that with reasonable maintenance it will give satisfaction during the whole life of the car. Designs should be simple but efficient and a few dollars spent in careful designs may save many times as much money later. The railroads cannot spend money to better advantage than to see that the designs of their box cars are carefully made and thoroughly considered in the smallest details and, if necessary, thoroughly tested before the building of large numbers of cars.

*From a paper presented at the December meeting of the Car Foremen's Association of Chicago.

*Entered in the car department competition which closed October 15, 1914.

SHOP PRACTICE

HANDLING WORK REPORTS AT ENGINE HOUSES*

BY JESSE E. TEFFT,

Chief Clerk, Motive Power Department, New York Central & Hudson River,
Peekskill, N. Y.

The report of work required on locomotives at engine houses on one of the main line divisions of a large eastern railroad is handled with the use of three forms. That shown in Fig. 1 is

sary repairs made the book is also signed in the proper column by the workman who cares for this class of work. This renders it easy to place responsibility for failure of this equipment if such failure is due to neglect in maintenance or to the engineman not reporting the defects.

The form shown in Fig. 2 is in book form, containing either 150 or 300 pages, according to the size of the terminal where it is in use, and entries are made in black ink by the work report clerks from the dictation of the engineman on arrival. Each

Condition of Locomotives at end of trip, and of Air Brake Equipment before leaving terminal.										
Date <u>Buffalo 5/25 1914</u>										
Loco. No.	SAFETY VALVE		AIR PRESSURE		CONDITION OF				SIGNATURE OF ENGINEMAN	AIR BRAKE EQUIPMENT INSPECTED BY ME AND FOUND IN GOOD CONDITION BEFORE LOCO. LEFT THIS TERMINAL (To be signed by A. B. Insp.)
	Lifts at Lbs.	Seats at Lbs.	Reservoir Lbs.	Train Line Lbs.	INJECTORS		Gauge Cocks	Glass Water Gauge		
					Right	Left				
3000	200	195	120	110	Not O.K.	O.K.	O.K.	O.K.	James G. Brown	John Doe

Fig. 1—Form Showing Condition of Engine at End of Trip

used for reporting the condition of the locomotive at the end of the trip and of the air brake equipment when leaving the terminal. The form in Fig. 2 is used to indicate the condition of the locomotive at the end of the trip and that in Figs. 3 and 4 is the locomotive work card. The practice is uniform at each point on the division.

The form in Fig. 1 is in book form containing 150 or 300 pages, according to the size of the terminal at which it is used, and shows

item of work reported is shown separately and numbered in consecutive order, commencing with No. 1, for each locomotive. For example:

- Right injector does not prime.....No. 1
- Clean out tank wells.....No. 2
- Repack right trailer box or examine brass.....No. 3

The numbers of each item are shown in the column at the extreme right-hand side of the page.

Condition of Locomotives at end of Trip.			
Date <u>Buffalo 5/25 1914</u>			
Loco. No.	The Locomotive is in good condition, with following exceptions		Disposition of each item of work Reported
	(To be signed by ENGINEMAN and INSPECTOR)		
No. of forms M. P. 26 Issued for each Loco.			
3000	Right injector does not prime		1
	Clean out tank wells		1
	Repack right trailer box or examine brass		1
	James G. Brown		

Fig. 2—Form for Reporting Locomotive Repair Work

the condition of the air brake equipment, also of the injectors on locomotives arriving. Entries are made in black ink by the work report clerks from the dictation of the engineman who signs the book with his full name in ink before leaving the office, each item being marked "O. K." or "Not O. K." as the case may be. After the air brake equipment has been inspected and the neces-

It might be said here that a vigorous campaign of instruction is conducted by the road foremen and assistant road foremen of engines among the enginemen to educate them along the lines of rendering clear and concise reports covering the existing defects as nearly as possible. This means a saving in time for the engine house force as it relieves them of the necessity of searching for the cause of the trouble.

Each engineman signs his full name in ink under the items

*Entered in the competition on Engine House Work, which closed July 15, 1914.

reported by him on his locomotive. If an engineman has nothing to report his locomotive number is entered, and he signs the book over the words "No Defects." Any work not reported by the engineman, and found necessary by any of the inspectors, is also entered in this book in red ink by the clerk and signed for by the man making the report.

The small work slips shown in Figs. 3 and 4 then come into use. Work reported on the form in Fig. 2 is transcribed by the clerk to these slips, a separate slip for each item reported, the numbers of the slips corresponding with the numbers of the items shown in Fig. 2. The slips are distributed to the sub-

LOCOMOTIVE WORK CARD. No. 1		
Eng. No.	Eng'r or Insp.	Place and Date
3000	James J. Brown	Buffalo 5-25-14
Right Injector does not prime		
Above Work Performed by		Date
John L. Smith		5-25-14

Fig. 3—Work Report Slip

foremen by the engine house foreman, being given out according to the nature of the work, boiler work to the foreman boiler-maker, oiler's and dozer's slips to the head oiler, machine work to the gang foreman, etc. These foremen distribute the slips to the men who actually perform the work.

The work slips are divided into three classes, as follows:

- 1.—Includes all forms showing defects which were remedied before the engine was despatched.
- 2.—Includes all forms for repairs which in the judgment of the foreman are not necessary.
- 3.—Includes all forms covering defects that were not remedied before the engine was despatched.

First-class slips must be properly dated and signed with the

REMARKS—Why Not Done	Foreman
Lack of proper material - Engine head in	James L. Smith 5-25-16

Fig. 4—Reverse of Work Report Slip

full name of the workman who makes the repairs. Second-class slips are marked with the words "not necessary" by the engine house foreman, who signs and dates them across the face. Third-class slips must show on the back why the work was not done before the engine was despatched, over the engine house foreman's signature and the date of signing. As soon as each slip is completed it is deposited by the workman in a box provided for the purpose in the engine house. These slips are collected by a messenger and taken to the work report clerk who checks them off in the book, Fig. 2, as follows:

For first-class slips a figure 1 is placed opposite the item in

the column headed "Disposition of each item of work reported," Fig. 2. For second-class slips, a figure 2 is placed in the book, and for third-class slips a figure 3 is used.

After being thus checked off the slips are filed in a separate cabinet provided with two compartments for each locomotive number, a large one for first and second-class slips and a small one for third-class slips. This cabinet is shown in Fig. 5. This keeps the slips covering unfinished work separate, and they are again delivered to the workmen on each subsequent arrival of the locomotive until the work reported is completed, when the figure 3 in the book shown in Fig. 2 is circled and a figure 1 is placed opposite it, indicating that the repairs have been made. Slips covering work reported on engines going to the main shops, or sent for permanent assignment to some other point, are forwarded by mail to that point and after the work is done are returned, checked off, and filed away, thus making the record complete. Before the 15th of each month all first and second-class slips for the preceding month are removed and filed in packages properly listed, together with the completed books, Figs. 1 and 2, for further reference.

It will be noted that a perusal of the book shown in Fig. 2 will show just what was done with each item reported, and while

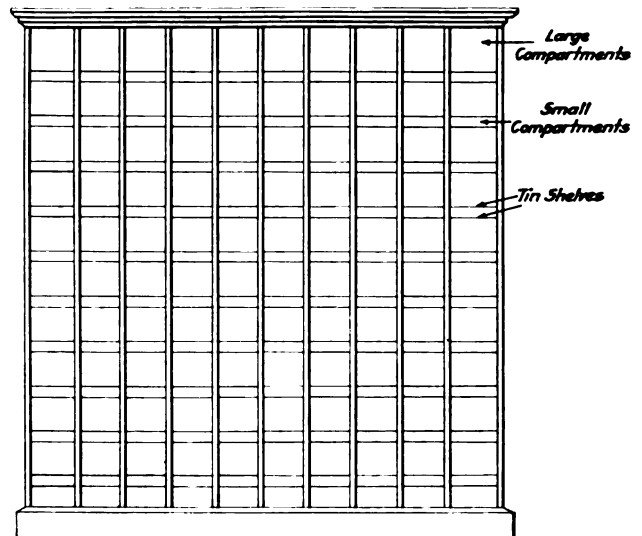

Fig. 5—Work Report Filing Cabinet

it may seem that this system is too intricate for practical purposes, actual practice proves that such is not the case, as it has been in use for three years with very good results. With this method it can be very quickly determined just what work was reported on any locomotive by referring to Fig. 2 and then from the number of the slip listed therein, the work slips can easily be located from which the signature of the workman who made the repairs and the date they were made can be obtained. The fact that such an absolute record is possible with this system has a tendency to make the workmen more careful as they know that they can be closely checked up for each item of work done. The form shown in Fig. 2 also furnishes a rapid and accurate means of determining the number of arrivals and the number of engines repaired at a given point for any period desired, which is something that required a great deal of time to complete before this system was inaugurated. The cost of installing this system is not great, because, except at large terminals where a great many engines are handled, the system can be taken care of by the regular engine house clerks in addition to their other duties.

TOOL MAKERS.—Until a manufacturer reaches the stage where he can employ steadily the minimum number of tool makers, a toolroom is a rather expensive proposition.—*American Machinist.*

RIVETING IN STEEL CAR CONSTRUCTION

A Brief Discussion of Rivet Manufacture; Operations Which Are Necessary to Secure Tight Rivets

BY H. A. HATFIELD

General Foreman, Canadian Car and Foundry Company, Montreal Que.

I

One of the prime factors upon which the strength of a steel car depends is the riveting and its appearance may be permanently marred by careless workmanship or the use of improper tools. Tight rivets of uniform shape and size, without collars or marked plates, can only be had by studying the details of every operation in the history of the rivet. This history begins with the ordering of the stock and includes the arrangements made for storing it from the time it is rolled till the rivets are driven as well as the operations of manufacturing and driving.

THE RIVET

Stock for rivets should be purchased to specifications and carefully checked by the purchaser's inspector. Particular attention should be paid to the diameter of the bars as a very small variation over size will make them too large to go through the dies without leaving heavy fins on both sides of the shank of the rivet, while if the stock is undersize, the dies will not grip it and the header will shove it back instead of upsetting it. Rivet material should be stored in a dry place under cover, and should be stocked in small quantities in order that it may be used before being damaged by rusting. The rust comes off in

in heading stock that has rusted very badly because it will be under size and the dies cannot grip it. There will also be trouble in driving, due to a lack of material to make a full head; and because of the weakened cross section, pitted stock has a tendency to bend rather than to upset. For the same reason the supply of rivets kept on hand should be small. Open rivet bins collect a great deal of dust and this, together with moisture, stray electric currents, and the gases in the shop, is the source of rapid corrosion.

Broken rivets, though generally attributable to poor material, are sometimes the result of improper heating of the rivet stock. Very few machine hands really know how to heat, and tend to get too much material into the furnace at one time. Before it is worked up the last few bars have soaked so long that the metal will be soft and spongy. Rivets made from such metal have a very crystalline structure and are very brittle when cold. This should be explained to all operators and they should be particularly warned to shut down the furnace when delays occur for slight repairs, etc. Another prevalent practice is to make rivets before the stock is heated hot enough to flow properly, and as a result the edge of the rivet head is cracked all around. The reason neither of these conditions causes very much trouble lies in the fact that the heating for driving really acts as heat treatment for metal not too greatly changed in structure, the hammering completing the cure. Those previously heated to excess waste so rapidly that they are scrapped.

If the volume of work justifies it, the best and cheapest method of handling the stock and product is to install an electric crane, though provision should be made for handling by hand in event of any accident to this equipment. It may also be handled by means of an industrial railway and an elevator for lifting the trucks to the top of the bins. This method takes more labor for handling purposes and considerable floor space that with the crane system can be utilized for other purposes. Whatever system is used the boxes can be arranged close enough to the machine for the rivets to fall directly into them, and save the time and labor necessary for shoveling. A small jib crane near the machine may be used to lift the boxes and to change dies.

In choosing a heading machine a multiplicity of parts is to be avoided; the die gripping mechanism should be positive and the attachments easy to adjust. The output may be seriously affected by the time required to change dies after the machine has been used for some time because of the time lost in packing out dies and otherwise trying to correct the wear on the slides. No amount of packing will compensate for worn slides. The rivet heads may be off center owing to the header rising or swerving to one side, or the shanks out of true because of the lost motion in the gripping slides. For these reasons the machine chosen should be designed with some arrangement enabling accurate alinement to be maintained. It is preferable that scale and water should not fall on the slides, as this is the cause of a greater part of the wear.

Rivet machine dies should be made of a good alloy steel ordered specially for this purpose. Carbon steel may serve for rivets made in small quantities, but for long runs on the larger sizes the edges of the passes will fail, the temper being drawn by the hot work. Such a pair of dies will outlast several pairs of carbon steel and repay the higher first cost not only in replacement, but in machine time saved and in the quality of the output.

Unless special precautions are taken, some difficulty may be



Rivet Heading Machine with Overhead Crane and Storage Bins in the Background

the dies, making it impossible to produce clean rivets from very old stock. It also spoils the bottom of the furnace. Poorly made steel rushed through the various operations in manufacture and steel made by rerolling or "bushelling" scrap are particularly liable to corrosion and pitting. If the bars are very badly pitted, the shanks of the rivets made from it will appear to have been overheated, and they may be scrapped as burnt by the heater boys in the riveting gangs. Difficulty will be found

had in getting the two dies to line up in the machine owing to the variation in the distance from the center of the passes to the face resting on the slide. A method which prevents such trouble is to clamp the two die blocks together and machine them up square, then put them on a surface plate and lay off the center of the passes from the plate, so that this important dimension is always the same. The most economical dies are made with two passes on the side; if only a small number of rivets are required of one diameter and length, the bore of the different passes need not be the same. Worn dies can be redrilled for rivets of a larger diameter, and they may be planed down for shorter lengths as the ends of the passes wear. The bore of the pass is material size, it being the usual practice to roll rivet stock 1/64 in. below size, the expansion due to heating being sufficient to hold the stock under the impact of the header after it has been cut off from the bar. The sharp edge should be taken off the end of the pass next the header to leave a small fillet between the head and shank of the rivet. Different makes of machines require different sizes of die blocks, but the length of the pass equals the length of the rivet plus 1/16 in.

With the exception of the shank the header must be hardened or it will upset, bend or break. Great care should be taken when setting the dies that the header is not off center, as a lop-sided head detracts greatly from the strength and appearance of the rivet. The size of the cup should be gaged frequently, as a worn cup will make big heads and ragged riveting will result.

Every shop has its own standard proportions for rivet heads, and it is unusual to find any two agreeing exactly in size. After a company has tried and adopted certain standard sizes, however, they should be firmly adhered to. A complete set of master gages should be made and kept with the shop records and duplicate sets for machine shop use placed in the tool room. Every department foreman concerned should have a male gage for all the sizes in general use, so that he may know that his tools are in good condition. That the strength of the work, especially single riveted joints, is increased by any addition to the weight of the rivet head is true; but it is not advisable to go beyond the usual sizes given in the hand books on structural steel, as the increased strength is obtained at an increased cost for rivet stock, the output from each riveter is decreased, owing to the trouble in keeping the greater lengths from bending in the machine, and a greater number of rivets are driven loose because of the increased difficulty in getting the shanks to upset in the hole. On the other hand the

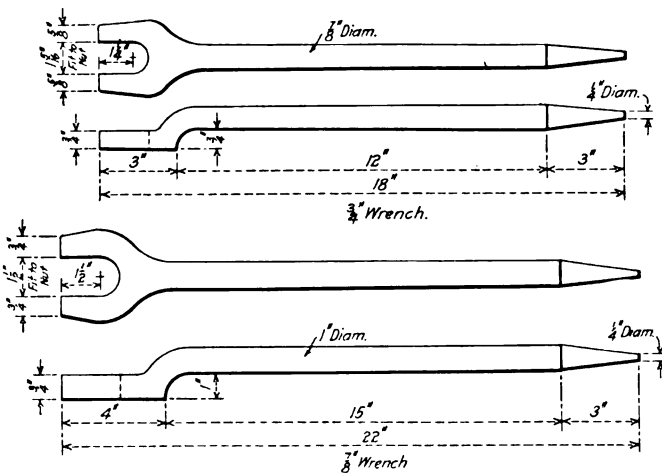

Wrenches for Use in Assembling Steel Cars

head should not be made too shallow as it is liable to snap off in tension, nor should it be spread so that the diameter is out of proportion to the height, or the material be distorted in forming.

ASSEMBLING

Granting that the forming is well done and the punching is accurate so that the holes match well, it is of the greatest im-

portance that all parts be bolted together so closely that the rivet cannot spread and form a collar between them which will hold the two surfaces apart. All work should be lined up by means of gages and straight edges and bolted so solidly that the reaming will not disturb it. Wrenches for assembling should be made similar to those shown in the engraving, the pointed ends serving as pins which may be used to pull the parts into line. The handle may seem long but as it is positively necessary to have the parts of the work drawn close together, short handles should only be used when space does not permit the use of long ones. Medium weight sledges with smooth faces and no sharp edges to mark the work may be used to drive the parts to place. Benches or trestles for assembling purposes should be strongly made. A light rail spiked to the top will facilitate handling heavy work. Jigs for the sides, ends, etc., should be of heavy construction so that they will retain their accuracy under rough handling.

All work should be assembled with bolts the same size as the rivets to be driven; punching not allowing for this should

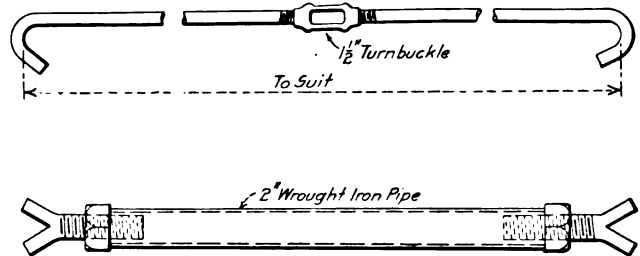

Brace and Clamp for Use in Assembling Steel Cars

not be accepted. Bolts with special coarse threads should be made for assembling, 7 threads per inch for 5/8 in. bolts and 6 threads per inch for 3/4 in. bolts. The standard thread wears too rapidly for this work and the bolts cannot be rethreaded as many times, nor can they be tightened up as quickly. Washers for assembling may be made cheaply from scrap of various thicknesses. Nuts that are too big to be retapped are suitable if used with a plate washer next the work. The supply of bolts should be plentiful and include a number of lengths as it is often necessary, in case of a projecting flange or two bolts coming close together, to use a long bolt and a number of washers in order to get the nut in such a position that the wrench can be used to advantage. Numerous attempts have been made to get away from the bolt and nut as a means of fastening, and various kinds of clamps tried, but those found powerful enough to close up the work are expensive to make in the quantities required.

Drift pins are best made of a good tough steel high enough in carbon to make them stiff but not enough for them to fly under the impact of the sledge. Old reamers or dies drawn down are dangerous for this reason. Braces should be made of 1 1/4 in. round stock, the threaded end being upset for a 1 1/2 in. turnbuckle. Spreaders may be made of pieces of pipe in which a fork threaded to the head, with one nut on it, is inserted. Jacks of various sizes and kinds, a number of strong clamps and several chains of different sizes complete the assembler's outfit.

REAMING

It is quite usual to find the reaming handled by the least intelligent men in the shop, for the air motor is heavy and the work monotonous, but no man should run one of these machines until he has had its principles explained to him and he knows enough to see that it is properly taken care of. It is good practice to use one make and size of machine throughout the shop, since then it is only necessary to keep one type of repair parts on hand and all tools are interchangeable. The non-reversible motor is preferable because it is impossible to run the tool in the wrong direction, and the power may be cut off positively

in case of accident. A good air machine weighs about 50 lb., and uses from 30 to 40 cu. ft. of free air per minute at 80 lb. pressure. The work of reaming is carried on under conditions that are far harder on the machine than any drilling within its capacity. Unfortunately it appears that these machines are developed for conditions favorable to drilling; the higher speeds, heavier cuts and lack of positive support—conditions that must be met in reaming—greatly increase the repair bills and necessitate more than ordinary care to keep the machines always in first class order. The prime requirement is to keep them well oiled. There are several makes of grease for use in air motors. Each machine should be partly filled at intervals and one man should be detailed to oil every machine at least once a day.

For car work it is cheaper to make reamer tools than to buy them. Extreme accuracy not being called for, they may be 1/64 in. over size to allow for grinding. The shanks for all sizes should be made for No. 3 Morse taper sockets. By this practice the larger sizes may be recut for the smaller sizes without touching the shanks, and it is necessary to remove the socket from the machine only when replacing it by a new one. Care should be taken with the tang and taper, since a bad fitting tool means time lost in the shop trying to get it to stay in the machine. If the tool is loose in the socket it may drop partly out when the machine is started, break the corner off the tang and spoil the socket; for this reason it is best that all sockets and shanks should be fitted to standard gages and that worn sockets be scrapped. A drift pin should be provided for removing the tools from the socket. The sockets should always be removed from the machine by the last turn of the feed screw, or by a hardened steel rod which is passed through the spindle after the feed screw has been removed. Reamers should be made of high speed steel, as in most cases it is impossible to have water at hand for cooling purposes, and carbon reamers burn up unless water cooled.

It has proved the best practice to use 3/4 in. air hose, and as flexibility is not of as great importance as with the riveting hammers, the heaviest kind of armored hose will be found the cheapest for this work; 1/2 in. hose connections should be used for all pneumatic tools.

The following facts should be impressed upon the reamer operator: That a reamer is a high priced machine, not to be subjected to unnecessarily rough usage; that the parts operate at a high speed under pressure, and unless plentifully supplied with lubricant, the cost for repairs and lost time will be heavy; that there is a critical speed at which the tool works best which is very near the stalling point; that drilling is a different proposition from reaming, the drill being run with the lowest possible speed and the greatest feed up to the stalling point.

The development of the electric drill has been so rapid that it is only a question of time before it replaces the air machine. It is cheaper to install, and costs less for upkeep. There is practically no loss from leakage and no drop in pressure, two things greatly against the air machine; nor do changes of weather and temperature affect it. It has been stated that drilling with compressed air is approximately two to three times more expensive than with electrically operated drills, and the same holds goods for reaming. The two great reasons for not installing electric reamers are the fact that it is still necessary to use air to drive the rivets and that the machines operated by alternating current are not as successful as those using direct current. Since alternating current is largely used for power, the use of direct current accessories would require the installation of a converter set and special wiring.

MACHINE RIVETING

Rivets can be driven by a pneumatic riveter at a lower cost than by a hydraulic riveter or a pneumatic hammer. Space in the present article is not available to do more than state the fact, but it amounts to about 25 per cent saving over the hy-

draulic machine and nearly 50 per cent over the pneumatic hammer. In addition the rivets are tighter because the toggle effects a gradual application of the pressure which constantly increases as the stroke advances and the shank of the rivet is upset so that it completely fills the hole. It is therefore seen that any work which can be handled to a machine or on which a portable riveter can be employed, should be machine riveted.

There are a number of makers with both stationary and portable riveters on the market, several different types of which are designed especially for car shop purposes. When buying this equipment it is a mistake to get larger sizes than the greater part of the work calls for. The majority of the rivets used being 3/8 in. and 3/4 in., machines to drive these sizes and no larger should be purchased. An inch increase in the diameter of the piston and an inch or two added to the length of the stroke may greatly increase the number of cubic feet of air used. This is decidedly expensive, for according to Hiscox a two stage compressor under the best conditions develops 14.5 hp. in compressing 100 cu. ft. of free air per minute to 90 lb. pressure. This means that a machine using 5 cu. ft. of free air per rivet, driving 20 rivets per minute, allowing for leaks the uses 16 hp. Since a little over half this volume of air at this pressure is required to drive a 3/4 in. rivet it is obvious that the best policy is to buy only enough large machines to take care of the rivets in the draft gear, the draw bar yokes, and the few other large rivets that may be required. Unnecessarily large riveters also mean further expense for increased compressor and receiver capacity.

Professors Unwin and Kennedy in a series of tests made in 1881-1885 proved that the shearing resistance of rivets is not highest in joints riveted by means of the greatest pressure and the ultimate strength of joints is not affected to an appreciable extent by the mode of riveting. Very great pressure in riveting is therefore not the indispensable requirement that it is sometimes supposed to be. Further tests proved that if the thickness of the material which the rivet passes through does not exceed the diameter of the rivet plus 1/8 in., and the rivet is hot, 15 tons pressure will thoroughly fill the hole and make a good 3/4 in. rivet. As the plate thickness increases, the pressure required increases approximately in proportion to the square root of the increase of thickness. That is, if the total thickness of plate is four times the diameter of the rivet we should require twice the pressure given above in order to thoroughly fill the hole and do good work. It is possible to use so high a pressure as to seriously injure the work. The plates are bruised and bent, and the holes may be subjected to a radial pressure sufficiently great to develop cracks in any but the very best plate. This condition is further aggravated, especially on thin stock, by the heat conveyed to it from the rivet and hot die. Stresses are set up between the hot and cold parts of the plate, a temperature is developed corresponding to a blue heat resulting in brittleness and the development of cracks later on. Most manufacturers issue a double warning with their machine and in their advertising matter. While they point out the impossibility of driving good rivets without an ample supply of air at the right pressure, they try to impress the user with the fact that the pressure cannot be allowed to run above that for which the machines are designed without injury to the machine and the work. Designs are usually based on 150,000 lb. per sq. in. as the pressure necessary to drive rivets. This is the highest value for the crushing strength of cold rivet steel. The real value seldom exceeds 100,000 lb. per sq. in., and it has been proved by actual tests that it takes only one-fourth the pressure to drive a hot rivet that is required to drive a cold one. Therefore the manufacturer's rating is very high and the smaller machines will safely take care of the riveting through any thickness of plate used in steel car construction. In this connection the economy of properly heating the rivets should be noted. It saves the machine, saves air and results in far better work.

The operator of a machine riveter is responsible for the ma-

chine and for the work turned out. Before driving any rivets, he should blow out any water that may have condensed in the cylinder and adjust his dies. This is done by letting the ram down and turning the screw till the die presses against the work. The ram should then be raised and the screw given a half turn down. In driving rivets the die should be brought down slowly at first until the ram is nearly out before putting on the full power. A sufficient number of dies should be kept at each machine to allow them to be changed frequently in order to prevent them from spreading, due to the continued heating. They may be paired, a long one with a short one, gradually decreasing one length and increasing the other in such a manner that the space between the dies will remain practically constant and the greatest possible amount of work will be obtained from the steel. By this method a die may be used till its thickness is little more than the height of the rivet head. Special die steel is made by some manufacturers for use without hardening and tempering. Where hardened dies are used the heat soon draws the edge of the cups, and it is necessary to anneal them before they can be recupped. A test is advisable before a selection is made, since there is a wide variation in the number of rivets which can be obtained without recupping.

SIMPLE FURNACE FOR MELTING BRASS

BY R. F. CALVERT

The illustration shows a design of furnace suitable for melting small or medium quantities of brass, which has been used satisfactorily at the Horton, Kan., shops of the Rock Island Lines. With the furnace one-half to two-thirds full it is possible to melt brass in about 30 minutes.

The shell of the furnace, which is 1 in. thick, is made from two hemispherical castings about 24 in. in diameter. The upper casting has an opening in the top for pouring, about 8 in. in diameter, and another opening, a little to one side, for the burner. The castings are lined with a 2 in. layer of fire-brick and the brick is

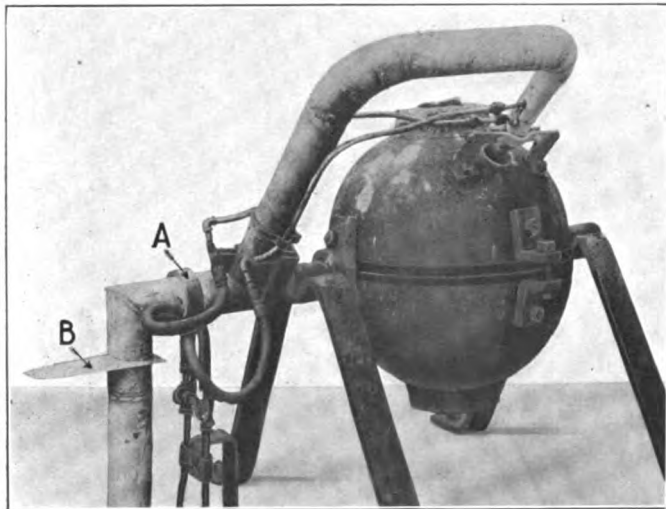

Furnace for Melting Small Quantities of Brass

lined with a 1 in. layer of fire-clay, except at the two openings. They are then clamped together by means of four lugs and 1 in. bolts. Two of these lugs are formed to act as bearings. They are 3 in. in diameter and are supported by a 4 in. x 1 in. wrought iron frame. Fastened to the outer end of one of these bearings are three wrought iron handles which are used for turning the furnace when pouring. The burner is supplied with a 2 in. blast pipe which has an oscillating joint shown at A. This blast pipe also has a slide for regulating the blast, which is shown at B.

The burner consists of a 2 in. blast pipe in which are located two other pipes, one for compressed air and one for oil. The

compressed air passes through a 1/2-in. pipe which enters the blast pipe about 4 in. from the nozzle and terminates about 1/8 in. back of the nozzle. The oil pipe enters the blast pipe about 6 in. from the nozzle and terminates inside the compressed air pipe at a point 1/8 in. from its end.

The supply of air and oil is regulated by valves located as shown. Both the compressed air and oil pipes are connected with about 4 ft. of hose which allows the furnace to be turned when emptying. The nozzle of the burner is about 2 in. from the outside of the shell and is formed by reducing the end of the blast pipe to 1/4 in. in diameter. The nozzle is supported by a wrought iron brace bolted to the shell of furnace.

BELL YOKE BEARING REAMERS

BY F. W. BENTLEY, Jr.

There is nothing in connection with the performance of the bell ringer that has more influence on its action than the condition of the yoke bearings of the bell. The necessity in most shops of removing the bell stand and reaming it on a drilling machine for correct alinement makes this a piece of repair work that is very often slighted, with resultant inconvenience to the enginemen.

The accompanying drawings illustrate a simply constructed set of reamers which make this a comparatively short piece of work. The reamer in Fig. 1 is for truing up the holes to 1 1/2 in.; the

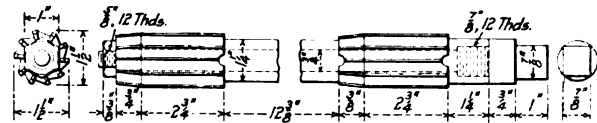

Fig. 1.

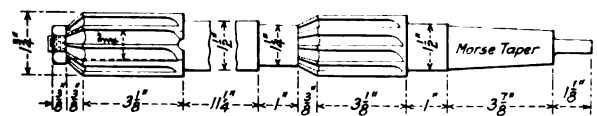

Fig. 2.

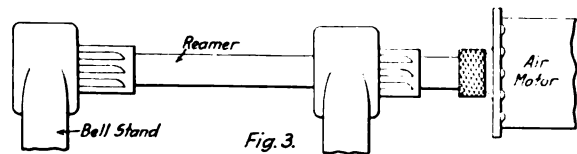

Fig. 3.

Reamers for Truing Bell Yoke Bearings

reamer in Fig. 2 is for reaming the holes when worn over 1 1/2 in. In either case a bushing is then applied to the wings of the stand to take the standard 1 1/4 in. yoke pin. Both reamers can be used in connection with an air motor and the operation is shown in Fig. 3. Owing to the double nature of the reaming cutters it is quite easy to keep the holes in line. The reamers eliminate all necessity of removing the stand and on one or two jobs of this kind will effect enough saving to pay for themselves.

This method of truing bell yoke bearings has been developed by W. H. Halsey, general foreman, locomotive department, Chicago & North Western, Missouri Valley, Iowa.

LINE LOSS.—Conditions may readily occur in connection with electric wiring where the drop may not be sufficient to cause any difficulty in the operation of lamps or motors, but if the loss over these wires is figured, it will be found advisable to use larger wire, as the interest on the increased cost of the wire will be less than the loss of power by the use of the smaller wire.—Power.

FORGING MACHINE DIES

BY J. LEE

The set of dies for a 1½ in. Ajax forging machine, shown in the drawing, has a number of small blocks of tool steel let into the main dies. These are of standard sizes to provide for interchangeability, and many jobs of a similar nature may be handled with the same main die blocks by changing the smaller blocks. This practice materially cuts down die costs.

The dies illustrated are for the manufacture of lazy cock stud handles and brake release handles. These are both made from ¾ in. round stock, cut to length in a shear. In forming the lazy cock handle one end is first upset, the stock is then put through the hole in the lazy cock stud and the other end is upset in the same die, as shown at section DD. This is done in one heat, and when necessary the balls can be trimmed up in the swedging die, section BB, to take off any fins. The brake release handles are first upset on one end with the die at section DD and are then flattened as shown at section CC. The punching die for these handles is shown at AA, the die block being drilled and a pipe let into the side to take away punchings. These three operations

LOCOMOTIVE RUNNING REPAIRS*

BY ERNEST CORDEAL†

It would be a task of no great difficulty to provide motive power of the highest possible efficiency for the movement of all trains, if no limit were placed upon the number of locomotives owned, if unlimited amounts of money were available for making repairs, and if shop and engine house facilities were kept up to the highest state of perfection. Such favorable conditions do not exist, and if they did would not be conducive to moderate operating costs.

Ultimate economy of operation, so far as the locomotive contributes, demands:

- (1) That the number of engines owned be no greater than is necessary to handle the peak load of traffic.
- (2) That shop facilities be sufficient to complete the necessary general overhauling without the consumption of excessive time in or awaiting shop.
- (3) That engine house work be so planned and conducted that locomotives are available for service the maximum number of hours per day and days per month, and that their condition be

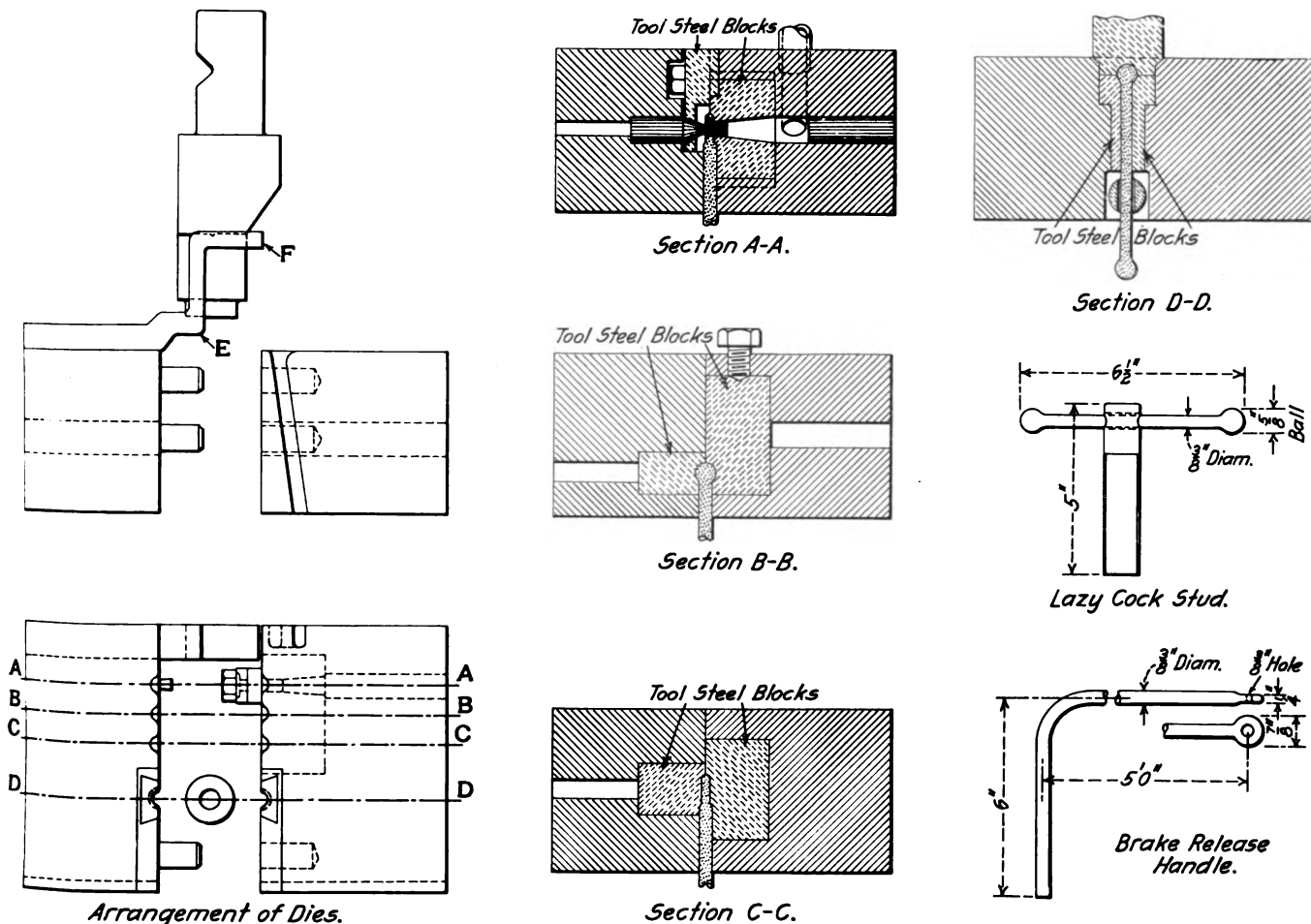

Forging Machine Dies with Insets of Tool Steel

are done in one heat. The other end of this handle has a right angle bend. To accomplish this a slot is cut in the top of the stationary die and a bracket is bolted on the side of the moving die. The bracket serves as both gage and bending tool, the part at E being the gage and the part at F doing the bending, the latter being done cold.

SPECIAL TOOLS.—The making and maintenance of special tools and fixtures are costly, and in order to put the toolroom on a satisfactory basis, system is an essential.—*American Machinist.*

such as to permit of handling the proper train loads without delays.

The failure to fully realize the third condition makes impossible the fulfillment of the first two. Where running repairs are not properly made, rapid deterioration of the machine must follow. Short periods between general shoppings result. The increased number of shoppings necessarily overloads the main

*Entered in the competition on Engine House Work, which closed July 15, 1914.

†310 Frisco Building, Springfield, Mo.

shops and leads to a poorer quality of general repairs, excessive time in the shop, and long periods of waiting on the hospital track. The purchase of new power is the usual expedient to relieve such a condition.

Again, inadequate running repairs mean low power efficiency. Locomotives will not handle their full tonnage; delays and failures are unavoidable; in order that the traffic may be handled there must be an excess of power. The failure, therefore, to provide for the proper maintenance of locomotives in service is responsible for excessive investment in power; high cost of shop repairs; inefficiency and heavy expense in train operation.

That a high cost of repairs per unit of work performed by locomotives insures the best power condition by no means follows. The contrary is in fact more often the case. The railroads in the United States which handle the greatest amount of traffic with the least investment in equipment, with the lowest train mile costs, with the fewest engine failures, have without exception a moderate unit cost of repairs, while many of those roads which expend unusual amounts in the maintenance of equipment, obtain a low mileage per locomotive per year, have a train tonnage less than the efficient minimum and register frequent delays from power failures.

The condition of power does not necessarily depend upon the amount of money expended in its repair. It does depend upon the time at which the necessary repairs are made. A man might comfortably sustain life with an expenditure of five dollars a week for food and lodging, provided he distributed the amount equally over the period. If, however, he gorged himself to the full extent of his allowance at the first meal he might starve or die of exposure before the next installment was due.

The quality of running repairs, paradoxical as it may seem, depends very little upon the adequacy of the engine house facilities provided. Up-to-date buildings, machinery and appurtenances are a convenience but not an absolute necessity in the proper maintenance of locomotives. It appears at times as though the mere presence of improved facilities for performing the heavier class of repairs leads to a neglect of the minor items. To maintain power in the best condition demands frequent and rigid inspection, and immediate attention to minor defects. If these two requirements are fulfilled, elaborate and expensive engine house layouts will be unnecessary. It is the shoe or wedge not properly adjusted that calls in time for the dropping of wheels to renew driving brasses and turn journals. It is the loose rod key that makes necessary the renewal of a back end brass; the broken follower bolt that knocks out the cylinder head; loose or ill-fitted bolts that break the frame, and the careless use of the beading tool which makes necessary the renewal of tubes. The detection of minor defects and their immediate correction is the whole secret of high power efficiency and low maintenance costs. The usual tendency of engine house forces is to overlook or pass over those minor items of repairs which do not materially interfere with the operation of the locomotive, postponing their performance until such time as defects of a serious nature have resulted. The cost of reducing a brass or setting up a wedge is insignificant as compared with the cost of renewing the brass, and perhaps turning a cut pin, or of dropping the wheels and renewing a driving box brass. The engineer, the engine inspector and the wiper are the agents of inspection. If they are competent, well trained and conscientious the greater number of the small defects, the neglect of which leads to failures and expensive repairs, will be found and reported before they have developed to a serious stage.

The engineer's report should cover such defects as develop during the operation of the engine, and should be made during the progress of the trip and not after arrival at the terminal. For this purpose he should be provided with a work report book of convenient size and shape to be carried in the pocket, so that he may make note of any irregularities which occur in the running of the engine. Many minor defects in the working parts of the locomotive are called to the attention of the engineer

while the engine is in motion. If note is not made of such imperfections at the time their presence becomes known they are very likely to be forgotten or overlooked when hurried entries are being made in the engine house work book at the end of the trip.

The engineer should not be expected to make an exhaustive examination of the locomotive after arrival at the terminal. In the first place, he is very infrequently a skilled mechanic and is not, therefore, qualified to make a competent inspection. Again, few engineers at the end of a trip are willing to give the time and attention necessary to complete a thorough inspection. The engine inspector's duties should begin where the engineer's leave off. The selection of competent men as inspectors is a matter of prime importance. Too often the position of engine inspector is filled by a superannuated engineer or a mechanic of inferior rank. Such practice is entirely wrong; the position should be filled by the best mechanic available. The results to be obtained from proper terminal inspection, first, to determine the repairs necessary, and second to pass upon the quality of the completed work, will fully warrant the payment of a salary comparing favorably with that of a foreman.

The inspection of incoming engines should be of the most thorough nature. All parts of the locomotive should be examined, not occasionally, but at the end of every trip, and all of the defects, even to the most insignificant and apparently unimportant ones should be reported and given attention.

The importance of the wiper as a factor in efficient engine house work should not be overlooked. Engines which are covered with grease and dirt cannot be properly inspected. Cracks in frames, rods, blades or other vital parts of the locomotive may be so effectually covered by a coating of dirt that their detection is impossible. Such defects undiscovered will lead to failures in service, possibly entailing the destruction of equipment or the loss of human life. Locomotives may be thoroughly cleaned and kept clean at the cost of a few mills per mile run, and such expenditure is covered many times over by the improved inspection made possible. The wipers themselves may be trained to report to the inspector or foreman defects which they discover while cleaning locomotives, and many break downs and failures may be avoided by their so doing.

Clean engines not only permit of more adequate inspection, but conduce to a higher efficiency of the labor applied in their repair. Almost any mechanic will work with increased energy, and with greater pride in the work when the parts which he must handle are free from grease and dirt.

Adequate inspection provided for, the next necessary step is to insure that the defects discovered are promptly and effectively repaired. The proper performance of running repairs at engine houses depends far more upon the organization of force, and the quality of supervision, than it does upon equipment and facilities. The engine house force, no matter how small or how large, may be so assigned as to give to each individual workman the care of and responsibility for the repairs to certain parts of the locomotive. Ample and competent supervision to insure not only the performance of all work ordered, but to inspect its quality, is a necessity if high power efficiency is to be maintained.

To summarize, the duties of the engine house are: To provide competent and continuous inspection of locomotives in service, to insure the discovery of defects in the incipient stage, and to promptly and effectively repair all defects so found, preventing minor defects from causing, through neglect, the necessity for extensive repairs. Simple as this formula appears, many engine house foremen will raise the objection that the volume of work absolutely necessary to keep the power in service is so great that the less important items of repair must be neglected. At an engine house where this policy has been employed some difficulty may be experienced at first in securing proper attention to defects of a minor nature. In such case it might be well to start with only two or three engines just out of the main shop, giving them particular attention to see that careful inspection is made

after each trip, and that all defects are corrected before the engine returns to service. By the process of gradually taking up more and more locomotives on this plan, it will soon be found that the volume of heavy running repairs has so decreased, that the original force employed will be more than sufficient to keep the power in the best of condition.

REMOVING GASKETS FROM BULLSEYE LUBRICATORS

BY J. A. JESSON

Air Brake Foreman, Louisville & Nashville, Corbin, Ky.

The device shown in the engraving was designed to facilitate the removal of sight feed gaskets from Detroit bullseye lubricators. These gaskets often become stuck in place, and owing to their location below the follower threads, are rather difficult to remove. The body of the device is shown at *A*. It is threaded on the lower end to fit the follower threads in the lubricator body and the stem is threaded to take the nut *D*. Before the nut is applied the sleeve *C* is slipped over the stem, the four attached pins *B* being placed in holes through the body *A*. With

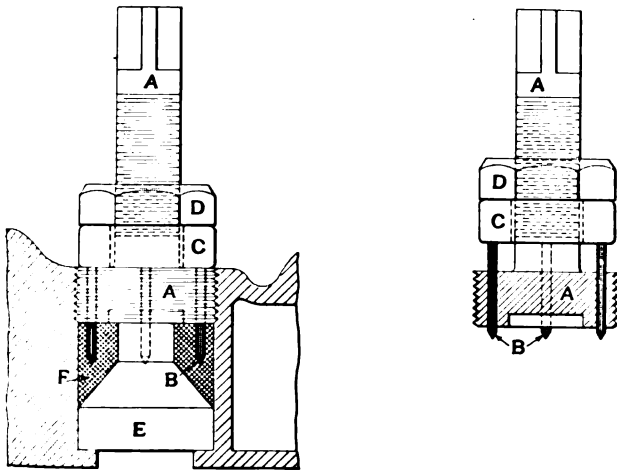

Device for Removing Gaskets from Bullseye Lubricators

the device screwed into position in the lubricator, the nut is turned down against the sleeve, thus forcing the pins into the gasket *F*. The whole device is then unscrewed from the lubricator body, the gasket being loosened and removed by following the threads. The four pins *B* are $\frac{1}{8}$ in. in diameter and are made from tool steel. It is advisable to provide a ball thrust bearing in the sleeve *C*, in order to insure a free working nut and to remove the tendency to bend the pins when forcing them into the gasket.

GRINDING DISTRIBUTING VALVES

The accompanying illustration shows a home-made air engine for grinding six different surfaces of the distributing valve of the Westinghouse air brake at one time. The device was invented by W. L. York, of the Ferguson shops of the Cincinnati, New Orleans & Texas Pacific. It is in reality a small engine, equipped with a valve and cylinder, as indicated, the cylinder being the barrel shown on the further side of the engine. The guides for the crosshead are supported on uprights bolted to the base of the machine. The valve is operated by an eccentric on the near side of the flywheel. The crank on the front of the engine oscillates a plunger, which is attached to the application piston. On the back end of this piston another rod is fastened, which operates a lever, with a fulcrum, as indicated in the illustration, which transmits the mo-

tion to a rod that oscillates the equalizing piston. The device will grind the application piston ring, the application valve, the equalizing valve, the equalizing piston ring, the graduating valve and the exhaust valve all at the same time, and will perform

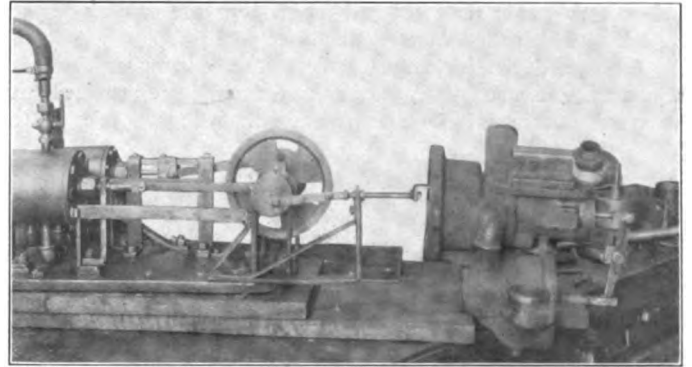

Small Engine Used for Grinding Six Surfaces of Distributing Valves

the job in one and one-half hours, whereas it would require four hours to do the grinding by hand in the usual way. The small engine may be operated by air or steam.

RECLAIMING BOLTS WITH BATTERED THREADS

BY J. P. NOLAN

Assistant Superintendent, Morgan's Louisiana & Texas Railroad, Algiers, La.

It is the general practice in railroad shops when reclaiming old bolts accumulated from the dismantling and repair of equipment to cut off and rethread all those having threads battered or bruised so that a nut will not go on. Where the threads are not badly worn or the material fractured this practice not only wastes a great deal of material but results in a large accumulation of short bolts for which there is no further use.

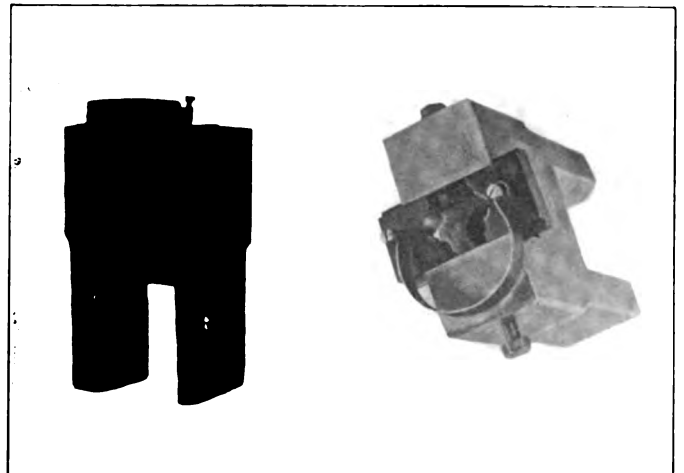

Die Plate and Dies Removed from the Vise

A simple device for reclaiming such bolts without cutting off the ends is shown in the illustration. A die plate or socket is fitted to an ordinary parallel vise from which the screw has been removed, the movable jaw of which is operated by an air cylinder. Dies of different sizes suitable for the bolts to be worked on are fitted to the screw plate, the two halves of each pair being connected by a flat steel spring as shown in one of the illustrations. When air is released from the cylinder and the vise opened the dies are thrown open by the spring and the bolt to be worked on is placed between the dies at the end of the threads next to the head. The air is then applied and the

vise closed. A reversible air motor suspended by means of a pulley and counterweight and provided with a suitable socket is used to unscrew the bolt from the die, thus restoring the threads to serviceable condition. This operation requires much less time than the cutting off and rethreading of the bolts, and since they retain their original length they are suitable for the work to which they were originally applied.

A simple device for restoring the threads on smaller size bolts, such as $\frac{3}{8}$ in. and $\frac{1}{2}$ in., consists of a screw plate provided with a crank attachment similar to a carpenter's brace. Dies of the

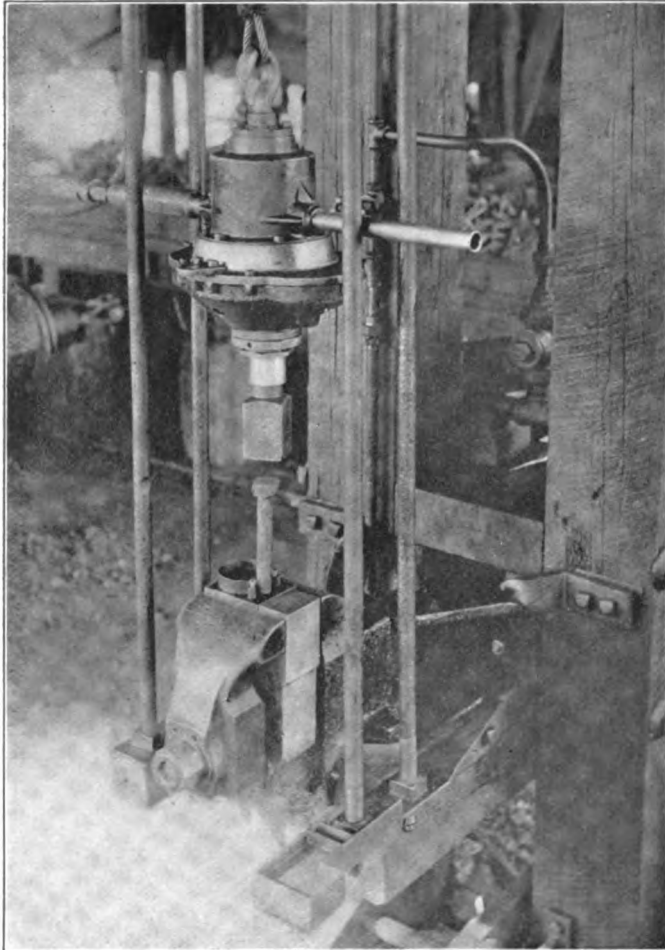

Bolt in Position to Be Threaded Out of the Dies with an Air Motor

required sizes are provided to fit the screw plate. For rapid work the bolts are held in a vise operated by an air cylinder, the die plate being run over the threads by hand. In this way the threads of small bolts are restored quicker than they could be reclaimed by cutting off and rethreading.

REMOVING INDENTATIONS IN SUPERHEATER SMOKE TUBES

BY H. M. BROWN

Shop Superintendent, Chesapeake & Ohio, Huntington, W. Va.

Superheater smoke tubes, because of their large diameter, are very readily injured by rough handling. Indentations are formed in removing and rattling, especially where coke or old arch brick is used in the rattler to assist in removing scale. They not only form obstructions which interfere with the insertion of the superheater elements but also increase the liability of the tubes to collapse under pressure.

A jack for removing indentations from $5\frac{3}{8}$ in. tubes is shown in the engraving. After the tubes have been rattled and welded

they are carefully inspected for indentations, which are marked with chalk. The air jack, which is attached to a piece of $\frac{3}{8}$ in. pipe about 30 ft. long, is placed over each indentation on the outside of the tube and the pipe marked with chalk at the end of the tube. The jack is then inserted in the tube, the chalk marks on the pipe serving as guides for its proper location under

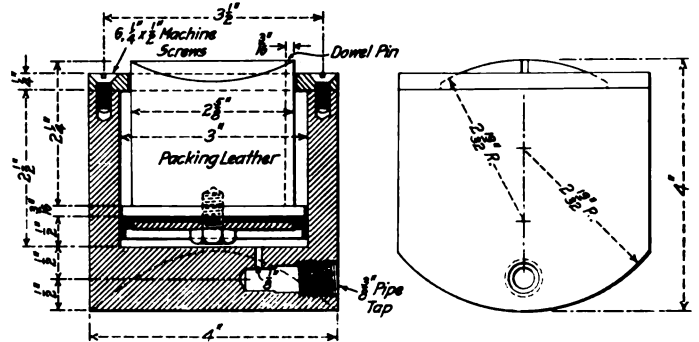

Device for Removing Indentations from Superheater Smoke Tubes

the indentations. When properly placed air is applied and by lightly striking the tube with a hammer the indentation is quickly removed and the tube pressed back into perfect shape. This work can be done with great rapidity and the tubes are in perfect condition when returned to service.

HORIZONTAL DRILLING ATTACHMENT FOR A RADIAL DRILL

BY V. T. KROPIDLOWSKI

The horizontal drilling attachment shown in the illustration may be used to good advantage on a radial drill for counter-sinking holes in the flanges of back tube sheets and many other operations of a similar nature. The body of this device, shown at A, may be forged solid from a piece of mild steel, such as

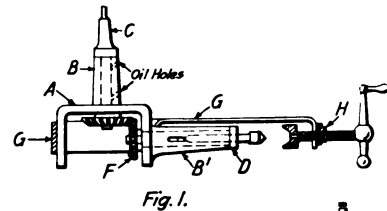

Fig. 1.

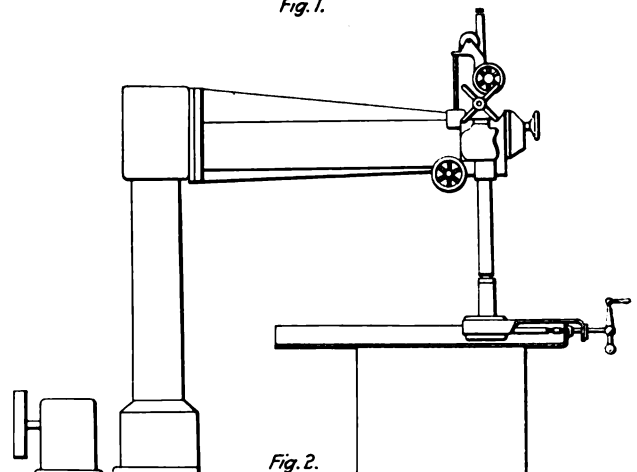

Fig. 2.

Horizontal Drilling Device for Use on Radial Drills

an old axle, and the recess for the gears cut out, or it may be made from two pieces of round steel, one end of each being split and drawn out flat to the required dimensions, the flat portions being welded and shaped so that the two bars are at

right angles to each other as shown in the drawing. The bars are then finished in a drill press to form the bearings of the spindles *B* and *B'*. Spindle *B* has a Morse taper extension *C*, for insertion in the drill spindle at one end and a bevel gear at the other. Spindle *B'* has a thrust collar *D* on the outer end, which is fitted with a Morse taper socket. The bevel gear on the inner end meshes with the gear on spindle *B*. A yoke *G* of flat merchant iron is bent around the body of the device, the ends being twisted and extended to support a cross piece *H* which carries a feed screw. The work is clamped against the drill by means of the feed screw, the overhang of the horizontal spindle being supported by the work. The illustration shows the device in use for countersinking holes in the flange of a back tube sheet.

MODEL LOCOMOTIVE BUILT BY ERIE APPRENTICES

The apprentices employed in the shops of the Erie Railroad at Meadville, Pa., have designed and built complete a model of a Pacific type passenger locomotive.

Meadville is one of several points on the Erie where apprentice schools are maintained. To test the proficiency of the boys at the Meadville school, the work of building a model engine was entrusted to them, and after eleven months and one day, they completed their task and presented to their master mechanic the miniature engine shown in the accompanying illustration. The

The boiler was tested at 105 lb. per sq. in. hydrostatic pressure. The total weight of the engine, loaded, is 623 lb.; total weight of engine and tender 812 lb.; capacity of tender, coal, 37 lb., water, 11 gal.; boiler pressure 25 lb.; the number of parts in the engine and tender is 4,511.

The work was carried out under the direction of F. G. De-Saussure, instructor of apprentices at the Meadville shops. The model is to be placed on exhibition in the window of the Erie's downtown offices at 399 Broadway, New York.

RUNNING REPAIRS*

BY RAILROADER

From statements that appear quite frequently in the magazines it seems that each road has what is considered a fixed charge per locomotive for despatching, and if this charge is exceeded there has to be an explanation made as to the cause. Sometimes it is too much labor at the ash pit, at other times it is due to too much supervision and again it may be brought about by using too high priced labor in handling the engines. In any event, a reduction in forces has to be made. At times extra expenses creep in due to causes beyond control of the shop or terminal management, such as weather conditions, or a falling off of business for a few days, but the reduction has to be made, nevertheless.

Reduction of forces on running repairs should be made only after a careful study as to conditions. As a rule comparisons are

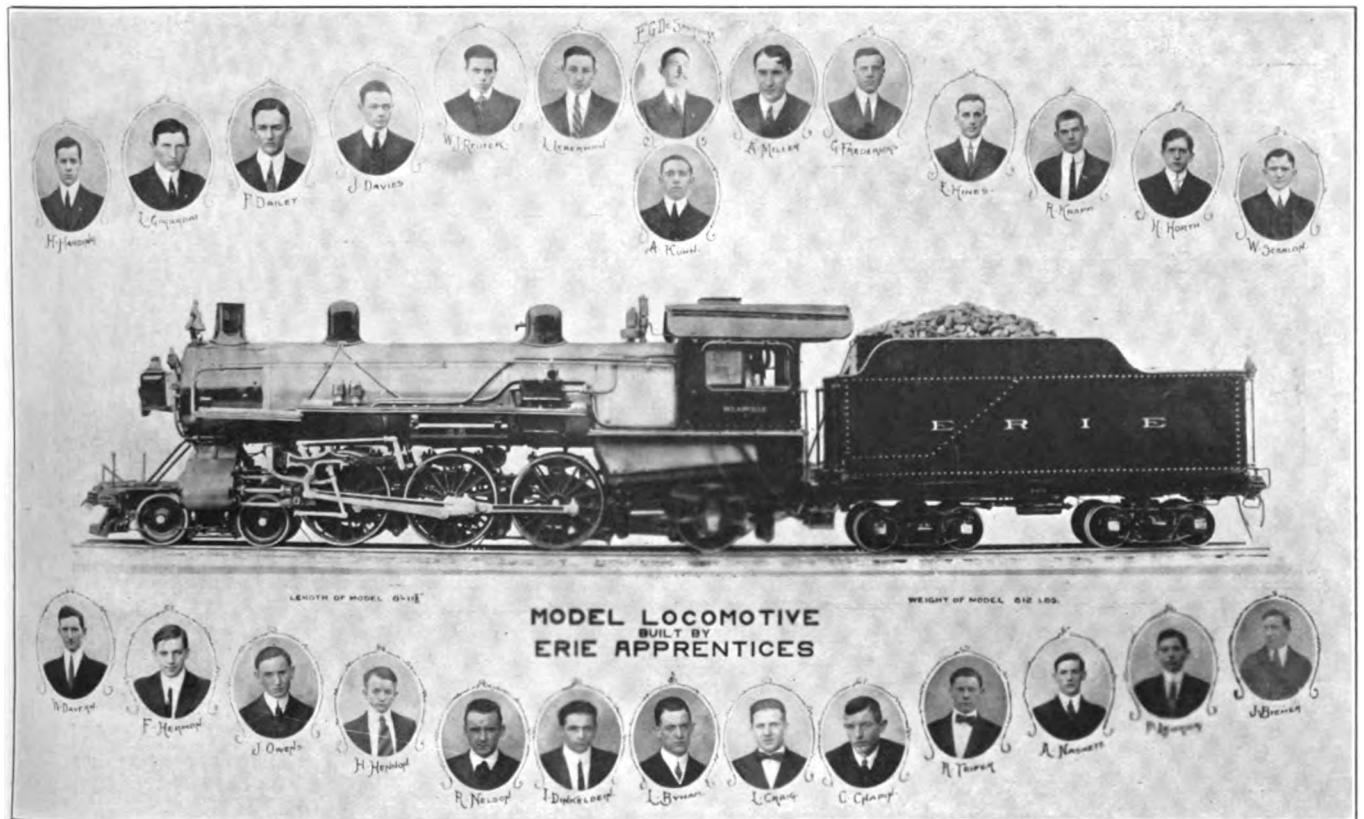

Group of Erie Railroad Apprentices and Model Locomotive Built by Them

locomotive has been named Meadville. The work of building it was begun December 13, 1913, and the engine was completed November 14, 1914. There were 26 apprentices engaged in the work, including one blacksmith, five pattern makers, two boiler makers, one tinsmith and 17 machinists. All drawings were made by the boys and the cylinders were designed by one of them. It took 350 patterns and core boxes to accomplish the work. On a test the engine attained a speed of 572 revolutions per minute.

made between each month and the preceding one and the same month of the previous year. Sometimes when this comparison is made there is no attention given to the condition of the locomotives at each period. This plays an important part in the running repair charges. If the power was in good condition, inspection cost less and the number of fires drawn was less, due to little if

*Entered in the competition on Engine House Work, which closed July 15, 1914.

any tube trouble; whereas the month with which comparison is made may have required much more work and expense due to the poor condition of the power. As it begins to get run down, engine failures become more frequent and every one is in trouble, a good portion of their time being spent in explaining the cause of failures.

Great care must be exercised in organizing the working force at a terminal, particularly if it is a large one, handling from 100 to 120 locomotives each 24 hours. The main thing to be looked after is the getting of the engines over the ash and inspection pits so as to make room for others. At a terminal of this nature, a few years ago, there were three divisions entering, and passenger trains came in as a rule from each division with only an hour's difference in arrival time. This held out freight trains, and they afterward arrived in groups. The work was successfully handled by the engineers making out their reports clearly and using good judgment in the work they reported. The shop had information through the despatchers as to any delay caused by an engine, consequently, the shop men were prepared to either clean the fire or draw it without any question. It was a rare case when an engine had to be sent back to the pit from the roundhouse to have the fire taken out. The inspectors were on hand at the pit, made a thorough inspection and promptly notified the roundhouse office of all defects. In many cases they did some of the tightening up of loose nuts, applying pins or keys that were missing, etc., but for engines on hard runs they did not do any of this work but reported it to the office with the rest of the work.

The roundhouse force was so organized that a machinist and helper, or a boilermaker and helper were assigned to particular

Engine house foremen should study their men and their work, place them accordingly and change them at intervals so that there will be no favors shown. Because one man may be good on valve work does not mean that others cannot learn to do the work if given the chance. Try to find out what is in a man; give him a trial and nine times out of ten he will come out all right. This will be encouragement for others to try. A foreman should never call his men to account for mistakes on the floor of the shop within sight and hearing of their fellow workmen; he should never by any act hold up any man to the ridicule of his fellows. If a reprimand has to be given, have the man come to the office, where he can be spoken to and corrected without his losing his self respect.

ADJUSTABLE DRILLING STAND

BY GEORGE B. McCOY

An adjustable drilling stand for firebox work is in use on the Canadian Government Railways, and is the design of an employee of that system at Truro, Nova Scotia. The engraving shows the application of the device to firebox work, and also gives the details. The supporting piece is made up of steel tubing arranged so that it can be adjusted for different lengths according to the position occupied in the firebox. A double center is placed in one end to prevent turning, with an adjustable single center in the other to tighten the stand in place. The drill center is placed against an arm which is held at right angles to the main support of the drilling stand. This is accomplished by means of a boss on the end drilled so that it

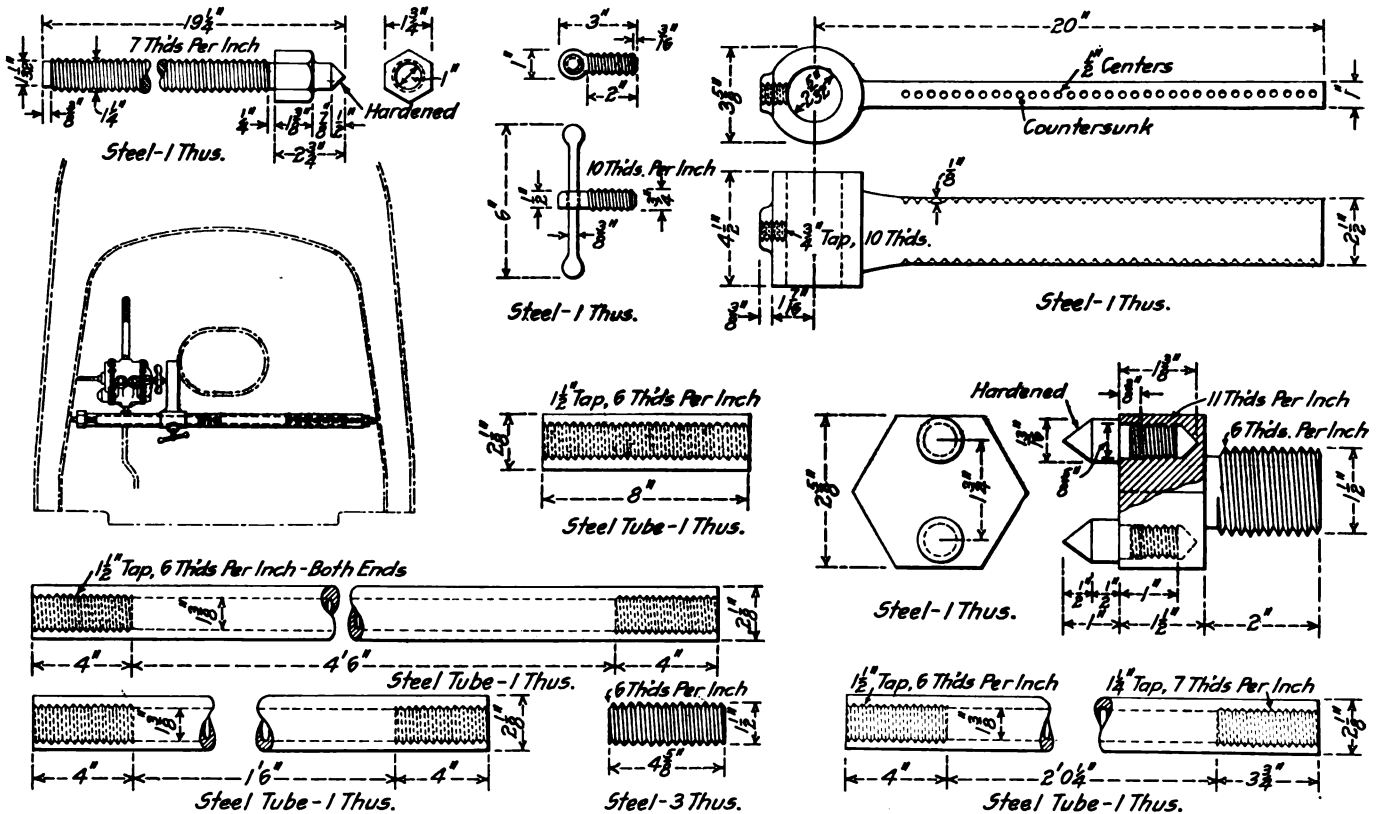

Adjustable Drilling Stand Used for Firebox Work on the Canadian Government Railways

jobs, which they handled for from two to three months when they would be changed to other work and another set of men took their places. By this method the men got a chance to do all classes of work so that if for any cause a man was absent there was always some one on hand who was acquainted with his work. There was no breaking in of new men on running repairs and therefore less chance for poor work.

fits over the steel tubing, and it is then clamped in the desired position by means of a set screw. This arm has center marks placed at convenient distances along its length to provide adjustment for the drill.

While this device is intended primarily for firebox work it can be readily seen that it is adaptable to many other positions about a locomotive where drilling is necessary.

NEW DEVICES

BRAKE SHAFT DROP HANDLE AND RATCHET

For some classes of cars, such as drop end gondolas and cabooses where a hand wheel is objectionable, or for cars of great carrying capacity where a leverage is desired at the brake shaft greater than that afforded by the standard brake wheel, it is customary to employ a ratchet head with a drop handle instead of the brake wheel. The accompanying illustration shows a device of this kind which has recently been developed on the Buffalo, Rochester & Pittsburgh for application to the square brake shaft* now in service on its equipment.

The drop handle and ratchet head form a complete unit which is interchangeable with the brake wheels used on the

pawl are three teeth which are held in engagement with the toothed disc of the ratchet by gravity when the handle is in working position. Projecting from the toothed end of the pawl is a tongue, shown at *F*, which extends into a pocket formed in the housing, just above the jaws between which the drop lever is pivoted. When the lever is in the horizontal position, the pawl engages the teeth on the ratchet wheel, the position of the parts being as shown by the full lines. When the lever moves from working to release position the cam on its upper end makes contact with the lower face of the tongue on the pawl, causing the pawl to rotate upward about the pin *E* to the position shown by broken lines and disengaging it from the ratchet. The cam end of the lever and the tongue of the pawl are so formed that when the lever is swung about halfway from its vertical to its horizontal or working position, the contact ceases and the pawl is fully engaged. The operator is thus

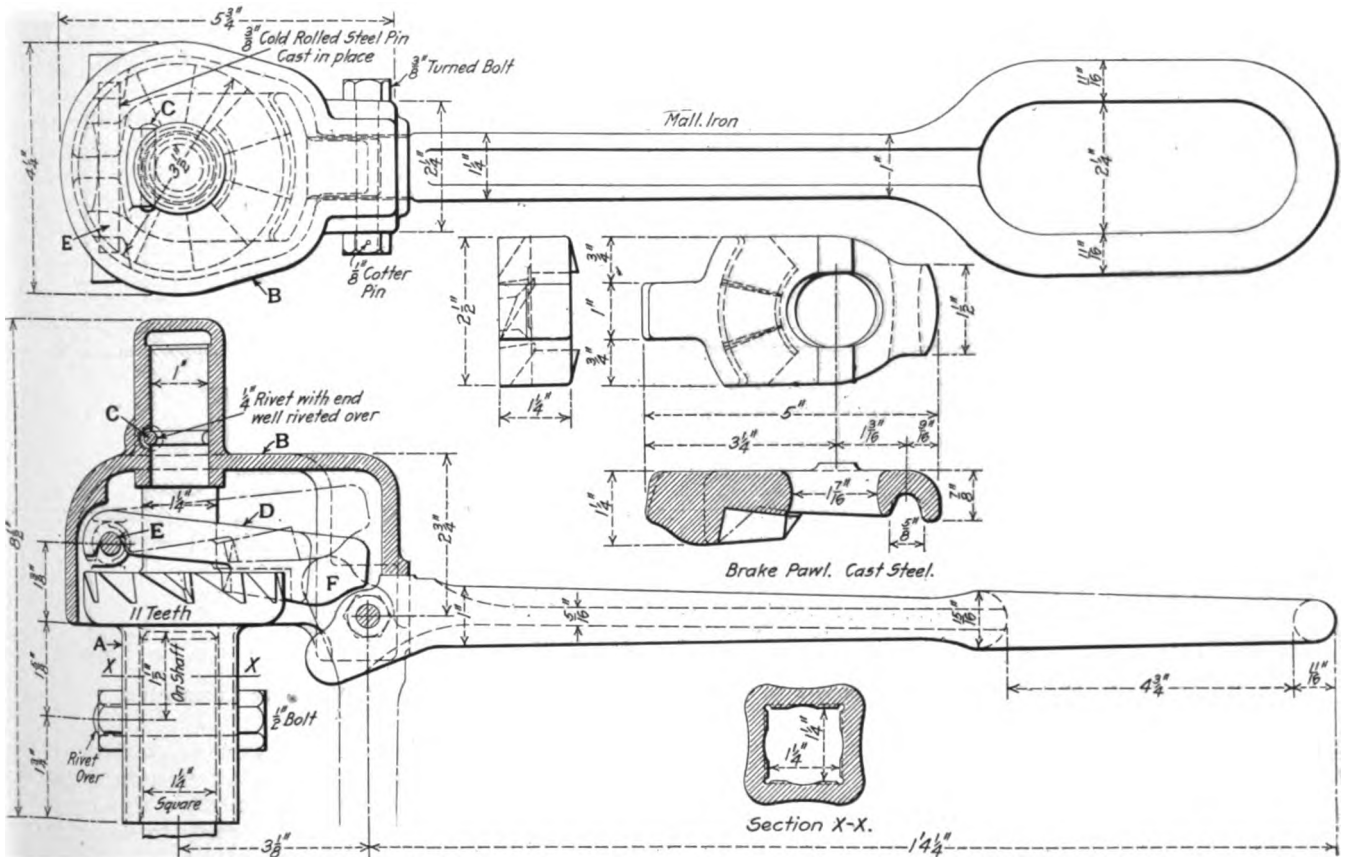

Brake Shaft Ratchet Head and Drop Handle Developed on the Buffalo, Rochester & Pittsburgh

square shafts. The entire device is composed of four castings having a total weight of about 15 lb. The housing and drop handle are malleable iron while cast steel is used for the ratchet and pawl. Referring to the drawing, the ratchet *A* is formed with a socket below the toothed disc and a spindle above the disc. The socket fits the end of the square brake shaft, to which it is secured by a single bolt passing through the shaft; the spindle above the disc serves as a support and bearing for the housing *B*, which may be freely revolved, but is locked against vertical movement by the riveted pin *C*. The pawl *D* surrounds the spindle and is pivoted at one end upon the pin *E*, cast in place in the housing. At the opposite end of the

safeguarded should power be exerted against the brake before the lever reaches the horizontal position. The loop form of lever handle protects the operator in case his grip should slip when setting the brakes.

The design of this device is very simple, and it is claimed to have proved its reliability and efficiency in service. Aside from finishing the ratchet spindle and its bearing in the housing, the only machine work required in fitting up the parts is the drilling of a few holes; but little skill is required in assembling and applying it to the brake shaft.

This brake shaft handle was designed and has been patented by F. J. Harrison, superintendent of motive power, and W. J. Knox, mechanical engineer of the Buffalo, Rochester & Pittsburgh.

*For description, see *Railway Age Gazette, Mechanical Edition*, December, 1914, page 647.

A HIGH PRESSURE GAS VALVE

To meet the severe requirements of a satisfactory stud valve for use in high pressure gas cylinders the valve shown in the illustration was developed by the International Oxygen Company, 115 Broadway, New York, for its own use. It has now been tested in service for several years by this company and other gas manufacturers, and is claimed to have proved successful under all conditions.

The valve is designed for use with pressures up to 2,500 lb. per sq. in. and is made of metal throughout. The construction is such that no packing is required in any part, thus eliminating a source of danger when inflammable material is used, as well as a cause of loss from leakage. The body is forged from Tobin bronze, while the other parts are made of metals which are non-corrosive to gases or to weather conditions. The flow of gas is controlled by a diaphragm, as shown in the sectional view of the valve, which is made of a tough, springy material that is claimed to withstand all the strain put upon it without cracking or breaking, even after years of service. The diaphragm takes the place of packing material, and in this way the usual stuffing box is entirely eliminated. It is slightly concave, and normally sets away from the seat of the valve a sufficient distance to permit a full opening without the aid of the gas pressure; this permits

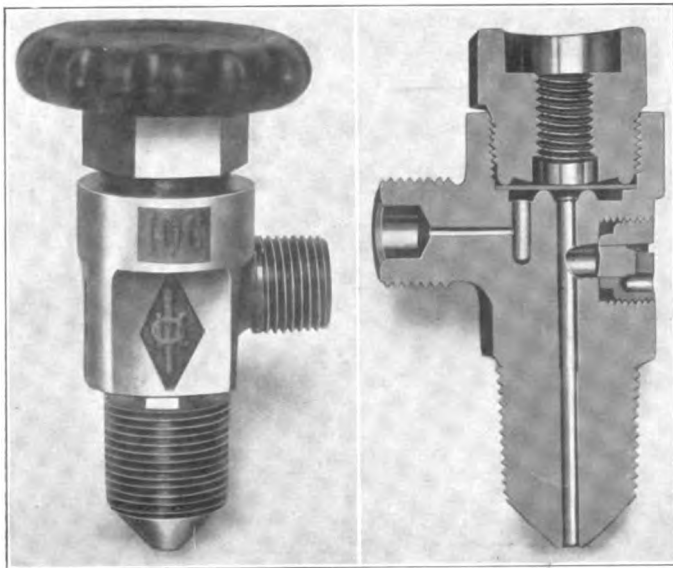

Stud Valve for High Pressure Gas Cylinders

all the gas in the cylinder to be used down to atmospheric pressure.

The safety plug used in this valve is designed to meet the requirements of the Bureau of Explosives of the Interstate Commerce Commission. It is filled with fusible metal melting at, or below, the boiling point of water, and is provided with three passages, each in a straight line with the direct action of the gas in the cylinder, to permit the outflow of the metal. The plug has a hemispherical seat which forms a tight joint when screwed into the body of the valve by compressing a phosphor-bronze disc. No part of the plug projects beyond the body of the valve, thus protecting it against breakage. It will not blow when subjected to the direct rays of the sun or to any other atmospheric condition, but the fusible metal will melt and the valve will blow when placed in a fire before the expansion of the gas can do any damage to the cylinder.

The construction of this valve is very simple, and all parts are so arranged that they are readily accessible whenever examination or renewal is required. The hand wheel is so designed that it may be removed or left as a permanent part of the valve.

SAFETY CUT-OUT VALVE

G. H. Wilson, a locomotive engineer on the Atchison, Topeka & Santa Fe, has invented a cut-out valve to replace the ordinary cut-out valve now used in the train line directly under the engineer's valve for the purpose of cutting out this valve when two or more engines are coupled to one train. The special features of the new valve are that it can be used in emergency if there is an accident to the engineer's valve; it is provided with a warning port which gives assurance that there is no train line stoppage between the rear engine and the leading engine as soon as the leading engine is cut in; it permits the rear engineman to instantly assume full control of the brakes in double-heading service, provided he finds it necessary to do so, and lastly, it is so designed that it will not be possible for the helper engine to cut off from the train until the second engineer takes control of the brakes, without the brakes being set throughout the entire train. Its use will eliminate the necessity of having a cut-out cock on the train line leading to the front end of the locomotive.

This valve is in brief a three-way cock with the openings *A* leading to the engineer's valve, *B* to the main train line and *C* to the locomotive train line leading to the front end. Fig. 1 shows this valve in position for operating the train under or-

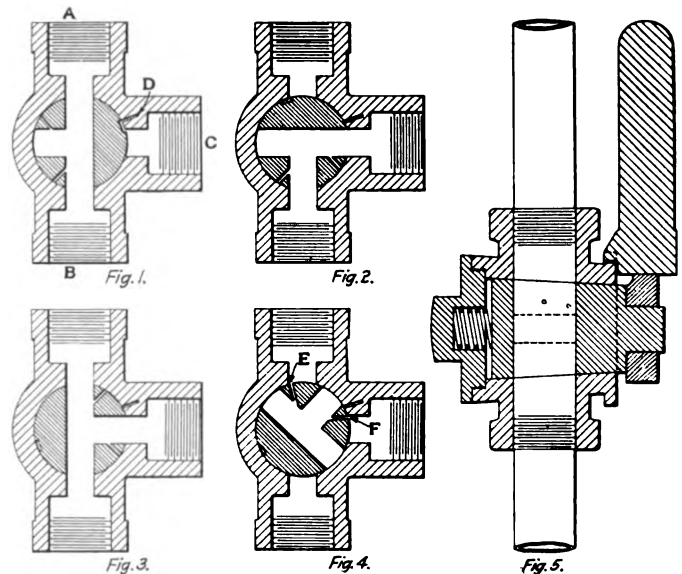

Safety Cut Out Valve for Locomotives

dinary conditions. When an extra engine is connected to the front of the train and the air cut in, air escaping through the warning port *D* informs the engineer of the second engine that the engineer of the leading engine is ready to assume control of the brakes. By turning the handle of the valve through one-quarter of a revolution, the valve will assume the position shown in Fig. 2, and thus cut out the engineer's valve of the second engine, giving control of the train to the engineer on the first engine. If the engineer of the second engine desires to assume control of the train he will turn the handle of the valve through another quarter turn, placing the valve in the position shown in Fig. 3, which will place his engineer's valve into operation, controlling the brakes on the leading engine as well as on the train. When it is desired to pick up cars on the head end of the engine it is possible to charge the train line by placing the valve in the position shown in Fig. 4, the openings *E* and *F* charging the train line of this string of cars without disturbing the pressure in the train line of the train itself. After charging the valve is placed in the position shown in Fig. 3.

When a pusher engine is used on the rear of the train these same features obtain with that engine. By the escaping of air

through the warning port *D* the engineer of the rear engine will know that there is no obstructed passage in the train line, and will place his valve in the position shown in Fig. 2, so that the brakes on the helping engine may be operated by the leading engineer. In cases where it is necessary for an engine to haul a train running backwards, the position of this valve will be that shown in Fig. 3, the cut-out cock at the rear of the tender, of course, being closed. Fig. 5 shows cross section through this cut-out valve. Further information regarding this valve may be obtained from Thomas Ogden, Box 252, Rawlins, Wyo.

BLOWER PIPE DRAIN FITTING

Much annoyance is caused to persons standing near a locomotive when the blower is started by the spraying from the stack of dirty water which has accumulated in the blower pipe while the blower valve was closed. Trouble is also experienced from the same cause in cold weather by the freezing of the blower pipe. The blower pipe fitting, a sectional view of which is shown in the engraving, is designed to overcome these conditions by automatically draining the blower pipe at all times when the blower valve is closed.

The device consists of a body of malleable iron in which is inserted a very tough Tobin bronze bushing to form a seat for the ball check. The ball is of gunmetal $1\frac{1}{8}$ in. or $1\frac{3}{16}$ in. in diameter, depending upon the size of the fittings, and is carefully ground to form a perfect sphere. The gunmetal mixture is especially adapted to resist the corroding action of steam at high temperatures. The ball may be easily removed by disconnecting the blower pipe nipple and is kept in place by means of the lugs in the smokebox connection.

When not in use the ball is unseated by gravity and all con-

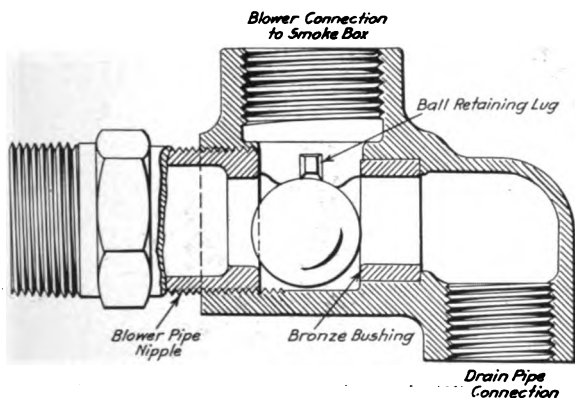

Automatic Drain Valve for Blower Pipe

densation is free to drain from the pipe through the elbow connection from which it may be piped to any convenient point of discharge. As soon as the blower valve is opened steam pressure seats the ball, thus closing the drain port and permitting the entrance of steam to the blower nozzle only. Where fires are started by attaching a hose from the roundhouse steam line to a blower pipe connection on the engine this device is especially useful. In such cases the drain pipe may be arranged for connection to the roundhouse hose and the blower operated merely by opening the valve in the steam line. The pressure in the drain pipe causes the ball to seat against the end of the blower pipe nipple, shutting off connection with the blower pipe and preventing the possibility of the steam backing up in the boiler should the blower valve in the cab be leaky. The use of a valve or plug in the connection for the roundhouse hose is thus made unnecessary.

This device was developed by the Watertown Specialty Company, Watertown, N. Y., and is claimed to have rendered effective service in tests conducted during a period of several months.

It is usually made with fittings for 1-in. and $1\frac{1}{4}$ -in. blower pipes, but modifications of the general design of the body can be made to suit special requirements.

RADIAL DRILL

A radial drill in the design of which is incorporated a new type of drill head and arm has been placed upon the market by the Willmarth Tool Works, Cleveland, Ohio. The most prominent feature of this machine is the manner of moving the head and arm for locating the holes to be drilled. The head rotates about a large circular bearing on the arm, and the arm rotates about the column as in the usual type. This produces a double swiveling motion, so that any hole within the capacity of the machine may be easily located. A self-locking spiral gear and rack are provided for moving the head. The bearing of the head on the arm is 17 in. in diameter, and is provided with an annular ring inside for holding it central and a heavy pivot bolt for holding the two together. An eccentric clamp locks the head to the arm.

The column is of the post and sleeve type. The post has a large and heavy lower portion, and extends up to the top mem-

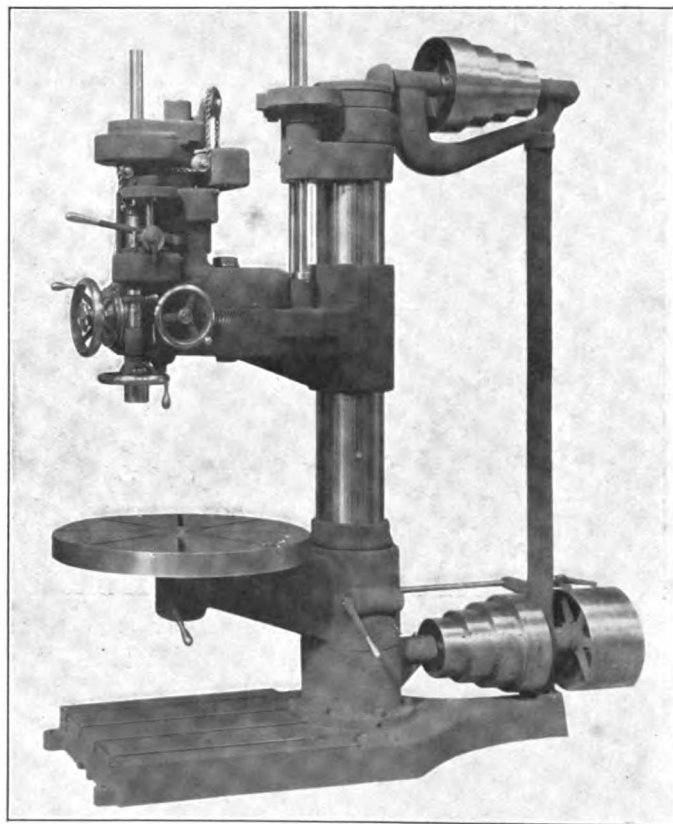

Willmarth Radial Drill

ber, which is bolted to it, making a braced construction and adding materially to the stiffness. The column sleeve telescopes the post, and has bearings at both the top and bottom, also a large ball thrust bearing at the bottom. The sleeve has a binding clamp at its lower end. The arm is of cylindrical box section, and heavily ribbed on the inside. It is elevated or lowered by means of gears at the top operating a coarse pitch screw hung on ball bearings.

There are eight changes of speed, from 35 to 375 r.p.m., arranged in geometrical progression. Four changes are obtained by the cone pulleys and four more by the back gearing, which is provided in the spindle driving gears. The tapping mechanism is operated through a jack shaft in the head, running at high

speed, and driving through ring clutches, which are self adjusting. They are operated by means of a lever in front of the machine, enabling the workman to easily start, stop or reverse the spindle.

The spindle is of special steel, and is provided with an ample ball thrust bearing. It has a No. 5 Morse taper socket and is 3/4 in. in diameter at its large end and 1 3/4 in. at its smallest section. The feeding mechanism is of the selective gear box type. Six changes of feed are provided, ranging from .006 in. to .027 in. per revolution of the spindle. These are instantly available by operating the dial on the front of the feed box. A quick return hand wheel is attached to the feed pinion shaft, and the engagement of the worm to it is made by means of a friction ring controlled by a nut in front of the hand wheel. Both depth gage and automatic trip are incorporated in the feed mechanism.

The bearings throughout are bushed with high grade special bearing bronze, and ample oiling facilities are provided. No cast iron gears are used in this machine. In accordance with their

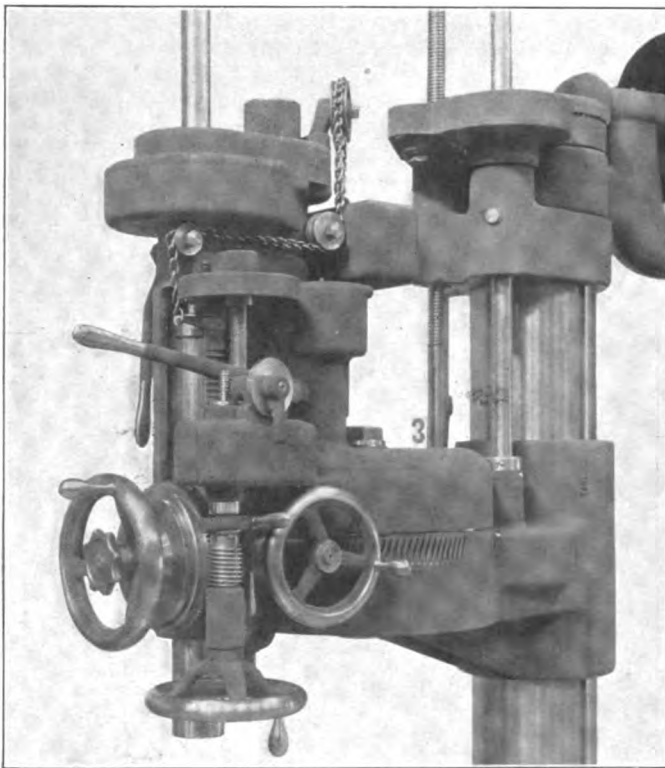

Rotating Head for Wilmarth Radial Drill

requirements the gears are of steel, bronze or a specially high grade semi-steel. All gears are fully guarded.

The principal dimensions of the machine are as follows:

Range of drilling.....	48 1/4 in.
Greatest distance from spindle to base.....	52 1/2 in.
Greatest distance from spindle to table.....	27 in.
Vertical traverse of spindle.....	11 1/4 in.
Vertical traverse of arm on column.....	28 in.
Height of machine.....	96 in.
Weight of machine.....	3,500 lb.

SERVICE TEST OF AUTOMATIC HOSE CONNECTORS.—A service test of the automatic hose connectors manufactured by the Robinson Coupler Company, Washington, D. C., has been in progress on the Canadian Northern since June 10, 1914. The cars equipped are in ore service on a branch line 165 miles long and it is understood that under varying weather conditions the equipment has required no attention for renewals or repairs, tight joints having been maintained with temperatures as low as 35 deg. below zero.

MACHINE RECORDS.—Some method of recording the location and movements of machines is necessary, particularly in large plants and those in which an appraisal is to be kept up to date.—*American Machinist.*

METALLIC SALTS PYROMETERS

A method of measuring high temperatures wherever heat is applied has been developed by the Carl Nehls Alloy Company, Detroit, Mich., and is based upon the melting points of various mixtures of metallic salts. Molecular mixtures of metallic salts are made up which have melting points ranging between 220 deg. and 1,330 deg. Centigrade. Practical means have been devised for using these mixtures in place of costly instruments. They are also very useful for checking other pyrometers.

The mixtures are made up in two forms, the solid and the paste. In the solid form they are cast into cylinders, 7/16 in. in diameter and 3/4 in. long. Each cylinder is wrapped in paper on which is printed its correct melting temperature in degrees Centigrade. For all temperatures below 500 deg. Centigrade

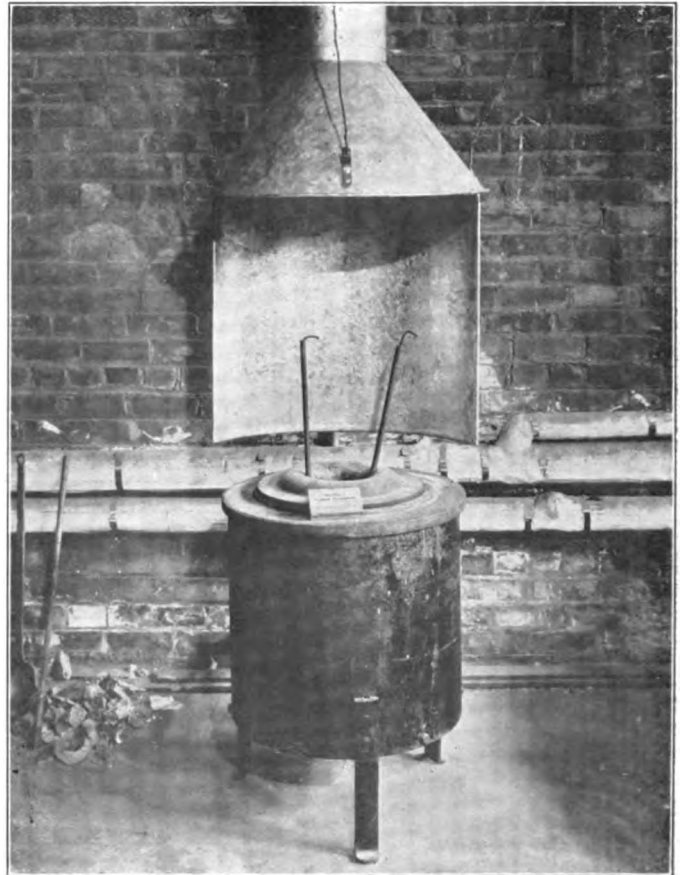

Method of Temperature Indication in Metal or Salt Bath Furnace

(932 deg. F.) the cylinders, which are known as Sentinel pyrometers, may be used in air-tight glass tubes, especially provided for that purpose. The same cylinder may thus be used repeatedly. For other purposes where the use of the tubes is not practicable small porcelain saucers are provided which prevent the wasting of the salts and the littering up the place where they are used. This also enables the same salts to be used several times before renewal is necessary.

In the paste form the mixtures are packed in tins, each of which contains enough to make several hundred determinations. The temperature at which furnaces, ovens, retorts, steam pipes, etc., are operating may be determined by placing a steel bar on which a small amount of the various pastes has been daubed, in the furnace or against the part. The temperature will be between the melting points of the last paste to melt down and the one having the next higher melting point. By using a long bar one can determine whether the temperature is uniform in the front and back, top and bottom, or the corners of a furnace, oven or kiln.

This method of determining temperatures is especially useful

in connection with the hardening of tools in a forge fire. A paste is selected that represents the correct hardening temperature for the tool and a small amount daubed on the tool. The melting of the paste clearly indicates the time when the tool can be taken out of the fire and quenched. Surrounding the tool with a piece of sheet steel or inserting it in a piece of gas pipe will add to the accuracy of the results by keeping the paste from coming in contact with the fuel.

A method of using the Sentinel cylinders is shown in the illustration. Two tubes or pipes with plugs in the bottom ends are placed in the furnace. Sentinel cylinders from different melting temperatures are dropped into the tubes and metal rods are stood on top of the cylinders. When the cylinders melt the rods will drop to the bottom of the tubes. When one rod is lowered and the other is not the temperature is between the melting points of the two cylinders. These need be only 10 degrees apart. This is very useful for finding the temperature of molten metals, salt bath furnaces, etc.

SANITARY DRINKING FOUNTAIN FOR PASSENGER CARS

A combined drinking fountain filter for passenger cars has been brought out by Henry Giessel & Co., Chicago, and has been giving good results in service on one of the western roads. It is known as the "North Pole" sanitary drinking fountain, and is made up of a filter, a storage tank for the filtered water, a cooling pan and an ice box. The fountain occupies a space 14 in. by 17 in. by 48 in., and all parts are accessible for in-

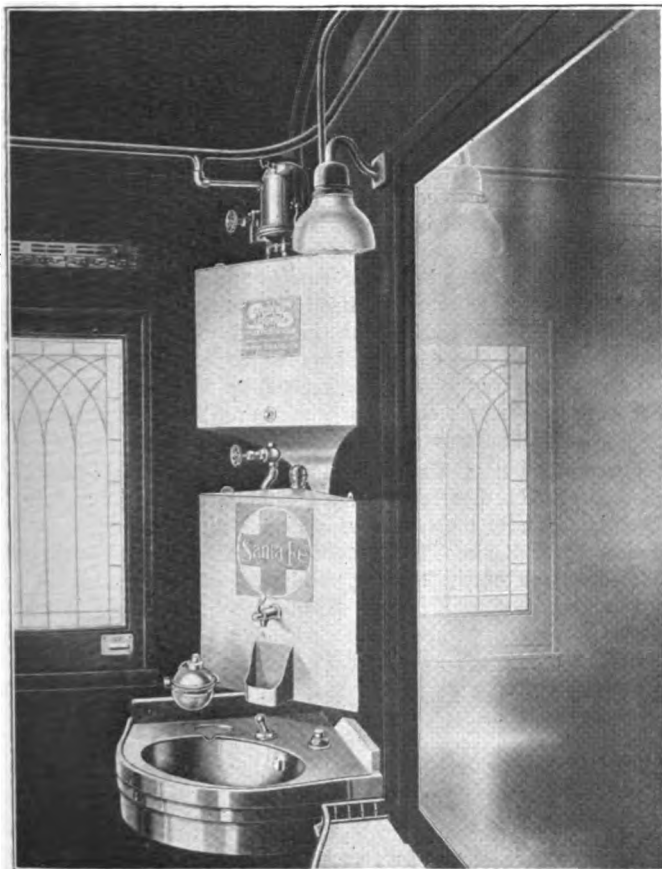

Sanitary Drinking Fountain Applied to a Passenger Car

spection. Water from an overhead tank flows to the filter at the top of the fountain and is filtered through Tripoli rock, then passing to the storage tank directly below. From this tank it passes to the cooling pan in the ice box, which is a small vessel of watertight construction. The ice surrounding the cool-

ing pan lowers the temperature of the drinking water to a desirable degree without permitting any of the ice water to mix with the drinking water.

The metals used in the construction of the fountain are non-corrosive throughout. The filter case is made of galvanized malleable iron and heavy tinned sheet brass. The storage tank and cooler are made of heavy galvanized iron sheets. The cooling pan is made of galvanized gray iron. All the pipes and fittings are also galvanized and the parts exposed to view are finished in German silver. The filter is in the shape of a cylinder with its core removed; the water seeps through from the outside to the inside and passes directly to the storage tank. The filter material does not absorb the impurities of the water, and may readily be cleaned by scrubbing in water with a stiff brush. It may be removed and cleaned in about five minutes and should be cleaned every few days.

Aside from its sanitary characteristics, the principal features of this drinking fountain are the cheap grade and small quantity of ice that may be used. Comparative tests between this and an ordinary water cooler in passenger cars between Chicago and Kansas City showed a saving of 73.6 per cent in the amount of ice used and 80 per cent in the cost of the ice in favor of the sanitary fountain, the temperature of the drinking water averaging 49 deg. for the sanitary fountain and 38 deg. for the ordinary water cooler. Less care is required in the maintenance of this cooler than of the ordinary cooler, a general cleaning being necessary only when the cars are shopped. Provision is made for draining the entire system when the car is out of service and without heat in cold weather.

CHASER GRINDER

A machine for grinding thread cutting dies, especially designed to meet the requirements of users of dies made by the Landis Machine Company, Waynesboro, Pa., has recently been brought out by that company. The machine is of a duplex na-

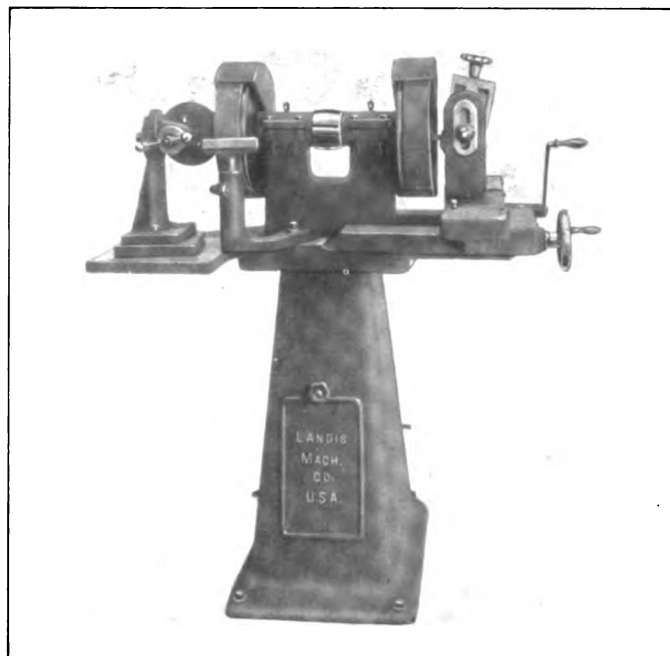

Chaser Grinder and Disc Sharpener for the Cutters of Roller Pipe Cutting Machines

ture, one side being fitted with an attachment for handling all sizes of Landis chasers and the other with a device to sharpen the disc cutters of roller pipe cutting machines. It may also be used to grind tools, for lathes, planers, shapers, etc.

The chaser grinding attachment has adjustment in both hori-

zontal and vertical planes with suitable graduations for controlling the lead and rake angles of the dies. Both the transverse and longitudinal feeds are in horizontal planes, a feature which insures accurate grinding. The table is gibbed at both slides and furnished with an overhang to protect the guides from emery dust. The disc cutter grinding attachment is operated by hand and has both vertical and horizontal adjustments. An adjustable rest is also provided to facilitate the handling of miscellaneous tools.

AUTOMATIC FACING TOOL

The facing of bosses and other similar work with the ordinary flat spot facing tool has always been a troublesome operation owing to the difficulty of getting the tool properly started into the work. The cutting edge of the tool is usually ruined in scraping off the scale so that it must be either reground or replaced by a sharp tool before the operation can be completed. A facing tool designed to overcome these difficulties has recently been introduced by the Mummert-Dixon Company, Hanover, Pa. This tool is provided with a Morse taper shank and is readily applied to a drilling machine spindle whenever work of this kind is to be done.

By referring to the illustration it will be seen that the tool takes an ordinary lathe tool bit, which has a radial movement from the center outward controlled by means of a feed screw. The operation is therefore the same as facing on a lathe. The tool gets beneath the scale at the start and breaks it away as it is fed across the work. The feed is effected by means of the

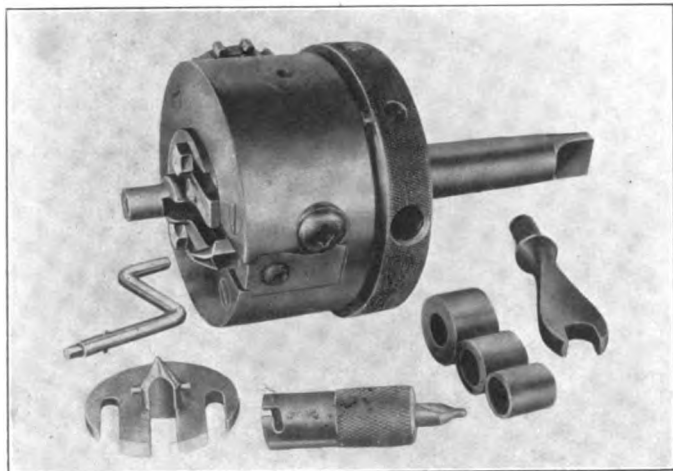

Facing Tool for Drill or Milling Machine

knurled ring on the upper face of the tool, which is either gripped with the hand or held by means of a pin inserted in one of the holes in the knurled edge, and placed against the frame of the machine. The pilot fixture attached to the bottom face of the tool is designed to enter the hole in the center of the boss and steady the tool. Thimbles of various sizes may be placed on the pilot spindle in order that it may be used in holes of any size. In case there is no hole in the boss when the facing is done the cone center and drill pilot may be used. After the work has been centered the drill attachment is removed and the tool steadied by means of the cone center. When the tool is used on a boring mill or other machines with rigid spindles, the use of either guide is unnecessary.

This tool is claimed to increase the rapidity with which work of this kind may be done. The tool bit may be readily removed for sharpening and replaced by another with no more trouble than is required to remove the bit from an ordinary lathe tool. The Morse taper shank is furnished in three standard sizes to fit any drill spindle. The tool is made in 4-in. and 6-in. sizes, indicating the maximum diameter which it will face.

EYE PROTECTORS FOR MACHINISTS AND GRINDERS

A goggle especially designed to meet the requirements of machinists and grinders has recently been placed on the market by T. A. Willson & Co., Inc., Reading, Pa., in the construction of which considerable attention has been given to comfort as well as to eye protection. By the use of a special frame design, the weight is made very light without sacrificing the ability to withstand rough usage in the shop. An adjustable bridge enables the wearer to easily fit the goggles to his face. This bridge is pliable, strong and securely attached to the eye wire. The bridge does not touch the top of the nose at all, but the weight of the glasses is distributed over the sides of the nose and cheeks. This construction makes it possible for the goggles to be worn over other glasses.

It is of the greatest importance that grinders and machinists be protected from emery dust and grit which whirl around the sides of glasses. The light fine-mesh wire sides of these goggles, it is claimed, give complete protection at the sides without being uncomfortable to the wearer. Comfort is further assured by the flexible half cable temples, which easily conform to any face and do not pull or cut into the ears. A fine quality glass is used to insure freedom from eye strain, and lenses may be easily and quickly replaced by simply loosening one of the screws of the end-piece. Being made entirely of rust-proof metal, the goggle is perfectly sanitary and can be thoroughly sterilized at any time.

Several types of goggles are included in the line being placed on the market by this company, each designed to meet the requirements of a certain class of service. For chipping, a frame is used which is especially adapted to prevent glass flying inward should a lens be broken.

STRENGTH OF BALL BEARINGS.—In an accident due to high water the car lighting dynamo of a Santa Fe combination coach and mail car was badly damaged, the armature shaft, which was 1½ in. forged steel, being bent and the dynamo pulley entirely broken up. The dynamo was a Bliss type O, equipped with two No. 412 S. K. F. ball bearings. The dynamo suspension and the generator frame were both badly sprung, the latter being sufficiently out of round so that two of the pole faces bound on the armature. The armature itself was not injured, but the force which caused the bending of the shaft was great enough to break up both the end housings which enclose the bearings. The bearings themselves, which acted as fulcrums, over which the shaft was bent, were entirely uninjured and will be returned to service without any repairs.

BRONZE JOURNAL BEARING.—The American Metal Company, Pittsburgh, Pa., has recent tested a 22-lb. bronze journal bearing placed under the tender of a Pacific type locomotive on the Baltimore & Ohio. This engine ran 51,000 miles with only 1/32 in. wear of the bearing, while the other bearings on the tender were rebabbitted six times each. The composition of these bearings is 65 per cent copper, 30 per cent lead and 5 per cent tin; they are heat treated in crucibles and are solid bronze castings, requiring no babbitt surface. An extreme test of this metal was made under a rolling table of a 108 in. plate mill at the Jones, Laughlin Steel Company's plant at Pittsburgh. The minimum weight on these bearings was estimated at 10,000 lb. Two 75-lb. brasses gave continuous service for four weeks, or twice as long as the ordinary phosphor bronze bearing, and on account of the position of the bearings it was impossible to lubricate them during the test. The graphite in the lead acts as a lubricant and thus reduces the amount of lubricant required.

GRINDING WHEELS.—In many cases, as a grinding wheel wears down the speed of the wheel is allowed to diminish. When this is the case the grain depth of cut will be increased on account of the diminished wheel speed, as well as because of the smaller wheel.—*American Machinist.*

NEWS DEPARTMENT

The large roundhouse of the Duluth, Winnipeg & Pacific at Duluth, Minn., was destroyed by fire December 25. Several locomotives were damaged.

The shops of the St. Louis, Iron Mountain & Southern at Argenta, Ark., which were closed recently were reopened on December 1, 1914, putting 600 men back at work.

The Baltimore & Ohio Chicago terminal repair shop at East Chicago, Ind., was seriously damaged by fire recently. Some damage was also done to the cars in the shop.

The Southern Pacific Co. issued an order effective December 21, 1914, calling back to work 1,600 men who were laid off at the Los Angeles shops during the latter part of October.

The safety supervisor of the El Paso & Southwestern announces that the number of employees injured during the month of October, 1914, was less than half the number reported in October, 1913.

President Kenly, of the Atlantic Coast Line, announces that reductions of from 6 per cent to 10 per cent have been made in the salaries of all persons in the employ of the company receiving \$200 or more a month.

Forty or more railroad employees arrested recently at Pinner's Point (Norfolk) Va., for working at the freight station on Sunday, were fined five dollars apiece. The Southern Railway, acting in behalf of its employees, appealed the case to the Norfolk County Circuit Court.

The safety and efficiency bureau of the San Pedro, Los Angeles & Salt Lake reports a reduction of 33.9 per cent in the number of injuries to employees for the year ending October 31, 1914, as compared with the preceding year. Three employees were killed, the lowest record in the history of the road, except that for 1909, when three were killed.

The new car shops for the Chicago & Eastern Illinois at Oak Lawn, near Danville, Ill., adjoining the locomotive repair shops, were completed December 1, and the new building was put into use at once. At the same time the old shops, which had been closed for some time, resumed operations with a full force working 40 hours a week.

In the yard of the Boston & Maine at Somerville (Boston) Mass., about 2 o'clock in the morning of December 17 last, the police took into custody 118 tramps, who were found in passenger cars, where they had expected to spend the night in the comfortable atmosphere of the cars, which were being kept warm for use early the next morning. On being searched at the police station, not a cent of money was found among the whole crowd.

The Bureau of Mines, of the Interior Department, has eight mine-rescue cars traveling through the different mining districts, giving instructions to miners in rescue, first aid and safety methods. The bureau also has five mine-rescue stations in different coal fields from which it is carrying on similar work. Legislation now pending in Congress will, if enacted, provide for continuous operation of cars throughout the year. Most of the railroads haul the cars free.

At the evening session of the annual meeting of the American Society of Mechanical Engineers in New York, December 2, 1914, the John Fritz Medal was awarded to Prof. John E. Sweet, honorary member and past president of the society, "for his achievements in machine design and for his pioneer work in applying sound engineering principles to the con-

struction of the high speed steam engine." This medal is awarded by the four national engineering societies.

Work was resumed on December 1, 1914, at the shops of the Wheeling & Lake Erie at Brewster, Ohio, and Ironville, in compliance with an order by Judge John H. Clarke, of Cleveland, to the receiver of the railroad. The shops had been practically idle for two months and repairs to cars had been reduced for reasons of economy in order to meet certain interest payments. This policy the court criticized, as neither wise from an economical standpoint nor just from a social point of view.

Although it was reported recently that the members of the shop craft unions had voted to call off the strike which was declared in September, 1911, on the Illinois Central and the Harriman lines, announcement has since been made by the railway department of the American Federation of Labor that the boilermakers voted in favor of calling off the strike, but that their vote was not large enough to offset the vote of the machinists, blacksmiths, car men and sheet metal workers.

The Brotherhood of Railroad Trainmen has filed a statement with the Missouri recorder showing that a total of \$16,056 was expended in the campaign for the passage of the full crew bill, which was defeated by referendum vote at the election on November 3, 1914. The Missouri Legislative Committee of the brotherhood, according to the statement, collected \$15,880, leaving a deficit of \$176. It is stated that the members of the Brotherhood of Railroad Trainmen contributed \$14,680 and that \$1,200 was contributed by the Order of Railway Conductors.

Mr. Love, chairman of the Oklahoma Corporation Commission, is reported as proposing to ask each high school and higher educational institution of the state to offer, as a part of its course of study, instruction in the making and adjustment of freight rates. He wants to give the next generation in Oklahoma a general knowledge of railroad rates, their application and adjustment, which, he says, are all Greek to the average citizen. Mr. Love must be of an optimistic temperament. If he really wishes success he should begin by giving the boys a couple of years of real Greek, as a preliminary training.

The Baltimore & Ohio recently sent four superintendents on a trip of inspection to the Pacific coast, to be gone ten days; and on the return of the party, four other superintendents will be sent on a similar journey but by a different route. The men going on the first trip are H. B. Voorhees, G. D. Brooke, J. C. Hagerty and E. W. Scheer; and those on the second trip, R. N. Begien, F. B. Mitchell, E. T. White and M. V. Hynes. It is expected that all the general and division superintendents of the company will make trips of this kind, occasion being taken to send them now while business is below normal.

The executive committee of the Chicago Association of Commerce has adopted a resolution in favor of setting the clocks throughout the nation ahead one hour in order to secure more daylight after working hours in the summer months. The resolution also asked the United States Chamber of Commerce to consider the question at its annual meeting in February, in Washington, with the idea of bringing about a nation-wide movement in favor of the change. A special committee of the association held a meeting last week to consider a plan for adopting Eastern time for Chicago in-

stead of Central, but so much opposition was expressed by railroad men present, on account of the confusion which would result if Chicago made the change, that it was decided to push the movement along national lines.

The Nashville, Chattanooga & St. Louis has recently placed orders for additional machinery to be used in the equipment and enlargement of its shops at Nashville so that 1,000 freight cars may be built by the company annually. The impelling motive in this decision on the part of president John Howe Peyton and general manager D. B. Carson was not alone the economy, but in order that employment might be given to some of the old and efficient employees of the company and that the unemployed in this section might have an opportunity to secure work. It is estimated that between 400 and 500 additional men will be used in the car-building department of the road and that work will begin early this year. The new equipment necessary will cost \$30,000 and the shops will be rearranged and thoroughly modernized.

The House Committee, at Washington, has reported the Post office appropriation bill for the next fiscal year, with a rider in which are embodied the provisions of the Moon bill for changing the basis of railway mail pay; and Mr. Peters, the chairman of the Railways' Committee, says that an attempt is being made to secure from the Rules Committee a rule to facilitate the passage of the proposed new legislation. Mr. Peters reiterates his declaration that the provision of the Moon bill for payment to the railways on the basis of space occupied is not only unfair in principle, but embodies rates per mile very much too low. With the space in a car fully loaded, the compensation would amount in many cases, to less per ton per mile than ordinary rates for the transportation of coarse commodities by freight train. The railroads are now losing not less than eight millions annually because of the parcel post, and if the space rates are adopted this loss will be still greater. The small railroads, which are now the worst sufferers from inequitable rates, would lose from 25 per cent to 65 per cent additional if the plan should be adopted.

CORRECTION

In the article in the December, 1914, issue, page 614, describing the Chesapeake & Ohio Pacific type locomotives, reference was omitted, through an accident, to the fact that the locomotives are equipped with the type C Street stoker manufactured by the Locomotive Stoker Company, Schenectady, N. Y.

INTERNATIONAL RAILWAY CONGRESS POSTPONED

Word has been received from Berlin that because of the war all preparations have been broken off for the ninth session of the International Railway Congress, which was to have been held there next June. The congress, whose membership consists of governments and companies operating more than half of the earth's railway mileage, is perhaps the most important railroad association in the world. Its sessions are held every five years, the last having occurred at Berne, Switzerland, in 1910. They are devoted to the discussion and interchange of ideas on questions of railway maintenance, equipment and oper-

ation. The German government was to have acted as host, and it was understood that Kaiser Wilhelm would have opened the convention. Some of the American "reporters" have already prepared their papers for the congress.

SUPPLYMEN'S GIFTS DISAPPROVED

President Ripley, of the Atchison, Topeka & Santa Fe, published in the December issue of the Santa Fe Magazine the following letter addressed to all employees:

"Most individuals and companies dealing in railroad supplies have given up the practice of sending Christmas presents to railroad employees and officials. However, to a certain extent the practice was in evidence last year. I have always been opposed to this practice, have discouraged it, and am glad that it is decreasing. I want Santa Fe men to take such action as seems proper to eliminate it entirely. I appreciate that many of the presents given are tokens of friendship extending over many years; nevertheless the practice is bad, and certainly so where the presents have any value. The high standing enjoyed by Santa Fe men makes it all the more desirable that the practice cease."

RESEARCH FELLOWSHIPS AT UNIVERSITY OF ILLINOIS

The engineering experiment station of the University of Illinois announces that four vacancies will be filled at the close of the current academic year in the research fellowships, ten of which have been maintained since 1907. These fellowships, each of which carries an annual stipend of \$500, are open to graduates of approved universities and technical schools, appointment being made for two consecutive collegiate years. Not more than half the time of a research fellow is required for the work to which he is assigned, the remainder being available for graduate study, and at the end of the two years, if all requirements have been met, the master's degree is granted. The subjects covered in this research work include architecture, chemistry, civil engineering, electrical engineering, mechanical engineering, mining engineering, municipal and sanitary engineering, physics, railway engineering and theoretical and applied mechanics. Nominations to these fellowships are based on character, scholastic attainment and promise of success, preference being given to applicants who have had some practical engineering experience since completing their undergraduate work. Applications for nomination must be received by the Director, Engineering Experiment Station, University of Illinois, Urbana, Ill., not later than February 1.

MEETINGS AND CONVENTIONS

International Railway General Foremen's Association.—At a recent meeting of the executive committee of the International Railway General Foremen's Association, it was decided to hold the 1915 convention at Hotel Sherman, Chicago, July 13-16, inclusive.

International Engineering Congress.—Some confusion seems to have arisen between the International Electrical Congress, which it was proposed to hold in San Francisco in September, 1915, and the International Engineering Congress, which, as

RAILROAD CLUB MEETINGS

Club	Next Meeting	Title of Paper	Author	Secretary	Address
Canadian	Jan. 12	Preventing Damage to Freight	Various authors	James Powell	St. Lambert, Que.
Central	Jan. 8	Electric Railway Night		Harry D. Vought	95 Liberty St., New York.
New England	Jan. 12	Making Friends	R. V. Wright	Wm. Cade, Jr.	683 Atlantic Ave., Boston, Mass.
New York	Jan. 15	Practical Methods of Tonnage Rating	J. M. Daly	Harry D. Vought	95 Liberty St., New York.
Pittsburgh	Jan. 23	Prime Movers	H. P. Herr	J. B. Anderson	207 Penn. Station, Pittsburgh, Pa.
Richmond	Jan. 11	General Electric Electric Cars	J. F. Layng	F. O. Robinson	C. & O. Ry., Richmond, Va.
St. Louis	Jan. 8			B. W. Frauenthal	Union Station, St. Louis, Mo.
South'n & S'w'n	Jan. 21	Electric Welding		A. J. Merrill	218 Grand Bldg., Atlanta, Ga.
Western	Jan. 19	Economies in Freight Car Repairs	H. H. Harvey	Jos. W. Taylor	1112 Karpen Bldg., Chicago, Ill.

previously announced in these columns, is to be held during the same month. Owing to the unfortunate situation existing abroad, it has been decided by the governing body of the American Institute of Electrical Engineers to indefinitely postpone the holding of the Electrical Congress. This does not affect the International Engineering Congress, which is to be held as originally planned.

American Society of Mechanical Engineers.—At the annual meeting of the American Society of Mechanical Engineers, held in New York, December 1-4, John A. Brashear, Pittsburgh, Pa., was elected president, and Henry Hess, of Philadelphia, Pa., George W. Dickie, New York Shipbuilding Company, Camden, N. J., and James E. Sague, Poughkeepsie, N. Y., were elected vice-presidents. Charles T. Main, Winchester, Mass., Spencer Miller, The Lidgerwood Manufacturing Company, New York, and Max Toltz, St. Paul, Minn., were elected managers. Morris L. Cooke, Philadelphia, was elected manager to fill an unexpired term, and William H. Wiley was elected treasurer.

American Society of Mechanical Engineers.—The second meeting of the season of 1914-15 of the Chicago Section of the American Society of Mechanical Engineers will be held in the La Salle Hotel, Chicago, January 8, 1915. The following papers will be presented:—Locomotive Superheaters, by R. M. Ostermann, assistant to the vice-president, Locomotive Superheater Company; Locomotive Stokers, by Clement F. Street, vice-president, Locomotive Stoker Company, and Railway Economics, by Willard A. Smith, president, Railway Review. The first two papers will be discussed by Robert Quayle, general superintendent of motive power and car departments, Chicago & North Western; H. T. Bentley, superintendent of motive power, Chicago & North Western; D. F. Crawford, general superintendent of motive power, Pennsylvania Lines West, and Dr. W. F. M. Goss, past-president of the society and chief engineer of the Chicago Association of Commerce Committee on Smoke Abatement and Electrification. The last paper will be discussed by H. H. Vaughan, assistant to the vice-president, Canadian Pacific, and W. H. Marshall, president, American Locomotive Company.

All members of the Western Railway Club are invited to attend and all persons desiring to attend the dinner at 6.30 p. m. should notify the secretary, H. M. Montgomery, 316 Home Insurance building, Chicago, immediately. Those wishing to attend the reading of the papers only will be admitted at 8 p. m. The dinner will be served at \$1.50 per person.

The following list gives names of secretaries, dates of next or regular meetings, and places of meeting of mechanical associations.

- AIR BRAKE ASSOCIATION.—F. M. Nellis, 53 State St., Boston, Mass. Convention, May 5-7, 1915, Hotel Sherman, Chicago.
- AMERICAN RAILWAY MASTER MECHANICS' ASSOCIATION.—J. W. Taylor, Karpen building, Chicago. Convention, June 9-11, 1915, Atlantic City, N. J.
- AMERICAN RAILWAY TOOL FOREMEN'S ASSOCIATION.—Owen D. Kinsey, Illinois Central, Chicago. Convention, July 1915, Chicago.
- AMERICAN SOCIETY FOR TESTING MATERIALS.—Prof. E. Marburg, University of Pennsylvania, Philadelphia, Pa.
- AMERICAN SOCIETY OF MECHANICAL ENGINEERS.—Calvin W. Rice, 29 W. Thirty-ninth street, New York.
- CAR FOREMEN'S ASSOCIATION OF CHICAGO.—Aaron Kline, 841 North Fiftieth Court, Chicago; 2d Monday in month, except July and August, Lytton building, Chicago.
- CHIEF INTERCHANGE CAR INSPECTORS' AND CAR FOREMEN'S ASSOCIATION.—S. Skidmore, 946 Richmond street, Cincinnati, Ohio.
- INTERNATIONAL RAILWAY FUEL ASSOCIATION.—C. G. Hall, 922 McCormick building, Chicago. Convention, May 17-20, 1915, Chicago.
- INTERNATIONAL RAILWAY GENERAL FOREMEN'S ASSOCIATION.—William Hall, 1126 W. Broadway, Wilona, Minn. Convention, July 13-16, 1915, Hotel Sherman, Chicago.
- INTERNATIONAL RAILROAD MASTER BLACKSMITHS' ASSOCIATION.—A. L. Woodworth, Lima, Ohio. Convention, August 17, 1915, Philadelphia, Pa.
- MASTER BOILER MAKERS' ASSOCIATION.—Harry D. Vought, 95 Liberty street, New York. Convention, May 26-28, 1915, Chicago, Ill.
- MASTER CAR BUILDERS' ASSOCIATION.—J. W. Taylor, Karpen building, Chicago. Convention, June 14-16, 1915, Atlantic City, N. J.
- MASTER CAR AND LOCOMOTIVE PAINTERS' ASSOC. OF U. S. AND CANADA.—A. P. Danc, B. & M., Reading, Mass. Convention, September, 14-17, 1915, Detroit, Mich.
- NIAGARA FRONTIER CAR MEN'S ASSOCIATION.—E. Frankenberger, 623 Brisbane building, Buffalo, N. Y. Meetings monthly.
- RAILWAY STOREKEEPERS' ASSOCIATION.—J. P. Murphy, Box C, Collinwood, Ohio. Convention, May 17-19, 1915, Hotel Sherman, Chicago.
- TRAVELING ENGINEERS' ASSOCIATION.—W. O. Thompson, N. Y. C. & H. R., East Buffalo, N. Y. Convention, September 1915, Chicago, Ill.

PERSONALS

It is our desire to make these columns cover as completely as possible all the changes that take place in the mechanical departments of the railways of this country, and we shall greatly appreciate any assistance that our readers may give us in helping to bring this about.

GENERAL

T. U. BROWN has been appointed supervisor of locomotive operation on the lines north and west of Columbia of the Seaboard Air Line, with headquarters at Hamlet, N. C.

W. GILLESPIE, master car builder of the Central Vermont at St. Albans, Vt., has been appointed mechanical superintendent in charge of motive power and car departments, and the position of master car builder has been abolished.

H. C. OVIATT, whose appointment as assistant mechanical superintendent of the New York, New Haven & Hartford, in charge of the newly established bureau of fuel economy, with



H. C. Oviatt

headquarters at New Haven, Conn., has already been announced in these columns, was born on December 5, 1871, at Milford, Conn., and was educated in the grammar school of his native town. He began railway work on May 23, 1889, as a locomotive fireman on the New York, New Haven & Hartford. In July, 1894, he was promoted to locomotive engineman, and in February, 1900, was appointed air brake inspector. Three years later, he was appointed foreman of engines, and in August, 1904, was promoted to master mechanic on the same road. He subsequently served as general inspector of the mechanical department, and in May, 1913, was appointed assistant mechanical superintendent. The following September, he was appointed superintendent of the Old Colony division, which position he held until November 9, 1914, when he was appointed to his present position.

C. H. SEABROOK, superintendent of machinery of the International & Great Northern, with headquarters at Palestine, Tex., has resigned, effective January 1.

IRWIN A. SEIDERS has been appointed fuel inspector, a position recently created by the Philadelphia & Reading, with headquarters at Reading, Pa. Mr. Seiders has been continuously in the service of the Philadelphia & Reading for 33 years, having entered the Tamaqua shops as a laborer early in the year 1882. He served in various capacities in the shop, station and train service until September, 1888, when he entered the engine service as fireman. He was made road foreman of engines in April, 1907, in which capacity he served until his recent appointment as fuel inspector.

S. S. STIFFEY has resigned as superintendent of motive power of the Toledo & Ohio Central and the Zanesville & Western, and that office has been abolished.

T. A. SUMMERSKILL, superintendent of motive power of the Central Vermont at St. Albans, Vt., has been assigned to other duties and the office of superintendent of motive power has been abolished.

MASTER MECHANICS AND ROAD FOREMEN OF ENGINES

N. M. BARKER has been appointed master mechanic in charge of locomotive, car and supply departments of the Copper Range Railroad, at Houghton, Mich., succeeding John A. Berg, assigned to other duties.

J. R. BISSETT has been appointed road foreman of engines of the South Carolina division of the Seaboard Air Line at Savannah, Ga., and the River Junction Line, formerly under the supervision of the road foreman of engines of the Florida division, is now under the supervision of Mr. Bissett.

J. A. CASSADY, master mechanic of the Alabama Great Southern at Birmingham, Ala., has been appointed master mechanic of the Cincinnati, New Orleans & Texas Pacific, at Somerset, Ky., succeeding H. B. Hayes.

J. J. CLARK, formerly general foreman of the Missouri, Kansas & Texas at Walnut Springs, has been made master mechanic at Waco, Texas.

H. CRAMER, road foreman of engines of the Seaboard Air Line at Savannah, Ga., has been appointed supervisor of locomotive operation of the lines south of Columbia, with headquarters at Jacksonville, Fla.

J. E. FITZSIMONS, master mechanic of the Central Vermont at St. Albans, has been assigned to other duties and the position of master mechanic has been abolished.

A. HALLMAN has been made road foreman of engines of the Missouri, Kansas & Texas at Smithville, Tex., succeeding C. E. Stanton.

A. E. HAMLET, road foreman of engines of the North Carolina division of the Seaboard Air Line at Hamlet, N. C., has been transferred to the Alabama division in the same capacity, with headquarters at Americus, Ga.

G. W. HENRY has been appointed assistant road foreman of engines of the Cleveland division of the Baltimore & Ohio at Cleveland, Ohio.

D. W. HIGGINS has been appointed road foreman of engines of the Rock Island Lines at Fairbury, Neb., succeeding W. D. Oakford.

E. J. LANGHURST, assistant road foreman of engines of the New Castle division of the Baltimore & Ohio, has been appointed road foreman of engines at Parkersburg, W. Va.

E. H. McCANN has been appointed master mechanic of the San Antonio, Uvalde & Gulf, with headquarters at Pleasanton, Tex., succeeding J. H. Ruxton, resigned, whose title was superintendent of motive power.

WILLIAM McELRATH has been appointed road foreman of engines of the Rock Island Lines at Eldon, Mo., succeeding J. H. Wood.

W. W. PAYNE has been appointed road foreman of engines of the North Carolina division of the Seaboard Air Line, at Hamlet, N. C.

CAR DEPARTMENT

A. D. BRICE, assistant to the master car builder of the San Antonio, & Aransas Pass, has been appointed master car builder, with headquarters at Yoakum, Tex., succeeding W. T. Cousley, resigned.

WILLIS C. DEMPSTER has been appointed car foreman of the Rock Island Lines at Pratt, Kan., succeeding T. J. Butler.

N. E. HOOKER has been appointed assistant foreman of the car department of the Erie at Cleveland, Ohio, succeeding J. E. Fitzgerald.

C. E. STONE has been appointed general car foreman of the Missouri & North Arkansas, with headquarters at Harrison, Ark.

J. A. WILHITE has been appointed car foreman of the Chicago Great Western at South Des Moines, Ia.

SHOP AND ENGINE HOUSE

LEON ATWELL, roundhouse foreman of the Southern Railway at Birmingham, Ala., has been made general foreman at Selma, Ala., succeeding T. S. Krahenbuld.

J. A. BURTON has been appointed night roundhouse foreman of the Chicago Great Western at South Des Moines, Ia., succeeding George Bailey.

G. A. HILLMAN has been appointed erecting shop foreman of the Erie at Galion, Ohio, succeeding H. A. Kinsey.

W. F. MORAN has been appointed roundhouse foreman of the Rock Island Lines at Shawnee, Okla., succeeding A. Hamilton.

F. K. MOSES, foreman at the Garrett (Ind.) shops of the Baltimore & Ohio, has been appointed master mechanic of the Baltimore & Ohio Chicago Terminal shops, at East Chicago, succeeding J. W. Fogg.

S. E. MUELLER has been appointed general foreman of the Rock Island Lines at Rock Island, Ill., succeeding R. J. McQuade.

BERT SMITH has been appointed general foreman of the Rock Island Lines at Eldon, Mo., succeeding W. H. Burleigh.

J. H. STONE has been appointed boilermaker foreman of the Erie at Marion, Ohio.

F. E. WOLFE has been appointed roundhouse foreman of the Chicago Great Western at Hayfield, Minn., succeeding A. T. Helmbrecht.

PURCHASING AND STOREKEEPING

E. J. BURNS has been appointed storekeeper of the Albuquerque division of the Atchison, Topock & Santa Fe at Winslow, Ariz.

L. C. THOMSON has been appointed general storekeeper of the eastern lines of the Canadian Northern, with headquarters at Toronto, Ont.

ELDRED D. TOYE has been appointed storekeeper of the Ontario Grand division of the Canadian Northern, with headquarters at Toronto, Ont.

OBITUARY

MATTHEW CHARLTON, formerly master mechanic of the Louisville & Nashville Railroad, died of infirmities at his home in Louisville, Ky., on December 25, at the age of 84 years.

COLONEL EDWARD D. MEIER, formerly president of the American Society of Mechanical Engineers, died on December 15 in New York City at the age of 73. He was born in St. Louis, Mo., and graduated from Washington University in 1858. He subsequently spent four years in Germany at the Royal Polytechnic College in Hanover, and later became an apprentice at the Mason Locomotive Works, Taunton, Mass. After serving in the United States army during the civil war he entered the service of the Rogers Locomotive Works at Paterson, N. J. He subsequently was superintendent of machinery of the Kansas Pacific, now a part of the Union Pacific. In 1870 he became chief engineer of the Illinois Patent Coke Company, and two years later was secretary and construction engineer of the Meier Iron Company, and in 1884 organized the Heine Safety Boiler Company, of which he was president at the time of his death. Previous to 1908 he was president of the American Diesel Engine Company and introduced the Diesel motor into this country. He was president of the American Boiler Manufacturers' Association in 1898; president of the American Society of Mechanical Engineers in 1910, and in 1913 represented that society in Munich, at a joint meeting with the German Engineering Society.

SUPPLY TRADE NOTES

The Eddystone plant of the Baldwin Locomotive Works has been put on full time, at least for the next month.

H. R. Sheene has been appointed sales engineer of the Union Switch & Signal Company, with headquarters in room 2039 Railway Exchange building, St. Louis, Mo. Mr. Sheene will report to the resident manager at Chicago.

H. C. Hequembourg, whose election to the vice-presidency of the Standard Chemical Company, Pittsburgh, Pa., has been announced in these columns, was born in St. Louis, Mo. He received his education at Dunkirk, N. Y., and spent the first 21 years of his business life with the Brooks Locomotive Works of that city in the positions, respectively, of bookkeeper, cashier and assistant secretary. When the American Locomotive Company was incorporated in June, 1901, he was made its general purchasing agent, and has remained in that position up to the acceptance of his new appointment. The Standard Chemical Company is a refiner of carnotite ores and produces radium, uranium and vanadium. Mr. Hequembourg as



H. C. Hequembourg

vice-president of the company will be its representative in the east and will have headquarters at 30 Church street, New York. He will also represent the American Vanadium Company in the east.

Alexander Harvey, secretary of the Detrick & Harvey Machine Company, Baltimore, Md., died in that city on November 22, of pneumonia. Mr. Harvey was 57 years old, a native of Baltimore, and with Jacob N. Detrick organized the company bearing his name, in 1884. He leaves three sons and a daughter.

T. A. Willson & Co., Inc., Reading, Pa., has been awarded the grand prize at the Second International Exposition of Safety and Sanitation, held at the Grand Central Palace, New York, from December 12 to 19, 1914. The award was given to the company in recognition of the merits of the various Willson eye protectors.

By a recent decision of the directors of the Pullman Company, the work of building one steel sleeping car a day will continue throughout the winter months. Because of the small demand for cars during the past few months a discontinuance of this policy had been considered, but the recent decision will afford work to the men during the winter.

On December 10, 1914, Judge Hazel, of the Western District of New York, handed down a decision in the suit of the Safety Car Heating & Lighting Company vs. the United States Light & Heating Company, holding patent No. 747,686, issued to J. L. Creveling, and owned by the former company, valid and infringed by the apparatus of the latter company. There were eight claims in the suit and all were sustained. The patent covers regulating devices for regulating the output of a variable speed generator and means for controlling the regulating devices to determine the output.

Arthur E. Jackman has been appointed manager of the machinery department of the Walter A. Zelnicker Supply Com-

pany, St. Louis, Mo., succeeding J. J. Hilpirt, who has resigned to become storekeeper of Cia. Mexicana De Petroleo, "El Aguila" S. A. at Tampico, Mex. Mr. Jackman was at one time general manager of the Sea View Railroad and the Narragansett Pier Electric Light & Power Company. He was also for years in the railway and lighting department of the Westinghouse Electric & Manufacturing Company, and left the position of superintendent of the East St. Louis, Columbia & Waterloo Railway to assume his present duties.

The fire that destroyed part of the Edison Phonograph Works, at Orange, N. J., on December 9, did not in any way affect the Edison Storage Battery Company. One end of the large concrete buildings of the battery works is across the street from Mr. Edison's private laboratory, which was saved, and this as well as the rest of the plant escaped unscorched. The fire started about 5:20 in the afternoon and was under control by 10 o'clock. The telephone exchange was in one of the burned buildings, but through the prompt action of the New York Telephone Company a temporary switchboard was working in the battery office before business hours the next morning and the Public Service Electric Company had emergency lines furnishing power nearly as soon. The business of the Edison Storage Battery Company, therefore, suffered no interruption whatever.

Eli Stillson Hart, chairman of the board of the Rodger Ballast Car Company, Chicago, and one of Chicago's oldest residents, died at his home, 2922 Prairie avenue, on November 23, after

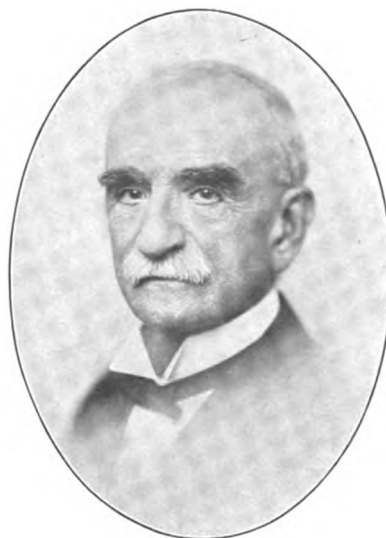

Copyright by Moffett, Chicago.

Eli S. Hart

an illness of several weeks. Mr. Hart was born in Rochester, N. Y., in 1832. In 1855 he was graduated from Hamilton College in the law school. He began the practice of law in Clinton, Ia., and came to Chicago in 1856, where he continued his law practice as a member of a leading firm of that period. In 1874, owing to ill health, Mr. Hart gave up his legal work to engage in business. He was one of the founders of the Rodger Ballast Car Company, the success of which was due to his ability, and until his death he was

chairman of board of directors. Mr. Hart's integrity of character, sound judgment and kindly humor made him many friends. He is survived by three children: Miss Gertrude W. Hart, H. Stillson Hart and Mrs. Evan A. Evans.

William F. Bauer, assistant manager of the railway department of the Edison Storage Battery Company, Orange, N. J., has been appointed manager of the Chicago office of that company, succeeding Charles B. Frayer, who retired on November 30 to devote himself to private interests. Mr. Bauer has been engaged in storage battery work for many years. In 1889 he was the electrician in charge of the original train lighting equipment of the Pennsylvania's Chicago Limited, a lighting system designed by his father, then chief electrician of the Pullman Company. He later had experience with the Electric Accumulator Company, the Westinghouse Electric & Manufacturing Company, the Pullman Company and the Wagner Palace Car Company. In 1901 he entered the employ of the Consolidated Railway Electric Lighting & Equip-

ment Company and two years later was appointed chief electrician of the Missouri Pacific, in charge of car lighting. In 1906 Mr. Bauer became sales engineer of the Electric Storage Battery Company. He has been with the Edison Storage Battery Company for about a year and is president of the Railway Electrical Supply Manufacturers' Association.

Charles Arthur Moore, president of Manning, Maxwell & Moore, New York, died of heart disease on board the steamer Rotterdam, on which he was en route for Naples. Aside from his position as president of Manning, Maxwell & Moore, he was president of the Shaw Electric Crane Company, Consolidated Safety Valve Company, Ashcroft Manufacturing Company, Hancock Inspirator Company, Hayden & Derby Manufacturing Company, United Injector Company, and was a director of the Continental Insurance Company, the Liberty National Bank, the American Bank Note Company and the National Machinery Company. Mr. Moore was born in West Sparta, N. Y., in 1845, and was educated in the public and private schools of Rochester, N. Y., and Lynn, Mass. He enlisted in the navy at the outbreak of the civil war and served throughout the war. He then became a salesman in New England, and in 1880 joined the firm of H. S. Manning & Co., of New York, forming the firm of Manning, Maxwell & Moore, manufacturing railroad supplies. In 1905 the business was incorporated and Mr. Moore became president and a controlling owner. Mr. Moore was a member of the Chamber of Commerce, National Civic Federation, New York Board of Trade and Transportation, American Society of Mechanical Engineers, Empire State Society of Sons of Revolution, Ohio Society, St. Andrew's Society, Pilgrims of the United States and Society of Genesee. He was a member of the Automobile Club of America, Army and Navy, Republic, Union League, Lotus, Engineers, New York Railroad, Machinery, Lawyers and Transportation clubs, and the founder and for ten years president of the Montauk Club.



Charles A. Moore

NEW SHOPS

MISSOURI PACIFIC.—This company will build a 10-stall 95-ft. frame engine house at Horace, Kan., to replace the one recently destroyed by fire. The work will be done by company forces.

OREGON-WASHINGTON RAILROAD & NAVIGATION COMPANY.—Work has been begun on the division terminal buildings of this company at Spokane, Wash., which consist of an 11-stall roundhouse, a machine shop, 80 ft. by 120 ft., a power house, 40 ft. by 50 ft., a coaling plant, cinder pit and coach cleaning facilities. The power house will be of concrete construction, and the other buildings will have brick walls and mill constructed frames. Work is being done by company forces and the approximate cost will be \$150,000.

SOUTHERN RAILWAY.—This company has given a contract to the Murphy Construction Company, East St. Louis, Ill., for the construction of an 18-stall roundhouse, machine shop building, store, oil and office building, at Denverside yard, East St. Louis.

CATALOGS

VENTILATED COMMUTATING POLE RAILWAY MOTORS.—The General Electric Company, Schenectady, N. Y., has issued bulletins No. 44,403 and 44,405, describing the company's commutating pole railway motors for 600 volt and 600/1,200 volt service. Both motors are described in considerable detail.

DUST GUARDS.—The National dust guard is the subject of a 12-page booklet issued by the National Railway Equipment Company, Toledo, Ohio. This dust guard is made entirely of steel and fiber and aside from the adjusting clamps consists of but three pieces. It is being tried out on nearly 100 different railroads.

PORTABLE ELECTRIC DRILLS.—Circular E-2, just issued by the Independent Pneumatic Tool Company, Chicago, Ill., deals with the Thor portable electric drills which are manufactured by this company. It contains four pages and includes illustrations and sizes of these tools, as well as tables giving the various characteristics of each.

TORCHES FOR STEEL CAR REPAIRS.—The Mahr Manufacturing Company, Minneapolis, Minn., has issued an illustrated booklet devoted to the Mahr steel car repairing torches. These torches will burn either kerosene or crude oil and are fitted with interchangeable nozzles. They are also made in sizes suitable for boiler shop and other work.

PORTABLE ELECTRIC TOOLS.—A catalog recently issued by the Neil & Smith Electric Tool Company, Cincinnati, Ohio, is devoted to this company's Ideal line of portable electrically-driven tools. The booklet contains 56 pages, thoroughly illustrated and describes a considerable number of types of electric grinders and buffers, drills, screw drivers, etc. Several pages are also devoted to electrically-driven saws and a table of grinding wheel speeds is included.

RATCHET BRAKE LEVER.—A 15-page booklet issued by the Pittsburgh Railway Appliance Company, Farmers Bank building, Pittsburgh, Pa., deals with the Acme ratchet brake lever and contains a number of illustrations showing this type of lever in its different forms and applied to different classes of freight and passenger cars. Illustrations and descriptive matter are also included dealing with the universal journal box lid manufactured by the same company.

PAINT TESTS.—An eight page leaflet has been published by the Joseph Dixon Crucible Company, Jersey City, N. J., as a supplement to the October, 1914, issue of Graphite, which is entitled The Atlantic City Steel-Fence Paint Tests. As the title indicates this pamphlet deals with the final report of inspection of the steel paint test fence which was presented at the meeting of the American Society for Testing Materials, held in Atlantic City in July of this year. A brief history of the test is given, followed by a discussion of the results as reported by the inspection committee.

STEEL PIPE.—History, Characteristics and Advantages of National Pipe is the title of National bulletin No. 11-C issued by the National Tube Company, Pittsburgh, Pa. The second edition, enlarged, was issued in November, 1914. This bulletin is a 48 page booklet and goes into the subject of steel pipe very fully. It is divided into chapters and is thoroughly illustrated. The National Tube Company has also issued recently information regarding the increase in the amount of steel pipe manufactured from 1888 to 1913. In 1888 there were approximately 500 tons of wrought iron pipe manufactured, while the amount of steel pipe manufactured was negligible. In 1905 the amount of wrought iron pipe manufactured had decreased to 452,797 tons while the steel pipe manufactured had increased to 983,198 tons. In 1913 the wrought iron pipe had decreased to 312,746 tons and the steel had increased to 2,189,218 tons.

Railway Age Gazette

MECHANICAL EDITION
INCLUDING THE
AMERICAN ENGINEER

PUBLISHED ON THE FIRST THURSDAY OF EVERY MONTH BY THE
 SIMMONS-BOARDMAN PUBLISHING COMPANY,
 WOOLWORTH BUILDING, NEW YORK, N. Y.

CHICAGO: Transportation Bldg. CLEVELAND: Citizens' Bldg.
 LONDON: Queen Anne's Chambers, Westminster.

EDWARD A. SIMMONS, *President* L. B. SHERMAN, *Vice-President*
 HENRY LEE, *Secretary*

The address of the company is the address of the officers.

ROY V. WRIGHT, *Editor*

R. E. THAYER, *Associate Editor* A. C. LOUDON, *Associate Editor*
 C. B. PECK, *Associate Editor*

Subscriptions, including the eight daily editions of the *Railway Age Gazette* published in June in connection with the annual conventions of the Master Car Builders' and American Railway Master Mechanics' Associations, payable in advance and postage free:

United States, Canada and Mexico..... \$2.00 a year
 Foreign Countries (excepting daily editions).... 3.00 a year
 Single Copy 20 cents

Entered at the Post Office at New York, N. Y., as mail matter of the second class.

WE GUARANTEE, that of this issue 4,800 copies were printed; that of these 4,800 copies 4,122 were mailed to regular paid subscribers, 250 were provided for counter and news companies' sales, 204 were mailed to advertisers, exchanges and correspondents, and 224 were provided for samples and office use; that the total copies printed this year to date were 9,300, an average of 4,650 copies a month.

The RAILWAY AGE GAZETTE, MECHANICAL EDITION and all other Simmons-Boardman publications are members of the Audit Bureau of Circulations.

VOLUME 89 FEBRUARY, 1915 NUMBER 2

CONTENTS

EDITORIALS:	
Methods of Dealing with Men.....	55
The Training of Foremen.....	55
Car Department Correspondence.....	55
Truss Rods on Steel Sills.....	56
Care of Boilers in Winter.....	56
Western Engineers' and Firemen's Demands.....	56
New Books.....	57
COMMUNICATIONS:	
Tender Derailments.....	58
GENERAL:	
Southern Locomotive Valve Gear.....	59
The Best Methods of Dealing with Men.....	61
Jersey Central Freight Car Repair Shops.....	62
Improved Performance with Old-Time Coaling Facilities.....	66
Japanese Railways Dynamometer Car.....	66
CAR DEPARTMENT:	
Car Control.....	71
Car Department Correspondence and Reports.....	72
Union Pacific Steel Freight Cars.....	73
Steel Frame Box Cars for the Illinois Central.....	78
Defective Box Cars.....	80
SHOP PRACTICE:	
Training Engine House Foremen.....	81
Jig for Drilling Dry Pipe Collars.....	81
Finishing Tank Valve Castings.....	82
Cleaning Air Pumps.....	82
Repairing Locomotive Boiler Tubes.....	83
Engine House Repair Work.....	85
Pneumatic Flue Cutter.....	86
Riveting in Steel Car Construction.....	87
Repairing Worn Tail Braces.....	90
Air Pump Rack.....	90
NEW DEVICES:	
Self-Contained Grinding Machine.....	91
Diaphragm-Operated Triple Valve.....	92
Adjustable Saw Guard.....	95
Side Plate Planer.....	95
Universal Hollow-Hexagon Turret Lathe.....	96
Portable Lathe.....	97
Electric Crane Trolley.....	97
Vacuum Paint Sprayer.....	98
Universal Pipe Joint.....	98
NEWS DEPARTMENT:	
Notes.....	99
Meetings and Conventions.....	100
Personals.....	101
Supply Trade Notes.....	103
Catalogs.....	104

Methods of Dealing With Men

We print elsewhere in this issue an article on the handling of men, by H. E. Gamble, foreman blacksmith of the Pennsylvania Railroad, Altoona, Pa. Mr. Gamble has brought out some important points which should be carefully considered by all foremen. In substance, he advises the foremen to consider the men under them as men, and not as mere machines placed at their disposal and out of whom they are to extract the greatest amount of labor for the least possible cost. That this does not pay has been demonstrated many, many times. Fine, elaborate and extensive systems of shop administration have utterly failed simply because the men on whom the system was supposed to operate were not given proper consideration. The value of the most efficient machine may be entirely lost if the man operating it is not in accord with his superiors. The contented workman is the dividend producer; his energy, mind and thought produce the actual results. The foreman who obtains the most from his men is the one who treats them as men and as he himself would like to be treated. The foreman is directly responsible for the work of his men and they have his reputation in their hands. Is it not logical, therefore, that he should seek to secure their interest and loyalty?

The Training of Foremen

In an editorial on this subject, page 558 of our November, 1914, issue, after outlining the conditions which resulted in the failure of a young man when he had been appointed to the position of engine house foreman, we stated that if the man had had a guiding hand at the terminal during the first few weeks, or even days, after he went there as foreman, he would probably have made good. In commenting on this editorial a correspondent said that it appealed to him particularly because of his own experience; he had been sent to relieve a foreman who left within a few hours after his arrival, giving him almost no opportunity to familiarize himself with conditions before the entire responsibility of the work was placed upon him. This is an example of the haphazard methods commonly employed in the appointment of engine house foremen.

To those who are familiar with the way such appointments are very frequently made, and who have endeavored to devise some means of providing trained men for the position of foreman, the article on Training Engine House Foremen, by R. G. Gilbride, which appears elsewhere in this issue, should appeal particularly. Space does not permit of printing the form of examination which accompanied Mr. Gilbride's article, but it covers the general duties of the various classes of men employed in an engine house in a manner sufficiently thorough to show plainly by the answers a candidate makes to the various questions whether or not he is familiar enough with engine house work in general to undertake the duties of a foreman. This examination could, of course, be varied to suit the conditions on any particular road. If, after serving an apprenticeship, a young man were given this course of training, he should be capable of successfully assuming charge of an engine house, provided care were taken when selecting him as a candidate, to make sure that he possessed the qualifications desirable in an engine house foreman; indeed, if he were to fail after receiving such a training it would seem that it must be because of a lack of some qualification other than training.

Car Department Correspondence

Elsewhere in this issue is published a paper on "Car Department Correspondence and Reports," presented at the January meeting of the Car Foremen's Association of Chicago. Mr. Claudy points out in this paper some of the important items that make unnecessary correspondence. But neither he nor any of the members at the meeting spoke of the lack of familiarity with the M. C. B. Rules that exists among some of the men employed in the car department. Interviews

with mechanical officers who are directly interested in the M. C. B. rules and price list have disclosed the fact that this is a large source of trouble. Incorrect billing is liable to cause more unnecessary correspondence than a wrong car number, for in addition to the letters of exception there may be letters of explanation concerning the point at issue. There may be some excuse for misinterpretations, but there is little excuse for ignorance of the rules. The chief point brought out in the discussion of the paper concerned the delay caused by the undue use of technicalities in endeavoring to avoid responsibility. It should be remembered that the rules were promulgated to aid the roads in maintaining their equipment while on foreign roads. They are designed to provide an easy, fair and uniform method of locating responsibility and making charges for work performed by the handling lines. Their purpose is primarily to save time and money for the roads which are members of the Master Car Builders' Association, and until the different roads and their employees look on the rules in that light and desist from trying to evade responsibility by means of technicalities, or what is sometimes called "sharp practice," the rules will not fully serve the purpose for which they are intended. In the long run there is nothing to be gained in "putting anything over" another road, for with the great amount of interchange between all the roads there is always an opportunity to "get back" and the processes will net both roads a loss, due to unnecessary correspondence and possibly traveling expenses, with absolutely nothing gained.

Truss Rods on Steel Sills

On page 4 of our January issue appeared a communication entitled "Truss Rods on Steel Members," criticising the discussion of this subject which appeared in an editorial on British steel car construction in the October, 1914 issue. There are, no doubt, conditions under which the use of truss rods on steel members may be advisable. But it is a fact that the use of truss rods with the structural steel sections usually employed in steel underframes, the rod being provided with turnbuckle adjustment and passing over queen posts, but not secured to them, not only produces an arrangement the action of which under load is very uncertain, but one which is usually uneconomical from the standpoint of the best distribution of material. Wood sills are always provided with truss rods which are so adjusted that the rod is not only under initial tension but the sill is given a perceptible upward camber, thus insuring the action of the sill as the compression member while the rod takes the tension resulting from the direct loading as well as from the eccentricity of drawbar pull. This adjustment is entirely feasible because of the very low modulus of elasticity of the wood and the relatively large deflection of the sill within its safe working load.

If the wood sill is replaced with one of structural steel, say an eight or ten inch channel, the case is entirely different. The deflection of such a sill within the length of span commonly found in car construction, under a load corresponding to the safe working stress of the material, will never be more than a small fraction of an inch. The effect of this deflection transmitted to a truss rod through the queen posts—assuming the rod to have been originally in perfect adjustment without initial stress—will be to produce a stress equivalent to a lengthening of the rod by an amount much smaller than the deflection of the beam. In other words, the beam may be loaded till the material has reached its safe working stress with but little stress in the truss rod unless the rod is of a size much larger than is usually employed, or is sufficiently tight to produce an initial compression in the sill, the amount of which is always uncertain. Under heavy buffing shocks it may be possible to cause a reversal of stresses in the sill due to the eccentricity of the draft gear, compression in the sill being greatly augmented and tension eliminated from the lower chord. Under such con-

ditions the truss rod is worthless, and may even be detrimental if drawn up tight.

On the whole it may be said that the truss rod is of relatively small value when used in connection with a structural section, the shape of which is especially designed to secure the maximum stiffness per unit of weight. Its use is a makeshift which should find no place in a permanent structure, such as an all-steel or steel underframe car.

Care of Boilers in Winter

This is a time of the year when troubles peculiar to locomotive boilers are aggravated greatly by weather conditions, and although the subject is far from being new it may not be amiss to remind those who have to do with boiler maintenance that great care is necessary both in maintenance and operation if boiler troubles are to be kept within reasonable limits during the winter months. We are further reminded of this by looking over an article on the maintenance of locomotive boilers by J. F. Raps, general boiler inspector of the Illinois Central Railroad, which was published in the Illinois Central Magazine. Many cases of leaky tubes, perhaps the greatest aggravation to boiler maintainers and certainly a cause of many trials to the operating department, are started at the ash pit by careless use of the blower and the injector. A good, instructive, heart-to-heart talk on this subject by the foreman with the ash pit men will do much toward relieving a difficulty of this kind. The cleaning out of tubes is another matter of prime importance. The winter is a season when a locomotive needs every portion of its heating surface, and if tubes are allowed to become stopped up, and the condition is not remedied, the steam-making capacity is reduced. We know of but one way to make sure that a tube is clean; that is to pass an auger completely through it and afterwards blow the tube out with air. There are many boiler makers who make a practice of using a short auger, or else inserting the long auger only a few feet in the tube. The work is then entered in the work book as done and the engineman cannot understand why the locomotive does not improve in steaming and very likely books the steam pipes to be examined or reports a leak in the front end at the other division terminal, when all that is needed is that the tubes be thoroughly cleaned for their entire length. Advantage should be taken of days on which a locomotive is being washed out to see that the tubes are all in good condition, and more than ordinary care should be given to the cooling and washing of the boiler to avoid sudden changes in temperature and the consequent sudden contraction of sheets. If these points are kept carefully in mind in handling locomotives at engine terminals, much needless work can be avoided and many engine failures prevented.

Western Engineers' and Firemen's Demands

It is now about sixteen months since the engineers and firemen of the western roads presented demands for increases in rates of pay and more favorable service rules. There were numerous conferences between the representatives of the men and the railroads affected, but no definite agreement could be reached. Now the arguments are being heard by a board of arbitration appointed under the Newlands act, and the findings of this board will decide the issue. The hearings were begun on November 30, 1914, the enginemen and firemen having the first opportunity for presenting their case.

In brief, the men have demanded that the high rates of pay in effect on some roads that do not have as favorable service rules as other roads, be applied to the favorable service rules that are in effect on roads that do not pay the higher rates, and both rates and rules be applied universally throughout the West. This, it may readily be seen, would be a pyramiding of the cost to the railroads, and in some cases give exorbitant pay to some of the engine crews. As an example, Article 7 of the men's demands requires that engineers and firemen ar-

iving at a terminal or the end of the run shall be automatically released, and when used again shall begin a new day. Taking a specific case under this rule on the Gulf, Colorado & Santa Fe, a certain engineer earned in October, 1913, \$202.74 per month for working 8½ hours per day on a "turn around" run. Under the new rule he would have earned \$1,435.75, and his fireman, \$37.79 for that one month. There are many other cases similar to this and the roads estimate that this rule alone would cause an increase in operating expenses of \$621,128 a year. Another instance of the unreasonableness of some of the demands is the demand that engineers and firemen deadheading on company business shall be paid the same rate and on the same basis as the engineer and fireman running the train on which they are deadheading. This means full time for absolutely no work; the men may even be sleeping in a Pullman or caboose.

The representatives for the railroads began their testimony on January 26. James B. Sheean, counsel for the railroads, stated that a comparison of the wages of the men making the demands with those of any other craft, or of any other railway employees, or of engineers and firemen in other parts of the country, show that they are receiving already a higher compensation in both rates of pay and rules. He also stated that in the wages for about 5,000 typical men in all classes of service for an entire year, there was a maximum of \$3,725.20 for passenger engineers, \$3,342.30 for freight engineers, \$1,752.20 for passenger firemen, and \$1,890.32 for freight firemen. As compared with these, the governors of seven states receive \$3,000 or less per year, while those of seven other states receive \$4,000, or only slightly above the engineers' maximum earnings. For the month in which the demands were presented the engineers in regular passenger service earned from an average of \$185 to a maximum of \$341.60 per month, and in freight service from an average of \$170 to a maximum of \$358.70 per month; firemen in regular passenger service earned from an average of \$115.54 to a maximum of \$209.89 per month, and in freight service from an average of \$110 to a maximum of \$221.05 per month; other firemen in combination freight and passenger service earned even more than this.

The testimony of J. H. Keefe, assistant general manager of the Gulf, Colorado & Santa Fe, for the railroads, shows in considerable detail just what these demands mean in money to the railroads. For the months in which the demands were presented (October, 1913), separate accounts of what the men earned under the present rates of wages and what they would have been paid under the schedule demanded by them were kept by the railroads affected. From these records Mr. Keefe showed that if the demands were granted, approximately \$40,000,000 would be added to the yearly operating expenses of the 98 roads affected. For that specific month the enginemen would have received \$1,759,008 in addition to what they were already paid, and the firemen, \$1,653,391. The total additional compensation to motormen, their helpers, and to the hostlers would amount to \$263,561, making a grand total additional compensation of \$3,675,960. In addition to this \$181,009 would have to be expended for new help, making a total of \$3,856,969. This is an increase of 51 per cent.

The increase for engineers on passenger trains would amount to 37.5 per cent, and for the firemen, 42 per cent. In through freight service the increase for the enginemen would amount to 41.2 per cent, and for the firemen to 25 per cent. In way freight service the increase for the enginemen would be 56 per cent, and for the firemen, 67 per cent. In switching service the increase for the enginemen would be 38 per cent, and for the firemen 51.5 per cent. In other service the increase for the enginemen would be 31 per cent, and for the firemen 35 per cent. Taken as a whole, considering all classes of service, the increases for the enginemen would be 41 per cent, for the firemen 61 per cent, and for the hostlers 108 per cent.

These figures speak for themselves and are especially audible when the present condition of the railways is taken into con-

sideration. Our readers well know to what economies and retrenchments their respective roads have been forced, and the anticipation of still greater sacrifices for the benefit of a selected 7 per cent of all western railway employees, who at present receive over 12 per cent of the wages paid, cannot be viewed with very great enthusiasm. If the demands were granted as presented, this favored 7 per cent would be receiving in the neighborhood of 17 per cent of the wages paid to the railway employees in the western district.

NEW BOOKS

The Influence of Smoke on Health. 173 pages, 6 in. by 9 in. Bound in paper. Published by the University of Pittsburgh, Pittsburgh, Pa.

This is smoke investigation Bulletin No. 9 of the Mellon Institute of Industrial Research and contains the papers representing the work done by the physicians and laboratory investigators on the staff of the smoke investigation. It is edited by Oskar Klotz and William Charles White.

The Origin of Coal. By David White and Reinhardt Thiessen, with a chapter on the Formation of Peat, by Charles A. Davis. 378 pages, 6 in. by 9 in. Illustrated. Bound in paper. Published by the Department of the Interior, Bureau of Mines, Washington, D. C.

This is bulletin No. 38 of the Bureau of Mines and constitutes a report of studies to learn from microscopic examinations of coal how far and in what way the grouping of coal by types depends on differences in the kind of plant material from which it was formed and on the conditions of its accumulation, or how far the special characters or qualities of coal of any type were determined by the nature and the state of the plant debris from which the coal was formed.

Graphic Methods for Presenting Facts. By Willard C. Brinton. 363 pages, 7 in. by 10 in. Fully illustrated. Bound in cloth. Published by the Engineering Magazine Company, 140 Nassau street, New York. Price \$4.

In the preparation of this book it was intended to produce a work which can serve as a handbook for any one who may have occasional charts to prepare for reports, for magazine illustration or for advertising. An effort has been made to present the subject to suit the point of view of the business man, the social worker and the legislator. Mathematics have been entirely eliminated and very few technical terms are used. It is desired to reach those readers who have never had any statistical training, and therefore consistent effort has been made to keep the book on such a plane that it may be found reasonable and useful by any one dealing with the complex facts of business or government. It should also, however, prove of use to engineers and statisticians.

Proceedings of the Traveling Engineers' Association. Compiled and published by W. O. Thompson, secretary of the association, Buffalo, N. Y. 453 pages, 6 in. by 9 in. Bound in leather.

This book is the report of the twenty-second annual convention of the Traveling Engineers' Association, which was held in Chicago, September 15 to 18, 1914. The important subjects considered at this convention and which are included in the report are the Care of Locomotive Brake Equipment, the Economical Operation of Locomotives, and a paper on the Chemistry of Combustion. All the subjects were thoroughly discussed and the information published in these proceedings is of value to railway mechanical men. The paper on the Care of Locomotive Brake Equipment is especially useful as it is in sufficient detail and covers the ground so thoroughly that it may be considered one of the best treatises on this subject ever printed. The proceedings also contain addresses by J. F. DeVoy, of the Chicago, Milwaukee & St. Paul; H. C. Bayless, of the Minneapolis, St. Paul & Sault Ste. Marie, and Frank McManamy, chief inspector of locomotive boilers, Interstate Commerce Commission.

COMMUNICATIONS

TENDER DERAILMENTS

TOPEKA, Kan.

TO THE EDITOR:

Notwithstanding the numerous reports and recommendations that have been made from time to time on the subject of tender derailments, we are confronted with periodical epidemics of this trouble. These cases, as a general thing, cause very little damage, but the danger of a bad accident is great and every means known should be brought to bear on the subject to reduce the tendency. Track conditions are generally blamed for these derailments, but in most cases the trouble can be traced to other causes which, if corrected, will overcome the difficulty.

In one case of an Eight-wheel locomotive, the tender was being derailed entirely too often; and the trouble was completely overcome by changing the location of the side bearings from 66 in. centers to 43 in. centers. This location was determined by first locating the center of gravity of the tender frame, cistern and load, and the combined weight of these parts was considered as acting from this center of gravity. It was also assumed that the forces generated by the weight of the tender and load on an uneven track and around curves acted on a line from this center

ance between the top of the bolster and the bottom of the top arch bar.

In following up another analysis a tendency is found in the truck to lead toward the side having the heaviest load; in other words, the side of the truck having the normal weight from the center plate through the bolster plus the thrust of the side bearing, will not travel as fast with a given pull at the center pin as the side having only the normal weight. This tends to turn the truck horizontally and is resisted by the wheel flanges, and tends to crowd the lead flange of the heavy side of the truck against the rail. If the engine is on a curve and curving to the opposite side from the way the tank is listing, we have the centrifugal force due to the speed of the engine and the above mentioned tendency, both acting to crowd the flange against the outer rail, causing a liability to climb the rail. On the other hand, if the curve leads to the side of the tank that is down, the tendency to turn the truck horizontally is not so detrimental, as it helps to lead the truck around the curve. In this case the centrifugal force due to the speed of the engine tends to crowd the truck toward the outer rail, which in this case is on the light or elevated side of the truck, and it is possible to imagine these wheels lifted enough to climb the rail under the conditions mentioned.

The greatest trouble I believe is due to the location of the side bearings and the lifting tendency produced by a too wide spacing, together with the movement of the tank frame caused by the engine. This latter may tend to throw the front truck toward the side that is raised at the instant it is raised, on account of the rear drivers being on the rebound (after having passed the track depression that is just listing the front tender truck), and causing the lifted flange to drop on top of the rail.

The committee on tender trucks, of the Master Mechanics' Association, reporting in 1909 covered this point in their conclusions as follows:

"We are of the opinion that tender derailments can be practically overcome by the use of properly designed trucks having rigid or swing motion bolsters supported by suitable bolster springs, either elliptical or half elliptical, double or triple, and when side bearings are properly located, having a spacing of 36 in. front, where possible, and 48 to 50 in. at the rear end. The types of truck may be of the arch bar or steel side frame pattern, with journal boxes rigid with the arch bars or side frames; or of the pedestal type having arch bars or solid frames with springs over the journal boxes; or of the pedestal type having side equalizers with half-elliptical springs between the equalizers."

Later experiments with a similar tender that was also giving trouble proved that the Master Mechanics' rule of 36 in. for the front side bearings and 48 in. for the rear was perfectly satisfactory. These figures average 42 in. center to center as against 43 in. determined in the first mentioned case, and no doubt closing the front bearings to 36 in. and spreading the rear to 48 in. is also in line with a further steadying of the tank; at any rate it works out very well in practice.

The subject is one well worth careful attention and these few thoughts, though not new, are brought out again for what they are worth.

G. W. LILLIE,

Dist. Mechanical Superintendent, Chicago, Rock Island & Pacific.

[EDITOR'S NOTE.—The subject of tender derailments was discussed in the Railway Age Gazette during 1912 on pages: 561 and 569, September 27; 667, October 11; 723, October 18; 783, October 25; 874, November 8; 919, November 15; 1130, December 13.]

TENSION ON BRUSHES.—The tension on dynamo brushes should be set by the aid of a small spring balance, so that all the brushes will bear with an equal pressure. This refers especially to high-speed machines; the pressure will vary from about 8 to 10 oz. per sq. in. of brush surface in slow-speed machines up to 1¼ lb. in the high-speed types.—Power.

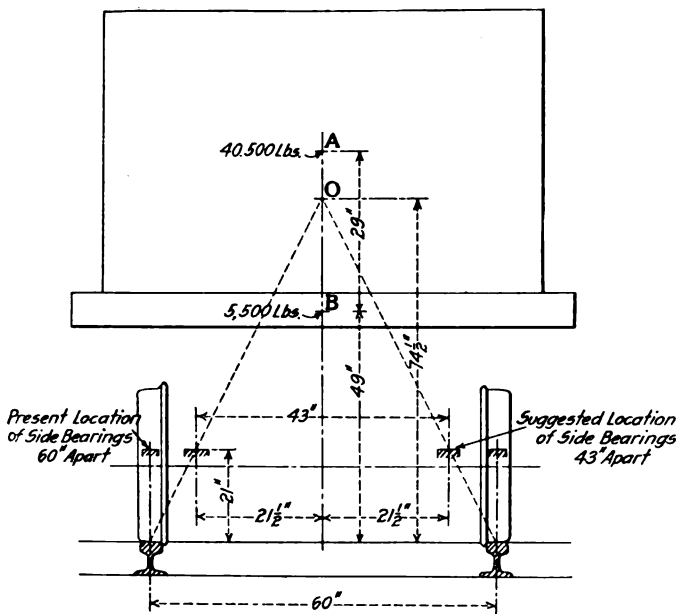

Change in Location of Side Bearings Which Eliminated Tender Derailments

of gravity to the rail. In this case the intersections of these lines with the horizontal line across the top faces of the side bearings were 43 in. apart, and the side bearings were moved in to correspond with this with the best of results.

In my opinion, this location divides the load that is transmitted to the lower side bearing by the upper or body side bearing, by conveying a greater proportion to the opposite truck spring than would be the case with the old location, and also puts the load between the two final points of support, namely the two rails. The farther out the side bearings are placed the greater the proportion of the side bearing load that compresses the springs on this end of the bolster. This tendency is increased by the rebound of the springs at the opposite end of the bolster, from the previous roll of the tank to the opposite side. These forces combine to give a lifting tendency to the opposite or light end of the bolster, and this is greater if the side bearings are located outside the rails, and if the truck springs are too weak and compress solid under the load. This will lift the wheels on the light side of the truck, especially if there is not enough clear-

SOUTHERN LOCOMOTIVE VALVE GEAR

A Description of the Latest Development in Outside Gears, with an Analysis of Its Motion

BY R. S. MOUNCE

The Southern locomotive valve gear is the latest development in outside gears. It is being used to some extent on several railroads and is, apparently, well past the experimental stage. On this account, and also because the gear embodies certain principles not heretofore used in outside valve gear construction, an explanation of its principles and a detailed analysis of its motions will probably be of interest at this time.

In some respects the Southern valve gear resembles other well known types of outside gears:

1. Motion is imparted to the valve by an eccentric crank, attached to the main crank pin, the eccentric crank pin being located approximately 90 deg. from the main crank pin.

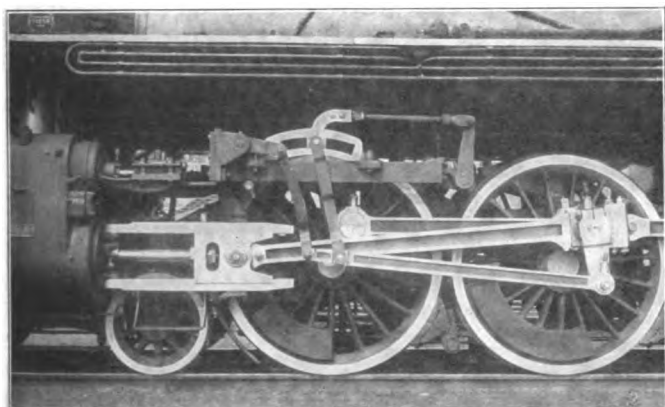

Application of the Southern Valve Gear to a Locomotive With Inside Admission Valves

2. It resembles one other gear in that all the moving parts have pin and bushing connections.

It differs from other outside gears in these respects:

1. The connection between the crosshead and valve rod has been eliminated. The method of obtaining an equivalent movement will be explained further on.

2. It has no oscillating link, and, as a consequence, the wear between the link and the link block, as well as the so-called "slip" of the link block, generally believed to be objectionable, has been eliminated.

3. The links used with the Southern valve gear do not perform the same function as do the oscillating links in other gears. They are stationary and serve only to guide the movement of the point of suspension of the radius hanger, when the reverse lever is moved to adjust the cut-off or to reverse the gear.

4. The small number of parts forming the Southern gear tends to reduce the reciprocating weights. The correspondingly small number of points of wear should make it attractive from a maintenance standpoint, provided the gear remains in reasonably accurate adjustment between shoppings of the locomotives.

ANALYSIS OF THE MOTION

The description to follow refers wholly to the kinematic diagram, which shows the Southern valve gear arranged for inside admission valves. The only change in the arrangement of the parts for outside admission valves is the location of the eccentric crank pin, which is set 90 deg. in advance of the main crank pin instead of 90 deg. behind it, as in the case under consideration.

The crank pin circle is divided into twelve equal parts. Each division is numbered and the corresponding number is

placed on the path of each moving part in order to show its position in relation to the crank pin during one revolution of the drivers in forward motion. The diagram shows the exact path of each part of the gear during one complete cycle in full gear forward motion. The position, No. 1, for which each part is shown by heavy center lines, was chosen because it shows the parts most clearly in their relation to each other.

The motion imparted to the valve, while coming from one source, the return crank, is, in reality, made up of two motions: one, which moves the valve a distance approximately as great as is required for full valve travel, and which may be decreased by "hooking up" the reverse lever; and the other, which moves the valve a distance equal to the total lap plus twice the lead, and which is constant at all times regardless of the position of the reverse lever. The latter motion corresponds to the motion obtained from the crosshead in other types of outside gear. It is obtained in the Southern gear by using the eccentric rod, *ABC*, as a lever. The fulcrum is at *B*, and the distance *1-7*, traced by the point *C* on the ellipses, equals the total lap plus twice the lead. In order to obtain this movement, it is necessary to so proportion the eccentric rod that the lengths *AB* and *BC* are in the same ratio as are the diameter of the return crank circle and the total lap plus twice the lead.

The diagram shows the main crank pin on the front dead center, position *No. 1*. The valve is then displaced $1\frac{5}{32}$ in. ahead of its central position, which means that the front steam port is open $\frac{7}{32}$ in., the amount of the lead. If the crank pin were on the back dead center, position *No. 7*, the valve would be displaced the same distance back of its central position. The ellipses traced by the point *C*, for forward, backward and mid-gear positions of the reverse lever, intersect at two common points, *1* and *7*, which clearly shows the function and operation

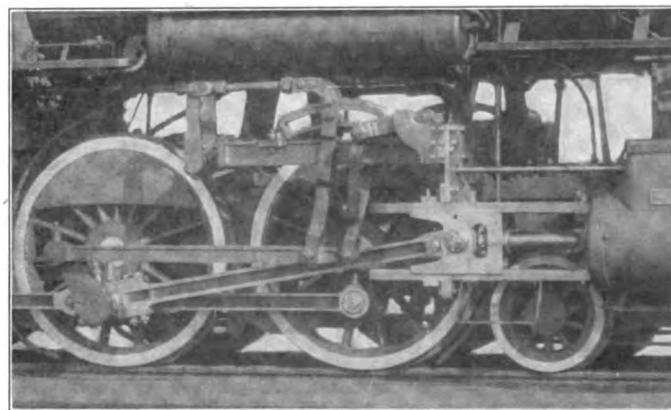

Application of the Southern Valve Gear to a Locomotive With Outside Admission Valves

of the eccentric rod extension, *BC*, and also that the lead is constant at all points of cut-off.

The upper end of the radius hanger, *EB*, is attached to the link block at *E*. The position of the link block is controlled by the reverse lever through the main and auxiliary reach rods. The radius hanger, together with the link, link block, reach rods and reverse lever, comprises the reversing mechanism. The lower end of the radius hanger is constrained to move in an arc of a circle whose center is at *E*. This arc is controlled by the position of the point of suspension. For full gear forward motion the front end of the arc is below the back end, and the vertical

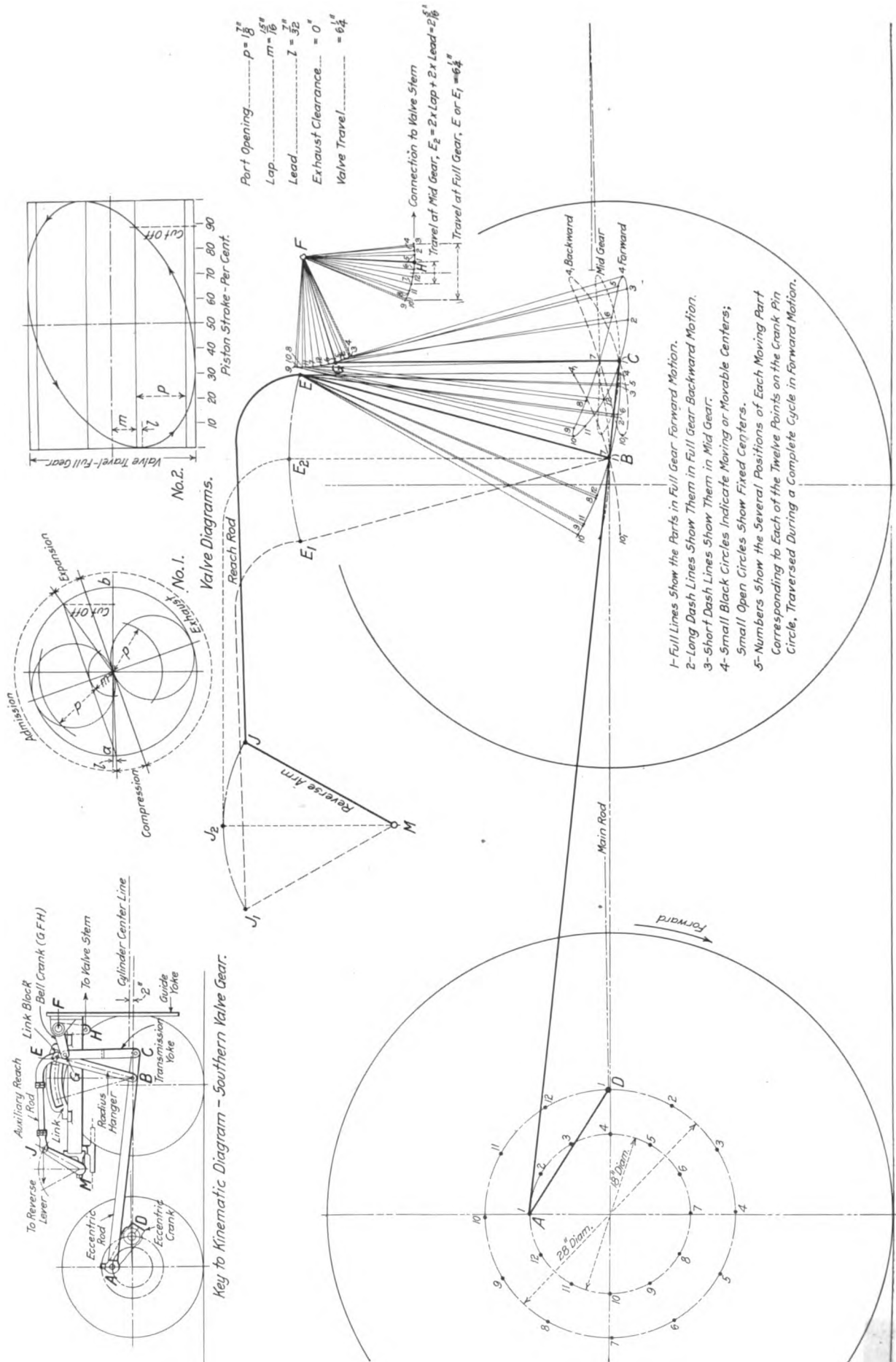

Kinematic Diagram of the Southern Locomotive Valve Gear with Inside Admission Valves

distance between the ends is a maximum. For full gear backward motion, the front end of the arc is above the back end an equal vertical distance. As the reverse lever is moved toward the center, the arc approaches a position tangent to a horizontal line, and at midstroke the front and back ends of the arc are on a horizontal line. Here the arc has no effect upon the movement of the valve, its motion being derived from the lever action of the eccentric rod, as was explained in a previous paragraph. The path of the front end of the eccentric rod (and the lower end of the transmission yoke) *C*, is, therefore, the resultant of the movement of the back end of the eccentric rod in a circle, and the fulcrum *B*, in an arc whose radius is *BE*. The path traced by the point, *C*, takes the well known elliptical form. Motion is transmitted from this point to the horizontal arm of the bell crank, *GFH*, through the transmission yoke, *CG*. The vertical arm of the bell crank is direct-connected to the valve rod.

Attention is called to the design of the bell crank. When it is in central position, the "horizontal" arm slants slightly downward and the "vertical" arm has a certain backset. This compensates in a large measure for the angularity of the eccentric rod and main rod, by causing the valve to travel equal distances backward and forward from its central position, and tends to "square" the valve events with the piston travel.

The long dash-lined arc and ellipse show the paths of the points *B* and *C*, in full gear backward motion; and the short dash-lined arc and ellipse show them in mid gear position.

VALVE DIAGRAMS

Valve diagram *No. 1* is drawn to suit the dimensions of the valve and ports. It shows the long port opening and free exhaust obtained at full gear. Diagram *No. 2* shows the valve ellipse for full gear plotted from the kinematic diagram. It should be noted:

(1) That the port is fully opened at about 15 per cent of the piston stroke, and does not start to close until about 57 per cent, the dwell depending upon the overtravel of the valve.

(2) The cut-off occurs at about 88 per cent of the stroke, while the valve is moving at a comparatively high velocity.

The illustrations show the application of the Southern valve gear to a Pacific type locomotive with inside admission valves and to a Ten-wheel locomotive with outside admission valves.

THE BEST METHODS OF DEALING WITH MEN*

BY H. E. GAMBLE

Foreman Blacksmith, Pennsylvania R. R., Altoona, Pa.

Keep your assistant in touch with all your work and correspondence, so that in your absence he will be able to answer any questions which pertain to your shop. Every man, no matter what position he occupies, has a sense of personal pride and honor. The workman of today is not a machine that can be driven. The day for that kind of supervision or generalship has passed. Workmen of today are commanding more respect and more freedom of thought than ever before. A foreman should never be domineering, manifesting a spirit and disposition that he knows it all. In doing his work, if a man offers a suggestion, listen to him. If it answers the purpose quite as well as your own, adopt it. It will make him feel good, and will draw out the best thought that is in the man, and will encourage all of the men to think. Never throw cold water on a good suggestion. If his way is not practicable, tell him kindly why it is not. You still retain his confidence and respect.

Do not get all on fire when the master mechanic or the general foreman visits your shop; do not bustle around, telling one man to do this and another to do that—it will create confusion in your shop. If the master mechanic is at all keen, he will soon detect your weakness and inability to handle men, and your

men also will be quick to see this failing. I have seen men, and so have you, go all to pieces when some one in authority came their way. Self-control is one of the very important things in handling men. We have seen men who when anything displeased them, lost their tempers and, as a consequence, lost their heads, and after they went away, have heard the remark that "he was a fool." If possible, do not do anything that will lower your standing in the estimation of the men.

I am aware of the fact that some men may take advantage of your kindness. This is the exception and not the rule. Do not ill-treat one hundred men because four or five are ungrateful and do not appreciate your interest in their behalf. If the master mechanic should find one of his foremen discourteous, or gruff to his men, is that any reason why he should issue a circular letter in which all his foremen are accused?

There are two very important factors in getting out work: First, the man's ability to do the job. Second, his willingness to do it. Encourage shop kinks and draw out the very best that is in the men. To get the best results, the foreman should be in close touch with his men. Study, if possible, the character and disposition of your men. This will help you to distribute work to the best advantage. Religion, politics, or personal friendship should have no place in the shop. All men should be treated the same. If this principle is carried out, the foreman will have the full confidence and respect of all his men, without which he cannot be successful. He should be firm, but kind and just, letting his men know what he wants and what is expected of them. Never countenance or encourage tale-bearing. A foreman's character should be such as would appeal to his men in everything that stands for good, pure and upright manhood. For instance, if the foreman patronizes the dram-shop, how can he exercise discipline over his men if they do the same? Character is a mighty thing, and stands for much in all departments of life. When men respect us for our character and not for our reputation, we have accomplished much.

If you issue orders, you should see that they are not violated, but obeyed. If at any time you have cause to reprove or call any of your men to account for neglect of duty, do it privately, never publicly or while you are in a bad humor. Never swear at your men. To abuse, punish or make unkind remarks to men in the presence of others lowers your standing in the estimation of the men, and you will not accomplish anything. It will only give men an opportunity to criticise you after you go away.

In getting out work, the co-operation of the individual workman is very essential. You should be in close touch with your men, so that they will work just as hard when you are not looking at them as when you are standing by the machine. The same friendly relations should exist between the foreman and his men as between the master mechanic and the foreman. When a man works hard and does you a good or quick piece of work, tell him you appreciate his effort.

Encourage the men and boys to use their best efforts to be useful. It is certainly a matter of gratification and pleasure to you to have the master mechanic intimate that he appreciates your efforts. Carry this same principle when dealing with your men. Method, system and organization are the shop essentials, but with all that do not forget that the individual study of your men and their co-operation is needed to make any system a success. In a shop doing miscellaneous work, the foreman will be called upon to use judgment so as not to delay or hold the work in changing men from one job to another. At one time the foreman was looked upon by the majority of men as an enemy. The men claimed that those in charge rushed work, using the argument that it was in a hurry in order to cut piece-work prices. We should be very careful not to practice deception or misrepresentation in any of our shops in this respect. Honest dealings with men on the part of those in authority will insure success. There is a better feeling existing today between the employer and the employee. This is evidenced by the pension system that is being provided by almost all corporations.

*Read before the convention of the International Railroad Master Blacksmiths' Association at Milwaukee, Wis., August, 1914.

JERSEY CENTRAL FREIGHT CAR REPAIR SHOPS

Plant Handles 4,000 Cars a Month; Includes a Sand Blast House for Steel Cars and Tenders

During the year 1912 the Central Railroad of New Jersey added to its Elizabethport shops, which then consisted of locomotive and coach repair shops, a freight car repair plant designed to take care of both wooden and steel cars. This plant was completed and placed in operation during the fall of 1912. It includes a planing mill, a building for the storage of finished freight car lumber, a car repair shop, a sand blast house, a paint shop and a small building for paint storage, the latter including a mixing room and a room for cutting and storing stencils. The plant has a capacity of about 4,000 cars a month, and at the present time the greater part of the output is wooden equipment.

This plant required the building of an extension to the power house to accommodate two 500 hp. Babcock and Wilcox water tube boilers, two direct connected 400 kw. direct current generator units and one Ingersoll-Rand, high duty air compressor with a capacity of 3,386 cu. ft. of free air per minute at 100 lb. gage pressure. The power house is connected to the planing mill and car repair shop by means of tunnels in which are lo-

patented collector and sawdust separator located on the roof of the sawdust house, a small building situated near the planing mill but not shown on the drawing of the plant layout. The sawdust is here automatically separated from the coarse shavings and deposited in a bin placed in the upper part of the building, from which it may be delivered through chutes in the side of the building for loading cars, or into bags from a chute within the building as required, the sawdust being used for various purposes along the road. The coarse shavings are delivered from the collector to the intake of a long distance fan by which they are driven through a 20 in. sheet metal conduit about 700 ft. long to another collector on the roof of an auxiliary power plant near the coach repair shop, where they are used as fuel.

The planing mill has a well equipped tool room, within which is provided room for the shop switchboard and other electrical apparatus. Aside from racks for the storage of small tools and machine tool cutters, the tool room contains complete equipment for the maintenance of cutting tools. This includes a band saw filer and setter, a band resaw sharpener, a circular

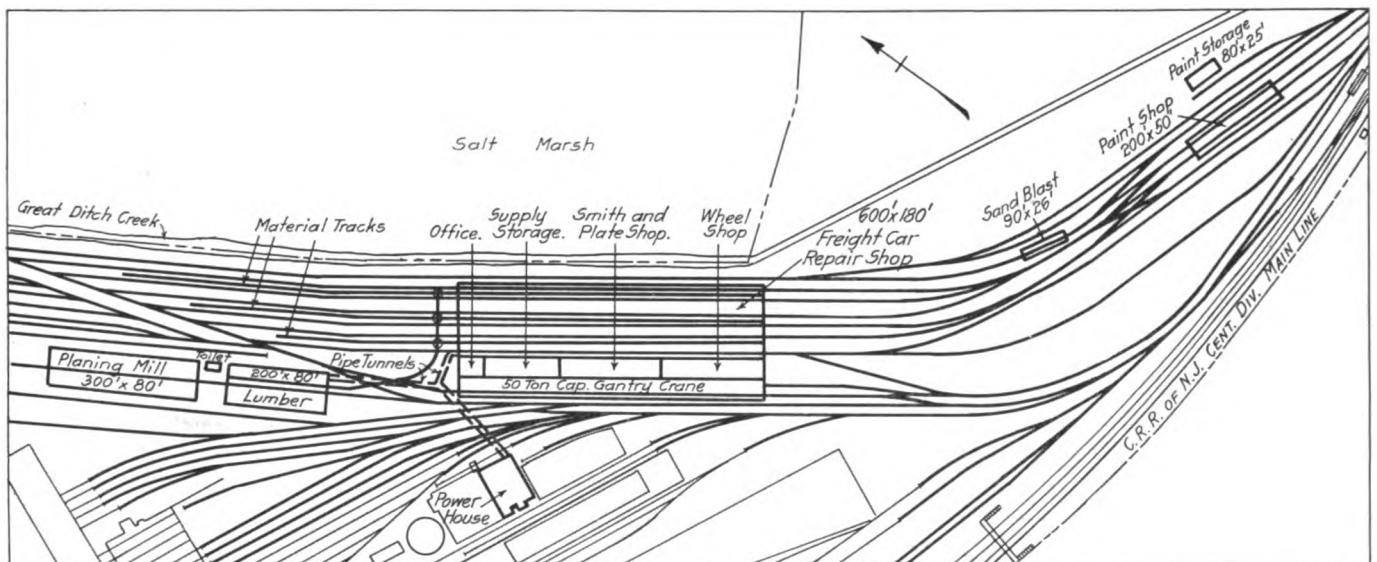

Layout of Central of New Jersey Car Repair Shops at Elizabethport, N. J.

cated the wiring for electric light and power circuits and the piping for live and exhaust steam, fuel oil and compressed air.

The buildings are so grouped that the movement of the cars is practically continuous in one direction from the time of entering the repair shop until painted and ready for service. The planing mill, which forms one end of the group, occupies a building 300 ft. long by 80 ft. wide, and is readily accessible to both the car repair shop and the outside repair tracks. All machines in the planing mill are equipped with individual motor drive, each machine being connected with a switchboard located in the tool room by wiring carried in conduits laid in the concrete floor. Sprague electric trolley hoists of one ton capacity are used to handle heavy timber through the mill.

The shop is equipped with a shaving exhaust system arranged to automatically collect shavings from most of the machines, and having intakes conveniently arranged to receive the sweepings from the others. This system was designed and installed by the Meadons Blower & Pipe Works, Brooklyn, N. Y., and is operated by two single 60 in. Sturtevant exhaust fans, each requiring about 25 hp., and driven by direct connected electric motors. The delivery pipes from these fans are carried to a

saw sharpener, a planer knife grinder, a resaw roller and stretcher, and an emery wheel, as well as facilities for the brazing of band saws.

The shed for storing finished lumber lies between the mill and the car repair shop, and is separated from the mill by about 59 ft. Running through the shed are two standard gage tracks, one of which is for shop transportation only. Through a series of turntables material may be delivered from this track to the material tracks in the repair yard and inside the car repair shop.

CAR REPAIR SHOP

The car repair shop occupies a building 600 ft. long and 80 ft. wide which is divided into four longitudinal bays. The south bay is separated by a brick wall from the remainder of the building and is occupied by the car shop office, the storeroom, the smith and plate shop and the wheel shop. Adjoining this side of the building is a storage yard served by a 25-ton Gantry crane having a span of 41 ft., one end of which is carried by a rail on the side of the building. A store department stock of heavy material for use in the car shop is carried within this area and is unloaded directly from the cars on a track passing

under the outer end of the crane. This stock includes steel underframes, cast steel body bolsters, drawbars, wheels and axles, etc. Wheels and axles are delivered by the crane to doors in the side of the wheel shop directly in front of the wheel presses and wheel lathe, and other material is delivered to doors in the

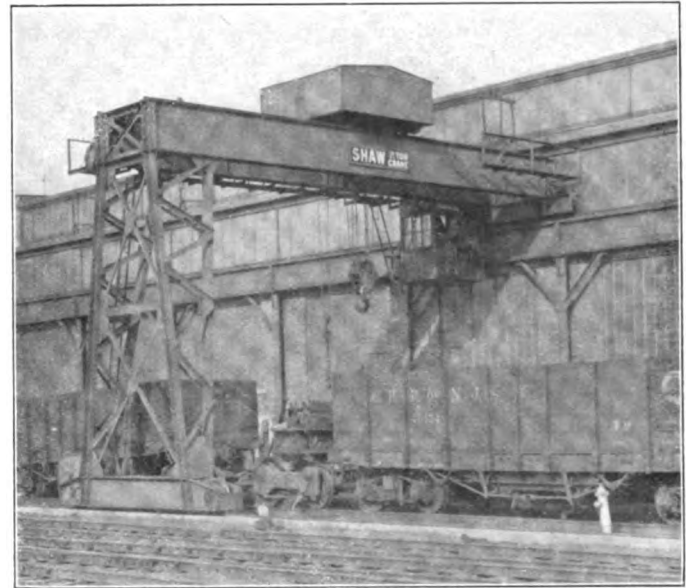

Gantry Crane over Heavy Material Storage

side of the shop from which it is carried to the erecting shop on trucks and, to a limited extent, by electric trolley hoists. In addition to its use in handling material the track under the Gantry crane is also used as a repair track, the crane service being available for this work.



Sawdust House and Separator for Planing Mill

The three bays in the erecting shop each contain two repair tracks between which is a standard gage material track. The bay adjoining the blacksmith and wheel shops is equipped for handling steel cars. It is served by two Shaw 15-ton, overhead

Cross-Section of the Car Repair Shop, Looking Toward the West End

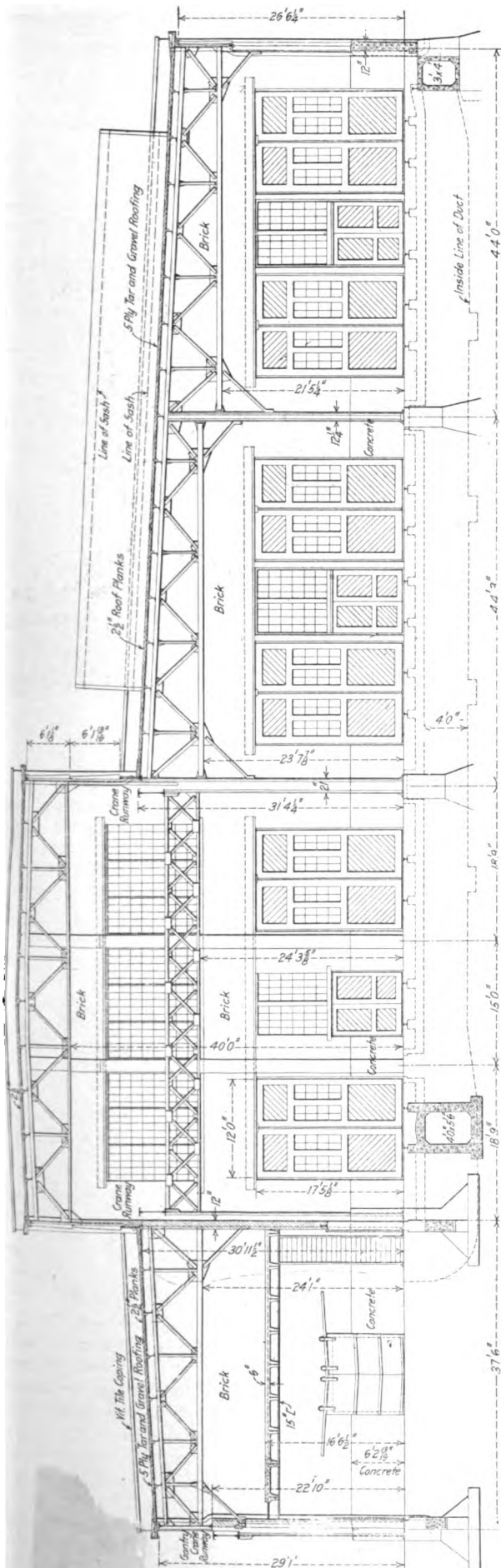

electric cranes and the blacksmith shop is readily accessible for the repairing and straightening of damaged plates or structural sections removed from the cars. All rivet heaters are portable oil furnaces, the oil being piped directly to taps conveniently located within the building. At the present time only one track is used exclusively for steel car repairs, considerable wood car work being taken care of on the other. The two east bays are used exclusively for wood car repairs. They are provided with overhead lighting by a saw-tooth roof and side light by large windows in the north side of the building.

Compressed air is carried through a 5 in. pipe in the tunnel to a point just outside of the west end wall of the car repair shop. From this point the pipe is carried up the end of the building, passing through the wall at a point about 23 ft. above the ground. The distribution system consists of one main and three auxiliary pipe lines carried overhead and extending the length of the shop. The main pipe is placed between the steel car bay and the adjoining wood car bay. The auxiliary lines are located along the north and south walls of the erecting shop and between the two wood car bays. The main pipe consists of three sections, each extending about one-third the length of the shop, the first of 5 in., the second of 4 in., and the third of 3 in. pipe. At the ends of the two larger sections are cross fittings from each of which 2 in. feed pipes lead across to the auxiliary lines north of the steel car bay. The south line is connected to the main at either end of the shop, the two lines and feed pipe thus forming a closed loop. In each of the feed pipes is placed a 30½ in. by 96 in. air reservoir from which a ½ in. drain pipe leads to the floor. Drop pipes 1 in. in diameter lead from the four longitudinal supply pipes at every second column, the columns being placed 20 ft. apart. Each drop leads to a special wye fitting, the two branches of which are connected to ¾ in. Westinghouse cutout cocks located 3 ft. 6 in. above the floor. The erecting shop is heated by hot air furnished by two



Steel Car Bay in the Car Repair Shop

fan heating sets located on mezzanine floors over the store room and wheel shop. The hot air is distributed along the south wall by a continuation of the tunnel from the power house and along the north wall by means of a longitudinal and two transverse air ducts. Outlets from the longitudinal ducts are placed at regular intervals about 20 ft. apart, the air being delivered through the floor close to the wall. The means by which the flow of air is controlled and directed at each outlet is shown in detail in one of the drawings. Air for the fans is drawn directly from the main shop space through intakes in the south wall of the erecting bay. The heating stacks are provided with

both live and exhaust steam connections, as well as a return connection to the power house.

The storeroom is about 150 ft. long and contains a store department stock of the smaller materials used in the car shop, such as malleable castings, coupler parts, rivets and bolts, grabirons, washers, nuts, etc. One end of the room is devoted to the repair and storage of air brake apparatus.

Adjoining the storeroom is the smith and plate shop which extends about one-third the length of the building and is located opposite the middle of the steel car bay. It is equipped with a Hilles & Jones No. 2 double punch and shear, one 2,000



Interior of the Sand Blast House Showing the Dry Sand Storage Bins

lb. and one 500 lb. steam hammer, a Newton cold saw and a 9 ft. by 14 ft. oil furnace for reclaiming bent plates and miscellaneous material removed from steel cars in a damaged condition. The front of the furnace is 3 ft. outside of the shop wall, and is located directly in front of a door near the middle of the shop. One end of the shop is occupied by the blacksmith fires, eight in number, which are conveniently arranged for access to the steam hammers. The 2,000 lb. hammer is placed near the middle of the shop and is served by a jib crane which also reaches four fires. Forced draft is furnished for the fires by a No. 8 Sturtevant blower driven by a 30 hp. motor and the

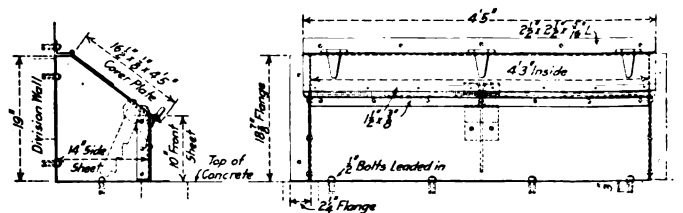

Hot Air Duct Outlet Used in the Erecting Shop

smoke is exhausted by a Sturtevant multivane exhaust fan driven by a 20 hp. motor. At the other end of the shop are grouped several machine tools, including a nut tapping machine and double head bolt cutter. This shop is designed to salvage all serviceable material removed in the car repair shop. Sprague trolley hoists of one-ton capacity are used in the blacksmith shop to a limited extent both for carrying material from the erecting shop and from the heavy material storage outside of the building. The tracks are arranged to directly serve the Newton cold saw and the double punch and shear.

The space adjoining the smith shop and extending to the end of the building is occupied by the wheel shop. The wheel presses and wheel lathe are arranged so that mounted wheels may be rolled directly to or from each machine on tracks passing through doors opening on the Gantry craneway. A standard gage mate-

rial track enters the shop at the end of the building and extends down the center, pneumatic lifts being provided at the intersections with the cross tracks above referred to. The axle lathes are ranged along the inside wall of the shop. They are served by one-ton Sprague electric trolley hoists operating on a longitudinal track, extending over all of the machines. A transverse track with a switch connection leads to each wheel press. These are not generally used, however, as the hoists find their greatest useful-

steel, and the sides are entirely of glass from a point about 5 ft. above the floor to the roof. Continuous operating sashes are provided for the entire area of the glass, with the exception of a short distance on both sides at the end of the building, where the dry sand storage bins are located. On the end of the building toward the car repair shop is built a sand drying room of brick and concrete construction, and beyond this is a frame sand storage shed.

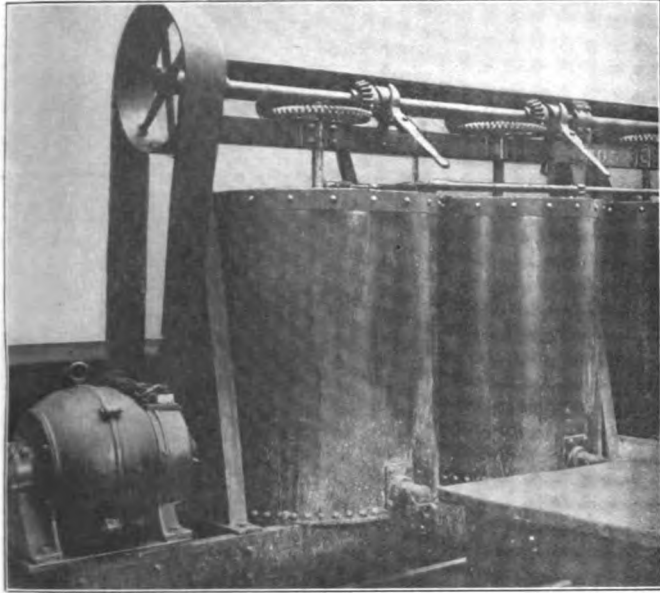

Barrel Paint Mixers in the Paint Storage House

ness in handling axles into and out of the lathes rather than in shop transportation since the lathes and wheel presses are seldom operating in synchronism.

SAND BLASTING AND PAINTING

The work of sand blasting both steel cars and locomotive tenders is carried on in a building provided exclusively for that purpose. This building is 90 ft. long and has one standard gage track extending throughout its entire length. It is 28 ft. wide inside and thus provides ample room on either side of the track. The construction is of concrete, brick and

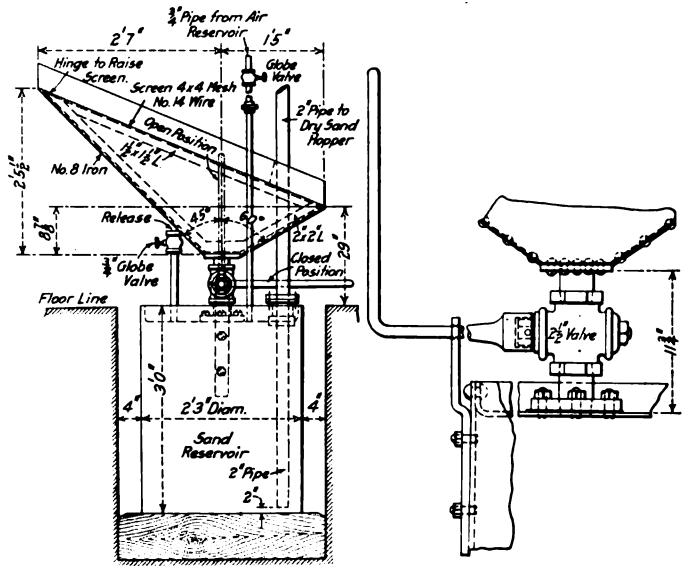

Dry Sand Elevator Used in the Sand Blast House

The sand drying stove is of very simple construction. It is made up of three ring sections and a hemispherical top, all of cast iron. The lower ring forms the ash pit and a smoke flue connection is provided in the top of the hemispherical section. A sand hopper surrounds the stove to the grate, delivering sand to the floor through gates at the bottom.

There are two dry sand storage bins in the sand blast house, one on either side of the building. One of these contains new sand only, used sand being carried in the other. Sand from the drying room is elevated to the storage bin in the sand blast house by a pneumatic ejector, the essential

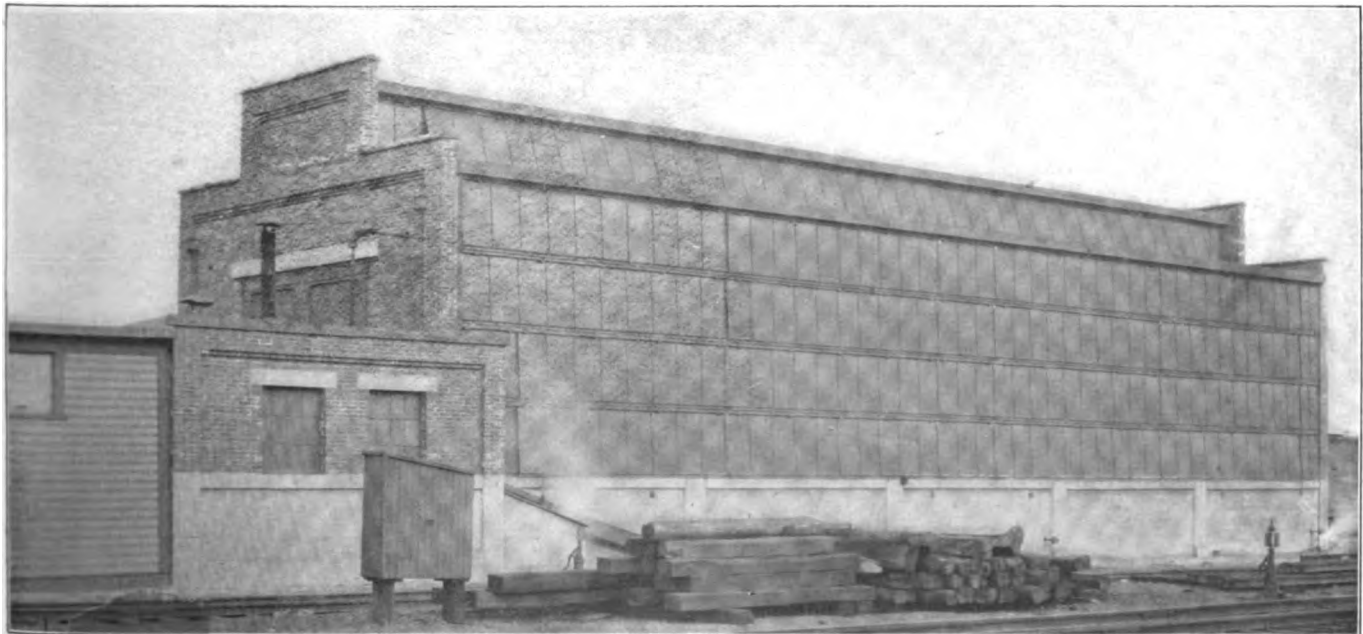

Sand Blast House; the Sides Are Enclosed with Continuous Operating Sash

details of which are shown in one of the engravings. The sand is shoveled from the floor into a screen-covered hopper, from which it runs into a steel tank below the level of the floor. When the tank is filled the plug cock in the hopper connection is closed, and the sand is elevated to the bin by means of compressed air. A similar hopper is located under the used sand bin. It has been found that the sand may be used several times before losing its cutting power, and this hopper is employed in elevating used sand from the floor to the bin above it. A supply of either quality of sand is thus always available.

The paint shop occupies a building 200 ft. long by 50 ft. wide, through which extend two tracks. This building is well lighted and ventilated by windows of the same construction as those in the sand blast house. It is provided with a loose cinder floor which is much more readily kept clean than a hard floor, where pneumatic paint sprays are used. The paint storage and mixing rooms are in a separate building, near the paint shop. The mixing room contains four motor-driven Kent barrel mixers, served by a differential trolley hoist by means of which barrels are readily handled from the floor and dumped into the mixer tanks. In addition to paint storage rooms this building also contains a stencil room, provided with facilities for cutting and storing the stencils for freight car lettering.

IMPROVED PERFORMANCE WITH OLD-TYPE COALING FACILITIES

BY J. S. WILLIAMS

General Foreman, Chesapeake & Ohio, Charlottesville, Va.

The old style coal bin as a means of coaling locomotives is still much in evidence on some railroads at points where considerable numbers of engines are handled. With such facilities the mechanical department is confronted with the problem of keeping the cost of turning engines within reasonable limits, as well as getting engines coaled in time to make the necessary running repairs before their layover time is up.

Where engines are coaled from a bin the usual practice is to dump the coal from the car to the floor of the bin, from which point it is shoveled into buggies and hoisted to the tender of the locomotive. Handling coal in this manner requires considerable labor, and where many engines are handled is very slow under the best of conditions. A plan has been put into effect on the

the width of the car, these being used to close the hoppers when the buggies are filled. The coal that runs over is shoveled up in order to keep the floor clean, so that the manipulation of the buggies will not be hampered.

By following this method the second handling of the coal has been done away with, and not only has a saving in time and cost of coaling engines been effected, but there has been noticed a marked reduction in steam failures. This is accounted for by the fact that a much more uniform grade of coal is now being delivered to the locomotives, all engines getting about the same percentage of slack and lump. When the coal was dumped on the floor a large portion of the lumps rolled to the outside of the pile. The first engines coaled after a car had been dumped got a large percentage of the lumps, while later engines got a large percentage of slack.

JAPANESE RAILWAYS DYNAMOMETER CAR

BY EDWARD C. SCHMIDT

Professor of Railway Engineering, University of Illinois, Urbana, Ill.

Some months ago the writer was commissioned by the Imperial Government Railways of Japan to design and to have built in the United States, a dynamometer car. This car, which was completed and shipped during the past summer, has recently arrived in Japan. The general dimensions and the general specifications of the car were laid down by Mr. S. Matsuno, chief of the motive power section of the Japanese government railways. In the choice of the car design and of the type of equipment, as well as in all details, the designer was left free to follow his own judgment.

The car was designed to measure and to record data needed in making tests to determine train resistance and tests of locomotive performance on steam roads. It is accordingly equipped to record drawbar pull, drawbar work, speed, time, distance traveled, position of mile-posts and stations, the direction and velocity of the wind with respect to the car, and the vacuum in the brake cylinders. In addition to these records, it is possible on occasion to record also such data of locomotive operation as the time of taking indicator cards, the position of the reverse lever and throttle, etc.

The car itself is 47 ft. 10 in. long over the buffers, 8 ft. 6 in. wide over all and 12 ft. high. The underframe and platforms are of steel and the body of wood. It is finished

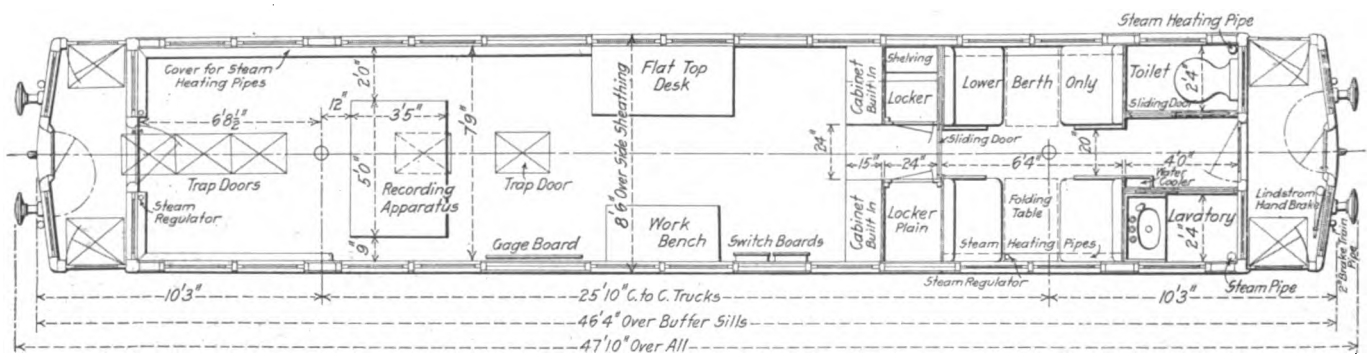

Floor Plan of the Dynamometer Car

Chesapeake & Ohio at Charlottesville, Va., whereby the handling of coal has been reduced from 8½ cents per ton to 5½ cents per ton, the force required being reduced about one-third, and the engines being coaled with greater despatch.

Instead of dumping the coal directly onto the floor of the bin two buggies are placed under the car at one time and filled by opening the hopper doors far enough to facilitate the free running of the coal. The flow of the coal is controlled by placing under the car four 2 in. by 10 in. oak planks, 36 in. longer than

within in quartered oak. The trucks are of 3 ft. 6 in. gage, of all-steel construction and suitable for high speeds. The car has the buffers, vacuum brake, and hook and link couplers, which are common in Japanese railway practice. A space of 13 ft. at the rear end of the car is occupied by a berth section, lockers and lavatories, leaving a workroom 7 ft. 9 in. wide by 27 ft. long, which contains the recording apparatus, work bench, desk and other equipment. The car is equipped with an axle generator and storage battery, which furnish

current, not only for the lights but for the motor and magnets incorporated in the recording apparatus, and for other electrical equipment.

Motion for all apparatus within the car is obtained, by means of gearing, from the axle of an auxiliary truck, located behind the forward car truck. This truck carries a pair of small wheels on a single axle whose relation to the car axis remains fixed, thereby permitting a simpler arrangement of gears than if the motion were derived from one of the axles of the regular trucks which have a considerable motion with respect to the car axis. Furthermore, since the wheels of the auxiliary truck are not subjected to brake-shoe action, their diameter changes much less rapidly than the diameter of the regular truck wheels, and consequently the speed of motion of the apparatus within the car is sub-

be changed from test to test to correspond in strength with the maximum working pressure in the oil.

The general design of the dynamometer mechanism is shown in the accompanying illustrations. This design has been somewhat complicated by the fact that the owners insisted on retaining the ordinary buffers, even though it should prove necessary to separately register on the record the amount of the buffer thrust. It has proved feasible, however, to avoid doing this. There is provided in the drawbar mechanism an equalizing lever which swivels on a pin carried in the central axis of the drawbar yoke. The buffers, instead of having their seat in the car frame, deliver their thrust against the ends of this lever. The thrusts on the buffers, therefore, merely set up in the drawbar mechanism internal stresses which are not transmitted to the dynamometer cylinder, and the buffer thrusts in no wise affect the pull record.

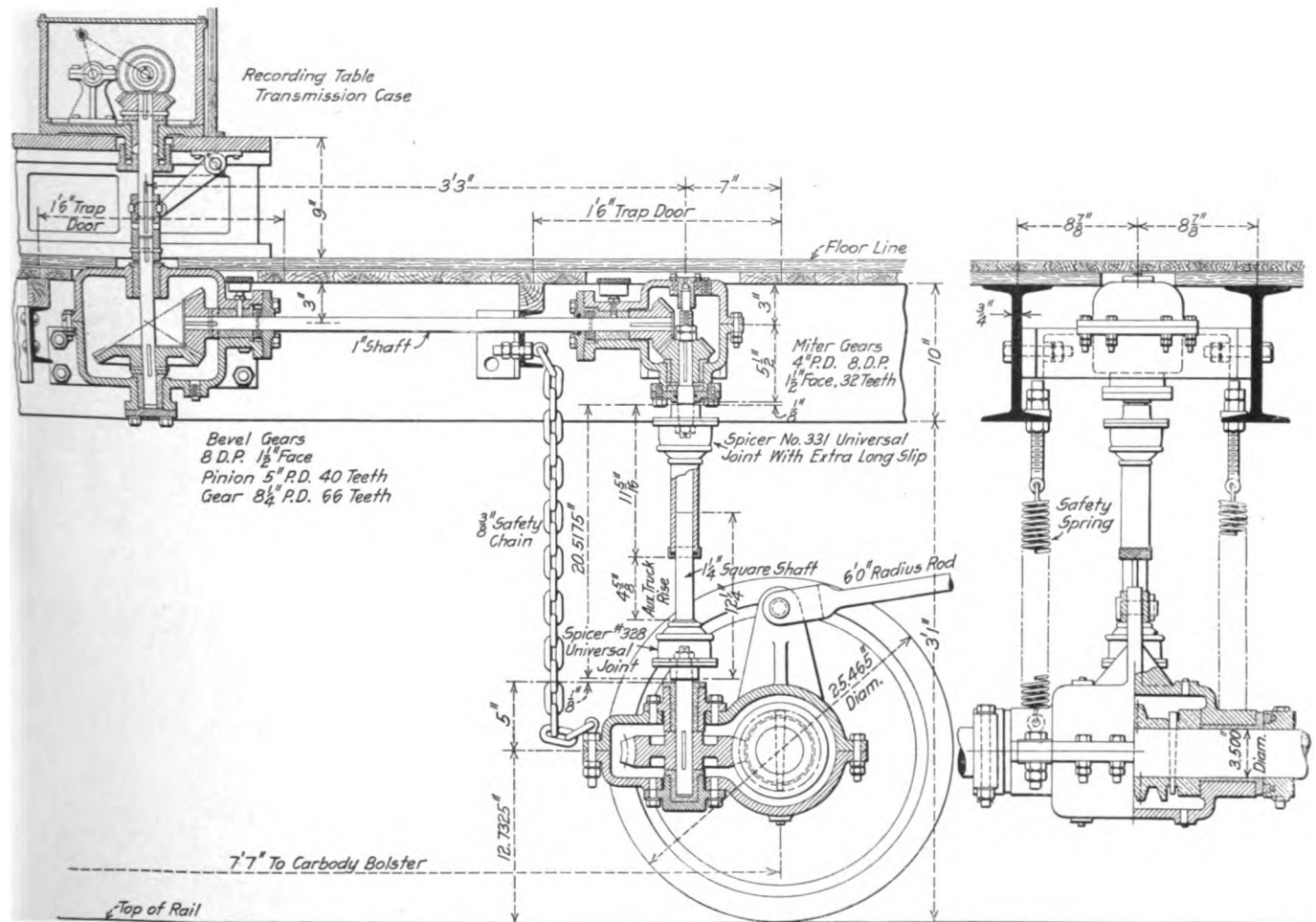

Auxiliary Truck and Gearing for Driving the Dynamometer Car Mechanism

ject to less variation and correction than if the motion had been transmitted from one of the regular truck wheels. Provision is made for raising the wheels of this truck from the rail when the apparatus within the car is not being used.

The dynamometer for measuring the drawbar pull is an oil-filled cylinder mounted on the center sills toward the front end of the car. Through a yoke the piston of this cylinder is connected to the car drawbar, and consequently the whole pull of the locomotive upon the car is received against the oil in the cylinder. The pressure built up in this oil is transmitted through a 3/4-in. pipe to a small indicator, located on the recording table within the car. The maximum pull to be registered by the car is 80,000 lb. The sectional area of the dynamometer cylinder is about 91 sq. in., and the maximum working pressure in the oil, therefore, will not exceed 880 lb. per sq. in. The springs in the indicator may

meter cylinder, and the buffer thrusts in no wise affect the pull record.

All parts of the buffer and drawbar mechanism are carried by rollers to minimize friction. For the same reason the piston of the dynamometer cylinder is not packed, the piston having a ground fit in the cylinder. As a result of this, a certain leakage of oil takes place past the piston. To compensate for this leakage, oil is pumped into the cylinder by means of a hand-operated pump. The leakage from the cylinder is received in a drip tank and is returned thence to the oil reservoir by means of compressed air, which is supplied by a small motor-driven compressor located within the car.

All records are made on a continuous strip of paper 30 in. wide, which moves over the surface of the recording table. When desired, the paper may be driven by means of a motor mounted on the table base, in which case the records

are made on a time base instead of on a distance base. When driven from the truck below the car, the paper travels either 1/16 in., 1/4 in., or 1 in. for each 100 ft. of car travel. When driven by the motor, the paper travels at either 5 in., 20 in., or 80 in. per minute. As may be seen in the top view of the recording table, all the pens for the various records are ar-

these records being controlled through the medium of electro-magnets.

The speed record is obtained by means of a Boyer speed recorder mounted on the base of the table and directly geared to one of the spindles of the main gear case. The motion of the speed recorder piston rod is transmitted to

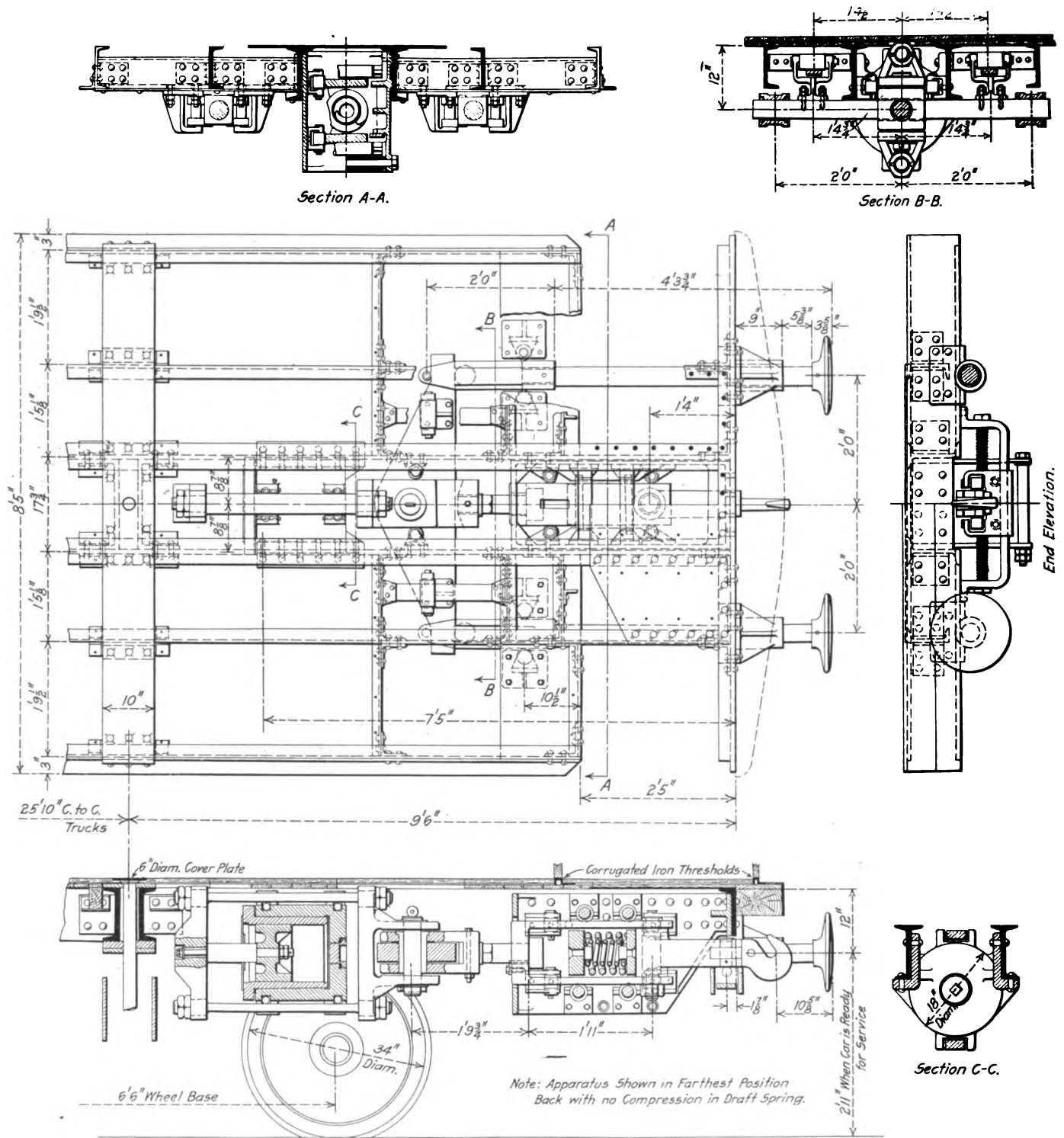

Arrangement of the Dynamometer and Allied Parts, Showing the Method of Taking Care of the Buffer Thrusts

ranged to travel in the same straight line. Datum pens arranged in front of these pens draw base lines for the records of drawbar pull, speed, wind direction and brake cylinder pressure. All other records are drawn as straight lines, with offsets occurring in the lines at certain intervals, the pens for

the upper surface of the table and transformed from a vertical to a horizontal motion by means of a slotted bell-crank which moves a small carriage on the top of the table, shown at the right in the top view of the recording table. This linkage also increases the normal maximum travel of the

Boyer gage from 3 in. to 6 in. Provision is made for driving this instrument at twice its normal speed. For low-speed tests, the speed recorder is run in high gear, and for high-speed tests in the low gear. The shift from high to low gear may be accomplished either by one of the operating levers or by means of an electrically-operated clutch which

on the chart through the medium of a pen controlled by an electro-magnet.

The pen which draws the record of pressure in the brake cylinder is carried on an extension of the piston rod of a small indicator similar in design to an ordinary steam engine indicator, the cylinder of this instrument being connected with the main cylinder of the vacuum brake. The record of distance traveled is made by a pair of contact points placed on one of the gears of the main gear train, which makes one revolution for each 1,000 ft. of car travel. These

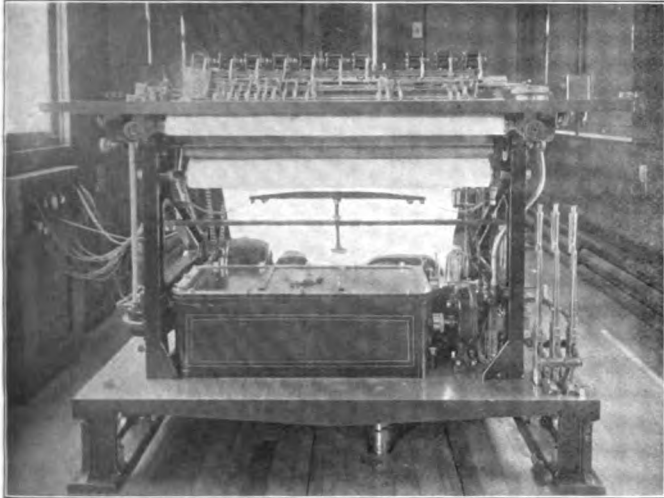

Front View of the Recording Table

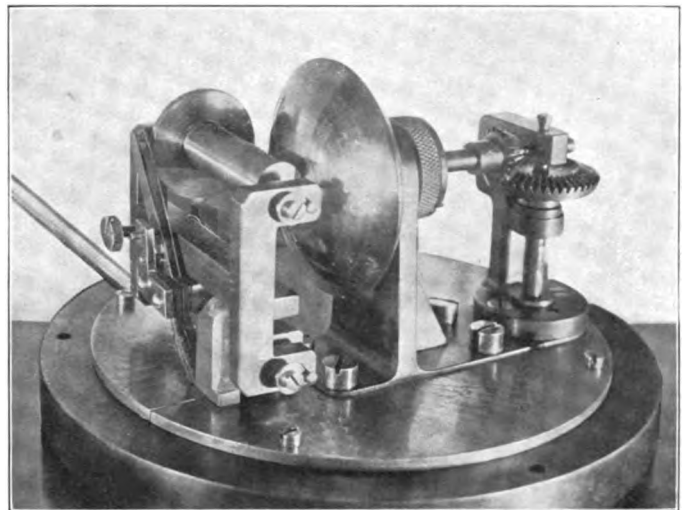

Instrument for Recording the Amount of Work Done at the Drawbar

goes into action when the speed curve pen reaches the limit of its travel. A speedometer, such as is commonly used on automobiles, is used for determining the momentary speed. These instruments have a range up to 85 m. p. h., and it is expected that the car will occasionally be operated at that speed. Wind direction with respect to the car axis is also recorded on the chart. The spindle of a wind vane mounted on the roof of the car projects downward to the recording table where, through a crank and a yoke, it is connected to

contact points control an electric circuit through one of the magnets, which in turn controls the distance pen.

A work recorder or planimeter, whose purpose is to automatically record the area included between the curve of the

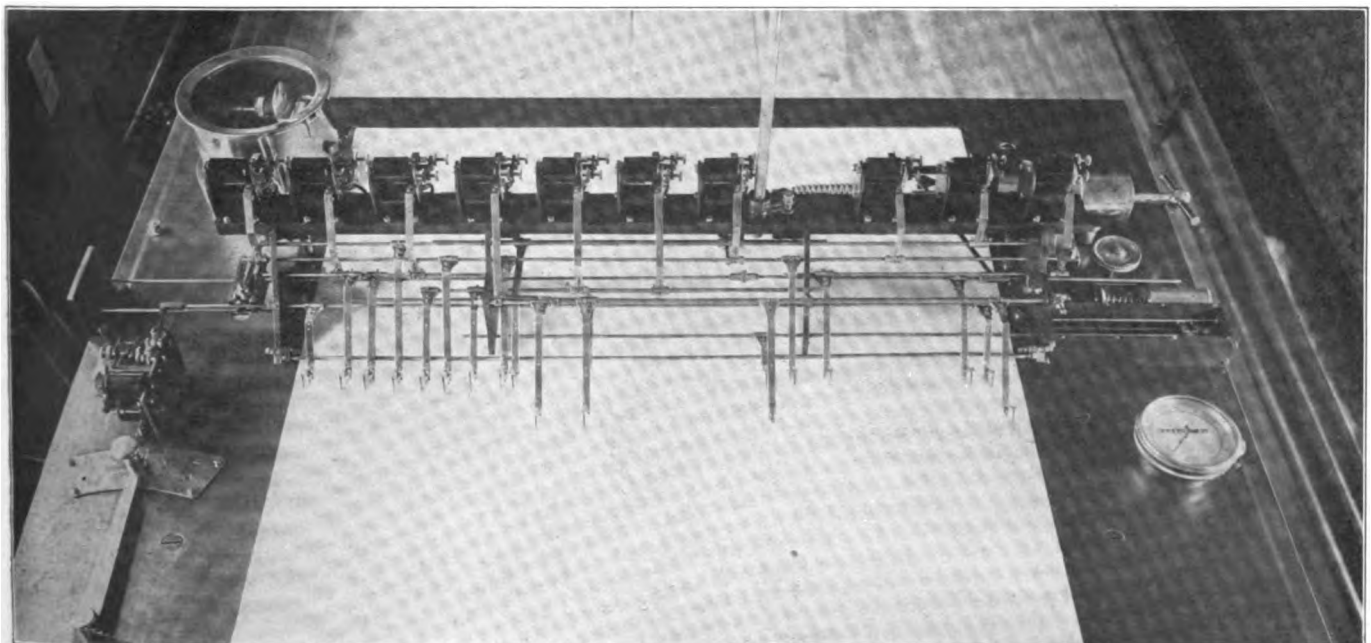

Top of the Recording Table in the Japanese Government Railways Dynamometer Car

the wind direction pen. This pen draws a curve whose ordinate is the sine of the angle made by the wind vane with the longitudinal axis of the car. The wind velocity record is obtained by means of an anemometer of the pattern used by the United States Weather Bureau, and makes its record

drawbar pull and its datum line, is used on this car, the design being shown in one of the photographs. It consists essentially of an accurately ground steel cylinder, which is in contact with and is rolled by a ground spherical surface. The spindle which carries the segment of the sphere, shown

in the photograph, bears a fixed relation to the table. By means of gearing this spherical segment is driven at a rate proportional to the travel of the paper. The cylinder, on the other hand, is carried in a frame so pivoted that it may be turned about a vertical axis. To this frame, near the bottom, there is attached an arm, a portion of which appears in the photograph. This arm terminates in a wheel which plays in a slotted carriage carried on the end of the rod attached to the drawbar pull pen. The carriage may be seen at the left side of the recording table. By means of these connections, any movement of the drawbar pull pen results in a corresponding change in the angle of the frame which carries the rolling cylinder. The cylinder is kept continually in contact with the sphere by means of a spring attached to the cylinder frame. The roll of the cylinder, which is directly proportional to the speed of revolution of the sphere and to the tangent of the angle which the cylinder axis makes with the sphere axis, is consequently also proportional to the paper travel and the pull curve ordinate. In other words, the roll of the cylinder is proportional to the area included under the curve of drawbar pull. The proportions of the instrument are such that for each 3 sq. in. of area the cylinder will make one complete revolution, and for each revolution an offset is made by the work recording pen.

The time record is made at both edges of the chart by means of two pens mounted on one rod, which is operated by the cam and magnet mechanism shown at the left of the recording table. A clock making electrical contacts every five seconds controls these magnets, which in turn operate the pen rod through the medium of a pair of cams. The design is such that the record distinguishes not only five-second intervals, but one-minute intervals as well. Such other rec-

to the armatures of electro-magnets mounted on a bridge across the table top. These magnets are controlled by means of push buttons, the wiring for which is permanently installed in the car.

As additional evidence of Japanese progressiveness, it may

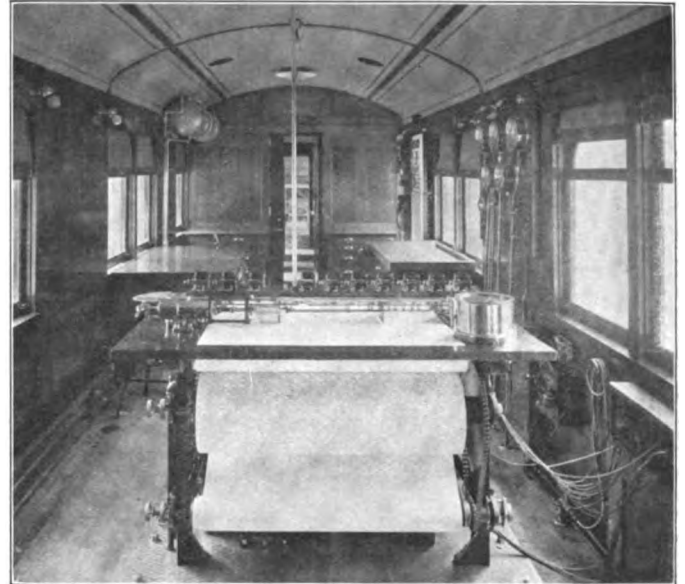

Interior of the Dynamometer Car

be of interest to add that the Japanese government railways have also recently installed, near Tokio, a thoroughly-

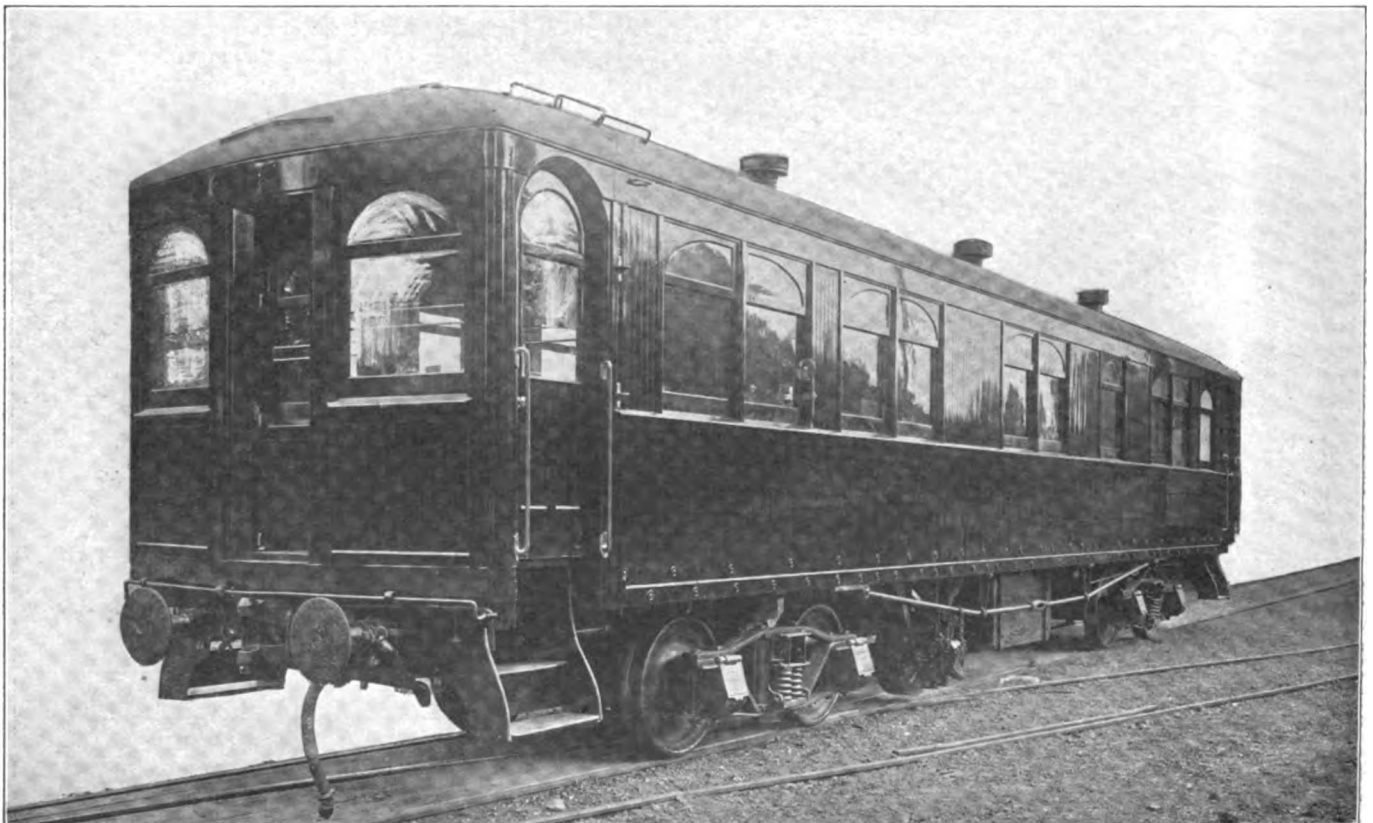

Dynamometer Car for the Japanese Government Railways; the Trucks Shown Are Temporary

ords as the position of mile posts, position at which indicator cards are taken, reverse lever position, throttle position, locomotive boiler pressure, etc., may be made on the chart by means of a number of extra pens whose arms are connected

equipped laboratory for testing locomotives. With this plant and the dynamometer car, the Japanese railways have for experimental study of the problems of locomotive and train operation, facilities equaled on only one American railway

CAR DEPARTMENT

CAR CONTROL*

BY JAMES FITZMORRIS

Master Mechanic, Chicago Junction Railway, Chicago, Ill.

It has been the history of the world that it is easy to start something, but hard to control what has been started, and lack of proper control in the movement of trains and cars has so far-reaching and so wide an effect upon all branches of railroading that car control would seem to be an all-important consideration. The business of a railroad, of course, is primarily that of moving freight and passengers; this often seems to be forgotten in the unending multitude of things that are necessary for the effective handling of traffic. There are millions of dollars invested in right-of-way, terminals, freight yards, rolling stock and motive power, but they are all subordinate to the one principal business of transportation in its primary meaning.

When the control of the car is mentioned, the air brake, because of the intricacy of its design and construction, is naturally thought of first, and the brakebeam, apparently a much more simple appliance, is lost sight of. An air brake is of very little value without a brakebeam of the right design, construction and material. I want to call attention to the defects in brakebeams, for the reason that not only is a brakebeam's work important, but that the importance of its work is so often lost sight of. After a brakebeam has been placed on a car, the car in a train, and the train is in motion, our control of the brakebeam, and so of the car, is limited by the construction of the brakebeam. The always and ever-present necessity of perfect control of the car, which is a unit in the moving train, makes it imperative that a brakebeam be right when it is applied first to the new car, and to know that it is right means that we have got to know that the materials are right, that the design is the result of years of experience, and also that the construction has been under the direction of experts.

A defect in a brakebeam is a most important defect, for the reason that it is liable to make defective all parts of the car. A moving car that cannot be controlled because of a defect in the brakebeam may, and often does, have most disastrous results. The modern passenger train or freight train could be likened to the long end of a lever of which the brakebeam is the short end. The brakebeam is one of the few items in railroad service which can correctly be termed emergency equipment. It is something which is called upon to work at all times, and this work is not always the same. Given a fairly good track, most car equipment is called upon to do the same kind of work each day, or each trip, but not so the brakebeam. When an emergency arises, the strain and the work put upon it is multiplied many times. If a car roof or an underframe, or a draft gear, receives severe usage occasionally in the operation of a train, how much more so and more constantly does a brakebeam receive severe usage. Dangling, as it does, from underneath the car, it is suddenly thrust not against some stationary structure, but upon moving wheels with tremendous force behind it; in an emergency, this force is at the maximum, and the wheels are revolving at their fastest speed. It is hard to imagine any service more trying than that which is given to the brakebeam; yet it is required to do its work with every disadvantage, and, at the same time, even its partial failure to do the work required of it may mean destruction of property and loss of life.

Undoubtedly there is nothing that works at any greater disadvantage upon a car than a brakebeam; and the very fact of its working at a disadvantage proves that it is working at a tremendously high maintenance cost. The Railway Age Gazette, in referring to box cars, seems to imply that the defects sought are those in the underframe and above. Draft gear, box car roofs and ends, and underframes seem to be occupying the center of the stage. Their importance is not to be questioned, but the importance of the brake beam, the vital factor in the control of trains, cannot be overlooked in an industry where transportation is the chief business. I do not think it will be questioned by prominent railroad men that the most expensive item of car repairs, year in year out, not excluding couplers of draft rigging, is the brake—that is the rigging and the brakebeams. Much of the high cost of maintenance is to be explained both by the use of inadequate brakebeams and the multiplicity of designs.

The Railway Age Gazette has asked for suggestions as to how the defects may be eliminated. Suggestions for betterment would probably be of more value than criticism, and if we are to obtain betterment, so far as the brakebeam is concerned, we should use brakebeams of established and successful design and of capacity sufficient for, if not in excess of, the service in which they are put. The railroads should, through the medium of the Master Car Builders' Association, change or make standards with caution, and then insist upon their being respected after they are established. It may be that M. C. B. standards cannot very successfully be made other than suggestive as they are now, but something could be done to make them other than "paper" standards.

When the railroads went into the use of the solid beams, differing essentially only in names and location of rivet holes, and being entirely alike in inefficiency, they created a situation that will not be corrected until these beams are eliminated, and the roads are paying for this every day. The use of so many inadequate brakebeams; the use of beams having so many different interchange dimensions; the use of so many beams that cannot be successfully kept in service or repaired at any reasonable cost—these have developed a situation that delays cars every day and adds heavily to the cost of railroading.

The suggestion to make an M. C. B. standard brakebeam is an attempt to get away at one long jump from the confusion and chaos existing. This cannot be done for manifest reasons, but the railroads *can* remedy a very serious difficulty in the freight car situation today by never buying brakebeams unless they fall within the present established M. C. B. requirements. The present requirements classify the beams in relation to service, and establish their capacities and tests in interchange features and over-all dimensions. If the railroads would start today to buy only such beams as fall within these limits, the situation would gradually and substantially improve, and a big source of expense and delay would be corrected by evolution, without serious disturbance. Along this line it seems to me that if the Master Car Builders' Association had some rule that any standard should remain such for a term of years and not be subject to constant change, the freight car situation might be benefited.

Too often the brakebeam is considered of minor consequence, and its important function, and particularly how much there really is to the subject, is not understood. The most general error is to believe inefficient rigging is efficient simply because failure and accident do not occur in ordinary work or service stops. Trains are being handled daily

*Entered in the car department competition which closed October 15, 1914.

where such equipment is used and the ordinary stops made; therefore, the equipment is regarded as sufficient and by many stamped as efficient. In compliance with the law, public buildings are equipped with fire escapes, yet a small percentage of public buildings burn. The law requires that boats be equipped with all sorts of life saving apparatus, yet until the emergency arises, it rests idle and is of no service. Railway cars are equipped with the quick action brake primarily to take care of emergencies rather than to take care of the ordinary stops in the handling of trains. Today the increased speed and momentum of the heavier trains has given the quick action brake everyday usefulness which was not originally contemplated. If, therefore, the element of emergency is likely to arise and the quick action brake liable to be required, why impair or practically nullify its efficiency by the employment of inadequate co-operative elements? It would seem that the first cost of a brakebeam should never be considered, in view of the fact that it is emergency equipment, and that its value lies chiefly in the protection which it affords. When we have advanced in the art of railroading to that point where we buy one brake beam, not because it is ten cents cheaper than another, but because, whatever the first cost, this cost will be taken into consideration only in its relation to the final cost of the beam and the maintenance cost of the box car upon which it is used, we shall have accomplished a great deal.

CAR DEPARTMENT CORRESPONDENCE AND REPORTS*

BY CHARLES CLAUDY

Chief Clerk to General Car Foreman, Belt Railway of Chicago

It is generally believed that a considerable volume of the work performed in handling the correspondence and reports pertaining to the car department could be eliminated if they were given more thorough attention at the start. The manner in which these matters are handled by the car department will have a good or bad effect on various other departments of the railroad, according to the degree of efficiency in handling this work. The car department is called on to furnish information affecting such subjects as loss and damage claims, personal injuries, train accidents and responsibility for damage to equipment, in order that the responsibility may be placed where it belongs. If such information is not furnished fairly and accurately, it will cause unnecessary correspondence, impairing the efficiency of the department, and often justice will not be obtained. No effort should be made to evade responsibility by referring questions to another department or to another railroad which could be correctly answered by those handling the work.

If the complete facts are not shown in the original reports and records, trouble will surely be experienced when these are taken up for consideration. The information should be recorded in such detail as may be essential for a clear understanding of the subject at any time. Brevity is efficiency when it is not lacking in the essentials, but the necessary details should not be sacrificed for brevity. Too many employees make records of important items with only sufficient details to reinforce their own memory, forgetting that the records they make today are often to be used by someone else tomorrow. This is also another source of considerable unnecessary correspondence in the car department.

The lack of the spirit of broadness and fairness in handling reports with foreign roads is another source of unnecessary correspondence. It is perfectly proper to defend a principle that may be involved in solving large questions, but the defense of wrong principles by technical arguments, with the

hope of placing the real responsibility where it does not belong, is a waste of time and energy to any department.

Perhaps the greatest individual source of what may be termed unnecessary correspondence is the result of reporting wrong car numbers and initials. While some of these errors originate in the office, they are largely due to the car inspector or the repair track foreman. A wrong car number quoted in a bill for foreign car repairs usually means a letter of exception from the mechanical department of the foreign road to its auditing department, which, in turn, communicates with the auditing department of the road making the bill. It is then passed to the mechanical department of that road and must be investigated by the car accountant and the mechanical representative originating the information. When the error is corrected, the bill must then retrace its path to the mechanical department of the foreign road. The wrong initial carries with it even greater detail of investigation than the wrong car number, and practically the same detail is necessary in handling claims for accidents, etc., when wrong numbers and initials are reported.

The car inspectors and repair men should not be too severely criticised, as often they perform their work under very adverse circumstances. Some roads resort to discipline in an effort to overcome these errors, but it is not believed that such methods will produce the best results, as the errors are not a willful neglect of duty. If a suitable degree of efficiency cannot be obtained from the men in the field, a more fitting place in the organization should be found for them.

Another means of reducing correspondence and adding to the efficiency of the car department is promptness in handling reports and correspondence. All well regulated car departments have certain reports which are required, and if these are furnished promptly and while the subject is fresh, it will insure a clearer statement of facts, as well as avoid the too frequent necessity of being called upon to furnish them. The same is true in handling correspondence. If replies are made as promptly as possible the information furnished can be presented in better form, in less time and avoid the necessity of "urgers" being sent out which may require passing through a number of offices, adding work to each one, as well as increasing the volume of correspondence to be examined.

A defective filing system adds its share to confusion and unnecessary labor. It is often found that the information sought is already a matter of record and in the possession of the road making the inquiry, but through ineffective filing methods the connection is not made, and additional correspondence is imposed on the offices of both roads interested.

A brief and concise statement of facts, either in reports or in correspondence, is far more forceful than repetition and unnecessary details. It consumes less of the time of the person imparting the information, as well as of the recipient. In order to do this, sufficient thought should be given the subject under consideration to get a clear conception of it in the mind, after which both brevity and detail can be rounded into a harmonious combination. Failure, in answering correspondence, to make proper reference to files, often results in confusion and delay which could be avoided if this feature was given due attention.

The reduction in unnecessary correspondence and the standard of efficiency is best accomplished through an efficient organization, from the head of the department to the lowest in the ranks. Often men are employed to perform certain duties, and perfection is expected when they are wholly unqualified through lack of training to perform such service. The entire organization should be continually studied, with a view to detecting certain qualifications which could be readily developed to aid in performing effective service.

*From a paper presented at the January meeting of the Car Foremen's Association of Chicago.

UNION PACIFIC STEEL FREIGHT CARS

All-Steel Equipment of 100,000 Lb. Capacity for Automobile Traffic; Box Car Has Steel Underframe

There were placed in service a short time ago by the Union Pacific 4,000 steel underframe box cars, 2,000 of which were built by the American Car & Foundry Company, and 2,000 by the Western Steel Car & Foundry Company, and 600 all-steel

The underframe is of the Bettendorf type, the center sill consisting of a 20 in., 112 lb. I-section girder, while a cast steel body bolster is used. The end sills are 8 in., 13.75 lb. channels and 6 in., 8 lb. channels are used as diagonal braces between the end

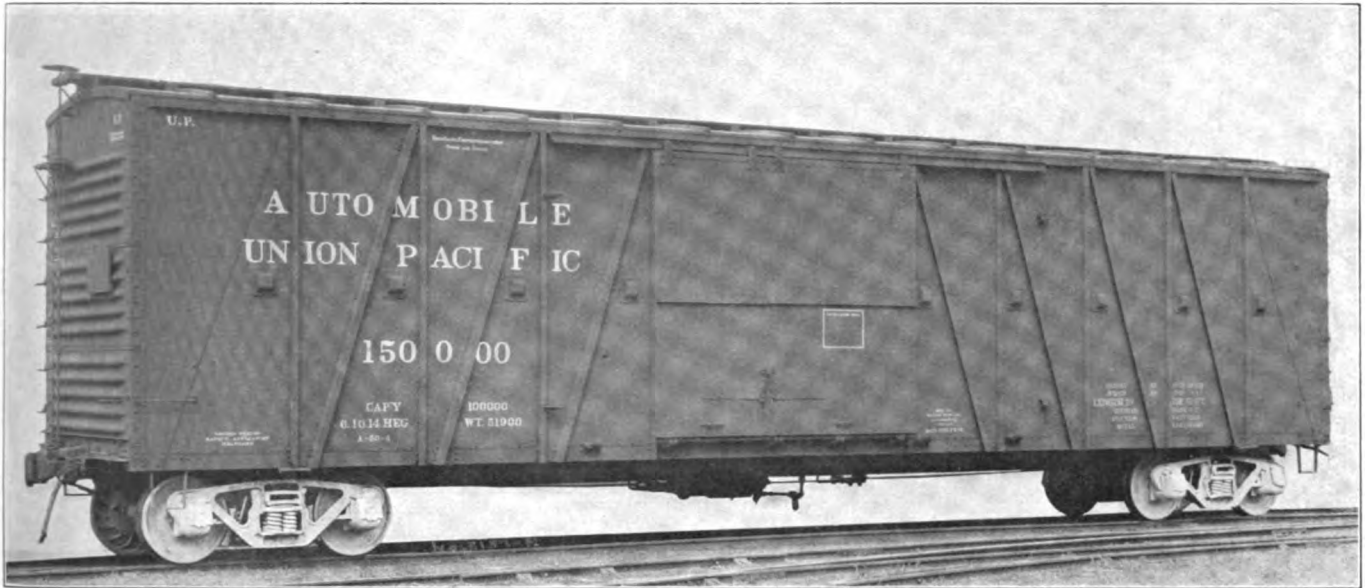

Union Pacific Steel Car for Automobile Traffic

automobile cars built by the Western Steel Car & Foundry Company.

AUTOMOBILE CARS

The automobile cars are of 100,000 lb. capacity and weigh 51,900 lb. They are 50 ft. 6 $\frac{3}{8}$ in. long over end sills and are 50 ft.

sills at the center sill and the body bolster near the side sill. The side sills are 9 in., 13.25 lb. channels and the crossies which extend between the center sill and the side sill are 8 in., 11.25 lb. channels. A 3 $\frac{1}{2}$ in. by 2 $\frac{1}{2}$ in. by $\frac{1}{4}$ in. angle extends in the form of a bow between points on the center sill just back of the



Steel Underframe Box Car for the Union Pacific

long inside. The height from the top of the floor to the bottom of the carlines is 10 ft. 1 $\frac{1}{8}$ in., and the cubical capacity is 4,630 cu. ft.

draft arms, the top of this arch being at the side sill on either side of the car. There are 4 in. by 4 in. wooden stringers used for supporting the floor and these are carried on the 8 in. chan-

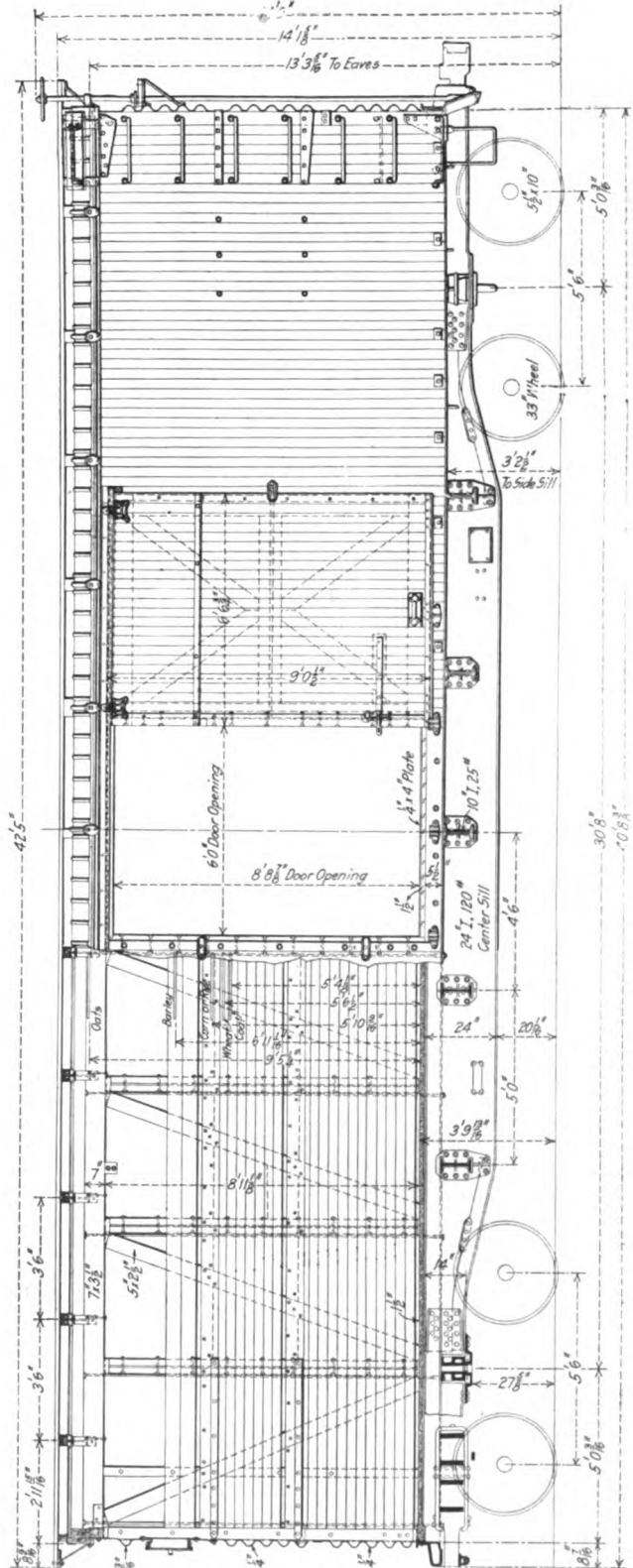
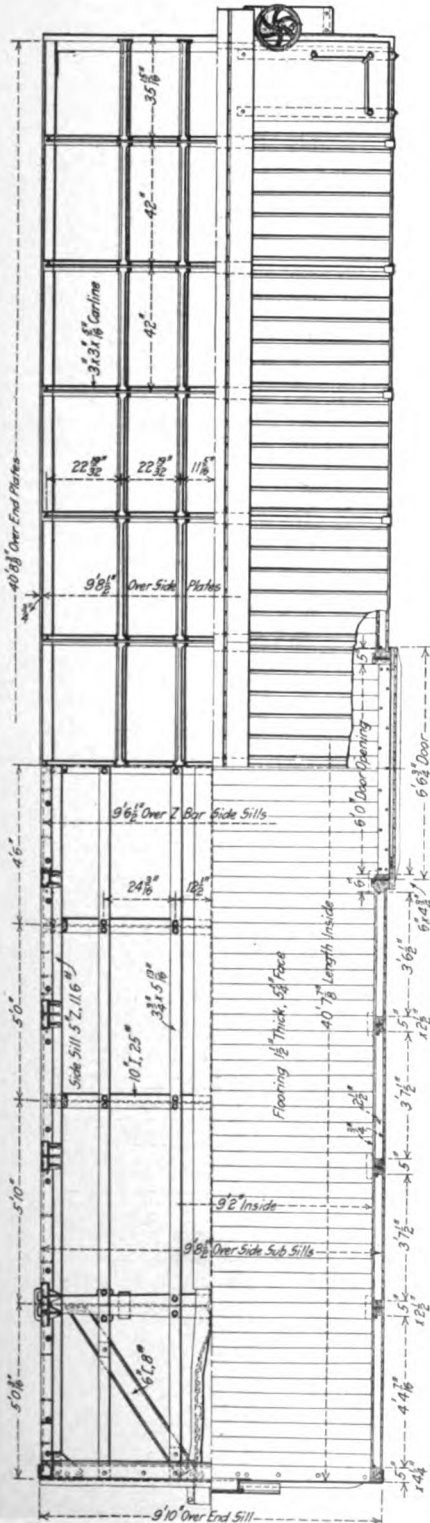
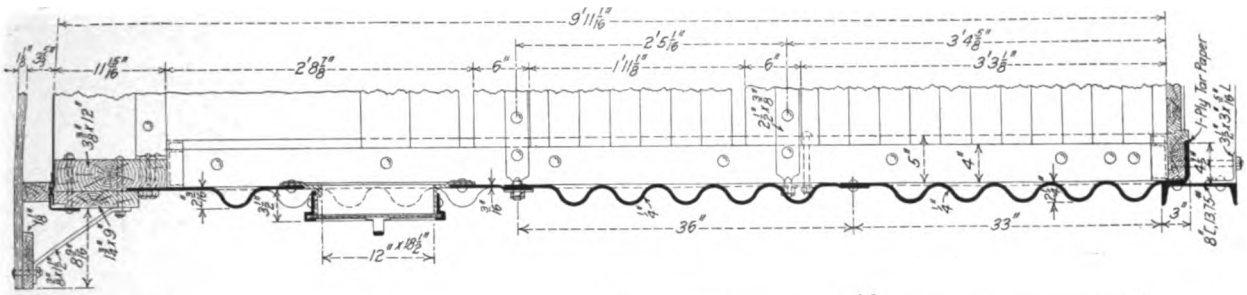

Arrangement of the Framing and Ends of the Union Pacific Box Car

nel crossies. The trucks are spaced 40 ft. 4 in. between centers and have cast steel side frames of the Vulcan type. One end of the car is fitted with steel doors swinging to either side, while double side doors of wooden construction are used. These side doors give an extreme door opening of 9 ft. 9 3/4 in., the width between the door posts being 10 ft. 3 1/2 in.

The steel body framing is made up of 3 in., 6.7 lb. Z-bar side posts and 3 in., 11.5 lb. Z-bar braces, the framing being outside the 1/8 in. steel plate sheathing. The side plates are 4 in., 8.2 lb. Z-bars and the end plates are 5 in. by 3 in. by 5/16 in. angles. The sides of the car are fitted with stringer pockets, as shown in one of the illustrations. These pockets are used to carry the ends of transverse stringers for supporting an upper deck in the car when this is required, and it will also be readily seen that they can be of material assistance in securing miscellaneous lading in place. The Murphy corrugated steel end is used, as well as the Murphy radial type of roof, the strength of the end construction being made to meet the Master Car Builders' Association recommendations. This end is made in three sections, the two lower being of 1/4 in. plate, while 3/16 in. plate is used in the upper section. The carlines are 3 in. by 3 in. by 5/16 in. tees, while there are two 3/16 in. U-section pressed steel purlines on either side of the car, spaced 27 7/16 in. between centers, the inner one being 10 3/4 in. from the center line of the car.

The special equipment includes New York air brakes, Western angle cock holders, Acme automatic brake adjusters, Scullin-Gallagher body bolsters, Creco brake beams, Climax couplers, Carmer coupler relief rigging, Camel door fasteners, Miner draft rigging, National malleable journal boxes, Buckeye cast steel truck bolsters, Miner gravity truck side bearings and Barber truck roller device.

BOX CARS

The box cars are of 100,000 lb. capacity and are also equipped with the Bettendorf steel underframe. Cars of this type having a steel underframe, steel end construction and a steel roof

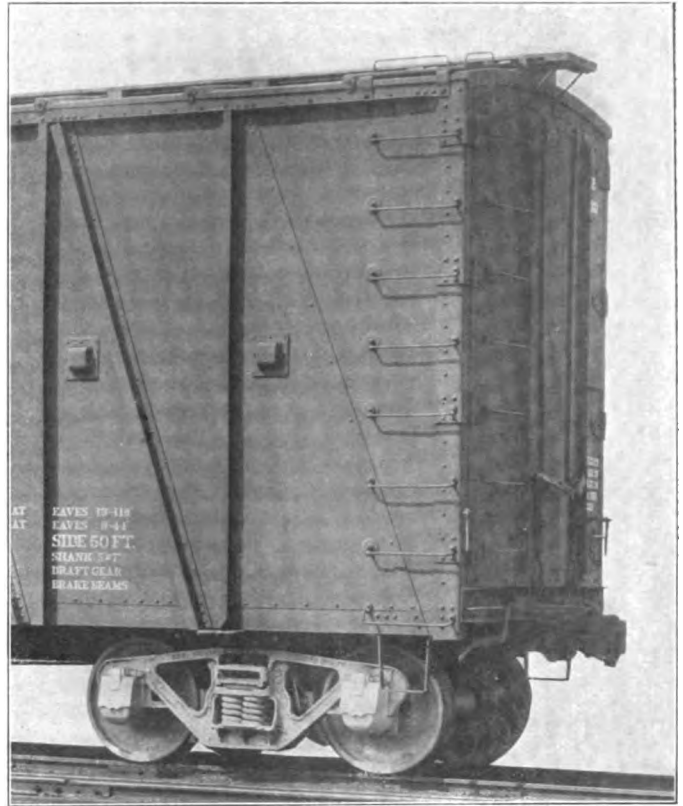

End of the Automobile Car Showing the Steel Doors

have met with distinct favor in some quarters. In point of strength it would seem that they should give almost as good results as the steel frame inside sheathed car while retaining

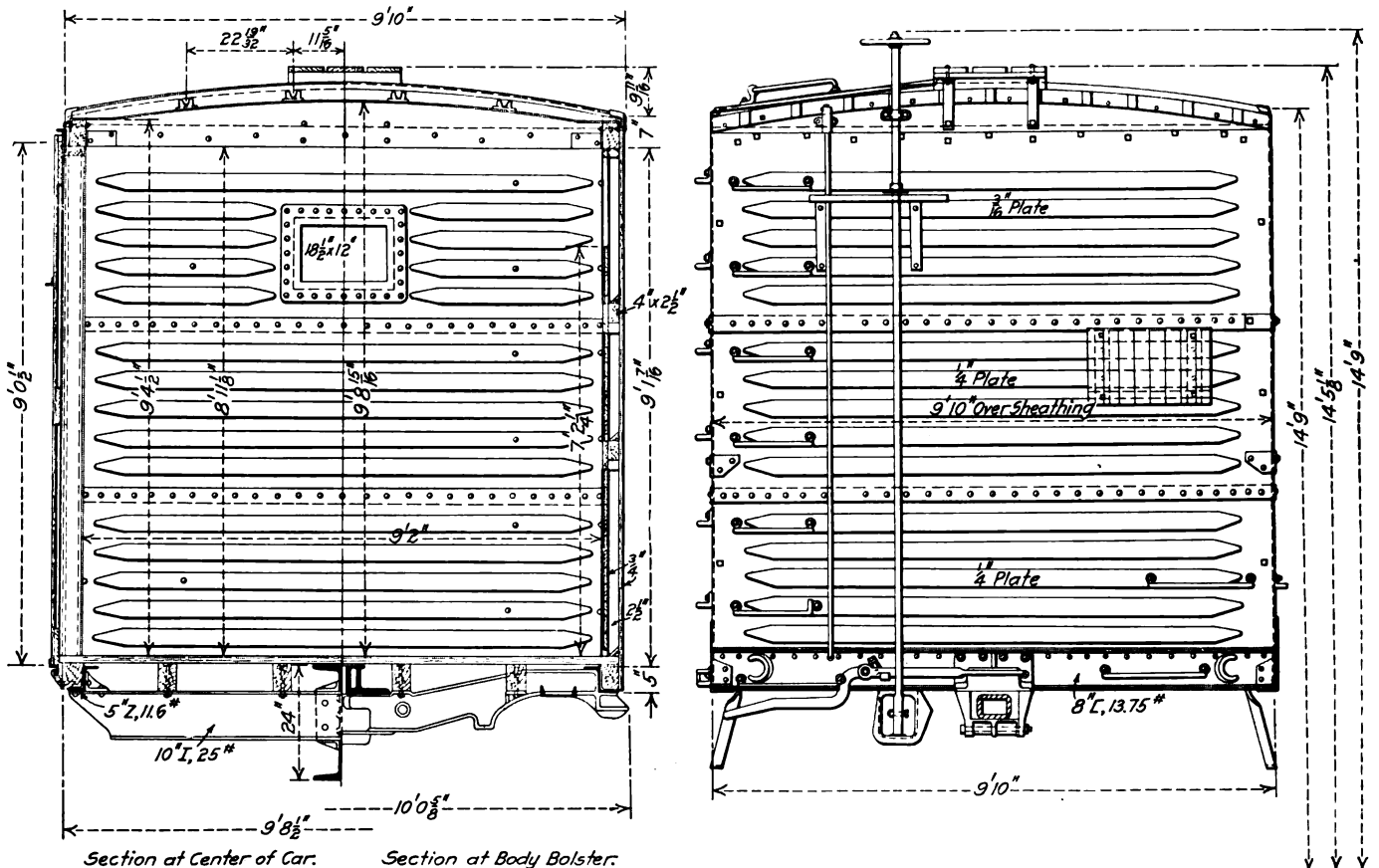

Section at Center of Car. Section at Body Bolster.

End Elevation and Cross Sections of Union Pacific Steel Underframe Box Car

the advantages of the vertical sheathing. These cars are 41 ft. long over ends and 40 ft. 8 in. long inside, the cubic capacity being 3,500 cu. ft., and the height from the top of the floor to the bottom of the carlines 9 ft. 4 1/2 in.; the weight of the car is 42,900 lb.

The center sill consists of a 24 in., 120 lb. I-section girder,

end sills at the center and the body bolsters at the side sill; the crossies are 10 in., 25 lb. I-beams. The superstructure of the car is of wood, but the ends are of the Murphy corrugated steel type, there being an 18 1/2 in. by 12 in. door opening in one end. The roof is of the Murphy radial steel type with pressed steel U-section purlines and 3 in. by 3 in. by 5/16 in., T-section car-

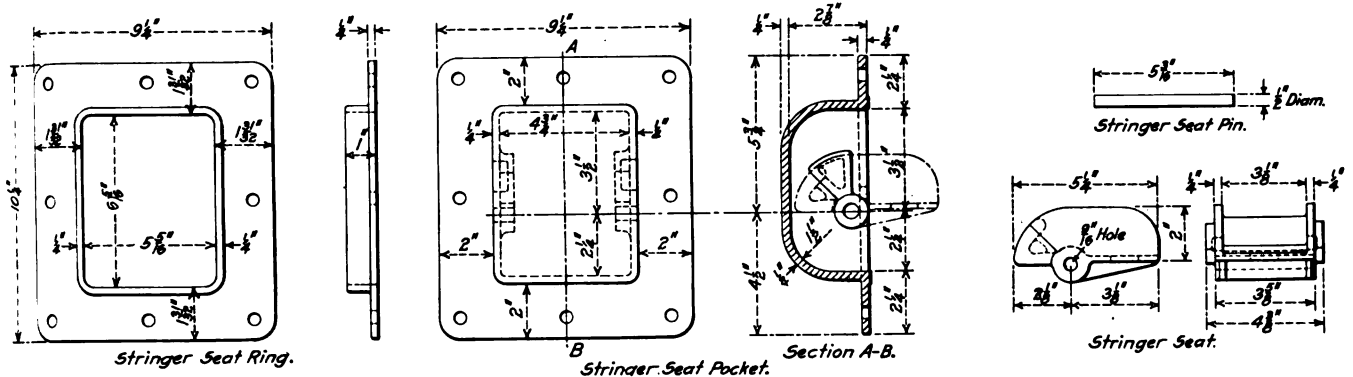

Upper Deck Stringer Pocket Used on the Automobile Car

while the body bolsters are of cast steel. It will be noticed that this center sill is heavier in the box car than in the automobile car, the reason for this being that the center sill in the box car was designed to carry the greater proportion of the lading, while in the automobile car it was the intention of the

lines, each 42 in. between centers. There are two purlines on either side of the car, spaced 22 19/32 in. between centers, the inner one being 11 5/16 in. from the center of the car.

The special equipment on the box cars includes Climax couplers, Barber truck roller device, New York air brakes, Creco

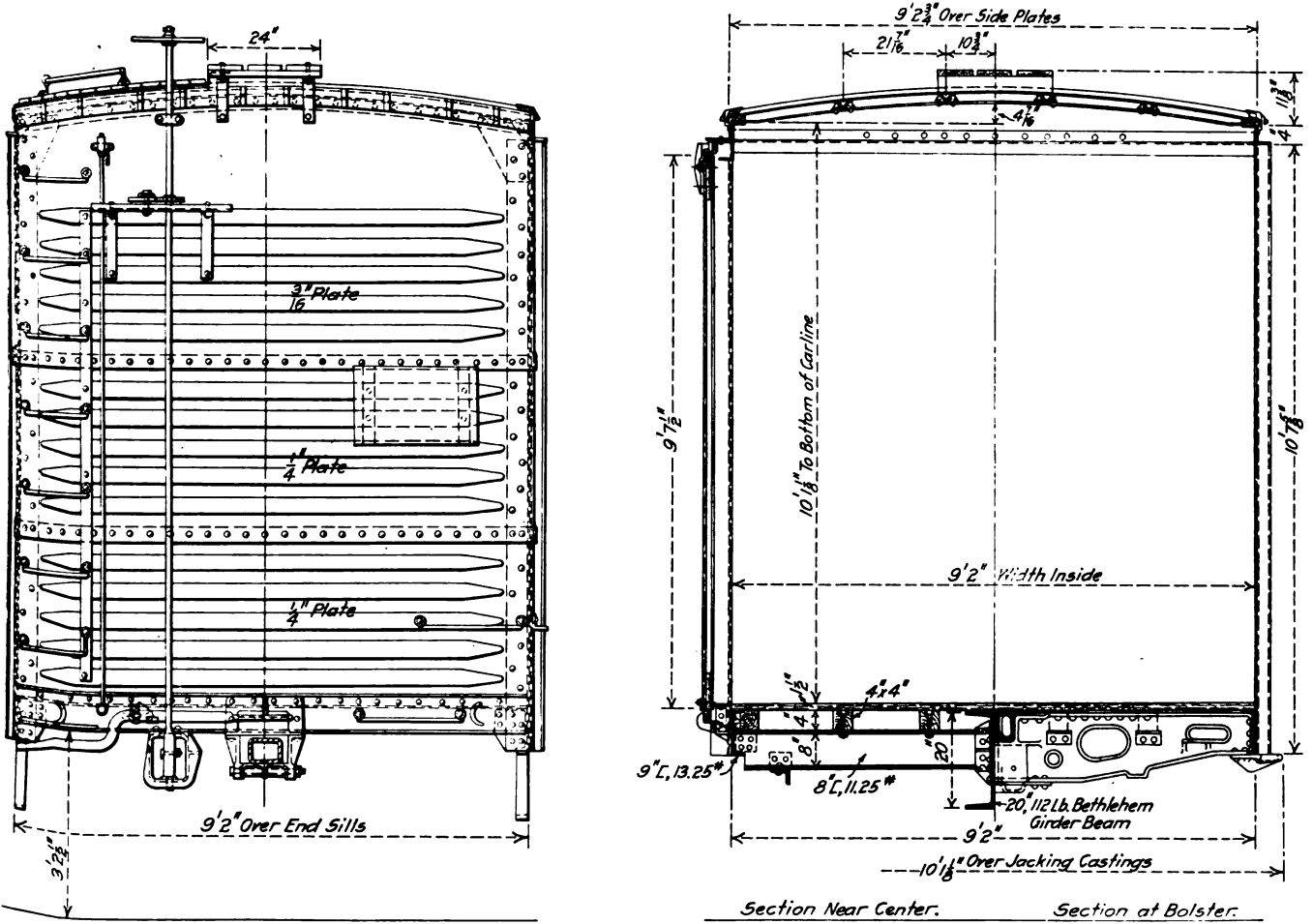

End Elevation and Cross Sections of the Automobile Car

designer that a considerable portion of the weight of the lading should be carried by the side frames of the car. The end sills are 8 in., 13.75 lb. channels and the side sills are 5 in., 11.6 lb. Z-bars. There are 6 in., 8 lb. channel diagonal braces between the

brake beams, Carmer coupler release rigging, Vulcan cast steel truck side frames, Camel door fixtures, Miner draft rigging, National malleable journal boxes, Buckeye cast steel truck bolsters and Miner gravity truck side bearings.

STEEL FRAME BOX CARS FOR THE ILLINOIS CENTRAL

The Illinois Central has recently received 5,000 steel frame box cars which were built by the American Car & Foundry Company, the Western Steel Car & Foundry Company, the Standard Steel Car Company and the Haskell & Barker Car Company. These cars are of the outside frame construction and have a capacity of 80,000 lb. All the cars are equipped with steel roofs. The cars are 41 ft. 5 in. long over the end sills and 40 ft. 6 in. long inside of the sheathing. They are 8 ft. 9 in. wide over the side sills, and 8 ft. 6 in. wide inside of the sheathing. The inside height is 8 ft. 4 in. from the top of the floor to the bottom of the carline at the side. The cars weigh approximately 40,000 lb. each.

The underframes are made up of structural and pressed steel shapes. The center sills are of the fishbelly girder type, having

deep in the center. They taper to the side sills and are riveted to the webs of the center sills and the side sills. These members are reinforced at the top by 3 in. by 2½ in. by ¼ in. angles, and at the bottom by 3 in. by 2½ in. by 5/16 in. angles. Cover plates measuring 8 in. by ¾ in. by 6 ft. long, are secured to the top flange, and pressed steel gussets are used to reinforce the cross bearers at the center sill connection in the deepest part of the fishbelly girder.

The floor supports are 4 in., 8.2 lb. Z-bars connected to the side and center sills by 4 in. by 3 in. by ¼ in. angles. The draft arms are pressed steel sections ½ in. thick, and are spaced 12⅞ in. between the webs. They form a continuation of the center sill, and are riveted to the end sill as shown in the drawing. There are two intermediate stringers of 3 in., 6.7 lb. Z-bars and two center stringers of 3½ in. by 3¼ in. yellow pine. The intermediate stringers are secured to the crossbearers and bolsters, and the center stringers to the center sills.

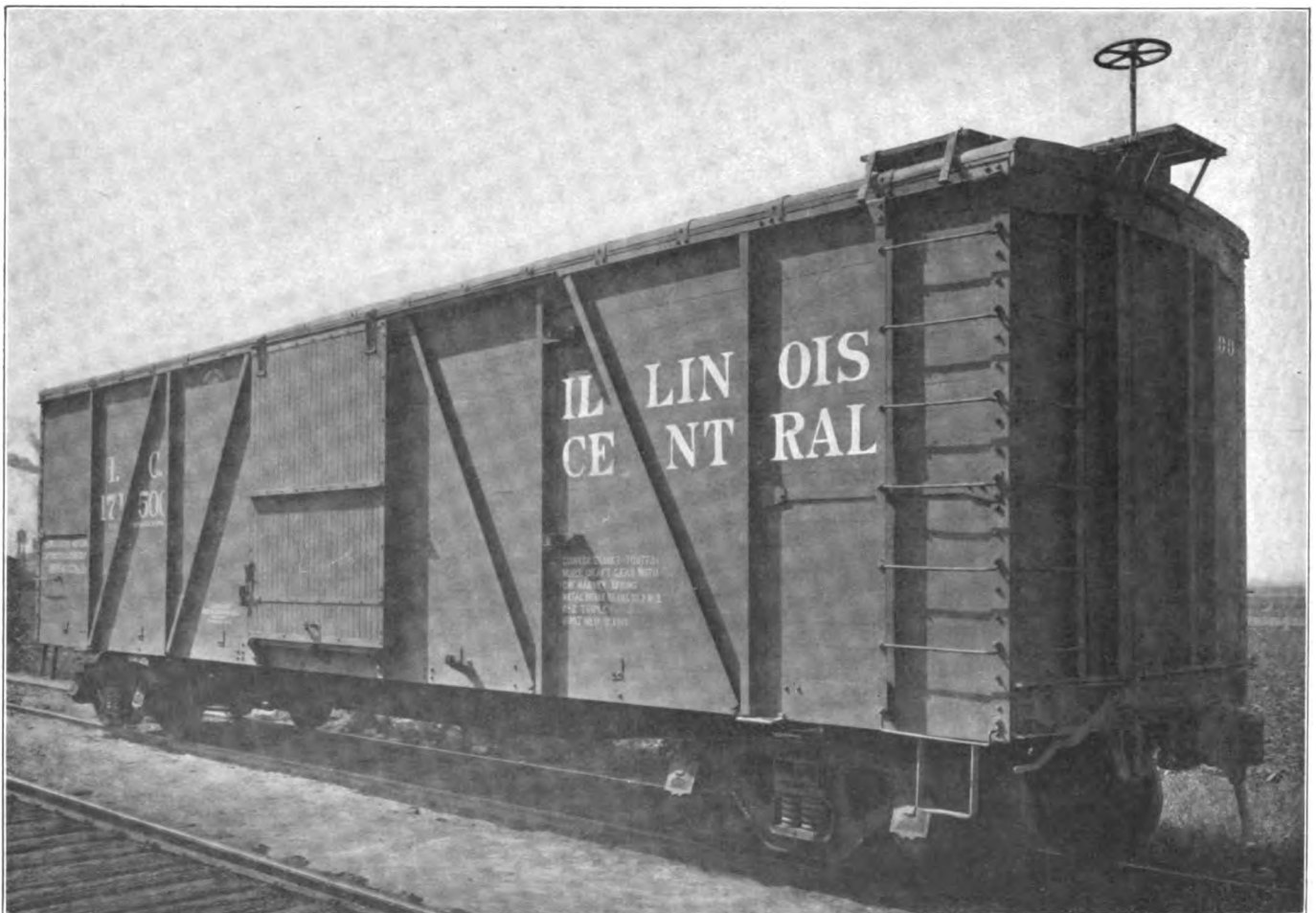

Illinois Central Steel Frame Box Car

a depth at the center of 24 in. These girders are made up of web plates 5/16 in. thick, which are riveted to 3½ in. by 3½ in. by 5/16 in. angles at the top and 5 in. by 4 in. by 5/8 in. angles at the bottom. A plate 5/16 in. thick and 19 in. wide covers the top of this girder. The center sills extend beyond the bolsters and are riveted to the draft arms. The side sills extend from end sill to end sill, and consist of 9 in., 13.25 lb. channels. The end sills are made up of 10 in., 15-lb. channels with the flanges turned outward. Diagonal braces of 4 in. by 2½ in., 8.7 lb. tees are used at each corner, extending from the bolster near the side sill to the draft sill near the end sill, being held in position by 5/16 in. gusset plates. The cross bearers are made of ¼ in. steel pressed in the shape of a pan and are 14¼ in.

The bolsters consists of two pressed steel pans ¼ in. thick riveted back to back, and to a top and bottom cover plate ¾ in. thick. Side bearings of the ordinary type are used and are located at 4 ft. centers. A variation of ¼ in. to 11/32 in. is allowed in the clearance.

The superstructure is made up of eight side posts and eight diagonal braces, all made of 3 in., 6.7 lb. Z-bars. In the end construction there are four center posts of 4 in., 8.2 lb. Z-bars and four intermediate posts of 3 in., 6.7 lb. Z-bars. A pressed steel cover plate ¼ in. thick, pressed in the shape of an angle, is riveted to the upper flange of the end sill, and is bolted to the end sheathing. The construction of the door posts is clearly indicated in the drawings, and they consist essentially of 4 in., 8.2 lb.

Z-bars. The corner posts are 4 in. by 4 in. by 5/16 in. angles. The side, diagonal and corner posts extend below the top of the side sills, and are riveted to them. The end posts extend down on the inside of the end sills. The side plates are 4 in.

posts and bolted to the roof. The floor is laid with 1 1/4 in. ship-lapped yellow pine, and the sheathing is 1 1/2 in. thick, also of yellow pine.

The trucks have a wheel base of 5 ft. 6 in. They have the

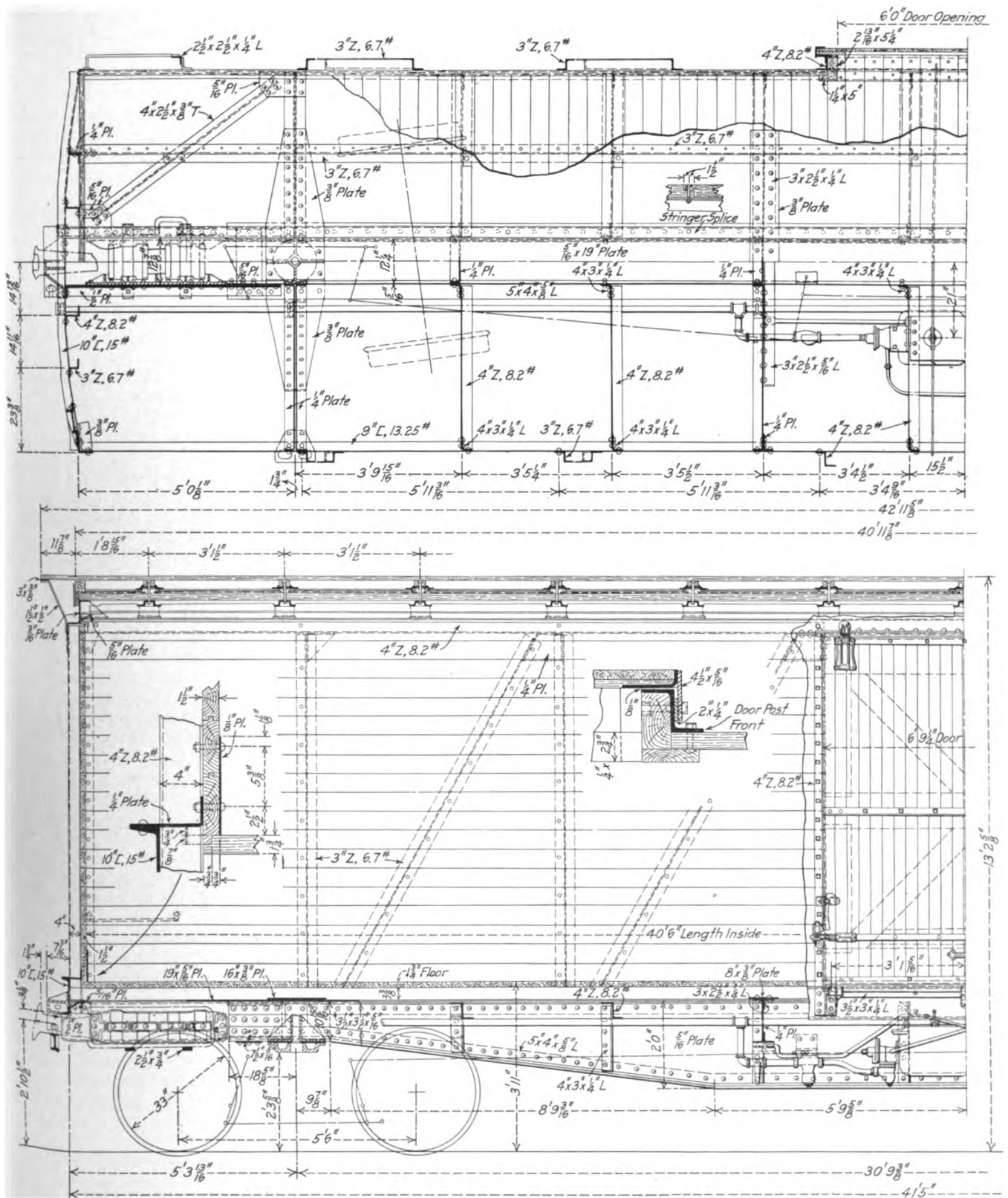

Arrangement of the Framing in the Illinois Central Box Car

8.2 lb. Z-bars. They are fastened to the side posts and diagonal braces by pressed steel gusset plates. The end plates are 3/16 in. pressed steel plates, being riveted to the outside of the end

American Steel Foundry Company's bolster, and are equipped with the Barber three-roller truck device. The Scullin-Gallagher Iron & Steel Company's cast steel side frames and spring planks

are used, with the National Malleable Casting Company's malleable journal box. Other specialties used in the construction of these cars are the Sharon coupler, Miner tandem D-963 draft

of roof failed, due to the weaving movement and torsion of the car, which loosened the nails, allowing water to run down into the car and damage the contents. Then came the practice of applying a layer of heavy plastic roofing paper between the two courses of boards. It was thought by doing this that the nails would be tightly sealed all around and this would stop the water from going through into the car. While this proved of some benefit, it did not fill the requirements. Then came the so-called torsion-proof paper roof; this roof was applied by first laying down a course of boards, usually lengthwise of the car. The roof sheets extended from the side plate to the ridge pole with the edges upturned and inserted in saw cuts in the subcarlines; then the nailing strips or subpurlines were applied and another course of boards. The weaving and torsion movements of the car caused the roof sheets to become displaced and the result was a leaky roof. Then came into use the inside metal roof with the sheets extending across the car from side plate to side plate. This roof was too rigid and the sheets gave away at the ridge pole and along the side plates. Following this came the inside metal roof with the roof sheets extending from side plate to ridge pole, the edges of the sheets being turned up and inserted in saw cuts in the subcarlines. This roof gave fairly good service and is used quite extensively at the present time, but in order to get as much inside clearance as possible this style of roof was partially abandoned and the outside metal roof came into use. This roof was applied by first laying down a course of boards lengthwise of the car with the roof sheets extending from the side plate to the ridge pole, where they overlapped, as well as along the edges. This roof did not prove satisfactory, as the weaving of the car caused the sheets to become broken at the side plates and also to unlock at the sides of the sheets, and resulted in a leaky roof. Other designs were used to some extent, but with no better results.

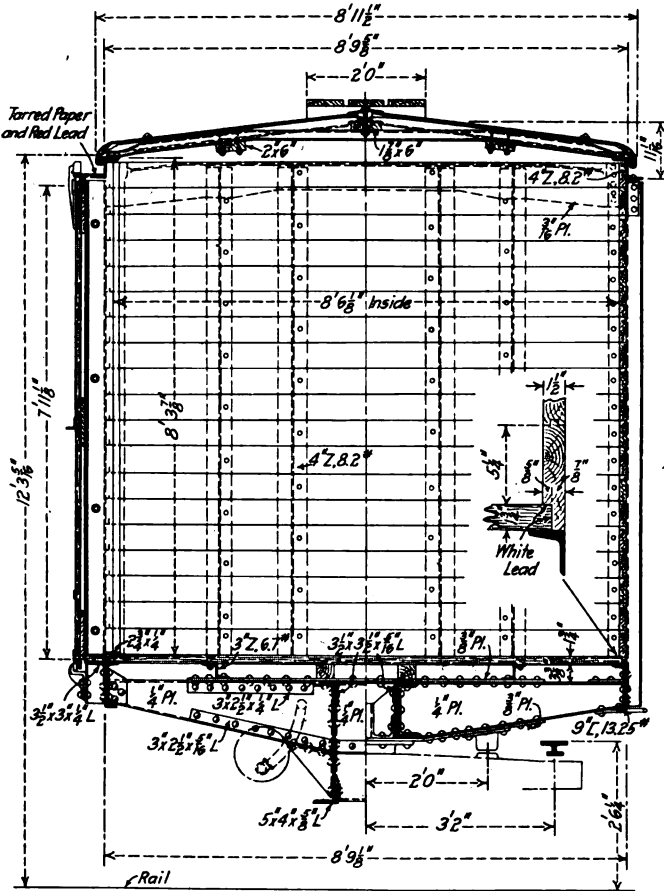

Cross Sections of the Illinois Central Car

gear, Carmer uncoupling device, the Imperial centering device for the draft gear, and Camel door fixtures.

DEFECTIVE BOX CARS

BY C. L. BUNDY

There has been a marked improvement in box car design during the past two years in order to meet the more severe service requirements due to larger locomotives, longer trains, and the more extensive use of hump yards; but in the writer's opinion still more attention should be given to efforts toward making the cars more nearly proof against lost and damaged freight. When we consider the fact that there is paid out annually by the railroads of the United States, for claims due to lost and damaged freight, approximately \$30,000,000 it would seem that railroad officers should give this matter careful consideration.

While it is a common practice with railroads to make an inspection of cars just prior to loading with cement, flour, and other freight that may be damaged by leakage, yet notwithstanding this precaution many cars with leaky roofs are loaded, and as a result claims are presented for damaged freight. More attention should be given to making roofs and doors storm proof, as this will materially reduce claims for lost and damaged freight. A careful inspection of box cars in any of the terminal yards will reveal the fact that many cars have defective roofs and side doors, and leads to the belief that these parts have been badly neglected, and in some cases poorly designed. There are few satisfactory roofs in service today.

In going back some 30 years and reviewing briefly the different kinds of roofs that have been tried out, we find the first roof to be used to any extent was the double board type. This style

In the past few years there has come into use the all metal roof which has given good satisfaction so far, and is in my opinion, the kind of roof the railways must come to in order to stop the heavy losses in claims for lost and damaged freight.

However, while leaky roofs have been responsible for most of this loss the side doors of box cars are responsible for a great deal of the trouble. A careful inspection will reveal the fact that large numbers of box cars are running with the side doors from 1/2 in. to 3/4 in. away from the side of the car, and in running against a heavy rain storm, water is bound to blow in, damaging the contents of the car. Numerous other defects in side doors will also be found, such as front door stop split, hasps broken, etc., and many doors are lost off on the road and in the yards; also, a careful inspection will reveal the fact that it is necessary in many cases to use bars and sledges to open and close the doors, a condition which should not exist. Besides this there is the liability of doors falling off and injuring trainmen, or perhaps falling against a passenger train.

In my opinion the flush type of door can be used to the best advantage, especially on cars with a steel superstructure or other designs that will not rack in switching so as to get the door opening out of square and cause the door to be inoperative. A door of this type has the advantage of being set in flush with the side of the car. It also has the advantage of moving out about two inches in opening and in case any freight is against the door, the latter moves away from the obstruction and slides by it to the open position. A door of the flush type can also be made waterproof, which is another point in its favor.

Another part of the box car that has caused a great deal of trouble is the ends. Thousands of cars will be found running with wooden ends, the end and corner posts being tennoned to the end plate and end sill. This kind of construction offers little or no resistance to the shifting of loads in switching cars and it is a waste of money to be replacing these ends as they were originally built. As fast as cars of this class give out they should be fitted with corrugated steel ends, which make a good substantial construction.

SHOP PRACTICE

TRAINING ENGINE HOUSE FOREMEN

BY R. G. GILBRIDE

Locomotive Foreman, Grand Trunk Pacific, Graham, Ont.

The choosing of a man to fill the position of engine house foreman generally has been more or less haphazard. When an engine house foreman resigns his position or is dismissed, the master mechanic may be short of material from which to choose a successor, and as a result the man selected does not have the proper training and is compelled to undergo a great many hardships that might have been averted had the appointee been given some opportunity to receive preliminary training in his new duties. Machinists who have previously handled back shop repairs exclusively, have been appointed to the position of engine house foreman, in which an entirely different set of conditions present themselves, resulting in poor service to the company.

One of the eastern Canadian railways adopted a system based on the rules which this article sets forth, and since that time has started out in charge of roundhouses a number of trained men, who have shown, with the training they have received, that they are well qualified to handle the work properly. Young men who did not develop ability to handle men during their shop training were not considered, but taken care of in the back shop work which suited their special qualifications. However, there can be no doubt that a man who has had the back shop training in addition to the special training covering the roundhouse, is better fitted to give the company good service than the man who has only had roundhouse work, or only back shop work. Road foremen of engines are trained from enginemen, train masters from brakemen, conductors and dispatchers; road masters rise from section men and section foremen; but in a great many cases mechanical officers appoint untrained men with only the experience they have gained through being first class men in heavy repair work, or in some other mechanical capacity, but which did not train them for the position of engine house foreman, resulting in trouble for all concerned through the appointee's not having a grasp of the operating and roundhouse conditions.

In selecting probationary candidates in the system referred to above, the young man selected should have had experience in the main shops as a charge hand or assistant to the foreman, or in a position where he has shown some ability in the handling of men and work. The shop master mechanic selects the men who are to be recommended for the position of engine house foreman, seeing that they are thoroughly prepared in all respects and given the necessary experience in boiler and tender shops preparatory to their departure from the main shops. The training in an engine house covers four periods of three months each. During the first three months service a man is assigned to general work which includes boiler and tender repair work.

In the second period he acts as assistant leading machinist, working as assistant to the man who holds that position in all the duties pertaining to it. It is his duty to copy the work from the work report book, assigning it to the different men, and see that this work is properly entered after the work has been done; the work of looking after the tools and tool room is also assigned to him.

In the third period he is employed in connection with the movement of engines from the time they arrive on the shop tracks until they are again turned out of the shop for service. This includes supervision of the cleaning out of the locomotives on the ashpit and the time necessary to complete this operation; moving the locomotive in and out of the shop; seeing that the washing out is properly done and keeping a check on the time necessary to do this work; looking after the lighting up of the

engines and also seeing that the work to be done on them is properly booked by the enginemen. He also makes periodical trips on the locomotives during this period to become familiar with their operation on the road, during which he makes notes of the quantity of coal and water used on the trip, weight of the train, etc.

In the fourth or final period of three months he is placed at work in the storeroom and office to become familiar with the methods of conducting the clerical work, handling the stores and the maintenance of the proper quantity of stock, as well as the system of handling the men, etc.

When he has completed his term at the engine house, has passed a written examination on the duties and work connected with the handling of engines at engine houses, and has shown himself qualified to assume the more responsible duties, his name is referred to the superintendent of motive power who then arranges to send him out as night foreman or relieving at some point.

JIG FOR DRILLING DRY PIPE COLLARS

BY F. W. BENTLEY, JR.

The renewal of brass dry pipe collars calls for considerable laying out if the holes through the pipe are irregular or zig-zag in formation. When a new collar is applied to a new dry pipe the holes are drilled through both the collar and the pipe

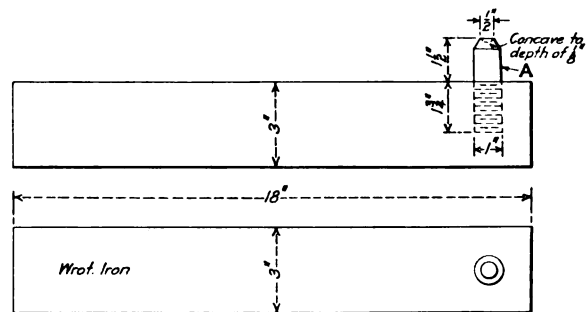

Drilling Jig for Renewing Dry Pipe Collars

in the same operation, but the renewal of the collar alone requires the laying out of the holes to match those already in the pipe.

The drawings show a simple arrangement used by the writer

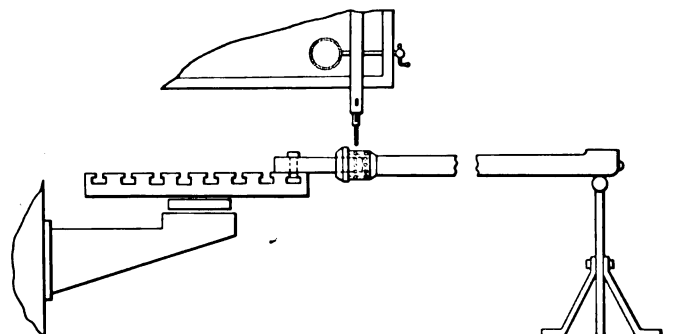

Dry Pipe and Jig In Position on Drilling Machine

which has been successful in securing accuracy and has considerably reduced the time required to do this work. The bar is bolted to the table of a drill press and the pipe with the new collar in place is laid over it. The stud *A* has a concave point

with which the drill is centered, after which the table, or radial arm, as the case may be, is clamped in position. With the other end of the pipe resting on a roller horse, the holes on the inside are dropped one after another on to the concave stud, and the holes drilled through the collar directly in line with those in the pipe. The concave end of the stud allows the drill to break through and complete the hole without obstruction. When the drilling is completed the pipe may be riveted at once.

FINISHING TANK VALVE CASTINGS

BY W. W. ELFE
Machine Foreman, Central of Georgia, Macon, Ga.

The illustrations show the method of finishing tank valve castings at the Macon shops of the Central of Georgia. For finishing the valve seat end of the casting it is set up on a drill by means of U-shaped supports and clamps applied to the flange. The

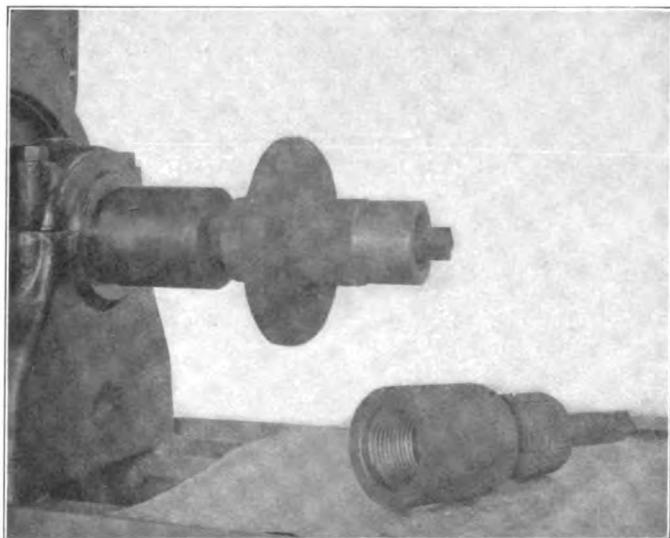

Tank Valve Casting Mounted on Expanding Mandrel for Finishing Hose Nut End

machining is done by means of a shell reamer on an arbor of machine steel which is placed in the spindle of the drill. The hose nut end is finished on a lathe, the work being supported on an expanding mandrel screwed to the spindle of the lathe. Only two sizes of these castings are used, therefore it is necessary

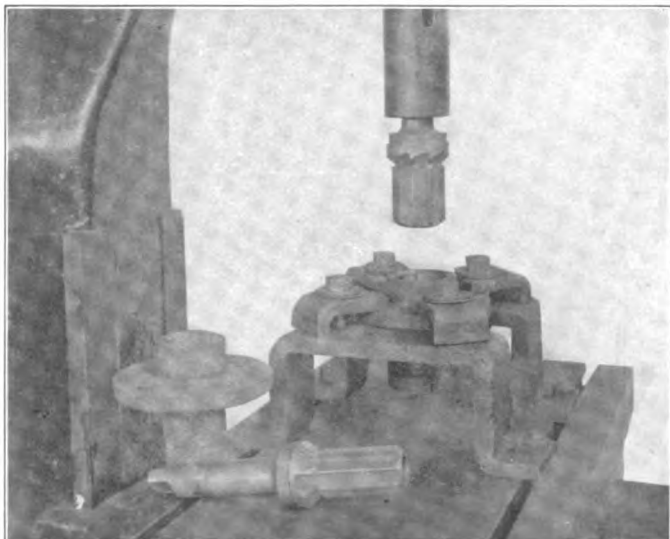

Finishing Valve Seat End of Tank Valve Casting

to have only two mandrels and two reamers to take care of this work for all classes of locomotives. The reamers, being of the shell type, may be made to fit the same arbor.

CLEANING AIR PUMPS

BY W. E. JOHNSON
Storekeeper, Chicago & North Western, New Butler, Wis.

The accompanying illustration shows a method of cleaning air pumps without removing them from the locomotives. The apparatus used for this purpose is half of an ordinary oil barrel, placed on a frame of 1/4 in. by 2 in. bar iron which is made to fit the bottom of the barrel just above the first hoop. This band is made in two parts, one part having the axles welded on, while the other part has the handle and rest. These two parts are bolted together through 1/2 in. holes drilled in the lugs on the two halves of the band. A strong solution of lye water is placed in the barrel and the pump connections to the air end of the pump are broken, fittings being applied as shown, so that the lye water may be drawn in through the inlet and discharged back into the barrel through the outlet.

These pipes extend down very nearly to the bottom of the

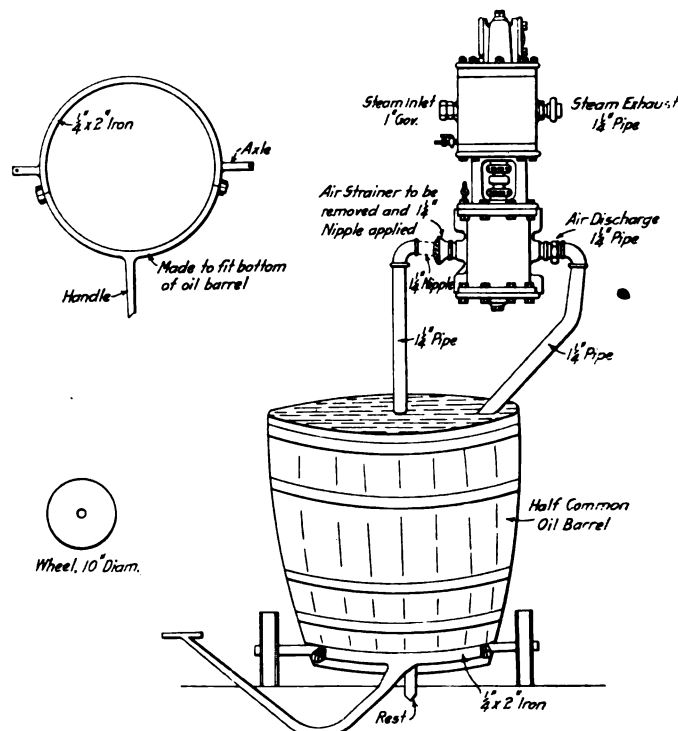

barrel and are spaced as far apart as possible, so that the refuse matter coming out of the pump will not be drawn back into it again. When all the connections have been made, steam is applied to the pump and it is run at a slow rate, drawing the lye solution into the air inlet, circulating it through the different passages and discharging it from the discharge pipe with the refuse. This is allowed to continue for one hour, and at the expiration of that time the pump is washed out by the same process with clear water. The pump is then well lubricated and placed in service. It has been found that this method is very satisfactory. The information was obtained through the courtesy of J. E. Tisdale, general foreman at New Butler.

INSPECTION.—Next to the intelligent selection of help, the inspection of the product is the most important factor of efficiency.—*American Machinist.*

REPAIRING LOCOMOTIVE BOILER TUBES

Methods Which Bring Good Results in a Shop Which Has a Minimum of Facilities for This Work

BY N. H. AHSUOLH

The handling of locomotive boiler tubes and flues in the shop is an important item of the cost of locomotive repairs. Articles on this subject have appeared recently in several journals, in which stress is laid on the use of mechanical devices to facilitate operations and reduce costs. The writer, being accustomed to achieve corresponding results with a minimum of facilities in various departments of the boiler shop; and knowing also, that there are many other boiler foremen working under similar conditions,

hand. After it has been run the required length of time to properly clean the tubes, they are dumped from the bottom on inclined rails leading to the floor where they are ready for inspection and sorting.

Fig. 3 is a floor plan of the flue shop, an interior view of which is shown in Fig. 4. It will be noticed that the machines are set very close together because of the absence of facilities for handling the tubes. The space is so limited that it is necessary to finish tube work as it leaves the rattler; it is not prac-

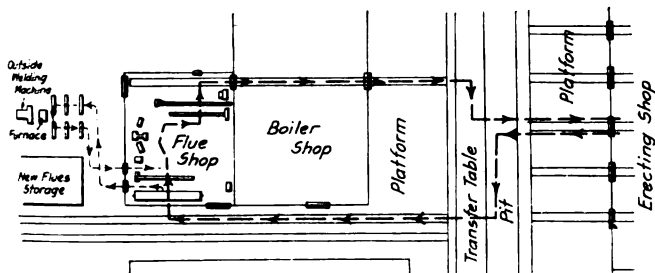

Fig. 1—Diagram Showing Course of Tubes Through the Flue Shop

will endeavor to show how tubes may be efficiently handled from the locomotive, through the flue shop and back to the locomotive entirely by hand.

It may be well to state that in the particular shop the arrangement and operation of which are to be described, all 2 in. and 2¼ in. tubes are iron and are repaired with iron safe ends, while all 5½ in. flues are iron but are repaired with 4½ in. steel safe ends. Fig. 1 shows the layout of the shop buildings

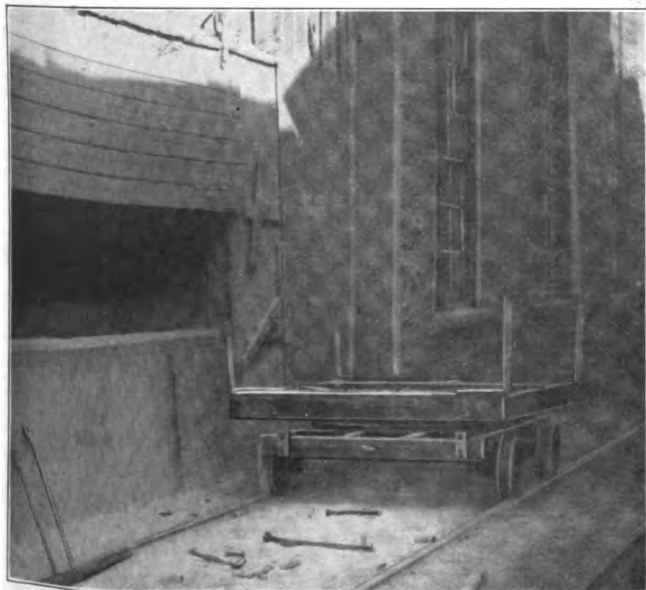

Fig. 2—Rotary Car on Which Tubes Are Carried to the Rattler

adjacent to the flue shop and affecting its operation. As the tubes are ready for removal from a locomotive in the erecting shop, a car of the type shown in Fig. 2 is placed ahead of the locomotive, on which the tubes as they are removed from the boiler are loaded. The loaded car, which has a capacity of one full set of 460 tubes 2¼ in. in diameter, is then run on the transfer table and moved to the track leading to the rattler. The rattler is of the barrel type, is run dry and is loaded by

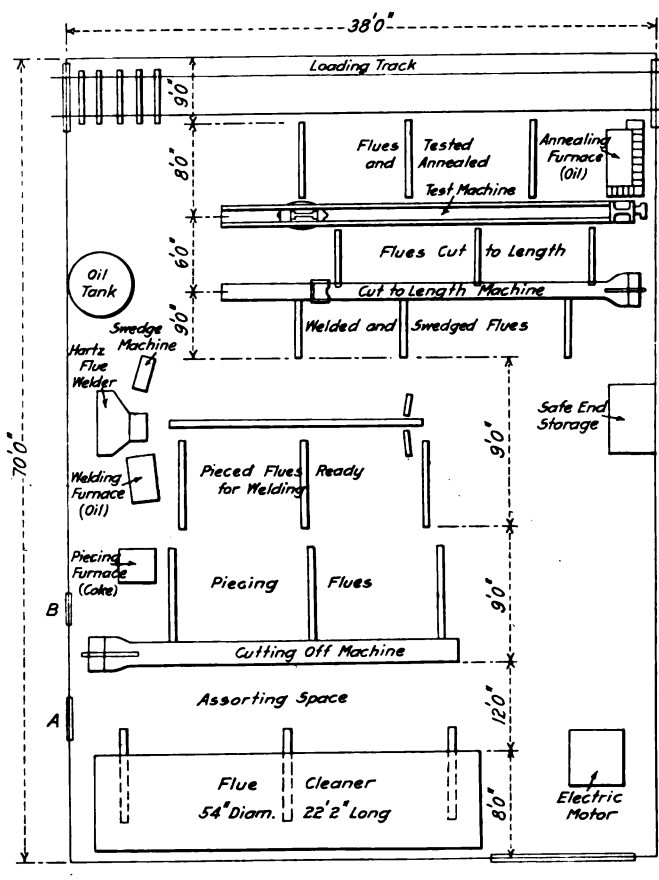

Fig. 3—Plan of the Flue Shop Showing the Location of the Machines

ticable to finish a part of one set and then store the remainder while finishing all or part of another set.

It has been noticed upon inspecting tubes as they come from the rattler, that those having from three to eight safe ends are badly pitted on the safe ends, while the body of the tube is still perfect. Where this condition is found, the old safe ends are cut off and the remaining part of the tubes restored to the required length by welding on an intermediate piece similarly cut from another old tube. These intermediate pieces are of three lengths: 21 in., 40 in. and 60 in. A new safe end 7 in. long is then welded on the end of the intermediate piece, the finished tube having only two welds. This practice has very materially reduced engine failures due to burst tubes.

After tubes are inspected and sorted, those to be scrapped are thrown out of door A, Fig. 3, to be loaded on scrap cars,

while those to be safe-ended are piled at the cutting-off machine.

After the tubes are cut, those requiring intermediate pieces more than 21 in. long are loaded on a wagon and moved to a flue welding machine which is placed about 50 ft. from the flue shop, in the material yard. This machine, which is shown in Fig. 5, is a combination of a homemade rivet forge and a No. 2 Boyer rivet buster placed over a welding die and mandrel. The brickwork in the rivet forge was altered, and the air pressure used in the rivet buster reduced to 40 lb. per sq. in. The forge and rivet buster are set in line, so that while one end of the piece to be welded is heating the other end is on the mandrel, between the dies. When the proper welding temperature is reached, the tube is pushed through the fire and the weld made with the rivet buster, which is operated by a pedal. As the weld is completed in a very short time, the part of the tube in the furnace is not seriously affected by the fire.

After a tube is welded it is withdrawn and laid by itself until

which is bolted a piece of $\frac{3}{4}$ in. plate having a punched hole 3 in. in diameter through its center. In placing the end of the tube against the stop the swedged portion is passed through this hole, where its rotation against the rough punched edge of the hole removes all scale and dirt leaving the end which receives the copper ferrule in the back tube sheet smooth and clean.

After the tubes are cut to length, they are given a hydrostatic test. The machine for doing this work is adjustable for various lengths of tubes. It consists of a wooden trough with a cylinder at each end; the cylinder at the rear end does not close the tube until it is full of water, after which the other cylinder increases the pressure in the tube. This method insures the removal of all air from the tube before the test is made, after which the front cylinder raises the pressure in the tube from 100 lb. per sq. in.—the water line pressure—to 300 lb. or more, depending upon the air pressure. Defective tubes are thrown

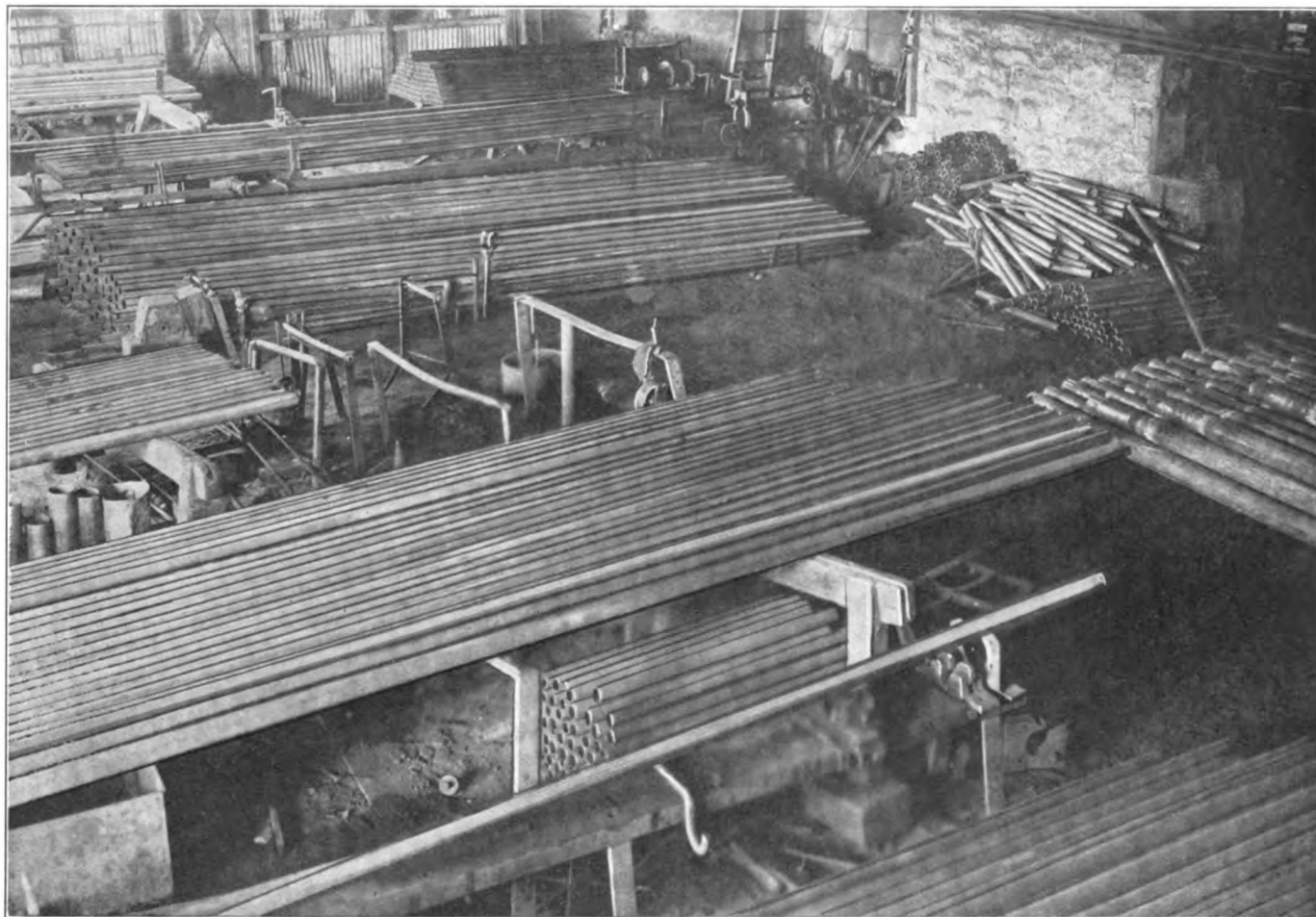

Fig. 4—Interior of the Flue Shop Looking Toward the Annealing Furnace and Loading Track

cool, when it is piled. It has been found that if tubes are piled while the welds are still red hot, they will be bent when cold, due to the contracting of the exposed surface sooner than that next to the other tubes in the pile. After the intermediate pieces are welded on, the tubes are loaded on a wagon and returned through the window *B*, Fig. 3, to follow the course of other tubes through the shop.

The tubes next are placed at the piecing furnace where the ends are expanded and seven inch safe ends inserted. They are then piled at the welding furnace and welded by a Hartz flue welder. The swedging of the ends is done at the same heat and the tubes are then piled back of and to the right of the cutter, ready to be cut to length. This machine has an adjustable stop to govern the length of the tubes, against the upright leg of

out and those which withstand the test are piled at the annealing furnace.

The annealing furnace consists of a back wall and a small end wall to protect the testing machine from the direct radiation from the fire. The tubes are piled up with the ends about two inches from the back wall; the burner is opened and the flame being confined to the 2 in. space, the ends of the tubes are soon raised to a red heat. About 150 tubes are annealed at one time. As fast as they are heated the tubes are placed on the push car shown in Fig. 4 in the background. When loaded this car is pushed out to the boiler shop, where the tubes are transferred to the rotary car shown in Fig. 6. This car is then passed across the transfer table to the track in front of the engine from which the tubes were removed.

Due to the fact that engines in the erecting shop are headed south while the flue shop was originally laid out for engines headed north, it is necessary to turn all tubes end for end before they are placed in the rattler and again after leaving the flue shop. This is taken care of by the ball bearing rotary cars shown in Figs. 2 and 6.

Superheater flues 5½ in. in diameter are handled by the same methods, and follow the same course through the shop as the 2¼ in. tubes, the various machines being adjusted to suit the larger diameter. In cleaning, about six or seven are placed in



Fig. 5—Outdoor Welding Machine and Furnace for Piecing Short Tubes

the rattler with a load of 2¼ in. tubes. By this method the splitting of ends formerly experienced has been eliminated.

Steel safe ends 4½ in. in diameter are cut the required length, then heated and scarfed by hand. The flues are cut on the 4½ in. end and belled out to receive the safe end. The scarf is then made by chipping the outside corner of the belled portion of the tube as shown in Fig. 7. This method of scarfing eliminates the use of a lathe in the machine shop, so that all work on the flues is taken care of in the flue shop. A liberal amount of borax is used while making the welding heat and only one heat is taken, the 4½ in. ends of the flues being heated only twice

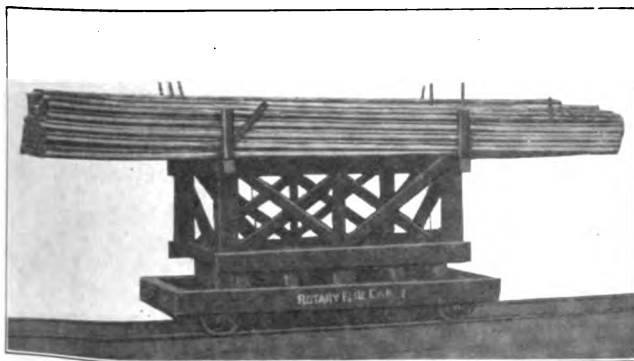

Fig. 6—Rotary Car for Transporting Repaired Tubes to the Erecting Shop

while in the shop: once at the piecing furnace and once at the welding furnace. The heating of these large flues is always accompanied by a wasting of the metal and by keeping the number of heats to a minimum a much better flue results. These flues are cut to length, tested, annealed and loaded in the same manner as the 2¼ in. tubes.

The operations described are taken care of by a regular flue shop force of four men, a fifth man being required only when handling 5½ in. superheater flues. The moving of the tubes loaded on the special cars shown in the illustrations, from the engine to the rattler and from the shop back to the engine, is

done by the general shop labor gang. The output per month averages about as follows:

- 4,500 2 in. and 2¼ in. tubes;
- 100 5½ in. flues;
- 100 3 in. and 4 in. miscellaneous tubes.

This output is equivalent to approximately 6,000—2 in. or 2¼

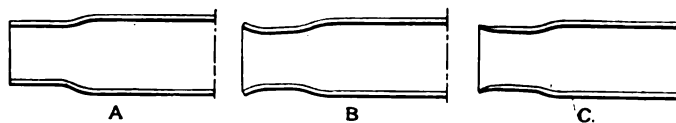

Fig. 7—A—Superheater Flue Swedged to 4½ in. Diameter; B—Flue Belled Out to Receive the Safe End; C—End of the Flue After Being Scarfed by Chipping.

in. tubes and is handled at an average direct labor cost of \$300 per month, or at an average rate of five cents per tube.

The average number of tubes removed from boilers as a result of leaks during the hydrostatic test is less than one per boiler and there have been no leaks or other defects in the 5½ in. flues either during the hydrostatic boiler test or in service afterwards.

ENGINE HOUSE REPAIR WORK*

BY M. VALLEN

General Foreman, Southern Pacific, Carlin, Nev.

An engine house, to be managed to its highest efficiency, must, in the nature of its equipment, be up with the highest standards of the times. A general repair shop, in order to turn out the largest possible amount of work in first-class condition, must necessarily be equipped with the latest facilities, such as traveling cranes and improved machinery. An engine house on the other hand, must be equipped with good boilers, water pumps, air compressor, serviceable lathes, turntable, sanding device, and fuel facilities, in order to successfully handle the power. It is also necessary that good drop pits be provided; that the house be well lighted, and, if the climatic conditions require it, in winter it should be fairly well heated. It should be kept in a sanitary condition at all times. This, I believe, has a very great effect for efficiency among the men.

The engine house equipment should be frequently inspected and repair parts kept in stock ready for an emergency, as the plant cannot be successfully operated without the equipment in proper working order. The turntable should receive its share of attention in the line of maintenance, such as oiling the operating machinery and also the bearings. All tools should be thoroughly inspected and their condition kept up to as high a standard as possible, and the men in the various vocations should be impressed with the idea that it is their duty to see that defective tools are reported. The engine house foreman should know the condition of every engine under his charge, and the date of the last general repairs, and a record should be kept of such dates.

In the organization of an engine house of any size, provision should be made for an assistant foreman, a boilermaker foreman and a clerk. The boilermaker foreman should determine the condition of the fireboxes and tubes of each engine and report it to the engine house foreman, and I also believe it would be good practice for the foreman occasionally to personally inspect the interior of fireboxes and the condition of tubes. The assistant foreman should have charge of the various mechanics. The foreman knowing the condition of each engine, should plan the work and select the best opportunities for making unusual and heavy repairs. He should also co-operate with the store-department toward keeping the standard repair parts in the store room, avoiding the waste of producing them with the

*Entered in the competition on Engine House Work, which closed July 15, 1914.

inferior machinery available at most engine houses; in most cases, the parts can be manufactured in the general shops many times cheaper than is possible in the roundhouse. Delay to the work on the engines will be prevented by having as many necessary repair parts as possible in stock, which will necessarily keep the engines in service a greater proportion of the time.

The engine house foreman should at regular intervals advise the master mechanic, or other officer, regarding the condition of the engines, and how long they can be kept in service without general repairs. The boilermaker foreman should be thoroughly familiar with the ability of each man in his charge, know to which class of work each one is best suited, and that the necessary tools are available and in good condition. He should instruct his men that the standard of the road in the line of tools should be strictly adhered to; that proper prossers or rollers are used and see that the men thoroughly understand the work which they are doing. This is of great importance, as a boilermaker not thoroughly understanding his work may do considerable damage to a boiler. It is also of great importance that hostlers, fire cleaners and other laborers connected with the turning of engines be trained to realize the importance of their work and what it means to have engines turned in the least possible time. Hostlers should be instructed how to properly use injectors and care for the fire while an engine is in their charge in order to prevent unnecessary work which might be caused by improper handling.

As much work as possible should be specialized. A blackboard should be installed in a conspicuous place and marked with the various special work into which the repairs of locomotives may be divided, such as air brake, boiler work, etc., and as many other special duties as may be desired. The men for these various duties should be carefully selected. The air brake man should necessarily understand the operation of the air brake and also how to make proper repairs; for instance, if the brakes are reported not setting, he should know what defects in the air brake apparatus will produce such a defect.

The man in charge of boiler appurtenances should be thoroughly familiar with the Interstate Commerce Commission requirements and should also understand the working conditions of injectors, lubricators, etc. If an injector is reported not working, the cause should be determined and not a new injector immediately applied, where perhaps a few slight repairs will answer the purpose. The testing of steam gages and the setting of safety valves should be among his duties and he, in conjunction with the boiler inspector, should see that all such work as is required by the Interstate Commerce Commission regulations is done, the boilers washed out, as well as any other inspection or repair work. This will help greatly in keeping the engines in service and also prevent the frequent waste of fuel which occurs when a boiler is blown off.

The duties of the cellar packer should not be lost sight of. Much can be accomplished by proper attention to this work. The cellar packer should be so trained as to be able to fit up engine trucks, trailer and tank brasses and should also know how to adjust driving wedges. This work should be under his care, and he should thoroughly understand what effect a tight wedge may have in producing a hot driving box, and how an improperly fitted bearing will affect a journal. A tanksmith should be employed, whose duties should be to maintain all tank wheels, springs, safety appliances on the tank and engine, see to the application of all brake shoes on the engine and tender and the application of all engine springs. Reliable and steady men should be employed on this class of work and the wages paid should be good, as the work is heavy and requires much physical exertion.

A man thoroughly familiar with valve gears should be used when work of this nature has to be done. Such other work as valve rings, piston rings, links, etc., should also come under his charge as his time will not be constantly occupied in setting valves in the ordinary roundhouse. A man who thoroughly

understands rod work should be assigned to do all such work. This will generally keep a man busy in a roundhouse of any size. Such work as packing piston rods and valve stems, the maintenance of flange oilers, etc., should be assigned to a special man, who, with the experience which he will gain, will show a great saving in the maintenance of these parts. Whatever additional force is required, such as men for general repair work, changing engine truck wheels, taking up lateral motion in trailers, refitting binders and the various other classes of work reported, should be kept as all around running repair men. If enough work is done to justify one or two machine men, they should be employed, and in addition to the necessary machine work they should make repairs to tools.

The roundhouse clerk should keep a record of all annual and monthly inspections of locomotives and boilers, also the dates of washout. I believe it is a good practice to have a regular period of time between washouts. He should also keep record of the various piston inspections, the removal of tubes, the removal of lagging and the inspection of the interior and exterior of boiler barrels, and such other office records as may be assigned to him.

Hostlers should be made to realize that as soon as an engine arrives it should be placed in the roundhouse with the least possible delay. The work report should be immediately copied; this should be done by the assistant foreman, who has immediate charge of the repair work, and each item distributed to the various men. The numbers of engines requiring washout should be marked on the board during both the day and night shifts by the foreman or inspector in charge. Boiler washers should thoroughly understand the importance of cooling a boiler properly before washing, at points where cold water is used, and should be made to realize the importance of keeping the boilers free from scale and washout plugs clean and in good condition.

Care should be exercised as to doing all the work booked by enginemen. Mention might be made of the frequent report "engine not steaming." An engine which has given satisfactory service as to its steaming qualities at previous times should not have the size of its nozzle tip reduced or a heavy bridge put in it, but the possibility of other defects which will prevent an engine from steaming freely should be thoroughly investigated. In many cases after the tubes and the crown sheet are thoroughly cleaned a great difference is experienced in the steaming qualities of an engine which was previously reported as not steaming.

PNEUMATIC FLUE CUTTER

BY W. S. WHITFORD

General Foreman, Chicago & North Western, Milwaukee, Wis.

The illustration shows a flue cutter which has been used for some time, but which as originally constructed required the use of a special motor supplying air to the cutter through the spindle. The end of the spindle was redesigned by the writer in order that knuckle jointed shafts and any type of motor may

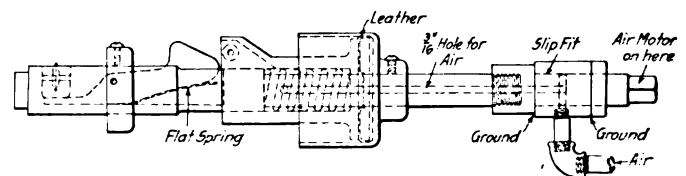

Pneumatic Flue Cutter Altered to Take Motors of Any Type

be used. As now arranged, air is supplied to the flue cutter independently by means of the carefully fitted sleeve and ports in the spindle leading from the circumference to the $\frac{3}{16}$ in. air passage on the center line. This device is very useful in cutting out flues behind steam pipes, which may be done without the necessity of removing the pipes.

RIVETING IN STEEL CAR CONSTRUCTION*

A Brief Discussion of Rivet Manufacture; Operations Which are Necessary to Secure Tight Rivets

BY H. A. HATFIELD

General Foreman, Canadian Car & Foundry Company, Montreal, Que.

II.

Poor riveting may result from careless work: neglecting to change dies often enough, poor judgment of rivet lengths and other shortcomings for which the riveting gang is accountable. But frequently the greater part of the trouble is due to worn rams and adjusting screws. Once either wears, the dies will throw sideways, since the rivet will bend easier than it will upset. The head formed will be off center and will cut across the grain of the stock, thus losing a great part of its strength. On close work, if the bottom of the die, the yoke of the machine or the "bull nose" projects far enough to hit before the head of the rivet is in line with the center of the cup, the edge of the cup will cut the head and spoil the rivet. When the conditions are such that a "bull nose" is used care must be exercised that it is not bent by the repeated heavy pressures, so that the rivet heads are out of line. Old machines that are sprung slightly may be corrected by a special die holder made with the shank off center, or bored eccentric to bring the die faces in line.

Stationary machines are of two kinds, column and pit riveters. The latter is generally used for center sills, etc., it being more convenient to handle large work when it is suspended. The machine should be so placed that an air hoist or chain block may be hung from an overhead trolley or jib crane by which the work may be supported. For smaller

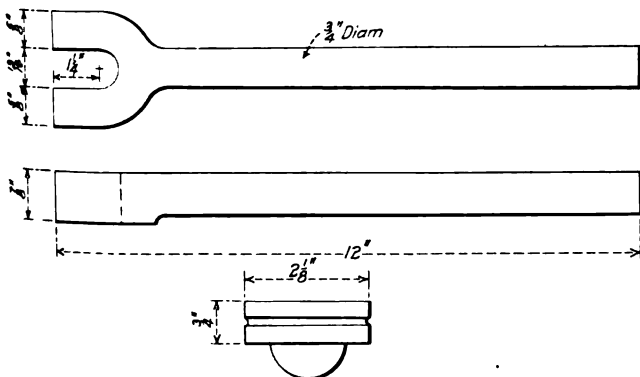

The "Coaxer" for Drawing Plates Together, and Special Tool for Driving Flat or Countersunk Rivets

machines a very convenient sling is made of a small endless chain, which is caught over the hook of the block and around the work, to support the end farthest from the die.

On any but the very lightest work, it will be found desirable to use four men in a gang; the fourth man enables the gang to maintain a speed that would be impossible with three men. The machine operator should have some mechanical ability and a knowledge of the machine he is handling. His first helper must be strong and active, as he has the greater part of the heavy lifting to do. The sticker and heater should be bright, active fellows, as their speed and skill in furnishing the rivets control the output of the gang.

Each gang should have a complete set of dies and its own outfit of tools, including a medium weight sledge, two stickers, hammers, wrenches of various sizes, drift pins, bolts, nuts, washers, etc. A tool known as the "coaxer" is used to

squeeze the plates together when they are being riveted without having been well bolted together first. It resembles a wrench, the jaws being 7/8 in. thick. The rivet is stuck from the bottom up through the pieces to be riveted and the coaxer is slipped over it. The die coming down presses on the jaws of the coaxer and squeezes the plates together, then the ram is lifted enough to allow the coaxer to be withdrawn and the rivet is formed by a second application of the air. The gage is tried again and if it fits, the remaining rivets may be stuck from the top and rapidly driven.

When it is necessary to drive an occasional flat or countersunk head in a run of button heads it can be done without changing dies with the tool shown in the illustration. This is made of high speed steel with a button on one side to fit the cup of the die already in the machine. A groove is turned

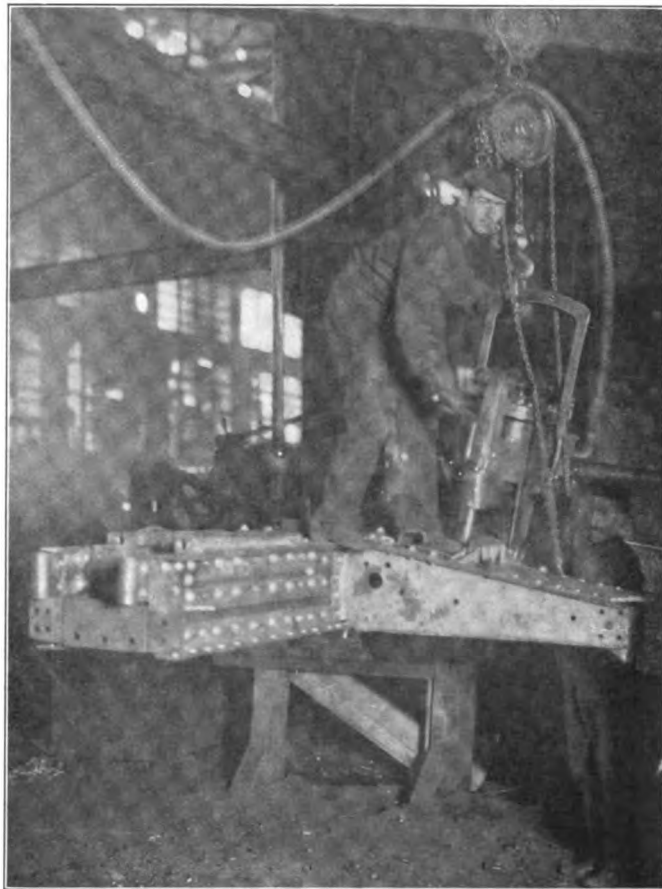

A Jaw-Riveter In Use on an Underframe, Showing Method of Suspension

around the body in which a wire handle may be secured. As the tool is necessarily small, it should be hardened, otherwise it will distort with the pressure and heat.

For work too heavy or unwieldy to handle to the machine, a yoke riveter may be used similar to the column riveter, but without the lugs used for fastening the latter in position. On freight car underframes some variation from the standard shape of rivet head is permitted, and a light, strong machine, known as a jaw-riveter, is used. The heads made by this

*For Part I see *Railway Age Gazette, Mechanical Edition, January, 1915, page 33.*

machine have a slight ring on one side owing to the fact that the motion of the jaw does not carry the die on a line parallel to the center line of the rivet and the outside edges of the dies are a little further apart than the inside edges when the rivet is finished. This can be avoided to a certain extent by making special dies so designed that when the rivet is completely formed the die faces are parallel. These machines are easily handled and are very speedy. They are strong for their weight, since the gap is very small, and the leverage is large in proportion. A free running chain block of at least two tons capacity should be used to suspend this machine. The reason for the large size of this block will be understood when it is known that frequently it has to support a portion of the weight of the work owing to the fact that the dies are often slightly high and lift in closing. Care is necessary to get the height of the top die just right, for if the machine hangs on the rivet, it will spoil the shape of the head and mark the plate.

The ease and speed in handling suspended work or a suspended machine depend greatly upon the design of the trolley and the track used. For medium weights a two-wheel trolley may be used, but for heavy work four wheels are preferable, two wheels tending to jam and move in jerks. The length of wheel base and increased bearing surface make the four-wheel trolley run smoothly with a minimum effort and it takes the joints in the track without difficulty.

PNEUMATIC HAMMER RIVETING

The importance of properly heating the rivets for machine riveting has been strongly represented. It is of still greater importance when the rivet is to be driven with a pneumatic hammer, since it must be at such a temperature that the shank will upset with the impact of the hammer. Unless the hole is thoroughly filled the rivet may be jarred loose; its holding power will then be reduced to the bearing pressure of the heads on the plates, produced by the contraction of the rivet material in cooling. Consequently, the first requirement of any riveting gang is a properly designed rivet furnace. The present market price of fuel oil makes it of the utmost importance that all the work possible be obtained from it. The furnace must, therefore, be built for the work, and the burner properly installed, as well as operated with intelligence.

Something of the art of heating should be taught the heaters instead of leaving the mastering of this important operation entirely to their experience at the expense of many gallons of fuel oil wasted and tons of rivets burnt. It is impossible to obtain intelligent operation while the present practice of hiring small boys for heaters prevails, hence it would seem advisable to so arrange the prices for this work that men capable of understanding instructions could be secured. It should first be shown the heater that oil will not burn in the liquid state, and that the burner is employed to break it up and mix it with the air necessary for combustion without waste. The second lesson should deal with the handling of the burner to obtain the proper mixture of oil and air; it should show how if too much oil is turned on it will smoke, and if too high air pressure is admitted to the burner it will carry the particles of oil beyond the point where the work is to be done before they can be raised to the burning temperature. Best results are obtained with a short white flame that a heater will soon learn to recognize. He must also learn to know the proper temperature of the rivet by the color, and the nature of a burnt rivet.

The furnace should be located as close as practicable to the work and the shortest possible length of time intervene from the moment the rivet leaves it till it is headed; hence the gang must move quickly and complete each move in a positive manner, there being no remedy for a loose rivet but to cut it out and replace it.

The heater's comfort should be looked after, and some arrangement made so that he may approach the furnace without

having to bear the direct heat from the doors. Different arrangements have been tried with success. Baffle plates and perforated air pipes below the door, to blow the heat upward, or water pipes above the door, perforated so that a sheet of water falls across the baffle plate and keeps it cool, are both very good methods. The shop windows should be painted or shaded if the sun shines on the furnace during the hot part of the day, as the two heats will sicken the toughest heater.

The number of rivets the gang has in a run being laid out for them, they should always proceed in the same rotation so that the heater will always know what length and diameter of rivets to send along, otherwise considerable time may be lost while the heater and sticker signal to one another. Of course, if the punching was inaccurate and the hole very much enlarged by the reaming, a longer rivet than usual will be required to fill it up, and signals must be given. A simple code for the purpose should be adopted and taught to each new heater.

Next in importance to the furnace installation is the supply of rivets and the method of keeping them at the furnace. Once the gang has had a full day on a run no difficulty should be experienced in obtaining the right size and length of rivets from the source of supply. The amount allowed each heater should be carefully checked and an investigation follow any unusual demand. The supply should be controlled by one man, who will report the amount per day supplied each furnace so that the proper sizes and lengths may be made as required.

Small bins built of steel should be placed at each furnace, the number of compartments corresponding to the number of different rivets in the run. For machine riveters usually a great number of the same size rivets are used, while on the shipping track it may be necessary to have six or seven lengths and possibly two or three diameters. In the first case there may be only two large compartments in the box or bin, while in the latter case it may have to be two tiers high to accommodate the number required. The construction should provide sufficient room for dumping the supply of rivets directly into this bin, and allow the heater to get them out with a shovel from the bottom.

Small rivets should be heated in a muffle furnace. If the quantity of rivets required does not justify building such a furnace, a short length of heavy pipe of a large diameter may be used, one end being plugged, or a couple of fire bricks may be placed so as to keep off the direct flame, though this method does not furnish very clean rivets.

For the safety of those working around him and persons passing by, the heater should be impressed with the necessity of looking before throwing the rivet to the sticker. The pause should be of sufficient length for his eyes to become accustomed to the light of the shop after the glare of the furnace.

The sticker should be taught the signal code and he should know the proper temperature of the rivet. He must be quick in his movements and adept at catching rivets. For this purpose a can should be furnished and the practice of stopping the flying rivet with the gloved hand forbidden, as the effect of burns to the hands or scale in the eyes may prove serious. The can should be made of heavy, galvanized iron, special care being taken to have the handle comfortable to hold, and stiff enough to stand up under the blows received. If the sticker can reach his work from the floor, a triangular device made of thin plate may be used. It serves the double purpose of catching the rivets and protecting the floor from the heat. The tools provided the sticker include a pair of short tongs, which can be used with one hand for picking up the rivets, a hammer for knocking off scale or driving the rivet into the hole, and a wrench, it being his work to remove the assembling bolts.

In car construction the variety of dolly bars is great and new ones must be made to suit any special requirements, but the general principles are the same, new bars usually being modifications of some one of those shown in the engraving. The straight

dolly may be made from a solid bar of mild steel and the cup forged in one end, or it may be made so that the snap or set used in a pneumatic hammer may be placed in the end. The latter is the better method, as the snap having had a machine finish forms a truer head, and having been hardened is less liable to distortion and wear. By changing snaps, this bar does for all sizes of rivets. The drawing shows the body of the bar somewhat smaller than the ends, the advantage gained being in the purchase obtained for the forward hand against the enlarged front end.

Very often it is necessary to offset the dolly to clear some obstruction in direct line with the rivet, or to place the buckler in

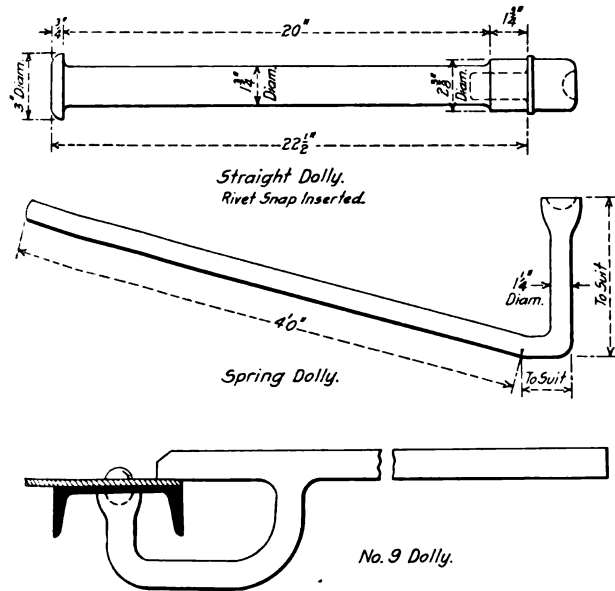

General Types of Dolly Bars Used in Steel Car Construction

a more convenient position. The straight dolly for a $\frac{5}{8}$ in. or $\frac{3}{4}$ in. rivet should weigh 30 lb. If the conditions permit this length, it should be forged from a 2 in. round bar 26 in. long. The spring dolly is used when it is possible to jam a bar between the rivet head and some part of the car in direct line with the rivet. If possible a handle is attached. Bars of another class are usually designated as number nine dollies because of their resemblance to the figure nine. They are expensive tools to make, but for riveting under flanges and in places difficult to get a good tight rivet with the ordinary bars they soon pay for themselves.

Certain advantages are gained by using the holder-on instead of the solid dolly. The action of the machine meeting every blow of the hammer with an opposite force tends to make the rivets tighter; it is self-adjusting, the shortest length being about one foot. For long distances pieces of pipe of various lengths may be attached. The machine greatly lightens the buckler's work and speeds up heavy riveting, as the riveter, knowing the other head will be held positively, does not need to hit light blows on the start as he would if the buckler was holding a dolly bar. When using the solid bar the buckler must understand that to release the rivet not only may spoil it, but may be dangerous for him, as the riveter, not expecting the move, may not stop the hammer in time and the flying snap may hit him.

When it is necessary to drive rivets larger than the usual diameters through thick plates, a good job may be obtained with a medium-sized "gun," by bucking up with another gun. This operation is not fast enough to recommend it for regular work, but it will serve the purpose where such conditions are occasionally met.

Upon the judgment used in the selection of pneumatic hammers depends, to a great extent, the output of the riveting gangs. On freight work, of the total number of rivets driven,

about one per cent are $\frac{7}{8}$ in. or over in diameter, and about the same proportion are $\frac{1}{2}$ in. or smaller in diameter. Under usual conditions, therefore, these extremes may be disregarded when selecting the hammers. Any unusual sizes of rivets can be taken care of by the various expedients as suggested in this paper; but for passenger work, in which there are a great number of small rivets, small hammers should be used, as they use less air and leave fewer marks on the plates, being more easily controlled. The first requirement of the hammer is speed; then come lightness, compactness and simplicity of the parts, resulting in ease and cheapness of repairs. The hammer chosen should have a speed of about 800 blows per minute with a barrel or cylinder of medium length, and a piston of the dimensions shown in the accompanying drawing.

Tool manufacturers claim that the use of short pistons is the worst abuse a hammer can be subjected to, but practical experience in car work has proved that the machine is not injured from cutting, crumbling, or excessive wear if the piston is not made shorter than the length here shown. The steel used should be carefully chosen for the work, and in tempering should be drawn a shade softer than the rivet set, for if they are equally hard one will break. The sets, snaps or dies, as they are variously called, must be very carefully fitted to the hammer if a tapered piston is used, for if there is any play, the piston will hit one side and break.

Carelessness on the part of the riveter may explain some piston troubles. If he lays the hammer down in such a position that the piston rests against the snap when the latter is very hot, the temper of the piston may be drawn. A careful man will not lay his machine down without removing the piston and snap for this reason as well as for safety's sake. Usually the riveter makes far too many rivets before changing snaps, and the snap in consequence is very highly heated. It is taken out of the gun and left to cool, and when next used it is either very soft and spreads with the heat of the rivet, or it is brittle and breaks. Dies should be changed very frequently, say, every 35 or 40 rivets on $\frac{3}{4}$ -in. work, and more or less frequently according to the diameter, so that the snap will not reach the tempering point. Instead of allowing them to cool in the air, each riveter should have a bucket of water to cool his snaps in. Where the heat is not high enough for tempering, the action of the water

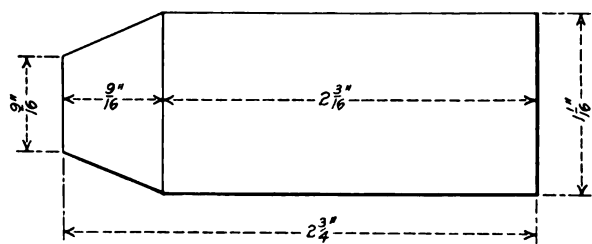

Taper Piston for Riveting Hammers

is cooling only, and the snap comes out with the original temper.

Hammer troubles are largely due to foreign matter carried by the air, and although the manufacturers will provide strainers, either in the hammer or the pipe, these are of such fine mesh that they clog up very quickly and there is no easy means of cleaning them, considerable time being required to take out, clean and replace one. The result is that the riveter puts it out of commission before the hammer has been in use very long. If the strainer could be made without these faults it would mean a great reduction in the repair bills. The life of a hammer may be greatly prolonged by following the manufacturer's instructions as to keeping it clean and well oiled.

INSPECTION

Inspection of riveting should be comprehensive enough to include all the details of the process. It should require hot and cold tests of every lot of steel received for rivet making. The cold stock should bend 180 deg. flat on itself, without fracture

on the outside. The head of a hot rivet should flatten until it is 2½ times the diameter of the shank without cracking at the edges. The best stock will stand heating almost white, driving through two thick, springy plates, and the removal of the assembling bolts as the rivet grows black. If a run of broken rivets and snapped off heads occurs, the trouble can generally be traced to the rivet material.

The general appearance of a riveter's work depends to a great extent on the holes he has to fill. If they are accurate and have not been reamed larger than is necessary to pass the hot rivets easily, the rivet heads should be well shaped and easily keep in alinement. On passenger work, where it is the practice to punch the holes ¼ in. small and ream to size, the riveters are able to produce good work more quickly.

Defective rivets can be detected by their color, the shape of the heads, or by tapping with a light hammer. An underheated or "green" rivet generally has a beautifully polished top, and is mushroom shape, not being closed down at the edges. It is easily knocked loose because the material in it was not hot enough to flow under the hammer and fill the hole. The overheated or burnt rivet head is pitted and has a cinder-like appearance. The nature of the steel has been changed and some of it wasted away entirely, so that the strength of the rivet is gone. This is usually the head held by the dolly, and it may happen that the heads are good, but are affected by the heat of the dolly itself. This may be remedied by drilling a small hole through the bottom of the cup, to meet another hole through the side of the die, thus forming a vent.

Rivet heads should be concentric with the shanks and close down against the work. Tightening up, recupping or caulking loose rivets should not be allowed, except for an occasional rivet not forming part of an important connection and not directly transmitting stresses. In cutting out rivets in places where it will be difficult to replace them, judgment should be used in deciding if the new rivet will be as good as the one already in, or if the plates will be parted and the adjoining rivets loosened up in driving it out.

REPAIRING WORN TAIL BRACES

BY H. C. SPICER

Gang Foreman, Atlantic Coast Line, Waycross, Ga.

The usual method of refitting worn tail braces is to send them to the blacksmith shop for filling in. Where this practice is followed it is necessary to finish the brace in the machine shop after the welding is completed. The method illustrated in the accompanying drawing is one which results in a saving of con-

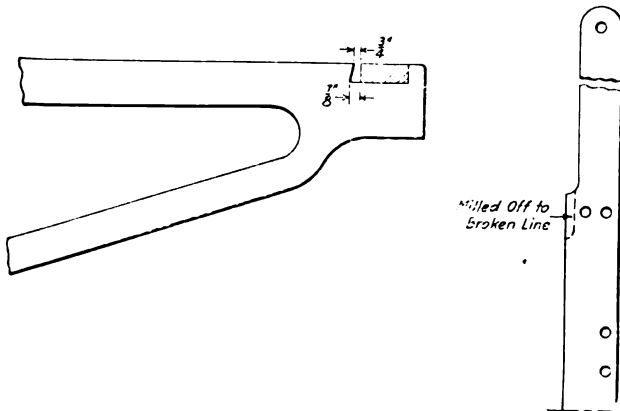

Method of Refitting Worn Tail Braces

siderable time and produces a more rigid foundation for the deck plate than the original construction. The worn bar is milled off to the broken line, as shown in the drawing, and its seats in the frame chipped to receive taper keys. The bar is

then replaced and the keys driven into position. When once repaired in this manner it should never be necessary to remove the deck in order to repair a worn tail brace, as the keys may be renewed in running repairs.

AIR PUMP RACK

BY JOHN H. NAGLE

Chief Draftsman, Buffalo, Rochester & Pittsburgh, DuBois, Pa.

When locomotives are undergoing repairs in the shop or roundhouse, the air pump is often removed and left on the floor until it can be replaced on the engine. The rack shown in the illustration was designed to provide a place on which to store air pumps after they have been overhauled and while waiting to be replaced on the locomotive. It has a capacity of four 8½-in. cross-compound pumps, or two 8½-in. cross-compound pumps and two 9½-in. pumps, placed on the rack in the manner shown in the illustration.

The rack is of simple construction and is built up of open-hearth steel plate and angles. The end and middle supports are formed of ⅝-in. plate, flanged at the center and secured to

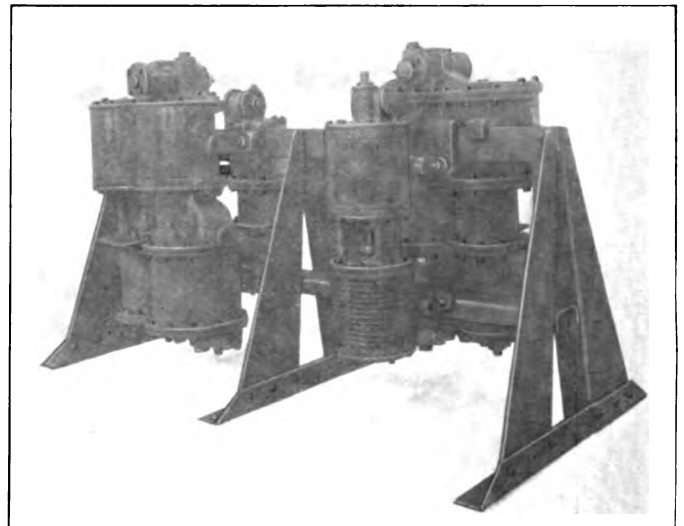

Rack for Storing Air Pumps

4-in. by 4-in. by ½-in. angles at the bottom. At a point about 16 in. above the floor a longitudinal member of ⅜-in. plate, flanged to form a channel section, is riveted to the flanges of the supports. The top rail is a 5-in. by 1¼-in. bar, from which the pumps are supported by means of wrought iron hooks. In placing a pump on the rack the hooks are removed and secured to the top bolting lugs by means of 1⅝-in. studs, which are included in their lower ends. Special hooks are provided for each size pump so that when hung upon the rack the bottom bolting flange rests against the channel member of the rack and the pump is supported in a vertical position. The space below the pump is clear, so that a truck may be run under the rack to receive the pump where crane service is not available.

KEEPING APPOINTMENTS.—A method of receiving visitors in vogue in a certain shop is worthy of mention. After the visitor has presented his card, stating the person he wishes to see, he is shown into a waiting room. His card is taken by the young man in the office and the time is stamped on the back with an automatic time-stamping machine. His card is then conveyed to the party with whom the appointment is desired. This time-stamping idea is valuable in that it has the tendency to cut down long waits in keeping appointments. It is further valuable if any question arises as to the length of time any party has been kept waiting.—*American Machinist.*

NEW DEVICES

SELF-CONTAINED GRINDING MACHINE

A line of self-contained, motor or single pulley driven grinding machines, in the construction of which special attention has been given to rigidity, has been developed by the Modern Tool Company, Erie, Pa. Aside from the attention given in the design of these machines to secure permanency of alinement there are several noteworthy features, including the method of operating the feed box, by which speeds and feeds may be changed while the machine is in motion. All levers and handles for the control of the machine are located in front within easy reach of the operator.

The machines are equipped with automatic cross feed which can be set for the reduction of any amount from .0005 in. to .005 in. at either or both ends of the table reverse. Feeding automatically on one end only is especially advantageous when grinding against a square shoulder. The feed is automatically thrown out when work is ground to size, and a positive stop is provided when feeding the wheel by hand in the production of duplicate work. An auxiliary feed for bringing the wheel automatically into the work when the table is not being traversed can be supplied. This is desirable when the work is short and can be covered by the full width of the wheel. The cross feed hand wheel is graduated to .0005 in. in plain view of the operator. The automatic cross feed is adjusted by the movement of

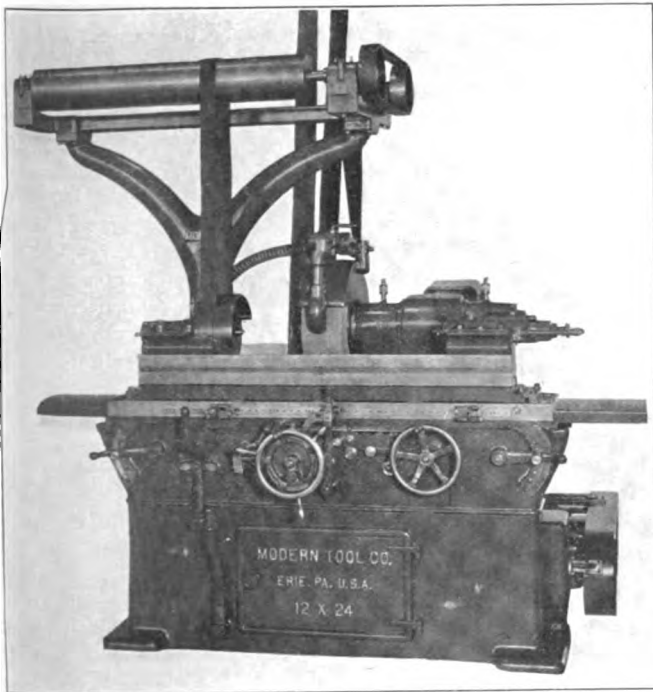

Self-Contained Single Pulley Universal Grinder

a lever to the point desired, as indicated on a graduated dial plate, and may be instantly changed to any feed while the machine is in operation.

The table is provided with power traverse, which is controlled by means of a lever placed to the left of the table hand wheel, and when power is applied to the table the hand wheel is automatically disengaged and remains stationary. When power is removed from the table the hand wheel is simultaneously engaged for traversing the table by hand. Another feature of note

is a variable tarrying device, by which the tarry at each end of the stroke can be regulated.

The base of the machine is of massive proportions and is crossbraced to insure rigidity. Flat and V guides are used as the sliding table, the swivel table and under the wheel stand. The base rests upon three points, preventing cross strain and insuring perfect alinement of the machine.

The machines are provided with a powerful drive, and have a large wheel spindle with ample bearings. The spindle is made of alloy steel, specially treated, ground and lapped to the re-

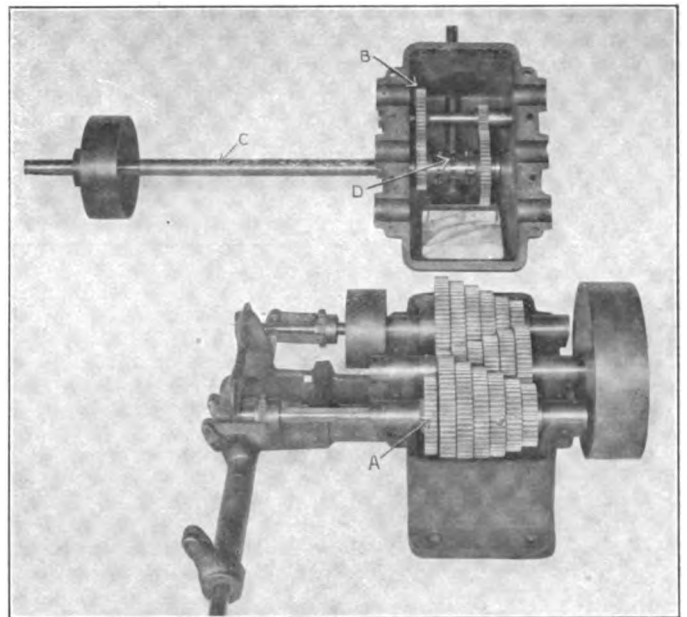

Arrangement of Gears in the Speed Box

quired size; it is $3\frac{1}{4}$ in. in diameter and runs in phosphor bronze bearings $8\frac{1}{4}$ in. long. These bearings are the same length on each side of the drive pulley and are provided with sight-feed oilers. The grinding wheel is driven by a 6-in. belt over large diameter pulleys. The wheel stand base is of large proportions and is bolted to the bed of the machine. The wheel stand, which has a broad spread, slides on V and flat ways and is held down by gravity. It is provided, however, with a safety gib to prevent lifting under abnormal conditions. The wheel center has a long, large bearing on the spindle, and will take any of the recognized standard grinding wheels.

The headstock is entirely belt driven, which gives an absolutely smooth movement to the work and eliminates any possible chance for chatter. It is fitted to the swivel table by means of V and flat ways and is held in position by a hooked clamp bolt. The headstock spindle is hardened and ground and runs in adjustable bronze bearings, lubricated by means of a sightfeed oiler. The tailstock is fitted to the swivel table in the same manner as the headstock. Its spindle is held in any position by means of a spring, or may be set positively against the work and locked. The work centers are directly over the table guides, a construction which eliminates the strain necessarily present where the work centers overhang the bearings. A wheel truing device is mounted on the tailstock and is adjustable to all diameters within the range of the machine, so that the wheel can be trued up without its being necessary to remove work from the centers.

All the speeds and feeds are derived from one gear box, which

forms an entirely separate unit and is located outside of the bed of the machine. All gears are in mesh at all times and are engaged with the shaft by a patent ball drive clutch, by means of which a change of speed or feed may be quickly and safely made while the machine is running. The speed box consists of three series of gears, which are journaled in the case and run at constant speed. The center gears are the drivers, being belt connected to the main driving shaft back of the machine. The gears at the rear control the table feeds and those in front the work speeds. Six table feeds and 12 work speeds are provided, the gears in the top of the case doubling the number of work speeds directly obtainable from the lower gears. Gear *A* meshes with gear *B* in the upper case, and the two gears on speed shaft *C* are loose except when one or the other is engaged by the positive clutch *D*, which is keyed to the shaft. Ample lubrication is supplied by the splash system, the lower part of the case being oil tight and filled with lubricants.

By referring to the illustration showing the details of the ball drive clutches it will be seen that the gears mounted on the front and back shafts in the lower part of the feed box are made with hardened ball pockets in the surface of the shaft bearing. Each set of gears is mounted on a sleeve rigidly secured to the driven shaft, the circular opening in the sleeve being placed over a splineway in the body of the shaft. These openings are contracted at their inner end and form pockets for the balls shown

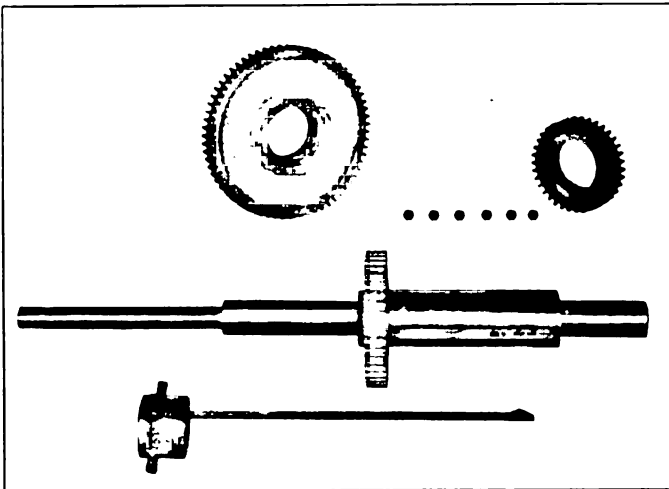

Work Speed Shaft Showing Details of the Speed Change Device

in the illustration. Any one of the gears on the shaft may be brought into action by means of the flat cam which slides in the splineway and brings the ball into engagement with the pocket in the hub of the gear, where it acts as a key between the gear and the shaft. While this device marks a departure from the usual methods of speed box control, it has been tested in service for several years, during which time its operation is claimed to have been entirely successful.

The work speeds range from 12 to 250 revolutions per minute, and the table feeds from 22 in. to 104 in. per minute, which cover every range within the capacity of the machines. The work speeds and table feeds being entirely independent of each other, it is possible to obtain a correct table feed for any given work speed.

These machines are built in sizes ranging from 24 in. to 60 in. between centers and will swing up to 16 in. in diameter. The regular wheel equipment is 18 in. in diameter by 2 in. face, but wheels as wide as 6 in. and 24 in. in diameter on the 12 in. machines, and 6 in. wide by 30 in. in diameter on the 16 in. machines, may be used as special requirements demand. The machines are arranged so that they may be driven either by a single belt at constant speed or by a motor connected directly to the end of the main drive shaft.

DIAPHRAGM-OPERATED TRIPLE VALVE

A system of air brake control, known as the automatic straight air system, including a triple valve and several auxiliary devices, in which the control is effected entirely by diaphragm-operated wing valves, has been developed by the California Valve & Air Brake Company, Los Angeles, Cal. The system is designed to operate in synchronism with the equipment now in general use, and in addition possesses a number of distinctive features which may be brought into service on trains made up entirely of automatic straight air equipment.

For use on passenger trains where the automatic straight air system is in service throughout the trains, the car equipment consists of the usual brake cylinder and auxiliary reservoir, the automatic straight air triple valve and a service reservoir, the function of which is to increase the train line volume. In freight service where the automatic straight air system must operate in connection with the systems now used, the car equipment consists of the usual form of brake cylinder and auxiliary reservoir, the automatic straight air triple, a quick release and service reservoir charging valve, the function of which is to cut out the graduated release feature of the triple valve, the service reservoir and a service reservoir retaining valve, the function of which is to prevent the waste of service reservoir air should the train line pressure be reduced below equalization, as in an emergency application of the brakes. This device is not essential to the operation of the system, its use being entirely to effect economy in the use of air.

AUTOMATIC STRAIGHT AIR TRIPLE VALVE

A sectional elevation of the triple valve is shown in the diagram of freight car equipment. The body of the triple is made in five sections, each joint being provided with bolting flanges between which is secured a diaphragm of annealed commercial copper. The diaphragms are secured at the center, between heads and follower plates, through which they are operatively connected to the valves of the triple. The functions of this triple valve are the graduated releasing of the brakes, under control of the engineer, and the recharging of the auxiliary reservoir; the graduated application of the brakes by the admission of train pipe air to the brake cylinders on a reduction in train pipe pressure; the admission of auxiliary reservoir air to the brake cylinders when brake pipe pressure is reduced below the point of equalization in a service application, and the quick emergency application of the brakes on a sudden reduction of train pipe pressure by venting both train pipe and auxiliary reservoir air to the brake cylinder. Application and release of the brakes, as well as the recharging of the auxiliary reservoir are effected entirely by diaphragms 3 and 24 and connecting parts. The release of auxiliary reservoir pressure to the brake cylinder in service emergency is performed by diaphragm 39, while in full emergency all parts of the valve are in operation. In the sectional elevation the parts of the triple are shown in lap position, all valves being closed with the exception of valve 51. When the engineer's brake valve is placed in full release position after a service emergency application of the brakes, train pipe pressure accumulates in chamber 2, under diaphragm 3, thereby forcing the diaphragm and head 8 upward, and carrying hollow rod 6, diaphragm 24, and valve cage 28 upward with it. When further movement of these parts is stopped by shoulder 26, diaphragm 3 continues to move, compressing spring 5 until the head strikes nut 7, thus opening valve 11 and admitting train pipe air to chamber 4 through grooves in the stem. Chamber 4 is at all times in communication with the auxiliary reservoir. The upward movement of diaphragm 24 and valve cage 28 lifts valve 35 from its seat. Chamber 25 is at all times in communication with chamber 25-A, above valve 51, by means of a passage which is not shown. The opening of valve 35 therefore releases brake cylinder pressure to the atmosphere through passages 86 and 85, to chamber 25-A,

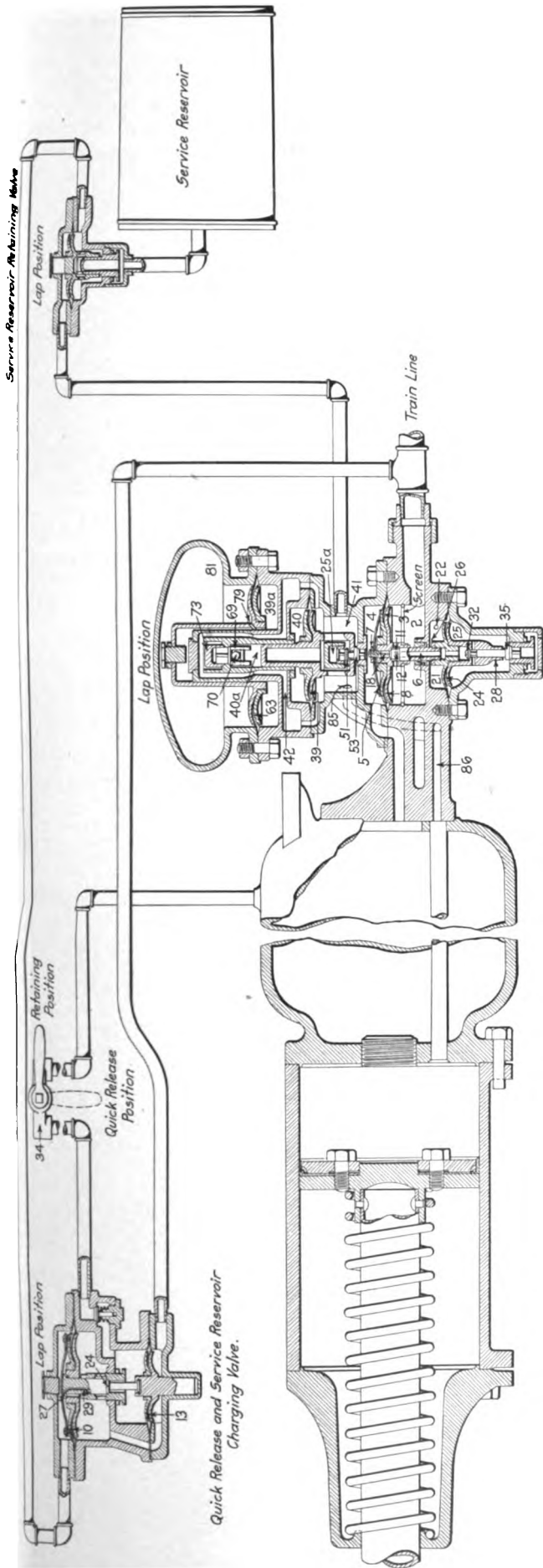

Automatic Straight Air Brake Equipment for Freight Cars

through the valve 51, and thence to the atmosphere from chamber 25 through holes in the cap at the lower end of the triple valve.

There is a passage for air between chambers 2, 39-A and 40, which is not shown in the engraving. Train pipe pressure thus acts at all times above diaphragm 39, which in release position firmly presses valve 53 to its seat. There is also a restricted opening 79, between chambers 39-A and 81, which maintains equal air pressure on both sides of diaphragm 63, except in emergency applications. There is no pressure at any time in chamber 21, above equalizing diaphragm 24, port 22 being provided to release to the atmosphere any air which may enter the chamber through leakage.

When the pressure in chamber 4 has reached an amount slightly less than full train pipe pressure, the tension of spring 5 causes the diaphragm 3 and head 8 to move downward, closing the auxiliary reservoir feed valve 11. A slight differential pressure acting upward against diaphragm 3 is thus maintained, which prevents undue sensitiveness to slight fluctuations in train pipe pressure.

When a reduction is made in train pipe pressure, the excessive auxiliary reservoir pressure in chamber 4 causes diaphragm 3 and head 8 to move downward, carrying with them rod 6, diaphragm 24 and valve cage 28. Within the valve cage is a graduating valve 32, the stem of which is attached to the stem of release valve 35. Further movements of the parts after valve 35 has seated causes the seat in the valve cage to move away from the graduating valve and opens communication between the train line and brake cylinders through the ports 12, the passage in the rod 6 and the ports shown in the valve cage. From chamber 25 the air enters the brake cylinder by the course already outlined. Train pipe air continues to flow to the cylinder until the accumulation of pressure under diaphragm 24 is slightly greater than the total reduction of pressure against the under side of diaphragm 3, when the parts will move upward, closing graduating valve 32. The relation of train line volume to brake cylinder volume and of the diaphragms 3 and 24 is such that this equalization takes place when the predetermined reduction in train pipe pressure has been effected. Should a brake cylinder leak cause a reduction in the pressure in chamber 25, the pressure in chamber 4 will cause a downward movement of the parts to application position until the brake cylinder pressure has been restored. Unequal piston travel does not affect the cylinder pressure, as the lapping of the graduating valve depends entirely upon the relative pressures in the train pipe and brake cylinder.

It will readily be seen that any increase in train pipe pressure will produce a differential pressure, acting upward against the two diaphragms, and that the resulting upward movement of the parts will open exhaust valve 35, thereby causing the release of air from chamber 25, and the brake cylinder to the atmosphere. The release of air continues until the reduction of pressure under diaphragm 24 causes the auxiliary reservoir pressure above diaphragm 3 to close the valve. Any definite increase in train pipe pressure will therefore cause a corresponding definite decrease in brake cylinder pressure. Graduated release is thus merely a reversal of the operations involved in a graduated application of the brakes.

The maximum service application is obtained at the point of equalization of the pressures in the brake cylinder and train line. This pressure is said to be the same as that obtained by other triples effecting equalization between the auxiliary reservoir and brake cylinder. A further reduction of train pipe pressure below the point of equalization reduces the pressure in chamber 40 below the brake cylinder pressure acting against the under side of diaphragm 39. The resulting upward movement of this diaphragm opens valve 53 and closes valve 51, thus admitting auxiliary reservoir air to the brake cylinder and producing an increase in brake cylinder pressure of about 20 per cent. This increase of braking power, which is known

as service emergency, is at all times available after a full service application of the brakes. A quick emergency application of the brakes is effected in the usual manner. A sudden reduction in train line pressure will cause the operation of diaphragms 3 and 24 in the manner previously described and will effect a reduction of the pressure in chamber 39-A at a rate faster than equalization can take place between this chamber and chamber 81, through the restricted passage 79. The resulting downward movement of diaphragm 63 opens valve 69 to which it is attached by rod 70. Chamber 40-A is at all times in communication with chamber 39-A, and train pipe air thus passes through valve 69, opening check valve 73 and thence passing directly into the brake cylinder. When equalization has been effected, check valve 73 drops to its seat, and diaphragm 39, moving upward, causes the release of auxiliary reservoir air to the cylinder. The closing of valve 51 prevents the excessive brake cylinder pressure from accumulating under diaphragm 24 and releasing the brake.

QUICK RELEASE AND SERVICE RESERVOIR CHARGING VALVE

The quick release and service reservoir charging valve is designed for use on freight cars. It performs two separate functions: a retardation of the rate of charging the service reservoir and the production of a quick release of the brakes, regardless of the rate at which the train pipe pressure accumulates. The use of this feature is optional, and it is controlled in the same manner as the retaining valve on present standard equipment. By opening the cock 34, a full release of the brakes will result from an increase in train pipe pressure. By placing the handle in the retaining position, which closes the cock, the graduated release feature of the triple is retained. The quick release is effected by venting auxiliary reservoir pressure to the train pipe through valve 24, thus destroying the differential action of diaphragm 3, in the triple valve, which controls the graduated release. Valve 24 is opened by an increase of 5 lb. in train pipe pressure acting upward against diaphragms 13 and 10, after any application of the brakes. A gradual equalization of the pressure on the two sides of diaphragm 10 is effected by feed groove 29. After the auxiliary reservoir has again recharged the valve will assume lap position, in which it is shown. A reduction in train pipe pressure will effect a downward movement of diaphragm 10, thus opening valve 27 and

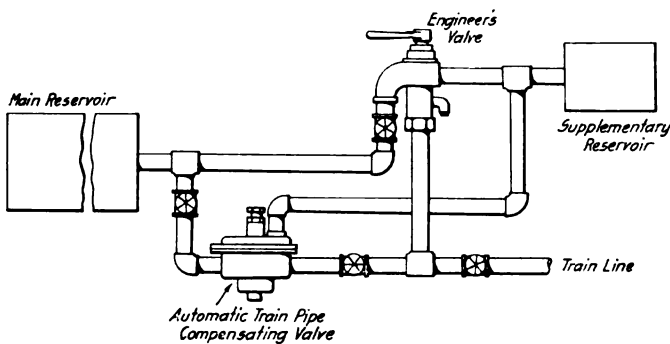

Diagram of Connections for the Automatic Train Pipe Compensating Valve

allowing a rapid flow of air from the service reservoir during an application of the brakes.

SERVICE RESERVOIR RETAINING VALVE

When a reduction in train pipe pressure is made beyond the point of equalization, the excess of brake cylinder pressure will cause the diaphragm in the service reservoir retaining valve to move downward and close the passage between the service reservoir and the train pipe, thus preventing the unnecessary loss of pressure from the service reservoir. On restoration of the train pipe pressure to the point of equalization, communication is restored.

AUTOMATIC TRAIN PIPE COMPENSATING VALVE

Where the automatic straight air equipment is operated in conjunction with other systems, no change is made in the equipment of the locomotive. Where solid trains of automatic straight air equipment are in service, however, an automatic train pipe compensating valve is added to the locomotive equipment. Referring to the diagram showing the connection and the sectional drawing of the device, it will be seen that it has three connections: one to chamber D of the engineer's brake valve, one to the main reservoir and one to the train pipe. The successful operation of this device depends upon the existence of an absolute seal between chamber D and the train pipe, which does not exist with the graduating piston in place. Since the compensating valve performs the functions of the graduating piston, the latter is removed and the lower body gasket of the brake valve replaced by a blind gasket.

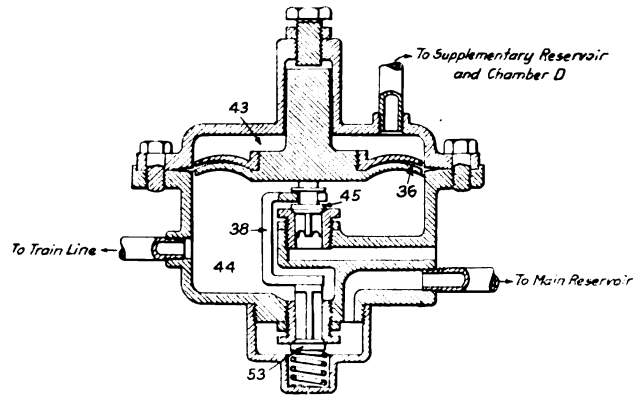

Sectional View of the Automatic Train Pipe Compensating Valve

When the pressure is reduced in chamber D the excess pressure in chamber 44 of the compensating valve causes an upward movement of diaphragm 36 and exhaust valve 45, thus releasing train line pressure to the atmosphere. When the brake valve handle is placed in lap position the pressure in chamber 44 will be reduced slightly below the pressure in chamber 43, and the exhaust valve will be closed by a downward movement of the diaphragm. While the brake valve remains in lap position, should any further reduction in train pipe pressure take place because of leakage, it will result in excess pressure above diaphragm 36, which will move downward carrying with it yoke 38. In its movement from the upper to the lower shoulder of the stem of valve 45, the yoke will open valve 53, thereby admitting main reservoir pressure to the train pipe. On the re-establishment of equalization in the two chambers, or of a slight excess in chamber 43, the diaphragm will move upward and the coil spring will close valve 53. In addition to the functions of the equalizing piston this device, therefore, maintains a constant train pipe pressure against leakage, while the engineer's brake valve is in lap position. With the compensating valve in service it is possible to maintain uniform and constant brake cylinder pressures with the automatic straight air triple, regardless of equality in piston travel, brake cylinder leakage or train pipe leakage.

These triples are claimed to render satisfactory service on both freight and passenger equipment, the only alteration required for passenger service being an increase in the size of the valve and passages to accommodate the greater volumes of air to be handled. Several triples are said to have been in continuous passenger service for 176 days on the Arizona Eastern, between Globe and Bowie, during which time they required no attention. On removal the diaphragms were found to have collected considerable sand, which had in no way impaired the operation of the triples. A number of these triples have been in freight service on the San Diego & South Eastern since May, 1913. It is said that during a year in sand and ballast service no attention was required for cleaning or repairs.

ADJUSTABLE SAW GUARD

A safety device of interest to users of wood working machinery is shown in the illustrations. It may be readily adjusted to the requirements of the work and when so desired may be swung out of the way. It is the invention of Hobart W. Curtis, foreman

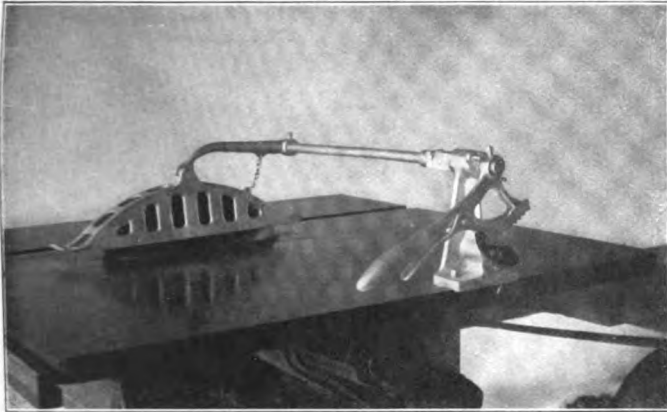

Fig. 1—Guard in Position Over the Saw

of the pattern department, Waterbury Farrel Foundry & Machine Company, Waterbury, Conn.

Fig. 1 shows the position of the guard while the saw is in operation. Fig. 2 shows the guard raised partially from the saw,

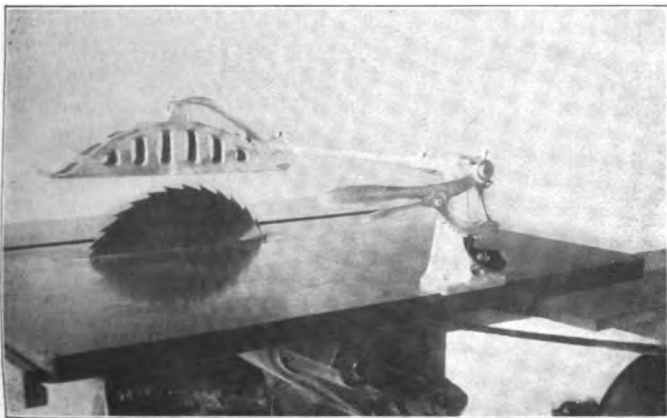

Fig. 2—Saw Guard Partially Raised

and Fig. 3 shows it raised to its full height and thrown over to one side, where it is kept when not in use. The guard is pivoted to an arm on a shaft which is supported by a bracket bolted to the saw table. The height of the guard is adjusted by means of a lever on the end of the shaft, and the check chain shown in the



Fig. 3—Saw Guard Swung Back from the Table

illustration is provided to prevent the guard from swinging against the saw. The shaft is provided with a joint near the bracket which permits the guard to be swung back when not in use. The guard is made from aluminum and the working parts from steel or iron.

SLIDE PLATE PLANER

A heavy planer for finishing slide plates used under switch points has recently been designed by the Cincinnati Planer Company, Cincinnati, Ohio. The slide plates are 18 in. long and about 6 in. wide and are planed 1/4 in. deep for a distance of about 6 in. from the end. The table is intended to receive two rows of plates and four tools are used, two in each head. This reduces the distance necessary to feed the heads from six inches to three inches, each of the two tools cutting half the distance. The full depth is taken in one cut at the rate of 40 ft. per minute.

In order to facilitate rapid checking and unloading, special transverse slots are cast in the top of the table, opening at the sides. The table is of the box type and provided with two inner guides between the V's. It is held down by adjustable gibs at the sides. The driving gears and table rack are of steel throughout.

The bed is of the four-wall design, having extra inner walls between the cross girths throughout its length. It is bored for

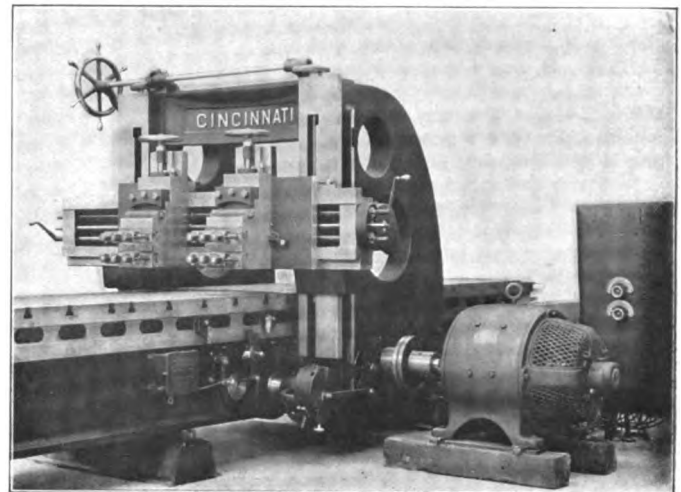

Planer for Finishing Switch Point Slide Plates

the shaft bearings, which are internally ground and fitted into place. The housings are wide and of heavy box form, carried down to the floor line and fastened to the sides of the bed by heavy tongues, bolts and dowels.

The rail and heads are the same as used on the frog and switch planer built by this company. The rail is secured to the housings by four clamps, two on the outer and two on the inner sides of the housing face. The heads are taper gibbed throughout and the dovetail for the down slide is cast solid with the saddles, thereby eliminating one extra joint. The clapper box is of steel and is provided with three heavy bolts and clamps, so arranged that two tools may be clamped in each head. A new style clamp is used for holding the clapper box at the top. Instead of a cored slot and two bolts, a clamp the full width of the slide is provided and three bolts are used.

The machine is driven by a reversible motor coupled directly to the driving shaft. This gives a large variation of cutting and return speeds, each independent of the other. All gears are thoroughly covered, to safeguard the operator against accidents.

The planer will take work up to 48 in. wide, 24 in. high and the table has a traverse 20 ft. long.

UNIVERSAL HOLLOW-HEXAGON TURRET LATHE

The latest product of the Warner & Swasey Company, Cleveland, Ohio, is an improved model of the universal hollow-hexagon turret lathe.

The most noticeable change is in the design of head. The former head has been superseded by one entirely new in type, and with gears running in oil. Not so apparent, but perhaps of greater importance, are the increased working range, the greatly increased power of the head, the corresponding increase in the rigidity and strength of the bed and the two tool carrying units, as well as the larger and more rigid tools. These changes have resulted in greatly increased capacity and efficiency. The greater capacity has been attained without noticeably increasing the size and operating dimensions of the machine; in fact, the new model is more compact than the former one. The automatic chuck of the No. 3-A machine now takes round stock up to $3\frac{1}{2}$ in., and the length turned has been increased to approximately 40 in. The swing over the cross slide carriage has been increased to $17\frac{1}{4}$ in., and the maximum swing of the machine to $21\frac{1}{2}$ in. The capacity of the No. 2-A machine has been correspondingly increased.

The new machine, it is claimed, has power and rigidity greatly in excess of requirements. The new geared head, with a 5-in. belt running on a 16-in. diameter pulley, is capable of delivering 14 horsepower, with a large overload factor. This power will be required only when machining heavy steel castings or forgings with several cuts being made simultaneously. The rigidity and strength of the bed, the two tool carrying units and the feeding mechanisms are well in proportion to the power delivered by the head to the work. The tools are redesigned in keeping with the increased capacity and more rigid construction. The splash system of continuous lubrication employed in the head, with the gears running in oil, insures a steady stream of lubricant. This reduces the frictional loss of power in the

The turret and carriage are power-operated simultaneously, with the turret and carriage feeds independent of each other. By this means two distinct operations can be made at the same time, as for example, boring with the turret while the carriage is facing or recessing and cutting off. Eleven tools may be placed in operation with one set-up. Through its various combinations, feeds ranging from 10 to 212 are produced. The machine has

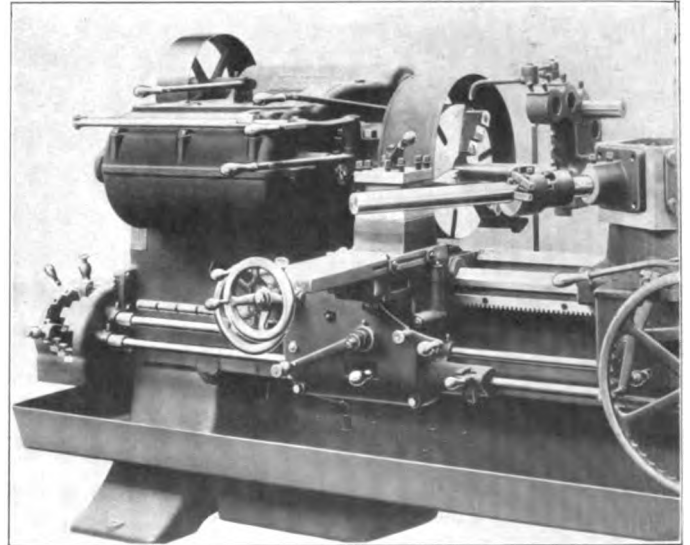

Head of Hollow-Hexagon Turret Lathe with Chucking Equipment

twelve spindle speeds, both forward and reverse, with ten feed changes in each direction for both carriage and turret. The feed changes are controlled by the feed box at the head end of the machine. The spindle speeds range in geometrical progression from 8 to 250.

As in the earlier type, the head is cast solid with the bed. It

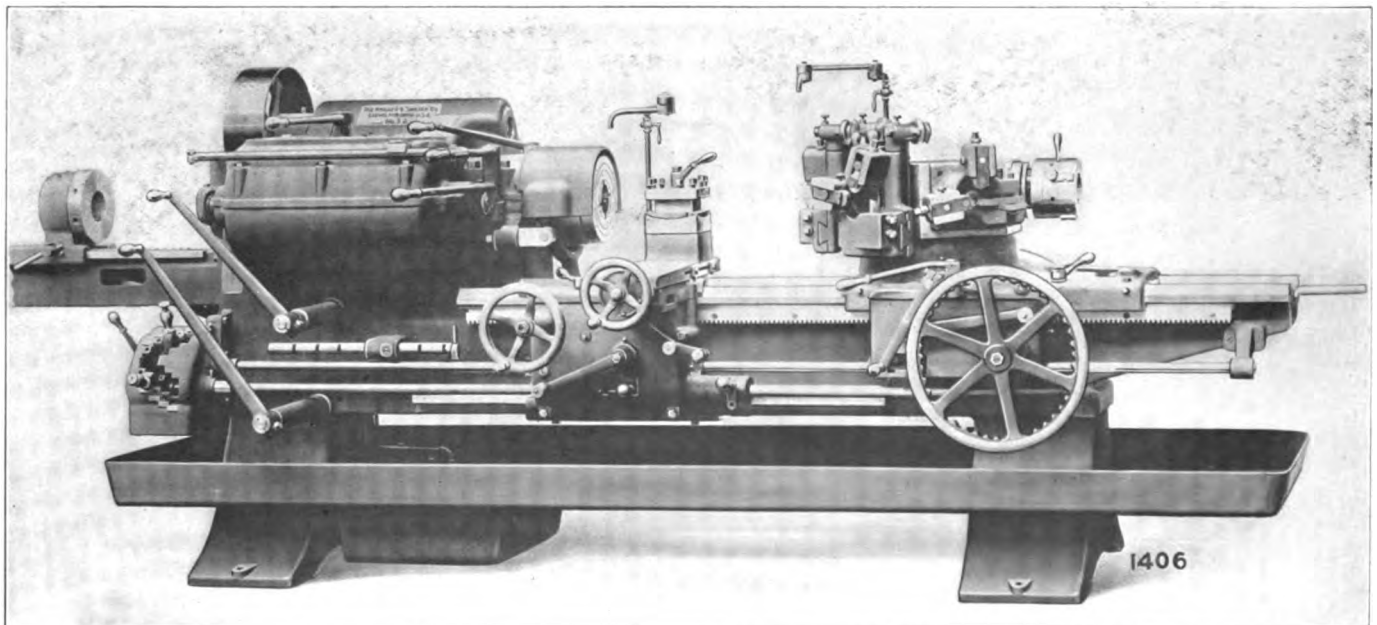

Hollow-Hexagon Turret Lathe Equipped for Handling Bar Stock

head, and effects a decided increase in the life of the machine.

The pan has been placed lower, to give increased space for chips and to assure easy accessibility to those parts of the machine directly over the pan. The legs have been redesigned to insure a solid support and freedom from vibration, and the turnstile operating the turret saddle has been superseded by a large hand wheel.

is the single-pulley type, and may be belted directly to the line shaft, or to a constant speed motor.

Taper-turning and screw-chasing attachments are furnished when desired. The taper attachment turns tapers up to $1\frac{1}{2}$ in. to the foot, in lengths of 15 in. The screw-chasing attachment cuts from 2 to 48 threads of any pitch. Each leader will cut three pitches that are multiples of 1, 2 and 4 of its own thread.

Every facility has been provided to make the machine easy of operation. The power rapid traverse of the turret saddle facilitates quick operation; the independent adjustable stops for both the turret saddle and the carriage greatly reduce the setting-up time; the hollow-hexagon turret permits tools to be bolted from the inside, assuring maximum use of each face of the turret, with full support for the tool in the direct line of thrust and torsional strains. The machine is equally adaptable to bar and chucking work.

PORTABLE LATHE

The American Tool Works Company, Cincinnati, Ohio, has recently placed on the market a portable 16-in. lathe, designed for railway shop use. It is the regular 16-in. American high-duty lathe with the eight-speed geared head for drive, and all standard equipment, such as the unlimited

ELECTRIC CRANE TROLLEY

The trolley shown in the photograph, in its general form, has been on the market for some time, but recently several improved details have been added and it now appears in a form embodying the most recent crane engineering practice. A primary consideration in the altered design has been safety, both in the way of strength and in the perfection of working parts. Durability of gears and other moving parts has been secured by enclosing and running them in an oil bath, thus protecting them from dust and grit. The construction is such that the covers of the gear cases must be in place before the gearing can be run, thus preventing carelessness in operating the trolley with gear covers removed.

Each train of back gears is rigidly mounted in a single frame, the bearings of which are bored in line, bronze lined and capped, through bolts being used throughout instead of studs. The hoist-

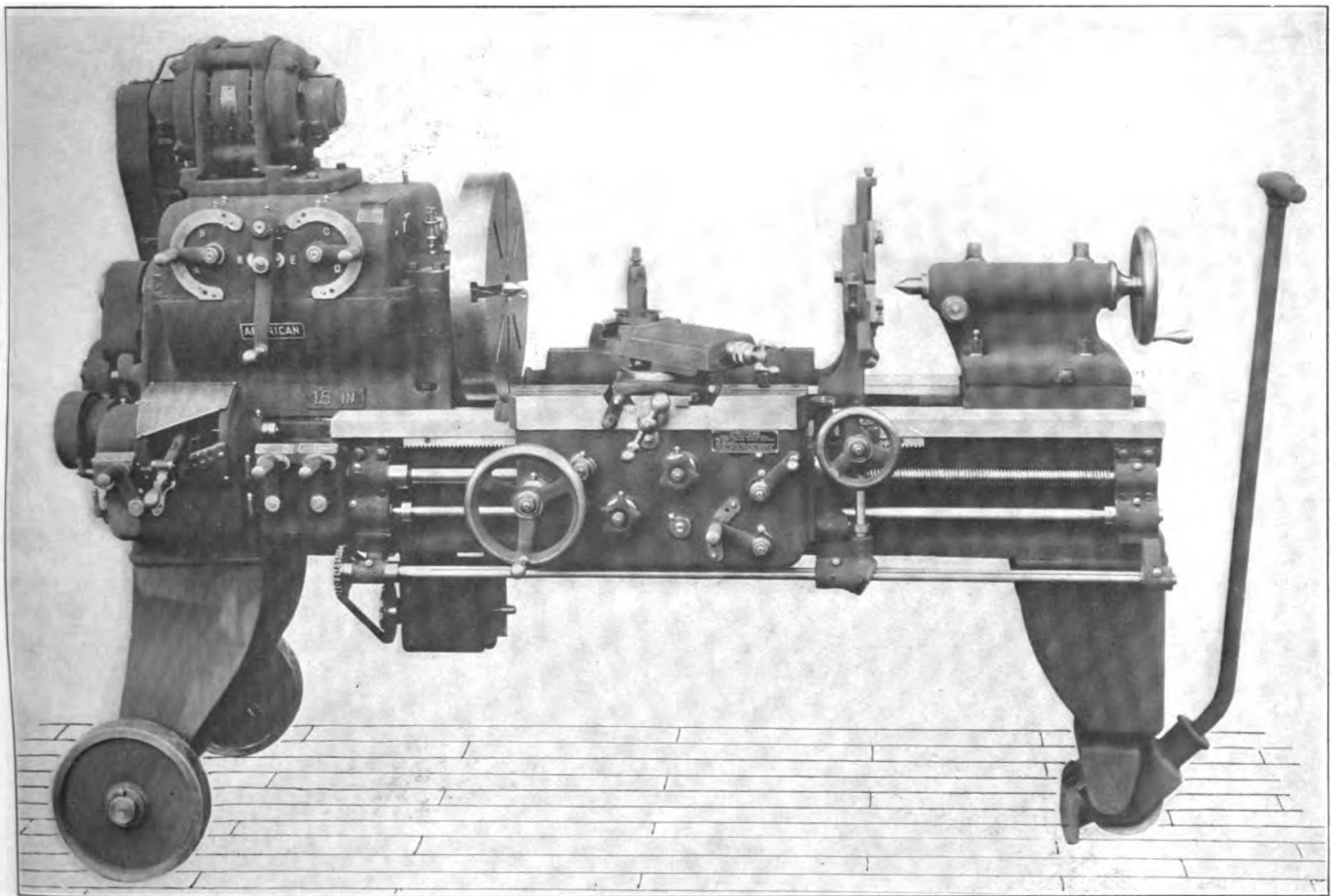

Portable Lathe for Railway Shops

quick-change gear mechanism, double plate, all-steel geared apron, chilled bed, heavy four-bolt tail stock and all-bronze bearings. The machine is mounted on three wheels and is provided with a long handle for hauling it about the shops. The three-point bearing on the floor provides a stable support for the lathe, even where the floor is uneven. The machine shown in the illustration was built for a large railway shop, and it is believed that it will prove of advantage where it is desirable and more economical to take the machine to the work rather than the work to the machine. The machine weighs approximately 3,200 lb.

IRON EXPORTS FROM SWEDEN.—Iron ore heads the list of Sweden's exports. During 1913, 6,440,000 tons were exported to foreign countries, chiefly England and Germany.—*Machinery.*

ing gear train between the armature and drum gear is in a single rigid casting which insures permanent alinement. The drum gear is enclosed in a case of the same general type that is used for the hoisting gearing. All gears bear in the frame and are capped on top, no overhung bearings being used. All gear covers are castings and the joints are placed so that they are perfectly tight, thus preventing the leakage and dripping of oil from the trolley to the floor of the plant. The covers may be easily lifted, but for inspection and lubrication large man-holes are provided in each cover. It has been found in practice that a set of gears in a trolley of the enclosed type running alongside a crane having a trolley with exposed or partially protected gears lasts more than three times as long as the gears in the old type of trolley and the operation is almost noiseless. The hoisting gear box is made an integral part of the main

trolley frame, thus securing permanency of alinement of all gears and their shafts.

A double system of electrical and mechanical brakes is used and the trolley is also equipped with an effective limit stop. Interchangeability has been insured by the use of standard gages and templates. The trolley is wired throughout in steel

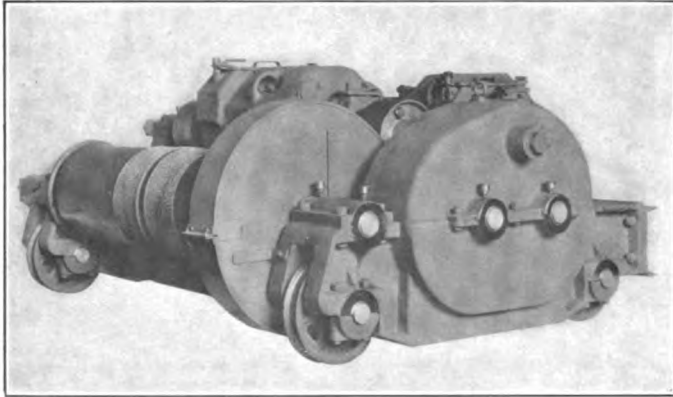

Electric Crane Trolley with Enclosed Gear Cases

conduits. It is built by the Northern Engineering Works, Detroit, Mich., and is made in capacities from 2 tons to 125 tons. For mill service the trolleys have axle bearings of either the vertical or horizontal cast M. C. B. type.

VACUUM PAINT SPRAYER

The accompanying illustration shows a paint sprayer, which is operated by means of a vacuum created in the delivery pipe. The paint is contained in the can under atmospheric pressure, and is drawn up into and through the nozzle by



Vacuum Paint Sprayer for Railroad Work

means of air pressure passing over a series of holes in the nozzle. The quantity of paint is regulated by the valve, as shown in the illustration, and the sprayer itself is controlled by a push valve which controls the flow of air. Air at the

ordinary shop pressure may be used to operate this machine, and its construction is of such a simple nature that it may be used by unskilled labor. The only precaution necessary in using this machine is to be sure that it is thoroughly cleaned, after being used, either by turpentine or by benzine, in order that the atomizer may not become clogged with the paint, which would otherwise harden while the machine is idle. This sprayer is sold by the Gustin-Bacon Manufacturing Company, Kansas City, Mo.

UNIVERSAL PIPE JOINT

A universal pipe joint that has been in successful use on Mallet engines on the Kansas City Southern is shown in the accompanying illustrations. In this specific instance the joint is used in the air brake train line on the locomotive,

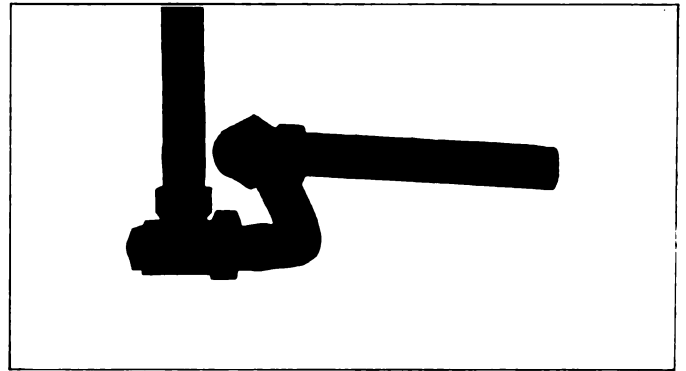

Universal Pipe Joint, Assembled

between the two driving units, to give the necessary flexibility. Its construction will be clearly understood from the photographs shown. The joints are ground to a fit, thereby requiring no packing. This joint will allow horizontal and vertical movements and is of special advantage between lo-

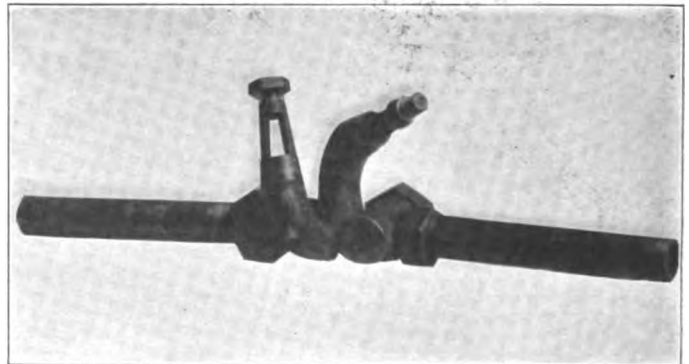

Parts of the Universal Pipe Joint

comotives and tenders. Its use can also readily be extended to the train pipe lines, and it will also find service in shops. This joint is sold by the Christy Universal Pipe Joint Company, 524 North Broadway, Pittsburg, Kan.

ALUMINUM ALLOY.—In their efforts to produce an aluminum alloy which would not be appreciably heavier than aluminum, but would possess a much greater tensile strength, German chemists have succeeded in making an alloy which has a tensile strength three times that of aluminum and which is composed of 1 per cent of tungsten and 9 per cent of cobalt or 0.8 per cent molybdenum and from 9 to 10 per cent of cobalt, the remainder being aluminum.—*Machinery*.

NEWS DEPARTMENT

The engineers who made preliminary surveys for a government railroad in Alaska have returned and have made an informal report to President Wilson.

On December 21 the machine shops of the Lake Erie & Western at Tipton, Ind., were destroyed by fire. Much machinery was also damaged. The estimated loss is \$20,000.

The Oklahoma railroads have issued a circular letter to the public giving arguments against a number of anti-railroad bills which have been introduced in the legislature, including the full crew law and the car limit law.

The large shops of the Baltimore & Ohio at Baltimore resumed work January 4 in every department, about 2,000 employees being put at work. The shops of the Big Four at Beech Grove, Ind., which had been closed for some time, resumed work January 1, with about 2,400 men.

The Pennsylvania Railroad reports no passenger killed in a train accident in 1914 on the entire system, east and west of Pittsburgh, 16,303 miles of road. The number carried was 188,411,876; passenger train miles, 67,389,381. The lines east of Pittsburgh in the past two years carried 311,675,794 passengers and not one of them was killed in an accident to a train.

A bill has been introduced in Congress by Mr. Goeke, of Ohio, H. R. No. 17,894, to amend the Boiler Inspection Act of February 17, 1911, so as to provide for the inspection by government inspectors of all parts of the locomotive and tender; and it has been passed by the House. A law of this nature was recommended by the Interstate Commerce Commission. In the Senate the bill was referred to the Committee on Interstate Commerce.

The Atchison, Topeka & Santa Fe has put in the field ten engineering parties to make a complete survey of one million acres of land which the road owns in the state of Arizona. This land is situated along the main line of the railroad, lying in alternate sections of 640 acres each. One purpose of the survey is that application for patenting the lands may be made. It is reported that steps will be taken for the agricultural development of parts of the land.

The board of directors of the American Society of Civil Engineers has adopted a resolution and sent it to President Wilson, declaring its opinion that "it would be unfortunate for the present Alaskan Railway Commission to be superseded, and that the interest of the public demands that the present commission be allowed to carry out the construction as well as the location of the proposed line." The commissioners are William C. Edes, Lieutenant Frederick Mears and Thomas Riggs, Jr.

The Illinois Central has given out a statement that during the two years ending January 1, 1915, it carried 26,271,000 passengers without a fatality to a passenger. In its Chicago suburban trains, which carry 40,000 passengers a day, the company says it has not killed a passenger for 53 years, or since the beginning of the suburban service, and it is also stated that no revenue passenger has been killed on the Illinois Central proper, exclusive of the Yazoo & Mississippi Valley, since March 6, 1910.

Finley Yard, the new gravity classification yard of the Southern Railway, near Birmingham, Ala., containing thirty miles of track, with a capacity of 2,000 cars, has just been placed in service. The buildings include a 25-stall roundhouse of reinforced concrete with a 90-foot electrically-operated turntable; a concrete coaling station with an overhead storage capacity of 1,000 tons, and water, sand and cinder handling facilities. Electric lights and a complete system of fire protection have been pro-

vided. The road will concentrate at Finley work which has been done at four different points scattered over a territory of ten miles.

At Altoona, Pa., petitions have been circulated asking the legislature of Pennsylvania to repeal the full crew law of that state. It is said that 90 per cent of the employees of the Pennsylvania Railroad in the shops at Altoona have signed the petition and have done so freely; but those who do not sign are making loud complaint. The language of the petition is the same as that in the letter of President Rea of the Pennsylvania road, in his recent appeal to the citizens of the state to abolish this oppressive law. At Harrisburg, Pa., the leaders of the brotherhood have announced that they are going to oppose the repeal of the full crew law.

The New York State Public Service Commission, First district, following its investigation of a collision on one of the elevated lines in Manhattan in December, and also of the recent subway accident which caused the death of one passenger, has ordered the Interborough Rapid Transit Company to take measures to have only steel cars in the subway from December 1 next. At present there are between 400 and 500 cars used in the subway which have wooden bodies with metal sheathing. In the discussion between the commission and the officers of the Interborough there has been a proposal to use these wooden cars on the elevated lines; but there are some obstacles to this plan and the matter seems to be still unsettled.

Of the recent order for rails placed with the Lackawanna Steel Company by the New York Central Lines 2,000 tons of open hearth rails are to be treated with .10 titanium. Although the New York Central Lines have had several small tonnages of titanium treated open hearth rails for which the Titanium Alloy Manufacturing Company, Niagara Falls, N. Y., has furnished the Ferro Carbon-Titanium free of charge for experimental purposes, this is the first bona fide order for titanium treated open hearth rails placed by the New York Central Lines and is the result of a long series of experiments which have been carried on under the general supervision of Dr. Dudley. The New York Central formerly used considerable titanium in the treatment of its Bessemer steel rails, the use of which has been practically abandoned during the last two or three years. It has now gone over to open hearth rails almost entirely.

THE NEW YORK CENTRAL RAILROAD

Under the reorganization of the consolidated New York Central Railroad Company, formerly the New York Central and Hudson River, the Lake Shore & Michigan Southern and the Chicago, Indiana & Southern, two grand divisions will be established, the eastern under W. J. Fripp, general manager, with headquarters at Albany; and the western under D. C. Moon, general manager, with headquarters at Cleveland. Under Mr. Moon will be two general superintendents, Albert S. Ingalls in charge of lines between Buffalo and Toledo, and Frank H. Wilson, in charge of lines between Toledo and Chicago. Under Mr. Fripp will be three general superintendents, T. W. Evans in charge of lines between Buffalo and Syracuse, and between Montreal and Clearfield, Pa.; E. J. Wright, in charge of lines between Syracuse and the electric zone at New York; and Miles Bronson, in charge of the electric division. Abraham T. Hardin will have general charge of operation, maintenance and construction as vice-president. Patrick E. Crowley will be in general charge of transportation on the consolidated lines between Chicago and New York as assistant vice-president. The road will

be divided into five operating districts: First, between New York and Syracuse; second, between Syracuse and Buffalo; third, between Buffalo and Toledo; and fourth, between Toledo and Chicago. The New York electrified zone constitutes a separate (fifth) district. Chicago is called the western terminus of the road, but there are really three western termini, the other two being Zearing, on the former Chicago, Indiana & Southern, 96 miles west of Chicago, and Danville, on the same road, 128 miles south of Chicago.

THE "CALL" OF THE MOVIES

At Sayre, Pa., an important division terminal of the Lehigh Valley, a stranger, whiling away a half hour in a moving picture house, was surprised, following a western photo drama, to see thrown on the screen an announcement like this:

"James Brown, Thomas Jones, William White and John Black boarded for 10 p. m."

This announcement apparently did not cause the least ripple of curiosity in the house, unless it was on the part of the visitor. The men named were members of a freight train crew. The division superintendent at Sayre has made an arrangement with the moving picture theater men so that freight crews can be called on their screens at any time. Thus the men can amuse themselves when they are in Sayre without fear of causing trouble for the call boys.

EFFECT OF PANAMA CANAL ON RAIL TRAFFIC

Railway and Marine News of Seattle, Wash., publishes an interview with a railroad man, stating that recently he saw on the side tracks at Huntington, Ore., 11 cars of Idaho wheat bound for Portland, to be sent from there by way of the Panama canal to the Atlantic seaboard. This, he said, was the first shipment of Idaho wheat ever carried by the Oregon Short Line to tidewater bound for another seaport. He also mentioned that dried fruits are now moving from the Pacific coast to Atlantic ports at a rate of 26 cents per 100 lb., and canned goods at 30 cents; and large shipments of salmon from Alaska, which have gone principally by rail to Chicago and the eastern seaboard, are now going by way of the canal. He also mentioned the case of a piano manufacturing concern in Chicago that has found out that it can ship in carload lots to New York and then by the canal to the Pacific coast cheaper than by rail from Chicago to the same point of destination; and that shipments of household furniture from Rockford, Ill., have moved to Pacific coast points by the same route.

The same publication reports an enormous demand for cold storage space on boats running through the canal, from the fruit and vegetable shippers along the Pacific coast. The steamer Ohioan of the American Hawaiian fleet, which sailed from San Francisco on December 23, was offered 8,000 tons of fruit and vegetables, fish and other products, which are best carried in cold storage rooms. The boat only had a capacity of 1,500 tons in its refrigerating rooms, and apples and fish had been offered at the Puget Sound ports which would fill this space. F. A. Hooper, district freight manager of the American Hawaiian Steamship Co., is quoted as saying that he has never seen anything to equal the demand for refrigerating space for the New

York trade, and that it has been necessary to allot the available space to the various districts to avoid complaints of discrimination.

BETTER INSPECTION OF FREIGHT TRAINS

Following the suggestion of one of its employees, C. F. Rudolph, telegraph operator at Stafford, N. Y., the Lehigh Valley has issued the following order:

"When freight trains are pulling out of sidings, or away from inspection points, or water stations where a stop has been made to take water, the engineer will move the train not to exceed six or eight miles an hour to permit a member of the crew to make a running inspection of the entire train.

"At such points, one or more members of the train crew must be at the head end of the train before it starts and inspect the train as it passes, watching closely for bent axles, broken flanges, brake rigging down, defective brake rigging, defective arch bars, defective drawheads, wheels sliding, brakes sticking, loose wheels, hand brakes applied, car doors loose, or any other defects that can be detected."

MEETINGS AND CONVENTIONS

Western Railway Club.—A few months ago the Western Railway Club appointed a "booster" committee for the purpose of devising means whereby a larger attendance of railway men in and about Chicago may be obtained at the meetings. From replies to circular letters sent out by this committee it was deemed advisable to hold the meetings in the afternoon instead of the evening. This will give members of the club living outside of Chicago an opportunity to attend the club without having to stay in Chicago all night. This practice was in vogue about 15 years ago, and it is hoped that its revival will prove satisfactory and that the members will avail themselves of the opportunity of attending the afternoon meetings.

The Engineering Foundation.—At a meeting held in the Engineering Societies building, New York, Wednesday evening, January 27, the Engineering Foundation was inaugurated, and it was announced that Ambrose Swasey, designer and builder of the Lick, Yerkes and United States Naval Observatory telescopes, and an engineer, scientist and astronomer of distinction, had given \$200,000 to promote engineering research.

Mr. Swasey is a member of the firm of Warner & Swasey, Cleveland, machine tool builders and manufacturers of telescopes, in which branch they are among the largest in the world. Mr. Swasey is 69 years old, a past president of the American Society of Mechanical Engineers and of the Cleveland Engineering Society, a member of the Institution of Mechanical Engineers of Great Britain and of the British Astronomical Society. He is a Fellow of the Royal Astronomical Society. In 1900 he received from the French government the decoration of the Legion of Honor for his work on astronomical instruments.

The administration of the fund will be conducted by the Engineering Foundation Board elected by the trustees of the United Engineering Society, and composed of nine members from the American Society of Civil Engineers, the American Society of Mechanical Engineers, the American Institute of

RAILROAD CLUB MEETINGS

Club	Next Meeting	Title of Paper	Author	Secretary	Address
Canadian	Feb. 9	Toronto Grade Separation.....	J. R. W. Ambrose...	James Powell....	St. Lambert, Que.
Central	Mar. 11	Rules of Interchange.....	Committee Report...	Harry D. Vought.	95 Liberty St., New York.
New England....	Feb. 9	Railroad Fuel Economy.....	M. C. M. Hatch....	Wm. Cade, Jr....	683 Atlantic Ave., Boston, Mass.
New York.....	Feb. 19	Train Despatching by Wireless.....	L. B. Foley.....	Harry D. Vought.	95 Liberty St., New York.
Pittsburgh.....	Feb. 26	Experiments on Truck Side Frames.....	Prof. L. E. Endsley..	J. B. Anderson...	207 Penn Station, Pittsburgh, Pa.
Richmond.....	Feb. 8	New York Terminals.....	H. S. Balliet.....	F. O. Robinson...	C. & O. Ry., Richmond, Va.
St. Louis.....	Feb. 12	Locomotive Superheaters.....	R. M. Ostermann...	B. W. Frauenthal.	Union Station, St. Louis, Mo.
South'n & S'w'rn.	Mar. 18			A. J. Merrill.....	Box 1205, Atlanta, Ga.
Western	Feb. 16	What Is a Locomotive?.....	Geo. S. Goodwin....	Jos. W. Taylor...	1112 Karpen Bldg., Chicago, Ill.

Mining Engineers, and the American Society of Electrical Engineers, with two members to be chosen at large.

American Society of Mechanical Engineers.—The Chicago Section of the American Society of Mechanical Engineers held a "railroad night" at the La Salle hotel, Chicago, on January 8, 1915, papers being presented on Locomotive Superheaters and Locomotive Stokers by R. M. Ostermann, Locomotive Superheater Company, and Clement F. Street, Locomotive Stoker Company, respectively. Mr. Ostermann gave an illustrated description of the locomotive superheater and quoted from tests showing how the steaming capacity of a locomotive boiler may be increased by the use of the superheater. As a rough average a coal saving of 25 per cent and a water saving of 35 per cent can be obtained from a superheater engine as compared with a saturated steam engine of the same class. He stated that there were 32,000 locomotives equipped with the top-header type superheater, of which there are nearly 12,000 in use on this continent.

Mr. Street showed the importance of the locomotive to the earnings of a railroad and how by the use of the stoker on large engines their capacity may be increased 10 per cent. He also briefly described the different types of stokers in general use on American railways, and stated that there were nearly 1,000 locomotive stokers in use today. These two papers were discussed by R. Quayle and H. T. Bentley of the Chicago & North Western.

Willard A. Smith of the Railway Review gave a talk on Railway Economics, in which he questioned the policy of some of the railways in adopting the modern heavy rolling stock before their traffic demanded such equipment. He stated that the general adoption of this policy has led to an increase in maintenance of equipment costs which has become a serious burden to the railways of this country. He attributed the increase in operating ratios mainly to this cause. As another reason for increased maintenance costs he mentioned the lack of proper shop facilities, stating that in many cases equipment was purchased by roads that did not have the proper facilities for maintaining it. He believed there is a more fruitful field in developing the efficiency of the locomotive than its size. He also advocated a bureau of railway engineering, which could be created by the government, private institutions or the railways themselves, for the purpose of studying scientifically and experimentally railway problems that are now being threshed out individually by the railways with necessarily an economic loss.

The following list gives names of secretaries, dates of next or regular meetings, and places of meeting of mechanical associations.

- AIR BRAKE ASSOCIATION.**—F. M. Nellis, 53 State St., Boston, Mass. Convention, May 5-7, 1915, Hotel Sherman, Chicago.
- AMERICAN RAILWAY MASTER MECHANICS' ASSOCIATION.**—J. W. Taylor, Karpen building, Chicago. Convention, June 9-11, 1915, Atlantic City, N. J.
- AMERICAN RAILWAY TOOL FOREMEN'S ASSOCIATION.**—Owen D. Kinsey, Illinois Central, Chicago. Convention, July 1915, Chicago.
- AMERICAN SOCIETY FOR TESTING MATERIALS.**—Prof. E. Marburg, University of Pennsylvania, Philadelphia, Pa.
- AMERICAN SOCIETY OF MECHANICAL ENGINEERS.**—Calvin W. Rice, 29 W. Thirty-ninth street, New York.
- CAR FOREMEN'S ASSOCIATION OF CHICAGO.**—Aaron Kline, 841 North Fifthth Court, Chicago; 2d Monday in month, except July and August, Lytton building, Chicago.
- CHIEF INTERCHANGE CAR INSPECTORS' AND CAR FOREMEN'S ASSOCIATION.**—S. Skidmore, 946 Richmond street, Cincinnati, Ohio.
- INTERNATIONAL RAILWAY FUEL ASSOCIATION.**—C. G. Hall, 922 McCormick building, Chicago. Convention, May 17-20, 1915, Chicago.
- INTERNATIONAL RAILWAY GENERAL FOREMEN'S ASSOCIATION.**—William Hall, 1126 W. Broadway, Winona, Minn. Convention, July 13-16, 1915, Hotel Sherman, Chicago.
- INTERNATIONAL RAILROAD MASTER BLACKSMITHS' ASSOCIATION.**—A. L. Woodworth, Lima, Ohio. Convention, August 17, 1915, Philadelphia, Pa.
- MASTER BOILER MAKERS' ASSOCIATION.**—Harry D. Vought, 95 Liberty street, New York. Convention, May 26-28, 1915, Chicago, Ill.
- MASTER CAR BUILDERS' ASSOCIATION.**—J. W. Taylor, Karpen building, Chicago. Convention, June 14-16, 1915, Atlantic City, N. J.
- MASTER CAR AND LOCOMOTIVE PAINTERS' ASSOC. OF U. S. AND CANADA.**—A. P. Dacie, B. & M., Reading, Mass. Convention, September, 14-17, 1915, Detroit, Mich.
- NIAGARA FRONTIER CAR MEN'S ASSOCIATION.**—E. Frankenberger, 623 Brisbane building, Buffalo, N. Y. Meetings monthly.
- RAILWAY STOREKEEPERS' ASSOCIATION.**—J. P. Murphy, Box C, Collinwood, Ohio. Convention, May 17-19, 1915, Hotel Sherman, Chicago.
- TRAVELING ENGINEERS' ASSOCIATION.**—W. O. Thompson, N. Y. C. & H. R., East Buffalo, N. Y. Convention, September 1915, Chicago, Ill.

PERSONALS

It is our desire to make these columns cover as completely as possible all the changes that take place in the mechanical departments of the railways of this country, and we shall greatly appreciate any assistance that our readers may give us in helping to bring this about.

GENERAL

J. K. BRASSILL, general master mechanic of the Northwestern Pacific at Tiburon, Cal., has been appointed superintendent of motive power and marine equipment of the Northwestern Pacific lines, with headquarters at Tiburon.

J. DUGUID has been appointed assistant mechanical superintendent of the Central Vermont at St. Albans, Vt.

D. R. MACBAIN, superintendent of motive power of the Lake Shore & Michigan Southern, which is now consolidated with the New York Central Railroad, has had his jurisdiction extended over the Illinois division of the New York Central, formerly the Chicago, Indiana & Southern. His office remains at Cleveland, Ohio.

FRANK W. TAYLOR, division master mechanic of the Illinois Central at Waterloo, Iowa, has been appointed superintendent of machinery of the International & Great Northern, with headquarters at Palestine, Tex., succeeding C. H. Seabrook, resigned.

MASTER MECHANICS AND ROAD FOREMEN OF ENGINES

F. J. BARRY, general inspector of air brakes, steam heat and lighting of the New York, Ontario & Western, with office at Middletown, N. Y., has been appointed master mechanic, with office at Mayfield Yard, Pa., succeeding W. H. Kinney, resigned, and his former position has been discontinued.

D. E. BARTON has been appointed acting master mechanic of the Atchison, Topeka & Santa Fe, with headquarters at Argentine, Kan., succeeding E. E. Machovec.

NORMAN BELL has been appointed master mechanic of the Minnesota and Iowa divisions of the Illinois Central, with headquarters at Waterloo, Iowa, succeeding Frank W. Taylor, resigned to go to another company. Mr. Bell was born at Elkhart, Ind., July 30, 1884, and was educated in the Elkhart public schools, later serving as a machinist apprentice with the National Manufacturing Company of Elkhart. He entered the service of the Illinois Central as a machinist March 1, 1904, and was appointed erecting foreman at Waterloo, Ia., July 9, 1910. He was appointed general foreman at that point August 1, 1910, and served in that capacity until January 1, 1915, when he was appointed master mechanic of the Minnesota and Iowa divisions, as above noted.

J. P. DOLAN has been appointed master mechanic of the Appalachian Northern, with office at Port St. Joe, Fla., succeeding R. A. Billingham.

H. F. HOWSER, road foreman of engines of the Baltimore & Ohio at Brunswick, Md., has been appointed road foreman of engines and assistant trainmaster of the Shenandoah district, at Harrisonburg, Va.

F. T. HUSTON has been appointed assistant master mechanic of the Pennsylvania Lines West of Pittsburgh at Fort Wayne, Ind., succeeding E. E. Griest, promoted. Mr. Huston graduated in mechanical engineering from Purdue University in 1904 and entered the service of the Pennsylvania Lines as an apprentice, later serving as machinist. In August, 1907, he was appointed motive power inspector, and was engaged in special work and in inspecting new locomotives to January 1, 1912, when he was appointed assistant master mechanic of the Allegheny shops. On January 1, 1914, he was appointed assistant master mechanic

at Crestline, Ohio, which position he held at the time of his appointment as assistant master mechanic at Fort Wayne, Ind., January 1, 1915, as above noted.

W. MALTHANER has been appointed master mechanic of the Baltimore & Ohio, at Newark, Ohio, succeeding O. J. Kelley, assigned to other duties.

J. L. SCHRIEVE has been appointed assistant road foreman of engines of the New Castle division of the Baltimore & Ohio, at Chicago Junction, Ohio.

E. E. GRIEST, assistant master mechanic of the Pennsylvania Lines West of Pittsburgh at Fort Wayne, Ind., has been appointed master mechanic at that place, succeeding B. Fitzpatrick, deceased. Mr. Griest was born at Zanesville, Ohio November 28, 1882, and entered railway service as a clerk in the auditor's office of the C. & M. at Cambridge, Ohio, in 1899. This office was transferred to Pittsburgh in 1900 and he then entered the division freight agent's office at Cambridge as a clerk and messenger. Early in 1900 he entered the Columbus, Ohio, shops of the Pittsburgh, Cincinnati, Chicago & St. Louis as an apprentice machinist, remaining there in that capacity and as machinist until November 1, 1904. During the last six months of his apprenticeship Mr. Griest was assigned to special work under the master mechanic, being in charge of moving the machinery, taking out the steam engines and installing motors in connection with the changing of the shop from steam to electric drive. On the completion of this work he was assigned to re-arranging the piece work prices and work in connection with the introduction of high speed steel and improving shop methods. On November 1, 1904, he entered the school of mechanical engineering at Purdue University, graduating in 1907. He spent one summer vacation in mining work in Alaska and from July 1 to November 1, 1907, was a designer in the engineering department of the Crucible Steel Company of America at Pittsburgh. From November 1, 1907, to January 31, 1908, he was employed as a foreman in the Erie Railroad shops at Hornell, N. Y., and on February 1, 1908, became assistant machine foreman of the Pennsylvania Lines West at Fort Wayne, Ind. On March 15, 1909, he was promoted to assistant master mechanic of the Fort Wayne shop, the position he held at the time of his appointment as master mechanic at that point on January 1, 1915, as noted above.



E. E. Griest

CAR DEPARTMENT

JOHN A. FICKEL has been appointed car foreman of the Grand Trunk at Fort Erie, Ont., succeeding D. C. Messeroll.

JOHN M. HAWKINS has been appointed assistant general car foreman of the Rock Island Lines at Shawnee, Okla., succeeding G. N. Dorr.

A. KIPP, general car inspector of the New York, Ontario & Western, will have charge of matters relative to steam heat and lighting, owing to the appointment of F. J. Barry as master

mechanic, and B. P. Flory, superintendent of motive power, will assume direct charge of air brake matters.

R. LILLY, formerly car foreman of the Canadian Pacific at Three Rivers, Que., has been appointed night car foreman at Place Viger, Montreal, succeeding E. Minshell.

C. H. McCLELLAN, formerly car foreman of the Canadian Pacific at Ottawa, Ont., has been appointed car foreman at Place Viger, Montreal, succeeding G. H. Turner, transferred.

D. C. MESSEROLL, formerly car foreman of the Grand Trunk at Fort Erie, Ont., has been appointed general traveling car inspector of the Ontario Lines, and districts 8, 9 and 10, Eastern Lines, succeeding T. Rogers.

W. MILLS has been appointed general car foreman of the Grand Trunk Pacific, succeeding E. Hacking.

C. A. MURDOCK, car inspector of the Canadian Pacific at Outremont, Que., has been appointed car foreman at Three Rivers, Que., succeeding R. Lilly, transferred.

F. REID has been appointed car foreman of the Canadian Pacific at Weyburn, Sask., succeeding C. H. Zerbach.

G. H. TURNER, formerly car foreman of the Canadian Pacific at Place Viger, Montreal, has been appointed assistant car foreman at Outremont, Que., succeeding R. D. C. Weldon.

R. D. C. WELDON, formerly assistant car foreman of the Canadian Pacific at Outremont, Que., has been appointed car foreman at Sortin Yard, Montreal, succeeding M. I. Miller.

SHOP AND ENGINE HOUSE

S. GORDON has been appointed foreman of locomotive store orders of the Canadian Pacific at the Angus shops, Montreal, succeeding F. G. Goddard.

E. HACKING, formerly general car foreman of the Grand Trunk Pacific, has been appointed general foreman of the Transcona, Man., car shops of that road, succeeding L. E. Burnsville.

F. W. WARREN, formerly locomotive foreman of the Grand Trunk at Coteau, Que., has been appointed locomotive foreman at Southwark, Montreal terminals, succeeding D. Ross.

PURCHASING AND STOREKEEPING

C. L. BURGESS has been appointed storekeeper of the Intercolonial Railway, at Gibson, N. B., succeeding F. Dunbar.

J. M. COLES has been appointed storekeeper of the Canadian Pacific at Swift Current, Sask., temporarily, succeeding G. O. Jackson, who has enlisted for military service.

T. W. COOKE has been appointed storekeeper and timekeeper of the Canadian Pacific, at Minnedosa, Man., succeeding E. Ashworth.

J. B. A. DESALAUX, formerly storekeeper of the Canadian Pacific, at Wilkie, Sask., has been appointed storekeeper at Assiniboia, Sask., and his former position has been abolished.

E. G. GOODWIN has been appointed fuel agent of the Southern Railway, the Virginia & Southwestern and the Northern Alabama, with headquarters at Knoxville, Tenn., and subsidiary offices at Birmingham, Ala., and Princeton, Ind.

A. P. HUNTER has been appointed storekeeper of the Canadian Pacific at Coquitlam, B. C., succeeding C. Bradley.

G. R. INGERSOLL, purchasing agent of the Lake Shore & Michigan Southern, which is now consolidated with the New York Central Railroad, has had his jurisdiction extended over the Illinois division of the New York Central, formerly the Chicago, Indiana & Southern, with office at Cleveland, Ohio.

JOSEPH KELLER has been appointed to the new position of general fuel inspector of the Lehigh Valley, with office at South

Bethlehem, Pa. Mr. Keller was previously a member of the board of examiners for enginemen on the Lehigh Valley at South Bethlehem.

J. P. MURPHY, general storekeeper of the Lake Shore & Michigan Southern, which is now consolidated with the New York Central Railroad, has had his jurisdiction extended over the Illinois division of the New York Central, formerly the Chicago, Indiana & Southern, with office at Cleveland, Ohio.

P. J. MURPHY, formerly storekeeper of the Canadian Pacific, at Broadview, Man., has been appointed storekeeper at Crownsnest, B. C., succeeding E. J. Burke.

H. A. SEWELL has been appointed storekeeper of the Canadian Pacific, at Broadview, Sask., succeeding P. J. Murphy.

OBITUARY

THOMAS L. CHAPMAN, formerly superintendent of motive power of the Chesapeake & Ohio, died on December 30, at the home of his son in Caldwell, N. J., at the age of 71.

EDMUND P. HENDERSON, formerly a master mechanic of the Southern Pacific, died at San Antonio, Tex., on January 4, aged 75 years.

JOHN B. LAURIE, purchasing agent and general storekeeper of the Central Vermont, with headquarters at St. Albans, Vt., died on January 16, at his home in that city after an illness of many months. Mr. Laurie was born on February 22, 1862, at Sarnia, Ont., and began railway work with the Grand Trunk. He served as storekeeper on the Grand Trunk at London, Ontario, until September, 1899, when he left that road to enter the service of the Central Vermont, and since that time until he was compelled on account of poor health to give up active work he had been purchasing agent and general storekeeper of the Central Vermont, with headquarters at St.



J. B. Laurie

Albans, Vt. Mr. Laurie is survived by one sister, who is also a resident of St. Albans.

CHARLES A. THOMPSON, formerly superintendent of motive power and equipment of the Central Railroad of New Jersey, died on January 4 at Jamaica, N. Y., at the age of 81.

BOILERS OF LOCOMOTIVES WHICH ARE HELD OUT OF SERVICE.—It frequently happens in locomotive service that 15 or 20 locomotives are set aside for a time and the general practice is to drain the boilers. We have found in one or two cases that where that was done and sufficient time allowed to elapse, when we come to use them again they were pretty badly pitted and rusted. On the other hand, where these boilers were left full of water, there was no deterioration. In the case of a locomotive that only went into service occasionally, in the course of a couple of years we found that boiler in bad shape. When we built a new boiler for the same service and adopted the practice of leaving it full of water, that seemed to cure the trouble.—*D. J. Redding, before the Railway Club of Pittsburgh.*

SUPPLY TRADE NOTES

L. H. Mesker is now connected with the sales department of Kearney & Trecker Company, Milwaukee, Wis., and after February 1 will represent that company in Ohio.

Samuel Higgins, formerly general manager of the New York, New Haven & Hartford, has been elected president of the Standard Heat & Ventilation Company, New York and Chicago.

The Henry Giessel Company, Chicago, Ill., has appointed Frank N. Grigg, 1201 Virginia Railway & Power building, Richmond, Va., as southeastern sales agent, representing the company in all territory south of the Ohio river and east of the Mississippi river.

C. B. Yardley, Jr., has been appointed representative of the Wm. C. Robinson & Son Company, Baltimore, Md., manufacturers of high grade lubricating oils and greases. Mr. Yardley will make his headquarters at the New York office, 12 Coenties Slip, and his territory will include the eastern railroads.

A fire on the night of January 18 totally destroyed the insulated wire department of the John A. Roebling's Sons Company, Trenton, N. J., at an estimated loss of \$1,000,000. No part of the wire mills or wire rope works was damaged, and the work performed by the plant destroyed will be taken care of in other shops.

David A. Wright, who for several years past has been connected with the Yale & Towne Manufacturing Company, New York, as district manager in the west, has opened an office for himself as manufacturers' agent at 140 South Dearborn street, Chicago, Ill. He will specialize on labor saving and pneumatic machinery, cranes, etc.

H. H. Seabrook, formerly district manager of the Westinghouse Electric & Manufacturing Company in Baltimore, has been appointed district manager of the company at Philadelphia, succeeding J. J. Gibson, who has become manager of the tool and supply department at East Pittsburgh. Owing to a consolidation of territories the Philadelphia offices will hereafter embrace that previously covered by the Philadelphia and Baltimore offices.

Announcement is made that on January 1 the John Seaton Foundry Company and the Locomotive Finished Material Company, Atchison, Kan., were consolidated, and that they will hereafter continue the business of both companies under the name of the Locomotive Finished Material Company. The directors of the consolidated companies are as follows: John C. Seaton, H. E. Muchnic, Clive Hastings, W. S. Ferguson and G. L. Seaton.

Arrangements have been completed for an extensive display of the hydraulic machinery manufactured by The Hydraulic Press Manufacturing Company, Mount Gilead, Ohio, at the Panama-Pacific International Exposition at San Francisco, Cal., in 1915. The exhibit is being installed in block 11 in the Palace of Machinery, and will occupy a space 27 ft. wide by 67 ft. long. It will be in charge of the company's Pacific coast representative, The Berger & Carter Company, 1045 Seventeenth street, San Francisco, Cal.

Joseph T. Ryerson & Son, Chicago, are offering a prize of \$100 in gold for the best trade name for the line of tool steel which the company is selling. The company has been selling a complete line of tool steel for many years, but has had an outside manufacturing connection for the steel, and in consequence adopted the name used by the manufacturer. It has since been found necessary either to manufacture or control the manufacture of the steel, which the company has now been doing for some time. In addition to the \$100 first prize, those who send in the 100 next best names will be given a copy of a loose-leaf leather reference book of steel and engineering data, and for the next best 200 names bound volumes of the same book will be given.

CATALOGS

WHISTLES.—A leaflet issued by the Walter A. Zelnicker Supply Company, St. Louis, Mo., is devoted to the "Old Noisy" gong whistle. This whistle is made in sizes from 2 in. to 12 in. and is intended for use on factories and shops.

STEAM-HYDRAULIC PRESSES.—Bulletin L from the Mesta Machine Company, Pittsburgh, Pa., contains eight pages describing steam-hydraulic presses for shearing, bending, forging, flanging and punching. Illustrations of several of the machines are given.

ELECTRIC METERS.—Bulletin No. 40, issued in December, 1914, by the Sangamo Electric Company, Springfield, Ill., contains 32 pages and describes and illustrates clearly different forms of electric meters. Details of the construction are given and several pages are devoted to diagrams showing the connections.

STEEL WAREHOUSE TRUCKS.—A folder issued by the Edwards Manufacturing Company, Cincinnati, Ohio, is devoted to the steel trucks made by this company. These are two-wheel trucks intended for use in warehouses, freight sheds, railway shops, etc. They are built principally from structural steel shapes.

EYE-PROTECTING GLASSES.—Safety Service Bulletin No. 4 and other literature from T. A. Willson & Co., Inc., Reading, Pa., describes and illustrates the line of safety glasses manufactured by this company. These glasses are made in a variety of forms, some of which are especially suited for the different classes of shop work.

FORGING MACHINES.—The National Friction-Slip Flywheel is the subject of National forging machine talk No. 6. This is a two-page folder and contains a good half-tone illustration of the National heavy pattern forging machine equipped with a friction-slip flywheel, as well as a sectional view of the flywheel and considerable data concerning it.

AIR COMPRESSORS.—The Chicago Pneumatic Tool Company, Chicago, has issued bulletin No. 34-K, dealing with this company's class N-SO and N-SG fuel oil and gas driven air compressors and their application to the unit system of air power plants. The bulletin contains 24 pages and describes and illustrates these compressors in considerable detail.

CURTAIN FIXTURES.—Bulletin No. 182, issued by the Dayton Manufacturing Company, Dayton, Ohio, describes and illustrates the Dayton curtain for railway car windows. This curtain is fitted with friction shoes bearing in grooves which hold the curtain in position and retaining strips prevent accidental displacement. A guide for convenience in ordering is given on the last page.

FACTS ABOUT FUEL OIL.—This is the title of a four-page leaflet issued by the Production Engineering Company, 1716 Spring Garden street, Philadelphia, Pa. This leaflet is devoted mainly to the advantages claimed for the Peco burner. Another four-page leaflet has also been issued by this company containing an article on Fuel Oil and Its Application, by David Townsend, president of the company.

OIL TESTING SET.—The General Electric Company has just issued bulletin No. 49,901, describing an oil testing set by means of which the dielectric strength of oil can be easily determined. The proper use of this set insures the successful operation of high-tension oil insulated apparatus. The set consists of a 30,000-volt testing transformer with an induction regulator for voltage control and an oil spark gap, all of which are assembled as a unit.

METAL PROTECTION.—"Lohmannized" is the subject of a 15-page booklet, illustrated by half-tone engravings, which has just been issued by the Lohnmann Company, 50 Church street, New York. This process is explained as "a non-corrodible coat-

ing, which is integrally attached to an article of iron or steel, the coating and the base being welded." Microphotographs are given, showing the results of the process and the results of tests are also included.

PORTABLE MACHINE TOOLS.—The 1915 portable machine tool catalog issued by the Pedrick Tool & Machine Company, Philadelphia, Pa., contains 62 pages, and includes a great deal of information as to this company's various portable machines. These tools include cylinder boring bars, motor driving attachments for boring bars, crank pin turning machines, portable milling machines, pipe bending machines, etc. The catalog is completely illustrated.

HEAT TREATING FURNACES.—Bulletin No. 7, issued by the Quigley Furnace & Foundry Company, Springfield, Mass., is devoted to underfired, accurate temperature, heat-treating furnaces, using gas or oil fuel and manufactured by this company. These furnaces are intended for heating small material for annealing, hardening, tempering, carbonizing, forging, etc., where uniform and controllable temperature is required. The bulletin is illustrated.

AIR COMPRESSORS.—Bulletin No. 34-S, dated November, 1914, and issued by the Chicago Pneumatic Tool Company, Fisher building, Chicago, Ill., is devoted to small power-driven air compressors. The compressors are made in several different forms, both air and water cooled and either gasoline engine or motor driven. The bulletin describes and illustrates the various types, as well as the sheet steel suction and discharge valves which are used on all sizes above 3 in. by 3½ in.

STEAM RAILWAY ELECTRIFICATION.—Special publication No. 1,552 of the Westinghouse Electric Manufacturing Company, East Pittsburgh, Pa., is devoted to a brief description of the equipment supplied by this company for several recent steam railway electrifications. Other sections of the bulletin deal with developments in subway, elevated, interurban and street railway equipment. Photographs taken in a number of cities are included, showing the various types of cars in service.

LIGHTNING ARRESTERS.—Bulletin No. 45,602 has just been issued by the General Electric Company, Schenectady, N. Y., and deals with the subject of the protection of series lighting circuits by lightning arresters. The arresters described in the bulletin are of two types, the horn type and the aluminum type. The former is designed for the protection of series transformers and rectifiers against lightning discharge and similar trouble, and the latter particularly for the protection of cable circuits running from series arc rectifiers.

ELECTRICAL SUPPLIES.—The Western Electric Company, 463 West street, New York, has issued its 1915 Electrical Supply Year Book. This book contains 1,216 pages, and, besides listing and cataloging the company's various electrical equipment, contains a great deal of useful information in the form of tables and formulas. The book contains an alphabetical index, and will enable the trade to determine at a glance the approximate cost of any one of the articles listed. One of the features of the book is an advertising bulletin embracing examples of advertising and selling helps which the company furnishes to its agents in connection with the sale of goods.

RAILWAY LINE MATERIAL.—The General Electric Company, Schenectady, N. Y., has recently issued bulletin No. 44,004, which forms an ordering catalog descriptive of railway line material for direct suspension. This publication covers practically everything in line material for this method of suspension, save poles and wire. The parts are illustrated and each illustration is accompanied by the proper catalog numbers. The prices are not included. The bulletin contains also miscellaneous data relative to construction, overhead material per mile, general data on the use of solid copper wire and copper cable, dimensions of grooved trolley wire sections, etc.

Railway Age Gazette

MECHANICAL EDITION
INCLUDING THE
AMERICAN ENGINEER

PUBLISHED ON THE FIRST THURSDAY OF EVERY MONTH BY THE
SIMMONS-BOARDMAN PUBLISHING COMPANY,
WOOLWORTH BUILDING, NEW YORK, N. Y.

CHICAGO: Transportation Bldg. CLEVELAND: Citizens' Bldg.
LONDON: Queen Anne's Chambers, Westminster.

EDWARD A. SIMMONS, *President* L. B. SHERMAN, *Vice-President*
HENRY LEE, *Secretary*

The address of the company is the address of the officers.

ROY V. WRIGHT, *Editor*

R. E. THAYER, *Associate Editor* A. C. LOUDON, *Associate Editor*
C. B. PECK, *Associate Editor*

Subscriptions, including the eight daily editions of the *Railway Age Gazette* published in June in connection with the annual conventions of the Master Car Builders' and American Railway Master Mechanics' Associations, payable in advance and postage free:

United States, Canada and Mexico.....	\$2.00 a year
Foreign Countries (excepting daily editions)....	3.00 a year
Single Copy	20 cents

Entered at the Post Office at New York, N. Y., as mail matter of the second class.

WE GUARANTEE, that of this issue 5,000 copies were printed; that of these 5,000 copies 4,333 were mailed to regular paid subscribers, 200 were provided for counter and news companies' sales, 209 were mailed to advertisers, exchanges and correspondents, and 258 were provided for samples and office use; that the total copies printed this year to date were 14,300, an average of 4,767 copies a month.

The RAILWAY AGE GAZETTE, MECHANICAL EDITION and all other Simmons-Boardman publications are members of the Audit Bureau of Circulations.

VOLUME 89 MARCH, 1915 NUMBER 3

CONTENTS

EDITORIALS:	
Help Keep the Premises Clean.....	105
Alterations in Locomotives to Increase Capacity.....	105
Design of Reciprocating and Revolving Parts.....	106
Billing Repairs on Foreign Cars.....	106
High Power per Unit of Weight.....	106
Economical Maintenance of Equipment.....	107
The Value of the Locomotive.....	107
New Books.....	107
COMMUNICATIONS:	
Practice Versus Theory in Design.....	108
The Bonus System.....	108
GENERAL:	
Reciprocating and Revolving Parts.....	109
Uncoupling Lever for Switch Engines.....	115
Portuguese Express Locomotive.....	116
Economic Value of a Locomotive.....	118
CAR DEPARTMENT:	
The Standard Box Car—A Negative Viewpoint.....	121
Piece Work and Its Advantages.....	122
Steel Baggage and Mail Cars.....	123
Experiments to Determine the Stresses in Truck Side Frames.....	127
Economies in Freight Car Repairs.....	129
SHOP PRACTICE:	
Clips for Securing Date Tags to Steam Gages and Safety Valves.....	131
Points for Apprentices to Ponder.....	132
Chuck for Finishing Boiler Check Bodies.....	133
Shop Notes from the Soo Line.....	133
Engine House Organization.....	135
Water Gage Cocks.....	136
Shop Efficiency.....	137
Packing Iron for Journal Boxes.....	137
Special Beading Tool and Boiler Patch Bolt.....	137
Reboring Air Pump Cylinders.....	138
Machine for Boring Driving Boxes.....	138
The Best Practices in Engine House Work.....	139
Some Factors in Locomotive Maintenance.....	140
Index Head for Holding Rod Brasses.....	140
NEW DEVICES:	
Roller Journal Bearing.....	141
Hydraulic Pipe Bender.....	142
Vertical Band Saw for Metal Cutting.....	142
Automatic Nut Tapping Machine.....	143
Car Wheel Grinder.....	143
Forged Brake Beam Fulcrum.....	144
Adjustable Fire Door Pedal.....	144
Pneumatic Plate Flanging Clamp.....	145
Safety Hose Clamp.....	145
Triplex Hydraulic Pump.....	146
Sand Blast Helmet.....	146
Heavy Duty Universal Milling Machine.....	146
Pneumatic Light Forging Hammer.....	147
Magnet for Removing Metal from the Flesh.....	148
NEWS DEPARTMENT:	
Notes.....	149
Meetings and Conventions.....	150
Personals.....	150
Supply Trade Notes.....	152
Catalogs.....	154

Help Keep the Premises Clean

"With a pig and a goat your plant would compare favorably with some back yards I've heard about," is a remark made by a superintendent to the man in charge of one of the company's shops. He might have said much more as to the advantages to be derived from neat shops and premises, but he believed that the comparison was enough, and in this case it proved so. There are other railway shops in this country to which this same remark might apply. To them we desire to convey the message that neat, clean shops will do much to increase output, inspire careful workmanship, keep the employees contented and advertise the road in the right way. At the Burnside shops of the Illinois Central the officers make it a special point to keep the shops and surroundings orderly and as neat as the conditions will allow. Barrels made of scrapped corrugated roofing are placed at various points throughout the plant; they are painted white and kept that way. An inscription "Help Keep the Premises Clean" is neatly lettered on the covers. These white barrels contrast so vividly with the black cinder grounds that it is impossible to forget the purpose for which they are intended. The entire plant maintains a Sunday appearance day in and day out. The men like it and the shop officers believe that they are fully repaid for their trouble. It costs but little to do this and the advantages are many; you will be better satisfied with your work and the work of your men will better satisfy you if this policy is followed.

Alterations in Locomotives to Increase Capacity

The Kansas City Southern has recently completed some tests which were conducted with a view to modernizing a class of consolidation type locomotives. As originally built these engines had a tractive effort of 44,900 lb. and a weight on drivers of 182,600 lb., 22 in. by 30 in. cylinders, 55 in. driving wheels, a boiler pressure of 200 lb. and a grate area of 33.5 sq. ft. Alterations were made to two of them, one being fitted with a wide firebox providing a grate area of 62.5 sq. ft., while the other was fitted with a superheater, a brick arch and a design of piston valve chest which is applied directly to the slide valve seat and avoids the necessity of applying new cylinders. The cost to convert the engine which was equipped with a wide firebox, was \$4,850, while the cost for the other engine was \$2,775, the difference being about 43 per cent in favor of the latter locomotive. In comparative fuel tests the locomotive with the narrow firebox and a superheater used 24 per cent less coal per 100 ton-miles, 33 per cent less water per 100 ton-miles and developed an average running speed 15 per cent higher than the locomotive with the wide firebox. On a tonnage test the percentages in favor of the superheater locomotive were, in ton-miles, 15 per cent increase, running speed 11 per cent increase, fuel consumption 16 per cent decrease and water consumption 29 per cent decrease.

These figures are of more than ordinary interest as showing what can be done, by the expenditure of a comparatively small amount of money, in the way of increasing the capacity of many locomotives that have been or are now being pushed aside. In this case the factor of adhesion was such that an increase in the size of the cylinders would hardly be justified and it is doubtful whether the strength of the frames would permit such an increase. But there are plenty of other cases where different expedients should be justified in order to obtain another five or ten years' service on tonnage trains from existing locomotives. There have been quite a number of locomotives built within recent years with factors of adhesion lower than what was formerly considered good practice, and if the locomotive which it is desired to convert has a factor of 4.5 or over it is quite probable that an increase in the size of the cylinders could be safely made, provided the frames were strong enough to stand this increase. However, an increase of 2,000 or 3,000 lb. in maximum

tractive effort might well justify the replacing of the frames as well as the cylinders and as it is unlikely that such a conversion would be considered without the application of a superheater there would be, beside the increase in maximum tractive effort, a decrease in fuel and water consumption and a decided increase in sustained capacity. Moreover, the additional weight resulting from the superheater and allied changes would help in preventing the factor of adhesion from reaching a point which might be considered too low.

Any conversion of this nature will, of course, have to be justified by the results afterward obtainable and the changes just outlined would unquestionably run into a considerable amount of money. But there must be many cases where such modernizing methods would be justified provided the money for making the changes can be obtained. Under present day railroad conditions the question, "What will it cost?" comes with increasing emphasis and if the results obtained in the case of the Kansas City Southern locomotives are considered in relation to the cost of making the conversion, they will undoubtedly make a strong appeal to higher railway officers.

Design of Reciprocating and Revolving Parts

At all times a serious problem, the design of reciprocating and revolving parts for steam locomotives has greatly increased in difficulty with the advent of the high piston loads which result from the use of cylinders of the large diameters now common in locomotive practice. The real seriousness of this problem is probably best brought home by consideration of the effect of the pressure on the rail. When, with the high axle loads now in use, a variation between the maximum and the minimum weight on the rail, under any driving wheel, of 100 per cent of the static weight on that wheel may, and probably often does, result from the effect of the counterbalance, it can be readily seen that stringent measures are justifiable in reducing the weight of the parts of the locomotive which necessitate this counterbalance. In the article on "Reciprocating and Revolving Parts," which is published in another part of this issue, it is stated that the practical problem of balancing is not so much how to balance as how to reduce the total weight of the reciprocating parts to a minimum. There are a number of locomotives now in service, built during the past two or three years, which stand out very clearly as regards the design of these parts when compared with the average practice, and there seems no reason why such good results could not be more generally obtained. Indeed, it is plainly indicated by Mr. Campbell in this series of articles that they can be. The series is divided into three parts, Part 1 dealing with American design, Part 2 with British design and Part 3 with the use of alloy and heat treated steels. The author is already known to many of our readers and will be remembered as the writer of the article on "Locomotive Connecting Rods" published on page 175 of the *American Engineer* for April, 1913. This article was most favorably received, and is being very generally used by designers, and it is hoped that the present series will prove even more valuable as an aid to improved locomotive design.

Billing Repairs on Foreign Cars

Rather strong insinuations have sometimes been made concerning the honesty of some roads in regard to their bills for foreign car repairs. The paper read by H. H. Harvey, general car foreman of the Chicago, Burlington & Quincy, at the February meeting of the Car Foremen's Association of Chicago, in which he advocated the appointment of inspectors by the M. C. B. Association for inspecting foreign car repairs, we believe states the case correctly. Mr. Harvey said:

Without question, all roads do at times make improper charges, but in most cases, these are simply errors and not made with deliberate intent to defraud. However, it is quite possible that some few car owners deliberately charge for repairs not made, possibly not with the consent of the higher

officers, but through the zealotry of some of the minor officers, who are endeavoring to make a record for low cost of maintenance. These few, if there be such, are the ones who are to blame for the charge of dishonesty in repair bills, under the stigma of which all must suffer, the innocent as well as the guilty.

We believe that errors are the greatest causes for the improper charges and, further, that the errors are caused by the lack of a proper knowledge of the M. C. B. rules. Last month it was pointed out in these columns that ignorance of the rules was the cause of a large amount of unnecessary correspondence. It would seem, therefore, that much of the trouble now common in the handling of repairs to foreign cars could be eliminated if the men were made to learn the M. C. B. rules thoroughly and to use them intelligently. Some roads appoint inspectors whose duty it is to visit the various repair points of the road and check up the work done in repairing cars with the bills made out for these repairs. In the discussion of Mr. Harvey's paper it was stated that this procedure had resulted in satisfactory results and many cases were found where the foremen were cheating themselves. These inspectors, reporting direct to the superintendent of motive power, bring to light the weak spots in the car department, whether they be caused by ignorance of the rules or by over-zealous foremen endeavoring to make a showing. If this practice were generally adopted it is probable that the complaints for incorrect charges would be reduced materially and both the home road and foreign roads would be materially benefited.

High Power Per Unit of Weight

The development of over 2,000 indicated horsepower by a balanced compound passenger locomotive having a total weight of 165,300 lb. is a performance rarely, if ever, equalled in American practice. Such results are reported to have been realized in service from a recently built ten-wheel express passenger locomotive on the Portuguese State Railways, a description of which appears elsewhere in this issue. The conditions under which this power was developed are not known, and it is impossible to say whether it represents sustained performance or the power developed during a short period only. Two balanced compound Atlantic type locomotives, the cylinders of which compare very closely in size with those of the Portuguese locomotive, were tested on the St. Louis testing plant, the maximum indicated horsepower of each being between 1,600 and 1,700. The boilers of both of these engines were larger than that of the Portuguese locomotive, one having a total heating surface of 3,407 sq. ft. and the other a total heating surface of 3,237 sq. ft.

Atchison, Topeka & Santa Fe engine No. 535, with a total weight of 201,500 lb., a total heating surface of 3,237 sq. ft. and a grate area of 48.4 sq. ft., was shown by the test to be capable of maintaining a maximum indicated horsepower of 1,605 at 54 per cent cut-off with a steam consumption of 20.8 lb. per indicated horsepower hour. The Cole balanced compound, New York Central No. 3,000, with cylinders 15½ in. and 26 in. in diameter by 26 in. stroke, weighing 200,000 lb. and having a heating surface of 3,407 sq. ft. with a grate area of 49.9 sq. ft., was shown by the tests to be capable of developing a horsepower of 1,670 at 52½ per cent cut-off with a steam consumption of 23.2 lb. per horsepower hour. Comparing the Portuguese locomotive with these engines the possibilities for such a performance on its part are not evident. If this engine is capable of developing over 2,000 indicated horsepower, it must have an unusually low water rate for a saturated steam engine as, assuming a maximum evaporation of between 37,000 lb. and 38,000 lb., which would be higher than is usually obtained in American practice from the same heating surface and grate area, the maximum horsepower of the Portuguese engine must have been obtained at a water rate of about 17 lb. per indicated horsepower hour.

Economical Maintenance of Equipment

C. A. Seley stated at the January meeting of the Western Railway Club that the biggest question before the railroads at the present time is the proper and economical maintenance of equipment. This question, at all times a live issue with the mechanical department of American railways, is especially so at present. Each new design of equipment, with new machines for doing the repair work and with fluctuations in prices of material, alters the maintenance problem in some respect, and this problem is one that is worthy of study by the ablest men in the field.

Maintenance should first be considered when designing the equipment, and whenever possible, parts that are liable to need repairs or replacement should be so located and incorporated in the structure that they may easily be repaired or renewed. This necessitates the designers' familiarizing themselves with the repairmen's problems. From these men a great many details can be learned which, if carefully considered in designing, will show marked economies in the cost of repairs. The repairmen, on their part, should, from their experience, anticipate the making of repairs with special devices or jigs where the number of cases warrants such devices, in order that the work may be done as quickly as possible and with a minimum labor cost. They will also do well to study the supply field for machines and apparatus, the purchase of which may be of material assistance to them in their work and which with the saving in the cost of repairs will be a profitable investment for their companies.

An economical feature in which all railway mechanical men are directly interested is the reclaiming of scrap material. Several railroads are giving this subject attention; some have installed extensive plants for this specific purpose, while others are giving it a very close study with a view of enlarging the plants they now have in operation. There are numerous other avenues for maintenance economies. Every man should put his shoulder to the wheel. Give the companies the best ideas you have.

The Value of the Locomotive

If the ideas in G. S. Goodwin's paper on the "Value of a Locomotive," presented at the February meeting of the Western Railway Club, and abstracted elsewhere in this issue, are thoroughly studied, followed and elaborated on by the railway mechanical men of this country, we will find mechanical departments operating on a scientific basis that heretofore has not been thought possible. Mr. Goodwin established a basis—the net earning power of a locomotive—from which should be determined the method of handling power. He has shown that the average net earning power of all locomotives in this country is \$44 a day. He has also shown that for individual engines this value will vary greatly according to the conditions under which they operate. It will be found that locomotives of low net earning capacity will require a different method of handling from those of high net earning capacity if true economy is to result.

Some motive power men strongly advocate the regular assignment of engines; others are advocates of pooling the service. The former claim more mileage, fewer failures, more reliable service, etc., while the latter's chief argument is that fewer engines are required and that there is always an engine ready for the transportation department. But we only hear the mechanical man's point of view, and he has only based his arguments on the results he sees, not on an analytical economic study. We have yet to hear from a purely economic point of view as to which is the better system. A scientific economic study of this question would be of great advantage to all the railways and would undoubtedly lead to many changes in the methods of handling motive power. Mr. Goodwin has outlined a basis on which to work.

Strong exceptions were taken to 53.96 per cent of a freight

locomotive's day being charged to the mechanical department, especially as the road from which these figures were obtained operates under the pooling system. Under the circumstances it is almost impossible to question the figures, as the system by which they were obtained had been in effect for some time. With this statement the question naturally arises, "What must be an engine's dead time in the regular crewed system?"

NEW BOOKS

Installing Efficiency Methods. By C. E. Knoepfel. 258 pages, 6¼ in. by 10 in. Illustrated. Bound in cloth. Published by the Engineering Magazine, 140 Nassau street, New York. Price \$3.

There have been so many books published within recent years dealing with the principles of scientific management that when a new one is brought out it arouses but little interest. In this book, however, Mr. Knoepfel endeavors to avoid the matter of a mere declaration of principles and tells what the methods are that are known to increase the efficiency of a manufacturing plant and also how they are put into use. The introduction to the book states that the purpose has been to give wholly frank and thoroughly practical working instructions and explanations, covering the entirety of efficiency practice as tested and proved in many important and successful undertakings carried out by the author; it would seem that this purpose has been effectively carried out. As originally prepared, the material in the book appeared in a series of articles published in the Engineering Magazine during 1914, but this is expanded and changed to a considerable extent in this volume. The chapter on the efficiency clearing house has been considerably enlarged and chapters added on costs and on auxiliary devices for the planning department. A considerable number of charts, diagrams and illustrations have also been added.

Heat-Treatment of Steel. Compiled by the Editors of Machinery. 278 pages, 6 in. by 9 in. Illustrated. Bound in cloth. Published by the Industrial Press, 140 Lafayette street, New York. Price \$2.50.

During the past two decades developments have taken place in the processes involved in the building of machinery as well as in the materials of construction, which have produced many changes in the heat-treatment of steel. The introduction of high speed steel for cutting tools and the various alloy steels, the usefulness of which depends almost entirely upon proper heat-treatment, has made necessary the careful study of processes and has produced many remarkable changes in practice. In the preparation of this book it has been the purpose to place on record the modern methods of heat-treatment, and although largely descriptive in its dealing with the subject, the book will be found to contain much practical data of value to those who have to do with heat-treating operations.

The first chapter is devoted to a theoretical discussion of the effect of heat-treatment and a brief digest of the results to be obtained by various methods of treating carbon and alloy steels. In the following chapters the various processes of hardening, quenching, tempering, annealing and casehardening are described in detail, the text being amplified by numerous engravings showing the construction and methods of operation of the furnaces and other appliances. The application of the electric furnace to heat-treating operations is dealt with at considerable length and a chapter is included on the newly developed method of case-hardening by carbonaceous gas.

A brief treatise is included on the methods used to measure the hardness of metals. Various types of hardness testing machines, developed in this country and abroad, are described and the principles on which they operate set forth.

The information contained in the book has been mainly compiled from articles published in Machinery and from the well known Machinery Reference Books, and it forms a very comprehensive treatise on a subject about which little of a practical nature has been written.

COMMUNICATIONS

PRACTICE VERSUS THEORY IN DESIGN

NEW YORK, N. Y.

TO THE EDITOR:

On page 451 of your September, 1914, issue you print an interesting editorial entitled "A Word of Thanks." You therein invite a "frank and square-from-the-shoulder criticism" of things you publish. I wish to accept your invitation and "hand you one" on the subject of co-operation. In your "Word of Thanks" you say your whole heart and soul is set on bettering things in your particular field, etc., and in the final paragraph you state the truism: "After all, we are really one big association with one common interest, and each one of us owes it to all the others to do our little part in making the mechanical department more effective and more efficient." With the next stroke of your editorial pen, however, you excite discord where harmony and co-operation are of the utmost importance to the "common interest" for which you had just appealed. I refer to your editorial, "Limitations of The Designer." Damage is done by your editorial because you cite a specific case and from it draw a general conclusion, and in doing so you furnish fuel for the fire of antagonism between the "practical" and the "theoretical," which is such a serious detriment to progress in any industry.

The designer in a railroad organization is never an independent unit with authority to depart from standards and arrange apparatus to suit himself. The designer is, however, a member of the big association, specially trained in the theory of mechanics and in the work of reducing to a tangible and practical form on the drafting table the various features and arrangement of parts desired in a device or machine. The perfection of the result will depend largely on the thorough study given to the details of the design *in order that it may incorporate all the good features which the operation and maintenance of such machines have shown to be advisable.* Here is where the co-operation of the practical and theoretical is of the utmost importance, and the head of the department or the one responsible for the finished result of the designer's work should see to it that the designer not only co-operates, as in this case, with the man who has "spent his life running locomotives," but also with the man who spends his life in maintaining locomotives. For example, see "Air Brake Repairs," page 165, Railway Age Gazette, July 24, 1914.

Great progress has already been made by the patient and constructive analysis of existing designs of apparatus through the co-operation of the manufacturer, operating men and designing engineers in an effort to perfect the design for the good of the common interests. This good work will go on and further improvements will be made when the hearty co-operation of every individual of our "one big association" is enlisted in the desire for the success of the new design, be it of a car, locomotive, shop or other equipment for the road. In the editorial you give credit to the mechanical engineer for the design of a particularly good box car, because of co-operation with the operating men. Why, then, blame the designer when the same co-operation was not insisted upon in the engine design?

Co-operation cannot be secured by a jerk, but by the steady pulling together of all the many members of the "big association" of the railway industry. The united efforts of so many experienced and trained minds will eventually result in remarkable improvements in working conditions and in operating costs.

We all have our limitations, even editors, as witness the appeal for help in your "Word of Thanks." If the editor of a great journal needs help through co-operation with the "practical," how much more must the designer need such help? In conclusion, I refer to the final sentence of your

editorial, "A Word of Thanks," and hope that this communication may "help the editor" to co-operate with the designer in enlisting the aid of the "practical" in the perfecting of the work intrusted to him.

F. M. BRINCKERHOFF.

THE BONUS SYSTEM

TOLEDO, Ohio.

TO THE EDITOR:

While I have read many criticisms of the bonus system for the payment of labor, I believe that such a system can be established in any manufacturing plant by a capable efficiency engineer. This has been proved by the results of such installations in many cases.

The reasons for the failure of the bonus system in so many instances are not the faults of the system itself but may be traced to the short-comings of the so-called expert who is responsible for the many radical changes both in organization and shop practice which usually accompany the installation of a bonus system. The expert is very frequently deficient in a number of ways. He often has to learn the business of his client at the client's expense; he possesses too much egotism; his work is frequently too largely based on theory unbacked by practical experience. He is seldom well enough acquainted with the design of machinery, tools, jigs and fixtures. Through lack of tact he antagonizes the workmen, who in turn can very easily make impossible the determination of a basis for a fair standard. His standards are often the result of rough estimates which may do injustice either to the workmen or to the management.

To be worthy of the title of efficiency engineer one should be an engineer capable of directing the design of labor-saving devices such as special tools, jigs and fixtures. He should be able to locate machine tools for the most economical production. He should thoroughly understand the bonus system; but it is not worth while to make time studies for the purpose of establishing standards of performance for the workmen until the location of the machinery has been thoroughly investigated and until the best possible use of jigs, templates and other special tools has been made. He should be able to set up work in a machine and operate it himself, such an accomplishment being invaluable in securing the confidence and respect of the workmen. He should have the good judgment necessary to establish standards of performance which will prove satisfactory, both to the workmen and to the management. I have known so-called experts, in arriving at standards for automatic machines, to speed them up to their maximum production, thereby setting a standard so high that the workmen were never able to earn a bonus.

W. H. WOLFGANG.

TEMPERATURE INDICATING PAINT.—A paint which changes color at various temperatures has recently been brought out in Europe, says F. J. Rankin of the Colorado Agricultural College. When applied to iron work it is a visual indicator of the running condition of a machine or other apparatus. The paint is red at ordinary temperatures but turns black when heated, becoming red again on cooling. It is claimed that the color will always follow the temperature, no matter how many times the cycle is repeated.—*Iron Age.*

METRIC SYSTEM IN CHINA.—China recently enacted a weights and measures law in which the meter and kilogram are prescribed as the sole standards, although the old system of measures is still recognized. The units of the old system are defined in metric terms, the length unit being exactly 32 centimeters. The metric units are given the same names in the Chinese language as the nearest old units, but to each is given the prefix "sin," which means "new." Thus the meter will be known as "sin-tchi," and the kilogram as "sin-king." The metric system was not made compulsory at the outset, the date of compulsory application of the act being fixed later.

RECIPROCATING AND REVOLVING PARTS

Beginning a Series of Articles Dealing With Their Design and Improvements Which Are Possible

BY H. A. F. CAMPBELL*

I—AMERICAN DESIGN

The late S. L. Barnes once said "The practical problem of balancing is not one of how to balance, but of reducing the total weight of the reciprocating parts to a minimum."

The size of the present day passenger and freight locomotive has made it more necessary than ever to keep the weight of the reciprocating parts down to a minimum. A certain Pacific type locomotive now in service has a piston and piston rod weighing 900 lb., a crosshead 560 lb., and a main rod 970 lb. When this engine is running a mile a minute, the force of the inertia of these reciprocating weights at the end of each stroke is about 80,000 lb. or 40 tons. The excess weight in each driver to balance two-thirds of these reciprocating parts causes a dynamic augment on the rail 50 per cent greater than the static weight on each wheel. This means a total variation between the maximum and the minimum weight of 100 per cent of the static weight on any wheel point. The inertia of these reciprocating weights acts at a distance of three feet from the center line of the locomotive, producing a large unbalanced couple tending to nose the engine. Even the revolving weights in the main wheels, owing to their size, are far out of the plane of their balance weight in the wheel. This creates another unbalanced couple that tends to rock the axle across the engine.

The amount of steam force necessary to accelerate or decelerate these reciprocating masses reduces the evenness of the final turn-

ing moment at the crank pin. This reduces the effective drawbar pull, especially at high speeds.

The American railways seem to have decided that the two-cylinder locomotive is a necessity, and to have given up any idea of utilizing three or four cylinders. That is, no matter how great the power to be developed, it has got to be carried by only two sets of driving gear. To do this means that the engine has got to carry as much as 150,000 lb., or 75 tons, on one set of driving gear, consisting of a piston, piston rod and crosshead, wrist pin, main and side rods and crank pins. The largest freight locomotives now have 13 in. diameter main axles and 10½ in. diameter main crank pins; a few years ago the dimensions of this pin would have been considered sufficient for a good-sized axle. If the weight of the parts necessary to carry such loads is to be kept anywhere within reason, great care and refinement in design is imperative. Even then the weights may be too great, and a study of the further reduction of weight by the use of heat treated carbon steel, or of alloy steels, will become necessary.

Before studying in detail the actual present practice in the design of these parts I wish to present a few tables of weights in order to show that the average practice of today is not nearly as good as it was 15 years or more ago. This may seem surprising, but it is a fact. Broadly speaking, the weight of the piston, piston rod, crosshead and connecting rod should be proportional to the piston load that they have to carry. The tables, I to V, give data connected with the reciprocating parts of a

*Baldwin Locomotive Works, Philadelphia, Pa.

TABLE I, DATA FOR RECIPROCATING PARTS OF FREIGHT LOCOMOTIVES BUILT BEFORE 1904

Road and type	Cylinders and driving wheels	Boiler pressure, lb.	Piston load, lb. (area piston x full b. press.)	Weight, lb.			Total wt. of reciprocating parts, lb.	Piston load carried, lb.			
				Cross-head	Piston and rod	Main rod		per lb. wt. rec. parts	per lb. wt. crosshead	per lb. wt. piston	per lb. wt. main rod
Penn., 2-8-0	22 in. x 28 in.; 57 in.	205	77,900	284	407	615	967	80	274	191	126
Nat. of Mexico, 2-8-0	21 in. x 30 in.; 56 in.	200	69,200	365	433	795	1,155	60	189	160	87
Southern Pacific, 2-8-0	22 in. x 30 in.; 57 in.	200	76,000	343	516	750	1,196	63	221	147	101
Mex. Inter., 2-8-0	22 in. x 28 in.; 57 in.	200	76,000	365	537	835	1,280	59	208	141	91
B. & P., 2-8-0	22 in. x 28 in.; 56 in.	200	76,000	352	437	942	1,213	62	216	173	80
Woodward Iron Co., 2-8-2	22 in. x 28 in.; 51 in.	200	76,000	567	392	745	1,294	59	134	194	102
Average								64	207	167	98

TABLE II, DATA FOR RECIPROCATING PARTS OF FREIGHT LOCOMOTIVES BUILT SINCE 1904

Road and type	Cylinders and driving wheels	Boiler pressure, lb.	Piston load, lb. (area piston x full b. press.)	Weight, lb.			Total wt. of reciprocating parts, lb.	Piston load carried, lb.			
				Cross-head	Piston and rod	Main rod		per lb. wt. rec. parts	per lb. wt. crosshead	per lb. wt. piston	per lb. wt. main rod
C. B. & O., 2-10-2	30 in. x 32 in.; 60 in.	175	123,700	706	1,022	1,305	2,315	53	175	121	94
C. B. & O., 2-8-2	28 in. x 32 in.; 64 in.	180	110,900	706	860	1,238	2,123	52	157	128	90
Virginian, 2-8-2	26 in. x 32 in.; 56 in.	185	98,200	691	715	975	1,845	53	142	137	100
Gt. Northern, 2-8-2	28 in. x 32 in.; 63 in.	170	104,700	616	873	1,060	1,966	53	170	120	99
Lehigh Valley, 2-8-2	27 in. x 30 in.; 56 in.	175	100,000	582	855	1,065	1,916	52	171	117	94
Rock Island, 2-8-2	28 in. x 30 in.; 63 in.	180	110,900	642	1,034	1,110	2,176	51	172	107	100
Erie, 2-8-2	28 in. x 32 in.; 63 in.	170	104,700	553	760	1,045	1,785	59	189	137	100
B. & O., 2-8-2	26 in. x 32 in.; 64 in.	190	101,000	576	760	905	1,743	58	175	133	111
A. T. & S. Fe., 2-8-2	25 in. x 32 in.; 57 in.	170	83,500	622	754	932	1,795	46	134	110	89
Woodward Iron Co., 2-8-2	24½ in. x 30 in.; 55 in.	200	94,300	530	665	930	1,613	58	177	141	101
N. O. M. Co., 2-8-2	22 in. x 28 in.; 57 in.	185	70,300	408	471	730	1,207	58	149	149	96
B. & O., 2-10-2	30 in. x 32 in.; 58 in.	190	134,000	812	1,180	1,475	2,656	49	165	113	90
Average								53½	165	126	97

TABLE III, DATA FOR RECIPROCATING PARTS OF PASSENGER LOCOMOTIVES BUILT BEFORE 1904

Road and type	Cylinders and driving wheels	Boiler pressure, lb.	Piston load, lb. (area piston x full b. press.)	Weight, lb.			Total wt. of reciprocating parts, lb.	Piston load carried, lb.			
				Cross-head	Piston and rod	Main rod		per lb. wt. rec. parts	per lb. wt. crosshead	per lb. wt. piston	per lb. wt. main rod
Penn., 4-4-0	18½ in. x 26 in.; 68 in.	185	50,000	169	266	373	568	88	300	188	134
D. L. & W., 4-4-0	20 in. x 26 in.; 69 in.	185	58,000	188	390	595	816	71	308	148	97
N. R. R. Mexico, 4-6-0	20 in. x 26 in.; 68 in.	200	62,800	322	372	670	995	63	195	169	93
C. & A., 4-4-2	20 in. x 26 in.; 81 in.	200	62,800	343	453	718	1,119	56	183	137	88
U. P., 4-6-2	25 in. x 28 in.; 77 in.	200	76,000	343	502	725	1,171	65	221	151	105
A. & B., 4-6-0	19 in. x 26 in.; 63 in.	180	51,000	265	357	515	853	59	192	143	100
C. & A., 4-4-2	20 in. x 28 in.; 80 in.	200	62,800	365	429	795	1,152	54	172	146	79
P. & R., 4-4-2	21 in. x 24 in.; 84 in.	220	76,000	352	437	942	1,213	63	216	174	80
C. & A., 4-6-2	22 in. x 28 in.; 80 in.	200	76,000	365	560	805	1,287	60	208	136	94
N. Y. N. H. & H., 4-6-0	27 in. x 26 in.; 73 in.	200	62,800	298	476	766	1,121	56	210	132	82
N. Y. C. & St. L., 4-6-0	20 in. x 26 in.; 72 in.	200	62,800	330	405	726	1,062	59	190	155	96
Average								63	218	153	95

TABLE IV, DATA FOR RECIPROCATING PARTS OF PASSENGER LOCOMOTIVES BUILT SINCE 1904

Road and type	Cylinders and driving wheels	Boiler pressure, lb.	Piston load, lb. (area piston x full b. press.)	Weight, lb.			Total wt. of reciprocating parts, lb.	Piston load carried, lb.			
				Cross-head	Piston and rod	Main rod		per lb. wt. rec. parts	per lb. wt. crosshead	per lb. wt. piston	per lb. wt. main rod
Penn., 4-6-2	26 in. x 26 in.; 80 in.	205	109,000	491	650	1,065	1,624	67	215	169	102
C. C. & O., 4-6-2	25 in. x 30 in.; 69 in.	200	98,000	535	670	925	1,613	60½	183	146	106
N. Y. N. H. & H., 4-6-2	24 in. x 26 in.; 79 in.	200	83,000	369	640	922	1,423	58½	225	130	90
C. G. W., 4-6-2	25 in. x 28 in.; 73 in.	190	93,300	493	742	886	1,633	57	190	125	105
C. & O., 4-6-2	27 in. x 28 in.; 73 in.	185	105,800	561	907	971	1,905	55	188	116	109
B. & O., 4-6-2	24 in. x 28 in.; 76 in.	190	85,900	595	660	890	1,655	51½	144	130	103
N. Y. C., 4-6-2	26 in. x 28 in.; 79 in.	200	106,200	585	787	920	1,786	48½	180	134	115
Lehigh Valley, 4-6-2	25 in. x 28 in.; 77 in.	210	103,000	445	704	850	1,531	67	231	146	121
Average								58	194	137	106

TABLE V, DATA FOR RECIPROCATING PARTS OF LOCOMOTIVES BUILT IN 1914, WITH ESPECIALLY LIGHT PARTS

Road and type	Cylinders and driving wheels	Boiler pressure, lb.	Piston load, lb. (area piston x full b. press.)	Weight, lb.			Total wt. of reciprocating parts, lb.	Piston load carried, lb.				Reference for photograph
				Cross-head	Piston and rod	Main rod		per lb. wt. of rec. parts	per lb. wt. crosshead	per lb. wt. piston	per lb. wt. main rod	
Penn., 4-6-2	27 in. x 28 in.; 80 in.	205	114,000	491	520	930	1,376	83	320	219	122	
Penn., 4-4-2	23½ in. x 26 in.; 80 in.	205	89,000	327	408½	720	1,014	87	271	218	123	Fig. 1
Penn., 2-8-2	27 in. x 30 in.; 62 in.	205	114,000	532	516	939	1,470	77	214	220	121	Fig. 2
P. & R., 4-4-0	21 in. x 24 in.; 68½ in.	220	76,200	302	464	590	1,031	74	252	164	130	Fig. 30
C. B. & Q., 2-10-2	29 in. x 32 in.; 60 in.	175	123,700	526	945	1,035	1,936	64	235	130	119	Fig. 19
Average								77	258	190	123	

number of locomotives; then follows the most important part—the amount of piston load carried per pound of weight of the parts collectively and of each part separately. The average figures are given at the bottom of each table. The tables have been divided into passenger and freight locomotives built before 1904 and since 1904, and a fourth table is given including five engines built recently, in which exceptional care has been taken in the matter of designing the reciprocating and revolving parts.

If the reader grasps the substance of these tables, it will enable him, without going over a lot of data, to see that we are not doing as well in respect to the design of reciprocating parts, as we did in the past on smaller engines. An examination of the first engine given in each table, freight and passenger, will show cases before 1904 that are so far above the average as to be striking; and one of the passenger engines is not only above the average, but it is better in nearly every weight per load carried

unit of work done may be reduced. Light parts do not necessarily mean weak parts, but may mean stronger parts.

The designers of the automobile and the flying machine, by using great care in detail design, and by the use of high grade steel, have reduced the weight of their moving parts to a marvelous degree. The locomotive engineer can do the same when he makes up his mind that it is necessary and decides to start anew, determined to obtain definite results in weight reduction. In the remainder of this article it is the intention to show in detail the notable results obtained in the design of the reciprocating parts of several locomotives built in 1914.

The Pennsylvania Railroad in 1914 built very heavy and powerful Atlantic (see Fig. 1) and Pacific type locomotives,* both of which have a very heavy weight on drivers. To safely permit the use of such a weight it was imperative that the excess counterbalance weight in the drivers should not exceed a certain figure at a given speed. It was determined that at 70 miles per

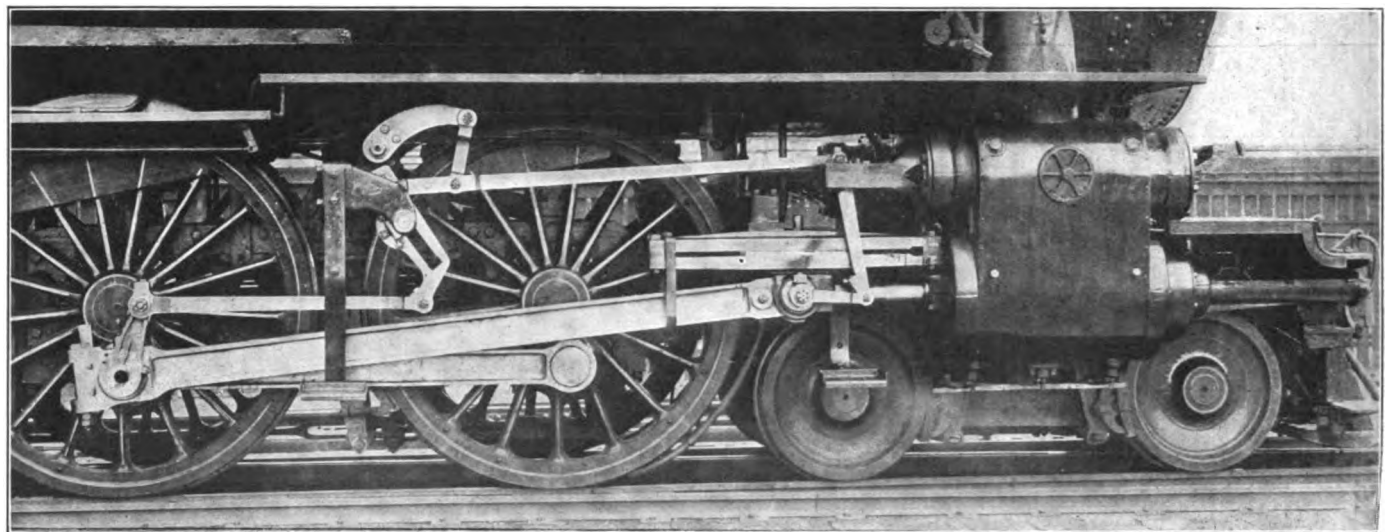

Fig. 1—Running Gear of Pennsylvania Railroad Atlantic Type Locomotive, Class E6s

hour the centrifugal force of the excess weight in the driving wheels should not exceed 30 per cent of the static weight on a wheel point; or, to state it another way, the variation between the maximum weight and the minimum weight on a driver should not exceed 60 per cent of the static weight. This definitely

hour the centrifugal force of the excess weight in the driving wheels should not exceed 30 per cent of the static weight on a wheel point; or, to state it another way, the variation between the maximum weight and the minimum weight on a driver should not exceed 60 per cent of the static weight. This definitely

This brings us to the main thought which the writer wishes to bring out in this paper, and to a fact that each reader should consider carefully. As the size and power of the locomotive is increased, the moving parts per unit of work to be done need not be increased in weight. On the contrary their weight per

*A description of the Pennsylvania Atlantic type locomotive, class E6s, was published on page 63 of the *Railway Age Gazette, Mechanical Edition*, for February, 1914, and a description of the Pacific type locomotive, class K4s, and the Mikado type, class L1s, Fig. 2, was published on page 34 of the July, 1914, issue.

settled what the reciprocating parts must weigh, and in order to bring the weight of the parts within this limit it was found that only 60 per cent of the reciprocating parts could be balanced. The weights of these parts are given in table VI.

TABLE VI—WEIGHTS OF RECIPROCATING PARTS OF PENNSYLVANIA LOCOMOTIVES

Name of part	Weight, lb.	
	Atlantic, E6s	Pacific, K4s
Piston, piston rod, extension rod, crosshead and key	408.5	520
Crosshead and wrist pin	312	480
Lap and lead lever connector	15	11
Front end of main rod	279.5	365
Back end of main rod	440.5	565

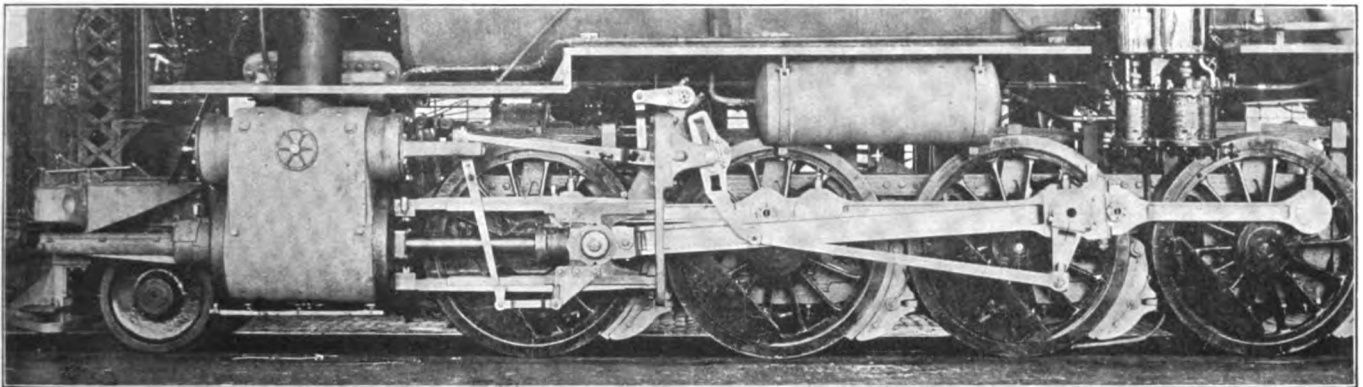

Fig 2—Running Gear of Pennsylvania Railroad Mikado Type Locomotive, Class L1s

Total main rod	720	930
Front end of side rod	186	136
Back end of side rod	231	162.5
Side rod (main pin)	534.5
Rear end eccentric rod (equivalent at 13 in. radius)	22.7

The material for the main and side rods, piston rod, pins and valve motion parts is silico-manganese carbon steel, heat treated, with the following characteristics:

Carbon0.50 per cent	Ultimate strength	85,000 lb. per sq. in.
Manganese0.55 per cent	Elastic limit	50,000 lb. per sq. in.
Silicon0.20 per cent	Elongation in 2 in.20 per cent
PhosphorusNot over 0.03 per cent	Reduction in area40 per cent
SulphurNot over 0.03 per cent		

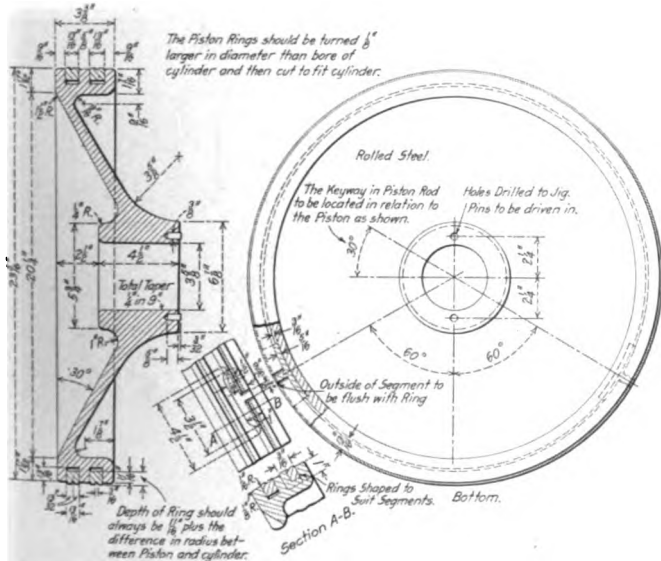

Fig 3—Piston of Pennsylvania Atlantic Type Locomotive

The pistons are made of rolled open hearth carbon steel. The crossheads are of cast steel made by the electric furnace process, with the following qualities:

Carbon0.40 per cent	Ultimate tensile strength	70,000 to 80,000 lb. per sq. in.
Manganese0.48 to 0.60 per cent	Elongation in 2 in.	12 to 25 per cent
Silicon0.22 to 0.28 per cent		

Until a designer has actually tried, he does not realize what it

means to produce such light parts and still retain the required strength. Figs. 3, 4, 5, 6 and 7 show the piston, piston rod, crosshead, main rod and side rods for the Atlantic type locomotive class E6s, and Figs. 8, 9, 9A, 10, 11 and 12 for the Pacific type, class K4s. The unit stresses have been noted on the drawings at the different sections. They are based on a maximum piston load equal to the product of the area of the piston and the full boiler pressure and a proportion of the main rod load on the side rods, in the case of the Atlantic type 80 per cent, of the Pacific type 70 per cent.

The pistons are of rolled steel of umbrella shape and are of extremely light section. The unit stress has not been deter-

mined, as there is no really satisfactory formula for the design of pistons. Unwin's, Seaton's and Bach's formulas are all well known, and the designer may possibly use them all as a guide; but in the last analysis he must use his judgment, especially with this shape of piston, as it is known to be actually stronger than any of the formulas will show. It will be noted that no cast iron wearing shoe is used, and that the wearing surface of the rim is only 3½ in. wide, but the piston rod has an extension tail rod. If the extension rod had not been used, the employment of such a narrow wearing surface as 3½ in. would hardly have seemed wise, and it is possible that a cast iron bull-ring might have had to be used. But with a wider ring made of cast

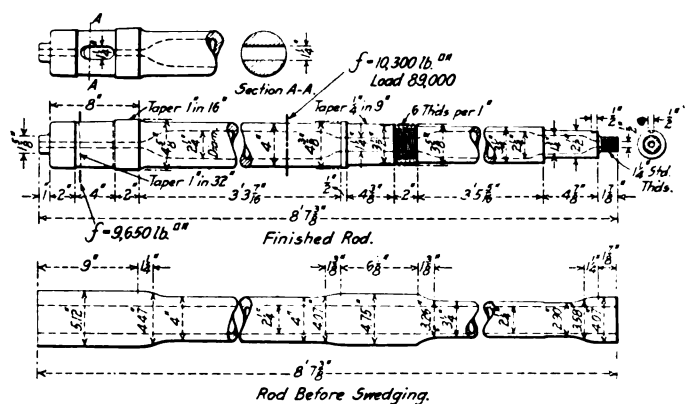

Fig. 4—Piston Rod of Pennsylvania Atlantic Type Locomotive

iron, and no extension tail rod, the weight would have been greater than the piston head, even allowing for the added weight of the extension piston rod and the sliding shoe. There is a belief that an extension piston rod, unless it is very stiff and kept carefully lined up, is of little value, but a hollow extension rod of large diameter can be made stiff and at the same time very light.

The details of the piston rod and its extension and the rod extension shoe are clearly shown in Figs. 4, 9 and 9A. These rods are made of carbon steel, heat treated. The method of manu-

fracture is clearly shown; the rod is forged and then hollow bored throughout its length. The necessary sections are then swaged down as shown in the finished rod. The load and unit

stresses are noted. Although this rod is extremely light, it is stiff in compression and flexure, and there should be no reason for its causing trouble.

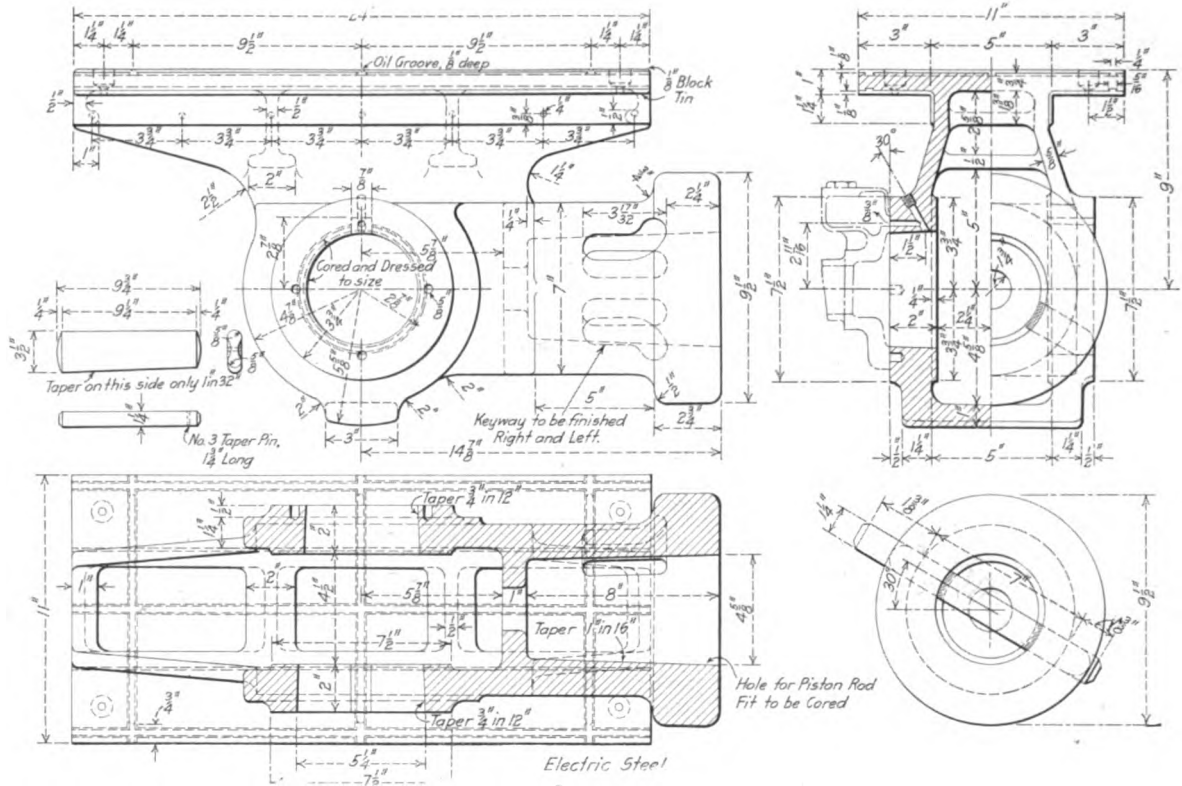

Fig. 5—Crosshead of Pennsylvania Atlantic Type Locomotive

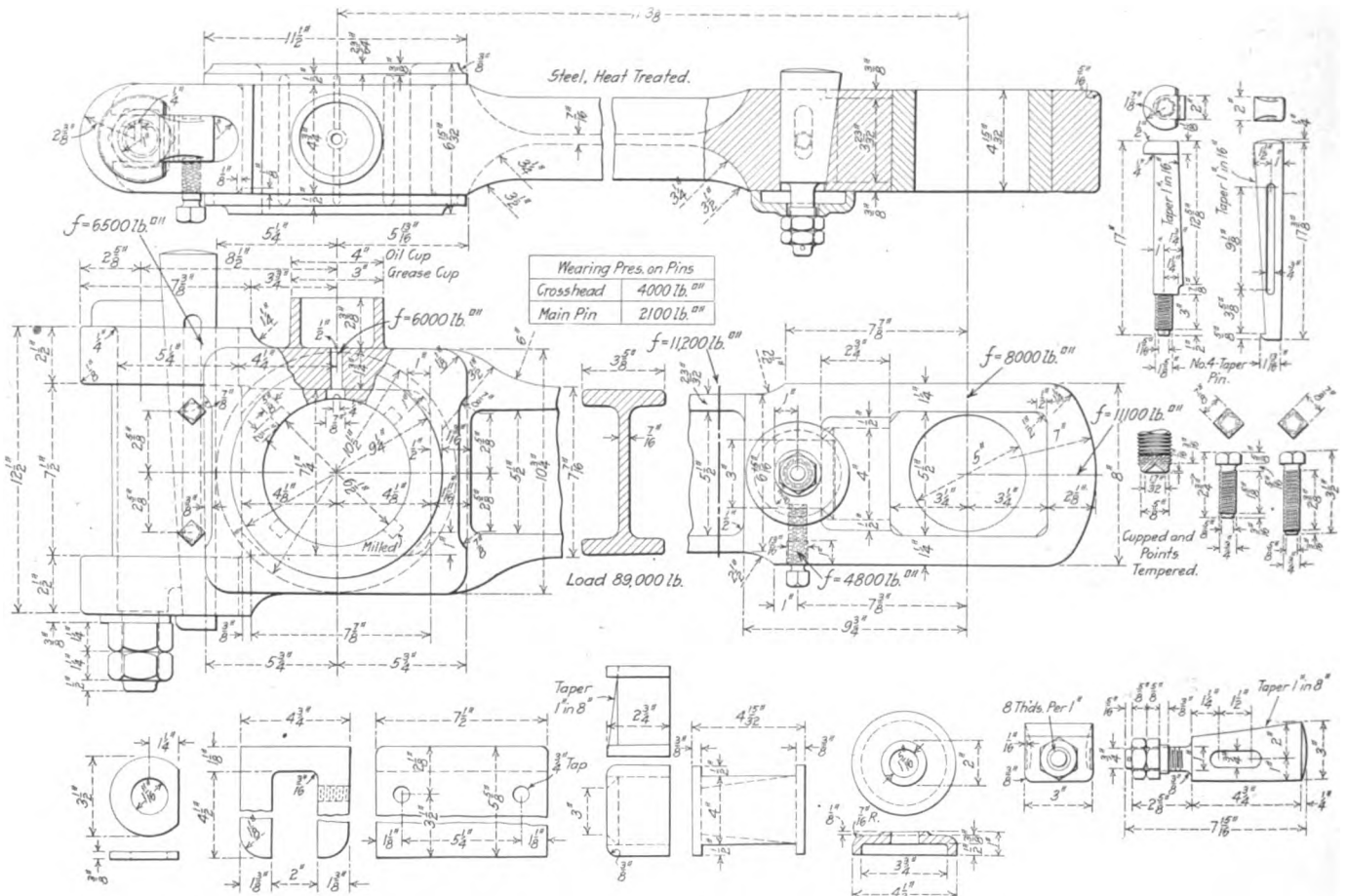

Fig. 6—Main Rod of Pennsylvania Atlantic Type Locomotive

The crossheads are shown in Figs. 5 and 10. This type of crosshead has been standard on the passenger engines of the Pennsylvania Railroad and on many New Haven engines for

based on a load equal to the area of the piston times the full boiler pressure. These stresses are conservative.

TABLE VII—STRESSES IN PISTON ROD AND CROSSHEAD OF PENNSYLVANIA LOCOMOTIVES

Section; and nature of stress	Amount of stress, lb. per sq. in.	
	Atlantic type, E6s	Pacific type, K4s
Shear on key	10,500	10,900
Tension in rod through keyway	9,650	10,500
Tension in neck of crosshead through keyway	4,700	3,550
Crushing of key on the rod	16,500	17,800

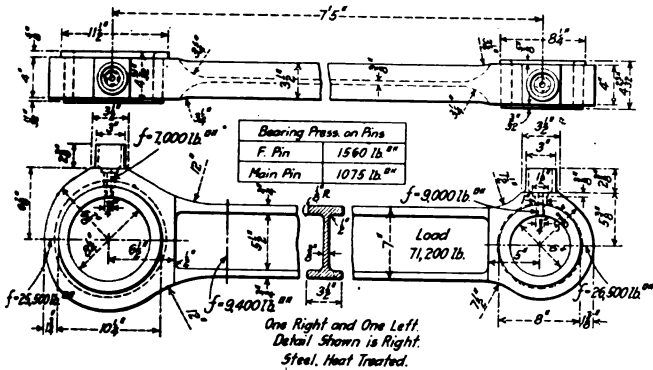

Fig. 7—Side Rod of Pennsylvania Atlantic Type Locomotive

years. With the exception of the old style crosshead with a solid wrist pin and using four-bar guides, as shown in Fig. 9B, it is the lightest type of crosshead made, in relation to its strength.

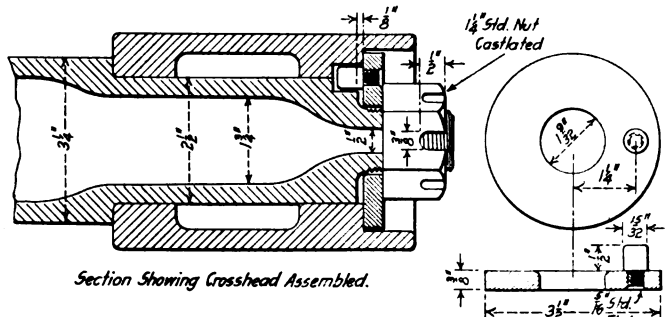
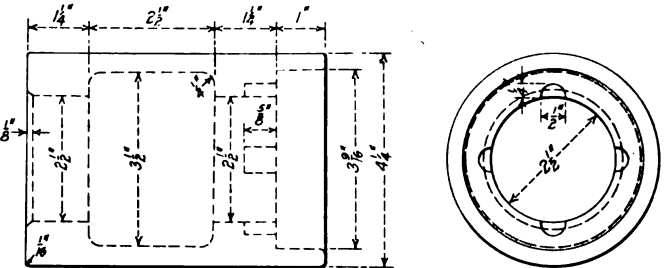

Fig. 9A—Extension Shoe for Piston Rod Shown in Fig. 9

Crushing of key on crosshead	16,200	13,800
Bearing pressure, pin on crosshead	4,450	4,600
Compression in main shank of piston rod	10,300	10,400

The crossheads have ample gib surface and bearing surface where the pin bears on the crosshead, a very essential point. The oiling of the wrist pin has been carefully worked out and is clearly shown in the drawings. The lap and lead connecting link is driven from an extension of the wrist pin. Studying these cross-

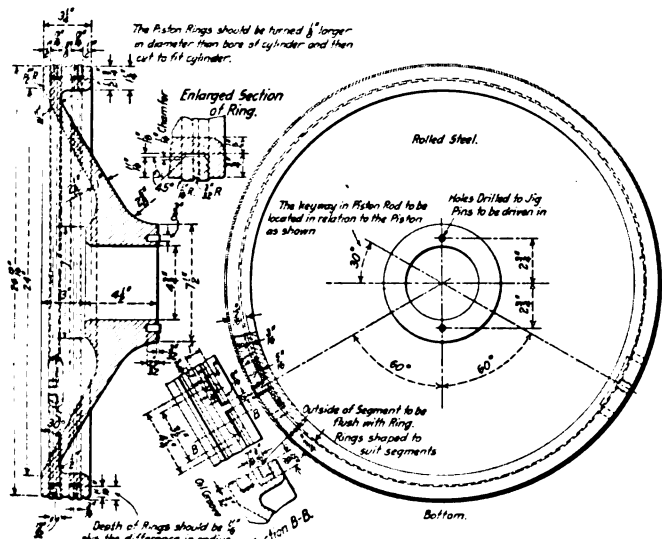

Fig. 8—Piston of Pennsylvania Pacific Type Locomotive

These crossheads are made of 0.4 carbon steel by the electric furnace process, and the railway officers state that this is the

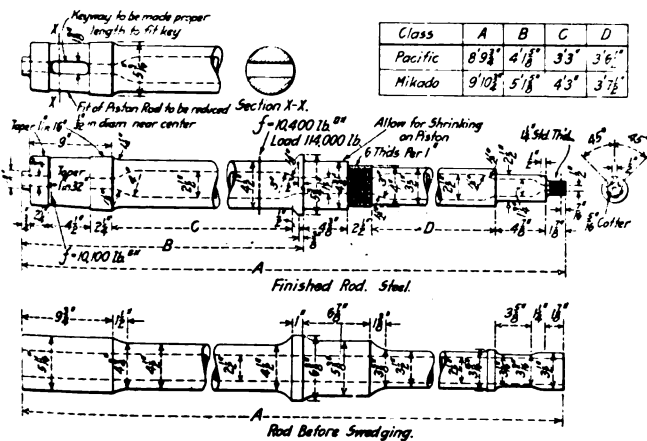

Fig. 9—Piston Rod of Pennsylvania Pacific Type Locomotive

only method that insures these castings being sound. The unit stresses on the various sections are given in Table VII and are

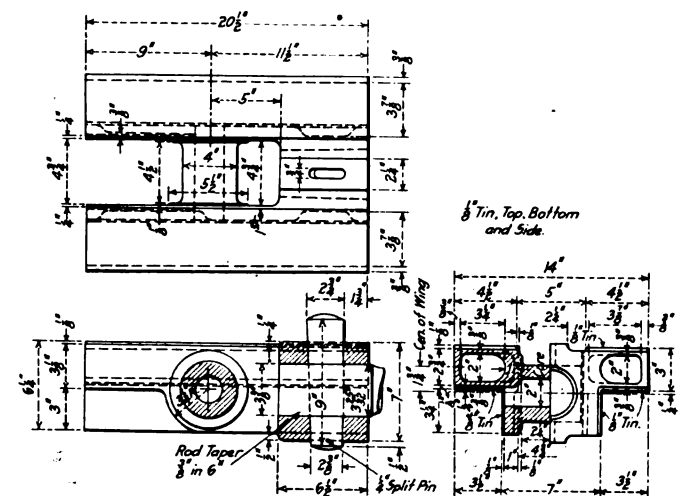

Fig. 9B—Four-bar Crosshead

heads in detail it will be found that no unnecessary metal has been put into them; the one point that may be raised is that they are not as strong when the engine is running backwards and therefore are unsuitable for freight engines.

The main and side rods for the Atlantic type, class E6s, are shown in Figs. 6 and 7, and for the Pacific type, class K4s, in

Figs. 11 and 12. These rods are made of open hearth carbon steel, heat treated. The loads and unit stresses at the different

back stub of the main rod follows the railway's standard practice. This is a strong, light stub, but the writer does not believe

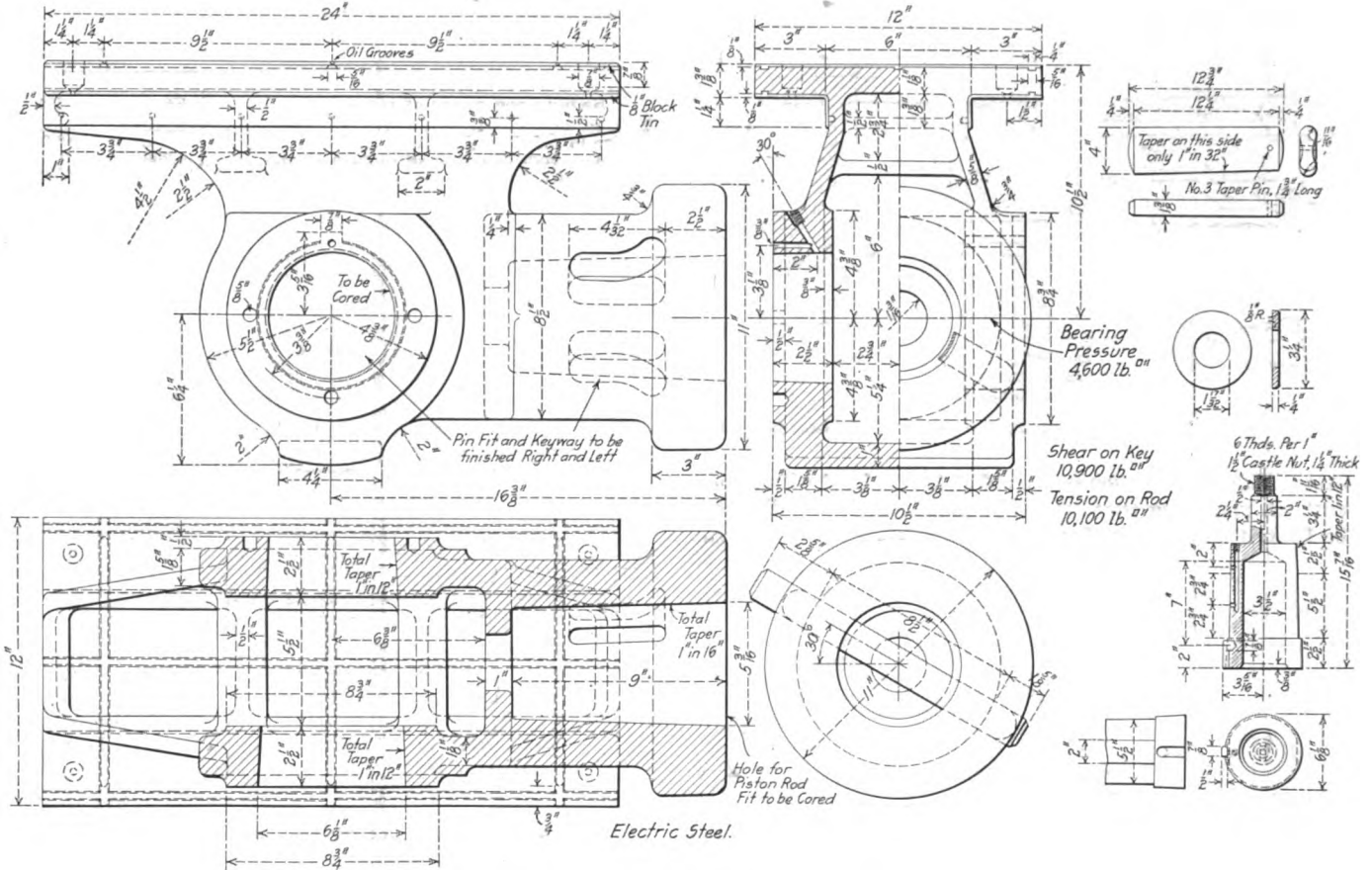

Fig. 10—Crosshead of Pennsylvania Pacific Type Locomotive

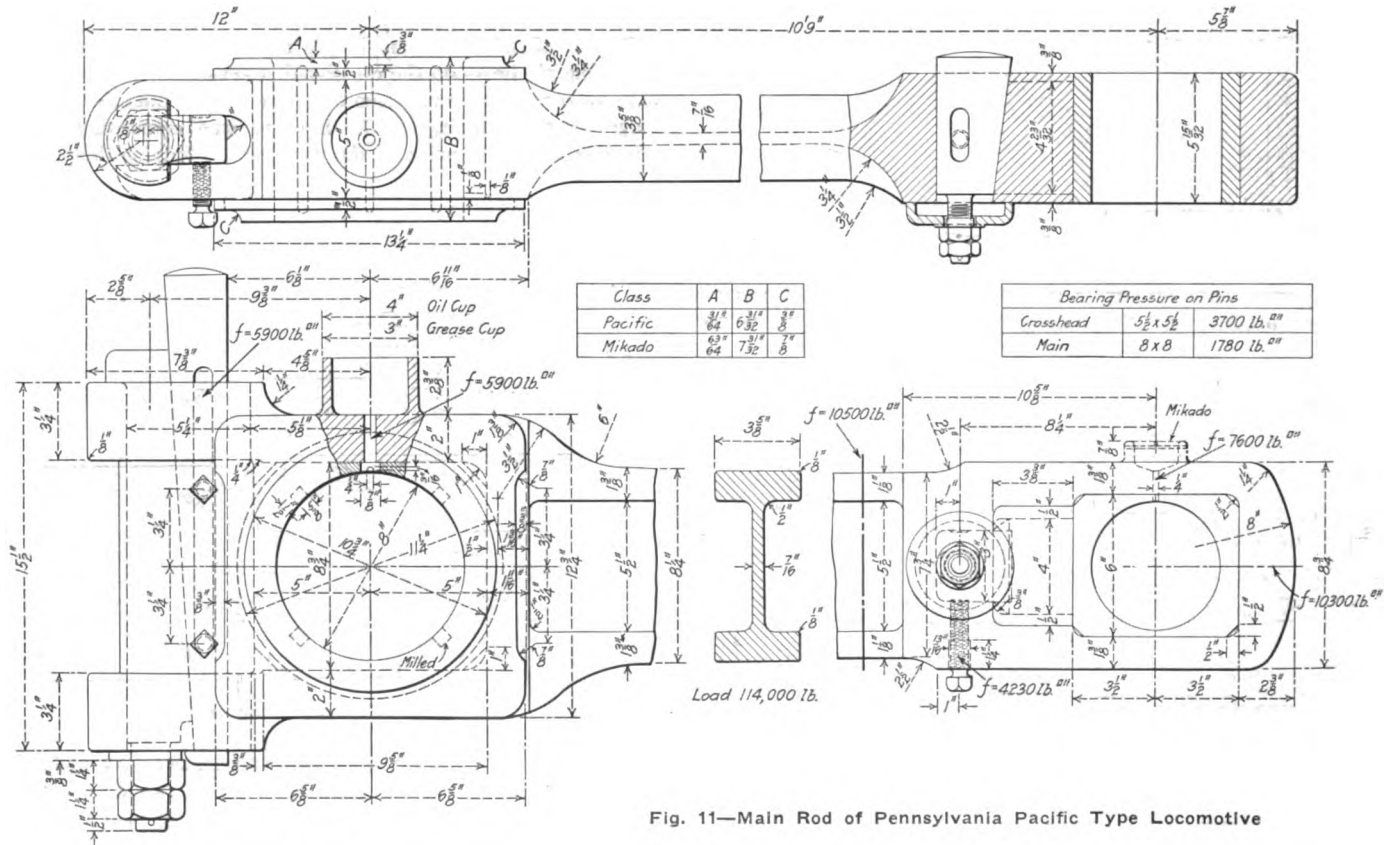

Fig. 11—Main Rod of Pennsylvania Pacific Type Locomotive

sections are noted on the drawings and are given in table VIII. Great care has been given to every detail of these rods. The

that it can be made any lighter than a stub that uses a strap and bolts. The side rods have been made unusually deep, giving a

correspondingly low whip stress at high speeds. The knuckle pin of the side rods, Fig. 12, seems unusually large, but this size is used to keep the bearing pressure per square inch down to

UNCOUPLING LEVER FOR SWITCH ENGINES

BY GEORGE E. McCOY

TABLE VIII—STRESSES IN MAIN AND SIDE RODS OF PENNSYLVANIA LOCOMOTIVES

Section; and nature of stress	Amount of stress, lb. per sq. in.	
	Atlantic type, E6s	Pacific type, K4s
Main rod, I section.....	11,200	10,500
Crosshead stub, tension.....	8,000	7,600

A design of uncoupling lever which is being successfully used on the front and rear ends of switch engines on the Intercolonial Railway is shown in the accompanying drawing. It replaces the old style of lever which extend across the locomotive in one piece with an operating handle at either end.

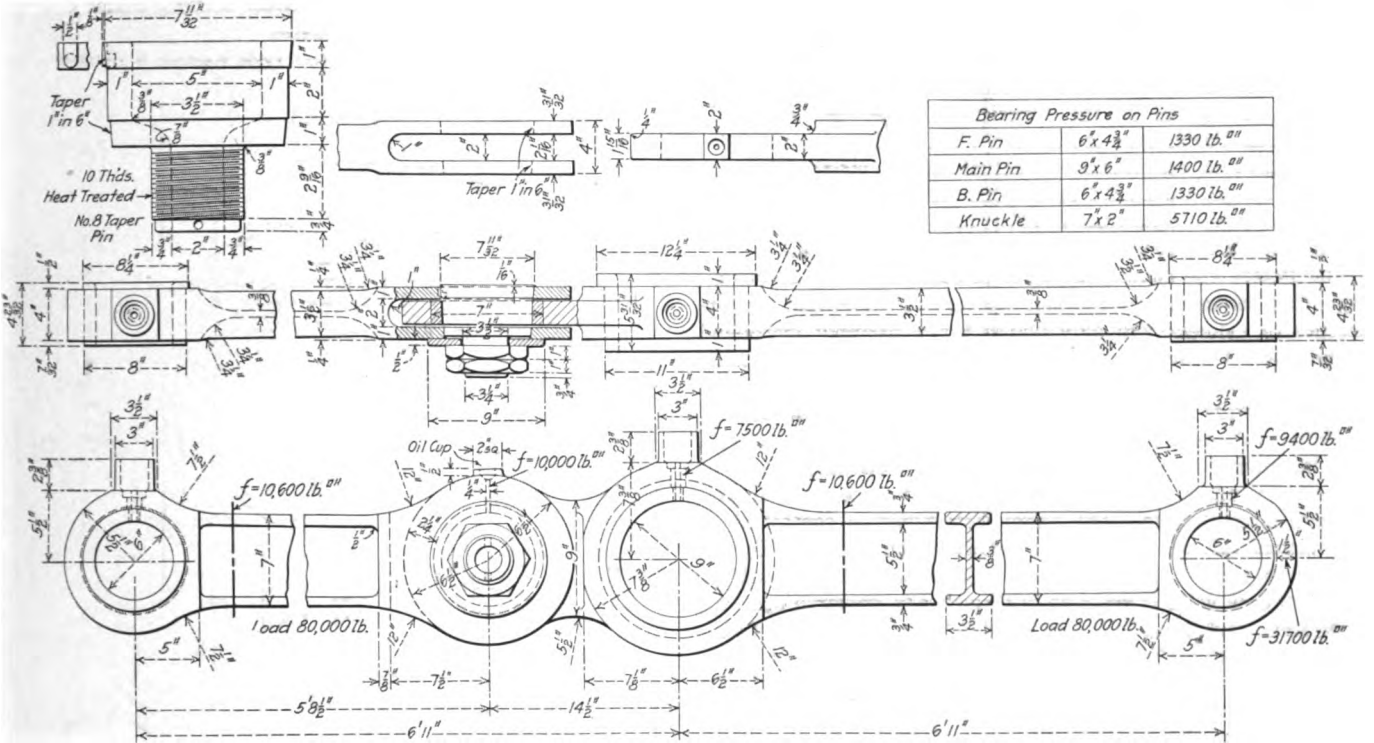

Fig. 12—Side Rods of Pennsylvania Pacific Type Locomotive

Crosshead stub, bending.....	10,500
Main stub strap, tension.....	6,000
Side rod, I section.....	9,400
Front and back stub eye, tension.....	9,000
Front and back stub eye, bending.....	26,500
Main side rod stub, tension.....	7,500
Main knuckle eye, tension.....	10,100

The old style lever was objected to because of the danger of injury to a person standing near the end of the footboard when the lever was being operated from the opposite end. In the new

standard practice. Knuckle pins are often made too small and show very rapid wear because of lack of ample bearing surface. Another point in favor of this knuckle pin is that, being large in diameter and narrow, it gives an action more like a spherical pin. This is important because there is no doubt that many side rod failures are due to a twisting action on the rods, produced by the rod ends getting out of line with each other. A ball knuckle pin will greatly relieve this cross twisting strain. The I sections of the rods are broad, and slim, a type of section that has been extensively used on the road.

[EDITOR'S NOTE.—The remaining section of Part I of this series will be published in an early issue.]

HARDNESS TESTING.—If in testing for hardness by the Brinell process it is necessary to use a V-block when testing the bar, see that the block is made of tool steel well hardened and tempered to a straw color, otherwise an impression of the bar will be left in the block and a true Brinell will not be obtained. Small bars, 5/8 in. and less in diameter, usually give an exaggerated result lower than that obtained from the same steel in heavier bars; want of surrounding stiffness explains this. When testing malleable castings or intricate pieces, take several impressions in various places and then work out the mean result; otherwise the test may be misleading.—*American Machinist.*

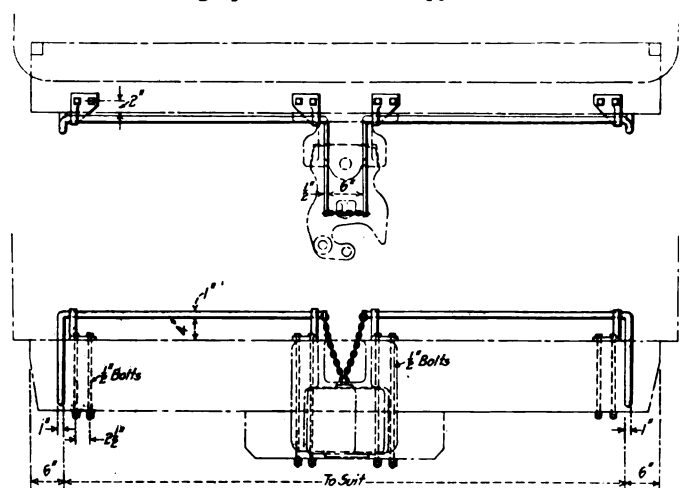

Double Uncoupling Lever for Switch Engines

design the lever is in two parts, each of which is separately connected to the lock lifter, thus making the movement of the lever at one end entirely independent of the other.

RAILWAY MEN AND THE WAR.—It is stated that 4,000 employees of the Lancashire & Yorkshire Railway are now in the British army on the continent.

PORTUGUESE EXPRESS LOCOMOTIVE

Balanced Compound Ten-Wheel Type Which Develops Exceptionally High Power Per Unit of Weight

The locomotive shown in the illustration was recently built for the Portuguese State Railways for express passenger service, and is of special interest because of the high horsepower developed in relation to the engine's total weight. A maximum indicated horsepower of 2,214 is reported to have been developed with a total weight of 165,000 lb. and a weight on drivers of 112,200 lb. This is equivalent to 1 hp. per 74.5 lb. of total weight and is nearly 40 per cent greater than the horsepower per unit of weight developed by the American Locomotive Company's experimental Pacific type locomotive, No. 50,000. The latter developed 2,216 hp. continuously in actual service, which is equivalent to 1 hp. per each 121.4 lb. of total weight. The Portuguese engine has a maximum tractive effort of 22,200 lb., while the experimental Pacific type locomotive is rated at 40,300 lb.

The Portuguese engines are built to operate on a 5 ft. 5 $\frac{3}{4}$ in gage, thus increasing the clearance limits and decreasing the difficulties of cylinder and axle design for a balanced compound locomotive. The four cylinders lie in the same horizontal plane, the high pressure being placed between the frames and the low pressure outside of the frames. The high pressure cylinders are 15.35 in. in diameter, while the low pressure have a diameter of 24.8 in., giving a cylinder ratio of 2.61. Both high and low pressure cylinders drive on the front pair of wheels, the former through a crank axle. The steam distribution is controlled by two piston valves of somewhat unusual construction. By referring to the sectional elevation of the locomotive it will be seen that each valve is made up of three heads, mounted upon the same stem, each head being surrounded by an annular cavity enclosed by packing rings at the ends. The central head, which is considerably smaller in diameter than the others, controls the steam admission to and exhaust from the high pressure cylinders. Each end of the valve serves one end of the low pressure cylinder, the annular cavities around the valve forming a portion of the final exhaust from the low pressure cylinder to the atmosphere.

Three poppet inlet valves are provided on each valve chest, and are connected with the reversing gear in such a manner that when in full forward or starting position all three valves are opened. The central valve admits steam from the high pressure steam cavity to a cored passage in the cylinder casting while the two end valves simultaneously admit the steam from this passage into the cavity below each low pressure steam port. The admission of live steam is therefore automatic, the object being to bring the low pressure cylinders immediately into service in order to quickly start the engine. This arrangement prevents the accumulation of the undue back pressure on the high pressure

piston which results from the use of the ordinary by-pass starting valve operated independently from the cab and by providing a steam passage to the low pressure cylinders which is independent of the high pressure port opening, insures a more rapid accumulation of effective pressure and a quicker starting engine than is possible with the by-pass starting valve.

The boiler is of the straight top type having a diameter of

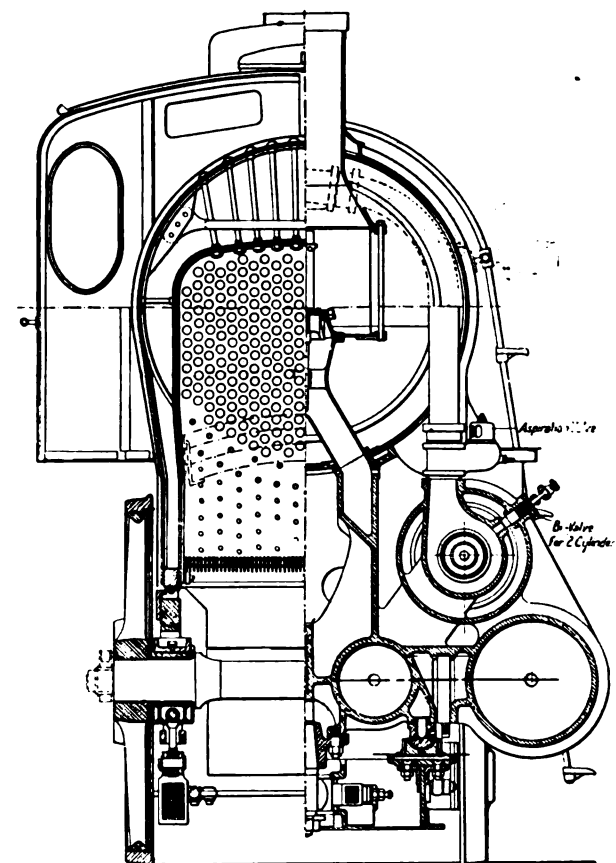

Half Sections Through Cylinders and Firebox

66 $\frac{1}{4}$ in. outside of the first ring and carrying a working pressure of 227.5 lb. It has a total heating surface of 2,503 sq. ft. of which 188 sq. ft. or about 7.5 per cent is located in the firebox. Owing to the wide gage an unusual width of firebox is possible

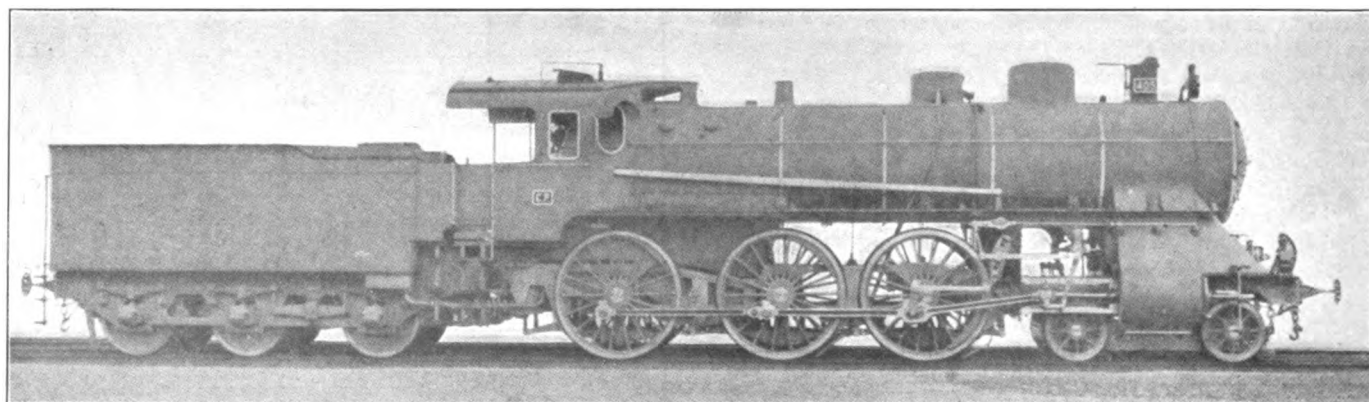

Balanced Compound Express Passenger Locomotive for the Portuguese State Railway

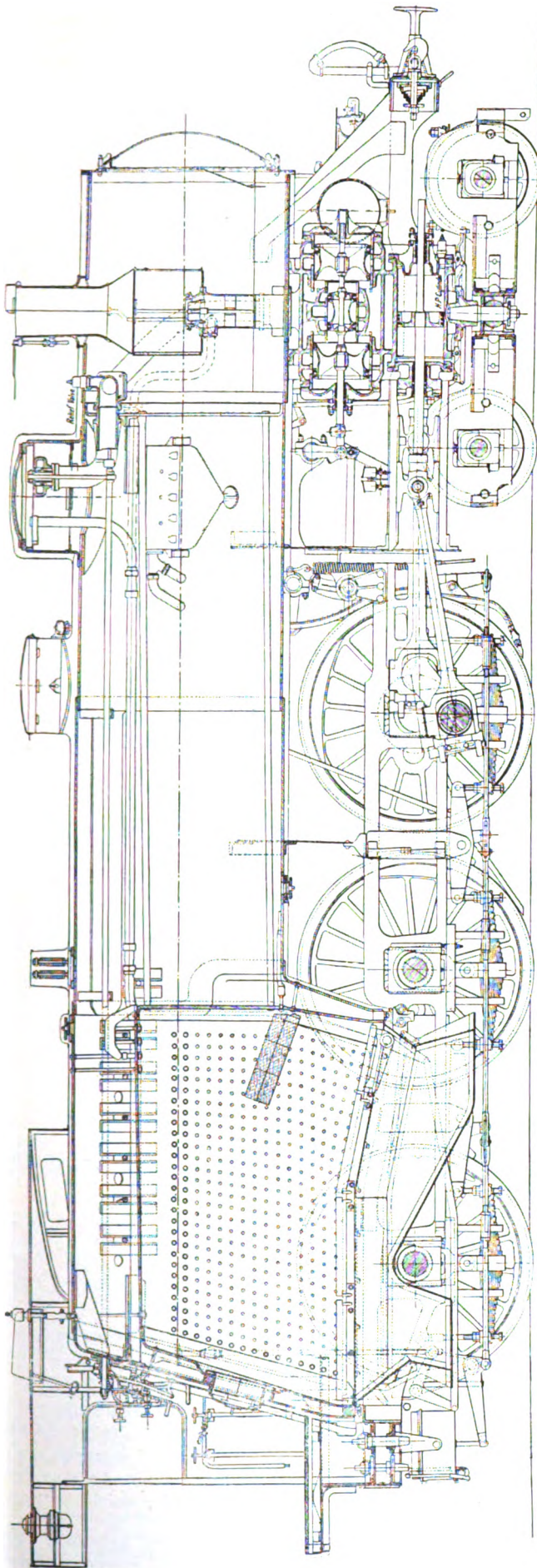

Sectional Elevation of Portuguese Passenger Locomotive

without employing a trailer truck, a grate area of 44.1 sq. ft. being obtained with a length of 123 in.

The engines have bar frames 4 in. wide with a single front rail to which the cylinder castings are secured in the manner commonly employed in American practice. All driving journals are 8 $\frac{3}{8}$ in. in diameter and 9 $\frac{1}{2}$ in. long.

In service it is said that these engines have completely fulfilled all the required conditions, their performance having proved highly satisfactory in every way. From a number of indicator cards taken in service on a level line at various speeds and cutoffs, the total indicated horsepower varies from 842 at 40 miles per hour with a train of 341 tons and a cutoff of 40 per cent to a maximum of 2,214 at 63 miles per hour while hauling a train of 388 tons and working at a cutoff of 50 per cent. The accompanying table gives the results calculated from five typical indicator cards taken under varying conditions.

HORSEPOWER CALCULATED FROM INDICATOR CARDS

Speed	Boiler pressure	Cutoff	Weight of train	I. Hp.
40 m. p. h.	213 lb.	40 per cent	341 tons	830
56 m. p. h.	213 lb.	38 per cent	341 tons	1,234
62 m. p. h.	203 lb.	35 per cent	355 tons	2,054
63 m. p. h.	227.5 lb.	50 per cent	388 tons	2,214
67 m. p. h.	227.5 lb.	40 per cent	314 tons	1,799

The tender is carried on six wheels, pedestals for which are provided in the underframe. It has a water capacity of 5,800 gal. and carries 9.8 tons of coal. The principal dimensions and ratios of the locomotive are given in the accompanying table:

General Data

Gage	5 ft. 5 $\frac{1}{4}$ in.
Service	Passenger
Fuel	Coal
Tractive effort	22,200 lb.
Weight in working order	165,000 lb.
Weight on drivers	112,200 lb.
Weight on leading truck	52,800 lb.
Weight of engine and tender in working order	270,900 lb.
Wheel base, driving	14 ft. 9 $\frac{1}{4}$ in.
Wheel base, total	29 ft. 0 $\frac{1}{2}$ in.

Ratios

Weight on drivers ÷ tractive effort	5.06
Total weight ÷ tractive effort	7.4
Tractive effort × diam. drivers ÷ heating surface	.663.8
Total heating surface ÷ grate area	56.8
Firebox heating surface ÷ tube heating surface, per cent	8.1
Weight on drivers ÷ total heating surface	44.8
Total weight ÷ total heating surface	66.0
Volume equivalent simple cylinders, cu. ft.	7.8
Total heating surface ÷ vol. equivalent simple cylinders	320.9
Grate area ÷ vol. equivalent simple cylinders	5.7

Cylinders

Kind	Balanced compound
Diameter and stroke	15.35 in. and 24.80 in. by 25.20 in.

Valves

Kind	Piston
------	--------

Wheels

Driving, diameter over tires	74.8 in.
Driving journals, main, diameter and length	8.66 in. by 9.45 in.
Driving journals, others, diameter and length	8.66 in. by 9.45 in.
Engine truck wheels, diameter	35.4 in.

Boiler

Style	Straight top
Working pressure	227.5 lb.
Outside diameter of first ring	66.2 in.
Firebox, length and width	123 in. by 51.2 in.
Tubes, number and outside diameter	300—1.87 in.
Tubes, length	15 ft. 9 in.
Heating surface, tubes	2,314.3 sq. ft.
Heating surface, firebox	188.4 sq. ft.
Heating surface, total	2,502.7 sq. ft.
Grate area	44.1 sq. ft.

Tender

Weight, loaded	105,900 lb.
Water capacity	5,800 gal.
Coal capacity	8.8 tons

GERMAN IRON ORE PRODUCTION.—Germany's iron ore production for 1913 is given by Stahl und Eisen as 35,941,285 metric tons, having a value of 3.71 marks (88.2 cents) per ton as compared with 33,711,142 tons in 1912 with a value of 3.73 marks (88.7 cents) per ton. In 1913 48,047 miners were working as against 46,295 in 1912. Brown iron ore containing less than 12 per cent of manganese constituted 3,005,970 tons of the 1913 total, while the brown ore containing from 12 to 30 per cent manganese amounted to 330,037 tons. Manganese ore of over 30 per cent manganese totaled 760 tons in 1913.—Iron Age.

ECONOMIC VALUE OF A LOCOMOTIVE*

Earning Capacity Analyzed; Opportunities for Increased Returns; Improved Shop Methods Prove Economical

BY GEORGE S. GOODWIN

Mechanical Engineer, Chicago, Rock Island & Pacific, Chicago, Ill.

Consideration of the potential value of locomotives, expressed even roughly in terms of average daily earning capacity, suggests several important possibilities for the improvement of general practice, which it is the purpose of this paper to discuss. For the fiscal year ending June 30, 1913, the total operating revenue from 251,277 miles of railroad was \$3,181,177,898, divided as follows:

Freight	\$2,203,860,284....	69.28 per cent
Passenger	716,174,021....	22.51 per cent
Other transportation revenue.....	224,939,393....	7.07 per cent
Total revenue from transportation.....	\$3,144,973,698....	98.86 per cent
Non-transportation revenue	36,204,200....	1.14 per cent

Total revenue from transportation.....\$3,144,973,698....98.86 per cent

This revenue was produced by the use of 63,198 locomotives having an average tractive effort slightly over 30,000 lb. Assuming that 11 per cent of these locomotives are in the shop receiving repairs, this leaves 56,246 earning the above revenue. Dividing the total revenue from transportation, by the number of engines gives nearly \$56,000 per year, or \$153 per day as the gross earnings of an engine. Applying to this figure the operating ratio, 71.33, we have \$44 per day as the net earning power of all the locomotives of the United States. This money was earned after the locomotive had paid for repairing the track, paid for repairing the cars, and paid for repairing itself.

The most notable thing about these figures is that nearly 99 per cent of the total operating revenue of the railways is received from the operation of trains, for the successful operation

In order to bring out the monetary value of a locomotive a little clearer, statistics are quoted in the accompanying table from 24 of the larger roads of the middle and western states for the fiscal year ending June 30, 1913. The gross earnings of locomotives per day is the quotient of earnings divided by the number of locomotives reduced to a per diem basis. The net earnings are obtained by the use of the operating ratio. These earnings are shown under four captions, it being assumed where noted that 11 per cent of the locomotives are always in the shop undergoing repairs, and where switching engines are involved that 90 per cent only are handling freight.

These figures bring out that the net average earning power of a locomotive varies from \$30 to \$125 per day; while for all the roads of the United States the earning power is \$44. The average rate per net ton mile is introduced to show one reason why the value of a locomotive fluctuates—a locomotive capable of earning \$75 per day on one road may be able to earn only \$40 per day on some other road, and this is further affected by the size of the engine, amount of work for it to do, etc.

The value placed on a locomotive when rented of course varies on different roads, both as to amount and basis of computing. (Invariably running repairs are taken care of by the borrower, and general repairs by the lender.) Some use the size of cylinder, others the weight on drivers or total tractive effort. The general minimum charge is \$10 per day, increasing to from \$25 to \$40 for the modern engine. Two roads base the rental on a

Road	Mileage	Total transportation revenue	Freight revenue	Total number locomotives	Freight engines	Passenger engines	Switch and transfer engines	Gross earnings per day			Net earnings per day, freight, less 11 per cent	Operating ratio	Average revenue per T.M. — Mills
								All freight, 90 per cent, and switch	All freight, 90 per cent, and switch, less 11 per cent †	Freight, less 11 per cent †			
B	9,129	\$93,330,370	\$64,063,856	1,772	901	444	427	\$121	\$136	\$194	\$64.80	66.59	7.29
C	2,012	33,597,124	23,181,395	732	347	157	228	115	129	205	43.10	79.04	5.43
D	1,496	13,901,415	9,795,074	293	207	45	41	110	124	146	39.00	73.28	7.32
E	9,710	81,888,321	58,540,091	1,952	1,262	345	345	102	114	143	44.50	68.90	7.88
F	7,976	82,311,523	54,661,588	1,781	1,047	390	344	110	124	161	47.00	70.15	8.70
G	8,240	70,853,004	46,428,045	1,608	775	496	337	118	133	185	48.80	73.57	8.90
H	1,747	16,898,666	10,857,207	376	235	76	65	102	114	142	42.60	69.95	8.60
I	1,032	15,114,030	9,908,251	345	161	89	95	110	124	190	30.00	84.17	5.61
J	1,275	16,111,571	11,987,134	399	263	76	60	103	116	140	27.70	80.19	5.15
K	2,338	34,790,798	27,549,696	811	413	133	265	116	130	205	62.00	69.69	4.12
L	2,636	24,331,048	18,078,140	617	360	147	110	108	121	155	47.90	69.71	11.93
M	801	13,132,536	12,385,212	264	133	...	131	135	153	286	125.00	56.26	7.05
N	7,750	78,297,710	58,426,236	1,284	799	369	116	177	199	225	93.00	58.27	7.65
O	4,763	63,747,632	42,589,299	1,460	803	357	300	107	122	163	35.90	77.86	5.77
P*	1,872	57,745,398	39,376,127	980	408	212	360	147	165	297	101.00	66.14	5.33
Q*	1,819	35,019,744	23,018,013	703	348	141	214	116	131	204	60.40	70.40	6.42
R	3,817	32,104,311	20,912,978	682	404	156	122	112	126	159	46.90	70.51	11.42
S	7,285	61,671,460	45,748,269	1,153	767	230	156	138	155	183
T	2,943	20,968,555	15,330,648	313	317	161	51	177	199	227	91.90	59.47	7.05
U	1,092	10,795,233	8,155,027	216	117	61	51	177	199	227	91.90	59.47	7.05
V	6,684	71,635,298	52,270,686	1,276	736	316	224	152	171	208	80.00	61.47	8.39
W	1,885	17,886,817	12,407,401	392	230	85	77	114	128	166	30.40	81.71	9.69
X	7,569	91,810,307	63,773,804	1,465	877	380	208	164	185	224	101.00	55.08	9.27
Y	2,515	31,486,479	21,774,362	697	422	133	142	109	122	159	35.40	77.73	5.85

* Lines East of Chicago.

† Where noted, 11 per cent of the engines are assured to be in the shop; 90 per cent of switch engines are assured to be engaged in freight service; 10 per cent passenger.

of which three essentials are necessary, namely: Locomotives to move the trains, which is the subject of this paper; equipment to carry the tonnage, and track to move the trains on.

No two of these essentials are of any benefit without the third, and the importance of all three is shown by the fact that for the fiscal year ended June 30, 1913, \$544,000,000 was spent for maintenance of equipment and \$538,000,000 for maintenance of way.

* Abstract of paper presented before the Western Railway Club, February 16, 1915.

fixed charge per 1,000 lb. tractive effort, which is about 50 cents. Five roads based their rental charges on the results obtained by calculating interest and depreciation on the value of the locomotive in question. To this is added charges for general repairs, taxes, insurance and profit on the transaction. An example of this with the profit omitted will show what might be termed "out-of-pocket" value of a locomotive.

The following table shows approximately what this would amount to for different original cost, between \$10,000 and \$30,000

with assumed charges for interest, depreciation, taxes, etc., and repairs. In the case of repairs, these are based on the assumption that 100 miles represent a day's work for a locomotive.

RENTAL PER DAY, BASED ON INTEREST, DEPRECIATION, TAXES, INSURANCE AND REPAIRS

Original cost	Interest at 5 per cent	Depreciation at 5 per cent	Taxes and insurance at \$1.09 per \$100	Repairs, basis 100 miles per day	Total
\$10,000	\$1.37	\$1.37	\$0.30	\$7.00	\$10.04
15,000	2.06	2.06	.45	8.00	12.57
20,000	2.74	2.74	.60	9.00	15.08
25,000	3.43	3.43	.75	10.00	17.61
30,000	4.11	4.11	.90	11.00	20.12

Of the four methods used, namely, size of cylinder, weight of drivers, rate per 1,000 lb. tractive effort and interest and depreciation, the last two are more accurate, and the third is more attractive from the standpoint of simplicity. One must admit, however, that the last discriminates between the modern, highly efficient engine and the old engine which is less efficient. The modern engine with the latest devices to give more economical performance certainly is worth more than the same size engine built ten or even five years ago.

We have thus developed three measures of the value of a locomotive: What it can actually earn; what it is worth from an investment standpoint, or what might be termed the "out-of-pocket" value, and what it is usually rented for. We have also shown that 99 per cent of the total operating revenue is produced by these locomotives while moving trains.

An engine earns money only while it is moving freight, and is unproductive when not working. In order to bring out forcibly the actual miles an engine makes per day, data have been taken from the reports of the Interstate Commerce Commission for 24 roads, which shows an average of 57 miles per day or 4 hours at 14 m. p. h. for freight locomotives. On the road with which I am connected a study has been made of just how a freight locomotive day is spent and a form of report* has been developed under the direction of N. D. Ballentine, assistant to the second vice-president, which accounts for every movement of the locomotive during the day. Reports are made independently by the roundhouse foreman, yardmaster and train conductor and these are combined with the information regarding engines in the shop into a single report which is summarized for the month something as below. (In comparing this data with other lines great care should be taken to know on just what basis their data is prepared, and unless the information is developed from a record to that described above, its accuracy may be open to serious question.)

FREIGHT LOCOMOTIVES—MECHANICAL DEPARTMENT CARE			
	Hours	Minutes	
Roundhouse	6	49	28.40 per cent
Running repairs	2	41	11.18 per cent
Classified repairs	3	27	14.38 per cent
Total mechanical department	12	57	53.96 per cent

TERMINAL DETENTION			
	Hours	Minutes	
Regular schedule	2	55	
Stock, fruit, vegetables	0	7	
Superior trains	0	3	
Insufficient tonnage	0	20	
Main line obstruction	
Rest for crews	0	7	
Miscellaneous	0	14	
Time between call and departure	0	16	
Total terminal detention	4	2	16.80 per cent

TIME BETWEEN TERMINALS			
	Hours	Minutes	
Actual running time	4	16	17.78 per cent
Meeting trains	0	53	(Miles per day 68)
Station work	1	20	
Track conditions	0	1	
Sixteen hour law	0	1	
Accidents, etc.	0	1	
Block signals	0	2	
Engine failures	0	2	
Car failures	0	3	
Weather conditions	
Miscellaneous	0	22	
Total time between terminals	7	1	29.24 per cent
Total time accounted for	24	0	100.00 per cent

*See Railway Age Gazette, October 27, 1911, and October 25, 1912, for descriptions of these reports.

This brings out clearly the following points:

	Hours	Minutes	
An engine is in the hands of the mechanical department being made ready to move tonnage	12	57	53.9 per cent
An engine is in the hands of the transportation department ready to move tonnage	6	47	28.3 per cent
An engine is actually moving tonnage and therefore earning money, only	4	16	17.8 per cent

This brings us to the third division of this paper, viz., What can be done to make the engine more available for handling tonnage? This same thought is very aptly stated by George R. Henderson quoted in Baldwin Record of Recent Construction, No. 60. Mr. Henderson stated as follows:

"The author believes in wearing out locomotives as fast as possible. By this he does not mean wearing them out by improper treatment or careless maintenance, but by the legitimate work of hauling trains. The faster they can be worn out the sooner they will be replaced with modern machines, and the strides made in the power and type of locomotives in the last few years have been such that an engine only 10 years old is of comparatively little use, except for branch service."

In the example of the distribution of a locomotive day, the roundhouse is charged with 6 hours and 49 minutes or 28.4 per cent of the day.

This time is taken up in turning the engine. There are several items in connection with this work in the roundhouse which will suggest opportunities to reduce the time. Improved dump grates, good ash pan designs, properly maintained turntables, and hot water boiler washing systems are all vital factors in reducing the time in the roundhouse. Good inspection is necessary in order to save failures on the road. Inspection pits have been found to be advantageous, especially when engines are to be turned quickly and have not time to be placed on the roundhouse pit. There should be enough men in the roundhouse to do the work needed and the facilities should include a small machine shop adjacent to the roundhouse, equipped with drill press, shaper, lathe, bolt cutter and emery wheel, also a small, well-equipped tool room. This machine shop saves a lot of time running back and forth to the big shop. There ought also to be good air and steam pressure.

Running repairs is charged with 2 hours, 41 minutes, or 11.2 per cent of the day. Running repairs no doubt vary closely with the time an engine has been out of shop, and with the thought in mind of reducing the running repairs the road with which I am connected has reduced the mileage between shoppings. There have also been put into effect some changes in detail design, which in many cases eliminate entirely the running repairs. For instance, we cast a brass hub liner on the face of the driving box. The result is that it is unnecessary to drop the wheels between general repairs, and there is saved the cost of this work, which conservatively is \$25 for labor and material, and the engine out of service for three days, which at \$44 per day is \$132. A lesser saving as regards running repairs is made by the use of brass shoe and wedge liners on the driving box. The good effect of these shows most clearly during general repairs. We find them with the tool marks hardly worn out and it is therefore unnecessary to line up the shoe and wedge.

Another source of trouble is the pounding of the main driving boxes with its attendant trouble in the rod brasses. This means the dropping of the wheels to repair the brasses. It would seem that this work could be minimized by the use of some form of removable brass, although we have no experience with these devices; we have, however, used the so-called long driving box with the result that the trouble was entirely eliminated, and in addition there is less wear of the axle. The cost to drop a pair of wheels and to crown the brass is approximately \$23 labor and the engine is out of service three days.

To minimize stay bolt trouble the practice of using the same form of flexible stay throughout the breaking zone is a great aid. One of our boiler foremen estimated this alone to save one or two days every 60-day period.

With the advent of the gas and electric welding outfits it has

been possible to make many repairs that heretofore would not have been possible. For instance, we had a Mikado engine with all driving wheels having flat spots 2 to 5 in. long and $\frac{1}{8}$ to $\frac{1}{4}$ in. deep. To have dropped the wheels would have cost not less than \$150, which includes the loss in tire material. To this must be added the value of the engine while out of service for three or four days. We welded the flat spots with an electric torch, the wheels being in place under the engine, in five hours at a cost of \$2.05 for labor and \$5 for material and current. Both the gas and electric torch have been used successfully in this work. This is only a single example of what this device offers in the way of getting an engine into service promptly and at the same time at a greatly reduced cost of repairs. It should be an easy matter on the above showing alone for any railroad to justify the purchase of these outfits. Forty-four dollars saved for an engine day is interest at 5 per cent on \$880 per annum, or by saving 20 engines one day you save \$880.

After the engine has made its mileage it, of course, gets a general overhauling, and whenever possible we make our engine candidates for shop pull a train to the point of shopping. If it be assumed that an engine receives general repairs every 18 months and that 60 days is the average time from out of service to in service, that means that 11 per cent of the engines are always in the shop. Sixty days multiplied by \$44 equals \$2,640, the loss while the engine is at the shop. During slack business when locomotives are not needed to move trains, it is obvious that we should put them through the shop to the extent that they are ready for the shop and that the shop can take care of them.

While it is desirable to have a few engines in the "bone yard," so that "lights" and "heavies" can be properly balanced, there can be a saving made by not having too many engines standing around idle waiting to get into the shop, but rather schedule their movement to the shop so that they are available with the least waste of engine time. An ideal condition would be more nearly realized when the condition of the engines slated to go to the shop were such that one or two months in service, if necessary to suit the convenience of the shop, would not mean a series of failures.

When an engine is about to go to the shop, many roads (ours among them) make a practice of sending advance notice to the shop of just what material will be needed. On firebox work 30 days advance notice is desirable, so that the box will be ready to put in as soon as the old box can be cut out. To make the most of this plan of advance notice, the information must be accurate and be acted upon promptly, without waiting to get the engine in the yard to see if the material is *really* needed.

After the engine reaches the shop what improvements can be made there with a view to cutting down the time in the shop? The first thought is modern shop facilities, and, considering that an engine is worth \$44 per day, it ought not to be difficult for any one to show substantial savings by the use of more modern shops. Assume a shop turning out 30 engines a month, or 360 per year, and that by making certain changes an engine could be turned out four days sooner. Assume further that for three months of the year there is sufficient business to provide work for these engines just as soon as they are turned out. The saving then will be 90 engines multiplied by four days, or 360 engine days, which at \$44 per day equals \$15,840. Now, if we had taken this \$16,000 and purchased an engine with it, we would have had the same amount of available power, since by changing the shop we saved 360 engine days; but the more modern shop will enable repairs to be made more cheaply, and, further, the capacity of the shop is increased 6.7 per cent. Hence, it would be considerably more economical to modernize the shop. Of course, if this improvement can be made at less than the above the saving is increased proportionately.

Another item which I understand some roads have to contend with is material. An engine is delayed for want of proper repair material, and this delay in some cases runs into months. It must not be understood that this is entirely the fault of the stores department, as many times the material was not ordered as promptly

as it might have been. On the other hand, the shop man has a perfect right to assume that certain kinds of material are kept in stock continuously by the stores. A great deal of this material for which engines are delayed is very moderate in price, so that no great valuation is involved, and, further, practically all material is common to several engines, particularly where there are a number of engines in a class, and this reduces the amount of stock necessary to carry in order to adequately protect the engines against delay. Too often the fact seems to be lost sight of that an engine is worth money, and the fact only is seen that there is so much money invested in stock, without regard to whether the equipment can be repaired promptly. This policy cannot be too strongly condemned, since both the mechanical and stores departments are working to the same end, i. e., to keep the engines in condition to earn revenue for the railroad.

DISCUSSION

M. K. Barnum, superintendent of motive power, Baltimore & Ohio, stated that the average number of miles of the locomotive per day and the time in service is surprisingly low, and blamed the conditions under which it is necessary to operate some trains for this low figure. Regarding terminal detention he stated that on the Baltimore & Ohio one division has decreased this delay from three hours to one hour by a careful study, with no cost to the road. One cause of excessive terminal detention is the lack of proper facilities for turning heavy power. These should be provided before such engines are purchased.

H. T. Bentley, superintendent of motive power, Chicago & North Western, stated that enough men should be held in the roundhouse to make running repairs properly when necessary, and not have any more than necessary when engines are not being repaired. He has found it desirable to keep one or two engines in the back shop for comparatively heavy repairs in order to keep men busy all of the time. These repairs will, of course, be more costly but the availability of the men will make it worth while. He did not believe in reducing the mileage between shoppings. His road has kept engines in service by use of special devices on the engines, some such engines having made over 200,000 miles. Engines which a few years ago used to make 4,000 miles per engine failure have made as high as 44,000 miles per failure during the past year. This result is attributed to the special efforts of the roundhouse and shop men together with the use of improved details and special devices on the locomotives.

A. R. Kipp, mechanical superintendent, Soo Line, stated that on regularly assigned engines the mileage is limited by the rest of the engine crews or the 16-hour law. He pointed out that the interest and depreciation of the extra locomotives required for regular crews must be considered together with the claimed decrease in maintenance and productive costs and operating expenses.

N. D. Ballantine, assistant to second vice-president, Rock Island Lines, suggested that the same system as was described in the paper be used on roads maintaining the regular crew system in an endeavor to find out just what the value of a locomotive is under that system.

Mr. Goodwin said that with the value of the freight engine in excess of \$44 per day the advantages of regular crewed engines should be carefully studied. It might be found advisable to pool the engines in rush season and assign them when there were plenty of engines available.

VALUE OF NEATNESS.—We had occasion to go into a shop a short time ago where the virtue of neatness was instilled in a novel manner into the minds of the boys employed. One of the first things a boy is asked and shown how to do is to wrap up parcels. The head of this company believes that if a boy can be trained to properly wrap up objects of awkward shape, one of the cardinal qualities of a useful employee—neatness—is being fostered.—*American Machinist*.

CAR DEPARTMENT

THE STANDARD BOX CAR—A NEGATIVE VIEWPOINT

BY R. W. BURNETT

General Master Car Builder, Canadian Pacific, Montreal, Que.

From time to time we read stirring articles from high railway officers on the desirability of a standard box car; these frequently take the form of a demand, a call to arms to rise and overthrow the mechanical man who, it would seem from these articles, has for many years obstructed progress and caused untold millions of expense by a failure to attain the desired end. Such articles are usually favorably commented on in the railway magazines, the impression seeming to be that the writers must of necessity be right, and the weakness of the mechanical man is sometimes apologized for with suggestions that in time he may come to see the matter in the same broad way as the higher officer.

If the box car situation is analyzed it will be found that the traffic officers and the officers who control the policies of the railroads are responsible for the diversity of box car dimensions, and that no one would be more pleased than the mechanical man if a more limited number of designs were decided on. Cars of varying or unusual dimensions, such as those of more than usual length, height or width of side door, or having large end doors or otherwise fitted for special service or use in a restricted territory; or for service which may be peculiar to the entire territory reached by the home road, are being demanded by the traffic department. It is not for the mechanical man to say that these cars, which may make 90 per cent of their mileage on the home road shall be built to the standard dimensions said by the traffic department to be unsuitable for the home service, in order that the cars may be standard for the 10 per cent of their mileage which may be made on foreign lines.

These matters can only be settled by the traffic department and others who decide on matters of policy affecting almost exclusively their own department. If persons who are at all worried about the box car situation will take the trouble to investigate, they will find that the box cars built in the last few years, especially those with steel superstructure, are costing very little for repairs. Barring wrecks, the repairs are confined almost exclusively to couplers, wheels, trucks and other parts which are all standard. If any large part of these repairs is due to a weakness in the standard the doctrine of adopting a standard box car is then proved unsound, as the standards were usually amply strong to meet the demands of service of the period for which they were designed; if weak, the design has been outgrown in the rapid development of the railways, which is the case with the car itself and which to some extent will be the case with any car that might be adopted at this or any other time.

From the large percentage of steel frame box cars built during the last few years the indications are that this design will be very largely used in the future. These cars are largely constructed of rolled shapes which seldom need renewal, even when a car is wrecked, as they can easily be straightened or reformed to the original shape at any car repair point. It has been found unnecessary to carry rolled shapes in stock for repairs, and as the parts of the cars which fail are the parts which are already standard, it is only necessary to carry in stock lining and decking, which are being standardized. The cars which are giving trouble now, and which are largely causing the uneasiness that brings forth the letters and articles referred to, are the cars which were built from ten to twenty years ago and represent the best state of the art at that time. If the best of

them had been adopted as standard and had so continued to the present day, there is no doubt that the present repair bills would be about double what they are, and this to a degree is what it would mean in the way of expense ten or twenty years hence should a standard box car be adopted now.

It is true that we sometimes see appliances on cars, the value of which may be very much questioned, but it is probable that the net result of the use of these questionable devices may be on the credit side of the ledger for the railroads as a whole, as they are for the most part being developed towards some desired end with the final result that a simple and effective device is secured. It is also true that occasionally a designer makes an unfortunate mistake in some vital part of the car which results in bad failures on a certain series of cars, but these cars are usually so thoroughly advertised by the embargo placed on them by other roads that the railroads are benefited as a result, because the same mistake is not likely to be repeated.

If a box car with wooden underframe and superstructure were to be continued it would probably be advisable to go very much more into the standardizing of the parts than has been done, as the wooden car differs from the steel car in that the amount of material carried for repairs increases with the life of the car, whereas the corresponding parts do not have to be carried at all for steel underframe and steel superstructure cars, since more than enough parts are saved from fires and cars demolished in the wrecks to take care of the few renewals that are required. At the Angus shops of the Canadian Pacific, where we have been ordering small lots of 250 box cars at a time to keep the shop going in a small way during the depression, every lot of cars is built slightly different; this in no way affects the desired interchangeability and will reduce the cost of maintenance. These changes are made principally for the following reasons: To protect the lading from the elements; to increase the strength; to reduce the weight, and to reduce the cost of maintenance. Examples are given below of how the conclusions are arrived at governing the changes for the four reasons given above.

Protecting the Lading from the Elements.—We have a sprinkler arranged to test a sufficient number of cars coming out of the shops to determine any possibility of leakage through the roofs, sides and ends. This is not the impractical fire hose test, but is made to approximate the worst storm conditions, and we do not stop when any weakness is found until we find a substantial way of remedying the trouble. This is not usually done by car builders and is obviously much better than waiting for the claims department to report trouble, and the writer considers it unfair for shippers to be forced to use a car designed in all small details by persons who have not had the opportunity to make all of these investigations.

To Increase the Strength.—Minimum weight being a very important factor in the designing and building of cars in the effort to reduce weight, we occasionally turn out a finished design that may require slight strengthening in some of the parts. The necessity of increasing strength is usually confined to the superstructure as we have from experience largely overcome the weaknesses that were common to the underframe.

To Reduce Weight.—While not so necessary as increasing strength, yet it is important to reduce weight where it is possible to do so with safety. Many opportunities are afforded with the variety of rolled shapes that is available, to accomplish this without any additional cost, and often with a reduction in cost.

To Reduce Cost of Maintenance.—While the cost of mainte-

nance is carefully considered by the designer, yet the cars in actual service when carefully observed bring to notice certain items of expense that can be remedied, and in some cases entirely eliminated. The use of rivets in place of bolts is probably one of the most important items to be considered in repair work. Bolts were used in the past for securing parts that would require frequent renewals, but as the failures to these parts have been reduced the bolt, which is expensive in maintenance, has been replaced by the rivet. The use of cast steel and pressed shapes in place of malleable iron have also to be considered here.

The comparatively low average cost of maintenance of the present day, considering the large amount of old wooden equipment still in service, is entirely due to the present design of car which confines the repair expense almost exclusively to the wearing parts, outside of a few unfortunate mistakes in design, as previously mentioned. It must also be borne in mind that the car of the present cannot show the lowest cost of repairs, while relieving the high cost of repairs to the old wooden car which is still with us.

To sum the matter up, the parts that are movable and need to be renewed should be and are standardized. The use of rolled sections gives us a car which is otherwise a car of standard parts. We also have minimum requirements for the center sill construction which would seem, for the reasons given above, to be about as far as we should go at present in standardizing the box car, except that limiting outside and inside dimensions should be arranged for; this should be attended to by the traffic department. One of these dimensions, the height of running boards, it would seem very essential to decide on in order that the roads will not keep on increasing the height of their cars until the government concludes that there is not sufficient room for the trainmen on top of the cars and issues an order that bridges, tunnels and overhead electrical construction must be raised to give sufficient clearance, which would be very expensive.

As small changes in the development of the car do not increase the amount of material to be carried in stock, or the cost of maintenance, why should a complete standard car be adopted, which, if followed, will shut off the improvement of details which is necessary if we are to progress?

PIECE WORK AND ITS ADVANTAGES*

BY E. J. THILL

Piece Work Foreman, New York Central, East Buffalo, N. Y.

The greater part of my railroad career has been spent in connection with piece work, and needless to say, I have had my troubles, due mainly to men who are averse to the use of the system.

I believe we will all have to acknowledge that the tendency of the day work system is to bring the superior workman down to the level of the inferior. This is virtually placing a premium on inefficiency and therefore is opposed to the accomplishment of the desired results. On some of the western railroads there is a system in operation known as the bonus system, whereby a workman receives a bonus in addition to his daily rate of pay. This bonus, I understand, consists of a part of the increase earned by the operator by reason of an increased output, due to increased efficiency and diligence on his part. While this system may give better results and bring better returns to the men than the day work system, it does not seem possible that it will provide maximum output per operator, minimum cost per article, and maximum earning rate per hour, per operator, such as would be attained under a proper piece work system.

There are three potent factors in the successful handling of

a piece work system. These are efficient piece work inspectors, peace of mind on the part of the workmen, and a schedule that can be readily understood by the men.

Peace of mind on the part of the workman is absolutely necessary if he is to do his best under any system. This should be considered in the light of the fact that the piece work operator is often suspicious of the piece work inspector. If there is one thing that will put a piece work operator out of sorts, it is the slightest doubt as to whether he has received proper reimbursement for his labor; therefore a great deal depends on the piece work inspector, as the average workman is no mathematician, and generally has an innate suspicion of the inspector, in that he is not reasonably sure that he has received proper returns for the work performed. For this reason the piece work schedule should be one that can be easily interpreted and understood, and combination prices eliminated. The other two factors in an efficient piece work system rest with the management, and make it possible for the success of the one just described.

Extreme care should be exercised by piece work inspectors to see that the men are fully compensated for the work performed, and in the matter of piece work prices, to see that the workman is properly compensated, considering the conditions under which he is working, and that the company obtains the desired results. A piece work price should not be installed where the inspector cannot "back it up." In other words, he should never set a price under given conditions unless he can produce men from the working force who can demonstrate that the price is right and good for an increase of about 50 per cent or more over the day rate. Then, should a workman question the fairness of the price, he can be shown that it is productive of increased earning capacity, and he will readily see that piece work is of great benefit to him and the piece work inspector is his friend. These are the results obtained under a proper piece work system and are conditions that appeal strongly to the operator.

Did you ever stop to consider what little importance you are alone; how little you would amount to if it were not for the association and co-operation of others? What would the tools and machinery of an institution or shop amount to if it were not for the men who operate them? In this sense a piece work inspector should take the operator into his confidence and show him that he believes in him; show him how his earning capacity can be increased and how both he and the railroad company can be benefited, then you will derive from the workman the full benefits resulting from the use of a piece work system.

Every man working in a shop under a proper piece work system knows that it is wise to study at all times ways to get his work out quicker, as he realizes he will be benefited thereby. He is aware that the shop superintendent and his foreman are anxious to co-operate with him along these lines, and that he will not be penalized for using his brains in having the piece work price cut, because by his increased output he is decreasing the cost of production. In my estimation, piece work can never be handled successfully if the management will allow the prices to be cut as soon as they become remunerative to the workmen. Nothing is more discouraging to a man than this price cutting for no other reason than increased efficiency on the part of the operator. Therefore it behooves the piece work inspector when making prices to use the utmost care to note the conditions under which the man is working. In this connection, I wish to bring out that where men are put on piece work, the shop equipment should be of such design and quality as will offer best results and should be kept up at all times.

In closing, I desire to emphasize the fact that where a shop is working under a thorough piece work system, there is no question about its efficiency, as I believe piece work may properly be considered a synonym for efficiency.

*From a paper read before the Niagara Frontier Car Men's Association, February 17, 1915.

STEEL BAGGAGE AND MAIL CARS

New Equipment for the Central of New Jersey Is
70 ft. Long and Has a 30 ft. Mail Compartment

The Central Railroad of New Jersey has in service seven steel baggage and mail cars having a 30 ft. mail compartment equipped according to the United States Government specifications and a 40 ft. compartment for the transportation of baggage or express.

The web plates are 5/16 in. thick, and each has two 3½ in. by 3½ in. by ½ in. angles riveted to it, top and bottom, while riveted to the flanges of the four top angles is a 2 ft. 5 in. by ½ in. top cover plate. This plate is 65 ft. 3¼ in. long, and does

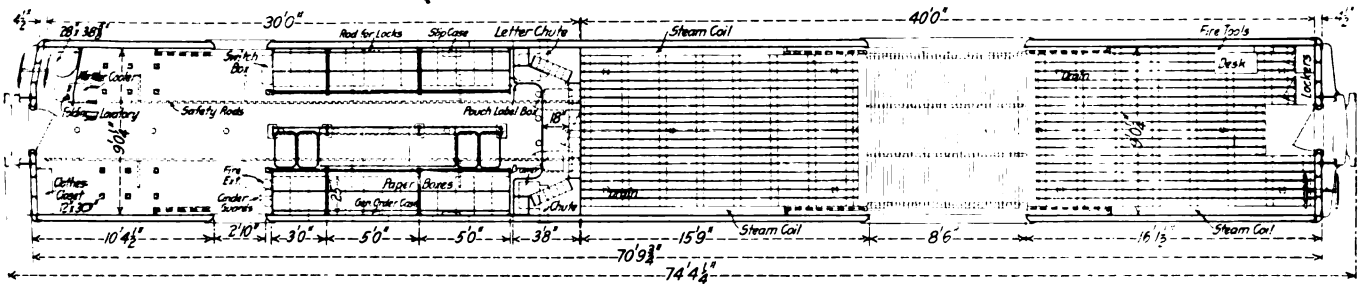

Floor Plan of the Jersey Central Baggage and Mail Cars

These cars were built by the Harlan & Hollingsworth Corporation, Wilmington, Del., are 70 ft. 9¾ in. long over end plates and weigh 144,700 lb. each. They are mounted on six-wheel trucks equipped with the Commonwealth steel frame, and clasp brakes.

not therefore extend the full length of the car. A bottom cover plate is not used.

The two center crossbearers are placed 5 ft. 4 in. on either side of the center of the car, and are built up of diaphragms

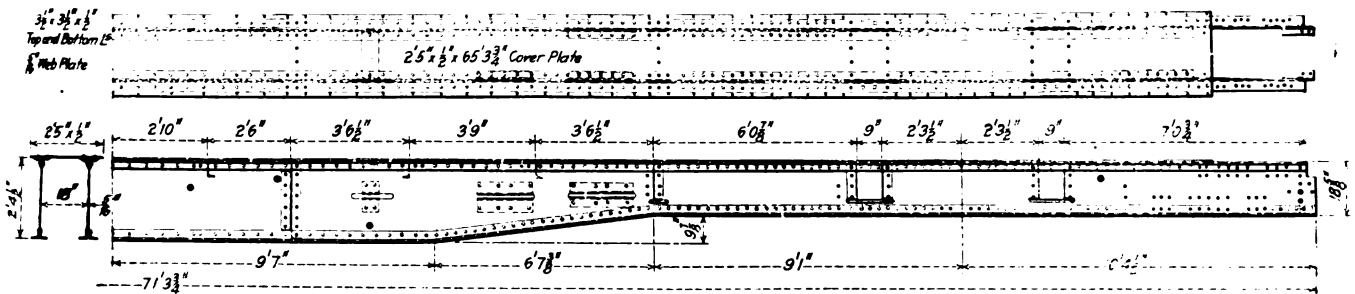

Center Sill Construction of the Baggage and Mail Cars

UNDERFRAMES

The center girder, which is the main member of the underframe, is of the fishbelly type, built up of steel plates and angles. The two web plates are 2 ft. 4 in. deep at the center of the car,

pressed from 5/16 in. plate, which are the full depth of the center sills at the inner end, while the lower flange tapers upward toward the outside of the car till a depth of 6¼ in. is reached. A 5/16 in. pressed filler is also used between the webs

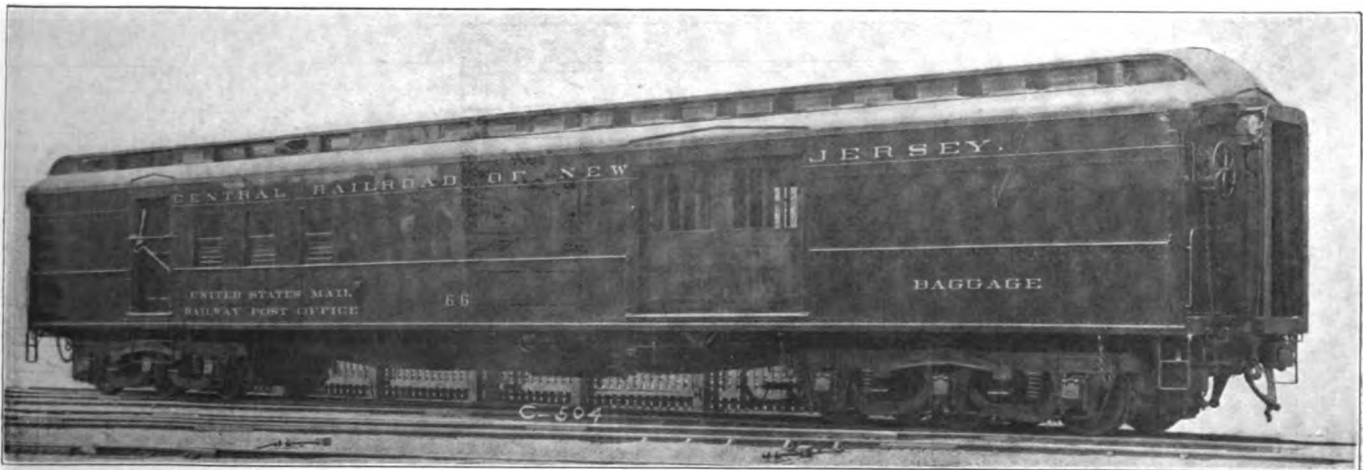

Steel Baggage and Mail Car in Service on the Central Railroad of New Jersey

and are spaced 18 in. apart; this depth is maintained for 9 ft. 7 in. on either side of the center of the car, at which point the web plates begin to taper, and at a point 6 ft. 7¾ in. farther on they reach a depth of 18¼ in., which is maintained to the end of the car.

of the center sills, and the crossbearers are finally reinforced by a 6 in. by ¾ in. cover plate at the bottom and a 9 in. by ¾ in. cover plate at the top, both extending across the car. The two intermediate crossbearers are spaced 16 ft. 2 in. on either side

of the center of the car and the diaphragms, which are 14 in. deep at the inner end and 6 1/8 in. deep at the outer end, are pressed from 5/16 in. plate with a 5/16 in. pressed filler between

The double body bolsters are spaced 50 ft. 6 3/4 in. between centers and consist of two members whose centers are 2 ft. 8 in. on either side of the center of the center plate. These members

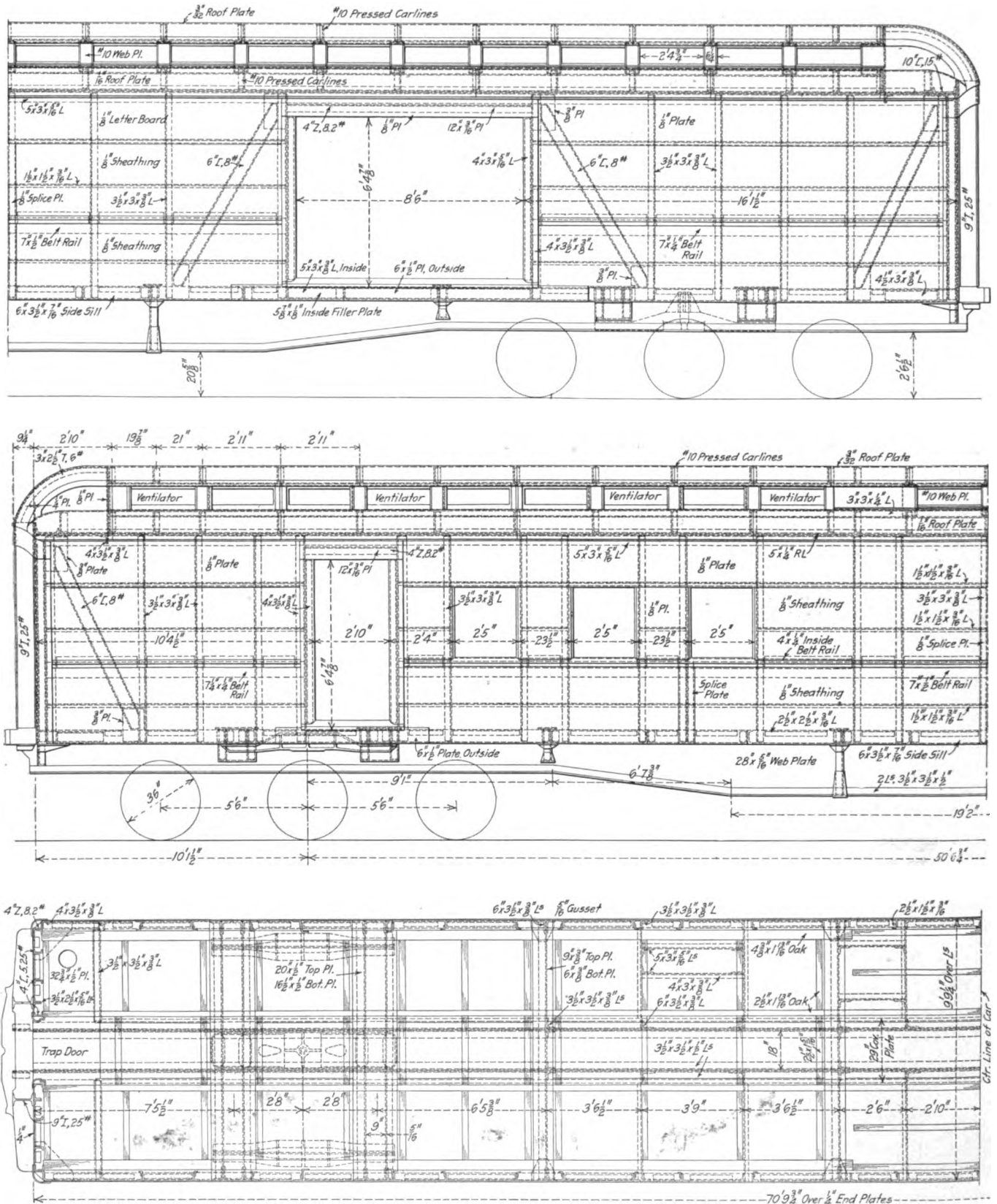

Arrangement of the Members of the Body Frame and Underframing

the webs of the center sills. A top cover plate 9 in. by 3/8 in. is used on the intermediate crossbearers as well as a 6 in. by 3/8 in. bottom cover plate, both extending the width of the car.

are built up of four diaphragms pressed from 5/16 in. plate with 5/16 in. pressed fillers between the webs of the center sills; a 20 in. by 1/2 in. top cover plate is used and a 16 1/2 in. by 1/2 in.

bottom cover plate, both extending the width of the car and riveted to the pressed diaphragms and fillers. Steel castings of special section are riveted to the two cross members of the body bolster at points 3 ft. 10 in. on either side of the longitudinal center line of the car and support the body side bearings. Cross ties or floor supports consisting of 6 in., 8 lb. channels are used, and extend between the center and side sills. The side sills are

toward the outside of the car and the back 10 1/8 in. nearer the center of the car than the inside of the web of the Z-bar, and another channel of the same size and weight is placed 12 1/4 in. nearer the center of the car with the flanges turned inward. At a distance 10 1/2 in. farther in from the back of the inside channel two 3 1/2 in. by 2 1/2 in. by 5/16 in. angles are placed with the long flanges riveted together and the short flanges turned out-

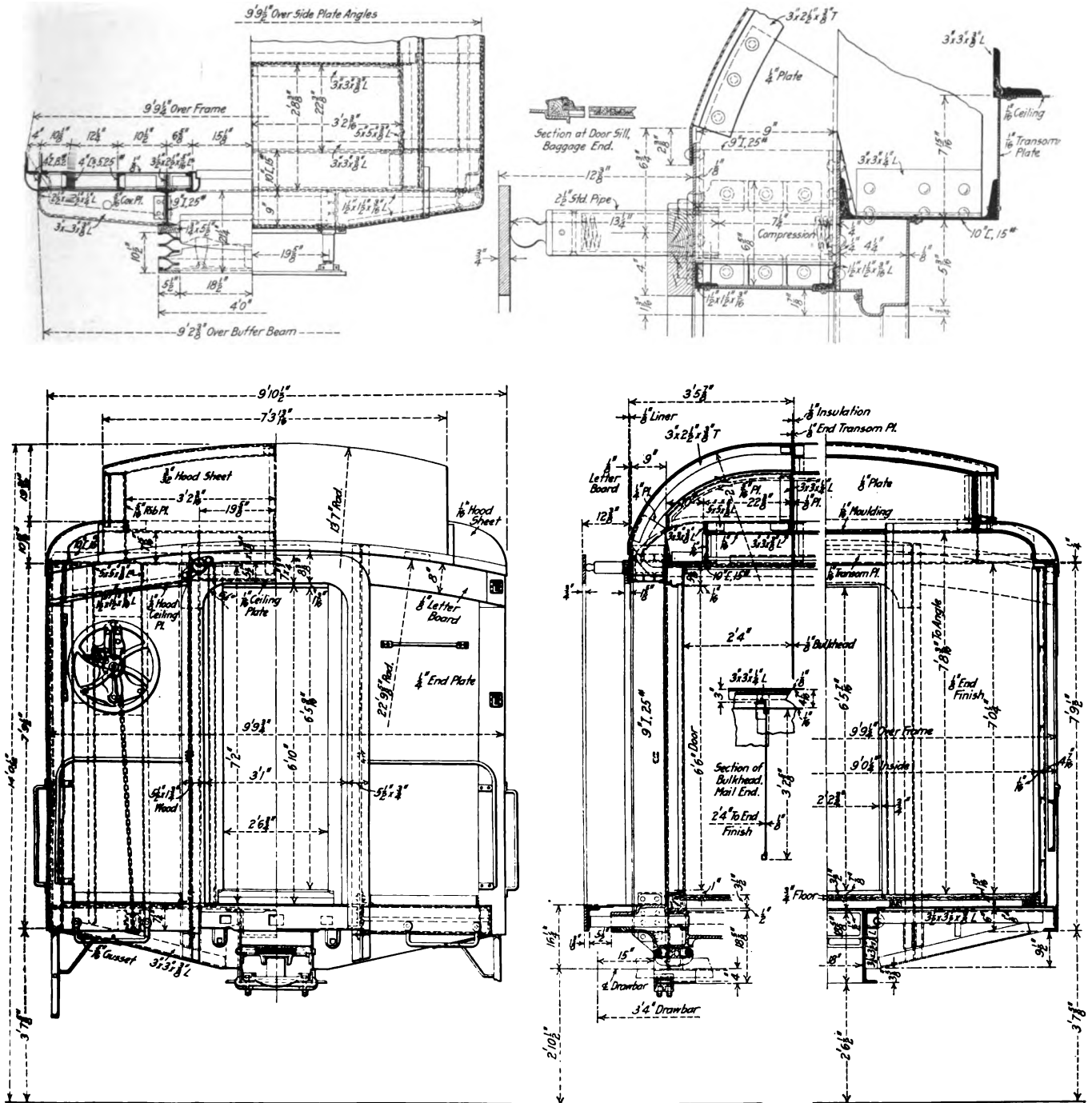

End Construction of the Steel Baggage and Mail Cars

6 in. by 3 1/2 in. by 7/16 in. angles and extend the full length of the car.

END CONSTRUCTION

The end construction is of the dummy type. The corner post of the car is a 4 in. by 3 1/2 in. by 3/8 in. angle to which is riveted a 4 in., 8.2 lb. Z-bar, and a 2 1/2 in. by 2 1/2 in. by 1/4 in. angle is also riveted to this Z-bar as shown in the drawing of the end construction. A 4 in., 5.25 lb. channel is placed with the flanges

ward at the end of the car. A 4 in., 5.25 lb. channel with the flanges toward the outside of the car and its back placed 6 5/8 in. beyond the center of these two angles forms the door post. The main vertical buffing members are 9 in., 25 lb. I-beams, and are riveted to the two connected angles referred to above. An end buffing sill construction of 3 in. by 3 in. by 3/8 in. angles and 5/16 in. plate extends between this I-beam and the corner of the car. The end members are connected at the top by a 10 in.,

15 lb. channel, extending across the car with the flanges turned upward.

BODY FRAMING

The baggage doors have an opening 8 ft. 6 in. wide by 6 ft. 2 1/4 in. in height, while the side doors in the mail end of the

posts to the corners of the car and 7 in. by 1/2 in. plate between the doors; and the side posts are 3 1/2 in. by 3 in. by 3/8 in angles; the side sheathing is 1/8 in. plate. The side door posts are 4 in. by 3 in. by 5/16 in. angles connected at the top by 4 in., 8.2 lb. Z-bars. The side plate is a 5 in. by 3 in. by 5/16 in. angle, to the

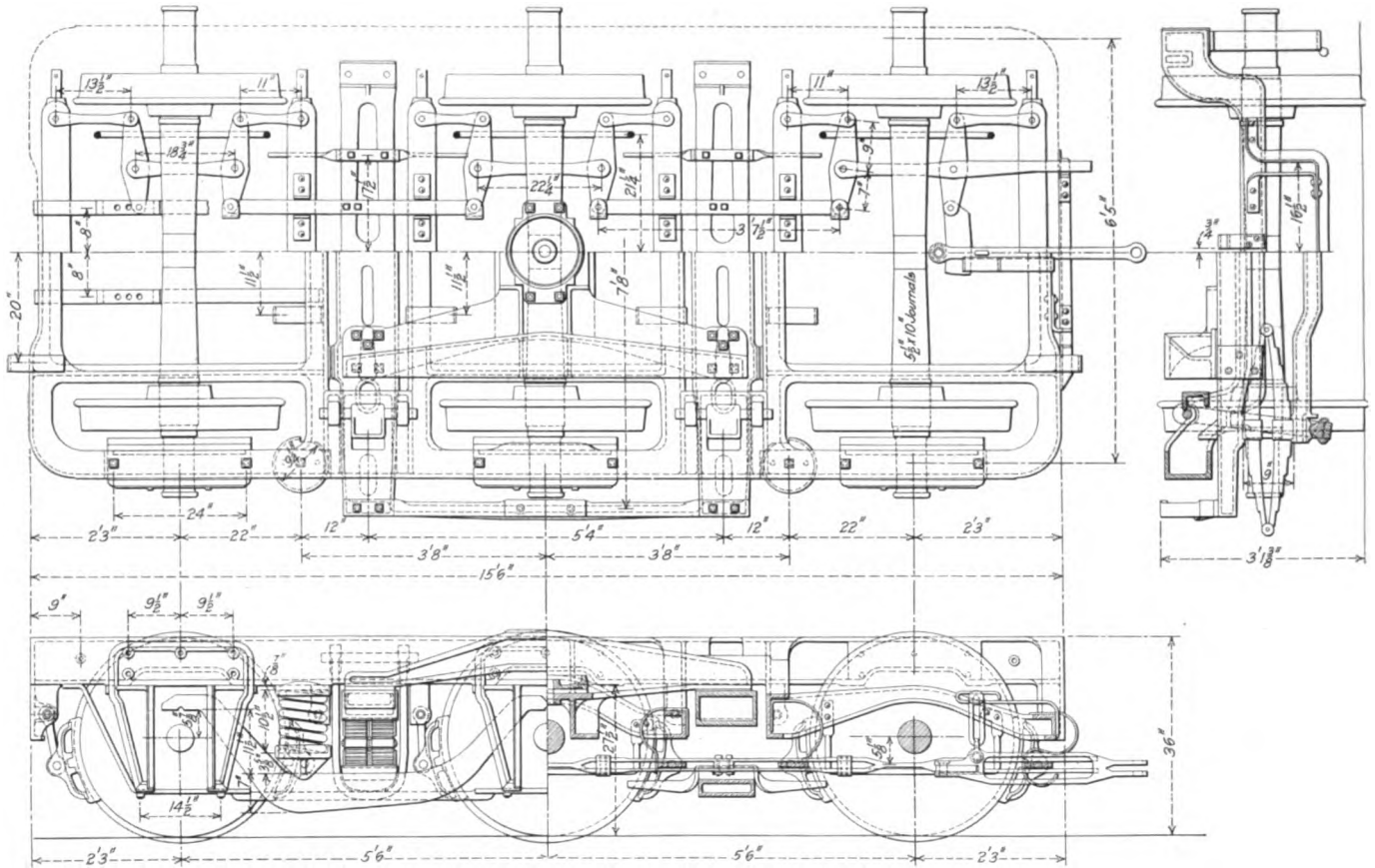

Six-Wheel Truck with Commonwealth Cast Steel Frame, Used on the Jersey Central Baggage and Mail Cars

car are 2 ft. 10 in. wide and the same height as the side doors in the baggage compartment. There are 6 in., 8 lb. channel diagonal braces used between the top of the corner posts and the bottom of the first side post on either side of the car as well as between the top of the door post and the bottom of the side posts next adjoining. The belt rail is 7 in. by 1/4 in. plate from the door

upper flange of which is riveted a 5 in. by 1/4 in. plate with a 2 1/2 in. by 2 1/2 in. by 1/4 in. angle above this. The deck sill is a 3 in. by 3 in. by 1/4 in. angle, and the carlines are pressed from No. 10 steel plate. The lower deck roof plates are 1/16 in. thick and the upper deck plates are 3/32 in. thick.

OTHER DETAILS

The trucks are of the six-wheel type, have clasp brakes and are fitted with the Commonwealth cast steel frame, which is 15 ft. 6 in. long over all. The truck wheel base is 11 ft. and the journals are 5 1/2 in. by 10 in. M. C. B. standard. The wheels are Midvale solid steel and are 36 in. in diameter.

The floor in the mail compartment is of 1/8 in. steel plate with 3-ply Salamander insulation and double wood floors, the bottom floor being 3/4 in. yellow pine, while the top floor is 3/4 in. maple, 1/16 in. insulating paper being placed between the two layers. In the baggage end the floor is of Flexolith composition laid on Keystone metal with 1/8 in. floor plates and covered with yellow pine grating. There is an oak flooring at the doorway laid cross-wise of the car. The inner side of all the outside plates throughout the car is lined with 3-ply Salamander insulation while the outer side of all the inside plates in the mail compartment is insulated with the same material, excepting the ceiling plates, which are insulated by Agasote strips between the plates and the carlines. There is no insulation on the inside finish in the baggage compartment. The mail compartment is sheathed on the inside with 1/16 in. steel plates on the sides and No. 16 gage plates on the upper ceiling. The lower ceiling is covered with No. 20 gage plate while the ends are sheathed with 1/8 in. steel plate. This is also followed in the baggage compartment.

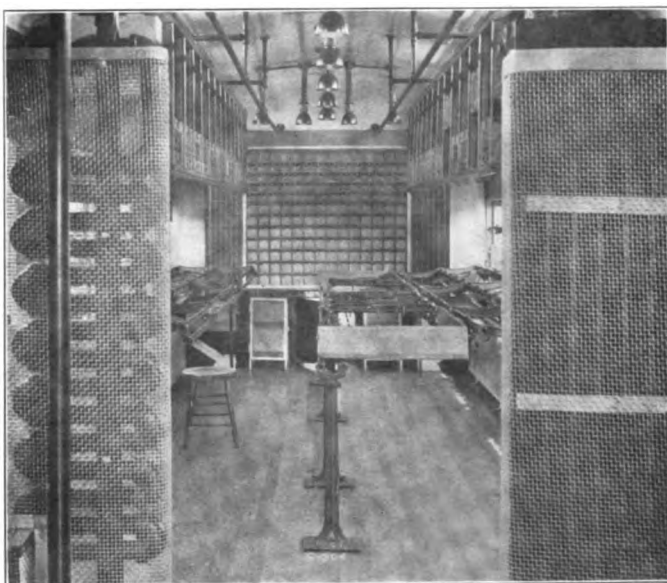

Interior of the Mail Compartment

The special equipment includes Gould couplers, centering devices and friction draft gear; Miner friction buffing gear; Ajax vestibule diaphragms; Standard Heat & Ventilation Company's vapor system of heating; Safety Car Heating & Lighting Company's axle light equipment and lighting fixtures; Edison storage batteries; Adams & Westlake Company's folding lavatory; Westinghouse air brake and signal system; American slack adjusters; Ward ventilators and Gould journal boxes.

EXPERIMENTS TO DETERMINE THE STRESSES IN TRUCK SIDE FRAMES*

BY L. E. ENDSLEY

Professor of Railway Mechanical Engineering, University of Pittsburgh, Pittsburgh, Pa.

The design of the different members of a freight car truck has received careful attention for a good many years, but so far as the writer knows, no definite information had ever been obtained with regard to the actual force coming on the side frame until the work herein described was undertaken. The object of these experiments was to obtain the actual force coming on the truck side frame and from the results thus obtained, to check tests on a truck side frame in which certain forces were assumed.

The three main forces to which the side frame is subject are, the downward spring pressure, the end thrust of the bolster, and the twisting of the side frame caused by the spring plank when the car is on a curve and the inside pair of wheels is attempting to get ahead of the outside pair. Of the three forces mentioned, the maximum direct vertical force had often been estimated and was generally considered to be not over twice the normal load on the frame when the car was standing still. That is, the vibration of the car up and down on its springs might carry the pressure underneath the spring from almost nothing to double the normal load.

The car used in the test was a Pennsylvania standard H 21 hopper, which had special cast steel trucks. One truck was designed to obtain the direct vertical load, and the other to obtain the bolster thrust and the twist of the spring plank. Special apparatus was used to determine the forces. After the car was equipped, it was first tested light, by putting it next to a switch engine in the Allegheny yards of the Pennsylvania Railroad. This was done in order that minor adjustments of the apparatus might be made and the entire arrangement tried out. After this the car was put in local and through freight trains and repeated round trips from Pittsburgh to Alliance were made. One round trip was made between Pittsburgh and Altoona in fast freight service to obtain the force due to the twisting action of the spring plank.

Table I gives the results obtained with regard to the maximum direct vertical force on the side frame.

TABLE I.—RESULTS OF TESTS TO DETERMINE MAXIMUM VERTICAL PRESSURE ON TRUCK SIDE FRAME

Test	Kind of service	Load on car, lb.	Load on truck side frame normal, lb.	Maximum pressure on side frame, lb.	Maximum load in per cent of normal
1	Local	None	8,175	16,400	200
2	Local	None	8,175	15,800	193
3	Local	66,000	24,675	52,800	214
4	Local	66,000	24,675	45,000	182
5	Through freight	91,000	30,925	66,600	216
6	Through freight	91,000	30,925	76,000	246
7	Through freight	91,000	30,925	60,000	194

The first three columns are self-explanatory. Column IV gives the load in pounds on the side frame with the car standing still. These values were obtained by subtracting the weight of the wheels, axles, side frames and journal boxes from the total weight of the car, and dividing the remainder by four. Column V gives the maximum pressure obtained with the direct vertical load. This was obtained from the record made of the maximum

compressing of the springs. The first four values in this column were obtained while the car was equipped with M. C. B. standard 100,000 lb. capacity springs, each of which has a capacity of 64,000 lb. before going solid, while the last three values were obtained with special springs, each having a capacity of 104,000 lb. before going solid. Column VI gives the total load in per cent of the normal.

Table II gives the results obtained with regard to the maximum pressure set up between the bolster and side frame, due to the end thrust of the bolster against the columns of the frame.

TABLE II.—RESULTS OF TESTS TO DETERMINE MAXIMUM BOLSTER THRUST ON TRUCK SIDE FRAME

Test	Kind of service	Load on car, lb.	Load on truck side frame normal, lb.	Bolster thrust in lb. on side frame, maximum		Bolster thrust in per cent of normal load on side frame	
				Right	Left	Right	Left
1	Local	None	8,175	4,300	4,600	52.6	56.2
2	Local	66,000	24,675	5,900	9,200	24.0	37.4
3	Local	119,150	38,463	5,900	9,500	15.4	25.4
4	Local	91,000	30,925	8,500	7,500	27.4	24.2
5	Local	91,000	30,925	5,400	5,300	17.4	17.2
6	Local	91,000	30,925	4,000	5,100	13.0	16.5
7	Through fast freight	91,000	30,925	4,900	7,500	15.8	24.2
8	Through fast freight	91,000	30,925	7,300	7,300	23.6	23.6

Each test represents a round trip, Pittsburgh to Alliance.

Table III gives the results obtained with regard to the maximum force due to the twisting action of the spring plank on the frame.

TABLE III.—RESULT OF TESTS TO DETERMINE MAXIMUM TWISTING FORCE ON TRUCK SIDE FRAME

Test	Kind of service	Load in car, lb.	Load on truck side frame normal, lb.	Twisting of spring plank in lb. at center of truck, maximum	Twisting load in per cent of normal load on side frame
1	Local	None	8,175	3,000	36.7
2	Local	66,000	24,675	3,975	16.1
3	Local	119,150	38,463	4,975	12.8
4	Local	91,000	30,925	5,050	16.3
5	Local	91,000	30,925	5,050	16.3
6	Through fast freight	91,000	30,925	5,550	18.0
7	Through fast freight	91,000	30,925	6,100	19.6

First six tests represent trips from Pittsburgh to Alliance and return. Test 7 represents trip from Pittsburgh to Altoona and return.

From a survey of the results obtained in Table I, it will be seen that the maximum direct vertical pressure may vary from 182 per cent to 246 per cent of the normal load on the frame. The results, however, show that only in one case does the maximum load exceed 216 per cent of the normal load, so that for the design of a freight car truck probably a conservative figure would be 220 per cent of the normal load on the frame. It was found, however, during three round trip tests between Pittsburgh and Alliance, in which the standard M. C. B. springs were employed and the total weight of the car was 139,700 lb., that the springs went solid several times during each trip of 80 miles. This would indicate that a force of over 64,000 lb., which was the capacity of the springs, came upon them.

After it became evident that these springs were going solid, the car was equipped with four new sets, each having a capacity of 104,000 lb., and three round trips were made, the results of which are given as the last three lines in column V of Table I. These results indicate clearly that the standard M. C. B. springs do not have sufficient capacity and that forces of over 70,000 lb. are not unusual with a normal load of 30,925 lb. on the frame. Now if we consider for the average 100,000 lb. capacity car, weighing 40,000 lb., and loaded to 110,000 lb. capacity, making a total weight of 150,000 lb., that the wheels, axles, side frames and journal boxes are not carried by the springs, the normal load carried by each spring would approximate 33,000 lb. If we consider 220 per cent of this load, the maximum force for design would be 72,600 lb. for each frame. This is somewhat higher than most companies have used in their design, 68,500 lb. being a common figure. Then in view of the fact that the springs are going solid, it is almost impossible to predict what maximum force might be obtained due to the impact after the springs go solid. This may account for a great many failures in arch bar and cast steel side frames.

From a study of Table II, it will be seen that the force ob-

*From a paper presented before the Railway Club of Pittsburgh, February 26, 1915.

tained due to the end thrust of the bolster against the columns of the frame, referred to hereafter as the transverse load on the frame, varied considerably, but the maximum with the total weight of the car, 167,850 lb. was 9,500 lb., or 25.4 per cent of the normal load on the side frame. This 25.4 per cent of the average load on a side frame on a 100,000 lb. capacity car would be about 8,500 lb., and probably for safe calculating 9,000 lb. would be the maximum force for test purposes.

From Table III it will be seen that the twisting force reached a maximum in the trip from Pittsburgh to Altoona, and as this force is dependent upon the degree of curvature, this is readily explained, as this track has one or two curves of 8 deg. curvature, and the track between Pittsburgh and Alliance has no curve of over 5 deg. The maximum force obtained was 6,100 lb., from which we may assume that 6,000 lb. would probably be a safe figure for test.

The part of this paper which deals with the actual stress in the side frame, is taken from the results obtained from the tests of some 40 different designs of side frames, using three forces acting on the frame as described above. The exact amounts of the three forces were not the same as those found in actual service, due to the fact that the tests conducted to determine the stress set up in the side frame were made before the tests to determine the actual maximum force were carried out. For the purpose of this paper only the results from two different designs of frame will be considered.

As previously stated, the three forces, namely, direct vertical, transverse and twisting, were found to have maximum values for a 100,000 lb. car of 72,000 lb., 9,000 lb. and 6,000 lb., respectively. The actual forces used in the testing hereafter described were 68,500 lb. direct vertical, 6,000 lb. transverse and 5,000 lb. twisting. However, the results due to the transverse load have been increased 50 per cent and represent the stress due to a transverse load of 9,000 lb. There might be some question in this procedure, if it had not already been found in actual test that for all practical purposes the stress at any point in the frame was directly proportioned to the loads as long as the elastic limit of the metal was not reached.

For the purpose of determining the stress throughout the frame under the three different loads, the Berry strain gage was used. This gage is so constructed that the elongation in 2 in. gage length can be determined to .0002 in.

In preparation for a test the frame was mounted on two heavy supporting castings on the bed plate of the testing machine, this being a 300,000 lb. Riehle machine, located at the Granite City plant of the American Steel Foundries. The distance between the supports was equal to the wheel base of the truck. Double knife edge bearings over the supports were used. Cap castings over the support and filler blocks were also used to obtain the correct height for the spring seat and to support the knife edges. After the frame had been selected for the test, the points of reading were located, and small holes were drilled into the casting about 1/8 in. deep and exactly 2 in. apart, and these holes were then reamed to get a good firm surface for the points of the instruments to rest in.

The two frames to be discussed were from two general types of design, designated according to the cross section of the different members in the frames, namely, the L section and the I section. The L section type is as shown in Fig. 1, and will be referred to as frame A. This design of frame has been discarded by the manufacturers. The I section type, as shown in Fig. 2, is a later type of design and will be referred to as frame B.

RESULTS OF TESTS

When the design of a truck side frame has been discussed the question usually has been, "What factor of safety shall we allow?" An arch bar type side frame has a calculated factor of safety of from 12 to 16. This seemingly large factor was not used originally, but was arrived at by substituting larger and larger sections in an attempt to overcome breakage; yet a great

many arch bars break, and we usually say that the metal was not of the correct composition. The same is true of the cast steel side frame; defects are laid to the metal, while they may have been due to the design. In fact it appears that the average designing engineer has been using 25 per cent mechanical knowledge and 75 per cent judgment in the design of the different members that go to make up a freight car truck.

A careful study of the results of these tests will, I believe, bring out some important factors in the design of cast steel side frames.

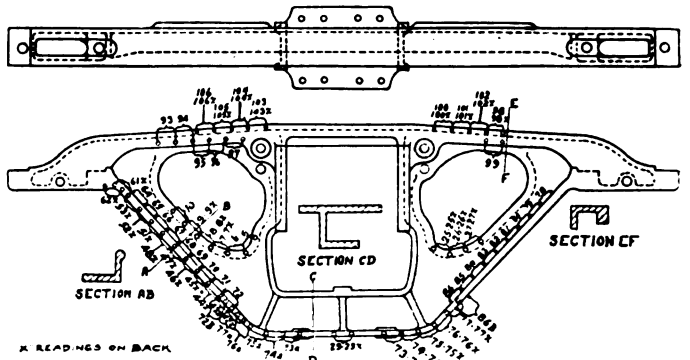

Fig. 1—Truck Frame Design A

The results show clearly that we have not been able to calculate accurately the stresses occurring in the different members of the frame. For instance let us look at the stresses obtained in the tension member of the A frame at readings 46x and 69. Reading 46x is on the web side of the L, and reading 69 was taken on the top of the lower leg of the L at the front or away from the web. The stress at point 46x for the direct vertical load is 1,600 lb. per sq. in. in compression, and at point 69 is 17,600 lb. in tension. Also at the points 8 and 8x, which were taken at the top of the L section, the 8x reading being on the back of the web and the 8 at the front, the 8x reading was 5,400 lb. in tension, and the 8 reading 16,500 lb., showing plainly that the tension member is attempting to bend in such a way

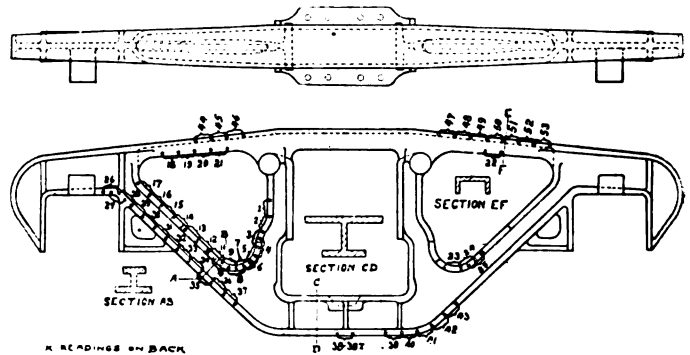

Fig. 2—Truck Frame Design B

that the two legs come nearer to the center of gravity of the member.

Another place where the stress does not follow what might be expected, is at the center and bottom of the frame at readings 29 and 29x. The stress at 29 is 2,700 lbs. compression, and at 29x is 27,000 lb. tension. If we stop to consider a moment we can see why this is true, for the outer edge at point 29 can bend up and relieve itself, thus leaving most of the load for the web side. Now if we look at the results obtained at the same points on the tension member of the B frame where the web is in the center, we find that while there is some variation, it is not so wide. For instance, if we take the reading at the bottom of the B frame at points 38 and 38x, it will be seen that the stress is 14,000 and 12,200 lb. per sq. in., respectively. The average of the two would then be 13,100 lb. Now if we should

average the two stresses at points 29 and 29x on frame A, we would obtain 12,150 lb. in tension, so it will be seen that the average stress for all practical purposes is the same. It is also true that if we should calculate the moment of inertia for the cross section of these two frames at this point, we would find them almost exactly the same.

The same comparison can be made at the lower end of the tension member; that is, the average stress for the direct vertical load on the A frame at points 46x, 69, 8 and 8x, is 9,200 lb., and for the same relative points on the B frame, that is points 34, 34x, 11 and 11x, it is 8,600 lb., which is for all practical purposes the same. For the comparison at the bottom of the frames, the maximum stress on the A frame is 27,000 lb. per sq. in., and 14,000 lb. per sq. in. on the B frame; and at the bottom of the tension member the maximum on the A frame is 17,600 lb. and 11,600 lb. on the B frame. That is, the maximum stress in the B frame under the vertical load is 50 per cent less in the bottom member, due to its symmetry of section, and 30 per cent at the bottom of the tension member in the B frame. This same saving is true in any comparison of the stresses due to the three loads. The maximum indicated stress on the A frame is 38,100 lb., at point 72, and there is a maximum of only 19,400 lb. at point 41x on the B frame.

There are a great many places where the stresses are over 20,000 lb. in the A frame, but none where they are that high in the B frame. In fact there are only 5 points on the B frame where the stress is over 16,000 lb., with the three forces applied, and there are 24 points that show over 16,000 lb. stress on the A frame; there are 7 points on the A frame that show over 25,000 lb. stress. This would indicate that the metal in the A

reduce the stress is at the bottom flange. The results of tests on four frames of similar design except as to the width of the bottom flange are given in Table IV. The maximum stress indicated was obtained by averaging the stresses at the positions on the different frames represented on the F: frame at points 41 and 41x, the weakest points on frame B under all loads.

TABLE IV.—EFFECT OF DIFFERENT WIDTHS OF THE BOTTOM MEMBER ON THE STRESS

Width of bottom member	Maximum average stress in bottom member due to vertical and twisting loads
3½ in.	24,900 lb.
4 in.	20,000 lb.
4½ in.	16,950 lb.
5 in.	13,300 lb.

The transverse load was not taken into consideration because of the fact that it had very little effect at this point, due to its distance from the point of application of the transverse load. The assumption was also made that the twisting force acts in both directions and the stress due to the twisting would at times be positive on both sides of the frame. It will be noted that the maximum average stress will be almost inversely proportioned to the square of the width of the bottom member.

From a survey of the results here given it may be seen that the stress is somewhat higher than might be expected. I am sure we would be very much surprised if we should test an arch bar truck under these methods. It is certain that where we have been assuming that we had a low stress, and that stresses of 8,000 to 10,000 lb. have been breaking frames, we will have to change our assumption and say that it will take over 20,000 lb. to cause cast steel to fail. I feel that cast steel will stand up under occasional stresses up to 20,000 lb. for a good many years.

If we stop to consider the cast steel bolsters we will find that they are getting loads that produce stresses of 20,000 lb., and they are standing up. For instance, a bolster that has a stress of 10,000 lb. under a load of 68,500 lb., which is the load used for calculations by some companies, will often receive double that load as indicated from the tests recorded in the first part of the paper; thus it is seen that 20,000 lb. stress will be produced in the bolster.

The B frame is not heavy; its weight is 435 lb., and as the M. C. B. Association committee last year recommended to the association a frame weighing 500 lb. for 100,000 lb. capacity cars, this frame could be increased 65 lb., and if the metal were well placed, the maximum stress under the three loads would not be above 15,000 lb. at any point. I am confident that if a cast steel frame was never subjected to a stress of over 15,000 lb. the life would be considerably more than the life of the car.

ECONOMIES IN FREIGHT CAR REPAIRS*

BY H. H. HARVEY

General Car Foreman, Chicago, Burlington & Quincy, Chicago, Ill.

One of the most important questions in regard to the freight car repair problem at the present time, is to get rid of the short draft timbers extending only to the body bolster and secured to draft sills by only about four 7/8-in. or 1-in. bolts. Cars thus equipped are not safe to handle in the heavy tonnage trains, and if their owners wish to continue using them, they should keep them on the home rails, regardless of the capacity of the cars. Only recently I saw a box car that had been given heavy general repairs. It had been repainted and made practically new above the sills. It had six 5-in. by 8-in. longitudinal sills, with short draft timbers depending entirely on the vertical bolts with which they were attached to the draft sills for support. Work of this kind is not economical, nor is it safe, and it should be discouraged in every way.

Many economical practices in freight car repairs have been brought out in the past few years, and I would invite your

*From a paper presented at the January meeting of the Western Railway Club.

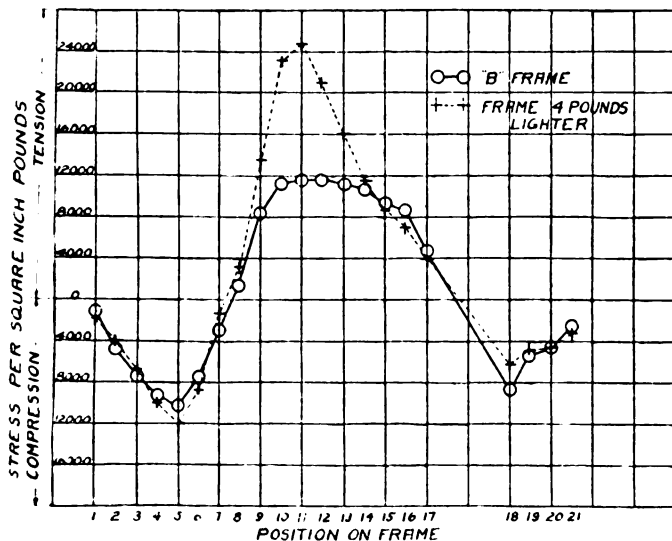

Fig. 3.—Comparison of Stresses in Frame B and a Frame Four Pounds Lighter

frame was distributed in such a manner that each pound was doing a more uniform share of the work than is the case in the A frame.

The value of a small amount of metal at the correct point is well shown in Fig. 3. Here are shown two curves, one plotted from the result obtained under the direct vertical load on frame B at the points 1 to 21, inclusive. These values are represented by circles. The other values plotted as crosses on the same ordinates are results obtained from a frame made from the same pattern as frame B, but 4 lb. lighter. This metal was placed as a narrow flange on the B frame, as shown at the top of section A-B Fig. 2. This flange started gradually at point 3 and continued to point 13, where it disappeared into a small bead on each side of the web. The maximum stress at point 11 on the B frame, was only 30 per cent of that obtained on the frame without this flange and which weighed 4 lb. less.

Another place where a small amount of metal can materially

attention to some that have come to my notice. Few if any of them are original with me, and most of them are in quite general use on various roads, but they may serve to encourage the bringing out of others.

Bolts $\frac{7}{8}$ in. and over in diameter can be welded or pieced out to any desired length under a Bradley hammer at a saving of at least \$15 per thousand bolts, and they will give satisfactory service.

Old $1\frac{3}{8}$ -in. truss rods from dismantled cars may be made into brake shafts by upsetting the lower end and truing up the drum under the hammer, and drawing the upper end down to the proper size for the ratchet wheel for a distance of about 4 ft. This makes a good stiff shaft, at a much less cost than when it is made of new iron.

Column bolts for arch bar trucks may be made from old $1\frac{3}{8}$ -in. body truss rods, by upsetting the two ends about 4 in. or 5 in., truing up under a hammer and leaving the center of the bolt $1\frac{3}{8}$ in. in diameter.

Old $1\frac{3}{8}$ -in. truss rods from dismantled cars may be hammered down under a Bradley hammer into 2 in. by $\frac{1}{2}$ in. flat, 1 in., $1\frac{1}{8}$ in., or $1\frac{1}{4}$ in. round, at a saving from \$5 to \$12 per ton over new iron. This, of course, does not apply where roads have their own rolling mill.

Coupler pockets that are cracked or broken at the rivet holes may be pieced out at a considerable saving. They also may be made from arch bars from dismantled cars.

Draft springs that have taken a permanent set may be heated, stretched to the proper length and retempered.

The flanges may be sheared from old truck channels, and the web made into plates for strengthening wooden draft sills between the end sill and the body bolster.

Brake shafts from dismantled box and stock cars may be cut off and made into brake shafts for coal and flat cars.

Brake rod jaws from dismantled cars may be cut off and used in making rods for repair work.

Metal brake beams from dismantled cars may be used for repair work on system light-capacity cars, or in changing cars from wood to metal beams.

Very good brake beam hanger supports may be made from old arch bars, which, when riveted to the channel type spring planks, make an economical way to change cars from outside to inside hung brakes.

Many malleable castings may be replaced with forgings or pressings made from scrap at the shops, at a less cost than the price of the malleable castings; carline pockets are a good example of this.

Old wrought iron body bolsters may be made into dead-wood plates, carrier irons, tie straps and many other things.

A very good bottom brake shaft support may be made from old arch bar tie straps.

The good part of broken sills, and good sills from dismantled cars may be made into sill splices, at a saving of about \$1 per splice.

The bottom two-thirds of short pieces of second hand sills can be used in making running board saddles, grain strips, blind girths, cripple posts, etc.

The lining and the lower course of roof boards from dismantled cars can, if carefully removed, be used for repairs.

The good sheathing on dismantled cars, if carefully removed, may be used below the side and end doors, for making end doors for repair work, and also for sheathing on bunk and company service cars. Old flooring from dismantled cars may be used to good advantage in making grain door nailing strips.

Oak carlines from dismantled cars can be made into first-class outside cross braces for side doors.

Good second-hand brasses may be rebored and relined at a considerable saving; if filled brasses are used it is often only necessary to rebore them.

Second-hand nuts, if promptly picked up from around the

repair tracks, can usually be reclaimed by simply giving them an oil bath. It pays to remove nuts from broken stub ends of bolts by hand.

Cracks in the floors of box cars can be calked with oakum and much flooring saved. By using flooring not exceeding 6 in. in width in box cars, the necessity of renewing on account of shrinkage cracks that cause leakage of small grain, will be materially lessened.

Use plates at least 3 in. square under the vertical rod heads at the side plate, also under the heads of bolts going through the sills, to prevent them from pulling down into the plate and sills. This applies to cars with wooden sills and plates.

The ends of old box cars may be greatly strengthened by applying $1\frac{3}{4}$ -in. end lining, extending from corner post to corner post. Many grain leaks may be avoided by fitting this lining tight at the floor and at the girth.

The road with which I am connected has found it good practice to build, at its own shops, from 500 to 700 stock cars a year, in order to use up the good material taken from dismantled cars, which would otherwise have been sold as scrap. These are 36-ft. cars with steel center sills and treated intermediate and side sills. In practically all cases we have been able to use second-hand material in their construction, with the exception of the lumber, steel sills, post pockets, brasses, bolts, etc. This second-hand material is carefully inspected, worked over and the worn parts removed, so that the cars are just as good as if all new material had been used in their construction.

DISCUSSION

J. A. Carney, Chicago, Burlington & Quincy, spoke of the success attained in building up worn collars on car axles by the oxy-acetylene process at a net saving of \$2 per axle. He also stated that the practice of tearing down old box cars had proved more economical than burning them; some lumber can be reclaimed, the scrap wood can be used for firing up engines, and the iron will be in much better condition to classify. William Queenan,* also of the Burlington, stated that the cars are torn down on a piece-work basis and that the lumber reclaimed more than pays for the cost of tearing the cars down, reclaiming the lumber and sorting the scrap. In a period of 11 months about 700 cars were torn down, from which \$15,000 worth of lumber was reclaimed, the lumber being rated at \$14 per 1,000 ft. The cost for doing this work was between \$11,000 and \$12,000, which leaves a very good margin of profit.

E. G. Chenoweth, Rock Island Lines, took exception to some of the items mentioned in the paper, stating that he believed if everything be considered, that the cost of reclaiming would be more than the purchase of new material, mentioning as one of the items to be considered the freight revenue derived from hauling the material. He called attention to the practice of one road, which uses old 100,000 lb. capacity axles for making axles for 80,000 lb. capacity cars, and old 80,000 lb. capacity axles for making axles for 60,000 lb. capacity cars, the axles being upset and re-turned.

J. F. DeVoy, Chicago, Milwaukee & St. Paul, spoke of the benefits derived from the use of rolling mills for re-rolling the scrap iron. He said that while in every case they would not prove economical on a cost basis, they were of great convenience in cases of emergency. He also mentioned the benefits to be derived from oxy-acetylene welding.

Other members spoke of the possibility of using scrap lumber for making sheds and buildings, and cases were mentioned where the metal roofs from torn-down cars were cut up and used as shingles. The Louisville & Nashville cuts off the flanges of the old metal roofs and re-flanges them, using them over again for car roofs.

*Mr. Queenan described the method of making stock cars from scrapped box cars in an article published in the *Railway Age Gazette, Mechanical Edition*, July, 1913, page 379.

SHOP PRACTICE

CLIPS FOR SECURING DATE TAGS TO STEAM GAGES AND SAFETY VALVES

BY C. L. DICKERT

Assistant Master Mechanic, Central of Georgia, Macon, Ga.

The accompanying drawings show a method of securing date tags to steam gages and safety valves and the special tools which have been developed to punch and form the

steam gages are removed and tested. All air gages as well as steam gages are tested at quarterly inspections and tags are applied to them in the same manner. The tool used

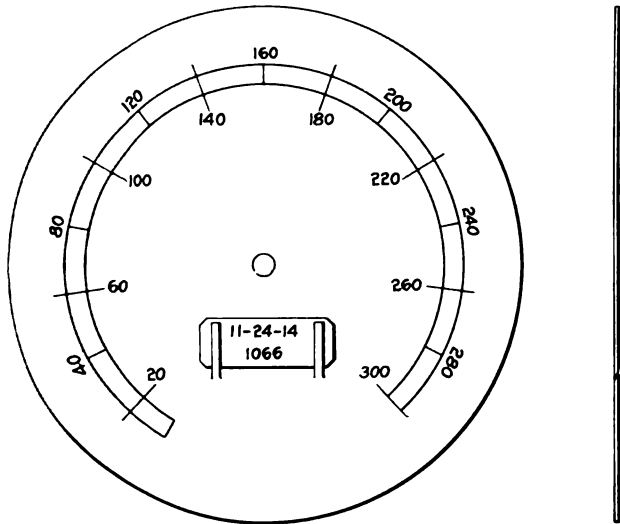

Fig. 1—Method of Applying Date Tags to Gage Dials

clips. Fig. 1 shows a steam gage dial in which the clips have been punched and a date tag inserted. The tags are made of stiff white paper on which the date of test and the

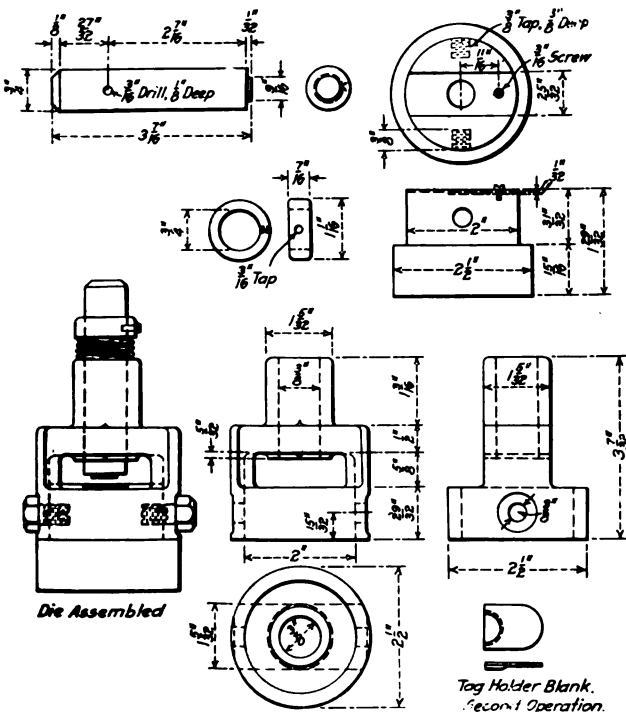

Fig. 2—Dies for Forming Tag Holders

engine number are written with ink. These tags are applied when quarterly inspection is made or for any reason the

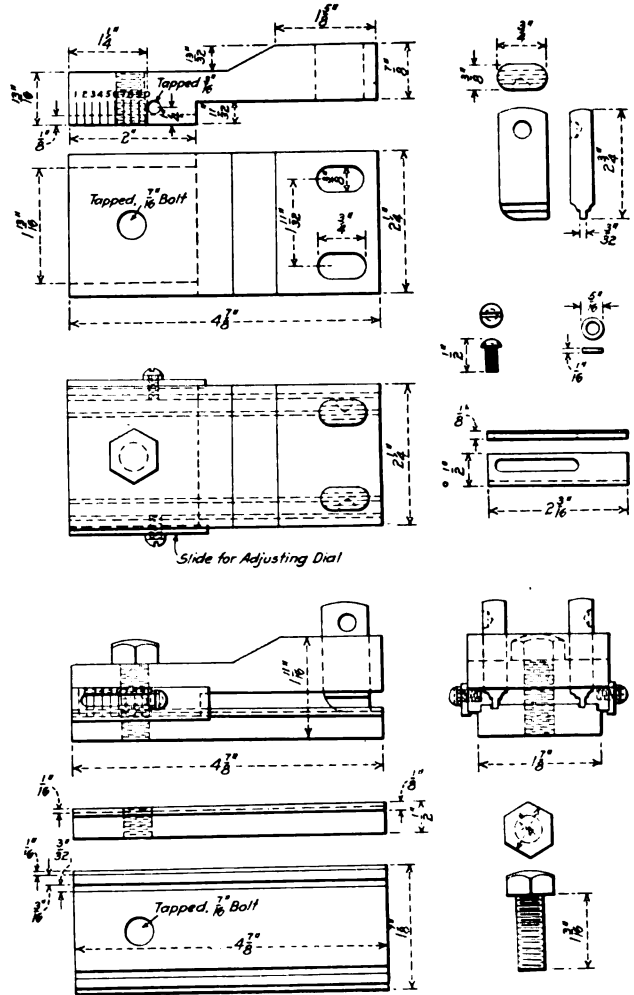

Fig. 3.—Tool for Punching Clips in Gage Dials

for punching clips in the gage dial is shown in Fig. 3. It consists of a die plate and a guide for the punches, held together by means of a 7/16 in. cap screw. The upper piece

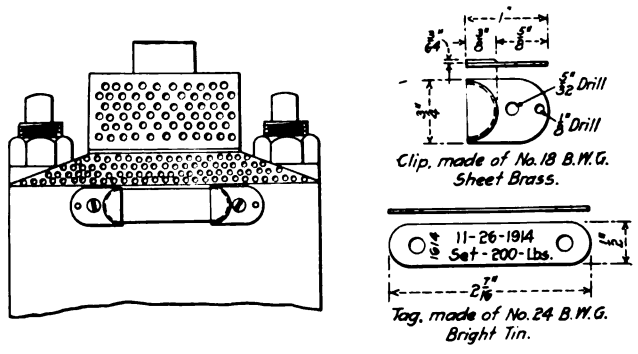

Fig. 4—Method of Securing Date Tags to Safety Valves

is lipped over the edges of the die plate to secure proper alignment. Graduated slides are secured to the side of the

device, by means of which the gage dial may be adjusted to secure the proper location of the clips.

The method of securing tags to the safety valve, together with details of the tags and clips, are shown in Fig. 4. The tags are made of bright tin on which are stenciled the engine number, the date tested and the pressure at which the valve is set. A tag may readily be slipped into the clips and after once in place there is no danger of its losing out. When the safety valve is next tested the tag may be pried out with a screw driver and another one inserted. Blue print instructions, showing the method of application and removal, are sent to all outlying points where quarterly inspections are made.

Special tools are provided for cutting and forming the clips. The blanks are punched by the tool shown in Fig. 5. Its body is made up of two parts, the upper part forming a guide for the punch and the lower part containing the die. The punch is fitted into a sleeve within which it is secured from turning by means of a flat dowel, and a stem is screwed into the sleeve against the top of the punch. The sleeve is prevented from turning in the body of the punch by means

This tool consists of a die with a circular depression at the center 1/32 in. deep and a forming tool on the face of which is a corresponding extension 9/16 in. in diameter. By placing the blank in the slot shown in the face of the die with the straight edge on the center line, the tag holder is formed by a blow of a hammer on the stem of the forming tool.

The clips are secured to the safety valve cage by means of one screw and one rivet in each. The holes in the cage are drilled by the use of a jig.

POINTS FOR APPRENTICES TO PONDER

BY H. L. LOUCKS

Machine Shop Foreman, Erie Railroad, Dunmore, Pa.

Keep clean. Keep neat; then watch the results in the improvement of your workmanship.

Don't keep your eye on the other fellow for in the meantime your own work is being neglected; at the same time don't let the other fellow "get something over on you."

Take good care of your tools. A competent machine shop

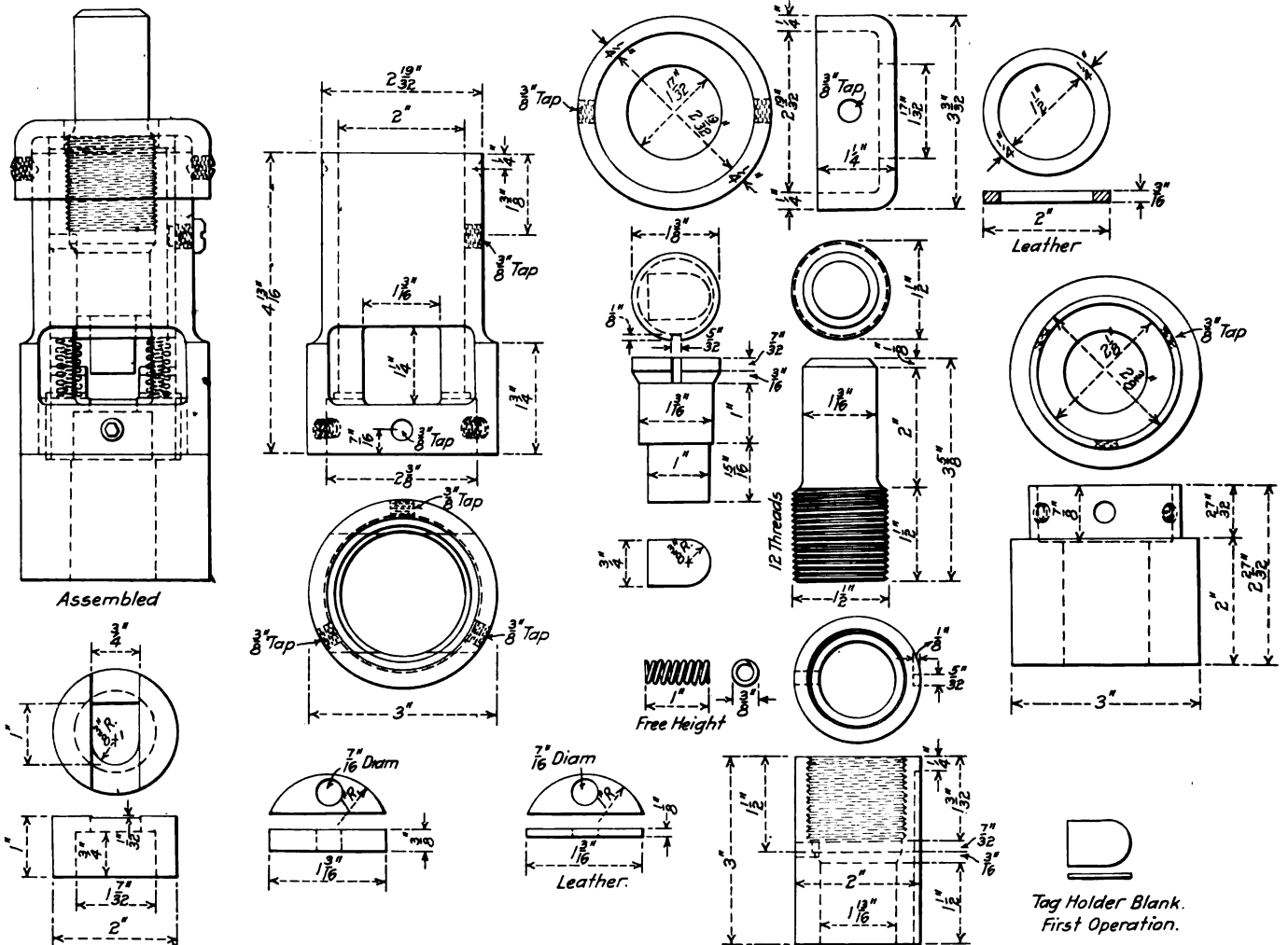

Fig. 5—Punch for Cutting Tag Holder Blanks

of a special screw, the end of which slides in a vertical groove in the side of the sleeve. A difference of 1/8 in. is allowed between the diameters of the die and its pocket in the body to provide for accurate alinement. The die is secured in position by means of three set screws, which also hold the two parts of the body together.

After the blanks have been punched, the pockets for the ends of the tags are formed by the tool shown in Fig. 2.

foreman, by an inspection of your outfit, can tell pretty well what class of work you will do.

Make every move count. This life is the greatest game you will ever play in, and don't forget that there are some good places vacant.

Systematize your methods of working.

Be cheerful. Don't watch the clock; as long as you do the hands move the wrong way.

Don't watch the foreman. He is watching you.
 Don't destroy your employer's property. Remember it belongs to the firm from which you get your living.

CHUCK FOR FINISHING BOILER CHECK BODIES

BY W. W. ELFE

Machine Foreman, Central of Georgia, Macon, Ga.

The illustrations show a chuck for finishing boiler check bodies from which good results are being obtained in service. It consists of a cast iron block cored to receive the boiler check body, which is firmly held in position by means of a wrought

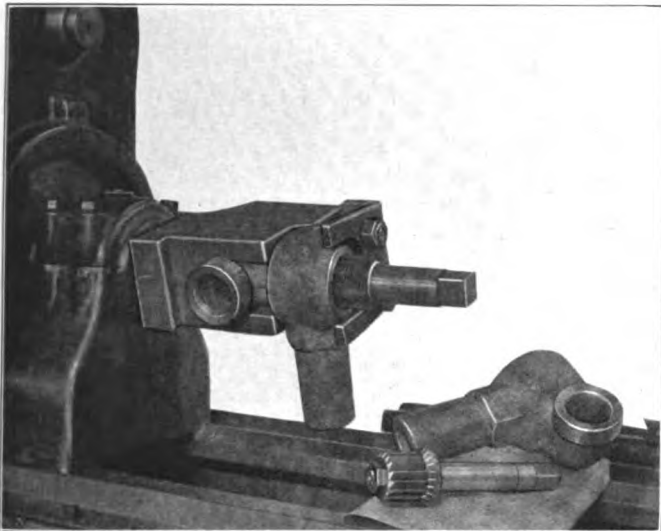

Finishing the Valve Seat and Threading for the Cap

iron clamp and two studs in one end of the casting. Two sides of the chuck at right angles to each other are bored and threaded to fit the lathe spindle. These are opposite the branch pipe connection and check valve seat of the boiler check. When secured in the chuck it is possible to com-

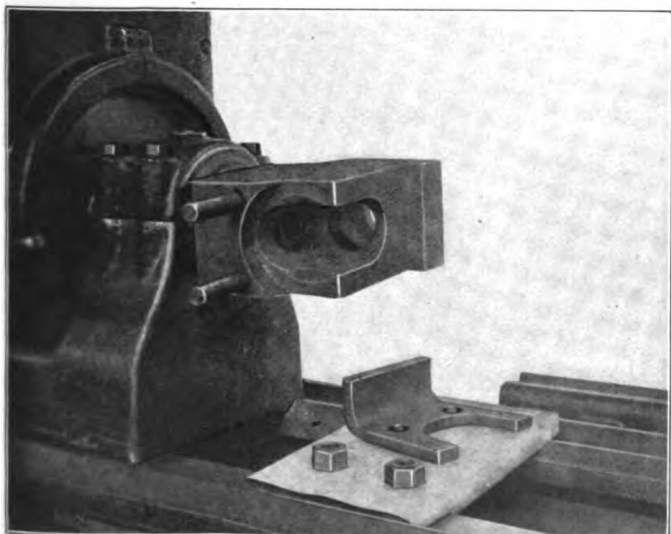

Chuck for Finishing Boiler Check Bodies

pletely finish a boiler check body with the exception of the boiler connection without resetting the work. The check valve seat is finished by means of a special reamer shown in one of the illustrations and the threads for the cap are

tapped on the lathe. The construction of the chuck requires a slightly bent turning tool for finishing the branch pipe connection and the threads are chased by means of a special threading tool. The end of the connection is finished by means of a ball reamer. The boiler connection is finished

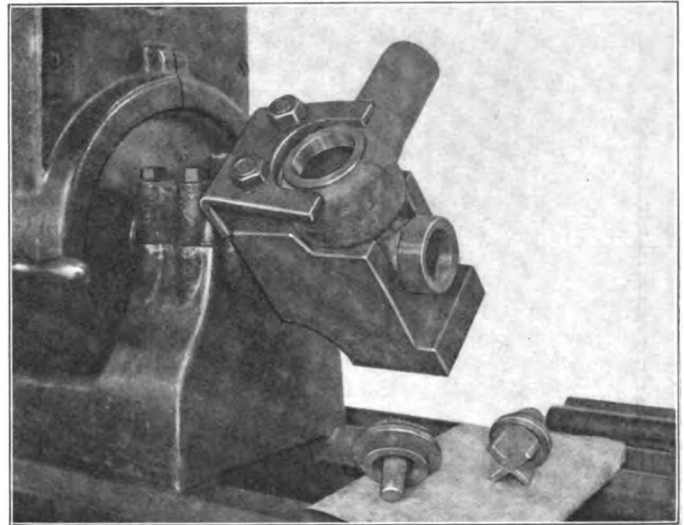

Chuck in Position for Finishing the Branch Pipe Connection

when the check is applied to the boiler. This work is done on centers, a pipe center being used in the tailstock.

SHOP NOTES FROM THE SOO LINE

BY B. N. LEWIS

The devices described below are in use at the Minneapolis shops of the Minneapolis, St. Paul & Sault Ste. Marie and have been found to be especially convenient on the work for which they were designed.

LIFTING HOOKS

One of the illustrations is a sketch of a lifting hook used for removing heavy work from lathes and other machines in which the work is held on centers. It is of special advantage where a positive lift is made, such as with electric crane service. Its

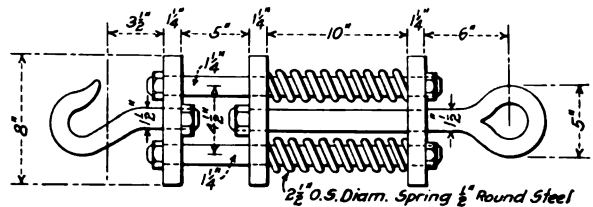

Lifting Hook for Heavy Work

construction is clearly shown in the illustration, and by its use the danger of bending the centers or pulling the work out of the machine before the centers have been released is practically eliminated. The compression of the springs will indicate when sufficient force has been applied to suspend the load.

ATTACHMENT FOR GRINDING CYLINDER HEADS

An arrangement for giving the oscillating motion to a cylinder head when it is being ground to the face of the cylinder is shown in another of the engravings. The arm from the cylinder head is attached to the pitman, which is driven by means of an air motor through the gears, as shown in the illustration. The frame work for the machine is made of 1 1/2 in. by 3/8 in. bar iron and is attached to the floor of the shop by lag screws. The cylinder arm and the pitman are provided

with a series of holes to permit adjustment. With this device the work requires the services of only one man, and it may be

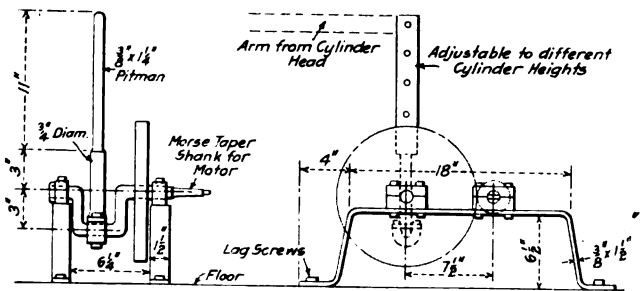

Attachment for Grinding Cylinder Heads

done in a shorter period of time with very satisfactory results.

PORTABLE HYDRAULIC PRESS ATTACHMENT

A device similar in nature to that referred to for grinding cylinder heads and used for operating the pump handle of a hydraulic press is also illustrated. It is made up of a train of gears taken from an old hand car, a crank axle and a driving shaft to receive an air motor. The frame holding these parts is bolted to the base of the hydraulic press as indicated

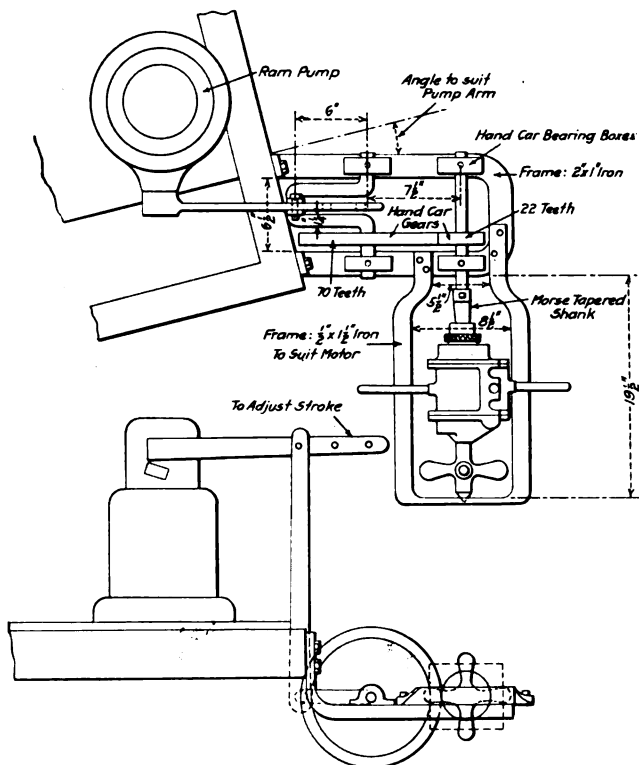

Hydraulic Press Attachment

in the illustration. The stroke of the pump is adjustable. This device has been satisfactorily used for operating the press when removing and applying crank pins or driving axles. It saves the time of the men in doing the work, and in some instances it will eliminate the necessity of having more than one man on the job.

TIRE LIFTING HOOK

One of the drawings shows a lifting hook used for tires when they are being set or removed. The clamp is easily applied and eliminates the necessity of using set screw clamps which take time to apply, and which often stick when they become heated. Several sets of screw clamps are also required to accommodate the different widths of tires, but this device will take care of all sizes of tires.

FEED VALVE TESTING CLAMP

Another device in successful use in these shops is a quick-acting clamp to be used when testing air brake feed valves. The valve is placed in the clamp at A, shown in the engraving,

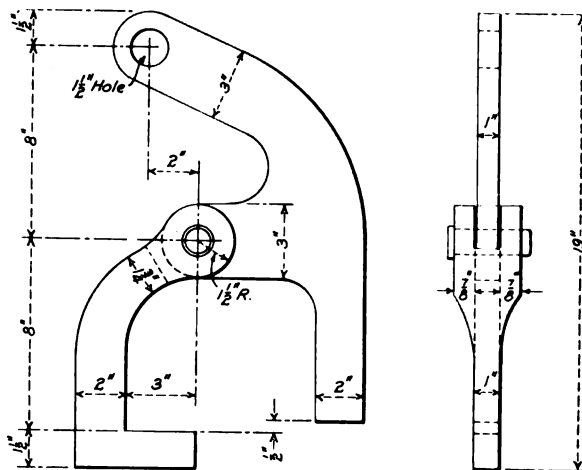

Lifting Hook for Tire Setting

1/2 in. dowels being applied to fit in the bolt holes of the feed valve. By screwing down on the clamp wheel B, the feed valve is securely clamped to a leather gasket as shown, while the air

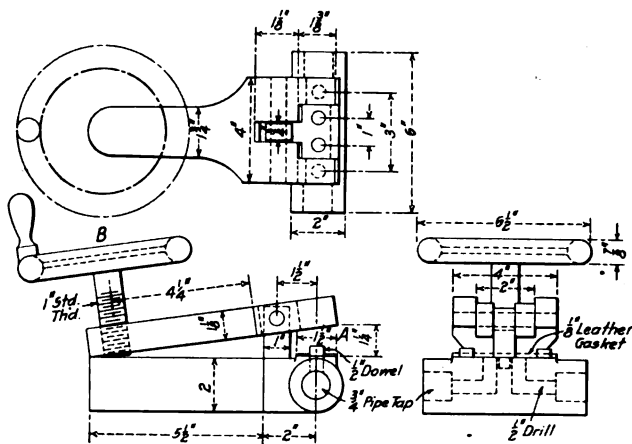

Clamp for Testing Feed and Reducing Valves

pressure is admitted to the brackets of the clamp and thence to the valve in the same manner as on a locomotive.

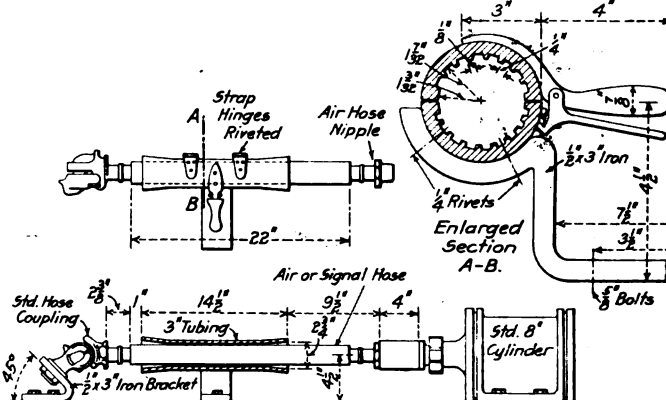

Device for Mounting Air Hose

MOUNTING AIR HOSE

Another illustration shows an arrangement that has proved satisfactory in mounting air or signal hose in one operation. A

piece of steel tubing 14½ in. long, fluted as indicated, is held in a clamp attached to the work bench between an air cylinder and an air hose coupling. The nipple is placed on the end of the air cylinder plunger, and as the air pressure is applied both the coupling and the nipple are forced into the hose. The steel tubing is fluted in order to reduce the friction between it and the hose. All material used in the construction of this device is taken from stock usually found in a railroad shop.

ENGINE HOUSE ORGANIZATION*

BY W. P. HUNTLEY

General Foreman, Chesapeake & Ohio, Ashland, Ky.

The accompanying chart shows a system of organization which is applicable to large or small engine houses by adding to or reducing the forces under the different headings.

The important part in roundhouse work is to keep the power moving, but in doing so to know that the engines sent out are in condition to make the trip successfully, with minimum risk of tying up the road by an engine failure. To accomplish this successfully, there must be system. A roundhouse cannot be run

should really be taken out of the English language so far as he is concerned, and the word "try" substituted.

Men with fixed occupations should be directly under the roundhouse foreman, as shown by the chart. The boilermaker foreman and gang foreman are placed in immediate touch with the men in their departments; this enables them to know each job and its progress. These men are required to keep accurate detailed records of the work done by the men in their departments, in an 8 in. by 12 in. record book, indexed with the engine numbers, there being several pages to an engine. The work and the name of the workman is entered therein daily. This is a very useful book in lawsuits, as it contains facts and prevents guess work.

An engine inspector and a good inspection pit are two of the most important factors in engine house organization. If there is no inspection pit, a pit of some kind should be made. At this point, engine crews are relieved in the yards, one mile from the roundhouse and shops. The engines are handled by hostlers to and from the yards. The hostlers keep what is known as a roundhouse record book of the engines they handle. They enter the train number, the engine number, the names of the engine crew, the time the engine arrives on the inspection pit and the

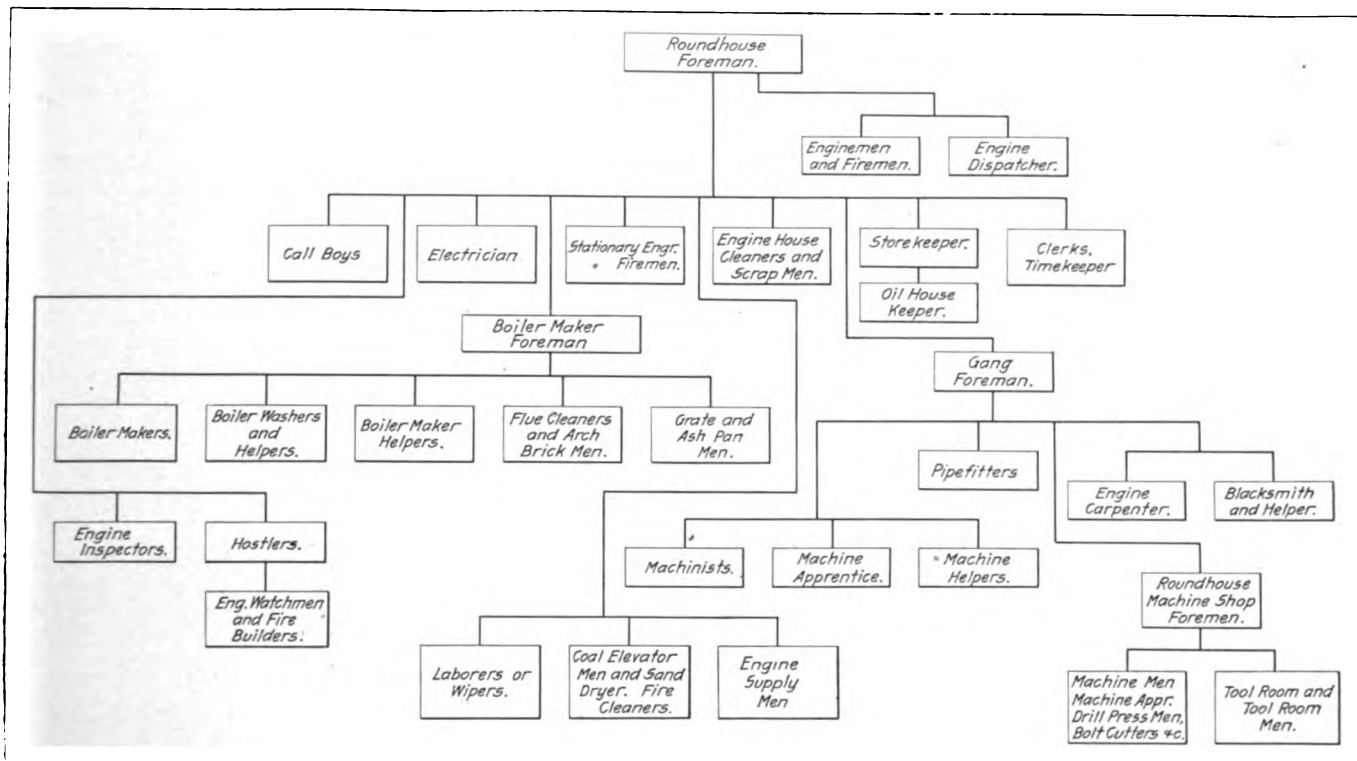

Chart for Engine House Organization

successfully unless there is system in the work. The number of men employed should be determined by the number of engines despatched. A machine shop is a necessary addition to a roundhouse terminal at divisional points, but not where an erecting shop is located, as the latter can be depended on to take care of the roundhouse requirements. Neither is the machine shop foreman always necessary; the size of the terminal governs this. Usually the gang foreman will handle the machine men. With first-class facilities, a plan can readily be worked out, but with most railroads feeling the effects of legislative agitation, conditions must be taken as they are, or as they develop, which means the facilities are usually considerably behind the demands and systematic methods are necessary to accomplish the desired results. A roundhouse man should never say "Can't." The word

time the engine is ready for service. They also keep in this book a record of any delays encountered, to and from the yards. This book is checked by the engine despatcher or clerk with the engine house record book, when he makes his daily report of engines despatched. When an engine comes in from a trip, it is handled to, and left by the hostler on the inspection pit; the hostler delivers the engineman's work report to the engine inspector, who makes his inspection, entering the result on a regular work report over his own signature. He attaches the engineman's report to the one he makes and delivers them to the roundhouse foreman, who figures on the engine from the work shown. The engine watchmen handle the engine from the inspection pit to the ash pit, to the coaling station for coal and sand and over the turntable into the roundhouse. In the meantime, the two work reports are in the hands of the gang and boiler foremen, slips are made for the different jobs and they

*Entered in the competition on Engine House Work, which closed July 15, 1914.

are ready for the engine when it is placed in the roundhouse. These slips are given to the men and are returned when the job is completed. The name of the man is entered on the slip with the length of time taken on the job. These slips, with the work reports of the engine inspector written up and signed, are filed in book form. As the books are filled they are filed in the foreman's office. This arrangement avoids the necessity of the workman reading the full report, and saves time as the job is specialized and the undivided attention of the workman given to it.

One of the most difficult problems of the roundhouse foreman is keeping in touch with the enginemen and firemen, to avoid a surplus of men in the pool or extra lists. The whereabouts of each man should be carefully kept, that is, those off on leave or from other causes. The call boys or engine callers should make day and night lists of the trains run and the men used, and these lists should be used daily by the clerk and engine despatcher when revising the lists and blackboards, the revised lists being furnished the callers and roundhouse foreman daily. The condition of the work on engines should be transferred by memorandum by the day and night roundhouse foremen daily.

Not every back shop mechanic will make a good roundhouse man; I have reached the conclusion that this will also apply to helpers and laborers. On the other hand, there are comparatively few roundhouse mechanics, helpers or laborers who will not make good in the back shop. This is due to the back shop work being done more mechanically, the roundhouse work requiring more resourcefulness. Invariably in employing a mechanic I ask him about his roundhouse and back shop experience and I find the man that has served a part of his apprenticeship on roundhouse work, does better, quicker work, than the man from the back shop who, as a journeyman, has worked in the roundhouse. I believe that machinist and boilermaker apprentices should be given roundhouse experience during the last half of their third year to develop the confidence requisite in a good roundhouse man and to provide men for this service in the future. It is becoming more difficult to get satisfactory common labor for roundhouse purposes. This class of men prefer back or erecting shop conditions or the work in other industries; invariably the latter pay higher wages, which attract the better element. The roundhouse man necessarily accepts the conditions as presented and must improve them if he can. A record book of applicants who appear eligible, with name, residence, reference and the result of an investigation of the references entered therein will prove of service.

Monthly statements should be compiled showing the detail cost of all classes of labor and roundhouse material; not engine material or supplies that are charged to the different accounts but material used to run the roundhouse and shop, on a basis of the kind and number of engines despatched. The statement, covering all roundhouses, should be furnished to each roundhouse foreman with a direct letter to each man, calling attention to any particular item in the comparison that fits his individual case; comparisons make ambitious men think.

Foremen should endeavor to instill confidence and faith in the men. It is a good asset and they will respond more quickly than might be expected. It seems to me that the secret of success in organization is in knowing just how far you can place responsibility on your men, from the highest to the lowest in the ranks. When you have decided this, build up on it and you will create an organization that will be strong as a whole and will produce results.

ANTHRACITE COAL.—Shipments of anthracite coal are reported for the calendar year 1914 as amounting to 68,302,961 tons, which is 766,667 tons less than in 1913. The total output, including an estimated 3 per cent sold to local trade and to employees, was over seventy millions, and in addition to this an estimated quantity of eight millions was used in operating the mines.

WATER GAGE COCKS

BY PAUL R. DUFFEY

A new style of locomotive water gage cock, which is the invention of Harry Glenss, Portsmouth, Ohio, is shown in one of the illustrations. In designing this cock it was desired to obtain one that would meet the rigid requirements of the Interstate Commerce Commission and permit the user easy access in making repairs while the locomotive is under steam. It will be seen that the device is made in such a manner that the valve may be easily removed and replaced in case of necessity. To do this the stem and cap are first removed, when the valve may be taken from the body, the passage from the boiler being closed

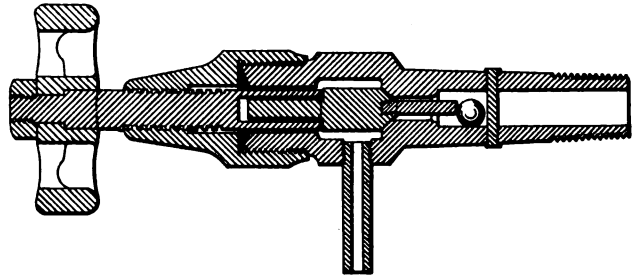

Glenn Gage Cock

by the ball valve. In regrinding while the boiler is under pressure, the tail piece, which holds the ball valve from its seat, is removed. The valve is then reground on its seat by means of a special socket made for that purpose. The ball valve prevents the escape of steam from the boiler during this operation. If the gage cock is used frequently no trouble is experienced from the ball valve becoming covered with scale.

Another simple design of water gage cock is also illustrated. It is simple in construction as well as efficient from a service point and meets the requirements of the Interstate Commerce Commission. The possibilities of leaks are much less than in many of the types now in use. The valve consists of the handle, the spindle, the packing nut, the removable section of the body,

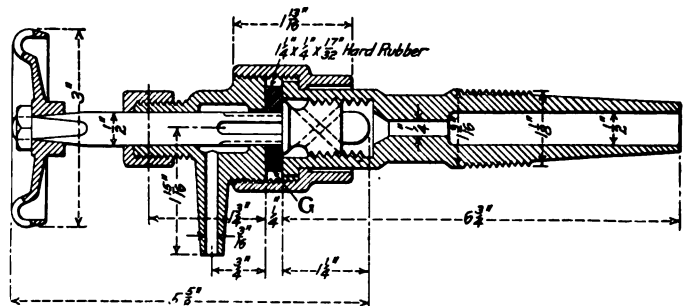

Water Gage Cock with Special Features

the drip tube, which may be cast integral or made separately, as desired, the connecting sleeve, the body and the gasket *G*. The cock when in the position shown does not permit the passage of steam to the section beyond the gasket *G*, and when the spindle is screwed down on the seat in the body it is again closed. To repack the nut, the cock may be either as shown or closed against the seat in the body. To renew the gasket *G*, the cock is closed tight. When in the closed position all parts except the spindle and body may be removed and cleaned or renewed as occasion may demand. Any lime in the outlets for steam and water in the spindle may be loosened and readily blown out as soon as the reassembling is completed.

SAVING TIME.—The element of greatest expense in manufacturing is time, for a little time wasted here and there will lessen and possibly destroy, the year's profits.—*American Machinist.*

SHOP EFFICIENCY

BY ROBERT N. MILLER

Today we are living in an era of productive efficiency where-in all are striving to attain the greatest possible output with the minimum of effort. While as a whole there are many praiseworthy features in the systems developed to attain this end, yet, due often to the method of introduction, several very undesirable features have arisen which have often discredited the whole movement toward scientific management.

To attain the greatest efficiency in an industrial organization there is needed the harmonious co-operation of all the forces involved, and to obtain such co-operation there must exist a feeling of mutual trust and confidence throughout the organization. We often find cases where a so-called efficiency system has been introduced in a plant and yet, after a period of sufficient length for its proper introduction, it has lapsed, leaving the organization with far less of the spirit of co-operation than existed before the system was inaugurated. In fact the system, mainly because of those to whose hands its introduction was entrusted, has really done more toward sewing seeds of discontent among the employees than perhaps any innovation which has been introduced up to the present time.

Wherever the application of scientific management has been honestly worked out we can find material benefit to both the employer and employee, but under the cloak of efficiency engineering we can still find a great deal of faking carried on. It is because of the faking that the chief complaint is raised against efficiency which has for its only object the speeding up of both men and machines. Scientific management rightly construed means the proper correlative action of employer and employee—a co-operation resulting in benefit to both.

The introduction of a system of scientific management must be gradual. Human nature resents the sweeping criticism inferred in an abrupt change of methods. Scientific management is generally accompanied by many changes in methods, and therefore to be ultimately successful it must rely upon winning the sympathy and co-operation of the workman, as well as the foreman and officer. This cannot be accomplished by the mere issuing of instructions; it requires a painstaking campaign of education as to the purposes of the system. The efficiency engineer must, therefore, be a man of extreme tact; he must possess a suaveness that will at all times insure confidence, and above all things else, he must be a keen judge of human nature. The failure of the efficiency engineer to exercise these qualities is one of the chief obstacles in the way of scientific management.

Changing over to the new basis cannot be expected to produce phenomenal results at the very outset, but must be able to show some improvement in a short time. Educating the workman to the system and above all, convincing him that it is finally to result in a larger pay check for him, of course takes time, as it requires an individual study of every man in the shop. It can, however, be greatly facilitated by means of shop demonstrations and lectures. The modern apprenticeship system, wherein the boy is taught the most efficient methods, and above all, where he is taught to use his resources rather than blindly to follow precedent, has done much toward paving the way for the successful application of the principles of scientific management.

It often happens that increased plant output is obtained at the expense of the employees alone rather than by improvements in the methods of production. In order to successfully operate an efficiency system the men must be assured that their increased productiveness will not be offset by decreased pay. Their confidence in the integrity and sincerity of the management must be retained. Ground for the least feeling of suspicion or mistrust tends to destroy the morale upon which the success of the system entirely depends.

PACKING IRON FOR JOURNAL BOXES

BY W. E. JOHNSON

Storekeeper, Chicago & North Western, New Butler, Wis.

The accompanying illustration shows an improved packing iron, designed by P. S. Hoyer, car foreman of the Chicago & North Western at New Butler, Wis. The principal feature of this packing iron is the small hook which is placed on the shoulder of the iron for lifting the journal box cover, thus saving the time of turning the iron around to use the handle for this purpose. The length of the spoon is 14 in. instead of 10 in.,

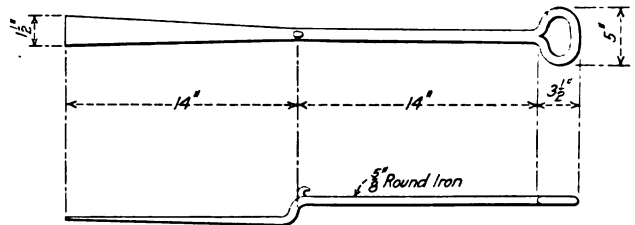

Journal Box Packing Iron with Improved Features

this being sufficient to reach the depth of the largest journal box, without the hook interfering in any way with the manipulation of the packing iron. It is also short enough to prevent contact with the ties when the cover is being raised. This new packing iron has been used at New Butler with very good success, and saves considerable time in inspecting journal boxes.

SPECIAL BEADING TOOL AND BOILER PATCH BOLT

BY PETER E. McINTOSH

Boiler Maker Foreman, Michigan Central, Kalamazoo, Mich.

The beading tool shown in the drawing is designed to prevent the formation of a groove in the tube sheet at the outer edge of the bead on the tube. It is especially intended for use in the roundhouse where it may be handled by an inexperienced man without danger of injury to the tube sheet. It does not require as much material to form the bead as the usual type of tool as it draws the tube out instead of shouldering it up. The foot of the tool should be ground off to fit the size of the tubes with which it is to be used. Many ordinary beading tools are lost by being shot through the tubes with an air hammer. The

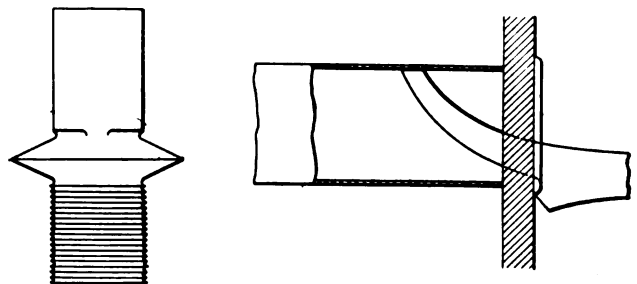

Patch Bolt with Groove Above the Threads. Beading Tool Designed to Prevent Grooving of Tube Sheet

shape of this tool is such that it will not enter the tube when in operation farther than as shown in the engraving.

The patch bolt shown in the illustration was designed and has been successfully used by the author for more than a year. Some of these bolts have been placed on the fire line in the firebox and none of the patches in which they have been used have required calking since they were applied. The distinctive feature of the bolt is the removal of the last thread under the countersink by means of a round nose lathe tool, thus forming a slight groove above the threads. Where straight bolts are

used without the formation of such a groove, if the thread is not cut close up to the edge of the countersink and the patch is countersunk to a feather edge, the bolt will tighten into the sheet before a firm contact between the head and the countersink of the patch has been secured, the patch not being drawn firmly to place. On the other hand, in endeavoring to cut the thread close up under the head of the bolt, the edge of the tool will usually cut into the head and spoil its surface. This prevents the proper seating of the bolt in the patch.

REBORING AIR PUMP CYLINDERS

BY J. A. JESSON

The drawing shows a machine which was designed to re bore air pump cylinders without removing them from the center piece. It consists of a belt-driven, star feed boring bar mounted upon a surface plate, the operation being very similar to that of the portable boring bar used in re boring locomotive cylinders. The pump is placed on the bed of the machine and the cylinder to be re bored is slipped over the end of the bar. A split taper bushing of brass is then inserted in the stuffing box and the packing nut screwed on just far enough to hold the bushing in place. The pump may then be placed on the boring bar, the outer end of which is inserted through the taper bushing and centered by tightening the gland nut. After the cylinder has been secured

on the end of the star feed screw at *B* the cutter head is fed into the cylinder until it strikes the center piece, and the collar *C* of the automatic feed stop is clamped to the pawl release rod by means of a set screw. The cutter head is then run back out of the cylinder, the tools placed in position and the machine started. The tool posts or jaws have a slide bearing in the face of the cutter head which provides for radial adjustment. Cams which are shown in detail on the drawing control this adjustment and are so designed that a maximum variation of $\frac{1}{4}$ in. in the diameter of cut may be effected without disturbing the setting of the tools. When boring the cylinder the tools are adjusted to the minimum diameter. After the bore is completed the cutter head is fed up to the counterbore at the inner end of the cylinder, the cams adjusted by means of a wrench and a cut taken from the counterbore. The outer counterbore may be finished in the same way, the entire operation requiring but one setting of the tools. A second adjustment of the automatic feed might be desirable before finishing the outer counterbore.

MACHINE FOR BORING DRIVING BOXES

BY E. C. GAINES
Norfolk & Western, Roanoke, Va.

About a year ago the driving box work at Roanoke became so heavy that it could not be handled with one machine. There

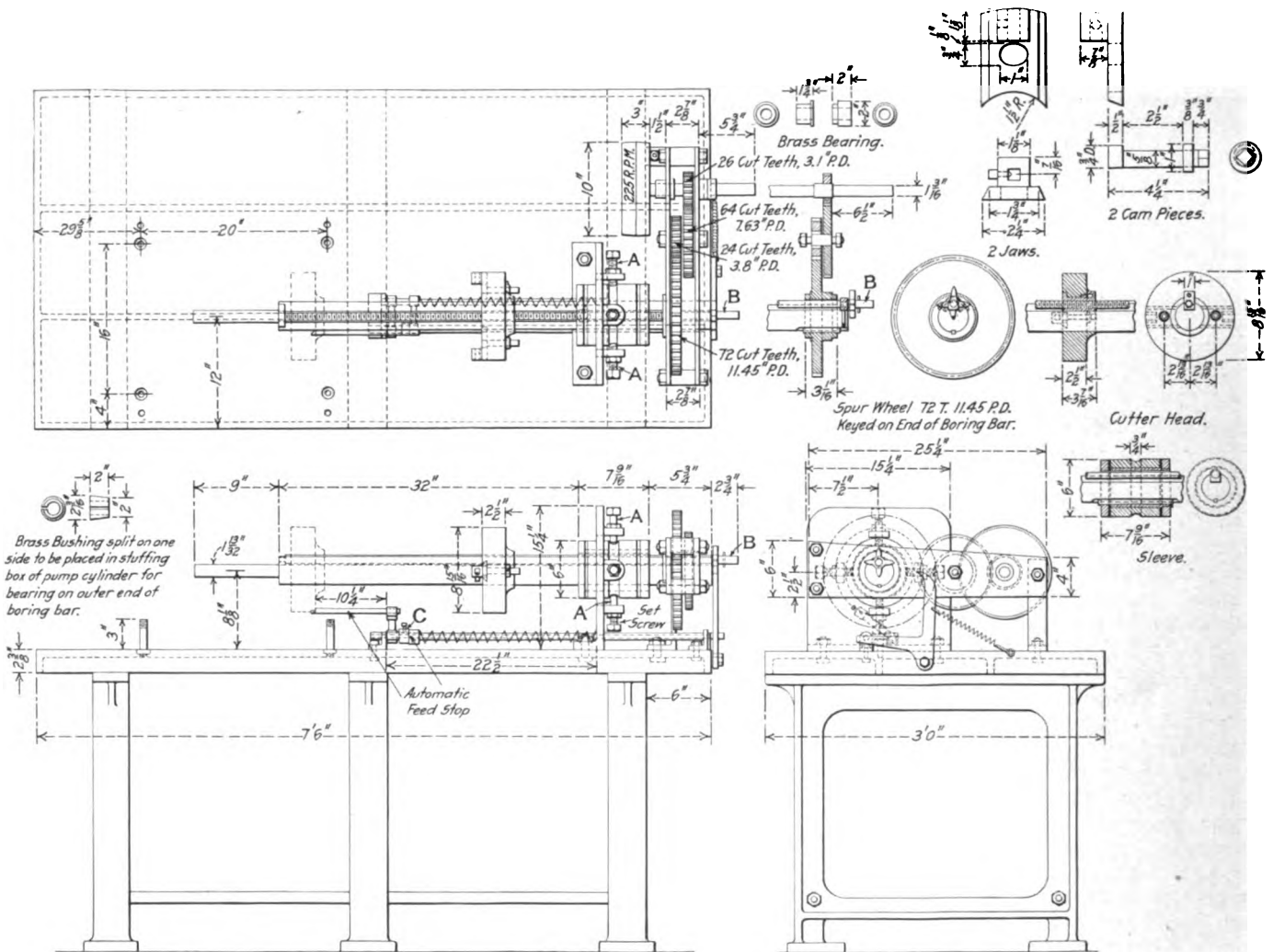

Machine for Re boring Air Pump Cylinders Attached to the Center Piece

to the bed by means of clamps on the four studs shown in the drawing, the cutter head is set in the counterbore and centered by means of the set screws shown at *A*. By means of a crank

were no other machines available for this job, and after some careful study it was decided to convert an old car wheel boring machine into a machine suitable for boring driving boxes.

The car wheel boring mill was first stripped and the frame set up on a planer where the top of the base was planed down to form a good bearing for the stationary table. A table 5 in. thick and having a 40 in. by 40 in. top with three T slots was

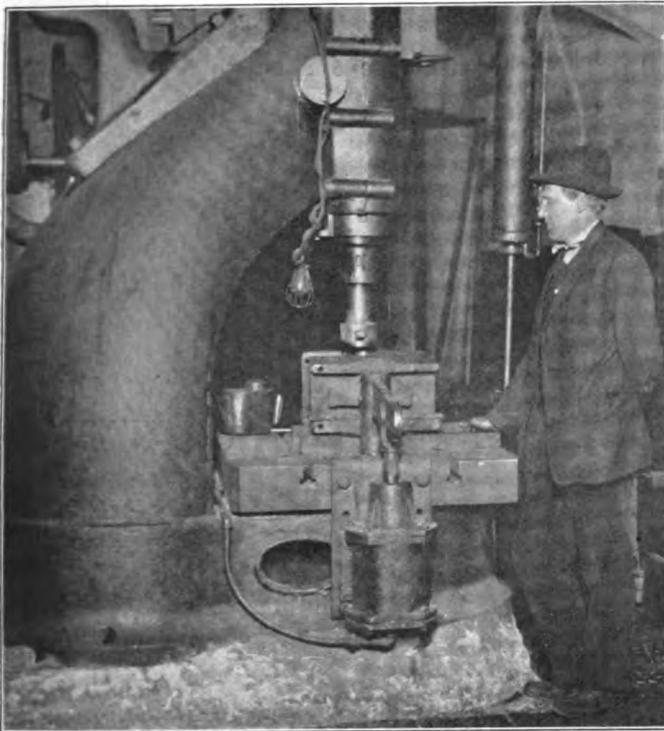

Old Car Wheel Boring Mill Converted for Boring Driving Boxes

made and securely bolted to the frame of the machine. A bracket to carry an ordinary belt drive was cast and fitted to the back of the frame, the boring bar being driven by means of bevel

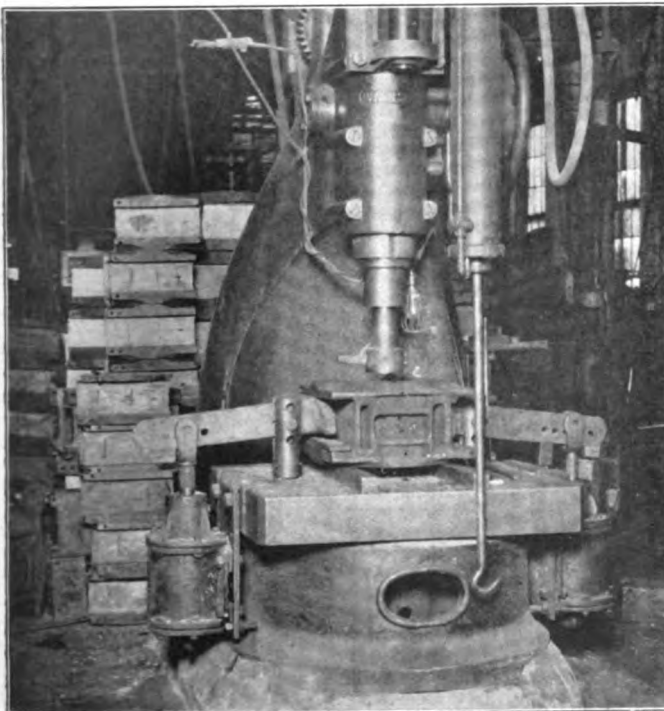

Table and Clamping Device on Converted Boring Mill

gears. The original sleeve was bored out and bushed at both ends to take a 4½ in. boring bar. The original feed, belt driven from the driving shaft, was used, but it was necessary to replace

the original lever counterbalance with counterweights inside the frame, two sheaves being secured to brackets within the frame for this purpose. A simple clamping device, the construction of which is clearly shown in the illustration, was installed on the machine, each side of which is operated by an 8 in. air cylinder.

The pulley ratios are such that the bar has a speed of 40 revolutions per minute; the feed is ⅛ in. per revolution, the same speed and feed being used for all sizes of boxes. The time required to bore a box varies from 12 min. to 20 min. The total cost of converting this machine did not exceed \$200, including the labor, material and patterns.

THE BEST PRACTICES IN ENGINE HOUSE WORK*

BY DAVID E. BARTON

Bonus Supervisor, Atchison, Topeka & Santa Fe, Topeka, Kan.

Every organization which deals with the performance of work depends on the elements of human activity, primarily, physical and mental. The facilities afforded and the conditions prevailing at the time of the performance have much to do with the results obtained.

Engine houses vary in importance as the amount of work done and the number of engines handled, and also with the class of service in which the engines are used. In selecting men for important engine houses the management generally casts about for the successful men at the smaller points. The foreman is selected on account of his ability to get things done right and at the proper time. He must deal fairly with his men and be able to obtain the best results from a given number, and he must also be in perfect accord with the operating officers with whom his organization is dealing. He must have his work so in hand that he will be able to estimate accurately when he can have certain engines ready for service. He must be able to estimate when an engine which is not in the engine house, and perhaps not off its run, will be ready for service if the operating department requires this information. He must be quick to locate troubles which develop and to apply remedies. He must know when a piece of work needs to be done, when it is done right, have a fairly accurate knowledge of the cost of doing it, as well as the time it should require.

He must have the respect of the men who are working under his direction, and he must be interested in the most minute details as well as have a grasp on the whole situation. He must be able to select men who are capable of performing the various classes of engine house work. He must see to it that the various regulations relative to standards of equipment, etc., are lived up to.

He must be familiar with the keeping of such records and the making of such reports as are required, the use of fuel in the engine house, and the issuing of supplies, and he must exercise the best economy. He must be prompt to execute special orders for power, and have a thorough knowledge of the facilities at hand. He must be diligent, patient, and have the power of concentration, as well as capacity for long sustained effort. He must have full knowledge of all the crafts engaged in the work, be familiar with the most approved methods and be able to keep the work going under all conditions.

Specialists should be used on certain work, such as boiler work, valves and valve motion, pistons and guides, rods, driving boxes, etc., and if not available in the shop force they should be developed. He should see that his men maintain the buildings and shop equipment in good condition.

Comfortable working conditions, facilities for the personal comfort of the workmen, such as reading rooms, clean amusements, and something in the line of educational and social ad-

*Entered in the competition on Engine House Work, which closed July 15, 1914.

vantages, will do much to prevent engine failures and keep down the cost of maintenance of power, by keeping workmen in a contented state of mind, resulting in efficiency.

SOME FACTORS IN LOCOMOTIVE MAINTENANCE

BY E. BECKER

Master Mechanic, Chicago & North Western, Escanaba, Mich.

Considering conditions as far back as 1885, when locomotives were painted with drop black, the best kind of varnish was used and all repair work was well done, brings more clearly to mind some of the more important repair items which, if properly taken care of, will assist greatly in keeping power out of the back shops and hospital tracks, and thereby increase the mileage between shoppings.

The care of wedges is one of the most important items. If properly kept up, the wedges not only prevent excessive wear in driving boxes and brasses, shoes and wedges and rod brasses, but do a large share toward avoiding loose and broken cross-heads, broken front cylinder heads and broken frames. If an extra man is placed in charge of this work, the care of driving box cellars and the keeping tight of binder bolts, it will take but a short time to show that these items will relieve the back shop of a large amount of work.

Valve motion should be watched carefully; never allow a "lame" engine to run; close inspection should be made and the trouble corrected. This can be done in any ordinary roundhouse. If necessary close the eccentrics and perhaps apply bushings in the links, transmission bars and hangers

Tire work, rod brass renewals, the babbiting of crossheads, etc., can all be done in roundhouses. Lateral play in trailing and engine truck boxes should also be looked after in roundhouses. In an article in the Railway Age Gazette some time ago, reference was made to increasing the wheel and driving box face to give a larger side bearing and avoid lateral wear. In my opinion this is wrong as it would mean more friction and would be a disadvantage on sharp curves.

Careful inspection should be made of all tires. Good inspectors are valuable assets, and we should be more careful in selecting the men for this important work. Wheels, and especially steel tired engine and tender wheels, should never be allowed to run to the limit as to sharp flanges; this is a dangerous condition in the first place and moreover it then becomes necessary to turn off too much metal from the tread of the wheel in order to again obtain the proper flange. Little or no attention is given to determining why at times one flange out of four in a tender truck becomes sharp. Few roundhouses or shops tram the wheels and square the trucks properly; I have never found four wheels under a tender sharp at one time and if the practice is followed of carefully trammng the wheels to see that the truck is square, I can see no reason why one wheel should become sharp out of four.

Boilers should be washed not less than three times a month, taking water conditions into consideration. I believe that in most places it will be found that there are not enough boiler washers employed. If the matter of boiler washing is kept up it will avoid a great deal of boilermaker's work and help greatly to preserve fireboxes and tubes. A good blow-off system and the free use of soda ash will go far to eliminate scale and mud from boilers. Care should be taken to keep tubes free from soot; they should be blown out at every washout, the brick arch taken down and the tubes canded; the calking edges should be watched very carefully and kept free from burrs.

All tools which are standard should be inspected once every 30 days by a competent man.

The importance of the positions of the various foremen should not be overlooked. These men hold responsible positions and should be selected from the ranks of the best mechanics; they

should have the ability to handle men as well as to direct the work and see that it is properly done, as my experience has indicated that much money is paid out for poor work which has to be done over again. How many foremen personally watch the work to see that it is properly done? Close supervision of details is very desirable and with good judgment and a little common sense, will help materially in the economical maintenance of power.

INDEX HEAD FOR HOLDING ROD BRASSES

BY F. J. DAILY

A jig for holding rod brasses while being finished on a shaper is shown in the illustration. The two parts of the brass are clamped between two circular plates which are pivoted to the vertical face of an angle plate secured to the shaper table. The brass is held securely in place by means of six set screws in the outside circular plate and it has been found that sweating the two parts of

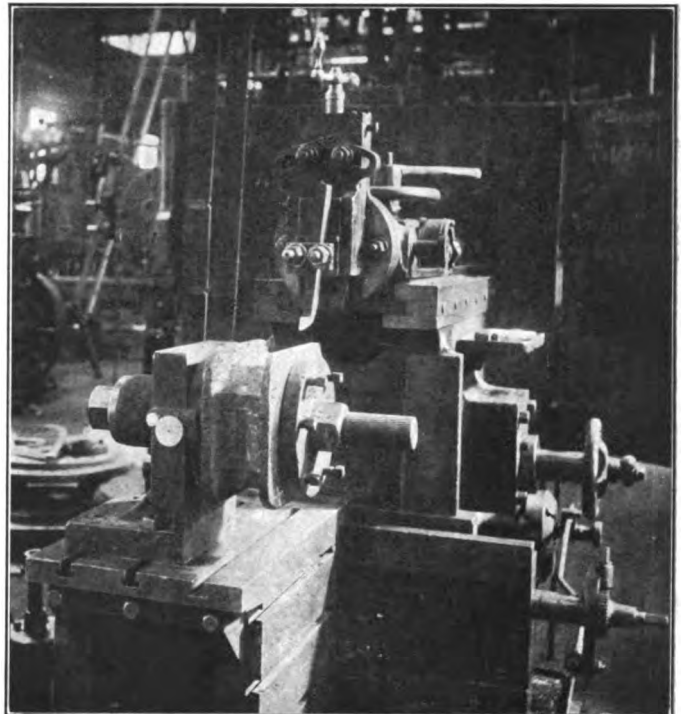

Finishing Rod Brass in Index Head on a Shaper

the brass together is unnecessary. The entire chuck revolves about the axis of the clamping bolt and is fitted with an index head divided into quarters for machining the four sides of the brass. Before chucking the brass the adjoining faces of the two pieces should be finished and the ends faced.

A SPANISH CAR BUILDING PLANT.—The annual report for 1913 of the Spanish Metallic Construction Company, of Madrid, shows that the company's business for the year totaled \$2,888,000, an increase of \$449,100 over 1912. The company has five plants and the number of men employed is 1,800 as against 1,650 in 1912. The chief factory of the five is at Beasain, province of Guipuscoa. This plant alone built during the year 1,250 flat cars and five first-class passenger cars for the Northern Railway; 1,215 freight cars of various kinds, and 43 first-class passenger cars for the Madrid Saragossa & Alicante Railway; 4 first-class and 3 third-class passenger cars for the Oviedo-Hendaye Railway, besides a number of cars of various kinds for companies and individuals. This plant has a capacity of 3,000 freight and 200 passenger cars per year.

NEW DEVICES

ROLLER JOURNAL BEARING

A journal box with roller bearings for use in equalized trucks of the pedestal type is shown in the drawings. It was developed by the Anti-Friction Roller Bearing Company, 88 Broad street, Boston, Mass., and is so designed that no lateral movement takes place between the box and the axle, provi-

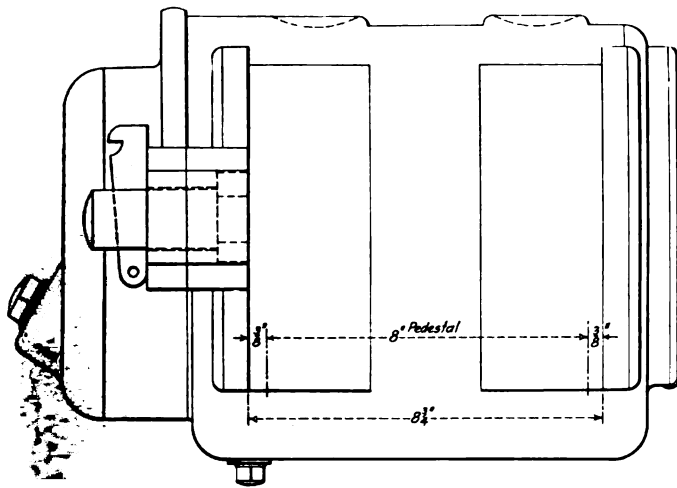

Side Elevation of Roller Bearing Journal Box

sion being made for this movement between the journal box and the truck frame.

The journal box is of cast steel with casehardened roller surfaces and is provided with an oil reservoir in the bottom. In applying the bearings to existing axles the journal is

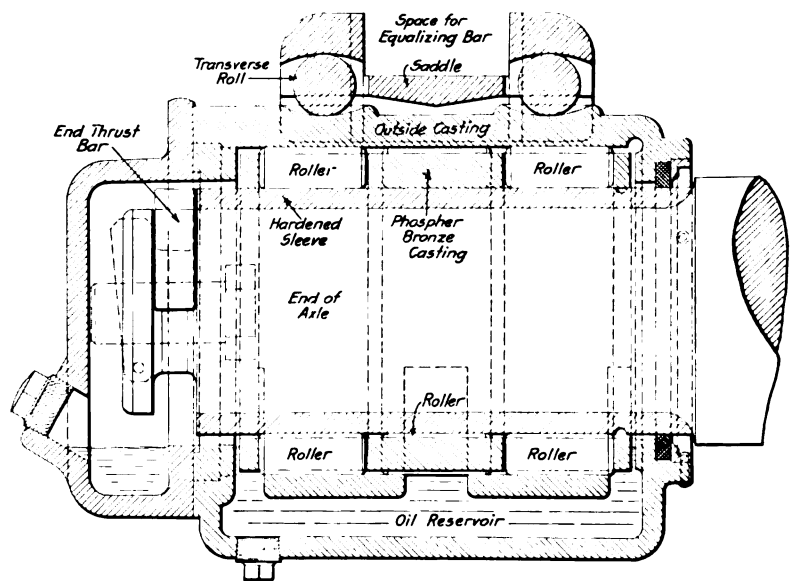
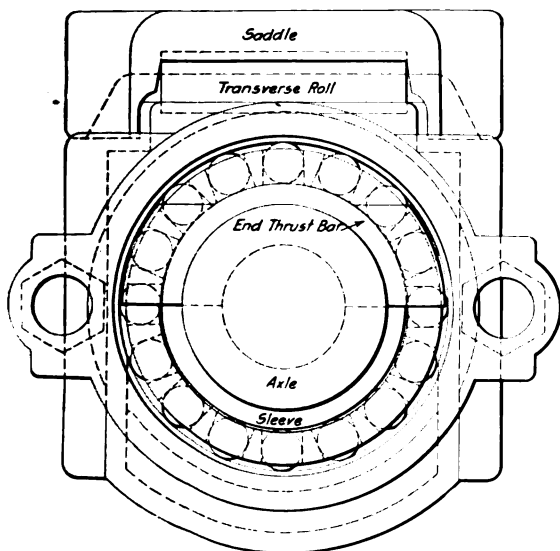

End and Longitudinal Sectional Elevations of Anti-Friction Roller Bearing

turned down as shown in the sectional drawings and fitted with a sleeve of low carbon steel, which is pack hardened on the outside and pressed into place on the journal. The rollers thus run on hardened surfaces and the wear is very slight. The rollers, which are solid, are slipped into slots in a phosphor bronze casing and are divided into three longitudinal sections of 16 rollers each. This construction was

used in order to reduce the trouble from slippage should one end of the journal bearing or of the box wear faster than the other, and it is claimed to have proved successful in operation.

Lateral motion between the journal box and the axle is prevented by an end thrust bar of phosphor bronze. This bar rides in a groove in the end of the axle and at either side projects into pockets in the journal box cover, which are closed at the rear by the face of the box. It may be readily renewed by removing the cover from the box. As shown on the side elevation of the box, the distance between the pedestal flanges is $\frac{3}{4}$ in. greater than the width of the pedestal. This permits the necessary lateral motion of the axle relative to the truck frame, the motion being controlled by the saddle and transverse rollers resting on the top of the box. The saddle is held in position by the end of the equalizer while the rollers provide for the lateral movement of the journal box. The contour of the roller surfaces on the box and on the saddle tends to retain the axle in a central position under normal conditions when running on straight track.

The journal box cover is held in position against the face of the box by two T-bolts and taper keys, which facilitate the quick removal and replacement of the cover for examination or renewal of the bearing. The cover need seldom be removed in service, however, as the bearing may be oiled by removing a plug provided for that purpose. The roller cage is held in place by a forged ring which seats against a shoulder in the end of the box and forms a portion of the cover joint.

Oil is carried in the well in the bottom of the box to such a height that the rollers dip as they revolve and carry the oil to all parts of the bearing. A felt washer, secured at the rear end of the box by a metal ring, keeps the interior free

from dust, and oil is retained by a groove turned in the surface of the journal between the bearing and the end of the box. Service tests indicate that the bearing requires oiling about once in three or four months.

A test to determine the durability of this bearing was conducted during a period of about 18 months on a 50-ton passenger car originally fitted with 5 in. by 9 in. journals. Dur

ing the test the bearings made about 80,000 miles and ran approximately 20,000 miles on one oiling. At the end of the test the rollers, sleeves and other parts of the bearings had acquired a high polish, but are claimed to have shown no other evidences of wear. Repacking the box and renewing brasses being entirely eliminated, the cost of maintenance was reduced to the occasional oiling of the bearings.

HYDRAULIC PIPE BENDER

The engraving shows a press which was primarily designed for bending pipe of various sizes but which is also suitable for miscellaneous work, such as bending small structural shapes, straightening bars, shafts, etc. It is provided with clamps by which it may be attached to a stanchion, the diameter of which is not over 5 in., and it will bend pipe up to 4 in. in diameter.

The press is of steel throughout. The frame and bending bed are cast in one piece; the top of the frame is provided with a ring in which the cylinder sets. The construction is such that the cylinder may be turned to any desired position in the ring and keyed in place, thus bringing the handle of the ram pinion to the point most convenient for the operator. The bending blocks are held in position on the base by means of serrations which interlock with corresponding serrations on the surface of the base, and are readily changed without the use of a wrench.

The ram is forced downward by a hand-operated pump of which the reservoir forms a part. The pump has a plunger diameter of $\frac{5}{8}$ in., and a stroke of $3\frac{1}{2}$ in., and is equipped with a $\frac{1}{2}$ in. safety valve and $\frac{1}{2}$ in. tee wheel operating valve. A hand-operated pump is especially desirable on a press of this

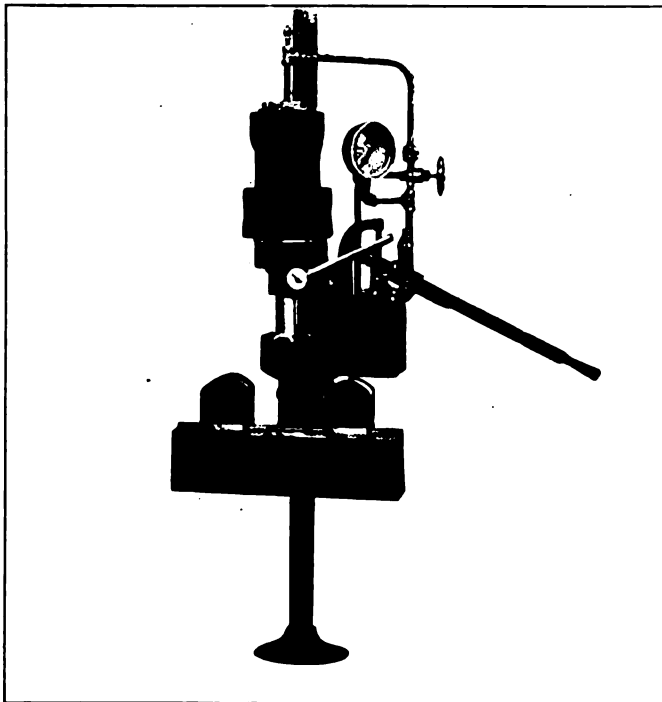

Hand-Operated Hydraulic Pipe Bender

kind because the facility with which the ram pressure may be controlled greatly reduces the danger of over-bending the material. A rack and pinion is provided for the rapid movement of the ram to the work before the pump is operated. As the ram moves downward the cylinder fills with liquid, the upward movement returning the liquid to the water box. There is thus no lost motion in the operation of the pump.

The ram has a diameter of 6 in. and a run of 9 in. The

pressing bed which receives the bending blocks is 27 in. long and has a pressing width of 8 in. The clear height between the ram head and pressure bed is $14\frac{1}{4}$ in., and the height of the press over all is 3 ft. 11 in. It is manufactured by The Hydraulic Press Manufacturing Company, Mount Gilead, Ohio, and develops a maximum pressure of 30 tons.

VERTICAL BAND SAW FOR METAL CUTTING

The metal band saw shown in the illustration cuts at any angle and has been developed by M. E. Shinn & Co., 1846 West Lake street, Chicago. The cutting portion of the blade operates vertically and is automatically fed by gravity, the angle of the saw blade remaining unchanged as the cut progresses.

The material is supported on a table provided with a radial back and a vise operating in a slot across the table. By adjusting the radial back material may be cut at any angle desired. The lug shown at the right end of the radial back is secured

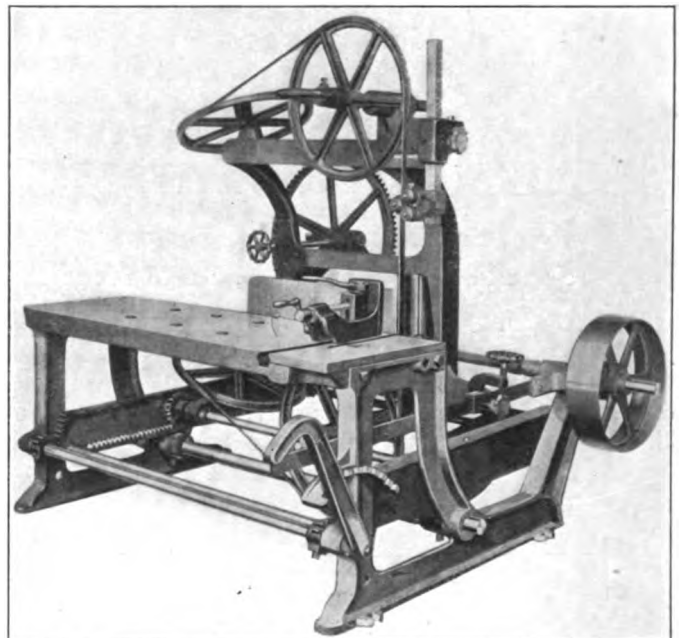

Gravity Feed Metal Band Saw

to the table by a single cap screw, so that it may be readily removed, thus leaving the table clear for the handling of longitudinal work. Any length of work may be handled longitudinally, as there is a clearance of eight inches between the saw and the arbor frame.

The non-cutting or return part of the blade passes over wheels arranged to carry it back to a point where it will clear the material being cut, while the cutting part of the saw is held in a vertical position and is free from twists. The saw arbor is mounted upon four ball bearing wheels, to one pair of which gears are attached. The wheels travel in channels which keep the arbor in alinement as it is fed into the work, and the gears operate in racks which insure uniform travel of both sides of the arbor. The feed is effected by inclining the plane of the channels. The inclination of the tracks may be altered by an operating lever at the right side of the machine and the feed thus regulated to suit the thickness of the work. The action of the saw is entirely automatic; a trip which may be adjusted to any width of material stops the saw after the cut is completed.

This machine is capable of taking material up to 11 in. by 12 in. in section. At ordinary operating speeds it will cut off cold

rolled steel shafting 2½ in. in diameter in about three minutes, while a 6-in. shaft requires about 23 minutes. The band saw used is 15 ft. 6 in. long, ⅝ in. wide and .0312 in. in thickness. The table is 42 in. long and is 18 in. from the floor, a low table being used in order to facilitate the handling of heavy material. The machine shown in the illustration is designed for a single belt drive, but a back geared motor drive can be applied if desired.

AUTOMATIC NUT TAPPING MACHINE

An automatic nut tapping machine using a bent tap to provide for continuous operation without reversing the direction of the tap is shown in the accompanying illustration. This machine was developed by the National Machinery Company, Tiffin, Ohio, and is being built in sizes to handle ¼ in., ⅜ in., ½ in. and ¾ in. nuts.

The hopper in which the blanks are placed is of large size, being designed to hold about 80 lb. on the smaller size machines. The nuts are moved from the hopper to the feed chutes by means of a vane type feed mechanism and are carried down the chute by gravity into position against the starter. There are four of these feed vanes and they are so enclosed that the weight of the blanks does not interfere with their operation. They are driven by a ratchet and pawl from the driving shaft. The ratchet is

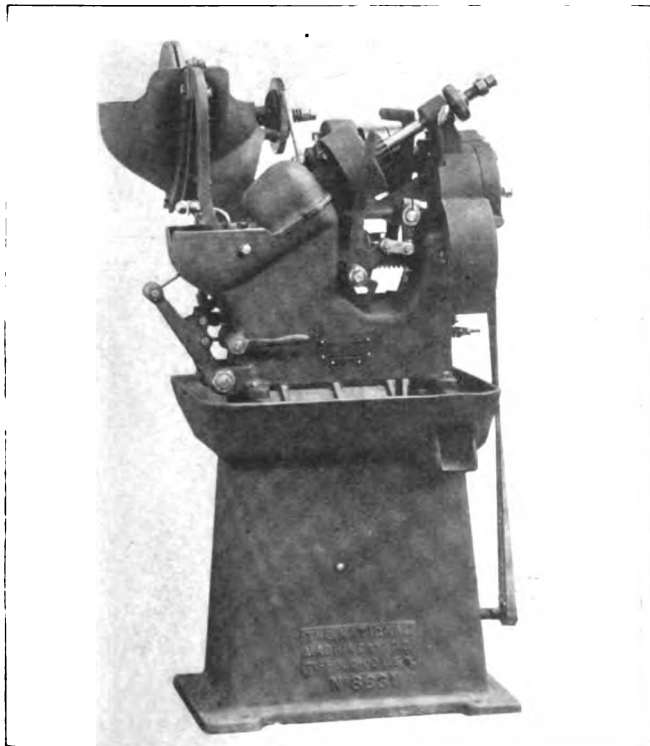

Automatic Nut Tapping Machine in Which a Bent Tap is Used

held between friction flanges which allow it to slip in case thin blanks wedge in the feed groove and interfere with the movement of the vanes, thus preventing damage to the machine.

The tap spindle and starter are inclined, thus causing the face of the blank to lie against the starter. The lubricant keeps the face of the starter washed free from chips so that the blank is always tapped at right angles with the bearing face. After the nut has been started on the tap it is held stationary and the spindle is fed into it during the completion of the operation. By thus holding the nut the difficulty due to binding in the guides, which is often experienced where the nut is fed onto the tap, is overcome. The tap spindle has a slight lateral travel and is counterbalanced, giving the spindle a floating movement.

After the nut has been tapped it travels up the shank, through

the head and off the end of the tap, as shown in one of the illustrations. The hood over the head serves to direct the nuts into a chute by which they are conveyed out of the machine into kegs or boxes. An automatic belt-shifting device is provided by which the machine is stopped in case a slug or an improperly shaped blank should pass over the tap and jam against the head.

These machines are designed primarily for tapping square nuts, but hexagonal nuts can be handled. Each size of machine may be arranged for handling both styles of nuts, as well as

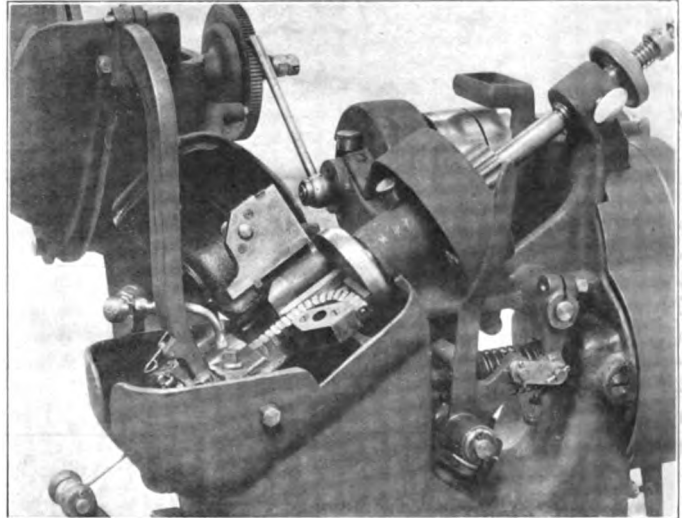

Head of Automatic Nut Tapping Machine Opened, Showing Course of Finished Nuts

several sizes, and by making a simple gear change the rate of feeding can be regulated to suit the kind of nuts being tapped. The ⅜ in. size machine is recommended for operation at the rate of 30 United States standard nuts per minute.

CAR WHEEL GRINDER

The illustration shows a car wheel grinding machine which has recently been developed to handle either steel or cast iron wheels which may be centered either on dead centers or on their own axle journals, as desired. It is manufactured by the Springfield Manufacturing Company, Bridgeport, Conn. Wheels

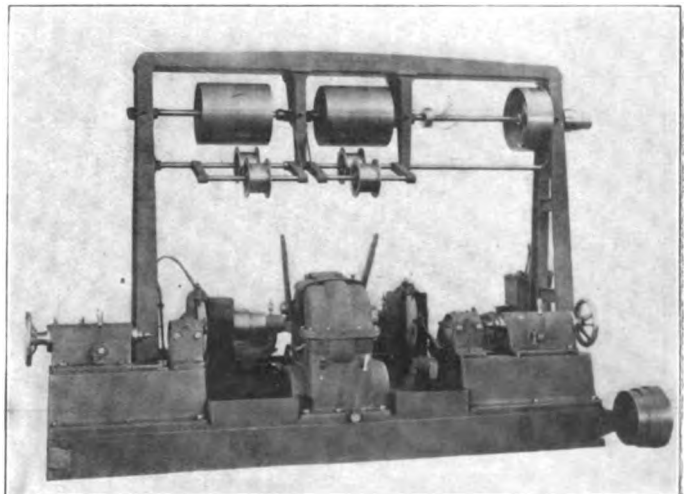

Self Contained Car Wheel Grinding Machine

of any diameter from 28 in. to 44 in. may be handled and provision is made for centering journals up to 6 in. in diameter.

The machine is self-contained and is driven by one belt, either

from a line shaft or by a motor mounted on the base. The countershaft is mounted on a frame which is placed in front of the machine in order that the space directly above the centers may be unobstructed.

The axle is driven by a gap gear at the center from two driving pinions which are widely spaced to overlap the gap in the driven gear. Both pinions are driven by the same shaft in order to insure correct relative action at all times. A clutch which is operated by hand levers from either side of the machine facilitates stopping the axle accurately when the gap in the gear is properly located to permit the removal of the axle. Three different axle speeds are obtainable.

The grinding wheel spindles are driven by a belt from drums on the countershaft, the proper belt tension being automatically secured by means of idlers. Cone pulleys on the spindles provide two different speeds for the wheels. The spindle heads slide in swiveling bases which permit of taper grinding. The slide bearings are of the long narrow type and are provided with taper gibs to take up wear. A feed screw of large diameter is used, at the end of which is placed a ball thrust bearing. Both the feed and the transverse are hand operated. Grinding wheels 18 in. in diameter are used, operating at speeds of 1,040 and 1,350 revolutions per minute, the axle being driven at speeds of 4.2, 5.3 and 6.5 revolutions per minute. Water is delivered to the grinding wheels by means of a suitable pump of ample capacity, part of the bed forming the supply tank. Hoods are placed over the wheels to confine the spray.

Large sleeves and feed screws are used in the tailstocks, which are provided with both dead centers and wobble centers. The dead centers are necessary when grinding engine truck wheels and the wobble centers are provided to prevent axles from moving laterally when grinding wheels on their own journal bearings. The journal rests are designed to receive split bushings of varying diameter, each of which is itself adjustable for slight variations in the diameter of journals.

This machine has a capacity of about 20 pairs of 33 in. wheels per 10-hour day, the exact rate depending upon the condition of the wheels and the amount of stock to be removed. When motor-driven a constant speed motor of 20 hp. is required. The net weight, including the motor and accessories, is about 18,000 lb.

FORGED BRAKE BEAM FULCRUM

The brake beam fulcrum shown in the illustration has been developed by the Damascus Brake Beam Company, Cleveland, Ohio, to replace the malleable iron fulcrums now generally used. This fulcrum is a solid steel forging, one end of which is pro-

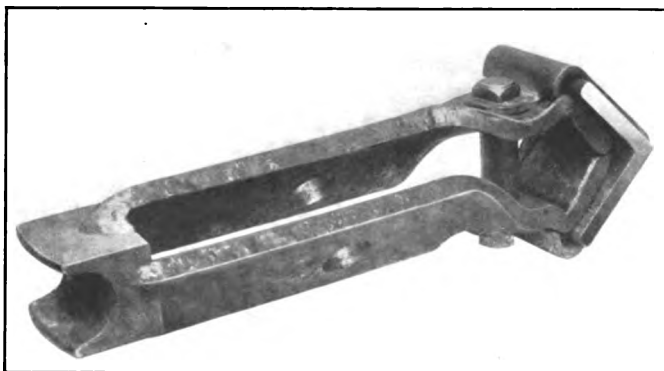

Forged Steel Brake Beam Fulcrum

vided with a seat for the tension member of the beam and the other fitted to the structural compression member. The fulcrum is held in position against the latter by means of a bolt and clamping plate clearly shown in the illustration. As shown, the fulcrum is designed for application to the Anglrod brake beam,

but both the tension and compression member ends may be formed to fit any type of beam.

ADJUSTABLE FIRE DOOR PEDAL

An adjustable pedal has been developed by the Franklin Railway Supply Company, 30 Church street, New York, for use in

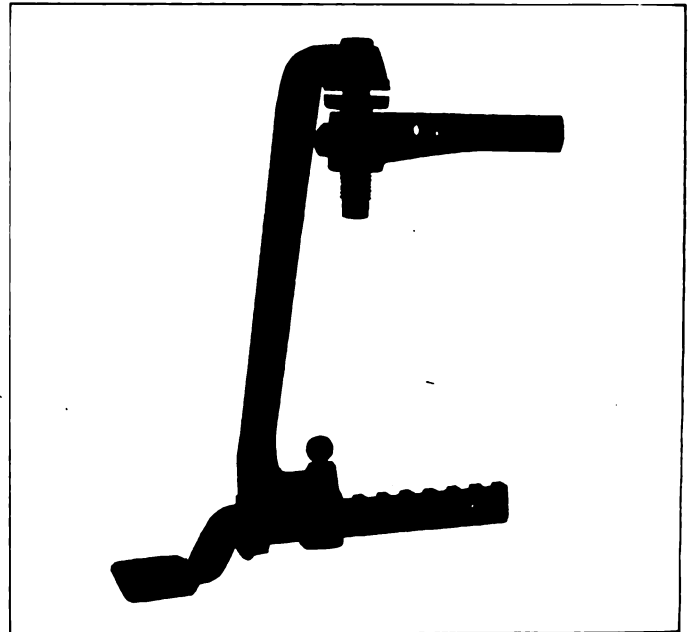

Adjustable Fire Door Pedal Removed from the Door

operating pneumatic fire doors. The tread is mounted in a pedal hanger in which it has a sliding adjustment to permit

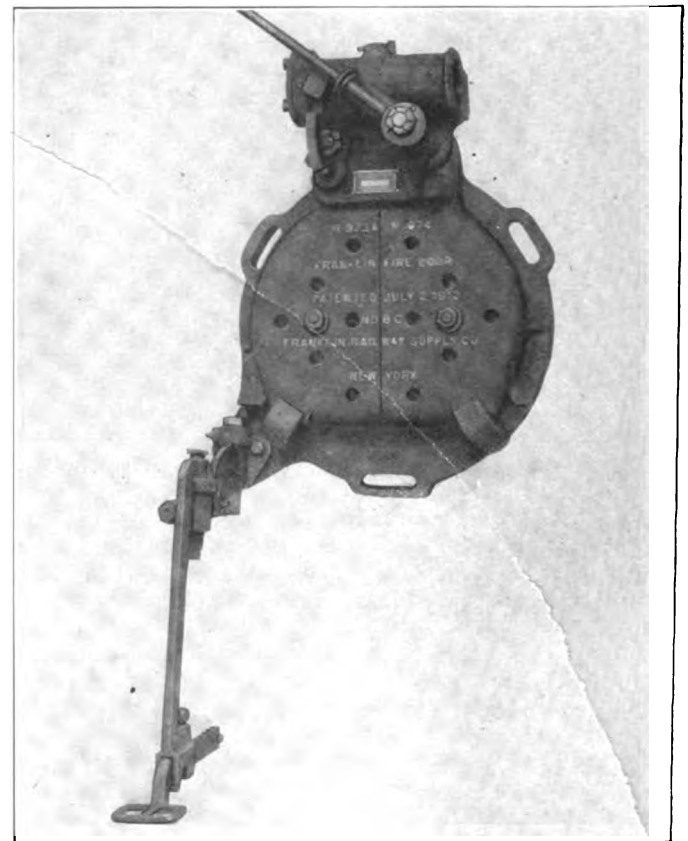

Adjustable Pedal Attached to the Franklin Butterfly Door

moving it farther from the boiler head as the coal is used out of the tender. The tread may also be adjusted for either a tall or a short fireman, a lock being provided which holds it in any desired position. The hanger is mounted on a rigid hanger bolt about which it may be swung in either direction by raising it to clear the teeth in the face of a shoulder on the bolt. When swung to the desired position it is secured by dropping it into place, the teeth in the hanger engaging those in the shoulder. Vertical adjustment of the hanger is provided so that in case of a warped deck the tread may be raised to the proper clearance, making it unnecessary to take the hanger to the blacksmith shop. This adjustment is made by turning the rigid hanger bolt, which is threaded in the fulcrum. One side of the fulcrum is slotted and when the proper adjustment has been made the bolt can be locked in place by means of a bolt provided for that purpose.

PNEUMATIC PLATE FLANGING CLAMP

The accompanying illustration shows a plate flanging clamp on which the clamping beam is not only raised and lowered by air pressure, but also clamped by this means. The machine is built by the Niles Bement Pond Company, New York. On previous designs the top beam was elevated by air pressure, but it was clamped by means of screws with hand-wheels.

The upper beam is moved by four cylinders. There are two lower and two upper pistons, the lower ones being used for elevating and lowering and the upper ones for clamping the beam. These operations are all controlled by means of a three-way valve. The corresponding cylinders are designed to operate simultaneously. The upper beam is held in machined slots in

exert an effective pressure of 15 tons at an air pressure of about 80 lb. per square inch.

SAFETY HOSE CLAMP

The hose clamp shown in the illustration was originally developed for use with its oil burning equipment by the Mahr Manufacturing Company, Minneapolis, Minn., and was in-



Clamping Sleeve Used in Safety Hose Clamp

tended to eliminate the danger arising from failure of the type of clamp now generally used. These clamps are made for all sizes of hose and provide a safe coupling for use with

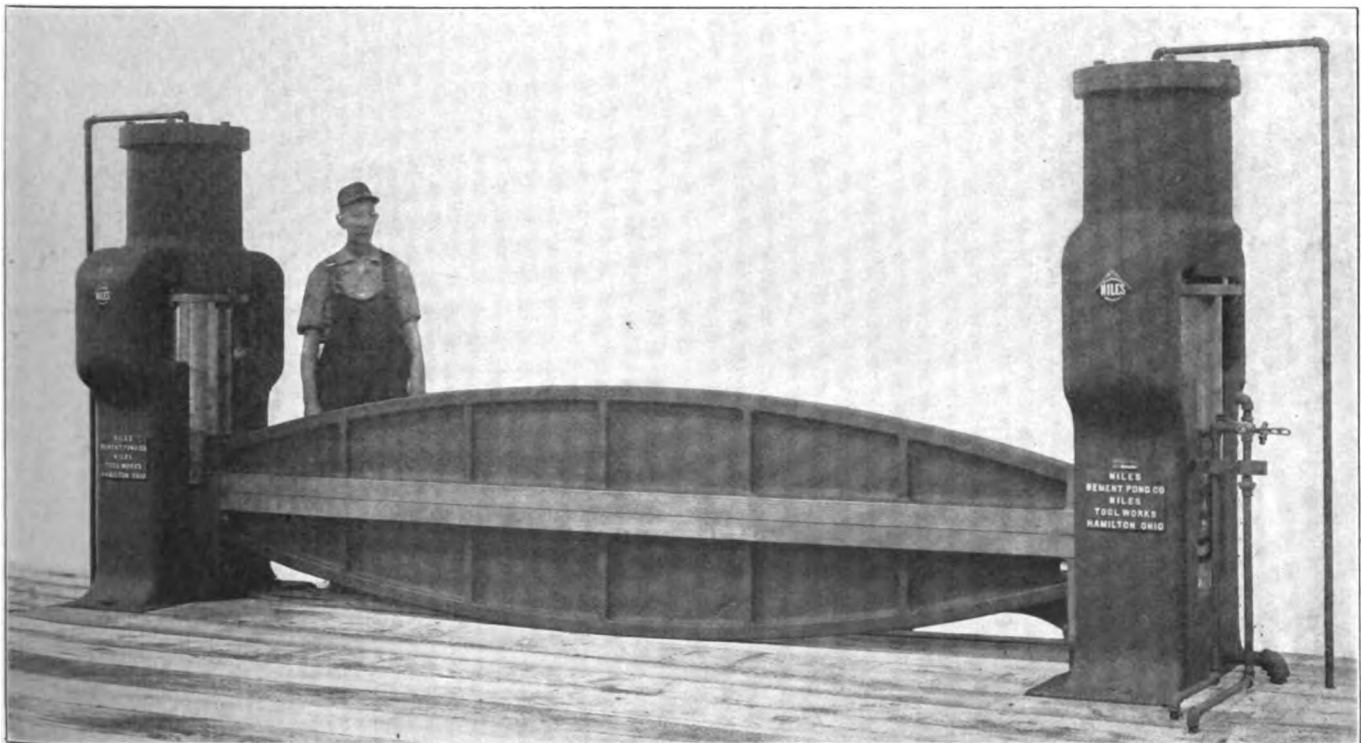

Pneumatic Plate Flanging Clamp

the upper pistons, and means are provided so that the top beam adjusts itself to give an even distribution of the load, when clamping plates of uneven thickness. The upper pistons have a bearing in the frame which prevents any side motion of the pistons and upper clamping beam.

This machine is furnished in several sizes, the one illustrated having a capacity for plates 12 ft. wide. The clamping cylinders

oil, steam or hot water hose, where a failure of the coupling is dangerous.

By referring to the sectional elevation of the coupling it will be seen that a nipple having a knob on the end extends into the hose which is surrounded by a wide spirally-split clamping sleeve, beveled on each end. The beveled surfaces are brought into sliding contact with corresponding concave

surfaces in the body of the coupling at one end and in the clamping nut at the other by screwing the clamping nut on the body of the coupling. The resulting closure of the sleeve

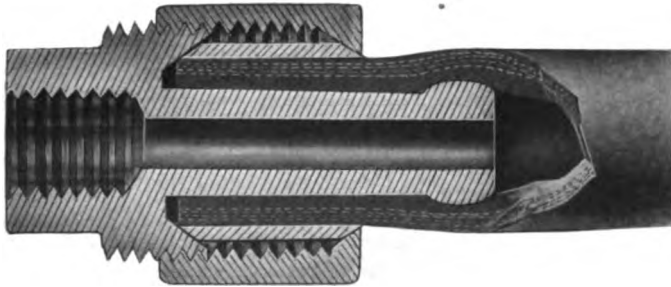

Section Through Hose Clamp Showing Method of Gripping the Hose

effects a firm grip on a considerable length of the hose and practically eliminates the danger of failure from slipping of the joint.

TRIPLEX HYDRAULIC PUMP

A motor-driven triplex single-acting pump which embodies several special features has been added to its line of high-pressure hydraulic pumps by the Watson-Stillman Company, 50 Church street, New York. While primarily designed to meet the requirements of tunnel service it is equally adaptable to other classes of work.

To secure compactness and rigidity the motor is mounted on an extension of the heavy cast iron base. This also insures perfect alinement between the motor and the pump. The pump body is a machine steel forging fitted with bronze valves and bonnets, and is designed to eliminate all air spaces. The passage-

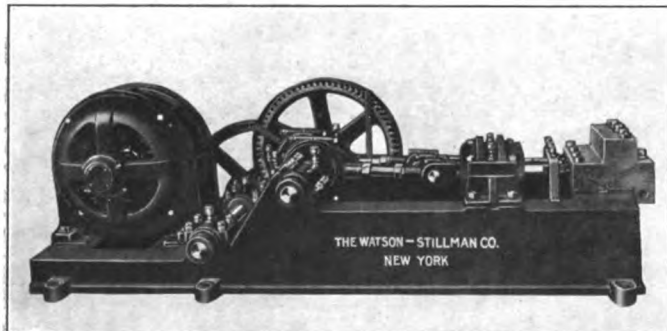

Motor-Driven Hydraulic Pump

ways are made large to reduce friction of the water to a minimum. The plungers are of tool steel and are guided in a rigid crosshead guide which is keyed and bolted to the base. They are driven by eccentrics which are cast in one piece and keyed to the driving shaft, the eccentrics being spaced 120 deg. apart. The driving shaft and bearings are of large proportion and are provided with ample lubrication. The power transmission gears are heavy and have cut teeth throughout. The pump as shown is operated by a 10-hp. motor running at 600 R. P. M. and delivers 100 cu. in. of water per min. at a pressure of 3,500 lb., the speed of the crank shaft being 100 R. P. M.

RUSSIAN BATH TRAIN FOR THE FRONT.—It is stated that the Russian ministry of ways and communications is sending to the front a bath train of over 20 cars, providing 2,000 baths daily. There is a tank car in case water is unobtainable at any stopping place. Soldiers can be given clean underclothes from the stores carried. There is also a car for drying and disinfecting outer garments and a restaurant car.

SAND BLAST HELMET

In the accompanying illustration is shown a helmet which is designed to protect the eyes, face and head of the operator of a sand blast machine from dust and flying sand. The helmet



Sand Blast Helmet

is made of brown canvas, is strongly constructed and is comfortable to wear. As shown in the illustration the rim projects well beyond the operator's face, thus enabling him to turn his head freely without coming in contact with the curtains, which are of sufficient length to descend over the shoulders and effectively exclude sand and dust. The construction is such that there is free circulation of air around the head between the sweat band and the body of the helmet.

Ventilation is facilitated by the eye piece which is usually made of fine wire netting that does not impair the vision and is not affected or dimmed by the action of the flying sand or by dampness, as is glass.

When so desired, however, a celluloid strip may be substituted for the wire gauze, but as a rule this is not recommended. The helmet is manufactured by J. M. Betton, 26 Park Place, New York.

HEAVY DUTY UNIVERSAL MILLING MACHINE

In the accompanying illustrations is shown a universal double back geared milling machine designed for heavy duty, which has been recently introduced by the Rockford Milling Machine Company, Rockford, Ill. This machine is of the knee type, with an especially rigid overhanging arm and a vertical brace for the outer end of the arbor. It is driven by a 3 in. double belt on a three step cone pulley.

The spindle runs in phosphor bronze bearings which are provided with means for taking up the wear of both bearings in one operation. The spindle is 3 in. in diameter. It is fitted with a Brown & Sharpe No. 11 taper socket and a 1 in. straight hole extending through to the end of the spindle.

The spindle speeds are in geometrical progression, ranging from 17 to 392 r. p. m. in either direction. The double back gears are enclosed in the column and placed at the front of the machine. This arrangement brings the gears close together, and is claimed to prevent chatter when taking heavy cuts. All gears are of liberal diameter with wide surfaces and coarse pitch.

The table has a working surface of 50 in. by 11½ in. It is provided with quick return motion and is designed to swing through an arc of 300 deg. The table feed gearing is driven by a chain which is enclosed in the column to protect it from dust. The feed changes are 14 in number, ranging from .005 in. to .175 in. per revolution of the spindle. Only two levers are required to make all feed changes. The maximum length of automatic feed is 28 in. for longitudinal, 8 in. for the cross feed

and 19 in. for the vertical feed. If desired, however, the machine may be specially provided with longitudinal and vertical feeds of 34 in. and 20 in. respectively.

The overhanging arm is of solid steel 4 in. in diameter and is provided with two bronze bushed arbor supports. It is held

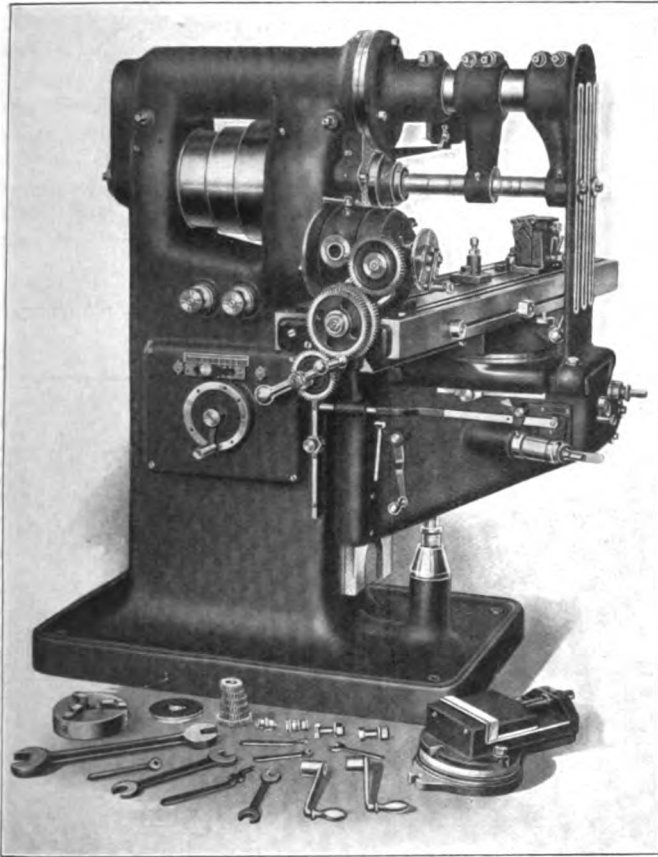

Double Back Geared Universal Milling Machine

in position by a flanged support which is secured to a solid flange on the face of the column.

The vertical milling attachment, which is shown in one of the illustrations, is not driven through the main spindle nose as is usual in knee type milling machines. When placing the attach-

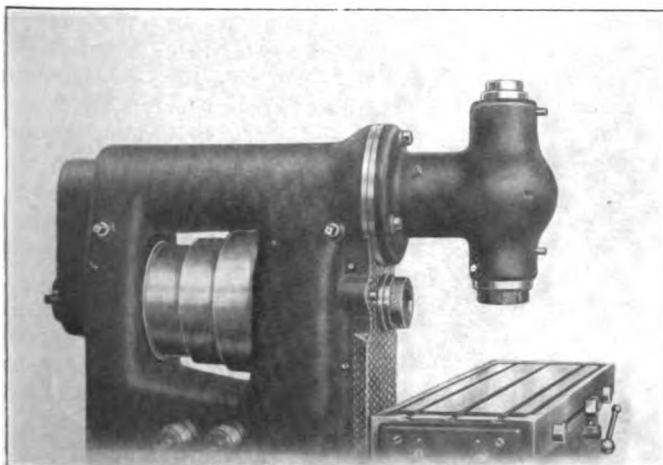

Vertical Milling Attachment in Place

ment on the machine the overhanging arm is removed and a sleeve in which runs a driving shaft inserted in its place. The attachment is clamped to the flange on the main column and its spindle driven by the shaft, through beveled gears which form

a part of the attachment. The shaft is driven through a geared connection back of the main spindle, by the use of an idler gear. This arrangement provides the same range under the vertical attachment as is permitted under the main spindle, and also leaves the main spindle free for use on certain kinds of work without dismantling the attachment or removing work from the table, it being only necessary to turn the lower arm of the attachment out of line with the main spindle.

The machine is provided with a spiral dividing head which will swing 10½ in. in diameter and take 24 in. between centers. Its spindle can be set at any angle from 10 deg. below horizontal to 10 deg. beyond perpendicular. A vise attachment having a graduated swivel base and a maximum opening of 3½ in., as well as a three-jaw chuck 6 in. in diameter are also included in the equipment of the miller. The net weight of the machine is 3,800 lb.

PNEUMATIC LIGHT FORGING HAMMER

The illustration shows a light forging hammer for operation by compressed air which was designed to handle tool dressing, light bending and straightening, and the miscellaneous forging work which is usually done by a blacksmith and helper. The use of compressed air permits its location at points in the plant where

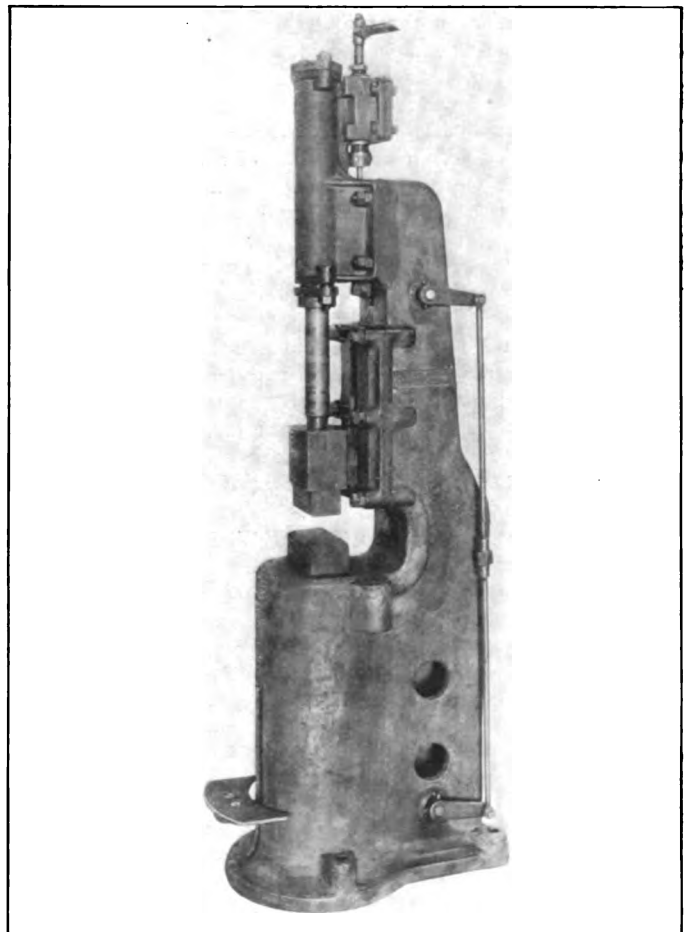

Pneumatic Forging Hammer for Light Work

steam is not available. Air from the shop system at 80 lb. to 100 lb. pressure is used, a ½-inch pipe or hose connection being required.

The heavy anvil block is cast in one piece with the frame to which the cylinder is keyed and bolted, the key extending entirely across the face of the joint. The guides for the ram are also secured to the face of the frame. Side housings were

avoided in the design in order to keep the working space clear and to facilitate observations of the work under the hammer. All important bolts have double nuts to prevent them from jarring loose. The piston and piston rod are formed from one piece of chrome-vanadium steel, oil treated, while the hammer head and guide shoe are made in one piece of high carbon steel. The guide shoe is of large area and the piston rod has a long taper fit in the ram. The dies, which are removable, are of special die steel with hardened faces.

The piston is packed with cast iron snap rings. In order to facilitate the examination and renewal of the rings the piston rod stuffing box gland is split so that it may be readily removed. The piston may then be raised above the top of the cylinder and inspected without the necessity of removing the ram from the piston rod.

The plain forging dies shown in the illustration are regularly furnished with the hammer, but special dies of any form may be quickly substituted. For accurate die work, such as forming and stamping light sheets, the anvil is furnished with three heavy cast lugs spaced 120 deg. apart. These are fitted with hardened centering screws by means of which the lower die may be accurately aligned with the upper one. In order to provide clearance for the work the frame is recessed at the top of the anvil and the front and back walls are removed, thus permitting the passage of long stock through the frame when it is desired to work the stock across the die.

The air admission to the cylinder is controlled by a simple slide valve designed to remain tight regardless of wear, and provided with special ports to give the control desired. The valve is operated by the foot lever shown at the front of the anvil. This lever is depressed by a slight pressure of the foot and returned to its upper position by the pull of a coil spring located in a pocket at the front of the anvil. When air is admitted to the valve chamber the ram rises to its upper position and on depressing the foot lever it strikes a quick, snappy blow of great force. Upon releasing the lever slightly the ram rises instantly to its upper position, where the piston is air cushioned so that it cannot strike the cylinder head. The hammer readily responds to variations in the foot pressure and it is claimed that with a little practice the range of operation may be varied from light, rapidly repeated blows of short height for use in straightening light material to the maximum force of the hammer, which is sufficient for the reduction of 2-in. stock. The foot control is especially suited to the miscellaneous class of work for which the hammer is adapted.

The hammer is manufactured by H. Edsil Barr, Erie, Pa. An important consideration is its comparative freedom from limitations as to location, being independent both of line shafting and a steam supply. It is built in two sizes, one weighing 800 lb. for light tool and soft metal work, and the other weighing 1,200 lb. suitable for general forging operations on material 2 in. square or smaller. The larger hammer occupies a floor space 14 in. by 24 in. and stands 5 ft. 6 in. high.

TALC AS A LUBRICANT.—A German chemical journal contains an article relating to the use of talc for lubricating purposes. Talc does not behave like graphite when treated with tannin solutions, but it may be brought into a fine molecular state by heating it with ammonium carbonate or by exposing it for several hours to a current of dry ammonia. The talc is afterward dried in a vacuum. The treated material can be suspended in water so that it is very difficult to filter it, and subsides very slowly in lubricating oils of medium density. When once suspended in a neutral oil, the talc does not subside on heating. The change in the character of the talc is attributed to the absorption of a minute quantity of ammonia. From 40 to 60 per cent of ordinary talc may be introduced into heavy mineral oil, provided the oil is added to the talc and the operation not carried on in the reverse manner.—*Machinery*.

MAGNET FOR REMOVING METAL FROM THE FLESH

A magnet for removing metal embedded in the flesh, which is one of the most powerful in the world, has been installed by the Westinghouse Electric & Manufacturing Company in the relief department of its East Pittsburgh works. The magnet is mounted on a box containing the resistor, which is used to regulate the amount of current flowing through the coils. It requires 4,000 watts for its operation, or enough power to supply 100 Mazda lamps of 32 candle power each, and is designed for operation on 70 volts.

It is not an infrequent occurrence for steel and iron workers to get bits of metal in their eyes or hands. Previous to the installation of a magnet the only means of removal was



Magnet in Operation, Removing Steel from the Eye

by probing, a method which is as uncertain as it is painful. Since this machine was put in operation it is a very simple proceeding to extract such particles. The portion of the body in which the foreign particle is embedded is placed near the pole tip of the magnet, the switch is closed, and the magnet does the rest. Some remarkably small pieces have been extracted in this way. The pole piece is removable, a number of different shapes being supplied for various classes of work.

MACHINE POWER AND PIECEWORK.—In any shop if the feeds, speeds and power of machine tools of the same class vary, it is a practical impossibility to establish a just and efficient piecework or premium system.—*American Machinist*.

MATERIALS FOR CASEHARDENING.—The composition of case-hardening materials varies very widely. The following table shows the range of variation in seventeen commercial compositions tested:

	Per Cent
Moisture	2.68 to 26.17
Oil	0.17 to 20.76
Carbon (organic)	6.7 to 54.19
Calcium phosphate	0.32 to 74.75
Calcium carbonate	1.2 to 11.57
Barium carbonate	nil to 42.0
Zinc oxide	nil to 14.5
Silica	nil to 8.14
Sulphates (SO ₃)	trace to 3.45
Sodium chloride	nil to 7.88
Sodium carbonate	nil to 40.0
Sulphides (S)	nil to 2.8

—*Machinery*.

NEWS DEPARTMENT

E. B. Roberts, smoke inspector of the city of Cleveland, has submitted a report showing that the density of locomotive smoke during the second half of 1914 decreased 79 per cent, as compared with the second half of 1912.

A press despatch from Vera Cruz, Mexico, February 2, announced the re-opening of the railroad between that place and Mexico City, with a passenger train running through for the first time since November 19.

The Chicago & Alton has reached an agreement with a committee representing its trainmen, providing for increases in pay for flagmen and train baggagemen, and a number of changes in working conditions, including payment for terminal overtime, and extra payments for work outside of the regular routine.

Representatives of the conductors', trainmen's, enginemen's and firemen's unions, in Ohio, have announced that they will concentrate their efforts before the legislature this year on the effort to secure the passage of the train limit bill and to oppose the repeal of the extra crew law, but will urge no other anti-railroad legislation.

A bill has been introduced in the Missouri legislature to require interstate railroads to establish stations not more than five miles from the state line, to put an agent in charge and to stop trains long enough to enable passengers to buy new tickets and have their baggage rechecked, in order to take advantage of the lower intrastate passenger fares.

The Secretary of the Interior has recommended to Congress an appropriation of \$2,000,000 for the use of his department in the work of building the proposed government railroad in Alaska. An appropriation of \$1,000,000 was made at the last session of Congress. The secretary has not yet reached any decision as to the purchase of the Copper River & North Western or the Alaska Northern, both of which roads may be included in the proposed government system.

H. W. Thornton, formerly general superintendent of the Long Island Railroad, now general manager of the Great Eastern of England, has "made good." This statement came in a recent press despatch from London, saying that at the annual meeting of the shareholders of the Great Eastern, Lord Claud Hamilton, the chairman of the company, paid Mr. Thornton a special tribute; and that the meeting unanimously agreed that Mr. Thornton, already, before filling out a year's service, had fairly justified his selection as manager.

Five years ago, in co-operation with the Pennsylvania State College, the Pennsylvania Railroad organized its first class of apprentices for school instruction. The school was established at the Altoona shops and 30 pupils were enrolled. Three branch schools have since been opened at other points on the line, and today the total enrollment numbers 300 young men. Thus far, 151 apprentices have completed the full three-year course and

have been graduated from the school; approximately 60 more will be added to this number by the classes going out this year.

The American Museum of Safety, William H. Tolman, director, made its annual award of medals on February 10, at the United Engineering Societies building, 29 West Thirty-ninth street, New York City. The E. H. Harriman Memorial medal for the American steam railroad, which during one year has been the most successful in protecting the lives and health of its employees and of the public, was presented to the New York Central. The Anthony N. Brady medal for a similar purpose, awarded to an electric railway, went to the Boston Elevated.

The railroad committees of the house and senate of the Kansas legislature held a hearing on February 1, on the extra crew, the train limit and other bills affecting railroads and their employees. Officers of the railroads and representatives of the employees appeared and presented arguments. All of the employees' representatives favored the bills, except a negro porter, representing the porters, who opposed the extra crew bill, on the ground that if an extra brakeman or flagman were required on passenger trains the elimination of the train porters would follow. A. De Bernardi, general superintendent of the Missouri Pacific, said that if the bill were passed, for every extra brakeman added it would be necessary for many roads to lay off two trackmen as a measure of economy, and that the trackmen were more essential to safety than the extra brakeman. Representatives of the roads also brought out the fact that the trainmen had never attempted to negotiate with the officers of the roads for extra brakemen.

A TALK TO APPRENTICES

On February 15, George M. Basford, chief engineer of the railroad department of Joseph T. Ryerson & Son, made an address before the apprentices of the Chicago & North Western at Chicago. The talk was intended to give the boys a bigger and broader view of the opportunities which lay before them and of the possibilities which might result if they were to follow their work in the right spirit. The title of the address was "Making Heroes." "Choose to be heroes," said Mr. Basford, "in the heroism of simple honesty in the work which shows and in that which lies concealed, that you may look back in years that are to come, proud that you have done an important part in making the Chicago & North Western a better railroad. To see what is right and not to do it, is want of courage." The address was enthusiastically received.

A. S. M. E. BOILER CODE

The boiler code committee of the American Society of Mechanical Engineers has made a final report on this subject, which has been accepted by the council. This final report is the result

RAILROAD CLUB MEETINGS

Club	Next Meeting	Title of Paper	Author	Secretary	Address
Canadian	Mar. 9	Railway Advertising	Edward Hungerford..	James Powell....	St. Lambert, Que.
Central	Mar. 11	Rules of Interchange	Committee Report...	Harry D. Vought...	95 Liberty St., New York.
New England....	Mar. 9	Annual Meeting	Wm. Cade, Jr....	683 Atlantic Ave., Boston, Mass.
New York.....	Mar. 19	Annual Electrical Night	Harry D. Vought...	95 Liberty St., New York.
Pittsburgh	Mar. 26	Rules of Interchange	Committee Report...	J. B. Anderson....	207 Penn Station, Pittsburgh, Pa.
Richmond	Mar. 8	Railways and Agricultural Development...	F. H. La Baume....	F. O. Robinson...	C. & O. Ry., Richmond, Va.
St. Louis	Mar. 12	Relations of Wage Payments	F. H. Hamilton....	B. W. Frauenthal.	Union Station, St. Louis, Mo.
South'n & S'w'rn.	Mar. 18	Methods of Wage Payments	R. E. Smith, C. Pierce
Western	Mar. 16	and Stores Departments	and W. D. Stokes..	A. J. Merrill....	Box 1205, Atlanta, Ga.
Western Canada..	Mar. 8	Fuel Oil in Extreme Climates.....	Frank McManamy...	Jos. W. Taylor....	1112 Karpen Bldg., Chicago, Ill.
			J. G. LeGrand.....	Louis Kon	Box 1707, Winnipeg, Man.

of the work of the original committee, of which John A. Stevens is chairman, and an advisory committee consisting of engineers representing various phases of the design, installation and operation of boilers. This advisory committee included the following representatives from the railway field: F. H. Clark, general superintendent of motive power of the Baltimore & Ohio; A. L. Humphrey, vice-president and general manager of the Westinghouse Air Brake Company; H. H. Vaughan, assistant to vice-president, Canadian Pacific Railway, and W. F. Kiesel, Jr., assistant mechanical engineer of the Pennsylvania Railroad. The code is considerably shorter than when originally brought out by the committee; and the rules laid down in it, of course, do not apply to boilers which are subject to federal inspection and control. The original committee and the advisory committee have been continued as one and will meet once a year in order to make any changes that advances in practice may make necessary. At these meetings will also be taken up any change which may seem necessary in a rule because it works unnecessary hardship on any particular class of boiler makers or users.

MEETINGS AND CONVENTIONS

American Society for Testing Materials.—The eighteenth annual meeting of the American Society for Testing Materials will be held at the Hotel Traymore, Atlantic City, N. J., on June 22-26, 1915.

Air Brake Association.—The twenty-second annual convention of the Air Brake Association will be held at the Hotel Sherman, Chicago, Ill., Tuesday, May 4, 1915. Committees will report on the Accumulation of Moisture and its Elimination from Trains and Yard Testing Plants, Adequate Hand Brakes on Heavy Passenger Equipment Cars, Need of Efficient Cleaning and Repairing of Freight Brakes, What Shall We Do to Improve the Present Pneumatic Signal Device, Difficulties the Railroad Companies Encounter in Endeavoring to Run 100 Per Cent Operative Brakes in Freight Service, and M. C. B. Air Brake Hose Specifications.

The following list gives names of secretaries, dates of next or regular meetings, and places of meeting of mechanical associations.

AIR BRAKE ASSOCIATION.—F. M. Nellis, 53 State St., Boston, Mass. Convention, May 5-7, 1915, Hotel Sherman, Chicago.

AMERICAN RAILROAD MASTER TINNERS, COPPERSMITHS AND PIPEFITTERS' ASSOCIATION.—W. E. Jones, C. & N. W., 3814 Fulton street, Chicago. Annual meeting, Chicago.

AMERICAN RAILWAY MASTER MECHANICS' ASSOCIATION.—J. W. Taylor, Karpen building, Chicago. Convention, June 9-11, 1915, Atlantic City, N. J.

AMERICAN RAILWAY TOOL FOREMEN'S ASSOCIATION.—Owen D. Kinsky, Illinois Central, Chicago. Convention, July 19-21, 1915, Hotel Sherman, Chicago.

AMERICAN SOCIETY FOR TESTING MATERIALS.—Prof. E. Marburg, University of Pennsylvania, Philadelphia, Pa. Convention, June 22-26, 1915, Hotel Traymore, Atlantic City, N. J.

AMERICAN SOCIETY OF MECHANICAL ENGINEERS.—Calvin W. Rice, 29 W. Thirty-ninth street, New York. Annual meeting, December 7-10, 1915, New York.

ASSOCIATION OF RAILWAY ELECTRICAL ENGINEERS.—Joseph A. Andreucetti, C. & N. W., Room 411, C. & N. W. Sta., Chicago. Annual meeting, October, 1915.

CAR FOREMEN'S ASSOCIATION OF CHICAGO.—Aaron Kline, 841 North Fifthieth Court, Chicago; 2d Monday in month, except July and August, Lytton building, Chicago.

CHIEF INTERCHANGE CAR INSPECTORS' AND CAR FOREMEN'S ASSOCIATION.—S. Skidmore, 946 Richmond street, Cincinnati, Ohio.

INTERNATIONAL RAILWAY FUEL ASSOCIATION.—C. G. Hall, 922 McCormick building, Chicago. Convention, May 17-20, 1915, Chicago.

INTERNATIONAL RAILWAY GENERAL FOREMEN'S ASSOCIATION.—William Hall, 1126 W. Broadway, Winona, Minn. Convention, July 13-16, 1915, Hotel Sherman, Chicago.

INTERNATIONAL RAILROAD MASTER BLACKSMITHS' ASSOCIATION.—A. L. Woodworth, Lima, Ohio. Convention, August 17, 1915, Philadelphia, Pa.

MASTER BOILER MAKERS' ASSOCIATION.—Harry D. Vought, 95 Liberty street, New York. Convention, May 26-28, 1915, Chicago, Ill.

MASTER CAR BUILDERS' ASSOCIATION.—J. W. Taylor, Karpen building, Chicago. Convention, June 14-16, 1915, Atlantic City, N. J.

MASTER CAR AND LOCOMOTIVE PAINTERS' ASSOC. OF U. S. AND CANADA.—A. P. Darc, B. & M., Reading, Mass. Convention, September 14-17, 1915, Detroit, Mich.

NIAGARA FRONTIER CAR MEN'S ASSOCIATION.—E. Frankenberger, 623 Brisbane building, Buffalo, N. Y. Meetings monthly.

RAILROAD MASTER TINNERS, COPPERSMITHS AND PIPEFITTERS' ASSOCIATION.—U. G. Thompson, C. & E. I., Danville, Ill. Annual meeting, May, 1915.

RAILWAY STOREKEEPERS' ASSOCIATION.—J. P. Murphy, Box C, Collinwood, Ohio. Convention, May 17-19, 1915, Hotel Sherman, Chicago.

TRAVELING ENGINEERS' ASSOCIATION.—W. O. Thompson, N. Y. C. & H. R., East Buffalo, N. Y. Convention, September, 1915, Chicago, Ill.

PERSONALS

It is our desire to make these columns cover as completely as possible all the changes that take place in the mechanical departments of the railways of this country, and we shall greatly appreciate any assistance that our readers may give us in helping to bring this about.

GENERAL

A. R. AYERS, who was general mechanical engineer of the Lake Shore & Michigan Southern and other New York Central lines west of Buffalo with office at Chicago, has been appointed principal assistant engineer of the New York Central, general duties car design and construction, with headquarters at New York.

R. M. BROWN has been appointed assistant engineer, in charge of engineering and drafting at the locomotive and car shops of the New York Central, with headquarters at Cleveland, Ohio.

JOSEPH CHIDLEY, assistant superintendent of motive power and rolling stock of the New York Central, with headquarters at Cleveland, Ohio, now has jurisdiction over the Illinois division.

F. S. GALLAGHER has been appointed assistant engineer, in charge of car design and specifications of the New York Central, with headquarters at New York.

W. B. GEISER, who was acting chemist and engineer of tests of the New York Central & Hudson River at West Albany, N. Y., has been appointed assistant chemist and engineer of tests of the New York Central at West Albany.

P. P. MIRTZ, who was mechanical engineer of the Lake Shore & Michigan Southern at Cleveland, Ohio, has been appointed assistant engineer, in charge of locomotive design and specifications, of the New York Central, with headquarters at New York.

E. F. NEEDHAM, superintendent of the locomotive and car departments of the Wabash, has removed his office from Springfield, Ill., to Decatur.

P. ROQUEMORE has been appointed mechanical engineer of the International & Great Northern, with office at Palestine, Texas.

H. E. SMITH, who was chemist and engineer of tests of the Lake Shore & Michigan Southern at Collinwood, Ohio, has been appointed chemist and engineer of tests, with supervision over laboratories and material inspection, of the New York Central, with headquarters at Collinwood, Ohio.

G. WHITELEY, master mechanic of the Alberta division of the Canadian Pacific, at Calgary, Alta., has been appointed assistant superintendent of motive power of the Eastern Lines, with headquarters at Montreal, Que.

MASTER MECHANICS AND ROAD FOREMEN OF ENGINES

S. T. ARMSTRONG has been appointed master mechanic of the International & Great Northern at Palestine, Tex., succeeding T. Windle, resigned.

E. J. BRYANT, general foreman of the International & Great Northern at Houston, Tex., has been appointed master mechanic at Mart, Tex.

A. F. CASKEY has been appointed road foreman of equipment of the Des Moines Valley division of the Rock Island Lines, and that part of the Dakota division between Valley Junction and Gowrie, with headquarters at Valley Junction, Ia.

A. E. DALES has been appointed district master mechanic of the Canadian Pacific at Brandon, Man., succeeding L. G. Fisher.

L. G. FISHER, formerly district master mechanic of the Canadian Pacific at Brandon, Man., has been appointed district

master mechanic at Cranbrook, B. C., succeeding A. Sturrock, promoted.

J. T. FLAVIN has been appointed master mechanic of the Illinois division of the New York Central at Gibson, Ind.

GEORGE S. GRAHAM has been appointed master mechanic of the Pennsylvania division of the Delaware & Hudson at Carbondale, Pa., succeeding John J. Reid, transferred.

N. M. BARKER, whose appointment as master mechanic in charge of the mechanical and supply departments of the Copper Range Railroad at Houghton, Mich., has been announced in these columns, entered railroad service as a machinist apprentice and was employed as a machinist for several years on western roads, during which time he prepared himself for college. He entered the University of Arizona at Tucson, where he specialized in mechanical engineering, and at the same time was engaged as instructor in machine shop practice. Upon leaving college he again entered railway service as machine shop foreman of the Cerro de Pasco Railway at Cerro de Pasco, Peru, and was later appointed assistant master

mechanic of this road. Mr. Barker left this position to return to the United States, where he again took up railway work, being employed as a draftsman on the Nevada Northern at Ely, Nev. He left this road to become superintendent of construction for the A. Hughes Construction Company, Denver, Colo., and for the past several years has been engaged in this capacity on general engineering work in the West. He severed his connection with this company on his appointment as master mechanic of the Copper Range as above noted.

W. H. KELLER has been appointed assistant master mechanic of the Baltimore & Ohio Southwestern, at Cincinnati, Ohio, succeeding A. E. McMillan.

C. KYLE has been appointed master mechanic of the Atlantic division of the Canadian Pacific at St. John, N. B.

A. E. McMILLAN, assistant master mechanic of the Baltimore & Ohio Southwestern, at Cincinnati, Ohio, has been appointed master mechanic of the Indiana and Illinois divisions, with headquarters at Washington, Ind.

JOHN J. REID, master mechanic of the Pennsylvania division of the Delaware & Hudson at Carbondale, Pa., has been appointed master mechanic of the Susquehanna division, with headquarters at Onconta, N. Y., succeeding William Malthaner.

H. SELFRIDGE, formerly general foreman of the Oregon Short Line at Salt Lake City, Utah, has been appointed master mechanic of the Nevada Northern at East Ely, Nev. Mr. Selfridge was born on July 12, 1872, at Brownsville, Minn., his parents soon afterward moving west and settling in Oregon. After receiving a high school education he became a machinist apprentice in Tacoma, Wash., finishing with a special course of one year in the boiler shop. He then entered the service of the Central Pacific at Sacramento, Cal., as a locomotive fireman. In 1898 he was promoted to engineer, in which capacity he was employed on various divisions of the Southern Pacific

until the fall of 1905, when he left the service to engage in other business. Mr. Selfridge subsequently re-entered railway work, being employed in the locomotive service of the San Pedro, Los Angeles & Salt Lake, the Denver & Rio Grande and the Union Pacific until April, 1907. He then entered the service of the Oregon Short Line as district foreman, and has since been connected with that road in various capacities until his appointment as master mechanic of the Nevada Northern, as noted above.

A. STURROCK, district master mechanic of the Canadian Pacific at Cranbrook, B. C., has been appointed master mechanic of the Alberta division at Calgary, Alta., succeeding G. Whiteley, promoted.

E. B. VAN AKIN has been appointed road foreman of equipment of the Minnesota division of the Rock Island Lines at Manly, Iowa.

A. YOUNG, roundhouse foreman of the Chicago, Milwaukee & St. Paul, at Chicago, has been appointed district master mechanic at Milwaukee, Wis.

W. MALTHANER, whose appointment as master mechanic of the Baltimore & Ohio at Newark, Ohio, was announced in these columns last month, was born at Salem, N. Y., August 4, 1874.

He entered railroad service as a machinist apprentice on the Delaware & Hudson at Green Island, N. Y., in 1889, and at the end of four years was made a gang foreman in the same shop, serving in this capacity on various classes of work until 1896. He then left railway work and served as a machinist for the General Electric Company and other manufacturing companies for two years, when he again entered the Green Island shops of the Delaware & Hudson as foreman of the air brake department. In 1900 he became terminal foreman of the same road at Schenectady, N. Y., and after two years in this capacity was appointed general foreman at Plattsburgh, N. Y. In 1904 he was made division master mechanic of the Saratoga & Champlain divisions of the Delaware & Hudson, which position he occupied until 1912, when he was transferred to the Susquehanna division. He leaves this position to enter the service of the Baltimore & Ohio.

CAR DEPARTMENT

A. BERG has been appointed general foreman, car department of the New York Central at Wesleyville, Pa., succeeding O. Blodd, transferred.

O. BLODD, formerly general foreman of the car department of the New York Central at Wesleyville, Pa., has been transferred to Sandusky, Ohio, as general car foreman at that point, succeeding R. A. Fitz, transferred.

R. A. FITZ, formerly general car foreman of the New York Central at Sandusky, Ohio, has been transferred to Nottingham, Ohio, as general car foreman.

W. B. McNIECE, formerly car foreman of the Grand Trunk Pacific at Jasper, B. C., has been appointed car foreman at McBride, B. C.



N. M. Barker



W. Malthaner

T. SPENCE, formerly car foreman of the Canadian Pacific at Fort William, Ont., has been appointed general car foreman at Vancouver, B. C., succeeding W. C. Hodgson.

GEORGE THOMPSON, district master car builder of the New York Central at Englewood, Ill., has had his jurisdiction extended over the Illinois division.

SHOP AND ENGINE HOUSE

E. BLOOM has been appointed shop demonstrator and chief apprentice instructor, of the Chicago & North Western at Chicago, Ill., succeeding E. H. Morey.

GEORGE H. LAYCOCK has been appointed locomotive foreman of the Grand Trunk Pacific at Endako, B. C., succeeding George McNeil.

C. LUNDBURG has been appointed roundhouse foreman of the Chicago, Milwaukee & St. Paul at Chicago, succeeding A. Young.

JOHN McRAE, locomotive foreman of the Canadian Pacific at Revelstoke, B. C., has been appointed shop foreman at Kamloops, B. C., succeeding G. Dillard.

E. H. MOREY, shop demonstrator and chief apprentice instructor, has been appointed foreman of the new erecting and machine shop of the Chicago & North Western, at Chicago, Ill.

J. A. MITCHELL has been appointed locomotive foreman of the Grand Trunk Pacific at Biggar, Sask., succeeding A. S. Wright.

C. M. NEWMAN has been appointed superintendent of shops of the Baltimore & Ohio Southwestern at Washington, Ind.

COMMISSION APPOINTMENTS

Walter Alexander, who has just been appointed a member of the Railroad Commission of Wisconsin, has for the past 13 years held positions as assistant district master mechanic and district master mechanic at Minneapolis and Milwaukee of the Chicago, Milwaukee & St. Paul. The law creating the Railroad Commission requires that one member be familiar with transportation conditions and problems, and it was Governor Philipp's idea that a man who has had practical experience in railroad operation, as well as a technical training as a mechanical engineer, would be best suited for the position. Mr. Alexander was born in Glasgow, Scotland, and went to Milwaukee in 1873. After receiving a common school education he served an apprenticeship as a machinist and draftsman with the Chicago, Milwaukee & St. Paul, and was also employed as a fireman on that road. While so employed he prepared himself for college and entered the University of Wisconsin in 1893, graduating in the mechanical engineering course in 1897; and he received a second degree in engineering the following year. After three years' instructional work in engineering at the University of Wisconsin, one year at Armour Institute and one at the University of Missouri he returned to railroad service as assistant district master mechanic of the St. Paul at Minneapolis. Two years later he was transferred to Milwaukee to a similar position, and later was made district master mechanic, which position he has held up to the present.



Walter Alexander

SUPPLY TRADE NOTES

Jed O. Gould, general superintendent and works manager of the Gould Coupler Company, at Depew, N. Y., died Friday, February 19, at Buffalo, N. Y.

The Zug Iron & Steel Company, Pittsburgh, Pa., has been acquired by Jos. T. Ryerson & Son, Chicago. The plant is to be dismantled and a warehouse will be erected on the site.

George T. Merwin, formerly with the W. W. Butler Company, Ltd., Montreal, Que., has been appointed general sales manager of the Canadian Car & Foundry Company, Montreal, Que.

The Fairmont Machine Company, Fairmont, Minn., has changed its name to the Fairmont Gas Engine & Railway Motor Car Company, and has increased its authorized capital stock to \$1,000,000.

George Gibson Barret, formerly general manager of the Cleveland Drop Forge Company, and at one time connected with the American Locomotive Company, died at his home in Commack, L. I., on February 16.

James S. Llewellyn has been elected secretary, and Paul Llewellyn treasurer of the Chicago Malleable Castings Company. James S. Llewellyn will continue to hold the office of works manager at the West Pullman works.

John H. Trent, formerly railroad representative of the H. W. Johns-Manville Company, New York, at St. Louis, Mo., has been transferred to New Orleans, La., as branch manager, and has been succeeded at St. Louis by W. B. Mallette.

C. B. McElhany, assistant general manager of sales of the Cambria Steel Company, has been appointed general manager of sales, succeeding J. Leonard Replogle, who has resigned to enter the service of the American Vanadium Company.

William H. Kinney, formerly master mechanic of the New York, Ontario & Western at Carbondale, Pa., has entered the railroad sales department of the Dearborn Chemical Company, Chicago, and will have headquarters at the company's New York office.

C. H. Rhoadler, who has been connected with the St. Louis Surfacer & Paint Company, St. Louis, Mo., for four years, and with the Valentine Varnish Company for two years, was recently appointed western railway representative of the Kay & Ess Company, Dayton, Ohio.

C. F. Quincy, president of the Q & C Company, New York, has acquired the entire capital stock of the Railway Appliances Company, Chicago, formerly owned by Percival Manchester. The business of the Railway Appliances Company will hereafter be operated by, and in the name of the Q & C Company.

W. S. Ottinger, district sales manager of the Cambria Steel Company, has been appointed assistant general manager of sales, effective March 1, to succeed C. B. McElhany, promoted. Mr. Ottinger will be succeeded as district sales manager by F. J. Krouse. Albert S. Johnson will become assistant district sales manager, succeeding Mr. Krouse.

Due to the existence of a battery jar marketed under the name "Titan," and the fact that any battery using these jars might appear as a Titan battery, the Titan Storage Battery Company, Newark, N. J., has changed its name to the General Lead Batteries Company. No change whatever in ownership, officers or policy is involved. The change is made merely to avoid confusion.

Charles E. Poyer has been appointed assistant general sales manager of the Edison Storage Battery Company, Orange, N. J. Mr. Poyer has been with the Edison interests for about four years, having served first on the personal engineering

staff of Mr. Edison in the development of special applications of the alkaline battery, and later as assistant advertising manager. For the past two years he has been manager of the house lighting department.

James F. McElroy, president of the Consolidated Car Heating Company, Albany, N. Y., died at Laconia, N. H., on February 10. Mr. McElroy was prominent as an inventor and business man, and was identified with several of Albany's banking and mercantile institutions. He was born in Greenfield, Ohio, November 25, 1852, and was graduated from Dartmouth College in 1876. For four years following Mr. McElroy was the principal teacher of the Indianapolis Institution for the Blind, and then for seven years was superintendent of the Michigan Institution for the Blind. In 1887 he organized the McElroy Car Heating Company, operating its own patents. Two years later it was combined with the Sewall Car Heating Company.

J. Leonard Replogle, vice-president and general manager of sales of the Cambria Steel Company, since September, 1912, has resigned, effective March 1, to accept the position of vice-



J. L. Replogle

president and general manager of sales of the American Vanadium Company. Mr. Replogle has been in the service of the Cambria Steel Company for approximately 26 years. He was born in Bedford county, Pa., on May 6, 1876, and was educated in the public schools of Johnstown. He entered the employ of the Cambria Steel Company as an office boy when he was but 13 years of age and served successively as clerk, shipper, assistant superintendent of the axle department, superintendent of the forge, axle and bolt departments, assistant to the assistant general manager, superintendent of the order department, assistant general manager, assistant president and vice-president and general manager of sales. Mr. Replogle will have offices at New York and Pittsburgh.

H. Ward Leonard, president of the Ward Leonard Electric Company, Bronxville, N. Y., died suddenly of apoplexy, as he was about to attend a banquet of the American Institute of Electrical Engineers at the Hotel Astor, New York, on Thursday, February 18. Mr. Leonard was a prominent electrical engineer and inventor. He was born in Cincinnati on February 8, 1861. He graduated from the Massachusetts Institute of Technology, and when he was 23 years of age became associated with Thomas A. Edison as a member of Mr. Edison's staff of four engineers selected to introduce the Edison Central Station System. When he was 26 years of age he became general superintendent of the Western Electric Light Company at Chicago. The following year he formed the firm of Leonard & Izard, which made many important installations of central stations and electric railways. In 1889, when the firm was bought out by the Edison interests, Mr. Leonard became general manager of the combined Edison interests for the United States and Canada, with headquarters in New York. In 1891 he completed his inventions of the Ward Leonard system of motor control, and later introduced several other important inventions in the electrical field.

J. A. McFarland has been appointed southwestern district manager of the Bird-Archer Company, Chicago, with headquarters in the Frisco building, St. Louis, Mo. Mr. McFarland was born on



J. A. McFarland

October 23, 1880, at Mendota, Ill. After finishing his common school education he entered the University of Illinois, from which he graduated in 1903, having specialized in chemistry. He began railway work in May of the same year in the chemical department of the Atchison, Topeka & Santa Fe, at Topeka, Kan. On January 1, 1904, he became assistant in the testing department of the Chicago & North Western. In February, 1905, he became chief chemist of the Missouri Pacific, in which position he remained until May, 1909, when he

took charge of the St. Louis office of the Dearborn Chemical Company, Chicago, looking after the latter's railroad business in that territory. In July, 1911, he left that company to become chemist and engineer of tests of the Frisco System, and was later connected with the Standard Railway Equipment Company, New Kensington, Pa., until his recent appointment with the Bird-Archer Company, as noted above.

Lyndon F. Wilson, vice-president of the Railway List Company, Chicago, has resigned to become vice-president of the Bird-Archer Company, Chicago, effective April 1, 1915. Mr. Wilson was born at Rush



L. F. Wilson

Lake, Wis., November 4, 1883. He was educated at Ripon College, Lawrence University, and the University of Wisconsin. Before entering college, however, he was an operator in the office of his father on the Chicago, Milwaukee & St. Paul. Later, after having had considerable machine shop and power plant experience, he became an engineer in the Department of the Interior of the United States government, after having passed examinations in steam, electricity and heating and ventilating. After one year

in this service, he joined the engineering department of the Western Electric Company, and remained with the latter until the fall of 1908, when he became mechanical department editor of the Railway Review. In the spring of 1909 he became editor of the Railway Master Mechanic, and was subsequently given editorial charge of Railway Engineering, both being published by The Railway List Company, Chicago. He was promoted to the vice-presidency of this company in the summer of 1913. After April 1, Mr. Wilson will be located in the Chicago office of the Bird-Archer Company.

CATALOGS

TUMBLERS.—The Whiting Foundry Equipment Co., Harvey, Ill., has issued catalog No. 113 which is entirely given over to descriptions of the line of tumblers manufactured by this company for use in various classes of foundry work. The catalog, which is well illustrated, will be sent free upon request.

BRASS FOUNDRY EQUIPMENT.—Catalog No. 114 of the Whiting Foundry Equipment Co., Harvey, Ill., deals with the line of brass foundry equipment developed by this company. The line includes cranes, furnaces and tumblers as well as a line of tongs and shanks for handling crucibles. The catalog will be sent free upon request.

PAINT.—The first number of a publication to be known as *The Scientist* has been received from the Goheen Manufacturing Company, Canton, Ohio. It is intended to devote the space in this booklet to the advancement of the iron, steel and galvanized iron preservatives, as well as the water-proofing compound and damp-proofing paint of which the Goheen Manufacturing Company is the maker.

VALVES.—A 40-page catalog recently issued by the Homestead Valve Manufacturing Company, Homestead, Pa., deals with the different types of valves which this company manufactures. Illustrations and the principal dimensions of the different types are given and a cross-section showing the construction of the Homestead straightway valve is included on page 7, with detailed descriptive matter.

VENTILATION.—A pamphlet has been issued by the American Blower Company, Detroit, Mich., entitled *Ventilating the Fletcher Savings and Trust Company Building*. It contains a brief description of the Sirocco ventilating system as applied to an office building in Indianapolis, Ind. A number of drawings are included showing the layout of the system and a number of types of Sirocco multiblade fans are illustrated.

PAINTS.—The ninth edition of the *Review of Technical Paints*, by Frank P. Cheesman, has just been issued by Cheesman & Elliott, 100 William street, New York. This book contains 52 pages, is illustrated and is intended to give anyone interested in metal painting the benefit of the long experience of this firm. Various kinds of paints are considered in detail and information given as to the best paint to use for any particular class of work.

VALVE GEARS.—A booklet recently received from the Southern Locomotive Valve Gear Company, Knoxville, Tenn., contains some interesting data regarding the Southern valve gear. A number of indicator cards are included from locomotives fitted with this type of gear as well as data taken from the results of tests of locomotives to which this gear has been applied. Illustrations of the gear itself as well as locomotives fitted with it are included.

TAPS AND DIES.—The Wiley & Russell Manufacturing Company, Greenfield, Mass., has recently issued catalog No. 36, which deals with the screw cutting tools and machinery manufactured by this company. It is a book of pocket size containing 285 pages and besides illustrations and detailed information concerning the taps, dies, gages, etc., it contains, near the end, a number of tables of decimal equivalents, standards for wire gage, metric screw threads, etc.

SMALL TURBO-GENERATOR SETS.—The General Electric Company, Schenectady, N. Y., has issued an attractive bulletin, No. 42,010, describing in considerable detail the horizontal turbo-generator sets of small capacities. These machines are built in capacities ranging from 7 kw. to 300 kw. direct current, and 100, 200 and 300 kw. alternating current, and are used largely for supplying light and power in mills, machine shops, laundries, etc., as well as for train lighting.

SNOW FLANGERS.—A 16 page booklet has recently been received from the Railway Appliance Company, Old Colony building, Chicago, describing the improved type of Ray self-contained snow flanger. This device, which is applied directly to the locomotive, is designed to keep the rail and flangeway clear of light snowfalls. It is also used on wedge plows for clearing the flangeway. The booklet is well illustrated and contains a number of interesting photographs of snow-lighting scenes.

WATER SOFTENERS.—The Harrison Safety Boiler Works, Philadelphia, Pa., has recently issued a 20-page leaflet devoted to the Sorge-Cochrane Hot Process Water Softening System. The process, which is based upon the fact that chemical reactions are more rapid and complete in hot water than in cold water, is described in the leaflet which also contains a brief treatise on the chemistry of water softening. The text is well supplemented by a number of diagrammatic views showing the operation of the softener.

CENTRIFUGAL PUMPS.—This is the title of a 64-page bulletin, No. 19, just issued by the Terry Steam Turbine Company, Hartford, Conn., giving details and data on various turbo-pump applications. The principles of operation and construction of the centrifugal pump are explained, as are details of the steam turbine. Because of the wide latitude of speed possible with the turbine, the unit occupies a much smaller space than would be required for a pump performing the same duty but driven by a reciprocating engine.

MULTI-PORT VALVES.—Cochrane Multiport Valves is the subject of a booklet of 72 pages just issued by the Harrison Safety Boiler Works, Philadelphia, which describes the multiport valves introduced by that company for back pressure relief and vacuum service, flow service in connection with mixed flow turbines, and check valve service with bleeder or extraction turbines. The essential idea of the multiport valve is the use of a number of small discs instead of one large disc, in order to secure greater safety, quietness, lightness of moving parts and tightness.

ENGINEERING CALCULATIONS.—This is the title of a 23 page booklet issued by Felt & Tarrant Manufacturing Company, Chicago, which deals with the application of the comptometer to calculating work in the drafting room and the estimating department for a variety of calculations involving addition, multiplication, division and subtraction. It is well illustrated and contains numerous examples of the operations for which the machine is being used. The booklet will be of interest to those in charge of engineering offices and drafting rooms generally.

RAILWAY LINE MATERIAL.—The General Electric Company has recently issued bulletin No. 44,004, which forms an ordering catalog devoted to railway line material for direct suspension. This publication covers practically everything in line material for this method of suspension, except poles and wire. The parts are illustrated and each illustration is accompanied by the proper catalog numbers. The prices are not included. The bulletin contains also miscellaneous data relative to construction, overhead material per mile, general data on the use of solid copper wire and copper cable, dimensions of grooved trolley wire sections, etc.

PUMPS.—The National Transit Company, Department of Machinery, Oil City, Pa., has just issued bulletins Nos. 1, 2, 4, 101 and 301, all of which are contained in a neat binder and are devoted to its line of pumping machinery for general service recently added to the line of oil and gas pumping machinery which it has previously manufactured. In bulletin No. 1 are illustrated the pumps for different classes of service manufactured by this company including the duplex, crank and fly-wheel direct steam driven and geared pumps; a line of gas engines and a line of pipe fittings. The other bulletins are each devoted to a particular class of service.

Railway Age Gazette

MECHANICAL EDITION
 INCLUDING THE
AMERICAN ENGINEER

PUBLISHED ON THE FIRST THURSDAY OF EVERY MONTH BY THE
 SIMMONS-BOARDMAN PUBLISHING COMPANY,
 WOOLWORTH BUILDING, NEW YORK, N. Y.

CHICAGO: Transportation Bldg. CLEVELAND: Citizens' Bldg.
 LONDON: Queen Anne's Chambers, Westminster.

EDWARD A. SIMMONS, *President* L. B. SHERMAN, *Vice-President*
 HENRY LEE, *Secretary*

The address of the company is the address of the officers.

ROY V. WRIGHT, *Editor*

R. E. THAYER, *Associate Editor* A. C. LOUDON, *Associate Editor*
 C. B. PECK, *Associate Editor*

Subscriptions, including the eight daily editions of the *Railway Age Gazette* published in June in connection with the annual conventions of the Master Car Builders' and American Railway Master Mechanics' Associations, payable in advance and postage free:

United States, Canada and Mexico..... \$2.00 a year
 Foreign Countries (excepting daily editions).... 3.00 a year
 Single Copy 20 cents

Entered at the Post Office at New York, N. Y., as mail matter of the second class.

WE GUARANTEE, that of this issue 5,250 copies were printed; that of these 5,250 copies 4,568 were mailed to regular paid subscribers, 250 were provided for counter and news companies' sales, 231 were mailed to advertisers, exchanges and correspondents, and 201 were provided for samples and office use; that the total copies printed this year to date were 19,550, an average of 4,888 copies a month.

The RAILWAY AGE GAZETTE, MECHANICAL EDITION and all other Simmons-Boardman publications are members of the Audit Bureau of Circulations.

VOLUME 89

APRIL, 1915

NUMBER 4

CONTENTS

EDITORIALS:

Plate Spring Design	155
Advice to Apprentices	155
Reclaiming Scrap Material.....	155
Shop Craft Committee Meetings.....	156
The Economy of Good Workmanship.....	156
Handling Locomotives at Engine Houses.....	156
Steel Frame Passenger Equipment.....	157
New Books	157

GENERAL:

Heavy 2-10-2 Type Locomotive.....	158
Characteristics of Plate Springs.....	161
Reciprocating and Revolving Parts.....	163
An X-Ray Inspection of a Steel Casting.....	170

CAR DEPARTMENT:

The Defects of Modern Box Cars and Their Remedies.....	171
Box Car End Door.....	173
Grand Trunk Suburban Coaches.....	174
British All-Steel Kitchen Cars.....	178

SHOP PRACTICE:

Special Chucks for Air Pump Repairs.....	183
Piston Rod Gland and Oiler	183
Motor Drive for a Bradley Helve Hammer.....	184
An Inspiring Address to Apprentices.....	185
Turret Head for Planing Guides, Shoes and Wedges.....	187
Suggestions for a Properly Kept Roundhouse.....	187
Care of Lye Tanks.....	188
Log for Planing Eccentrics.....	188
Machine Steel for Small Tools.....	189
Results of the Locomotive Boiler Inspection Law.....	190
Portable Rivet Forge and Blow Torch.....	191
Post Cluster for Extension Cord Plugs.....	192
Using Old Boiler Tubes as Pipe.....	192
Fixing Standard Time for a Bonus System.....	192
Finishing Car and Engine Truck Brasses by Grinding.....	193
Turning Engine Bolts.....	193
Answers to Some Questions on Electric Arc Welding.....	195
Finishing Cylinder Cocks.....	195
Boring Front End Main Rod Brasses.....	196
Special Chucks for a Turret Lathe.....	196

NEW DEVICES:

Oxy-Acetylene Equipment	197
Small Single Acting Hydraulic Pump.....	197
Quintuple Punching and Shearing Machine.....	198
Exhaust Nozzle with Internal Projections.....	198
Heavy Duty Electric Reamer.....	199
Journal Box Packing Guard.....	200
Locomotive Wedge Bolt.....	200
Single Locomotive Water Joint.....	201

NEWS DEPARTMENT:

Notes	202
Meetings and Conventions.....	203
Personals.....	204
Supply Trade Notes	206
Catalogs	208

Plate Spring Design

The design of plate springs is a subject in which many railway mechanical men have a deep interest. It is one which has been almost entirely based upon theory with but little exact data of a practicable nature by which to check or modify the formulas generally used. On another page appears the first of a series of articles on Plate Springs by G. S. Chiles. These articles are based on the results of extensive tests and contain much valuable data relative to the characteristics of various types of plate springs. The concluding article will be largely devoted to design and will contain recommendations for modifications in the present practice.

Advice to Apprentices

A few weeks ago George M. Basford, who is regarded as the father of modern railway shop apprenticeship, made an address before a meeting of the Chicago & North Western apprentices at Chicago. He took as his subject "Heroes," and clearly outlined the underlying principles which govern the development and advancement of ambitious young men who desire to make good in the railway mechanical department organization. The principles outlined in this article, which is given elsewhere in this issue, are, of course, equally true for young men who desire to advance in any other occupation or profession. The unfortunate part of the whole business is that such a comparatively small number of the apprentices can be forced to stop and think and take advantage of advice of this sort. We hope that not only the young men who read the article will take it to heart, but that the older men who have charge of apprentices will bring it to the attention of the young men and try to get them to realize its great importance to them if they intend to make a success of their work. We shall be glad also to hear from any of the apprentices as to their experiences in regard to apprenticeship and as to how, in their opinion, the instruction which they are receiving and the schedules which they are following could be better arranged to meet the needs of railway shop apprentices of today.

Reclaiming Scrap Material

It is difficult to compare the performances of two different roads in reclaiming scrap, as the conditions are usually very different. The problem in most instances is a local one, and the fact that one road shows a saving in reclaiming certain classes of material does not necessarily mean that another road can obtain the same results. It does indicate possibilities, however, and a study of the conditions under which one road operates its reclaiming plant may show the investigators how their plant might be improved.

The selection of the foreman for a reclaiming plant is of prime importance. The peculiar characteristics of the work require a man who is energetic and ingenious; he must be capable of exercising good judgment in the selection of the material to be reclaimed and of developing methods to make it serviceable at the smallest possible cost. Such a man, with an efficient and well-trained organization, will find no difficulty in showing that money can be saved in scrap reclamation. In addition, he must be supported by competent accountants, men capable of determining very closely the cost of reclaiming the various materials in order that he may know just where he stands. The desirability for this close supervision would indicate that better results can be obtained by having the reclamation work handled by a separate organization located preferably at some important shop point near the scrap market.

The question has been raised as to whether this work should come under the stores or mechanical departments. Both are directly interested. It is the duty of the stores department to keep the purchase of material at the lowest point practicable and still carry enough material to meet the demands of the road. The mechanical department is interested in that it receives the

beneit of the money saved by reclamation. It, therefore, behooves both departments to work together, regardless of which has direct control of the plant. The work itself is, of course, mechanical, and the mechanical men are more capable of determining what can be done in the matter of reclamation.

The question of investment in equipment for a reclaiming plant is also important. There may be just as much money lost in the operation of inefficient machines in the scrap shed as in the best shop on the system, and the use of inefficient machines may mean the difference between a profit and a loss in doing some of the work.

Shop Craft Committee Meetings

The mental attitude of the workman toward his employer is an important item in shop administration. In the railway shop particularly there is often lacking that personal feeling that many times naturally exists between the owner of a small industrial shop and his men. At all of the shops of the Illinois Central an effort has been made to bring the men into closer touch with the organization by the appointment of a shop craft committee. This committee is composed of representatives from each department or craft and meets monthly in the office of the shop superintendent. At these meetings the general welfare of the men, the shop conditions, and safety are discussed with a view to determining at first hand just what complaints the men have, how their working conditions can be improved and to instil into their minds, through their representatives, the necessity of doing their work with the idea of safety to themselves and their fellow workmen. It is explained that the shop is operated on a monthly appropriation basis, and that what they save in material will work towards an increase in what may be expended for labor, which may mean longer hours, with the accompanying increase in pay, or the employment of more help. The men appreciate the fact that the company is seeking to improve their conditions, and in many cases they recommend improvements that are of direct economic advantage to the company. This practice has been in effect for some time and is regarded as an important feature in the shop administration. That the purpose of the committee may be more thoroughly understood by the men, each member is appointed for only two consecutive months, the members being appointed by the men themselves.

The Economy of Good Workmanship

The general foreman of a large eastern shop after showing a visitor a number of examples which indicated clearly the high quality of the workmanship, said, "It doesn't cost any more to do work that way—and it doesn't come back." The conditions obtaining in railway shop work do not tend toward encouraging the highest quality of workmanship. Locomotives must be kept in service the greatest possible proportion of the time and transportation officers are wont to make frequent inquiry as to when certain engines will be ready, so that the shop staff is under a steady pressure in turning out work. There is, therefore, an almost constant tendency, or perhaps it might be more properly termed temptation, to leave something undone or to shirk the method of its doing. Whether or not such practice is cheaper in first cost than if time and care were taken to produce a first class job, there can be no doubt that the after effects are expensive, for such work does "come back" in many ways.

A brief consideration of one or two examples will show very plainly how expensive poor workmanship really is. A locomotive that returns to the engine house from the yard because a cylinder cock that was booked off as O. K. refuses to stay closed, will cost much more in terminal delay to the engine and train crews alone than the expense of doing the job properly and trying the cylinder cocks thoroughly at the shop to insure their working satisfactorily. The widespread effects of

any engine failure are of such a nature that the direct cost cannot be counted, but it is safe to say that it would much more than pay for any work that would have prevented the failure. Under the bombardment of questions and requests for power that a foreman receives from the transportation officers he would be superhuman if he did not permit *some* work to go out which could not be classed as good; but an hour or so added to the time an engine is in the shop is many times better than an engine failure. The trainmaster who complains of the length of time a locomotive is held under repairs would complain much more strenuously if the same engine were hurried out and as a result gave up a train on the road. In either case the shop foreman is the victim, but it is a great deal easier to explain a shop delay caused by an effort to prevent an engine failure than it is to explain neglected work which resulted in a failure. The wise foreman will see to it that his work "doesn't come back."

Handling Locomotives at Engine Houses

The function of an engine house organization is to take the locomotives as they come from the trains, make the necessary repairs and prepare them for service as quickly as possible. In the movement of a locomotive through the routine of a mechanical terminal there are two or three points to which we believe greater attention should be given than is the general practice. With regularly assigned engines, which have to lie at a terminal a certain length of time as a minimum, the quicker the work which is done outside the engine house is completed, the more time there will be available for the more important work which is done inside. In the case of pooled engines all of the work must be done as quickly as possible; so that in general it can be stated that despatch should be used in getting locomotives by the coaling plant and over the ashpit. The work of coaling can be done with but slight delay if the equipment is modern; but at an engine house with out-of-date facilities, co-operation with the shopmen is necessary if serious delays are to be avoided. For instance, if an engine is fifth or sixth in the line at the coaling plant and the boiler washing gang is doing nothing pending its arrival in the engine house, the foreman, if he is a man who keeps in close touch with his organization, will order that engine to the ashpit and thence to the house without coal, leaving the work of coaling to be taken care of on the way out, and if necessary having the firing up done enough earlier to provide for this.

At the ashpit, while speed is desirable, care must be taken not to make improper use of the blower and the injectors, and at the same time to carefully clean the fire, or dump it if that is necessary, so that the grates will be left clean. Here again, by keeping in touch with the shopmen, considerable time can be saved. An engine requiring boiler work can be blown down while on the ashpit to a pressure just sufficient to work the engine over the turntable, and a saving both in time and in water can be effected by not working the injectors.

Stress is laid on the quick handling of the outside work, first because a machinist or a boilermaker cannot tell until he has had a chance to carefully examine the work entered in the work book, whether it is likely to result in a long job or a short one. There may be some hidden trouble which was not apparent to the engineman or inspector who made the work report, and if such is the case all the time which is available may be necessary to get the engine ready for service again. Second, the repairing of locomotives is the most important part of the terminal work and the more time given to it, the better the work is likely to be done. An engine house staff should, therefore, be provided with an ample number of capable hostlers and ashpit men to reduce to a minimum the time that locomotives stand outside the shop after their arrival. This is particularly true in the winter months, when it is an easy matter for them to freeze up or develop leaky tubes, causing added trouble and expense, and probably delay.

Steel Frame Passenger Equipment

We have grown so accustomed in the United States to steel cars in passenger trains that we now take them as a matter of course. The public demand for steel cars was met—or at least a start was made toward meeting it—almost before it was made and there are now few roads of importance in this country that do not operate steel passenger train cars in considerable numbers. Some of the mistakes made in the designing of the first cars have been discovered, and are being remedied in later designs; but there is still room for improvement in some of the designs of steel cars now in service, particularly as regards noise and heating. In Canada, where the winter temperatures are much more severe than those encountered in general in the United States, the Canadian Pacific has placed in service a number of steel cars which it is understood are proving satisfactory from the standpoint of temperature, both in summer and winter. These cars were described in the *Railway Age Gazette, Mechanical Edition* for May, 1914, page 237.

In deciding on the use of steel cars consideration must be given to the facilities available for repairs, and the officers of a road on which it will be necessary to go to the expense of building and equipping a shop for repairs to steel passenger equipment if that type of car is adopted, are likely to move slowly, particularly under present conditions. Confronted with the necessity for new equipment in the Montreal suburban service, the officers of the Grand Trunk developed a car design of special interest at this time, when the all-steel car has become so common. This car is described elsewhere in this issue. In order to produce a car with ample strength, which could be kept comfortable in all temperatures and be repaired with the facilities now available on the road, a design was adopted having a steel frame and ends, and reinforced and finished with wood. The danger from fire was carefully considered; but even an all-steel car cannot be made entirely fireproof because of the upholstery, and with steam heat and electric light the danger of fire should be small except in the case of telescoping over the locomotive firebox, a danger which should be slight in this case.

First consideration would lead to the belief that such a car would be unusually heavy, but although the length of the car body is 70 ft., the weight is but 137,000 lb., which with a seating capacity of 96 gives a dead weight per passenger of 1,427 lb. This figure is below the average for all-steel cars, this being about 1,500 lb., while the minimum is in the neighborhood of 1,200 lb. The use of heavier locomotives makes it possible to haul seven of the new cars in a train, giving a total seating capacity of 672 as against 250 in the previous five-car trains, the dead weight per passenger in the latter being 1,500 lb.

NEW BOOKS

The Electric Furnace in Metallurgical Work. By Dorsey A. Lyon, Robert M. Keerey and Joseph F. Cullen. 190 pages, 6 in. by 9 in. Bound in paper. Illustrated. Published by the Department of the Interior, Bureau of Mines, Washington, D. C.

This book is bulletin No. 77, published by the Bureau of Mines and is divided into three parts. Part I treats of the design, construction and operation of electric furnaces. Part II of the smelting of metals in the electric furnace and Part III of the manufacture of ferro-alloys in the electric furnace. The bulletin mittee and is a revision of the questions and answers previously issued by this association.

Steam Charts. By F. O. Ellenwood, assistant professor of Heat Power Engineering, Cornell University. 91 pages, 7 in. by 9½ in. Bound in cloth. Published by John Wiley & Sons, Inc., 432 Fourth avenue, New York.

This book was prepared for the use of engineers, teachers and students who are called upon to solve problems involving the

properties of steam, both wet and superheated. For the steam tables usually employed in such work charts have been substituted; with total heat and specific volume as the co-ordinates sets of constant temperature, constant pressure, constant quality, constant superheat and constant entropy curves have been plotted. The graduations have been arranged on a decimal basis, thus facilitating interpolation between the values plotted on the chart. The use of a single chart to include the total range of pressures and temperatures to be met in engineering practice would be extremely awkward. Such a chart in folder form when in use would take up the large part of the top of a desk. Aside from this disadvantage it would soon become worn at the folds and its serviceability greatly impaired. The author has therefore chosen to divide the chart into a number of sections, each section being subdivided horizontally into an upper and lower part, which are placed on facing pages. These pages are preceded by an index chart showing the various sections in their proper relative position and showing the range of values for the variables on each section, by referring to which the proper section to use in any specific case is readily determined. About half of the volume is devoted to problems, the solutions of which are worked out by the use of the charts. The introduction contains a brief statement of fundamental principles, these being included for the benefit of those wishing a brief review of thermo-dynamics, and an explanation of the use of the charts. In addition to the steam charts the book contains tables of barometric corrections and theoretical steam velocities. The graphic presentation of data possesses several advantages over the use of tables and the principal objection to the use of charts—the difficulty of securing sufficient range in practicable space limitations—has been admirably met by the author in this volume.

Examination Questions and Answers. Compiled by a committee of the Traveling Engineers' Association. 205 pages, 4¼ in. by 6½ in. Bound in cloth. Published by the Traveling Engineers' Association, W. O. Thompson, East Buffalo, N. Y., secretary. Price \$1 per copy, or 65 cents per copy in lots of five or more.

These questions and answers are for firemen seeking promotion, and for new men to be employed. They were compiled by a committee of the Traveling Engineers' Association, of which W. H. Corbett, division master mechanic of the Michigan Central, was chairman. The book is divided into three series, the first series containing examination questions and answers on which the firemen will be examined at the end of the first year. The second series is for the second year examination, and the third series is questions and answers which the firemen will be expected to know before being promoted to the position of engineer. The first series deals with the fireman's duties and includes considerable information on the combustion of fuel and the proper method of firing. A few questions are also given concerning the air brake.

The second series of questions also contains instructions as to the proper method of firing and deals with problems in boiler maintenance and construction with which the fireman should be familiar. It also contains information regarding injectors and lubricators. Further questions are also asked concerning air brakes, and the subject of oil burning locomotives is gone into quite thoroughly. The third series covers the duties of an engineer and gives considerable information regarding the maintenance of the machinery of a locomotive while on the road. This series also includes information regarding break-downs. Compound locomotives are considered in some considerable detail, as are the Walschaert and Baker-Pilliod valve gears, lubricators, and electric head lights. The different types of air pumps and air brake apparatus on locomotives are also considered in considerable detail, 151 questions being asked on this subject. This book was most carefully compiled by the committee and is a revision of the questions and answers previously issued by this association.

HEAVY 2-10-2 TYPE LOCOMOTIVE

Erie Engine Has 63 in. Drivers, 31 in. by 32 in.
Cylinders and Total Engine Weight of 407,700 lb.

A large locomotive of the 2-10-2 type has recently been placed in service by the Erie Railroad. It was built by the Baldwin Locomotive Works and is slightly heavier than the locomotives of this type built last year by the same company for the Baltimore & Ohio.* The new locomotive has 63-in.

more & Ohio locomotives. In the following table is a comparison of the leading dimensions of these locomotives:

Road	B. & O.	Erie
Tractive effort.....	84,500 lb.	83,000 lb.
Weight on drivers.....	536,800 lb.	527,250 lb.
Weight, total engine.....	406,000 lb.	407,700 lb.

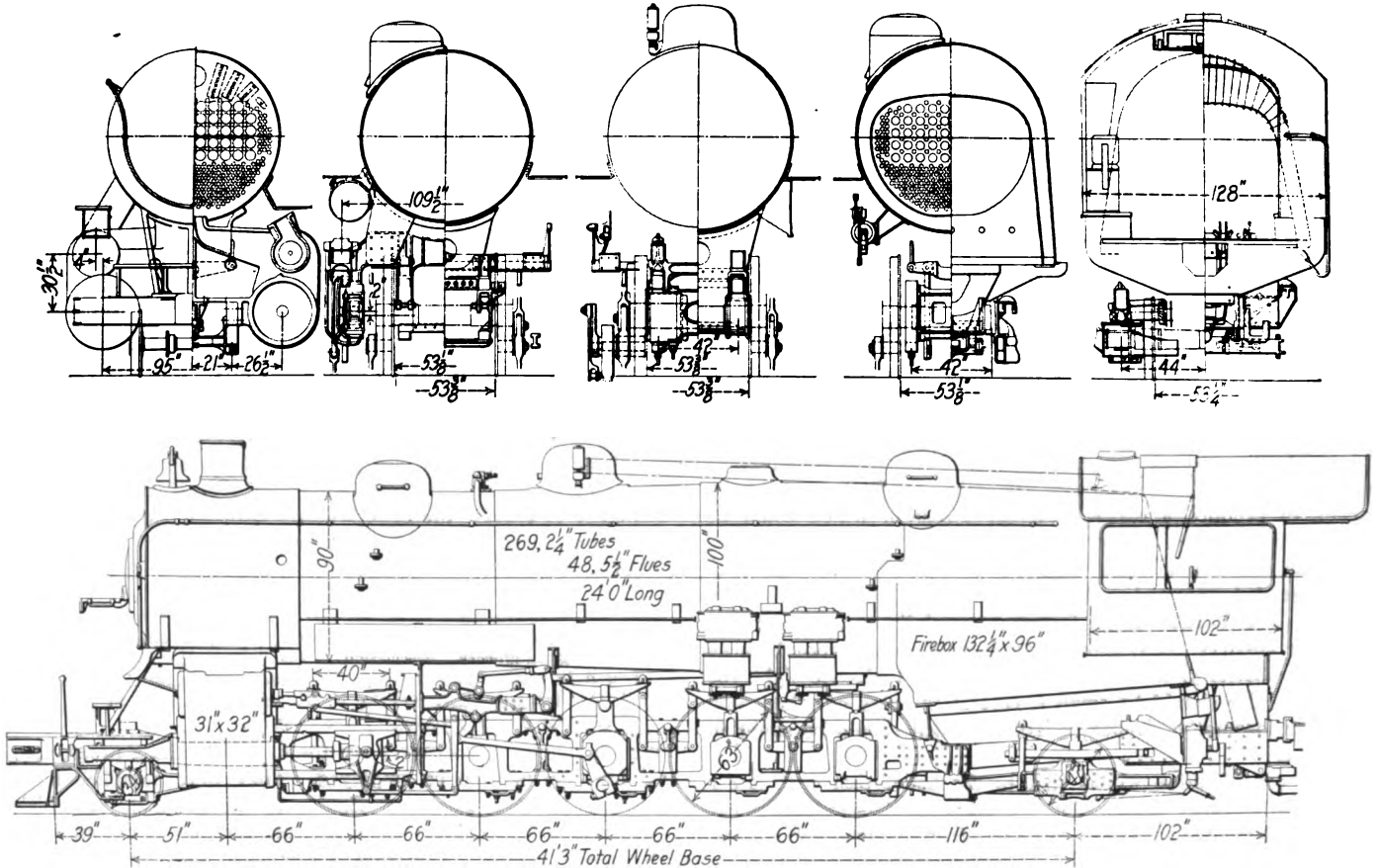

General Arrangement of the Erie Railroad 2-10-2 Type Locomotive

drivers, the largest which have yet been placed on an engine of the 2-10-2 type, and by using 31-in. cylinders the tractive effort has been maintained very nearly to that of the Balti-

Drivers, diameter	58 in.	63 in.
Cylinders, diam. and stroke.....	30 in. by 32 in.	31 in. by 32 in.
Steam pressure	200 lb.	200 lb.
Evaporating heating surface.....	5,573 sq. ft.	5,801 sq. ft.
Superheater heating surface.....	1,329 sq. ft.	1,377 sq. ft.
Grate area	88 sq. ft.	88.1 sq. ft.

*For a description of the Baltimore & Ohio 2-10-2 Type, see *Railway Age Gazette, Mechanical Edition*, September, 1914, page 456.

The boiler of the Erie locomotive is similar in construction

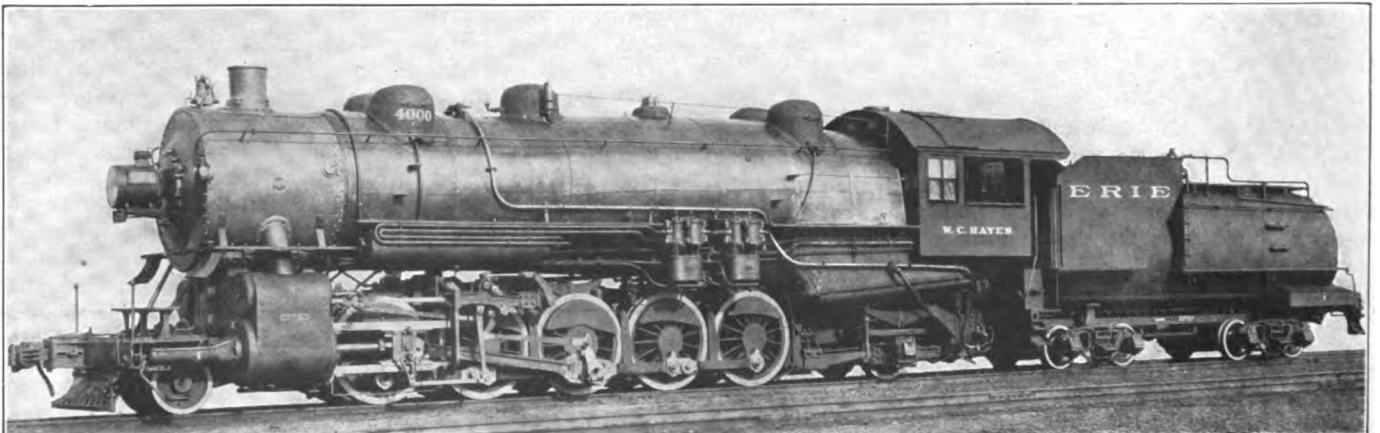

Erie Locomotive of the 2-10-2 Type Which Develops 83,000 lb. Tractive Effort

to that of the Baltimore & Ohio locomotive illustrated in the description above referred to. The difference in the heating surface is due almost entirely to an increase in the length of tubes, which are 24 ft. long as compared with a length of 23 ft. in the boilers of the Baltimore & Ohio locomotives. The tubes are welded into the back tube sheet. The new boiler has a conical ring in the middle of the barrel which increases the shell diameter from 90 in. to 100 in. The main dome is

special attention has been given to the exhaust passages, which are unusually direct and of liberal section area. Steam distribution is controlled by 16-in. piston valves driven by the Baker gear and set with a lead of 3/16 in. The locomotive is equipped with the Ragounet power reverse gear.

The reciprocating parts are comparatively light for an engine of this size. Forged and rolled steel pistons of Z-section are used. The guides are of the alligator type with a vertical

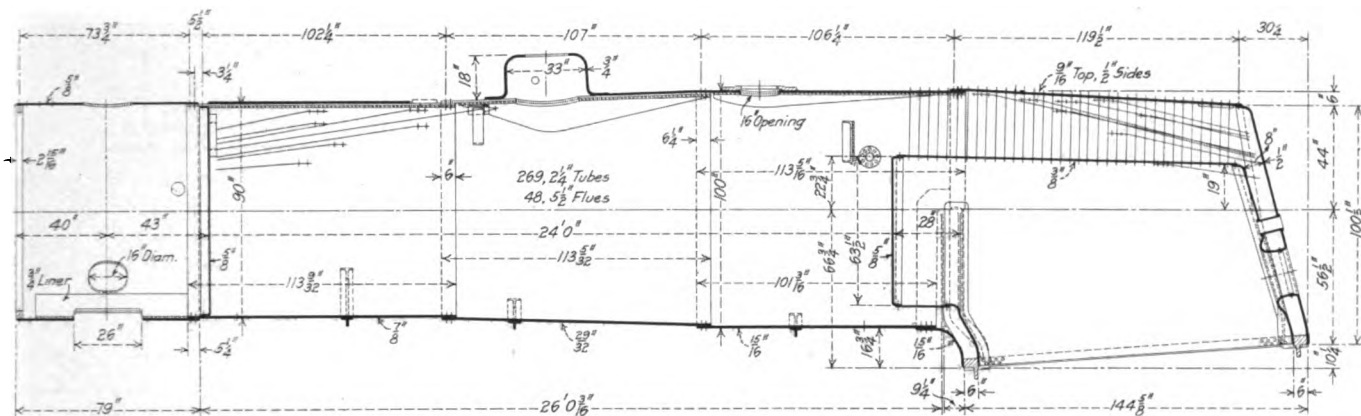

Sectional Elevation of the Boiler of the Erie 2-10-2 Type Locomotive

of pressed steel in one piece and is mounted on the connection ring, while the auxiliary dome is forward of the firebox on the third ring and is placed over a 16-in. opening in the shell. The boiler contains a combustion chamber 28 in. long. There is a full installation of flexible staybolts in the water legs, and four rows of flexible bolts support the front end of the combustion chamber crown. The equipment includes a Schmidt superheater, Security brick arch, Street stoker,

distance of 20 in. between the bars. The crossheads have steel bodies with bronze gibs 32 in. in length and are very simple in design. They weigh 785 lb. apiece, and although large in itself, this weight may be considered low for the size required. The front and back main rod stubs are of the Markel type with removable brasses. As shown in one of the drawings, the cast steel filling blocks in the main stub are cored out to remove as much weight as possible.

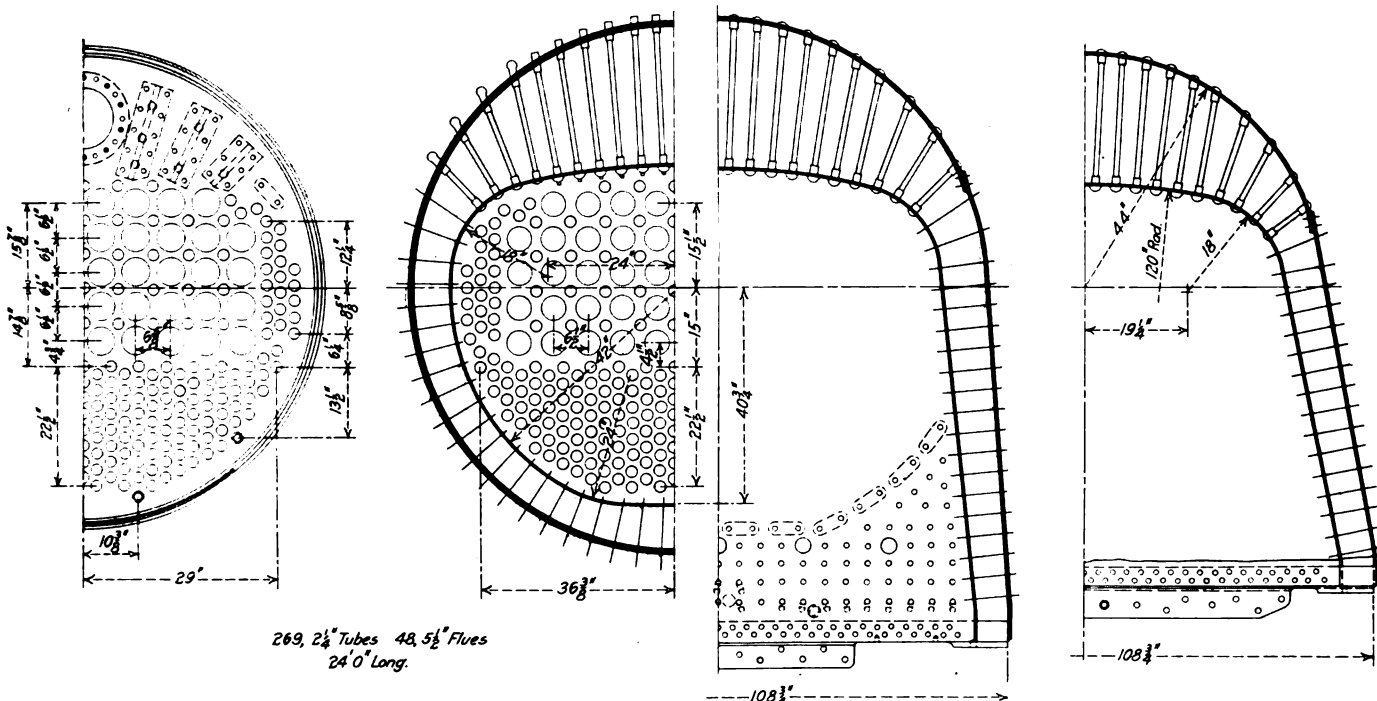

Cross-sectional Elevations of the Boiler

Talmage ash-pan and blowoff system, Franklin grate shaker and fire-door and Chambers throttle valve.

The cylinder castings are simple and massive in design, and are secured to the frames by 12 horizontal 1 1/2-in. bolts each. Both the cylinders and steam chests are fitted with bushings of Hunt-Spiller gun iron and the same material is used for piston and valve packing rings. In designing the cylinders

Owing to the comparatively large diameter of the wheels and the relatively light reciprocating weights it has been possible to balance the locomotive very satisfactorily. It was unnecessary to resort to the use of auxiliary counterweights on the main axle, and lead has been used in the counterweights of the main wheels only.

The frames are Vanadium steel castings with rear sections

of forged iron. The main frames are 6 in. in width and are spaced 42 in. between centers. The single front rails are cast integral with the main sections and in front of the cylinders they are bolted to a combined deck plate and bumper casting furnished by the Commonwealth Steel Company, in which is housed the Miner draft gear. This is a large and elaborate casting and it has been cored out wherever possible, to save weight. Poling pockets are cast in the bumper.

The driving wheels have a total lateral play in the boxes of 1/4 in., and the first and fifth pairs have 1/4 in. more play between the flanges and rails than the second and fourth pairs. The main wheels have plain tires, and in spite of the long rigid wheelbase the locomotive will traverse 16-deg. curves. The engine has the Woodard leading truck, the Cole trailing truck and Cole long main driving boxes.

Wherever practicable, details have been made interchangeable with corresponding parts of the Erie's latest Mikado type locomotives. Such parts include the tender trucks complete, the pilot, frame-crossies, brake shoes and heads, many brass fittings and the following parts, except for the main wheels: driving boxes, axles, tires and shoes and wedges. Flange oilers are applied to the leading wheels and a speed recorder is operated from the rear truck.

The tender is of the Vanderbilt type, having a water capacity of 10,000 gal., and a coal capacity of 16 tons. The frame is composed of 6 in. by 4 in. angles, with front and back bumper beams of cast steel. The trucks have cast steel side frames and solid rolled steel wheels manufactured by the Standard Steel Works Company.

The 2-10-2 type, although not yet generally in use, has met with marked success in heavy freight service and the large boiler capacity, together with the comparatively large driving

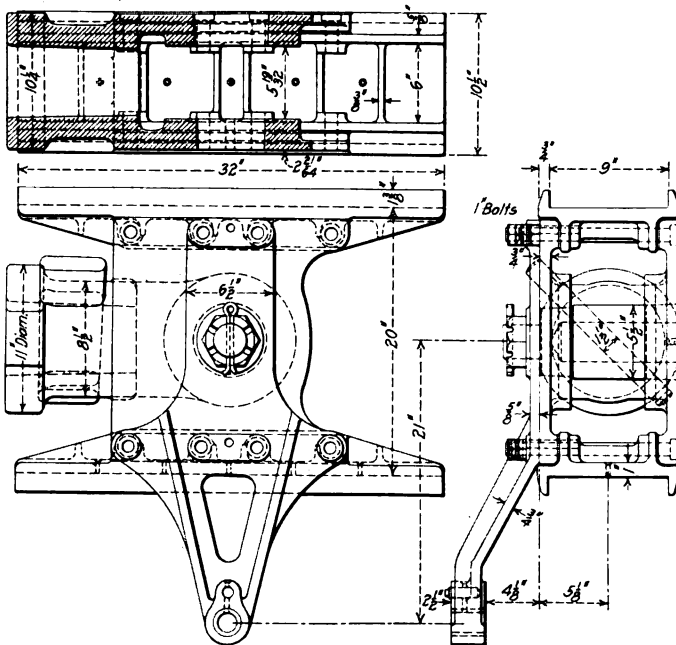

Crosshead of the Erie 2-10-2 Type Locomotive

wheel diameter of the Erie locomotive, indicates the possibility of further development in this type toward sustained capacity at higher speeds.

The following are the principal dimensions and data:

General Data

Gage	4 ft. 8 1/2 in.
Service	Freight
Fuel	Soft coal
Tractive effort	83,000 lb.
Weight in working order	407,700 lb.
Weight on drivers	327,250 lb.
Weight on leading truck	24,450 lb.
Weight on trailing truck	56,000 lb.
Weight of engine and tender in working order	586,300 lb.

Wheel base, driving	22 ft.
Wheel base, total	41 ft. 3 in.
Wheel base, engine and tender	77 ft. 4 1/2 in.

Ratios

Weight on drivers ÷ tractive effort	3.94
Total weight ÷ tractive effort	6.18
Tractive effort × diam. drivers ÷ equivalent heating surface*	664.72
Equivalent heating surface* ÷ grate area	89.29
Firebox heating surface ÷ equivalent heating surface* per cent.	3.28
Weight on drivers ÷ equivalent heating surface*	41.60
Total weight ÷ equivalent heating surface*	51.83

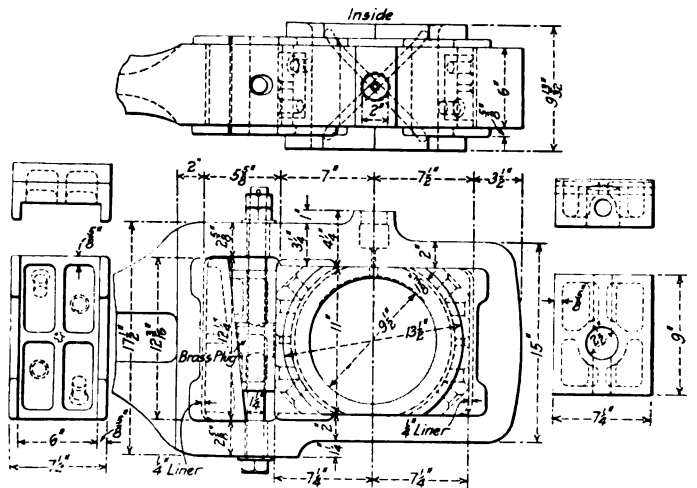

Markel Main Rod Stub with Cored Filler Blocks

Volume both cylinders	27.95 cu. ft.
Equivalent heating surface* ÷ vol. cylinders	281.45
Grate area ÷ vol. cylinders	3.15

Cylinders

Kind	Simple
Diameter and stroke	31 in. by 32 in.

Valves

Kind	Piston
Diameter	16 in.

Wheels

Driving, diameter over tires	63 in.
Driving, thickness of tires	3 1/2 in.
Driving journals, main, diameter and length	13 in. by 22 in.
Driving journals, others, diameter and length	11 in. by 13 in.
Engine truck wheels, diameter	34 in.
Engine truck, journals	6 in. by 12 in.
Trailing truck wheels, diameter	42 in.
Trailing truck, journals	9 in. by 14 in.

Boiler

Style	Conical
Working pressure	200 lb. per sq. in.
Outside diameter of first ring	90 in.
Firebox, length and width	132 1/4 in. by 96 in.
Firebox plates, thickness	Sides, back and crown, 3/8 in.; tube, 5/8 in.
Firebox, water space	16 in.
Tubes, number and outside diameter	269—2 1/2 in.
Flues, number and outside diameter	48—5 1/2 in.
Tubes and flues, length	24 ft.
Heating surface, tubes	5,443 sq. ft.
Heating surface, arch tubes	37 sq. ft.
Heating surface, firebox	258 sq. ft.
Heating surface, total	5,801 sq. ft.
Superheater heating surface	1,377 sq. ft.
Equivalent heating surface*	7,866.5 sq. ft.
Grate area	88.1 sq. ft.

Tender

Weight	178,600 lb.
Wheels, diameter	33 in.
Journals, diameter and length	6 in. by 11 in.
Water capacity	10,000 gal.
Coal capacity	16 tons

*Equivalent heating surface = total evaporative heating surface + 1.5 times the superheating surface.

TRAFFIC THROUGH THE PANAMA CANAL.—More than a million tons of freight have been carried through the Panama canal during the first three months of its operation. Thus far, the west bound traffic has been in excess of eastbound traffic, westbound being 621,080 tons as compared with 457,991 tons eastbound. More than 95 per cent of this traffic was on the four great routes which developed soon after the canal was opened; the United States coastwise trade, the traffic between the Pacific coast of the United States and Europe, the trade of the west coast of South America with the Atlantic seaboard of the United States and with Europe and traffic between the Atlantic coast of the United States and the Far East.—*American Machinist*.

CHARACTERISTICS OF PLATE SPRINGS

Part I: The Effect of Friction; Relation of Service to Test Deflections; Detecting Permanent Set

BY GEORGE S. CHILES

While much has been written in recent years on plate springs, the treatment of the subject has been largely of a theoretical nature, consisting in the derivation, analysis and comparison of various formulas used in designing springs. The object of Part I of this article will be to describe the characteristics of plate springs as observed in a series of experiments, both in the laboratory and in service. The effect of friction under various conditions is brought out in its relation to methods of testing and to service performance.

Part II will deal with the effect of the characteristics of materials and of methods of manufacture upon the action of plate springs. As far as possible the results of the tests will be used to explain why actual and theoretical performance are often at vari-

ured as the load is applied, or as it is released, and what load is to be used in testing for permanent set are questions the settlement of which will seriously affect the results obtained.

In Fig. 1 are plotted the deflections obtained by the application of a compression load of 23,100 lb. to a number of locomotive driving springs. The springs are all of the same general dimensions, but are divided into three groups differing in chemical composition and the method of assembling. The springs in group *A* were built up of carbon spring steel, and were removed from several heavy Pacific type passenger locomotives after having been in service several months. Those in group *B* were new, with a vanadium content; and in assembling, the plates had been painted with a mixture of oil and graphite. Those in group *C* were old carbon steel springs which had been reset, retempered and the plates painted with a mixture of oil and graphite.

After an initial load of 29,000 lb., equivalent to a 25 per cent overload, had been applied and removed three times the camber was measured. The static load of 23,100 lb. was then applied and the camber of the spring again measured. The deflections recorded are the differences between the free camber and that with the static load applied. They varied from 1.4 in. to 1.9 in. for group *A*, the average being 1.63 in. The deflections for group *B* are considerably greater and much more uniform than those for group *A*, ranging from 2.2 in. to 2.4 in. and averaging

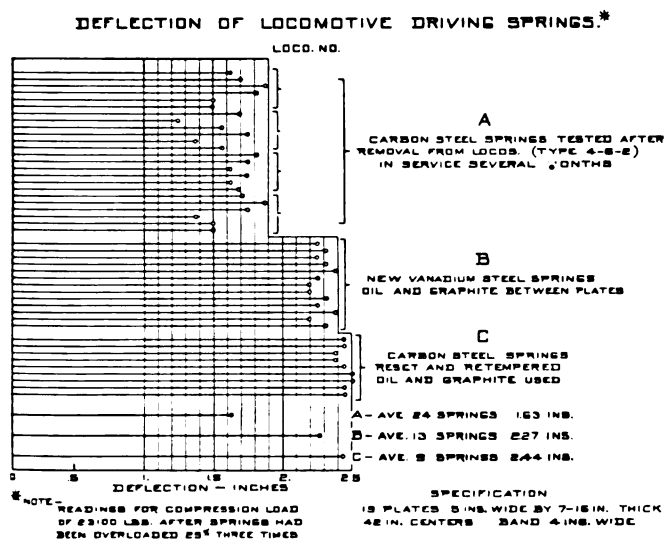

Fig. 1

ance. The bearing of the results upon the subject of design will be considered with suggestions for an improved formula for deflection.

Before proceeding further the writer wishes to acknowledge his indebtedness to those whose willing co-operation has aided him in securing the data upon which the article is based, especially to R. G. Kelley for his able assistance.

METHODS OF TESTING

In order to secure satisfactory results in testing plate springs it is necessary before recording data to apply and remove an initial load several times, this load varying according to the condition of the springs. For repaired springs or those tested after removal from service the load used amounts to about 25 per cent over the static load for which the spring is designed while for new springs it is usually taken at about 50 per cent over the static load. The limbering up of the spring in this manner eliminates slight irregularities which may be due to internal friction, initial stress resulting from the fitting and banding of the plates and the attendant temperature changes, or the taking of a slight permanent set at or below what is ordinarily considered as the elastic limit of the material. Unless this practice is followed it is impossible to verify deflection readings by duplicating tests. Springs rarely, if ever, return to the original free height after the removal of an initial load even as small as 50 per cent of the static or rated loading.

In deflection tests on steel plate springs the methods to be used require careful attention. Whether the deflection is meas-

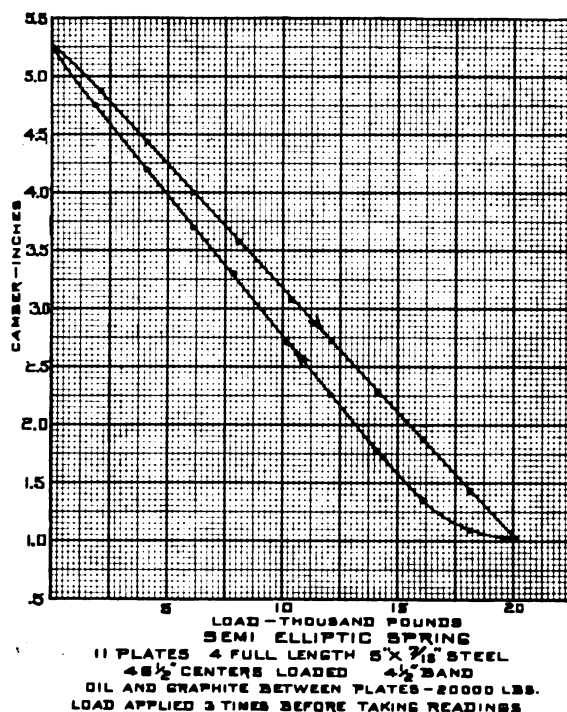

Fig. 2

about 2.27 in. The deflections for group *C* are still greater and more uniform, varying from 2.4 in. to 2.5 in., the average being 2.44 in. It will be noted that the results obtained by this method for new springs with oil and graphite between the plates are fairly uniform while the variations in deflection of old springs are so great as to make the results practically worthless as a means of checking individual springs with formulas or specifications. The causes for these variations will be discussed more

fully later on and attention is called to them at this point only to show the unreliability of data obtained in this manner.

The results of a better method of testing, and one which is quite generally used are shown in Fig. 2. The abscissas represent the load in thousands of pounds and the ordinates the camber of the spring in inches. After being limbered up, the free height, or the camber of the spring, was measured and found to be 5 1/4 in. The next step was to apply a load of about 2,000 lb., and again record the camber which in this instance was 4.88 in. Without removing this load an additional 2,000 lb. was added, bringing the load up to about 4,000 lb. This reduced the camber to about 4.45 in. In like manner successive points on the curve were determined, the camber gradually decreasing to one inch at a load of 20,000 lb. The operation was now reversed; that is, the load was reduced by about 2,000 lb., bringing it down to 18,000 lb. It should be noted that the camber instead of returning to 1.45 in., is now only 1.10 in. In other words, with the removal of the final increment of 2,000 lb., the spring did not return to the position it had occupied previous to the addition of this increment. Likewise, each successive point on the release load curve will be found to be of smaller value than its correspond-

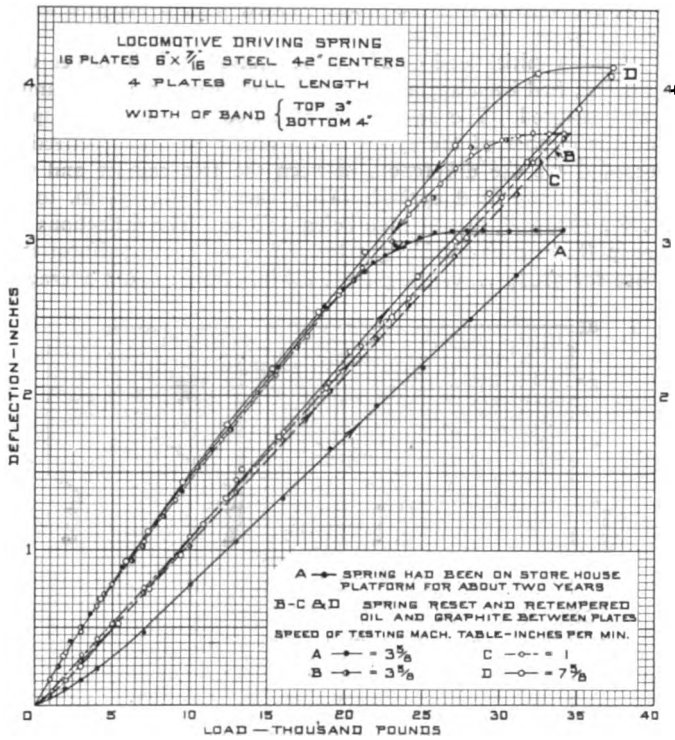

Fig. 3

ing point on the applied load curve, though the difference between the two curves diminishes as they approach the point of zero load, which is the same for both curves.

The reason for this difference in the camber of the spring for the same load is due mainly to the friction existing between the individual plates composing the spring. To some extent, the time effect must also be taken into consideration. Upon the application of a load, an elastic elongation or deformation immediately takes place, even though the resulting stress is much below the primitive elastic limit, but the permanent or plastic deformation, ordinarily considered a negligible quantity, does not occur until after the elapse of a period of time. As this permanent deformation increases gradually under a constant load, the return of the material to its original state after the removal of the load is also gradual. Since the effect of this phenomena is similar to that of the friction between the plates in that it has a tendency to result in a higher reading for the applied load curve and a lower reading for the release load curve, it no

doubt has some effect upon the curves; however, as this effect is comparatively slight, it may be disregarded in this article. In the case of a semi-elliptic spring a small portion of this difference is perhaps due to the friction between the rollers or blocks upon which the ends of the spring rest and the table of the testing machine, although these surfaces were well lubricated. In all in-

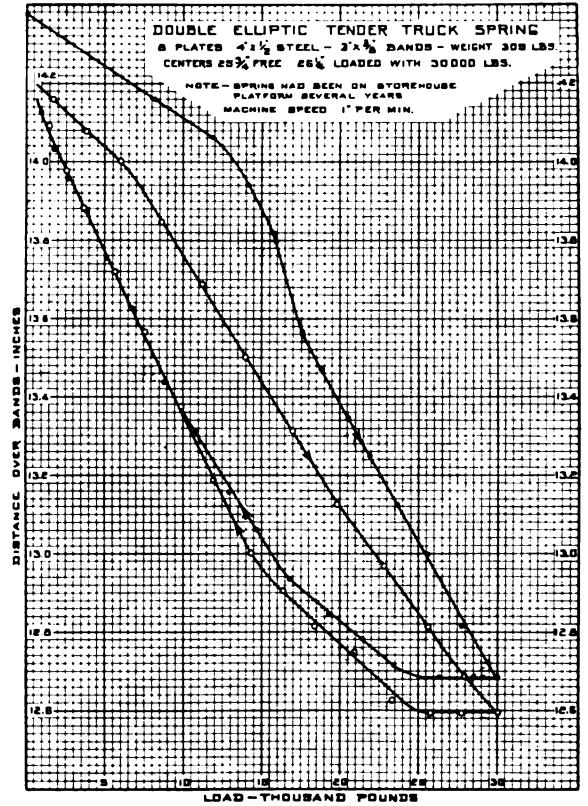

Fig. 4

stances the load increments were not of the same value. Should any one increment slightly exceed its preceding increment, any attempt toward equalization by removing the excess weight would result in a false value for the curves. In other words, it is to be borne in mind that once having applied a load to the spring, neither this load nor any portion of it should be removed until

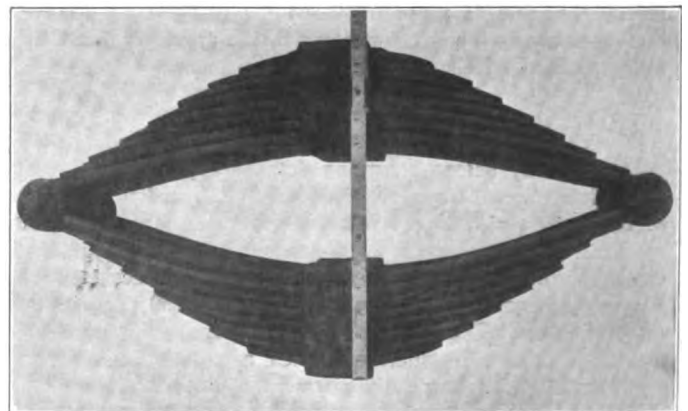

Fig. 5

it is desired to obtain values for the release load curve. Similarly, the values for the release load curve should be obtained only by the removal of the portion of the load and, in no case, should an attempt be made to equalize successive increments of the load by the addition of any amount whatever.

In order to determine the extent to which the different speeds of the testing machine affected the results, the curves shown in Fig. 3 were plotted, in this case the deflection of the spring in inches being taken as the ordinate instead of the camber. The spring chosen for these tests was selected at random from a number on the store house platform. It was tested with the result shown in curve A, but for the purpose in question, it was desired to have a spring with a minimum amount of friction and it was reset, retempered and the surface of the plates painted with a mixture of oil and graphite before being assembled. In this condition it was tested at three different speeds of the testing machine head: 1 in., $3\frac{5}{8}$ in. and $7\frac{5}{8}$ in. per minute as shown by curves C, B and D respectively. While there is some difference between these curves it is inappreciable so far as it relates to the purpose of the test and may be neglected. As a matter of fact, slight irregularities resulting in some instances, in differences as great as these have been encountered in verifying tests on the same spring.

The reader's attention is called to the important fact that the

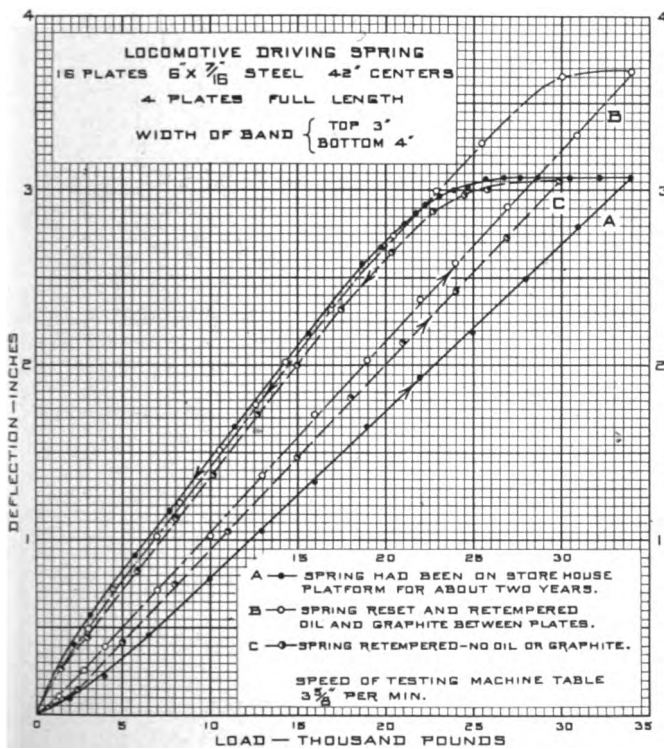

Fig. 6

values of the release load curves are much more uniform than those of the applied load curves.

In order to bring out clearly the necessity for the application of an initial load in testing springs before deflections are recorded the curves of a double elliptic tender truck spring are plotted in Fig. 4. As will be seen from the illustration of the spring in Fig. 5, it had accumulated a heavy coat of rust during several years of exposure on the storehouse platform, this condition serving to emphasize the point in question. The distance over the spring bands before the application of the first load was 14.37 in., and instead of following a straight line, as is usually the case, the applied load curve exhibits a decided hump. The release load curve is also irregular, but to a less degree, and does not return to the same initial point. On the second application of the load the results are more nearly uniform. In this case the release load curve returns to the initial point of the second applied load curve. In some instances as many as five applications of the preliminary loads are necessary to thoroughly limber up a spring and insure reliable results.

THE EFFECT OF FRICTION IN SPRINGS

For the purpose of showing the variations in the deflection of springs due to variations in the condition of the plate surfaces, the spring referred to in Fig. 3 was selected after having been exposed to the weather on an unsheltered storehouse platform for about two years. It was first tested just as it was found, and the result is shown by curves A on both Fig. 3 and Fig. 6. It was then reset, retempered, the surfaces of the plates painted with oil and graphite and re-assembled. The test curve then obtained is shown at B, Fig. 6, the same testing machine speed being used in both cases. At a load of 34,000 lb. the difference in deflection between the two application curves is .6 in., which may be attributed to the decrease in internal friction in the spring after resetting. The spring was again reset and retempered and assembled without lubricant between the plates. In this condition curve C, Fig. 6, was obtained. While the difference between the three release load curves is very slight, the maximum being about .1 in., a marked difference exists between the applied load curves. For a load of 20,000 lb. the difference in deflection between the spring in its original condition and when reset without oil and graphite between the plates is .27 in., or 15.6 per cent. With oil and graphite between the plates a further increase in deflection of .14 in., or 7 per cent was obtained. The total increase in deflection due to resetting and lubricating the plates was .41 in. or 23.7 per cent. The uniformity of the release load curves for wide variations in spring conditions is shown in Fig. 6.

[EDITOR'S NOTE.—The remainder of Part I will be published in an early issue.]

RECIPROCATING AND REVOLVING PARTS

BY H. A. F. CAMPBELL*

PART I (Concluded).

The valve motion parts of these Pennsylvania locomotives are shown in Figs. 14, 15, 16 and 17. It is not the intention to discuss each part in detail. Looking at the illustrations, these parts seem startlingly light. Every detail towards weight reduction has been carefully considered. Starting right with the pis-

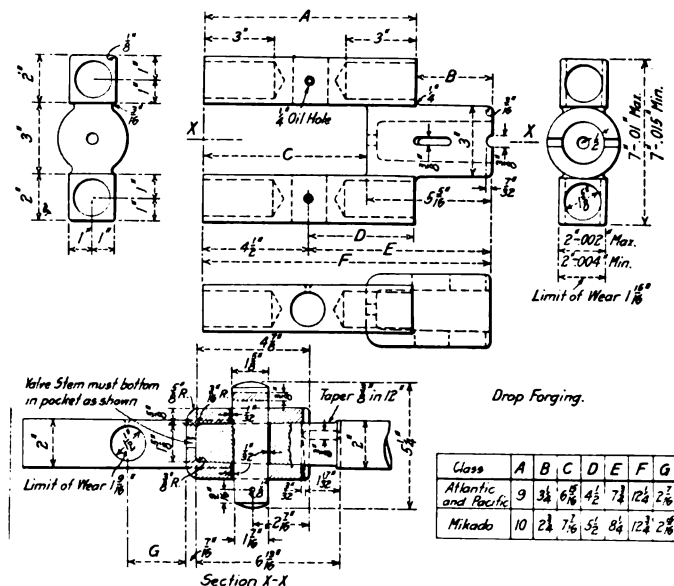
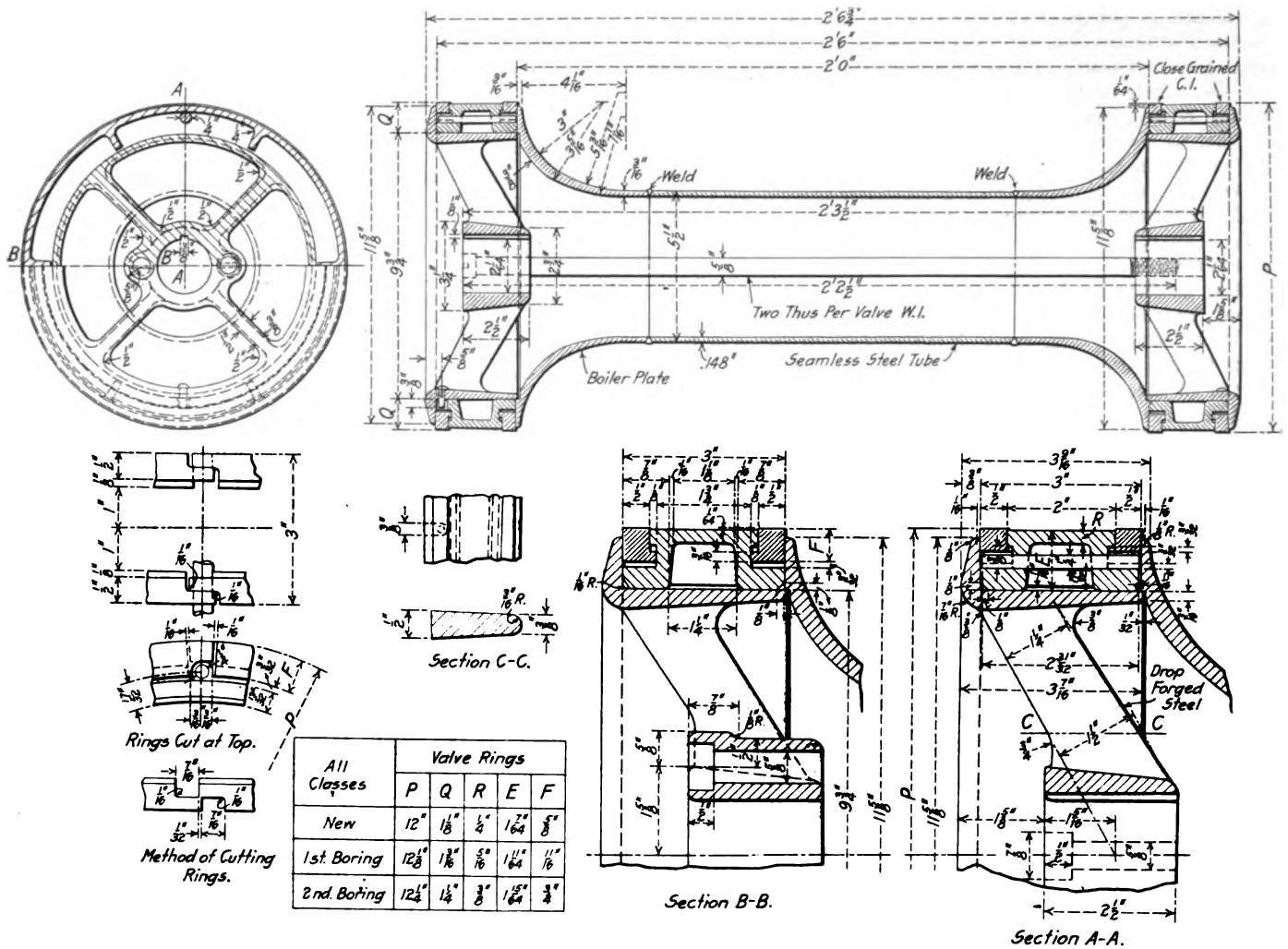

Fig. 14—Valve Stem Crosshead of Pennsylvania Locomotive

ton valve, the valve rod and valve rod crosshead, which are the main inertia parts, the weight has been greatly reduced over ordinary practice. All these parts may seem light, but as some of the principal stresses in them are caused by the inertia

*Baldwin Locomotive Works, Philadelphia, Pa.



All Classes	Valve Rings				
	P	Q	R	E	F
New	12"	13"	4"	16 1/4"	8"
1st Boring	12 1/8"	13 1/8"	5 1/8"	16 1/4"	11 1/8"
2nd Boring	12 1/4"	13 1/4"	3"	15 1/4"	3 1/4"

Fig. 15—Piston Valve Used on the Pennsylvania Locomotives

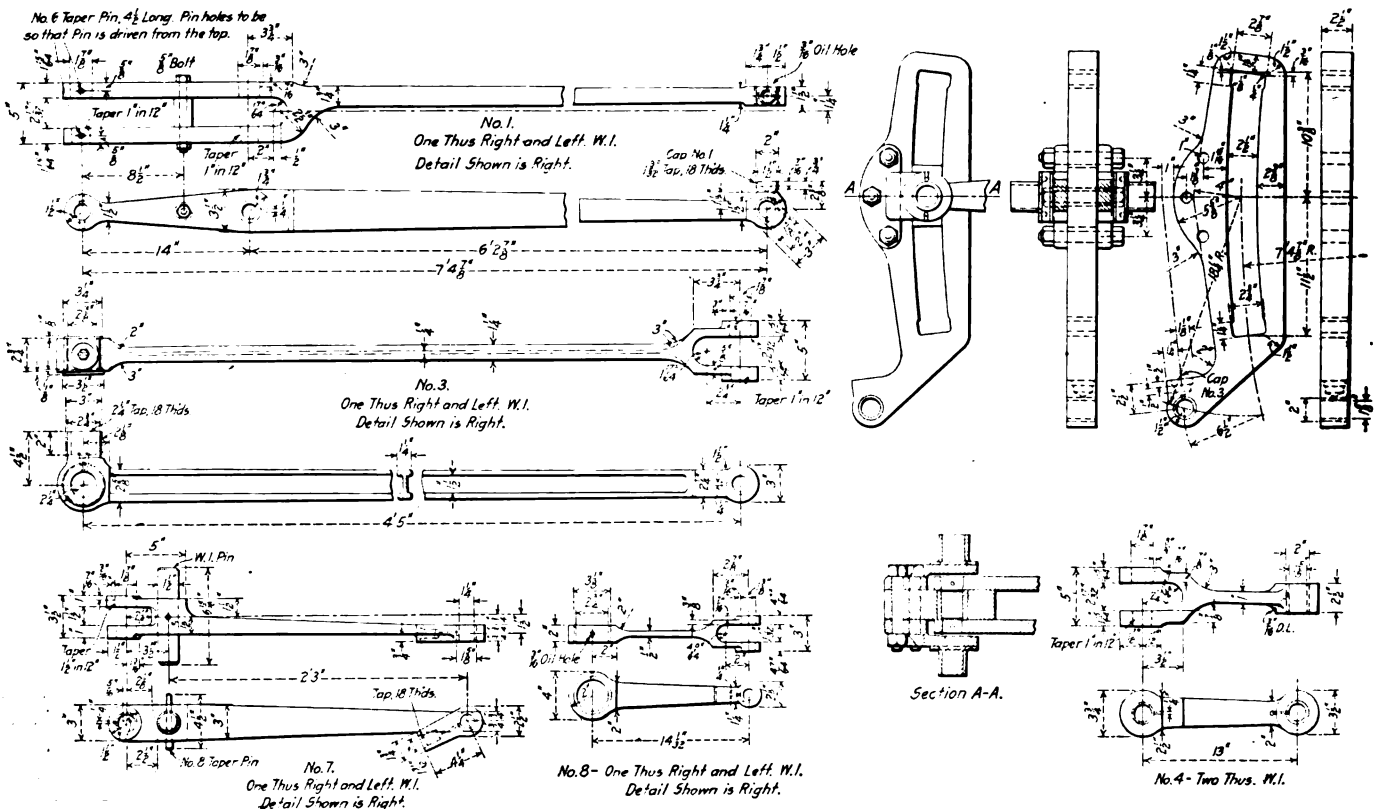

Fig. 16—Walschaert Valve Gear for Pennsylvania Pacific Type Locomotive

forces due to their own weight, it is evident that this very weight reduction has been one of the best safeguards against breakages. The bearing surfaces of some of the pins throughout the motion

valves have good lubrication, and the writer believes that the parts here illustrated will give every satisfaction.

The reciprocating and revolving parts designed for a 2-10-2

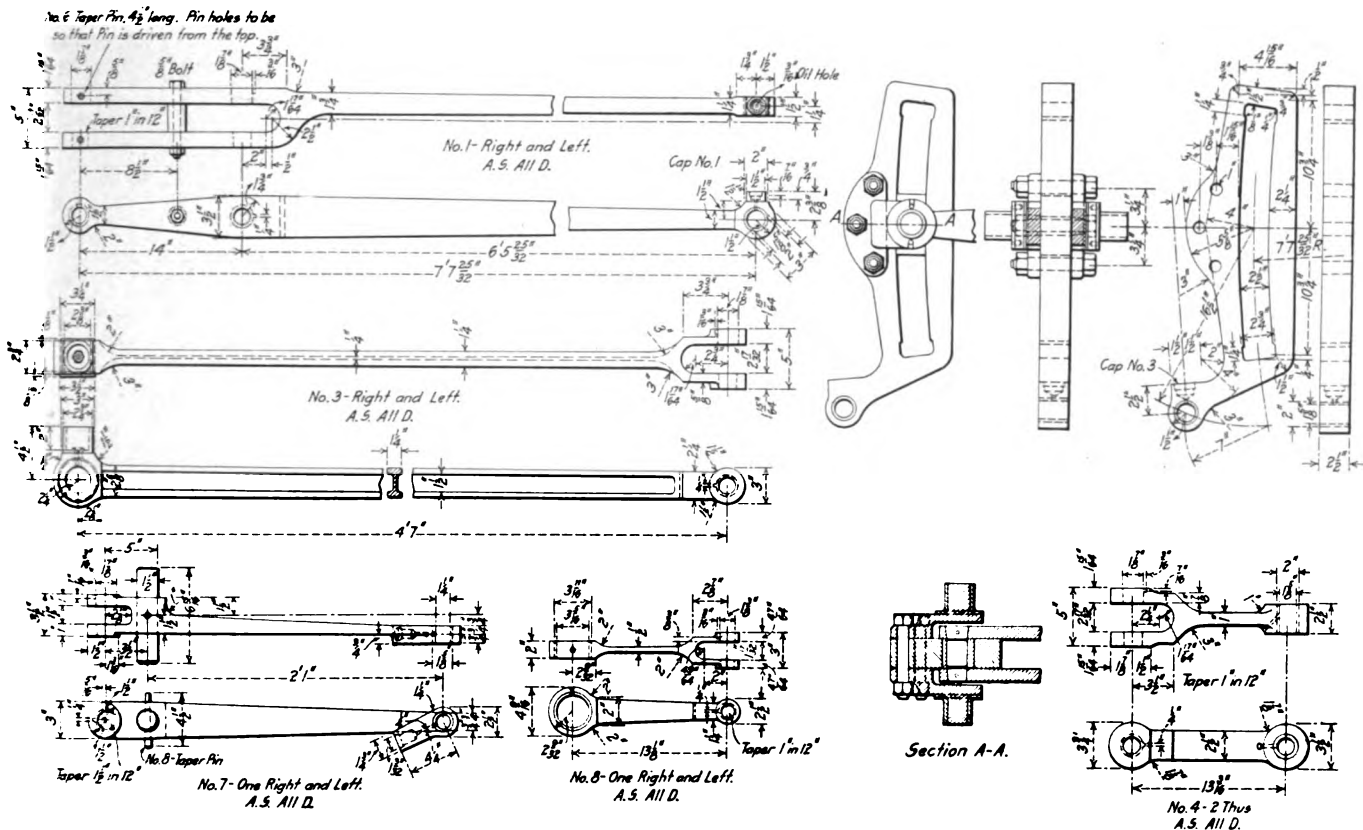

Fig. 17—Walschaert Valve Gear for Pennsylvania Atlantic Type Locomotive

seem very small, but are probably not too small when we consider the reduced pressures that come on them.

It may be remembered that the Pennsylvania Railroad purchased one of the French four-cylinder DeGlehn compounds. This engine had unbalanced valves, but the valve motion parts

type freight locomotive built in 1914 by the Baldwin Locomotive Works for the Chicago, Burlington & Quincy, will next be considered. The railroad already had one engine of this class and size, the cylinders being 30 in. by 32 in., the drivers 60 in. in diameter, the boiler pressure 175 lb., and the weight on drivers

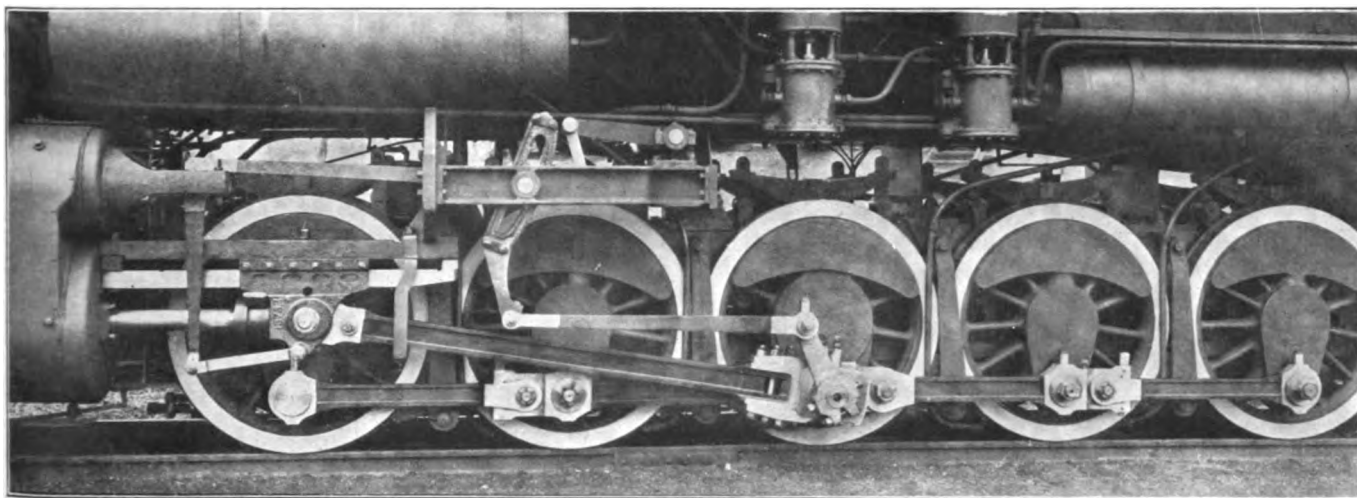

Fig 18—Running Gear of Chicago, Burlington & Quincy, 2-10-2 Type Locomotive

were very light and the writer heard it authoritatively stated that after the engine had made a certain mileage it was carefully examined and it was found that the wear of the valve motion parts was absolutely nothing. The wear of the valve motion parts is mostly caused by their own weight, assuming that the

300,000 lb. The main drivers were several hundred pounds light as to counterbalance, even in balancing the revolving weights, and two counterweight bobs weighing 1,500 lb. each had been placed on the main axle between the boxes. This made the dead weight on the main drivers excessive. The railroad company

asked the Baldwin Locomotive Works to design two locomotives of a duplicate order of ten engines without the counterbalance bobs on the main axle, and to use alloy steel for the piston rods, connecting rods, stub straps, pins and eccentric cranks. The pistons and crossheads were to be lightened as much as possible. It was decided to use nickel-chrome steel, annealed, with an ultimate strength of 100,000 lb. per square inch, a yield point of 70,000 lb. per square inch and an elongation of 23 per cent.

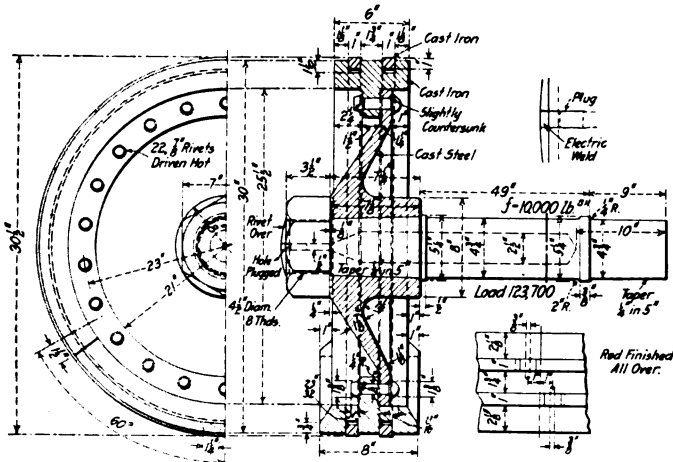

Fig. 19—Piston and Rod for Burlington Locomotives

This was found impossible to obtain. Nickel-chrome carbon steel, oil tempered, was finally used and had the following properties:

Carbon	0.38 per cent	Ultimate tensile strength,	96,000 lb. per sq. in.
Manganese	0.50 per cent	Yield point.....	70,000 lb. per sq. in.
Silicon	0.026 per cent	Ultimate compressive strength	(assumed)
Nickel	1.27 per cent	Elongation	25 per cent
Chrome	0.28 per cent	Reduction in area.....	62 per cent

The piston and crosshead were made of 0.4 carbon cast steel, carefully annealed, with an ultimate tensile strength of 80,000

less excess weight, and the total weight of the reciprocating parts was reduced 16 per cent.

Fig. 19 shows the piston and piston rod. The piston is made

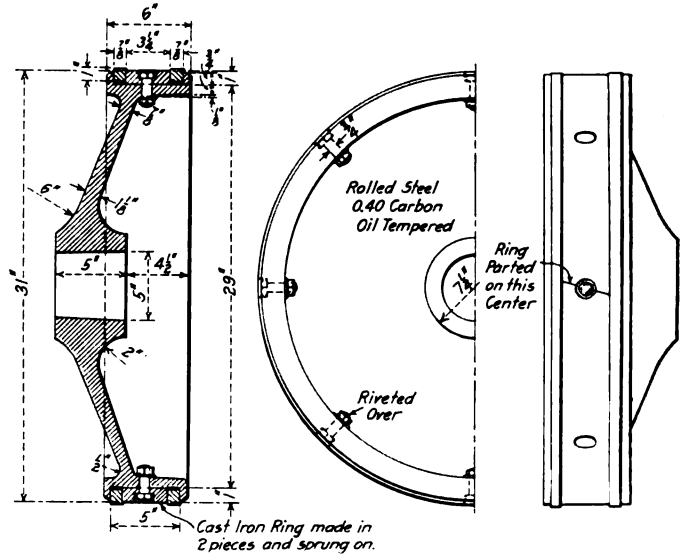

Fig. 21—Another Redesign of the Burlington Piston

of 0.4 carbon cast steel, annealed; a cast iron bull ring is used. The piston rod is of nickel-chrome steel, hollow-bored and then

TABLE IX—SAVING IN WEIGHT IN RECIPROCATING PARTS OF BURLINGTON 2-10-2 TYPE LOCOMOTIVES

Name of part	Weight, in lb., of		Weight saved, lb.
	Carbon steel parts	Nickel-chrome parts	
Piston and piston rod.....	1,022	945	77
Crosshead	706	526	180
Main rod	1,305	1,035	270
Side rod on front pin.....	150	117	33
Side rod on intermediate pin.....	482	352	130

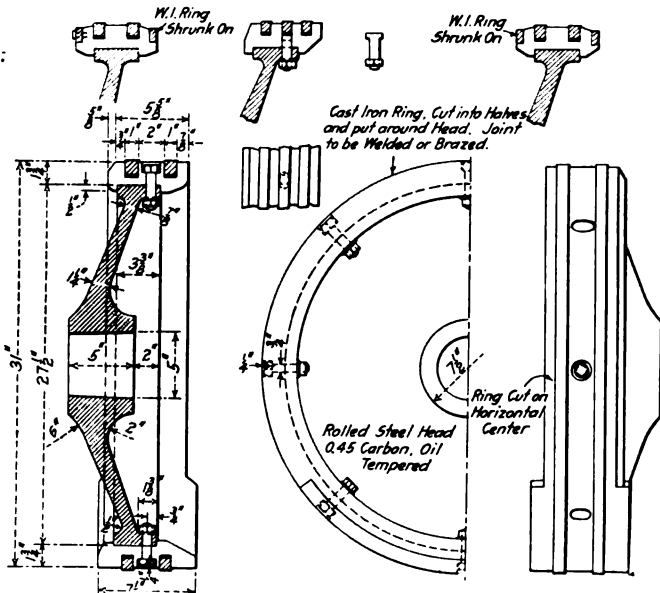

Fig. 20—Burlington Piston Redesigned

lb. per sq. in., yield point 50,000 lb. per sq. in., and elongation 22 per cent. An idea of the appearance of these parts may be obtained from Fig. 18. The results obtained in weight reduction are given in Table IX. The counterweight bobs were omitted from the main drivers and the weight at the rail on the main drivers was reduced from 67,000 lb. to 62,000 lb. The main wheels without any bobs were better balanced vertically by 35 lb. The forward, back and intermediate wheels have very much

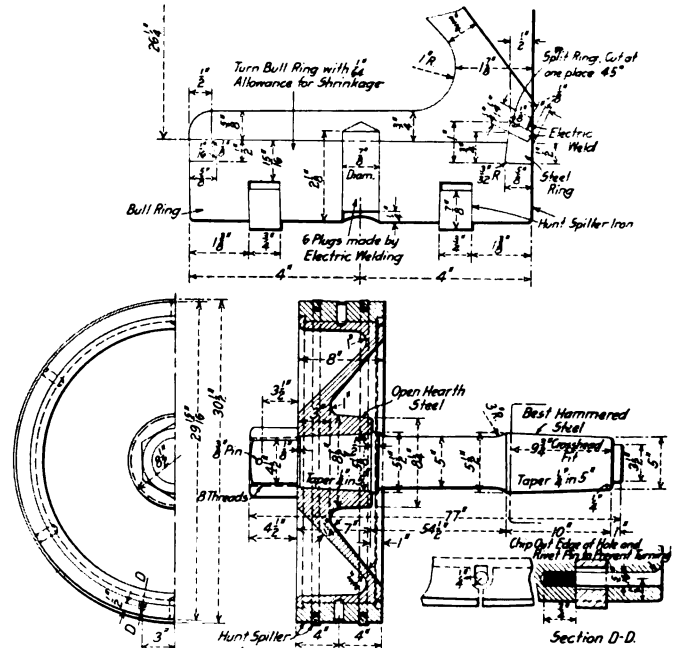

Fig. 22—Pressed Steel Piston with Cast Iron Wearing Shoe

Side rod on main pin.....	718	577	141
Side rod on intermediate pin.....	476	388	88
Side rod on back pin.....	150	111	39
Main crank pin.....	360	325	35
Eccentric crank	160	125	35

oil-tempered, and an extension piston rod is not used, so that a cast iron wearing ring seemed necessary.

The piston shown in Fig. 19 is not as light as it could have been designed and ample strength still retained. Figs. 20 and 21 show this piston redesigned and considerably lightened. The piston rod is not to have an extension tail rod, and the piston is to be made of rolled open hearth steel of 0.45 to 0.50 carbon and

This is a light piston but is expensive to make and fit up. Fig. 23 shows a 30 in. piston head of the hollow box type with a cast iron wearing shoe sprung in or cast on. This head is to

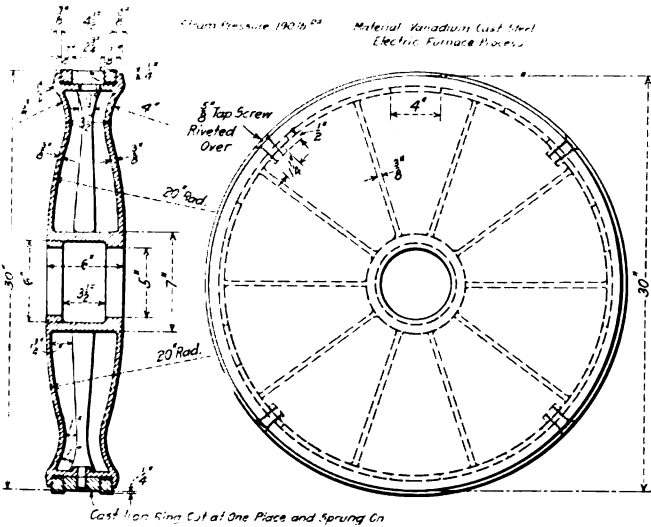

Fig. 23—Hollow Box Type Piston

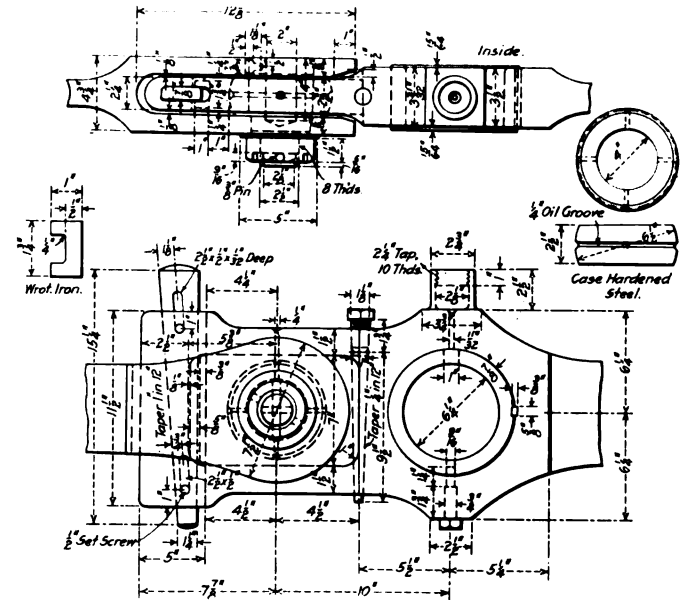

Fig. 25—Side Rod Stubs of Burlington Locomotives

oil tempered. The wearing shoe is of cast iron with lips on the outside; this ring will be made in one piece, then parted by one cut and sprung around the head and welded or brazed where it was cut. Eight 3/4-in. bolts help to hold the shoe to the pis-

be made of vanadium cast steel with an ultimate strength of 90,000 lb. per sq. in., and to withstand 190 lb. boiler pressure. This head, with only 3/8 in. walls, is to be cast by the electric furnace process, and the manufacturers state that it is well

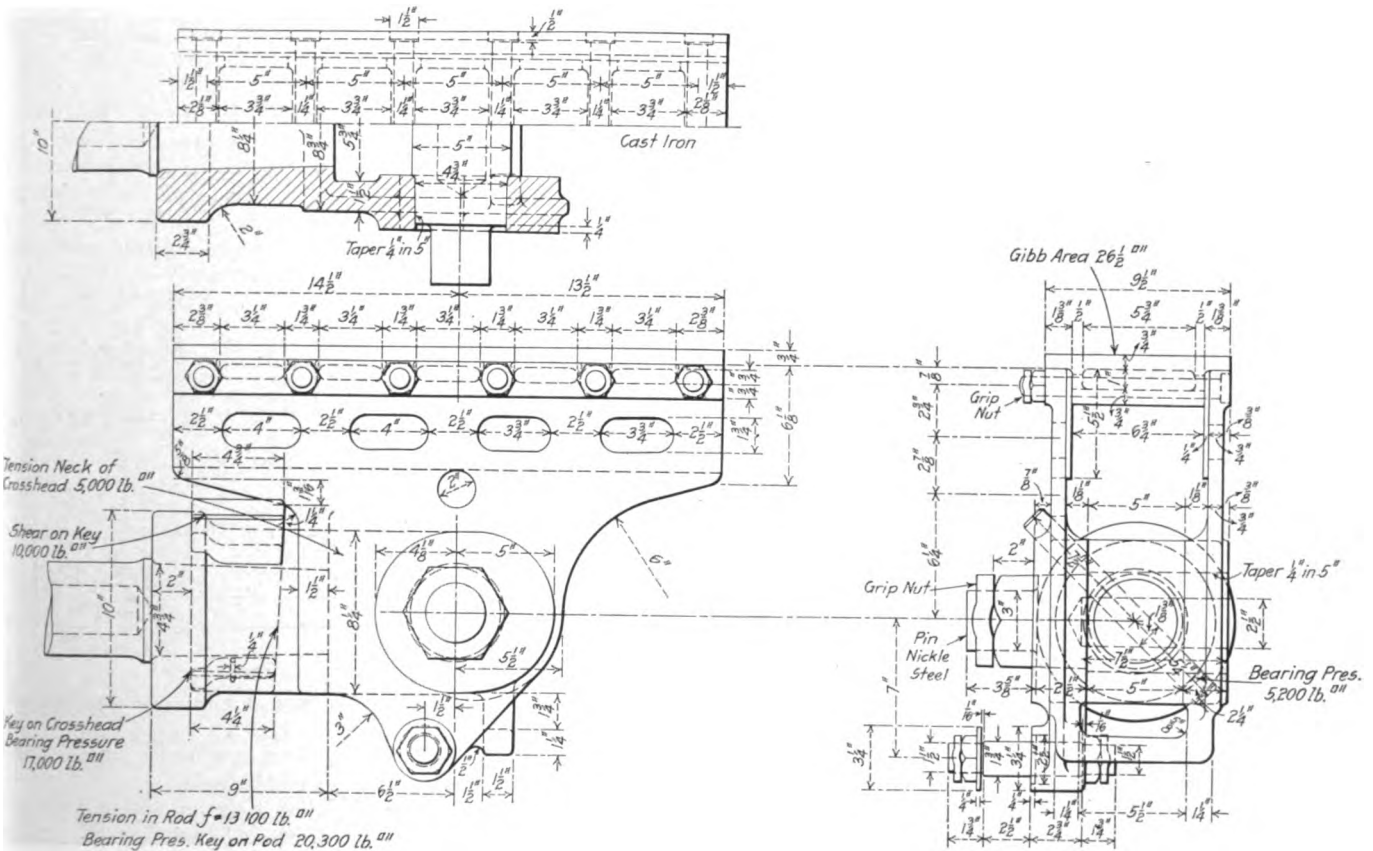

Fig. 24—Crosshead Used on the Burlington 2-10-2 Type Locomotives

ton, although it is a question whether these are needed after the shoe is once put on and the ends brazed together.

Fig. 22 shows a pressed steel piston head 30 in. in diameter, that has a cast iron wearing shoe, held by a retaining ring.

within their possibilities. This piston, complete with rings, weighs only 250 lb.

Fig. 24 shows the crosshead of the Burlington engines. This is made of .4 carbon cast steel annealed, the ultimate tensile strength

being 80,000 lb. per sq. in. A cast iron wearing gib is used. The Laird type of crosshead with two bar guides was decided on, as for large freight engines it was found that this was the lightest type obtainable. Many railway men are not in favor of this type of crosshead, but it has been successfully used on many freight and passenger locomotives, some of the freight locomotives being of very high power. On many European railways it is standard, especially on passenger engines.

It will be noted that a small lug has been cast on for the pin

The connecting rods of the Burlington locomotives are shown in Fig. 26. I section main and side rods have been used and the bearing pressure on all the pins kept fairly low. The main side rod connection is of the strap type with wedge adjustment, this arrangement being used in order to keep the bearing pressure low on this pin. As the diameter of the crank pin increases and the periphery speed of the brass on the pin also increases, the bearing pressure on these large pins should be kept even lower than has been done in this case. The stub straps are of

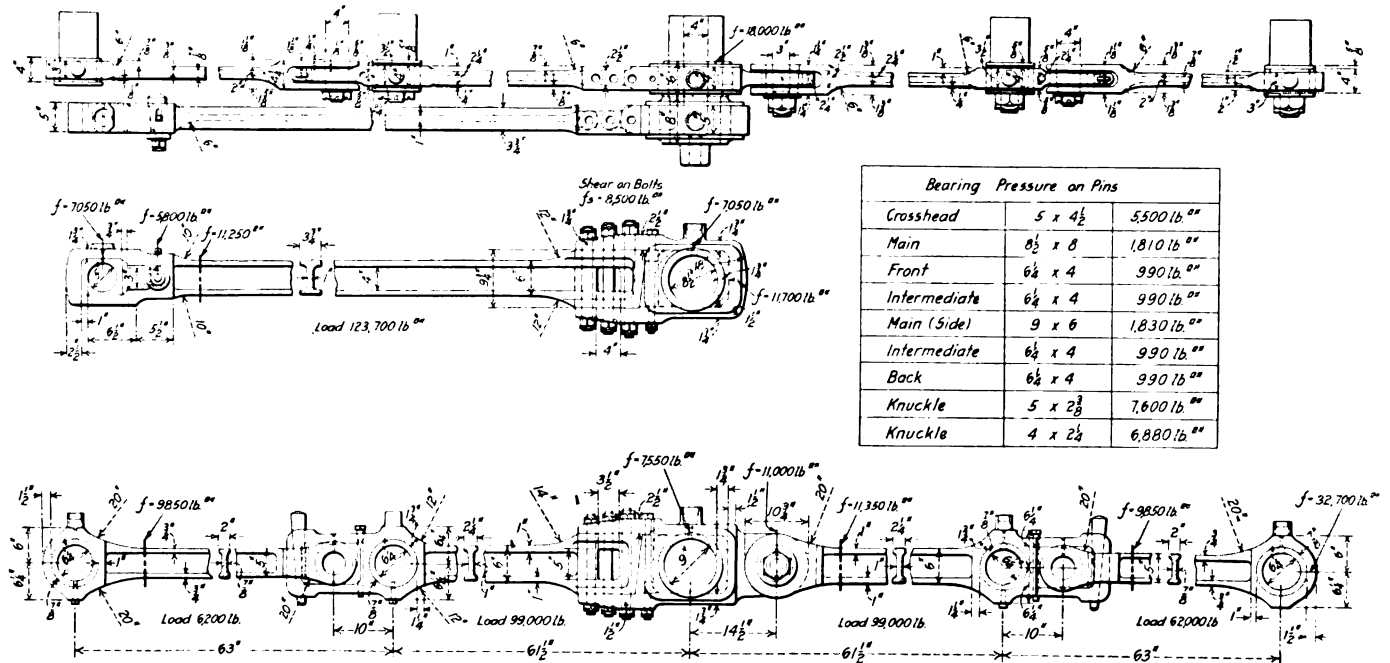

Fig. 26—Connecting Rods of the Burlington Locomotives

for the combining lever. It was decided to do this because it was thought that the crosshead pin had enough to do without driving the valve motion, and also because the length of the combining lever required this particular location. A large crosshead pin has been used, and ample bearing surface provided for the pin in the crosshead itself.

The stresses on the various sections are given in table X.

nickel-chrome, oil-tempered steel and are light. The stubs on the main pin, although of the strap type have had every pound of unnecessary weight removed and are very light in relation to the work performed. The stresses in the different sections are given in table XI, based on the main rod load equal to the area of the piston multiplied by the full boiler pressure and a pro-

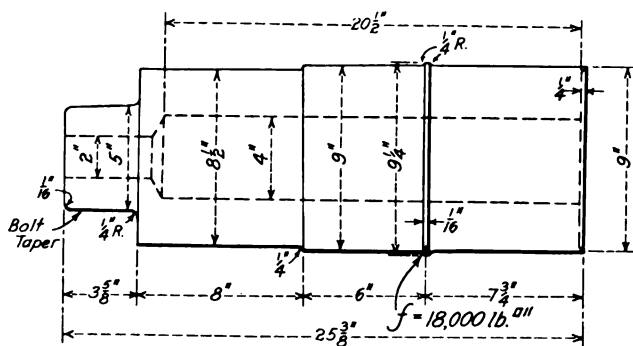

Fig. 27—Main Crank Pin of Burlington Locomotive

portional load on the side rods, 50 per cent on the front and back rods and 80 per cent on the two middle rods.

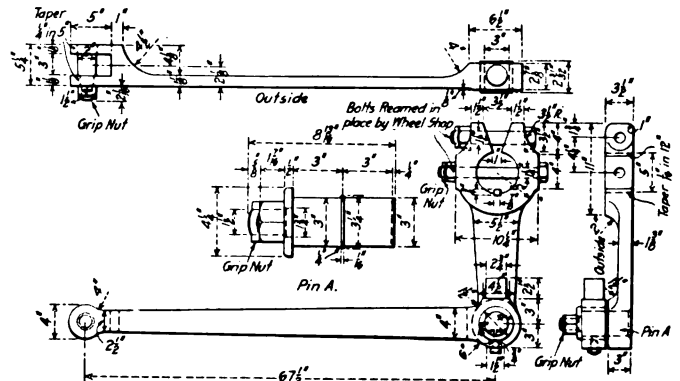

Fig. 28—Eccentric Crank and Rod of Burlington Locomotive

TABLE X—STRESSES IN CROSSHEAD OF BURLINGTON 2-10-2 TYPE LOCOMOTIVES

Section	Lb. per sq. in.	
	Stress	Usual allowable stress
Shear on key	10,000	9,000
Tension in rod through keyway	13,100	10,000
Tension in neck of crosshead through keyway	5,000	3,500
Crushing of key on rod	20,300	17,000
Crushing of key on crosshead	17,000	15,000
Bearing pressure, pin on crosshead	5,200	5,500
Compression in main shank of piston rod	10,000	8,000

The intermediate knuckle pin is large in diameter and has ample wearing surface. The front and back knuckle pins are of the ball pin type. This type of stub is clearly shown in Fig. 25. When this style of ball pin is used, it is the writer's belief that greater stresses may safely be used in the rods. This style of pin has been running some years and has given every satisfaction.

The I sections of both the main and side rods are of a design

not much used by other American designers. The rods are narrow and heavy webs are used. It is thought that the narrower the original slab from which the rod is made the sounder every part of it is forged; then instead of cutting away and leaving

to the driving wheel design—the style of rim, the spokes and hub—some weight was taken off the unbalanced hub portion and a few pounds added to the counterbalance where this weight counted most.

Reference has been made to the difficulty of keeping the bearing pressure low on large crank pins on account of the periphery speed of the brass increasing as the diameter of the pin is increased, and in this connection Fig. 29 shows another style of

TABLE XI—STRESSES IN MAIN AND SIDE RODS OF BURLINGTON 2-10-2 TYPE LOCOMOTIVES

Section	Stresses, lb. per sq. in.	
	Alloy steel	Carbon steel, Not heat treated
Main rod, I section.....	11,250	8,000
Crosshead stub strap.....	7,050	6,000
Crosshead stub strap at set screw.....	5,800	6,000
Main rod stub, tension.....	8,500	8,000
Main rod stub, bending.....	11,700	14,000
Side rod (front and back) I section.....	9,850	8,000
Side rod (intermediate) I section.....	11,300	8,000
Stub (front and back) eye, tension.....	6,000	6,000
Stub (front and back) eye, bending.....	32,700	20,000
Main side strap, tension.....	7,500	6,000
Main knuckle eye, tension.....	11,000	6,000
Intermediate stub eye, tension.....	7,900	6,000
Intermediate knuckle eye, tension.....	7,500	6,000

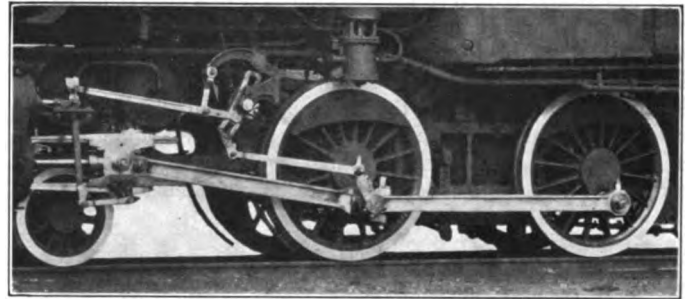

Fig. 30—Running Gear of Philadelphia & Reading, 4-4-0 Type Locomotive

only a very thin web in the middle of the rod, which is the least worked part of the steel, enough metal is left to provide a substantial and solid web.

It must not be thought that this style of rod is any heavier than the slimmer and wider one, because each has the same stress and therefore the same cross-sectional area. As a strut in compression, where the ratio of length to the least radius of gyration — does not exceed 160, actual tests on full sized sections have shown that this type of rod is just as strong as the

main stub and brass. The Chesapeake & Ohio had great difficulty in keeping the main pins cool on their Mountain type locomotives, which originally had the usual strap and wedge stub. This new stub is solid, with no key adjustment and a steel bushing is pressed into the solid end and held by steel plugs at the top and bottom. The brass is a loose bronze ring and revolves on the pin and in the bushing; this reduces the velocity of the

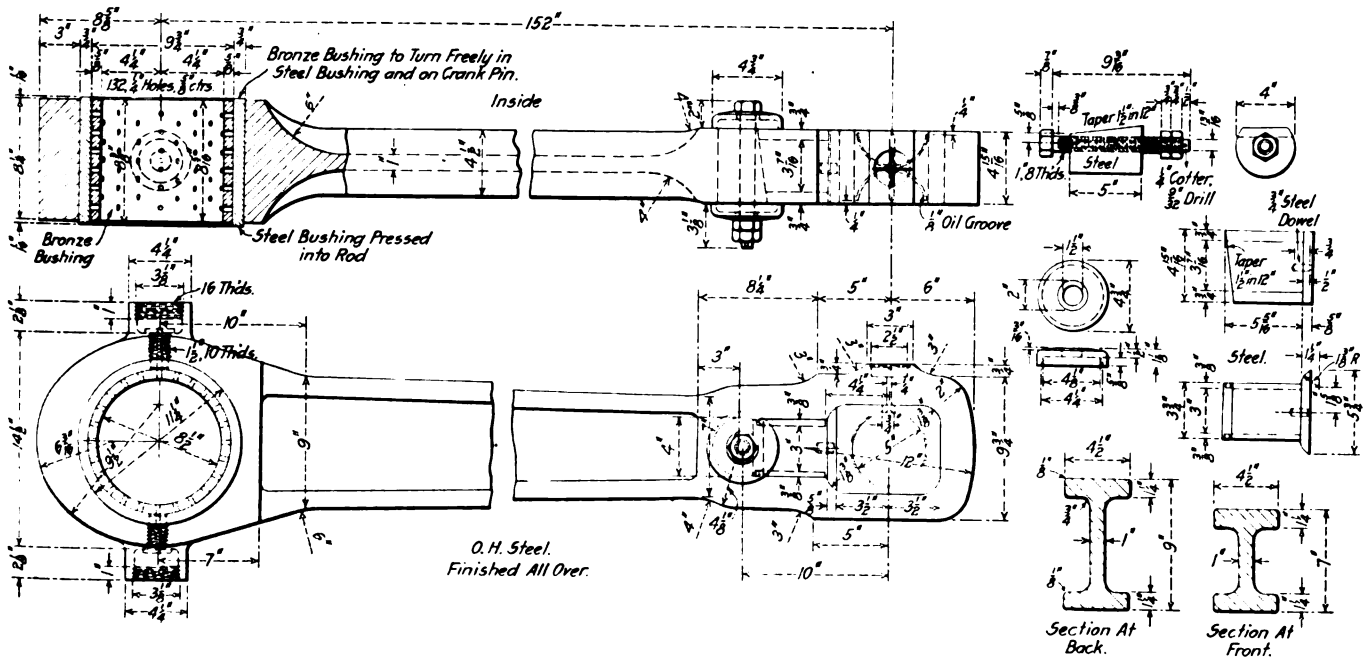

Fig. 29—Main Rod Used on Chesapeake & Ohio Mountain Type Locomotive

wider and slimmer one. It is the writer's belief that this type of rod will withstand the varied stress conditions better than any other section.

The main crank pin, Fig. 27, is of nickel-chrome steel, hollow bored and then oil tempered. The fiber stress in this pin in bending is not high considering the fine quality of the steel. As a matter of fact the outside dimensions of the pin were determined by the bearing pressure. A larger hole could have been bored out of this pin and the fiber stress still kept within safe limits.

The eccentric crank and eccentric rod, Fig. 28, were lightened, but not as much as they might have been. By careful attention

brass by one-half. The pin is oiled by a series of holes in the brass, grease plugs, top and bottom, being used. J. R. Gould, superintendent of motive power of the Chesapeake & Ohio, states that this style of stub has been in operation two years and has given satisfaction.

Fig. 30 shows a Philadelphia & Reading 4-4-0 type passenger locomotive, ten of which were built by the Baldwin Locomotive Works in 1914 to the company's designs. It is believed that these are the heaviest eight-wheel engines ever built. Special attention was given to the design of the reciprocating and revolving parts and all the valve motion parts. It is not intended to go into their design in detail, but the illustration shows clearly

that all these parts, and especially the valve motion work, are light.

AN X-RAY INSPECTION OF A STEEL CASTING*

BY DR. WHEELER P. DAVEY
Research Laboratory, General Electric Company

It has always been true that as soon as a new tool is perfected unsuspected applications of that tool rapidly develop. This has been especially true in the case of the Coolidge X-ray tube. Possibly the question of observing the "pipe" in a steel ingot by the use of the X-ray, thereby being able to determine just where the ingot should be cropped, may seem still somewhat removed, at least in so far as commercial applications are concerned. There is no inherent impossibility in the process how-

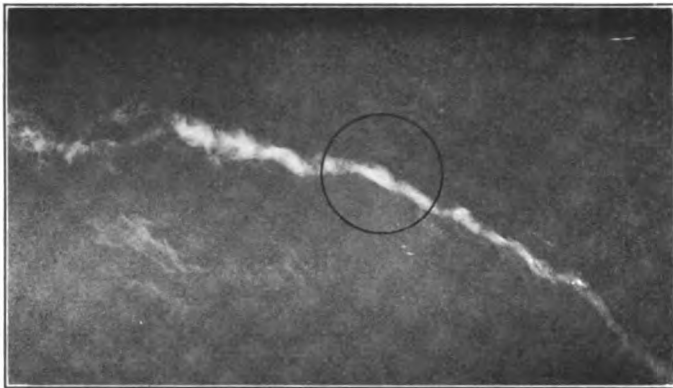

Fig. 1—Radiograph of Steel Casting Showing a Blow Hole Below the Surface. The Circle Shows Where the Button Was Removed

ever. The case now being described is a long step in this direction. It is the object of this article to describe in detail what has already been done in the way of an X-ray examination of a certain steel casting of which suspicion had been aroused as to its homogeneity when in the machine shop.

The original casting was $2\frac{1}{2}$ in. thick and weighed about a ton. When received at the Schenectady works of the General Electric Company it had been machined down to approximately the desired shape and thickness. The amount still to be taken

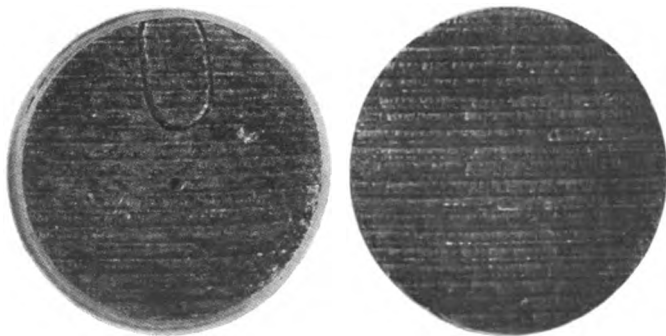

Fig. 2—Machined Surfaces of the Button Removed from the Point Shown in Fig. 1

from the faces was not more than $\frac{1}{8}$ in., and in some places was only $\frac{1}{16}$ in., but when this was removed it was found that some small imperfections had been cut into. These extended over an area about 5 in. long and $1\frac{1}{2}$ in. wide. The mechanical department at once chiseled away a part of the surface at this point, and then sent the casting to the research laboratory to determine if, by means of an X-ray examination, it might be

possible to reveal still other hidden blow holes or imperfections.

A Coolidge tube especially made for use on high voltages was set up in front of that part of the casting where the imperfections had been found. An 8-in. by 10-in. Seed X-ray plate was mounted immediately behind the casting and the plate was backed by a large sheet of lead. The distance from the source of X-ray to the plate was 20 in. The tube was excited by an induction coil with a mercury-turbine interrupter. The current through the tube was 1.25 milli-amperes and the potential across the terminals of the tube corresponded to that sufficient to break down a 15-in. spark gap between needle points. The X-ray plate was exposed two minutes. At the place where the radiograph was taken, the finished casting was about $\frac{9}{16}$ in. thick. After a radiograph had been obtained at the point where the imperfections were discovered, the casting was moved 8 in. and another radiograph made. In this way a number of exploratory radiographs were taken through different points of the casting.

All the radiographs thus taken showed plainly the tool marks on the surface of the casting. All but one showed peculiar markings, which were of such shape as to strongly suggest that



Fig. 3—The Ends of the Blow Hole Passing Through the Button

they were indeed the pictures of holes in the interior. A circular piece, 1 in. in diameter, was punched from the casting at a point where one of the radiographs indicated that a blow hole should be found. A reproduction of this radiograph is shown in Fig. 1, and the point at which the punching was taken is indicated by the circle. An examination of Fig. 2 shows that the surfaces of the casting were entirely free from blow holes at the point where the button was removed. Fig. 3 shows the ends of the hole in the button.

This has proved, then, that with the proper X-ray exposure, blow holes or cavities may be disclosed in apparently solid metal of considerable thickness. A careful comparison of the X-ray photographs and the button photographs leads to the conclusion that very small air inclusions are made visible; and the fact that the tool marks are plainly visible on the X-ray plate confirms this.

RELATIVE EFFICIENCY OF STEAM, GAS AND OIL ENGINES.—Roughly stated, a first-class modern steam engine utilizes about 12 per cent of the available heat in the coal, resulting in, say 1.6 to 1.7 lb. of fuel per b.hp.hr. during a week's work of 55 hours. If the boilers are to be fired by producer gas, for which purpose slack and dust can be used, then each brake horsepower will require about 2 to 2.2 lb. of coal. Internally fired gas and oil engines are approximately twice as efficient as steam engines, which means that they utilize about 25 per cent of the available heat. Crude oil being 37 per cent better than good ordinary coal, oil engines should use only about three-eighths as much oil as the coal mentioned above, say about 0.6 lb. per b.hp.hr. Then, however, as there are no boiler radiation losses over night, a material saving results and the oil consumption per week of 55 hours may be about 0.5 lb. per b.hp.hr. Petrol and similar internal combustion engines would require about 0.4 lb. per b.hp.hr. Gas engines have also the same efficiency as oil engines, but as there is a loss of about 20 per cent in the producers, if these work day and night, and another loss of quite 10 per cent if they have to stand idle over night, the efficiency of gas engines is only about 40 per cent better than that of first-class steam engines.—*Power*.

*Abstract of an article appearing in the January, 1915, issue of the General Electric Review.

CAR DEPARTMENT

THE DEFECTS OF MODERN BOX CARS AND THEIR REMEDIES*

BY ROBERT N. MILLER

Instructor in Mechanical Engineering, Carnegie Institute of Technology, Pittsburgh, Pa.

The proper strengthening of box car underframes is in itself a subject worthy of serious consideration, owing to the ever increasing demands placed upon the underframe. As a result of the introduction of larger and more powerful locomotives, the cars of weaker design have been gradually retired to the cripple shop to be reinforced or, where damage has been too great, to be scrapped. With this gradual elimination of the weaker type and the substitution of still stronger types has arisen the question as to what shall be considered a proper standard for the strength of box cars. This question is one of great import, for in it are involved questions concerning first cost, depreciation and maintenance, and interlocking with these the questions pertaining to durability, protection of lading and the cost of hauling the dead weight over the line.

Aside from the question of first cost of equipment can be considered that phase of economical construction in which more stress is laid upon durability, maintenance and protection of lading than upon first cost, depreciation and cost of haulage of dead weight and therefore on the basis of equal revenue ton-miles we could consider the extremely heavy construction on one side of the balance against the extremely light construction on the other side, with the most economical type of construction somewhere between the two. After all, railway operation is a matter of dollars and cents and in these days of rigid economies and retrenchments it should be the aim of managements to safeguard the future by investing only in such forms of equipment as give the lowest final cost and not, as is more often the case, in designs which are low in first cost but high in maintenance and depreciation.

It is of course to be admitted that in cases of new types of construction figures are not always available showing the cost of maintenance or of actual depreciation of these newer types, due to wear and tear, and therefore it may be argued that at best we can but resort to the method of cut and try in determining which type of construction is the more economical. However, by a constant study of yearly costs of depreciation, maintenance and haulage of dead weight, based on revenue ton-miles made by the car, we can soon observe whither the drift of costs is carrying us. This is, of course, assuming that no one type of car has been favored to the detriment of the others.

With this end in view, after a series of observations covering a period of several years of the performance of various types of construction used in freight equipment, the writer concludes as follows:

UNDERFRAMES

The average freight car of today, whether of high or low capacity, does not possess an underframe of sufficient strength to withstand repeated stresses due to loading of the car and due to end shocks or jerks received in train handling or in hump yard service. In order to prove this we have only to visit the cripple yard to observe the more common repairs made there. Many center sills can be found which, while they are of ample section area in the gross to withstand end

shock, still, due to defective design in the distribution of this area, or in the splicing at the draft sills or at the riveting of the tie or web plates of the body bolsters or crossbearers to the center sills, have been so badly mutilated with rivet holes as to render them practically useless as tension members capable of resisting the jerks incident to the starting of trains or to undesired quick action from the rear of the train when moving at slow speeds.

That center sills are often weaker as tension members than as compression members can be seen by inspection of the many forms of so-called steel center sill cars, in which the center sill can be considered as a form of the continuous draft gear officially declared obsolete. In this case one may find as high as 25 to 30 per cent of the full section of the sill removed through rivet holes for either coupler lugs or tie and web plates at the bolsters or crossbearers, or at the draft sill splices to the center sills. Not only has the net area of the center sill been seriously reduced, but what is of greater consequence, the resisting section modulus of the center sill has been impaired to a far greater extent. It can therefore be seen that the matter of the most efficient type of riveting arrangement is one which warrants careful attention in order that the center sill sections shall be most efficient.

Again, where center sill construction employs draft sill splices to center sills at some point between the end sill and the body bolster, the section areas of the draft sills are often purposely made less than that of the center sill proper so as to localize the weakest member of the center sill construction. However, it appears that in the attempt to safeguard the center sill itself, the draft sills have been made entirely too light, with a result that due to repeated shocks in both alternate tension and compression the draft sill fatigues, weakens and finally fails along the path of least resistivity, namely, at the rivets. Inasmuch as the great majority of draft sill splices are of the chain riveted type it is believed that a decided improvement can be affected at this point by the use of the staggered form of riveting. This would also in a way apply to the riveting found at the bolster and cross-bearer connections to the center sills.

Where underframes are spliced at the draft sills the splice riveting should be given particular attention with a view to a design such that the section modulus of rivet areas or the rivet shearing moment shall be at least equal to the net resisting moment or section modulus of the draft or center sill. A study of the splicing commonly found at draft sills develops that many are weak at this point, so that while the shearing areas of the rivet sections appear sufficient for a direct shear, yet they are entirely inadequate to resist shear due to combined eccentric and direct draft gear loads, with a result that those rivets less favorably located with respect to their neutral axis are the first to fail, either by working loose, shearing or tearing out. The fact that these rivets pound loose proves the rivet section of improper design.

It has been recommended before the Master Car Builders' Association that for cars built after 1913 the area of the center sills should exceed 24 sq. in. and that the ratio of end stress to strain should not exceed 0.06, as shown by the formula:

$$0.06 > \frac{1}{A} + \frac{X}{S_m}$$

Where A = center sill section area;
X = eccentricity of resultant draft gear load about the neutral axis;
S_m = section modulus of sill section.

This formula is directly applicable to constructions where

*Entered in the car department competition which closed October 15, 1914.

the center sill is not used to support the car lading, as would be the case in the true side frame types of construction. However, where the center sill is, in addition to acting as a column member, subjected to a transverse bending due to the nature of the loading, the additional stress due to the maximum transverse bending moment at any point under consideration should also be included; so that where M represents the resultant maximum bending moment due to loading, being plus or minus, according as it is in the same clockwise direction, or not, as the draft gear bending moment, then the equation becomes:

$$0.06 ES > \frac{M}{S_m} + \left(\frac{1}{A} + \frac{X}{S_m} \right) ES$$

where ES is the value of end strain or draft gear load.

The question as to whether the net value of A (sill area) and S_m (section modulus) are to be used depends entirely upon the matter of the direction of the maximum bending moment and the direction of the force ES . If the indications are that the section is more unfavorable to a tension force ES , then of course the net values are to be used, otherwise full section values could be employed. As a matter of fact, however, the writer believes it better to err on the side of net areas rather than to attempt to decide just where tension and compression cease in the section. Under an end load ES , equal to 400,000 lb., the maximum permissible working fibre stress in the center sill would be 24,000 lb. per sq. in. This fibre stress is equivalent to a factor of safety of about two when based on the elastic limit of the material used.

DIAGONAL BRACING OF UNDERFRAMES

The present tendency in the bracing of body bolsters and crossbearers against longitudinal movement at the outer extremities seems to be toward the elimination of all diagonal braces except those from the outer ends of the end sill to a point forward of the body bolster. These have been retained in order to permit poling of the car through the pole pockets and also to reinforce the underframe against serious damage in the event of the car being cornered. This elimination of diagonal bracing can be considered as satisfactory from an engineering point of view, provided bolsters and crossbearers each have sufficient lateral rigidity to bear their portion of impact loads along the line of the underframe without distortion, and with this in mind each crossbearer or bolster should be so designed that the resultant fibre stress due to vertical bending under direct loading, plus that due to lateral bending through inertia of loading, does not exceed a predetermined value of 20,000 lb. per sq. in. Therefore, not only should the section moduli of the crossbearers and bolsters be considered with reference to vertical bending, but they should also be considered with reference to lateral bending, so that:

$$\frac{M}{S_x} + \frac{KM}{S_y} = \text{or } < 20,000 \text{ lb. per sq. in.}$$

Where M = the vertical bending moment on each arm of crossbearer due to lading;

- K = inertia factor due to sudden change in speed of car;
- S_x = section modulus of net section of crossbearer with reference to the horizontal axis;
- S_y = section modulus of net section of crossbearer with reference to the vertical axis.

The factor K can be derived as follows:

- Let V_1 = initial speed of moving body in miles per hour;
- V_2 = final speed of moving body in miles per hour;
- d = distance, in feet, in which the speed has been changed from V_1 to V_2 ;
- K_1 = average force acting upon one pound of the moving body to change the speed from V_1 to V_2 in distance d ;
- $K = 2 K_1$, or value of a force ranging from zero to a maximum K , with average equal to K_1 .

Then on the basis of each pound of moving weight:

$$K_1 d = \left(\frac{V_1^2 - V_2^2}{2g} \right) \times \left(\frac{22}{15} \right)^2 = 2.15 \left(\frac{V_1^2 - V_2^2}{2g} \right)$$

$$\text{or } K_1 d = (V_1^2 - V_2^2) \times .0334$$

$$K d = 0.0668 (V_1^2 - V_2^2)$$

$$= 0.07 \times (V_1^2 - V_2^2), \text{ approximately,}$$

$$\text{or } K = 0.07 \left(\frac{V_1^2 - V_2^2}{d} \right)$$

By means of diagonal bracing to the extremities of the crossbearers to take care of inertia loads in either direction, the crossbearer sections need then only be designed for vertical bending with the diagonal ties or struts to resist the lateral bending, in which case the net section of the diagonal tie as a tension member can be shown as:

$$\text{Area} = \frac{KM}{20,000 \times l \cos \alpha}$$

- Where K = inertia factor;
- M = vertical bending moment due to load;
- l = length of crossbearer arm in inches;
- α = angle which the diagonal makes with the center sill.

In cases where the diagonal is used as a strut the section of the strut should be determined from the column formula:

$$\frac{KM}{l \cos \alpha} = \frac{20,000 \times A}{1 + \frac{r^2}{36,000 l^2 \sin^2 \alpha}}$$

In which r = least radius of gyration of strut section.

The use of diagonal members to brace the crossbearers also subjects the latter to an additional direct tension or compression of:

$$\frac{KM \tan \alpha}{l \times A}$$

This should be combined algebraically with the stresses due to vertical bending and the final resultant fibre stress should not exceed the 20,000 lb. limit.

CENTER SILL CASTINGS AND DETAILS

Where sills or members are coped out to afford clearances for lever floats, piping, etc., the sections at these points should be designed to give proper equivalent section moduli and owing to the frequency of failures at these points particular attention should be paid to these structural details. Castings used as fillers or reinforcement over the center plates should be designed to meet shocks due to the inertia of trucks, as well as to afford reasonable access for riveting, so that the center plate can be firmly secured to the underframe, thereby eliminating one of the most prolific causes of cars being thrown off center or center sills damaged through lack of proper bearing upon the center plates.

The draft sill members of center sills should also be securely tied at the top and bottom of the sills and especially back of the rear draft lugs, to prevent spreading of the draft sills under the draft gear loads.

END SILLS

The end sill member has received very little attention and many cars can be seen in daily service where it is so coped out at the center or draft sill as to render it well nigh useless as a load resisting member. It is believed, where circumstances permit, that end sills should be superimposed upon the center sills so as to render them most efficient in resisting cornerwise blows and also to resist those inertia loads coming from the end reinforcement members of the body end framing.

SIDE AND END FRAME

Where a steel side frame is used the members should be designed to meet not only stresses due to the dead weight of the car body and the car loading, but also the horizontal loads due to the inertia of the various car frame members and the lading. Especial attention should be given to the riveted connections of the frame members so as to obtain

connections of maximum efficiency for the loads to be sustained. The matter of lateral pressure or bending on the members of the superstructure should be considered with respect to the various commodities to be carried in the car. This lateral pressure warrants particular attention at the end reinforcement members, for one can observe unlimited instances where these end members have been designed entirely too light or weakened through cutting out for clearances, such as for uncoupling attachments, with the result that the end of the car soon assumes a spherical contour due to the effect of load shifting.

In connection with this matter before the Master Car Builders' Association it has been further recommended that end reinforcement members (not including corner posts) should have a section modulus equal to $(15 \text{ in.})^3$ at a point 2 ft. above the car floor, or practically equivalent to four 7/16 in. by 4 in. Z-bars. It has been further noted that such designs as have end reinforcement equivalent to the above recommendations experience very little trouble from bulged-out ends and this in itself should be ample indication that the recommendation is sufficient to meet present-day requirements.

Side frames at the door openings should be of sufficient strength in both top and bottom chord members to resist the combined stresses due to transverse bending and direct load and with the corners of the opening thoroughly gusseted to prevent distortion of the rectangular opening. When a car is provided with large end doors, as in those built for automobile service, special attention should be given to the locking attachments of these doors, so as to provide a removable type of end reinforcement of ample strength to resist such load shifts as are to be met in grain service.

ROOFS

When wooden frame cars were in more general use than at present the design of roof was such as would permit of a certain degree of flexibility, so as to accommodate itself to the weaving or twisting action of the car body while rounding curves or passing over uneven track. The feature of flexibility is still largely adhered to in steel side frame cars, and appears to have been more or less overdone in this case. Where steel side frames are employed and where they are of proper design to carry the loads imposed, one may observe no appreciable weaving of the car frame while passing over track inequalities; the whole car body or frame acts as a compact unit. In view of this fact, together with the difficulties inherent in sectional roofing, it would appear that a more logical type of roof would be that in which roof sheets (either rust-proof or anti-corrosion steel) are securely riveted together and to the roof carlines, thus tying the side frame and carlines into one rigid unit capable of withstanding mechanical strain. This would lead us to a type of continuous roof such as can be found on steel passenger equipment.

It is further believed that when the roads are sufficiently interested in the preservation of their steel equipment from corrosion, by the use of anti-corrosion paints or rust-resisting steels, we may expect to find a more general introduction of the all-steel car roof and finally the all-steel box car, which can be considered the "ultima thule" to which car builders are turning.

CONVENTIONS AT SAN FRANCISCO.—Up to the present more than 400 national and international congresses and conventions have chosen San Francisco as the 1915 meeting place, including 25 educational conventions.—*Iron Age.*

PSYCHOLOGY IN MACHINE DESIGN.—The man who remarked while standing in line waiting at a box office that he would rather walk two miles than stand five, expressed an important fact that we should keep in mind in designing machines. The human being must neither be unduly restricted in his freedom of action nor overtaxed with hard work.—*James Hartness.*

BOX CAR END DOOR

BY GEORGE E. McCOY

The lower rail end door illustrated below has recently been adopted by the Canadian Government Railways and applied to a number of 40-ton steel frame box cars. As shown in the engraving, the center line of the opening is located 21½ in. above the floor of the car and the door is operated inside the car. The door frame is a one-piece steel casting, the flange of which is secured to the outside by means of bolts

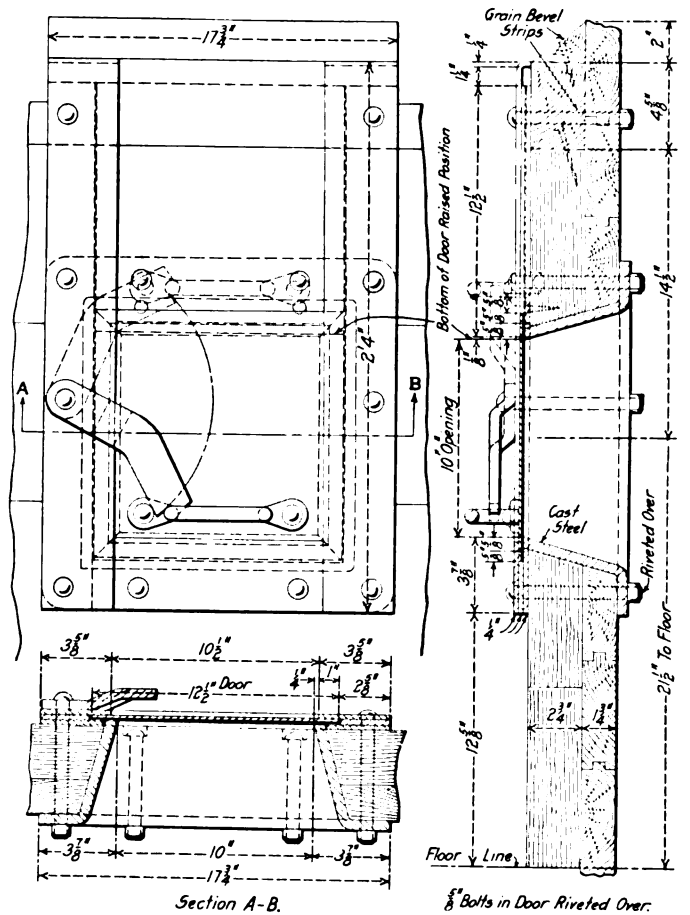

Lower Rail End Door, Canadian Government Railways

passing through the end of the car. The opening is tapered and is 10 in. square next to the door on the inside. The opening is closed by a steel plate which slides vertically in guides inside of the car. When closed the door is locked by means of a strut, the free end of which drops into position against the handhold near the bottom of the door and when open it is held up by the same device. Cars fitted with this type of door have been in service for some time with excellent results.

BLOCK SYSTEM ON HAULAGEWAYS.—In the main underground haulage way maintained by the Bunker Hill & Sullivan mine, through the Kellogg tunnel, two miles long to the shaft, an electric block signal system has been installed and has been in successful operation. This consists of a special circuit of colored lights strung along the tunnel throughout its main haulage length in one-mile sections, operated by the motorman through a lever that can be thrown conveniently at the end of each block. Red lights are used in one direction and green lights in the other, and the motormen are prohibited from entering a block carrying the opposite colored light until it is extinguished and shown to give them a clear track for a mile in length.—*Engineering & Mining Journal.*

GRAND TRUNK SUBURBAN COACHES

Steel Frame Construction Employed With Wood Reinforcement and Wood Finish; Weight 137,000 lb.

The Grand Trunk recently placed in service a number of suburban coaches, which are of particular interest from a number of standpoints. They are 83 ft. 3¼ in. long over buffers, 74 ft. long over body end sills and weigh complete, ready for

two trucks (40,000 lb.) to the car body, preventing the body from turning over in case of derailment; third, the full effects of the air brake can be obtained under all conditions, even after a derailment, as each truck is held in position under the car.

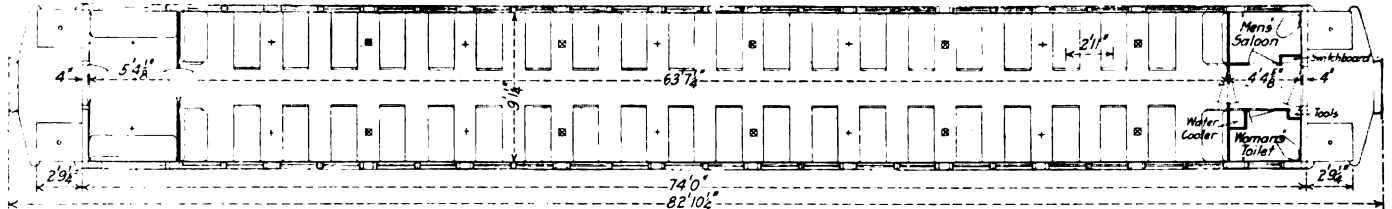

Floor Plan of New Grand Trunk Suburban Car Which Seats 96 Passengers

service, with six wheel trucks equipped with rolled steel wheels, 137,000 lb.

The framing is of steel construction with all steel vestibule, the interior and exterior finish being of wood. This construction is the result of much study and consideration, with the object in view of obtaining a construction which offered a maximum of safety and comfort to the traveling public, and a minimum expense to the railway company for maintenance. This problem seems to have been successfully solved by the adoption of a steel underframe and steel side framing, equivalent in strength to a steel car, in addition to which the car body and truck are locked together, so that the braking force is effective in stopping the car body as well as the trucks in case of derailment or collision. By the introduction of this truck and body bolster locking device,* and adopting all steel vestibules, the possibility of telescoping is believed to be practically eliminated. The locking device is designed to have a three-fold function, in case of wreck or derailment: first to prevent telescoping; second, to lower the center of gravity by adding the weight of

By installing steam heat and electric light the car is rendered practically fireproof. The railway officers concluded after careful investigation that the passengers' wearing apparel, the

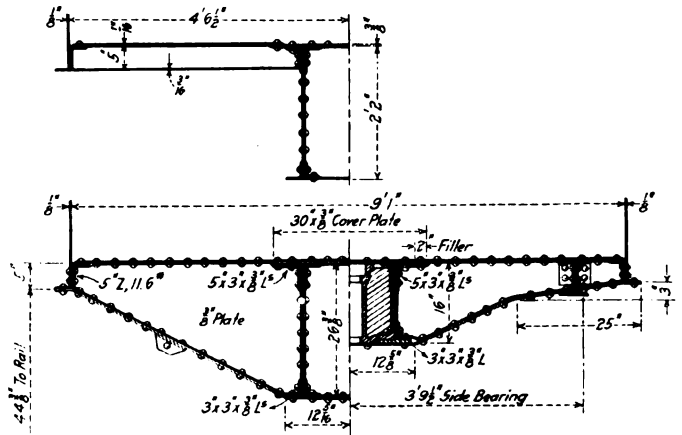

Cross Sections of the Underframe

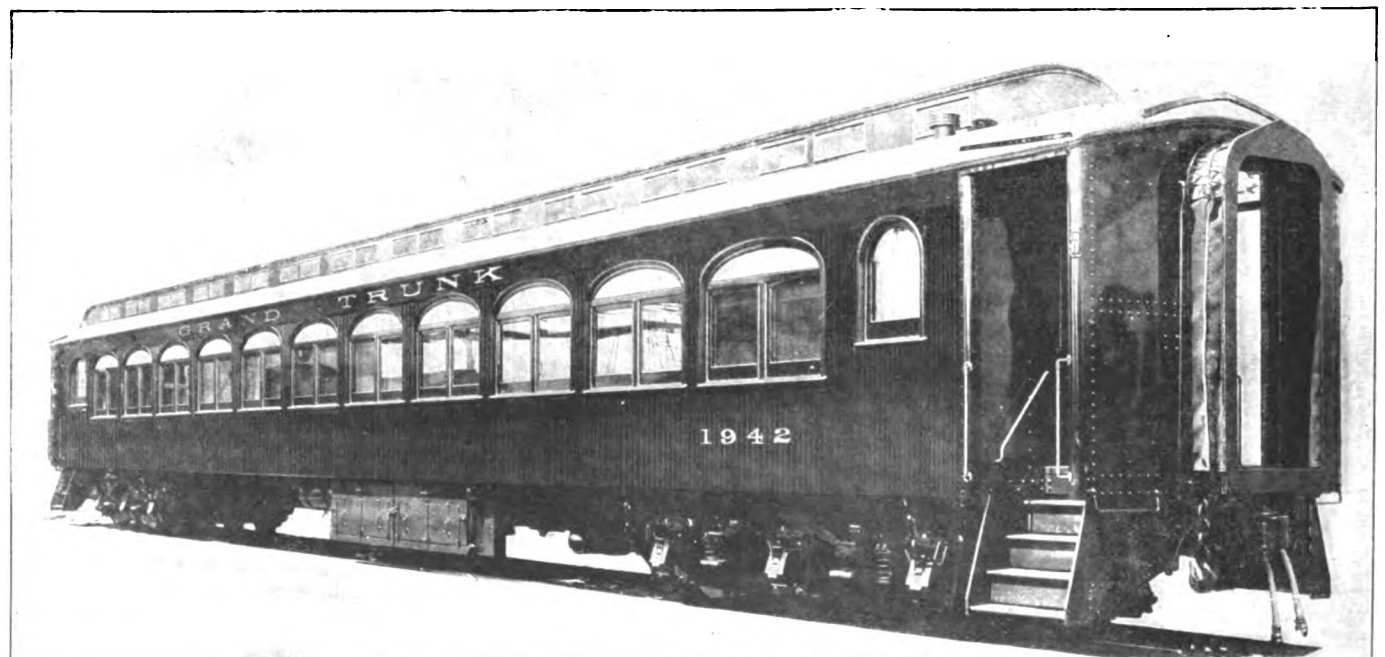

Steel Frame Suburban Car with Wood Finish Recently Placed in Service on the Grand Trunk

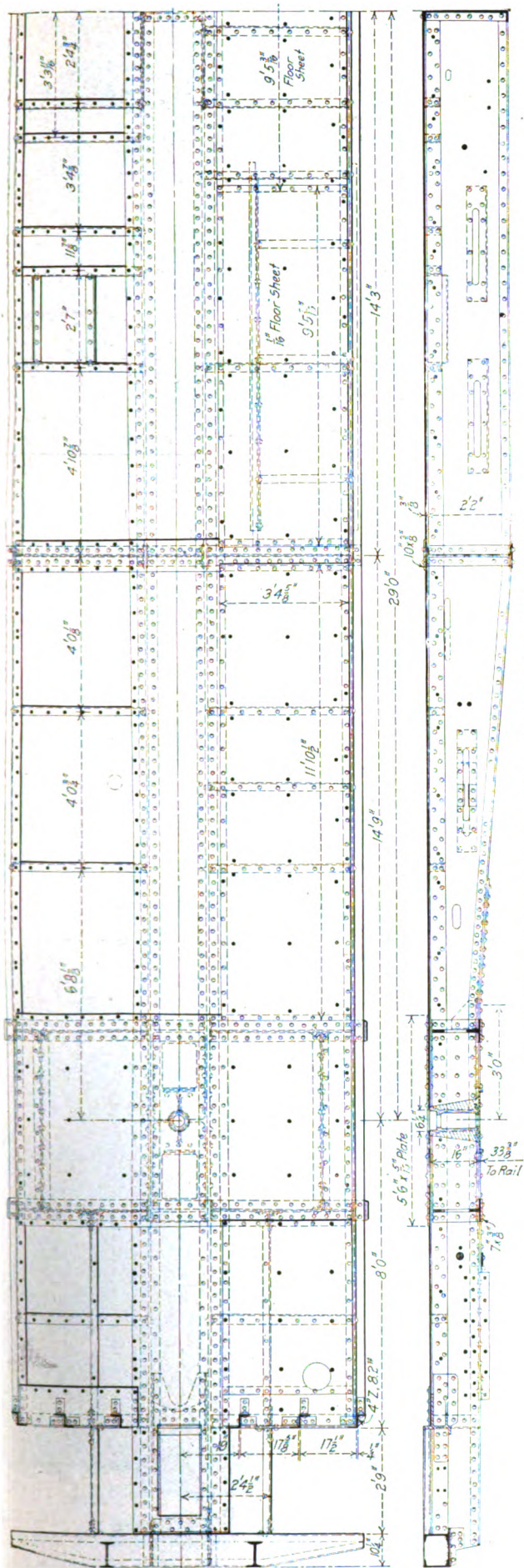

General Arrangement of the Underframe of the Grand Trunk Car

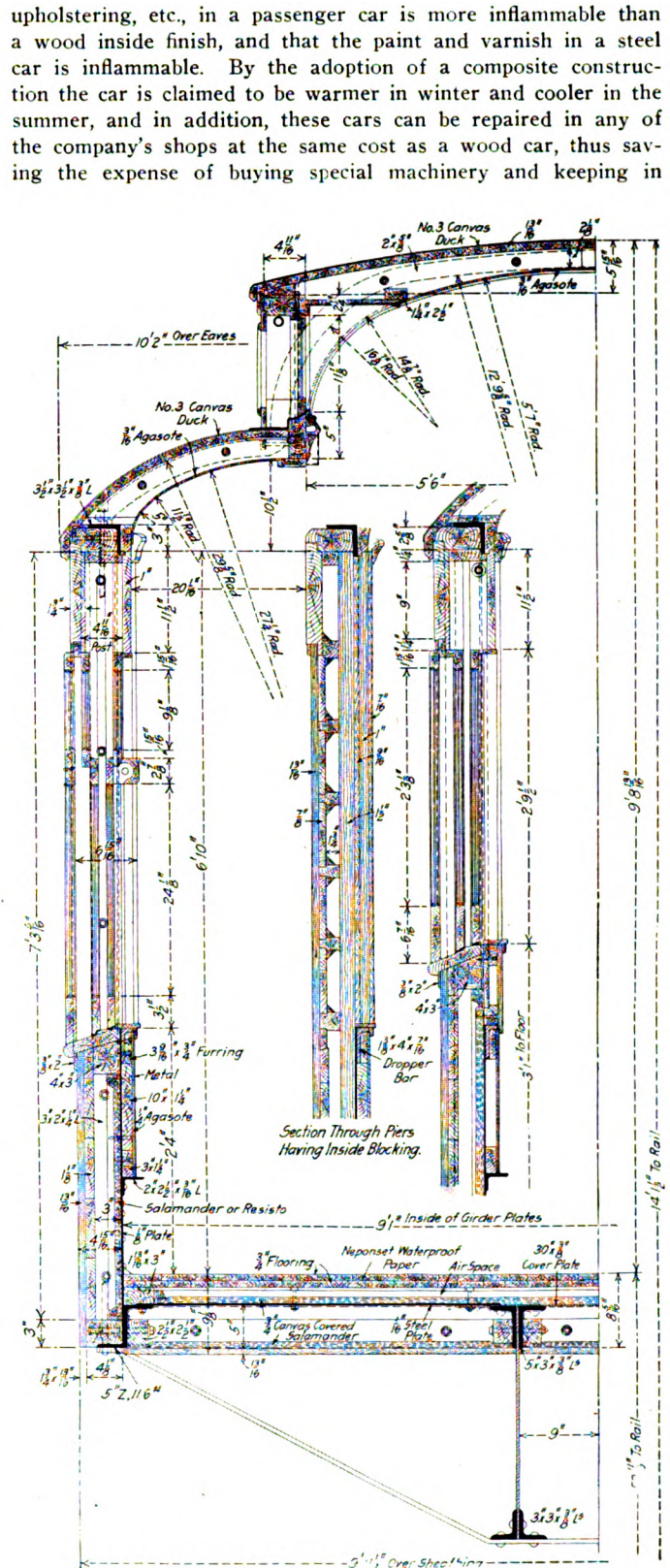

Cross Sections of the Grand Trunk Car

upholstering, etc., in a passenger car is more inflammable than a wood inside finish, and that the paint and varnish in a steel car is inflammable. By the adoption of a composite construction the car is claimed to be warmer in winter and cooler in the summer, and in addition, these cars can be repaired in any of the company's shops at the same cost as a wood car, thus saving the expense of buying special machinery and keeping in

stock special material for repairs, which would be necessary with steel interior and exterior finish.

UNDERFRAME

The underframe is constructed with the center sills as the principal members. They are of the built up fishbelly type, continuous from buffer beam to buffer beam and consist of a 30 in. by 3/8 in. top cover plate, 5 in. by 3 in. by 3/8 in. top angles, 5/16

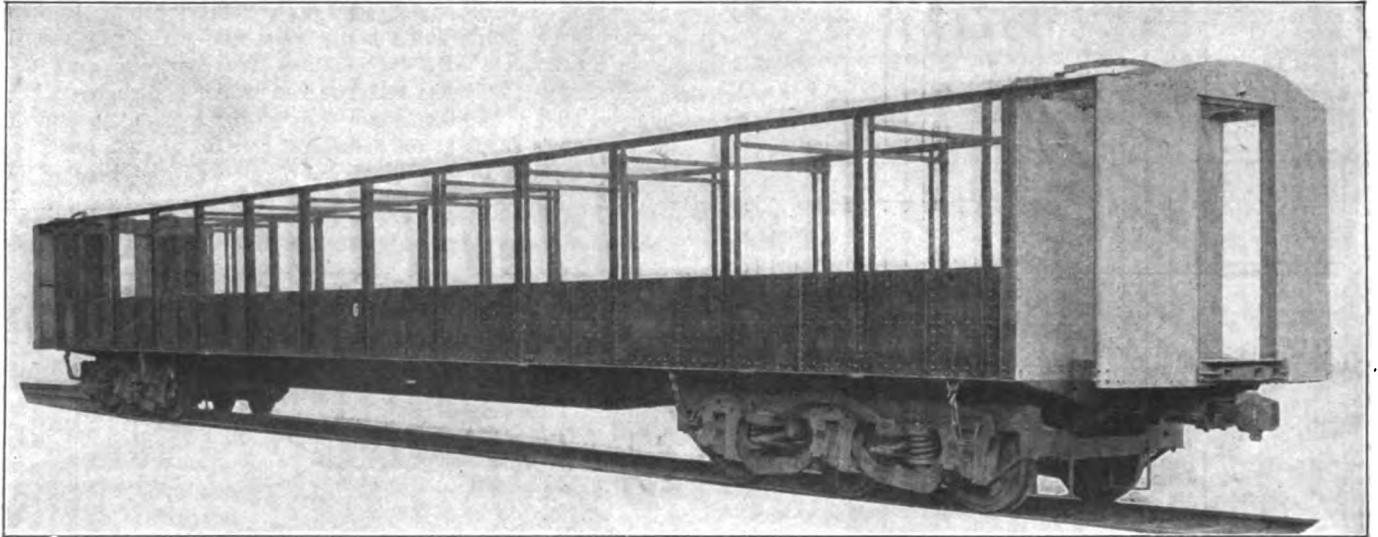

Grand Trunk Suburban Car During Construction, Showing the Arrangement of the Steel Members

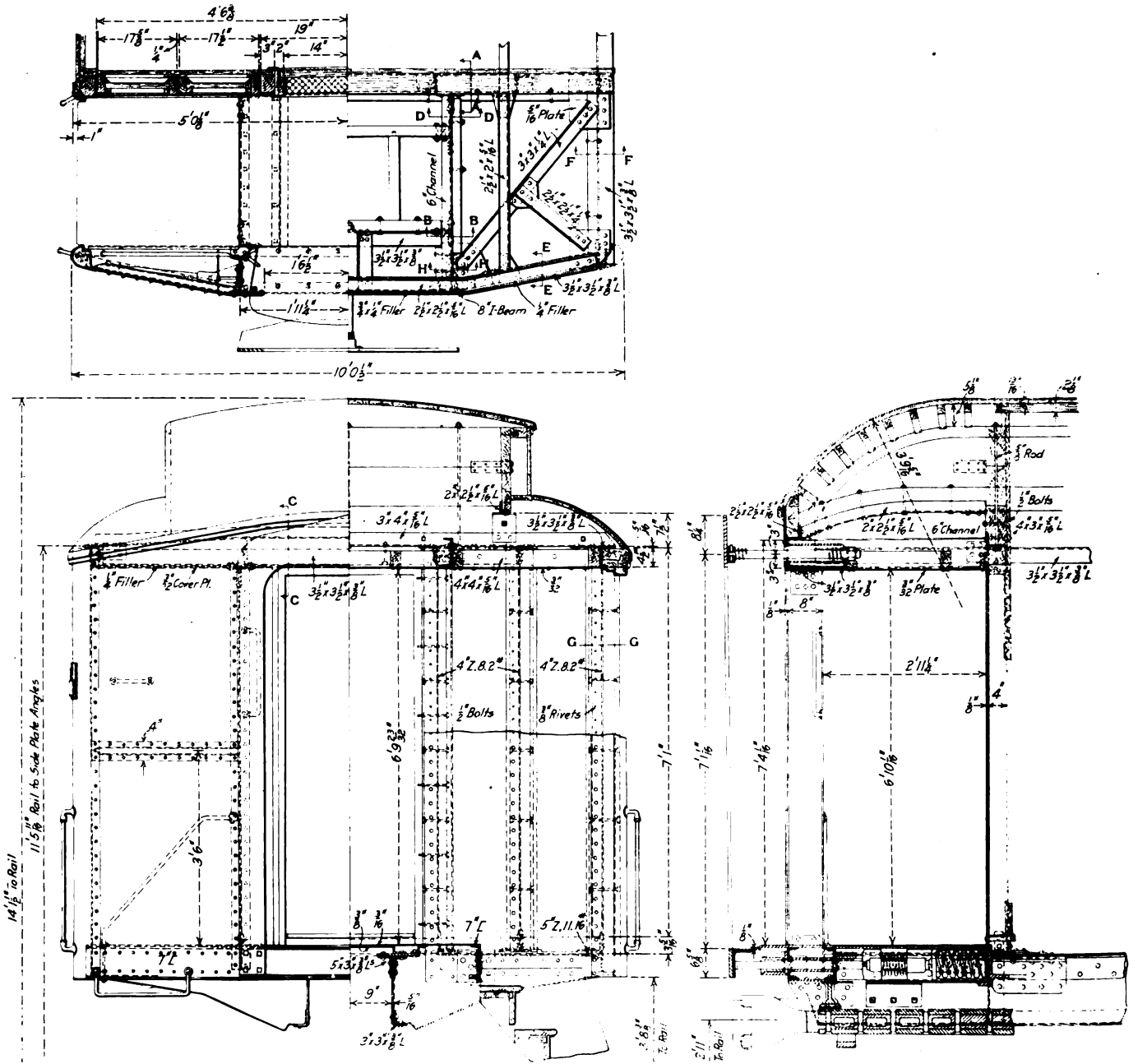

End Arrangement of the Grand Trunk Suburban Cars; the Detail Sectional Views Are Given in a Separate Drawing.

in. web plate and 3 in. by 3 in. by 3/8 in. bottom angles. The depth of the center sill at the center of the car is 26 in., and at the bolster 16 in. The body bolster is built up of eight 3/4 in.

in. pressed steel diaphragms placed back to back, with 10 in. by 3/8 in. top cover plate and 7 in. by 3/8 in. bottom cover plate, both extending the full width of the car.

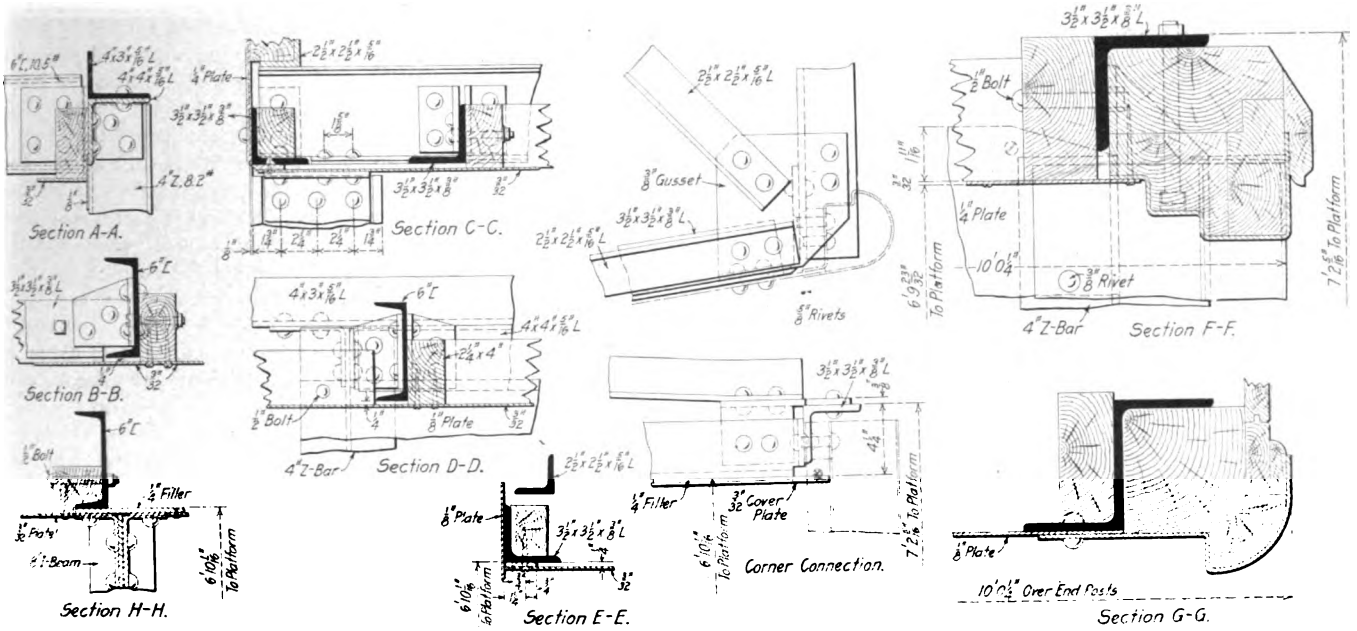

Details of the End Framing; the Section Letters refer to the Drawing of the End Arrangement

pressings as side members, one cast steel center member of heavy construction designed to take the locking device, a top cover plate 5 ft. 6 in. by 5/16 in. extending the full width of the

BODY AND END CONSTRUCTION

The side girder consists of a 1 3/8 in. by 4 in. by 7/16 in. drop- per bar, 1/8 in. by 35 in. web plate, 2 in. by 2 1/2 in. by 3/16 in. intermediate angle and 5 in. by 11.6 lb. Z-bar side sill. The side posts are 3 in. by 2 in. by 1/4 in. angles, and the side plate is a

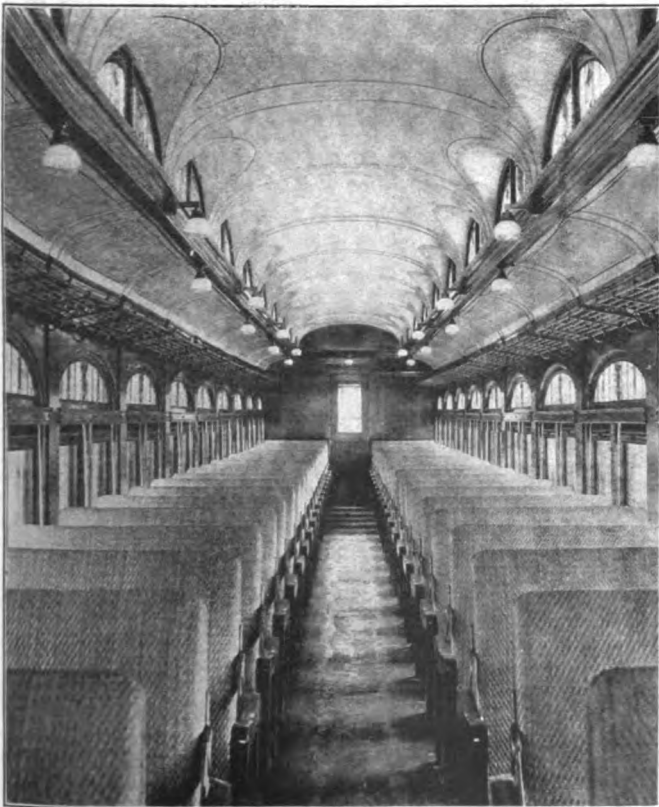

Interior of the Grand Trunk Suburban Car

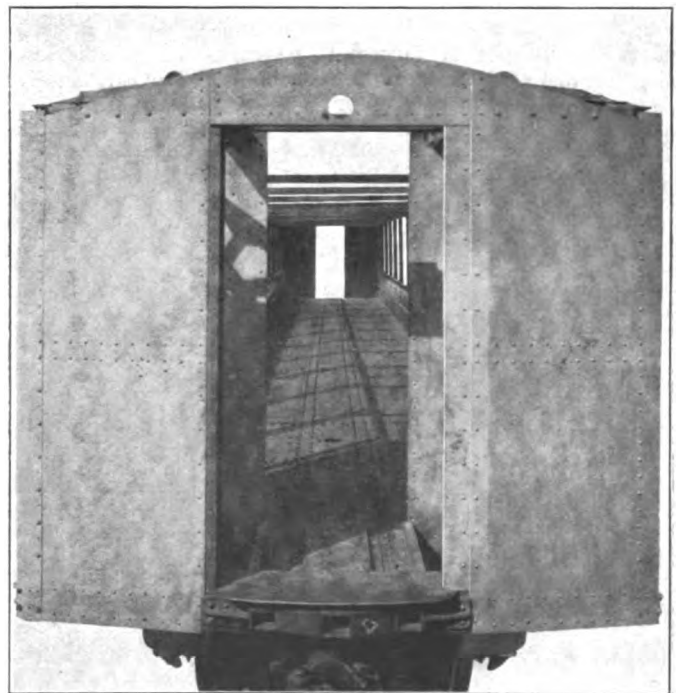

An End View of the Steel Work

car and two 7 in. by 3/8 in. reinforcing plates extending from side sill to side sill. There are two crossbearers placed 14 ft. 3 in. on either side of the center of the car and built up of 3/4 in.

3/2 in. by 3 1/2 in. by 3/8 in. angle. The steel construction of the body is reinforced with wood posts and horizontal and vertical wood blocking. The interior and exterior finish is of wood. Wrought iron carlines, 2 in. by 5/8 in., are riveted to the side plate, completing the steel superstructure, and here again

the wood reinforcing is employed. Canvas duck is used for the final roof covering and the headlining is $3/16$ in. Agasote. Agasote is also used below the belt rail. No special insulation was necessary in this construction except below the belt rail, where $3/4$ in. Salamander is applied outside the $1/8$ in. steel plate. Special care was taken, however, for insulation under the floor, two air spaces, two layers of $3/4$ in. Salamander and one layer of Neponset paper between the upper and lower course of the floor being used.

The end posts are 4 in., 8.2 lb. Z-bars with wood reinforcing, and the end plate is a 4 in. by 3 in. by $5/16$ in. angle. The vestibule posts are 8 in., 18 lb. I-beams connected at the bottom direct to the platform end sill, which is built up of 7 in. channels, while at the top these I-beams are connected to the body of the car by 6 in. channels running parallel with the center line of the car and by 3 in. by 3 in. by $1/4$ in. angle diagonal braces from the ends of the I-beams to the corners of the car body; these braces are in turn braced to the vestibule corners by $2\frac{1}{2}$ in. by $2\frac{1}{2}$ in. by $1/4$ in. angles. The vestibule end plate is a $3\frac{1}{2}$ in. by $3\frac{3}{8}$ in. angle and 2 in. by $2\frac{1}{2}$ in. by $5/16$ in. angles brace this plate to the end of the car body between the I-beam and the outside of the car. The vestibule is sheathed with $1/8$ in. steel plate.

The interior finish is mahogany and rattan seats are used, the seating capacity of the car being 96. The Stone Company's axle system of electric lighting is used, the generators being arranged to cut in at about six miles an hour, and the cars are heated by the Chicago Car Heating Company's vapor system of steam heat. They were built by the Canadian Car & Foundry Company, Montreal, Quebec.

BRITISH ALL-STEEL KITCHEN CARS

The first all-steel passenger train cars to be used in Great Britain were recently placed in service on the express trains of the East Coast Joint Stock running between London, Newcastle, Edinburgh and Aberdeen. There are three of these cars, which were built at the York works of the North Eastern Railway, under the direction of Vincent L. Raven, chief mechanical engineer of that road. They are self-contained kitchen cars, and are devoted entirely to the supply of food, wines, etc., thus acting as

to build these cars of steel. All the other vehicles in these trains are lighted by electricity.

The underframe is built entirely of British standard steel sections, and is of the trussed type. The side sills or solebars are in one length, the section employed being 9 in. by $3\frac{1}{2}$ in. by $1/2$ -in. bulb angle, trussed with a $1\frac{1}{2}$ in. diameter rod carried 14 in. below the side sill. This member also carries a pressed plate section which supports the body posts, and also forms the lower attachment for the body panels, to which they are riveted. The center sills, or main longitudinals, are in one length from bolster to bolster, and the section is 9 in. by 3 in. by $3/8$ -in. channel. The end sills, or headstocks, have been made specially deep, in order to bring the body lines uniform with standard East Coast Joint Stock wooden cars, and consist of 15 in. by 4 in. 42-lb. channels. The body bolsters are built up of 10 in. by $3\frac{1}{2}$ in. by $1/2$ -in. channels attached to the center sills by heavy knees and angle gussets. The end diagonal braces are 8 in. by $3\frac{1}{2}$ in. by $1/2$ in. angles, while the end longitudinal sills are also angles, 10 in. by $3\frac{1}{2}$ in. by $1/2$ in. section. For the truss rod needle beams, two angles, each 6 in. by $3\frac{1}{2}$ in. by $1/2$ in., are arranged back to back, the queen posts being sandwiched into them at 6 ft. 3 in. centers. The underframe members are all well connected by gusset plates, bent plate and angle knees, the rivets in the main connections being $3/4$ in. in diameter. To carry the floor plating, in addition to the underframe members, 10 T-bars, 3 in. by $2\frac{1}{2}$ in. by $1/4$ in., are arranged at 4 ft. centers, and the floor plating is riveted to these and to the main members of the underframe.

The body framing is constructed throughout of British standard rolled angles, channels and T sections, having a breaking strength of 28 to 32 tons per sq. in., with an elongation of not less than 20 per cent. The main posts and the door posts are 3 in. by $2\frac{1}{2}$ in. by $1/4$ in. angles, bent to the required contour, and secured to the side plates by turning over the flange and to the side sills by 6 in. by 6 in. knees. All intermediate posts and local stiffeners are $1\frac{1}{2}$ in. by $1\frac{1}{2}$ in. by $3/16$ in. angles. The side plates are 3 in. by 3 in. by $3/8$ in. angles, carried continuously to the end sweep angles or end plates, to which they are connected by means of gusset plates. The top light rail angles, which are above the windows, are $1\frac{1}{2}$ in. by $1\frac{1}{2}$ in. by $3/16$ in., riveted to the posts, while the bottom light, or belt rails, are $2\frac{1}{2}$ in. by 3 in. by $1/4$ in. angles arranged to butt and rivet to the posts, which are stiffened by

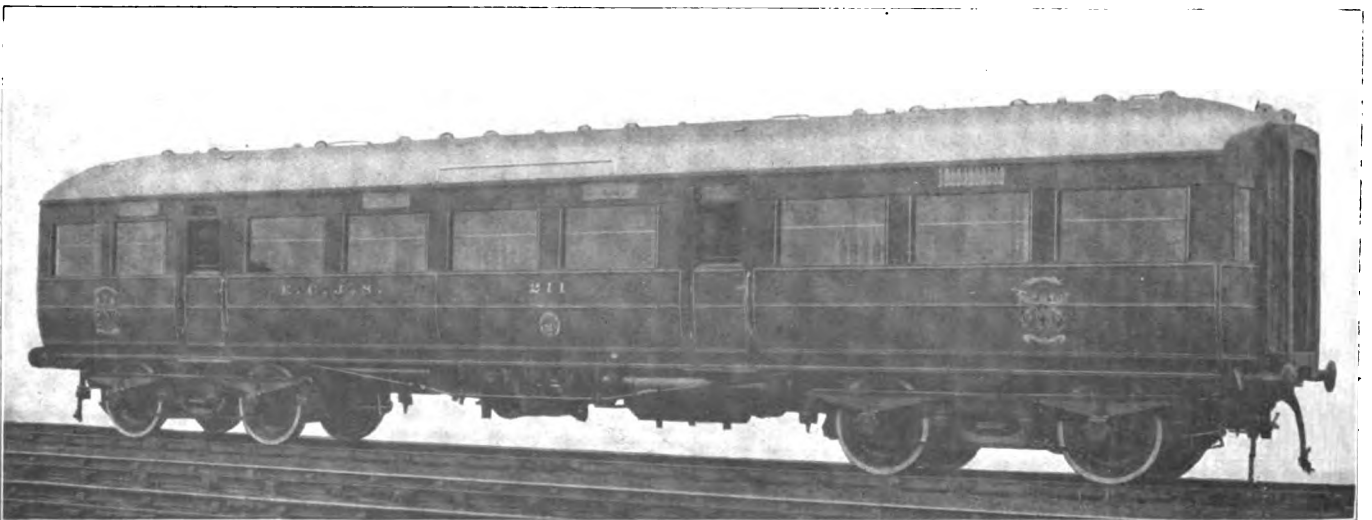

All-Steel Kitchen Car Used on the East Coast Route in England

tenders to the first and third-class dining cars, one car per train being arranged between these latter cars with a direct service to each simultaneously.

Owing to the difficulty of procuring sufficient current for an efficient electrical cooking installation, gas is used, and it was decided, with a view to reducing the liability of fire to a minimum,

bent plate knees between each two posts. The end framing has been arranged to provide ample resistance to impact. The corner posts and end posts are all 3 in. by 3 in. by $3/8$ in. angles, substantially secured to the underframe by forged knees; the corner posts being secured to the side plates by gusset plates $3/8$ in. thick. The top end arches, and the top and bottom framing rails, are

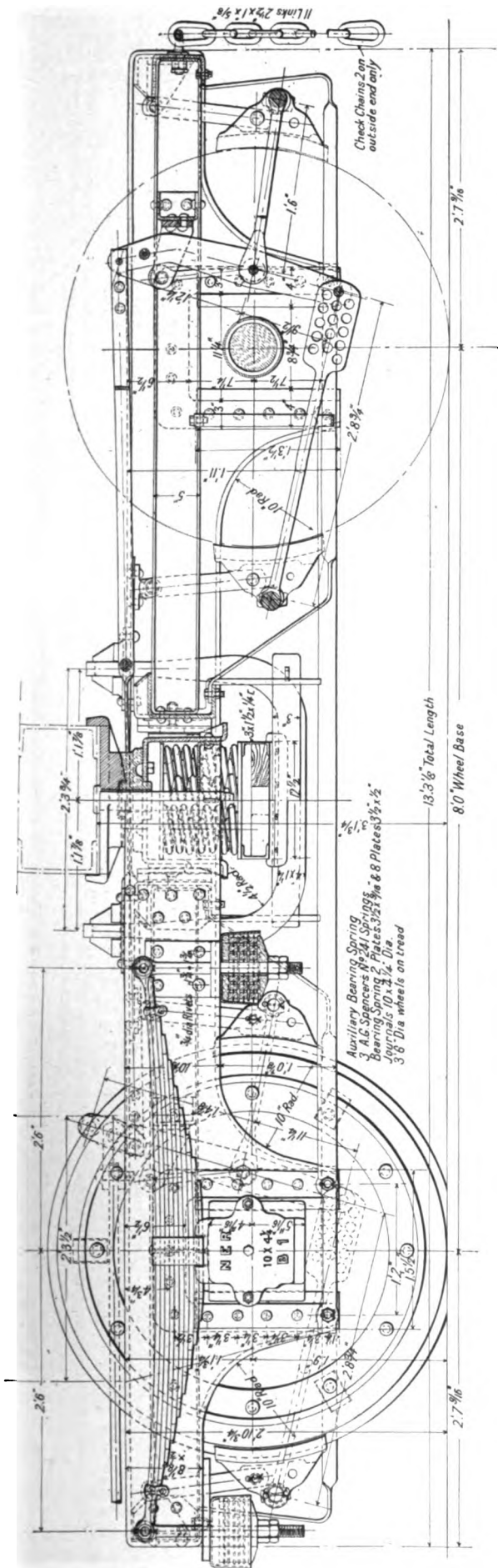

Four-Wheel Truck for the East Coast Route All-Steel Kitchen Car

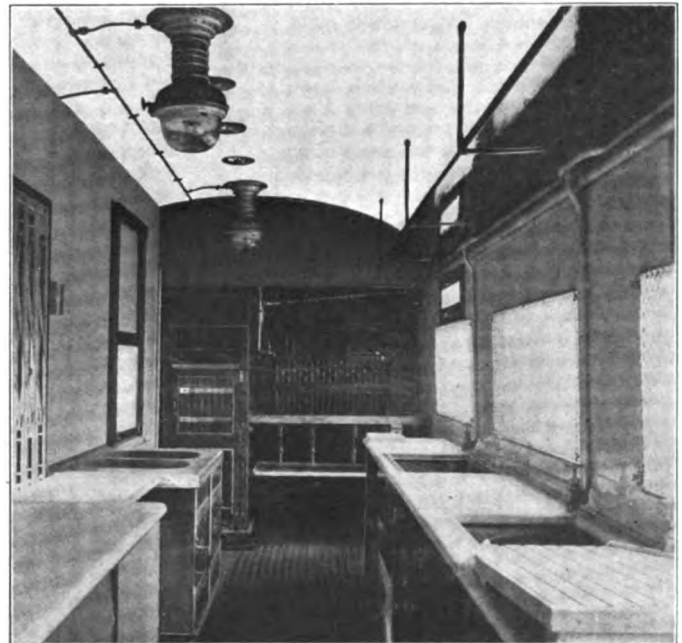

An Interior View of the Steel Kitchen Car

3 in. by 2½ in. by ¼ in. angles. The ends are adequately stiffened and braced to afford the Pullman vestibule gear the maximum of support.

The whole of the body outside paneling is of No. 16 gage charcoal finish, cold rolled, hydraulically flattened steel plate, arranged in various sizes to suit the framing. The general riveting is 5/16 in. diameter, all outside heads being countersunk in either panel or moulding. The mouldings are of rolled steel throughout and of various sections.

It was found that a thoroughly satisfactory arrangement was produced for holding the windows and inside paneling by filling in the side plates, belt rails and main posts with packing, which is screwed to the steel members. The main doors are lined outside and inside with steel plate of the same gage and manufacture as on the body.

The elliptical roof is constructed throughout of No. 16 gage steel plate curved to a template, and riveted to a series of 2 in. by 2 in. by ¼ in. T-bars, which are connected by gussets and rivets to the angle steel side plates. All rivets are 5/16 in. diameter, with countersunk heads on the outside. A cotton duck roofing canvas is laid over the steel and secured by No. 20 screws

to the side plates and end sweeps by a 2½ in. by 2 in. cornice. The roof ends are swept down 10 13/16 in., in a moderate curve. There are 13 torpedo air-extractors or ventilators arranged on the roof, those in the kitchen and pantries having large bell-mouthed openings, and no valves.

The floor consists of 5 lb. per sq. ft. steel plating laid from end to end, and is riveted to the underframe. It is covered with a plastic cement composition known as Decolite, ¾ in. thick, and waterproof, hygienic and impervious to insects. In the corridor, kitchen, pantries and passages, all square corners are avoided by sweeping the cement into a continuous curve. The corridor interior is fitted on the body side, from the sill to the roof casing, with No. 20 gage steel panel plate, secured to the steel framing packing by rolled steel mouldings. The corridor screen is also covered from top to bottom with the same material, so that the passageway from end to end is perfectly fireproof. The first-class pantry, located adjacent to the first-class dining car, is 9 ft. long, and 6 ft. 3¾ in. wide inside. It is entered by a collapsible gate, the doorway being 2 ft. 3 in. wide, and every convenience is provided for the storage of glass and chinaware, etc. At the end is a large drainboard for drying off the washed dishes,

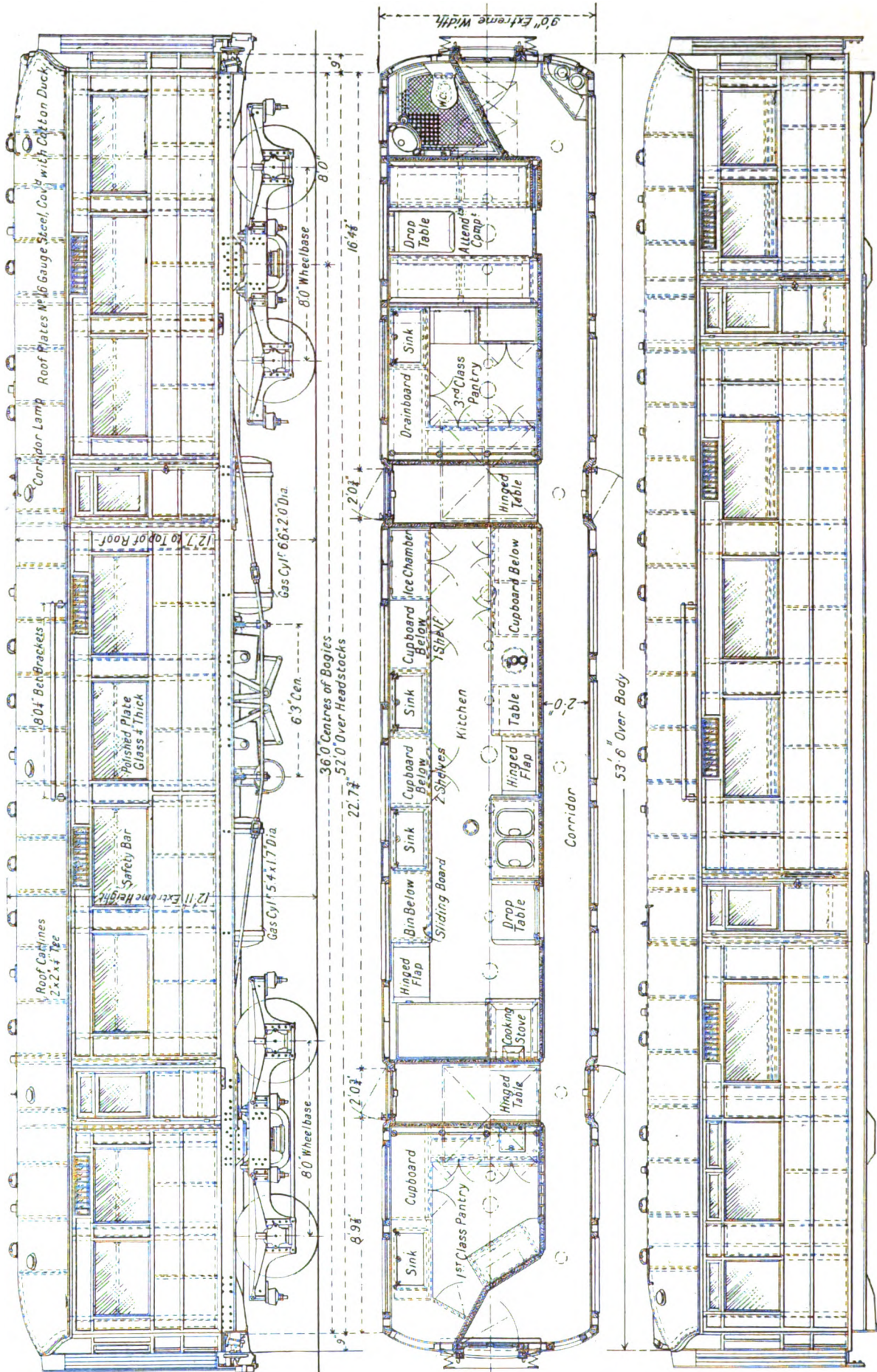

Side Elevations and Floor Plan of the East Coast Route All-Steel Kitchen Car

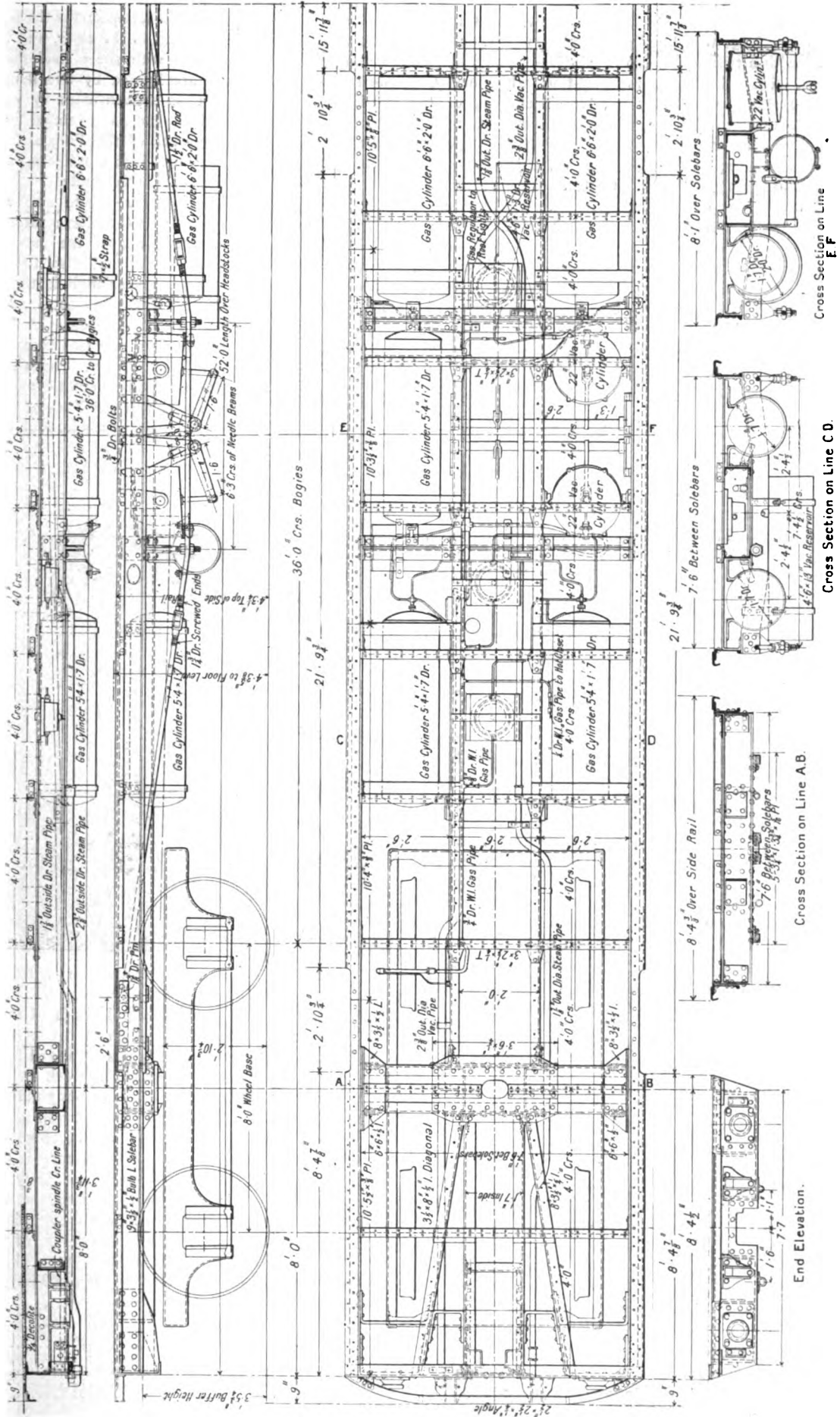

Underframe of the East Coast All-Steel Kitchen Car

with a storage cupboard below. Hot and cold water is supplied at all times to a large teak-lined sink, adjacent to which is another cupboard with a table top. Crockery racks are arranged above the head level on the transverse partition, while below, there are the plate racks, refrigerator and ice closet, wine cupboard, etc., an additional cupboard or sideboard being arranged for with a large complement of drawers. An improved pure water filter with hand pump is arranged over the sideboard.

An incandescent gas lamp of 50 c. p. is placed at the center of the pantry, and flanked by two torpedo ventilators. The ventilation is further assisted by a louvre ventilator, which consists of a series of vertical vanes so arranged that air may be induced or extracted at the will of the operator. A large water tank is placed adjacent to the pantry in the ceiling. The two transverse passages are 2 ft. 6 in. wide, and are necessary for ingress and egress, in addition to which all stores taken on the car come through these doors, and empties may be discharged and new supplies taken on simultaneously. A drop table is provided in both passages. These passage walls are lined throughout with steel plate and steel mouldings.

The kitchen is 22 ft. long by 6 ft. 7 $\frac{3}{4}$ in. wide, inside dimensions. At one end is located the range, occupying the full available width, the partition, roof and corridor screen around it being covered with asbestos and No. 16 W.G. steel plate. The range is raised clear of the floor. At the body side are installed two sinks with hot and cold water supply and a hinged flat table, while the table on the right-hand side serves the chef as a carving table, below which is fitted the cold storage, and the cupboard, which is ventilated, is used for the storage of fresh meat, fish, fruit, etc.

All the serving of meals is done on the corridor side of the kitchen, and the partition at this side is provided with an upward sliding door 2 ft. 2 in. wide, while a drop table is arranged below the hatchway as a serving table. The hot plate and closet are fitted with twelve burners.

The main entrance to the kitchen is off the corridor through a collapsible gate, with an opening 2 ft. 3 in. wide, a folding table filling up the gateway when the gate is closed. To provide for hot water at any time a patent hot-water geyser, gas heated, is installed, the boiler and gas rings being located below the table. The water supply to the boiler is taken from the overhead tanks, and is automatic. Two additional cupboards, the top of which serves as a sideboard if required, complete the kitchen. The ventilation, and the endeavor to avoid the sweating so common to kitchen cars, has been carefully planned, louvre ventilators being arranged over two out of the three windows on the body side, while six torpedo ventilators, with large brass bell-mouths, take out the impure air. The three side windows have double glass, and are protected from damage on the inside by galvanized wire frames. The floor is covered with steel mats, which can be taken up and thoroughly cleaned, in addition to which is arranged a large sump for the removal of all waste. Galvanized refuse bins of large capacity are located below the sinks. The entire kitchen sides and partitions are covered with white enameled iron plates.

Three pedestal gas lamps, each of 50 c. p. are applied, and arrangements are provided in the kitchen for cutting off the gas supply from the receivers on the underframe.

Adjacent to the kitchen is a second passage, with outwardly opening doors, identical with that already described, next to which is the third-class pantry. This is 6 ft. 5 in. long and 6 ft. 3 $\frac{7}{8}$ in. inside width, and is fitted with sink, drying board, bins for mineral waters, plate and crockery racks, pure water filter, hot and cold water, etc. Entrance is by means of a folding gate opening off the corridor. Over the single window is arranged a louvre ventilator, and two roof air extractors are also applied.

The attendant's compartment is 5 ft. 11 $\frac{1}{2}$ in. long, with two transverse seats, below which are lockers for uniforms. One incandescent gas lamp of 50 c. p. and pilot light is employed, flanked by two torpedo ventilators. A large lavatory adjoins the

attendant's compartment, and is set apart for the use of the staff.

The corridors, which are 2 ft. in the clear, and 1 ft. 9 $\frac{1}{2}$ in. at the door pillars, are covered with sheet steel throughout, varnished teak color. They are lighted by five lamps, fitted with pilot lights; each is of 50 c. p., and ventilated by four louvre ventilators. At the third-class end is a soiled linen cupboard.

The vestibule connections are of the Pullman type, and have canvas and rubber diaphragms. Two wind screens of the spring roller type are also fitted to each vestibule.

The supply of gas for the kitchen, and also for lighting, is carried in five storage cylinders, which have automatic valves to cut off the cylinders in the event of the pipes being broken through accident. The cylinders, and also the regulators, of which there are three, are housed as high in the frame as possible. The gas supply to the stove, hot-plate and lamps is controlled within the kitchen. The brakework is of the vacuum type with two 22-in. vacuum cylinders, and two reservoirs each 4 ft. 6 in. long by 1 ft. 3 in. in diameter. The leverage is so arranged as to produce 76 per cent of the tare weight brake shoe pressure.

East Coast Joint Stock cars use the Buckeye center coupling in conjunction with the Pullman vestibule, and this is fitted to

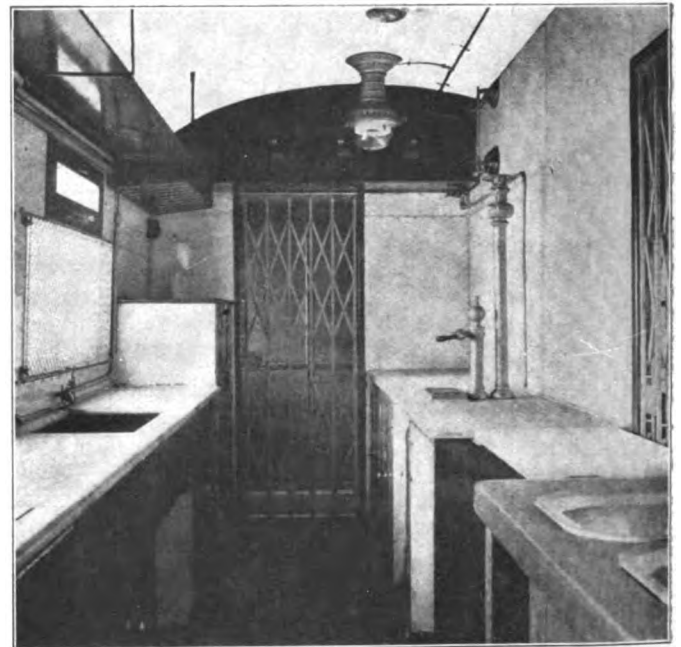

Another Interior View of the Steel Kitchen Car

these particular cars. The coupler head is of the latest pattern with vertical locks operated from the car side, and pulls directly on to a pair of steel springs arranged in parallel, which bear against steel castings sliding in cheek castings which are attached to the 10 in. by 3 $\frac{1}{2}$ in. angle longitudinal sills. If required, the coupler head may be hinged, and an ordinary screw coupling attached to a hook forged on the coupler shank for this purpose. The side buffers are of the telescopic pattern, and are not in use under ordinary circumstances, only being extended when running with vehicles with ordinary screw couplings.

The cars are mounted on two four-wheel trucks of 8 ft. wheelbase, placed 36 ft. between centers. They are of the Fox pressed steel pattern, and have side frames $\frac{1}{2}$ in. thick.

The weight of each car is 36 tons (of 2,240 lb.), which includes about 200 gallons of water in the roof tanks.

The principal dimensions are as follows:

Length over body vestibules.....	55 ft.
Length over body.....	53 ft. 6 in.
Length over end sills.....	52 ft.
Distance between truck centers.....	36 ft.
Truck wheelbase.....	8 ft.
Width outside body over mouldings.....	9 ft.
Width of corridor.....	2 ft.
Width over footboards.....	8 ft. 10 in.

SHOP PRACTICE

SPECIAL CHUCKS FOR AIR PUMP REPAIRS

BY W. W. ELFE

Machine Foreman, Central of Georgia, Macon, Ga.

A simple chuck for bushing valve chamber heads on 9½-in. air pumps is shown in Fig. 1. The chuck is made from a piece of ¾-in. by 7-in. wrought iron, the feet and inside face being machined so that they will be parallel. It is secured to the face plate of the lathe by means of bolts and proper alinement

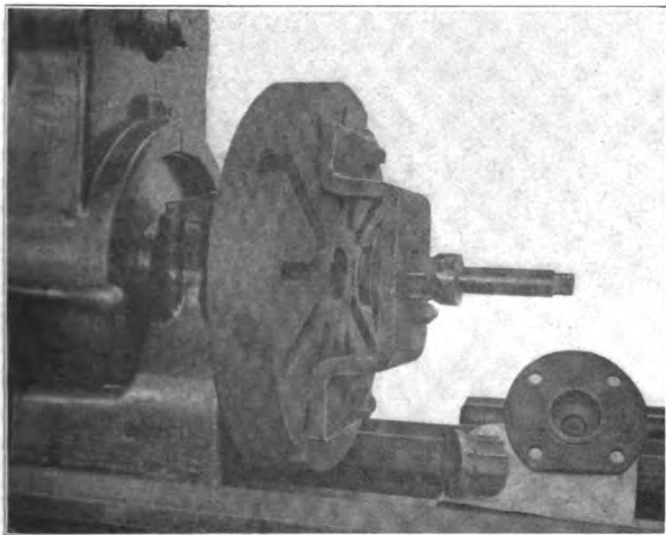

Fig. 1—Finishing Air Pump Valve Chamber Head for Bushing

facilitated by the use of dowel pins. A hole is bored through the center just large enough to fit the projection on the inside face of the head so that accurate chucking is accomplished without loss of time. Two shell reamers of high speed steel, both

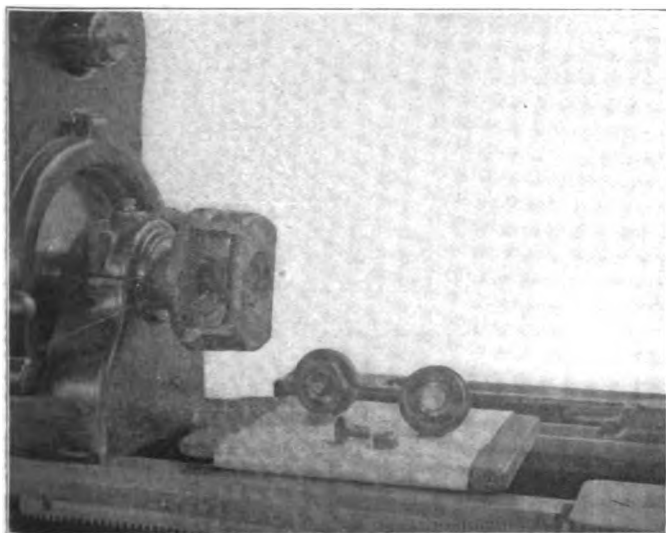

Fig. 2—Chuck for Repairing Worn Air Pump Check Valve Caps

fitting the same machine steel arbor, are used with this chuck. The larger one sizes the head for the bushing, which is applied with a press fit. After the bushing is applied the smaller reamer is used to finish it on the inside. The bushings are

1 11/16 in. in length and 2 7/16 in. outside diameter, the finished inside diameter being 2 1/8 in. When worn more than 1/32 in. they are removed and new bushings applied.

Fig. 2 shows a chuck used in reclaiming worn check valve caps from the air cylinders of 9½-in. air pumps. The chuck is bored to fit over a small face plate to which it is secured by means of two ½-in. cap screws. A hole is bored through the center and threaded so that the cap may be screwed in from either the front or back. The illustration shows the check screwed in from the back to have the valve stop faced off and to be drilled through the center for the dowel. The dowels are made on a turret lathe from 1 in. round bars, the shank being finished to ½ in. in diameter and threaded to receive a nut. After the cap has been bored it is removed from the chuck and replaced from the front, in which position the head is counter-sunk to receive a ½ in. nut. The body of the dowel is finished to a driving fit and after being driven into position is secured by means of the nut. The appearance of the repaired cap is clearly shown in the illustration.

PISTON ROD GLAND AND OILER

BY JAMES STEVENSON

Gang Foreman, Pennsylvania Railroad, Olean, N. Y.

The combined piston rod gland and oil cup shown in detail in the drawing is designed to replace the usual method of oiling

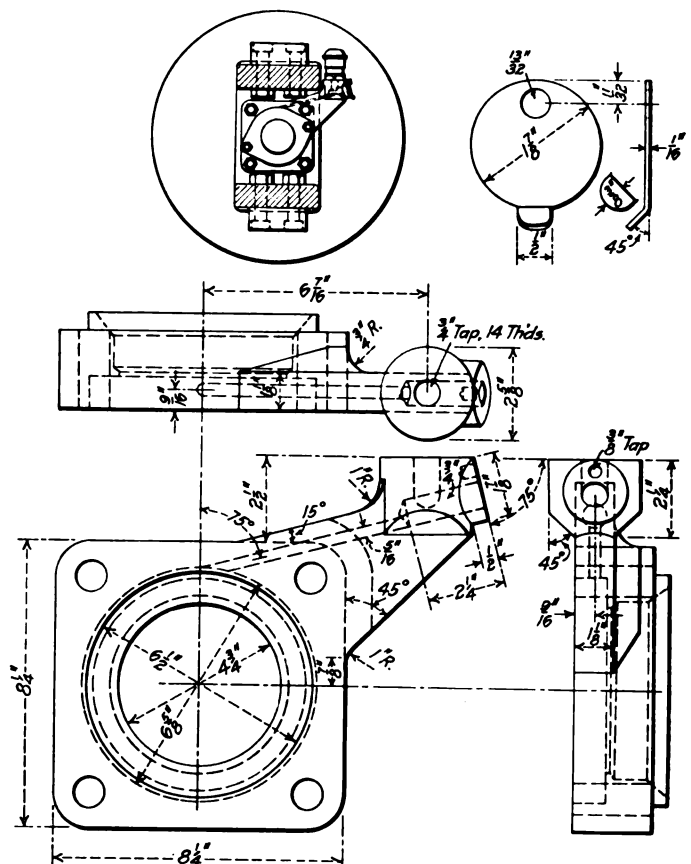

Piston Gland with Direct Attachment for Oil Cup

the piston rod packing through a pipe from an oil cup on the top guide. It is simple in design and includes a sight feed as

well as a means of access to the oil passage for cleaning without removing the oil cup.

An arm extending out to clear the side of the guide bar is cast on the upper outside corner of the gland. A 5/16 in. diagonal passage is drilled through the arm to the inside of the gland and the outer end of the passage is counterbored to a diameter of 3/4 in. Into this enlarged passage is drilled and tapped a 3/4 in. vertical opening to receive the oil cup, and the end of the diagonal passage is closed with a swinging cover secured by means of a 3/8 in. machine screw. By opening this cover it may be readily ascertained whether or not the oil cup is feeding properly, and in case new packing has been applied more oil may be added without disturbing the adjustment of the oil cup. By inserting a wire at this point the oil passage may be readily cleaned without removing the oil cup. This device was developed by the writer, and a patent has been applied for.

MOTOR DRIVE FOR A BRADLEY HELVE HAMMER

BY W. E. JOHNSTON

Chief Draftsman, Western Pacific, Sacramento, Cal.

When making the tool layout for the blacksmith shop of the Western Pacific, at Sacramento, a 200-lb. Bradley helve hammer was desired in a location near the center of the shop where the usual overhead drive would have been difficult to install on account of the height of the roof trusses. A framework resting on the floor for the support of the countershaft would have been unsightly, besides obstructing the space around the hammer.

To meet these conditions, the special drive shown in detail by the drawing was installed and has proved entirely satisfac-

by the treadle. Pressing down the latter raises the idler, tightening the belt and increasing its arc of contact on the motor pulley. The pulley is of cast iron and soon acquires a high polish, so that it runs against the slack belt practically without

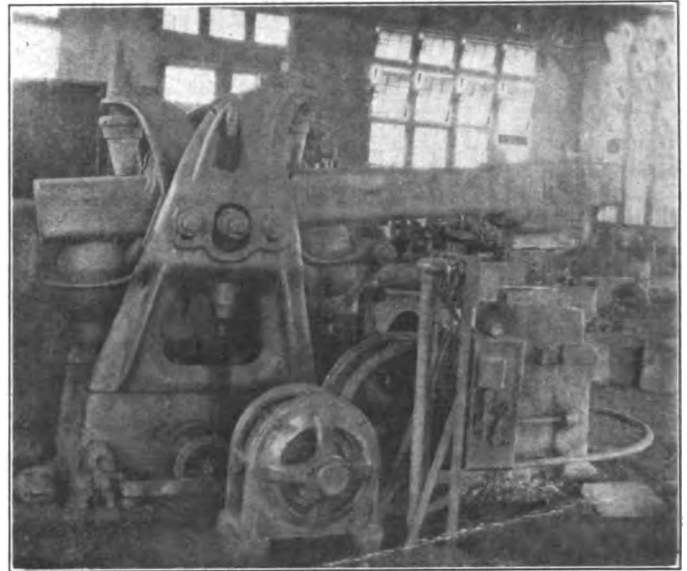

Location of Driving Motor for Helve Hammer

friction, but "takes hold" and starts the hammer promptly as soon as the treadle is depressed.

This drive has been in continuous service for over a year

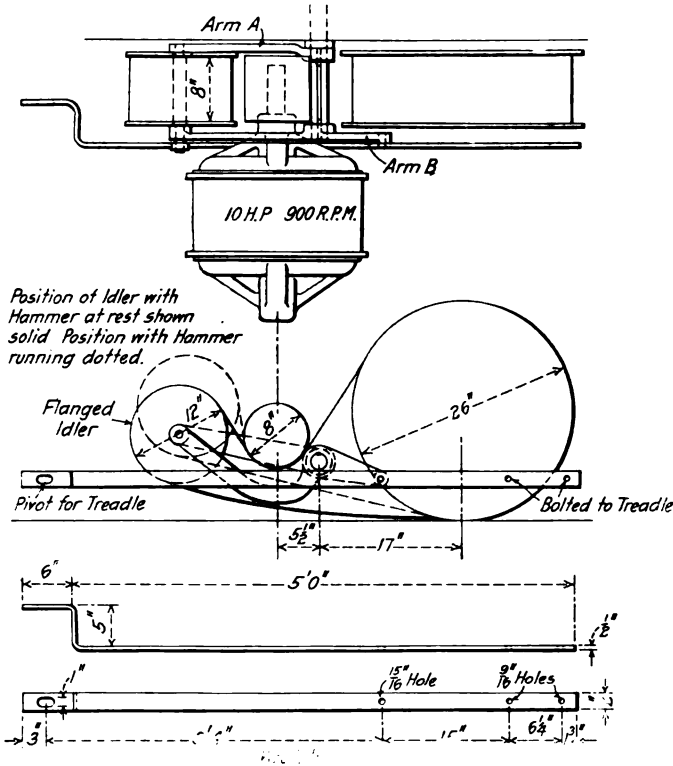

Method of Operation and Details of Motor Drive for Helve Hammer

tory. As shown in the photograph an induction motor is placed at the side of the hammer where it offers but little obstruction to the free use of the floor space around the machine. The motor runs continuously during the working hours. The hammer is operated by the treadle in the usual way. An idler pulley is secured between the ends of a double lever operated

and a half with no attention other than the occasional tightening of the belt as would be required with any belt drive.

EFFECTS OF IMPURE WATER ON TURBINE BLADES.—Impure water, even though treated, is sometimes the cause of a fine coating of lime forming on turbine blades.—*The Engineer.*

AN INSPIRING ADDRESS TO APPRENTICES*

"It Takes Great Courage to Perform a Perfect Task on a Thing That May Never Be Seen"

BY GEORGE M. BASFORD

Every man living, with real blood in his veins, desires to do something big, something noteworthy, something brave, something courageous. To have one's name associated in the public mind with some great heroic act, or some important work, gives a thrill of pleasure. To be the one to step forward from the crowd and show the way out of a difficult emergency, to be a leader, to wield power, to hold a place of prominence is the ambition of every real man. It is a natural and proper ambition. Thousands, many thousands of young men in the terrible fights of the European war are ready and eager to show their courage. They are impatiently waiting for calls for volunteers for difficult and dangerous service. They wish to be useful, they desire to make names for themselves and they know that the whole world is looking on, equally eager to admire and reward heroism with public approval. The dramatic features of a submarine torpedo attack, of the rescue of human life at a fire or in a runaway on a crowded street have an important influence on the men who make the rescues. It necessarily must be far easier to enter a burning building to save lives than to stagger against a winter storm on a desolate beach and struggle against a frozen gale to give warning of a shipwreck.

Who are the greatest heroes of the fight to the horrible finish of two battleships? They are the firemen, down in the bowels of the ship where the temperature is 150 deg., hot enough to drive men to madness. They tend their fires when the armor is pierced, when the electric plant is out of business, so long as the main engines are working. They then work in the dark, except for the light of their furnaces. They do not know the inspiration that comes from seeing the effect of their own work. They usually go down with the ship, but if victorious, victory is due to them as much as to those who wear uniforms and who inspire the poets.

It is difficult to be courageous and to do an arduous duty when no one is there to see, to praise or to know. If life could be concentrated so that we could nerve ourselves to individual, powerful efforts it would be easier to succeed, easier to win a high place and to keep it. Life, however, is not like that and success cannot come in that way.

You see the highest officers of this railroad passing through the shop where you are working. You cannot help admiring the men. You often think how fine it would be if you could drop your tools, wash up, dress up and be like them. They appeal to you because they are prominent, they are successful and they seem to you to be very powerful. They are big men, they are doing big things in a big way and you are ambitious to be like them. They are heroes in your eyes, as they are in mine. They are human, however.

How do these officers get to these high positions? Do they accomplish it by a few spectacular performances with the world watching and waiting to give its approval and its reward? They do not. These men are trusted with their great responsibilities, they have gained their high positions, because they have done something far different from that. These officers have worked like the surfman patrolling the beach. They have worked faithfully, in comparative obscurity, for many years. They have done the most courageous thing any man is called upon to do. Greatest courage is required, not for spectacular things, but for plain, simple, everyday work, in quiet obscurity. It takes great courage to

perform a perfect task on a thing that may never be seen and where imperfect workmanship cannot be traced and laid at your door. It requires more courage to do a good and thorough job for someone else, a perfect job and do it every day, whether you think anybody will see it or not, than to climb to a burning roof to rescue a human life. Because these men are heroes of this everyday kind they have been elevated to their fine positions.

You look at them as they pass through the shop and you wish to be like them. If you do as they have done you may perhaps be like them. You see the officials of the road as grown men in so-called middle life. Perhaps it does not occur to you that they ever were boys. Picture them as boys and young men of your own age. Life looked to them as it now looks to you. They, however, were different in some way from their comrades. At your ages they were probably but very little different and the difference was perhaps in attitude, in loyalty, in the courage that we have been considering. They certainly were good workmen and they were good subordinates, or they would never have been preferred and promoted. They were earnest. They were loyal. They did not do and, therefore, did not conceal bad work. They were doing something every minute. They selected friends in the shop that were worth while. They chose to admire good, strong, efficient men and they did not listen to the noisy fellow who told them that the bosses would think no more of them for extra effort or steadfast loyalty. They were, however, human.

Their successors are in this gathering tonight—who are they? You may all have ambition which will bring you no disappointment. You may not all be superintendents of motive power, but you may all be something else that is equally honorable and equally important. You may all be competent, honest, efficient workmen, doing good work every day. This will bring you satisfaction and happiness, for you will feel that these officers depend upon you and that they cannot hold their positions without you.

It does not matter how high you climb, but it does matter how far you climb. A friend recently told the graduating class of Harvard University that it means more to climb Mount San Bernardino than to climb Pike's Peak. The former begins at a point 300 ft. below the level of the sea and rises 11,000 ft. The latter begins at a point 7,000 ft. above the level of the sea and rises 14,000 ft. above that level, a real climb of 11,000 ft. in one case and 7,000 ft. in the other. It's where you start and where you finish that counts. These good friends and this good railroad are supplying the equipment for your climb. How far will you go? That's up to you.

These officers reached their high positions by climbing. When they started they prepared for the first step. They then prepared for the next one. They were always ready for the next job and they impressed this fact upon all who were around them. They were not to be kept down.

You are preparing for your first step in promotion. Have a care as to the preparation. Make known by your work that you are ready for the next step and patiently wait for it, making the preparation more secure as you wait. Somebody here this evening will be the first to be sought for and promoted. Are you prepared? Is it to be you?

As these officers go through the shop you see them. Do they see you? They certainly do. They are keen observers. They see you and what is more they see your work. Knowl-

*From an address entitled "Heroes," delivered before a meeting of the Chicago & North Western apprentices at Chicago on February 15, 1915.

edge of that also comes to them in their records of cost and of engine failures. Be assured the officers know every good workman. They know every hero in their ranks. They know better than you do what it means to be a good, faithful, efficient workman. They know better than you do that this is the foundation for the only success that is worth while.

When he passes you in the shop can you hold your head high, look the superintendent of motive power squarely in the eye, as a good American workman, feeling that you are absolutely necessary to him to aid him in dealing with his many and varied responsibilities? He may find you fitting up a driving brass, driving a rivet, beading a flue or putting in cotter pins. Let him find the work perfect and done at proper cost of time and material. He will know that that job will not worry him later as the cause of an engine failure.

That little cotter pin may bring in the train. Its absence may cause the wreck that costs the life of your father, your brother, your mother. But if the officer does not see your work, you yourself see it and when you look into the glass you wish to see a man and not a moral coward. Think how that passenger engine you worked on last week depends upon you, upon your heroism to resist the advice of one of your cowardly colleagues, who may say: "Let it go. It's good enough. No one will thank you for more than a passable job." If no one sees it, your reward will come in being able to walk out of the shop at quitting time, holding your head up, knowing that you are a man and that you have done a real man's work.

The Chicago & North Western has made you, has trusted you and honored you with this great opportunity. It holds out to you, as few railroads do, opportunities for preferment and advancement. This organization is led by men who grew up from the ranks, from positions such as you now occupy. The head of this motive power department has spent all his years of service on this road. Today Mr. Quayle stands with the greatest leaders of his calling. So does Mr. Bentley. They give you a better opportunity than they themselves ever had and beckon you on to the greatest advancement of which you are capable. They have established an ideal for you to strive toward. Their superior officers support them and offer you the best opportunities offered to any young men in railroad service today.

The future is up to you. Will you be traitors? Will you be heroes? Choose. Choose to be heroes in the heroism of simple honesty in the work that shows and in that which lies concealed, that you may look back in years that are to come, proud that you have done an important part in making the Chicago & North Western a better railroad than it was when it took you in and gave you this place in a great organization of real men. Are you worthy? Are you worth while? If you are not satisfied with your own answer you have something to do. "To see what is right and not to do it is want of courage."

A railroad as a business organization is like an army fighting its way step by step up a long hill. Many fall as they advance. Somebody is taking their places. Will you take these places or will you loaf and straggle and let the honest, earnest ones pass you? Will you shirk or will you work? You may shirk into a narrow, selfish existence of little value to yourselves and to others. You may work into a condition of useful progress, as these officers have done, but to go as high as they have you must aim high and you must consider, as they do, that nothing is ever finished.

How can I start a lot of lively young men like you to thinking of the future so that you will make the necessary efforts to take the places that you ought to take? Let me give you the story of "Reddy" Johnson as I had it from a friend down East.

"Reddy" was a machine shop apprentice eighteen years old and had nearly finished his time. He looked forward to a fore-

manship more than to anything else in the world. The concern had a traveling salesman, Van, by name, who sold all the shop could make. He had graduated from the shop and made \$3,000 a year. He did about as he liked, was looked up to by everybody and what he said "went" with the old man. "Reddy" thought him a prince and wondered if he would ever reach so high a place. Whenever Van came to town he would come into the shop, talk with the foreman and look after his orders. He came in one day and wandered over to see "Reddy."

"Well, 'Reddy,'" he said, "when are you going to be foreman?" Then he sat down and drew "Reddy" out. "You can be foreman either of this place or some other, just as soon as you can boss men. You've got to start in and practice just as you did on the lathe and planer."

"How can I practice?" asked "Reddy," "I'm only a cub here and everybody bosses me and I've got to do as I'm told."

"Well, 'Reddy' Johnson, you can practice on one and that's Johnson."

"Me?"

"No, not you, but Johnson. Every man has two distinct personalities in the one body. One is energetic, ambitious, likes to do right and get along. That's you, 'Reddy.' The other is careless, shiftless, lazy and fond of a good time. That's Johnson. Now, 'Reddy,' what you've got to do is to learn to boss Johnson, your other self, and you'll find it a big job. When you can boss Johnson successfully and keep him up to the mark all the time and keep him good natured about it—then and not till then you'll have the skill and practice to boss more than one man."

The idea struck "Reddy" and he tried it. In the course of a week he liked the game. As "Reddy" the foreman he bossed Johnson the workman and jacked him up whenever necessary, and, according to "Reddy," Johnson was a bad one. Van went out on the road and "Reddy" went after Johnson. He made him study, checked him up in his work and had a poor opinion of him generally. One night he went to a show and before the curtain rose he heard two people talking in front of him. One had been away and said: "How's 'Reddy' Johnson doing?" "Fine," said the other, "he's assistant foreman at the shops now, in charge of erecting, with from three to ten men under him all the time."

"Reddy" heard no more of the play. "Was I foreman?" thought "Reddy." "How long have I been foreman? When the new wing was put up six months before I was put to work in it with some helpers and my wages raised. Yes, I had been foreman for six months and was so busy bossing Johnson I hadn't noticed it."

This is said to be a true story of the real start of a successful man. Think it over. Try it.

Let me leave this thought with you.

One stone at a time builds the world's greatest structures. One step at a time makes our journey. One day at a time makes our lives. Little improvements in small things faithfully continued make men great.

POLES FOR TRANSMISSION LINES.—The choice between steel and wood poles for transmission lines is mainly a question of first cost plus maintenance charges. In the industrial districts of England there are many reasons why wood poles cannot be run in a straight line, with the result that the spans usually do not exceed 85 yd. in length. For such spans it is cheaper in first cost to employ wood poles which require no after maintenance. Under exceptional conditions, such as in Cornwall, longer spans can be used and steel poles can then undoubtedly be employed with advantage. Steel poles should not be employed in smoke and fume-laden districts without the most careful investigation, because experience with them on tramway and railway systems has shown that their rate of deterioration is rapid, and the cost of maintenance in painting, etc., is high.—*The Engineer.*

TURRET HEAD FOR PLANING GUIDES, SHOES AND WEDGES

BY B. O. YEARWOOD

Machine Shop Foreman, Virginian Railway, Princeton, W. Va.

The planer turret head shown in the illustration was designed by the writer and applied to a Detrick & Harvey 42 in. by 20 ft. open-side planer for use in finishing guide bars, and both the inside and outside of shoes and wedges at one

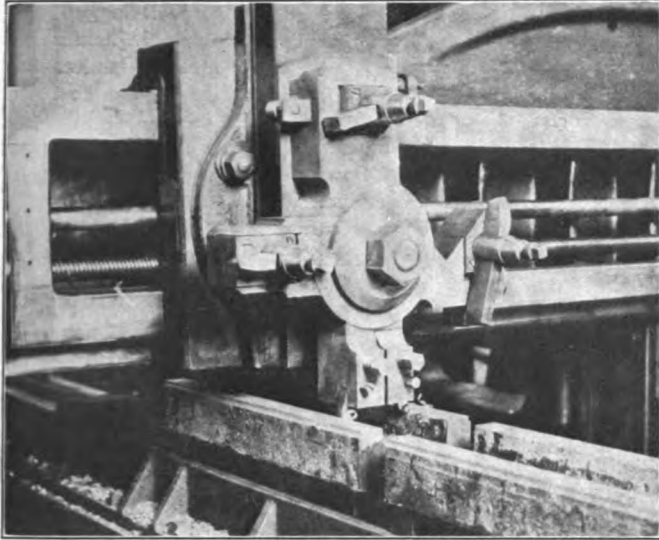

Turret Head Set for Finishing the Inside of Shoe Flanges

setting. The saddle on the crossrail is of the standard pattern and the only change required for the application of the turret head was the insertion of a central stud in the vertical slide, about which the turret head revolves. The turret has four arms, three of which are each provided with a single

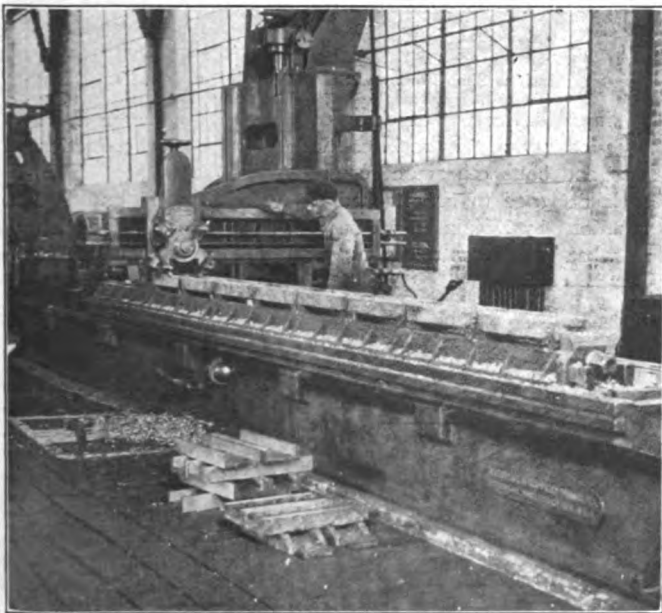

Finishing the Outside of Driving Box Shoe Flanges with Planer Turret Head

tool post taking tools of $\frac{3}{4}$ in. by $1\frac{1}{2}$ in. section. The fourth arm is provided with two tool holders in which are secured $\frac{3}{4}$ in. square tools for finishing the inside of shoe and wedge flanges. Both guide bars and shoes and wedges are clamped

in a special jig provided with a single tie rod, thus making it necessary to tighten but one nut in clamping the whole job. Locomotive guide bars are planed from the rough forging, the face and both sides being machined at one setting ready for finishing on the guide bar grinder. Shoes and wedges are completely finished at one setting ready to be placed on the engine and laid off. The illustrations show the construction of the turret head which provides for planing both sides of the work at one time. Both the inside and outside of shoes and wedges are finished in one operation and the single tool mounted in the straight arm is used for finishing the horizontal surfaces. Steel shoes and wedges are being finished in this manner for 9 to 11 cents each.

SUGGESTIONS FOR A PROPERLY KEPT ROUNDHOUSE*

BY W. U. APPLETON,

General Master Mechanic, Canadian Government Railways, Moncton, N. B.

The foreman who is under the impression that it is necessary to maintain a comparatively large staff for the special purpose of keeping the shed clean is under a misapprehension as the proportion of roundhouse expense directly chargeable to such work should be very light. One or two men assigned to general cleaning should be ample at our largest sheds and with the different gangs and individuals doing their part the sheds should always be in a presentable condition. With men assigned to do all the work the tendency is to cause the other classes to become careless and untidy, resulting in a dirty shed at all times. The wood wheeler should carry a broom and after unloading the wood and putting it on the locomotive should gather up all refuse and make proper disposition of it. He can also assist materially by keeping the wood pile in proper shape and using the small broken pieces. The same applies to the fire builder who should keep the floors of the cabs clean and free from coal, etc.

Proper receptacles should be located between the pits for dirty waste and the wipers should be careful to always gather up and put their waste into them while performing their work and when completed. This means very little effort and loss of time compared with the result to be accomplished. Suitable inexpensive receptacles may be easily made from worn out air reservoirs and smoke stacks.

The ashpitmen should keep the premises about the pits and their shanty in a neat condition and a suitable inexpensive rack should be provided for the tools and hose. They should insist on the valves of the water supply being kept in good condition to prevent waste of water which is generally expensive and sufficient of which might easily be wasted to be equivalent to \$1 or \$2 a day.

The tube cleaners should where possible take care of all soot and cinders removed from the tubes or front end. The boiler-maker helper or other employees could assist to a large extent when removing ashes and cinders from a front end by always putting them into the barrow or trolley that would ultimately be used to carry them away instead of throwing them on the floor. This would prevent a duplication of the work and a dirty shed.

Fitters using blocking, etc., should see to it that it is properly piled in the places assigned for it when the work requiring it has been completed and all tools should be kept together and returned to the tool room when not required.

Suitable scrap bins are important; separate bins for the different classes of scrap to the extent necessary to avoid extra handling should be provided and the bin for worn out brake shoes should be so arranged as far as possible to permit inspection of the shoes at all times. A bin for scrap material

*Extracts from an article in the Canadian Government Railway Employees' Magazine, January, 1915.

that there is possibility of working over is a good feature and all bins should be periodically inspected by chargehand and foreman to insure against good material being scrapped. All scrap should go to the bins as it accumulates; if a defective arch bar or spring hanger is replaced it is equally important to make prompt and proper disposition of the defective part as it is to replace it, as far as organization is concerned. All scrap brass and copper should be personally inspected by the chargehand who should decide regarding its disposal and a system of getting proper receipts for it should be in effect. Valve bodies are sometimes condemned owing to defective seats when they are fitted with removable seats and it is only necessary to renew the seats. A careful check should be kept on all valves, gages, regulators and air brake materials and requisitions for new stock should never be issued without first ascertaining what has become of the old.

CARE OF LYE TANKS

BY J. A. JESSON

The lye tank is an important feature of shop equipment for the repair of the various parts of the air brake apparatus and other locomotive appliances which has received comparatively little attention. The writer has experimented considerably with tanks of various shapes and with several methods of regulating the solution with results that were very interesting as well as beneficial.

The ideal location for a lye tank is inside the shop, where the temperature of the atmosphere is constant. When located in the open air the conditions are such that it is difficult to maintain a solution of uniform strength. It is im-

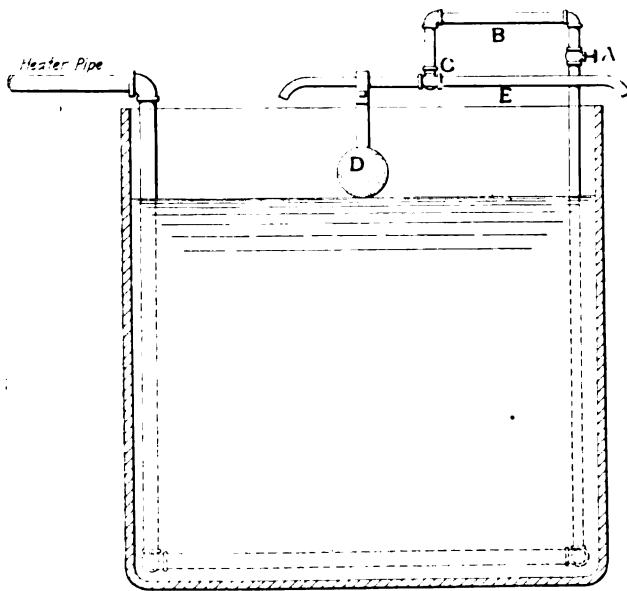

Automatic Regulating Device for Lye Tanks

possible to even approximate the amount of raw lye required, especially where the contents of the tank are being continually changed and where the tank cover is not a close fit. From tests made in the open air with a tank 2 ft. wide, 2 ft. deep and 8 ft. long, the solution in which was 18 in. deep, the evaporation at an atmospheric temperature of 80 deg. amounted to 6 gal. per hour, or at a rate which would result in an entire change of volume in 30 hours. At a temperature of 20 deg. the evaporation was 8 gal. per hour, or an entire change in 23 hours. To automatically maintain the depth of the solution at 18 in. under such varying conditions proved to be a difficult matter. The common practice of feeding

steam to the solution through a certain size orifice in the steam pipe proved to be wholly unreliable. A sensitively operated float valve gave very good results so long as the valve remained free from leaks, but scale from the steam pipe would lodge upon the valve seat, resulting in an increase of water supply and consequent danger of overflow. Several float arrangements were tried out, but finally the device shown in the drawing was adopted and the results have been most gratifying.

A 3/4 in. heating pipe is located around two sides and one end of the tank. To prevent excessive boiling of the solution around the down pipe to the heater it is well lagged with rope asbestos. The outlet pipe from the single heater coil leads to a 1/4 in. globe valve A which admits the condensation to a 1/2 in. pipe B. A loose connection is made at the tee C. A float D is connected between the tee and the inner end of the pipe E. As the solution evaporates this pipe will be pulled down and the condensation will flow into the tank. As the level of the solution is raised the pipe is also raised until the excess condensation flows out at the other end of the pipe B, which delivers outside of the tank. Sufficient heat to bring the solution to a gentle boil and an ounce of raw lye to each 18 gal. of evaporation seems to meet all requirements.

In cleaning air pumps waiting repairs, the pump is placed in the tank in an upright position, supported by iron bars which engage the upper flange of the center piece and rest on the rim of the tank. The usual steam and exhaust connections are made and the air cylinder inlet and discharge connections are provided with pipe fittings, the open ends of which are immersed in the tank. The solution can thus be taken in and forced out of the cylinder back to the tank without any loss and the connections can be readily changed for passing fresh water through the pump without its coming in contact with the contents of the tank. By this arrangement the interior and exterior of the cylinder are thoroughly cleaned in a remarkably short time. A loose partition is placed in the tank to prevent the disturbance of the solution in the other portions.

JIG FOR PLANING ECCENTRICS

BY H. L. LOUCKS

Machine Shop Foreman, Erie Railroad, Danmore, Pa.

A simple device for chucking eccentrics on a planer is shown in the engraving; it replaces the miscellaneous collection of blocks and bolts otherwise required for this purpose. The device is designed to be attached to the planer bed and is 3 ft. 4 5/8 in. long by 17 1/4 in. in width. The height of the sides is such that when the eccentric is in position it is firmly held from

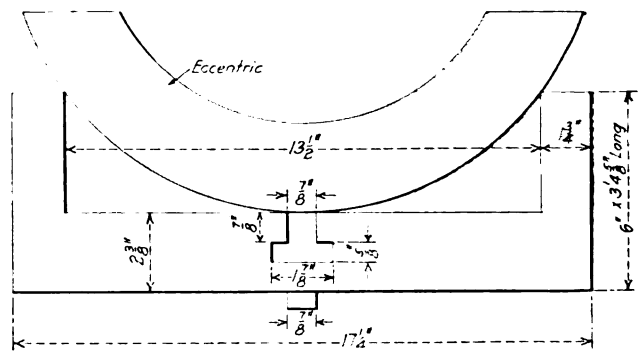

Jig with Eccentric in Place

rolling and may be secured by a single clamping bolt in the tee slot in the bottom of the jig. Several pieces may be finished at one time. Other material, such as shoes, wedges, gibs, crossheads, etc., may be planed in the same device, the sides providing a means of pinching and holding the piece in line.

MACHINE STEEL FOR SMALL TOOLS

BY OWEN D. KINSEY

Toolroom Foreman, Illinois Central, Burnside, Ill.

Soft steel as a material for manufacturing small tools is worthy of consideration, and it is surprising to learn how extensively it can be used as a substitute for the higher-priced materials. Steels used in tools in railroad service may be classified under three heads, namely: High-speed steel; first carbon steel and second carbon steel, the last two being commonly

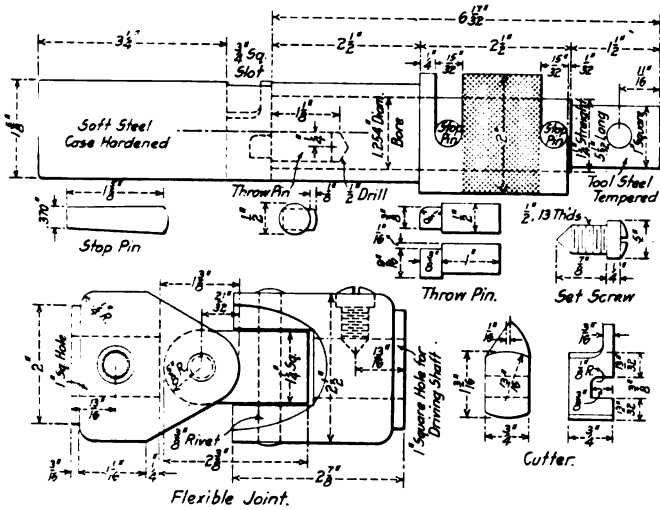

Fig. 1—Flue Cutter Made of Soft Steel Casehardened

known as tool steels. High-speed steel is, as its name implies, a steel that is suitable for cutting metal at high speeds. Its introduction revolutionized metal working and has brought about a marked advance in production. It is the most expensive of the three grades named, its value ranging between \$50 and \$60 per 100 lb. There is a great difference of opinion as to its

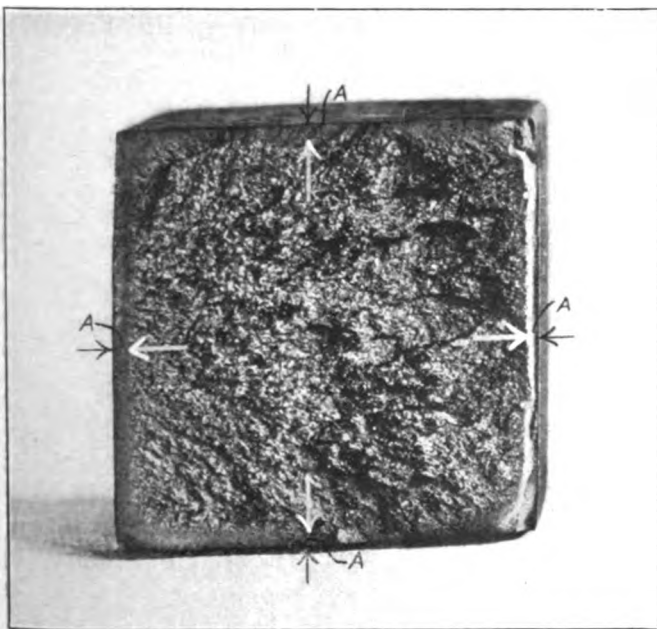

Fig. 2—Sample Bar Showing the Depth A of the Casehardening (Twice Actual Size)

economical use. Some maintain that tools made of this steel should be made in one piece, which obviously entails a great amount of expensive material. There are many instances where a solid tool is the more efficient and economical, and on the

other hand, there are just as many instances where a solid tool is pure extravagance. These points will be touched on later.

First-grade carbon steel is particularly suited for hand tools and for finishing purposes. It is especially suited for cutting tools, such as hand reamers, hand taps and dies, shear blades and other tools of a similar kind. The cost of this steel varies from \$15 to \$18 per 100 lb., and although inexpensive as compared with high speed steel, the cost of solid tools made from it, such as crosshead reamers, knuckle-joint reamers, washout-plug taps and other heavy tools, amounts to a surprisingly high figure. For instance, in a set of eight crosshead reamers the steel figured at 15 cents a pound would aggregate a material expense of \$67 alone, not considering the expense of handling the heavy bars, cutting off and getting the stock ready to start the work. By inserting carbon steel blades in soft or machine steel bodies the material cost totals only \$16, the labor being slightly in excess of labor costs of machining the solid material. Second-grade carbon steel, which is worth from \$10 to \$12 per 100 lb., is suitable for other than cutting tools, such as sectional expanders, roller and expander pins, forging dies, etc.

Soft steel ranges in price from \$1.55 to \$1.75 per 100 lb., and can be used extensively in manufacturing small tools where good case-hardening and heat-treating facilities are available. For cutting purposes it cannot be relied on nor is it recommended. However, for many other purposes it is a very valuable

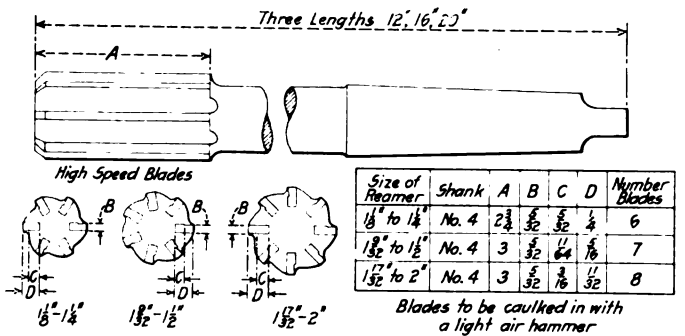

Fig. 3—Rose Reamers of Soft Steel with High Speed Steel Inserted Blades

material. One instance where it has positively proved superior to tool steel is in the manufacture of flue cutting tools. (See Fig. 1.) This particular tool, when made entirely of tool steel, was a source of much trouble, due to the breaking of the barrel which holds the tool steel cutter. We found that if the barrel was hardened it would snap off when under working strain. If it was used soft it would do the work better, but when the knife broke it would be cut in two by pieces of the knife wedging in between the inside of the flue and the barrel flue cutter. Soft steel, case-hardened and drawn to 450 deg., has overcome this trouble completely and makes a successful tool in every respect. It is, moreover, a much cheaper tool to produce.

For manufacturing flue roller bodies the soft steel has proved equally satisfactory; in fact, it is superior to tool steel, as it has an elastic body, and a hard and tough outer surface. Our practice is to case-harden to about 1/16 in. deep, cool slowly and reheat at 1,600 deg., quench in oil and draw to 450 deg. in an electric furnace. This produces a hard, tough, outer surface and an elastic body. Fig. 2 shows the texture of a piece of machine steel thus treated. Eight and one-half pounds of raw material is required for a complete flue roller for 2 in. flues. If made of second-grade tool steel at \$0.12 per pound, the material cost is \$1.02 each. If made from soft steel the same tool costs \$0.125 for material, which, manufactured in quantities of six dozen shows a saving of \$64.80 in material. Moreover, a marked gain is made in machining costs, which just about covers the expense of case-hardening and heat-treating.

The following is a list of tools which we manufacture, util-

izing soft steel extensively: Drill chucks, drill sleeves, drill repair sleeves, drill extension sockets, flue cutter holders, flue roller bodies, steel nuts, equalizer jacks, square sockets. (Morse taper shanks for machine tapping and reaming) rose reamers (high speed steel blades are inserted as shown in Fig. 3), cross-head reamers (inserted first carbon blades), knuckle joint ream-

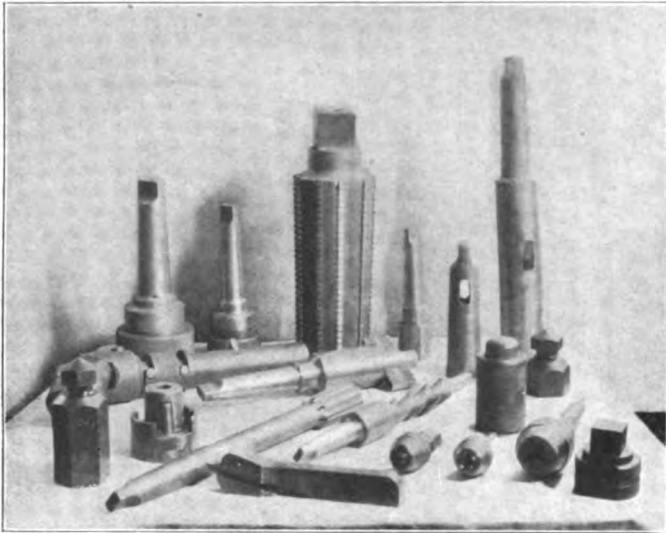

Fig. 4—Group of Tools in Which Casehardened Machine Steel Has Been Used with Success

ers (inserted high speed blades), washout plug taps (inserted carbon steel blades), counterboring tools (inserted high speed blades), and machine tool holders (case-hardened for holding inserted high speed bits).

Fig. 4 shows a group of tools made of soft steel, the more expensive material being inserted.

RESULTS OF THE LOCOMOTIVE BOILER INSPECTION LAW*

BY FRANK McMANAMY

Chief Inspector, Locomotive Boilers, Interstate Commerce Commission,
Washington, D. C.

The results so far obtained from the locomotive boiler inspection law are due to a number of reasons, among which are more careful inspection, more prompt repairs and attention to minor defects, investigation and classification of every accident that resulted in injury, with a view to determining the cause and remedying it, and giving publicity to the information collected.

No railroad man with a trace of honesty and a knowledge of conditions and practices prior to the passage of the law can question that, generally speaking, inspections are now made more carefully and more regularly, and repairs are more promptly made, and further that the question of repairs is less apt to be determined by the number of loads in the yard awaiting movement, although unfortunately that is still occasionally considered to be the deciding factor; an illustration being a recent request by a master mechanic to operate a locomotive with 43 broken staybolts a distance of 312 miles, because they needed the power. It must be admitted, however, that such instances are becoming more rare, although we still occasionally find a superintendent or trainmaster who, in spite of the fact that he is at the other end of the division, considers himself a better judge of the condition of a locomotive than an inspector or foreman who is on the ground, and orders it into service regardless of its condition.

*From a paper presented at the March meeting of the Western Railway Club.

The importance of giving attention to minor defects can be shown by a single illustration. During the last fiscal year 18 persons were injured, due to studs blowing out of firebox or wrapper sheets. The practice of repairing leaky studs by caulking, or permitting them to continue in service without repairs, should be discontinued.

I have recently had occasion to read very carefully statements made before Congressional committees at the time the boiler inspection law was pending, to the effect that all boiler explosions were really crown sheet failures due to low water; therefore, were man failures. In order to correct this misapprehension, attention is directed to the records of such accidents since July 1, 1911.

During the year 1914, as compared with 1912, accidents which are usually termed boiler explosions which resulted in injury have decreased 44 per cent, or from 97 in 1912 to 54 in 1914, and the number of killed and injured has decreased 64 per cent, or from 290 to 104. During the same period crown sheet failures due to low water decreased 48 per cent, or from 92 to 48. I am directing attention especially to this class of accidents, first to show that the class of accidents which were said to be unpreventable have been materially reduced, and also because our investigations have shown that by proper application and maintenance of boiler appurtenances they can be still further reduced.

Rule 42 provides that, "Every boiler shall be equipped with at least one water glass and three gage cocks. The lowest gage cock and the lowest reading of the water glass shall be not less than 3 in. above the highest point of the crown sheet." While it may be a compliance with the letter of the law to locate these appurtenances where they can be most easily applied, regardless of their convenience to the enginemen, it is manifestly not a compliance with the intent of the law, and is not conducive to safety, as an improper or inconvenient location may seriously interfere with their proper use. A certain type of locomotive has the water glass located directly behind the engineer and entirely out of sight of the fireman. In other instances glasses are found so obscured by other boiler appurtenances or by an improper shield that it is difficult, and under certain conditions, impossible to see the water level. A recent investigation of a crown sheet failure showed that the cab arrangement was such that the water glass and gage cocks were 9 in. above the engineer's head and that he regularly carried a small keg to climb upon to try the gage cocks. Can it be seriously questioned that such conditions cause accidents, particularly when operating in a busy terminal? Using a shield that obstructs the view of the water glass is also too common. The manner of application is also important, both as to water glasses and gage cocks.

We also find that the manner in which gage cocks and gage cock drippers are applied indicates that the purpose for which they were applied did not receive sufficient consideration. While the application of a dripper is important to prevent the discharge from the gage cocks from scalding anyone in the cab, it should not be located so close to the gage cocks that the nipples extend down into the dripper, preventing enginemen from seeing the discharge, as dripper pipes occasionally become obstructed and fill with water, in which event the sound of water and steam are identical.

Failure of injector steam pipes continues to be one of the most frequent causes of serious accidents, and is the only one which shows an increase during the present fiscal year over the corresponding period for the previous year. To bring out clearly the cause of these failures, the following is a complete list of all that have occurred since July 1, 1914, and which resulted in 1 killed and 15 injured, showing the cause of each:

INJECTOR STEAM PIPE FAILURES, JULY 1, 1914, TO MARCH 1, 1915

1. Collar broke on right injector steam pipe, due to old crack in collar.
2. Steam pipe to left injector blew off where brazed to collar.
3. Injector steam pipe blew off; union nut broke while being tightened

under pressure, due to defective nut and use of improper tools for making repairs.

4. Threads stripped in injector steam pipe union nut while being tightened under pressure; nut too light and threads badly worn.

5. Injector steam pipe blew off; union nut broke while being tightened under pressure.

6. Union to left injector steam pipe blew off, fatally scalding fireman who was attempting to tighten it under pressure; spanner nut too large.

7. Steam pipe to left injector pulled loose at turret connection due to defective brazing and injector not properly braced.

8. Left injector steam pipe collar broke at injector throttle connection; old crack in flange of collar and wrapped with asbestos to stop leak.

9. Injector steam pipe collar broke; defective collar.

10. Injector steam pipe spanner nut broke while being tightened under pressure.

11. Spanner nut on injector steam pipe broke while being tightened under pressure. Nut had been badly damaged previous to accident by use of hammer and set.

12. Injector steam pipe pulled out of collar; improperly brazed.

13. Spanner nut on left injector steam pipe broke while being tightened under pressure; due to use of improper tools.

14. Injector steam pipe broke at brazing.

15. Right injector steam pipe collar broke; defective collar.

16. Injector steam pipe collar broke; defective collar.

The nine failures, four of which were due to poor brazing and five to collar or sleeve breaking, can, I believe, be prevented by extending the pipe through the collar or sleeve and flanging or beading it, thus reinforcing the collar and reducing the strain on it, as the end of the pipe itself will be solidly held in the joint; therefore, it will carry the load. If properly applied in this way, brazing is not necessary, although it can be done if desired. This method of application is at least as cheap as brazing, and defective or improper workmanship can be discovered by inspection, which is impossible with the brazed connection.

There are other results, more or less indirect, but of substantial benefit to the carriers, among which are a reduction in the number of engine failures, as we have numerous records of locomotive performance which show an increase of from 200 to 800 per cent in the miles per failure since the law became effective, which it is admitted is largely due to improved conditions resulting from the stimulating effect of the law. A saving in fuel is another result of the improved conditions brought about by compliance with the requirements, among which are prohibiting the use of flue plugs and providing that boilers must be more carefully washed, and must have all scale removed from them when in the shop for repairs, and that leaks both inside and outside of the firebox must be kept to the minimum.

Failure to properly wash and scale boilers is another evil which had grown to alarming proportions, due perhaps to the fact that washing or scaling a boiler is among the most disagreeable tasks around a shop, and is too often performed by incompetent or indifferent labor not properly supervised. In addition to being one of the chief causes of leaking crown and staybolts, tests have shown that $\frac{1}{8}$ in. of scale on heating surfaces results in a loss of approximately 15 per cent of the value of the fuel; therefore, clean boilers mean in addition to increased efficiency a saving in cost of fuel as well as in the cost of repairs.

While it can not be doubted that the remarkable decrease in the number of casualties and the improved conditions noted, as well as many others are a direct result of the operation of the law. I do not wish to be understood as claiming that those who are administering the law are entitled to all credit for the improvement shown. Such results could not have been accomplished without the co-operation of the railroad officers, which we have in a great measure received. However, co-operation does not mean that we should ignore defective conditions and permit locomotives to remain in service in violation of the law, and that will not be done; it does not mean that attempts should be made to conceal defects by making improper inspections or by certifying to reports which do not represent actual conditions.

DISCUSSION

Mr. McManamy also called attention to the desirability of having the opening in the boiler for the bottom water glass fitting above the crown sheet, for if any obstruction occurred in the top connection the gage glass would not drain until the water was below the crown sheet. Cases were mentioned where hostlers and fire-up men used the bottom water glass cock for an indication of a sufficient amount of water for firing-up, and under the above conditions it is evident that there would be no water on the crown sheet. It was also pointed out that the circulation of water through the arch tubes would, if the glass was located near them, influence the height and give a false reading causing racing or a fluctuation of the water in the glass. M. D. Franey stated that he has eliminated the trouble with racing, due to the circulation of the water through the arch tubes, by cutting off the inside ends of the water glass cocks at an angle of 45 deg. In this way there is a shelf below the water glass cock opening that would protect the water just above it from the effect of this circulation. He also stated that it is preferable to insert the gage cocks and water glass connections on sloping boiler heads horizontally rather than at right angles to the boiler sheet.

The subject of leveling boilers for the application of gage cocks and water glasses was discussed and the majority of the members speaking on this subject believed that the rubber hose and water glass method was the most satisfactory, the boiler, of course, having been leveled with the frame.

In answer to a question regarding the use of flue thimbles, Mr. McManamy stated that the government has made no restriction on their use, that matter being left to the judgment of the men, but if it were found that this practice was being abused, action would be taken concerning that particular case. Regarding the reporting of alterations, he believed that this rule was somewhat misunderstood, and that if the rules were read more carefully much of the unnecessary reporting could be eliminated.

PORTABLE RIVET FORGE AND BLOW TORCH

BY W. S. WHITFORD

General Foreman, Chicago & North Western, Milwaukee, Wis.

The accompanying illustration shows a portable rivet forge and blow torch which was designed by E. J. Nicholson, the boiler foreman at this point, for use in the roundhouse. Fuel oil is used and air can be obtained either from a locomotive

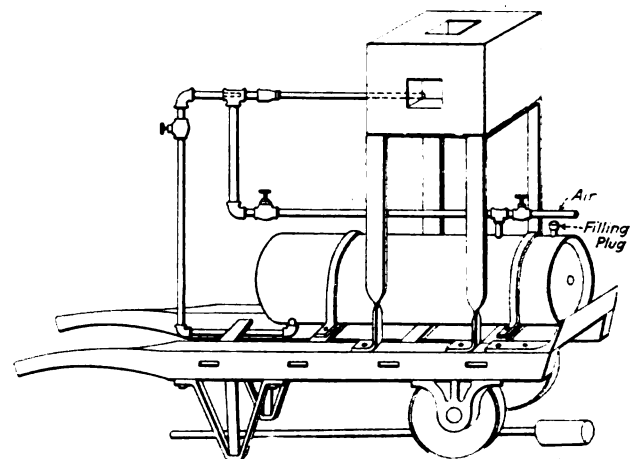

Portable Forge and Blow Torch for Use in Roundhouse

or the roundhouse air line. The forge is made up of a 12 in. by 40 in. air drum securely fastened to an old truck and the fire pot extends up over the drum as shown in the illustration.

The blow torch is very useful in straightening front frames, running board brackets, tank angle irons and heating frames for thermit welds. It is used by unscrewing the small pipe at the reducing bushing which leads to the furnace and attaching a hose leading to the torch. This apparatus is very easily made, and old material can be used. It will pay for itself in a very short time.

POST CLUSTER FOR EXTENSION CORD PLUGS

BY F. W. BENTLEY, JR.

It is often necessary for a number of individual extension lights to be used by men working on the same job in the erecting shop. The illustration shows a plate to which are secured a number of plug boxes to which several extension cords may be attached. By the location of such plates at suitable intervals all extension lights may be attached to plugs near the work, thus providing greater safety than is possible where long cords are

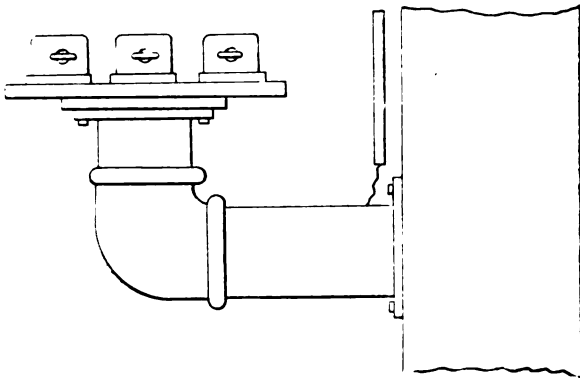

Terminal Boxes for Extension Cord Plugs

used with the connections at some distance from the work. With the long cord there is always the possibility that the plug may be accidentally pulled from the box at a time when failure of the light may result in injury to the user. The support is made of 2-in. pipe through which the wiring is conveyed from the post to the boxes.

USING OLD BOILER TUBES AS PIPE

BY J. P. NOLAN

Assistant Superintendent, Morgan's Louisiana & Texas Ry., Algiers, La.

Efforts have been made to make pipe lines for steam, water, air, etc., from old boiler tubes by swaging down the ends of the tubes to pipe size and threading them or by welding short pieces of pipe to the ends of the tube and threading the ends of the

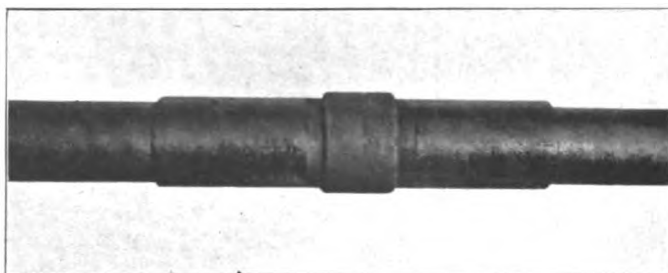

Old Boiler Tubes Joined by Standard Pipe Coupling

pipe. Satisfactory results have not always been obtained by the first method, however, because the worn tubes are often too thin to form a substantial joint after being threaded. The illustrations show an effective means of joining old tubes. A piece of gas

pipe about equal in length to twice its outside diameter, one end of which is threaded, is slipped over the end of the tube. A tight joint is made by expanding the tube near each end and in the middle of the pipe with a roller tube expander, care being

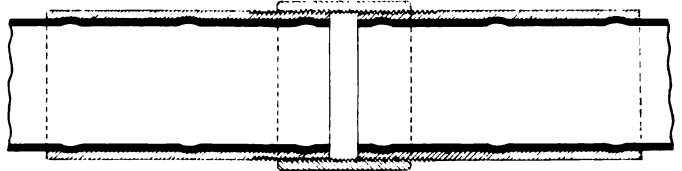

Ends of Tubes Expanded into Short Pieces of Pipe

taken not to enlarge the size of the thread by too tightly expanding the tube at these points. In this manner the ends of old tubes may be readily adapted to receive standard pipe fittings and may be used to build substantial pipe lines about the shop.

FIXING STANDARD TIME FOR A BONUS SYSTEM*

The bonus system was established in one department of the Atchison, Topeka & Santa Fe shops, at Topeka, in 1904, by Harrington Emerson. At the beginning an effort was made to establish a really scientific system. Each operation was carefully observed and timed with stop watches and standard tasks were so set.

"In the latter part of the year 1906," says the company's booklet explaining its bonus system, "it was decided by the management from experience thus far gained, that better results would be obtained by adopting the simplified Santa Fe efficiency plan. This simplified plan among other things involved the abandonment of timing operations with stop watches and the installation of a system for fixing rates by a staff of bonus supervisors said to know the work thoroughly. To quote one of the officers of the company "our supervisors have become so proficient that they know by looking at a process the time it should be done in, and they can set the rates more accurately than by using stop watches."

Few reputable efficiency engineers would accept such a statement without much questioning. In fact it seems self-evident that no method of fixing standard time by observation—no matter how skilled the observer—can be as accurate as one in which every movement in the performance of each task is carefully and repeatedly timed under varying conditions. Changes in locomotives and in methods of manufacture are continually producing new jobs which may in part be resolved into certain elements that are common to old operations, and so can be easily adjusted. But especially in repair work, new tasks differing from old ones are constantly coming up, which make necessary new schedules for payment. In the Santa Fe shops these schedules are made by one person who determines what shall be paid. Under these conditions, therefore, there is all the more reason for working out a system for fixing rates that will be precisely fair and just to the men dealt with.

Moreover, under the present plan, which has eliminated the timing of separate parts of each operation, there is not the same opportunity which existed under the earlier plan for each worker to determine the fairness and accuracy of the company's standard by means of testing for himself the time fixed for each part of his task. This is especially important in a shop like those on the Santa Fe where there is no method for collective representation of employees' interests when the process of "standard time" setting is going on.

Men doing their tasks in standard time are said to be 100 per cent efficient and those achieving over 66.7 per cent efficiency earn bonuses according to their output. "At 66.7 per cent ef-

*Extract from a report by Zenas L. Potter of the Department of Surveys and Exhibits, Russell Sage Foundation, on Industrial Conditions in Topeka.

iciency." the company's explanatory booklet states, "the company acknowledges having obtained value received for the hourly wages paid." The presumption is—and this is in accord with the principles of the bonus system—that those below 66.7 per cent efficiency do not return "value received" for their regular wages. In other words, save for a few who may be exactly 66.7 per cent efficient, those who are unable to earn bonuses must be a direct loss to the company. In an efficiency system those failing to earn bonuses become for this reason subjects for special investigation, and if their failings continue, for discharge.

An investigation for the month of October, 1913, showed that while 60 per cent of the workers earned bonuses, 40 per cent did not. If the point where bonus earnings begin marks the point where the company receives value for regular wages, then the great majority of the 541 workers, making up this 40 per cent (except for a few who may have been exactly 66.7 per cent efficient), must have been a direct loss to the company. It is not likely, however, that men whose product is of lower value than their wages would be continued at work, and the presumption must be that 66.7 per cent efficiency does not mark the point at which the company gets "value received" for regular wages. Thus it appears that the methods of fixing the task which the workers must perform before beginning to earn bonuses is neither accurate nor scientific.

Another fact was brought out. The percentage of men able to earn bonuses varies greatly from trade to trade. Only 50 per cent of the boiler makers, for instance, 45 per cent of the pipefitters, and 37 per cent of the car repairers, as against 100 per cent of the cabinet makers, 97 per cent of the painters, and 89 per cent of the blacksmiths were able to make this extra pay. These very wide variations indicate that "standard time" has not been adjusted so as to reward equally relative equality of skill in the different trades and suggests that methods for fixing standards are far from being accurate or scientific.

FINISHING CAR AND ENGINE TRUCK BRASSES BY GRINDING

BY R. E. BROWN,

Machine Shop Foreman, Atlantic Coast Line, Waycross, Ga.

An economical method of preparing car and engine truck brasses for babbitting is in use at the Waycross shops of the Atlantic Coast Line. The brass patterns have all been made to finished size and the rough castings, instead of being bored, are taken to an emery wheel where all scale is ground away from the circle of the brass, leaving the bright, clean metal

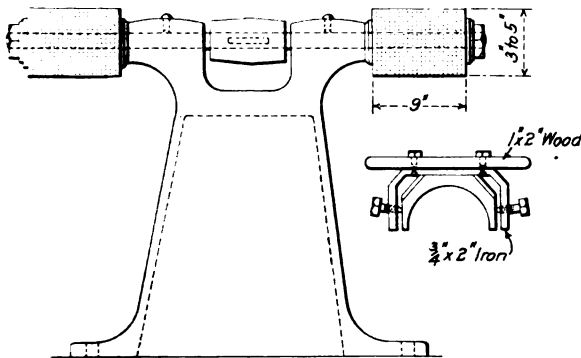

Grinding Wheel for Finishing Car and Engine Truck Brasses

exposed. The brasses are then spotted on both sides of the center with one-half inch holes, filled to a depth of one-quarter inch from the drill point. They are then placed upon a form and babbitted. This method has been in use for more than a year with excellent results, and the cost of doing the work is

much lower than by the old method of boring all brasses. The wheels used are five inches in diameter by nine inches long and are mounted on a double wheel stand as shown in the drawing. A simple device is used for handling the brass while it is being ground and is readily attached to and removed from the brass by means of two set screws. By this method an unskilled helper is able to finish from 25 to 30 brasses in an hour, whereas when boring the brasses the output of a mechanic was about 12 per hour.

TURNING ENGINE BOLTS

BY C. L. DICKERT

Assistant Master Mechanic, Central of Georgia, Macon, Ga.

A system of standard engine bolts and reamers has been adopted by the Central of Georgia, and a machine tool group installed at the Macon shops especially for the manufacture of bolts on shop orders for stock.

Bolts are made on shop orders in quantities of from 2,000 to 6,000, ranging in sizes as shown in the accompanying table. Occasionally small lots are made to fill in where the most used sizes in stock have been reduced. The diameter of the stand-

Bolt Number to be size of bolt under head in 32nds.

Bolt Number	Finished Sizes				Forging Sizes				
	Diam. Under Head A	Length Under Head B	Thick-ness of Head C	Across Flats D	Diam. Under Head A	Length Under Head B	Thick-ness of Head C	Across Flats D	
26	1/16	4, 6, 9, 12	3/32	1 1/2	3/32	1	4, 6, 9, 12	3/32	1 1/8
27	3/32	4, 6, 9, 12	3/32	1 1/2	3/32	1	4, 6, 9, 12	3/32	1 1/8
28	1/8	4, 6, 9, 12	3/32	1 1/2	3/32	1	4, 6, 9, 12	3/32	1 1/8
29	3/32	4, 6, 9, 12	3/32	1 1/2	3/32	1	4, 6, 9, 12	3/32	1 1/8
30	5/16	4, 6, 9, 12	3/32	1 1/2	3/32	1 1/8	4, 6, 9, 12	3/32	1 1/2
31	3/16	4, 6, 9, 12	3/32	1 1/2	3/32	1 1/8	4, 6, 9, 12	3/32	1 1/2
32	1/4	4, 5, 6, 9, 12	3/32	1 1/2	3/32	1 1/8	4, 5, 6, 9, 12	3/32	1 1/2
33	1/2	4, 5, 6, 9, 12	3/32	1 1/2	3/32	1 1/8	4, 5, 6, 9, 12	3/32	1 1/2
34	1/8	4, 5, 6, 9, 12	1/16	1 1/2	1/16	1 1/8	4, 5, 6, 9, 12	1/16	1 1/2
35	1/2	4, 5, 6, 9, 12, 15	1/16	1 1/2	1/16	1 1/8	4, 5, 6, 9, 12, 15	1/16	1 1/2
36	1/8	5, 6, 9, 12, 15	1/16	1 1/2	1/16	1 1/8	5, 6, 9, 12, 15	1/16	1 1/2
37	1/2	5, 6, 9, 12, 15	1/16	1 1/2	1/16	1 1/8	5, 6, 9, 12, 15	1/16	1 1/2
38	1/8	5, 6, 9, 12, 15	3/32	1 1/2	1/16	1 1/8	5, 6, 9, 12, 15	1/16	1 1/2
39	1/2	5, 6, 9, 12, 15, 18	3/32	1 1/2	1/16	1 1/8	5, 6, 9, 12, 15, 18	1/16	1 1/2
40	1/4	5, 6, 9, 12, 15, 18	3/32	1 1/2	1/16	1 1/8	5, 6, 9, 12, 15, 18	1/16	1 1/2
41	1/2	5, 6, 9, 12, 15, 18	3/32	1 1/2	1/16	1 1/8	5, 6, 9, 12, 15, 18	1/16	1 1/2
42	1/8	5, 6, 9, 12, 15, 18	1/16	2	1/16	1 1/8	5, 6, 9, 12, 15, 18	1/16	2 1/8
43	1/2	6, 9, 12, 15, 18	1/16	2	1/16	1 1/8	6, 9, 12, 15, 18	1/16	2 1/8
44	1/8	6, 9, 12, 15, 18	1/16	2	1/16	1 1/8	6, 9, 12, 15, 18	1/16	2 1/8
45	1/2	6, 9, 12, 15, 18	1/16	2	1/16	1 1/8	6, 9, 12, 15, 18	1/16	2 1/8
46	1/8	6, 9, 12, 15, 18	1/16	2 1/8	1/16	1 1/8	6, 9, 12, 15, 18	1/16	2 1/8
47	1/2	6, 9, 12, 15	1/16	2 1/8	1/16	1 1/8	6, 9, 12, 15	1/16	2 1/8
48	1/4	6, 9, 12, 15	1/16	2 1/8	1/16	1 1/8	6, 9, 12, 15	1/16	2 1/8
49	1/2	6, 9, 12, 15	1/16	2 1/8	1/16	1 1/8	6, 9, 12, 15	1/16	2 1/8

Standard Taper Bolt Sizes Used on the Central of Georgia

ard bolts under the head varies by 32nds from 13/16 in. to 1 17/32 in., and each size is designated by the number of 32nds in its diameter. The standard lengths range from 4 in. to 18 in.

All reamers are sized and marked at the large end, to correspond with the size of the bolt under the head, so that both can be ordered according to the size of the reamer. With this arrangement the hole is reamed to suit the bolt, and only in special cases where it is difficult to ream, is the bolt fitted to the hole.

The bolts are largely carried in store stock. However, in the erecting shop suitable bins are provided for a small number of

each size. Frequently only one or two bolts are needed and this saves special trips to the store house in such cases. When a number of bolts are needed for bolting up cylinders, new frames, etc., they are drawn from the store, cut to length,

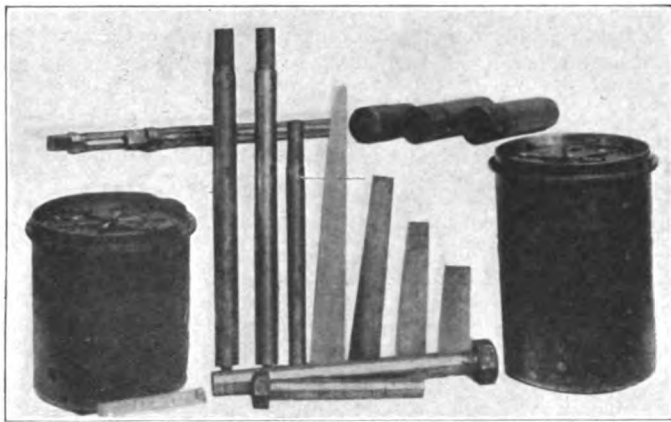

Cutter Heads, Blades and Gages for Adjusting the Heads; Hollow Gages for Testing Turned Bolts

threaded, and placed at the engine where the machinist reams the holes and drives them in.

The group of machine tools devoted to the finishing of bolts is made up of one 3-in pointer, a 4-spindle bolt turner, a bolt alterer, one triple head bolt cutter, one 14-in. and one 16-in. en-

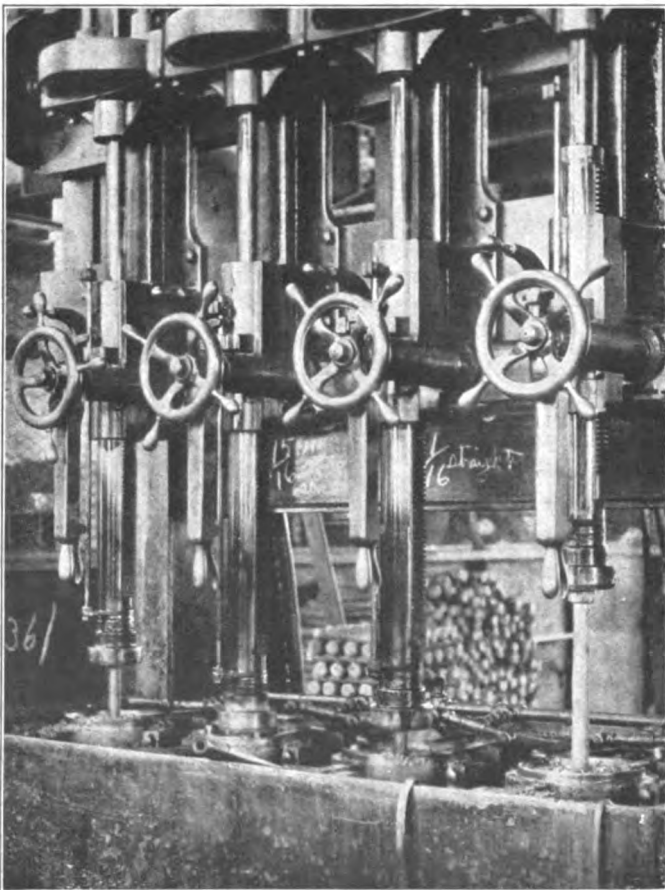

Four-Head Bolt Turning Machine

gine lathe, two center drills, and two nut facers. One of the illustrations shows a pile of rough bolts as received from the bolt header. They are first pointed in order that they will properly enter the cutter head of the bolt turning machine.

This has four heads and is shown in one of the illustrations. The cutter heads are located in the base of the machine, and the bolts are driven into them by revolving spindles. The cutter heads are fitted with removable blades which are adjusted for diameter and taper by means of plug gages. A set of hollow gages are also provided by which the turned bolts may be tested both as to the correctness of size and taper. The bolts are fin-

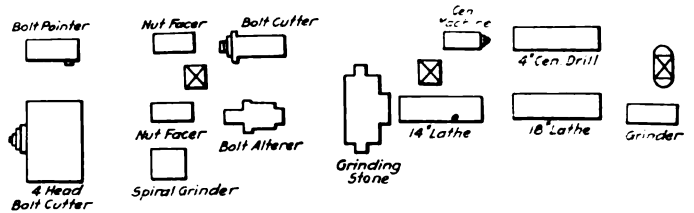

Group of Machine Tools for Finishing Engine Bolts

ished with one cut, no roughing cut being necessary, the average time required being less than one and one-half minutes for each bolt. When all four heads are working a 1 in. by 12 in. bolt is turned in one minute.

Bolts with countersunk and counterbored heads are made from the standard stock hexagonal head engine bolts. These operations are performed on the bolt altering machine which

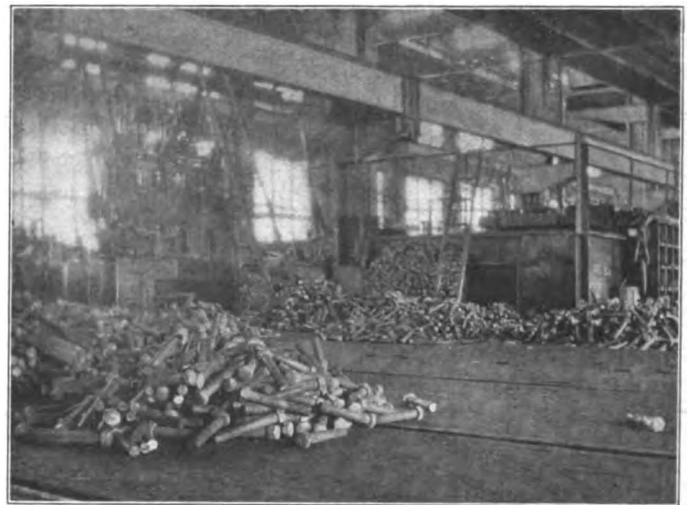

Rough Bolts Ready to Be Pointed

has two sliding heads operated by a hand lever giving a quick movement of tools. By this means two apprentices are able to more than keep ahead of special bolt fitting. Bolts are cut off to length in this machine and threaded on the bolt cutter.

All bolt machines, except the two bolt lathes, are operated by cheap labor, thus bringing the cost of bolt turning and fitting to a minimum.

CACTUS AS A BINDER.—The United States Patent Office has recently granted a patent to F. Meyer, of Denver, Colo., on a new binder for briquetting coal dust, coke breeze, flue dust and fine ores. The binder is the liquid extract of cactus, and its wide occurrence in all the southwestern states and its almost absolute uselessness for other purposes ought, according to the patentee, to furnish a binder cheaper than any other mentioned in the various publications of the Bureau of Mines on the subject of briquetting of fuel. There can be no doubt that cactus has excellent binding qualities. Any one who has ever had the misfortune to experiment with cactus knows that its pulp is as sticky as glue, and we also know that the extract of *Cactus opuntia* is often used as a substitute for tragacanth by confectioners.—*Engineering & Mining Journal*.

ANSWERS TO SOME QUESTIONS ON ELECTRIC ARC WELDING*

BY J. F. LINCOLN

The available literature on arc welding is very incomplete, and gives but little information to the man who might apply arc welding to his product. The object of this paper is to consider the fundamental principles of arc welding so that the manufacturer can decide for himself the following questions:

1. What metals can be welded by the electric arc?
2. What difficulties are encountered in electric arc welding?
3. What is the strength of the weld in comparison with the original piece?
4. What is the cost of welding?
5. What is the function of the arc welding machine?
6. How does electric welding compare with oxy-acetylene and other similar methods?

All metals can be welded. Any two pieces of metal which are brought into contact at their melting temperature will adhere so that they are no more liable to break at the point of junction than at any other point. The electric arc is used in the process merely as a heating agent, and this is its only function. It is superior to any other method of heating because of its ease of application and the economy with which heat can be concentrated at any given point by its use.

The difficulties which are encountered in welding are the following: Formation of oxide; expansion and contraction under heat; burning through. In the case of brass or zinc, the heated parts will be covered with a coat of oxide before they come to a welding temperature. This makes it impossible for two clean surfaces of the metal to come into intimate contact. Some method must be adopted for disposing of this oxide at the weld and allowing the two surfaces to be welded to come together without the possibility of oxide being included between them. This condition obtains in the welding of aluminum and of a great many alloys. In order to eliminate this coat of oxide it is usually necessary to puddle the weld, that is, to have enough of the metal melted at the weld so that the oxide is floated away from it. When this is done, the two surfaces are covered by a coat of melted metal on which the oxide floats, thus allowing two clean surfaces of metal to come together. This precaution, however, in the case of steel is not usually necessary.

Another difficulty with arc welding is that very thin pieces of metal are very liable to burn through, leaving holes where the weld should be. This difficulty can be avoided by backing up the weld with a metal face to carry away the heat, or by decreasing the intensity of the arc so that the melting through will not occur. The limiting thinness of metal to which arc welding can be applied without metallic backing is approximately 22 gage.

The next difficulty with arc welding is the lack of skillful operators. Manufacturers sometimes do not give the operators a chance to master the process before making up their minds that the method is not feasible. If the same point of view were held in regard to welding by means of the forge fire, blacksmithing would never have come to be practiced. It does not require as skillful handling to make a good arc weld as it does to make a weld on an anvil, and there are very few electric welds that cannot be handled successfully by an operator of average intelligence with one week's instruction.

The strength of the weld is equal to that of the metal of which the weld is made. It should be remembered, however, that the metal which goes into the weld is really a casting, and has not been rolled. This means that the strength of the weld would be equal to that of the same metal that is used for filling, if used in the form of a casting. There are a great many welds where it is possible to make the section at the weld a little larger than the section of the rest of the piece. The disadvantage of the

weld being in the form of a casting can thus be overcome.

There are no doubt some cases where the use of a drop hammer and a forge fire and the oxy-acetylene blow torch will make, all things considered, a better job than the use of the electric arc. However, the electric arc will melt metal in a weld for from 3 to 30 per cent of the cost of melting it with the oxy-acetylene blow torch, on account of the fact that the heat can be applied exactly where it is required, and in any amount that is required.

It is practically out of the question to apply the alternating current to arc welding since one electrode must always remain positive. In welding by means of the carbon arc, the piece to be welded is made the positive electrode, while with a metallic arc either the piece to be welded or the filler may be made the positive electrode. With a carbon electrode the voltage will vary from 0 to 45 volts; with the metallic electrode from 0 to 30 volts.

The simplest welding machine is an ohmic resistance in series with the arc. This is entirely satisfactory except in regard to the cost of current. By the use of resistance in series with the arc on a 220-volt supply circuit, from 80 to 90 per cent of the current is dissipated as heat in the resistance.

Practically all arc welding machines now in use consist of motor-generator sets, the motor of which is adapted to the existing supply circuit, and is direct connected to a compound-wound generator delivering current at approximately 75 volts, which is applied to the arc in series with a resistance. Considerable saving is effected by this method over the use of a resistance in series with the full supply voltage. It is possible to construct a machine that will eliminate these losses by avoiding the use of a resistance in series with the arc. A machine of this kind will save its cost in a short time, provided it is in steady use.

The following figures give the approximate cost of power for operating arc welding machines under average conditions, which are assumed as follows: Cost of current, 2 cents per kw-hr.; metallic electrode arc of 150 amperes; carbon arc of 500 amperes; voltage across the metallic electrode arc 20; voltage across the carbon arc 35; supply circuit 220 volts direct current; a single resistance in series with the arc. With the metallic electrode, the cost of energy will be 66 cents per hour; with the carbon electrode \$2.20 per hour. If a motor-generator set with a 75-volt constant potential machine is used for a welder, the cost will be for the metallic electrode 25.2 cents per hr., and for the carbon electrode 84 cents per hour.

With a machine which will deliver the required voltage at the arc without the use of a series resistance the cost will be for the metallic electrode, 7.2 cents per hour, and for the carbon electrode 42 cents per hour. These figures assume that the arc is held continuously at its full value. This condition, however, is impossible in practice, and the actual load factor is approximately 50 per cent, which means that, as a welder is usually operated, the actual cost of operation will be about one-half of the amounts given above.

FINISHING CYLINDER COCKS

BY R. E. BROWN

Machine Shop Foreman, Atlantic Coast Line, Waycross, Ga.

A cylinder cock body in use on the Atlantic Coast Line is shown in one of the accompanying drawings. A special drill and reamer and a pneumatic chuck are used in finishing the

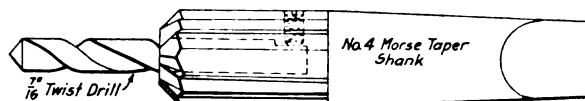

Combination Tool for Finishing Cylinder Cocks

valve seat, valve stem guide and threaded connection of the cylinder cock. The chuck consists of an angle plate back of which is an air cylinder by means of which the castings are clamped in position. Recesses in the face of the chuck con-

*Abstract of a paper read before the American Institute of Electrical Engineers, Cleveland, Ohio, March 18-19, 1915.

form to the cylinder cock bodies so that they are held rigidly in position. Two castings are chucked at one time and are finished with the combined drill and rose bit reamer shown in one of the illustrations. The reamer is provided with a recess in

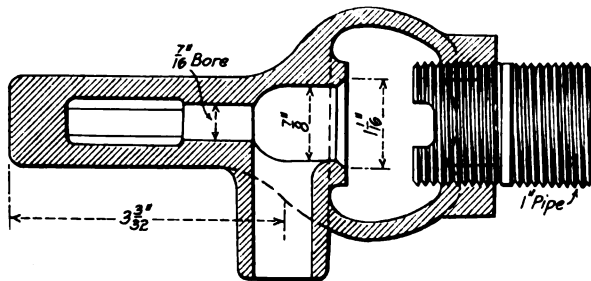

Cylinder Cock Used on the Atlantic Coast Line

the end in which is inserted a 7/16-in. twist drill, a small set screw in the reamer holding the drill shank in place. The drill finishes the valve stem guide and the reamer faces the valve seat and finishes the threaded connection at the top of the cylinder

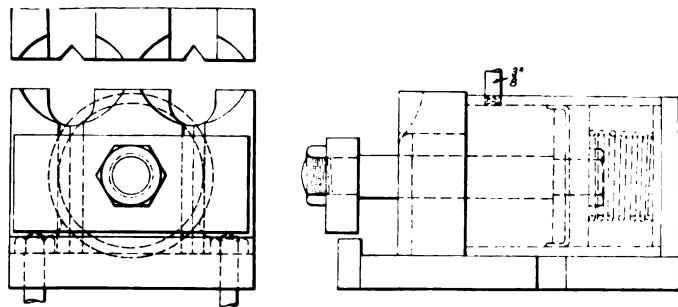

Chuck Used With Atlantic Coast Line Cylinder Cock

der cock body. After the reaming operation is completed the threads are tapped, both operations being done on a drill press by a handyman, who can finish about 25 castings per hour.

BORING FRONT END MAIN ROD BRASSES

BY C. H. ANDRUS

Master Mechanic, Pennsylvania Railroad, Harrisburg, Pa.

The jig shown in the illustration was developed and applied to an obsolete horizontal boring mill to increase the output and reduce the cost of finishing front end main rod brasses. By its use seven sets of brasses are finished at one time. They are en-

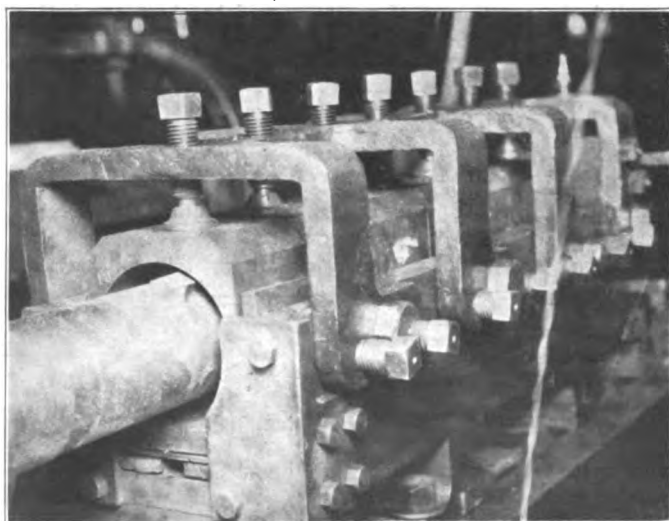

Jig for Boring Front End Main Rod Brasses

tered at the end of the jig, set in position with liners and securely clamped at the top and sides by set screws with swivel ends. They are then finished with a roughing and a finishing cut. In this way seven sets of brasses can be set up, lined and clamped in position, the two cuts made and the brasses removed from the

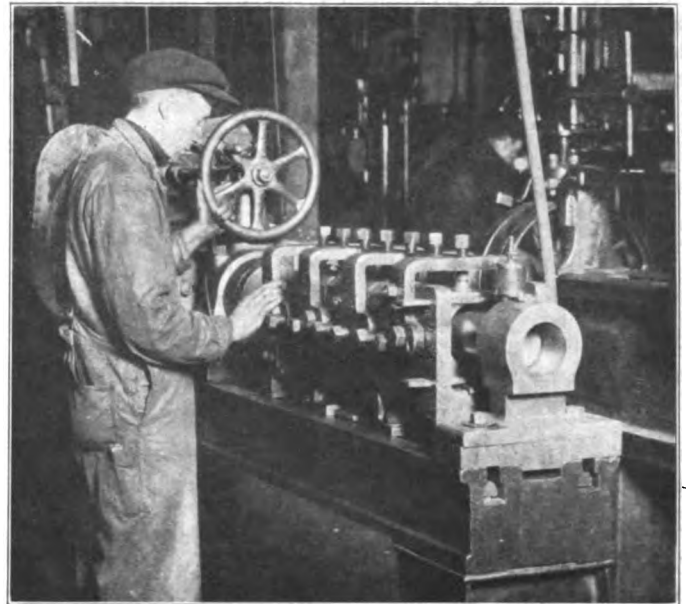

Front End Main Rod Brasses Set Up in Old Horizontal Boring Mill

machine in 21 min. With the former practice of finishing the brasses on a lathe, one set at a time, to finish seven sets required 13 hr. The work of this machine has proved very satisfactory.

SPECIAL CHUCKS FOR A TURRET LATHE

BY W. W. ELFE

Machine Foreman, Central of Georgia, Macon, Ga.

The illustration shows three chucks designed for use in turning and threading front end main rod keys and fire door latches on a turret lathe. The body of each chuck is designed to fit the body of the piece to be machined, leaving the end to be threaded

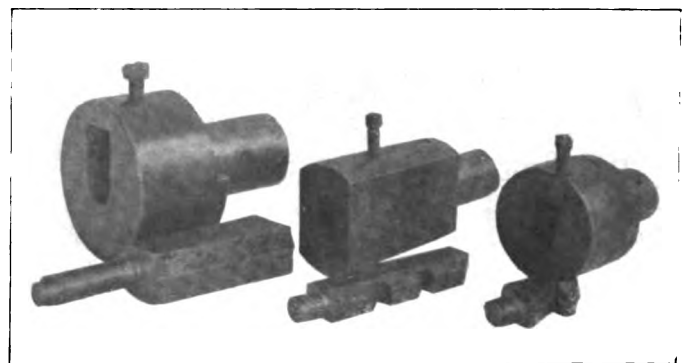

Chucks for Threading Fire Door Latches and Front End Main Rod Keys in a Turret Lathe

projecting beyond its face. When in position the work is secured by means of the set screws shown in the illustration. The chucks are provided with cylindrical shanks by means of which they are held in the automatic chuck of the turret lathe.

MANGANESE ORE.—Russia's export of manganese ore for the first nine months of 1914 were 737,149 tons against 817,345 tons for the same period in 1913. Imports of coke were 512,000 tons to October 1, 1914, compared with 687,000 tons in the same period in 1913.—*Iron Age*.

NEW DEVICES

OXY-ACETYLENE EQUIPMENT

Among the considerations of special importance in oxy-acetylene welding or cutting are the thorough and uniform mixing of the two gases employed and the close regulation of both the volume and velocity of the gases delivered to the mixing chamber of the torch. In the oxy-acetylene equipment recently placed upon the market by the Imperial Brass Company, 528 South Racine avenue, Chicago, the principle on which the oxygen and acetylene are mixed assures a high degree of uniformity in the mixture as it leaves the torch. Before entering the mixing chamber the oxygen at high velocity passes through

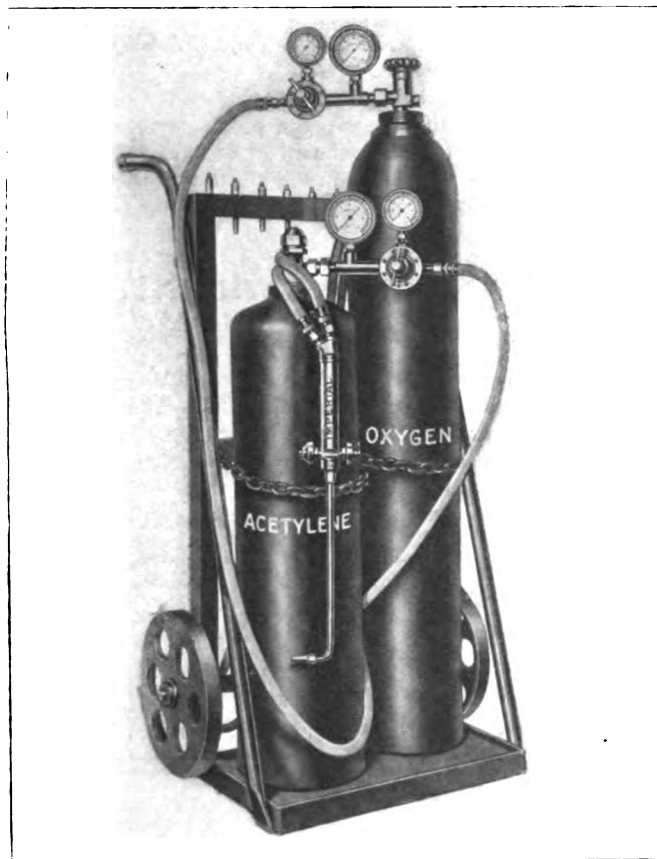

Portable Oxy-Acetylene Welding Equipment With Interchangeable Tips

a spiral groove which imparts to it a whirling motion. This causes the oxygen to mix thoroughly with the acetylene and effects a uniform mixture of the gases before they reach the point of combustion. The result is claimed to be a saving in oxygen and a flame of greater intensity both with the welding and the cutting torches.

The Imperial torches are fitted with interchangeable tips which are designed to cover all ranges of work within the limit of the oxy-acetylene process. The torches are durable in construction, no solder being used in their construction. The gas mixture is controlled by needle valves which admit of fine adjustment and are so located that the operator may readily adjust the flame with the hand which holds the torch, making it unnecessary to lay aside the welding stick. Both welding and cutting tips are made of a special alloy with an extremely high melting point and all threads and other dimensions are standard.

New tips for temporary use can readily be made in any machine shop from ordinary rod brass, so that the torch can be kept in service until new tips are secured.

The pressure regulators included in this equipment are designed to deliver to the torch a constant predetermined volume of gas at a constant velocity, and the movement of the valve with relation to its seat is so limited as to prevent cutting of the seat, thus insuring long life. The regulators are designed to automatically shut off in case of emergency.

SMALL SINGLE ACTING HYDRAULIC PUMP

To meet the demand for an inexpensive hydraulic pump delivering a small quantity of water and still capable of exerting a high pressure, the pump shown in the illustration was designed by the Hydraulic Press Manufacturing Company, Mount Gilead, Ohio. It is especially adapted to service requiring a steady, uniform flow of a small quantity of water under high pressure. On account of its light weight, when motor driven, it may be mounted on a truck and be used as a portable pump for operating small hydraulic shop tools on which no pump is mounted. It is provided with a knock-out attachment which automatically cuts off the delivery of water to the press ram, but maintains the pressure when a pre-

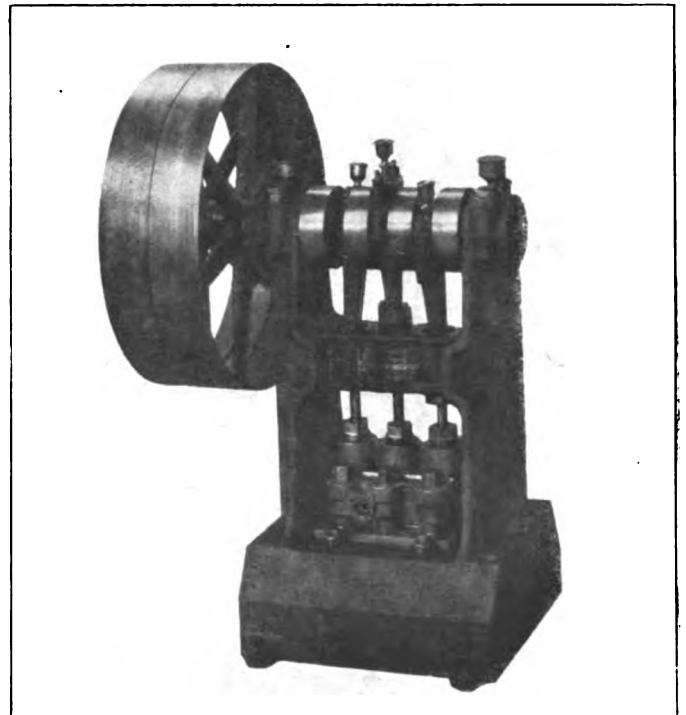

Small Single Acting Triplex Pump

determined maximum pressure is reached. A slight drop in the pressure automatically starts the flow, which continues until the maximum pressure is again reached. The base of the pump forms a reservoir for the liquid used in its operation. It is built for either gear, chain or belt drive.

The design of this pump is such that any one of twelve different size plungers may be furnished. These range from 3/16 in. to 1 in. in diameter, advancing by increments of 1/16

in. The maximum pressure which may be obtained ranges from 750 lb. to 8,000 lb. per sq. in., the larger the plunger diameter the lower the pressure capacity. The pump is single acting. The three plungers are of the same diameter and work to the same maximum pressure. The stroke is $2\frac{3}{4}$ in. Each plunger has a speed of 35 ft. per min. at 150 strokes per min., which is the rated speed. When driven at this speed the pump has a capacity of .41 gal. to 4.20 gal. per min., depending upon the diameter of the plungers. The suction and discharge valves are located in the pump cylinder.

The frame is cast in one piece of semi-steel; the cross heads are of cold rolled steel. The connecting rods are made of malleable iron with bronze bearings. The pump plungers are naval bronze, with the exception of the $\frac{5}{16}$ in. and $\frac{3}{8}$ in. sizes, which are of steel, to withstand the high pressure, and with which forged steel cylinders are used. Other sized cylinders are cast en bloc, for plunger diameters larger than $\frac{3}{8}$ in., a special bronze being used. The pump has a height over all of 35 in. and occupies a floor space of 16 in. by 18 in. The weight without motor base or belt shifter is only 500 lb.

QUINTUPLE PUNCHING AND SHEARING MACHINE

To meet the demand for a combination machine that will handle the punching, shearing and notching work met with in structural shops, car shops and ornamental iron working shops, the machine shown in the illustration was recently developed by Jos. T. Ryerson & Son, Chicago. This machine embodies the functions of five metal working machines in one. It handles punching, shearing, coping, notching operations on plates, bars and structural sections without the necessity of interchanging

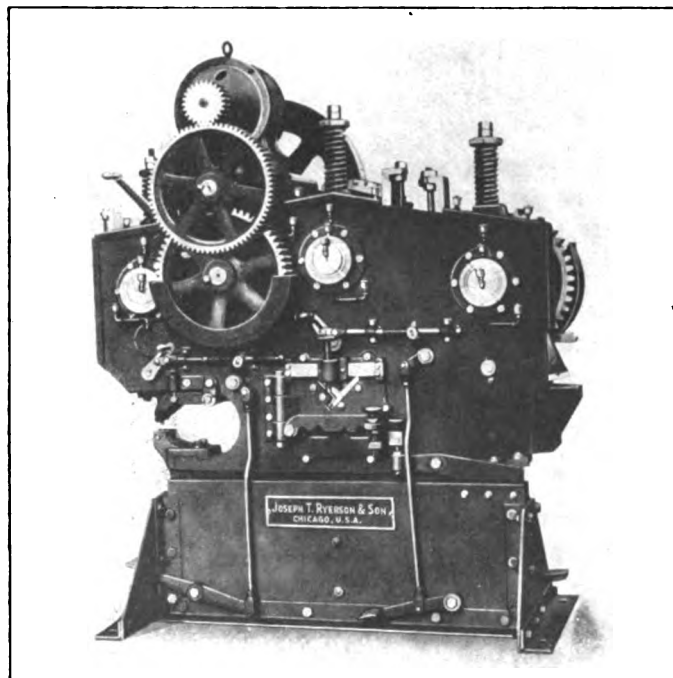

Combination Punching and Shearing Machine

any attachments. The punch and bar cutter as well as the splitting shear may be operated independently by clutches which may be thrown in either by hand or foot.

The frame of the machine consists of a solid steel offset shear body, the construction of which permits the cutting of plates of any width or length. An adjustable hold-down is provided with the splitting shear. The bar cutting device is provided with an arrangement which permits the shearing of angles and

tees as well as both round and square bars without changing the blades. The shape of the upper blade for shearing angles and tee-bars is such that small and light sections may be cut without bending. The stationary blades of the bar and angle cutter are mounted in a hinged frame which may be swung back from the side of the machine permitting easy removal of the blades for grinding. The shear blades are each made in four sections instead of one which greatly simplifies maintenance. Adjustable hold-downs permit the cutting of various material to a perfect right angle and a special attachment is provided which permits intercutting up to an angle of 45 deg.

The punch is equipped with the standard architectural jaws, which permits the punching of I-beams and channels, both in the flanges and in the web. A patented centering device is furnished which permits the centering of the punch to the full length of the stroke. The material is stripped from the punch by a universal hold-down. The splitting shear is provided with an extension to the sliding head which receives the die blocks for coping and notching work. This is of rectangular shape and permits not only the coping of light I-beams and channels, but the notching of other sections and material used in stair, fire escape or other ornamental work.

This machine is especially adapted to shops which do not have sufficient work to justify the expense of separate tools for the various operations referred to above. It is furnished for either belt or motor drive. As shown in the illustration the direct motor driven machine is provided with a bracket at the top to which the motor is secured.

EXHAUST NOZZLE WITH INTERNAL PROJECTIONS

A new design of exhaust nozzle has recently been developed in the Pennsylvania locomotive testing plant at Altoona, Pa., by means of which considerable increase in locomotive capacity has been effected. It has been patented by F. A. Goodfellow.

The new nozzle has a circular opening with four projections of triangular section, each of which extends out $1\frac{1}{8}$ in. from

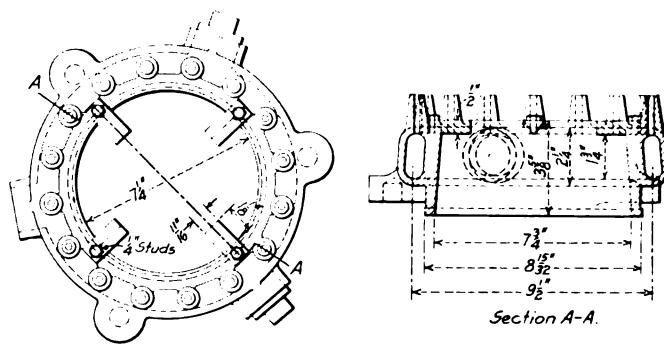

Internal Projection Exhaust Nozzle

the periphery of the opening, and is $\frac{11}{16}$ in. in width at its top face. The projections diminish the area of the opening 3.44 sq. in. in the nozzle shown in the drawing. They are machined to size and fastened in place with studs so that the apex of each piece points in a downward direction, but will be drop forged in the future, thus saving the cost for machining; they will also be fastened permanently in place by electric welding. This will make it impossible to either increase or decrease the size of the opening without breaking off the welded projections and will eliminate the tendency to make unauthorized changes in the size of standard nozzles. In making up a nozzle of this type, it has been the practice to bore the circular nozzle for the particular class of locomotive on which it is to be tried, $\frac{1}{4}$ of an inch larger than the specified diameter. The projections are then made to give an area equal to the difference between specified and bored out areas. This method reduces the cost of applica-

tion to a minimum and does not necessitate the making of a new nozzle.

The purpose of the projections is to break up the continuity of the circular section of the exhaust jet and change it to a Maltese cross form, thereby increasing the gas entraining capacity of the jet and creating a greater vacuum in the front end. The nozzle is fastened to the exhaust stand without attention to the angular location of the projections relative to the axis of the front end as experiments have proved that alterations in this location do not affect the performance.

A number of tests were made in the locomotive testing plant at Altoona of both the standard circular nozzle and the internal projection nozzle on engines of three classes, in each case the only change made on the locomotives being the change in exhaust nozzles. These engines* were an Atlantic, E 6s, a Pacific, K 4s, and a Mikado, L 1s.

The following table gives a comparison of the maximum results which were obtained from the locomotives when using each

Type of locomotive	Atlantic		Pacific		Mikado	
	Four internal projections	Circular, 6.25 in. diameter	Four internal projections	Circular, 7 in. diameter	Four internal projections	Circular, 7 in. diameter
Kind of nozzle						
Area of nozzle, sq. in.	30.86	30.68	38.19	38.45	38.08	38.45
Speed, m. p. h.	46.9	47.0	47.3	37.8	28.3	29.3
Actual cut-off, in per cent.	52.0	46.0	60.3	46.4	60.8	51.1
Average boiler pressure, lb. per sq. in.	204.9	184.8	201.3	202.2	204.7	204.4
Draft in smokebox, in. of water	15.1	8.3	18.8	5.7	14.9	8.6
Draft in ashpan, in. of water	0.40	0.41	0.71	0.51	0.60	0.64
Dry coal fired per hr., lb.	8,271	6,942	11,813	5,146	9,312	6,621
Dry coal per sq. ft. grate	148.3	124.4	170.6	74.3	133.0	94.6
Water evap. per hr., lb.	44,628	35,928	65,400	39,977	59,508	46,170
Equiv. evap. per hr., lb.	58,641	46,771	87,414	51,842	79,675	58,539
Superheat, deg. Fahr.	204.2	175.9	215.2	157.2	183.5	122.2
Indicated horsepower	2,304.8	1,901.1	3,183.9	2,241.5	2,835.5	2,366.7

of the two nozzles. A wide open throttle was used in each instance and the working pressure of all the boilers was 205 lb. per square inch.

It will be observed that a much better performance in general was obtained from each of the locomotives when using the new type of nozzle, and especially is this true in the case of the Pacific and Mikado types of locomotives, both of which have boilers similar in design. The Pacific type locomotive delivered an equivalent evaporation of 87,414 lb. per hour and 3,183.9 indicated hp., with the four internal projection nozzle, while with the standard 7 in. circular nozzle it was possible to obtain but 51,842 lb. equivalent evaporation per hour and 2,241.5 indicated horsepower. The Mikado type locomotive, having smaller drivers and a longer stroke, developed 79,675 lb. equivalent evaporation per hour compared with 58,539 lb. obtained with the circular nozzle, and 2,835.5 indicated horsepower or an increase of 469 i. hp. above what was developed with the use of the 7 in. circular nozzle. Comparing the performance of the Atlantic type locomotive when equipped with each of the two nozzles, there was obtained with the four internal projection nozzle an increase in equivalent evaporation of 24.2 per cent and 14.6 per cent greater indicated horsepower.

The considerably higher front end draft obtained with the new type of nozzle in each instance, is responsible for the remarkable results attained, enabling the maintenance of a much greater rate of combustion and permitting a higher degree of superheat to be obtained.

LILLE'S LOCOMOTIVES.—Lille is one of the biggest engineering centers in France, and the work shops must have been of considerable use to the Germans. The great Fives-Lille works are well known for the construction of locomotives and bridges, and have supplied an enormous amount of the equipment that has been required for France's railway projects in her African colonies.

*For descriptions of these locomotives see the following numbers of the Railway Age Gazette, Mechanical Edition: E6s, page 63, February, 1914; K4s and L1s, page 343, July, 1914.

HEAVY DUTY ELECTRIC REAMER

A heavy duty reamer of a new design, for use on direct current circuits only, has been brought out by The Cincinnati Electrical Tool Company, Cincinnati, Ohio. It is designed for bridge work, large shop and construction work of all kinds, and is made in three sizes for reaming holes 15/16 in., 1 1/16 in. and 1 3/16 in. respectively.

The motor is of the series wound four pole type, and is completely enclosed. It is air-cooled by means of a fan mounted on the armature shaft. The housing and gear case is of steel, giving special strength and insuring the best of electrical performance. The gears are made of chrome nickel steel. They are mounted on roller bearings and are fully enclosed in the lower head of the reamer. They revolve in grease and are separated from the motor housing by means of a plate which prevents oil and grease from getting into the windings. High grade annular bearings are used on both ends of the armature

shaft. The spindle thrust is taken up by means of a thrust ball bearing.

The switch is of the quick make and break type, with release lever in one side handle. It is simple in construction and is guaranteed against overload. The brush holders are mounted on fiber blocks and are highly insulated. The binding posts

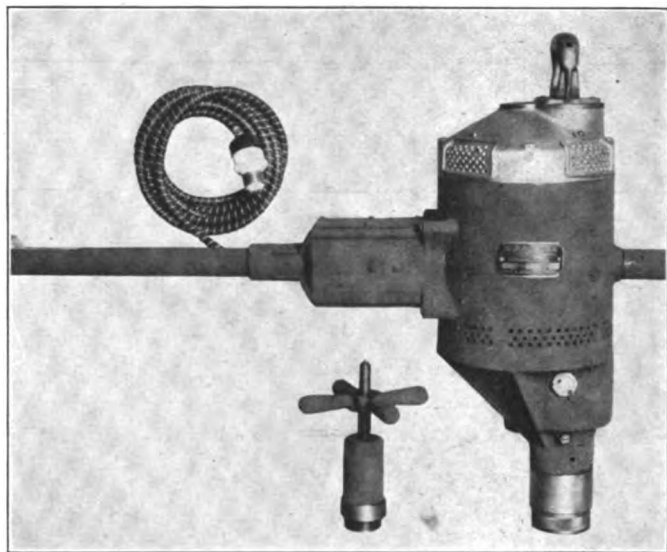

Electric Reamer for Heavy Work

which hold the leads are specially designed to secure contact by means of compression springs, doing away entirely with the use of nuts and screws, and preventing the latter from loosening and lodging in the motor. The brushes are readily accessible by means of four removable window guards and can be replaced instantly without removing the cap or disturbing any part of the machine.

The reamer is equipped with special type of slip socket which

does away with the drift key and drift holes in the spindle and prevents dirt and grease getting into it.

JOURNAL BOX PACKING GUARD

A packing guard for use in journal boxes, which holds the packing under the journal and prevents it from working out between the lid and the box has been placed on the market by the Nuway Packing Guard Company, Tuscaloosa, Ala. It

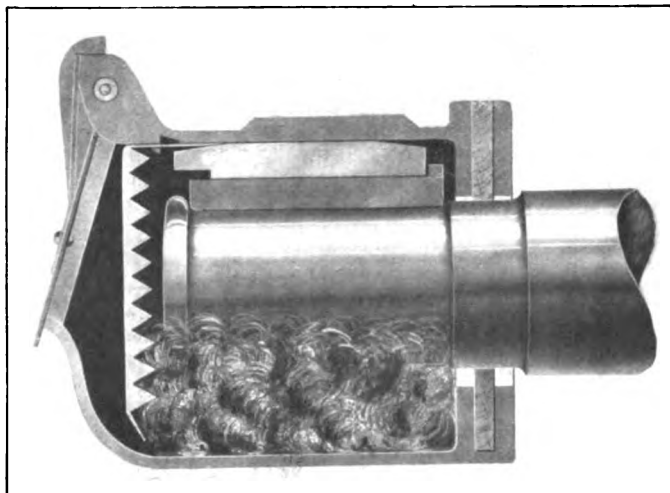

Packing Guard in Position in the Journal Box

is formed from No. 14 gage steel with teeth extending back from the sides and bottom. A tongue extends back from the top of the guard, by means of which it is secured in the

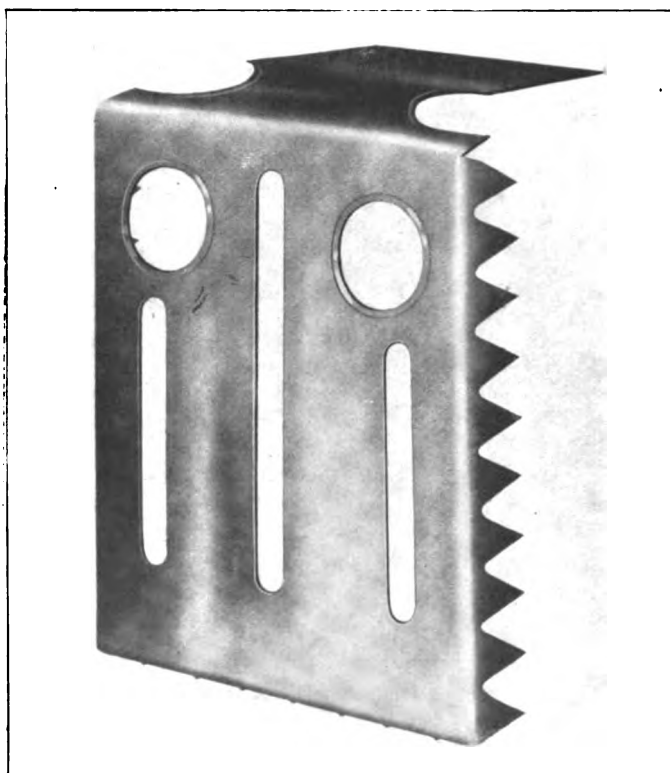

Packing Guard for Journal Boxes

journal box. In applying the guard the weight of the car is raised from the journal and the box packed, the packing being pushed well back against the dustguard and the box filled

only to the end of the journal. The guard is then placed in the box with the tongue, which is formed to fit the lugs at the top of the box, between the box and the wedge. When in position the weight of the car is let down on the journal, thus securely holding the guard in place. A small quantity of packing is then pushed around the sides of the guard. Holes are provided in the packing guard through which oil may be applied should the packing become dry. The guard is manufactured in different sizes and to fit the various types of journal boxes.

LOCOMOTIVE WEDGE BOLT

The wedge bolt shown in the drawing is designed to be applied and removed without the necessity of taking down the pedestal binder. The device, which is manufactured by the Wine Railway Appliance Company, Toledo, Ohio, is made standard for all wedges on the locomotive, and in case of emergency may be renewed by the engineer while the engine is in service on the road.

The pedestal brace is provided with a slot, as shown in the drawing, through which is inserted a tee headed sleeve. The wedge bolt is screwed into this sleeve, which in its normal position becomes a rigid part of the brace, and the bolt is operated in the same manner as if the sleeve were not used. The top of the pedestal brace is provided with a recess for the reception of

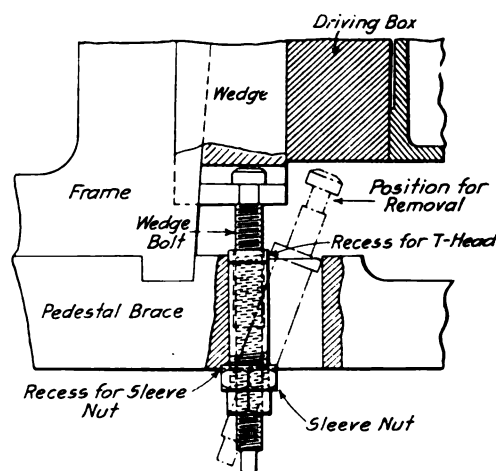

Wedge Bolt Removable While the Locomotive is in Service

the tee head and the bottom of the brace is provided with a recess for the reception of the sleeve nut, which is threaded on the sleeve. The wedge bolt is thus held rigidly within the pedestal brace.

It will be noted that the nut which locks the wedge bolt bears against the sleeve nut and acts as a lock nut for the sleeve as well.

To remove one of these bolts, all that is necessary is to back off the lock and sleeve nuts until the tee head on the sleeve can be lifted out of the recess on the top of the pedestal brace. The sleeve is then revolved through 90 deg. into the position shown by dotted lines, the head of the wedge bolt being slid out of the slot in the wedge at the same time. In order to do this the wedge must be drawn down into the position shown so that the slot in the wedge is clear beneath the driving box.

This device is in use on about 100 engines and is said to be giving excellent service.

EXPORT OF FORD MOTOR CARS.—The Ford Motor Company, Detroit, Mich., announces an order for 40,000 motor cars for shipment to one of the allied nations. It is the largest recorded single order for motor cars, and is said to involve \$16,000,000 to \$18,000,000.—Iron Age.

SINGLE LOCOMOTIVE WATER JOINT

The single water joint illustrated below has recently been developed by the Franklin Railway Supply Co., 30 Church street, New York. It eliminates the use of the present rubber hose connections for the injector suction pipes and provides one con-

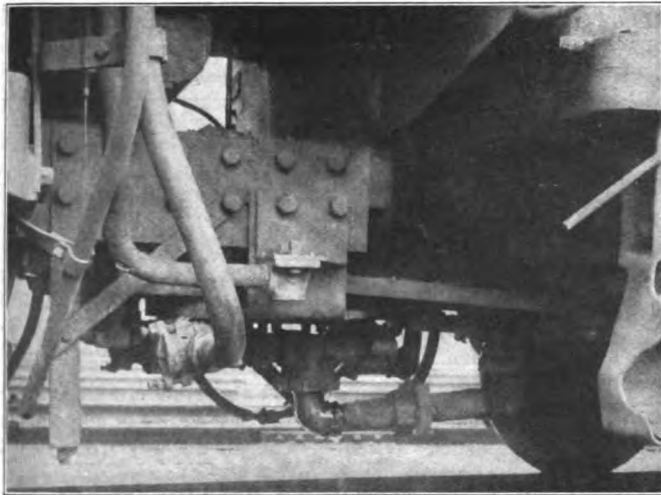

Location of the Single Water Joint Under the Drawbar

nection which is large enough to supply water to both injectors. It is located directly under the drawbar on the center line of the locomotive.

The water connection, which is made up of extra heavy wrought iron pipe, is attached at either end to tee heads, the branches of which lead to the two tank wells on the tender and

which is supported in a slide bearing bracket secured to the deck of the locomotive. This arrangement serves as a guide for the slip joint, relieving it from lateral strain.

All the attention this joint is said to require is the occasional renewal of the gasket in the ball and slip joints. One of the difficulties it is expected to overcome is freezing, which often occurs in the present hose connections. The probability of freezing in this connection is reduced owing to the fact that either heater will keep it open while both heaters are required with the usual type of double connection.

INDIAN WATER POWER SYSTEM.—On February 10 the governor of Bombay opened the Tata hydro-electric scheme, which ultimately will provide Bombay with electric energy equal to 130,000 hp., or five times the amount hitherto derived from water throughout India.—*The Engineer*.

CONVERTING BRITISH CARS.—Since 1911 the many passenger vehicles which have been added to the Great Eastern Railway Company's stock have all been mounted on two four-wheeled trucks, and no further carriages will be built to older designs. Many of the more modern of the non-bogie type, however, still possess substantial life, and a plan is being followed to convert these into bogie or four-wheel truck cars. The bodies of these vehicles are 27 ft. in length and, as the standard bogie underframe is 54 ft. long, two of them are placed together on one frame. One end of both bodies is stripped of panels and moldings and the overhanging roof boards are cut off level with the framework. The bodies are then placed on the underframe and butted and bolted together through the framework. The side joints are covered with a fascia molding and the roof joint is filled in and covered with raw canvas bedded in stiff paint. The combined bodies are secured to the underframe with body bolts in the ordinary way, whilst the usual stop blocks are placed at each

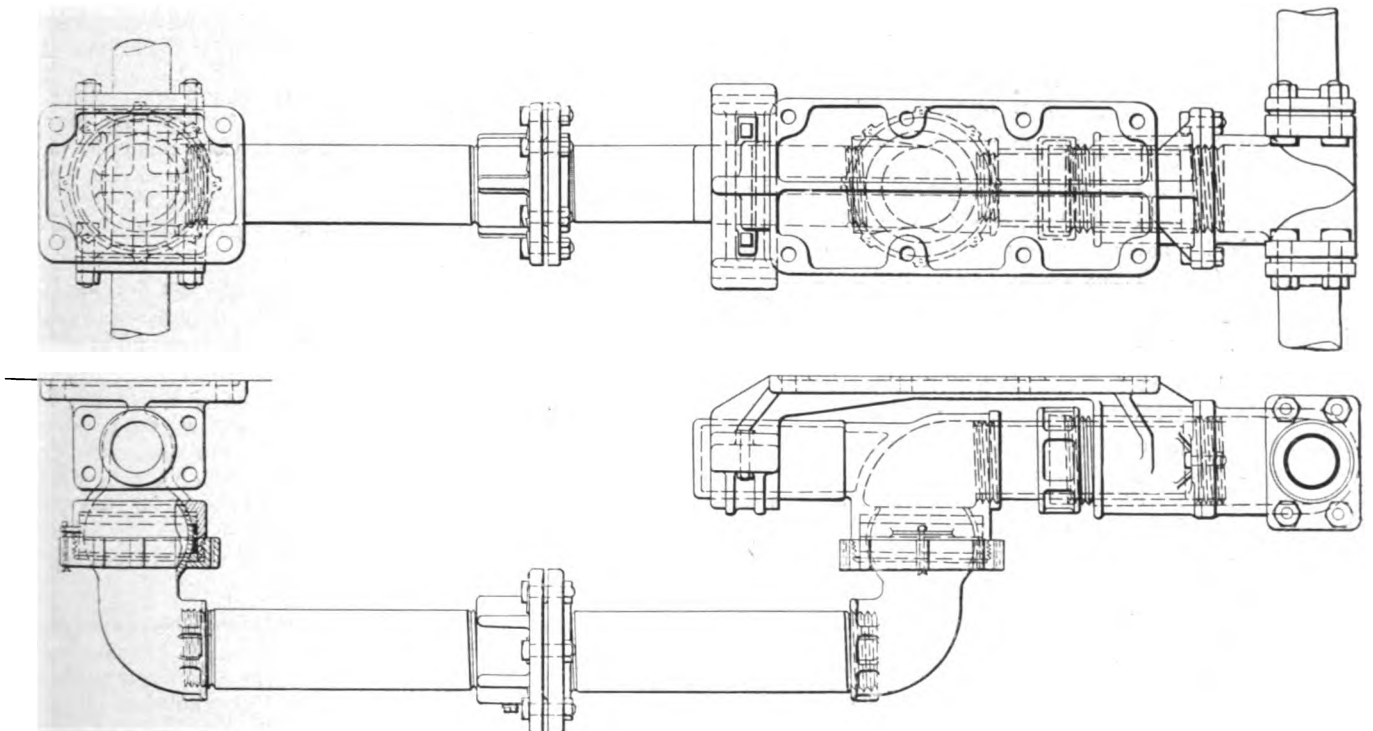

Single Water Joint for Use Between Engine and Tender

to the two injector suction pipes on the engine. It includes two ball joints and one slip joint, a combination which takes any motion occurring between the engine and tender. At its rear end the inside sleeve of the slip joint is threaded into an elbow connection which turns downward and forms the outer casing of the forward ball joint. An extension is cast on the elbow

end. It is rarely that a body has to be lifted from the underframe; but in case of such necessity the body would be divided where joined and lifted in two sections. Although this policy results in a decreased number of vehicles, the seating capacity is not diminished, and it is probable that some 500 carriages will be treated in this way.—*The Engineer*.

NEWS DEPARTMENT

On March 4 the roundhouse of the Cleveland, Cincinnati, Chicago & St. Louis at Benton Harbor, Mich., was destroyed by fire.

It is reported that the International & Great Northern is planning to completely electrify its shops at Palestine, Tex., at an approximate cost of \$25,000.

The Queen & Crescent Route has recently completed a new coach shop building at Chattanooga, Tenn., which will accommodate most of the coach repair work of the road. The building is 300 ft. by 106 ft., and was built by the road's own forces.

John G. Cooper, of Youngstown, Ohio, until lately a locomotive engineer on the lines of the Pennsylvania company, is now the representative in Congress from the Nineteenth Ohio district. He has served two terms in the Ohio legislature and has been a prominent worker in the anti-liquor campaign.

The "Safety First" committee of the Baltimore & Ohio reports that 91 per cent of all items recommended to improve safety conditions during 1914 were disposed of by the company. Recommendations totaling 9,256 items were made by 698 employees, who are members of safety committees on 23 divisions. Only 806 of the items reported remain under consideration.

J. E. Long, safety engineer of the Canadian Government Railways—the Intercolonial and the Prince Edward Island—reports that during the first year of his incumbency, January 1, 1914, to January 1, 1915, fatal injuries to employees have fallen off from 19, in 1913, to 7, in 1914; injuries have been reduced from 695 to 523, and the number of trespassers killed dropped from 22 to 13.

Aiming to protect its employees against permanent injury to the eye, the Baltimore & Ohio urges, in a circular issued recently, that in case of eye injury, or of foreign particles lodging in the eye, to secure the service of a company physician whenever possible. Railroad experience cites many cases of permanent injury to the eye or loss of sight as a result of inexperienced persons attempting to act in the capacity of surgeons.

The Canadian government, confronted with the continued refusal of the Grand Trunk Pacific to operate the National Transcontinental Railway, which extends 1,500 miles from Moncton, N. B., to Winnipeg, Man., announces that to prevent the destruction of the road bed and track by floods and frost, preparations are being made to organize forces to take care of the property, and, probably, to establish a regular train service.

The Russian government is negotiating with the New York Air Brake Company and the Westinghouse Air Brake Company for an order of 2,000,000 shrapnel. The Russian government has already established a credit in this country to meet payment for one-fourth of the order, which, it is said, will have a total value of \$36,000,000. The same government recently placed a large order for shrapnel with the Canadian Car & Foundry Company.

Governor Johnson of California has started a movement for the purchase of the Western Pacific, now in the hands of receivers, by the state of California. The governor is quoted as saying, "It is my idea that with California owning and operating a great transcontinental railroad the state will always be assured of commercial freedom." A memorial to Congress requesting it to take action toward the purchase of the road by the federal government has been introduced in both the House and Senate of the California legislature.

The Southern Railway has just put in service 57 steel passenger cars, all electric-lighted. These cars have been assigned to eight

of the most important through trains; and steel-frame cars heretofore used on these trains have been assigned to other through trains. This in turn has released steel underframe cars for use in local trains. Seven steel dining cars have recently been put in service.

Rule G, the well-known paragraph of the Standard Code of Train Rules prohibiting the use of intoxicating liquors, has been taken as the theme for a motion picture, based on Rufus Steele's story in the Saturday Evening Post. The film was staged in the yards and offices of the Southern Pacific Company at San Francisco, and the road placed all its facilities at the disposal of the camera men. Even the actors were selected from the ranks of the company's employees. This film is to be shown in numerous places along the Southern Pacific lines, and elsewhere.

The testing laboratory of the New York, New Haven & Hartford at New Haven, Conn., during the past year has made about 10,000 tests, the articles tested ranging all the way from pencils to piston rods and from milk to paint. Special attention has been given to sanitation on passenger trains, and the milk and cream for the dining cars have been kept at the highest standard. The physicists of the laboratory have made a large number of tests of air in passenger cars on trains, and a thorough system of sterilizing drinking water receptacles on trains has been established. The chemists have analyzed the water from each one of the wells on the company's premises.

Peter M. Hoffman, coroner of Cook county, Illinois, has addressed a circular letter to various clubs and organizations in the county giving statistics of railroad accidents and pointing out the large preponderance of accidents to trespassers on railroad property. He encloses a copy of a bill which is before the Illinois legislature to prohibit trespassing and urges efforts on the part of the organizations to secure its passage. He shows that in 1914 there were 282 people killed in Cook county by railroads or on railroad tracks. Of these 13 were passengers, 100 were employees and 169 were trespassers. For the 10 years, 1905 to 1914, his records show that 80 passengers, 1,309 employees and 1,922 trespassers were killed.

The Pennsylvania Railroad reports that 427 fires—more than three-quarters of all that occurred on the property of the system last year—were extinguished by company employees before receiving the aid of public fire departments. The average loss was \$43. Organized fire brigades among the employees last year checked 34 fires, and other employees, by the use of chemical extinguishers, put out 71. The total fire loss on the Pennsylvania system during the year 1914, including fires where the assistance of city fire departments was received, was \$658,483, while the value of the entire property was nearly \$400,000,000, the fire loss being only 16 cents per each \$100 of property value at risk.

The safety department of the Delaware, Lackawanna & Western has issued Safety First Bulletin No. 10, giving a summary of accidents to Lackawanna employees for the years 1911, 1912, 1913 and 1914. The number of employees killed in 1911 was 70, and in 1912, 46; 1913, 45, and in 1914, only 26. The number of employees injured in 1911 was 2,319; in 1912, 2,318; in 1913, 2,092, and in 1914, 1,875. There has thus been a steady decrease year by year. Comparing 1914 with 1911, the decrease in the number of employees killed was 63 per cent, while the injured decreased 19 per cent. It has been decided to award a Safety First flag to the division making the best safety record in 1914, and subsequent years, and also one to the shop making the best record. For the year 1914, the Morris & Essex division was

awarded the division flag and the Scranton-Keyser Valley shops were awarded the shop flag.

Congress, in making appropriations for the support of the army for the next fiscal year, has inserted in the law a proviso that no part of the appropriations made at this time shall be available "for the salary or pay of any officer, manager, superintendent, foreman or other person having charge of the work of any employee of the United States government while making or causing to be made, with a stop watch or other time-measuring device, a time study of any job of any such employee between the starting and completion thereof, or of the movements of any such employee while engaged upon such work; nor shall any part of the appropriations made in this bill be available to pay any premium or bonus or cash reward to any employee in addition to his regular wages, except for suggestions resulting in improvements or economy in the operation of any government plant; and no claim for services performed by any person while violating this proviso shall be allowed."

One of the striking exhibits at the Panama-Pacific Exposition is that of the Westinghouse Electric & Mfg. Company, which includes one of the Pennsylvania electric locomotives mounted on a turntable. The location of the turntable is under the center of the dome of the Transportation building at the junction of the two main aisles, thus bringing it in full view of the crowds which are expected to pass through this building. The turntable is 65 feet long, and, including the locomotive, weighs 440,000 pounds. The height of the track is 12 ft. above the floor, and steel ties are used, a new type of construction for this class of work. By means of a 10-horsepower motor the turntable is caused to rotate at a speed of one revolution in three minutes. The rotation, which can be reversed in direction, is under the control of the operator located in a booth nearby. The locomotive is arranged and lighted so as to permit the people to pass through it and inspect the equipment.

Commissioner Mayfield of the Texas Railroad Commission has sent a telegram to J. W. Everman, general superintendent of the St. Louis Southwestern of Texas, protesting against the recent closing of the company's shops at Tyler, Tex., which threw out of employment some 300 or 400 men. The commissioner says in his telegram that the company's business is better than it has been for some time, requiring, as he is advised, "an extra switch engine to adequately handle the traffic," and that the road should be getting its equipment in condition to handle the large business expected this spring and summer. He says that unless the shops at Tyler are reopened and the men put back to work he will consider it his duty to move that the commission suspend further action on the application for an increase in freight rates pending investigation into the reason why the shops were closed. Mr. Everman said it was found absolutely necessary to close the shops at Tyler because of the decrease in earnings.

M. A. Dow, general safety agent of the New York Central Lines, is sending out to manufacturers owning plants adjacent to the company's property small printed slips on "safety first," to be put into the pay envelopes of employees. The statement

begins by saying that the railroad company has called the manufacturers' attention to the risk incurred by the employees of the factory who walk on the tracks; and, after briefly explaining the general situation, it ends with the injunction that "the practice of walking the railroad tracks by our employees must be stopped at once. The interests of personal safety require that strict observance of this rule must be enforced." Mr. Dow furnishes the slips printed in English and other languages, as may be needed. Within a reasonable time after the notices have been supplied to a given factory, the inspectors of the railroad company make observations to see how well the advice has been carried out; and if track walking continues officers are sent to make some arrests.

NEW RAILROAD LAWS IN TEXAS

The legislature of Texas has concluded its session of two months and a final review shows that it has passed only a few general laws affecting railroads. The most important, perhaps, is that requiring employees to be paid twice a month. Another one provides that employees of railroads (and of certain other concerns as well) shall be free to choose the company from which they shall get surety bonds. The railroads now provide bonds without cost to the employee.

The railroad commission is authorized, by one of the new laws, to require railroads to make track connections with industries.

There was a full-crew law, but it died on the calendar as did the bill to require sheds to be built at all points where there are ten or more car repairers at work.

On the whole it appears to many careful observers that the anti-railroad spirit among the Texas law makers is very much abated.

MEETINGS AND CONVENTIONS

Chief Interchange Car Inspectors' and Car Foremen's Association.—At a recent meeting of the executive committee of the Chief Interchange Car Inspectors' and Car Foremen's Association, which was held in Chicago, it was decided to hold the next annual convention of the association in Richmond, Va., September 14, 15 and 16.

Air Brake Association.—The twenty-second annual convention of the Air Brake Association will be held at the Hotel Sherman, Chicago, on May 4-7, 1915. The following is a list of the subjects to be discussed at the meeting: Accumulation of Moisture and Its Elimination From Trains and Yard Testing Plants; Adequate Hand Brakes on Heavy Passenger Equipment Cars; Need of Efficient Cleaning and Repairing of Freight Brakes; What Shall We Do to Improve the Present Pneumatic Signal Device; Difficulties the Railroad Companies Encounter in Endeavoring to Run 100 Per Cent Operative Brakes in Freight Train Service; M. C. B. Air Brake Hose Specification and Recommended Practice. The afternoon of May 6 has been set aside for a series of air brake lectures, delivered by representatives of the Pittsburgh Air Brake Company, Westinghouse Air

RAILROAD CLUB MEETINGS

Club	Next Meeting	Title of Paper	Author	Secretary	Address
Canadian	April 13	Systematic Locomotive Valve Setting	J. R. Britton	James Powell	St. Lambert, Que.
Central	May 9			Harry D. Vought	95 Liberty St., New York.
New England	April 13	Economical Handling of Freight Cars	W. C. Kendall	Wm. Cade, Jr.	683 Atlantic Ave., Boston, Mass.
New York	April 16	Recent Developments in Locomotives	George R. Henderson	Harry D. Vought	95 Liberty St., New York.
Pittsburgh	April 23			J. B. Anderson	207 Penn. Station, Pittsburgh, Pa.
Richmond	April 12	Chilled Iron vs. Steel Wheels	F. K. Vial	F. O. Robinson	C. & O. Ry., Richmond, Va.
St. Louis	April 9	Encouraging Railroad Men to Buy Homes	H. M. Cottrell	B. W. Frauenthal	Union Station, St. Louis, Mo.
South'n & S'w'rn	May 20			A. J. Merrill	Box 1205, Atlanta, Ga.
Western	April 20			Jos. W. Taylor	1112 Karpen Bldg., Chicago, Ill.
Western Canada				Louis Kon	Box 1707, Winnipeg, Man.

Brake Company, New York Air Brake Company, and possibly the Automatic Straight Air System, each speaker being limited to one hour. The practice inaugurated at the last convention of giving one afternoon to the representatives of the manufacturers for the exploitation of their devices will again be followed this year, and May 4 is the date which has been assigned for the purpose.

Master Car and Locomotive Painters' Association.—The Advisory Committee of the Master Car and Locomotive Painters' Association has selected the following subjects and queries to be considered at the next convention, which will be held at Detroit, Mich., September 14 to 16: Subject No. 1, Flat color v. enamel color—which gives the best results under varnish in durability and permanency of color? No. 2, Can we suggest any changes in the design or construction of steel passenger train cars to make them better fitted for preservation by protective coatings? No. 3, Will equipment finished in enamel or varnish color wear and "clean up" in service as easily and economically as the varnish finish? No. 4, Best methods of taking care of piece-work accounts, including rate fixing, printed forms, clerical organization, etc., for work in paint shops. No. 5, What is the most practical and economical method of maintaining the inside of steel passenger cars? Essay No. 1: The possible results, where price vs. quality is enforced in buying paint stock for the railway car and locomotive paint shop. No. 2: The official recognition due to the efficient railway master car and locomotive painter. Query No. 1: Are we having any serious trouble with varnish turning white and if so, with what grade of varnish? No. 2: Is there any way by which a greater field of the work of the association can be covered, without increasing the time consumed in handling the work? No. 3: Of what value to the railway companies is ornamentation to the exterior of railway passenger equipment?

The following list gives names of secretaries, dates of next or regular meetings, and places of meeting of mechanical associations.

- AIR BRAKE ASSOCIATION.**—F. M. Nellis, 53 State St., Boston, Mass. Convention, May 4-7, 1915, Hotel Sherman, Chicago.
- AMERICAN RAILROAD MASTER TINNERS, COPPERSMITHS AND PIPEFITTERS' ASSOCIATION.**—W. E. Jones, C. & N. W., 3814 Fulton street, Chicago. Annual meeting, July 13-16, 1915, Hotel Sherman, Chicago.
- AMERICAN RAILWAY MASTER MECHANICS' ASSOCIATION.**—J. W. Taylor, Karpen building, Chicago. Convention, June 9-11, 1915, Atlantic City, N. J.
- AMERICAN RAILWAY TOOL FOREMEN'S ASSOCIATION.**—Owen D. Kinsey, Illinois Central, Chicago. Convention, July 19-21, 1915, Hotel Sherman, Chicago.
- AMERICAN SOCIETY FOR TESTING MATERIALS.**—Prof. E. Marburg, University of Pennsylvania, Philadelphia, Pa. Convention, June 22-26, 1915, Hotel Traymore, Atlantic City, N. J.
- AMERICAN SOCIETY OF MECHANICAL ENGINEERS.**—Calvin W. Rice, 29 W. Thirty-ninth street, New York. Annual meeting, December 7-10, 1915, New York.
- ASSOCIATION OF RAILWAY ELECTRICAL ENGINEERS.**—Joseph A. Andreucetti, C. & N. W., Room 411, C. & N. W. Sta., Chicago. Annual meeting, October, 1915.
- CAR FOREMEN'S ASSOCIATION OF CHICAGO.**—Aaron Kline, 841 North Fifthth Court, Chicago; 2d Monday in month, except July and August, Lytton building, Chicago.
- CHIEF INTERCHANGE CAR INSPECTORS' AND CAR FOREMEN'S ASSOCIATION.**—S. Skidmore, 946 Richmond street, Cincinnati, Ohio. Annual meeting, September 14-16, 1915, Richmond, Va.
- INTERNATIONAL RAILWAY FUEL ASSOCIATION.**—C. G. Hall, 922 McCormick building, Chicago. Convention, May 17-20, 1915, Chicago.
- INTERNATIONAL RAILWAY GENERAL FOREMEN'S ASSOCIATION.**—William Hall, 1126 W. Broadway, Winona, Minn. Convention, July 13-16, 1915, Hotel Sherman, Chicago.
- INTERNATIONAL RAILROAD MASTER BLACKSMITHS' ASSOCIATION.**—A. L. Woodworth, Lima, Ohio. Convention, August 17, 1915, Philadelphia, Pa.
- MASTER BOILER MAKERS' ASSOCIATION.**—Harry D. Vought, 95 Liberty street, New York. Convention, May 26-28, 1915, Chicago, Ill.
- MASTER CAR BUILDERS' ASSOCIATION.**—J. W. Taylor, Karpen building, Chicago. Convention, June 14-16, 1915, Atlantic City, N. J.
- MASTER CAR AND LOCOMOTIVE PAINTERS' ASSOC. OF U. S. AND CANADA.**—A. P. Dane, B. & M., Reading, Mass. Convention, September 14-17, 1915, Detroit, Mich.
- NIAGARA FRONTIER CAR MEN'S ASSOCIATION.**—E. Frankenberger, 623 Brisbane building, Buffalo, N. Y. Meetings monthly.
- RAILWAY STOREKEEPERS' ASSOCIATION.**—J. P. Murphy, Box C, Collinwood, Ohio. Convention, May 17-19, 1915, Hotel Sherman, Chicago.
- TRAVELING ENGINEERS' ASSOCIATION.**—W. O. Thompson, N. Y. C. & H. R., East Buffalo, N. Y. Convention, September, 1915, Chicago, Ill.

PERSONALS

It is our desire to make these columns cover as completely as possible all the changes that take place in the mechanical departments of the railways of this country, and we shall greatly appreciate any assistance that our readers may give us in helping to bring this about.

MASTER MECHANICS AND ROAD FOREMEN OF ENGINES

G. P. GOODRICH, who has been master mechanic of the Fort Smith & Western and the St. Louis, El Reno & Western for the last eight years, has resigned, effective April 1.

J. W. JOHNSON has been appointed master mechanic of the Arkansas, Louisiana & Gulf, with office at Monroe, La., succeeding J. T. Tadlock.

A. E. McMILLAN, whose appointment as master mechanic of the Baltimore & Ohio Southwestern, at Washington, Ind., was announced in these columns last month, was born in Wheeling, W. Va., December 26, 1880. He received his education in the public schools of that city, graduating from the high school in 1898. Early in 1899 he entered the service of the Baltimore & Ohio at Benwood, W. Va., as a machinist apprentice, and on completing his apprenticeship he served as a machinist at the same point. In 1905 he was made machine shop foreman, serving in this capacity and as drop pit foreman until September, 1907. He was then appointed engine house foreman, and in April, 1910, became general foreman at Beawood. Early in 1913 he was transferred to the Baltimore & Ohio Southwestern system as motive power inspector, with headquarters at Cincinnati, Ohio, and a year later was appointed assistant master mechanic, in which capacity he served until his recent appointment as master mechanic.

R. J. MCQUADE has been appointed master mechanic of the St. Louis & Kansas City Terminal division of the Rock Island Lines, with office at Armourdale, Kan., succeeding O. C. Breisch, resigned.

A. YOUNG, whose appointment as district master mechanic of the Chicago, Milwaukee & St. Paul, at Milwaukee, Wis., was announced in these columns last month, was born January 24, 1874. After graduating from the public schools in Milwaukee he was employed in the foundry of the Chicago, Milwaukee & St. Paul for one year, and then transferred to the machine shop as a machinist apprentice. After completing his apprenticeship, Mr. Young remained in the employ of the St. Paul, serving as a machinist at various points until 1898, when he left the service to become an engineer in the Milwaukee city fire department. In the spring of 1902 he left the fire department to again enter the St. Paul service as a machinist in the Milwaukee shops, where he remained until 1905. He was then transferred to the roundhouse at the West Milwaukee shops, where he served successively as slip foreman, assistant foreman and general roundhouse fore-



A. Young

man, being promoted to the latter position in 1909. In July, 1913, Mr. Young was transferred to Chicago as general foreman at that point, in which capacity he served until his recent appointment as district master mechanic. Mr. Young is a graduate of the International Correspondence School.

W. L. SCOTT has been appointed master mechanic of the Missouri, Kansas & Texas at Denison, Tex., succeeding N. S. Airhart, resigned.

CAR DEPARTMENT

A. COPONY, master car builder of the western lines of the Grand Trunk, has had his office moved from Port Huron, Mich., to Elsdon, Ill.

V. J. LAMB, car foreman of the Charleston & Western Carolina, at Augusta, Ga., has been appointed general foreman car repairs at that place, succeeding W. F. Weigman.

T. W. MARSHALL has been appointed assistant car foreman of the Canadian Pacific at Transcona, Man., succeeding H. Dibley.

SHOP AND ENGINE HOUSE

A. BEARDSHAW has been appointed locomotive foreman of the Grand Trunk at Richmond, Que., succeeding G. Blackbird, retired on a pension.

W. C. BUREL, district foreman of the Oregon Short Line at Montpelier, Idaho, has been appointed general foreman of the Utah district, Utah-Montana division, at Salt Lake City, Utah, succeeding H. Selfridge.

R. A. MILLER has been appointed general foreman of the Canadian Northern at Trenton, Ont., succeeding W. G. Rodden.

W. R. PATTERSON has been appointed general foreman of shops of the Michigan Central at Detroit, Mich., succeeding A. K. Galloway.

D. ROSS, formerly locomotive foreman at the Southwark Terminal of the Grand Trunk at Montreal, has been appointed locomotive foreman at Durand, Mich.

C. E. STEWART has been appointed locomotive foreman of the Grand Trunk Pacific at Edmonton, Alta.

CHARLES D. WILDER has been appointed boiler foreman of the Staten Island lines of the Baltimore & Ohio, at Clifton, Staten Island.

JOHN E. WOODS has been appointed general foreman of the Staten Island lines of the Baltimore & Ohio, at Clifton, Staten Island.

R. R. YOUNG has been appointed general foreman of the shops of the Tennessee Central at Nashville, Tenn.

PURCHASING AND STOREKEEPING

FRANK DUNBAR has been appointed storekeeper of the Intercolonial at Gibson, N. B.

JOHN O'BRIEN has been appointed storekeeper of the Canadian Pacific at Regina, Sask.

OBITUARY

CHARLES McCANN, general foreman of the Chicago Junction Railway, died in Chicago, March 6, at the age of 65 years. Mr. McCann began railway work on the Atlantic & Great Western at Kent, Ohio, in 1867. He was later employed by the Lake Shore & Michigan Southern at Norwalk, Ohio, and the New York, Chicago & St. Louis, during the construction of this road between Conneaut, Ohio, and Ft. Wayne, Ind. In 1897 he left the latter road to enter the service of the Chicago Junction Railway, with which he remained until his death.

JOHN W. ADDIS, formerly superintendent of motive power of the Texas & Pacific, died at Marshall, Tex., on February 25. He was born on March 13, 1851, at East Liberty, Pa., and after learning the trade of machinist entered the shops of the International & Great Northern, at Palestine, Tex. In 1882 he went to the Marshall shops of the Texas & Pacific, and left that road to become general foreman at the Tyler shops of the St. Louis Southwestern. He was transferred later to the Pine Bluff shops, of which he had charge, and was then for about four years master mechanic at the Gouldsboro shops of the Texas & Pacific. About 1892 Mr. Addis succeeded A. G. Douglass as superintendent of motive power and rolling stock of the Texas & Pacific at Marshall, and remained in the service of that road until June, 1911.

WILLIAM McINTOSH, formerly superintendent of motive power of the Central of New Jersey, at Jersey City, N. J., died on March 15, at his home in Plainfield, N. J. He was born on August 20, 1849, at Franklin, Que., and began railway work in 1864 as a locomotive fireman on the Chicago, Milwaukee & St. Paul; and he served as machinist and engineer on that road for seven years. In 1871 he went to the St. Paul & Pacific, now a part of the Great Northern, at St. Paul, Minn., where he was employed as machinist. From August, 1872, to November, 1877, he was locomotive engineer on the Chicago & North Western and then for about ten years was foreman of locomotive repairs on the same road at Waseca, Minn., and



W. McIntosh

at Huron, S. D. In July, 1887, he was appointed master mechanic at Winona, Minn., where he remained about 12 years. On March 1, 1899, he was appointed superintendent of motive power of the Central of New Jersey, from which position he retired in 1909. He was a prominent member of the American Railway Master Mechanics' Association, and in 1908 served as president of that association. Mr. McIntosh was the inventor of a number of well known locomotive and car appliances. He was a member of the American Society of Mechanical Engineers.

EXHAUST STEAM INJECTORS FOR LOCOMOTIVES.—The exhaust steam injector has found quite extensive use on British locomotives, and from what information can be obtained it is believed to be one of the small economy producers that are worthy of consideration. From its extended use it can no longer be considered experimental. The exhaust steam is taken from the exhaust pipe just above the outlet from the cylinders. It then passes through a separator which removes all the grease and particles of dirt, and then goes direct to the injector. Live steam is used to start the injector. This may be entirely shut off after the exhaust steam has been started, or a small amount can be admitted to assist in pumping against a high boiler pressure. When the engine is not working provision is made for operating the injector by live steam alone. From tests made in England it is found that an average saving of 700 to 1,000 lb. of coal and about 4,000 lb. of water per 100 miles is obtained. For boiler pressures in the neighborhood of 200 lb. it is necessary to supplement by the use of a small amount of live steam, the exhaust steam at atmospheric pressure being capable of delivering against 120 lb. boiler pressure.

SUPPLY TRADE NOTES

Frederick A. Hall, formerly head of the chain hoist department of the Yale & Towne Company, died at his home in Passaic, N. J., on March 16.

J. W. Fogg, formerly master mechanic of the Baltimore & Ohio Chicago terminal, has become associated with the Boss Nut Company, with headquarters at Chicago.

A. D. McAdam, formerly western sales agent of the Ralston Steel Car Company, Columbus, Ohio, has been appointed sales manager, with headquarters at Columbus.

G. Haven Peabody, western representative of the Lima Locomotive Corporation, Lima, Ohio, has resigned, effective April 15, to accept a position with the Lackawanna Steel Company.

W. C. Chapman, who for several years has been connected with the sales force of the Philadelphia branch office of Manning, Maxwell & Moore, Inc., has been appointed manager of that office.

Robert E. Jennings, president of the Carpenter Steel Company, Reading, Pa., has been elected to fill the vacancy on the board of the Joseph Dixon Crucible Company, Jersey City, N. J., caused by the death of William Murray.

W. W. Rosser, manager of western sales of the T. H. Symington Company, Rochester, N. Y., has been appointed vice-president of the company, with office at Chicago. Mr. Rosser was born at Hutchinson, Minn., on November 4, 1877. He attended the Hamline University at St. Paul, Minn., and was for four years with the Minnesota Malleable Iron Company. In 1903 he left the company to take the position of superintendent of the Washburn Coupler Company, and two years later became sales agent of the T. H. Symington Company at Chicago. In 1910 he was appointed manager of western sales of that company, and now leaves that position to take up the duties of vice-president, as above noted.



W. W. Rosser

E. L. Leeds, who since 1907 has been manager of the railroad equipment department of the Niles-Bement-Pond Company, New York, has been appointed general manager of sales of that company and the Pratt & Whitney Company, Hartford, Conn.

The Superior Car Metal Roofing Company, Chicago, Ill., has recently been incorporated for \$25,000 for the purpose of manufacturing and selling car roofs, doors, locks, etc. The incorporators are William H. Slatten, William F. Nolan and E. A. Albright.

The Stark Rolling Mill Company, Canton, Ohio, has appointed the Dearborn Steel & Iron Company, with offices in the Peoples Gas building, Chicago, Ill., as its selling agent in Chicago, northern Illinois and Wisconsin. H. C. Perrine and E. L. Lyon will represent the company.

The Sprague Electric Works of the General Electric Company, New York, has opened a branch sales office in the Illuminating building, Cleveland, Ohio, and Frank H. Hill, who also

has charge of the Pittsburgh office, has been appointed manager of the Cleveland office.

The Locomotive Pulverized Fuel Company has obtained a charter in Delaware to manufacture patented fuel saving devices. The incorporators are Joel S. Coffin, Englewood, N. J.; John E. Muhlfeld, Scarsdale, N. Y.; H. F. Ball and Samuel G. Allen, New York, and LeGrand Parish, Mountain View, N. J.

Walter C. Allen, vice-president and general manager of the Yale & Towne Manufacturing Company has been elected president and general manager to succeed Henry R. Towne, who has been elected chairman of the board. Mr. Allen has been in the service of the company for 23 years. He entered the works in 1892 as a truck boy and two years later obtained a position in the office. He then spent three years acquiring the tool trade, and three more to obtain a knowledge of drafting, both of which he thought were essential to his advancement with the company. He was later made assistant to the general superintendent in the works at Stamford, and then became general superintendent. In 1909 he was appointed general manager of the company at New York, and in 1914 became vice-president and general manager. Mr. Allen is a member of the American Society of Mechanical Engineers.



W. C. Allen

Frederick Winslow Taylor, originator of the modern scientific management movement, died suddenly in Philadelphia on March 21 from pneumonia. Mr. Taylor was born at Germantown, Pa., on March 20, 1856. He attended Phillips Exeter Academy, but left before completing the course, because of impaired eyesight. In 1883, however, he graduated from Stevens Institute of Technology with the degree of Mechanical Engineer. In 1878 he entered the employ of the Midvale Steel Company, with which company he was successively gang boss, assistant foreman, foreman of the machine shop, master mechanic, chief draftsman and chief engineer. He left the company in 1889 and began his special work of reorganizing the management of manufacturing establishments. Mr. Taylor was an inventor of considerable ability. Among his numerous inventions was the Taylor-White process of treating modern high-speed tools, for which he received a personal gold medal from the Paris Exposition in 1900 and the Elliott Cresson medal of the Franklin Institute. Mr. Taylor was a member of the American Society of Mechanical Engineers, and



F. W. Taylor

served as its president in 1905 and 1906. He was the author of a number of technical books and articles, among the best known being "The Principles of Scientific Management" and "Shop Management," both published in 1911.

Henry H. Sessions, vice-president of the Standard Coupler Company of New York, died at his residence in Chicago, on March 14. Mr. Sessions was born in Madrid, N. Y., on June 21, 1847. He entered railway service on March 1, 1862, and until January 1, 1870, he served as apprentice and journeyman in the car and machine shops of the Central Vermont at Northfield, Vt. From January 1, 1870, to November 1, 1878, he was master car builder of the Rome, Watertown & Ogdensburg, and from then to April 1, 1880, for the Sioux City & St. Paul, now a part of the Omaha. On April 1, 1880, he was made master car builder of the International & Great Northern, and on May 10, 1881, and September



H. H. Sessions

1, 1882, he was appointed to similar positions with the Texas & Pacific and the St. Louis, Iron Mountain & Southern, respectively. In 1885 he was made manager of the Pullman Car Works. This position he held until 1892, and for four years he was chief mechanical engineer in an advisory capacity for the same company. During this time he invented the passenger car vestibule, and later designed the standard steel platform for passenger cars which went into general use at once. This led to his becoming associated with the Standard Coupler Company as vice-president and director in 1896. Mr. Sessions also designed the Sessions friction draft gear and in the course of his active life left a strong impression of his inventive genius on railroad operations in many ways.

On March 22 the Chicago office of the Terry Steam Turbine Company, Hartford, Conn., was placed in charge of A. W. de Revere, and located in the Peoples Gas building. The company has also opened an office in the Michigan Trust building, Grand Rapids, Mich., in charge of A. L. Searles, who will cover the southern peninsula of Michigan.

Joseph Mohr, president of John Mohr & Sons, boiler manufacturers of Chicago, Ill., died at his home on March 2, 1915. Mr. Mohr was born in Chicago in 1855, and, after serving an apprenticeship as boilermaker, he engaged in business with his father in 1882, under the firm name of John Mohr & Son, which was later changed to John Mohr & Sons.

The Southwark Foundry & Machine Company, Philadelphia, Pa., has secured the exclusive United States license to manufacture the Harris Valveless Engine. Diesel principle, which will hereafter be known as the Southwark-Harris Valveless Engine. The engine will be built in sizes from 75 B. H. P. to 1,000 B. H. P., for both marine and stationary service. With the company there will be associated as consulting engineer and naval architect Leonard B. Harris, the inventor of the Harris valveless engine, so that the company will have the benefit of his extensive experience in power engineering, especially in the marine field. J. P. Johnston, who has been interested in and connected with the Harris valveless engine, will also be associated with the company in charge of oil engine sales. The

Southwark Foundry & Machine Company also manufactures a full line of steam turbines, generators, turbine pumps, hydraulic pumps and presses, condensers, etc.

Two suits by the Safety Car Heating & Lighting Company, New York, against the United States Light & Heating Company, Niagara Falls, N. Y., have recently been decided in favor of the defendant by Judge Hazel in the Western District of New York. These suits were on the W. I. Thompson Patent No. 881,743, March 10, 1908, on a dynamo suspension for car lighting, and W. I. Thompson Patent No. 926,518, June 29, 1909, on a lighting system commonly referred to as the carbon disk regulator. In each case the patent was held invalid and the bill of complaint dismissed. The court held that the predecessors of the United States Light & Heating Company had installed dynamo suspensions and the carbon disk regulator substantially as described and claimed in the patents, on their own apparatus on the New York Central prior to the dates of the patents.

Henry R. Towne, president of the Yale & Towne Manufacturing Company, New York, for 46 years, having signified his desire to retire from the duties of that office, has been elected chairman of the board. Mr. Towne was born in Philadelphia, Pa., August 28, 1844. He attended the University of Pennsylvania, but he left before graduation to enter business, receiving, however, the honorary degree of M. A., in 1887. He was first employed as a mechanical draftsman in the Port Richmond Iron Works at Philadelphia. In 1866 he made an extensive tour of the leading engineering establishments in England, Belgium and France, spending six months in Paris, where he studied at the Sorbonne. Upon his return he worked for



Henry R. Towne

some time in the shops of William Sellers & Co., Philadelphia. In October, 1868, he formed a partnership with Linus Yale, Jr., and the Yale Lock Manufacturing Company was established at Stamford, Conn. Mr. Yale died shortly after, and in 1869 Mr. Towne became the president of the company, which at that time had a factory with 30 employees at Stamford and a salesroom in New York. To sketch Mr. Towne's career from that time is to sketch the growth of his company. At first it made bank locks and the Yale pin-tumbler locks. Later there were added safe deposit locks, mortise locks, the Yale time lock, etc. The company also had an important business in complete post office "equipments." In 1873 it added a bronze department, and in 1882 it established an art department. The company secured the American rights for the Weston differential pulley block. It was also one of the first, if not the first, in America, to build cranes, but the crane business was later sold to the Brown Hoisting Machinery Company, Cleveland, Ohio. It being felt that the name Yale Lock Manufacturing Company was not sufficiently inclusive, the title was changed in 1883 to the Yale & Towne Manufacturing Company. The company took many steps to broaden its activities. In 1878 it absorbed the United States Lock Company and the American Lock Company; in 1894 the Branford Lock Works, and in 1895 the Blount Manufacturing Company, in each case adding new lines. Mr. Towne has been an active member of the American Society of Mechanical Engineers for many years and served as its president.

CATALOGS

ELECTRIC DRILLS.—Bulletin E-35 has recently been issued by the Chicago Pneumatic Tool Company. It is devoted to electric portable drills which are designed for operation on direct or alternating current.

PREVENTION OF BELT SLIPPING.—The Gripwell Pulley Covering Company, 601 Candler building, New York, has just issued a folder devoted to its product "Gripwell," which is a cement and canvas covering for pulley surfaces designed to increase the adhesion of the belt.

PIPE BENDER.—Bulletin No. 5,001 of the Hydraulic Press Manufacturing Company, Mount Gilead, Ohio, is a folder entitled Bending Pipe with Hydraulic Power. It deals with a recently developed hand operated pipe bender manufactured by this company, having a pressure capacity of 30 tons.

STEAM TRAP.—Catalog No. 8 of the Automatic Steam Trap & Specialty Company, Detroit, Mich., is devoted to the Barton expansion automatic steam trap which is manufactured by this company. In addition to the price list the catalog contains a number of illustrations of traps in service and a number of testimonials from users of the device.

THREADING TOOLS.—The Oster Manufacturing Company, Cleveland, Ohio, has recently brought out its list No. 28 of Oster threading tools. This is a 64 page catalog containing illustrations and price lists of die stocks, light hand machines, screw plates, recutting dies and power machines. The operation of several types of Oster die stocks is described.

COAL DRIER.—Bulletin No. 212 of the Link-Belt Company, Chicago, describes the Wendell continuous automatic coal drier which is designed to dry washed coal for coking purposes and the smaller sizes of steam and domestic coal. The booklet is a four-page folder and contains a number of illustrations, among which is a diagram showing the method of operating the machine.

GRAPHIC METHODS.—The Statistics Bureau, 5 East Forty-second street, New York, has issued a 20-page catalog entitled Materials for the Graphic Presentation of Facts. It deals with drawing room material, cross section paper, maps and other materials for statistical work, and in addition contains a list of books dealing with the general subject of graphic presentation of facts.

COMPRESSED AIR.—The Blaisdell Machinery Company, Bradford, Pa., has recently issued a loose-leaf catalog which is devoted to its line of air compressors, vacuum cleaning system and accessories. It is well illustrated and contains considerable information relative to the installation and operation of compressed air equipment in addition to the description of the devices manufactured by the company.

BOILER MAKERS' TOOLS.—A 40-page catalog has recently been issued by the J. Faessler Manufacturing Company, Moberly, Mo., which is devoted to the general line of boiler makers' tools manufactured by this company, together with its special flue cutting and countersinking tools. The catalog is well illustrated and contains price lists as well as information concerning the operation of the various tools.

TITANIUM ALUMINUM BRONZE.—An eight-page booklet just issued by the Titanium Alloy Manufacturing Company, Niagara Falls, N. Y., deals with the use of Titanium as a deoxidizer in alloys of aluminum and copper. The booklet contains a number of extracts from some reports setting forth the properties of aluminum and copper alloys, the practical casting of which has been facilitated by the use of Titanium.

FORGING HAMMERS.—Catalog No. 66 of the Chambersburg Engineering Company, which has just been issued, is devoted to

a representative line of the different types of steam hammers manufactured by this company. This is a 64-page, 8½-in. by 11-in. catalog in which the features of Chambersburg hammers are described in some detail. It contains a complete index of machinery built by this company, including several lines not shown in the catalog.

OXY-ACETYLENE APPARATUS.—Catalog No. 111 of the Imperial Brass Manufacturing Company, Harrison street and Racine avenue, Chicago, deals with oxy-acetylene welding and cutting outfits, torches, regulators, gages and other accessories. In addition to the usual information concerning such apparatus, the catalog contains a number of illustrations showing the torches in operation on various classes of work and examples of broken parts repaired by the Imperial outfit.

ELECTRIC HOISTS.—The Link-Belt Company, Chicago, in its bulletin No. 207 sets forth the special features of the Link-Belt electric hoists. These are of the monorail type, having a capacity up to four tons and are built with either a plain trolley, a geared trolley propelled by a hand chain, a motor driven trolley with pendant cords for operation from below, or with an operator's cage suspended from the hoist. These hoists may also be provided with a shackle or hook suspension in place of the trolley, making them suitable for stationary work.

HYDRAULIC PRESSES AND PUMPS.—The Hydraulic Press Manufacturing Company, Mount Gilead, Ohio, has issued a booklet in which a few of the various hydraulic appliances manufactured by this company are described and illustrated. The development of the business of this company as well as its present organization is briefly set forth and the plant described. The booklet is intended for distribution to visitors at the exhibit of this company at the Panama-Pacific International Exposition and contains a list of catalogs dealing in detail with various classes of hydraulic equipment, which are now ready for distribution.

FOUNDRY CRANES AND EQUIPMENT.—Catalog No. 99 from the Whiting Foundry Equipment Company, Harvey, Ill., is intended to furnish foundry men in condensed form descriptions and illustrations of the cranes and foundry machinery manufactured by this company for the equipment of complete foundry plants. The catalog contains 40 pages and is completely illustrated, the equipment covered including, besides cranes, overhead trolley systems, air hoists, cupola charging machines, bottom door hoists, elevators, core overs, core oven cars, ladles, tumblers, brass furnaces, sand sifters, converter steel, malleable foundry and pipe foundry plants.

OXY-ACETYLENE WELDING AND CUTTING.—The Vulcan Process Company, Minneapolis, Minn., has issued a pamphlet outlining the use of its oxy-acetylene outfit, which includes an acetylene generator, in railway shops. It contains descriptions of some of the work performed by this equipment with the corresponding savings made in doing the repairs by this method. A table is included showing the cost of cutting and the cost of welding. The cost per foot of cutting ranges from \$0.0126 for one-quarter-inch plate to \$0.041 for 1½-in. plate and the cost per foot of welding ranges from \$0.045 for one-eighth-inch plate to \$1.24 for five-eighths-inch plate.

STEAM ENGINE-DRIVEN GENERATOR SETS.—In bulletin No. 42,300, recently issued by the General Electric Company, Schenectady, N. Y., that company's line of small direct connected generating sets, of sizes ranging from 2½ kw. to 75 kw., is described. While ordinarily designed to meet the severe conditions of marine work demanding light, compact and durable sets of close regulation and quiet operation, they are also well adapted and used extensively for both power and lighting in isolated plants, and as exciters for alternating current generators in central station work. Both the engine and generator are described in the bulletin in considerable detail.

Railway Age Gazette

MECHANICAL EDITION

INCLUDING THE
AMERICAN ENGINEER

PUBLISHED ON THE FIRST THURSDAY OF EVERY MONTH BY THE
SIMMONS-BOARDMAN PUBLISHING COMPANY,
WOOLWORTH BUILDING, NEW YORK, N. Y.

CHICAGO: Transportation Bldg. CLEVELAND: Citizens' Bldg.
LONDON: Queen Anne's Chambers, Westminster.

EDWARD A. SIMMONS, *President* L. B. SHERMAN, *Vice-President*
HENRY LEE, *Secretary*

The address of the company is the address of the officers.

ROY V. WRIGHT, *Editor*
R. E. THAYER, *Associate Editor* A. C. LOUDON, *Associate Editor*
C. B. PECK, *Associate Editor*

Subscriptions, including the eight daily editions of the *Railway Age Gazette* published in June in connection with the annual conventions of the Master Car Builders' and American Railway Master Mechanics' Associations, payable in advance and postage free:

United States, Canada and Mexico..... \$2.00 a year
Foreign Countries (excepting daily editions).... 3.00 a year
Single Copy 20 cents

Entered at the Post Office at New York, N. Y., as mail matter of the second class.

WE GUARANTEE, that of this issue 6,350 copies were printed; that of these 6,350 copies 4,917 were mailed to regular paid subscribers, 250 were provided for counter and news companies' sales, 230 were mailed to advertisers, exchanges and correspondents, and 953 were provided for new subscriptions, samples, copies lost in the mail and office use; that the total copies printed this year to date were 25,900, an average of 5,180 copies a month.

The RAILWAY AGE GAZETTE, MECHANICAL EDITION and all other Simmons-Boardman publications are members of the Audit Bureau of Circulations.

Statement of the ownership, management, etc., of the *Railway Age Gazette, Mechanical Edition* (including the *American Engineer*), published monthly at New York, N. Y.:

Editor, Roy V. Wright, Woolworth Bldg., New York, N. Y.
Managing Editor, None.
Business Manager, None.
Publisher, SIMMONS-BOARDMAN PUBLISHING Co., Woolworth Bldg., New York, N. Y.
Owners, SIMMONS-BOARDMAN PUBLISHING Co., Woolworth Bldg., New York, N. Y.

STOCKHOLDERS:

EDWARD A. SIMMONS, New York. ROY V. WRIGHT, New York.
JESSE R. SIMMONS, New York. ELMER T. HOWSON, Chicago, Ill.
LUCIUS B. SHERMAN, Chicago, Ill. A. C. BOARDMAN, Riverdale, N. Y.
HENRY LEE, New York. F. BOARDMAN, Riverdale, N. Y.
SAMUEL O. DUNN, Chicago, Ill. B. BOARDMAN, New York.
RAY MORRIS, New York.

BONDHOLDERS:

S. W. DUNNING, New York. C. C. NEWCOMB, Brooklyn, N. Y.
ESTATE OF WM. H. BOARDMAN, N. Y.

SIMMONS-BOARDMAN PUBLISHING COMPANY,
By E. A. SIMMONS, President.

Sworn to and subscribed before Harry E. French, Notary Public for Kings County, N. Y. (No. 15), whose certificate is filed with the County Clerk of New York (No. 13), and whose commission expires March 30, 1916, on April 1, 1915.

VOLUME 89 MAY, 1915 NUMBER 5

CONTENTS

EDITORIALS:

Government Inspection of Railway Equipment..... 209
More Supervision Needed 209
Heat Treatment of Steel 210
Dead Weight in Passenger Equipment..... 210
Fashions in Locomotives 210
Shop Men or Railroad Men..... 211
Pulverized Fuel for Locomotives..... 211
New Books 211

COMMUNICATIONS:
Stresses in Side Rods 212

GENERAL:
Pulverized Fuel for Locomotives 213
Reciprocating and Revolving Parts 215
Educating Enginemen in Smoke Elimination 216
Gage for Pilot Coupler 216
Santa Fe Pacific Type Locomotive..... 217
Characteristics of Plate Springs 219
Water Tube Firebox on the Lackawanna..... 222
Good Features of Tender Tank Design..... 224
Tests of Lubricants 225
Feed Water Heater Used on Geared Locomotives..... 226

CAR DEPARTMENT:
Considerations Affecting the Type of Center Sills in Steel Passenger Equipment 227
Eight-Wheel Caboose with Steel Underframe 231
Improper Loading of Box Cars..... 233
Tests of Exhaust Ventilators 235
Step-Ladder for Sleeping Cars..... 238

SHOP PRACTICE:
Boring and Facing Back End Main Rod Brasses and Driving Boxes. 239
Pace Work and Bonus Systems in the Boiler Shop..... 240
Log for Grinding Guide Bars..... 242

Repairing Worn Air Pump Reversing Rods..... 242
Factors in Hardening Tool Steel..... 243
Guard for Vise Tail Piece..... 247
Does Modern Apprenticeship Pay?..... 248
Grinding Wheel Protection 249
Measuring Efficiency 249
Combination Rivet Set 251
Boiler Washing and Filling System for Small Roundhouses..... 251
Reclaiming Worn Lubricator Choke Plugs 252

NEW DEVICES:

Power Plant Oil Filter 253
Main Reservoir Ball Joint Connection..... 254
Locomotive Safety Valve 255
General Utility Vise for Drill Presses..... 255
Squirt Hose Ejector 256
Underframe Suspension of Car Lighting Generators..... 257
Piston Valves Applied to Slide Valve Cylinders..... 258
Hand Brake for Freight Cars..... 258
Emergency Jacks 259
Friction Spring Draft Rigging 259
Vacuum Oil Burner 260
Cloth-Lined Metal Weather Strips..... 260
Time Study Watch 261
Internal Guide for Pipe Threading Tools..... 261
Brine Tank Drain Valve 261

NEWS DEPARTMENT:

Notes 262
Meetings and Conventions 262
Personals 264
Supply Trade Notes 265
Catalogs 266

Government Inspection of Railway Equipment

In but a few isolated cases do we find that the federal inspectors of cars or locomotives have treated the railways under their jurisdiction unfairly, and after these cases were brought to the attention of the chief inspectors a distinct improvement was noticed. So far, it has been shown that the government inspection bureaus aim to do the square thing, but they do, at the same time, demand that the roads co-operate with them and show them the same consideration. The roads that have done this have found it much to their advantage. The inspection laws should be interpreted in a broad sense and every effort should be made to comply with the "intent of the law," an expression frequently used by the inspectors, which is to promote safety.

Mechanical department officers from the top to the bottom should so conduct their work that the inspectors will have absolute confidence in them. It is far better to come to a definite understanding on the ground than to try to "put something over," as it were, after the inspector leaves the premises. If an agreement cannot be reached and an injustice has been done the mechanical men in charge should comply with the inspectors' demands and then take the matter up through their superiors with the chief government inspector.

More Supervision Needed

The already extensive territory of some of the division master mechanics on a certain trunk line has recently been increased, and this without the appointment of any extra assistants. We believe that in general such a move is wrong; there are very few roads which would not benefit by reducing the extent of the territory of division master mechanics, and in this particular instance, where each man has jurisdiction over a division extending from 700 miles to 1,000 miles, considerable of which is double track carrying a dense traffic, it is difficult to follow the reasoning of those responsible for the change. Probably it was made on the basis of the old-established idea which still seems prevalent on railways, that an officer, to give the company his best service, should be so burdened with work that he never has time to think of anything else and is always at least a week behind in his correspondence. It is seldom economical to reduce supervision; on the contrary, economical results are much more likely to be obtained from an increase in the supervising forces, provided care is taken to make the organization effective. An officer who is overloaded with work cannot keep in close touch with his subordinates, who are quick to realize this, and in consequence become slack in both their movements and their thinking. Cases of cutting down the number of foremen or master mechanics arise not infrequently, but we have yet to learn of such a move resulting in economy.

Heat Treatment of Steel

Great advances have been made in the science of heat treatment of steel during the past 15 or 20 years. These have been simultaneous with the development and increasing use of alloy steels, the utility of which depends largely upon the care exercised to properly control the heating during the operations intervening between the manufacture of the steel and its final application as a finished product. While a thorough knowledge of this science and the application of the most approved methods and latest appliances are not as essential in the railway shop as in some other industries, they should not be considered as unnecessary refinements. All railways are extensive users of tools, many of which are manufactured in their own shops, and carbon or alloy heat treated steels are now being used for such locomotive details as crank pins, piston rods, side rods, frames, axles and many small valve motion parts. It is true that the larger parts, such as rods, axles, etc., may be purchased ready to finish in the machine shop, thus avoiding the necessity of handling the material in the railway blacksmith shop. However, in order to take full advantage of heat treated material, the railway shop must be equipped to handle it. While there are many skilled operators working with the open forge and depending upon color indications for temperature control, we believe that present day demands upon material fully justify the application of more accurate methods. In an article on hardening tool steel appearing on another page of this issue the numerous variables in the hardening process are discussed, some interesting data being included. We wish to call especial attention to the author's conclusion: "To expect uniformly good results from a hardener whom you have not provided with adequate or suitable equipment is unreasonable. When the question of good equipment in the way of furnace, quenching mediums, pyrometers, etc., has been satisfactorily taken care of, your hardener still has plenty of variables to contend with, which are beyond his control."

Dead Weight in Passenger Equipment

Since the all-steel passenger train is now a matter of every day railway service, it is interesting to consider comparative figures as to the weights of wooden and steel cars. The day coach of wooden construction, built within the past ten or twelve years, averaged in dead weight per seated passenger, assuming the full seating capacity as occupied, about 1,000 lb.; a similar average for the steel day coach is about 1,500 lb., with a minimum of 1,225 lb. One of the most recent wooden coaches used on a certain road weighs 91,000 lb., which, with a seating capacity of 62 gives a dead weight of 1,470 lb. per passenger. This figure seems high, particularly when we consider that the standard steel coach of the same road has a dead weight per passenger of 1,360 lb. A slightly older wooden car, on this road, with a total weight of 70,000 lb. seated 64 passengers, which is 1,090 lb. dead weight per passenger.

A steel frame day coach, of which there are a large number in service, has a total weight of 120,000 lb., seating 70 passengers, with a dead weight per passenger of 1,710 lb., while a steel coach used on still another road weighs 142,000 lb., with a seating capacity of 84, giving a dead weight per passenger of 1,470 lb. But on the average, the cars of a passenger train are not fully occupied and it is enlightening to look into the matter of dead weight hauled under such conditions. Considering first an all-wooden train of ten or fifteen years ago, consisting of a baggage car weighing, with load, 75,000 lb., four day coaches weighing 75,000 lb. each, and five sleeping cars weighing 100,000 lb. each, we have a total dead weight in the ten car train of 875,000 lb. If we assume 45 passengers in each of the coaches, the seating capacity of each coach being 64, and 30 in each sleeping car, which should be a very liberal average, we have a total of 330 passengers, which gives a dead weight per passenger in the train of 2,650 lb. Considering, now, a similar all-steel train, the baggage car and load weigh-

ing 130,000 lb., four day coaches weighing 142,000 lb. each and five sleepers weighing 150,000 lb. each, we have a total weight in the train of 1,448,000 lb., an increase over the all-wood train of 573,000 lb. Assuming the same number of passengers in each sleeper, and about the same proportion of the seating space as occupied in the day coaches, we have 60 passengers in each coach, or a total for the train of 390. This gives a dead weight per passenger of 3,700 lb., or an increase over the wooden car train of 1,050 lb., or 31 per cent, per passenger.

As before stated the figures employed for the number of passengers are liberal; there are hundreds of trains operated daily in which such a large proportion of the seating capacity is seldom occupied, and many of the seats are occupied for short distances, while the entire train has to be hauled through between terminals. Moreover, if we consider the day coaches as replaced by club cars, buffet library cars and dining cars we have a very common condition and one which is still more expensive for the railroads. The traveling public demanded and received all-steel equipment in passenger trains. With the resultant conditions as indicated above, is it unreasonable to expect the same traveling public to pay increased passenger fares?

Fashions in Locomotives

Under the heading "Why Use a High Factor of Adhesion in Steam Locomotives?" a correspondent in the Railway Age Gazette of April 9, 1915, page 778 says, in part: "From the standpoint of utilizing the greatest possible portion of the total engine and tender loaded weight in developing tractive effort, the ideal locomotive is the one in which all such weight is carried on the driving wheels. Where truck wheels must be used the same reasoning dictates that the weight on drivers shall be as large a proportion of the locomotive weight as is practicable. It is, therefore, surprising to note in how many instances designers fail to make use of even the weight actually carried on the drivers in deciding on the factor of adhesion. For example, why should it be necessary to use a factor of adhesion of from 4.5 to 5.0 or over when it has been fully demonstrated by locomotives now in successful operation that a factor of 4.1 or 4.2 is sufficient?"

In looking over a list of recent locomotives it is surprising to find in how many cases the factor of adhesion is higher than would seem to be warranted. It is, of course, easy to understand that in the case of a high speed passenger locomotive the desire for high boiler capacity in conjunction with driving wheels of large diameter, forces the designer to use a higher factor of adhesion than he would otherwise adopt, while in some cases the factor is purposely made high to prevent slipping of the driving wheels under difficult operating conditions.

But a consideration of the amount of effective weight on drivers leads naturally to that of the relation between the adhesive weight and the total locomotive weight. The trailer truck, by facilitating the use of a deeper firebox and larger boiler has unquestionably been a most material factor in increasing locomotive capacity; but it is also true that it has added considerably to non-productive locomotive weight. Pacific and Mikado type locomotives have been the means of solving many operating problems and there are many roads on which they could not well be dispensed with. But the fact remains that these two types are "in fashion" and for that reason and no other conceivable one have they been placed in service on some roads which would be just as well, if not better off with locomotives of the Consolidation or Ten-wheel type. We hold no brief for the non-trailer locomotive, but we are firmly convinced that the craze for locomotives equipped with trailer trucks has been carried to extremes and that if the necessary designing were put into the Consolidation or the Ten-wheel type they would in many cases prove as economical and efficient as locomotives of the Mikado and Pacific types, if not more so. If boiler capacity is the main essential, and it is found that this cannot be obtained in passenger service without the use of a

trailer truck, there remains the Atlantic type whose possibilities have never yet been exhausted, at least for low grade roads. This has been amply demonstrated by one conspicuous design of Atlantic type locomotive produced within the last three years. The locomotive designer has made rapid progress in America during the past few years, and we believe that if the best interests of the railways are to be served, still more attention must be given to matters of design and less to following fashions.

Shop Men or Railroad Men?

We have always devoted a considerable portion of each issue to matters bearing upon shop and engine house practice; it is of great importance that means be developed for more easily and quickly accomplishing the different classes of work pertaining to locomotive and car repairs. Improvements in shop methods mean a reduction in shop expenses with a consequent reduction in the drain on the company's treasury, and it is our aim to publish descriptions of such devices and practices as will tend toward such economies. It seems pertinent, however, to remind some of our shop friends that the repair shop is, after all, only a means to an end; its function is to so repair equipment that it will be most effective in earning money for the company. Unfortunately, quite a number of shop trained men become narrow in their viewpoint and look at the equipment problem only from a repair shop standpoint. We by no means intend to belittle a man who perfects a device that will save \$100 or \$50, or even \$1 in the repairing of a locomotive; the man who accomplishes such a saving is a valuable employee, but the man who can devise means of keeping a locomotive longer in service, that is, of increasing the number of miles run between shoppings, is much more valuable. The ideal condition, which, of course, is impossible of attainment, would be to keep locomotives and cars in continuous service. As equipment must needs undergo repairs, the company will be best served by the period between repairs being as long as possible and the time out of service undergoing repairs as short as possible. In general, it may be said that the shop man should strive toward repairing equipment as cheaply and at the same time as quickly and as well as possible, so that it will give a maximum mileage before again requiring shopping, cost a minimum for running repairs and give a maximum of economy in working, presupposing, of course, that it receives fair treatment while in service. This sounds like a pretty big order; it is, and no shop man can reasonably hope to even approximate such an accomplishment by looking at the problem from a shop standpoint alone. A shop man is a railroad man just as much as a division superintendent or a trainmaster or an engine house foreman is a railroad man, and he should look at his problems and attack them from a railroad standpoint.

Pulverized Fuel for Locomotives

The modern locomotive turns into useful work a considerably greater percentage of the heat units liberated in the burning of the coal than did the most efficient engine of ten years ago. The advances made in capacity and economical working have been the result of no single device or improvement, but rather of a combination of improvements. The superheater, the brick arch, the Mallet compound and the mechanical stoker are all factors in the increase of locomotive capacity; the three former have contributed extensively toward fuel and water economy, while improved design has undoubtedly helped in both economy and capacity. But the coal has still been burned in the same wasteful way on grates. With the successful completion of the experimental work connected with the use of pulverized fuel for steam generation in locomotives, a description of which will be found on another page, it should be of interest to consider briefly the possibilities of this method of combustion.

Enormous quantities of coal dust, slack, culm, etc., now go to waste at coal mines, in addition to which there are, princi-

pally west of the Mississippi river and in Canada, beds of sub-bituminous coal and lignite. Such fuels are obtainable at prices which are extremely low as compared with those now paid for coal suitable for burning on grates, but for various reasons they cannot be successfully burned in locomotive fireboxes. If, therefore, as is believed, such fuels can be successfully burned in a pulverized form, the effect on the cost of locomotive fuel, which at present constitutes about 25 per cent of the total cost of conducting transportation, can be readily seen. For example, some of the low grade western coals can be obtained at from 15 cents to 20 cents a ton, at the mine, but they cannot be utilized because of the amount of live sparks thrown from the locomotive stack, resulting in large fire losses along the right of way. In pulverized form, these same fuels can be placed on the locomotive tender at a total cost not to exceed from 50 cents to 75 cents a ton, and cinders, sparks and smoke are eliminated. Moreover, this development should be of great interest to coal operators, particularly in the West, as the large proportion of the coal that now goes to waste, but which costs just as much to mine as the salable grades, can be utilized for pulverization.

The smoke nuisance is the greatest argument of those who favor electrification, and it seems quite probable that pulverized fuel will be the means of postponing for many years some of the electrification schemes that have from time to time been urged, the capital that would have been necessary thus being available for other and more important betterment work. Aside from these important considerations, the application of pulverized fuel equipment to a locomotive is claimed to result in a direct saving of at least 20 per cent in fuel when the locomotive is working steam, as well as a saving due to the ability to extinguish the fire while standing on side tracks, at terminals and when drifting; there is a very considerable increase in the locomotive's sustained capacity, due to the reduction in back pressure and to the improved conditions of combustion; and the fireman has no heavy physical work, which should be the means of improving the standard of the men employed, with a corresponding effect on the standard of enginemen.

There must, of course, be considered the expense of drying and pulverizing machinery, but as the pulverized coal can be shipped to outlying stations in box or tank cars, it should not be necessary to equip more than a few terminals, and the savings effected in other ways should much more than offset this expense. For example, if lignite containing 9,000 B. t. u. can be pulverized ready for use at the mine tippie for 75 cents per ton, the saving through the use of this fuel as compared with coarse coal containing 13,500 B. t. u., costing \$2.50 at the mine, is self-evident, even neglecting the greater effectiveness in the water evaporation. Considered from any standpoint, the successful use of pulverized fuel, if it meets present expectations, would seem to be the greatest single advance made in locomotive development in recent years.

NEW BOOKS

United States Safety Appliances. Issued by the Master Car Builders' Association, Joseph W. Taylor, secretary, Chicago. 111 pages, 3 $\frac{3}{8}$ in. by 7 in. Bound in brown press-board. Price 25 cents.

This book contains the orders issued by the Interstate Commerce Commission concerning safety appliances, and includes the rules and illustrations for their application and maintenance.

Catechism of U. S. Safety Appliances. By J. D. MacAlpine, Collinwood, Ohio. 42 pages, 2 plates, 3 $\frac{1}{2}$ in. by 6 in. Bound in paper. Published by the author. Price, single copies, 15 cents; two copies, 25 cents; 12 copies, \$1.50; 100 copies, \$10.

This book covers the entire instructions of the Interstate Commerce Commission regarding safety appliances not only for freight cars but also for cabooses and passenger cars. It is arranged under headings for the different safety appliances, each

being considered separately. It is written in the question and answer form in order that those of limited education may more readily understand and comprehend the safety appliance rules.

The Mechanical World Pocket Diary and Year Book. 298 pages, net, 4 in. by 6 in. Bound in cloth. Published by Emmott & Company, Ltd., Manchester, England. Sold in the United States by The Norman Remington Company, 308 North Charles street, Baltimore, Md. Price 50 cents, postpaid.

This well known book contains a large amount of information covering a wide range of engineering subjects, all of which has been brought up to date in the new edition. Aside from the revision of material which the book formerly contained, a number of new sections have been added including some useful notes on gear cutting, a new section dealing with limit gages and another containing information relative to the strength of flat plates. A large number of tables are given, several of which are included for the first time this year, and many additional illustrations have been introduced. The present edition marks the twenty-eighth year of publication of the Pocket Diary and Year Book, and it has met with much favor because of its moderate price and the concise form in which the subject matter is arranged.

The Mechanical World Electrical Pocket Book. 224 pages, net, 4 in. by 6 in. Bound in cloth. Published by Emmott & Company, Ltd., Manchester, England. Sold in the United States by The Norman Remington Company, 308 North Charles street, Baltimore, Md. Price 50 cents, postpaid.

The electrical pocketbook is a companion volume of the well-known Mechanical World Pocket Diary and Year Book. The 1915 issue has been thoroughly revised and a number of new sections added. The section on electricity on shipboard has been rewritten and considerably extended, while additions have been made to the sections on electricity in coal mines, motor starters and others. A number of sections have been revised and condensed and as it now stands this little volume contains a large amount of up-to-date information covering the whole range of electrical engineering which should be especially useful to those in charge of electrical plants and machinery. Aside from the engineering information the book contains a number of mathematical tables and also includes a conveniently arranged diary. It is well indexed and its convenient size and low price commends it to those who desire a ready source of general information on electrical subjects.

Universal Safety Standards, Machine Shop and Foundry. By Carl M. Hansen, consulting safety engineer. Illustrated and indexed. 312 pages, 5 in. by 7½ in. Bound in leather. Published by the Universal Safety Standards Publishing Company, 12th and Race streets, Philadelphia, Pa. Price \$3.

This is the second edition of this book, which has been revised and enlarged. It is intended as a reference book of rules, drawings, tables, formulas and suggestions on safety devices and protection for machines in the machine shop and the foundry. It was compiled under the direction of and approved by the New York Workmen's Compensation Bureau. The book is classified into four parts, general, machine shop, foundry and rules and practices. Each division touches practically all cases that arise under that classification. The book is confined to the conservation of life and limb rather than the conservation of property, making it a valuable book for employers of labor. It gives a collection of conditions ordinarily found in machine shops and foundries, and indicates the proper safeguards to apply, treating the conditions with plain, clearly worded, brief specifications and illustrating these specifications with drawings. Conditions in the construction of the plant are taken up, and the product followed from the receiving department to the shipping room, showing how in each instance safety measures may be applied. The illustrations are particularly good, machines and buildings being printed in black and white, while the safety devices are printed in color which makes them stand out very clearly.

COMMUNICATIONS

STRESSES IN SIDE RODS

ALTOONA, Pa.

TO THE EDITOR:

In the article on Reciprocating and Revolving Parts, pages 109 to 115, issue of March, 1915, there is a statement that the stress in the front and back stub eye of Pennsylvania Railroad rods is 26,500 lb. per sq. in. for the Atlantic type, and 31,700 lb. per sq. in. for the Pacific type. If the stresses in the rods ran this high the rods would not last a week. It is quite apparent that in determining this bending stress the author used the wrong method.

Referring to the eye of the rod, shown in Fig. 12, page 115: It will be noted that the inside diameter of the eye is 8 in. and the outside diameter 11 in. The bearing consists of a solid brass bushing, 1 in. thick, forced into the rod by hydraulic pressure. The circular shape of the rod eye cannot be changed without permanently compressing the bushing. There are three conditions to be considered. The pressure with which the bushing is put on may be too high. In that case the limit of the stress in the eye of the rod must be based on the elastic compressive strength of the bushing, and, with this as a basis, the bursting pressure of the eye, considered as a shell with pressure inside, must be determined. On this basis the stress is somewhat less than 12,500 lb. per sq. in.

The normal condition is when the bursting effect from the bushing is equal to the effect from tension on the rod, in which case the stress in the fibres on the circumference of the 8-in circle is 8,500 lb. per sq. in., and that on the circumference of the 11-in. circle is 5,000 lb. per sq. in.

The third condition covers a loose bushing, in which case the maximum stress is on the outer fibre, and may reach the value of nearly 10,500 lb. per sq. in.

As a matter of fact, when rods become defective after they have been in service, the breakages seldom, if ever, occur on the horizontal center line of the eye; they usually occur through the oil cup.

The author of the article also makes the statement that there is no really satisfactory formula for the design of pistons. As a matter of information, the writer begs to refer to an article by John Kraft, translated by J. Rennie, on page 248 of the Minutes of Proceedings of the Institution of Civil Engineers, Volume CXXXVII, published in 1897.

W. F. KIESEL, JR.,

Assistant Mechanical Engineer, Pennsylvania Railroad.

[EDITOR'S NOTE.—The author of the article did not intend to convey the impression that the stresses given were actual. They are empirical, the idea being that if by a certain formula the stress at any particular section does not exceed a predetermined amount the rod is safe. The stresses of 26,500 lb. and 31,700 lb. referred to above, are not actual stresses; they are simply comparative figures derived from using a certain empirical formula that has proved its value by many years' practical use.]

QUALITIES OF MAGNET STEEL.—In a paper presented to the English Institution of Automobile Engineers it was pointed out that while permanent magnet steel usually contains tungsten, the process of hardening it is one that requires great knowledge and care, the magnets being always very hard but not necessarily glass hard. If a long and short magnet are made of the same steel, the short one must be rather harder than the long one to get the best results out of each. The two qualities required in a magnet are high magnetization and permanence. The great bulk are small and for scientific instruments, but must possess as nearly absolute permanency as possible and need not be very strong. Magnets for a magneto, however, are large and therefore more difficult to harden uniformly. They must be as powerful as possible and reasonably permanent.—*American Machinist.*

PULVERIZED FUEL FOR LOCOMOTIVES

Tests Conducted Under Severe Operating Conditions Have Proved Satisfactory; Future Possibilities

The use of pulverized coal for heat-producing purposes is not new, this fuel having been extensively used for many years in cement and metallurgical furnaces, but while experiments have from time to time been conducted with a view to its use in the generation of steam, they were never developed to a practical and commercial conclusion.

There are many reasons why a successful application of a means of burning pulverized fuel in locomotive fireboxes should be looked upon favorably. Such combustion is smokeless and there are no cinders or sparks thrown from the stack. The first of these items would bring the use of pulverized coal into careful consideration in congested terminal districts where public opinion is forcing the railways towards expensive electrification projects, while the second shows its value in the operation of steam locomotives through forests and other regions where fires are easily set. Furthermore, with the rapid inroads which are being made in the more superior qualities and grades of fuel supply of the United States, and, in fact, of the world, the cost of coal is rapidly increasing. With the application of pulverized coal burning apparatus, use can be made of the dust and refuse from mines as well as peat, petroleum coke, coke breeze, lignite and other low grade coals which are under present conditions unsatisfactory for steam production in locomotives.

To produce the best results as regards complete combustion and the least trouble from ash and slag, pulverized coal should contain not more than 1 per cent moisture and be of a uniform

cent of the coal dried. It will, of course, be necessary in railroad work to equip the existing principal coaling stations with machinery for crushing, grinding, drying and conveying the coal to a suitable storage plant as well as to the locomotive tenders.

The work of developing equipment for burning pulverized coal in steam locomotives has been carried out during the past year and a half and the results have now assumed a final and definite form, so that it is possible to give in what follows a general idea of what has been accomplished. The equipment referred to in this article has been developed by the Locomotive Pulverized Fuel Company, 30 Church street, New York, and while it is not possible to describe it at present in detail, it is expected that a more detailed description of the apparatus will be available at a later date. In order to determine the commercial practicability of the appliances which have been developed, application was made to a ten-wheel locomotive of about 31,000 lb. tractive effort, 200 lb. working steam pressure, 22 in. by 26 in. cylinders, 69 in. diameter driving wheels, 55 sq. ft. of grate area and equipped with a Schmidt superheater.

The experimental work has been carried out on this locomotive almost continuously since early in June, 1914, on a ruling grade from $6\frac{1}{2}$ to 8 miles long and also on a district of 92 miles. Some of the indicator diagrams obtained are shown below for the purpose of illustrating the relatively low cylinder back pressure. As originally built the locomotive had an ex-

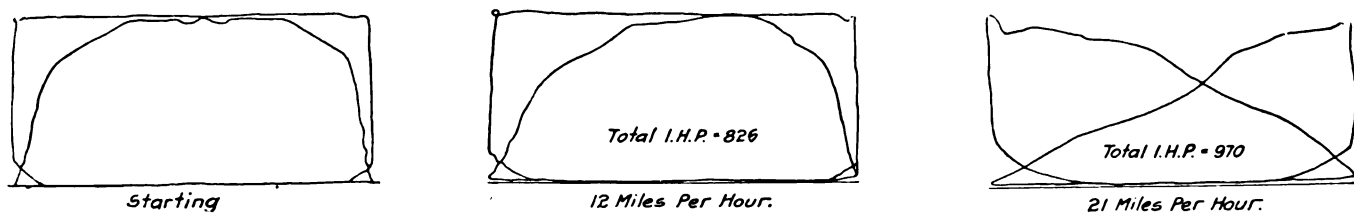

Indicator Diagrams Taken on a Locomotive Burning Pulverized Coal, Showing Low Back Pressure

fineness, so that not less than 95 per cent will pass through a 100 mesh and not less than from 80 to 85 per cent through a 200 mesh screen. Coal must, of course, be dried either before grinding it or when burning, this being an item of expense that is necessarily present regardless of whether the coal is burned on grates or in suspension in the powdered form. When coal which is not dry is fed into a furnace the moisture is evaporated, which means that an added quantity of coal must be burned to maintain the temperature, the latter being reduced about 72 deg. F. for each one per cent of moisture entrained. As this cannot be overcome by feeding additional fuel with the same percentage of moisture, the loss of heat is about two per cent for each one per cent of moisture, this loss being further increased when applied to the usable heat above the temperature of the escaping smokebox gases. If the coal is dried before grinding, however, the cost for drying will be almost saved because of the decreased power required for pulverization and also because of the improved combustion resulting from the greater degree of fineness obtained in the dried as compared with the moist coal.

The cost for preparing pulverized coal varies with the cost of the coarse coal and with the moisture content. However, from data obtained during the past 10 years, assuming the cost of the coal at from \$1 to \$2 a ton, the total cost for preparation will vary from 25 cents to 50 cents in the case of a plant having a capacity of two tons (of 2,000 lb.) per hour to a cost of 10 cents to 20 cents in a plant of a capacity of 25 tons per hour. The amount of fuel required for drying the coal averages from one to two per

cent of the coal dried. It will, of course, be necessary in railroad work to equip the existing principal coaling stations with machinery for crushing, grinding, drying and conveying the coal to a suitable storage plant as well as to the locomotive tenders. The work of developing equipment for burning pulverized coal in steam locomotives has been carried out during the past year and a half and the results have now assumed a final and definite form, so that it is possible to give in what follows a general idea of what has been accomplished. The equipment referred to in this article has been developed by the Locomotive Pulverized Fuel Company, 30 Church street, New York, and while it is not possible to describe it at present in detail, it is expected that a more detailed description of the apparatus will be available at a later date. In order to determine the commercial practicability of the appliances which have been developed, application was made to a ten-wheel locomotive of about 31,000 lb. tractive effort, 200 lb. working steam pressure, 22 in. by 26 in. cylinders, 69 in. diameter driving wheels, 55 sq. ft. of grate area and equipped with a Schmidt superheater. The experimental work has been carried out on this locomotive almost continuously since early in June, 1914, on a ruling grade from $6\frac{1}{2}$ to 8 miles long and also on a district of 92 miles. Some of the indicator diagrams obtained are shown below for the purpose of illustrating the relatively low cylinder back pressure. As originally built the locomotive had an exhaust nozzle 5 in. in diameter, this being approximately 19.6 sq. in. in area. The nozzle used with the pulverized coal apparatus was rectangular, $5\frac{1}{2}$ in. by 8 in., giving an area of 44 sq. in. With the original nozzle the back pressure at speeds of from 15 to 20 miles an hour was from 8 lb. to 11 lb., while with the rectangular nozzle the back pressure at the same speeds was from 1 lb. to 3 lb. The reduction in back pressure much more than compensated for the steam consumption of the turbo-generator as well as for any use made of the steam blower while at the same time increasing the locomotive's capacity and reducing wear and tear on the machinery. The turbo-generator, which is of 10 kw. capacity, is placed at the forward end of the locomotive in front of the smokebox or in any other convenient location, and supplies current for two motors driving the conveying and blowing machinery, located on the front of the tender, which carries the coal into the firebox.

The smokebox temperatures obtained were from 425 deg. to 490 deg. F., while the corresponding firebox temperatures ranged from 2,600 deg. to 2,850 deg. F. On no occasion did the locomotive stall because of insufficient steam; in fact, the safety valves were open at all times when the engine stalled. The tests were all conducted under the most severe conditions possible, namely, cold weather, low volatile coal, coarse pulverization of the coal, full tonnage rating and in many instances more than full rating.

The tonnage hauled on the maximum ruling grade ranged from the regular summer rating to 15 per cent greater than the summer rating in freezing weather and the locomotive accelerated

the train in numerous instances on the ruling grade to speeds of from 20 to 25 miles per hour.

The coal used in these tests was ordinary bituminous coal and contained from 21 to 26 per cent volatile matter and about 15 per cent of non-combustible. When fed at the rate of 2,500 lb. to 4,000 lb. per hour the various smokebox gas analyses showed an average of less than 1 per cent of free oxygen or carbon monoxide and from 11 per cent to 14 per cent of carbon dioxide. The evaporation obtained ranged from 9½ lb. to 12¼ lb. of water per pound of coal from and at 212 deg. F.

The coarsest grade of the coal ran 39.6 per cent through a 200 mesh screen, 20 per cent on a 200 mesh screen and 40.4 per cent on a 100 mesh screen. The finest grade ran 66½ per cent through a 200 mesh screen, 95½ per cent through a 100 mesh screen and 98½ per cent through an 80 mesh screen. According to statements made before the American Society of Mechanical Engineers, the most satisfactory results are obtainable from coal which will run from 80 to 82 per cent through a 200 mesh screen and 95 per cent through a 100 mesh screen. Analyses of the coal used showed that it ranged from .67 per cent moisture,

compared with ordinary hand firing, but it has so far been impossible to compute this definitely. No change is necessary in the boiler of the locomotive other than to remove all of the smokebox draft appliances and the grate and ashpan equipment. The pulverized coal blower and combination conveyors, feeders and mixers are attached to the front of the tender coal space and the coal tanks can be applied to many tenders as at present constructed. This coal container is so arranged as to be usable for either pulverized coal or fuel oil, and the entire equipment can be readily changed without extra cost for burning fuel oil. The Security brick arch is used in the firebox and special brick work is used below the arch and mud ring. The refuse runs down into a collection pan below the firebox in the form of a slag, which when hardened is of a glassy nature and is very easily broken and falls out when the pan is opened. About 2.5 per cent of the weight of the coal fired when it contains 15 per cent of non-combustible is deposited in the slag pan in the form of concentrated slag as compared with about 15 per cent accumulation in the ashpan when coal is burned on the grates. This is due largely to the slag containing no combustible

100 Per Cent of Total Capacity Utilized.								
1%	2%	3%	4%	5%	6%	7%	8%	
<i>Electric Power - All Elements Affected.</i>					← 5.79%			
<i>Steam Loco. - Pulverized Fuel - Superheater.</i>				← 4.57%				
<i>Steam Loco. - Hand Fired - Superheater - Security Arch.</i>			← 4.01%					
<i>Steam Loco. - Pulverized Fuel - Saturated Steam.</i>		← 3.31%						
<i>Steam Loco. - Hand Fired - Sat. Steam - Arch.</i>		← 2.69%						

75 Per Cent of Total Capacity Utilized.								
1%	2%	3%	4%	5%	6%	7%	8%	
<i>Electric Power - All Elements Affected.</i>					← 5.95%			
<i>Steam Loco. - Pulverized Fuel - Superheater.</i>				← 5.76%				
<i>Steam Loco. - Hand Fired - Superheater - Security Arch.</i>			← 4.83%					
<i>Steam Loco. - Pulverized Fuel - Saturated Steam.</i>		← 4.72%						
<i>Steam Loco. - Hand Fired - Sat. Steam - Arch.</i>		← 3.84%						

50 Per Cent of Total Capacity Utilized.								
1%	2%	3%	4%	5%	6%	7%	8%	
<i>Electric Power - All Elements Affected.</i>				← 4.54%				
<i>Steam Loco. - Pulverized Fuel - Superheater.</i>						← 7.05%		
<i>Steam Loco. - Hand Fired - Superheater - Security Arch.</i>					← 5.87%			
<i>Steam Loco. - Pulverized Fuel - Saturated Steam.</i>				← 5.41%				
<i>Steam Loco. - Hand Fired - Saturated Steam - Security Arch.</i>			← 4.75%					

Comparison of Thermal Efficiency of Electric and Steam Motive Power. Showing Percentage of Power Delivered at the Rail for 100 Per Cent B. T. U. in the Coal

65.16 per cent fixed carbon, 21.63 per cent volatile matter, and 13.12 per cent ash with 13,671 B.t.u. per lb., to .88 per cent moisture, 25.67 per cent volatile matter, 63.05 per cent fixed carbon and 10.4 per cent ash with 13,912 B.t.u. per lb. In the statements before the American Society of Mechanical Engineers, referred to above, 30 per cent volatile matter was generally mentioned as a minimum for the best results. The capacity of each combination conveyor, feeder and mixer ranged from about 250 lb. of coal per hour at the lowest speed of 23 revolutions per minute of the feed screw to about 1,600 lb. of coal per hour at a speed of 133 revolutions per minute, this capacity being susceptible to increase or decrease as the demands of the locomotive may require.

The locomotive steamed satisfactorily throughout the tests; in fact, more steam was produced than was required, and there was no smoke. The exhaust steam assumed at times a slightly grayish color, but at no time was there any evidence of dust or ashes, and no cinders or sparks were emitted. There is a saving of from 15 per cent to 25 per cent in coal consumed as

whatever, whereas ordinary ashpan residuum usually contains considerable combustible.

The cost for preparing pulverized coal should, it is believed be more than offset by the difference in mine cost of the mine refuse and sweepings as well as lignite and other inferior grades of coal, as compared with fuel that must be used when burning on grates. Considerable savings in the matters of inspection, maintenance and operation are also indicated through the complete elimination of grates, ashpans, smokebox netting, hand-hole plates and spark hoppers, firing tools and squirt hose, as well as prevention of loss of fuel from the open coal space. There is very little collection of ash in the tubes and terminal and intermediate delays due to cleaning and dumping fires and blowing out tubes are also avoided and the facilities for performing such work are practically eliminated. There being no cinders, cutting of superheater elements, etc., is eliminated. The cost of building fires is also reduced to a minimum, as no special fuel or labor is required for this purpose, it being only necessary to light a piece of oily waste or other refuse material to start the

fire. The fire can be extinguished when the locomotive is on sidings and at terminals, or when drifting, thus saving fuel, and it will restart from the heat of the furnace within an hour without relighting. When building fires, 200 lb. steam pressure can be obtained from water at 40 deg. F. in 45 or 50 min. The physical requirements of firing a locomotive are reduced to those of firing with oil, while at the same time a more constant firebox temperature and more uniform steam pressure are claimed to be available under varying operating conditions. Relieving the fireman of the arduous physical exertion of hand firing should result in an improved standard of applicants for this position, making it correspondingly easier to develop higher class enginemen.

The following figures should be of interest as bearing on the cost of electrification as compared with that of equipping an average modern type of locomotive for burning pulverized fuel: Cost of a new Consolidation type locomotive of 50,000 lb. tractive effort, equipped with superheater and

(a) for handfiring and burning coal on grates, approximately.....	\$22,000
(b) for burning fuel oil in suspension, approximately.....	22,750
(c) for mechanically stoking and burning coal on grates, approximately.....	24,000
(d) for automatically stoking and burning pulverized coal, lignite, peat or fuel oil in suspension, approximately.....	26,500
(e) cost of electric locomotive, approximately.....	50,000

Throughout the entire series of tests no trouble whatever was experienced with explosions, no tendency was found for any explosion to take place and there was no blow-back and noise such as occurs where fuel oil is used. In general, the firing of pulverized coal is conducted by means of one of two methods, one being known as the short flame method and the other as the long flame method. In the application to locomotives a combination of the two methods has been employed.

One of the illustrations shows a diagram of the thermal efficiency of electric and steam motive power under different conditions. The top portion of this diagram, in which 100 per cent of the total maximum capacity or load factor is assumed as utilized, is obviously an ideal condition and one which never obtains in actual service, the condition in which 50 per cent is utilized being more nearly the average for steam road operation. With electrical operation this load factor seldom exceeds 35 per cent. It will be noticed that under these conditions pulverized coal shows up as extremely advantageous. These figures do not consider any emergency power plant or storage battery equipment for electrical operation.

RECIPROCATING AND REVOLVING PARTS†

BY H. A. F. CAMPBELL*

PART II—ALLOY AND HEAT-TREATED CARBON STEEL

Thirty years ago it was a difficult matter to convince engineers that steel was better than wrought iron for axles, pins or connecting rods, yet today a wrought iron axle or pin is hard to find. In the same way many engineers are now uncertain as to the advisability of using either heat-treated carbon steel or heat-treated alloy steel.

is freed from all internal forging strains. In alloy steels, when heat-treated, the elastic limit can be very greatly increased in relation to the ultimate strength, but without sacrificing ductility. No two pieces of steel, however, are alike in their chemical composition and even if they closely approach each other in this respect, the difference in mechanical treatment during their manufacture causes them to possess widely different physical properties. The method of forging, that is, the size of the original ingot in relation to the size of the final forging, the amount of work put upon this ingot, and the rate of reducing the metal, all have a most important bearing upon the final physical quality of the steel. When an alloy steel is used, the care which is put into the forging process helps greatly in obtaining desirable physical qualities. The alloy of nickel or chrome or vanadium makes a marked difference in the structure of the steel, but just as much is it the time and care that has been put into the forging.

To date the use of alloy steel for locomotive piston rods, connecting rods, stub straps or wrist pins has been limited; chrome-vanadium steel has been used for a few sets of these parts. But advantage has not been taken of the opportunity to reduce the weight by working the steel up to its full capacity as regards strength. Nickel-chrome steel has been used in only two sets of these parts in recent years; details of their design have already been given in this article. In this case full advantage was taken of the increased strength of the steel to reduce the weight. Ten years ago some nickel-chrome steel crank axles were made in this country. These crank axles are running today, having made over 1,000,000 engine miles. This metal has proved to be a good bearing surface for the crank pins. Chrome-vanadium and nickel-chrome crank pins have shown excellent wearing qualities.

Table XII gives the chemical and physical properties that should be obtained from .45 carbon steel, .45 carbon steel heat-treated, chrome-vanadium steel heat-treated and nickel-chrome steel heat-treated.

In many cases fractures of rods are due to failure on the compression side of the member and not to failures on the tension side. That being the case, it is very important to know what is the compressive strength of these steels. Many tests of the tensile strength are available, but there are very few tests of the compressive strength. The few tests that have been made on such sections as apply to the parts under consideration have shown that in compression members, when

1 — does not exceed 150, the ultimate compressive strength p

is about equal to, or a little less than, the tensile elastic limit. This relation has been discussed by Prof. Lanza in the proceedings of the American Society for Testing Materials, Vol. VII, 1907, page 281, and seems to be pretty well established. We have, then, a means of determining approximately the ultimate compressive strength. The writer does not know of any compressive tests on full size parts made of chrome-vanadium or nickel-chrome steel. When such tests are made

TABLE XII.—PROPERTIES OF VARIOUS STEELS

Kind of steel	Carbon	Chrome	Nickel	Vanadium	Ultimate strength, lb. per sq. in.		Limit elastic	Elongation in 2 in., per cent
					Tension	Compression		
O. H. carbon.....	.35 to .45	75,000	32,000	35,000	20
O. H. carbon, heat-treated.....	.35 to .45	85,000	46,000	50,000	20
Chrome-vanadium, heat-treated.....	.28 to .42	.75 to 1.14	Not under .15	100,000	60,000	65,000	20
Nickel-chrome, heat-treated.....	.35 to .40	.25 to .28	1/4	100,000	60,000	65,000	20

If we wish a material to resist shock loads, alternating and repeated stresses, we should choose one possessing high elastic limit and good elongation; and in the case of a forging, the work should be particularly well done so that the material

the results should follow closely those given in table XII. There is no reason why they should not, but until such time it would seem conservative to consider the ultimate compressive strength as 90 per cent of the tensile elastic limit. This means that alloy steel, if considered from the compressive side alone, is about 45 per cent stronger than regular

*Baldwin Locomotive Works, Philadelphia, Pa.

†Part I appeared in the March and April, 1915, issues, pages 109 and 163.

non-heat-treated .45 carbon steel, or about 20 per cent stronger than heat-treated .65 carbon steel.

At the December, 1914, meeting of the American Society of Mechanical Engineers, C. D. Young, engineer of tests of the Pennsylvania Railroad, and H. V. Wille, of the Baldwin Locomotive Works, discussed heat-treated carbon and alloy steel and high carbon steel for locomotive parts. A table showing the ultimate strength and the allowable working stresses for these different steels was given.* Mr. Wille brought out an important point, namely, that we have not yet obtained all that is possible from carbon steel. His idea was that if a higher carbon steel were used, say .65 carbon oil-tempered, with a slightly reduced elongation, say 15 per cent, results equally as good as those from alloy steels could be obtained.

It is to be hoped that more tests on full-sized sections of these different steels can be made. The results would be of great value and would form a basis for further study of the relative merits of the steels now so much under discussion.

EDUCATING ENGINEMEN IN SMOKE ELIMINATION†

The education of enginemen in the elimination of smoke must by no means be restricted to the firemen. The engineer is in direct control of the fireman while they are on the engine and unless he too is instructed, interested, and his co-operation obtained, the effect of the fireman's instruction will be materially lessened. Most of the engineers were educated in the art of firing at a time when it was thought that a locomotive must make smoke in order to get steam, and this idea must be removed from their minds.

The principal factor to be considered in the matter of instruction is the instructor. He should be one who has not only had a thorough practical experience, but a sufficient technical education concerning the process of combustion. In addition he should be a man who knows how to handle men, and at the same time, be capable of so imparting his knowledge to them that they will become thoroughly interested in their work. A road foreman of engines is, perhaps, one of the best men for this work. One of the greatest difficulties the instructor will meet in his endeavor to establish new rules and educate enginemen along the lines of proper combustion, will be in making them realize the fact that in order to utilize as nearly as possible all the heat contained in the coal, a locomotive must be fired in such a manner as to consume the hydrocarbon gases of the fuel as well as the coke or fixed carbon. In other words, if they are fired with a minimum amount of smoke, a maximum of economy will obtain.

The locomotive fireman in attempting to obtain smokeless combustion has a much more difficult problem than the fireman of a stationary plant, for the latter has constant and stable conditions to deal with, while the former is required to furnish steam for maximum and minimum power requirements within small intervals of time. In this respect the engineer, by informing the fireman as to his intended operations, can minimize his difficulty.

An applicant for the position of locomotive fireman should be at least 21 years of age, have a common school education, good habits, and be accustomed to hard labor. When first employed he should be instructed on combustion and provided with literature on this subject so written that it can be easily understood. He should be instructed on the rules pertaining to the movement of trains, which can be most successfully accomplished by requiring the student fireman to ride with a competent engine crew. Then the road foreman, or the traveling

fireman, should take him in hand and demonstrate by actual practice the advantages of complete and smokeless combustion, at the same time explaining the process of combustion as much as possible while on the road. The operation of smoke consumers used should be thoroughly explained and their effect demonstrated by actual operation so that it may be clearly shown why it is necessary to admit air above the fire. The student fireman should also be instructed as far as possible in the judging of the temperature of the firebox by the appearance of the fire; also, considerable benefit may be obtained by giving lectures to the enginemen on combustion, showing stereopticon views which will not only interest the men, but give them something definite to keep in their minds. Above all, both the road foreman of engines and the engineer should co-operate with the fireman so that he will realize that interest is being taken in his welfare.

GAGE FOR PILOT COUPLER

BY H. C. SPICER

Gang Foreman, Atlantic Coast Line, Waycross, Ga.

A coupler gage which is very convenient for gaging the height of pilot couplers is shown in the accompanying drawing. The gage may be made from $\frac{1}{4}$ in. or $\frac{3}{8}$ in. by 1 in. common iron, and the stem graduated in half-inches beginning at 32 in. and

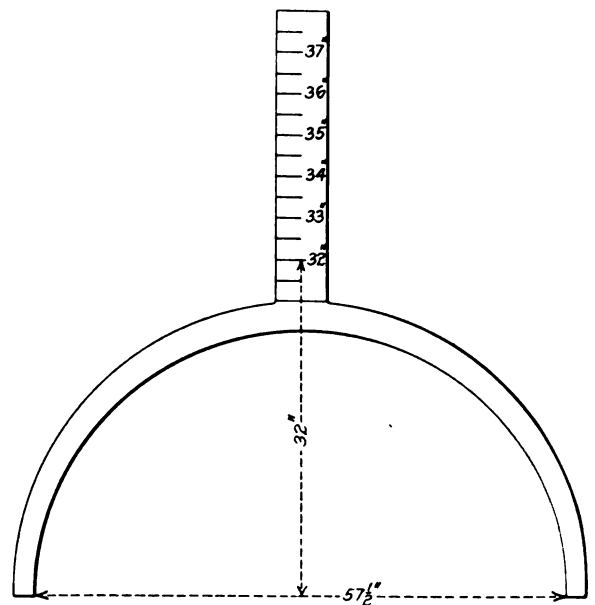

Device for Gaging the Height of Pilot Couplers

continuing upward. The circular shape of the base will permit of its being used over the nose of the pilot.

COLE-SCOVILLE TRUCK.—In the description of a 2-10-2 type locomotive recently built by the Baldwin Locomotive Works for the Erie Railroad, which appeared on page 158 of our April issue, it was stated that the locomotive was equipped with the Cole trailing truck. Our attention has been called to the fact that the correct name of this truck, which is of the outside bearing type with a hinged or floating yoke, is the Cole-Scoville truck.

MACHINING CAST IRON.—To overcome tool trouble in machining small gray-iron castings, an annealing process is often effective. A process claimed to accomplish excellent results is to pack the castings in cast-iron chips (with some broken charcoal to make a reducing atmosphere to prevent scaling) in ordinary annealing boxes. The castings are then heated to a good red heat and kept there for several hours, the time varying with the size of the pieces. Slow cooling is then permitted to take place.—*American Machinist.*

*See *Railway Age Gazette, Mechanical Edition*, January, 1915, page 13.

†From a paper presented at the ninth annual convention of the International Association for the Prevention of Smoke.

SANTA FE PACIFIC TYPE LOCOMOTIVE

Single Expansion Engine Equipped for Burning Fuel Oil; Maximum Tractive Effort 41,000 lb.

The Atchison, Topeka & Santa Fe received from the Baldwin Locomotive Works a simple Pacific type locomotive, which now forms a part of the exhibit of the builders at the Panama-Pacific International Exposition at San Francisco, Cal. It is the first single expansion* engine to be built for passenger service on the Santa Fe system in some years.

The locomotive is designed to develop the maximum possible capacity within a limiting rail load of 58,000 lb. per pair

at the third course. A circular opening 16 in. in diameter under the auxiliary dome permits entrance to the boiler without dismantling the standpipe and throttle fittings in the main dome. The boiler is equipped for oil burning, but the staybolts are so located that arch tubes may subsequently be applied should it be necessary to fit the locomotive for coal burning service. The inside firebox door sheet is flanged outward, bringing the rivet heads in the water space, and the seam is closed

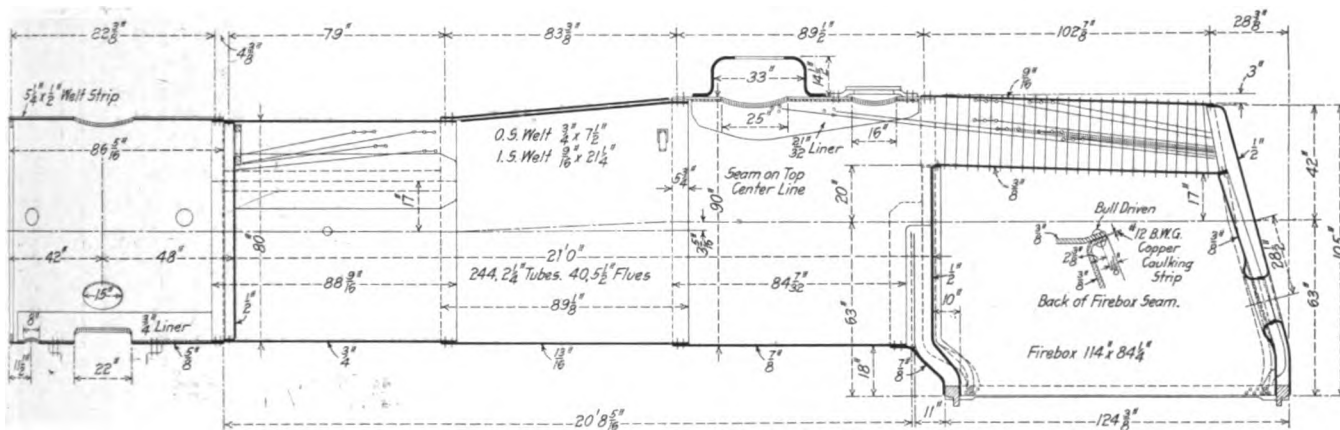

Boiler of the Santa Fe Simple Pacific Type Locomotive

of driving wheels, and the total weight on the driving wheels of 172,500 lb. closely approaches this limit. The design was prepared jointly by the railway company and the builder and, as in all recent Santa Fe locomotives, the details have been designed to interchange as far as practicable with those of locomotives already in service. The new locomotive develops a tractive effort of 41,000 lb., with a factor of adhesion of 4.2, and has a total equivalent heating surface of 5,913 sq. ft. The ratio of cylinder tractive effort to equivalent heating surface is

with a copper caulking strip. The O'Connor fire door flange is used and the door seam is welded by the autogenous process. Flexible staybolts are used in the breakage zones in the throat, sides and back as well as in the first four rows of crown stays. The boiler is equipped with a Schmidt superheater of 40 elements with a superheating surface of 980 sq. ft., and among the special fittings is included the Chambers throttle.

The cylinder castings are strongly built with liberal steam and exhaust passages. The steam distribution is controlled by 16-

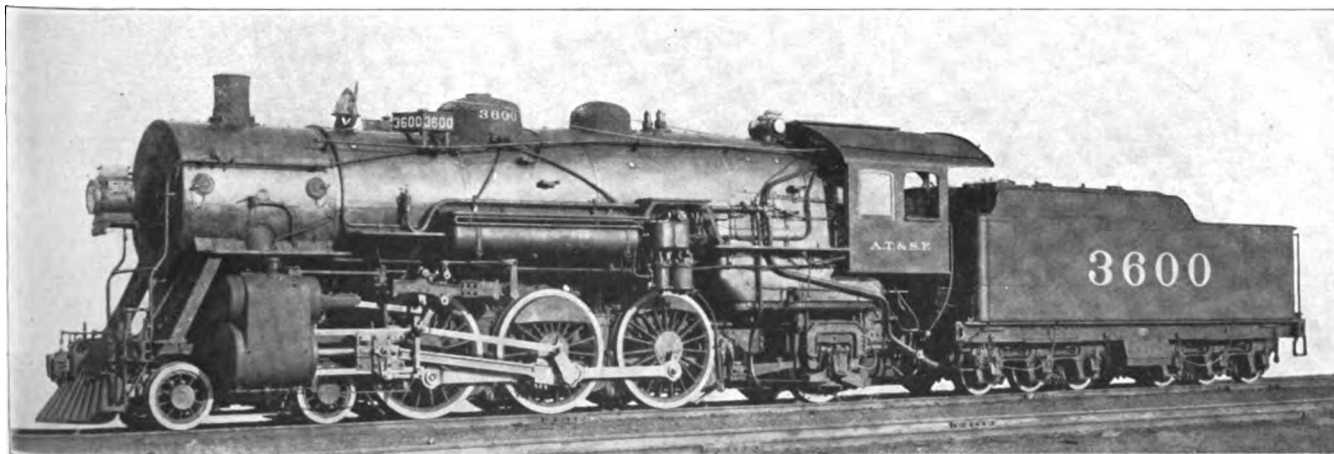

Simple Pacific Type Locomotive for the Atchison, Topeka & Santa Fe

306.17, which indicates a capacity for high sustained performance. The boiler is composed of three courses, the middle course being tapered, with the slope at the top, and the main and auxiliary domes are placed on the third course. The diameter of the first course is 80 in., which is increased to 90 in.

in. piston valves driven by the Baker valve gear. The valves are set with a lead of one-quarter inch and cut off at 87 per cent when in full gear. The Ragonnet power reverse gear is used.

The frames are of steel and are each cast in two sections with the splice located back of the rear driving pedestals, the main sections having a width of 5 in. The splice has a slab fit with a large bearing area and is secured by 18 horizontal 1 1/8 in. bolts

*For descriptions of Santa Fe balanced compound Pacific type locomotives see *Railway Age Gazette*, June 19, 1914, page 1519, and *American Engineer*, October, 1912, page 515.

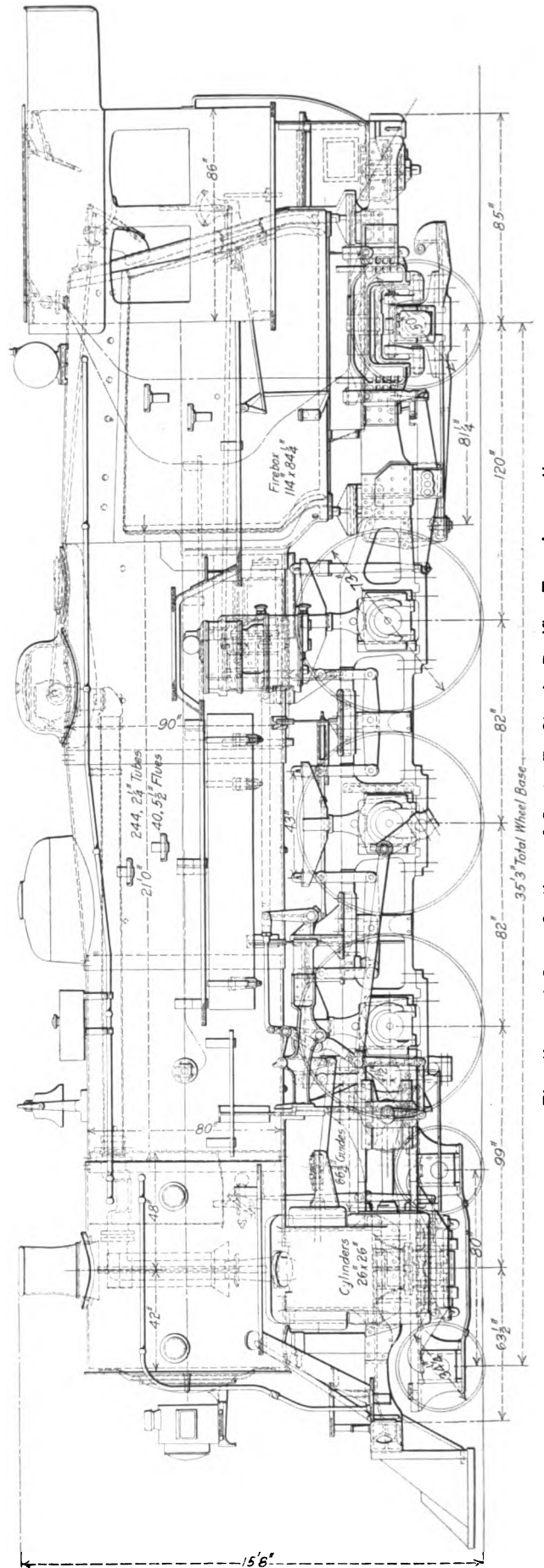
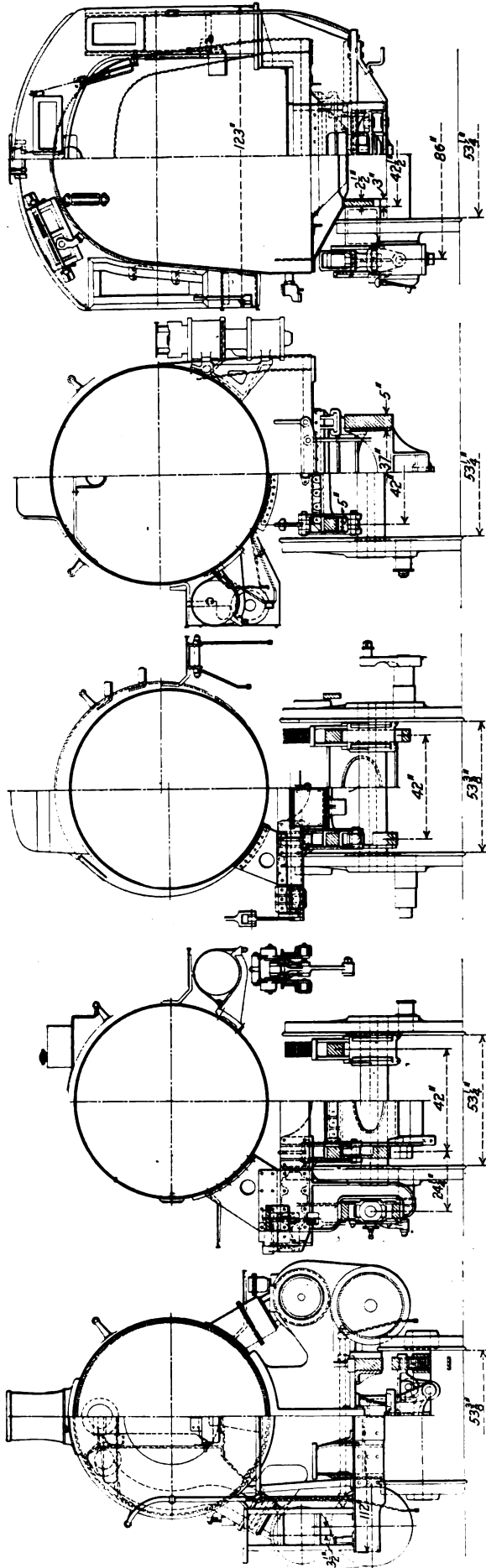

Elevation and Cross Sections of Santa Fe Simple Pacific Type Locomotive

and a pair of vertical keys. A substantial system of transverse frame bracing is applied. The guide bearer brace, which is a large steel casting, extends the full depth of the leading driving pedestals, serving as a fulcrum for the driving-brake shaft, and the valve motion bearer, which is located midway between the front and main driving pedestals, has a long bearing on the upper frame rail. A similar brace supporting a waist sheet is placed between the main and rear driving pedestals. A deep brace is also applied at the main pedestal and the frames are braced at the splices between the main and rear sections by a large casting which supports the front end of the firebox and carries the trailer truck radius bar pin.

The driving boxes are cast steel and are fitted with brass hub faces which bear against steel wheel centers. The shoe and wedge faces of the boxes are also lined with brass, while the shoes and wedges are cast iron. Flange oilers are applied to the main driving wheels. The trailer track is of the Rushton type with outside journals, a design that has been applied to a large number of locomotives built for the Santa Fe System.

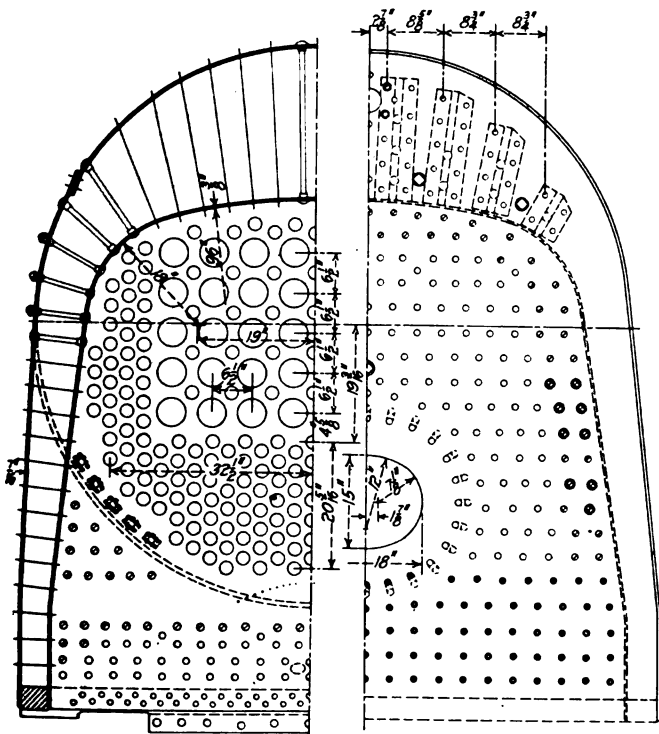

Cross Sections of the Boiler

The truck frame is composed entirely of steel castings and the swing links are of the three-point suspension type.

The tender has a water capacity of 10,000 gal., and carries 3,300 gal. of oil. The trucks are of the six-wheel Common-wealth type; this type is now in use under a large number of high capacity tenders in passenger service on the Santa Fe.

The principal dimensions and data are as follows:

General Data

Gage	4 ft. 8 1/2 in.
Service Fuel	Passenger Oil
Tractive effort	41,000 lb.
Weight in working order	288,700 lb.
Weight on drivers	172,550 lb.
Weight on leading truck	59,950 lb.
Weight on trailing truck	56,200 lb.
Weight of engine and tender in working order	506,000 lb.
Wheel base, driving	13 ft. 8 in.
Wheel base, total	35 ft. 3 in.
Wheel base, engine and tender	71 ft. 5 1/4 in.

Ratios

Weight on drivers ÷ tractive effort	4.21
Total weight ÷ tractive effort	7.04
Tractive effort × diam. drivers ÷ equivalent heating surface*	506.17
Equivalent heating surface* ÷ grate area	88.65
Firebox heating surface ÷ equivalent heating surface,* per cent	3.92

Weight on drivers ÷ equivalent heating surface*	29.18
Total weight ÷ equivalent heating surface*	48.82
Volume both cylinders	15.98 cu. ft.
Equivalent heating surface* ÷ vol. cylinders	370.02
Grate area ÷ vol. cylinders	4.17

Cylinders.

Kind	Simple
Diameter and stroke	26 in. by 26 in.

Valves

Kind	Piston
Diameter	16 in.
Lead	1/4 in.

Wheels

Driving, diameter over tires	73 in.
Driving, thickness of tires	3 1/2 in.
Driving journals, main, diameter and length	11 in. by 13 in.
Driving journals, others, diameter and length	11 in. by 13 in.
Engine truck wheels, diameter	34 1/2 in.
Engine truck, journals	7 in. by 12 in.
Trailing truck wheels, diameter	50 in.
Trailing truck, journals	8 in. by 14 in.

Boiler

Style	Extended wagon top
Working pressure	200 lb. per sq. in.
Outside diameter of first ring	80 in.
Firebox, length and width	114 in. by 84 1/2 in.
Firebox plates, thickness	Sides, back and crown, 3/4 in.; tube, 1/2 in.
Firebox, water space	Front and sides, 5 in.; back, 4 1/2 in.
Tubes, number and outside diameter	244—2 1/2 in.
Flues, number and outside diameter	40—5 1/2 in.
Tubes and flues, length	21 ft.
Heating surface, tubes and flues	4,211 sq. ft.
Heating surface, firebox	232 sq. ft.
Heating surface, total	4,443 sq. ft.
Superheater heating surface	980 sq. ft.
Equivalent heating surface*	5,913 sq. ft.
Grate area	66.7 sq. ft.

Tender

Journals, diameter and length	5 1/2 in. by 10 in.
Water capacity	10,000 gal.
Oil capacity	3,300 gal.

*Equivalent heating surface = total evaporative heating surface + 1.5 times the superheating surface.

CHARACTERISTICS OF PLATE SPRINGS*

BY GEORGE S. CHILES

PART I (Concluded).

The test curve of a double elliptic tender truck spring which had been exposed to the weather on the storehouse platform for some time is shown in Fig. 7, the ordinates in this instance showing the distance between the bands instead of deflection. While this spring has only five plates in each section, the friction reaches a maximum value of 6,000 lb. This brings out clearly the large influence which friction may have upon the action of springs, especially those on which rust has accumulated.

Test curves of a locomotive driving spring are reproduced in Fig. 8. Curve A was taken just after the spring had been removed from the engine and curve B after it had been reset, re-tempered and the plates painted with oil and graphite before assembling. The decrease in friction resulting from the reworking of the springs and the introduction of a lubricant between the plates is very pronounced. The deflection for a load of 26,000 lb. has been increased from 1.35 in. to 2.1 in. A slight irregularity is apparent in the upper portion of the release load curve before the spring was reset. This is of quite frequent occurrence and is considered of little consequence so far as it affects the general law of the performance of springs. The curves obtained from this spring are very similar to a number of others obtained under similar conditions from springs differing considerably in design, flexibility and friction, and may be considered as fairly representative of the effect of service on the action of locomotive driving springs. They show that the prevailing opinion that springs become more flexible after a period of service is not well founded.

This conclusion is also borne out by experience with passenger car bolster springs. One of two springs removed from a dining car which had been shopped on account of hard riding is shown in Fig. 9. As near as could be ascertained these springs had been in continuous service for four years and one month, during which time the car had traveled a distance of 380,119 miles. The car was equipped with wooden trucks, which were scrapped.

*Part I commenced on page 161 of the April, 1915, number.

The condition of the old springs, however, seemed to warrant replacing them in the new trucks without resetting. In accordance

and down to insure that the springs were working properly. Under this treatment the bolster springs showed no movement whatever, although the equalizer coil springs gave considerable movement. The springs were therefore removed from service and photographed. The reason for their stiffness is apparent from Fig. 9, which shows the extent to which rust had collected between the plates.

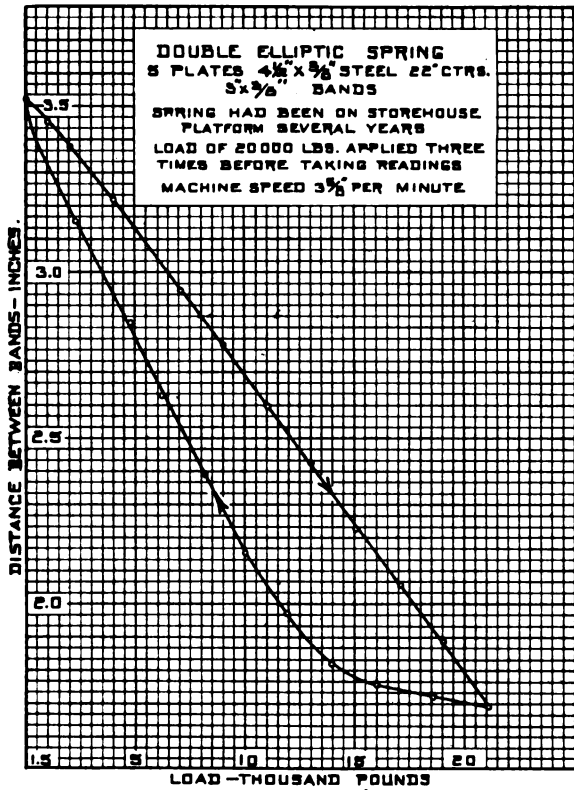

Fig. 7

with the usual practice at the shop in question several men, 16 in this instance, got upon the platform and jumped the car up

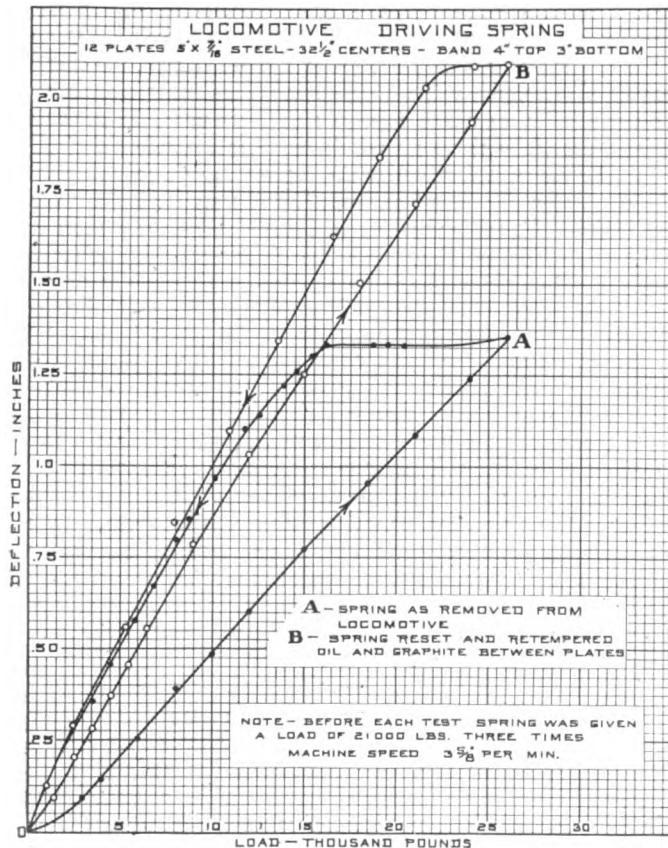

Fig. 8

SERVICE HEIGHT OF SPRINGS

Attention has been called to the greater uniformity of release load curves as compared with application load curves. In order

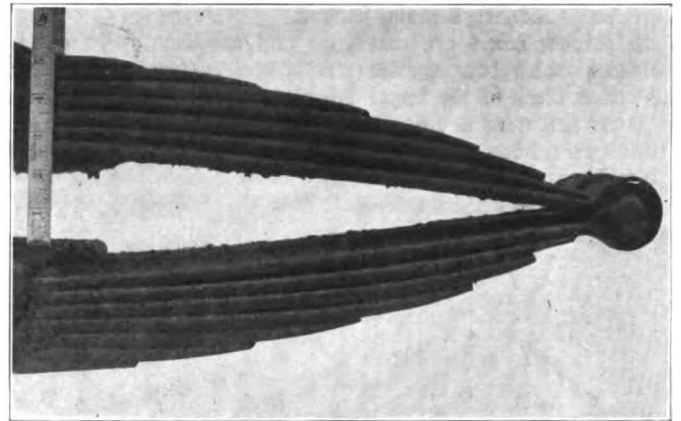

Fig. 9

to determine which curve is nearer the actual height of springs in service, a coach was selected at random; the load on the four springs accurately determined by weighing the coach and deducting the weights unsupported by the springs, and the height of each spring calipered. The springs were then removed and tested, the lower part of the curves being reproduced in Fig. 10.

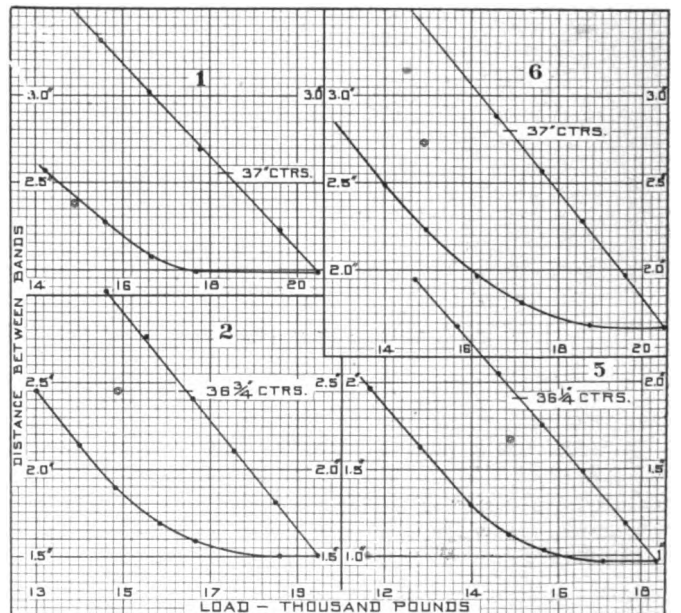

Fig. 10

The heights of the springs as calipered under the car are shown by the double circles, which are plotted for loads of 14,875 lb., the average load for the four springs. For curve 1 this point falls practically on the release load line. For curves 2, 5 and 6

the points fall between the two lines; the first two mentioned being slightly nearer the applied load line, while the latter is nearer the release load line. In a similar test on springs from a cafe car, the calipered loaded heights of the springs removed from the range side of the kitchen end of the car are on the release load line, while those for the springs from the passageway side of the same end of the car practically coincide with the applied load curve. That is, the springs from the range side ride lower than those from the other side, which fact may explain why car foremen often make it a practice to place heavier springs, or springs of greater height, under the range side of the kitchen end of a car. This had evidently been done, for these springs were similar in all other respects except that those under the range side had seven plates, while the others had six plates. In case a car is heavier in one corner, it would perhaps be advisable to provide for it in the design of the springs, otherwise they may ride low and possibly take a permanent set.

These curves seem to indicate that the working height of a spring under a static load falls about midway between the ap-

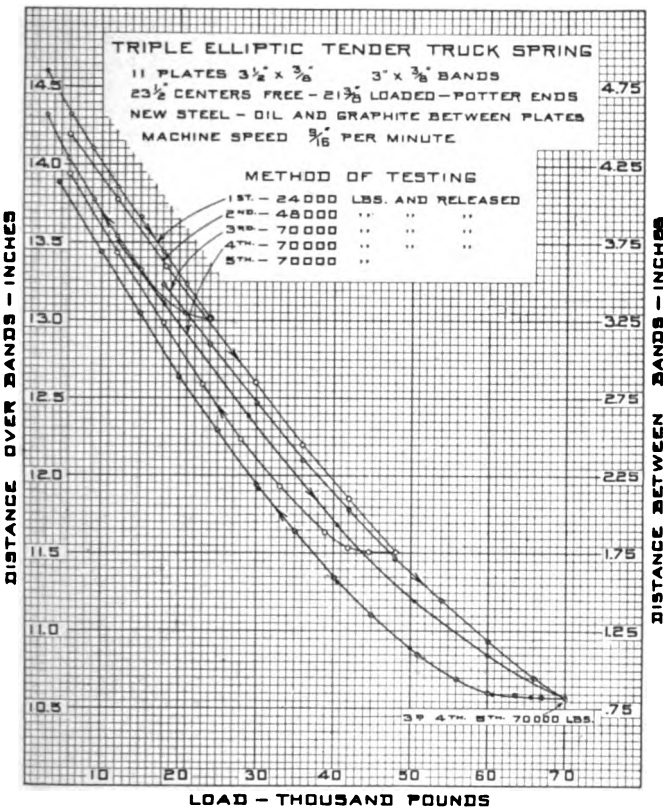

Fig. 11

plied and release load lines, favoring slightly the release load. Attention is called to the fact that the height of the springs was measured when the car was at rest. Doubtless when the car is in motion, the springs do not have the opportunity to adjust themselves that they do during the gradual retardation before the car stops, in which case the average running height probably approaches nearer to the release load curve. While the data relative to the service height of locomotive driving, trailing and tender truck springs is not complete, personal observation would seem to warrant the conclusion that these springs generally ride closer to the release load curve.

PERMANENT SET

Early in the article the fact was brought out that the free height of a spring is often reduced by the application and removal of the initial load. Assuming that the readings are free from error and neglecting the time effect, this reduction, often referred to as the initial set, may be due to either one or both

of two causes. The first is the internal friction existing between the plates. This results partly from the imperfect fitting or camber of the plates, and is sometimes brought about by the use of plates of different thickness in the same spring. In the course of carefully conducted experiments, it has frequently come under the observation of the writer that a spring, constructed in such a manner that only slight initial stresses are set up in the individual plates when the band is applied, will not exhibit as marked a difference as an improperly constructed spring. Frequently, the spring can be made to return to its original free height by jarring it or allowing it to stand undisturbed for some time. Secondly, this reduction in free height may be caused by one or more of the plates of the spring taking a permanent set. This condition is shown in the curves of Fig. 11, in which a triple elliptic spring was loaded to 24,000 lb., without previously having been limbered up. After the removal of this load, a second load of 48,000 lb. was applied, the heights for the various loads being measured. Upon the removal of this load, three successive loads of 70,000 lb. each were applied and removed. The applied load curves are approximately parallel, but at some distance from each other, this distance being quite appreciable for the 70,000 lb. load. These curves would seem to indicate that a slight permanent set resulted from the application of the second load, although it is possible that the spring had not yet become thoroughly limbered up. The same is true for the third load. As the applied load curves for the fourth and fifth loads coincide, but are somewhat lower than the applied load curve for the third load, with the exception of the final or 70,000 lb. point, it would seem that having taken a permanent set for the first load of 70,000 lb., the set was not appreciably increased when this load was repeated in the fourth and fifth tests.

As in the case of any material which develops defects under test, it is customary to reject springs that take any permanent set at a specified test load. Generally speaking, the method of procedure in testing springs is more or less a matter of personal opinion, and it is questionable whether in all cases permanent set is detected. One method of testing which is quite generally followed in railroad shops consists in first giving the spring a load varying from 125 per cent to 150 per cent of the static load. This preliminary load is applied from one to three times, three applications being ordinarily specified, the free height of the spring being recorded upon its final removal. The loaded height, which is then obtained will vary according to the manner in which the spring is loaded. In some instances the static load is specified while other specifications require that an overload be applied and then released to the static load. Inasmuch as these two readings will be found to vary considerably some specifications call for the average of the two readings as the height of the spring under the load. Finally, after this load has been removed, the free height of the spring is measured and compared with the free height after the removal of the preliminary load to determine if the spring has taken any permanent set. Now had the spring referred to in Fig. 11 been tested according to either of these methods, it seems fair to assume that the permanent set would have taken place under the first application of the overload rather than under its repeated application or the application of the lighter static load. Had the spring been first loaded to 70,000 lb., an overload of approximately 150 per cent, it is plain that it would have taken a permanent set under the first application, and since no additional permanent set took place when this load was twice repeated, it seems certain that it would not have done so under its fourth application, or a subsequent application of the lighter static load of 48,000 lb. If this is true then this method of testing springs for permanent set is not trustworthy and the unreliability of a reapplication of the final load as a check is apparent.

The following method of testing for permanent set is suggested. Knowing the static load for which the spring is designed and having determined upon an overload, of say, 50 per cent of this static load, first, subject the spring to a load of 75

box shows the shape to which the side sheet is bent in order to permit a satisfactory connection between it and the lower ends of these water tubes, the bottom row of which is about 15 in. above the mud ring at the front end. The tubes are spaced at 4 in.

joint in the two sheets is shown in the drawing of the boiler cross sections, but in this instance the water tubes are not welded in as shown on the drawing. Instead they are prossered, belled and beaded and set without ferrules in the top sheet, while the

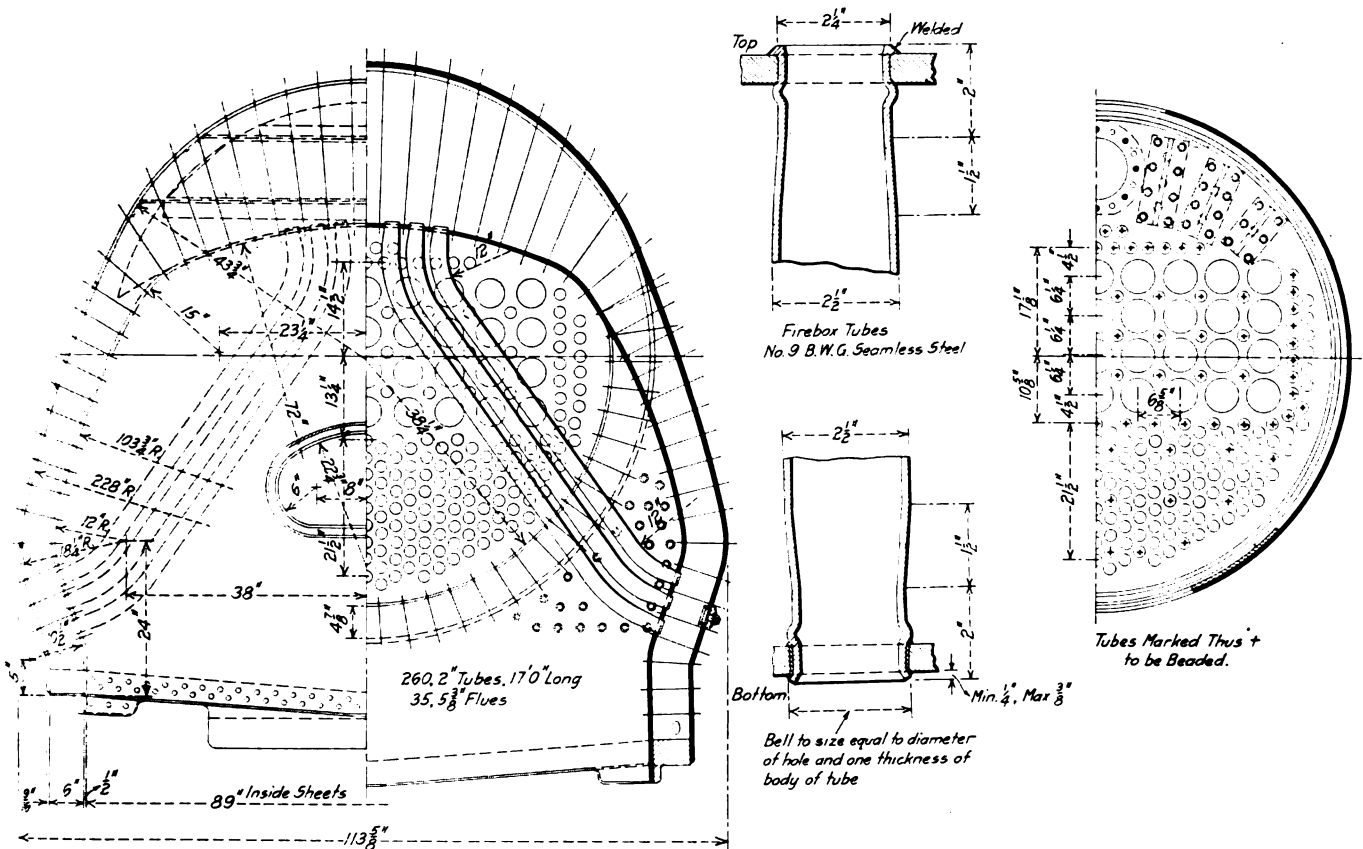

Cross Section Showing the Arrangement of the Tubes in the Firebox; In this Engine the Tubes Are Not Welded as Indicated

centers and swing upward across the firebox space to the crown sheet, in which the ends are inserted. Plugs for cleaning purposes are placed opposite the ends of the tubes in the outer shell sheets, both top and bottom. The method of securing a tight

bottom ends are set with a ferrule, prossered, expanded and belled. These tubes are made of seamless soft steel, tested to 2,000 lb. per sq. in. hydraulic pressure before application.

The water tubes give a heating surface of 471 sq. ft., the total

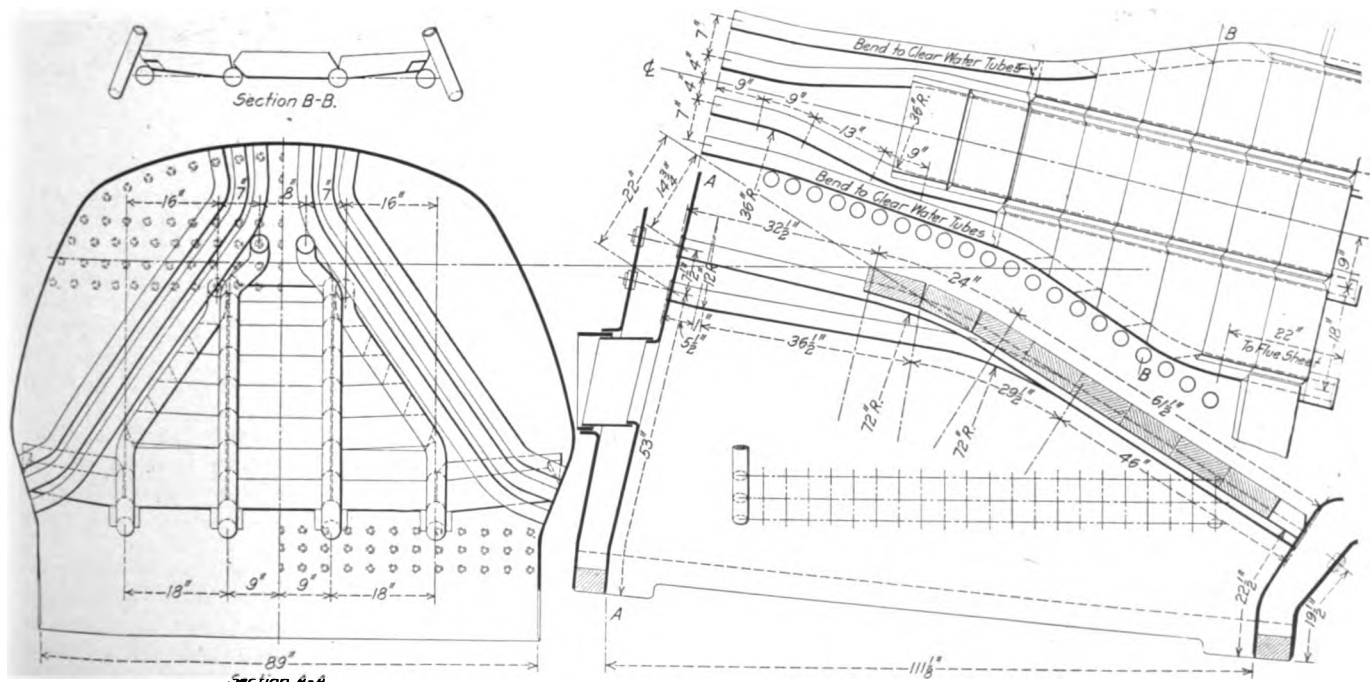

Brick Arch Arrangement Used In the Water Tube Firebox

heating surface of the boiler being 494 sq. ft. greater than that of other locomotives of the same class. The total heating surface for the engine with the experimental boiler is 3,960 sq. ft., while that of the sister locomotives is 3,466 sq. ft.; this does not include the superheater surface of 740 sq. ft. In the experimental engine the heating surface of the firebox and combustion chamber is 288 sq. ft., while that of the other engines of the same class is 267 sq. ft.; the tube heating surface for the experimental engine is 3,177 sq. ft., the same as that of the sister engines. A special application of the Security brick arch was made to the water tube firebox.

The object of the water tube construction was to obtain an improved circulation by providing definite cycles of circulation through these tubes in the zones of greatest heat intensity as well as to locate the heating surfaces to greatest advantage. While the locomotive has not so far been in service long enough to permit of any definite results being obtained, the performance has been so satisfactory with both bituminous and anthracite coal that the Lackawanna has ordered another engine fitted with this boiler, for use exclusively in fast passenger service. Considerable valuable information has been obtained showing its performance in comparison with the sister engines; further tests are being conducted, and it is expected at a later date that interesting performance data will be available.

A few of the principal dimensions of the locomotive are given in the following table:

Class	4-6-2
Gage	4 ft. 8½ in.
Diameter of driving wheels.....	69 in.
Tractive effort	43,200 lb.
Cylinders	25 in. by 28 in.
Weight on leading truck.....	50,000 lb.
Weight on drivers.....	189,600 lb.
Weight on trailing truck.....	58,000 lb.
Total weight of engine in working order.....	297,600 lb.

GOOD FEATURES OF TENDER TANK DESIGN

BY WALTER R. HEDEMAN

Much attention is being given to the effect of locomotive detail design, both upon the cost of maintenance and the convenience of operation. The opportunities for improvement are not confined to the locomotive itself; tender tanks are a source of considerable trouble in the shop and on the road, which, partially at least, may be eliminated. It is the purpose of this arti-

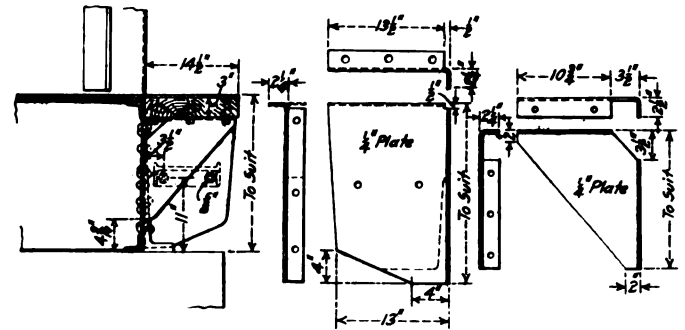
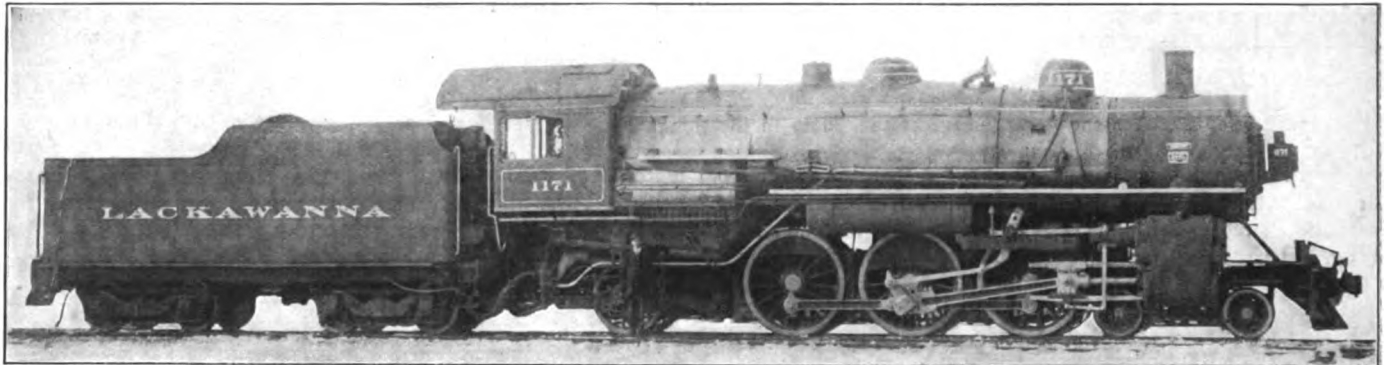

Fig. 1—Pressed Steel Tank Deck Supports

cle to describe a number of features of design which have proved valuable in reducing tank troubles and facilitating the making of proper inspections and repairs.

Where the tank and tender frames are of separate construction it is generally the practice to support the tank upon a wooden floor. If the floor is laid solid it is necessary to lift the tank



Lackawanna Pacific Type Locomotive, the Boiler of Which Has a Water Tube Firebox

Coal capacity of tender.....	10 tons
Water capacity of tender.....	9,000 gal.
Total weight of tender loaded.....	165,500 lb.
Total weight of engine and tender.....	463,000 lb.
Rigid wheel base	13 ft.
Wheel base of engine.....	33 ft. 10 in.
Wheel base, engine and tender.....	66 ft. 4 in.
Boiler pressure	200 lb.
Grate area	69 sq. ft.
Diameter of boiler.....	78 in.
Firebox	89 in. by 111 in.
Factor of adhesion.....	4.39
Water tubes, diam., gage and length, 2½ in., O. D.; seamless steel, No. 9; 6 ft. average	
Heating surface, firebox and combustion chamber.....	288 sq. ft.
Heating surface, water tubes.....	471 sq. ft.
Heating surface, fire tubes.....	3,177 sq. ft.
Heating surface, arch tubes.....	24 sq. ft.
Total heating surface of firebox.....	783 sq. ft.
Total heating surface.....	3,960 sq. ft.
Superheater heating surface.....	740 sq. ft.

PANAMA CANAL TRAFFIC.—During the first six months of its operation, 496 vessels were handled through the Panama Canal. These vessels carried a total cargo tonnage of 2,367,244, on which the tolls amounted to \$2,126,832. A press despatch from Panama says that up to April 1, the tolls have amounted to \$2,894,300, and that the total cost of operation and maintenance during the same period was \$3,020,000, leaving a deficit of \$125,700.

from the underframe in order to locate and repair leaks which develop in the bottom sheet. It will be found of great assistance in making repairs between general shoppings of the engine to have the boards spaced from 6 in. to 9 in. apart, the rivets in the cross seams being located above the spaces, where they are readily accessible for calking. The length of the boards should be considerably shorter than the tank in order that access may be had to the rivets and seams along the side of the tank. Both the amount of tank leakage and cost of maintenance have been reduced since this practice was adopted.

Fig. 1 shows a type of tank deck support which is durable and simple in construction. These supports leave the front of the tank open for inspection below the deck and prevent the accumulation of fine coal against the tank sheets, which causes corrosion and wasting of the sheets.

Another means by which the cost of tank repairs may be reduced is shown in Fig. 2. In water bottom tanks the bottom of the coal pit is covered with a ¼-in. plate, resting on ¾ in. by 1½ in. spacing strips. It extends forward from the slope sheet seam to the front of the tank deck, to which it is secured by lag screws. It protects the water-bottom roof sheet from wear,

and when worn out its renewal is an easy matter compared to the laborious operation of renewing or patching the tank sheet.

With the usual form of tank manhole, it is a difficult matter in making water stops to accurately spot a locomotive hauling

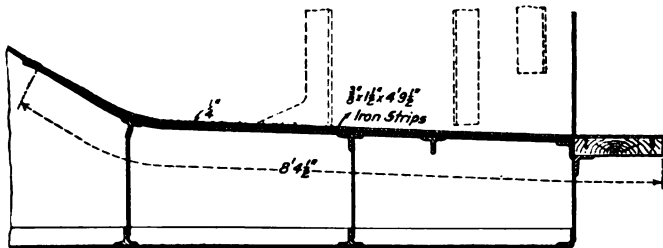

Fig. 2—False Shovel Sheet

a heavy passenger train. It is frequently necessary to stop with a suddenness that is very disagreeable to the passengers. Fig. 3 shows a manhole designed to increase the range within which

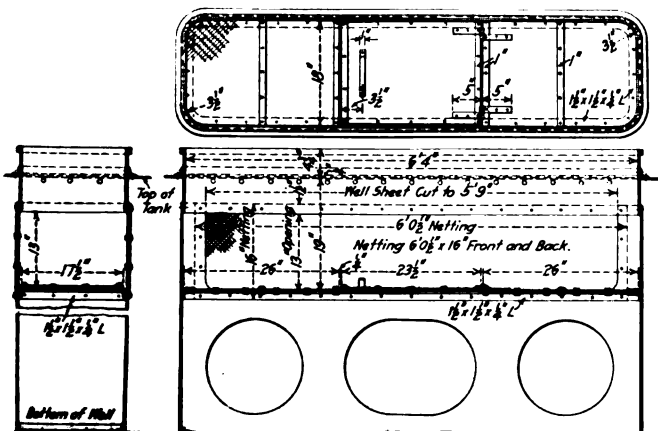

Fig. 3—Long Tank Manhole with Enclosed Well

service from the water crane may be secured. It is 18 in. wide by 6 ft. 4 in. long and permits the engine crew to reach the water crane anywhere within a distance of about 10 ft. The large

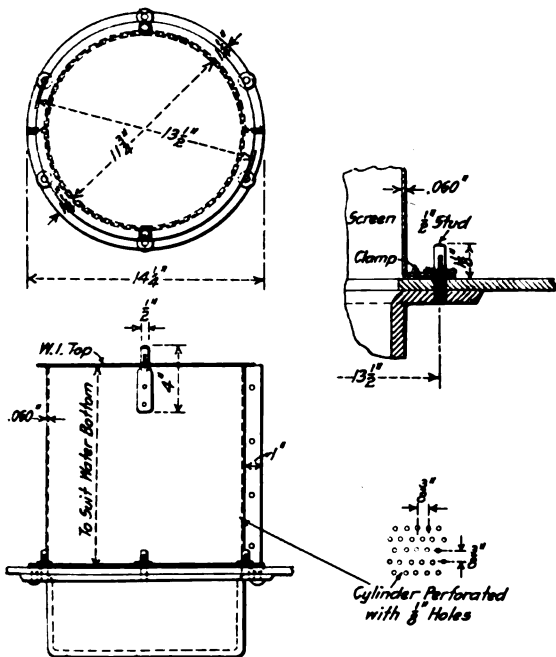

Fig. 4—Tank Strainer Used with Outside Tank Valve

tanks of modern passenger locomotives extend back of the coal space for a sufficient distance to permit the use of this construction. The manhole sheets extend from the top to the bottom of the tank, the sides being cut away for a depth of 13 in. from

a point about 6 in. below the top. The openings thus formed are covered with 2½ in. by 2½ in. wire mesh, a screen of the same mesh being placed across the well below the openings. The large holes shown in the walls below the screen are located about midway between the top and bottom of the tank. The bottom of the well forms a trap for sediment which passes through the screen; it has been found that considerable hard matter accumulates at this point. The horizontal screen is made in three sections, which are readily removable for cleaning out the bottom of the well. The cover of the manhole is also made in three sections in order that each part may be easily handled.

While the well below the manhole accumulates a large amount of fine material which would otherwise enter the tank, it has

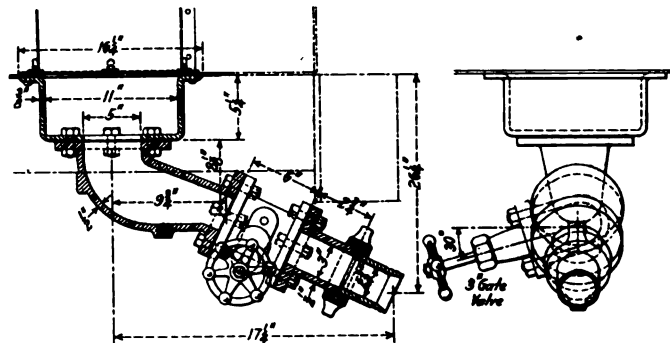

Fig. 5—Outside Tank Valve

been found desirable to cover the tank well with the strainer shown in Fig. 4, as an additional protection to the injector from small particles of coal which may be carried through to the tank. With an outside tank valve this strainer can be made exceptionally tight. No provision is required through the top for the passage of the tank valve rod; the only openings are the ⅛-in. perforations through the cylinders.

Tank valves operated from the deck by means of a rod extending up through the tank, have been a source of much trouble on water-bottom tanks. Unless the tank is built with a well surrounding the rod, a packing gland is required where the rod passes through the water-bottom roof sheet, and considerable trouble is experienced in keeping this tight. The valve is inaccessible and can be given very little attention. With a gate valve applied outside of the tank, as shown in Fig. 5, very good results have been obtained. The valve is accessible and can be readily packed; when open it offers an unobstructed passage.

TESTS OF LUBRICANTS

BY H. M. BAXTER

In large plants, where a chemist is constantly employed, the testing of lubricants, together with all other materials, is common practice. For smaller shops, where constant testing is rendered impracticable owing to the expense and time involved, it is necessary to purchase ready-to-use lubricants, or, where economy is required, the pure natural products. The latter course, while more economical and far superior to using the cheaper prepared products, is one that requires some knowledge of the qualities required in the lubricant to best meet the conditions of various classes of service. In judging the purity and usefulness of oil, the practical analyst usually makes eight different tests. While no attempt is made to give in detail the methods of conducting these tests, the writer believes that the following general outline of the points to be investigated may be of help to those who are interested in lubrication.

The first test is for specific gravity, which may not necessarily be of paramount importance in itself, but is invaluable as an eliminating test. For instance, pure sperm oil has a specific gravity of 0.883, and while the specific gravity of some other oils or mixtures may possibly be the same, any other degree

instantly stamps the same as impure and the test need be carried no farther. The second test is made with the aid of alkalies, which clearly show whether the sample is pure, fatty (of either vegetable or mineral origin), hydrocarbon (mineral), or a mixture of both. This information is of great value owing to the varying degrees of spontaneous combustion possessed by the several grades of oil, which property should be carefully considered. The third is the sulphuric acid test giving the true color value in determining the source of fatty oils.

The free acid test is fourth and is one of the most important, as a very small proportion of free acid will attack the bearing metal, this action being especially severe on copper or brass. An oil containing a fraction of 1 per cent of free acid will dissolve sufficient brass within a few hours to take on a decidedly greenish tint. The fatty vegetable oils usually possess free acid, ranging from a fraction of 1 per cent to a considerable proportion of their bulk, and as they become rancid the free acid increases. Properly refined mineral oils do not carry any free acids, nor do they develop any with age or exposure.

The fifth test is for viscosity, or body. The old fashioned axle grease, thick as cold butter, was extremely high in viscosity, while the many modern trade-marked oils, which are invariably light mineral oils, recommended for general use on sewing machines, oil-stones, etc., are almost as thin as water with a correspondingly low viscosity. The correct degree of viscosity depends upon the use for which the oil is intended. Heavy or fast running machinery requires a heavy, thick oil, whereas a delicate mechanism requires a thin, light oil. The sixth is the flash point test, which determines the effect of heat upon the oil. This includes the determination of the dangerous spontaneous combustion, or flash point as well as the unpleasant vaporizing, or smoking point. The temperature at which an oil will flash is often used as an indication of its viscosity or body, it being much easier to make the flash test than to directly determine the viscosity. This is based upon the assumption that the more body an oil possesses, the higher the temperature required to give off inflammable gases. This test also has a direct bearing on the tendency of the oil to gum, as it is the oxidization of the oil which causes it to assume a gum-like consistency. Seventh is the evaporation test. No good lubricating oil should lose more than one-quarter or one-half of 1 per cent of its weight when subjected for several hours to a temperature of approximately 212 deg. Fahrenheit. A good cylinder oil subjected for several days to a constant temperature of 350 deg. Fahrenheit, should not lose over 5 per cent in weight.

An eighth test is sometimes made with acetic acid to ascertain the temperature at which an oil will lose its clearness and become muddy or turbid. While this is not of vital importance it is of interest when choosing the better of two nearly equal oils, as a clear oil is more desirable than a muddy one. The essential requirements of a successful lubricant will be determined by the first seven tests.

FEED WATER HEATER USED ON GEARED LOCOMOTIVES

BY HAROLD S. JOHNSON

The accompanying engravings show a type of front end feed-water heater used on the Shay geared locomotives of the Tamalpais and Muir Woods Railway in California. There are five locomotives fitted with this type of heater and it has been in use on this road for over ten years, with satisfactory results.

The heater consists of a cast iron header *H* which rests on legs directly over the exhaust nozzle *E*. The header is divided into two compartments; the lower compartment is tapped to accommodate 16— $\frac{3}{4}$ in. tubes and the upper compartment is tapped to accommodate 16— $1\frac{1}{2}$ in. tubes. The $1\frac{1}{2}$ in. tubes have plugs welded in their upper ends, squared on top so that the tubes can be easily applied and removed by the aid of a

socket wrench. The ends of the $\frac{3}{4}$ in. tubes are open and these tubes terminate several inches below the ends of the $1\frac{1}{2}$ in. tubes.

After leaving the injector the water passes through $1\frac{1}{2}$ in. pipe *A* to the lower compartment of the header, thence up through the $\frac{3}{4}$ in. tubes and down through the $1\frac{1}{2}$ in. tubes as indicated by the arrows, after which it passes out of the header and into the boiler through connection *B*. The hot gases passing up through the stack heat the water circulating through the heater. In a recent test on a locomotive pushing one light car

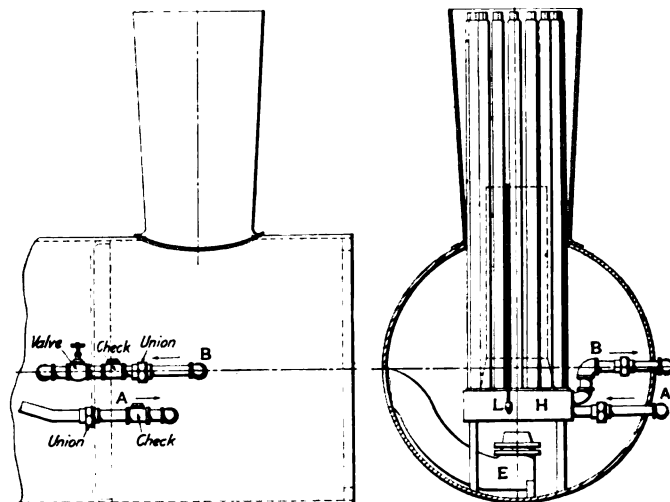

Arrangement of Feed Water Heater Used on a Shay Geared Locomotive

up a 7 per cent grade it was found that the average temperature of the feed water, after leaving the injector and before passing into the heater, was 184 deg. In circulating through the heater the temperature was maintained at 204 deg., making a rise in temperature of the feedwater of 20 deg. With a load consisting of three of the light cars in use on the Tamalpais road the feed-water temperature after leaving the heater was maintained at a temperature of 230 deg., making a rise in temperature of 46 deg.

The locomotives equipped with this heater use a good quality of water and no trouble is ever experienced with scale. The

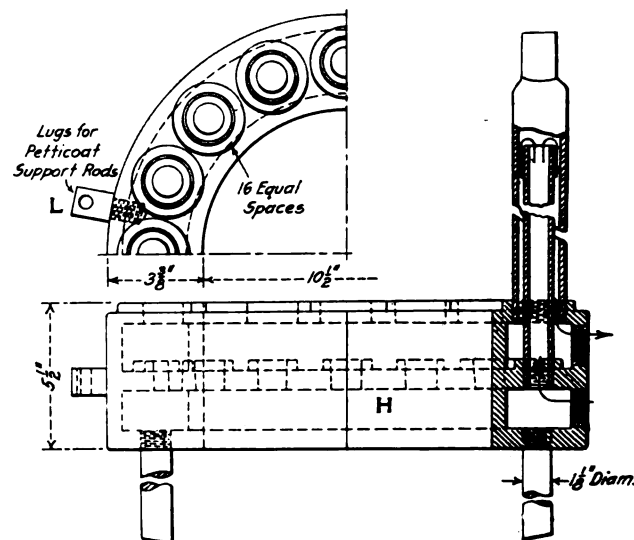

Details of the Feed Water Heater

only trouble ever caused by these heaters is the tendency of the water to eat away the bottoms of the tubes, but this can largely be done away with by the use of a better quality of tube. Common black pipe is used in the heaters at present. The life of a set of tubes is from four to five years, with one or two re-threadings of the ends on account of the action of the water.

CAR DEPARTMENT

CONSIDERATIONS AFFECTING THE TYPE OF CENTER SILLS IN STEEL PASSENGER EQUIPMENT

BY L. K. SILLCOX

Assistant Mechanical Engineer, Canadian Northern, Toronto, Ont.

The writer recently had occasion to discuss the question as to whether built-up fishbelly or rolled steel center sills are preferable for use in conjunction with a steel side construction. Apart from any personal opinion, it is believed that consideration should first be given to the matter of weight per lineal foot of car body, assuming, of course, an ample factor of safety in the structure to meet operating conditions as encountered in general.

In determining on the design of a steel car, there should first of all be taken into account past practice in wooden car construction. The wooden car which is being discarded today is the result of many years' refinement in design and possesses many requirements which it would be advisable, if possible, to duplicate in steel construction. One of the reasons for the remarkable performance of the wooden car in resisting all but destructive impact forces, is its flexibility. No metal underframe of any type can ever give satisfaction unless there is a proper regard for flexibility in the design; if this is not present there is nothing that will absorb impact shocks and disseminate buffing strains. It is also unreasonable to expect to obtain a maximum factor of safety in the car itself or even obtain a reasonable service from couplers and draft attachments, unless a high capacity draft gear is provided. It is required in the designing of postal cars that 400,000 lb. be assumed as the shock necessary to be absorbed. The United States Railway Mail Service department acted conservatively in deciding upon this figure, since it has been found in several tests that shocks may be as high as 600,000 lb. or more.

The center sills in a car are in compression when performing their most difficult function. The strength of any construction in compression depends on the uniformity of the material, the arrangement of the section, the unit cross sectional area, and the length between supports. The center sills form a beam supported at two points, and having overhanging ends and have to be arranged to resist buckling or crushing due to the load of 400,000 lb. already mentioned. In a steel beam or column designed to absorb this impact force, considering 28,000 lb. per sq. in. to be the elastic limit of the steel, the minimum area required would be $400,000 \div 28,000 = 14.28$ sq. in.

The height from the track to the center of the coupler is determined by law and the customary height of the floor above the coupler is regulated by the required height of platform buffers. In general, this is 16 in. above the center of the coupler. In wooden car construction the center sills are shallow and the coupler is supported below them. Loads upon the underframe brought about by buffing tend to bend down the ends of the car, due to the fact that it is impossible to provide camber at the center of steel center sills without allowing it to take a natural slope to the extreme end of the center sill structure; that is, practice has proved the impracticability of trying to mechanically secure the camber in the sills, so as to have the portion from the bolsters to the end of the car come parallel with the rail.

The ideal underframe should have all members join each other in the same plane, so as to prevent buckling due to eccentric loading; each member should also be designed to perform its individual functions, passing the stresses from

one member to the other. The central portion of any underframe is exposed to receive initial impacts on account of the prevailing design of convex end, which is necessary in order that equipment may properly clear on curves when coupled in trains. This portion should therefore be made strong enough to take the greatest buffing shock assumed to be encountered in service. As has already been shown, the underframe receives the force of end collision as a column load on its longitudinal members, while the end frame receives it as a transverse load on its exposed members. Under these circumstances it is obviously impracticable to make the end frame equally strong with the underframe; furthermore, it is evident that provision ought to be made to protect the end frame from destructive forces. A strong side construction is admittedly a valuable asset in providing additional end frame protection. In designing an end frame it has been the writer's practice to assume it to be a beam supported at its upper and lower ends and loaded at a point 18 in. above the car floor line, as it is generally considered that in case of two cars tending to telescope the point of maximum shock is never above this point. Connections are provided between the end frame and the remainder of the car frame of sufficient value to develop the full transverse strength of the end frame; the vertical members of the latter are connected by horizontal members so that in case the end frame is loaded to destruction the connections are sufficient to separate all the longitudinal members of the car frame and when they yield all parts will be forced toward the center at the end of the car, thus affording a maximum of resistance to any telescoping action between adjoining cars in a train.

There are some rather important functions which the underframe is called upon to perform. Not only must it sustain the weight of the superstructure and load (this embodies only that portion from a point about 12 in. inside the bolster, to the end, for shallow sills), but it must withstand impact, oscillating and pulling strains without distortion. Were it not for these conditions the underframe might be considered as a steel span resting upon the center plates. The design must also be reasonable with respect to material forming the frame, without excess weight, in addition to being strong enough to resist compressive strains of large magnitude.

A careful analysis of the prevalent systems of passenger car underframe design will be found of material help in deciding the best construction for any given case. Generally speaking, there are four theories of design now in practice and in order to properly present the subject, there are shown five designs for cars actually in service covering these four classes, and one additional showing the present practice on the road with which the writer is connected. The four types of design are:

1. Underframe designed to carry the whole weight on the center sills only.
2. Underframe designed to carry the whole weight on the center sills with a sustaining side girder.
3. Underframe designed to carry the load equally distributed on side and center sills.
4. Underframe designed to carry pulling and buffing loads only.

The first type has reference to a construction where deep center sills are used in conjunction with a light side girder, as shown in Fig. 1. Most underframes, of this type now in service are built with cast steel end portions which include in one casting the body bolster, platform, side and center

sills extending as far back as the bolster. This design of framing requires very deep sills, which represent additional weight over that necessary for any other type. Unquestionably the lightest car designed to uniform specifications as to strength would not be found among this first class. This additional weight does not mean an extraordinary increase, as from direct comparison it would appear not to exceed 4,000 lb. per car under usual circumstances, but on account

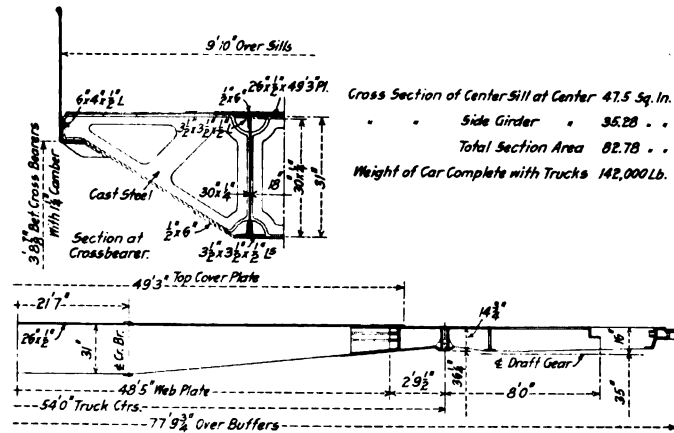

Fig. 1—Underframe with Deep Center Sills and Light Side Girders

of the necessity of the center framing having to sustain its own weight and that of the entire superstructure without deflection on a long span, it is necessary to use too much metal to be economical. With this style of framing, it is possible to secure a center line of draft coinciding with the neutral axis of the center sill at the center of the car. The stress per square inch on the center sills, due to any assumed maximum force of impact, would be equal to this force divided by the area of the section to be analyzed. Where such deep sills are used, it sometimes happens that the neutral

Gross Sectional Area at Center, Center Sill	42.61 Sq. In.
Side Girder	28.36
Total	70.97
Draft Gear	27.25
Light Weight of Car with Trucks	139,000 Lb.

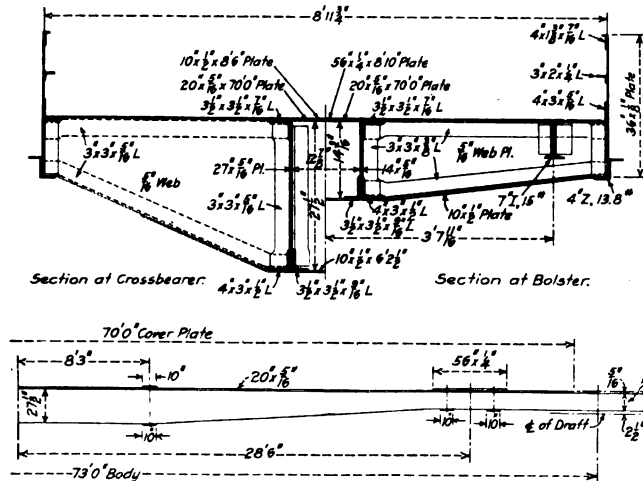

Fig. 2—Underframe Designed to Carry the Weight on the Center Sills, with a Sustaining Side Girder

axis of the section will come above the center line of the coupler, which adds to the total combined compression. This fact has helped to discourage the use of a framing like this.

In dealing with the second type, it can be stated that its greatest value appeared to be established during the period of the composite car; in fact, it is widely used at the present time for such construction. By referring to Fig. 2 it can be readily seen how the members naturally adapt themselves to

the application of wooden side framing. Many of the features common to the wooden underframe are discernible. This style of framing is somewhat lighter than that just considered. It served its purpose fairly well and did not affect the old style wooden side framing to any great extent, except in the replacing of the usual diagonal bracing by side blocking with straight planking.

In considering the third class, where it is assumed that the side and center sills sustained an equal share of the total vertical loading due to weight of construction and equipment appliances, the construction shown in Fig. 3, which is employed by one of the large car builders, has been selected. As an elementary consideration, an evenly distributed load is assumed over the entire length of the sills, and in the calculations only that portion of the load which comes between the truck centers is considered. The effect of the overhang

Gross Section of Center Sill at Center	47.073 Sq. In.
Side Girder	31.14
at Center Total	78.213
Draft Gear	35.66
Weight of Car Complete with Trucks	141,000 Lb.

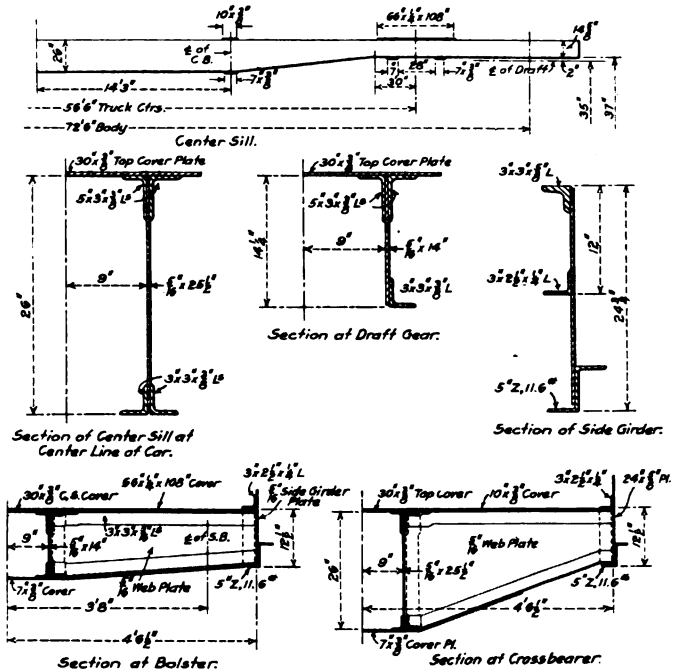

Fig. 3—Underframe Designed to Carry the Load Equally Distributed on Side and Center Sills

is neglected, which, if taken into account, would reduce somewhat the fiber stresses obtained at the center of the car. The section moduli of both side and center sills are generally combined to arrive at the maximum stresses produced by the loading. This is based on the assumption that there is no connection between the center sills and the side girder, but it would not seem unreasonable to assume that the cross-ties, bolsters and end sills tie these members together in such a way that we obtain far more strength from them together than we apparently obtain by adding the strength of the two members; that is, if we consider the steel in the side girder and center sills as one member and take the center of gravity of the entire structure, a much higher section modulus would be obtained than under the system named above, resulting in a considerably lower fiber stress. For a construction such as that under consideration, assuming truck centers 56 ft. 6 in. apart, it is reasonable to suppose that if the girder is designed to take care of the load for this distance, there ought to be no question of having a large margin of safety for any buffing stresses that might develop.

A rather large proportion of the all-steel cars built recently

are fitted with deep center sills. There is probably some good reason for this, but it is the writer's object to show some good reasons for the use of a shallow center sill. Undoubtedly, the point of chief interest centers around the question of weight. The writer has not been able to find a single case where any decrease in weight was obtained from a car having a steel side construction in conjunction with a fishbelly underframe, as compared with the same class of car with channel center sills. The following table is based on actual weights covering several styles of recent construction:

Class of car	Design of underframe	Light weight of body, lb.	Light weight per lineal ft., lb.
Baggage.....	Fishbelly	76,160	1,268
Baggage.....	Fishbelly	94,160	1,298
Baggage and Postal	Fishbelly	103,500	1,478
Baggage.....	Fishbelly	90,580	1,298
Baggage and Postal	Fishbelly	79,800	1,330
Baggage and Postal	Fishbelly	82,640	1,377
Baggage.....	Fishbelly	83,400	1,264
Baggage.....	Channel	91,360	1,260

It is not to be denied that there are advantages to be derived from the use of fishbelly underframes, but for a car having steel side construction it is not believed by the writer

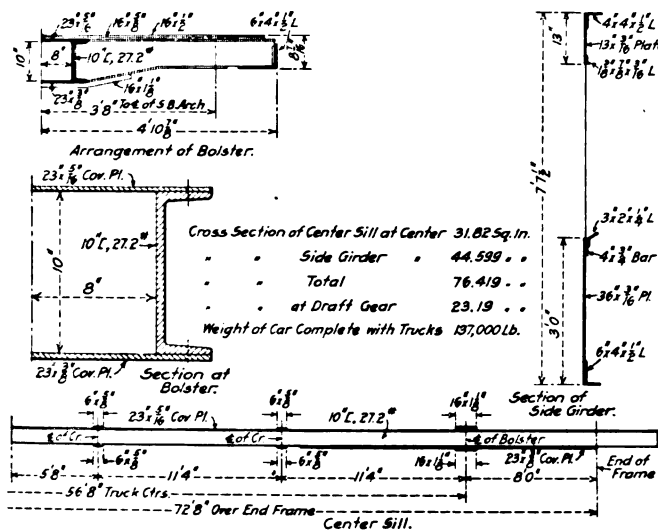

Fig. 4—Coach Underframe with Channel Center Sills

to be best. The foregoing table deals only with blind end equipment: Fig. 4, however, illustrates the present practice for coaches of one of the large roads and this car is also referred to in the last line of the following table:

Class of car	Design of underframe	Light weight of body, lb.	Weight per lineal ft., lb.
Coach.....	Fishbelly	103,040	1,467
Coach.....	Fishbelly	101,920	1,456
Coach.....	Fishbelly	97,000	1,338
Coach.....	Fishbelly	103,000	1,411
Coach.....	Channel	97,000	1,329

The cars referred to in this table are all in operation and an analysis of the sections considered shows that no matter what view the designer has taken of the subject, practically the same total number of square inches of material is provided in each case, with a slight showing in favor of the channel underframe type. We must, therefore, conclude that any advantage which one design is believed to have over another is the result of practical reasoning.

The operating man appreciates a construction where ease of inspection is possible, which certainly is not true of the fishbelly underframe; neither does this type lend itself easily to the application of electric lighting apparatus on account of the absence of sufficient clearance at the truck end sill. The structure is more or less weakened by having to be cut for the necessarily large number of pipes, conduits and levers unless additional metal is provided around the openings for reinforcement. It is very difficult to apply steam heat drips at the crossover and to apply rods and piping in the center of the car. The sills have to be spread at least 18 in. apart

if top inside flange angles are used, to enable the structure to be riveted up, as the rivet bucker cannot be accommodated in less space than this.

Great care is necessary to secure the proper camber for fishbelly underframes. For instance, the design in Fig. 2 has the camber provided for differently from that in Fig. 3. In Fig. 2 there is 3/4 in. camber in the top angle only of the center sill; the plate runs straight with the top and bottom edges parallel to the rail. The rivet gage in the top angle is 2 1/4 in. for the entire length, starting 2 1/8 in. down on the web plate at each end and rising to 1 3/8 in. at the center of the car. In Fig. 3 there is a 3/4 in. camber in the top angle only; the plate runs straight with the top and bottom edges parallel to the rail. The rivet gage in the top angle is 2 in. for the entire length, starting 1 7/8 in. down on the web plate at each end and rising to 1 1/8 in. at the center of the car. In both cases, 1 1/4 in. camber is provided in the side girder.

To secure a permanent camber in cars having shallow center sills is simply a matter of providing good workmanship and having the rivet holes true to gage and the rivets well driven. This is one of the secrets of this type of frame where top and bottom cover plates are used and it accounts for fully half the deflection occurring when a car is in the course of construction. It is usual to provide about 1 1/2 in. camber at the center of the side frame and center sills in this type of construction, which results in a minimum 3/4 in. finish camber when the car is complete.

Again referring to the wooden car, the last design built for

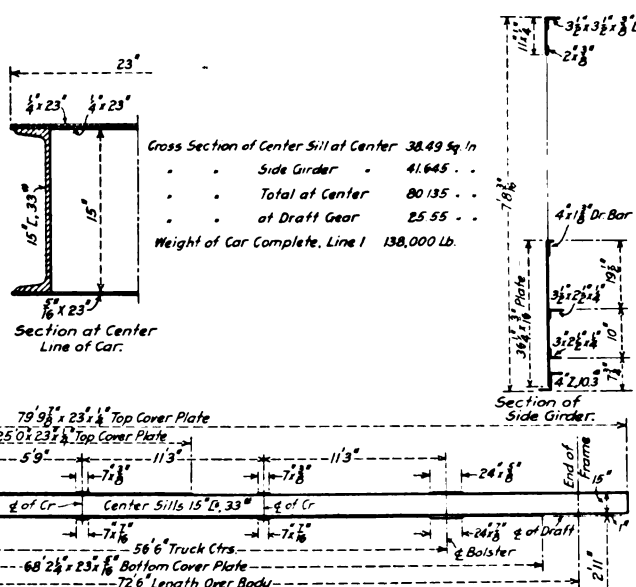

Fig. 5—Underframe Used on the Canadian Northern

the company with which the writer is connected was fitted with four 5 in. by 9 in. wooden sills, so located as to be nearly uniformly affected by end strains. There was a total cross sectional area of 180 sq. in. in this section with a section modulus of 270, the center of the draft gear being 11.5 in. below the neutral axis of the section. Based on a 400,000 lb. buffing shock with 150,000 lb. absorbed in the draft gear we have

$$\frac{250,000 \times 11.5}{270} = \frac{2,875,000}{270} = 10,649; \quad \frac{250,000}{180} = 1388.$$

Adding, this gives 12,037 lb. per sq. in. fiber stress. Considering the design shown in Figs. 5 and 6, which is a steel construction having 38.49 sq. in. area with a section modulus of 103.13, there being a drop of 8.5 in. between the draft gear center line and the neutral axis, we have

$$\frac{2,125,000}{103.13} + \frac{250,000}{38.49} = 27,300 \text{ lb. fiber stress.}$$

It is now the usual practice to use elastic limit as a basis

in comparing the relative value of steel and wood in car construction. The elastic limit of open hearth steel ranges close to 28,000 lb. and that of B. C. fir, such as is used for sills,

averages 6,400 lb.; we then obtain a ratio of $28,000 \div 6,400 = 4.4$. This is pointed out to sustain the contention that the stress shown for steel center sills is safe. The method of calculation does not take into account anything but absolutely maximum conditions. If the whole buffing shock were taken on the buffers we should have $400,000 \div 38.48 = 10,400$ lb. per sq. in. at the center and $400,000 \div 25.55 = 15,700$ lb. at the ends of the car, which gives a ratio of $15,700 \div 400,000 = 0.039$.

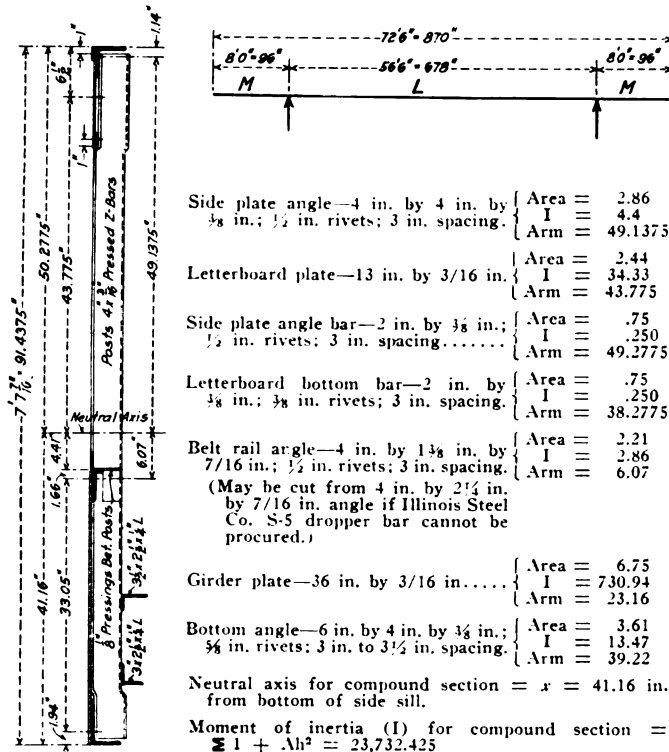

Bending moment at center of car, neglecting overhang which would reduce F. S. (Assume all load carried by side framing):

Estimated light weight of car body 72 ft. 6 in. long	= 103,000 lb.
Estimated weight of passengers and equipment	= 9,000 lb.
Total weight	= 112,000 lb.
Load per side	= 56,000 lb.
Load per unit length — 56,000 lb. ÷ 870 in.	= 64.36 lb.

$$M = W \left(\frac{l^2}{8} - \frac{M^2}{2} \right) = 64.36 \left(\frac{678^2}{8} - \frac{96^2}{2} \right) = 3,401,487.9$$

Maximum fiber stress:

$$S = \frac{M c}{I} = \frac{3,401,487.9 \times 50.2775}{23,732.425} = 7,590 \text{ lb. per sq. in. max. fiber stress in sides.}$$

Center sills:

Area of two 15 in., 33 lb. channels	= 19.8 sq. in.
Area of cover plates, two top, 23 in. by 1/4 in.; one bottom, 23 in. by 5/16 in.	= 18.69 sq. in.
Total	= 38.49 sq. in.
Assumed maximum buffing stress	= 400,000 lb.
Unit buffing stress = 400,000 ÷ 38.49	= 10,400 lb. per sq. in.

Fig. 6—Stress Diagram for Steel Car of the Type Shown in Fig. 5

It is believed that in main line passenger car construction, where sills less than 12 in. deep at the center are provided, the deflection is such as to require support from the side girders. This is actually the case with many designs of framing and has never resulted in any ill effects on account of the potential value of the side girder, which has a large reserve, as shown in Fig. 6. This diagram has reference to a car weighing, complete, 150,000 lb., the weight of the trucks being 38,000 lb., the lading 9,000 lb. and the body 103,000 lb., and even with such an extremely heavy car the stress is less than 8,000 lb. in the side girder. To assist in this, it is possible to employ wide, continuous cover plates top and bottom of crossbearers, and lateral cantilevers connecting the side girders in a single length.

A casual study of the prevailing methods of design of steel framing for freight equipment shows that deep center sills are not countenanced except where conditions demand. The deep center sill is all very well for a flat car having no side support. Probably the most annoying car in the past has been the wooden flat car, which, when heavily loaded at the center, will rise at the ends, or when subjected to a severe shock will rise in the center. No designer would think of providing deep center sills for a hopper car with high sides; it would be a waste of metal and a useless expense.

It is the function of the center sills, with the draft gear and the buffers, to dissipate the greater portion of impact shocks, leaving under the most difficult circumstances only a small proportion to be withstood by the car body proper. Pulling strains are transferred to the side framing on most cars through the use of diagonal bracing and also by substantial cover plates over bolsters and crossbearers. Great care should be exercised to see that the underframe is designed to resist weaving and diagonal strains, which have a tendency to throw the frame out of square.

It has been recognized for many years that camber is a positive necessity in the formation of any design of girder having a considerable span. This is based on the principle that the compression members, which are normally the upper ones, shall not become tension members, as a reversal of the camber brought about by severe loading would cause

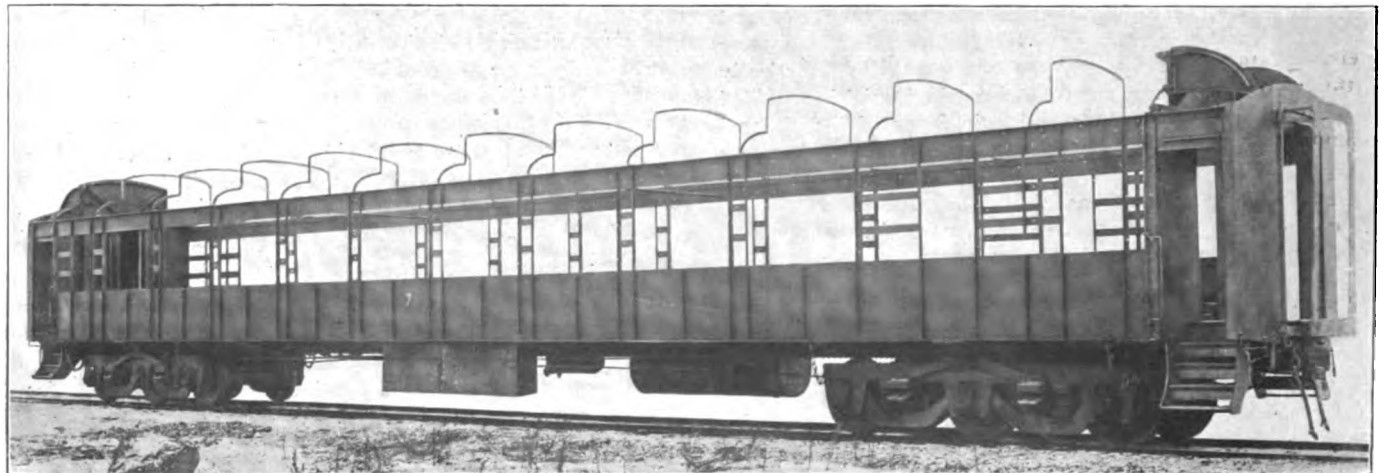

Steel Framing for a Car Which Has Wooden Sheathing

this condition and the consequent failure of the structure.

Extremes of design have not been discussed, as it was only the writer's aim to show the most suitable design of frame where steel is to be used. It is believed that the data sheet, Fig. 6, covers a design which is pre-eminently safe, even considering as it does the application of two supply boxes, two sets of batteries weighing one and one-half tons, a complete gas equipment and water raising system in conjunction with a large tank under the car and overhead storage tanks inside; also a superimposed load of 9,000 lb. all with an extreme fiber stress less than 8,000 lb. per sq. in. The frame is light, the total cross section of sides and center sills amounting to 77.23 sq. in. Reference may possibly be made to Fig. 2, which has an area of 70.97 sq. in., but when a car with a steel outside is considered the writer believes that advantage should be taken of the side plate and letterboard construction as a compression member; otherwise this means just so much dead weight.

If a 4 in. by 4 in. by $\frac{3}{8}$ in. side plate angle, a 2 in. by $\frac{3}{8}$ in. bar, a 13 in. by $\frac{3}{16}$ in. letterboard plate and a 2 in. by $\frac{3}{8}$ in. bottom stiffener were added to this design, it would increase the total cross sectional area by 13.60 sq. in., making a total of 84.57 sq. in., or result in an increase of $9\frac{1}{2}$ per cent, as compared with the design in Fig. 6.

EIGHT-WHEEL CABOOSE WITH STEEL UNDERFRAME

BY E. F. GIVIN

The Pittsburg, Shawmut & Northern has adopted the eight-wheel type caboose as standard to meet the regulations promulgated by the state of New York in 1913 and eight cabooses

been in service considerably over a year and have given excellent service in heavy trains hauled by four locomotives over grades of from 1 to 3 per cent. The cost of repairs during that time has been very small.

The car is 25 ft. long over the body end sills and 30 ft. long over the platform end sills. The width over the side sills is 9 ft., and at the eaves is 9 ft. $3\frac{1}{4}$ in., while the inside length is 24 ft. $6\frac{3}{8}$ in., and the width 8 ft. 6 in. When fully equipped and ready for service the weight is 36,000 lb. The floor plan was worked out so that cupboards and toilets did not interfere with the window arrangement and the uniform bracing of the body. The length of the car is only one foot greater than that required by the state law, but sleeping accommodations are provided for seven men, five in the body of the car and two in the cupola. The size of the cupola is based on the length of a berth 6 ft. 2 in. long and the seats were so designed that the seat and back cushions on one side could be utilized for a mattress in connection with a berth board which is kept in one of the closets when not in use. The five berths in the body have lockers under them which provide room for tools and supplies and such bed clothing as the crew wishes to carry. Special attention was given to the comfort of the trainmen, owing to their having to occupy the cars for sleeping purposes at outlying points.

The center sills are 15 in.-33 lb. channels placed $12\frac{7}{8}$ in. back to back with a $19\frac{3}{4}$ in. by $\frac{1}{4}$ in. top cover plate extending between the body end sills. The center sills are in three sections, the main or center section extending to a point $20\frac{1}{8}$ in. from the center of the body bolster. The end sections are spliced to the center section by two $\frac{1}{2}$ in. by 21 in. plates and secured in place by twenty-two $\frac{7}{8}$ in. rivets through the web and eight $\frac{7}{8}$ in. rivets through the top and bottom flanges, cover plates and outside splice plates. The end sections of the center sills are cut to accommodate the body and platform end sills. Top cover



Steel Underframe Caboose in Service on the Pittsburg, Shawmut & Northern; the Springs Used Are Double Elliptic Instead of the Helical Springs Shown

were built by the Russell Car & Snow Plow Company, Ridgway, Pa., in December of that year, from designs prepared by the mechanical department of the railroad. These cars have now

plates are used on the end section and extend from the platform end sill to the inner edge of the body end sill. The center sills are tied together at the bottom by three $\frac{3}{8}$ in. by 12 in.

plates equally spaced between the body bolsters. The end sections are connected at the bottom by a 3/4 in. by 6 in. plate with the ends turned up over the flanges of the sill and fastened by

inward. Riveted to the outside of the side sill is a 4 in. by 4 in. by 3/8 in. angle forming a bracket to support a 4 in. by 10 in. yellow pine side sill which mortises into the body end sill of the

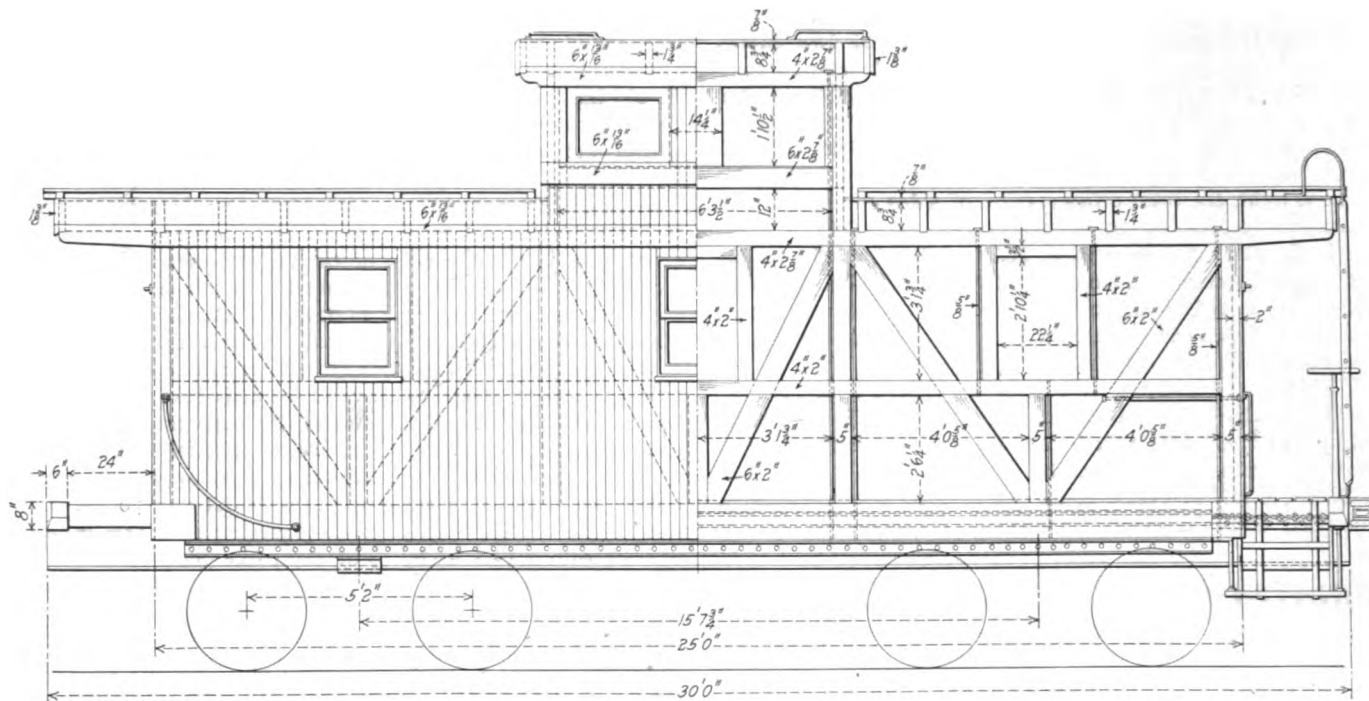

Body Framing of the Pittsburg, Shawmut & Northern Caboose

four 3/4 in. bolts with nuts and cotters. There is also a 4 in. by 1 in. carrying strap turned up over the flanges of the center

wooden frame. The end sills are of 5/16 in. plate with 3 in. by 3 in. by 1/4 in. angles riveted to both top and bottom on the out-

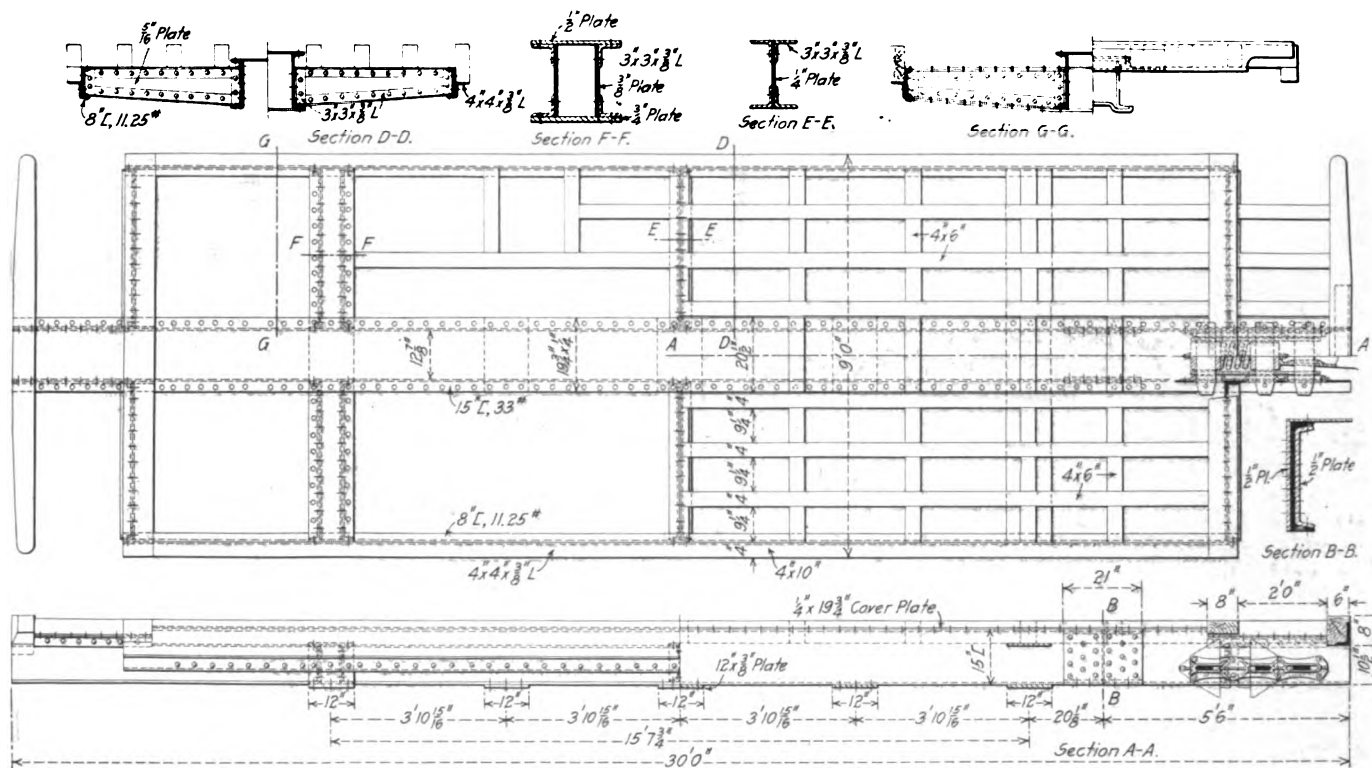

Arrangement of the Underframe Members

sills, the outside bolts passing through the flanges of the center sills.

There are two side sills consisting of 8 in., 11.25 lb. channels extending between the body end sills with the flanges turned

side of the plate. There is a cross-tie at the center of the car made of 3/4 in. plate with 3 in. by 3 in. by 3/8 in. top and bottom angles on both sides.

The body bolsters are built up of two 3/8 in. plates placed

vertically and extending between the side and the center sills with 3 in. by 3 in. by 3/8 in. angles, both top and bottom on the outside. They are connected to the center and side sills by 3 in. by 3 in. by 3/8 in. angles on the outside of the plate and have a 1/2 in.

low pine, tongued and grooved, running lengthwise of the car and covered with canvas roofing. The special equipment includes Buffalo Brake Beam Company's M. C. B. No. 2 brake beams, Simplex truck bolsters, New York air brake equipment,

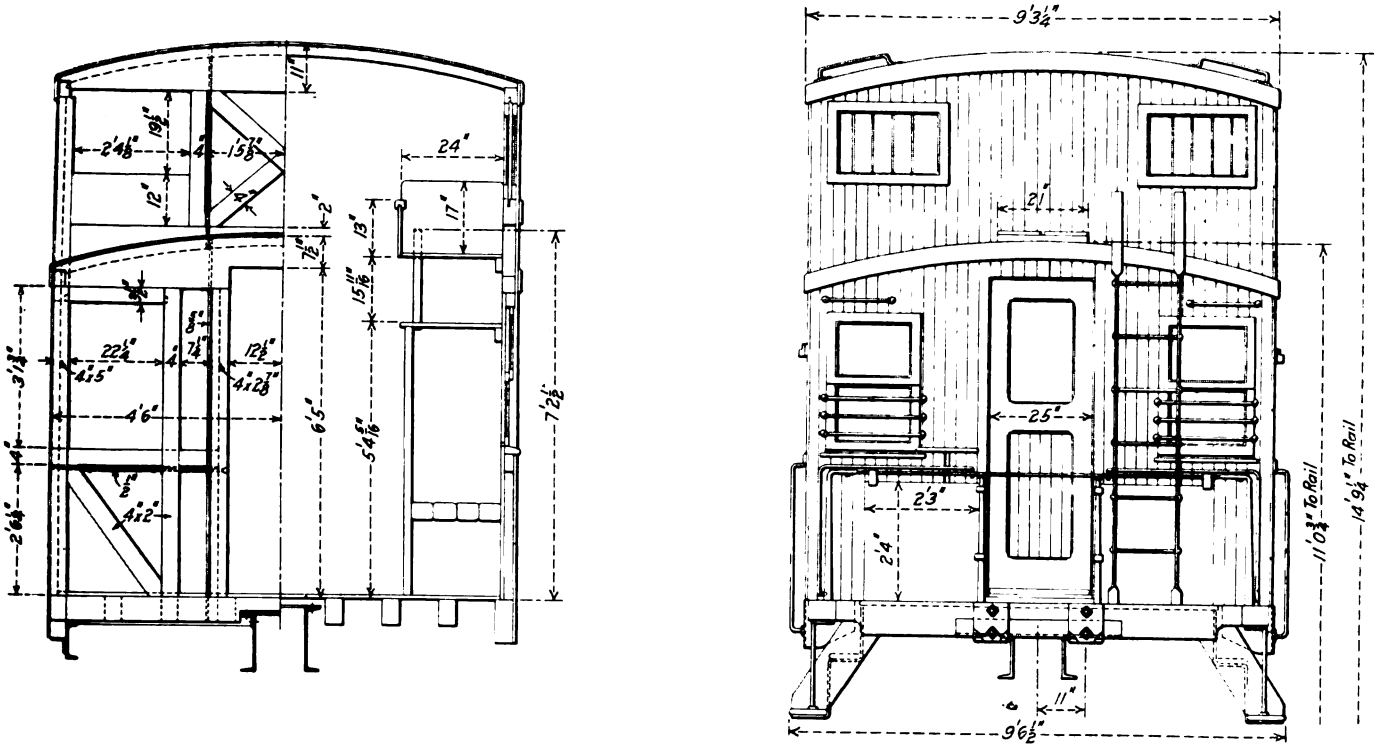

Cross Sections and End Elevation of the Shawmut Caboose

by 12 in. top cover plate, passing through the center sills and connected to the top flange of the side sill channels. There is also a 3/4 in. by 12 in. bottom cover plate passing under the center sills and connected to the center sills and the side sills.

The trucks are of the arch bar type spaced at 15 ft. 7 3/4 in. centers and having a wheel base of 5 ft. 2 in. They are equipped with double full elliptic springs and not helical springs as shown in the photograph. The cupola is placed on the center line of the car, with the cupola corner posts in one piece from side sills to cupola side plates. In the body framing the posts and braces are of yellow pine, the corner and the cupola posts being 4 in. by 5 in.,

Gould couplers, Acme uncoupling device and Farlow draft rigging.

IMPROPER LOADING OF BOX CARS*

BY W. H. SITTERLY

General Car Inspector, Pennsylvania Railroad, Buffalo, N. Y.

Several branches of the railroad service are directly interested in the matter of improperly loaded box cars; first, the agent of the railroad, who can assist if he will endeavor to have loaded at his warehouse and teaming tracks only such cars as are fit for

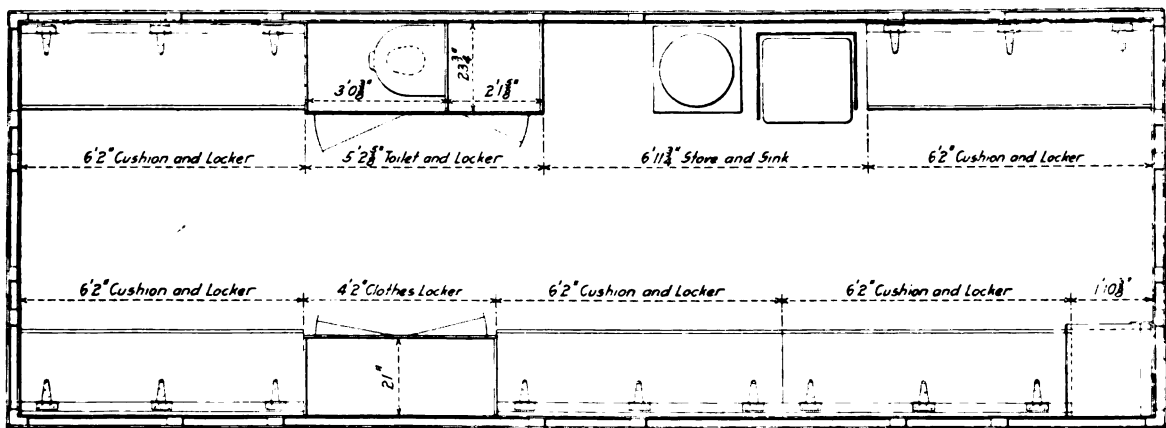

Floor Plan of Steel Underframe Caboose Used on the Pittsburg, Shawmut & Northern

while the end and door posts are 2 7/8 in. by 4 in. The belt rail is 2 in. by 4 in. yellow pine and the body end plates are 2 7/8 in. by 12 1/2 in. oak. The body side plates are 2 7/8 in. by 4 in. yellow pine, while the carlines are of oak, 1 3/4 in. by 2 1/2 in., cut to a radius of 16 ft. on the upper edge. The roof is 13/16 in. by 3 1/4 in. yel-

loading. A strict observance of the inspector's shop marks on the car by his subordinates will be the means of the defective

*From a paper presented before the Car Foremen's Association of Chicago and re-read before the Niagara Frontier Car Men's Association, Buffalo, N. Y., January 20, 1915.

car moving to the shop repair track instead of receiving a load and then moving to the shop for repairs before it is placed in a train, thereby reducing the revenue that the company should receive for transporting the commodity to its destination. Proper stowing of some commodities in the car by the agent's forces will prevent their coming in contact with the doors en route.

I believe that every car man can recite cases where cars have been loaded at the freight station and teaming siding to be delivered to a connecting line, the line making the switching movement receiving but \$3 for such movement and paying to the receiving line from \$4 to \$20 for a transfer or readjustment of the lading. Instead of the line which made the switching movement receiving a profit from each haul, it was assessed a large amount of money above the switching charge. This also applies to a load where the destination is on the line where the car was loaded. Instead of being placed in the first train and moving to destination, it makes a shop track movement; a large amount of money is spent on it due to defects, reducing the amount of net revenue.

There is another feature to be taken into consideration besides the money lost in the immediate case, and that is a dissatisfied shipper. He expects the commodity to reach his customer on a certain date and it does not, for the reason that the car makes a shop track movement with the load and is delayed in transit from 24 to 48 hours, and in some instances longer. This is particularly bad in a competitive district.

I have found in a great many instances where I have investigated cases of delays and claims for damage that cars bearing inspector's shop marks have been moved from the distributing point to the loading point and loaded. At the time of collecting the cars for distribution, some time of course was saved in *not* switching out the defective car. One department saved some time, but did the railroad in the end save or lose money? The answer is clear.

A group of thirty photographs taken in one of the large yards recently shows the condition of the lading in closed cars. They give a very good idea of the poor loading and the absence of doorway protection. In every instance, the initial road or the road loading the car was at fault in not seeing that the load was properly placed in the car and if necessary doorway protection added. The initial road was not assessed with the cost of rearrangement and the application of doorway protection, but the second or third road handling the commodity had the revenue reduced very materially.

A number of cases of bad loads originate at stations where there is no inspector located and the agent passes judgment on the load. Not being thoroughly conversant with the rules he has insisted on the misapplication of the rules, where if he had taken the matter up with his superior officer and requested the services of a car inspector or other representative thoroughly conversant with the rules, the load would have been properly loaded, the shipper satisfied and the load would reach its destination much sooner, passing by a repair yard instead of into it for adjustment or possibly transfer.

It is the duty of every railroad to educate the shippers located on its lines in the proper method of loading material, both in open and closed cars. This can be done very easily by furnishing the industrial plants with a copy of the Master Car Builders' loading rules and delegating a representative of the railroad who is thoroughly familiar with them to instruct the shipper. I have had considerable experience along this line and while I have met with some objections from shippers, the majority have shown a willingness to co-operate with the railroad company in the proper loading and securing of their commodity so as to insure its reaching its destination safely and without delay. Co-operation of the railroads along these lines at large terminals is absolutely necessary and what are the demands of one railroad as to loading, if in strict accordance with the Master Car Builders' loading rules, should be the demands of each railroad in that district. In this manner, improper loading will be reduced to a

minimum. It is, however, absolutely necessary that the representative who is delegated to impart the information to the shipper be thoroughly conversant with the loading rules, as I have found in some cases that inspectors or other railroad representatives have insisted on the shipper using a certain rule which did not apply to the particular load.

In a large district, it is surprising the number of foreign cars that are held in the shop and transportation yards awaiting disposition from the owner on account of their physical condition. I can safely say without fear of contradiction that a large percentage of these cars started away from the loading point carrying a load and it was necessary to shop the cars and transfer all or part of the lading in order to make repairs. In some cases the car never reached the destination intended with the load, the load going forward in another car.

During the past year I have had occasion to watch the physical condition of the box car, which I must say is deplorable. Box or house cars are placed on the shop tracks, and sheathing and siding renewed over posts and braces which are split and in a great many instances posts are decayed at the base or ends. The car receives a load, bulges at the sides and ends, and claims frequently result from loss or damage. I refer particularly to the time of the year when the demand is great for box cars for moving grain out of lake ports.

At one of the large terminals I made a check for a few days and the accompanying table shows cars shopped on account of apparently improper loading, causing bulged doors, shifted loads, etc. Instead of showing the names of the roads, I have used a numeral to represent them.

Road	Total cars	Total days delay	Per diem expense	Cost, material and labor	Total cost	Avg. cost, material and labor per day	Avg. cost, material and labor per day	Avg. cars per day	Avg. No. days delay per car
1...	13	36	\$10.15	\$18.02	\$28.17	\$1.39	\$2.17	0.4	3
2...	296	395	106.05	296.18	402.23	1.00	1.35	10.0	1.3
3...	39	45	15.75	34.68	50.43	.89	1.30	1.0	1.2
4...	67	110	38.50	44.12	82.62	.66	1.23	2.2	2
5...	104	205	61.95	211.54	273.49	2.03	2.63	3.5	2
6...	11	42	11.90	18.12	30.02	1.65	2.73	.3	4
7...	10	8	2.80	4.14	6.94	.41	.70	.3	1
8...	20	22	6.65	13.68	20.33	.68	1.01	.6	1.1
9...	18	18	4.20	18.06	22.26	1.00	1.23	.6	1
10...	4	4	1.40	3.42	4.82	.85	1.20	.1	1
Total.	582	885	\$259.35	\$661.96	\$921.31	\$1.14	\$1.62	19	1.6

When working under an agreement, as in the Niagara district, the delivering line passes a car on in order to expedite the movement of freight, which to my mind is not expediting it because it does not make any difference whether a car of this kind lies two days in "A" road's yard for transfer or adjustment, or whether it lies in "B" road's yard for two days.

It has been found that at points where a car inspector is not located, loads are often unevenly distributed in cars through the ignorance of the loader and also due to the agent not understanding the absolute necessity for a proper distribution of the lading, and a number of derailments have resulted from this cause.

A large number of railroads are placing in service new 80,000 and 100,000 lb. capacity box cars and frequently the first load they receive is fertilizer, hides, oil and tar in barrels, destroying the car for the loading of high class commodities. Many car department men have undoubtedly seen this class of car loaded in this way, and adjacent to the car an old empty 60,000 lb. capacity car perfectly fit for the load of hides.

RAILLESS TRAM CARS.—After being in use for only a few weeks, the system of railless cars, which was started in Shanghai by the Shanghai Tramway Company, has, it is announced, had to be suspended for the time being. The only road traversed by the vehicles was the Fekien road, and when everything was promising well it was found that the road foundations were in such a weak condition as to be unable to stand the weight of the cars. The only way for the service to be retarded is for the road to be concreted.—*The Engineer.*

TESTS OF EXHAUST VENTILATORS

Conducted to Determine Operative Efficiency;
Comparison Between Laboratory and Service Tests

BY GEORGE L. FOWLER
Consulting Mechanical Engineer, New York

During the past winter an investigation was conducted to determine the operative efficiency of the Standard exhaust ventilators used on the passenger equipment cars of the New York Central. Prior to this the only data available as to their operation was that obtained in laboratory experiments conducted by the makers, the Standard Heat & Ventilation Company of New York, to determine the ratio existing between the velocity of the wind blowing over the ventilator and the volume of air that would be exhausted by the action of the ventilator. This data will be referred to later.

The Standard exhaust ventilator is pressed from sheet steel and its general outside appearance is that of a quadrilateral pyramid with one side removed. Its base, which is open, is bolted to a side opening in the deck of the car. Its bottom is the side removed and the shape is such that when air is moving past it, either parallel to the center line of the car or at an angle thereto, an induced current is produced, flowing out at the open side. As this opening communicates directly with the interior of the car, through the base, this induced current is supplied by the air within the car and the exhaustion of this air follows, coupled with the ventilation of the car itself.

The purposes of the investigation were to ascertain the quantity of air removed from the car per hour, under the ordinary conditions of service; the rate of the exhaust removal of air at various speeds, so as to obtain the percentage of efficiency as compared with the results of laboratory investigation, which latter may be regarded as the theoretical or highest efficiency; the effect of wind direction; the effect of the location of the ventilator on the car, or the car in the train; the movement of the air currents within the car; the variation in barometric pressure within and without the car, and the amount of air delivered at the breathing zone.

The car selected for the purpose was a standard steel passenger coach of the New York Central lines. It was 69 ft. 4 in. long inside and had a seating capacity for 84 passengers and a cubic content of about 5,160 cu. ft. The car was fitted with twenty Standard exhaust ventilators, ten on each side, alternating with plain perforated metal deck opening screens of which there were eleven on each side. Both deck and exhaust openings could be closed by a Cheeny deck sash. The deck openings measured 28½ in. by 8¾ in. The exhaust openings were trapezoidal in form and had a free opening of 54½ sq. in., or 378 sq. ft., which was reduced by the dial of the anemometer placed in front of them to .359 sq. ft. No screen or netting was used with them.

INSTRUMENTS

For the purposes of the investigation the car was equipped with a vane anemometer, registering to 100,000 ft. of air flow, placed in front of each of four of the exhaust openings on each side. There was one at each end exhaust, with the other two spaced equally between, which made one for each third ventilator.

A cup anemometer of the regulation government type, was placed on the center of the roof of the car deck on the outside. It was arranged to make and break an electrical circuit for each one-tenth of a mile of the flow of the wind. This electrical circuit was arranged to operate a telegraph sounder by which a signal was given for each one-tenth of a mile of flow of air over the roof of the car.

A Boyer speed recorder was attached to one of the axles of the car, and the wire to the indicator was led up into the car. This made it possible to observe the speed at any instant and also retain a graphical record of the speed of the whole run.

A wind vane of standard government dimensions was placed on the center of the deck roof, in line with the cup anemometer, but at the other end of the car. The stem from this vane extended down into the car and had attached to it a pointer rotating over a dial, thus indicating at all times the angle at which the wind was blowing against the car, as a resultant of its own normal motion and that of the car.

A clock was arranged to make and break an electrical circuit at two-minute intervals. This was connected with a bell which sounded a signal for the taking of readings.

The apparatus used for the determination of the variation in barometric pressure, inside and outside the car, consisted of a wooden box, measuring 7 in. by 7 in. by 8¼ in. In each of five of the six sides of this box, eight holes were bored. These were each 5/16 in. in diameter and were widely scattered over the sides. In the sixth side a hole was bored large enough to admit the insertion of a rubber tube having a bore 3/8 in. in diameter. One end of the tube thus communicated freely with the interior of the box, while the other end was attached to one leg of a U-tube, which was half filled with colored water. The box was bolted to a board which replaced one of the deck opening screens. The small holes opened to the outside air and the rubber tube led down to the U-tube within the car, one leg of which was open to the air inside the car. It was thought that the air entering the box through the small holes, and under the influence of the pressure, would have its velocity greatly reduced by the relative sectional area of the box to that of the holes; that it would be so essentially calm as to produce no effect either for exhaust or pressure at the end of the tube, and that the barometric pressure within would be that of the external air, uninfluenced by the motion of the car. The areas were to each other as about 80 to 1, so that air entering the box at the highest recorded wind velocity, even though unchecked by passing through a rough hole 5/16 in. in diameter and 1 in. long would move through at a rate of less than one mile an hour.

MOVEMENT

The car, so equipped, was handled on regular passenger trains for one round trip between Albany and Buffalo; two round trips between Albany and Syracuse, and one round trip between Albany and Weehawken, a total distance of 1,466 miles. With one exception the trains were express. Between Albany and Buffalo six intermediate stops were made westbound, and sixteen eastbound. Between Albany and Syracuse there were fifteen westbound and twelve eastbound. Between Albany and Weehawken, there were thirty-four southbound and ten northbound.

OBSERVATIONS

Readings at two-minute intervals were made of the speed of the train, the velocity of the wind relative to the car and the direction of the wind relative to the car. At fifteen-minute intervals readings were taken of the anemometers in the exhaust openings, and at intervals between these readings observations were made of the rate at which air moved through the exhaust openings. The readings for these observations were taken at 15 and 30 seconds intervals, the time and speed

of the train being also noted. From the time at which the observations were made it was possible, by means of the two-minute readings, to determine the velocity of the wind relative to the car.

AMOUNT OF AIR REMOVED PER HOUR

The amount of air removed from the car per hour was determined by the regular readings of the anemometers placed in the exhaust openings. The individual readings were widely scattered, but, when grouped and gathered under averages of speeds increasing by increments of five miles an hour, they were found to increase with the speed, and show, as would be expected, that the amount of air removed varied with the speed. The amount of air removed from the car under observation, in the eight runs involved, averaged 296,659 cu. ft. for each of the eight ventilators to which anemometers were attached. If this total is divided by the number of hours that the car was under observation, which was 41, we have an average removal of 7,236 cu. ft. of air per ventilator per hour. This covers all speeds and conditions of operation from standing still to 76 miles an hour. The average speed of all the trains between terminals was 35.7 miles per hour, elapsed time.

The rate of the removal of the air through the exhaust ventilators was obtained by taking readings of an anemometer, placed at one of the openings of an exhaust ventilator, at such short intervals of time, and in connection with the actual speed of the train at the instant, that it was possible to determine the actual rate at which the air was removed at different speeds of train and wind. During the whole period of these investigations, there was little or no wind stirring. The result was that wind velocity relative to the car corresponded very closely to that of the car itself.

The readings referred to were taken at intervals of 15 or 30 seconds, and at speeds that ranged from zero to 75½ miles an hour for the speed of the train, and from zero to 72 miles an hour for the speed of the wind relative to the car. There were 201 of these observations, and they have been grouped together in five-mile intervals of speed and plotted in the accompanying diagram, under the average speeds. The anemometer readings, thus obtained, have been taken to indicate the rate of flow of air through the ventilator at the several observed speeds, and this has been considered to have been uniform throughout the whole area of the exhaust opening. This is warranted by the results of laboratory investigations, in which it was found that, when the direction of the wind currents was parallel or nearly parallel to the center line of the car, the rate of exhaust flow was uniform over the whole area of the ventilator opening. This diagram shows a general progressive increase in ventilator capacity on a straight line up to 60 miles an hour of train and wind speed. In this case, the train and wind speeds being so nearly the same, it is impossible to differentiate between them in the construction of the median line.

For the purposes of comparison the diagram of the ventilator capacities obtained in the laboratory is plotted with those obtained in service. In the case of the laboratory investigation the capacities given are those obtained with the air moving parallel to the center line of the car, and it is interesting to note that there was a steady increase of capacity directly as the speed up to 60 miles an hour, followed by an immediate falling off as that speed was exceeded.

Owing to the absence of wind during the tests the direction of the resultant wind relative to the car indicated only a slight deflection. The average for all of the runs was but 9.35 deg., and it was near this point that the vane stood for most of the time. For this reason it is fair to compare the ventilator capacities obtained in practice with those of the laboratory, as is done on the diagram. If a comparison is made of the relative capacity of the ventilator under the two conditions, it will be found that up to a speed of 60 miles an hour the efficiency

in service was about 70.5 per cent of the theoretical capacity of the ventilator, as measured by the laboratory experiments.

For the purpose of making a practical application of these results, let us take the figures already set forth as an example of what was done on the eight runs under consideration. In these we have an average performance per ventilator of removing 7,236 cu. ft. of air, and that at an average speed of 35.7 miles an hour, and under widely varying conditions from standing still to a speed of 76 miles an hour. According to the diagram each ventilator should remove about 6,700 cu. ft. of air per hour. The actual performances through a wide range of conditions check very closely, therefore, with those obtained from a detailed study of an individual ventilator. As the line of the diagram is straight from 0 to 60 miles an hour, the capacity of the ventilator varies directly with the speed, and may be obtained by multiplying the latter by 188.

Again, if we take the average speed of the train during elapsed time from the start to the last reading of the anemometers, and credit each anemometer for the removal of an amount of air corresponding to the elapsed time and the average speed

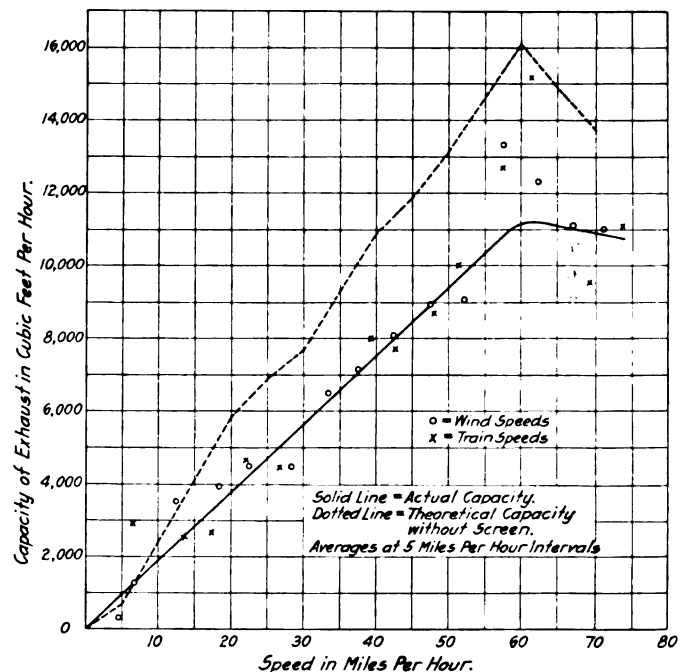

Capacity of Standard Exhaust Ventilator as Determined by Laboratory and Service Tests

of the train in accordance with the diagrams presented, it will be found that, according to that diagram, each ventilator should have removed 282,797 cu. ft. of air. Comparing the two, we find the average actually removed was 4.9 per cent more than that calculated with the diagram as a base. Hence the diagram may be assumed to represent the conservative capacity of the ventilator, as this small percentage of variation is well within that allowable.

EFFECT OF LOCATION

During the course of the investigations the car was placed in different positions, from being next to the engine to the seventh in the train. It will be readily understood that the data available from so small a number of runs is too meagre to make definite conclusions possible; but what there is indicates that the location of the car in the train does have an effect on the operation of the exhaust ventilators. In order to determine this it was necessary to consider both the amount of air exhausted and the speed of the train. In this I have taken the total amount of air exhausted and prorated it among the eight ventilators that were fitted with anemometers. This gives the average rate of operation for the car.

According to the diagram the amount of air exhausted varies directly with the speed, so that by dividing the average amount of air exhausted by the average speed of the train a quotient will be obtained that may be called the base unit of the operation of one ventilator for the particular run under consideration. If we take the averages of all readings and plot them in accordance with the location of the car in the train we find that there is a slow falling away in total capacity as the car is moved back from the engine; until for the seventh car, it is about 14 per cent less than for the first.

The effect of ventilator location on the car is also noticeable. By taking the ventilators, fitted with anemometers in pairs, as they were opposite each other, and averaging each pair for the several trips, it appears that, going back from the front, there is a steady fall in efficiency from the first to the third, with a rise for the fourth.

This indicates that the ventilators at the forward end of the car are most efficient, and that there is a falling off in efficiency at the middle of the car and a rise again towards the rear.

MOVEMENT OF AIR CURRENTS WITHIN THE CAR

Careful observations were made of the movement of the air currents within the car. This was done by means of smoke produced at the points at which it was desired to make observations. The doors and windows of the car fitted closely in their frames. At the cracks of the doors there was never sufficient air movement to operate an anemometer, though a coolness could always be detected. Also in the body of the car below the seven-foot line above the floor, no air currents of sufficient intensity to operate an anemometer could be detected at any time. The anemometer explorations were, therefore, all made in the deck space.

When the car was running at 60 miles an hour, an anemometer placed at the back end of the deck opening, which was 5 ft. 6 in. from the end of the car, showed air velocities of from 180 to 575 ft. per minute when the opening was at the front end. One-quarter of the way across the deck and opposite the opening they were still higher, and when the anemometer was placed close to the ceiling, they ran from 735 to 976 ft. per minute. Out at the middle of the deck, still close to the roof, they fell to from 250 to 440 ft. per minute. As the exhaust was approached on the opposite side of the car, three-quarters of the way across, the velocities increased again to from 600 to 680 ft. per minute. Dropping down into the car they ranged from 700 to 835 ft. per minute, even as low as the deck sill, but no movement of the anemometer could be obtained below the line of the parcel rack. This will give an idea of the velocities at which the air entered the car.

Studies of smoke movement showed that, when produced in the deck, it did not come down into the body of the car, but swept along towards the nearest exhaust ventilator and was carried out. When produced below the line of the deck sill it was quickly dissipated, but slowly came down into the car and then took an upward movement towards the ventilators. When produced in the body of the car in the breathing zone, it started at once for the deck, was nearly dissipated when it reached the sash of the ventilators and was then carried out with great rapidity.

On the run from Albany to Weehawken and return, observations were made as to tunnel conditions and effect. It is the practice of the road to close all of the deck openings and, at times, all of the exhaust ventilators, when passing through tunnels, of which there are three of some length. These are known as the West Point, Haverstraw and Weehawken tunnels. There is a fourth and shorter one at Rondout creek, but the locomotive is out of this before the rear of the train has entered.

In the runs under consideration all deck openings and all of the exhaust ventilators to which anemometers were applied, were left open. Immediately upon entering the tunnels, large

volumes of dense black smoke rolled in at the front deck openings. The smoke swept back along the roof of the deck and out at the exhausts. None of it came down into the body of the car and none of it was perceptible to the senses, even to those immediately beneath, when it was so dense overhead as to obscure the head lining. This was true not only of the experimental car, but also in the regular working coach occupied by passengers, whose ventilation was regulated to accord with that used in the experimental car itself.

The runs from Albany to Weehawken, on the West Shore, were made with the twofold object of obtaining data as to the action of the ventilators in tunnels and when running alongside a high bank with a free and clear space on the other side of the car. These conditions obtained on the West Shore, where, for long distances, the track is laid along the bank of the river with high, steep banks on the west and the open river on the east.

It was suggested that, under these conditions, it might be possible that eddy currents, created by the normal wind and the movement of the car close to the bank, might be of such a character as to cause the exhausts to act as intakes. Nothing of the kind could be detected. The ventilators invariably performed their true functions as exhausters of the air within the car, whether running in the open, through tunnels or close to a side bank.

BAROMETRIC PRESSURE INSIDE AND OUTSIDE THE CAR

Under all ordinary working conditions, there was no perceptible difference in the height of the water in the two legs of the U-tube. But, with all deck openings closed, and the 20 exhaust ventilators, with which the car was equipped, open, there was a rise of level on the car side of the U-tube of 1/16 in. when the car was running at a speed of 53 miles an hour, and the wind velocity over the roof was about 5¼ miles an hour, thus showing that, under these conditions, the ventilators were capable of producing a partial vacuum in the car.

AMOUNT OF AIR DELIVERED TO THE BREATHING ZONE

Attention has already been directed to the fact that the circulation of air through the car, under all conditions of service, was of too quiet and gentle a character to be measured or detected by the delicate anemometers used. That there was a circulation, constant and persistent, is shown by the observations of smoke movements. The means adopted to determine the efficacy and efficiency of this movement was that of taking samples of air from the breathing zone of working cars occupied by passengers. These samples were afterwards analyzed for their content of carbon dioxide.

The method is generally known as that of Pettenkofer and "consists in estimating the vitiation of the atmosphere by determining the amount of carbon dioxide that it contains, and from this computing the amount of air supplied for ventilation."

For the purposes of calculation it was assumed that each passenger would excrete .6 cu. ft. of carbon dioxide per hour, and that the incoming fresh air was diluted with 4 parts in 10,000 of carbon dioxide. The calculation is, then, simply that of estimating the amount of such air that would have to be supplied, for the time and number of passengers concerned, to produce an atmosphere containing the amount of vitiation indicated by the analyses of the samples taken.

The method of collecting the samples was as follows: Two ordinary cautory bulbs were used for pumping the air into the receiving bottles. The admission valves of the two bulbs were held close together and at arms length from the operator who squeezed them. Their delivery pipes led to the bottom of two clean 8-oz. white-glass bottles. The bulbs themselves had a capacity of about 4 oz. This method insured the delivery of the samples of air to the bottom of the bottle and the forcing of the previous contents out at the neck. In accordance with the practice and recommendations of the Bureau of Mines the

bulbs were squeezed at least fifty times in the collection of each sample. The use of two bulbs delivering to two separate bottles was merely to secure two samples as nearly identical as possible for check analyses in case of doubt or accident.

The samples were collected by walking slowly along the aisle of a working car. Immediately after the collection of the sample the necks of the bottles were closed by the insertion of soft rubber stoppers of the best quality obtainable, and, at the end of the run, these were in turn sealed by dipping in a melted mixture of beeswax and turpentine. Every possible effort was thus made to insure the samples being truly representative of the average condition of the air in the car at the time they were taken. They were all obtained from cars in regular service and the positions of the ventilator openings were recorded.

While the special car was in service, the working coach next to it in the train was used to obtain the air samples, and its ventilators were arranged in the same manner as those of the special car, the only difference between the two being the location of the two cars in the train and its effect on the operation of the ventilators. The effects of this have, necessarily, been neglected.

In a report to the Master Car Builders' Association, in 1908, a committee placed the amount of fresh air that should be supplied for the ventilation of a passenger car at 1,000 cu. ft. per passenger per hour. The results of these tests show that this amount was exceeded in every instance, and that this was accomplished without producing strong air currents or drafts in the breathing zone.

CONCLUSIONS

The conclusions to be drawn from this investigation are that:

One Standard exhaust ventilator will supply sufficient air to the breathing zone to meet the requirements of four passengers on the basis of 1,000 cu. ft. per passenger per hour. Its capacity varies directly as the speed of the train up to 60 miles an hour. The actual capacity in cubic feet per hour equals the speed of the train in miles per hour multiplied by 188. This actual capacity may be taken to be about 70 per cent of the theoretical rating.

The location of the car in the train has an effect on the efficiency of the exhaust ventilator. Speaking generally, the nearer the car to the engine the higher the efficiency. There is probably no mathematical ratio determinable for this.

The location of the ventilator on the car has an effect on its efficiency. The ventilators near the ends of the car have a higher capacity than those at the center, and those at the front have a greater capacity than those at the rear.

No perceptible drafts are created by the Standard exhaust ventilators below the tops of the windows. There is a gentle movement of the air down into the body of the car, and up to the deck in a complex system of currents, that cannot be differentiated.

Smoke or noxious vapors entering the car at the deck openings do not come down into the body of the car, but are drawn out through the exhaust ventilators.

High banks, cuts or tunnels have no effect on the action of the Standard ventilator.

It is not necessary to close the ventilators when passing through tunnels.

The heating of car near floor is successfully accomplished.

ETCHING ON GLASS.—A simple method of etching glass is to coat it with melted candle-grease, and draw the pattern to be etched in the wax with a sharp needle point. Then expose the glass to the action of vapor of hydrofluoric acid, generated by acting on fluorspar with hydrochloric acid, and gently warm. The gas must be generated in a lead vessel, as it attacks most substances. It is very poisonous, and, therefore, care must be taken not to inhale it.—*American Machinist*.

STEP-LADDER FOR SLEEPING CARS

The engraving shows a light step-ladder which has met with considerable success as an upper berth ladder for sleeping cars on the Canadian Northern. The main frame is made of channels, the folding legs are angles, the treads are covered with carpet and the whole ladder combines lightness with strength. The method of securing the top of the ladder to the berth insures against slipping and possible accident therefrom. The locking arrangement, details of which are shown in the drawing.

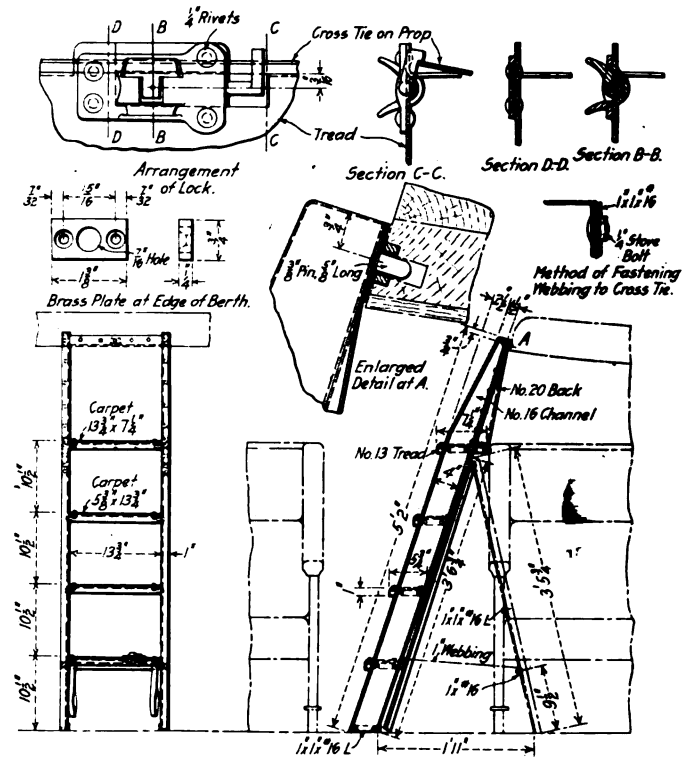

Step-Ladder Used in Sleeping Cars on the Canadian Northern

is on the back of the tread to which the 1-in. webbing is attached and serves to secure the prop against the ladder when not in use. The space between the top of the ladder and the top tread is completely enclosed at the sides and back. This ladder was developed in the office of A. L. Graburn, mechanical engineer of the Canadian Northern, Toronto, Ont.

ACCIDENTS DUE TO POOR LIGHTING.—That fully 25 per cent of the accidents to workmen are caused by insufficient lighting for men working at night, is the opinion of experts who have made a study of the subject. It is estimated that \$250,000,000 is the average annual cost of injuries to workmen in the United States alone, and that over 50 per cent of these accidents are preventable.—*Popular Mechanics*.

PROTECTING METALS AGAINST HEAT.—A recently discovered process, termed by its inventor "calorization," said to protect combustible metals from atmospheric action at high temperatures and make them available for a much wider range of usefulness than is now the case, was recently described in the *General Electric Review*. The metals are heated in revolving drums containing, among other things, finely divided aluminum, by which a surface alloy containing aluminum is produced. Pieces which because of their shape and size are not adapted for tumbling, may be calorized by packing them in, or painting them with a suitable mixture and heating them. After iron is calorized, the effect of heating is slight. Instead of burning and the scale falling off, as in the case of untreated iron, practically no effect can be detected.—*American Machinist*.

SHOP PRACTICE

BORING AND FACING BACK END MAIN ROD BRASSES AND DRIVING BOXES

BY M. FLANAGAN
Master Mechanic, Chesapeake & Ohio, Richmond, Va.

A special chuck for use on a 42 in. Bullard maximill has recently been fitted up at the Seventeenth street shops of the Chesapeake & Ohio, Richmond, Va., for boring and facing back

As shown in the drawing the base of the chuck is centered on the boring mill table by means of a cylindrical projection fitting into the central recess in the table and is secured by four bolts. The main jaws of the chuck are operated by a right and left hand screw in the base and each main jaw is provided with a

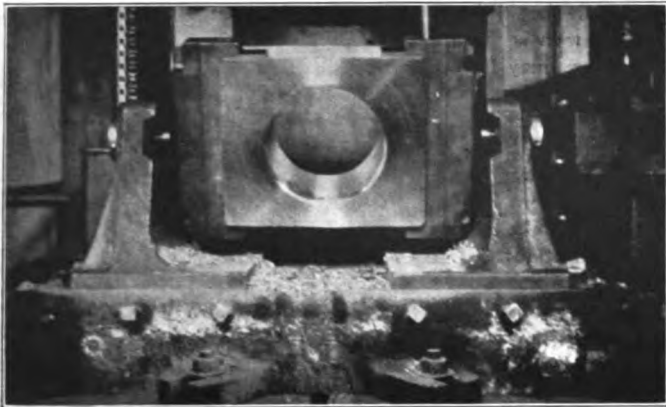

Rod Brass Being Reversed After Boring and Facing One Side

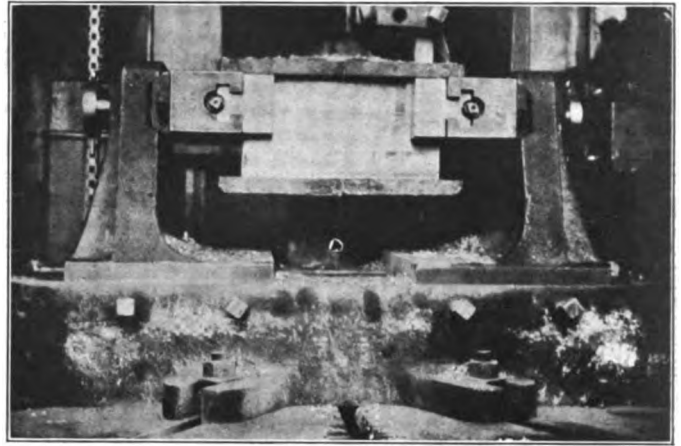

Back End Main Rod Brass In Position for Boring and Facing

end main rod brasses and driving boxes. The device was designed by Frank B. Moss, general foreman, and since it has

chuck, the horizontal jaws of which operate at right angles to the main jaws. These secondary chucks may be released and revolved through 180 deg., and again accurately located in a horizontal position by the pressure of the work.

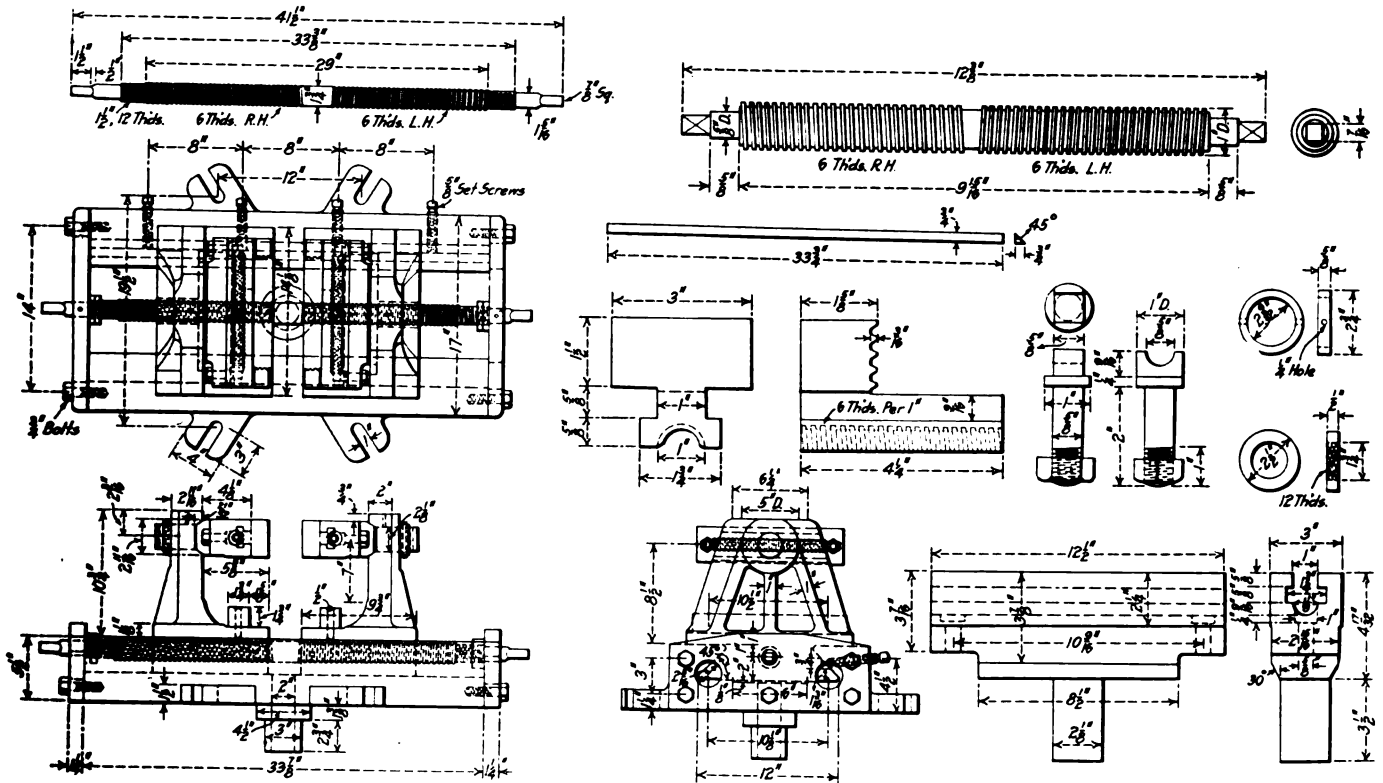

Details of Self-Centering Chuck for Back End Main Rod Brasses and Driving Boxes

been in use, laying out brasses and boxes for boring has been discontinued altogether as the chuck accurately centers and clamps them in line with the inside faces of the flanges.

After having finished the sides and inside faces of the flanges of a pair of back end main rod brasses they are placed in the chuck as shown in one of the illustrations, the universal action of the

chuck jaws accurately centering the brass when they are closed. The brass is then bored and one side faced and filleted. The main jaws of the chuck are then released and the brass, still clamped in the secondary jaws, is inverted. After closing the main jaws the brass is faced and removed.

When finishing these brasses by the old method of laying out, setting up and machining in an engine lathe, about two hours was required on each set, at a cost of 77 cents. By the use of this chuck the total time consumed on each set in the boring mill is about 10 min., and the cost of doing the work has been reduced to 6½ cents per set. In the accompanying table is given

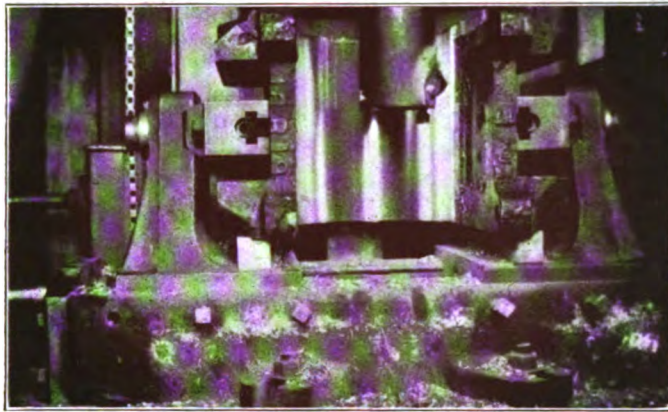

Driving Box Chucked for Boring and Facing

a record of the time expended in the various operations, from the time the brass leaves the floor until it is finished and again placed upon the floor. The time given is in minutes:

	Time chucking.	Time rough boring.	Time finish boring.	Time facing first side.	Time filleting.	Time turning over in chuck to face second side.	Time facing off second side.	Time chuck to floor.	Time floor to floor.
First brass..	2	2½	1½	1	½	1	1½	1	11
Second brass	2	2½	1½	1	½	1	1	1	10
Third brass.	2	2½	1½	1	½	1½	1½	1½	12
Fourth brass	1½	1½	1	1	½	1	1	1	8½
Fifth brass..	1½	1½	1½	1	½	1½	1	1	9½
Sixth brass.	1½	1½	1	1	½	1	1	1½	9
Average total time per brass, floor to floor, 10 min.									

When used for boring driving boxes the secondary jaws and screws are removed from the revolving faces of the main jaws and the latter clamped against the shoe and wedge faces of the box. The box is thus centered between the shoe and wedge faces and may be adjusted along the vertical center line to suit the requirements of the brass. The time used in laying out is thus eliminated and the total cost of boring and facing the boxes is reduced about 50 per cent.

VARIATIONS IN LOCOMOTIVE PERFORMANCE.—An article recently published by one of our contemporaries calls attention to the troubles attendant on the variations in locomotive running in that engines of the same class, hauling similar loads, over the same stretch of line, under identical running conditions, will sometimes show a disparity in running that is almost inexplicable. Again, a certain engine may run badly on one occasion, and yet do brilliantly on another, without any apparent reason for the difference. A certain driver, also, with a heavy express, to which his engine has been attached at an intermediate station, will make every effort to regain time, for the loss of which he is in no way responsible, whereas another driver, with the same type of engine and a lighter train, under similarly late conditions of running, will be content to adhere strictly to his schedule throughout. Such variations in locomotive running are the hardest of all to explain, as it is difficult to believe that there can be any difference in the constructional work sufficiently great to account for them.—*The Engineer.*

PIECE WORK AND BONUS SYSTEMS IN THE BOILER SHOP

BY N. H. AHSIULH

The fundamental purpose of both piece work and bonus systems is to increase the ratio of output to time consumed. It has been proved that this result can be successfully accomplished in locomotive boiler repair shops by either system and still turn out a high grade of work. The personal efficiency of the individual workman which is necessary to accomplish these results is frequently not developed, however, due to the lack of proper facilities, or to their improper arrangement, and to the lack of interest among foremen and their immediate superiors.

The foreman must take an active interest in the earnings of the men and should know approximately how each man or each gang of men is working. If they are falling below the earnings which they may be expected to make he should learn the reason and take steps to remove the causes of the reduced output. Where the men feel assured that the foreman is thus interested and that they may always expect fair treatment they will have a greater interest in their work and will accomplish much better results than would otherwise be possible.

In any efficiency system the efforts of the workmen are measured in units of output, and where he is paid on this basis the workman's interest is naturally to increase his output as much as possible, at times even at the expense of proper workmanship. The judgment of the individual is used to a greater extent in boiler repairs than in any other line of locomotive work, and the foreman must therefore be continually on the alert to see that good judgment is exercised and that the increased output does not result in any slighting of the work.

Under an efficiency system there are always some jobs that do not pay well no matter how great the efforts to increase the

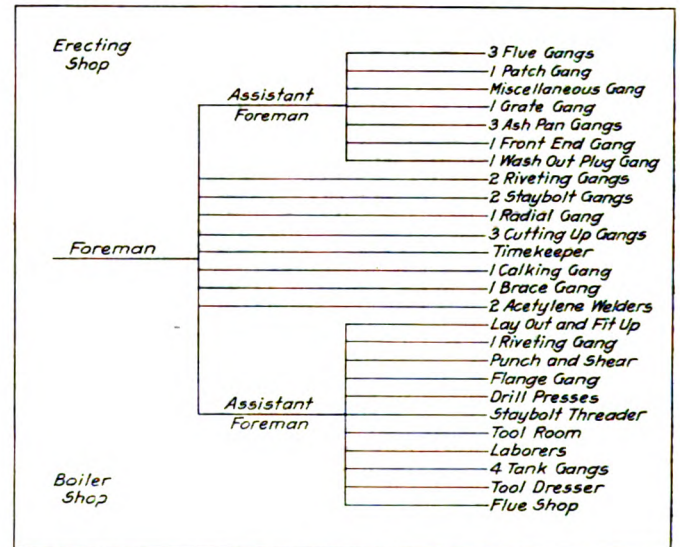

Fig. 1—Organization of a Boiler Shop Under the Bonus System

output. It is difficult to get men to stay on these jobs and to equalize matters the writer has had occasion to divide them among men who are on good paying work, but such conditions are usually a source of friction.

Fig. 1 represents the organization of a locomotive boiler shop which the writer has handled under a bonus system for several years. This organization is composed of a large number of small specialized units. The small units are required by the bonus system because bonus payments are based on individual effort and no provision is made for pooling workmen into a number of larger units as is done in piece work shops.

A portion of the force is divided into regularly assigned boiler

shop and erecting shop boiler gangs whose work is confined to their respective shops, the balance of the force being placed in either shop by the foreman as required. The staybolt gangs apply staybolts in both shops. The cutting up gangs remove fireboxes in the boiler shop and tube sheets, door sheets, etc., in the erecting shop. This division of the force into a large number of small units increases the difficulty of supervision as compared with a force of larger gangs, each in charge of a gang leader.

In the following table are given the operations into which the erecting shop boiler work is divided, together with the names of the gangs handling the different operations. With the exception of the riveting and flanging gangs each gang is made up of two men who perform but one or two operations on each boiler, the gangs following each other in the order shown:

1—Remove grates.....	Grate gang
2—Remove ashpan.....	Ashpan gang
3—Remove front end.....	Front end gang
4—Remove back tube sheet.....	Cutting up gang
5—Remove front tube sheet.....	Cutting up gang
6—Remove staybolts.....	Cutting up gang
7—Remove radials.....	Radial gang
8—Flange tube sheets.....	Flange gang
9—Fit and drive back tube sheet.....	Riveting gang
10—Fit and drive front tube sheet.....	Riveting gang
11—Apply braces.....	Brace gang
12—Apply radials.....	Radial gang
13—Apply staybolts.....	Staybolt gang
14—Apply washout plugs.....	Washout plug gang
15—Apply tubes.....	Flue gang
16—Calk hydrostatic test.....	Calking gang
17—Apply ashpan.....	Ashpan gang
18—Apply grates.....	Grate gang
19—Apply front end.....	Front end gang

During the year 1914, with an average of 68 men working 55 hours per week the output of the larger jobs involved was as follows:

Staybolts renewed.....	28,948
Fireboxes applied.....	17
Back tube sheets applied.....	26
Door sheets applied.....	4
Radial stays renewed.....	8,946
Crown bar bolts renewed.....	2,043
Half side sheets applied.....	4
Three-quarter door sheets applied.....	5
Tubes removed and replaced.....	30,608
Front tube sheets applied.....	19
Boiler patches applied.....	155
Firebox patches welded.....	26
Firebox patches lapped.....	24

This work was done in a shop having few facilities, the boiler shop machinery consisting of one set of 10-ft. rolls, two drill

radials are driven with air hammers. Careful attention is given to the fitting of work before riveting. Tube sheets and door sheets are fitted into place with acetylene gas burners, and when riveted it is never necessary to calk the seams; on firebox renewals the seams are never calked on either water or fire side. No rivets are allowed to be driven until the foreman has inspected the various seams and determined that the fit is absolutely metal to metal. The extra time thus required is more than justified by the time gained in riveting, and when the hydrostatic test is applied very few leaks are found. Considering the absence of facilities and the comparatively high earnings of most of the men the cost of work is low in this shop. Staybolts in new fireboxes are applied for about eight cents each complete and mud ring rivets for six cents each. Back tube sheets are fitted and riveted complete in the erecting shop for \$20 each.

The oldest of the so-called efficiency systems is the straight piece work system, which is now in use in several railroad shops. The organization of a piece work boiler shop is shown in Fig. 2. When a firebox job arrived in this shop the cutting-up gang dismantled and removed the old firebox and, if necessary, the front tube sheet. The new sheets went first to the laying-out and punch-gangs and were next turned over to the flange gang. The latter flanged and fitted up the new fireboxes, and where necessary the shell sheets. The work was then delivered to the firebox gang, who riveted and calked the firebox, riveted and calked the shell sheets, put the firebox in the shell, applied the mudring, staybolts, radial stays and front tube sheet, completing the boiler work ready for the tubes. The boiler was then generally taken to the erecting shop where the tubes were applied by the tube gang.

The erecting shop boiler work was handled by gangs of about five men each. These gangs each did all the work required on a single boiler, with the exception of the tubes, ashpans and the front ends, which were handled by specialized gangs. The duties of the cost inspectors shown in the organization chart were to write all piece work slips for the jobs as they were completed.

The pooled units in this shop being of a comparatively large size and the number a minimum, proper supervision was not difficult. The foreman could follow the output and earnings of each gang, and therefore was enabled to keep a better grasp on the situation in this shop than in the one referred to in Fig. 1. This organization was a complete success, and all the men made good money and turned out excellent work. Its special feature was the assigning of a gang of from five to seven men to one boiler on which it handled all the work, including the riveting, staybolt work, tube sheets, etc., the gang doing the work being responsible for the calking required on the hydrostatic tests. As a result there was a friendly rivalry among the different gangs which stimulated the men to do both the maximum amount and the best quality of work at all times. This incentive to do good work was a very important factor contributing to the success of the organization viewed from an efficiency standpoint. There was always a race to see which gang would get its boiler or firebox completed in the quickest time and to see which could turn out the tightest work, requiring the least calking in the hydrostatic test.

These gangs were made up of two boilermakers, one or two handy men, one or two helpers and a rivet boy. As the opportunity presented itself the helpers and handy men were promoted and given corresponding increases in pay. This is of great assistance in keeping the organization of a boiler shop intact. With no prospect of something better in the future, men are constantly quitting, and high efficiency cannot be obtained where it is necessary to be continually hiring and breaking in new men.

Of the two systems the straight piece work system is the better where a steady class of labor is available. But in many localities, where the right kind of labor is hard to secure and much harder to keep, the bonus system is the better because it guarantees an hourly rate regardless of the workman's efficiency.

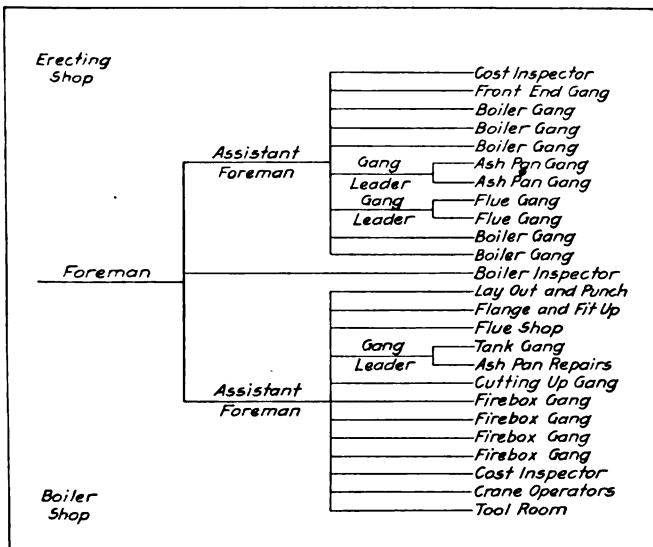

Fig. 2—Organization of a Piece Work Boiler Shop

presses, one punch and shear having a 28-in. throat, one staybolt threader, one hand clamp, one flanging forge and a set of air clamps. The boiler shop contains a few home-made jib cranes for handling fireboxes and there are no cranes in the erecting shop, an engine hoist being provided to wheel the engines.

All riveting is done with air hammers, and all staybolts and

The bonus system is much more complicated than the piece work system and is less apt to be thoroughly understood by the men in the shop. If the piece work price for calking 100 rivet heads is \$1, and a man calks them in 2½ hours, he immediately knows that he has made \$1 in 2½ hours; but in a bonus shop it requires considerable calculation to arrive at the earnings for any particular job.

It is a poor efficiency system which permits a boiler shop to turn out a boiler after a general overhauling, supposed to run from 18 to 20 months, in such a condition that within 3 or 4 months the roundhouse boilermakers are beginning to calk tube sheet flanges, renew leaking rivets in side sheet patches, renew staybolts in the fire line which were broken before the engine was shopped, and other work which should have been taken care of while the engine was in the shop. The intelligent determination of the repairs which are necessary and the careful supervision of the work while under way are most important considerations in the handling of a piece work or bonus shop. The foreman and his assistants and the boiler inspector must have a knowledge of the repairs required on each boiler in ample time to plan for the work before the boiler reaches the shop.

JIG FOR GRINDING GUIDE BARS

BY R. E. BROWN

Machine Shop Foreman, Atlantic Coast Line, Waycross, Ga.

A very simple device for lining up guide bars on a grinding machine is shown below. It consists of a base clamped to the table of the machine with two bolts and a guide rest pivoted to the base by a long taper pin. Two of these jigs are used, one under each end of the guide bar. The guide bar is first clamped to the guide rests, the set screws on the ends being loosened to clear the table at least ¼ in. The guide is then squared up by adjusting one of the set screws, the other being then turned down until it touches the table. The guide rests are then rigidly

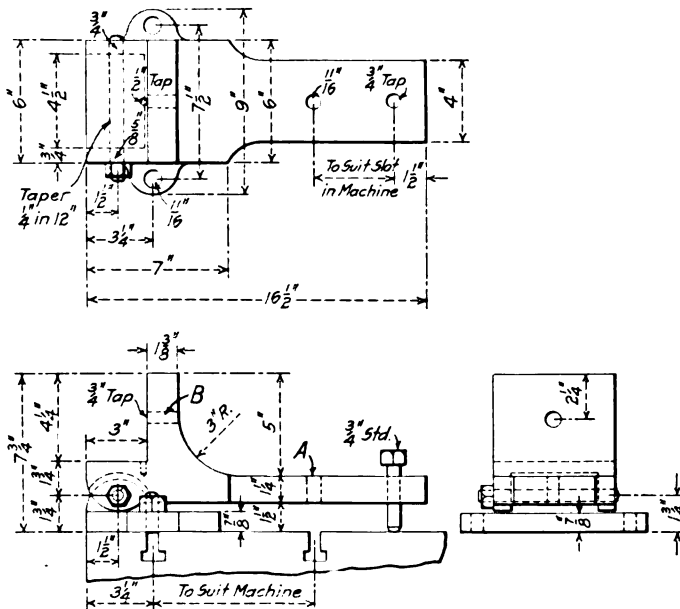

Jig for Setting Up Guides on Grinding Machine

secured by means of bolts at A and the guide lined up longitudinally by set screws in the tapped holes D.

This device eliminates the cut-and-try method of setting guides which is necessary when they are clamped directly to the table. By its use an experienced operator is enabled to change guides in about two minutes; and this is possible whether or not the guides are sprung, as the jigs automatically adjust themselves

to this condition. These jigs have been used at this point for about two years with excellent results, the output having been increased 50 per cent.

REPAIRING WORN AIR PUMP REVERSING RODS

BY J. A. JESSON

The device shown in the drawing is used for upsetting worn 9½ in. air pump reversing rods and for straightening those which are bent. It consists of two steel blocks, grooves in which enclose the reversing rod when the blocks are placed together. The blocks are held in alinement by means of the dowel pins shown in the illustration. When a worn rod is to be repaired it is first heated at the button end and placed in the blocks which are then clamped tightly together. The set A is inserted over the button head in the 1 in. recess at the end of the blocks and with a couple of blows of the hammer the button is driven against the shoulder E at the inner end of the recess. The same operation drives the collar between the rod sections B and C against the shoulder F in the blocks. The distance between shoulders E and F is such

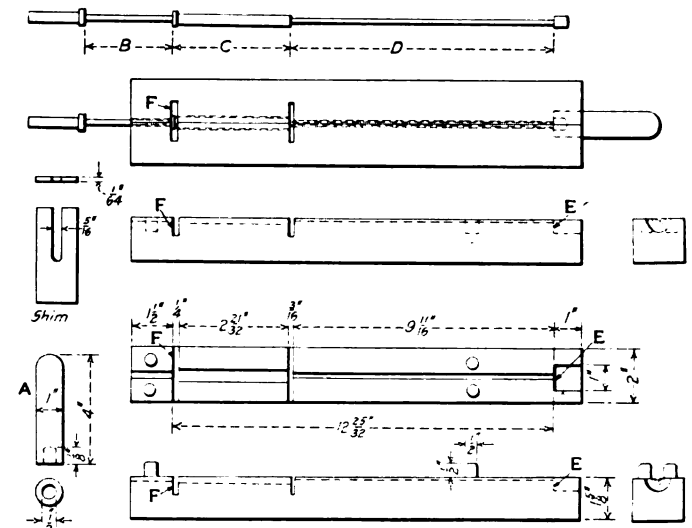

Dies for Upsetting Worn Air Pump Reversing Rods

that the rod is by this means restored to its original length. Should the rod at section C be too short it can readily be drawn out by swedging close to its end, and any bend in the rod may be straightened to conform to the groove.

Occasionally when repairing a rod so small in diameter that it will spring in the groove instead of closing up properly, the shim shown in the drawing is inserted in the slot between the collar on the rod and shoulder F. This holds the button end away from the shoulder at the end of the block far enough to compensate for the tendency to spring. The set fits closely in the recess in the block, and holds the button head in alinement during the upsetting operation.

COPPER AND WARFARE.—The magnitude of the estimated consumption of copper in the warfare in Europe is astounding. An English estimate of the copper consumption by the German and Austro-Hungarian armies is at the rate of 112,000 long tons per annum; a German estimate places the consumption at the rate of 100,000 metric tons per annum. The estimates are in close agreement and, therefore, probably accurate. If the Teutonic allies are consuming 100,000 metric tons per annum, their opponents must be using a quantity that is at least as large, which would indicate a total of 200,000 tons, or 20 per cent of the world's maximum production. At present the rate of production is materially less.—*American Machinist.*

FACTORS IN HARDENING TOOL STEEL*

Structural Changes Due to Heating; Quenching Mediums; Effect of Mass; Furnace Conditions

BY JOHN A. MATTHEWS and HOWARD J. STAGG, Jr.†

In this paper we shall confine our attention to carbon steels, together with some consideration of so-called special steels containing various alloys, usually below 3 per cent. We shall consider the subject, also, from the basis of sound well-worked materials, confining our attention to the hardening operation.

Carbon forms at least one definite compound with iron, Fe_3C , known as cementite. This is the hardest constituent in steel. Cementite exists in annealed steel associated with a perfectly definite quantity of iron, or ferrite, as it is metallographically known. This definite relation between ferrite and cementite yields the constituent pearlite, in which the cementite and ferrite may exist in a laminated or a granular condition. This aggregate contains a definite percentage of carbon, 0.89 per cent, and steel containing 0.89 per cent carbon in its normal condition, is found to consist of nothing but pearlite when examined microscopically. In steel containing less than 0.89 carbon the cementite associates with sufficient ferrite to form pearlite, and leaves the excess ferrite free in distinct microscopic grains or crystals. On the other hand, if the steel contains above 0.89 carbon, there is more cementite present than can become associated with ferrite, and the excess being unable to find a partner, so to speak, exists in separate particles, either granular or in a more or less perfect net work surrounding the pearlite. The

mentite. Practically considered, nothing is gained by doing so.

Steels quenched quickly from above the decalescence temperature retain the carbon more or less perfectly in the condition of solid solution that existed above the decalescence point. The structural name for the quenched product is martensite. Hypo-eutectoid steels, hardened, may show either all martensite or martensite and ferrite. Hyper-eutectoid steel should show martensite and cementite. Just as in the change of ice to water or of water to ice, there is an evolution or absorption of heat, so is there an absorption or evolution of heat in steel on passing through its critical range.

The permanent changes in dimensions which steel undergoes in hardening are of the utmost interest to the hardener, and associated with these changes is the problem of hardening cracks.

Le Chatelier has studied the phenomena of expansion or dilatation by accurate scientific methods, and has divided the changes into three zones of temperature: Changes at temperatures below that at which allotropic transformation begins; changes at temperatures above those at which allotropic transformation occurs; and changes occurring within the critical range itself. During the first of these periods from 0 deg. to 700 deg. C., iron and steel expand nearly equally, the amount of carbon exerting

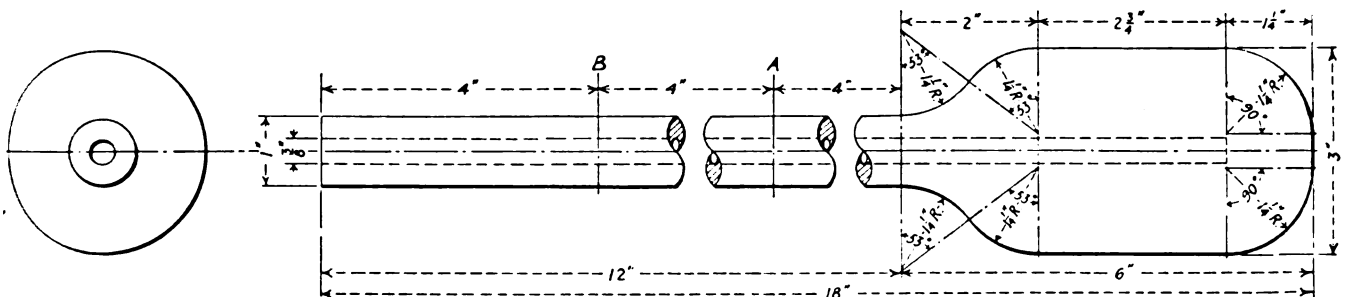

Fig. 1—Test Piece Used in Quenching Tests

definite percentage of carbon which yields a full pearlite structure in the annealed or natural condition is known as the eutectoid composition. Steels of lesser carbon are called hypo-eutectoid, and steels of higher carbon are called hyper-eutectoid steels.

When carbon steel is heated above a certain temperature, a change takes place in the constitution of the steel. This temperature is known as the carbon change point, critical temperature, or, preferably as the decalescence point. When this temperature is reached the pearlite becomes austenite, a solid solution of iron carbide in iron. This change occurs at a nearly constant temperature, but in case of hypo-eutectoid steels, the austenite first formed above the decalescence point acts as a solvent for the excess ferrite. In other words, at a somewhat higher temperature than the decalescence point, we obtain a homogeneous solid solution of all the cementite in all the ferrite. This is the best condition for hardening a low-carbon tool steel and accounts for the practice of heating low-carbon steels hotter than hyper-eutectoid steels for hardening. The excess cementite of hyper-eutectoid steels is not readily soluble in the austenite first formed from the pearlite and it requires a high temperature to complete the solution of the excess ce-

little influence. For any iron or steel, however, the amount or rate of dilatation increases with the temperature. Below 100 deg. C. the dilatation is about 0.000011 in., while between 600 deg. and 700 deg. C. it increases to 0.0000165 in. per deg. C. Above the critical range, however, the coefficient of dilatation varies directly with the carbon, and is nearly twice as great for a 1.20 carbon steel as for a 0.05 carbon iron. The changes taking place at the decalescence and recalescence points, Le Chatelier has not been able to study so satisfactorily. He has found, however, that the dilatation which increases directly with the temperature up to the decalescence point, suddenly stops and that instead of an expansion, a marked contraction takes place. On cooling steel from high temperatures, these changes in dimensions are reversed, although they are not quantitatively equal, nor do they occur at the same temperatures. The expansion of steel in heating to 750 deg. C. is about $\frac{1}{8}$ in. per ft., and when we recall that, in quenching, a corresponding contraction attempts to take place suddenly, it is little wonder that strains are set up that may exceed the ultimate strength of the steel.

After passing through the critical range, the expansion takes place at its maximum rate. When steel is heated above that temperature necessary to harden, it assumes the shape corresponding to the maximum temperature and on cooling the whole piece tends to return to, or near, its original size. In so doing the outer, or first cooled, portion is hardened first and forms a

*From a paper read before the annual meeting of the American Society of Mechanical Engineers held in New York, December 1-4, 1914.
†Hilcomb Steel Co.

hard, brittle, unyielding shell, and the strains set up by the slower cooling interior may either fracture the shell, producing external cracks, especially if the shell be uneven in thickness, or burst the piece at the center if the shell is of even thickness and strength. This latter occurrence is accompanied by a peculiar appearance of the fracture, and is frequently and wrongly called pipe.

Time of Heating.—Too much stress cannot be laid on the fact that there is a correct length of time for heating, and that this time of heating is as important as the temperature to which heated. There are at least two dangers which must be avoided. First, if the heating be too fast, a uniform temperature does not exist throughout the mass being heated. For example, a die block heated too quickly may exhibit the following conditions: The outer portions may be above the decalescence point, and expanding at the maximum rate; the intermediate portions

Second, grain size depends, among other variables, upon temperature above decalescence, and the time such a temperature is maintained. If heating be of such a character that the piece is held above the decalescence point for an abnormally long time, the crystals may have grown to such an extent that on quench-

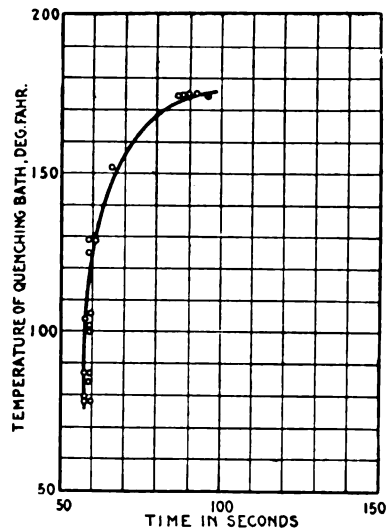

Fig. 2—Quenching Power of Pure Water

may be in the transformation range and contracting; while the inner portion, which is below decalescence, is slowly expanding. What wonder that steel fractures under such conditions?

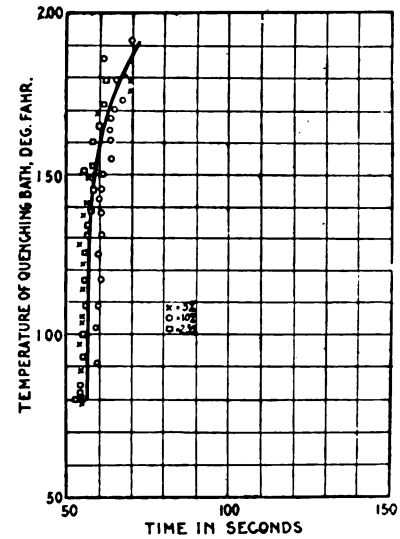

Fig. 3—Quenching Power of Brine Solutions

ing, abnormal grain size is retained and the result is a weak, if not cracked, piece.

Quick heating in a furnace which is considerably hotter than the correct hardening temperature is extremely bad practice. The difficulty is that the thin parts, corners and edges are liable to attain an overheated temperature before the larger portions of the piece attain the correct hardening temperature, and this overheating of the thin parts produces large grain size, abnormal expansion and tends to produce cracks.

Speed of Quenching.—If a sample of steel be cooled slowly from above the decalescence point, the solid solution which has been formed breaks up and precipitates its cementite and ferrite, and we have then an annealed steel. If the cooling on the contrary be rapid, the solid solution is not given the time necessary

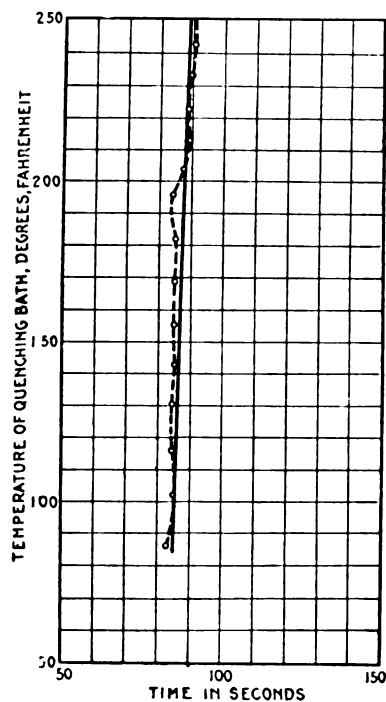

Fig. 4—Quenching Power of No. 2 Lard Oil

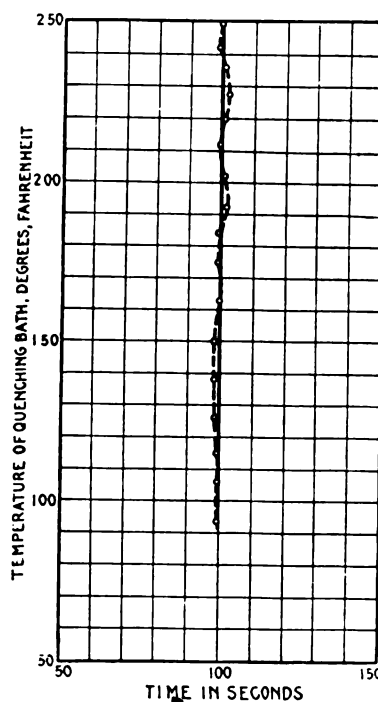

Fig. 5—Quenching Power of Prime Lard Oil in Use Two Years

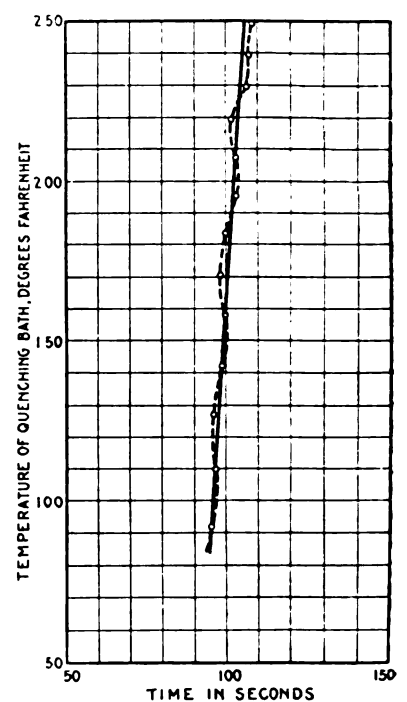

Fig. 6—Quenching Power of Raw Linseed Oil

to permit the complete dissociation into cementite and pearlite, and we find formed the intermediate break down of austenite, known as martensite. If the cooling be intermediate in its speed between extremely slow and extremely fast, we find intermediate microconstituents, troostite or sorbite. The correct

siderable size, different degrees of hardness are noticed from the outside to the middle.

The cooling medium used, its temperature and condition, also affect the rate of cooling. In order that a liquid present in large bulk may exhibit a good quenching power it is necessary that it should possess a high latent heat of vaporization, and that it be maintained at a temperature low enough to avoid too abundant formation of vapor.

In investigating numerous commercial quenching mediums which are in use in typical hardening plants, the following method was adopted by the author: A test piece of the dimensions shown in Fig. 1 was machined from a solid bar, and a hole drilled through the neck to within an equal distance from each side and the bottom of the test piece. Into this hole a calibrated, platinum-rhodium couple was inserted and the leads connected to a calibrated galvanometer. The test piece was then immersed in a lead pot, also containing a thermo-couple, to the point *A*, and the lead pot was maintained at a temperature of 1,200 deg. F. When the couple inside the test piece was at 1,200

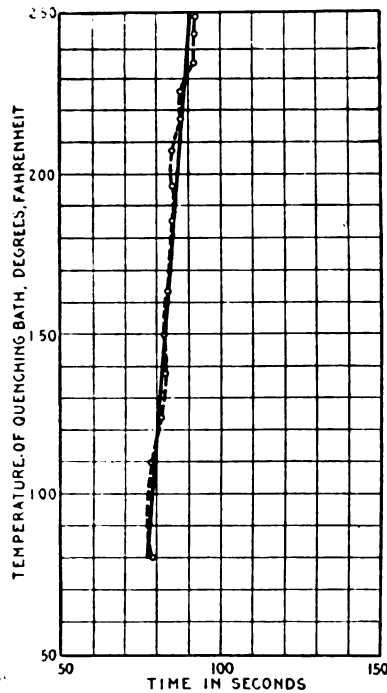

Fig. 7—Quenching Power of New Fish Oil

constituent, however, in a hardened steel is martensite, and to form this martensite the material must be cooled quickly. There are several degrees of "quickness" which at once suggest themselves. There is, however, a critical rate of cooling through the

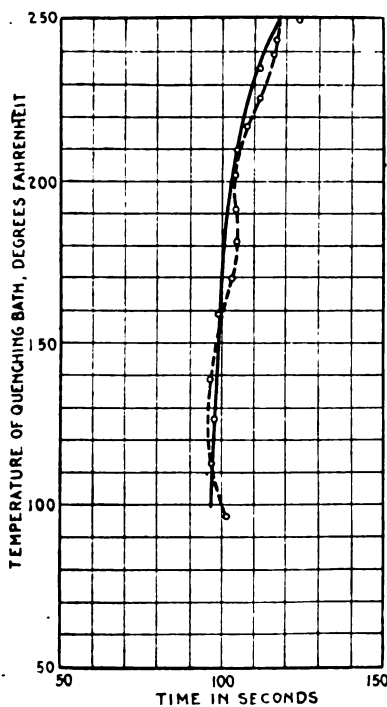

Fig. 8—Quenching Power of New Extra-Bleached Fish Oil

range which must be attained before the piece will be hardened. On quenching it is clear that the surfaces of the section are cooled and hardened first. If the mass being cooled is of con-

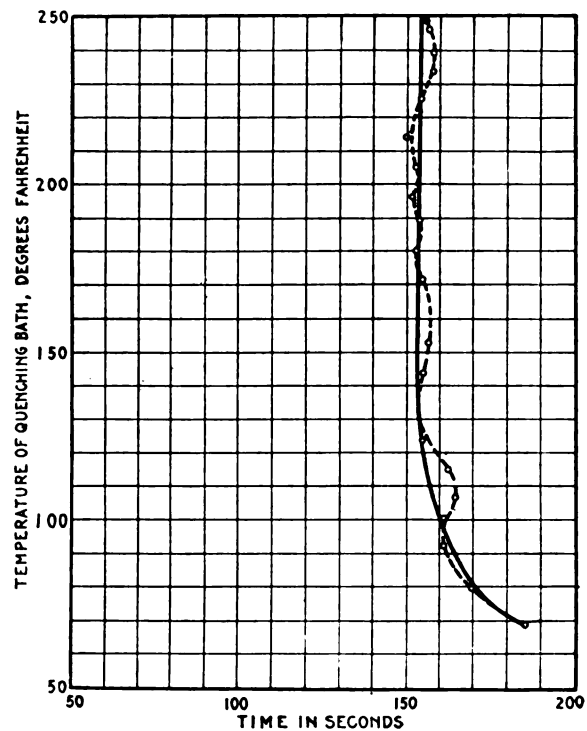

Fig. 9—Quenching Power of No. 1 Dark Tempering Oil

deg. F., and the couple in the lead pot read 1,200 deg. F., the test piece was removed and quenched to the point *B* in 25 gal. of the quenching medium under consideration. At the start the quenching medium was maintained at room temperature. The time in seconds that it took the test piece to fall from a temperature of 1,200 deg. F., to a temperature of 700 deg. F., was noted by the aid of a stop-watch. Immersing the test piece in the quenching medium raised the temperature of the medium. The test piece was then replaced in the lead, heated to 1,200 deg. F., quenched in the medium at this higher temperature and the time again taken with the stop-watch. These operations were continued until the quenching media, in the case of oils, had attained a temperature of about 250 deg. F. The results obtained, time in seconds for a fall from 1,200 deg. F. to 700 deg. F., were plotted against the temperature of the quenching medium and a series of curves of the type shown in Figs. 2 to 14, inclusive, were obtained.

A consideration of the results is interesting. Pure water (Fig. 2) has a fairly constant quenching rate up to a temperature of 100 deg. F., where it begins to fall off. At 125 deg. F. the slope is very marked. Brine solutions (Fig. 3) have both

a quicker rate of cooling and are more effective at higher temperatures than water.

As is well known the oils are slower in their quenching powers than water or brine solutions, but the majority of them have a much more constant rate of cooling at higher temperatures than

rates may well account for different results from the same steel in different shops, or in the same shop due to change of oil used.

It has been known for some time that different masses of the same material on being quenched under like conditions gave varying physical properties, but it is only within recent years

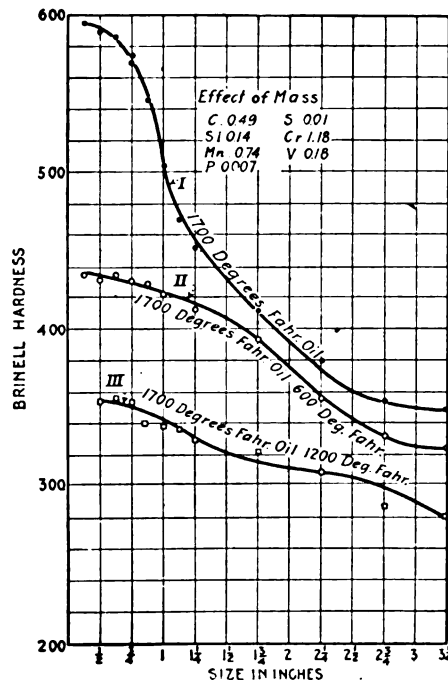

Fig. 10—Chrome-Vanadium Steel Quenched in Oil

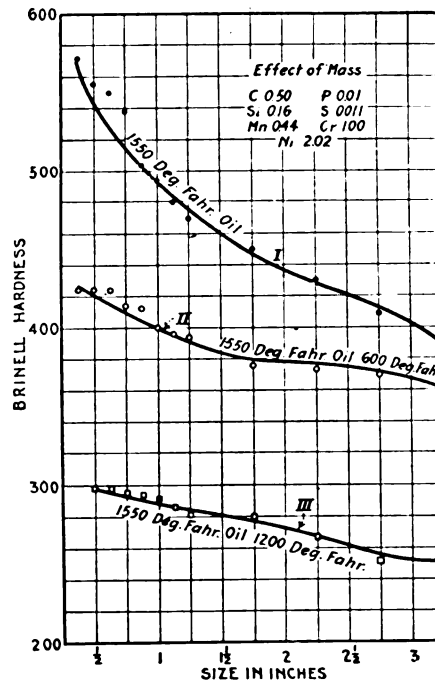

Fig. 11—Nickel-Chrome Steel Quenched in Oil
Effect of Mass Upon Brinell Hardness

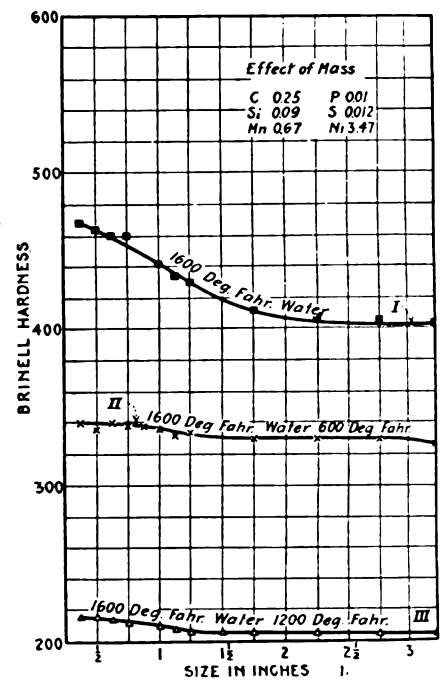

Fig. 12—Nickel Steel Quenched in Water

water or brine. The curve shown in Fig. 9 is for a thick viscous oil somewhat similar to cylinder oil. It is particularly interesting in that it has slower quenching ability at low tempera-

that the quantitative effect has been measured. The authors give below a few results, which, although obtained several years ago, are printed for the first time. Test pieces 4 in. long were made from the same ingot in sizes increasing 1/8 in. in both breadth and thickness. The smallest was 3/8 in. square and the largest 3 1/4 in. square. Three ingots of different type analyses

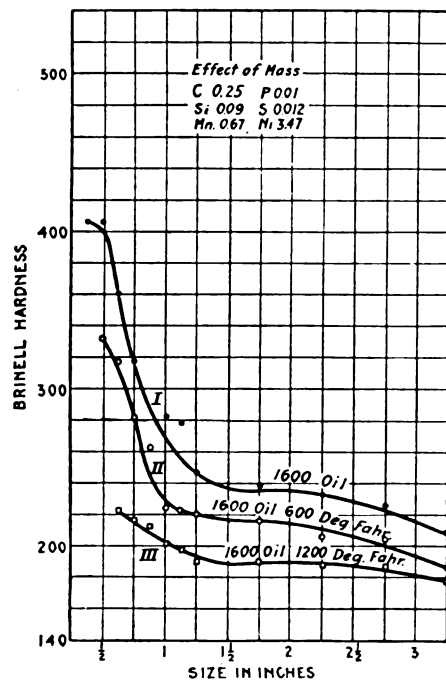

Fig. 13—Effect of Mass Upon Hardness; Nickel Steel Quenched in Oil

tures than at higher temperatures. A comparison of curves in Figs. 4 and 5 show the variation in quenching power of the same oil due to continued service. The difference in quenching

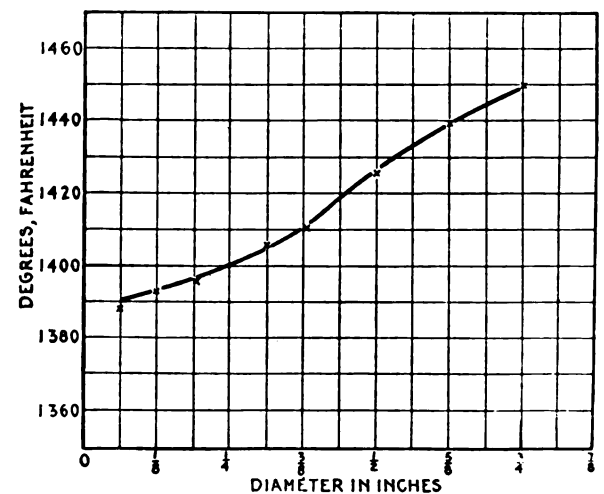

Fig. 14—Temperature-Size Curve for Hardening Tools

were chosen and a series of test pieces made from each. The test pieces were heated in a semi-muffle furnace to a constant temperature for each type of material, quenched, and the Brinell hardness test made. Each series was then drawn to 600 deg. F. in a salt bath and Brinell tests again taken and then reheated to 1,200 deg. F. in a salt bath and Brinell hardness tests again run. The results are graphically shown in Figs. 10 to 13, in-

clusive. Brinell hardness being plotted against test piece size. It will be noted that the smaller the sample the greater the figure of hardness, indicating that the smaller sections are cooled with greater rapidity than the larger, and hence more hardness is developed. The same agencies are at work in tool steel; the larger the mass the smaller the depth of hardness when quenched under similar conditions. For steel of constant mass, the higher the temperature, the greater the rate of cooling.

In order to produce the same amount of hardness in a small and large section it is necessary to heat the larger section hotter than the smaller. The authors were recently confronted with the problem of finding out the correct temperature for hardening tools made from the same steel in sizes varying from 1/16 in. diameter to 3/4 in. diameter. The temperature-size curve shown in Fig. 14 was finally adopted. In other words, a 3/16 in. round will harden at 1,395 deg. F., while a 3/4 in. round bar should be treated to 1,450 deg. F.—a difference of 55 deg. F.

Time and Degree of Drawing Temper.—After the hardening operation has been safely performed, the next important step is that of drawing the temper. This operation is necessary for two important reasons: The relieving of abnormal strains set up due to the quick contraction or expansion, and the breaking down of the extremely hard and brittle structure of the quenched steel. Expensive tools such as broaches, dies, etc., actually burst and fly apart due to the fact that the strains set up in hardening are not relieved by drawing the temper soon enough.

Standard 1/2 in. round A. S. T. M. test pieces were quenched from constant temperature in the same medium, and the temper drawn in the same salt bath at constant temperature for five minutes, fifteen minutes, etc.

Elastic limit	Maximum strength	Elongation	Reduction	Brinell	Remarks
228,750	260,137	2.5	425	1550-oil-800 deg. F. 8 min.
201,125	214,562	11.6	45.4	390	1550-oil-800 deg. F. 20 min.
175,000	183,187	12	49.35	340	1550-oil-800 deg. F. 40 min.

Each of the results in the table is the average of four closely agreeing checks, and they show that time at the drawing temperature has a marked effect. The greater the initial hardness of the piece, the more marked is the effect of drawing the temper. By referring to Figs. 10 to 13 inclusive the actual values in Brinell hardness are shown. The piece of 0.25 carbon nickel, 5/8 in. sq., quenched in oil, shows a Brinell of 360; drawn to 1,200 deg. F., a Brinell of 223. The per cent decrease in hardness is 61. The piece 3/4 in. sq., quenched shows a Brinell of 208; drawn to 1,200 deg. F., Brinell 183; only 13 per cent decrease.

The tendency of steel is to become spherical by repeated quenchings. Law, working with a square piece of tool steel 3 1/2 in. by 1/2 in. by 1/2 in., quenched it 550 times and at the end of this work the piece was nearly round in cross-section. The ratio of length to diameter had changed from 3 1/2 : 1/2 to less than 2:1.

Many years ago, one of the authors made several hundred hardening experiments and several thousand measurements to study the change of shape. The materials used were cylinders of steel and taps. Crucible steel alone was examined and the following variables were considered: The effect of original form or diameter upon the diameter after hardening; the influence of carbon on change of form; the influence of initial temperatures at quenching; the influence of length of time of heating; the influence of repeated hardenings, and the effect of annealing previously hardened steels, upon change of shape in rehardening. Obviously when plain cylinders of steel are considered, there are four changes of shape possible; expansion in length and diameter, contraction in length and diameter, expansion in length and contraction in diameter, and contraction in length with expansion in diameter.

Under the influence of the variable conditions mentioned above, all four changes were actually produced. Steel was also found which expanded in length on first hardening and contracted indefinitely thereafter on repeated hardenings. Another steel expanded in length on two hardenings, and contracted on

the next two. In a variable carbon series of steels from 0.50 to 1.33 per cent carbon, the magnitude of the change in length after four hardenings, increased as the carbon increased. For the same series it was noted that the volume changes were greater when hardening annealed rather than unannealed bars. The increase in length is greater the higher the hardening heat for all carbons. The point we wish to emphasize strongly is that it is variable conditions that give variable results. It is only under varying conditions of heat, size, time, composition, etc., that the results vary. Above the decalescence point, the coefficient of dilatation increases proportionately with the carbon and for all carbon percentages the rate of dilatation increases with the temperature. Resulting changes of form are conditioned by the original proportions of the piece quenched, by its chemical composition, by the temperature from which it is quenched, and within certain limits by the time of heating. Hardness, brittleness, change of form and liability to crack, generally speaking, increase with the carbon content and the temperature and time of heating.

Constant conditions are not always attainable. The maker of steel cannot control conditions in his customer's shop and the customer cannot control conditions in the steel plant and the human element must be considered in both.

Furnaces and Methods of Heating.—Much has been said regarding the superiority of gas furnaces over oil furnaces and vice versa. The fuel used is immaterial for good practice so long as the following points are taken care of: The furnace and hearth should be of sufficient size so as not to be affected materially in temperature by the introduction of the parts to be hardened. The furnace should heat at a uniform rate. The furnace should be of uniform temperature over its entire hearth. The furnace should be run under neutral, or reducing, conditions. A good rough test for this is the introduction of a piece of wood or paper upon the hearth. If the paper or wood burns, the atmosphere is oxidizing; if it chars, reducing or neutral. The temperature control must be at all times exact, and it must be possible of exact duplication on repetition work.

A blacksmith's fire is satisfactory under good handling, but the difficulty is the fact that for constant work it is too exacting on the operator and requires too many manipulations to secure uniform and continuous results. To expect uniformly good and consistent results from a hardener whom you have not provided with adequate or suitable equipment is unreasonable. When the question of good equipment in the way of furnace, quenching arrangements and mediums, pyrometers, etc., has been satisfactorily taken care of, your hardener still has plenty of variables to contend with which are beyond his control.

GUARD FOR VISE TAIL PIECE

BY W. B. MIDDLETON

Roundhouse Foreman, Atlantic Coast Line, Rocky Mount, N. C.

It is usually a difficult matter to keep employees from disfiguring the tail pieces of bench vises about the shop by using them as anvils for light riveting and small jobs of chipping

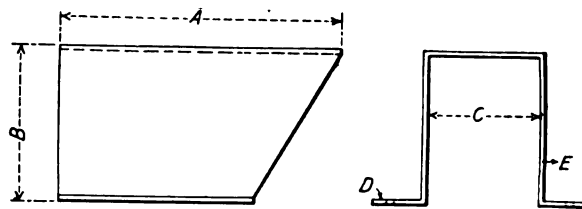

Guard for the Protection of Vise Tail Pieces

on odd shaped pieces. To protect the tail pieces from injuries received in this way, which often interfere with the proper operation of the vise, the simple guard here shown has proved

of considerable value. It is made of 3/16 in. scrap iron and is slipped over the tail piece of the vise, where it is secured to the bench with bolts or lag screws.

DOES MODERN APPRENTICESHIP PAY?*

By L. L. PARK

Superintendent of Apprentices, American Locomotive Company

What is the advantage of apprentice training by shop instructors and by shop schools?

By comparing the work of apprentices with that of specialists and mechanics employed at random, it has been found that less work is spoiled by the apprentices than by the others. This is due in part to the greater thoughtfulness developed by the apprentice scheme, which has taught the young man to use his head as well as his hands.

Where the use of drawings is involved, the school-trained apprentice is less likely to misread them and he is apt to use better judgment in the following of directions. If taken soon enough after leaving school and followed up closely, the apprentice has less to "unlearn" and it is easier to teach him to be accurate and careful than is the case if he is picked up later and taught to specialize. He needs, however, more attention at the start than is likely to be given him when there is no special instructor.

Apprentices also are less severe on machines and develop greater care in the handling of tools. Of the total cost of machine maintenance from breakage due to carelessness, only a small percentage is chargeable to apprentices. They are more apt to have a bigger notion of the value of machines and do not take so many chances as do the others, although they soon learn to work the machines to their safe capacities.

By systematic instruction in the care and handling of machines and the mathematics relating to their operation, the apprentice has been found to be more resourceful in the handling of his work than is his fellow employee, and he can often "make good" on work where others have failed. Cases might be cited where specialists have repeatedly been unable to produce their rate on certain machines and jobs, while apprentices who have taken hold of the same work on the same machines have made an excellent showing. These results cannot be produced by a method which leaves too much to the initiative of the worker, but initiative plus training will accomplish them.

An apprentice scheme which permits apprentices to work on a piece-work basis during the larger part of their course will enable the future mechanic to adjust himself more readily to the piece-work system than do those who must start as piece-workers or who change suddenly from a day-work to a piece-work plan. Here the instructor plays an important part and shows the boy why he fails at first to make good and enables him to discover a better method rather than turning down the job as hopeless. The school also helps to develop originality and gives the boy greater self-reliance.

A still further advantage of modern apprenticeship is the flexibility with which vacant places in the shop may be filled. A man is out sick and an important job is standing. The instructor is here able to transfer to that machine an apprentice who has handled similar work, and, if he needs attention in getting started, it is the instructor who stands by and gives the needed help.

One of the most important advantages of the modern plan is the good feeling which is usually established between the employee and the employer. The instructor has been chosen because of his ability to deal wisely with boys, and he is able to straighten out many difficulties which ordinarily would cause friction, and the boy is often made to feel that he is getting a square deal where the busy foreman might have left half-adjusted matters which would have led to lasting ill-feeling. The atten-

tion given the apprentice during his term of service also helps to make him feel that his employer is interested in his welfare, and the system brings to the boy influences which give him a broader view of industry and its problems.

It is sometimes stated that too much attention makes apprentices feel that they are privileged characters, but it has been our experience that, with wise direction, there is less danger from this cause than from the spirit which usually accompanies too little attention.

The old system of leaving apprentices to the care and instruction of the foreman may be satisfactory in a small shop, but in a large department it usually means failure for the apprentice scheme. Many foremen have said that "apprentices are a nuisance" when this method is tried. Few foremen have time to give personal attention to the boys, and the actual instruction must fall upon some one else. We have yet to find a foreman whose attitude toward apprenticeship has not radically improved when an instructor has been placed over the apprentices. The common complaint of having "too many" has, not infrequently, changed to a request for "more."

Where apprentice instruction is left to "the man on the next machine," the things taught are far from uniform and often wrong in their principle. Only by a supervising instructor can this teaching be standardized and brought up to date. The present importance of "safety first" makes doubly necessary the training of the apprentice from the very start in the habits of caution and carefulness. This can be done without any sacrifice of output if the proper attention is given to the learner.

If the apprentice is to be developed to the highest extent he must have more than casual attention. Our agriculturists have long been studying how to make most productive the soil from which their produce must come, but the manufacturer has been very slow to realize that the human element of industry needs cultivation to bring about its highest productive ability.

Not only has the well-planned apprentice course given better training to the boys learning the trades, but it has attracted to the trades boys of higher intelligence. Many bright boys leave industrial shops because they see no opportunity for advancement, no provision for their getting proper instruction and change. While it is true that most men specialize after learning their trades, it is unquestionably true that their broader training has made them better mechanics in the special line which they have chosen.

While it is possible to make an apprentice school unnecessarily elaborate, a school which teaches the essentials of shop practice and the theories and mathematics underlying shop methods cannot but prove of benefit to an apprentice. It is more economical to teach a principle once to a class of twenty than to tell it twenty times to individuals in the shop. It has been found that the time spent in day classes is not a loss from the shop's viewpoint, but that, because of the greater interest and the change of work, the boys will accomplish as much on days when an hour is spent at school as they will when there is no school to attend.

As might be inferred from the foregoing, the shop supervisor and the instructor are the keys to modern apprenticeship. Some apparent failures of the system have been really failures of the supervisor or instructor, and the greatest of care is needed in the selection of these men (or man, if both positions are combined). Not every good mechanic can qualify as an apprentice instructor; he must have natural ability to teach and he must understand boy-nature, and be gifted with patience and tact as well as firmness. Too much emphasis cannot be placed upon this matter, for the investment will pay or lose, dependent upon the selection of the men who lead the work.

STEAM BOILER SPECIFICATIONS.—It is reported that the steam boiler specifications furnished by the London Guarantee & Accident Company, Ltd., Chicago, will conform to the standard specifications of the American Society of Mechanical Engineers.

*From The National Association of Corporation Schools Bulletin.

GRINDING WHEEL PROTECTION

BY E. T. SPIDY

Assistant General Foreman, Canadian Pacific, Winnipeg, Man.

The grinding wheel guard shown in detail in the engravings was designed with two objects in view. The first was to provide an adequate means of protection for the wheel and the second to collect the fine particles of grinding dust that are thrown off into the air by all grinding wheels.

The guard consists of a box casing and a cover and is fitted

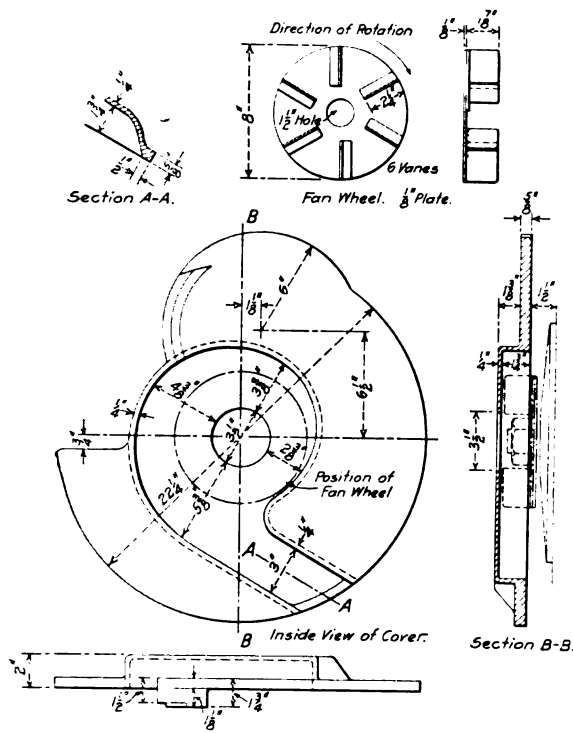

Cover and Fan Used to Collect Dust from Emery Wheels

with an adjustable slide which is let down as the wheel wears. The slide will accommodate wheels ranging in diameter from a maximum of 20 in. to a minimum of 10 in., which is large enough so

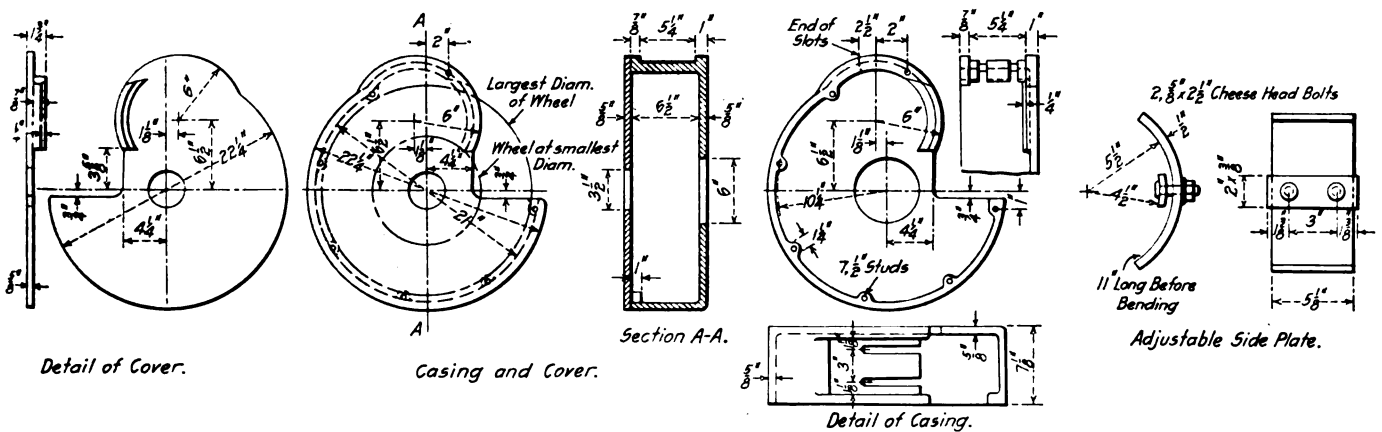

Details of Grinding Wheel Guard, Showing Plain Cover

that but one size of guard is required for all the general purpose wheels in a railway shop. The casing is made of cast iron and requires no machining beyond the drilling of bolt holes for fitting it together.

The arrangement for collecting dust consists of a small fan, the construction of which is shown in one of the engravings. This is attached to the outside collar of the grinding wheel and occupies a recess cast in the cover. A hole is cast in the casing

so that a pipe may be attached and the dust conducted away from the wheel into a water box if desired. The draft induced by the small fan has proved to be sufficient to drive a large part of the dust out through the pipe, and it does not use enough additional power to require any change in the size of belt. On grinding wheels where the amount of dust is small or where it is not objectionable, the casing is provided with a plain cover and the fan is not used.

MEASURING EFFICIENCY*

BY H. L. GANTT

The widespread interest in the subject of management which has grown up within the last few years, has, I believe, a deeper significance than is at first realized. The readiness with which employers of labor have been willing to seek advice from almost anybody calling himself an "efficiency engineer" is hard to understand on any theory except that many employers realize that they are not operating their plants as well as they should be operated; and the fact that so many so-called "efficiency engineers" with but little experience or training have been able to accomplish results apparently well worth while, seems to bear out the theory that the art of management as practiced by many employers is still in a very crude state.

To be sure, many efficiency engineers have become discredited and gone out of business, but others have entered the field, and apparently the number in active practice is greater today than ever before. It would be impossible for such a large body of men to find employment unless at least a fair number of them were doing some good.

It is a fact that the agitation of the subjects of management and efficiency during the past few years has caused many employers to study their management problems very much more closely than heretofore, with the result that there has undoubtedly been a marked improvement in the efficiency with which industrial operations as a whole are being conducted. But in spite of this increase in efficiency, the greatest of our industrial problems, the relation between the employer and the employee, seems but little nearer solution. As a matter of fact one of the most efficiently run plants I have ever seen promises, unless my theories are all wrong, to widen the gap between employer and employee. The solution lies deeper, and before we can make

any real progress toward it, we must revise some of our fundamental conceptions.

With the growth of competition within the last 20 years the necessity for some knowledge of costs became evident, and the manufacturer turned to the accountant for a system of finding costs. The present system of railroad accounting had been de-

*Abstract of a paper presented at the annual meeting of the American Society of Mechanical Engineers, held in New York, December 1-4, 1914.

veloped, and certain ratios accepted as measures of efficiency of operation; notable among them the ratio of operating expense to total income. The financier demanded a similar simple measure of the efficiency for an industrial plant. The cost accountant promptly gave him what he called the ratio of non-productive to productive labor, which he said should be low for good management. By non-productive labor he meant salaries of all kinds, and all other labor that could not be charged directly to an order, including miscellaneous labor such as watchmen, sweepers, truckmen, etc. By productive labor was meant simply that labor which could be charged directly to an order.

While the ratio of operating expense to total income may be a fair measure of efficiency in a transportation company, the ratio of non-productive to productive labor is not only not a fair measure of the efficiency of operation in a manufacturing plant, but is often exactly the reverse. The widespread use of this ratio as a measure of efficiency has been more effective in producing inefficiency than any other single factor except the oft-repeated statement that you must have low wages if you would have low costs. Until these two fallacies are absolutely discredited, we cannot expect a solution of our most serious problems.

Of these two fallacies, the second seems to be yielding gradually to the overwhelming mass of evidence against it. So many cases are now on record where the industrial engineer has increased output, raised wages, and at the same time lowered costs, that only those who are too conservative to investigate are still holding on to the old theory. With evidence of this kind at hand, it is safe to say that this fallacy will before long be entirely discredited. The other fallacy, that the ratio of non-productive to productive labor is a gage of efficiency, is so firmly rooted, however, that it is hardly to be expected that it will yield in the near future.

If any expense is really non-productive, contributing nothing to the end for which the factory was established, it should be eliminated. The salaries of the officers, foremen, janitors, truckmen, and laborers, as well as the money paid for taxes, insurance, or interest are necessary to the operation of the factory and therefore productive. I prefer to call all such expenses that have to be distributed indirect expenses, and those that are chargeable to specific orders direct expenses. The ratio referred to is thus more correctly described as that of indirect to direct labor, and to base any conclusions as to the efficiency with which a factory is run on it is misleading, often being productive of inefficiency rather than efficiency. I might give numerous examples to bring out this fact, including one where two men took the place of 16, and a daily direct wage of \$8 took the place of \$48, with but little increase of the corresponding indirect expense. The result was that the ratio for that shop became over double its former value with a marked reduction in the total cost. Needless to say, that the ratio theory in that plant is not regarded with the same reverence that it once was.

In plants where such results have been accomplished, those who have been accustomed to worshipping this ratio at once demand another idol in place of the one that has been so badly discredited. Inasmuch as the efficiency of the operation of a factory is made up of the efficiency of a great many independent operations, and is really indicated only by the cost of the various articles produced, there has not yet been found any easy way of indicating the efficiency without first getting the cost of the individual articles. Having been accustomed to an idol, however, both the accountant and the financier demand one, and are loath to give up the idol they have so long worshipped, no matter how badly shattered it may be. But when a reliable cost system has been installed, this idol becomes so badly discredited that even its most devoted high priests are obliged to abandon it.

In discussing cost systems, I wish to confine myself to the problem of how to get a true knowledge of the various items of labor and expense, both direct and indirect. This subject seems to have been given but scant consideration by the average ac-

countant, who has usually assumed it to be easy and devoted his energies to working out elaborate theories as to what should be done with the various items of expense. Inasmuch as I find that the information which the office gets of what the shop has done is, as a rule, not very reliable, I feel that it is far more important to get this information correct than to get up elaborate schemes for using it. We shall therefore confine ourselves to the consideration of what the essential elements of a reliable cost system are, and how to get an exact knowledge of them. These elements are a knowledge each day of (a) what was done the day before; (b) who did it, and (c) what was paid for it. It is necessary to check these items daily, for it is impossible to check them accurately after the lapse of any appreciable time.

It is comparatively easy to get a set of returns purporting to give the above information, but the real difficulty comes in knowing whether these returns are correct or not. The only sure way of knowing whether these returns are correct or not is to know beforehand (a) what should be done the next day; (b) who should do it, and (c) what should be paid for it.

When we have arrived at a condition under which we can plan our work in advance on these lines, we have the basis of a real system of management, in which we can promptly check what has been done with what should have been done, and know with certainty each day how we stand.

It is not my intention to go into details as to how this can be done, as the subject is too big for a paper of this character. However, as the criticism will be at once raised that the clerical work needed would be so great as to make it out of the question, in reply I may say that even in the most poorly run business, some attempt, either consciously or unconsciously, is made to control work on these lines. Moreover, we generally find that the more nearly the above ideal is approached, the more successful the plant is, and all will admit the desirability of such a system if it can be established without excessive clerical work. As a matter of fact the clerical work needed to operate the best systems of this type is decidedly less than that needed to operate any of the standard cost systems put in by chartered accountants.

It must be borne in mind, however, that during the process of installing the new system and training the employees to operate under it, the old system must be continued; and not until each function performed by the old has been taken over by the new can we drop the old entirely. During the process of installation, therefore, we must to a large extent operate two systems. This necessarily runs up the ratio of non-productive to productive expenses, and the accountant lifts up his hands in horror at the expense of the new system. If at the same time the new system is successful in reducing the productive labor, the ratio is still higher, and the "showing" is still worse, even though the total cost is less. I therefore repeat that the first step to be taken before introducing a modern system of management is to eliminate the ratio of non-productive to productive labor as a measure of efficiency. The establishment of the fact that total cost is the only reliable guide will do much to pave the way for an improved system of management.

The first step in accomplishing this is to revise our ideas as to the functions of a cost system. In the past the principal function of a cost system, besides indicating a limiting selling price, has been to enable those in financial control to criticize those operating the factory. These criticisms are usually from one to three months late, and are so general in their character as to afford, as a rule, no guide whatever by which the superintendent can be governed. Such a system is too often most highly prized for its worst defect, namely, that it enables those in financial authority to criticize without taking any responsibility whatever for showing how to do better.

If, instead of making the function just described the prime one, we raise to equality with it, a function which requires the system to furnish promptly, day by day if necessary, exact in-

formation of what has been done and what the expenditure has been, we shall find that its most valuable function becomes, not finding costs, but furnishing the superintendent with information which helps him to reduce costs. In other words, before we can expect to get any great benefits from the newer managerial ideas, we must readjust our ideas of the functions of the cost accountant, who must become the servant of the operating executive as well as of the financial executive.

As long as the cost accountant is simply a critic, he may be called non-productive, but when he furnishes the superintendent with prompt information which enables him to reduce costs he becomes productive. Promptly detailed information of what is being done each day, furnished in such manner as to be readily compared with what has been done, and what can be done, is the best method of measuring efficiency.

COMBINATION RIVET SET

BY H. L. LOUCKS

Machine Shop Foreman, Erie Railroad, Dunmore, Pa.

Considerable difficulty has been found in securing a rivet set which would satisfactorily withstand the service met in various classes of railroad shop work. After having experimented with methods of hardening and treating steel without success the combination set shown below was finally developed. After having been severely tested specially in car shop work, operating on 100 lb. to 110 lb. air pressure, it has been found to have a life of practically double the number of rivets usually driven with the solid set.

It consists of four parts: a socket, a cup, a dowel pin and a retaining spring. The socket may be made from a worn or

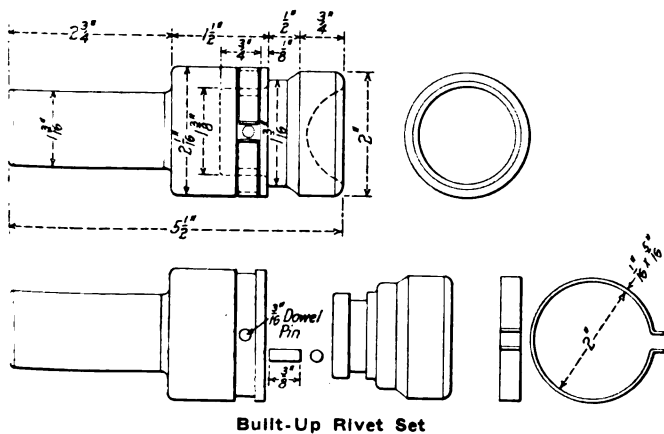

broken solid set, annealed and turned to the dimensions shown in the drawing. The cup is made from old locomotive tire steel forged and finished in a lathe.

The use of a separate cup and socket results in a distribution of the stresses which overcomes the tendency of the solid sets to break at the shoulder between the stem and the head. The socket lasts indefinitely and new cups may be provided as required at a cost not exceeding one-half of that for new solid sets, the steel for which is expensive.

FORMIDABLE LOOKING FORMULAS.—Many engineers will go down without a struggle before a formula which has a logarithm, entropy or a sine, cosine or tangent in it. It is just as simple to look up one of these quantities and to substitute the value given in the table for the letters of the formula as it is to hunt up the steam temperature corresponding to a given pressure, or the area corresponding to a given diameter, and the same book which contains the tables of the properties of steam and of circumferences and areas will usually have the other things, too.—Power.

BOILER WASHING AND FILLING SYSTEM FOR SMALL ROUNDHOUSES

BY WILLIAM WELLS

The fact has been fairly well established that the use of hot instead of cold water for washing out locomotive boilers will produce better results, as regards the effect on the boiler structure, the amount of sediment and scale removed, and the time consumed in the washing operation. The filling of locomotive boilers with clean hot water also has allowed the movement of a locomotive out of the roundhouse within 30 minutes after the filling operation was completed, a marked reduction in the time required for obtaining the necessary amount of steam for moving the engine when cold water was used, and one which has an important bearing on the prompt handling of locomotives at terminals. While the results obtained have been in the main satisfactory, and the expense of the well designed boiler washing and filling systems on the market generally has been justified for the larger terminals, the first cost of these systems has prevented railway officers from authorizing their installation in the small roundhouses, located at points where the number of locomotives handled daily and the importance of the traffic would not seem to justify this expense.

Most small roundhouses require the installation of a steam boiler equipment for the drafting of locomotives, operating water pumps, air compressors and a stationary engine, the exhaust steam from which contains sufficient heat, if properly utilized to provide an adequate supply of hot water for boiler washing and filling purposes where the requirements of the engines handled are not in excess of the heat contained in the steam available. As exhaust steam at one pound pressure has a total heat content of 1,152 B. t. u. per pound in comparison with a heat value of 1,192 B. t. u. for steam at 125 lb. pressure, it will be seen that exhaust steam which usually is passed to the atmosphere through the exhaust and is therefore wasted, contains within 3 per cent of the heat which is contained in steam at the higher pressure.

The accompanying drawing shows a design for a boiler washing and filling system which uses exhaust steam for heating the water and from which may be obtained results which approach those possible with the larger systems to a closer degree than may be obtained by any form of sump. The system has been designed with the idea of getting the greatest results with the least expenditure of money for plant equipment, and the only apparatus necessary over that required for a roundhouse with a washout pump is the feed water heater, the storage tank and the necessary piping, valves and fittings for the hot water line. The feed water heater may be of simple design, possible of manufacture without difficulty in any railroad boiler shop; the storage tank may consist of one or more condemned horizontal tubular boilers with the tubes removed, and properly fitted up to contain water.

In the drawing, *A* is the storage tank containing a supply of hot water for boiler washing and filling purposes, *B* is a small feed water heater, of the open type, made of either cast iron or steel, for heating the water, *C* is a steam pump of the ordinary reciprocating type for supplying the hot water under pressure and circulating the water in the storage tank through the heater when the locomotive boilers are not being washed out or filled. Instead of using the pump *C* for circulating the water a separate pump of smaller capacity may be used with equally good results and possibly no increase in the amount of steam required for circulation. The thermostat-operated valve *D* may be installed or omitted as desired, its function being to admit live steam to the heater when the temperature of the water entering the heater falls below a certain predetermined point due either to a deficiency of exhaust steam or excessive use of water from the system. The boiler feed pump *E* is of the reciprocating type and may be dispensed with if the stationary

boiler pressure is equal to or less than that used for washing and filling locomotive boilers.

In the operation of the system, water is maintained at a constant level in the storage tank *A* through the action of a float operated valve in the cold water supply connection. Exhaust steam is admitted to the feed water heater, after having all oil removed by a separator provided for the purpose, and comes in contact with and heats the water from the storage tank entering the heater through the water supply connection which in the drawing is a by-pass from the discharge line of the boiler washing and filling pump. By a continuation of the above process the water in the storage tank increases in temperature until the boiling point is reached, or until the water is used for either washing or filling the boiler through the pump.

In a small roundhouse the number of locomotive boilers re-

duced approximately 1 per cent for subsequent use or a sufficient quantity to increase the temperature of the water required to fill the tank from 60 deg. to 80 deg.

Calculation shows that the amount of exhaust steam at one pound pressure required to raise the temperature of the refilled tank to 180 deg. would be approximately 5,550 lb., and the time required about 6 hr. Based on a uniform use of the steam for heating the water, approximately 900 lb. per hour would be used, or the amount obtained from an ordinary 25 hp. slide valve engine operating continuously at full load. The supply of feed water for the stationary boilers should be taken from the feed water heater direct as the temperature of the water in the heater will be uniform and always higher than that in the storage tank. In this connection it should always be remembered that the amount of coal required for steam making purposes is

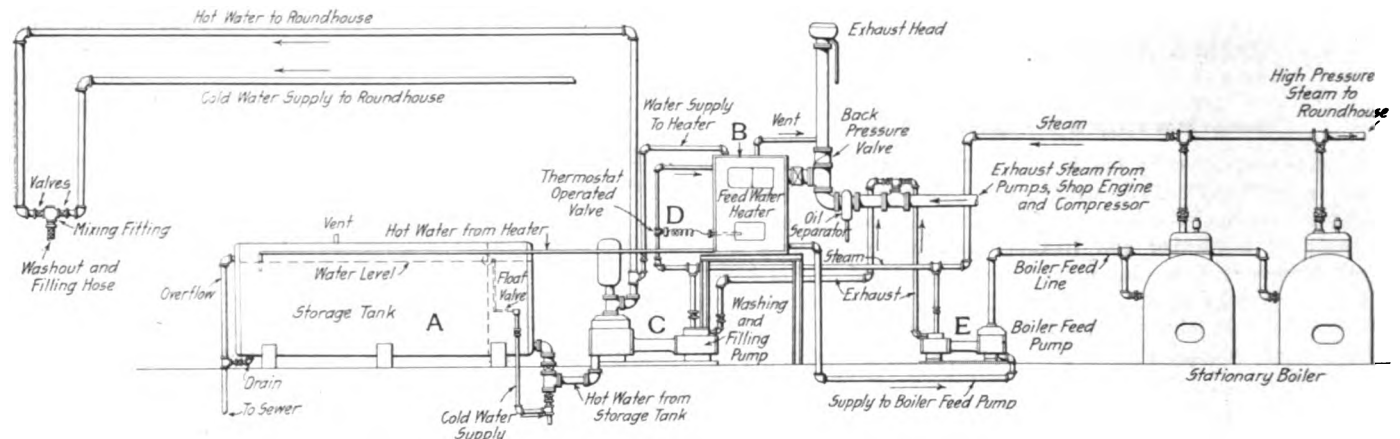

Hot Water Washing and Filling System for Small Roundhouses

quiring washing out and refilling usually does not exceed three in a period of 24 hr., and with an allowance of 50 min. per engine for the washing operation and 20 min. for filling, there remain practically 20.5 hr. out of every day for building up the temperature of the water in the storage tank. Dividing the time the system is not delivering water for washing and filling by the number of engines handled, an average of about 6 hr. per locomotive handled for heating the water in the storage tank, is obtained. Results from service tests on two modern boiler washing and filling systems installed in large roundhouses show that an average of 4,800 gal. of washing water and 2,600 gal. of water for filling were required per engine handled, the number of locomotives having their boilers washed out and refilled during the 24-hour period of the tests being 14 in one case and 10 in the other.

On account of difficulty experienced with the use of water at a temperature over 120 deg. for washing out purposes, cold water must be admitted in the pump discharge line to obtain the desired temperature. Assuming that 4,800 gal. of water is required per engine washed out and a temperature of 180 deg. in the storage tank—a figure which may be easily obtained by separating the washing and filling operations on different engines as much as possible—it will be necessary to admit about 2,400 gal. of cold water at 60 deg. to the pump discharge to obtain the 120 deg. working temperature.

Using the above data as a basis, the capacity of a storage tank for washing out and filling three boilers per day of 24 hr. should be approximately 6,000 gal., or the water contained in one tank 16 ft. long by 96 in. diameter, or two tanks 16 ft. long by 72 in. diameter. A storage tank of this capacity would provide sufficient water for the washing out and filling of one boiler, and at the end of both operations the temperature would be approximately 80 deg., based on the admission of cold water equal in quantity to that used. As an alternative proceeding, by shutting off the cold water supply to the storage tank while washing and filling, 180 deg. water would be available during

reduced approximately 1 per cent for each 10 deg. increase in the feed water temperature, a point not to be lost sight of in the operation of any type of boiler feed water or washing and filling system.

RECLAIMING WORN LUBRICATOR CHOKE PLUGS

BY F. W. BENTLEY, JR.

Some time ago the air brake department was confronted with a shortage of new lubricator choke plugs for the bull's eye type of lubricator. A considerable number of these plugs, removed because of an enlarged condition of the restricted passage in the end, had been retained. In order to reclaim them a wood holder

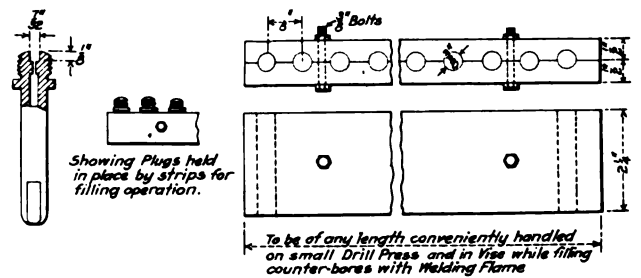

was made in which 15 or 20 plugs could be secured at one time. The chokes were then countersunk with a 7/32-in. drill, care being taken that the drill did not penetrate the restricted portions of the oil passages. These apertures were then filled with brass by the use of the acetylene welding flame, the work being performed much like a soldering operation. The holder was then taken to a small drilling machine and 1/32-in. holes drilled through the solid ends of the plugs. This is economical even where but a small number of plugs are to be reclaimed.

NEW DEVICES

POWER PLANT OIL FILTER

The oil filter shown in Fig. 1 was developed in order to secure a filtering medium of increased efficiency and an arrangement of the plant which would make possible large filtering



Fig. 1—Oil Filter Having Capacity of 100 Gal. to 200 Gal. Per Hour

capacity in a small space. The device, which is known as the Peterson power plant oil filter, consists essentially of two parts placed in the same case. The first is the precipitation com-

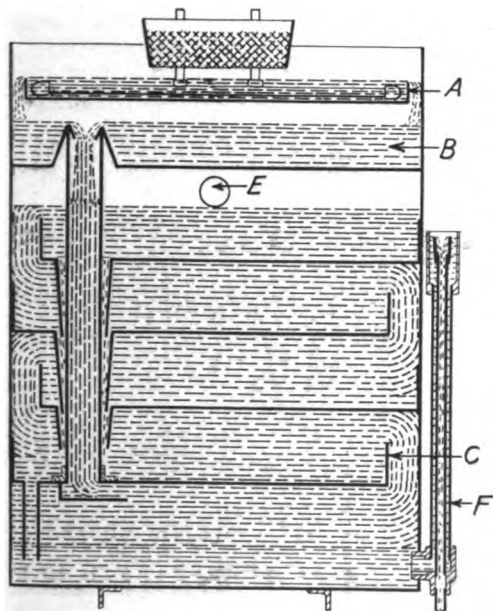

Fig. 2—Method of Operation of the Precipitation Compartment

partment in which water and the coarser particles of solid matter are removed; the second is the filter proper. Surrounding these two compartments is the storage space for filtered oil.

The dirty oil enters the filter through a strainer box, passing down through a removable strainer which catches large pieces of foreign matter, such as waste. A heater tray *A*, is located directly below the strainer, where the viscosity of the oil is reduced before it overflows into the compartment *B*. From this compartment the oil flows through a funnel and vertical conductor shown in Fig. 2. As it emerges from the vertical conductor the oil is spread out below the tray *C* by means of a baffle, and under the action of the head which accumulates in the vertical conductor the oil is forced to take a zigzag upward path, passing under and over several trays in its course. The level of the oil in the top tray is maintained constant by a skimmer shown at *D* in Fig. 3, the overflow from which passes to the filter compartment through the opening *E*.

As the oil flows over the trays the water separates and collects in the bottom of the trays, from which it is by-passed di-

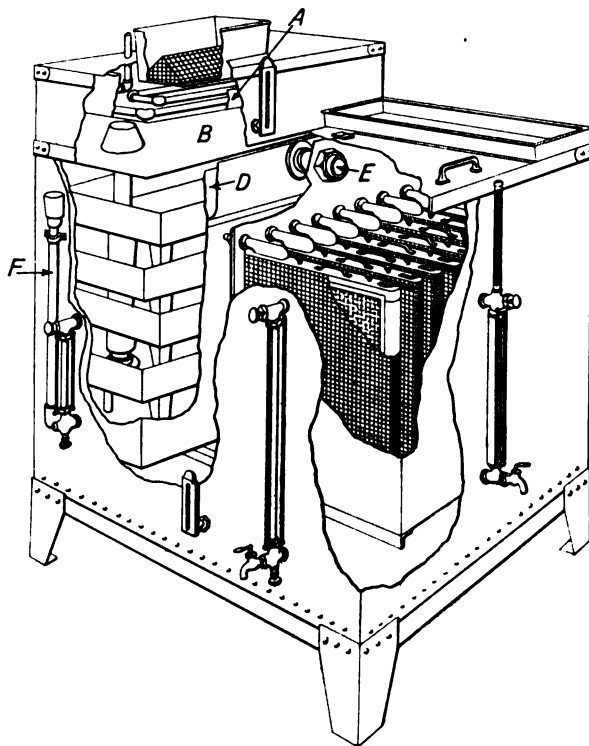

Fig. 3—Arrangement of the Parts of the Peterson Oil Filter

rectly to the bottom of the precipitation compartment by means of funnels surrounding the vertical oil conductor. These prevent the water from coming in contact with the moving oil after having once been separated. The water is automatically removed from the precipitation compartment by means of an overflow tube *F*. This consists of two concentric pipes, the outer one of which is connected at the bottom to the water chamber while the inner one leads to the drain. A funnel is threaded to the upper end of the inner pipe by means of which adjustment may be made to provide for oils of different specific gravities. The overflow operates on the U-tube principle; the column of water in the outer pipe balances the column in the filter, composed partly of oil and partly of water. The oil being lighter than the water, the top of the overflow is slightly lower than the level of the oil in the precipitation compartment. As more water collects in the bottom of this compartment the relative weight of the two columns is changed, that within the precipitation compartment becoming heavier, and the level in the over-

flow tube is raised until water flows over the top of the funnel into the drain. A low water level is thus automatically maintained in the precipitation compartment.

The filtering compartment contains nine non-collapsible filtering units, one of which is shown in Fig. 4. The oil passes from the outside to the inside of the filtering unit and then out through nozzles projecting through the wall of the compartment into the clean oil compartment. The nozzles fit into spring-actuated valves so that any unit may be withdrawn and cleaned without interfering with the continuous operation of the filter. When the unit is withdrawn this valve instantly closes and prevents unfiltered oil from flowing into the clean oil compartment. The filtering cloths are so arranged that they are free from folds or plaits, thus rendering effective their entire surface. They are placed in a vertical position, so that the slime and sediment collecting on the filtering surfaces continually works towards the bottom. The filtering units are thus largely self-cleaning.

No oil can pass to the clean oil compartment until the level in the filtering compartment reaches the outlets from the filtering

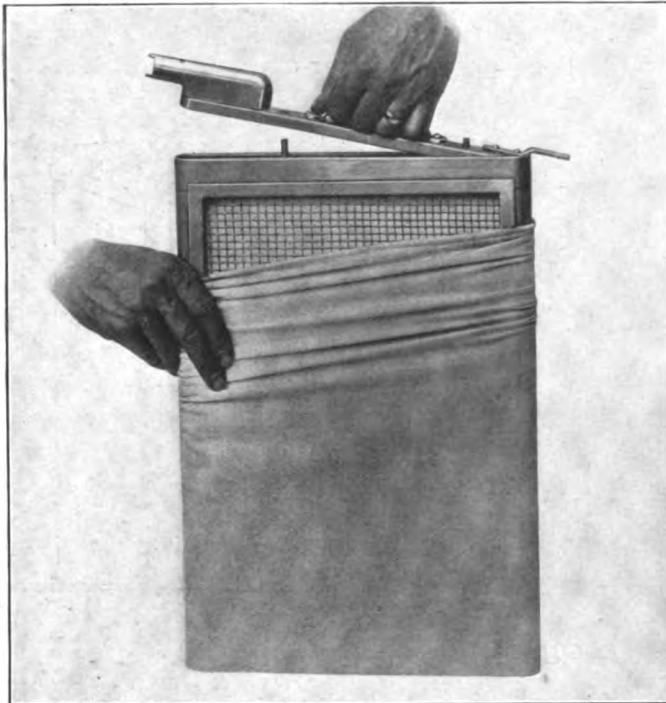

Fig. 4—Vertical Filtering Unit Removed from the Filter

units; as soon as a slight head builds up over the outlets the process of filtration commences and is distributed over the entire filtering surface, all of which is subjected to equal pressure. The head of oil over the filtering unit is shown by the indicator at the top of the gage on the front of the filter. When operating at normal rating this indicator should show a level of about three inches of oil. Space is provided, however, for carrying oil to a height of six inches, thus making possible the handling for short periods of a 100 per cent overload.

Other gages are provided to show the level of the oil in the storage compartment and the water level in the precipitation compartment. A thermometer shows the temperature of the oil in compartment B, thus enabling the proper regulation of the heater coil. Another thermometer shows the temperature of the oil in the clean oil storage compartment, and when necessary the oil is passed over cooling coils before it is returned to the lubrication system.

The filter body is constructed of No. 12 gage galvanized sheet steel reinforced with channels and angles. All joints are lapped and closely riveted and soldered. The only parts needing pe-

riodical attention are the filtering cloths, and these are readily cleaned by removing the filtering units, without interfering with the continuous operation of the filter. The filter here illustrated has a capacity of 100 gal. to 200 gal. per hour, this being the basic unit by the duplication of which plants of larger size are built up. These filters were recently placed upon the market by the Richardson-Phenix Co., Milwaukee, Wis.

MAIN RESERVOIR BALL JOINT CONNECTION

The accompanying illustrations show a ball joint developed especially for locomotive main reservoir pipe connections. Many engine failures are caused by the breaking of main reservoir pipe connections, due to vibration of the pipes, the effect of which is concentrated at the rigid connection in the reser-

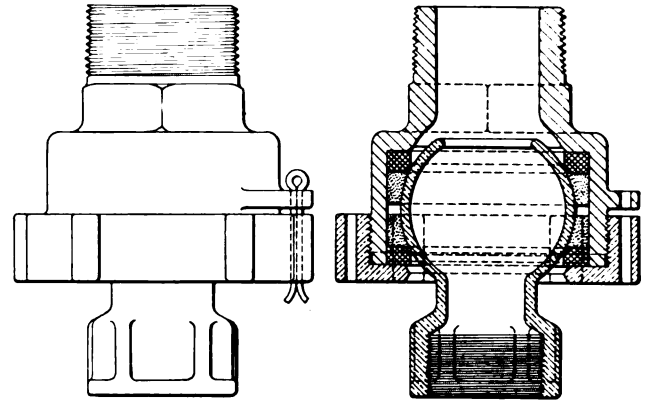

Details of Ball Joint Pipe Connection for Main Reservoirs

voir. The body of the ball joint is threaded and screwed directly into the reservoir and the end of the pipe is screwed into the ball member, thus relieving the threaded connections of vibration stresses.

The construction of the joint is shown in the engraving. The

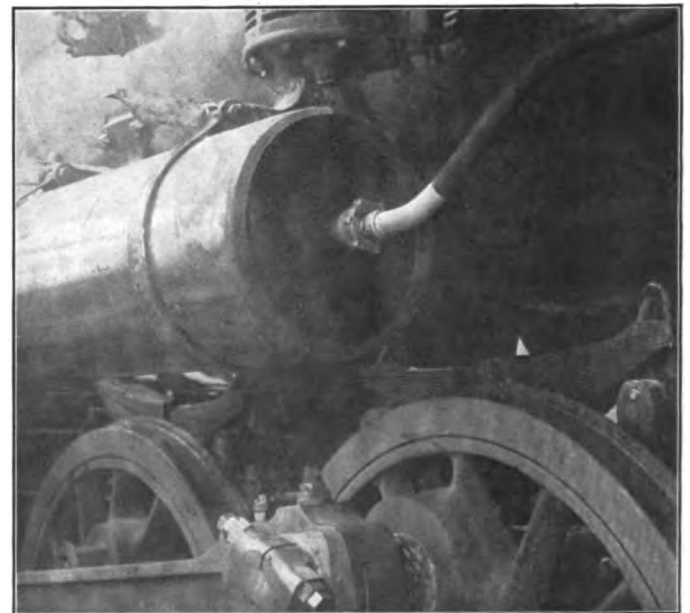

Main Reservoir Ball Joint Pipe Connection

body is made in the form of a cylindrical casing in which are placed two rubber packing rings and two hard babbitt retaining rings. The packing rings form the joint with the spherical

surface of the ball member and are held in position by a gland nut on the casing.

This joint was developed by the Franklin Railway Supply Company, 30 Church street, New York.

LOCOMOTIVE SAFETY VALVE

The accompanying illustration shows a new type of safety valve recently placed on the market by the Crane Company, Chicago. These valves are different from those heretofore made by this company, in that they have a greater lift and the casing is made of malleable iron. The main spring is also made of larger wire and the coil is of larger diameter. The lift has been increased on the open pop valve to 0.15 in., and on the muffler to 0.14 in., an increase of from .07 to .05 in. Excessive hammering of the valve as it closes from this relatively high lift is eliminated by the use of an auxiliary valve, also controlled by a spring, which covers a series of holes in the main valve, as shown in the drawing. As the main valve is lifted from its lower seat by the steam pressure, full opening is provided to it and the valve is lifted to its open position. As the pressure drops and the main valve lowers, steam will be caught in the

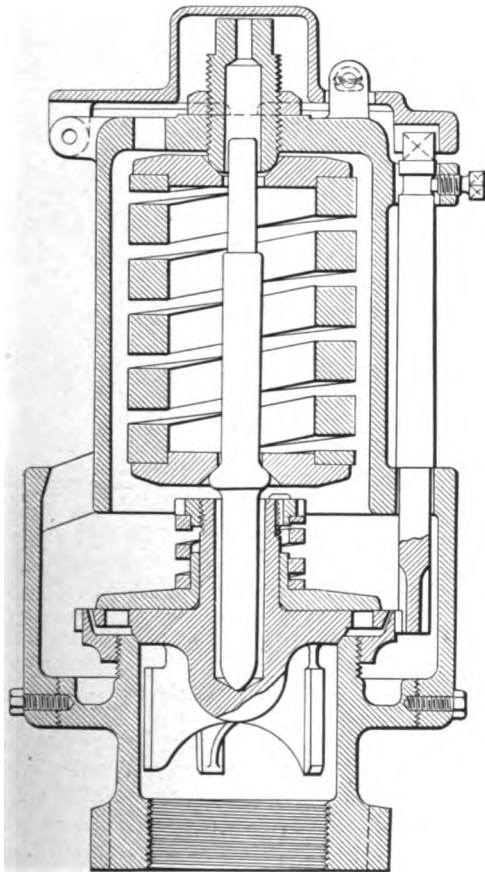

Improved Crane Safety Valve

cavities under the auxiliary valve, thus cushioning the main valve and preventing the severe shock that has many times been found very objectionable on high lift valves.

The muffled valve is similar in construction to the open valve,

Type	Size	Boiler pressure	Lift	Discharge of steam per hour
Open	2½ in.	180 lb.	.15 in.	7,500 lb.
Open	3 in.	180 lb.	.15 in.	9,200 lb.
Open	2½ in.	200 lb.	.15 in.	8,300 lb.
Open	3 in.	200 lb.	.15 in.	10,100 lb.
Muffler	2½ in.	180 lb.	.14 in.	6,500 lb.
Muffler	3 in.	180 lb.	.14 in.	8,600 lb.
Muffler	2½ in.	200 lb.	.14 in.	7,200 lb.
Muffler	3 in.	200 lb.	.14 in.	9,400 lb.

and instead of using two muffler plates, as was done in the old type, only one is used, it being made a part of the casing. By means of these high lift valves it has been found possible to use smaller valves as the capacity has been so materially increased. The accompanying table shows the discharge of steam per hour with 2½ and 3 in. valves of both types.

GENERAL UTILITY VISE FOR DRILL PRESSES

The vise shown in the illustrations was designed to replace a variety of jigs and special fixtures for holding various sizes and shapes of work on the table of the drill press. It has proved

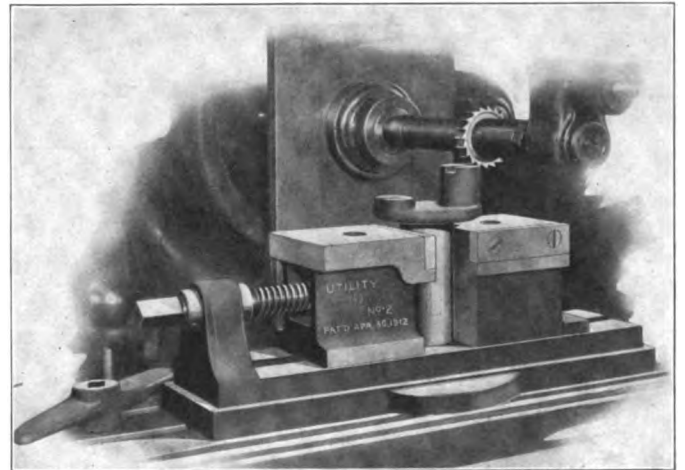

Work Secured In Vertical V-Groove of the Utility Vise

to be equally adapted to other machines on which the work is held stationary, such as milling machines and shapers.

The vise consists of a flanged bed plate so designed that it

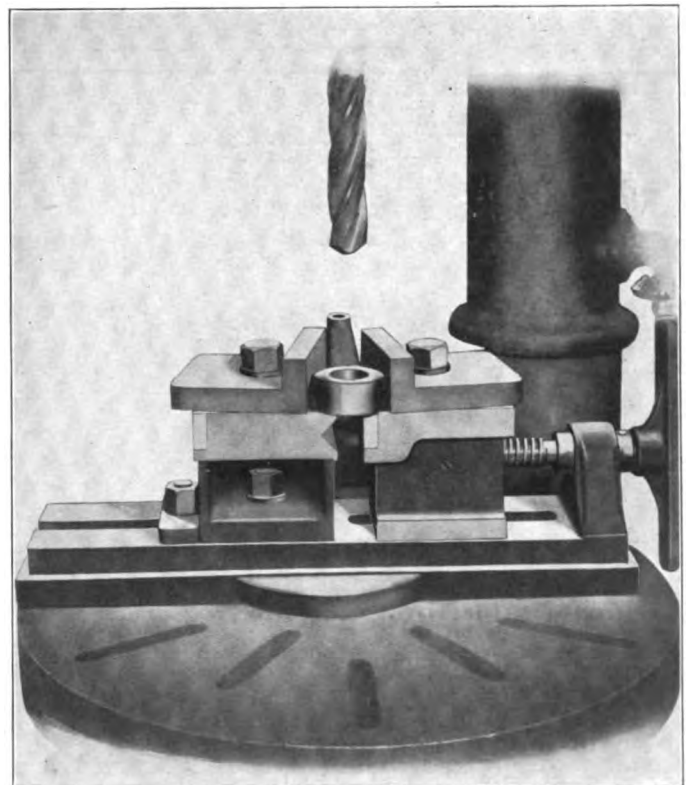

Supplementary Jaws for Holding Irregularly Shaped Piece

may be fastened to the machine table in any position, a screw operated front jaw, a stationary rear jaw and a variety of supplementary jaws which may be secured to the top of the main jaws for handling irregularly shaped pieces. The front jaw is held in position by a tongue passing through a slot in the bed and secured on the bottom with a plate and screws. The gripping surface is fitted with a removable steel plate. The rear jaw is made in the form of a hollow cube, one side being left open to admit a wrench for operating the nut on the binding bolt. The hole through which this bolt passes is drilled in the center of the jaw. It may thus be revolved on the bolt and fastened to the bed with any one of the three closed faces opposite the face of the front jaw. One of these faces is provided with a removable steel plate similar to that on the front jaw. Another is machined full depth for use as an angle plate, a vertical V-groove extending the full depth of this face to permit centering and holding rounds, squares and similar stock in a vertical position. The opposite side is provided with a horizontal V-groove for holding bar stock when drilling at a right angle to the axis of the bar.

One of the illustrations shows the adaptability of the device for holding irregularly shaped pieces by the addition of supplementary jaws to the top faces of the main jaws. These vises are manufactured by the Brown Engineering Company, Reading, Pa., and are provided with several types of supplementary jaws other than those shown.

SQUIRT HOSE EJECTOR

The accompanying engraving shows the general arrangement and details of an ejector designed to furnish moderately warm water under sufficient pressure for the safe operation of the locomotive cab squirt hose. It was recently developed by the Ohio Injector Company, Chicago, Ill., and consists of two parts: the ejector, which is connected to the injector suction pipe near the strainer, and a heater check connected to the injector branch pipe. The operation of the squirt hose is controlled by a one inch valve in the cab.

By referring to the sectional view of the heater check it will

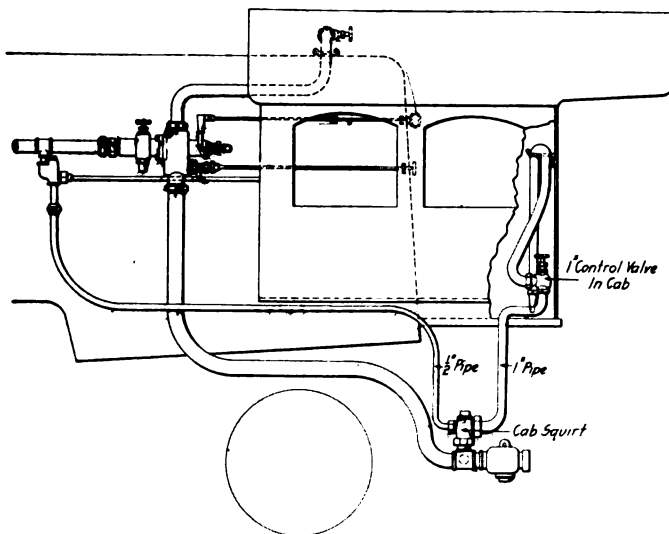

Arrangement of the Squirt Hose Ejector on the Locomotive

be seen that when the boiler feeding injector is working, water at a high temperature and pressure enters the heater check at the opening *A*, which is connected to the branch pipe, lifts the check valve and passes out through the opening *B* into a pipe leading to the cab squirt. To prevent freezing in cold weather when the injector is shut off a small amount of live steam enters the heater check body through a choke fitting and passes

through the opening *B* to the ejector. This steam is prevented from passing into the branch pipe by the heater check valve and an ordinary check valve placed at any convenient point in the live steam pipe prevents any tendency for water from the branch pipe to pass through the choke into the boiler when the injector is working.

The water at high temperature and pressure enters the ejector

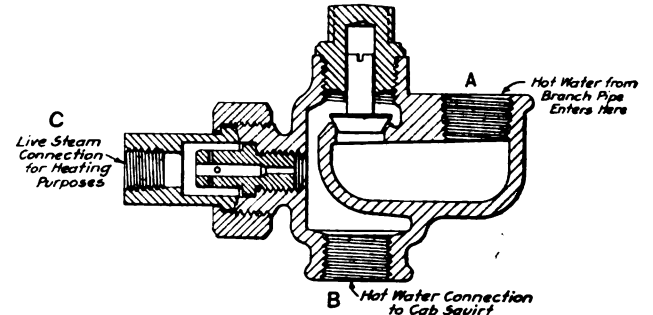

Sectional View of the Heater Check

through a one-half inch pipe, and whenever the control valve in the cab is opened it passes through the ejector combining tube, where it mingles with a large quantity of cold water drawn from the injector suction pipe through the check valve shown. The device is claimed to effect the delivery of a good stream of water at a moderate temperature and safe pressure.

In using this device the engineman is not required to make any movements other than those necessary with the usual form

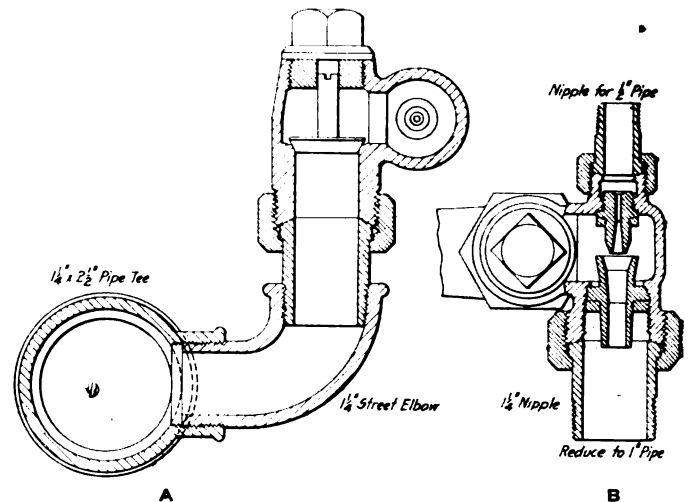

(A) Sectional Elevation and (B) Sectional Plan of the Ejector Proper

of cab squirt receiving its water supply directly from the injector branch pipe. All that is necessary is to have the injector working and to open the control valve. The device is applicable to locomotives fitted with injectors of either the lifting or non-lifting type.

BRITISH HOSPITAL TRAIN FOR THE CONTINENT.—At the Stratford works of the Great Eastern an ambulance train consisting of five ward cars, two kitchen cars, and one pharmacy car, has been built for service with the British troops in France, and presented by the United Kingdom Flour Millers' Association. The train is 428 ft. long. Each coach for the wounded will accommodate thirty men, thus giving room for 150 in all. The train is lighted by electricity, and the cookers in the two kitchen coaches are heated by anthracite fuel. At the top of the coaches are tanks of 300 gallons capacity for the water supply; the heating is by steam pipes, and each coach weighs between 27 and 28 tons.

UNDERFRAME SUSPENSION OF CAR LIGHTING GENERATORS

An electric car lighting equipment has recently been brought out in which the generator is suspended from the underframe of the car instead of from the truck. The equipment is manufactured by the Safety Car Heating & Lighting Co., 2 Rector street, New York, and a number of sets now in service are claimed to be giving entire satisfaction.

Several conditions have arisen in connection with the suspen-

so low that snow and ice cause trouble during the winter months. The underframe suspension was developed to overcome these and other difficulties arising from the older method of suspension.

The general appearance of the generator and its suspension and the method of attaching it to the underframe are shown in Fig. 1. The successful operation of this type of suspension depends upon the ability to maintain a uniform belt tension through the comparatively wide range of adjustment necessary to take care of the curving of the truck. The method of securing uniform belt tension will be understood by referring to Figs. 2 and 3. Cast on the generator frame are two carrying lugs *A*, which are pivoted to supporting lugs *B* on the suspension casting by a bar, the end of which is shown at *C*. The end of the tension spring shown at *H*, Fig. 4, is secured to a bracket *E* on the suspension casting, while the end shown, *G*, Fig. 4, engages with

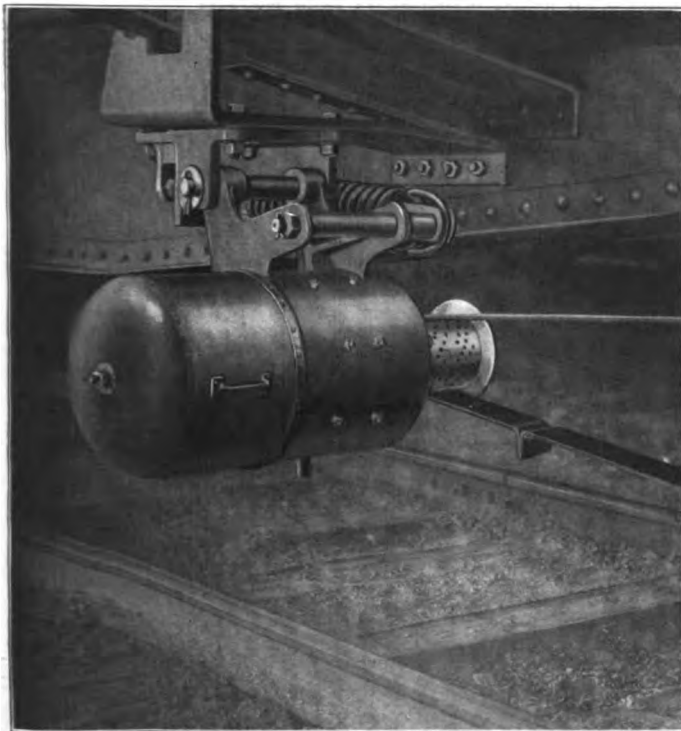

Fig. 1—Car Lighting Generator Suspended from the Underframe

sion of car lighting generators from truck frames which are increasing the difficulty of properly designing this type of equipment for application to steel trucks and steel car bodies of the type of construction now commonly employed. The deep center sill generally used on all-steel and steel underframe equipment has

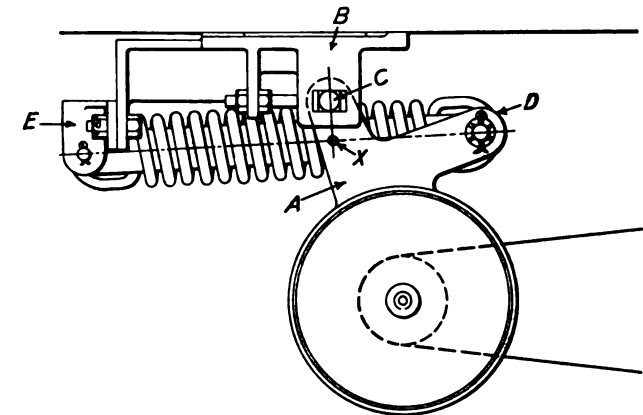

Fig. 3—Position of Generator when Effect of Weight is a Maximum

the lug *D* on the generator frame. The tension of the belt is the result of two varying factors, one of which is the horizontal component of the weight of the generator, and the other the tension of the spring. When the generator is hanging as shown in Fig. 2 so that its center of gravity is directly under the supporting bar *C*, the weight of the generator has no effect on the tension of the belt, but the tension of the spring has its greatest effect, since the lever arm, *CX*, is greatest. When the generator is swung into the position shown in Fig. 3, the effect of its weight is a maximum, while the effect of the spring is decreased due to the shortening of the distance *CX*. The parts are so designed that the combined effect of these two factors is practically constant in all positions. Ample latitude is provided between the two extreme positions shown to take care of belt stretch and

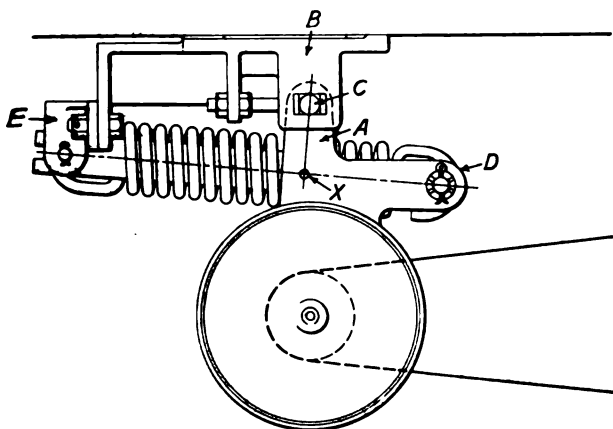

Fig. 2—Position of the Generator when Effect of Spring is a Maximum

limited the space available for applying the generator to such an extent that it is difficult to obtain the proper clearances for the generator and the driving belt. The suspension of the generator from the truck frame also produces an unbalanced condition in the loading of the equalizer coil springs, and the suspension is

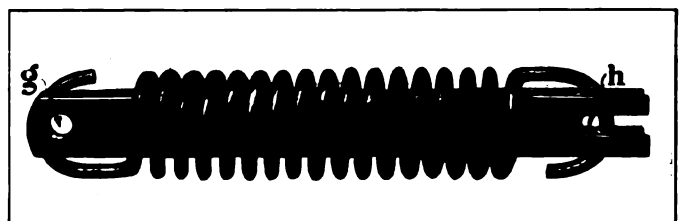

Fig. 4—Belt Tension Spring Assembled on Its Carrier

the varying location of the axle due to the curving of the truck. The spring is assembled on a carrier under tension so that it may be easily applied and removed.

A simple means of lining the generator with the car axle is provided. The hole for the supporting bar in the lug *B* is slotted, the position of the bar in the slot being readily adjusted and locked by means of the bolt and lock nuts shown in the engravings.

With the increased belt clearances obtained with this equip-

ment it has been possible to use a type of belt fastener which operates properly on small pulleys. A smaller armature pulley has therefore been used and a higher ratio between the axle pulley and the armature pulley obtained. The increase speed of the generator thus produced has made possible the design of a generator of lighter weight. This saving, together with the reduction in the weight of the suspension itself has resulted in a total reduction for this type of equipment of nearly 900 lb., and the truck has been entirely relieved of the unsprung and unbalanced weight usually suspended from one end of its frame.

The underframe suspension has made possible a considerable increase in the clearance between the generator and the track, and the moving parts of the suspension are still further removed from the track by being placed above the generator. The effect of snow and ice in severe weather conditions is therefore considerably reduced. The suspension of the generator from the car body also produces more favorable conditions with regard to wear since the moving parts, both of the generator and the suspension, receive the full benefit of the truck springs.

PISTON VALVES APPLIED TO SLIDE VALVE CYLINDERS

The application of superheaters to existing engines having slide valve cylinders has heretofore presented serious difficulties in view of the accepted fact that only piston valves can be used successfully with superheated steam. The cost of new piston valve cylinders with their accessories, together with the new front frame sections necessary to obtain a good design of cylinders; the changes necessary in the valve gear, etc., frequently entail so considerable an expenditure as to cause abandonment of the project.

The device here illustrated offers a solution of the problem by enabling a piston valve to be applied to the existing slide valve cylinders without any modification of the cylinders, valve gear

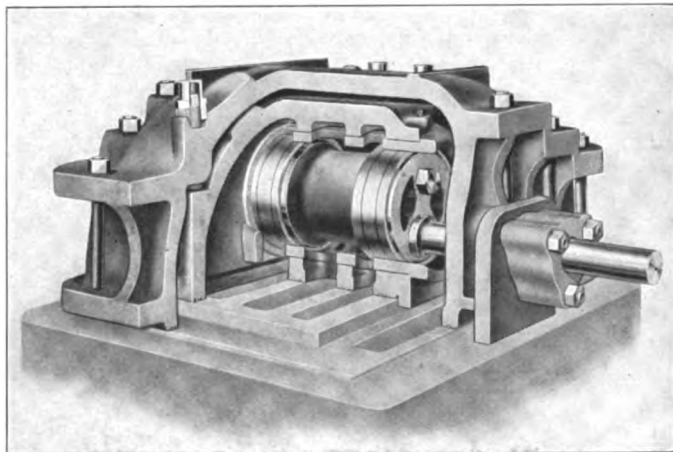

Construction and Method of Application of Universal Piston Valve

or other details. It consists of an inner valve chamber to which a continuous bushing is applied in the ordinary manner. Enclosing this is a steam chest secured to the cylinder by the usual studs without alteration in their original arrangement. The valve chamber is secured to the valve seat by four studs, and six holding-down screws tapped through bosses on the top of the steam chest, in addition to the steam pressure, which is exerted over practically 70 per cent of the area of the seat.

Joint wires of the usual form are used between the steam chest and its seat and wires of the same size are employed between the valve chamber and valve seat. These latter wires are arranged in an ingenious manner to avoid the use of double wires on the bridges, where it is difficult to apply sufficient direct pressure to bed them into the irregularities of the faces. In

this arrangement a joint wire surrounds each of the steam ports, and an outer wire surrounds the whole. Thus the double wires come only at the ends and sides of the valve seat where direct pressure can be applied.

A very short and light piston valve is used, with the center of its stem offset downward to conform to the location of the valve yoke stem of the original slide valve. The body of the valve is of oval section, thereby facilitating the passage of the exhaust steam downward to the exhaust port. The form of steam port in the valve chamber is such as to provide ample area for the ingress and egress of steam to the ports in the bushing, and eliminate all baffles which cause eddy currents.

The valve diameter is determined by the length of the ports in the valve seat, being such that its effective length (deducting bridges) is somewhat greater than the port length of the flat valve seat, which has been proved by actual test to be sufficient. This method gives valve sizes and weights as follows:

Port length	Valve diameter	Weight of valve
Up to and including 19 in.....	8 in.	58 lb.
20 in. to 22 in. inclusive.....	9 in.	65 lb.
23 in. and over.....	10 in.	73 lb.

By the use of these small, light piston valves, the wear and tear on the valve gear is reduced to a minimum. As the section of packing ring is the same as for the large valves commonly used, the result is a greatly diminished tendency to buckle and score the bushing while crossing over the ports when superheated steam is used, trouble from this source being practically eliminated. Diagonal bridges are employed in the valve bushing to obviate grooving of the rings.

A notable feature of this arrangement is that outside steam pipes may be used, thereby eliminating all live steam passages from the cylinder saddle, as has become the accepted practice with superheat. In this case a tight cover plate is bolted over the steam pipe boss in the smoke box, and the steam passages in the saddle filled with a rich concrete mixture. A short bent section of steam pipe is used immediately above the chest to facilitate its removal without disturbing the pipes in the smokebox.

This valve was developed by the Economy Devices Corporation, 30 Church street, New York.

HAND BRAKE FOR FREIGHT CARS

In an endeavor to secure a powerful hand brake for freight cars without sacrificing rapidity of action, the geared brake shown in the drawing has been developed by the National Brake Company, Buffalo, N. Y. This device, known as the Peacock freight car brake, consists of a malleable iron frame, a geared drum and shaft, and a pinion secured to the lower end of the brake shaft. The brake is operated by the usual type of shaft, the lower end of which is forged to a square section where it passes through the pinion, a cotter through the end securing it in position. Sufficient clearance is provided through the pinion so that finish is unnecessary and the space between the shaft and the gear readily frees itself from dirt which would tend to collect were a closer fit used.

The drum and gear are cast integral, holes being cored through the web of the gear to lighten it as much as possible and also to prevent the accumulation of dirt on its upper surface. The surface of the drum is formed into a shallow spiral groove, the bottom of which is over 2 in. in diameter. This eliminates the twisting and cutting of the chain, caused by the small drum usually employed. The upper portion of the drum is so designed that the center line of the chain follows a parabolic curve as the drum revolves, the end of the chain being secured at a point near the rim of the gear. This facilitates taking up the slack without loss of time or sacrifice of leverage when the effective application begins.

The chain is secured to the drum by a bolt in double shear which passes through a slotted hole. When in place the pull of the chain moves the bolt in the slot until its head occupies

a pocket on the upper surface of the web from which it cannot be directly removed. A cotter through a lug on the web of the gear prevents the head of the bolt from sliding out of the pocket should the pull on the chain be released. The drum revolves on a straight unfinished bar of cold rolled steel, the lower end of which rests in a pocket in the frame. The drum is bored out with ample clearance and is packed with graphite grease to prevent corrosion when the car is standing out of service. A cotter through the lower end of the bar and the frame prevents it from turning and cutting the frame. The brake has a gear ratio of 12 to 48, and with a force of

The foot of the jack is so designed that the auxiliary heel plate may be applied in two positions at right angles to each other, thus permitting the operation of the jack tilted either sideways or forward. The heel plate provides a substantial footing for the tool in any position without the necessity of special blocking.

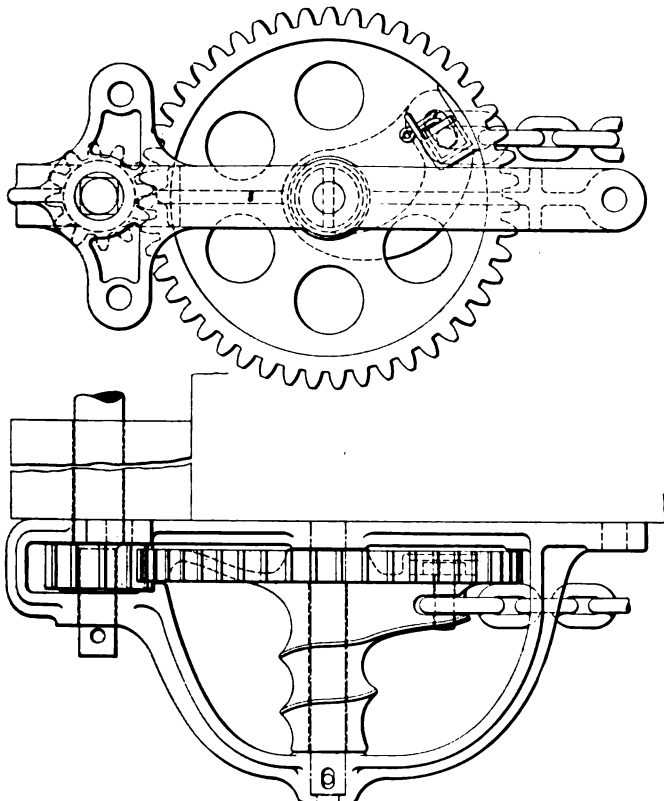

Geared Hand Brake for Freight Cars

100 lb. exerted at the rim of a 16 in. brake wheel it is claimed to produce over 1,700 lb. pull on the chain. This is more than four times the force exerted on the chain by the usual type of hand brake where the chain is wound on a 1½ in. drum at the lower end of the brake shaft.

To successfully meet the conditions imposed upon a hand brake for freight equipment cars the cost must be low. With this consideration in view the use of finished parts has been avoided as far as possible, the only finished surface in the device being the bore of the drum. As shown in the drawings, the frame is designed for application to cars having platform end sills, but the brake may be designed for application to freight cars of any type.

EMERGENCY JACKS

The jacks illustrated herewith include several interesting features which are especially valuable in equipment designed for emergency use. They have recently been added to the line of the Buckeye Jack Manufacturing Company, Alliance, Ohio.

The features of special interest are the swivel top, to which is pivoted an auxiliary hook for low lifting operations and an auxiliary heel plate which enables the operator to use the jack at an angle without blocking up. An adjustable auxiliary lift is shown on one of the jacks, which may be quickly adjusted to the load without sacrificing a portion of the lifting range of the jack.

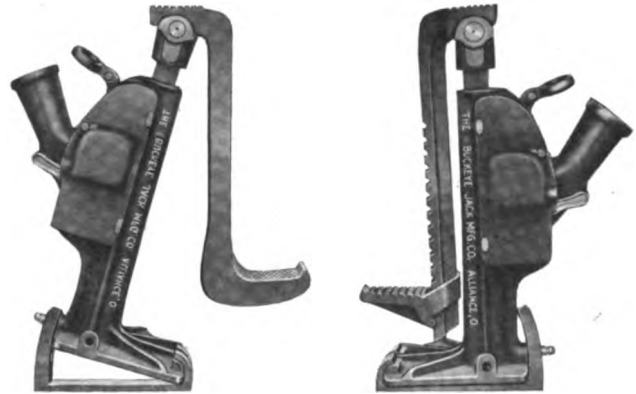

Jacks with Adjustable Heel Plates

When so desired it may be removed and the jack operated upon its own base.

In designing these tools special attention has been given to the elimination of unnecessary parts in order that the number of repair parts required may be kept at a minimum. The parts are easily assembled, and repairs may be made by the ordinary shop labor.

FRICTION SPRING DRAFT RIGGING

The Slick friction spring draft rigging, which is shown in the accompanying illustration, consists of a number of springs formed of comparatively thin steel plates. These plates are square or rectangular and are corrugated, the axes of the cor-

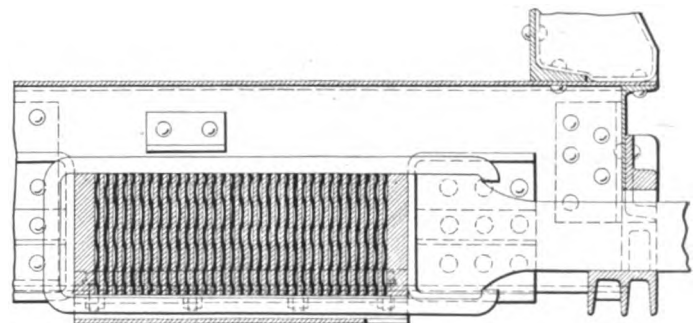
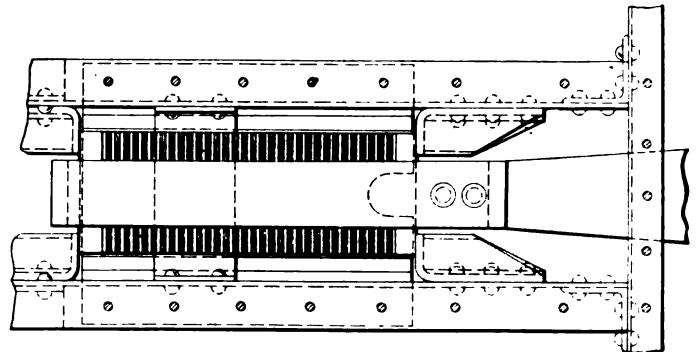

Slick Friction Draft Rigging

rugations being parallel to each other. The plates are placed so that the corrugations of each one are at right angles to those of the two adjoining ones. The arched portions of the plates are thus in contact with each other, and each plate forms an abut-

ment against which the adjoining plate operates. The device may be made either with single corrugated spring plates or where greater stiffness is desired the elements may be made up of two or more laminations each. The construction of the rigging is otherwise similar to that commonly used with other types of spring elements.

When under load the plates withstand stresses first by the spring action of the corrugated portions, which tend to flatten out under pressure, and in addition by the frictional resistance to the movement of the plates one upon another due to the flattening out of the corrugations. This action tends to dissipate a portion of the energy delivered to the draft rigging.

It is also claimed that the arch action of the corrugations tends to distribute the stress through the curved portion of each corrugation in such a way as to counteract to a certain extent the force in the tension side of the plates. The depth of the corrugations is such that when each plate is flattened under load the stresses will be about equal to the proper working stress for the material, thus insuring long life of the spring elements.

This draft rigging has been developed by the Cambria Steel Company, Philadelphia, Pa.

VACUUM OIL BURNER

The Gustin-Bacon Manufacturing Company, Kansas City, Mo., has recently placed on the market a new type of oil burner that is especially adapted for service in railway shops. The chief feature of this burner is that the oil is drawn from the supply tank by a partial vacuum created in the oil pipe by compressed air passing over a series of holes in the end of the pipe, forming practically an ejector. Its application

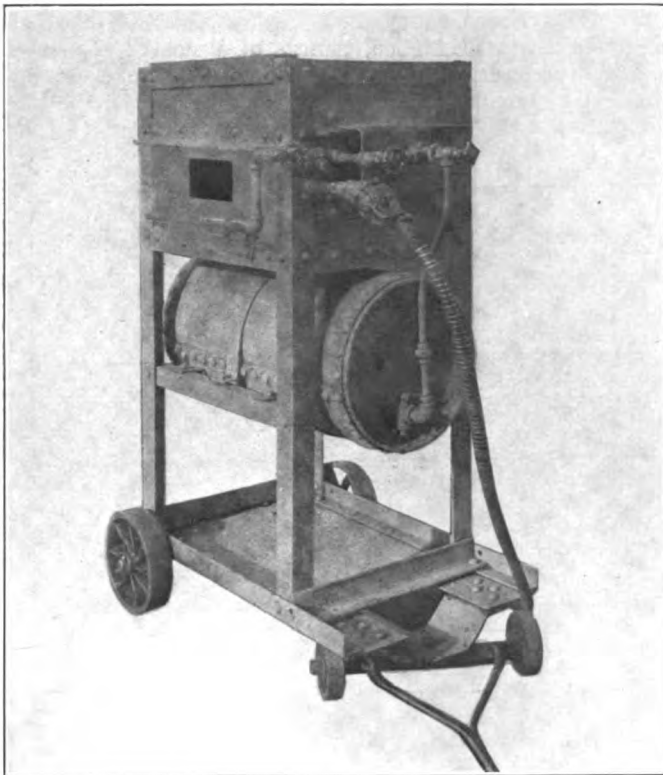

Portable Oil Heater Equipped with Vacuum Burner

to a portable oil heater is shown in the illustration. By the use of this device the carrying of oil under pressures which vary from 60 to 125 lb. is entirely eliminated, and with it the fire hazard occasioned thereby. That the device is a "safety first" measure is readily recognized. The suction created in the oil pipe is sufficient to supply more oil than is

generally required through the 3/8-in. pipe connecting the burner with the oil reservoir and the angle valve on the end of the burner is used to regulate the quantity of oil required to give the proper temperature. With this system the oil reservoir may be refilled while the furnace is being operated. The ordinary shop line air pressure is sufficient to operate the burner.

CLOTH-LINED METAL WEATHER STRIPS

The accompanying illustration shows a method of weather-stripping car windows that has recently been applied to passenger equipment. It is an adaptation of a method that has been in successful use in buildings for the past four years. It is designed with the idea of maintaining a perfect seal on all four sides of the window, and at the same time giving a free movement in raising and lowering. On the sides of the window a channel of No. 9 gage zinc, lined with three-ply Windsor cloth, is inserted into the window for about 17/32 in. The

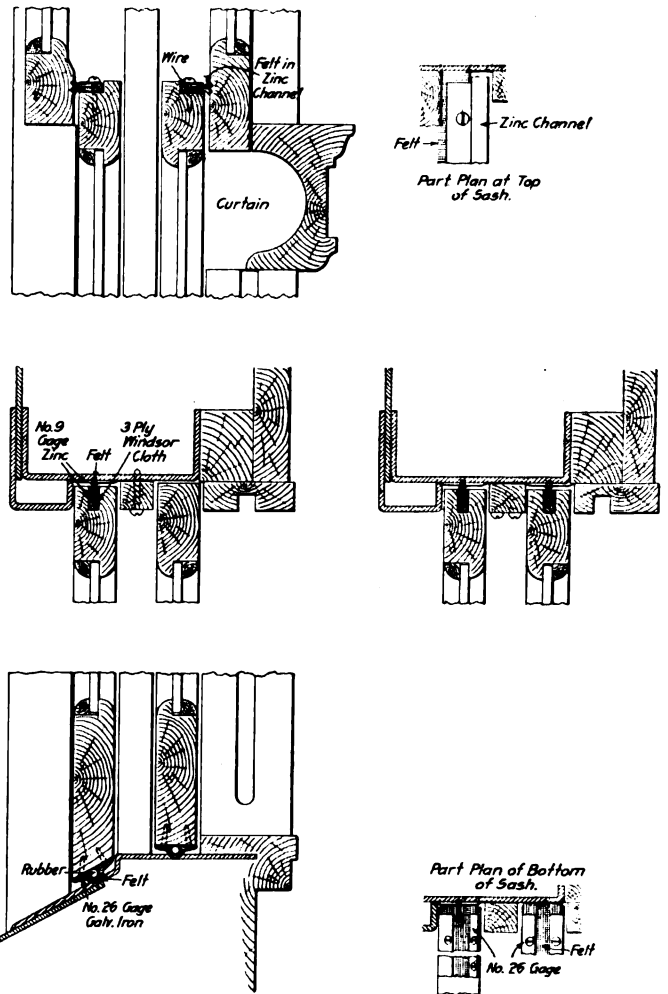

Metal Weather Strips with Cloth Lining

jamb-piece, which is also made of the same material, runs in this channel. The seal at the top consists of a similar channel with the felt inserted, as shown. This felt protrudes sufficiently to make a constant bearing when the window is closed. The bottom stripping is also clearly illustrated. A piece of No. 26 gage galvanized iron holds in place a strip of rubber surrounded by felt, which, when the window is closed, provides a seal at the sill. The greatest point of wear comes in the side weather-stripping, but the clearance between the jamb-piece and the channel is such that excessive wear of the cloth will not be possible. This weather-stripping is made and sold by the Athey Company, 1907 Michigan Boulevard, Chicago, Ill.

TIME STUDY WATCH

A watch designed especially for making time studies and for determining the output of machines is shown in the accompanying illustration. The dial of the watch is divided into tenths and hundredths of a minute, which are the units used in taking time studies of machine tool operations. It is also provided with figures showing the hourly production for each two-hundredths of a minute. For example, as shown in the illustration, if an operation is performed in 0.16 of a minute, it is being performed at the rate of 375 per hour.



Stop Watch for Time Study Work

The watch is also designed to start and stop without the hand going back to zero. This is of special advantage when it is found necessary to take time out during any individual operation. The small dial in the center of the watch registers the minutes. The watch is started by pushing the slide on the side towards the stem and it is stopped by pushing this slide in the reverse direction. The hands are brought back to zero by pressing on the crown. This watch is sold by Mortimer J. Silberberg, Peoples Gas building, Chicago, Ill., who has the exclusive sales rights.

INTERNAL GUIDE FOR PIPE THREADING TOOLS

An internal guide with a reamer point for use in pipe threading tools has recently been placed on the market by the Greenfield Tap & Die Corporation, Greenfield, Mass. The internal

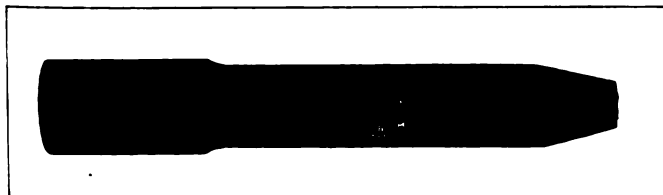

Internal Guide with Reamer Point for Use with Pipe Threading Tools

guide takes the place of the various forms of external or bushing guides which have been heretofore the only means of guiding the pipe stock to secure a straight thread. It not only effectively

guides the dies onto the pipe but, in addition, reams the burrs from the inside of the pipe as it enters, thus saving an extra operation.

As shown in one of the illustrations, the guide is constructed with a slightly enlarged end which fits closely into a bushing on the side of the stock farthest away from the die. It is held in place by a set screw and may be readily removed. This

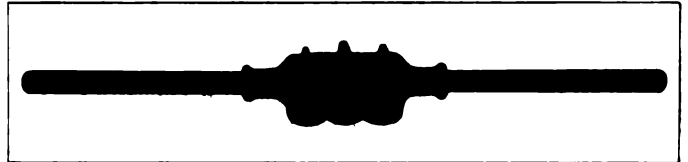

Pipe Stock Fitted with Internal Guides

guide is applied by the manufacturer to various types of pipe stocks, the one shown being fitted with three sizes of dies. One of the advantages of the use of the inside guide is that it permits threading on a much shorter projection than would be possible with a guide of the bushing type, which extends out in front of the die.

BRINE TANK DRAIN VALVE

The accompanying illustrations show two positions of a new type of brine tank drain valve for refrigerator cars invented by W. A. Bourell, 5439 Aberdeen street, Chicago. The valve body is riveted to the lower end of the tank and the gate is controlled, as indicated, by means of a handle at the top of the car just inside the hatch plug. The opening in the valve is provided with a rubber gasket and the gate is



Brine Tank Drain Valve In Closed and Open Positions

forced to a seat by the lugs shown on the valve casting. In order to open the valve the hatch plug must be removed and conversely the valve must be closed before the hatch plug can be replaced. This valve has been used on a number of cars in the West and has required very little maintenance expenditure. It is so constructed that trouble will not be experienced with freezing.

NEWS DEPARTMENT

The machine and blacksmith shops of the Seaboard Air Line at Portsmouth, Va., were destroyed by fire on the night of April 6.

The express car on Train No. 1 of the Louisville & Nashville was robbed on the line between Mobile and New Orleans, on the night of April 23, the safe in the express car being blown open. The baggageman was shot and dangerously wounded.

Of 336 fast freight trains run by the Baltimore & Ohio from New York, Philadelphia and Baltimore to Chicago, Columbus, Cleveland, Cincinnati and St. Louis, March 1 to 12 inclusive, only one suffered by delay, and this was the result of an unavoidable delay near Cincinnati.

The Lehigh Valley reports that 289 regular freight trains run during the month of March made a record of being on time 98.4 per cent. Eight daily through freight trains, leaving either Jersey City or Buffalo, arrived at their terminals every day on time. The New York State Public Service Commission, Second district, has advised the management that a recent ten-day check of I. c. I. freight between Buffalo and Geneva gave the Lehigh Valley 100 per cent for delivery on schedule time.

The carferry "Ontario No. 2," of the Grand Trunk, was successfully launched at the yards of the Polson Iron and Shipbuilding Company recently. The vessel was designed by William Newman, is of steel and cost \$500,000. It is to run between Coburg, Ont., and Charlotte, N. Y. It is 318 ft. long, 54 ft. beam and 20.5 ft. molded depth. She has capacity for 30 loaded 70-ton cars. Her speed will be 17 miles an hour. The vessel is built as an ice breaker and is expected to make her way through ice 4 ft. thick.

F. W. Brazier, superintendent of rolling stock of the New York Central Lines East of Buffalo, addressed the Railroad Men's Christian Association, New York, on April 14, on the subject "What Constitutes the Equipment Department of a Railroad." Figures were given showing the amount of equipment used on the railways of the United States, and an outline given of the mechanical department organization of the New York Central. The equipment department of this road has approximately 18,300 employees, with a payroll of about \$16,000,000 per year.

MEETINGS AND CONVENTIONS

American Railway Tool Foremen's Association.—At the annual convention of the American Railway Tool Foremen's Association which will be held at the Hotel Sherman, Chicago, July 19-21, 1915, the following topics will be discussed: Special Jigs and Devices in Locomotive Repair Shops; Safety First in Regard to Machinery and Tools; Special Tools and Equipment for Maintenance of Pneumatic Tools; Grinding and Distribution of Machine Tools in Locomotive Repair Shops, and Standardization of Reamers for Locomotive Repair Shops. This subject, which was taken up at the last convention, has been continued and each member of the association is requested to report on it at the coming convention. The selection of an emblem for the association will also be considered.

Meeting at Franklin Institute.—A paper on Locomotive Stokers was presented at the Franklin Institute, Philadelphia, April 21, by W. S. Bartholomew, president of the Locomotive Stoker Company, Schenectady, N. Y. Lantern slides were employed showing in detail the construction of the various types

of stokers now in service and a brief history of the development of mechanical stoking as applied to locomotives was given. There are now in successful service over 600 Street stokers, about 400 Crawford underfeed stokers and about 20 each of the Standard and the Hanna types. Mr. Bartholomew gave some figures showing the increase in tonnage effected by the use of mechanical stokers on large locomotives. The paper was discussed by representatives from the Baldwin Locomotive Works, the Chicago, Burlington & Quincy and the Baltimore & Ohio.

June Mechanical Conventions.—J. D. Conway, secretary-treasurer of the Railway Supply Manufacturers' Association, advises that already 178 exhibitors have arranged for space on Young's Million-Dollar Pier during the Master Mechanics' and Master Car Builders' conventions in June. Applications for space are coming in daily, and in spite of the business depression the indications are that the exhibits this year will be at least as extensive as, and possibly larger than, those of last year. The list of exhibitors shows a number of new companies which have never before exhibited. There seems to be little question but that the New Traymore Hotel will be open to receive guests by June 1. It will have 700 rooms with private baths and, it is said, will compare favorably with the newer and better class hotels of New York. The Convention Hall on the Million-Dollar Pier will be considerably enlarged and the exhibit space designated as Hotel Men's Annex will be enclosed with glass. Other improvements and rearrangements are being made in the space, which, it is expected, will add greatly to the effectiveness of the exhibit.

International Engineering Congress.—Volume IV of the transactions of the International Engineering Congress, which will be held at San Francisco in September, will comprise an important series of papers on the general subject of "Railways and Railway Engineering." This field will be treated under seven principal topics covering the relation of railways to social development; the present status of railways; the economic factors governing building of new lines; location; the physical characteristics of road including track and roadbed; bridges; tunnels; terminals; construction methods; signals; road equipment, including motive power other than electric; rolling stock in general; floating equipment; electric motive power in general. Approximately 27 papers are expected for this volume, prepared by authors representing 9 different countries. The list of authors includes many of the most eminent names in this field of engineering work throughout the world.

The volume will be well illustrated with charts, diagrams and half-tones, and will contain discussions contributed by leading American and foreign engineers.

The transactions of the congress as a whole will include nine or ten other volumes, covering the various fields of engineering work.

Traveling Engineers' Association.—The following is the program for the twenty-third annual convention of the Traveling Engineers' Association, to be held in the Hotel Sherman, Chicago, from September 7 to 10:

TUESDAY, SEPTEMBER 7

Morning session: Opening exercises and consideration of the subject: What effect does the mechanical placing of fuel in fireboxes and lubricating of locomotives have on cost of operation? W. L. Robinson (B. & O.), chairman.

Afternoon session: Recommended practices for the employment and training of new men for firemen; L. R. Pyle (M. St. P. & S. S. M.), chairman.

WEDNESDAY, SEPTEMBER 8

Morning session: The advantages of the use of superheaters, brick arches and other modern appliances on large engines, especially those of the Mallet type; J. E. Ingling (Eric), chairman.

Afternoon session: How can the road foreman of engines improve the handling of the air brakes on our modern trains? C. M. Kidd (N. & W.), chairman.

Evening: The entire evening will be devoted to examining the exhibits.

THURSDAY, SEPTEMBER 9

Morning session: Difficulties accompanying prevention of dense black smoke and its relation to cost of fuel and locomotive repairs; Martin Whelan (C. C. C. & St. L.), chairman.

Afternoon session: The electro-pneumatic brake; by W. V. Turner (Westinghouse Air Brake Company).

FRIDAY, SEPTEMBER 10

Morning session: The effect of properly designed valve gear on locomotive operating and fuel economy; W. E. Preston (Southern).

Afternoon session: Scientific train loading; tonnage rating; the best method to obtain maximum tonnage haul for the engine over the entire division, taking into consideration the grades at different points on the division; by O. S. Beyer, Jr. (Rock Island).

Election of officers and adjournment.

International Railway Fuel Association.—The following is the program of the seventh annual convention of the International Railway Fuel Association, to be held at Hotel La Salle, Chicago, May 17 to 20:

MONDAY, MAY 17

Morning session, 9:30 to 12:30.

Invocation; address by president; address by A. M. Schoyer, vice president, Pennsylvania Lines West; report of secretary-treasurer; appointment of committee to audit books of secretary-treasurer; appointment of special committees; unfinished business; new business.

Paper: Powdered Coal—Preparation and Use in Locomotive and Stationary Boilers; by W. L. Robinson, supervisor fuel consumption, Baltimore & Ohio.

Afternoon session, 1:30 to 4:30.

Paper: Fuel Conditions in South America; by J. W. Hardy, sales agent, West Kentucky Coal Company.

TUESDAY, MAY 18

Morning session, 9:30 to noon.

Paper: Analysis of Dependent Sequence as a Guide to Fuel Economy; by Harrington Emerson, consulting engineer.

Paper: Smoke Prevention; by E. W. Pratt, superintendent of motive power and machinery, Chicago & North Western.

Afternoon session, 1:30 to 4:30.

Paper: Standardization of Coal Preparation; by H. C. Adams, president, Jones & Adams Coal Company.

Report of committee on Fuel Stations, H. J. Slifer, consulting civil engineer, chairman.

WEDNESDAY, MAY 19

Morning session, 9:30 to noon.

Paper: Relation of Mechanical Stokers to the Fuel Problem; by committee on Firing Practice, D. C. Buell, director, the Railway Educational Bureau, chairman.

Paper: Fuel Oil for Locomotive Use; by G. M. Bean, Pacific Coast representative, American Arch Company.

Afternoon session, 1:30 to 4:30.

Paper: Waste of Fuel in Railway Stationary Plants; by Joseph W. Hays, combustion expert.

Report of committee on Storage of Coal.

THURSDAY, MAY 20

Morning session, 9:30 to 1:00.

Reports of Standing and Special committees on: Drafting Locomotives; Fuel Tests; Fuel Accounting; Constitution and By-Laws; Subjects for Eighth Annual Meeting; Election of Officers; Balloting for place of meeting, eighth annual convention; Adjournment.

The following list gives names of secretaries, dates of next or regular meetings, and places of meeting of mechanical associations.

AIR BRAKE ASSOCIATION.—F. M. Nellis, 53 State St., Boston, Mass. Convention, May 4-7, 1915, Hotel Sherman, Chicago.

AMERICAN RAILROAD MASTER TINNERS, COPPERSMITHS AND PIPEFITTERS' ASSOCIATION.—W. E. Jones, C. & N. W., 3814 Fulton street, Chicago. Annual meeting, July 13-16, 1915, Hotel Sherman, Chicago.

AMERICAN RAILWAY MASTER MECHANICS' ASSOCIATION.—J. W. Taylor, Karpen building, Chicago. Convention, June 9-11, 1915, Atlantic City, N. J.

AMERICAN RAILWAY TOOL FOREMEN'S ASSOCIATION.—Owen D. Kinsey, Illinois Central, Chicago. Convention, July 19-21, 1915, Hotel Sherman, Chicago.

AMERICAN SOCIETY FOR TESTING MATERIALS.—Prof. E. Marburg, University of Pennsylvania, Philadelphia, Pa. Convention, June 22-26, 1915, Hotel Traymore, Atlantic City, N. J.

AMERICAN SOCIETY OF MECHANICAL ENGINEERS.—Calvin W. Rice, 29 W. Thirty-ninth street, New York. Annual meeting, December 7-10, 1915, New York.

ASSOCIATION OF RAILWAY ELECTRICAL ENGINEERS.—Joseph A. Andreucetti, C. & N. W., Room 411, C. & N. W. Sta., Chicago. Annual meeting, October, 1915.

CAR FOREMEN'S ASSOCIATION OF CHICAGO.—Aaron Kline, 841 North Fifthieth Court, Chicago; 2d Monday in month, except July and August, Lytton building, Chicago.

CHIEF INTERCHANGE CAR INSPECTORS' AND CAR FOREMEN'S ASSOCIATION.—S. Skidmore, 946 Richmond street, Cincinnati, Ohio. Annual meeting, September 14-16, 1915, Richmond, Va.

INTERNATIONAL RAILWAY FUEL ASSOCIATION.—C. G. Hall, 922 McCormick building, Chicago. Convention, May 17-20, 1915, Chicago.

INTERNATIONAL RAILWAY GENERAL FOREMEN'S ASSOCIATION.—William Hall, 1126 W. Broadway, Winona, Minn. Convention, July 13-16, 1915, Hotel Sherman, Chicago.

INTERNATIONAL RAILROAD MASTER BLACKSMITHS' ASSOCIATION.—A. L. Woodworth, Lima, Ohio. Convention, August 17, 1915, Philadelphia, Pa.

MASTER BOILER MAKERS' ASSOCIATION.—Harry D. Vought, 95 Liberty street, New York. Convention, May 26-28, 1915, Chicago, Ill.

MASTER CAR BUILDERS' ASSOCIATION.—J. W. Taylor, Karpen building, Chicago. Convention, June 14-16, 1915, Atlantic City, N. J.

MASTER CAR AND LOCOMOTIVE PAINTERS' ASSOC. OF U. S. AND CANADA.—A. P. Dane, B. & M., Reading, Mass. Convention, September 14-17, 1915, Detroit, Mich.

NIAGARA FRONTIER CAR MEN'S ASSOCIATION.—E. Frankenberger, 623 Brisbane building, Buffalo, N. Y. Meetings monthly.

RAILWAY STOREKEEPERS' ASSOCIATION.—J. P. Murphy, Box C, Collinwood Ohio. Convention, May 17-19, 1915, Hotel Sherman, Chicago.

TRAVELING ENGINEERS' ASSOCIATION.—W. O. Thompson, N. Y. C. & H. R. East Buffalo, N. Y. Convention, September 7-10, 1915, Hotel Sherman, Chicago, Ill.

RAILROAD CLUB MEETINGS

Club	Next Meeting	Title of Paper	Author	Secretary	Address
Canadian	May 11	Annual Meeting, Election of Officers	James Powell	St. Lambert, Que.
Central	May 14	Locomotive of Recent Development	S. S. Riegel	Harry D. Vought	95 Liberty St., New York.
New England	May 11	Developments in Oxy-Acetylene Process	Henry Cave	Wm. Cade, Jr.	683 Atlantic Ave., Boston, Mass.
New York	May 21	Qualities of Good Steel Rails	Gustave Lindenthal	Harry D. Vought	95 Liberty St., New York.
Pittsburgh	May 28	J. B. Anderson	207 Penn. Station, Pittsburgh, Pa.
Richmond	May 10	Safety First	George Bradshaw	F. O. Robinson	C. & O. Ry., Richmond, Va.
St. Louis	May 14	Stereopticon Lecture; Special Addresses	J. W. Booth	B. W. Frauenthal	Union Station, St. Louis, Mo.
South'n & S'w'rn.	May 20	Mikado Type Locomotives	Mr. Kline	A. J. Merrill	Box 1205, Atlanta, Ga.
Western	May 18	Annual Meeting	Jos. W. Taylor	1112 Karpen Bldg., Chicago, Ill.
Western Canada	May 10	Annual Meeting	Louis Kon	Box 1707, Winnipeg, Man.

PERSONALS

It is our desire to make these columns cover as completely as possible all the changes that take place in the mechanical departments of the railways of this country, and we shall greatly appreciate any assistance that our readers may give us in helping to bring this about.

GENERAL

SHERIDAN BISBEE has been appointed fuel supervisor of the Boston & Albany, at Boston, Mass.

H. A. MACBETH, division master mechanic of the New York, Chicago & St. Louis at Conneaut, Ohio, has been appointed superintendent of motive power, with headquarters at Cleveland, succeeding E. A. Miller, deceased.

D. T. MAIN has been appointed superintendent of motive power of the eastern lines of the Canadian Pacific at Montreal, Que., succeeding W. E. Woodhouse, promoted.

H. H. VAUGHAN, assistant to vice-president of the Canadian Pacific, at Montreal, Que., at his own request, has been released from the immediate supervision of the construction and maintenance of locomotives and cars, in order that he may devote his attention to important contract engagements in which he has become interested. He is being retained as consulting engineer.

W. E. WOODHOUSE, superintendent of motive power of the Eastern Lines of the Canadian Pacific at Montreal, Que., has been appointed chief mechanical engineer.

MASTER MECHANICS AND ROAD FOREMEN OF ENGINES

T. C. BALDWIN has been appointed master mechanic of the New York, Chicago & St. Louis, with headquarters at Conneaut, Ohio, to succeed H. A. Macbeth, promoted.

A. H. POWELL, master mechanic of the Western Pacific at Sacramento, Cal., has been appointed general master mechanic, with headquarters at that place.

CAR DEPARTMENT

J. HODGSON has been appointed car foreman of the Canadian Northern at Montreal, Que.

CHARLES W. VAN BUREN has been appointed general master car builder of the Canadian Pacific, with headquarters at Montreal, Que., succeeding R. W. Burnett, resigned. Mr. Van Buren was born on October 18, 1867, in Rensselaer county, N. Y., attending the common schools until he was 16 years old, and for a year attended night school in New York City. He began railway work in 1889, on the New York Central & Hudson River. He was a carpenter at the West Albany shops until 1891, when he was made foreman, and two years later he was put in charge of car department work on the Adirondack division at Herkimer, N. Y. In 1896 he was transferred to Utica in charge of car department work on the Adirondack and the Mohawk divisions of the New York Central & Hudson River and the West Shore. He entered the service of the Canadian Pacific in July, 1905, as general car inspector on the lines east of Port Arthur. The following year he was appointed division car foreman of the Eastern division, remaining in that position until July, 1909, and then served as master car builder of the eastern lines of the same road, with headquarters at Montreal, until May, 1911. He then went to the Union Stock Yard & Transit Company, Chicago, as assistant general superintendent, remaining with that company until January, 1915, when he was appointed general foreman of the Milwaukee Refrigerator Transit & Car Company, at Milwaukee, Wis., which position he held until his recent appointment as general master car builder of the Canadian Pacific, as above noted.

SHOP AND ENGINE HOUSE

J. M. KERWIN has been appointed general foreman, locomotive department, of the Rock Island Lines, at Cedar Rapids, Iowa, succeeding M. B. McPartland, transferred.

M. F. McCARRA has been appointed roundhouse foreman of the St. Louis Southwestern at Illmo, Mo., succeeding P. H. Dwyer, resigned.

H. OSBORNE has been appointed works manager of the Angus shops of the Canadian Pacific at Montreal, Que. The Angus shops district, which has hitherto been operated as a separate unit, will hereafter be part of the Eastern Lines.

PURCHASING AND STOREKEEPING

G. W. GEHAN has been appointed storekeeper of the Canadian Pacific at Hochelaga, Que.

G. H. JOBIN has been appointed storekeeper of the Canadian Pacific at Place Viger, Montreal.

F. D. REED, assistant to the vice-president and purchasing agent of the Chicago, Rock Island & Pacific, has been appointed general purchasing agent, with headquarters at Chicago.



F. D. Reed

Mr. Reed was born April 22, 1868, at Fort Dodge, Iowa, and was educated in the public schools of Chicago. He entered railway service September 24, 1884, as wheel inspector of the car department for the Pennsylvania Lines West of Pittsburgh, at Chicago, which position he held until March, 1885, when he became clerk and timekeeper. In September, 1890, he was made chief clerk of the car department and held that position until July, 1895, when he was appointed assistant chief motive power clerk at Fort Wayne, Ind. In

February, 1900, he was appointed chief motive power clerk and remained in that capacity until April, 1904. He then entered the service of the Chicago, Rock Island & Pacific as chief motive power clerk at Chicago. In February, 1906, he was made general storekeeper at Silvis, Ill., and held that position until May, 1910, when he was appointed assistant to the vice-president. On June 1, 1911, he was appointed purchasing agent.

EDWARD J. ROTH has been appointed purchasing agent of the Chicago, Indianapolis & Louisville, with headquarters at Chicago. Mr. Roth was born on March 4, 1882, at Rochester, Minn. He began railway work with the Chicago, Burlington & Quincy, in 1902, and was employed in the store department of that road until April, 1914, at that time holding the office of assistant general storekeeper. He then went to the Chicago, Indianapolis & Louisville, as supply agent, which position he held until his recent promotion to purchasing agent, as noted above.

E. J. URTEL has been appointed purchasing agent of the Buffalo & Susquehanna, with headquarters at Buffalo, N. Y.

OBITUARY

James McGee, master mechanic of the Lorain, Ashland & Southern, with headquarters at Ashland, Ohio, died at his home in Lorain on April 6, aged 56 years.

SUPPLY TRADE NOTES

Wilber H. Traver, manager of the mining department of the Chicago Pneumatic Tool Company, died in Houghton, Mich., on April 15.

The Dearborn Chemical Company, Chicago, has opened an office in Edificio del Banco Anglo Súd-Americano, Buenos Aires, Argentine, in charge of Edward C. Brown.

The B. W. Parsons Co., dealing in railway material and mill supplies, has moved its offices in St. Paul, Minn., from the Pioneer building to 1306 Merchants Bank building.

A. Munch, who has been factory manager of the Maywood (Ill.) plant of the Hewitt Company, Chicago, has been appointed to the new position of service engineer for the same company.

The Chicago Pneumatic Tool Company, Chicago, has moved its New York office from 50 Church street to 52 Vanderbilt avenue, and its Boston office from 191 High street to 185 Pleasant street.

J. S. Wright, formerly in the Detroit office of Manning, Maxwell & Moore, Inc., has been appointed manager of the Boston office, succeeding Walter M. Wood, who has resigned because of ill health.

L. L. Cohen, formerly with the H. W. Johns-Manville Company, has resigned to accept service with the Safety First Manufacturing Company, with headquarters in the Railway Exchange, Chicago.

A. J. Poole, formerly superintendent of motive power of the Seaboard Air Line, has become associated with the Galena Signal Oil Company in the capacity of railway expert, with headquarters in Atlanta, Ga., effective April 15.

M. A. Sherritt, manager of the Philadelphia branch of Manning, Maxwell & Moore, Inc., New York, has resigned to accept the position of vice-president and general manager of the Sherritt & Stoer Company, Inc., Philadelphia, Pa.

W. B. Carnes, formerly in charge of the New York office of the Lima Locomotive Corporation, has been appointed western representative, with offices in the McCormick building, Chicago. He has been succeeded in the New York office by William T. Middleton.

The C. W. Hunt Company, Inc., manufacturers of coal handling and conveying machinery and small motor trucks, has moved its New York office from 45 Broadway to the eleventh floor of the new building of the Adams Express Company, 61 Broadway.

The Chicago office of the Westinghouse Electric & Manufacturing Company has taken over the sale of Nuttall gears, pinions and trolleys, manufactured by the R. D. Nuttall Company, Pittsburgh, Pa., for the electric railway, mining and industrial fields in the Chicago territory.

William Disston, president of Henry Disston & Sons, Philadelphia, Pa., died suddenly of heart disease at his summer home near Philadelphia on April 5. Mr. Disston was born in Philadelphia on June 24, 1859. Besides being president of the saw company he was head of the Henry Disston & Sons File Company, and the Henry Disston & Sons Steel Works.

W. B. Huey, until recently president of the American Blue Print Paper Company, and A. H. Huey, until recently sales manager of that company, announce the formation of a new company, under the name of the Huey Company, with offices and plant at 59 East Adams street, Chicago. The company will engage in the production of blue, black line and other prints, litho productions, hectograph copies and photostat reproductions.

J. P. Rapp, a steel wheel specialist, has resigned from the Forged Steel Wheel Company, Pittsburgh, Pa., and allied com-

panies, and has been appointed vice-president of the Gulick-Henderson Company, inspecting, consulting and chemical engineers, of New York. Mr. Rapp assisted Charles T. Schoen in developing his wheel, and has been directly connected with the industry from its earliest inception. He will give this item of railway equipment his particular attention.

The receivers of the United States Light & Heating Company, Niagara Falls, N. Y., announced to Judge Hazel of the United States District Court of the Western District of New York in Buffalo on March 30 that a complete reorganization of the company was now assured through the efforts of the stockholders protective committee which represents a controlling share of the preferred and common stock.

The Locomotive Pulverized Fuel Company has recently been organized, with offices at 30 Church street, New York, for the purpose of introducing the use of powdered coal, lignite and peat on steam locomotives. The officers are Joel S. Coffin, chairman; J. E. Muhlfeld, president; H. F. Ball, vice-president, and Samuel G. Allen, secretary and treasurer. This company has obtained the control of various practical appliances and processes which are essential to the effective and economical use of powdered anthracite and bituminous coal, lignite and peat in locomotive and other types of steam boilers used for railroad purposes, the equipment being also readily convertible, with practically no extra cost, for the use of fuel oil.

Joel S. Coffin, the chairman of the company, is also president of the Franklin Railway Supply Company, New York, which he organized in 1902, and vice-president of the American Brake Shoe & Foundry Company, Mahwah, N. J. He entered railway service when he was 17 years old as a shop apprentice and was later fireman, engineman, and road foreman of engines. In 1892 he entered the mechanical department of the Galena Signal Oil Company, becoming in 1896 manager of that department and in 1907 vice-president of the company.

John E. Muhlfeld, the president of the company, has been engaged for some years in railway expert work and has developed several important devices. He was born at Peru, Ind., on Sep-



J. E. Muhlfeld

tember 18, 1872. From 1889 to 1893 he attended classes in mechanical engineering at Purdue University, spending summer vacations in civil engineering work on the Peru & Detroit and as engine wiper and machinist apprentice in the Fort Wayne shops of the Wabash. After leaving Purdue he continued as apprentice, machinist and pit foreman until the summer of 1894 when the great railway strike of that year gave him an opportunity to become a fireman and engineman on the Wabash. As a result of the experience gained he was made, in

November, 1894, engine house foreman at Peru. He later became general foreman and remained with the Wabash until February, 1899, when he left to become master mechanic on the Grand Trunk. In September, 1901, he became superintendent of machinery and rolling stock on the Canadian Government Railways at Moncton, N. B., leaving in October, 1902, to become assistant to the general superintendent of motive power of the Baltimore & Ohio at Baltimore. In February, 1903, he was made

superintendent of motive power at Newark, Ohio, and in June, 1903, general superintendent of motive power at Baltimore. He held this position until November, 1908, when he left to engage in railway expert work. In this connection he made inspections and reports of the characteristics of a number of roads, including the Kansas City Southern, of which, from November, 1910, to August, 1912, he was vice-president and general manager.

H. F. Ball, vice-president, is also president of the Economy Devices Corporation, New York. He entered railway service in 1884 as an apprentice on the Pennsylvania at Altoona. In 1888 he entered the drafting room at Altoona, and in 1890 was appointed chief draftsman of the car department of the Lake Shore. In 1892 he was made general foreman of the car shops at Cleveland, and two years later became general car inspector. In 1899 he was made mechanical engineer and in 1902 superintendent of motive power. In 1906 he left the road to become vice-president of the American Locomotive Automobile Company, but a few months later his jurisdiction was extended over the American Locomotive Company as vice-president in charge of engineering. In December, 1912, he left the American Locomotive Company to open an office as special consulting engineer, becoming early in 1913 president of the Economy Devices Corporation. Mr. Ball was president of the Central Railway Club in 1900 and of the Master Mechanics' Association in 1905-6.

S. G. Allen, the secretary and treasurer of the new company, graduated from college in 1891 as a lawyer. After practicing for about nine years he became general manager of the Franklin Air Compressor Company, now part of the Chicago Pneumatic Tool Company. He is now vice-president of the Franklin Railway Supply Company, secretary of the American Arch Company, treasurer of the Locomotive Superheater Company, vice-president of the Economy Devices Corporation, secretary of the American Materials Company and vice-president of the General Equipment Company, all of New York, and secretary of the executive and finance committees of the American Brake Shoe & Foundry Company, Mahwah, N. J.

At the annual meeting of the stockholders of the Joseph Dixon Crucible Company, held in Jersey City, on April 19, the former board of directors was re-elected for the ensuing year. The vote recorded was the largest ever represented at an annual election—19,519 shares out of a possible 20,000. The directors re-elected the following officers: George T. Smith, president; George E. Long, vice-president; J. H. Schermerhorn, treasurer; Harry Dailey, secretary, and Albert Norris, assistant secretary and assistant treasurer.

The Linde Air Products Company, New York, has purchased a factory site in St. Louis on Forest Park Boulevard, between Sarah street and Boyle avenue; and the work of erecting buildings will be started as soon as plans can be drawn and contracts awarded. The St. Louis plant will be the fourteenth erected by the company, and with its completion Linde oxygen will be distributed from 39 points. In addition to oxygen the Linde Air Products Company also produces nitrogen and other rarer gases contained in the atmosphere.

Merrill G. Baker has been appointed assistant general manager of sales of the American Vanadium Company. Mr. Baker was formerly assistant to the general manager of sales of the Cambria Steel Company. He was born in Indiana county, Pa., in 1880, from which his parents moved to Johnstown, Pa., in 1884. He worked his way through preparatory school, paying his expenses by doing night work as a telephone operator, and later attended Dickinson college, from which he graduated with the class of 1904. He entered the employ of the Cambria Steel Company on January 3, 1905. He worked in various of that company's operating departments until July, 1906, when he entered the sales department. In September, 1912, he was appointed assistant to the general manager of sales in charge of the rail and structural departments.

CATALOGS

WATER SOFTENERS.—"The Kennicott Company" is the subject of a 29-page booklet prepared by Elbert Hubbard. The booklet is written in a breezy style and will be found of considerable interest.

TANK CALIBRATION CURVES.—The Universal Iron & Supply Co., St. Louis Mo., manufacturers of tanks, have issued a leaflet containing a calibration curve for horizontal, cylindrical tanks of any dimension. A copy of this curve will be sent to anyone on application.

DOOR HANGERS.—Catalog No. 12 recently received from the Richards-Wilcox Manufacturing Co., Aurora, Ill., illustrates in detail the line of door hangers, grindstones and hardware specialties produced by this company. The book is thoroughly illustrated and contains 296 pages, including an index.

ARC WELDERS.—The subject of Bulletin 1915-A from the Welding Materials Company, Inc., 114 Liberty street, New York, is Variable Voltage Welders. The subject of electric arch welding is dealt with at some length and a number of illustrations are given showing its application to locomotive and car work.

INSULATING BRICK.—"Good Furnaces Made Better" is the subject of a booklet issued by the Armstrong Cork Co., Pittsburgh, Pa., dealing with the Nonpareil insulating brick for furnaces and ovens. Illustrations and descriptive matter are included concerning the application of this type of brick to various furnaces.

NUT TAPPING MACHINES.—Tapper Talks, Nos. 1 and 2, have recently been issued by the National Machinery Company, Tiffin, Ohio, and deal with the National automatic nut tappers which operate on the bent tap principle. Illustrations of the machine at work are included and data given as to the advantages claimed.

VALVES.—The 1915 catalog, No. 18, from the Golden-Anderson Valve Specialty Co., Pittsburgh, Pa., contains 140 pages giving in considerable detail descriptive and illustrating matter concerning the various valves manufactured by this company. The valves include a large variety of types for both steam and water service.

POWER PLANT OIL FILTERS.—Bulletin No. 10 issued by the Richardson-Phenix Co., Milwaukee, Wis., is devoted to the Peterson power plant oil filter and accessory apparatus for central oiling systems. A large number of half-tone and line engravings are included and considerable information is given concerning oil filtration.

ARCH TUBE CLEANERS.—The Lagonda Manufacturing Co., Springfield, Ohio, has just issued a 12-page catalog entitled Lagonda Locomotive Arch Tube Cleaners. This catalog deals with the subject of scale removal from arch tubes in locomotive fireboxes and describes cleaners designed specially for this purpose. Copies will be sent on request.

HYDRAULIC PUMPS AND VALVES.—This is the subject of a mailing folder issued by the Hydraulic Press Manufacturing Co., Mount Gilead, Ohio. This folder contains illustrations and detail dimensions of the various hydraulic equipment manufactured by this company. The folder is designated as bulletin No. 5000 and will be sent free on request.

COOLING CONDENSING WATER.—The Spray Engineering Co., Boston, Mass., has issued bulletin No. 101 dated March 1, 1915, illustrating and describing the Spray cooling pond system of cooling condensing water. A number of good illustrations are included showing various plants equipped with this system and data is given concerning them. Bulletin No. 151 of the same company is entitled Washing and Cooling Air for Steam Turbine Generators and contains eight pages dealing with this subject.

Railway Age Gazette

MECHANICAL EDITION
INCLUDING THE
AMERICAN ENGINEER

PUBLISHED ON THE FIRST THURSDAY OF EVERY MONTH BY THE
SIMMONS-BOARDMAN PUBLISHING COMPANY,
WOOLWORTH BUILDING, NEW YORK, N. Y.

CHICAGO: Transportation Bldg. CLEVELAND: Citizens' Bldg.
LONDON: Queen Anne's Chambers, Westminster.

EDWARD A. SIMMONS, *President* L. B. SHERMAN, *Vice-President*
HENRY LEE, *Secretary*
The address of the company is the address of the officers.

ROY V. WRIGHT, *Editor*
R. E. THAYER, *Associate Editor* A. C. LOUDON, *Associate Editor*
C. B. PECK, *Associate Editor*

Subscriptions, including the eight daily editions of the *Railway Age Gazette* published in June in connection with the annual conventions of the Master Car Builders' and American Railway Master Mechanics' Associations, payable in advance and postage free:

United States, Canada and Mexico..... \$2.00 a year
Foreign Countries (excepting daily editions).... 3.00 a year
Single Copy 20 cents

Entered at the Post Office at New York, N. Y., as mail matter of the second class.

WE GUARANTEE that of this issue 6,600 copies were printed; that of these 6,600 copies 5,235 were mailed to regular paid subscribers, 250 were provided for counter and news companies' sales, 222 were mailed to advertisers, exchanges and correspondents, and 893 were provided for new subscriptions, samples, copies lost in the mail and office use; that the total copies printed this year to date were 32,500, an average of 5,417 copies a month.

The RAILWAY AGE GAZETTE, MECHANICAL EDITION and all other Simmons-Boardman publications are members of the Audit Bureau of Circulations.

VOLUME 89 JUNE, 1915 NUMBER 6

CONTENTS

EDITORIALS:	
Prevention of Damage to Lading.....	267
High Water and Superheaters.....	267
Sweeping Changes in Officers.....	267
Railway Fuel Convention.....	268
The Special Apprentice.....	268
The Art of Braking Trains.....	269
New Books.....	269
Communications.....	270
GENERAL:	
Fuel Association Convention.....	271
Mechanical Side of Railroading.....	283
Inspection of Locomotives and Tenders.....	284
Railway Storekeepers' Convention.....	285
Length of Radius Bar for Two-Wheel Trucks.....	290
Examples of Recent Locomotives.....	292
CAR DEPARTMENT:	
The Shipper, the Railway and the Car Man.....	293
Air Brake Association Convention.....	295
Steel Passenger Train Equipment.....	299
Dining Car Chairs.....	300
Steel Frame Double Truck Caboose.....	301
Proposed Gantry Crane for Car Repair Yards.....	304
SHOP PRACTICE:	
Great Northern Reclamation Plant.....	305
Locomotive Boiler Inspection.....	308
Double Tire Flanging Tool.....	308
Master Boiler Makers' Convention.....	309
Reclaiming Material.....	317
NEW DEVICES:	
Vertical Slabbing Machine.....	319
Motor Driven Power Hammer.....	319
Safety Brake Shoe.....	320
A Positive Nut Lock.....	320
Combination Oxy-Acetylene Welding and Cutting Torch.....	320
Center Drive Car Wheel Lathe.....	321
Air Pump Gland Nut Lock.....	322
Hard Grease Press.....	322
NEWS DEPARTMENT:	
Notes.....	323
Meetings and Conventions.....	323
Personals.....	324
New Shops.....	325
Supply Trade Notes.....	326
Catalogs.....	328

Prevention of Damage to Lading

Even with the great improvements made during the past few years, there is still much to be desired in some of the box cars which are in regular service, as regards the damage to and theft of lading. To a considerable extent this problem centers on proper doors and fastenings. There are still in service many cars with bottom door guides which are totally inadequate so far as gaining entrance to the car without breaking the seal is concerned. Weather strips are in many cases entirely useless when it comes to preventing the entrance of rain and cinders driven against the car. Many of the cars which have been for years in service have been brought up-to-date in these respects, but there are still many which are defective and moreover there are cars now being placed in service for the first time that are poorly constructed. There are still far too many new cars which seem to be neither designed nor built but merely put together and this fact is generally traceable to the officer who has the last word in the matter of expenditures. It seems impossible to convince some of these gentlemen that while a car is a car, it is not necessarily a good car, and as long as such officers prefer to save money in first cost and as a result spend more money in maintenance expenses and the settlement of loss and damage claims, badly designed and poorly built freight equipment will continue to be added to the country's rolling stock.

High Water and Superheaters

In the discussion on methods of treating locomotive boiler water at the recent convention of the Master Boilermakers' Association, it was stated that with treated water, in the case of superheater locomotives, considerable foaming can apparently occur and the water that is carried over to the superheater elements will be dried out and delivered to the cylinders in the form of steam. In bad water districts this is, at times, unavoidable, but it would seem that there are still some railroad men who do not realize the effect of such conditions on the operation of a superheater locomotive. The campaign of education which has been carried on throughout the country to prevent enginemen carrying the water too high on superheater locomotives has been eminently successful, but in view of the foregoing it might not be amiss to again call attention to the bad effects which result from using a superheater as a steam dryer. Setting aside the question of possible damage to the superheater, the device loses a part of its heating surface under such conditions in order to help the boiler in evaporating the water. This is a purpose for which the superheater was not intended and for which it should not be used. Its heating surface, when compared with that of the boiler to which it is applied, is so small that comparatively little water passing over will appropriate so much of the heat that should go to superheat the steam, that the device, as a superheater, may very easily be made useless. A high degree of superheat is absolutely necessary to efficient performance in superheated steam locomotives and if a portion of the superheating surface is given over to the evaporation of water the degree of superheat obtained will be proportionately lower. It must be borne in mind that the superheater cannot be expected to give the results for which it is intended if it has to assist in the work which should be done by the boiler.

Sweeping Changes in Officers

It is difficult to understand the reasoning of a man who, when placed in charge of a railway organization, or a part of one, begins deliberately to pull it to pieces. We refer particularly to cases arising from time to time in which the previous officer has died or left the road for service elsewhere, and in which the organization has been known for its effectiveness. A superintendent of motive power, for example, when appointed under such conditions may start to "clean out" the motive power department staff. If he is a man who has been

"brought up" on that particular road, the changes which he makes are likely to be because of personal animus or inability to get along with certain individuals; and whether he be promoted or brought from another road, he is quite likely to make a number of changes, just to "make a showing." If men of this caliber were to stop and think carefully over such proposed changes before they are made, it is not likely that so many of them would be made. Changing officers who are known to be producing results is likely to prove expensive. The new man not only has to learn the conditions about him and become familiar with his subordinates, but he may take it into his head to take a leaf from his superior officer's book and institute a house-cleaning himself. It does not take any great amount of perception to see that moves of this kind are likely to have results similar to that of pushing over the first of a row of dominoes.

And who pays for it all? The railroad company, of course. In order that one officer might "make a name for himself," an organization is abruptly torn to pieces, and has to be slowly and painfully put together again—slowly, because no efficient organization can be made overnight; and painfully because the new men, in becoming accustomed to their duties and learning to work in harmony with other departments, necessarily make mistakes which are very likely to cause engine and train delays and otherwise increase expenses. Admittedly, the new organization may eventually prove superior to the old one; but who can say that the old one could not have been made just as effective, and that without any preliminary upheaval? We have nothing to criticize in the changes made by an officer who has been placed in charge of a department which everyone knows was in bad condition; but even in such an instance the new man can afford to move slowly. The really big man in any case will make no change until convinced beyond a doubt that a change is necessary. We seriously doubt whether the "make a showing" tactics referred to really ever produce any remarkable and lasting results, and the man who practices them is more than likely to show only that he himself is not big enough to realize what an effective and efficient organization is.

Railway Fuel Convention

The most interesting subject presented for consideration at the seventh annual convention of the International Railway Fuel Association was that of pulverized fuel. The author of the paper, W. L. Robinson, of the Baltimore & Ohio, is to be congratulated upon the thoroughness with which he covered the field. The members were enthusiastic on this subject, many being of the opinion that by the use of pulverized coal the operation of the steam locomotive would be brought almost to perfection. Those who are the beginners in employing this method of firing must be prepared to meet the disappointments that are bound to occur with newly developed methods, but it is only by a willingness to experiment that the use of pulverized coal can be developed to the limit of its possibilities.

The committee reports on mechanical stokers and fuel stations are of special interest. Regarding the former, the association goes on record as to the permanency and necessity of the locomotive mechanical stoker for certain conditions. The report contains information obtained from various railroads replying to a list of some 25 or 30 questions. It brings the purposes, the operation and the value of the stoker clearly before the reader in a very concrete form. The committee on fuel stations presented very good information regarding methods of storing coal at the coaling stations.

Perhaps the most striking point brought out throughout the discussions was the seeming lack of interest displayed in fuel economy by persons other than those directly responsible for the fuel. It was felt that if more active consideration were given by the higher officers to this subject, much better results could be obtained. The fuel men should so fortify themselves with arguments and figures that they would have little difficulty in showing their superiors just what they could save by being given

additional authority or an increased supervising force. With about 25 per cent of the total transportation expenses chargeable to fuel, what may seem small percentages in savings may really mean considerable sums of money. It behooves each member of the Fuel Association, therefore, to boost on fuel economy. He has every opportunity to win his case.

The attendance at the convention was noteworthy, especially on account of the tendency this year for roads to refuse to pay the expenses of their men at the various conventions. The Baltimore & Ohio, one of these roads, was represented by 19 men, all paying their own expenses. This surely is a tribute to the association of which every member should be proud.

The Special Apprentice

Elsewhere in this issue will be found a communication from a special apprentice who questions the value to the apprentice as well as to his employer of certain methods followed in the training of special apprentices. This re-opens a discussion to which much has already been contributed with, we fear, but little effective result. It is evident from the amount of discussion which has taken place, however, that the special apprenticeship course usually found in the railway mechanical department leaves much to be desired. The apprentices complain of the length of the course and of the opportunities offered, as well as of the treatment to which they are subjected. Mechanical department officers and foremen are often disappointed with the services rendered by the special apprentices and contend that their future is largely in their own hands. So far the remedies suggested have almost exclusively dealt with the length and adjustment of the course. They have dealt with the symptoms of the malady but have not touched its source.

In the traditions of the railway mechanical department the college man plays but a small part. The training of the mechanical department officer has long begun with his trade apprenticeship at such an early age as to preclude the possibility of attaining more than a common school education. The need of college men in the department has long been felt but the problem of creating a practicable avenue of entrance has been difficult of solution; indeed it has not yet been solved. The young man who has spent four years or more in acquiring a technical education very naturally feels that he cannot afford to enter railway service as a regular apprentice in competition with others who are from four to six years younger. He expects, to a certain extent, immediately to capitalize the training he has received; hence the necessity of the extra inducement in order to secure his services at all. The special apprenticeship course is the inducement now offered, and many college men take up the work of such a course under the false impression that they are to be given a short cut, from which the rough places have been eliminated, to a high place in the organization. Disillusionment comes after a few weeks of sore muscles and blistered hands and with it a feeling of resentment. Of course, not all apprentices succumb at this stage in their development; those of the right stuff in time readjust themselves to the actual conditions and settle down to make the most of the many opportunities which lie in their path. The point is, however, that what is intended as a special inducement is in reality a handicap both in securing the right kind of material and in its best development when once secured. Another evil of the special apprenticeship system lies in the fact that it practically limits the development of those who enter the service at the bottom as regular apprentices, creating a condition at the outset which is fundamentally wrong.

The elements of a better solution of the problem may be found in the methods employed in the instruction of regular apprentices on many railroads at the present time. The need of certain standards of education for mechanics, higher than possessed by the average applicant for apprenticeship, has led to the inclusion of class-room work in the regular apprenticeship course, a practice which has been amply justified by its results. If the maintenance of school facilities for the education of prospective mechanics is

economical, are the railways not equally justified in making some provision for the higher education of prospective officers selected from tested material? Scholarships in reputable technical institutions properly equipped to teach railway mechanical engineering could be developed to fulfill admirably the requirements of the railways. These could then be filled from the ranks of regular apprentices, just as some of the American Railway Master Mechanics' Association scholarships are now filled. Such a plan would undoubtedly require a greater outlay by the railroads than does the present system of special apprenticeship, but the result would be far better. The grounds for the misunderstanding which so frequently exists between the college man and his employer would be removed, and the elimination of those unfitted for railway mechanical work, or for positions of responsibility, would take place before, instead of after, several years have been wasted in expensive preparation for the work. Young men thus receiving their early training in the mechanical department will return to the service after a college course with a true perception of the relation of theoretical training to practical results—something which the special apprentice acquires only after much disappointment and readjustment.

The Art of Braking Trains

The advent of the steam locomotive with the consequent increase in the speed of movement as compared with the previous methods of transportation created the problem of braking, which previous to that time had been successfully solved by the simplest of mechanical appliances. That the need of more effective means of controlling the speed of trains was evident early in the development of railroading is shown by the fact that during the first two-thirds of the nineteenth century more than 600 patents covering brakes of various kinds for railroad service were granted in England, while about 300 were granted in the United States. The real history of successful train braking, however, began in 1872 when George Westinghouse brought out the first automatic air brake, this undoubtedly being the greatest single advance step in the development of the art. The underlying principles in the construction of this brake are universally adhered to in American practice today, and its further development has been a large factor in increasing the speed and weight of trains, which has resulted in increasing the efficiency of the service rendered by the railroads.

With the light equipment and comparatively short trains handled during the early days of the automatic air brake the functions essential to satisfactory train control were comparatively few and the apparatus was simple. The maximum conditions in freight service did not then exceed 40 or 50 cars per train with a maximum capacity per car of 50,000 lb., while passenger trains did not often exceed five or six cars of light wooden construction. Today freight trains of 100 cars are not uncommon, many of the cars having a capacity of 100,000 lb. and even greater. Passenger equipment has more than doubled in weight and trains of 15 or 16 cars are often handled. Under present conditions the simple functions of the early automatic brake are entirely inadequate and in meeting the changes in conditions many changes in the air brake apparatus have been made. As new functions have been required new apparatus has been added to the equipment until today the triple valve has been replaced on the locomotive and is being replaced on heavy passenger coaches by apparatus involving many complications. With the new equipments better results are obtained under the modern severe conditions than were obtained with the old equipment on shorter and lighter trains. The apparatus, however, has become so complicated that it is the work of a specialist to acquire even a general knowledge of its construction and maintenance.

One of the great needs in the field today is the simplification of the means employed in brake operation. This statement does not imply a lack of appreciation of the results accomplished by the present trend of development, which has undoubtedly taken a logical course, but we believe that we are voicing the opinion

of many railroad men in stating that such a simplification is now greatly to be desired, from a maintenance standpoint as well as in order to further the development of better freight train control. With brake equipment now being placed on passenger train cars the engineman has as perfect control over brake cylinder pressure as though each cylinder in the train were supplied with air direct from the locomotive. With freight train cars, however, this is not true and to maintain effective cylinder pressure against brake cylinder leakage, release and reapplication are still necessary. While perfect control of brake cylinder pressure may not be as essential in freight as in passenger service it is none the less desirable. Such control is not impossible of attainment at the present time but the cost of the necessary apparatus as well as the conditions under which it would operate are prohibitive from a practicable standpoint and it can best be made available for freight service by a reduction of the complexity of the appliances required.

It would therefore seem that the advantages to be gained by a modification in the present systems of air brake control, whereby the advantages of such functions as the maintenance of uniform and constant brake cylinder pressure regardless of cylinder leakage and unequal piston travel, and others now possible in passenger service may be made available for freight service, are worthy of the serious consideration of the builders of air brake equipment as well as of the few railroad men who are specialists in air brake performance and maintenance. Whether such a result is possible of practicable attainment is not our place to say; it is not inherently impossible, however, and the need is great.

NEW BOOKS

Proceedings of the American Electric Railway Association. 555 pages, 6 in. by 9 in. Illustrated and indexed. Bound in cloth. Published by the American Electric Railway Association, 29 West 39th street, New York.

This is the complete proceedings of the American Electric Railway Engineering Association's twelfth annual convention, held at Atlantic City, N. J., October 12 to 16, 1914, and contains much valuable information concerning engineering as applied to electric railways. The printing is especially good and the illustrations clear, the latter including a number of insets.

Tests of Metals and Other Materials. Bound in cloth. 213 pages, 5½ in. by 9 in. Illustrated and indexed. Published by the United States War Department, Washington, D. C.

This book comprises the 1914 report of the tests made on metals and other materials with the United States testing machine at Watertown Arsenal, Mass. The tests covered are those up to June 30, 1914, and include tests on steel columns, chains, wire and manila rope, proof stresses on piston rods as well as metallographic examinations. A large number of illustrations are included, among them being several insets and the entire work is done with the usual high quality of the government printing office at Washington.

Rules for the Construction of Stationary Boilers. Bound in paper. 114 pages, 6 in. by 9 in. Published by the American Society of Mechanical Engineers, 29 West 39th street, New York. Price 80 cents for individual orders; 40 cents per copy in lots less than 1,000; 30 cents per copy in lots of 1,000 to 2,000, and 20 cents per copy in lots of 2,000 or over.

This book constitutes the report of the committee of the American Society of Mechanical Engineers to formulate standard specifications for the construction of steam boilers and other pressure vessels and for their care in service. This committee is known as the Boiler Code Committee and has spent several years on the development of this set of rules. Its members comprise some of the most eminent mechanical engineers in the country, and every endeavor has been made to formulate a set of rules which will be thoroughly practical and can be adopted in their entirety by any state or municipality.

COMMUNICATIONS

THE SPECIAL APPRENTICE

READING, Pa.

TO THE EDITOR:

I have read with great interest the articles about apprentices and apprentice instruction, appearing from time to time in your columns. In line with a request in an editorial in your April issue, I wish to make the following suggestions:

It seems to me that special apprentices in American railroad shops spend too much time in one place. For instance, why should they be kept at such work as tapping holes in boilers for a month or more—an operation which anyone can learn in one or two days? Is it not a waste of time to spend weeks on a class of bench work that is every day the same, and can be done as well by laborers? There are many cases of this kind. When a special apprentice has spent a good many years in school, it is to his interest, as well as that of his employer, that he have an opportunity to learn something new every day, and not to be forced to do the same work over again and again. There has been much discussion as to why so many apprentices leave railroad work to enter other fields. I believe that if they were kept interested in their work, as they would be if they were moved about more frequently, they would stay with the railroad.

Furthermore I would recommend that during their course special apprentices be placed in charge of a small gang to find out which ones are qualified to become foremen. There are many men who can do good work themselves, but are unable to direct others, while on the other hand, there are many less skilled workmen who have the ability to supervise others.

Finally, I believe for special apprentices, two years of shop-work should be sufficient. In Germany the college apprentices work only one year, but I believe that is rather short. If a two-year course were adopted, the time could be divided as follows:

Machine shop	4 months
Air brake department	1 month
Blacksmith shop	1 month
Carpenter shop	1 month
Foundry (Iron and Brass)	2 months
Boiler shop	2 months
Erecting shop	3 months
Roundhouse	2 months
Firing engines	2 months
Car shops	3 months
Drawing room	3 months
	24 months

This should be long enough to acquire a fair knowledge of the work done in each department. When his course is completed he could be kept in the drawing room until other work is available.

HERMANN SCHOENEN.

KEEPING UP STANDARDS ON METALLIC PACKING EQUIPMENT

CHICAGO, Ill.

TO THE EDITOR:

It has occurred to the writer that railroads could save quite a bit of money and obtain much better results with metallic packing, all makes considered, if all vibrating cups were made in one shop. Very few roads do this, although the cups could be made more uniformly and a great deal cheaper if they did. The main objection of mechanical department officers is that the cups are usually bored to fit the rods. Granted; but why not leave that part of the cups small, and when a new cup is required simply draw one from the storehouse and bore it out to fit the rod? I venture to say that vibrating cups made in quantities with the proper tools and devices can be made for one-half what, for instance, a small roundhouse shop could make them; also—and here is the main reason for having cups made in one shop—the cups will all be alike over the entire system. The writer has seen about 57 different varieties of the same type of cup on one road, some made without even a template. How can the same packing possibly fit more than one kind of cup?

In the making of vibrating cups even a poor system and

standard is better than none. Of course, it should be patent to anyone that some real standard should be adopted for each kind of packing used; then all the cups should be made to that standard. Solid reamers should be used and these kept to a standard by a master cup, or some other good method to insure uniformity. It would probably surprise the mechanical department officers after a few months to note that a great deal less packing was being used and that what was used was working the way it should. The writer would be very glad to do what he consistently can in the way of suggestions. A. E. M.

BRAKE HANGING AND THE M. C. B. JOURNAL BEARING

BOSTON, Mass.

TO THE EDITOR:

There seem to be two common misconceptions concerning brake hangers; one is that the hanger on the forward wheel is placed in compression immediately when the brake is applied; the other is that the angle of the hanger has an important bearing on the chattering of the brake. Yet the behavior of the apparatus does not agree with these conclusions.

In the figure *AB* is the force with which a brake is applied. At high speed the coefficient of friction between the wheel and shoe is low; *AD* represents the resultant reaction of the wheel against the shoe with a coefficient of friction of 0.125, *AC* being the pressure between them. The combination of *AB* and *AD* gives *AF*, the resultant stress in the hanger, in this case tension. As the speed is reduced the coefficient of friction increases. The

- AB* = force delivered by lever
- AC* = pressure of shoe against wheel
- AD* = reaction of wheel with coefficient of friction of 0.125
- AE* = reaction of wheel with coefficient of friction of 0.333
- AF* and *AG* are the respective resulting stresses in the hanger

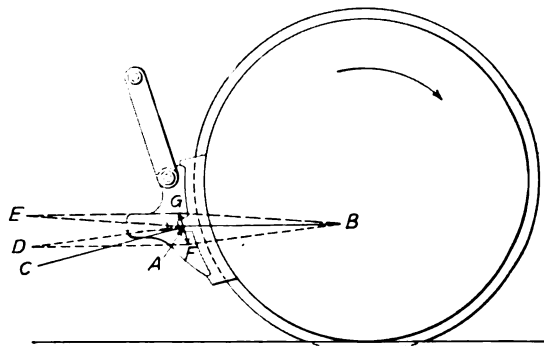

Diagram illustrating the Stress in Brake Hangers

resultant stress in the hanger is the compression, *AG*. As the coefficient increased, it passed through a certain value, about 0.25, which resulted in no stress in the hanger. A slight further increase throws the head quickly upward. When the slack is taken up, the elasticity of the hanger throws it down, because the tendency to compression is still slight. This is repeated until the increasing friction stops it, and we know this action as "chattering." It does not begin until speed has been reduced, and usually stops just before the train stops.

A brake hung at the height of the center of the wheel would throw its hanger into compression at once, and should not chatter. It would have the further advantage of being unaffected by the height of the springs as determined by the load in the car, and would be in an ideal location. The only objection to this seems to be the effect on the journal bearing. Has not the time come when the bearing should be extended down the sides of the journal? There is naturally much reluctance about changing standards, but additional parts and maintenance expense are often resorted to for advantages of less importance. G. E.

FUEL ASSOCIATION CONVENTION

Papers on Powdered Coal, Prevention of Smoke, Fuel Stations, Mechanical Stokers and Fuel Oil

The seventh annual convention of the International Railway Fuel Association was held in the La Salle Hotel, Chicago, May 17 to 20, D. R. MacBain, superintendent motive power and rolling stock New York Central west of Buffalo, presiding. The convention was opened with prayer by Rev. John W. Nicely.

PRESIDENT'S ADDRESS

Mr. MacBain said in part: "I am a great believer in the educational phase of the question of fuel. To render efficient service economically in any particular line, familiarity with its details is essential, and this is the more particularly true, perhaps, in the case of the man who actually handles the coal between the locomotive tender and the firebox. For fuel might be purchased with the utmost skill, receive the best attention as to grade and preparation by the railroad company's inspectors, be carefully passed from the coaling plant to the tender and then might be subjected to the grossest kind of misuse and extravagance. The firemen need practical instruction on the road, the more they get the better, and the more efficient and economical will be their services. With this practice in vogue, I am positive that the salaries of the instructors will appear as assets, doubled and trebled, on the auditors' books."

ADDRESS BY MR. SCHOYER

A. M. Schoyer, resident vice-president, Pennsylvania Lines West, made a most interesting address after commenting on the very creditable work of the fuel association. In his address, he said in part:

"It seems to me that one of the burning questions of the day, from a railroad standpoint, is, What shall the railroads do either to offset the continuing demand for increased wages or to get the relation of employer and employee on a sounder basis, where right will be considered, instead of might or expediency?"

"Three remedies have been suggested—first, government ownership of railroads. With ward politicians acting as general managers, state politicians handling the policy, national politicians handling the finances and labor leaders handling the labor questions, there would be no need of arbitration for the wages would be increased upon the asking. With the railroads in the hands of the government, with rates probably continually being decreased, in order to favor special lines of voters, and with wages being increased to favor special lines of labor unions, with incompetent supervision of details the growing deficits would have to be raised by taxation, and it is quite certain to my mind that the result of such losing operations would be that the credit of the government would suffer and rates of interest go higher and higher.

"The second solution, which has been suggested, is that if the law should provide and the Interstate Commerce Commission should authorize that whenever railroads must through arbitration increase the wages of the employees in any branch of service they be also authorized to increase their freight rates automatically. If an arbitration should give the men an increase of wages of 6 per cent, then the railroads should be authorized to increase freight rates, say 3 per cent. How long the public generally would stand it I do not know.

"With very great diffidence I bring forward a third solution, compulsory arbitration. Not arbitration as under the Canadian law, which is not entirely compulsory; not arbitration as under the American law, which is entirely optional; not arbitration as exists in any country today; but a law which would compel employer and employee to submit their differences to a court of arbitration, after having done all they could together to solve them. The law should require that no lockout or strike should

occur hereafter on railroads. The decision of the court should be binding; not to be appealed from, except as to errors of law appearing on the record. Neither the employers nor the employees would be willing to go to the limit of submitting matters to this court unless they were assured of the justice of their positions, and, in the course of time, labor and capital, as applied to the railroads, would find their own relations."

POWDERED COAL*

BY W. L. ROBINSON

Supervisor of Fuel Consumption, Baltimore & Ohio

Coal in a finely divided or powdered state represents the most advanced method for producing perfect combustion, thereby making it possible to more nearly obtain the full heat value of the fuel than by any other known means. While a cubic inch of solid coal exposes only 6 sq. in. for absorption and liberation of heat, a cubic inch of powdered coal exposes from 20 to 25 sq. ft., which enables the more uniform gas production from the volatile matter in the coal and the more prompt and perfect intermingling of gas and air, thereby improving combustion and reducing smoke. Furthermore, there is no cooling of the fire by heavy intermittent charges of fresh coal, and consequent production of lost heat, as with hand or stoker firing on grates.

The generally recognized waste, unsalable or otherwise low-value coal mine products, such as culm, slack, mine sweepings and dust, are suitable for converting into the powdered form. Therefore, much fuel that is now going to waste could be advantageously mined and utilized. The railways should utilize as much as possible of the inferior grades and qualities of local fuel supply available, in order to conserve the better mine output for commercial revenue tonnage in the domestic and foreign trade.

In general, powdered coal, to give the best results as regards complete combustion and the least trouble as regards ash and slag, should contain not more than 1 per cent moisture, and be of a uniform fineness, so that not less than 95 per cent will pass through a 100-mesh, and not less than 85 per cent through a 200-mesh, and not less than 70 per cent through a 300-mesh screen. The cost for preparing powdered coal will vary with the cost for the raw coal and its moisture content. However, a general average from available data covering periods of the past five to ten years at cement and metallurgical plants will enable the following conservative estimate, assuming the cost of the raw coal at from \$1 to \$2 per short ton, and that it will require crushing and have a moisture content of from 5 to 10 per cent, when placed in the dryer.

Capacity of plant in short tons per hour	Average total cost for preparation per short ton
2	From 25 to 50 cents
3	From 20 to 45 cents
4	From 16 to 40 cents
5	From 14 to 35 cents
10	From 12 to 30 cents
25	From 10 to 20 cents

The fuel required for drying the coal will average from 1 to 2 per cent of the coal dried. The distribution of the total cost may be approximately stated as:

Fuel for drying	10 per cent
Power for operation	30 per cent
Labor	30 per cent
Maintenance and supplies	25 per cent
Interest, taxes, insurance and depreciation	5 per cent
Total	100 per cent

The cost for preparing powdered coal should be more than offset by the ability to utilize the cheaper grades of fuel.

Finely divided coal dust gives off gas at normal atmospheric

*See also article on "Pulverized Fuel for Locomotives," published in the *Railway Age Gazette, Mechanical Edition*, May, 1915, page 213.—[EDITOR.]

temperature, but any pulverized coal coarser than that which will pass through a number 100-mesh screen is liable to explosion only when distilled by the heat or compression of a primary ignition. The finer than what will pass through a number 100-mesh screen carries no danger unless combined in a dry state, in floating suspension in nearly still air and mixed with the requisite amount of oxygen at the requisite temperature to produce "chemical tension" or primary ignition.

Powdered coal may be burned by either of two generally defined methods: The first, or long-flame method, constitutes a progressive burning of the coal. This combustion is accomplished by projecting the primary air which carries the fuel into the furnace with high velocity, the additional air (about 75 per cent) required for combustion being blown or induced into the furnace from other sources. The second, or short-flame method, has been the latest development. This process involves a flame of relatively short travel, and consists of admitting the entire air supply needed for combustion into the furnace with the fuel at low velocity. In the application of powdered coal to a New York Central locomotive, a combination of the long and short-flame methods has been used.

In general, the equipment essential for burning powdered coal in locomotives are: An enclosed fuel container; means for conveying the fuel to the feeders; means for commingling the fuel with air at the time of and after feeding; supplying the proper amount of air to produce a combustible mixture at the time the fuel and air finally enter the furnace; a suitable refractory-material furnace in the firebox; means for disposing of the slag; means for producing the proper draft through the furnace and the boiler; means for harmonizing the draft and the combustion; suitable power for operating the fuel and air feeding mechanism, and an automatic and hand control of the fuel and air regulation.

It is understood that the developed equipment for burning pulverized fuel can be readily applied to all existing modern types of steam locomotives without any changes in the fireboxes except to install arch brick supporting tubes, where fireboxes are not now equipped, and to remove the grates, ashpan and smokebox draft appliances. There is no equipment in the cab except the automatic hand control, which is placed in a position convenient to the fireman. The enclosed fuel container is suitable for either powdered coal or fuel oil, and either kind of fuel can be used by merely changing the feeding equipment. The total weight of the equipment applied will about equal that of the equipment removed.

For firing up a locomotive, the necessary draft through the boiler is obtained by means of the usual stack steam blower, after which a piece of lighted waste is placed in the fuel and air conduit leading to the firebox, and one of the fuel feeders is started.

SOME BENEFITS TO BE DERIVED FROM ITS USE

With powdered coal the tendency toward the more uniform, intense and sustained firebox temperature, as well as the automatic, continuous stoking of the fuel and the burning in suspension; feeding of practically dry fuel to the furnace; reduction in the clogging and leakage of flues and the reduction in the various heat losses, should all tend to maintain the boiler capacity at its maximum effectiveness under varying operating conditions.

Through the burning of powdered coal in suspension, the necessity for over or under-feeding fuel to grates or retorts is eliminated, and as there are no grate fires to require cleaning, it enables the establishing of the most economical length of locomotive run for the train service to be performed, and the reduction of engine house terminals. As locomotives burning oil are being regularly and successfully operated on runs from 300 to 450 miles each way, the same should be entirely feasible when burning powdered coal.

The use of bituminous coal in a powdered form seems to be

the logical solution of the smoke, cinder and spark questions at engine houses, terminals and on the road, and one that should greatly reduce the loss of heat and fuel cost resulting from imperfect combustion in existing and future steam locomotives.

The elimination of ash pans, grates, smokebox, diaphragm, baffles and nettings substantially reduces the retardation of the products of combustion through the boiler.

Furthermore, the coal is not touched by the hand or shovel from mine car to furnace and there is no loss by pilfering, dropping from the tender container, gangways, through holes in deck, or by firemen shoveling undesirable fuel off the tender on right-of-way.

When powdered fuel is used, the refractory-material furnace retains its heat and prevents the chilling of the firebox and flues, even though the supply of fuel may be cut off and therefore reduces the liability of firebox leakage.

When being worked at from one-half to maximum boiler horse power capacity, a locomotive boiler equipped with a superheater will range from 65 to 55 per cent boiler efficiency, this being representative of the best grate fire practice. Taking into consideration the effect of burning powdered coal in suspension on the various heat losses enumerated, it is most conservative to place the saving to be effected at 25 per cent of the coal fired, actual performance to date having shown as high as from 30 to 40 per cent saving.

The time required for building, cleaning or dumping fires at terminals and cleaning flues and smokeboxes on steam locomotives represents a large percentage of the maximum non-productive delay to power, and is directly responsible for much road and yard crew and shop labor expense. With powdered coal there are no grate fires to clean; the extremely fine nature of the ash and absence of cinders causes practically no accumulation in the flues or smokebox.

As the sulphurous and other poisonous gases resulting from combustion tend to precipitate with the liquid ash into slag, the poisonous and suffocating effect of the products of combustion emitted from the stack is materially reduced.

The use of powdered coal (due to absence of cinders, sparks, ashes, etc.), would reduce cementing of ballast and lack of drainage of roadway, burned out ties and the cost for forking ballast. With powdered coal and automatic mechanical mixing of the fuel and air and its combustion in suspension, no manual labor is required, and the human element is practically eliminated.

DISCUSSION

The members participated freely in the discussion, there being some skepticism as to the ultimate outcome of the use of powdered coal. E. H. Stroud, of E. H. Stroud & Company, stated that the coal must be powdered to the correct fineness and that it must be uniformly fine if the best results are to be obtained. Complete combustion must be obtained to prevent the formation of cinder slag and if the furnace is correctly designed there should be no trouble with the accumulation of slag on the flues. The air and the fuel passed through the burner should be definitely measured, and to accomplish this he strongly recommended that the air necessary for the complete combustion of the powdered fuel be admitted only through the burner. Where air is used to separate the fine from the coarse particles in the process of pulverizing—a coal with 10 per cent moisture will be reduced to 7 or 8 per cent moisture. He also recommended a lazy flame, stating that in stationary plants this would give a temperature that could be regulated from 1,800 to 3,600 degs. F. In this same service savings as high as 50 per cent in fuel of a low price have been made. He gave estimates of 15 cents per ton as the cost for pulverizing fuel at the rate of 5 tons per hour and 4 to 5 cents per ton for drying the coal. From his experience he found that a draft of only $\frac{3}{8}$ in. (water column) was required. He recommended a coal with not less than 25 per cent volatile.

Joseph Harrington, of the Powdered Coal Engineering & Equipment Company, called attention to the effect the use of

powdered coal on locomotives would have in postponing the necessity of electrification at large terminals such as Chicago, and spoke to some extent on the large field this type of fuel offers to the railroads.

J. E. Muhlfeld, president of the Locomotive Pulverized Fuel Company, presented a written discussion, in which he confirmed the conclusions derived from Mr. Robinson's paper. He showed that if the powdered coal equipment was applied to all types of locomotives an annual saving of millions of dollars could be made in the cost of fuel to the railways, and that the operation of the locomotives would depend less on the physical capacity of the firemen.

Other speakers who have had experience in the use of powdered coal spoke strongly in its favor, and all called attention to the necessity of having the powdered fuel dry, the maximum moisture being placed at 2 per cent. The users of this fuel find it expedient to keep only 48 hours' supply on hand to prevent the possibility of the coal to absorb too much moisture.

Mr. Robinson stated in his closure that tests have shown that only 15 lb. of dust was found in the locomotive front end after a test of two weeks and that evaporation of 8½ to 12 lb., from and at 212 deg., had been obtained.

ANALYSIS OF DEPENDENT SEQUENCE AS A GUIDE TO FUEL ECONOMIES

BY HARRINGTON EMERSON

The Emerson Company, Efficiency Engineers, New York

With a good steam engine, a good furnace and a good boiler, a horsepower can be produced from one pound to a pound and a half of coal. The steamers of the Inch Line have long records of one pound per 1 hp. The Lusitania, with all her auxiliaries, used about 1.5 lb. The indicated horsepower generated by all the locomotives of the country when pulling trains, divided into the total fuel, amounts to between 4 and 6 lb. I intend to speak of such attainable ameliorations in our locomotive practice as might reduce the 6 to 4, the 4 possibly to 3.

To bring about attainable reductions, there are three essentials: Complete knowledge of what is taking place from mine to ash pit; an organization that is capable of taking hold of the subject; an organization that is competent to solve the problems.

The first step towards the solution of the problem is to set down what we do know of all the steps from mine to ash pit. It will be found that there are some sixty different, distinct steps and that they form what is technically called a dependent sequence. Unlike the links of a chain, which are in dependent sequence, the use of coal is one in which any loss that occurs in the first term is carried on into the second, the losses in the second link or term are carried on into the third link, and we suddenly find we have frittered away all the strength there was.

DEPENDENT SEQUENCES IN COAL USE IN LOCOMOTIVE OPERATION

Sequences			
1 to 23	A	Administrative inefficiencies	51 per cent
24 to 32	B	Shrinks in quantity between purchase and use	92 per cent
33 to 45	C	Wastes due to poor design.....	69 per cent
46 to 52	D	Wastes due to poor firing.....	71 per cent
53 to 58	E	Wastes due to poor running.....	88 per cent
			<hr/>
			58
			20 per cent

Probably in no case do all the possible losses occur cumulating on any single road, but probably on every road there are at least 30 different kinds of losses. As to each of the fifty-eight a separate analysis would be desirable, an analysis that each must make for himself. I shall content myself with a few indications and a very elementary estimate of the loss that may be occurring.

A.—Administrative Losses.—These far exceed all others, but it is the fireman and engineer who get the most blame.

1—Eff. 99.5 per cent. Buying too much coal. Coal costs money and money carries interest.

2—Eff. 96 per cent. Paying too much. This is much more serious. Coal contains B. t. u's, and this is all that makes it valuable.

3—Eff. 95 per cent. Buying wrong kind of coal (clinking, coking, etc.). The type of coal may make a very great difference.

4—Eff. 94 per cent. Unnecessary transportation. Probably \$0.60 a ton is added to cost of coal on long roads by transportation charges, of which \$0.06 might be saved by wise routing.

5—Eff. 98 per cent. Unnecessary handling expenses, loading and unloading, detention of cars, etc.

6. Eff. 90 per cent. Wrong sizing of coal. A. G. Kinyon, a recognized authority, estimates the difference between properly sized coal and usual run at 10 per cent.

7—Eff. 98 per cent. Loss in value of coal due to weathering.

8—Eff. 99.7 per cent. Moisture in coal. Even if the coal absorbs 5 per cent of moisture the loss is small, about one-third of one per cent.

9—Eff. 99 per cent. Bad water conditions, indirectly affecting coal consumption. Our experience has been that when water was very bad, coal consumption for similar trains and locomotives is higher.

10—Eff. 95 per cent. Scale on tubes and other fire surfaces. F. W. Foltz, fuel supervisor of the Missouri Pacific, stated that the fuel losses due to this cause were enormous. They undoubtedly might be far worse than the 5 per cent allowed.

11—Eff. 99.7 per cent. Leaks from boiler.

12—Eff. 99 per cent. Broken grates. Causing excess of air and waste of coal before being burned.

13—Eff. 97 per cent. Use of cold water and frequent changes. On a road using 6,000,000 ton, this loss probably amounts to \$200,000 a year.

14-15-16-17—Eff. 85 per cent. Terminal and roundhouse losses. Mr. Foltz's estimate of terminal and roundhouse losses is 15 to 30 per cent of total fuel bill.

18—Eff. 98 per cent. Detentions on side tracks.

19—Eff. 99 per cent. Short sidings and other unnecessary see-sawing of trains.

20—Eff. 99 per cent. Uneconomical grades.

21—Eff. 98 per cent. Uneconomical loading.

22—Eff. 98 per cent. Wrong assignment of power.

23—Eff. 98 per cent. Unscientific time schedules. Based on distance rather than grades.

If all these inefficiencies should occur on the same road, only one as high as 10 per cent, many of them less than 1 per cent, the end result would be under 51 per cent.

B.—Shrinks in Quantity Between Purchase and Use.—The locomotive is generally charged with coal purchased, not with coal used. These losses are partly due to dishonesty and partly due to carelessness.

24—Eff. 99 per cent. Incorrect mine weights (dishonesty).

25—Eff. 99.5 per cent. Incorrect car weights (carelessness).

26—Eff. 98 per cent. Biased weigher.

27-28-29-30—Eff. 97.5 per cent. Loss in transit (coal that drops off or is thrown off, loss in loading tenders, loss from tenders).

31—Eff. 99 per cent. Diversion from coal in transit. I knew a flouring mill which operated for a year on stolen coal, whole car loads being diverted, after being weighed and charged to coal bunkers.

32—Eff. 99 per cent. There are other diversions, as when coal from bunkers is used for office and roundhouse fires, etc., coal used perhaps for company but not used on locomotives. These dishonesties and semi-dishonesties amount perhaps to as much as 2 per cent. The end result is about 92 per cent.

C.—Waste Due to Poor Design.—The best stationary steam engines use about one pound of coal per 1 hp. The ordinary commercial steam engines use from 3 lb. to 20 lb. The conditions under which a locomotive operates are extraordinarily difficult. The power installation is mounted on wheels, the machinery must be rugged rather than accurately finished. Every element of standard operation varies from minute to minute. The fuel, the water, the load varies. It is, therefore, inevitable that severe losses occur from poor design. In good stationary practice 80 per cent of the heat in the coal passes into the water. In locomotive practice very rarely as much as 50 per cent. There is, therefore, a shrink of about 30 per cent in coal efficiency to be charged to design and conditions of operation. Two-fifths of this might possibly be eliminated and if distributed might be apportioned as follows:

33—Eff. 99 per cent. Design of firebox.

34—Eff. 98 per cent. Size of firebox.

35—Eff. 95 per cent. Diameter and length of tubes.

36—Eff. 95 per cent. Front end design. In an English test 375 hp. out of 2,000 was used in creating draft. M. C. M. Hatch, superintendent fuel service, D. L. & W., states that only 19 per cent of front end vacuum is effective at fire.

37—Eff. 98 per cent. Poor ash pan design. Air openings should be 14 per cent of grate openings and about 100 per cent of tube opening area.

38—Eff. 98 per cent. Grate openings.

39—Eff. 95 per cent. Radiation.

40—Eff. 95 per cent. Economies due to compounding do not become manifest unless the pressure exceeds 180 lb. Can be estimated at 5 per cent.

41—Eff. 95 per cent. Economies due to superheat.

42—Eff. 98 per cent. Preventable friction in machinery, valves, pistons, rods, bearings.

43—Eff. 99 per cent. Wheels of different diameter, as either ahead or slightly shifted from middle line.

44—Eff. 99 per cent. The difference in economy between high and low steam pressure is discernible.

45—Eff. 99 per cent. Direction of draft through locomotive. End result is about 69 per cent.

D.—Wastes Due to Poor Firing.

46—Eff. 99.5 per cent. Building fires. The loss is relatively great, but on the aggregate, small.

47—Eff. 95 per cent. Smoke and sparks. Too little air. M. C. M. Hatch states that at 2,000 lb. coal fired per hour, the coal loss in sparks is 1.5 per cent; at 7,000 lb. it is 12 per cent. To put the loss in smoke and sparks at 5 per cent is conservative.

48—Eff. 80 per cent. Too much air. This is an invisible but serious loss. Assume 50 lb. excess of air for each pound of coal, the air heated 800 deg. Can lose 0.0686 B. t. u. per lb. per degree. For 800 deg. 54.88 B. t. u's. For 50 lb. excess air this gives 2,744 B. t. u's, or about 20 per cent of the heat units in very good coal. The loss might therefore be 20 per cent.

49—Eff. 98 per cent. Popping and plume—too high pressure.

50—Eff. 99 per cent. Too low pressure. The lower the pressure the less the efficiency of the steam engine.

51—Eff. 99 per cent. Cleaning fires wastefully.

52—Eff. 98 per cent. Dumping fires.

E.—Waste Due to Poor Running.—This paper is on a theory and on a method and does not assume to give any proof of the actual losses, which may be more or less than estimated. Undoubtedly losses exist due to poor running, for I have seen letters from firemen narrating the excessive work put on them, and the coal wasted by bad running.

53—Eff. 99.5 per cent. Slipping drivers (harder on the drivers and rails than on the coal pits).

54—Eff. 98 per cent. Full stroke. A train might very easily waste time at a station and the engineer try to make it up by extra steam on the road.

55—Eff. 99 per cent. Throttling in combination with full stroke results in greater steam consumption.

56—Eff. 95 per cent. Dynamometer car tests show variation in horsepower and constant speed when constant horsepower and variable speed is more economical.

57—Eff. 98 per cent. Unwise acceleration. A great consumption of power to gain a few seconds in time.

58—Eff. 98 per cent. Unnecessary braking. End result is about 88 per cent.

If we take the combined efficiency of the engineer and fireman, it appears to be 62.5 per cent, or almost two-thirds. But a test made on a switch locomotive reported in *Erie Employes' Magazine* showed that current consumption of coal was reduced 65 per cent by care, not 33 per cent. Tests have been made both as to passenger and freight runs, which show actual consumptions under dynamometer-car records amounting to only one-third of usually charged consumption. On such runs, wastes due to poor design and to interest charges, to paying too much, to unnecessary transportation and to unnecessary handling expenses, are not eliminated, nor losses due to weathering.

Eliminating these we would have the following major sequences:

A	Administrative inefficiencies	60	per cent
B	Shrinks in quantity	92	per cent
D	Poor firing	71	per cent
E	Poor running	88	per cent

End result34.5 per cent

This sequence in its end result of 20 per cent to 35 per cent checks up well with the special tests made, checks up well with the difference between coal actually required for horsepower generated and the coal charged to the locomotive fuel account.

To correct the cumulative result in dependent sequence of a number of small evils there should be reliable, immediate and adequate records available from mine to ash pit; an organization capable of handling the problems, and an organization competent to solve the problems.

Railroad locomotive practice is defective as to all these conditions. The records are unreliable, deferred and inadequate.

Railroads are very slowly outgrowing the belief that a line officer also necessarily possesses staff competence. The fuel problem is a bigger one than records and a specialized organization. These are the tools wherewith results can be obtained, but before we use tools we must have an organization able to use them, an organization competent to expand and supplement the present cramped type.

DISCUSSION

The paper was well received, the members approving of the broad basis on which it was written. The subject of fuel economies is of so vital importance that all of the higher railroad officers should take an active interest in it. While the mechanical department is directly interested in the consumption of fuel, there are a great number of ways in which the other departments can assist substantially in saving fuel. For this reason it is believed that more decisive action should be taken by the officers in order that the necessary authority be given for a comprehensive and effective fuel economy campaign.

W. C. Hayes, Erie, spoke of some dynamometer tests that had shown that it was possible to operate on 87 lb. of coal per 1,000 ton-miles where 175 to 180 lb. had been considered a good average, illustrating what could be accomplished by proper supervision. A. G. Kinyon believed that the men should be taught to think more concerning their work. The locomotives should be carefully maintained and special attention should be given the steam leaks in the front end, as this is a large source of fuel extravagance.

By looking for and correcting the small imperfections, large savings can be made. The large defects will make themselves known.

SMOKE PREVENTION

BY E. W. PRATT

Assistant Superintendent Motive Power and Machinery, Chicago & North Western

In 1912 and 1913 elaborate tests were made on the locomotive testing plant of the Pennsylvania Railroad at Altoona, Pa., and a complete report made in 1913 to the American Railway Master Mechanics' Association, with recommendations covering the application of steam-air jets, quick-action blower valves, etc. Since that time practically every locomotive operating in the city of Chicago has been equipped with such apparatus and it has been conclusively proven that soft coal burning locomotives may thereby be kept comparatively free from smoke if the engine crew be given and observe proper instructions at all times.

The smoke inspection bureau of the city of Chicago has accepted these devices as standards and recommends them to those inquiring. This bureau consists of the city smoke inspector, two assistants, ten mechanical engineers and nine deputy observers, covering not only the railroads but the entire city. The expense to the city is about \$39,000 per year. The railroads in Chicago have a total of 54 smoke inspectors representing an annual expenditure of about \$65,000. A railroad smoke inspectors' bureau, under the direction of a sub-committee of the General Managers' Association of Chicago, has been formed. This is composed of the chief smoke inspectors of all railroads in the city and holds its meetings bi-weekly, inviting thereto all railroad men interested in smoke prevention.

The railroad inspectors are required to report all engines they observe emitting dense smoke on a duplicate post card printed with the form shown herewith. One part of the card is mailed to the joint smoke inspection bureau through the U. S. mails, and the other is sent to the proper officer of the violating road through the railway mails. The bureau makes bi-weekly summaries of the reports for the different roads showing the number of reports filed, the number of locomotives operated in Chicago, the percentage of locomotives reported, the average density of the cases reported and the number of reports made by the inspectors of each railroad. These reports are for the private use of the railroads and are not furnished the city. However,

the work of the railroad bureau is heartily approved by the city authorities and has been productive of greater co-operation between the various railroads, so much so that the smoke reading made by the city the year following its inception was over 50 per cent lower.

At the present time all city inspectors are instructed to each read locomotive smoke for a total of two hours each day. This to be done in one period or in several periods of 15 minutes or more. These inspectors being assigned to various districts in the city make it certain that the railroad observations will not be confined to any one locality. From these observations the city issues monthly and semi-annual reports. All readings are made in accordance with the Ringlemann method of determining smoke density and the *engine minute* is the unit employed. It should be understood that the city smoke bureau construes one minute of No. 3, 4 or 5 smoke as a violation of the law.

An *engine minute* covers the observation of one locomotive during the entire minute. During this minute 14 seconds or less is not counted; 15 to 44 seconds is counted as one-half minute; 45 to 74 seconds is reported as a full engine minute. One-half minute of No. 3 density is 1.5. One-half minute of No. 1 density is 0.5, etc. The per cent smoke density is obtained by multiplying the smoke units by twenty (each Ringlemann unit being 20 per cent) and dividing the product by the total engine minutes.

In order that the city inspectors shall read the smoke density

do not anticipate the demands of the populace they too will find themselves bound by city ordinances. Smokeless firing can be obtained, but the engine crew must be properly instructed and supervised.

STANDARDIZATION OF COAL PREPARATION

BY H. C. ADAMS
President Jones & Adams Coal Company

The present method of screening has caused no end of trouble in marketing the coal, and various losses to the producer. There is never a time in the year when a market can be found to fit the various sizes that are now being made. This results in large quantities of coal being put on the market for any price the customer is willing to pay. It displaces the size the consumer would ordinarily use and which the operator wants him to use, and destroys any profit that might be secured.

The benefits of standardization are numerous: It would reduce the output to a point where the mine would get running time that would greatly reduce the cost. A great many cars that are now constantly tied up with unsalable sizes would be released and could be used for any other purpose. The operator would not be producing two or three tons of sizes that he has no market for in order to get a ton of the size coal he wants. The railroads for their fuel could use either inch-and-a-quarter lump or mine run, as they deem best, and either of these sizes could be produced in quantities required at all times, for the reason that no unsalable sizes would be produced in order to supply railroad coal. The railways are and should be interested in any move that will benefit the operator. A very large percentage of the freight of some of the roads is coal, and when coal cannot find a market, or perhaps finds an unprofitable market, the railway is sure to feel the effect in the lessened prosperity of the operator and his inability to seek broader markets.

FUEL STATIONS

The committee deemed it advisable to consider three separate and distinct sub-divisions of the subject as follows: Plant storage for reloading through the medium of cars; plant storage for direct issue to plant, and central storage for distribution to miscellaneous plants. The committee suggests the use of a locomotive crane with a clamshell or similar device for unloading and reloading storage coal, where the amount to be stored is less than 5,000 tons and where the daily issues are small enough to permit of its use.

A cheap method of unloading cars is to use a trestle from which the coal can be automatically dumped. Such a plant could be located adjacent to the coaling station, if the space is not too restricted and the track arrangements permit. Another method is to erect a timber trestle adjacent to the track as shown in Fig. 1, on which locomotives are coaled and grates cleaned, provided with a runway for a locomotive crane equipped with a clamshell or grab bucket. A plank wall or barrier should be placed along the side of the trestle contiguous to the storage pile, to prevent the coal from accumulating under the trestle. A strip of land about 60 ft. wide, and varying in length in proportion to the capacity of the pile would be required for storage. The plan provides for a capacity of 28 tons per lineal foot of coal pile. The coal will be delivered to the coal-receiving track (on the outside of the engine track) in gondola cars of practically any type, from which it will be removed and transferred to the storage pile by the locomotive crane. If desired, this plant may be used for coaling engines either from cars on the receiving track or from the storage pile. It is not considered advisable to use this plant as a locomotive coaling station at terminals where a large number of engines are coaled.

From somewhat meagre figures available it is estimated that with these plans coal can be stored from cars, or reloaded from storage at about 2½ cents per ton.

All new mechanical plants should be so designed as to provide

JOINT SMOKE INSPECTION BUREAU OF RAILROADS OPERATING IN CHICAGO						
Date _____ 191__						
Inspector _____						
of _____ R. R. noted following cases of dense smoke emission on above date:						
ROAD	Eng. No.	TIME		DENSITY No.	LOCATION	REMARKS
		From	To			

Postal Card Form for Smoke Inspector's Report

correctly, applicants for these positions pass through a probationary period during which time, under the direction of an experienced inspector, they make thousands of smoke readings with a full size Ringlemann chart set up 50 ft. from them in the direction of the stack under observation. These men are under civil service and their standing is based largely on their ability to correctly read smoke density. The members of the Railroad Smoke Inspectors' Association and the city inspectors frequently have joint classes in the reading of smoke density in order that uniformity may be obtained in the case of independent individual observations.

One of the encouraging features of this plan is that it has so fully met with the approval of the city smoke bureau that the latter has voluntarily opened all their record books to members of the railroad bureau, and the reduction in the per cent of density of railroad smoke during the past two years has been remarkable. It is as follows:

1912.....	10.74 per cent
1913.....	6.06 per cent
*1914.....	7.41 per cent

*The figure for 1914 was made up from the Summer reading of 1914 (by old method) and the reading for September, October and November, 1914 (by new method). This figure would be lower but for the change in method.

DISCUSSION

It was believed that with the special devices now applied to locomotives for the prevention of smoke it was a matter of supervision and constant inspection to obtain smokeless firing. The splendid record made by the railroads in the city of Chicago is evidence of this. If the railroads entering other municipalities

a storage adjunct to permit of unloading coal into the receiving hopper, from which it may be distributed, either to the plant direct, or to a storage pile when business is dull and there is a surplus of road cars and of coal. The plant must be so designed as to permit of the recovery and issuing of the coal from the storage pile through the plant without the use of road cars.

pile, coal is picked up by the crane and discharged into the hopper, from which it is handled to the overhead coal pocket in the usual manner. A special crane of 110 ft. radius is used by this road, the gage of the crane track being 20 ft. A 22,000-ton storage is thus obtained with a 12-ft. depth of pile. The crane uses a 3½-ton bucket and has a working capacity of 150 tons

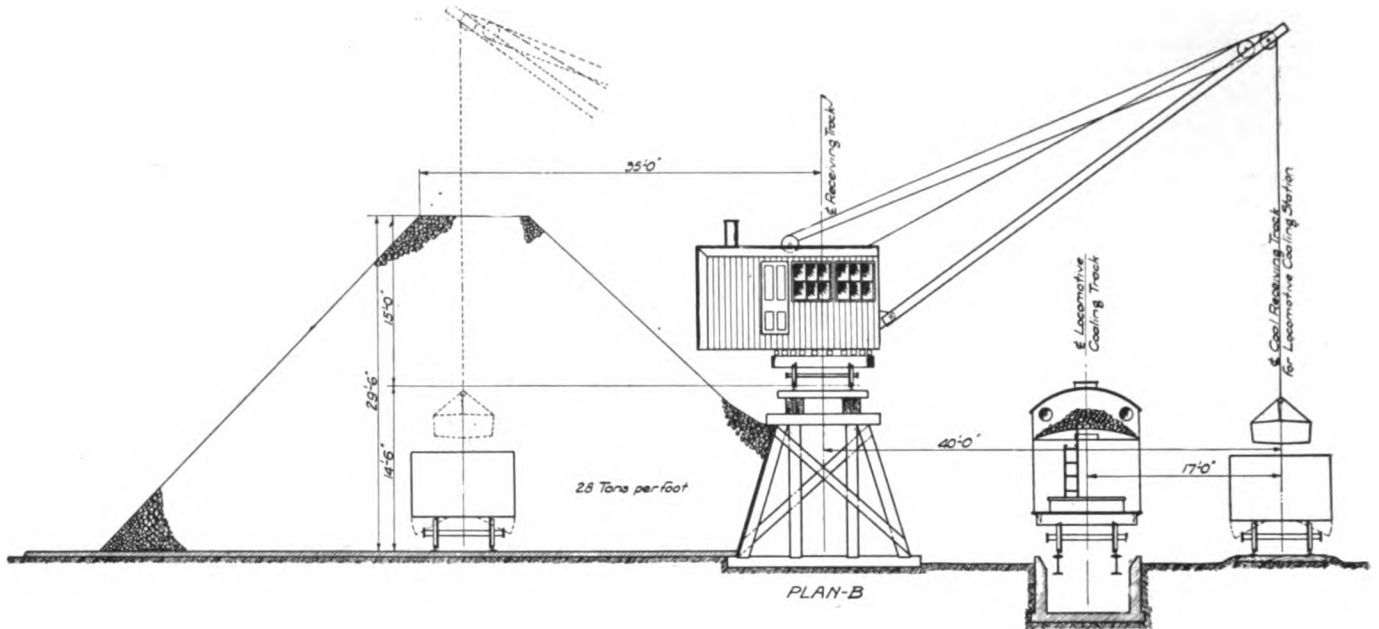

Fig. 1—A Method of Storing Coal at Fuel Stations

The locomotive crane may be used to good advantage for taking care of ground storage in connection with a mechanical coaling station. This plan has been adopted by the Louisville & Nashville, at three places, where large mechanical coaling stations of reinforced concrete and steel construction are being erected. Such a plant is shown in Fig. 2. The receiving hopper is en-

per hour. For the most economical operation, such a crane should be electrically operated. Such a plant is estimated to cost \$23,000 and has a capacity of 22,000 tons.

With the bridge type, the receiving hopper pit is constructed practically the same as for the locomotive crane. This type lends itself to a much larger storage pile and greater handling capacity

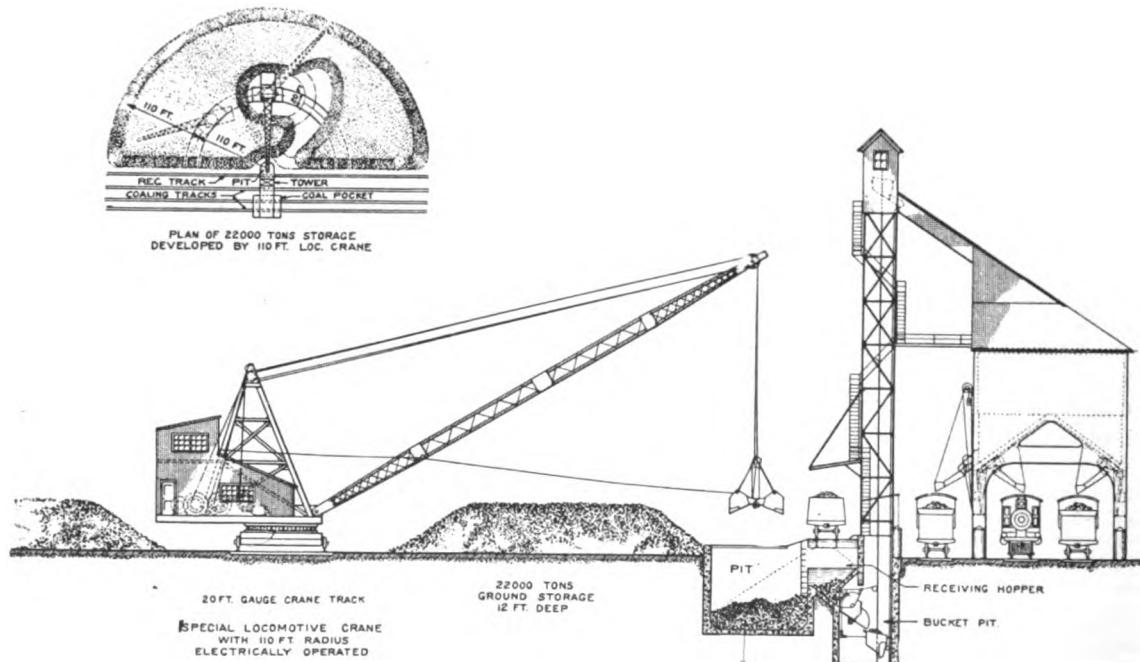

Fig. 2—Method of Storing Coal at Fuel Stations on the Louisville & Nashville

larged at the back to form a pit of sufficient size to accommodate the grab bucket of the crane. The crane is located on a circular track back of this hopper, this track centering on the hopper. Coal is dumped into the hopper from the receiving track, and handled to storage by the crane. In reclaiming from the storage

than the locomotive crane, but it is, of course, more expensive. The inner trucks of the bridge run on a circular track and are held in position by an arm extending to a central swivel point. The outer trucks also travel on a circular track, the center of the circle being the swivel point above referred to. Coal dumped

into the pit at the side of the receiving hopper of the coaling station, is picked up by the grab bucket on the bridge and placed in storage. A swivel bridge of latest design can be contracted for complete above the rails, for from \$25,000 for 100 ft. span, up to \$50,000 for 250 ft. span, and handling from 100 to 300 tons of coal per hour.

The cable and drag scraper method has been adopted by the Southern Railway, the Canadian Northern, and others. It is illustrated in Fig. 3. The storage pile is located directly back of the receiving hopper of the coaling station on a large elliptical area. The coal is dumped into the hopper and conveyed to the top of the coal pocket by the usual mechanical means. Instead, however, of dumping into the coal pocket, the coal is deflected into a chute which carries it out into the storage area. The coal is then spread over this area by means of a drag scraper operated from a drum in a tower over the hopper. Located at intervals around the storage area are pulling poles to which are attached snatch blocks for the endless cable. This method has the advantage of low first cost and low cost of operation, but causes a great degradation to the coal.

The cableway excavator method contemplates having the storage pile between the receiving hopper and the coal pocket, and

storage plants at the Panama Canal as representative of the latest practice, the matter being taken from the annual report of the Isthmian Canal Commission for the year ending June 30, 1914.—EDITOR.]

WEIGHING AND MEASURING DEVICES AT FUEL STATIONS

The committee recognizes the absolute necessity for having correct efficiency performance records of individual locomotives and enginemen, and believes that the railroads and their executives are prepared to spend certain moneys for proper auditing, but that they desire more reliable results and want to know the actual facts as to what their locomotives and enginemen are doing. Fuel accounting should be considered from two separate and distinct standpoints: That of value and that of quantity. The individual coal plant, locomotive and enginemen should be charged with that which it or he receives, and credited with that which it or he issues and uses. No adjustments of any character should be included in the published statements showing individual performances.

It is deemed advisable to suggest the adoption of some reliable automatic means of weighing and measuring, and devices that might be cheaply installed, operated and maintained; not only on new plants being installed, but also that might be applied to

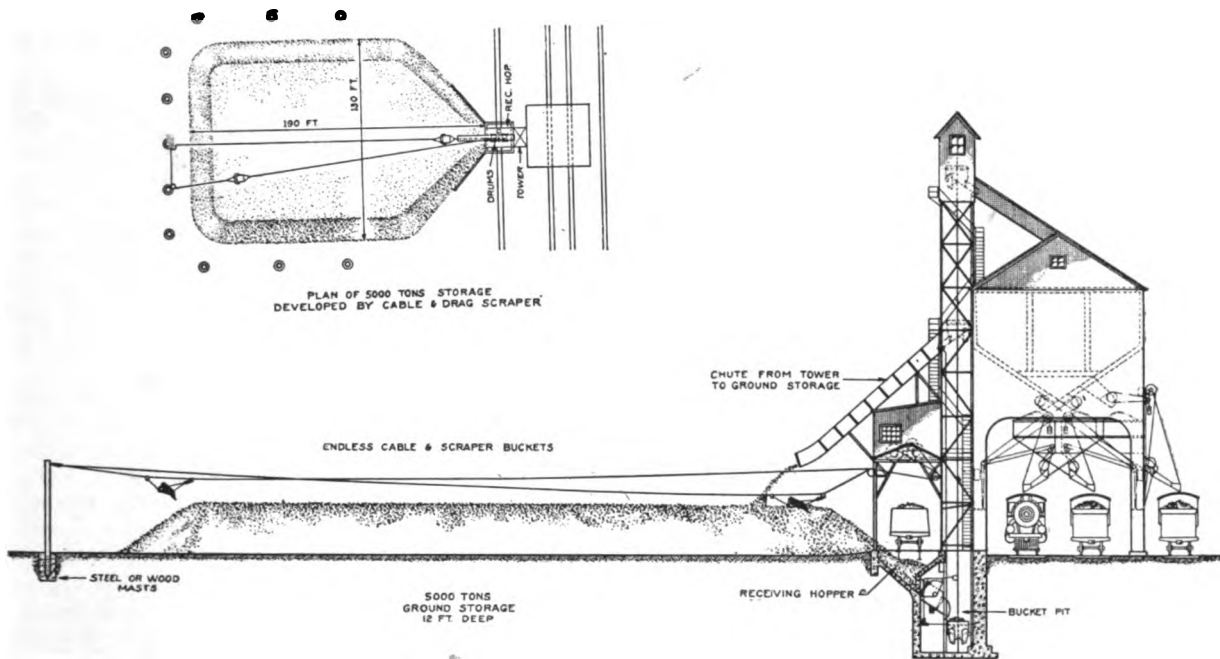

Fig. 3—Cable and Drag Scraper Method of Storing Coal at Coaling Stations

is particularly well adapted to a storage of 2,000 or 3,000 tons. A mast is provided at the coal pocket of sufficient height to enable the drag bucket to dump into the bin. Directly behind the receiving hopper, anchorages are provided for the main cable. The hopper is so constructed that the drag bucket may scrape toward the coal bin over a sloping concrete floor. In reclaiming, the coal is picked up by the drag bucket, and deposited directly into the coal pocket, ready for locomotives. This is a very economical system, and has the advantage of not requiring additional machinery for the coaling station. It also lends itself very readily to "under-water" storage.

A central storage plant should provide for the storage of from 100,000 to 500,000 tons, and each plant should be as elastic as possible. It should be located at some convenient central distributing point. It should be as near permanent in its construction as possible, and be so designed and constructed that it could be protected at all times without much expense for maintenance, operation and care. It is believed that a modern plant, answering all practical purposes, can be installed for 100,000 tons of coal for an outlay of from \$30,000 upward.

[The committee included in its report a description of the coal

plants that are in operation. The committee suggests that this subject be again referred to them, believing that additional methods of establishing an automatic and reliable record of the actual amount of coal issued by each plant to each locomotive and each engineman will be on the market during the coming year.

The report is signed by H. J. Slifer, chairman (Cons. Eng.); E. A. Averill (Standard Stoker Company); E. E. Barrett (Roberts & Schaefer Company); W. E. Dunham (C. & N. W.); H. B. Brown (I. C.); G. W. Freeland (Williams White & Co.); W. L. Krausch (C. B. & Q.); R. A. Ogle (Ogle Construction Company); D. J. Madden (Erie), and J. L. Rippey.

MECHANICAL STOKERS

The mechanical stoker today is practical, operating at a mechanical firing efficiency of 90 per cent or more, and effects operating economies that cannot be otherwise obtained—it is no longer in the experimental stage. Improvements in the design and construction of stokers will no doubt be made for many years to come. Locomotive design will undoubtedly be modified until the stoker becomes a part of the original design instead of being

merely an attachment to the locomotive, as at present. Notwithstanding the necessity for further improvements the fact can no longer be questioned that the mechanical stoker today is an important factor in railroad operation and must be recognized as such by all thoughtful railroad officials.

The real economy of the stoker is in the increased tonnage that can be handled by stoker-fired locomotives—not in the saving of fuel, as seems to be the general impression. The large, mechanically-fired locomotives of today are able to handle more tonnage than the same locomotives would be given if hand-fired, and handle this tonnage at a higher speed and with greater certainty than under hand-firing conditions. The development of the stoker has made possible the development of locomotives designed to burn coal continuously at a rate in excess of the capacity of the ordinary fireman to supply it. The real reason, therefore, for the improvement and adoption of the mechanical stoker is found in the economic necessity of reduced operating costs. The capacity of locomotives already in service may be increased and cheaper grades of fuel may be used on such locomotives, with the locomotive stoker.

According to the most reliable figures obtainable at the present time (April 1, 1915) and not including the experimental stokers, there are at the present time approximately 935 locomotives equipped with stokers on about twenty different lines of railroad.

There seems to be no fixed factor which can be used as a sure guide as to what constitutes a stoker job. One report indicates that any locomotive of 200,000 lb. total engine weight, with cylinders of 22 in. or over should be operated with stoker-firing. A second report states that engines having a tractive effort of 50,000 lb. or over should be stoker-fired. It seems to be the consensus of opinion that locomotives should be hand-fired when the coal consumption for extended periods does not exceed 4,000 lb. per hour.

The consensus of opinion is that the stoker will give about 10 per cent increased tonnage capacity, as compared with hand-firing, under the same conditions as to grade and time. Some believe that the tonnage increase will be more than 10 per cent. It should not be expected that stoker-firing will show any advantage in this respect where the job is within the capacity of a competent fireman. Stoker engines will make better time than hand-fired engines and while doing so will haul more tonnage than can be hauled with engines that are hand-fired.

It has not been the intention in the design of the Crawford stoker to use any cheaper grade of fuel than is used on similar engines that are hand-fired, nor does the Crawford stoker require the use of prepared coal. Both the Hanna Locomotive Stoker Company and the Locomotive Stoker Company state that their stokers will handle cheaper grades of fuel than can be successfully hand-fired, and that their stokers will enable locomotives to use some grades of coal that would be impossible with hand-firing. The Erie's experience does not indicate that a cheaper grade of fuel should be used.

The consensus of opinion seems to be that stoker-firing will not show a saving in the gross amount of fuel used, although there is a slight diversity of opinion on this subject. It is believed that there will be a saving on the basis of the amount of coal burned per thousand ton miles. This is due to the fact that additional tonnage is handled by stoker-fired engines with about the same gross amount of coal as with hand-fired engines. A marked saving is also made by the use of a less expensive quality of fuel.

While the stoker is a factor in increasing locomotive efficiency—that is, while it increases locomotive tonnage capacity to such an extent as to overbalance considerations as to first cost and maintenance costs—it is not a device for saving fuel. The real economy of the stoker is in the increased tonnage that can be handled. This is the meat of the whole stoker proposition. If increased capacity of locomotives is desired, then stokers are economical. If economical evaporation is what is required on

large engines, its attainment may result in a sacrifice of maximum tonnage capacity.

Black smoke can be made with both hand and stoker-firing, or it can be eliminated by careful stoker or hand-firing. Average stoker-firing will probably show less black smoke than average hand-firing, because the coal is delivered to the fire in smaller quantities at a time.

There is less liability of engine failures with stoker-fired engines, owing to the fact that the stoker practically eliminates the necessity of opening the fire-door. Thus a more even temperature is maintained in the firebox, with less liability of leaky flues. In addition to this, if the engine should have leaky flues and bad grates or a bad fire, steam pressure can often be maintained with a stoker, when under hand-firing it would be impossible to keep up steam. Records to date indicate that firebox troubles are less on stoker-fired engines than on hand-fired engines.

The most important phase of the stoker proposition is that the engineer does not have to figure on the stoker tiring out, and is willing to work his engine to its full capacity under all conditions; whereas, under certain conditions with hand-firing, it would not be expected that the fireman could stand up against the largest engines when they were worked to full capacity. It is for this reason that increased tonnage can be handled with a stoker-fired engine, closer meets can be figured on and made, and better general results obtained.

The first cost of stoker installation, giving approximate figures only, is somewhere between \$1,500 and \$1,700. Maintenance costs, including interest on the original investment, are anywhere from ½ cent to 1 cent per mile. Maintenance cost figures at the present time, however, are not particularly reliable on account of the fact that more or less experimental work is being done with these stokers. It is generally stated that stoker maintenance costs do not nullify the saving in fuel cost possible where the stoker uses a cheaper grade of fuel. The only figures that have been presented on the cost of lubricating the stoker show the cost to be about \$1 per 1,000 locomotive miles.

There is no added probability of engine failures which are not stoker failures on stoker-fired engines; and the reverse seems to be the case, on account of reduced liability of boiler failures. The consensus of opinion seems to be that a stoker failure should not imply even a partial engine failure, although the instructions on some roads are that in case of a complete stoker failure, tonnage will be reduced to hand-firing rating. One road reports that a stoker failure means a complete engine failure, on account of the fact that such a low grade of fuel is used on stoker-fired engines that hand-firing cannot be successfully performed with this fuel.

A skilled fireman must be employed on stoker engines, owing to the fact that it is occasionally necessary to resort to hand-firing for short distances, and to the fact that in the case of a partial, or complete stoker failure, hand-firing is necessary. The stoker makes the fireman's job a better one. He makes more money, on account of being able to follow his engine more closely, and a large percentage of the manual labor necessary with hand-firing is eliminated. Any good fireman can easily learn to operate a stoker. A fire which is properly prepared for hand-firing is all right for stoker-firing.

There should be no reason for a failure of the stoker equipment holding an engine beyond the ordinary time required for turning. In fact there are no repair jobs on a stoker that would necessitate delay, providing a proper stock of repair parts is kept on hand and the work handled promptly.

The Pennsylvania record with the Crawford stoker, covering a total of 204,922 trips, including all of the experimental trips during the time the stoker was being developed, shows an efficiency of 83.8 per cent. It can be readily understood that present efficiency is considerably higher than this figure. A six months' record of the use of stokers on the Norfolk & Western shows 97½ per cent efficiency, which makes the statement that the

stoker is over 90 per cent efficient at the present time seem conservative. Roads having a considerable number of stokers in service show a performance of over 50,000 miles per engine failure on stoker-fired locomotives.

It seems conservative to state that the stoker will show a very satisfactory fuel economy based on ton-mile performance. That is, while it may not show a reduction in the gross amount of coal consumed per trip, it will show that it can haul more tonnage than a hand-fired engine, using about the same gross quantity of the same or a cheaper grade of fuel.

From the coal producers' standpoint, the increased demand for slack coal and screenings for stoker-fired engines will no doubt be of benefit.

The stoker permits general operating efficiencies that would be otherwise impossible. Trainloads can be increased by the application of stokers to locomotives where the cost of grade reduction would be prohibitive or where bridge weights or terminal facilities, or both, might prohibit the introduction of heavier and larger power. On districts where train movement is so frequent as to approach the limit of single or double track capacity the increased speed of trains hauled by stoker-fired locomotives, together with the increased tonnage of such trains, will assist in relieving the congested conditions.

The stoker entirely obviates any question of the necessity for two firemen on large engines.

The stoker lives up to its worth, maintaining maximum steam pressure uniformly when the engine is worked at 100 per cent cut-off or at shorter cut-offs and higher speeds. To sum it all up, the stoker, even in its present state of development, pays and pays well in every case where a real stoker job is indicated.

The development of the stoker makes the design of larger locomotives possible and practicable. In fact, locomotives have been purchased within the last two years and are being built today which would neither have been purchased nor built had it been necessary to have them hand-fired. This refers particularly to the very large Santa Fe type, Mallet and Triplex engines.

In closing this report the committee begs leave to call the attention of this association to the fact that the stoker has arrived. It is a success, and, furthermore, it is an absolute necessity from an economical operating standpoint for a great number of the large engines of the present day.

The report is signed by: D. C. Buell (U. P.); W. C. Hayes (Erie); A. N. Willsie (C. B. & Q.); T. R. Cook (Penn.); R. Emerson (S. L. & S. F.); O. L. Lindrew (Ill. Cent.); L. R. Pyle (M. St. P. & S. S. M.); Edw. C. Schmidt (Uni. of Ill.), and C. A. Spaulding (C. & N. W.).

DISCUSSION

It was the general opinion that in the consideration of the locomotive stoker the fuel economy should be considered secondary to the operating advantages this device presents; that is to say, its ability to increase greatly the boiler capacity and thereby permit of greater tonnage to be handled at higher speeds would outweigh the increased amount of fuel that the stoker consumed. In addition to this, a much cheaper grade of fuel can be used successfully than is possible in hand-firing. However, tests comparing the stoker with hand-firing have in some instances shown an increase in evaporation.

E. A. Averill, of the Standard Stoker Company, called attention to comparative tests made on the Pennsylvania division of the New York Central with the Standard stoker. In one set of these tests the conditions were maintained as nearly alike as possible, five hand-fired runs and four stoker-fired runs being made with the same engine, the same engine crew and practically the same tonnage. A poorer grade of fuel, however, was used on the stoker-fired engines, averaging 13,711 B. t. u. for the stoker runs, as against 14,494 B. t. u. for the hand-fired runs.

"These tests," Mr. Averill said, "indicate clearly the following: First, the locomotive when stoker-fired evaporated 7.4 per cent

more water per unit of heat supplied; second, 18.6 per cent more coal of 5.4 per cent lower heat value was burned per square foot of grate area per hour by the stoker, resulting in the generation of 18.8 per cent more steam; third, while the power in the cylinder was increased 20.2 per cent, if gaged by the amount of steam consumed, the amount of dry coal used for the stoker increased but 15.9 per cent, and was 5.4 per cent lower heat value."

Another stoker-fired test of one run was made with an increase in tonnage, which compared with five hand-fired tests, as follows:

	Hand fired	Stoker fired	Per cent difference
Actual tonnage	3,786	4,218	11.2
Adjusted tonnage	3,563	3,995	12.1
Running time, in hours.....	3.74	3.38	10.7
Average speed, miles per hour	16.12	17.8	10.4
Average boiler pressure, lb....	195.3	201	2.9
Total coal fired, pounds.....	18,640	21,000	12.67
Dry coal fired, pounds.....	18,426	20,676	12.2
Dry coal, per hour.....	4,924	6,117	24.2
B. t. u. per pound of coal..	14,494	13,767	5.3
Total water to boiler, pounds..	116,624	137,915	18.3
Steam used in cylinders per hr.	29,734	39,295	35.5
Pounds of water per million			
B. t. u. in dry coal.....	436.8	484.6	11
Cost of coal per million B.			
t. u. in available steam...	.0624	.0575	8.5

These tests indicate: First, the locomotive when stoker-fired, pulled 12.1 per cent greater tonnage at 10.4 per cent greater speed, with an increase of but 12.2 per cent in dry coal, which was of 5.3 per cent lower heat value; second, when stoker-fired the boiler evaporated 11 per cent more water per unit of heat supplied; third, the power as judged by the amount of steam consumed by the cylinders per hour, increased 35.5 per cent, while the dry coal per hour increased but 24.2 per cent and was of 5.3 per cent lower heat value on the stoker-fired run; fourth, the cost of coal per million heat units in available steam was decreased 8.5 per cent by the stoker.

H. B. MacFarland, Sante Fe, stated that he had also found that the stoker engines have shown an increase in evaporation over hand-fired engines.

On the Duluth, Missabe & Northern the stoker engine uses coal that passes through a 2-in. bar screen, the lump not passing through this screen being used for hand-fired engines, thus giving a much better grade of coal for that service. While the fine coal is desirable, it is not impossible to use the larger coal. The Chicago, Indianapolis & Louisville find it expedient to use coal from which the screenings passing through a 4-in. screen have been removed, this being done to accommodate the mine operator. No trouble has been experienced with handling this kind of fuel. Mr. Willsie, however, recommended that screenings pass through a 2-in. round hole screen, which gives the best results. F. Kirby, of the Baltimore & Ohio, stated that a mixture of nut, pea and slack gas coal for stoker engines will give a saving of about 10 per cent over other classes of coal. Trouble has not been experienced when this grade of coal is used for one part of the run and run-of-mine for the next, thus showing the adaptability of the stoker to the various grades. Mr. Kirby believes that better results could be obtained if more attention was given to the draft appliances. On the B. & O. the stoker-fired Mikado engines use from 6 to 6¼-in. nozzles. The 2-10-2 type engines use 6½-in. nozzles, and the Mallet engines used 6¾-in. nozzles.

W. S. Bartholomew, president of the Locomotive Stoker Company, sketched the development of the stoker briefly and stated that this device did not generally find a market until the engines got so large that it was necessary to mechanically fire them in order to obtain their rated boiler capacity. The problem for the stoker manufacturers now is to develop the stoker for the economical use of fuel. Most any kind of coal can be used, and from the mechanical standpoint the stoker is a success. Regarding the use of pulverized fuel, he believed that there was a distinct field for that and the stoker, as the stoker eliminated the necessity of pulverizing the fuel, which must be done at more or less expense, and that many of the advantages claimed for the

pulverized fuel are now being obtained on stoker-fired engines. He also strongly favored the use of the brick arch on stoker locomotives, but pointed to the fact that inasmuch as they presented economies in themselves their acquisition and maintenance should not be charged to the stoker.

The overfeed stoker was criticized to some extent on account of the fact that with the intense draft of the locomotive and the fineness of the coal used, a large amount of the fuel would pass out of the stack unconsumed, thus materially reducing the fuel economy. The smoke question was also believed to be a serious one with the overfeed type of stoker, but the defenders of this device blamed the occurrence of these features to the lack of the proper design of brick arch and improper instructions and supervision to the fireman. Both the smoke and the escape of steam from the pops should be more carefully watched if fuel economy is to be obtained in stoker engines. It has been found that new men are best on the stoker engines, as they can be more properly educated. As with any other device, the stoker must be properly maintained, and the cost of not doing this will be reflected in the fuel performance of the engine.

FUEL OIL FOR LOCOMOTIVE USE

BY G. M. BEAN

Pacific Coast Representative, American Arch Company, Los Angeles, Cal.

From 1907 to 1914 the use of fuel oil by railroads increased 112 per cent, and until a total of 31,000 miles, distributed over 50 railways, was operated with this fuel. A study of the use of fuel oil in the locomotive furnace is extremely interesting.

In the combustion of fuel oil, where the steam spray is used for vaporization, we are confronted with the fact that in the process of atomization we start the particles of oil on their way to the flues, even before they are partly burned. The first result of these particles coming into the heated portion of the furnace is to separate the carbon from the hydrogen, the carbon thus being left as a fine dust floating in the furnace in such a manner as to be easily carried to the flues unconsumed, to be deposited as an insulating layer of soot, or to be carried out of the stack in the form of black smoke. If these fine particles of carbon were attached, as in a bed of coals, a supply of air could easily complete their combustion. With liquid fuel, therefore, the diffusion must be simultaneous with ignition, with the resultant long flame. Large furnace volume is very essential to the burning of fuel oil. While the relative dimensions are of minor import to the volume, it is evident that we must provide a flame passage of sufficient length to prevent unconsumed particles passing to the flues.

There are two distinct types of oil burners, namely, the external atomizer and the internal atomizer. The former has by far the most general use, both in stationary and locomotive practice. The burner of this type used on locomotives consists of a rectangular casting containing two longitudinal passages separated from each other by a horizontal partition. The oil flows through the upper passage to an opening in the face of the burner so arranged that it allows the oil to drool down on to the flat steam jet which issues from a similar but much smaller opening. The steam sprays the oil into fine particles and forces it back to the point of combustion or to the vicinity of the flash wall.

All of the burners use steam at full boiler pressure as the atomization agent. Experiments with the use of air and superheated steam have been conducted, but no results obtained which were considered of sufficient importance to warrant their use. However, the writer believes that further experiments in the use of superheated steam are advisable, in view of the fact that it is extensively used in stationary and marine service.

At the first inception of the idea in this country it was natural that the designs used in Russia were followed. The burner was placed under the rear of the firebox, and directed forward with an upward incline so that the flame shot under a low, short

brick arch, with the result that combustion became so intense in this limited space as to cause the flame to pass from under the arch with such velocity as to impinge on the door sheet, side sheets and crown sheet, with very detrimental results. The back end burner arrangement also required an excessive quantity of fire brick, which not only gave trouble by continually burning out, but also served to cover up valuable heating surface, restrict the furnace volume, and throw an increased load on the remaining heating surface.

The burner is now placed in the front end of the draft pan (Fig. 1), and directed toward the rear in such a manner that the draft is forced to reverse the direction of the flame before it passes to the flues. The furnace is open, the brick work kept low and the maximum of heating surface exposed. The correct drafting of this arrangement is still a somewhat debatable subject, but the general idea seems to favor the admission of the principal volume of air through openings in the vicinity of the flush wall, which is built up under the door, it being the plan to admit this air through numerous small openings, preferably circular in shape, and distributed well over the rear third of the draft pan in such a manner that the air is brought in contact with the flame from several directions and not in too concentrated a volume. A small amount of air is also admitted around or under the burner so as to prevent it from overheating, and keep the flame from dragging on the floor of the pan. This

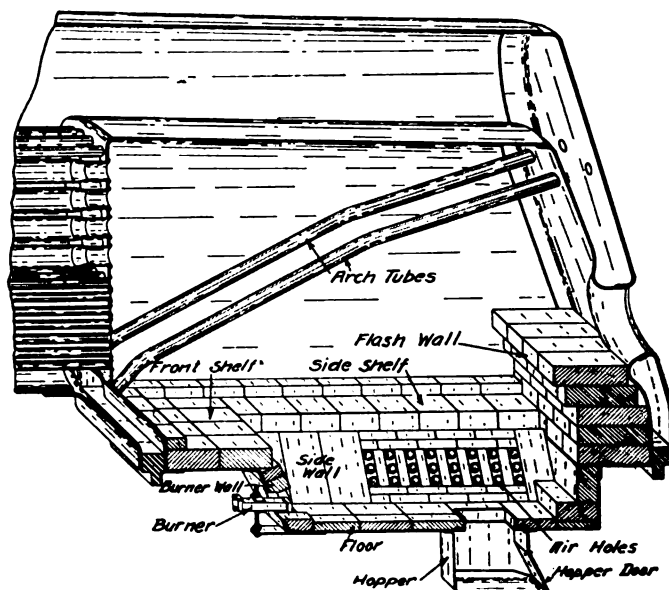

Fig. 1—Front End Burner Furnace, Atchison, Topeka & Santa Fe

arrangement results in a very uniform distribution of heat and the consequent lengthened life of the fireboxes and flues, until now it can safely be said that for service under like conditions, a firebox on a locomotive burning oil will last longer than one in a coal burner if consideration is given to the extra work possible to be obtained from the oil burner. Oil requires from 20 to 30 per cent more air per pound of fuel than the average bituminous coal. There is a tendency to restrict the air openings in draft pans of oil burners, and the writer has found it very generally the rule that with locomotives of the same class in both oil and coal burner service the oil burner will have the smaller nozzle, indicating the necessity for maintaining a higher front end vacuum in order to draw in the necessary amount of air to make the engine steam properly. This is attended with the added difficulty that the high velocity of the entering air produces a more concentrated column or stream which is difficult to break up, requiring a heavy atomizer, the use of which has its disadvantages.

The oil supply is carried in tanks built to fill the coal space of the tender, and piped from there through suitable connec-

tions to the burner. It is generally necessary to provide means for heating the oil so as to insure a proper flow, as gravity is depended upon for the necessary pressure. It is probable that the box heater is the most desirable arrangement, and it will be seen by referring to Fig. 2 that it is indirect in its action, only heats a sufficient volume to insure a supply at the burner, and is not liable to cause trouble by allowing water to get into the oil storage.

Fig. 2 shows in detail the general arrangement of oil burner equipment which represents the latest standard arrangement as applied to locomotives of the Atchison, Topeka & Santa Fe, and is probably as complete and efficient as any so far devised. In an experimental way arches are being applied on the tubes shown and it is anticipated that an improvement in furnace efficiency, life of flues, etc., will be the result. The carrying of arches in this manner has been successfully followed on the New York Central lines for some time, and the practice will undoubtedly be extended throughout all oil-burning equipment.

of heat that overheating will occur if the brick work is not allowed to cool down before the water is removed from the boiler. There is a tendency on account of the ease of operation of the oil-burning engines, to neglect their maintenance. This should be carefully watched and not allowed, as it will not only give a poor performance in oil consumption but cost more than if the engines were properly maintained between the general shoppings.

H. T. Bentley, of the Chicago & North Western, stated that there are 124 oil engines on that road, and he finds that the cost of repairs to them is not more than for the coal burners. When the oil burners get in bad condition it has been found possible to get more life out of the boiler and out of the engine between shoppings by changing them over to coal burners.

The size of the burner should not be too large, the tendency being to have them so. The large 2-10-10-2 Mallet locomotive, No. 3,000, on the Santa Fe, is operated with only one 3-in. burner. The engineer and fireman should co-operate, and the fireman

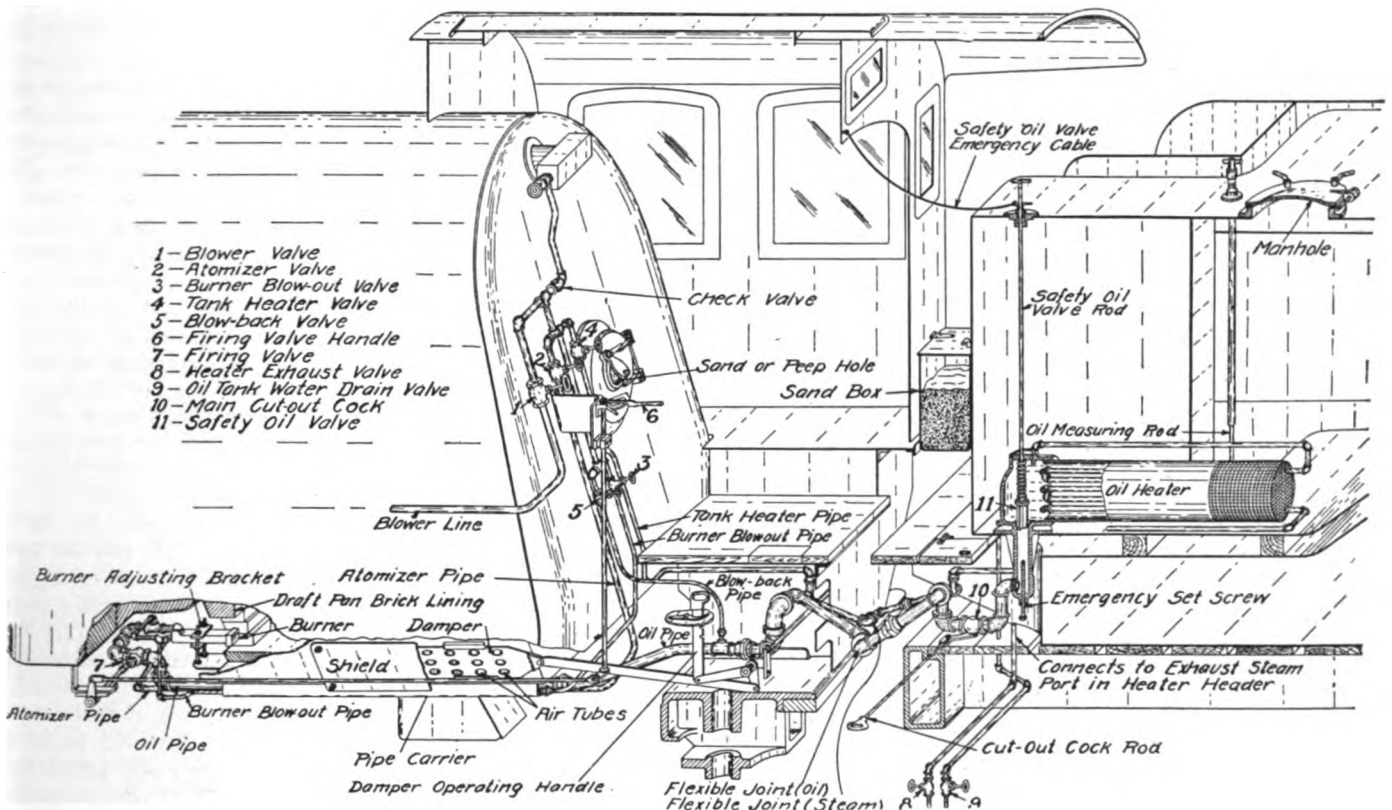

Fig. 2—Standard Arrangement of Oil Burning Apparatus Used on the Atchison, Topeka & Santa Fe

Special attention is called to the necessity for careful supervision of all locomotive equipment and care not to abuse the privilege of having oil burner power to handle trains by overloading at the ultimate expense of the fireboxes and flues. Emphasis should be placed on the fact that the oil fireman is a large factor in the success of the operation of oil-burning locomotives. He must intelligently follow every movement of the engineer that demands regulation of the fire. He has two gages to guide him, the top of the stack and the steam gage. That is, the proper steam pressure must be maintained with the least possible smoke. A thin gray color at the top of the stack is usually indicative of proper combustion.

DISCUSSION

Several members spoke in favor of the brick arch for oil-burning locomotives, as with this device the flame is more equally distributed throughout the firebox and the flues are protected from the cold air. However, the arch must be maintained in good condition and care must be exercised in draining the boilers, as the brick work stores up such a large amount

anticipate the engineer's operation of the throttle with his control of the oil. The success of the oil burner depends upon the fireman, and he should be properly educated and supervised.

FRONT ENDS, GRATES AND ASH PANS

The committee on this subject sent out letters of inquiry to various railroads requesting information concerning the front end, grate and ash pan arrangements.

Front Ends.—Ninety individual arrangements were submitted for non-superheater locomotives, and they show a wide variation in the arrangement of the drafting appliances, there being no well-defined prevalence of any given arrangement, nor a general conforming to the master mechanic's recommendation for the proportioning of the front end. Thirty-eight individual front end arrangements were submitted for superheater locomotives showing the practice on 14 roads. These prints show a general prevalence of arrangement using a short nozzle stand and an inside stack with a wide flare at the base, and a considerable overdraft. During the past one or two years particular attention

has been directed toward the form of the exhaust nozzle. The drafting of locomotives has always been considered a function of the front end alone, but speaking broadly, this is not correct. Drafting may be defined as the controlling factor in combustion of the fuel, and rightly starts at the air openings in the ash pan. With these fixed the grate next governs, and then the firebox volume, tube area and length, the brick arch, etc., all exercise influence over the problem. If these items are right it is not believed that any very delicate adjustment in the smoke box will be needed. There is nothing mysterious about the action of the exhaust jet to induce draft, and if all other factors receive their just due, it is not believed that we would have engines of the same class varying $\frac{1}{2}$ in. in the diameters of their nozzles, with their diaphragms clear down or clear up, etc.

Grates.—Twenty-one railroads responded to the request for design of grates. From a study of the replies it is found that the percentage of air openings of 62 bituminous grates varies between a minimum of 25.8 per cent in one design of interlocking finger grate type and a maximum of 49.6 in a design of the herringbone type, the average of all cases giving a percentage of 37.2 per cent. The degrees of coarseness of the grates have been expressed in terms of the maximum dimensions of any air openings. This figure will vary between the limits of $\frac{1}{2}$ in and $1\frac{1}{2}$ in. The 1 in. dimension of air opening is found to be that most generally used. The character and the degree of fineness of the coal appears to govern the degree of coarseness of the grate to be used. The nature of the coal and the degree of tendency to form a clinkery ash will naturally govern the design in that particular in reference to the width of grate bars or length of the fingers.

Anthracite Grates.—The percentage of air opening for the anthracite grates received varies from 32 per cent to 46.9 per cent, the average being 39.4 per cent. The coarseness of the grate in these cases, as represented by a maximum air opening, is $\frac{3}{8}$ in. in two cases and $\frac{1}{2}$ in. in the other.

Ash Pans.—From the information received it is evident that there is a very great variation in this important point at the present time. The highest percentage of air opening in regard to grate area for bituminous coal is 15.1 per cent, while the least is 5.78 per cent, a difference of 161 per cent. With the tube area taken as a basis of comparison the maximum is 127.1 per cent and the minimum 50.8 per cent, the difference in this case being 150 per cent. The average ash pan air opening for all bituminous burning engines is 11.08 per cent of the grate area and 82.1 per cent of the tube area. Previous investigations have shown that the air openings should total not less than 14 per cent of the grate area for best all around results, and from the information collected it would seem that not less than 110 per cent, instead of 75 per cent, of the tube openings should be used for the air opening in the ash pan. It is difficult to conceive any valid argument either from a theoretical or a practical standpoint against ample air openings under the fire. With restricted areas the velocity of the air must be increased, necessitating high draft throughout the system. Conversely ample areas will allow a reduction in the total draft.

It has been determined that the angle of repose of ash under the conditions encountered in locomotive service is in the vicinity of 53 deg. from the horizontal. The ash pan volume should be made as large as possible, this being a safe rule, as with modern power they can hardly be made too large. On very large power with trailing wheels the use of the six hopper style of pans will often very materially increase the capacity over what might else be obtained. A proper guard against throwing the fire from the ash pan air openings must be provided. It is believed that the best method is that of admitting air for the full length of the mud-ring and protecting the opening by rolling up the outer edge of the top of the ash pan high enough to make it impossible for the emission of fire. When netting or perforated plate guards are used it is difficult to keep them in first class condition, as they must generally be hinged and they are

apt to become warped or bent, making it impossible to close them fire tight. They also cut down the air opening very considerably and cases have been known where they have been painted over so often as to practically stop up the holes, restricting the air flow very seriously.

The report was presented by M. C. M. Hatch, chairman of the committee on Drafting Locomotives.

DISCUSSION

A. G. Kinyon, of the Seaboard Air Line, spoke strongly in favor of the table grate, as it provides a much greater air opening and will better distribute the air through the fire.

Some success has been obtained by the use of the double-exhaust, the Delaware, Lackawanna & Western having made it standard on all their anthracite burning locomotives and are now trying it on the bituminous coal engines. While as a rule success has not been obtained with the variable nozzle, one design was mentioned as being successful. The nozzle has a bridge that may be raised or lowered from the cab, thus regulating the area of the nozzle opening.

OTHER BUSINESS

The committee on Storage of Coal presented a very interesting and instructive report, showing that the storage of coal is desirable from two points of view. It will not only assist the coal operators, which the railroads should be very willing to do, and it is also of advantage to those roads which find it necessary to haul the coal long distances or find it difficult to procure their coal exactly when they want it. By the storage of coal at the proper time the coal carrying equipment will not only be released for carrying revenue coal at the rush periods, but there will also be a much less amount of equipment necessary. A large percentage of the coal carrying equipment now in service on the road is only in active operation for a few months of the year. Thus it is seen that a large amount of capital is tied up in a non-productive state for a very large period of time. Much could be done to relieve this situation if the railroads could be induced to store their coal.

An interesting method of examining storage piles for undue heat was mentioned during the discussion. This may be done by means of an iron rod $2\frac{1}{2}$ in. in diameter, which is worked down to the bottom of the pile and allowed to remain there for 12 hours or more. On withdrawal, if it is too hot the storage pile at that point should receive immediate attention. The critical temperature, as ascertained by those in authority, is believed to be 140 deg. Fahr. In the storage of coal a concrete floor will be found desirable, and care should be taken that there are no pockets in this floor, for they will accumulate moisture. The height of the storage piles will vary according to the characteristics of the coal and the storage ground upon which it is placed. Many instances were mentioned where coal had been stored for 2 to 10 years with no trouble from spontaneous combustion, while new coal would take fire quite readily.

The committees on Fuel Tests and Fuel Accounting submitted reports of progress. Arrangements have been made with the University of Illinois to conduct tests on various classes of fuel, as soon as the necessary contributions can be obtained for conducting this work. The committee on Fuel Accounting reported that it is to seek to reduce the number of forms in order to eliminate the clerical expense of the work. Other papers were presented on Fuel Conditions in South America by James W. Hardy and the Waste of Fuel in Railway Stationary Plants by Jos. W. Hays. Mr. Hays called attention to the very poor conditions found in railway stationary boiler plants and pointed to the large economies that might be made if this matter was given the proper attention. His paper was presented by F. A. Moreland, who showed lantern slides of the actual conditions found in service. The remarks of both these gentlemen were more or less confirmed by S. H. Viall, chief deputy smoke inspector of the city of Chicago, who mentioned a number of instances where the lack of proper maintenance of the boiler

setting and the draft appliances had been costing the railroads a large amount of money. In one case where a steam jet was placed in the stack to improve the draft at an expense of \$10,000 for steam, the boiler setting and draft appliances were corrected for \$5,000. Other items were mentioned of similar extravagance which occurred simply because proper supervision had not been given to this class of work. On the Wabash Railroad the locomotive supervisors have included in their duties the inspection of the stationary plants, and it has been found that they are able to very much improve their conditions by this practice.

A. W. Perley, Oregon-Washington Railroad & Navigation Company, made a very interesting talk on the possibilities the railway employes have in assisting the railways as a whole in the matter of adverse legislation. The following officers were elected for the ensuing year: President, D. C. Buell, Union Pacific; vice-presidents, John G. Crawford, Chicago, Burlington & Quincy; E. W. Pratt, Chicago & North Western; W. A. Averill, Baltimore & Ohio; executive committee, W. C. Hayes, Erie Railroad; H. T. Brown, Illinois Central; M. C. M. Hatch, Delaware, Lackawanna & Western; A. G. Kinyon, Seaboard Air Line, and T. J. Lowe, Canadian Northern. Chicago was chosen as the next place of meeting.

The secretary-treasurer reported a total membership of 680 and a cash balance of \$826.62; 316 members registered during the convention.

THE MECHANICAL SIDE OF RAIL-ROADING*

BY WILLIAM SCHLAFGE
General Mechanical Superintendent, Erie Railroad

If we are to analyze railroad operation it is obvious that we will find that each department has problems and troubles peculiar to itself. On the mechanical side the great problem, as to American railroads, is the care, inspection and maintenance of 2,500,000 freight cars, 56,000 passenger train cars and 66,000 locomotives, representing an investment estimated at three billion three hundred and fifty million dollars and calling for an annual maintenance charge estimated at \$450,000,000. It is not possible, nor even desirable, perhaps, to go into the details of mechanical operation to show the magnitude of the work involved; but a faint conception of it can be had by recalling that approximately one billion passengers and over one billion tons of revenue freight are carried per annum on American railroads. Carrying units must be kept in condition to transport this great volume of business in safety, to conserve both life and property, and locomotives must be maintained in condition to move it.

To meet the complex responsibilities of the mechanical side of railroad operation and maintain the equipment in a state of preparedness demands, as in every other department of the business, a balanced and efficient organization, whose members shall be devoted to the work and sustained by the animated pursuit of a common purpose. The usual staff organization of the mechanical department consists of a chief officer, styled superintendent or general superintendent of motive power, mechanical or general mechanical superintendent, superintendent of machinery, or other title appropriate to the office. On the larger roads the chief mechanical officer, as a rule, is assisted by one or more deputies, bearing various titles, who have general authority and, sometimes, have direct supervision over the shops, thus standing between the shop organizations and the chief of the department. Not infrequently there is an officer charged with responsibility for the work of the car department, with the title of superintendent of car department, or master car builder. On the Erie Railroad there are three mechanical superintendents. One has general charge of all car work of the system, and one is as-

signed to each grand division of the road in direct charge of the locomotive shops and has concurrent jurisdiction, in a restricted sense, over car work in his territory. The other regular staff officers are a mechanical engineer, electrical engineer, engineer of tests, chemist, chief boiler inspector and general inspectors of various grades and diverse duties. The larger roads add to these two general officers who are indispensable where there is any pretense of practicing the higher phases of railroad economy, using that term in its scientific sense. These are an efficiency engineer, who is in charge of shop costs and production and frequently is at the head of the piece work system, and an expert in locomotive economy, whose duty it is to save fuel and look after the economical operation of the locomotive. On the Erie these officers are designated, respectively, as superintendent of piece work and apprentices, and superintendent of locomotive operation.

The chief officer of the shop organization is the division master mechanic, or shop superintendent, on the locomotive side and a shop superintendent, foreman of car repairs, or an officer having some similar suitable title, at the car shops. The division master mechanic frequently has charge of all mechanical work on his division; but it is customary to have large car shops entirely independent of his authority. The shop organization varies with the size and importance of the shop. At a large shop there are usually a general foreman, an assistant to the general foreman who is in charge of shop costs and production, departmental foreman, inspectors, etc.

In the division mechanical organization special mention should be made of the engine terminal which, by reason of its functions, is not properly classified with shop operations, whether closely associated with them or not. Nothing will paralyze traffic movement and demoralize operation quite as effectively as putting an engine terminal out of business, or to have it in charge of a man who is incapable of facing all emergencies and overcoming everything but the physically impossible. This is so well understood that we are accustomed to say that engine house foremen, like poets, are born, not made.

Associated with the divisional organization are the road foremen of engines and the inspectors of locomotive service, called supervisors of locomotive operation on the Erie. The mechanical department has concurrent jurisdiction with the transportation department over these officers.

A strong organization is essential to good operation; but there are limits to what may be done by the best organization and the most devoted and diligent application on the part of the personnel. A good organization may overcome, in a measure, the handicap of inferior, inadequate or obsolete shop and engine house facilities, but it can never supply their lack.

The mechanical side of railroading produces no income, sends no actual cash into the treasury regardless of what it may keep from going out. Its mission is to do its part to keep cars and locomotives in shape to earn revenue. Each passenger locomotive may earn approximately \$3,700, and each freight locomotive \$52,000 per annum, but the sad truth ever confronts the mechanical man, that from 20 to 25 per cent of all operating expenses is laid up against him. He is a good spender and he is always "broke." His stories, therefore, are apt to be of the hard luck variety. The mechanical man makes up a modest program for a new roundhouse at one point; two or three modern coal and ash handling plants; a couple of new power plants; perhaps a new shop; a hundred new machines and a job lot of fifty thousand dollars' worth of small tools and miscellaneous things regarded as useful in his business. When the hard pressed management makes a few minor revisions of his plans he cheerfully accepts the allowance, builds an extension to several stalls of the old roundhouse to house the big engines, puts new flues in the boilers of the much slandered power plants, gives the old shop a coat of whitewash inside, forgets the rest and, like a true railroad man, settles down to do business with what he has, as better men have done before him and will do after he has gone. After all,

*From a paper read before the Railroad Men's Improvement Society, New York, November 19, 1914.

he reasons, there is something to be thankful for. If something had to be cut off, far better the improvements than his head.

An ancient institution that has given way to enlightenment is the old railroad apprentice system. In the old days, the average apprentice who served his time in a railroad shop learned to operate the various machines and to repair locomotives, but he was rarely an all around mechanic. Little, if any, attention was given to his educational qualifications when he was apprenticed and, unless he had the ambition to attend night school or apply himself to study, he usually lacked that knowledge of the principles of mechanics and of higher mathematics which would fit him to extend his field of usefulness. Also the master was not particular, at all times, to concern himself about giving the novice the best opportunity to become a good all around journeyman. If the apprentice had special aptitude for certain work he was too frequently kept at it, instead of moving him about to afford a wider range of training. Moreover, certain details, like valve setting, air pump, lubricator, injector and tool room work were regarded somewhat in the light of trade secrets and the apprentice was fortunate who got any experience in or knowledge of this work. Progressive thinkers finally came to the realization that the system was all wrong and that it was not beneficial to the master, the apprentice or to society, and out of these conclusions has grown a system of railroad apprenticeship and industrial education of the highest type.

Speaking of the apprentice course of the Erie as typical, I can say that the railroad apprentice today has every opportunity to become a well rounded mechanic, and is given a basic technical education that equips him for the widest usefulness. In most cases the instructors are college graduates. Contrary to the practice under the old system, the apprentice is now carefully and fully instructed in the very things that, formerly, were withheld from him, and extreme care is taken to make him proficient in every detail of the art. Not only is the course free but the apprentice is paid for his time while under instruction.

But I would not have you get the impression that I am speaking as a mechanical man. Rather would I have you think of me as a railroad man. I have scant tolerance for departmental distinctions. Departmental lines are very proper, and necessary to fix the lines of responsibility and for the orderly and effective conduct of business; but no further. It is trite to say that all energies that are not directed toward the ultimate and legitimate ends of any business, are wasted or at least impaired. That end in the railroad business is to sell transportation at a decent profit, and everything which diverts energy, that the business is taxed to create, from that object is a thing to be weeded out. Those who accustom themselves to see departmental work in capital letters, failing to co-ordinate their relations with the general interests of the business, are in danger of acquiring a wrong perspective. We all preach about co-operation, but constructive evidence of its practice does not equal the noise we make about it. The word co-operation, like efficiency and other mouth-filling terms, is rattled about like a pebble in a tin can. Many know what constructive team work is, a few practice it, but the majority merely talk about it and look wise.

INSPECTION OF LOCOMOTIVES AND TENDERS

At a meeting of mechanical representatives from over 50 roads with the Conference Committee of Mechanical Officers of the Special Committee on Relations of Railway Operation to Legislation, held at Chicago on May 24 and 25, the following rules were formulated for the inspection of locomotives and tenders. They were distributed to the railroads by the Special Committee as Bulletin No. 68, with the recommendation that they be filed by each railroad subject to the act, with the chief inspector of locomotive boilers at Washington, D. C., on or before June 4, 1915, and that in addition each road file at the same

time its standard practice or practices with regard to tire thickness as contemplated under Rule No. 2.

RULES FOR THE INSPECTION OF LOCOMOTIVES AND TENDERS

1. Locomotives and tenders after arrival shall be inspected to determine that machinery and running gear is in safe condition. All repairs essential to safety shall be made before locomotive is returned to service. Locomotives with following defects will not be allowed to leave terminals where repairs can be made:
2. Wheels which do not conform to the limit of tread and flange wear recommended by the American Railway Master Mechanics' and Master Car Builders' Associations shall be removed or handled in accordance with the standard practice of each railroad involved, except as follows:
3. Steel wheels and steel tires with following defects will not be allowed to remain in service:
 - (a) Tread worn hollow $\frac{3}{8}$ in. in depth;
 - (b) Slid-flat or shelled out spots 3 in. long on driving tires.
4. Springs which will not carry the respective load when engine is standing, must be replaced.
5. Lateral motion at journal boxes shall be corrected when it becomes sufficient to cause serious interference between wheels and other parts of the locomotive.
6. Locomotives shall not be run with excessive lost motion between engine and tender.
7. Locomotives equipped with auxiliary couplings between engine and tender must have such couplings maintained in serviceable condition.
8. Locomotive tenders shall not be run with excessive clearances between rear side bearings.
9. In order that the engineman shall have sufficient illumination ahead of the engine to allow him to readily perform his duties while operating in and out of passenger terminals and industrial sidings, while switching in yard, and to readily locate whistle posts, yard limit and crossing signs and such other land marks en route, a headlight on a road locomotive shall not at any time during service have apparent beam candle-power less than the following; the readings to be made in a vertical plane 25 ft. ahead of the focal center and referred to points at various stations in the reference plane:

READINGS AT CENTER OF REFERENCE PLANE

Reading point ahead of focal center	Apparent beam candle-power
500 ft.	Not less than 450 cp.
600 ft.	Not less than 490 cp.
700 ft.	Not less than 500 cp.
800 ft.	Not less than 500 cp.
900 ft.	Not less than 500 cp.
1,000 ft.	Not less than 500 cp.

AVERAGE SIDE READINGS (AVERAGE OF READINGS TAKEN AT EACH STATION 20 FT. EACH SIDE OF THE CENTER)

Reading points ahead of focal center	Apparent beam candle-power
50 ft.	Not less than 30 cp.
100 ft.	Not less than 110 cp.
200 ft.	Not less than 225 cp.
300 ft.	Not less than 315 cp.
400 ft.	Not less than 350 cp.

The above readings are to be considered independent of the location of the headlight, the source and intensity of light, the design of the reflector, etc.

In connection therewith, the Conference Committee of Mechanical Officers made the following statement:

"Our committee entrusted with the filing of rules is very much at a loss as to what the law really covers. On its face the law is to promote safety of employees and travelers on railroads by compelling common carriers, etc. The boilers which admittedly involve safety questions are already covered, and the same is true of ash pans and safety appliances. This leaves the machinery and tenders, which are inspected partly for safety and partly for economic reasons, not involving safety at all, and consequently not covered by this law.

"When all is said there are comparatively few defects which involve the question of safety, viz.: wheels, tires, springs, side bearings, and possibly one or two minor matters. Such matters as lateral play in boxes, condition of shoes and wedges, crossheads, and rod bushings, are not questions of safety, but purely economic ones in which the owner only is concerned."

HIGH-VELOCITY STEAM PIPING.—The advantages of small, high-velocity steam piping are lower first cost for pipe, valves and covering, etc., less erecting and maintenance cost; loss less weight; less radiation loss; less chance for water to accumulate and less difficulty with valves of smaller size.—*Power.*

RAILWAY STOREKEEPERS' CONVENTION

A Digest of the Reports and Papers Presented at the Twelfth Annual Meeting, Held in Chicago

The twelfth annual convention of the Railway Storekeepers' Association was held at the Hotel Sherman, Chicago, May 17-20. The association was welcomed to the city by Mayor Wm. H. Thompson. J. H. Waterman, superintendent of timber preservation, Chicago, Burlington & Quincy, replied to Mayor Thompson, and an address was made by E. D. Sewall, vice-president, Chicago, Milwaukee & St. Paul.

G. G. Allen, general storekeeper of the Chicago, Milwaukee & St. Paul and president of the association, said in his address that the association had prospered during the past year, 105 new members having been added, 20 of whom were from roads not previously represented. Referring to storekeeping practices, he emphasized the value of well-equipped storehouses in promoting economy, and advocated the employment of supply cars on roads whose location and physical condition lent themselves to such a practice.

The secretary-treasurer reported a total membership of 823, and \$546 cash on hand.

SCRAP AND SCRAP CLASSIFICATION

The real meaning of the word scrap is not fully understood by the average railroad employee. To most people scrap implies something useless, without value and to be disposed of only by being cast away. The fact that an article has been cast off does not imply in any way that it is without value for some other purpose. The economical handling of scrap in all of its phases is one of the most important items in railroad operation.

The cost of handling scrap should be considered carefully, as duplicate handling is very expensive. There are some kinds of scrap having such small market value that, if handled through one or two operations at scrap yards or on line of road, the actual cost of handling is greater than the amount realized from the sale of the scrap. On the other hand, with certain kinds of scrap one handling or operation, such as sorting out pieces of certain size or length, or cutting a few bolts and rivets, will result in a saving of several dollars per ton when the scrap is placed on the market.

Scrap should be picked up by section gangs daily and assembled at points designated, such as tool houses, etc. After it is assembled at these points it should be loaded at intervals suitable to conditions.

In loading scrap, rails and frogs should be loaded separately from track scrap, if possible. Mechanical scrap picked up off the right of way and in yards should be loaded separately; serviceable roadway material should be separated and transferred from time to time, instead of ordering new material.

Mechanical scrap should be forwarded to the nearest mechanical shops or supply yard for reclaiming. After reclaimed material has been removed, the car should be loaded to capacity with other scrap and forwarded to the place designated as a general scrap or supply yard, for making ready for the market.

In the handling of scrap, important features to consider are the equipment and back haul. The selection of equipment should be made from cars used for rough freight handling; consideration should also be given to the loading of scrap in open or closed cars to suit conditions at the general supply or scrap yard.

Another feature that should be followed up very closely is the loading of equipment to full tonnage. Oftentimes scrap is forwarded long distances with light load, whereas it could be started out with a light load and all scrap picked up until reaching general headquarters, by which time, if properly handled, the car would have its full tonnage.

Special care should be given to the switching of cars in

and around scrap yards with a view of curtailing unnecessary switching. It is necessary that cars loaded ready for weighing be pulled out at certain intervals in order to save switching and as many cars as possible should be handled at this particular time, with the understanding, of course, that other cars will be set immediately for reloading. Scrap should not be loaded in foreign cars unless this is absolutely necessary, and in case it is loaded in foreign cars, the scrap yard foreman should give these preference in order to release the cars promptly.

[The committee suggested the special preparation of certain specified items of scrap not covered in the scrap specification, in order to obtain a better price, the understanding being that this will not change the present scrap classification.]

The report is signed by W. Davidson (chairman), Ill. Cent.; W. A. Linn, C. M. & St. P.; A. L. Tucker, C. & N. W.; H. E. Rouse, C. G. W.; J. F. Rothschild, C. B. & Q.; F. A. Bushnell, G. N., and H. Scatchard, N. & W.

Discussion.—Several members did not approve the addition of a classification for miscellaneous mixed scrap; others believed it necessary in order to provide for small roads without means of classifying and preparing scrap. Reference to the separation of high speed steel scrap brought out the fact that most roads do not have any to sell, a great many welding the small pieces on soft steel and thus using them up. Several members were of the opinion that scrap should be sold direct to the consumer and that the scrap dealer be eliminated. It was decided not to adopt the mixed and miscellaneous scrap classification.

RECLAMATION OF MATERIAL

An abstract of the report of the Committee on Reclamation of Material, as well as a description of the Great Northern plant, will be found in the Shop Practice Section of this issue.

ACCOUNTING FOR SECOND HAND SERVICEABLE MATERIAL

By C. H. SAMSON

Assistant Auditor, Chicago, Burlington & Quincy, Chicago, Ill.

With full appreciation of the highly important part it takes in the purchase of material, there is yet reason to believe that in nothing does a store department render greater service to the company it serves than in judicious and persistent efforts to avoid purchases.

Storekeeping is many-sided and only by developing all sides in their just relation and proportions to each other will the store department as a whole take and maintain its proper place in the railroad organization. Its primary object is to secure the most economical care and use of material and in that work, accounting, in its usual acceptation, though secondary and complementary, has an important part in that it puts the results of the care and use into record form, which is of value in proportion as it truly reflects the physical conditions and transactions.

Accounting for released material is somewhat different from other phases of material accounting in that it can be absolutely controlled in both the debit and credit, as the values are essentially arbitrary. The main consideration under such conditions is the use of values that will best harmonize with the values fixed by purchase and will be the most natural to apply. The commercial theory and practice in the handling of second hand material cannot be properly applied to railroad accounting as the railroad is its own best customer and there is neither profit nor sense in "robbing Peter to pay Paul," which is prac-

tically the case when one account or department is allowed to take advantage of another.

Material returned to store stock is naturally divisible into three classes for which fixed bases of value can be established:

1. Usable in its present form; value, same as corresponding new material.

2. Needing repairs to make it usable; value, a fixed percentage of corresponding new material when released and full value when repaired.

3. Scrap, not fit for use or repairable; value, fixed prices according to kind.

Considering these classes in the order named, as the physical condition of released material, whether salvage or unused, fixes the class to which it should belong, it is entirely practicable for store department men to determine when an article is usable and to account for it at its proper value, without any supplementary description of its condition, as the fact that it is issued for use is evidence enough. On the other hand, if usable second hand material is handled on a percentage basis, more or less distortion of the material account will surely follow. When received, any desired percentage can be readily applied, as there is no question then as to the fact that it is second hand, but in the issue the distinction must be made on the appearance of the article, and often by the average man under working conditions. However appealing the method may be in theory, and it looks good, in practice it is both unsafe and unnecessary.

As material in stock is issued at its stock value, regardless of the current market price, so should uniformity in value of second hand material be maintained, regardless of its particular use, with only such self-descriptive exceptions as are expedient on account of values and accounts involved, and they are surprisingly few.

As material needing repairs becomes usable when repaired, it naturally follows that its value, when released, should be the usable, or new value, less a percentage allowed for repairs. Before it is repaired, it is not available for issue and therefore cannot be charged to the material class from which the repaired article will be issued. The two conditions can be satisfactorily met by charging the released value and cost of repairs to a material class designated as scrap and crediting that class at usable value, as scrap can readily absorb, in its adjustment, all differences caused by the varying cost of repairs. The greater part of scrap ordinarily is sold, so that the actual value is determined by the market, but so far as the accounting is concerned the values can and should be fixed, subject to adjustment when the sales are made.

In the three sub-divisions, released material touches many phases of storekeeping and for its efficient handling and accounting demands the closest co-operation in the physical and accounting work. An effective working plan, therefore, must not only meet the various complications with definite rules, but must have rules that fit the working conditions at the physical end.

RECOMMENDED PRACTICE

The committee, instead of presenting additional recommendations, feels that it is desirable at this time to call attention to the recommended practices already made by the association. Correspondence with about 50 railroads, relative to the recommended practice, shows that on the whole great improvement in the economical handling of material could be made, provided many recommended practices as outlined by the association were actually put in use by the different roads.

Due to the different methods of handling and accounting, it is impossible at the present time to make a proper comparison of the efficiency of the stores department on the various roads. The greatest fault is with the storekeepers themselves, in not forcefully bringing these practices to the attention of their own roads, and calling attention to concealed expenses in handling material.

To properly compare the work of the stores department, we must have a common basis of arriving at the store expense, and a system of accounting which will not conceal or wrongly distribute the cost of handling material. It would appear that under the present rules of the Interstate Commerce Commission the cost of handling at least could be compared, but such is not the case. Store expense on many roads covers only the storekeepers' pay roll, practically all other expenses being charged to operating accounts. Many storekeepers do not do their own accounting. Storekeepers who actually do all the work that they should do and handle their organization properly are put in a false light by other storekeepers who only do part of the work and are only charged with a portion of the cost of handling and accounting for material.

It should be the duty of the auditing department to see that all the expenses of handling and accounting for material, no matter by what department performed, is charged to the proper account.

Attention was called to the report presented at the convention of 1914 by the accounting committee, and a paper in connection therewith; and the report of the committee on the book of rules, presented at the same convention. These two reports are so complete that the committee recommends that the association urge each member to submit them to their respective roads for adoption. The following in particular appears to be absolutely necessary to the efficient and economical handling of store department work:

The general storekeeper should have entire charge of all material belonging to the company, which is not actually in use, regardless of location. All unapplied material, new, second-hand or scrap, should be carried in his accounts and under his jurisdiction.

The accounting for all material in stock, necessary charges and distributions, including the making of vouchers, should be handled by the storekeeper and charged to store expense.

In order to arrive at honest comparisons, all labor expenses by other departments in handling materials should be charged to the proper account—Material Store Expense. This will do more than anything else in placing the store department on a proper foundation.

The handling of scrap material and the sorting and reclamation of it is not properly a material store expense item and each department should stand the labor cost of the initial delivery to the store department. All labor expended by the store department in unloading, sorting, preparing for sale and loading should be charged to the value of the scrap as carried in the scrap class or account. The cost of reclamation should be charged to the article reclaimed as far as possible by the use of reclamation orders.

A classified statement of material received, issued and on hand should be made so that proper attention could be given to the different classes of material.

Disbursements should include only material actually used or disposed of; transfers between stores are not disbursements; labor in maintenance or construction of equipment should be excluded from material disbursements; material in course of manufacture, including labor expended, should be included as material stocks; temporary tracks and material suspense in connection with them should be excluded.

The importance of store delivery is not understood or appreciated on many of our railroads; consequently, it is not in general use.

While a majority of railroads operate supply cars, the greatest efficiency as regards their usefulness has not been reached. On many roads this car or cars simply distribute oil and a few light supplies. The supply car or train is the connecting link between the storehouse and the user of the material on the road, and should be the one great factor in properly handling and delivering on the ground all material, tools and stationery required for all departments and at the same time pick up all

scrap and surplus material and bring it to the storehouse.

The report is signed by D. D. Cain (chairman), S. A. L.; A. M. Gage, L. E. & W.; Clarence Foster, N. Y. C.; L. O. Genest, C. P.; J. J. Opheim, G. N.; W. A. Miller, Southern; H. C. Cook, S. P.; J. R. Mulroy, Pullman Company, and H. S. Burr, Erie.

PIECE WORK

Previous papers and committee reports have fully outlined the advantages to be derived from the piece work system; have shown how to install and maintain the system; provided forms for records, and have also given a few concrete examples of economies which can be effected. There has seemed lacking, however, information as to the compilation and phraseology of the schedules, and this feature the committee has endeavored to cover in this report on a limited scale.

In making up a piece work schedule it should first be properly classified. The scrap dock employees would not be interested in schedules for handling lumber, nor does the ice house force care anything about schedules for handling rail and track material; hence it is recommended that the schedule be compiled in sections so that each shop or yard can be furnished that portion of the schedule which affects the work it has in hand.

It is not expected that the classification given will suit all cases, but should be modified to cover conditions as they exist in each individual case. The classification of the schedule is as follows:

Concrete products—manufacturing and handling; ice; lumber, switch ties, piling, poles and posts; miscellaneous storehouse material; rail and track material; scrap and reclamation material; signal material; tools and machinery; track ties and tie treating chemicals.

Schedules under the various classified headings should be arranged in numerical and alphabetical order. The heading "Miscellaneous Storehouse Material" may be sub-divided to suit conditions. One alphabetical index should cover the complete schedule.

[Examples were included in the report showing the method used in preparing the schedules.]

The following instructions should constitute a preface to each copy of the schedule.

All work unless otherwise specified is to be done by hand. Derrick prices and machine work includes all work, fixing tackle and machinery and doing the necessary switching, as well as transferring from previous jobs unless otherwise specified.

Loading includes getting material from the storage place, placing in the car, and properly blocking it for shipment unless otherwise specified.

Unloading includes taking from the car to the storage place, inspecting, taking out culls and properly piling or placing in racks or bins, unless otherwise specified.

Prices per "job" or per "trip" for derrick or hand work are to be paid only when it requires the extra switching or trips for the work. They are not to be paid when it does not require extra switching or trip and when the work can be done in connection with other work.

Rubble car prices include all handling of car to and from work, unless otherwise specified.

The report is signed by W. W. Eldridge (chairman), C. B. & Q.; B. W. Griffith, N. Y. C.; Geo. Holmes, M. C.; W. H. Thorn, C. St. P. M. & O.; F. J. McMahon, N. Y. C.; J. A. Stewart, N. Y. O. & W., and W. E. Brownell, Lack. Steel Company.

Discussion.—It developed that only a few roads were using piece work in the stores department, but that these few are well satisfied with the results which are being obtained. The Chicago & North Western finds a considerable increase in the work accom-

plished, and no neglect of inspection. More supervision is needed with piece work. Rates should not be cut when a man's earnings increase.

ACCOUNTING—MATERIAL STORE EXPENSES

In recommending rules governing the accounting for material store expenses, the committee sets forth the principal and general expenses which are concerned and connected with store department operations. In the purchasing department, material store expenses are chargeable with the pay of general and local purchasing officers and their assistants and employees of the purchasing department; also, their traveling, office and other expenses incurred in purchasing material and supplies. The two exceptions are amounts expended for purchasing stationery, which are chargeable to stationery store expenses; and pay and expenses of officers and employees engaged in purchasing a single class of material or supplies, such as ties or fuel, which are chargeable directly to the cost of that particular class of material or supplies.

[Similar analyses of the charges against material store expenses are given for storekeeping, inspection, switching service, motive power and car departments, maintenance of way department, construction department, handling supplies for, and products from company industries, handling rail and ties, handling ice, handling bridge material, signal material, structural steel, etc., which is shipped direct to the jobs, handling scrap, and accounting.]

In the application and distribution of material store expenses, percentage rates, representing material store expenses, should be assessed according to the issues. The percentage should remain in effect until conditions may warrant a change, which may be made monthly or otherwise during the fiscal year.

Material store expenses are chargeable on the value of material issued for construction and additions and betterments, as well as for operating expenses; they are not chargeable in connection with transfers of material and supplies as between stores and stock accounts.

Material store expenses are chargeable on the value of the gross issues from stock, regardless of the value of scrap and second hand material released and received in exchange; they are chargeable on the value of the material issued, to the shops for the manufacture of goods on store department orders and are also chargeable on the value of all shop manufactured goods issued from store stocks. Material store expenses should be assessed on the value of material and supplies sold from store department stocks.

A ledger account entitled Material Store Expenses should be established, for the specific and exclusive purpose of providing a suspense account through which to clear all debits and credits appertaining to the operation of the store department. This account should be credited with the amounts accruing from the application of the percentage for material store expenses to the value of goods issued. The balance in the account, if debit, would represent undistributed expenses due to the prescribed percentages being insufficient to clear the account; if credit, due to the prescribed percentage being greater than the percentages that would have cleared the account.

The account should be cleared in June account of each year by using for the prescribed percentages the rates of per cents that the actual expenses bear to the actual total material issues for the month.

Stationery store expenses should be handled separately from, but similarly to material store expenses.

The report is signed by P. J. Shaughnessy (chairman), Erie; E. L. Fries, U. P.; H. H. Laughton, Southern; E. E. McCracken, B. & L. E.; D. A. Williams, B. & O.; Chas. I. Davis, D. L. & W., and J. W. Camp, B. & M.

Discussion.—The discussion centered largely on the charging of expenses for the handling of scrap. In this respect the report

conflicted with the reports of the committees on Recommended Practices and Reclaiming Material, and was finally amended to agree with them.

STATIONERY

The weak spot in the handling of the stationery supplies by the stores department is that the buying may then be done by a purchasing agent removed from the stores, and much unnecessary correspondence and referring of questions back and forth is entailed.

The strong points in favor of the handling of stationery by the stores department are: An organization for the handling of supplies and material, ordering, receiving, storing, distributing and accounting for. The receiving clerk or clerks of this organization can receive stationery at less additional cost than can a department created for that purpose alone; the porters who handle general supplies can handle stationery supplies at less additional cost than can porters who are maintained for that purpose alone; the distributing force which distributes general supplies can distribute stationery supplies in addition to general supplies at less cost than a force maintained for that purpose alone; the accountants who handle accounts for general supplies can handle the additional accounts for stationery at less cost than can accountants maintained for that purpose alone. All of these men having wider general training than would men handling stationery only, should do the work better.

The conclusions arrived at are:

1. That the handling of the stationery should be done in connection with the general stores.

2. That stationery should be charged out in detail, the same as other material and supplies.

3. That while the receiving, accounting and shipping facilities of the stores be made use of in the handling of stationery supplies, the stationery should be a department by itself within the stores, to the extent that the stationer devote his whole time to stationery matters, and that he be the stationery buyer. In no case should the general storekeeper be called on to do all the buying of stationery.

The stationery organization should be a part of the regular store organization under the general storekeeper, the staff to consist of the stationer, stenographer and stock room man, with the necessary help to handle the stock, according to the size of the road. Requisitions for purchase of stock supplies should be made up by the stock man. The requisitions should then be checked by the stationer and finally should be approved by the general storekeeper for purchase.

The stationery stock room should be of ample size and laid out in sections; a section to accommodate the forms belonging to each department, and a miscellaneous section to care for forms and supplies common to all departments. There should be a catalog of stationery made up in cheap form, so that it could be renewed at small expense, and a copy of this catalog placed in each office. The catalog should be made up to correspond to the stock room.

Each department should have its own series of numbers and symbols. Thus, the motive power department would be given 1 to 200, and its forms would bear its number and letter, thus—F. 160 M.P. Miscellaneous should have its own number and letter M. Each section should be marked with a small sign, as "Motive Power 1 to 200," and the pigeon holes, or shelves, numbered for the forms placed in them. In addition to the shelving for forms there should be, of course, a sufficient number of cupboards and drawers to hold the other material and supplies. The one thing absolutely necessary about a storeroom is that it be big enough.

The report is signed by E. J. McVeigh (chairman), G. T.; C. H. Rost, C. R. I. & P.; R. C. Crosby, Wabash; O. T. Burleigh, B. R. & P.; N. C. Foss, Ann Arbor, and R. A. Weston, N. Y., N. H. & H.

SUBSTITUTES FOR EXPENSIVE LUMBER

BY W. H. CLIFTON

Lumber Agent, Baltimore & Ohio, Baltimore, Md.

As in other lines of industry, there are certain practices which are followed in the use of lumber in railroad shop and building work today, which have been unchanged for many years, regardless of the decrease in the supply and increase in the cost of the lumber used, or the fact that other kinds of lumber, equally well adapted to the purpose, are more easily and cheaply obtained. This condition seems to be due largely to a lack of knowledge of the characteristics of materials other than the ones which have always been used for certain purposes.

There are many occasions when 1 in. by 12 in. by 16 ft. white pine of good grade is ordered when 1 in. by 8 in. by 12 ft. to 16 ft. yellow pine cypress, spruce or even hemlock of a lower grade would answer equally well for the purpose, and would cost considerably less. White pine for pattern work is frequently ordered to be 12 in. and over in width, when, if ordered 8 in. and over with a limit on the percentage of widths under 12 in. acceptable, the lumber would cost less, and the widths under 12 in. will usually be found, piece for piece, to be of better quality than the wide stock.

Not very long ago, while passing through a cabinet shop in a railroad mill, I observed a large number of boxes or trays of a peculiar design in the course of manufacture. The boxes were being made from clear yellow poplar and were heavily ironed, and, I think, were mounted on small truck wheels. Upon inquiry, I was informed that they were to be used as tool boxes by machinists and car repair men for keeping together their wrenches and tools, and for moving them from one job to another. Now, when those trays were finished, they were beautiful to look upon, the bright yellow of the heart poplar standing out in contrast to the black iron branches, but the first time a car man threw his 18 in. wrench or his iron jack lever against the side or end of one of those boxes, an abrasion would appear in the soft surface of the wood in which one might lay a finger, and in a very short time the body and partitions of the box would be gone. Yellow pine or oak would have been a more durable material, and would have cost approximately 50 per cent less than the poplar, but the force in that shop knew little about yellow pine, except that it was more difficult to work, being harder in texture, and I believe, they considered oak too heavy; but they did know poplar and white pine and no doubt figured that, if it was good enough for cab panels and coach siding, it was good enough for the tool boxes.

The storekeeper did not use those tool boxes, but he supplied the stock to make them, and, perhaps, accepted the boxes in his stock and issued them. He is interested to the extent that, when the practice of using such expensive material for ordinary purposes is discontinued, he will have to carry less of it in stock and his stock balance will drop proportionately.

Noting, about a year ago, that a certain shop was ordering very frequently 1 in. by 16 ft. No. 2 white pine barn boards, inquiry was made as to the purpose for which they were used. Among other things, it was learned that quite a large quantity of the boards were being ripped to 2 in. and 3 in. strips and shipped out on the line for staying explosives in shipments and for stripping powder cars. Hemlock and chestnut cut to the desired size is now being purchased for this use at a cost of \$18 to \$20 per thousand feet. The white pine cost \$27 to \$32 per thousand feet. Old car siding and other waste material is also being used.

On two occasions, at different shops, it has been found that track shims were being made from new white oak purchased for gondola flooring, and, while it must be admitted that the shims were excellent and the size of the flooring was well adapted to the method of manufacture, little progress was being made toward economy, which would have been possible

by cutting up odds and ends and obsolete sizes of material, of which there was a considerable quantity available at both shops.

The cases mentioned are not exceptions, and are not peculiar to any one shop or railroad. Similar cases can, no doubt, be found to exist on many roads. The condition is the result of practices in effect when high grade lumber was cheap and plentiful.

A remedy is not hard to find or difficult to administer. Usually a little educating of the consuming forces in the possibilities of substituting, with a view of economy, brings the desired result, for the average mechanic on a railroad is not averse to saving money for the company if some one will show him how to do it and co-operate with him in accomplishing the desired result.

Some of the railroads have already gone quite extensively into the substitution of cheaper and more plentiful lumber. The Chicago, Milwaukee & St. Paul has found Douglas fir of suitable grades at a price ranging from \$26 to \$30 per thousand feet, and Washington cedar at \$30 to \$37 per thousand feet, to be excellent substitutes in many cases for soft yellow poplar at \$65 to \$90 per thousand feet. Both fir and cedar can be obtained in any width and thickness desired and can be satisfactorily kiln dried. While this company still uses yellow poplar for outside siding and interior finish on passenger cars, it has been able to cut the consumption of poplar to about 35 per cent of the quantity formerly used. It has also been found that clear red birch is an excellent substitute for mahogany for seat arms, etc., and at a considerable saving in cost.

The Baltimore & Ohio has very recently taken up the question of substituting red or gulf cypress for purposes for which soft yellow poplar has been used. For all purposes in which substitution has been made it answers equally as well as poplar, and, in some cases, it is superior to poplar for the purpose.

The following comparison of the approximate prices of first and second clear soft yellow poplar and the same grade of red or gulf cypress will give some idea of the saving which will be effected:

APPROXIMATE PRICES, F. O. B. CARS, CINCINNATI, OHIO		APPROXIMATE PRICES, F. O. B. CARS, CINCINNATI, OHIO	
First and Second Clear Soft Yellow Poplar		First and Second Clear Red or Gulf Cypress	
Thickness	Price	Thickness	Price
1 in.	\$50.00	1 in.	\$43.00
1 1/4 in.	55.00	1 1/4 in.	43.50
1 1/2 in.	52.50	1 1/2 in.	43.00
2 in.	55.00	2 in.	46.00
2 1/2 in.	60.00	2 1/2 in.	56.50
3 in.	65.00	3 in.	57.50
4 in.	68.00	4 in.	62.50

The specifications of the Baltimore & Ohio call for poplar 7 in. and over in width and 8 ft. to 16 ft. long; shipments must average 12 in. or over in width and 50 per cent of the boards must be 16 ft. long; only 10 per cent of 8 ft. and 10 ft. boards are admitted. The cypress can be purchased the same way.

It was formerly the practice on this road to use poplar for blocking in between the framing of baggage, mail and express cars to provide a soft absorbent surface to which glue is applied in putting on the outside sheathing. After a trial, it was found that a sound wormy grade of chestnut, kiln dried, could be used for this purpose with as good results as obtained from poplar. The chestnut cost approximately \$20 per thousand feet; the poplar cost \$55 per thousand feet.

Of course, steel is rapidly taking the place of lumber in car and locomotive work, and the possibilities of substitutions of cheaper woods in that class of work will grow constantly less, but there is on most railroads still a large amount of wooden equipment, which will be rebuilt and kept in service for years to come.

The committee on the Uniform Grading and Inspection of Lumber, of which J. H. Waterman, C. B. & Q., is chairman, presented a brief report outlining the action taken during the year. The chairman stated that very little could be reported owing to

a series of disappointments. Various conferences with lumber manufacturers' associations which it was hoped would lead to a better understanding between the railroads and the manufacturers as to specifications, etc., did not take place. These conferences were cancelled or postponed through no fault of the committee.

In a brief address, in which he referred particularly to the paper by W. H. Clifton on Substitutes for Expensive Lumber, A. E. Manchester, superintendent of motive power of the Chicago, Milwaukee & St. Paul, told of cars in service for 35 years on his road equipped with siding and roofing of high grade white pine, the wood still being in perfect condition. He also mentioned a building which has recently been wrecked, the lumber costing at the time the building was erected, 50 years ago, nine dollars per thousand feet. After the building was wrecked this lumber was sold for \$27 per thousand feet.

J. H. Waterman, superintendent of timber preservation, Chicago, Burlington & Quincy, condemned the practice of accepting rejected lumber for any use whatever.

G. G. Yeomans told of at one time accepting rejected lumber on the Burlington at lower prices until 50 per cent. of the contents of the yard was culls. Several purchasing agents stated that there was no trouble in getting good lumber if the poor quality lumber is refused and the shipper compelled to pay the freight both ways. About 15 of the railways represented at the convention refuse to accept rejected lumber at any price. A member told of receiving a number of draft timbers, some of which were 10 ft. 3 in. long and some 12 ft. long. The shorter timbers were all satisfactory while about 50 per cent. of the 12 ft. timbers were culls, the ends being in such a condition that the timbers had to be cut down to 10 ft. 3 in. The result of this practice was that the storekeeper was overstocked with 10 ft. 3 in. draft timbers, while there was a shortage in 12 ft. timbers.

HANDLING SIGNAL MATERIAL

C. R. Ahrens, storekeeper, Delaware, Lackawanna & Western, Hoboken, N. J., presented a paper on the above subject, of which the following is an abstract:

All railroads do not handle signals and repair parts through their stores department. It happens to be the case on the Lackawanna and I believe the practice has been completely successful, both in keeping signal stock down to a minimum and in getting material to the place wanted at the right time, not only for repairs, but on new installations as well. This requires the greatest care and vigilance on the part of the storekeeper in charge of signal material; first, in order to meet the views of the management of the road; second, in regard to the needs of the signal department, in not delaying its work by failing to have material on the ground when wanted.

When a practical man cannot be secured for receiving clerk it will be found helpful on items of signal material, either for stock or direct shipment, to number each item ordered and request the signal companies furnishing them to show on their shipping notices the parts which apply on each item ordered; for instance, if a cylinder complete for a switch movement is shipped to us in three parts each part on the shipping notice is marked "Item 16" or whatever number the cylinder was numbered on our requisition.

We have a signal machine shop in the same building as our storehouse and all relays, mechanisms and such items returned to us for credit or repairs are turned over to this shop and, after they are looked over and repaired, we take them back and allow credit for the value, provided the signal department advises that the repaired material can be used in place of new. All classes of signal scrap are shipped to the division storehouse on each division, except worn out battery elements, for which we have a special place prepared.

R. D. Long, C. B. & Q., also presented a paper on this subject, in which he stated that the signal supply storekeeper should be

a practical signal man. An untrained man in this position can waste much material while a trained man can save much, particularly by reworking and using second hand material. A change in signals on this road made obsolete a considerable amount of material such as relays, etc. These were changed so that they could be made use of, and a considerable saving resulted. This could not have been accomplished without a signal man being in charge of the stores for this branch of the work.

MARKING OF COUPLERS AND PARTS

The committee communicated with all the leading coupler manufacturers of the country and, while their suggestions were of some value, the members came to the conclusion, after tabulating various makes and styles of couplers and repair parts which are manufactured at the present time, that it would be better to number all parts, rather than to number a coupler and use a prefixed letter or letters to designate the parts. The committee therefore recommended the assigning of a series of numbers to each make of coupler and parts; the appointment of a standing committee to take care of assigning additional numbers as required; the publication of a booklet listing the various parts with the assigned numbers; and insistence, on the part of purchasing agents, on having manufacturers show, in raised figures wherever possible, the number applying to any particular part on the body of such part.

The committee submitted a list of such couplers and parts as it has been able to gather and has assigned numbers which it feels will give the desired results.

The report is signed by A. J. Kroha (chairman), C. M. & St. P., and L. H. Tutwiler, B. & O.

Discussion: The chairman of the committee stated that the manufacturers believe that all the information there is room for is now placed on couplers and parts, but he also stated his belief that if the association insists that the recommended numbers be placed on the couplers and parts, the manufacturers will agree to it. The report was adopted and referred to the American Railway Association for its action.

STANDARDIZATION OF TINWARE

W. F. Jones, New York Central, the chairman of the committee on the Standardization of Tinware, stated that the committee had no printed reports but that the previous recommendations were still in the hands of a committee of the Master Mechanics' Association and the report was expected at the June convention in Atlantic City. The members of the association were referred to the issues of the *Daily Railway Age Gazette*, published at the Master Mechanics' and Master Car Builders' Association conventions at Atlantic City, for information as to the action of the Master Mechanics' Association.

BOOK OF STANDARD RULES

The report of the committee on the book of standard rules consisted of an index for the book of rules which was adopted at the 1914 convention.

OTHER BUSINESS

J. H. Waterman, superintendent of timber preservation of the Chicago, Burlington & Quincy, presented a paper entitled "Butting In," in which he stated that the storekeeper had been made the "goat" for other departments long enough. Mr. Waterman considered that the storekeeper should "butt in" to the extent of examining critically all requisitions and substituting cheaper material if it was just as satisfactory.

The following officers were elected for the ensuing year: J. G. Stuart, general storekeeper, Chicago, Burlington & Quincy, Chicago, president; W. A. Summerhays, general storekeeper, Illinois Central, Chicago, first vice-president; H. S. Burr, general storekeeper, Erie Railroad, New York, second vice-president, and J. P. Murphy, general storekeeper, New York Central, Collinwood, Ohio, secretary-treasurer.

LENGTH OF RADIUS BAR FOR TWO-WHEEL TRUCKS

BY L. R. POMEROY

The function of leading or trailing trucks of locomotives should be to prevent the adjacent driving wheel flanges from grinding against the rail, and to compel the flange of the driving wheels to, in some measure, stand away from the outside rail in the case of leading drivers and the inside rail for rear drivers. The grinding action of the truck is proportional to the amount of such force that is exerted. This grinding action is practically nil if the radius bar pin is located at the geometrical or so-called "normal" point, as found by the graphic method or the usual formulas.

In order that the desired amount of guiding action may be effective, the "normal" length of the radius bar must be shortened sufficiently to exert enough stress to cause the truck to apparently enter the curve a certain per cent in advance of the position the truck would assume in relation to the curve, were the pin located at the "normal" point. The various percentages of the "normal" length, as shown by the tables presented, illustrates how design-

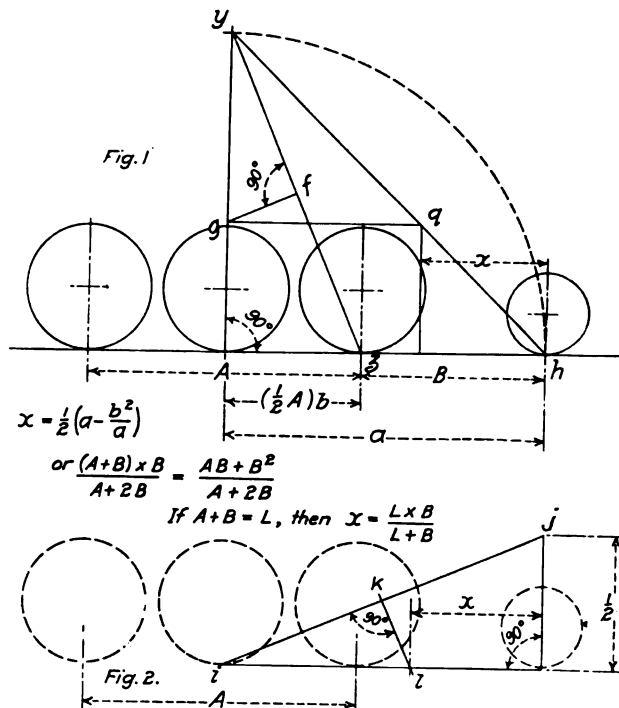

Graphic Methods of Locating Radius Bar Pins

ers differ as to the amount of reduction in length necessary. Out of 20 locomotives, taken at random, the length for trailer trucks averages 90 per cent, and for 14 locomotives with two wheel leading trucks the average is 95 per cent.

There is some particular location of the radius bar pin where the wear between the flanges of the adjacent driving wheels and the truck wheels is balanced or neutralized; this should be the ideal location. Tests made on the Delaware, Lackawanna & Western some years ago with a Mogul type locomotive furnished with an adjustable radius bar, illustrated the foregoing points very clearly. When the radius bar was too short the truck wheels showed excessive flange wear and the leading drivers comparatively slight wear. The reverse was clearly shown when the radius bar was too long or at the "normal" point. By this "cut-and-try" method it was found that if from 85 to 90 per cent of the "normal" length was chosen, very satisfactory results were obtained.

The writer has no record of similar tests with trailer trucks, but it would seem that such a test would be desirable, as the

trailer truck is "pulled" instead of "pushed" around the curve, and therefore the conditions are somewhat different.

Figs. 1 and 2 represent graphical solutions of the geometric location of the radius bar pin for two-wheel leading and trailing trucks. Fig. 1 represents the method used by the Grant Locomotive Works and furnished by the late Prof. J. G. A. Meyer, and is described as follows:

With a radius equal to one-half the driving wheel base, plus the distance from the center line of the forward driver to the center line of the truck wheel *h*, locate the point *y*, making the line *Ay* perpendicular to the base line; connect *yh*, and *yz*. Midway on the line *yz*, draw a line perpendicular to line *yz*, as at *f*; where the line *fg*, intersects the vertical line *Ay* draw a horizontal line to the right, meeting the line *yh*, at *q*; the hori-

lined in the description of the graphical methods of Figs. 1. and 2:

$$(a) \ x = \frac{1}{2} \left(\frac{a - b^2}{a} \right) \quad (b) \ \frac{(A + B) \times B}{A + 2B} = \frac{AB + B^2}{A + 2B}$$

By making $L = A + B$ the formula becomes easier to use, $L \times B$

for then we have $x = \frac{L \times B}{L + B}$. The letters of the formulas refer

to Fig. 1.

MACHINE TOOL EXPORTS.—The exports of metal-working machinery for January, 1915, reached a total of \$2,903,740, nearly \$500,000 in excess of those for December. Over January, 1914, the increase is approximately \$2,000,000. In January, 1915, 935

TWO-WHEEL TRUCKS

Builder	Locomotive, type	Trailing				Leading				Actual length, inches	Road
		Radius bar or box	Per cent	Length by formula, inches	Length, actual, inches	Radius bar or box	Per cent	Length by formula, inches			
Baldwin	2-10-2	Bar	95	87	83	Bar	83	88.4	73.5	B. & O.	
Baldwin	2-10-2	Bar	97	84.5	81	Bar	96	86	82.5	C. B. & Q.	
Baldwin	2-10-2	Bar	97	65.0	63	Bar	79	84	66.0	A. T. & S. F.	
Baldwin	2-6-6-2	Bar	97	74.0	72	Bar	82.5	78	69.0	C. B. & Q.	
Am. Loc. Co.	2-6-6-2	Bar	110	60	66	Bar	75.0	71	63.0	B. & A.	
Am. Loc. Co.	4-8-2	Bar	92	88	81	Mo. Pac.	
Am. Loc. Co.	4-8-2	Bar	86	84	72	C. & O.	
Baldwin	4-8-2	Bar	86	83	71	G. N.	
Baldwin	2-8-2	Bar	99	83	82.5	Bar	77	84	76.5	B. & O.	
Baldwin	2-8-2	Bar	104	83	86	Bar	94	79.5	74.5	G. N.	
Baldwin	2-8-2	Bar	97	87	84	Bar	95	77.5	73.5	C. G. W.	
Baldwin	2-8-2	Bar	100	82.5	82.5	Bar	95	79.4	75.5	B. & O.	
Baldwin	2-8-2	Bar	86.5	83.5	72	Bar	85	80	67.4	Erie	
Baldwin	2-8-2	Bar	96.5	87	84	Bar	92.5	78	72	I. C.	
Baldwin	2-8-2	Bar	95	82.5	78	Bar	94	85	79	C. B. & Q.	
Am. Loc. Co.	2-8-2	Rad. Box	88	82	72	Bar	89	81	72	C. & O.	
Am. Loc. Co.	2-8-2	Rad. Box	89	81	72	Bar	84	81	68	D. L. & W.	
Am. Loc. Co.	2-8-2	Rad. Bar	85	81	69	Bar	80	85	67.5	C. R. I. & P.	
Am. Loc. Co.	2-8-2	Rad. Box	85	81.2	69	Bar	87	80	69.5	Mo. Pac.	
Am. Loc. Co.	2-8-2	Rad. Bar	97.2	71	69	Bar	100	69.5	70	N. Y. C.	
Am. Loc. Co.	2-8-0	Rad. Bar	Bar	98.5	71	70	N. Y. C.	
Am. Loc. Co.	2-8-0	Rad. Bar	Bar	71	79	66	C. & N. W.	
U. P.	2-8-0	Rad. Bar	Bar	93	67½	73	U. P.	
Baldwin	2-8-0	Bar	98	79½	78	L. & N. E.	
C. M. & St. P.	2-8-2	Box	Bar	84	80	67	C. M. & St. P.	
P. R. R.	2-8-2	Bar	Bar	86	78½	67¾	Penn.	
Am. Loc. Co.	4-6-2	Bar	92	85	78	No. 50,000	
Am. Loc. Co.	4-6-2	Bar	86	80.5	69	D. L. & W.	
Am. Loc. Co.	4-6-2	Bar	85	81	69	C. & N. W.	
Am. Loc. Co.	4-6-2	Bar	89.5	87	78	D. L. & W.	
Am. Loc. Co.	4-6-2	Bar	87.6	89	78	Penn.	
Am. Loc. Co.	4-6-2	Bar	85	81	69	Vandalia	
Am. Loc. Co.	4-6-2	Bar	86½	90	78	N. Y. C.	
Baldwin	4-6-2	Bar	93	75	69¾	G. N.	
Baldwin	4-6-2	Bar	94	75	71	G. N.	
Baldwin	4-6-2	Bar	97	80	78	D. & R. G.	
Baldwin	4-6-2	Bar	85	81	69	N. Y. N. H. & H.	
Baldwin	4-6-2	Bar	86	80	69	N. Y. N. H. & H.	
Baldwin	4-6-2	Bar	100	82.5	82.5	B. & O.	
Baldwin	4-6-2	Bar	98	84	82.5	A. T. & S. F.	
Baldwin	4-6-2	Bar	85	85	72	C. & A.	
FOREIGN											
P. L. & M.	2-8-2	Rad. Box	90	84	75	Bar	100	85	85	...	
P. L. & M.	4-6-2	Rad. Box	89	85	75	
Bav. State	4-6-2	Rad. Box	...	94	
Gt. W. (Eng.)	4-6-2	Rad. Box	87	70.5	61½	
Gt. W. (Eng.)	2-6-4	Box	100	59	59	...	
L. T. & S. (Eng.)	4-4-2	Rad. Box	104	60	63½	
Cent. Swiss	2-6-0	Bar	96	73.5	71	...	
Austrian State	2-6-0	Box	94	69½	65	...	
L. B. & S. C.	2-6-0	Box	98	73	72	...	
Italian State	2-6-0	Box	100	60	60	...	
Gt. W. (Eng.)	2-6-0	Box	87	70½	61½	...	
L. B. & S. C.	4-4-2	Box	107	67½	72¾	
L. & S. W.	0-4-2	Box	100	61.2	61.2	

zontal distance from the vertical line at *q* and the center line through the center of the truck wheel equals, *X* the distance sought.

Fig. 2 is a graphic method used in England and was furnished the writer some years ago by the late William Ennis, when the latter was connected with the Rogers Locomotive Works. Draw a vertical line through the center of the engine truck axle and make this line equal in length to one-half the driving wheel base. From the center of the driving wheel base, *i*, draw a diagonal, meeting the vertical line through the center of the truck axle at *j*. Bisect this diagonal *ij* and draw the line *kl*, perpendicular to *ij*. Where the line *kl* meets the base line determines the length of the radius bar *X*, as in Fig. 1.

The following formulas will produce the same results as out-

commercial automobiles, valued at \$2,545,527, were exported.—*American Machinist*.

COAL FOR COKE.—In the last five years the coal used in metallurgical coke manufacture has averaged around 65,577,000 tons, yielding 43,983,000 tons of coke valued at \$111,736,000. Of this total, 14,767,000 tons were used in byproduct coke ovens, yielding, besides the coke 54,491,000 cubic feet of gas, 94,306,000 gallons of tar, and \$9,190,000 worth of ammonia. When it is considered that every year approximately four times these enormous totals of byproducts are absolutely wasted through the use of non-byproduct ovens, the vital importance to the country of a general use of the modern, scientific byproduct ovens will be appreciated.—*Journal of the Franklin Institute*.

EXAMPLES OF RECENT LOCOMOTIVES OF THE MALLET, SANTA FE AND CONSOLIDATION TYPES

ARRANGED IN ORDER OF TOTAL WEIGHT

Type	2-8-8-2	2-10-10-2	2-8-8-0	0-8-8-0	2-8-8-2	2-6-6-2	2-6-6-0	0-6-6-0	2-10-2	2-10-2	2-8-0	2-8-0	2-8-0	2-8-0
Name of road	Virginian	Santa Fe	B. & O.	B. & O.	Virginian	N. & W.	D. & S. L.	N. Y. C.	B. & O.	C. B. & Q.	W. & L. E.	W. M.	K. & M.	M. & O.
Builder	Amer.	Amer.	Amer.	Amer.	Amer.	Amer.	Amer.	Amer.	Baldwin	Baldwin	Amer.	Amer.	Amer.	Amer.
When built	1912	1911	1912	1911	1914	1912	1913	1913	1914	1914	1913	1914	1914	1914
Tractive effort, lb.	115,000	111,600	105,000	105,000	80,000	72,800	76,400	77,800	83,000	84,500	55,900	62,500	50,400	44,370
Weight, total, lb.	540,000	616,000	468,500	468,500	429,000	405,000	359,000	348,000	407,700	406,000	266,500	244,500	239,500	220,000
Weight on drivers, lb.	479,200	550,000	468,500	468,500	355,500	337,300	331,500	348,000	327,250	336,800	236,000	217,500	209,500	191,500
Weight on leading truck, lb.	24,500	22,700	27,500	24,350	22,700	30,500	27,000	30,000	28,500
Weight on trailing truck, lb.	20,000	45,000	56,000	46,500
Weight of tender, loaded, lb.	212,000	234,000	181,500	181,500	169,300	158,000	160,500	157,500	178,600	178,000	177,300	179,500	154,000	151,000
Wheel base, driving, ft. & in.	15-6	19-9	15-0	15-0	10-6	10-0	10-0	10-0	22-0	21-0	17-0	16-8	17-3	16-6
Wheel base, total engine, ft. & in.	57-4	66-5	40-8	40-8	49-10	48-10	39-1	30-8	41-3	40-3	27-0	26-2	26-5	25-1
Wheel base, engine and tender, ft. & in.	91-5 3/16	108-1 3/8	77-2 3/4	77-2 3/4	81-5 3/4	79-3 3/4	72-9	65-8	77-4 1/2	76-6	62-3	68-0	58-2 3/4	61-6 7/8
Diameter of drivers, in.	56	57	56	56	57	56	55	55	63	58	57	51	57	63
Cylinders, number	6	6	4	4	4	4	4	4	2	2	2	2	2	2
Cylinders, diameter, in.	28 & 38	28 & 38	26 & 41	26 & 41	22 & 35	21 & 33 1/2	21 1/2 & 34	21 1/2 & 34	30	30	26	25	25	24
Cylinders, stroke, in.	32	32	32	32	32	32	32	32	32	32	30	30	30	30
Valve gear, type	Wals.	Wals.	Wals.	Wals.	Wals.	Wals.	Wals.	Wals.	Baker	Wals.	Wals.	Baker	Wals.	Wals.
Steam pressure, lb.	225	200	210	210	200	200	225	220	200	200	185	200	180	190
Boiler, type	E. W. T.	E. W. T.	Conical	Conical	Straight	Straight	Conical	Straight	Conical	Straight	E. W. T.	Straight	E. W. T.	Straight
Boiler, smallest outside diameter, in.	79	101 1/2	89 3/4	89 3/4	83 3/4	83 3/4	84	83 13/16	90	90	83 9/16	83 3/4	80	76 9/16
Tubes, number and diameter in inches	377-2 1/4	377-2 1/4	334-2 1/4	334-2 1/4	260-2 1/4	235-2 1/4	272-2 1/4	272-2 1/4	262-2 1/4	269-2 1/4	293-2 1/4	239-2 1/4	266-2 1/4	220-2 1/4
Flues, number and diameter in inches	48-5 1/2	48-5 1/2	38-5 1/2	38-5 1/2	36-5 1/2	36-5 1/2	36-5 1/2	40-5 1/2	48-5 1/2	48-5 1/2	43-5 1/2	36-5 1/2	36-5 1/2	32-5 1/2
Length of tubes and flues, ft. & in.	16-5	24-0	24-0	24-0	24-0	24-0	20-6	20-0	24-0	23-0	15-6	15-3	15-6	14-9
Heating surface, tubes and flues, sq. ft.	6,418	3,625.0	6,350	6,120	4,547	4,659.9	3,882	3,980.7	5,443	5,215	3,293.4	2,919.3	2,926	2,395
Heating surface, firebox, sq. ft.	360†	294.5	410	321.4	326	252	229	229	295†	293†	223.7	228.5†	227†	173
Heating surface, total, sq. ft.	6,994‡	6,579‡	6,760	5,526.9	4,873	5,039.2	4,111	4,245.7	5,801	5,638.4	3,517.1	3,147.8	3,153	2,568
Heating surface, superheater, sq. ft.	1,584	2,328*	1,310	1,002.0	1,368	890	879	948	1,377	1,329	774	594.4	633	545.8
Heating surface, equivalent, sq. ft.	8,907	8,070	6,528.9	7,814	6,653	5,960.5	6,014.1	4,990	7,866.5	6,901	4,291.1	4,039.4	3,786	3,113.8
Grate area, sq. ft.	81.9	99.2	99.9	78.4	72.2	72.2	53.6	53.6	88.1	88	66.75	61.3	55	53.1
Firebox, length, in.	162	149 5/8	174	126 3/16	117 1/4	126	108 1/16	127 1/2	132	132	114	111	108 1/2	106 9/16
Firebox, width, in.	108	78 3/4	109	114	96 1/4	97	96 1/4	75 1/4	96	96	84 3/4	80 3/4	73 3/4	71 3/4
Kind of fuel	Bit. coal	Oil	Bit. coal	Bit. coal	Bit. coal	Bit. coal	Bit. coal	Bit. coal	Bit. coal	Bit. coal	Bit. coal	Bit. coal	Bit. coal	Bit. coal
Tender, fuel capacity, tons or gallons	16	4,000	15	16	14	14	12	12	16	16	15	14	16	12
Tender, water capacity, gal.	10,000	12,000	9,500	9,500	9,000	9,000	9,000	8,000	10,000	10,000	9,000	9,500	7,500	7,500
Weight on drivers ÷ tractive effort	4.76	4.95	4.16	4.46	4.44	4.62	4.34	4.47	3.94	3.99	4.1	4.23	4.16	4.32
Total weight ÷ tractive effort	5.33	5.52	4.70	4.46	4.50	5.56	4.70	4.47	6.18	4.81	4.77	3.91	4.75	4.96
Tractive effort X diam. drivers ÷ equivalent heating surface	1,088.3	714.2	798.2	900.6	806.3	781.2	842.1	764.0	664.72	710.2	596.1	742.5	789.1	897.7
Equivalent heating surface ÷ grate area	102.9	108.8	81.4	65.4	99.7	79.2	69.1	96.9	89.29	78.4	81.8	64.3	66.0	58.6
Firebox heating surface ÷ equivalent heating surface, per cent.	3.89	3.31	5.08	4.92	4.17	3.79	4.58	5.11	3.75	4.25	5.33	5.20	5.65	6.00
Weight on drivers ÷ equiv. heat surface*	82.2	61.7	59.4	71.8	53.7	59.6	66.4	67	41.6	48.8	40.7	55.0	53.9	55.4
Total weight ÷ equiv. heating surface*	92.1	69.2	67	71.8	67.5	72	72	67	51.8	58.9	51.4	62.1	60.5	63.2
Volume both cylinders	51.3	30.1	34.4	30.0	32.2	29.3	20.0	19.1	27.9	26.2	18.50	17.0	17.0	15.7
Equip. heating surface ÷ vol. cylinders	180.5	296	235	217	243	244	276	249	281	264	232	238	223	198
Grate area ÷ vol. cylinders	1.75	2.72	2.88	3.33	2.44	2.95	3.62	2.81	3.15	3.36	6.7	3.60	3.61	3.24
Reference to photographs, drawings or description	R. A. G. M. E.† Am. Engr. Am. Engr.	R. A. G. M. E.† Am. Engr. Am. Engr.	R. A. G. M. E.† Am. Engr. Am. Engr.	R. A. G. M. E.† Am. Engr. Am. Engr.	R. A. G. M. E.† Am. Engr. Am. Engr.	R. A. G. M. E.† Am. Engr. Am. Engr.	R. A. G. M. E.† Am. Engr. Am. Engr.	R. A. G. M. E.† Am. Engr. Am. Engr.	R. A. G. M. E.† Am. Engr. Am. Engr.	R. A. G. M. E.† Am. Engr. Am. Engr.	R. A. G. M. E.† Am. Engr. Am. Engr.	R. A. G. M. E.† Am. Engr. Am. Engr.	R. A. G. M. E.† Am. Engr. Am. Engr.	R. A. G. M. E.† Am. Engr. Am. Engr.
1914-p227	1911-p171	1912-p287	1911-p182	1912-p587	1912-p420
1915-p160

* Equivalent heating surface = total evaporative heating surface + 1.5 times the superheating surface. † Includes 108 sq. ft. combustion chamber heating surface. ‡ Includes feed water heating surface. § Buck-Jacobs low degree superheater. a Includes 65 sq. ft. combustion chamber heating surface. †† Railway Age Gazette, Merriam's Dictionary.

CAR DEPARTMENT

THE SHIPPER, THE RAILWAY AND THE CAR MAN*

BY F. C. MAEGLY

Assistant General Freight Agent, Atchison, Topeka & Santa Fe, Chicago, Ill.

The shipper wants the railway to make it easier, cheaper and safer for him to load, ship and unload his freight. Any condition inherent in car equipment which makes it more expensive and inconvenient for him is prejudicial. On the other hand, anything that the car man can do to make it easier, cheaper and safer to load, ship and unload freight will improve the relation between shipper, railway and car man. Posing as the shipper's advocate, I feel free to offer criticisms and suggestions regarding the car man's performance.

Car men tell me that the draft rigging of railway equipment is the vital part. Many recommend that the draft rigging of all cars be sufficiently strong to withstand the shocks and strains incident to train and yard service. Any car, whether weak or strong, is likely to be placed in any position in long freight trains. The parting of trains, the break-in-twos, cause wrecks and damage my freight. I am anxious to have your co-operation in avoiding such damage. Your answer is that the cars are handled too roughly in many of the large terminal freight yards, and in many of the long freight trains; but has the car man done his part? Was the inspection of the cars adequate in the first place? Were the repairs sufficient? Where cars bear evidence of rough handling, was an effort made to locate the yards, and the trains, and the employees responsible? And were the proper representations made to the proper officers?

I recently inquired of a yardmaster, "Why so many break-in-twos, and so much car damage?" He took me to a freight car and pointed to features of the draft rigging which he said were "rotten"; he took me to another car with different style of draft rigging and stated that it gave far less trouble than the one first inspected; he took me to still another, and said that it was practically free from the faults mentioned in the other two.

The superintendent of motive power of a large railroad recently explained to me how very important it is to see that the air brake appliances are in good condition when locomotives and cars leave shops and repair yards or points of inspection. The general superintendent of a large railway system told me that if given 100 per cent air brake efficiency he would be able to solve the problem of trains parting on his district. A car man of much experience told me that too often cars are allowed to run with defective air brake hose and connections; that a campaign of closer and more effective supervision would help greatly to eliminate air brake failures.

Doubtless every member of the Car Foremen's Association is aware that the railroads of the United States have been expending annually about \$30,000,000 in the payment of loss and damage claims; therefore it will not be amiss for me to deal briefly with the several types of freight cars, and the features which tend to disturb pleasant relations between the shipper, the railroad and the car man.

BOX CARS

Why is it necessary to provide two men and a crowbar to open and close the side doors of a large percentage of the available box car equipment? If anyone disputes this, I invite him to visit a railroad yard at a market center where grain is

inspected and sampled. The damage frequently done to car sheathing in the mere process of opening and closing side doors of box cars with crowbars is appalling. If the car man is not primarily responsible, he is to blame in a secondary way for not formulating a definite protest against many of the present-day side door installations. A car man recently told me that fully 20 per cent of the delays to box cars for repairs is incidental to the side doors.

During the five crop years ending June 30, 1914, the Chicago Board of Trade weighing department registered grain leakage defects against the following number of individual cars:

During 1909-10	20,123 cars
During 1910-11	25,010 cars
During 1911-12	22,909 cars
During 1912-13	32,760 cars
During 1913-14	23,127 cars

Total 123,929 cars

Here the car man is presented with evidence of an average of 24,786 cars per year, or 69 cars daily that have grain leakage defects. Would it not be a good idea to take these cars at a time when the exact location of the defect is known, and when the minimum of attention by an effective car repairer would effectively prevent grain leakage by the same defect for a long time to come? The Chicago Board of Trade weighing department has offered to co-operate with the railroads in any systematic effort to eliminate these grain leakage defects; they have even agreed to furnish the interested carrier with a diagram showing the precise location and character of each defect as found by their deputies.

The front, top and rear creases of car doors should be rain tight, and I am happy to say that car builders are gradually approaching this much desired end.

All car door fasteners should be simple and effective, and when sealed, it should require the breaking of the seal to make it possible either to enter the car or remove freight through the doorway. The top and rear of the door should be so encased as to make it impossible to pry the door sufficiently to pilfer freight, and it should not be practicable with tools to remove the guides or lugs from the outside of the car while the car door is properly latched and sealed. Many box cars are now free of the last mentioned defects; some, however, are not.

The door posts of box cars should be about 100 per cent stronger. Car builders evidently have failed to reckon with the immense strains to which car door posts are subjected by the loading of bulk freight shipments, and particularly when releasing such commodities as bulk grain at the points of unloading. The structure over which the car door travels should be of such strength and rigidity as not to bulge or swell under heavy lading, or during abnormally wet seasons, so as to cause a bind between the door and the siding of the car when opening or closing the doors.

The car man who will provide effective and economical means of protecting car sheathing against shrinkage and warping should be amply rewarded. One car man has suggested that all sheathing boards be dipped in suitable paint before being applied; another is applying an angle iron all around the car body, as shown at A in the accompanying sketch. This angle iron is bolted through the car sill, and there have been marked benefits from it as regards grain leakage.

Try to prevent car builders from using hard wood for grain strips. Persuade them to use soft lumber and see that the grain strips are made considerably larger, and then even though it does take two men to apply them, have the sheathing

*From a paper read before the Car Foremen's Association of Chicago, May 10.

boards nailed to the grain strips, so that if a sheathing board should give way at the car sill, it will still be attached to the grain strip. There are some who advocate that the grain strip be not nailed to the car floor, but preferably to the sheathing boards. The sketch shows an extra heavy grain strip of soft wood, which, it will be noted, is bolted through the car floor and sill. The sheathing is nailed to the grain strip as well as to the car sill.

Some car men advocate the elimination of end doors, particularly in cars 40 ft. long or longer. It is questionable whether the end doors even in 36 ft. cars are worth the trouble they make. The repairs to the end doors of box cars are a considerable item. If they must be tolerated, let them be very small and at one end only, and let the joints be of such a character as to avoid the leakage of rain into, or of

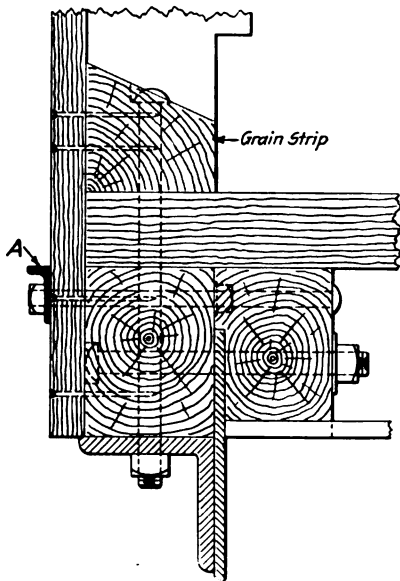

Methods of Preventing Grain Leakage

commodities out of the car. Every end door should be provided with an effective latch, which may be fastened from the inside of the car, thus rendering the sealing of the end door necessary only when the car is loaded with long material which cannot be handled through the side doors.

Car builders do not pretend that box car linings are grain tight at the belt rails. If linings could be made grain tight from the floor to carlines, the leakage of bulk grain during transit could be entirely eliminated. During the six months from January 1 to June 30, 1914, carriers reporting their loss and damage to the American Railway Association showed nearly \$600,000 paid out for loss of grain on account of defective equipment; \$854,000 was paid out during the same six months' period on grain and grain products. Estimating twice these amounts for the 12 months, we have from \$1,200,000 to \$1,600,000 annual loss of grain chargeable to box car defects. This is five per cent every year on from \$24,000,000 to \$32,000,000. A great many improvements could be introduced in the structure of the box car to prevent this drain upon the carriers' revenues. Speaking for the shipper of bulk grain, I would unhesitatingly advocate a galvanized liner back of the car lining, and in matching the car lining I would seek to taper one edge so as to insure against grain lodging on the longitudinal edges. Shippers of flour and other like package freight, particularly the shipper of fragile packages, would greatly appreciate a smooth surface instead of the sharp edges at the belt rail and the bottom. The car man will object to this on the ground that the lack of ventilation between lining and sheathing would lead to premature decay. Some car men, however, take issue with this view and say that they have proof of its fallacy by a study of the decay

in like parts, and in the sills of refrigerator cars. One of the grain carrying road's expenditures for burlap and paper to patch minor defects during one shipping season amounted to between \$50,000 and \$60,000. It is questionable whether a carrier ought to supply shippers with free burlap to properly secure their grain in cars, the burlap pertaining to private packing rather than public equipment, and all cars from the newest to the oldest require adequate cooping for bulk shipments to insure against leakage; nevertheless, competition and the disparity between individual freight cars available for bulk grain loading has been such as to cause carriers to supply these accessories in addition to grain doors. The same road's annual expense for grain door renewals has averaged about \$105,000 a year, on an annual movement approximating 75,000 cars. However, many of the grain doors are lost by reason of shipments discharging at destinations beyond the originating carrier's rails.

If you car men desire to establish permanently happy relations between shipper, railroad and car man, please provide a box car that is free of the several defects just mentioned.

COAL CARS

Hopper bottom, drop bottom and drop side cars should be so constructed and so maintained that the drops and hoppers when closed will be secure against leakage of the commodity from the car during transit. Chains and other fastenings, and the gears used to operate them should have an immense factor of safety over and above the anticipated strains, and every necessary preventive should be provided against the warping of material and consequent leakage defects. The apparatus used to hold hoppers and drops should be simple and easy to operate, and the many shelves and dirt collecting pockets now existing in various types of hopper and drop bottom cars, which collect and conceal refuse, also the false decks of projecting ends of hopper bottom cars, should be eliminated for the reason that refuse will gather thereon, often to the detriment of the railroad, the shipper and the consignee.

STOCK CARS

The stock shipper desires a smooth interior with spaces between slats only wide enough to admit of sufficient ventilation of the stock while in the cars. Many of these spaces are now too large. It is to be hoped that a convertible stock car will some day be devised so that this type of car may be used more extensively for the transportation of other commodities. Several of the roads have lined stock cars with heavy fibre or felt paper at an average expense of about \$17 a car. These cars did well during the temporary period of such special service, and provided just that much relief against box car shortage during the rush of grain.

SAVING WASTE GRAIN.—The Rock Island agent at the Silvis (Ill.) transfer, constructed a rat-proof grain bin last Fall, holding 25 to 30 bushels of grain, and began systematically to save the grain recovered in the sweeping of empty cars placed at the platform for loading. This was done at practically no expense, as it was necessary to clean the cars before loading and regular employees were utilized in the work. As opportunity offered he also collected any grain spilled from bad order cars in the Silvis yards. This grain was sold from time to time and the receipts turned into the company treasury through the local agent. While this grain was damp and more or less dirty, it made good chicken feed and no difficulty has been found in selling it at \$0.80 per hundred pounds. The amount recovered in four months was as follows:

November, 1914	\$15.05
December, 1914	71.80
January, 1915	64.10
February, 1915	116.60
Total	\$267.55

AIR BRAKE ASSOCIATION CONVENTION

Moisture in Compressed Air Apparatus, Pneumatic Signal Operation, and 100 Per Cent Operative Brakes

The twenty-second annual convention of the Air Brake Association was held in Chicago, May 4 to 7, L. H. Albers, New York Central Lines, presiding. The meeting was opened with prayer by Rev. Martin J. Magor, and the address of welcome was made by Robert Quayle, general superintendent of motive power and car department, Chicago and North Western. Mr. Quayle complimented the association on the work of the past and pointed out its possibilities in the future. He spoke of the importance the air brake engineer bore to the railroads and the public, stating that such was their work that men of good character, patience and thoroughness were required. The air brake men are responsible to a large extent for the safe and careful operation of trains and their work and instructions should be of the first quality. The problems presented by the air brakes are many and only by persistently keeping after them may they be conquered.

PRESIDENT'S ADDRESS

President Albers called attention to the lack of standardization of brake equipment for passenger cars, and was of the opinion that a committee from both the Air Brake Association and the Master Car Builders' Association could by careful study decide on some standard valve of simple construction that would do much to relieve the situation. He spoke of the difficulties experienced, principally "stuck-brakes," with the various types of passenger air brake equipment now in use. While the new P. C. equipment provided temporary relief from the troubles experienced with the P. M. and L. N. type of equipment, its complexity renders it difficult to locate immediately and definitely defects which arise in train service.

Mr. Albers also called attention to the necessity of economy in the maintenance of air brake equipment with full consideration for safety. On the New York Central Railroad, East of Buffalo, tests have been in progress for a period of 18 months, on 18 dining cars, and to this date 16 cars are still in actual service with an aggregate mileage of 2,321,136 miles without once having received any attention or lubrication except when they were applied. None of these cars have given any detention on account of the air brake equipment, nor has any valve been removed except for examination after 12 months had passed. He stated that if the cleaning period, instead of being three months as at present, were extended to four months the annual saving to a road having 1,000 P. C. equipment cars would amount to approximately \$1,640, and if extended to six months the saving would be approximately \$3,280. With the P. N. or L. M. type of equipment this saving would be \$420 and \$840, respectively. He believed that if these particular features of air brake maintenance were given proper attention at the time of cleaning the time between cleanings could be lengthened with a consequent saving.

MOISTURE IN YARD TESTING PLANTS

The benefit derived by having compressed air available in railroad storage yards, so that the air brake apparatus can be properly inspected, has long been recognized by air brake men. However, the importance of providing what is generally termed "dry air" has not been given the consideration it should have in some of the installations.

The importance of preventing water entering the air brake system when passenger trains are charged in the Mott Haven yard of the New York Central, which is the passenger car storage yard for the Grand Central Terminal at New York City, was recognized by the management, and in the fall of 1913, an

air cooling plant was erected and has been in successful operation since. No trouble from freezing of the radiating pipes has occurred and the plant has absolutely prevented any precipitation taking place in the yard pipe.

The two compressors at the Mott Haven yard have a total capacity of 2,500 cu. ft. of free air per minute. There was provided in this plan 3.2 running feet of $\frac{3}{4}$ in. pipe for each cubic foot of free air that the compressor was capable of producing, or, in other words, 8,018 ft. This is made up into 48 sections, each of which is composed of two headers and 18 pieces of $\frac{3}{4}$ -in. extra heavy galvanized pipe about 111 $\frac{3}{8}$ in. long spaced on 2 $\frac{1}{2}$ -in. centers. The upper header is 6 in. in diameter and the lower one 8 in. in diameter. Both are of extra heavy wrought iron. Cast iron caps, tapped for 1 in. pipe at the center, are used to close the ends of the headers.

The lower header is tapped for 1 in. pipe at the center lengthwise and 180 deg. from the $\frac{3}{4}$ -in. holes, this connection being used for a drain. Each of the 18 pieces of $\frac{3}{4}$ -in. pipe are made up of two sections of different lengths.

The long and short pieces were alternated in the headers, so that the joining of two sections in any one of the 18 pieces does not interfere with any of the others. The two outside pieces, that is, the first and eighteenth pieces of $\frac{3}{4}$ -in. pipe are joined together by the use of $\frac{3}{8}$ -in. brass ground joint unions. The other 16 pieces of $\frac{3}{4}$ -in. pipe are jointed by the use of slip joints, known as grip couplings, which are manufactured by the Ware Coupling & Nipple Company, Ware, Mass. The 48 sections are arranged in two groups of 24 each, designed so that all the piping is accessible, there being ample clear space to work in. Sufficient space is provided for the circulation of the atmosphere around the cooling pipes, a very important factor.

There are two storage reservoirs, 4 $\frac{1}{2}$ ft. in diameter, by 11 ft. high, and the air first passes through both of these reservoirs. From the storage reservoir air is delivered to the yard through a 6-in. main and can be directed through the manifold condenser, or by-passed around it. A 6-in. pipe between the two groups, extends from one end to the other near the top. This is the admission pipe. It has 24 pipe connections, 2 in. in diameter, from each of which two 1-in. pipes branch. Each 1-in. pipe is connected to the end of the upper header of a section, directly opposite the 2-in. risers, one in each group. The outlet is a 6-in. pipe, on the outside of either group, running the entire length and across one end. The connection to the main pipe is made by a 6-in. riser. Connections are made to the outlet pipe from the lower header of each section with 1-in. pipe.

These connections to the section are diagonally opposite to the inlet connections, it having been found that with the inlet and outlet on the same side of a section the flow of air was greater through the cooling pipe nearest that side. There are cut-out cocks provided so that any one of the 48 sections can be cut out without interfering with any of the others. Each lower header is provided with a drain cock which is in communication with the sewer pipe. Also, there is a drain provided for the inlet and outlet pipes.

The report is signed by Mark Purcell (Nor. Pac.), and M. F. Gannon (N. Y. C.).

DISCUSSION

Some roads have found that very good results can be obtained by placing reservoirs in the yard piping to catch the moisture as it becomes condensed in the pipes, these reservoirs to be drained twice a day. It was also pointed out that the compressor should have its intake located outside the building where it could obtain air as cold as possible. Trouble has also been

experienced with the yard pipes becoming full of water when the hydrostatic tests were made on the air system reservoir, the water leaking by the valves that were not in good condition. When such tests are made it was recommended that the pipe connections to the yard piping be disconnected.

The discussion also developed into the consideration of the accumulation of moisture in the train line. Sufficient radiating surface should be provided between the compressor and the main reservoir, this amount varying from 18 ft. to 40 ft. of 1¼-in. pipe. It should be located so that it will drain into the main reservoir. It was also recommended that two main reservoirs be used, one of which would serve as a drain for the air system. On large Mallet locomotives it has been found necessary to provide three such main reservoirs. It was also stated that where the air capacity was not sufficient and the pumps were called upon to pump the brakes off the train, trouble would be found with the accumulation of moisture in the train line.

Excellent results have been obtained by having the roundhouse hostlers open all the drain cocks on the locomotive and tender as soon as the engine was housed. Care should be taken in the locating of the various air brake equipment. The distributing valve should be located so that it will be drained, and the main reservoir should not be located too near the firebox, as in such cases it has been found that the air would not cool sufficiently to precipitate the moisture. Where the power reverse gear is operated by both steam and air, the air line should be provided with a check valve so that the moisture from the steam could not work back into the air system. Centrifugal dirt collectors have been found to serve admirably as drains for the train line, and in some cases two are installed on the cars for that purpose.

OPERATION OF THE PNEUMATIC TRAIN SIGNAL

Possibly the largest factor in the correct operation of the signal device is maintenance. This is particularly true of the amount of leakage allowed in the signal line. With the long cars which are in service today, the most frequent place for leakage to develop is at the hose connections, due to the improper location of the pipes at the end of the car, which results in false signals being transmitted. This destroys the confidence of the crew in the signal system. In order to get the best results, the location of pipe and hose should be as recommended by the M. C. B. association.

Where the reducing valve of the slide valve feed valve type is used, the opening through the choke of the combined strainer and check valve has been increased on some roads from 3/32 in. to ½ in. A test of a twelve-car rack shows very little difference between the two; in fact, the condition of the feed valve will affect the recharging of the line as much as the difference in the size of the choke. Where this type of reducing valve is used they should be cleaned once a month, and subjected to the same rack test as the feed valves used to control the brake-pressure.

In endeavoring to improve the operation it is necessary to first ascertain the conditions under which the signal is operating. Recording gage charts attached to the signal line on the rear car will indicate the average operating conditions as follows: the pressure carried in signal line; all reductions in this pressure, whether made by pulling cord or by hose couplings leaking when passing over crossovers, switches, etc.; and the time required to recharge the line after reductions have been made. It has been found necessary for the trainmen to make a reduction at the car discharge valve of not less than one second duration, and pause between the reductions two to three seconds, or approximately three times as long as the time of the reductions.

While there is a limit to the length of signal line which can be operated successfully with the present pneumatic signal, it is believed that the electro-pneumatic signal which does not have the same limitation, will eventually be adopted. During the past year a steam train equipped with the electro-pneumatic

system has been in regular service, covering 180 miles a day, with good results.

The construction of the signal valve is such that very careful workmanship is required in order to have the correct clearance between the valve stem and its bushing. If this clearance is insufficient, the valve will be too sensitive and give false blows of the whistle for very slight signal pipe reductions. If the clearance is excessive, heavier reductions are required than when the fit is tight. The average signal valve has about .0005 in. difference between the diameter of the stem and the bushing. The manufacturers have found that where this difference is less than .0002 in., or more than .0015 in., the valve will not meet the requirements.

The small projection at the bottom of the valve stem is 1/32 in. long, and with a proper fit in its bushing, requires that the diaphragm must raise more than 1/32 in. before enough air can flow past this projection to blow the whistle. If the length of this projection is materially reduced, or if its fit is too loose, very slight reductions of signal line pressure, or even the vibration of the valve itself, such as would be brought about by the engine running over rail joints, might cause the sounding of the signal.

In order to more closely approximate actual service conditions, the manufacturers have investigated the operation of signal valves with a certain specified orifice, venting to the atmosphere at all times, to represent the leakage. The results of the tests show that in order to affect the signal valve operation at all, leakage must be excessive and above the amount which should be permitted in service, and it has therefore been concluded that a test involving leakage is unnecessary and of no practical value.

The manufacturers' signal valve test rack consists of sufficient piping to represent 20 passenger cars, accompanied by the proper piping, air signal reducing valve, air signal valve and air whistle the same as used in service, the signal reducing valve being set at 40 lb. The following method is followed in testing a 15-car train, a 10-car train and a 2-car train. The cock on the rear end of the last car must be closed at all times, and all other connecting cocks must be open, the system being charged to 40 lb.

Assemble the signal valve on the rack, and slowly cut it in. After the valve is charged, and before the whistle is assembled on the rack, make several reductions with the discharge valve on car No. 1, to properly seat the valve stem. After the valve is recharged, coat the connection to the whistle with soap suds to determine if leakage exists past the valve. After completing this test, assemble the whistle on the valve.

First, test the signal valve on a 15-car train. With the system fully charged to 40 lb., and all the connecting cocks open, make five reductions with the discharge valve on the fifteenth car, each reduction to be made by holding the discharge valve fully open for one second, allowing 1¼ seconds between the reductions. Following each reduction, the whistle must give one distinct blast. If, during this test, or any of the following tests, the whistles give two short blasts after one reduction, it indicates that the valve stem is too short or the diaphragm is too weak, requiring too light a difference in pressure to raise it. If one long blast is obtained, or the whistle does not stop blowing between the reductions, it indicates that the valve stem has excessive friction, which may be caused by either the valve stem or the diaphragm.

Before commencing reductions in the succeeding test, the signal line pressure must be charged to 40 lb. Then repeat the tests on the eighth and first cars. Next, test the signal valve on a 10-car train by closing the cock on the rear end of the tenth car, and repeat the above test on the tenth, sixth and first cars, after which, test the signal valve on a 2-car train by closing the cock on the rear end of the second car and make the above test on the first car. After the test, coat the entire valve with soap suds to detect porous castings.

Where trouble is experienced with false signals being transmitted while the train is running, a recording gage should be attached to the signal line, and if the corresponding reductions are not shown on the chart, it is generally found that the signal valve on the locomotive is too sensitive. The valve should be removed from the locomotive and tested on a suitable rack. The illustration shows a 12-car test rack used at Elizabethport shops,

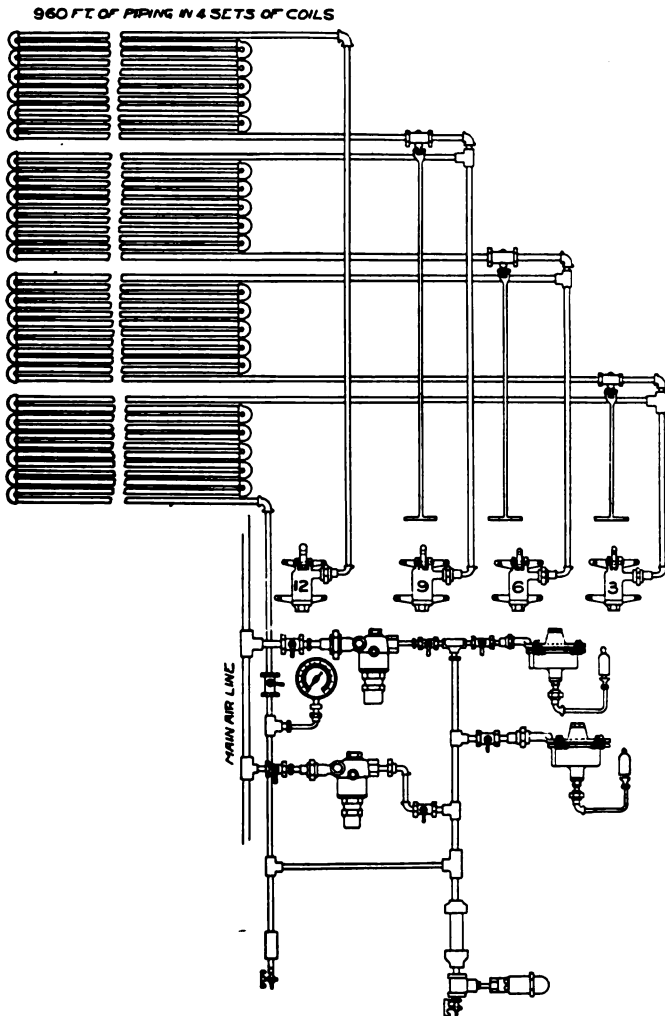

Twelve-Car Signal Valve Test Rack, Elizabethport Shops, Central Railroad of New Jersey

C. R. R. of N. J., where all valves for the entire road are tested after repairs are made.

The report is signed by: L. N. Armstrong (Penn.), and H. L. Sandhas.

DISCUSSION

The consensus of opinion in regard to the pneumatic signal was that in its present state it is not an absolutely reliable device. On trains of 25 to 30 cars in length considerable trouble is experienced with leakage, and in some cases trouble has been experienced with 16 to 18 cars. Where trains are of such a length it was believed expedient to increase the signal train line pressure to 60 lb. Greater care should also be taken in the proper maintenance of the present pneumatic system. On some roads no engine is allowed to depart from the terminal without the signal system being in satisfactory operation, while on others a system has been adopted where in case the pneumatic signal becomes inoperative the conductor shall make use of the conductor's valve and hand signals. Some roads have found that with the 1/8-in. choke opening in the signal line the leakage may more readily be determined, without interfering with the correct operation of the signal. In some cases it is found

necessary to clean the signal valve as often as once a week. Mr. Armstrong, in closing his paper, stated that electric energy sufficient to operate an electro-pneumatic signal system could be obtained from dry cells or from the electric lighting system on the cars or locomotive.

100 PER CENT OPERATIVE BRAKES IN FREIGHT SERVICE

The general opinion is that an operative brake is one in which the piston moves out of the brake cylinder far enough to close the leakage groove, and not more than 10 in. when a full service brake application is made from at least a 70-lb. brake pipe pressure, remains so until the usual inspection is made, and releases properly in the usual methods resorted to in making ordinary terminal tests; the only other requirement is that the foundation brake gear be connected throughout to bring the shoes to the wheels. The second consideration is the question of what constitutes 100 per cent operative brakes. Our opinion in this respect contemplates that each brake in a train be operative as above stated and so connected that they may all be operated from the locomotive. This will constitute 100 per cent operative and meet all the requirements but one, namely, efficiency. The highest efficiency required to meet general conditions is that the train may be controlled by the engineer without the assistance of trainmen with the ordinary hand brake.

Unfortunately, while the requirements of efficiency reduce the difficulty of providing an operative brake, they also result in ability to control trains with a low individual brake efficiency throughout the train or a small percentage of brakes operative for service requirements, while certain other conditions automatically increase the necessary efficiency and number of operative brakes, and the greater the number of cars involved, the more pronounced are these results. The introduction of the yard pressure lines where trains are made up sufficiently in advance of leaving time, would give an opportunity to make the brake inspection and correct many defects before the engine was placed on the train for departure.

Any one point on a large system attempting to run 100 per cent operative brakes would be immediately confronted with a prohibitive number of cars with inoperative brakes and a congestion that would cause serious delays resulting in this particular point being criticized for tying up traffic. Relief for this particular terminal could only be brought about by allowing inoperative brakes to proceed, or by increasing the amount of the brake work done at the terminals on either side. It can readily be seen that any one railroad attempting to run 100 per cent operative brakes would be placed in almost the same position as the terminal above mentioned, and the same rule in regard to relief would apply between the railroads involved.

The difficulty of establishing the practice of cleaning brakes on cars in trains at large terminals where the tracks extend over a large territory is expensive, as it is hard to get men and material to the cars and men are idle a large part of their time. But again we find that at many small terminals where very little switching is done on the train outside of changing engines and cabooses, and where the repair track is close to the train yard, that air brake repairs can be made in trains successfully and economically, as the men in this case can be used on the repair tracks when no trains are in the yard. Yard air lines at these terminals are necessary to test out work of this kind and additional time allowed to trains in terminals to give the car men an opportunity to do the work before, or after, the train is switched. Yard train testing devices must also be provided at terminals in order that cars arriving in trains with brakes "cut out" may be tested to ascertain what, if anything, is wrong, and to test work on the brakes after it is completed.

After the facilities and materials are provided, then comes the proposition of procuring men who are competent and reliable to do the work or men who can be educated in a reasonable length

of time. The better supervision we have, the less trouble we have from this source. One of the conditions we find it hard to overcome is the careless manner in which some of the air brake work is done.

A system must be inaugurated to catch the disabled brakes as soon as practicable after the defect becomes apparent. With this in view, what might be called "dead lines" should be designated at reasonable distances over the road—terminals where facilities are the best, as 100 per cent points where no brakes that are inoperative are allowed to pass, regardless of lading. At all terminals where there are facilities, dead freight loads and empty cars with inoperative brakes should be caught and repaired. All cars on repair tracks should have their brakes carefully tested, and if the cleaning date is over nine months old on home cars, the brakes should be cleaned. This would avoid the necessity of putting the car on the repair track again in so short a time, and when it might possibly contain an important load.

If we wait until the trains are made up in the yard to make inspections we will have delays and bad cars, but if we require the men on all incoming trains to have the train fully charged and then make the required application of brakes before cutting off, the air brake inspection can be made at the time of usual train inspection, and any cars "bad ordered" can be switched out in the usual switching time.

The question arises as to what is to be gained by increasing the number of operative brakes. One reason is to provide a wider margin of safety by the ability to stop in a shorter distance in cases of emergency. The reason more frequently encountered, however, is the resultant reduction of slack action in long trains, which contributes largely to troubles arising from break-in-twos.

The report is signed by: Geo. H. Wood (A. T. & S. F.), and S. C. Wheeler (C. B. & Q.).

DISCUSSION

F. B. Farmer, of the Westinghouse Air Brake Company, strongly recommended the employment of a general car brake inspector for the purpose of instructing and demonstrating to the cleaners of the freight car air brake equipment how they should do their work, and to check them in their work. He also spoke strongly in favor of the incoming tests of the brakes in order that the defects may be located and corrected while there was sufficient time to do so. This will eliminate a lot of trouble and delay that would ordinarily be caused when the brakes are found defective on the outgoing tests. He also spoke of the tendency for some of the comparatively level roads to absolutely neglect the maintenance of the retaining valves. This causes a great deal of trouble for the roads receiving such cars in the mountainous districts, and greatly interferes with the expeditious transportation. He was strongly in favor of the "dead line" as described in the paper, and stated that at one point on a large road that operated this dead line system 75 per cent of the brakes cleaned had not run over nine months, showing that this work is not always done as carefully as it should be. Lack of knowledge and hurried work have been a great factor in the improper maintenance of brakes, and oftentimes are the basis for charges of dishonesty in doing the work.

Some roads are having very good success with carding freight cars with inoperative brakes, permitting them to go without tying up the train and having the work done at the next terminal. The trainmen have also been instructed to place defect cards on the cars as they become inoperative on the line, and also those cars that are picked up enroute. Trouble has also been experienced in using shop line pressure in testing the air brakes on the rip track, as many cases were found that where the brakes would operate under this high pressure they would not operate when on the train under a pressure of 70 lb. To overcome this the Louisville & Nashville has in use a device for reducing this pressure to the proper amount. One member strongly objected to the practice followed by many roads in allowing the man that cleans the

triple valves to test them, as when this work is done piece work the men are apt to pass valves that are not in proper condition.

Walter V. Turner, chief engineer of the Westinghouse Air Brake Company, encouraged the men to do all in their power to influence their superiors to give them the proper facilities for keeping the brakes in the necessary good condition. Persistence and nerve in carrying out what they believe to be absolutely necessary in the maintenance of brakes is required to get the right results.

Mr. Wood, in closing the paper, believed that brake cylinder conditions should be more carefully watched, and also called attention to the large number of triple valves that were found defective after having only run for about six months. All air brake work should be given careful supervision and checking before it is permitted to pass out of the repair yards.

HAND BRAKES ON HEAVY PASSENGER CARS

No scheme of hand brake control for heavy passenger cars presented for consideration appears to be entirely satisfactory. As the weight of passenger equipment cars increases, the desired braking power can only be obtained by increasing the hand leverage. Hence, where the desired hand brake power is provided through a sufficiently high multiplier of the leverage, there is introduced the objectionable feature of loss of time in winding up the long hand brake chain necessary to take up the slack and bring the shoes against the wheels. Because of this it has not been found an easy matter to provide a winding shaft or barrel of requisite capacity to accommodate the chain satisfactorily with the different amounts of slack or of piston travel existing.

It is generally recognized that time, as well as power, is an important factor in hand brake operation, and with this in view designs of hand brakes have been gotten out with the object of providing a quick take-up of the slack and then of increasing rapidly the leverage so that adequate shoe pressure may be supplied. Arrangements of this character have been satisfactory in a degree, but because of the variations in brake shoe wear and slack, the point on the winding cone at which the free slack is taken up is not always the one at which the desired higher leverage is obtained.

The difficulty in the way of satisfactory single truck operation appears to be one method of connecting the hand brake lever to the cylinder lever pull rod so that when the hand brake is being operated the air brake cylinder levers need not be moved. Some experimental designs of single truck hand brakes now on trial have sufficient merit to warrant further development.

It appears that in designing a hand brake gear for heavy passenger cars effort only should be made to provide power sufficient to enable switching crews to control them in yard movements.

The report is signed by: John P. Kelly; C. W. Martin (Penn.); L. P. Streeter (Ill. Cent.), and F. J. Barry (N. Y. O. & W.).

RECOMMENDED PRACTICE

Aside from typographical and other corrections made to conform with the M. C. B. standards and recommended practices, it was recommended that the capacity of main reservoirs for passenger and switch engines should be not less than 40,000 cu. in., and for freight engines not less than 60,000 cu. in., an increase of not less than 25 per cent above these figures being desirable when the air compressor displacement capacity is 120 cu. ft. or more per minute. It was also recommended that main reservoirs should be tested with the hammer test with no pressure in the reservoir and followed with a hydrostatic test, using a pressure equal to 150 per cent of the maximum working air pressure, the hammer test to be made each time the engine receives general repairs, and the hydrostatic test to be made once a year.

Under the heading of "Tests for Feed Valves," it was recommended that feed valves should be tested and removed from service if they are not sufficiently sensitive to open with a maximum difference in pressure of 2 lb., with a brake pipe leakage of from 7 to 10 lb. per minute. The following test was also

recommended for all feed valves after they have been cleaned or repaired, the test rack shown in the illustration being the standard slide valve, feed valve test rack:

Test No. 1.—After applying the feed valve to the rack with its spring box and diaphragm removed, open cock *C* and 7, and close cocks *A* and 7 (shown at the left). Regulating valve leakage can then be noted as one end of the valve is exposed. If the supply valve is leaking it will be indicated by the discharge at the port on one side of the regulating valve stem in the recess under the diaphragm. In case of leakage at the latter port, make sure it is not between the two ports across the feed valve gasket as the effect is the same as with a leaky supply valve. Test the two cap nuts with soap suds. No leakage existing, or having been remedied, close cock 7 (shown at the right); replace the parts removed; open cocks (shown at the right) and *A*; and then tighten up on the regulating nut, previously left slack until the valve begins to vibrate rapidly. This will be shown by intermittent puffs of air at cock *A*. If the piston or its bushing are new allow the valve to vibrate for at least 10 minutes, then proceed.

Test No. 2.—Close bleed cocks *A* and *C*; open cock 7 (shown at the left), and adjust feed valve to the desired pressure. With brake pipe volume fully charged, open bleed cock *C* and note the

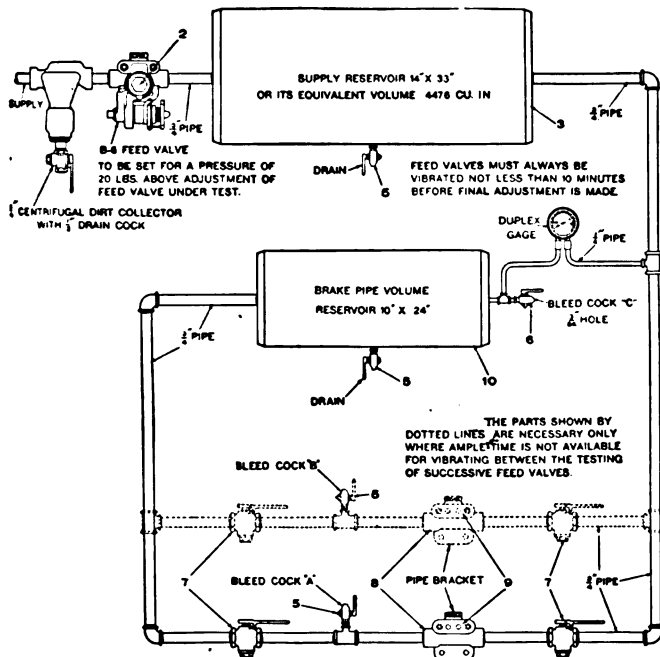

Diagrammatic Arrangement of Slide Valve Feed Valve Test Rack

drop in pressure required to open the feed valve. It should be less than 2 lb. Also when the feed valve opens note whether the pressure in the brake pipe volume is promptly restored to the original amount, as it should be.

If the drop is 2 lb. or more and is restored promptly it indicates a tight piston or other undue friction. If the drop in pressure is 2 lb. or more before the feed valve opens and the pressure then remains practically constant at this lower pressure, the piston is too loose in its cylinder. A wider variation than the standard limit between the opening and closing points of the feed valve may be caused by the diaphragm spindle of the regulating portion, which guides the regulating spring, binding considerably at any point. Such resistance aids the regulating spring when the pressure is nearing the closing point of the feed valve and resists the action of this spring when a falling pressure should cause the feed valve to open.

Test No. 3.—With the brake pipe volume charged and the bleed cocks *A* and *C* closed, close cock 7 (shown at the right); reduce the brake pipe pressure 5 lb. below the setting of the feed valve, using bleed cock *A*; then, first being sure that there is 20 lb. excess pressure, open cock 7 (shown at the right)

quickly and note the overcharge of brake pipe pressure. This must not be more than 2 lb. If the overcharge exceeds 2 lb., the piston fit is too close or the piston is oil or water packed. Wipe the piston and its cylinder dry and test again before making the piston a looser fit.

The report is signed by: S. G. Down (W. A. B. Co.); G. R. Parker (G. N.); H. A. Wahlert (W. A. B. Co.); J. R. Alexander (Penn.), and N. A. Campbell (N. Y. A. B. Co.).

OTHER BUSINESS

During the convention an afternoon was given to the air brake appliance supply men, who talked to the members concerning their products. On Thursday afternoon the association was addressed by Walter V. Turner, of the Westinghouse Air Brake Company; N. A. Campbell, of the New York Air Brake Company, and J. R. Snyder, of the Pittsburgh Air Brake Company. Mr. Turner spoke of the developments during the past year, and told how the New York subway had increased its capacity by the adoption of the electro-pneumatic brake. Mr. Campbell gave an illustrated talk on the New York electro-pneumatic brake. Mr. Snyder gave an illustrated talk on the new air brake equipment furnished by his company.

The association was also addressed by E. H. De Groot, Jr., superintendent of transportation, Chicago & Eastern Illinois, and M. H. Haig, mechanical engineer, Atchison, Topeka & Santa Fe.

The following officers were elected for the ensuing year: President, J. T. Slattery, Denver & Rio Grande; first vice-president, T. W. Dow, Erie Railroad; second vice-president, C. H. Weaver, New York Central lines west of Buffalo; third vice-president, C. W. Martin, Pennsylvania Railroad; secretary, F. M. Nellis, Westinghouse Air Brake Company; treasurer, Otto Best, Nathan Manufacturing Company. The executive committee is as follows: T. F. Lyons, New York Central lines west of Buffalo; J. F. Barry, New York, Ontario & Western; L. P. Streeter, Illinois Central; Mark Purcell, Northern Pacific; G. H. Wood, Atchison, Topeka & Santa Fe.

It was voted to hold the next annual convention at Atlanta, Ga., on May 2 to 5, inclusive.

STEEL PASSENGER TRAIN EQUIPMENT

To ascertain the progress of the building of steel and steel underframe passenger equipment and to develop the cost of reconstruction in steel of the present wooden passenger equipment in the country, the Special Committee on Relations of Railway Operation to Legislation issued a circular letter to the railways on January 2, 1915. Replies have been received from 284 companies operating 245,721 miles in the United States, and 62,112 passenger equipment vehicles, with 956 under construction on January 1, 1915. The tabulations based on these replies have been published in Bulletin No. 67, showing that of the cars under construction on January 1, 725 were all-steel, 228 steel underframe and 3 wood, and of the 4,495 cars acquired in the calendar year 1914, 3,355 were all-steel, 940 steel underframe and 200 wood, including 56 cars purchased second hand. Of the total number of passenger train cars in service on December 31, 1914, 12,900 were all-steel, 5,700 steel underframe and 43,512 were wood. The character of the various classes of equipment in service on December 31, 1914, is shown in the following table:

	Steel	Steel underframe	Wood
Postal	888	217	461
Mail and baggage	668	404	2,562
Mail, baggage and passenger	31	56	579
Baggage and passenger	528	227	3,519
Baggage or express	1,478	1,315	7,507
Passenger	5,105	1,704	22,266
Parlor, sleeping and dining	3,200	1,526	5,353
Business	32	109	730
Motor	970	142	535
Total United States	12,900	5,700	43,512

A table is also given in the bulletin showing that for the cars acquired during the past six years the percentage of all-

steel cars has increased from 26 to 74.6, while the percentage of steel underframe cars has ranged from 14.8 per cent to 30.4 per cent, and was 20.9 per cent in 1914. The percentage of wooden cars has decreased steadily from 51.4 per cent in 1909 to 4.5 per cent in 1914.

Another table shows that the number of all-steel cars in service has grown from 629 in 1909, an increase of 1,951 per cent, while the number of steel underframe cars has grown from 673, an increase of 747 per cent. A total of 4,614 wooden cars has been retired in three years. Of this number 1,048 were retired during the calendar year 1914. The bulletin also gives the following table showing the approximate cost of replacement of wooden cars:

APPROXIMATE COST OF REPLACEMENT OF WOODEN CARS

	Number	Average cost	Amount
Postal	461	\$11,000	\$5,071,000
Mail and baggage.....	2,562	10,000	25,620,000
Mail, baggage and passenger.....	579	10,000	5,790,000
Baggage and passenger.....	3,519	10,000	35,190,000
Baggage or express.....	7,507	8,500	63,809,500
Passenger.....	22,266	12,800	285,004,800
Parlor, sleeping, dining.....	5,353	22,000	117,766,000
Business.....	730	15,000	10,950,000
Motor.....	535	20,000	10,700,000
Total	43,512		\$559,901,900
Annual interest charge at 5 per cent.....			\$ 27,995,095

The charge to operating expenses under the classification accounts of the Interstate Commerce Commission, assuming a value of \$4,000 per vehicle replaced, would be \$174,048,000.

Replies were also received from 10 companies operating 27,628 miles in Canada, showing that of a total of 5,366 passenger train cars in service on December 31, 1914, 79 were all-steel, 187 steel underframe and 5,100 were wood. Of 57 cars under construction on December 31, 38 were all-steel, 16 steel underframe and 3 wood.

by means of the hat rack shown in the illustrations. This has been found to overcome the difficulty of the frame loosening and is also appreciated by passengers, as it avoids the necessity of reaching over the heads of others in order to place their hats on the overhead hooks and to remove them when leaving the car. Spring cushions have been eliminated, as it has been found that they are expensive to maintain. The absence of gimp is also noteworthy, the leather being simply folded in, making a clean, smooth surface. These

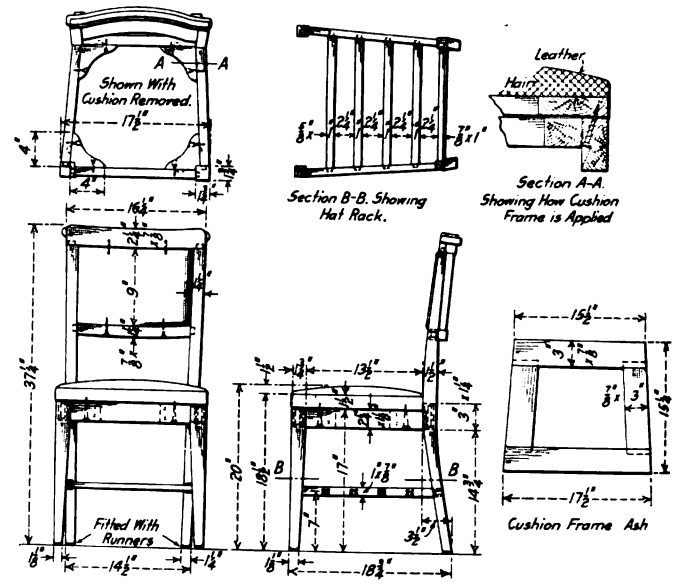

Canadian Northern Dining Car Chair

DINING CAR CHAIRS

For five years the Canadian Northern has been experimenting to obtain a satisfactory design of chair for use in dining cars. Out of seven different designs tried out in service during this period the one shown in the engraving has met with

chairs have so far not needed any repairs and are both light and substantial.

The child's chair shown replaces the usual high cushion and has been favorably received by patrons of the road. As shown in the engraving, it consists of a box or frame upholstered in leather, and with two side pieces and a leather foot

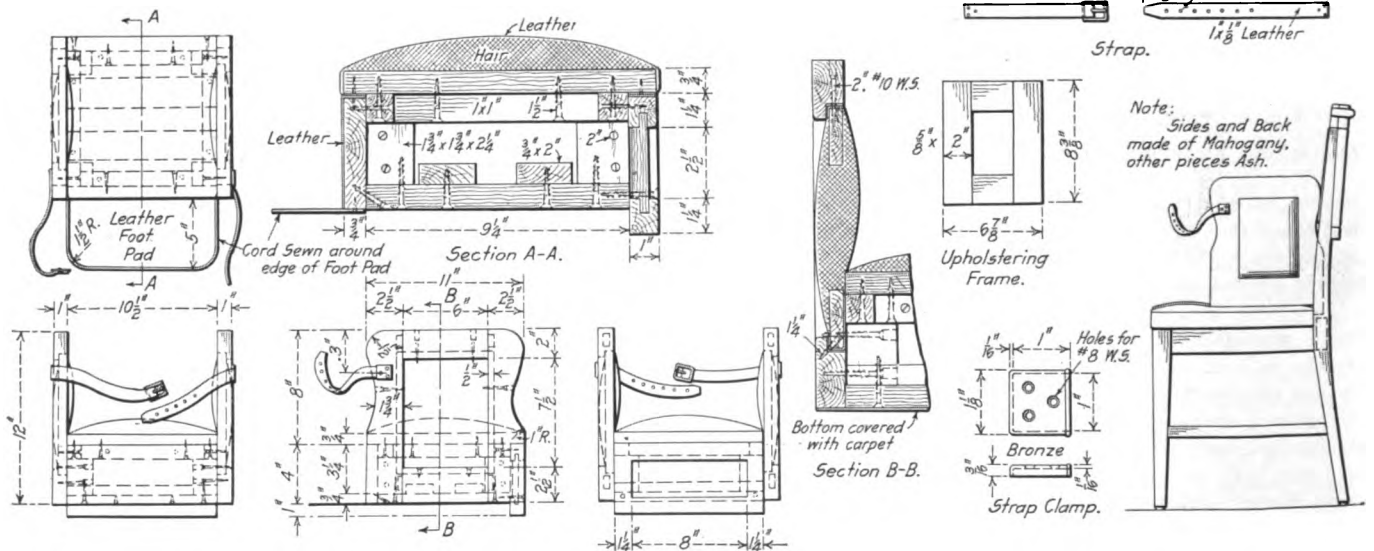

Child's Chair Used in Dining Cars on the Canadian Northern

marked success and has proved much more satisfactory than any of the others.

The principal weakness in most chairs is the difficulty of keeping the frames from racking loose. This has been overcome in the Canadian Northern design by bracing the legs

pad. The chair is placed on the seat of one of the ordinary dining chairs, the back of which forms the back of the combined chair. The designs for these chairs were worked out by A. L. Graburn, mechanical engineer of the Canadian Northern, Toronto, Ont.

STEEL FRAME DOUBLE TRUCK CABOOSE

Underframe of Exceptionally Heavy Design; Comfort and Convenience of Crew Carefully Considered

About a year ago the Buffalo, Rochester & Pittsburgh built an eight-wheel steel frame caboose at its Du Bois shops, which was placed in service to thoroughly test the design before adopting it as standard. In preparing the design trainmen were consulted by the mechanical and operating officers in order that everything requisite to the comfort and convenience of the crew might be embodied in the car. The results obtained in service have been highly gratifying and the riding qualities have

been found exceptionally good. The car has a total length over the couplers of 31 ft. 7 in., and has platforms about 2 ft. 2 in. in width. The finished interior has a length of 23 ft. 5 in. and is 8 ft. 4 3/8 in. wide. The car weighs 37,900 lb. Special attention was given to the interior arrangement of the car, which is provided with sleeping accommodations for five persons in three lower and two upper swinging bunks. Two additional persons may also be accommodated in the cupola. The arrangement of the upper bunks is similar to that em-

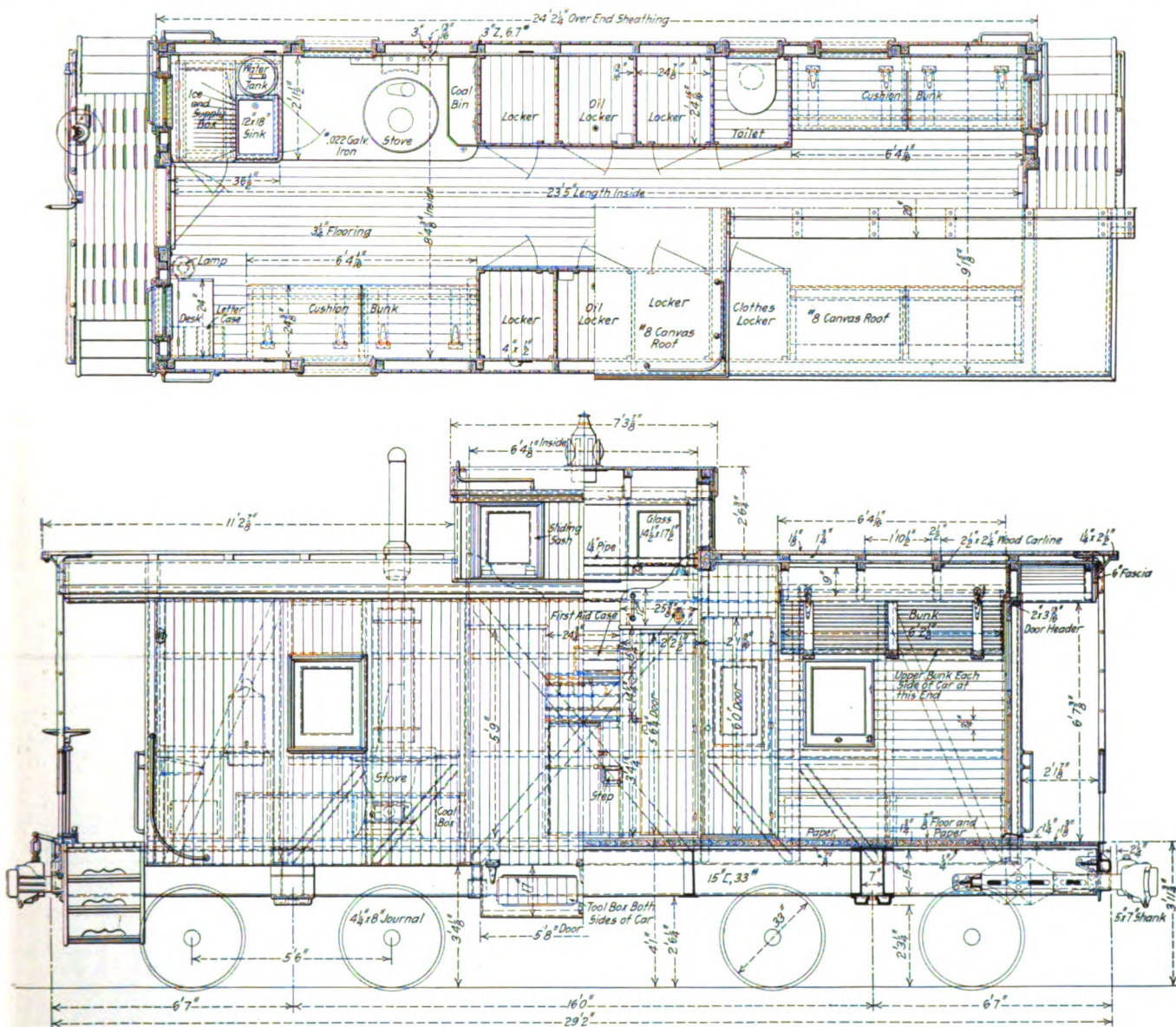

Part-Sectional Views of the Finished Caboose

been found exceptionally good. The car has a total length over the couplers of 31 ft. 7 in., and has platforms about 2 ft. 2 in. in width. The finished interior has a length of 23 ft. 5 in. and is 8 ft. 4 3/8 in. wide. The car weighs 37,900 lb.

Special attention was given to the interior arrangement of the car, which is provided with sleeping accommodations for five persons in three lower and two upper swinging bunks. Two additional persons may also be accommodated in the cupola. The arrangement of the upper bunks is similar to that em-

ployed in sleeping cars; when they are not in use they may be swung up against the roof of the car thus leaving the side windows entirely unobstructed. There is a desk and pigeon holes for letters and other stationery, an ice-box with separate food chamber, a sink, a cupboard and large water cooler, a stove and coal box, a toilet room and lockers for clothing, oil cans and lanterns. Special holders are provided for torpedoes, fuses, lantern globes and markers. A pressure gage is attached to the

UNDERFRAME

The underframe is of exceptionally rigid construction for a car of this nature. The center sills are 15-in., 30-lb. channels spaced 12 7/8 in. back to back and extend continuously between the platform end sills. They are 28 ft. 6 in. in length and are provided with a 1/4 in. top cover plate between points 11 in. back

of the platform ends of the sill. The body bolsters are spaced 16 ft. between centers and are built up of two ¼-in. pressed steel sections with pressed steel fillers between the center sills, and top and bottom cover plates. The top cover plate is of ¼ in. steel 14 in. wide and is 6 ft. 10 in. long. A ¾ in. plate is riveted to the bottom flanges, terminating just outside of the side bearings.

The side sills are 5-in., 11.6 Z-bars, 24 ft. in length, placed with the bottom flanges out. They are secured to the ends of the bolsters and to 3/16 in. pressed steel crossies located 2 ft. 11 in. on either side of the transverse center line. At the ends they are secured to 5 in. by 3 in. by 5/16 in. angles which form the body end sills. The corners of the car body are braced diagonally to the center sill and body bolster by 4-in., 5¼ lb. channels secured flanges downward to ¼ in. gusset plates at either end.

tom of the side plate is 6 ft. 10 in. above the top of the side sill, and it is extended to support the platform roof carlines.

The end panels of the side frame have single 4 in. by ½ in. plate diagonals, the lower ends of which are riveted to the side sills near the corner posts. Two diagonals of the same section are placed in the center panel, which has a total length of 6 ft. 5¾ in. The intermediate panels contain the side windows. They are stiffened below the windows with longitudinal angles and channel diagonals. The angles are of 2½ in. by 2½ in. by ¼ in. section, and are secured to the posts by means of gusset plates, to which the upper ends of the 3-in., 4-lb. channels are also riveted.

The door posts are 3-in., 6.7-lb. Z-bars and are placed to clear 15 9/16 in. either side of the center line. At the bottom

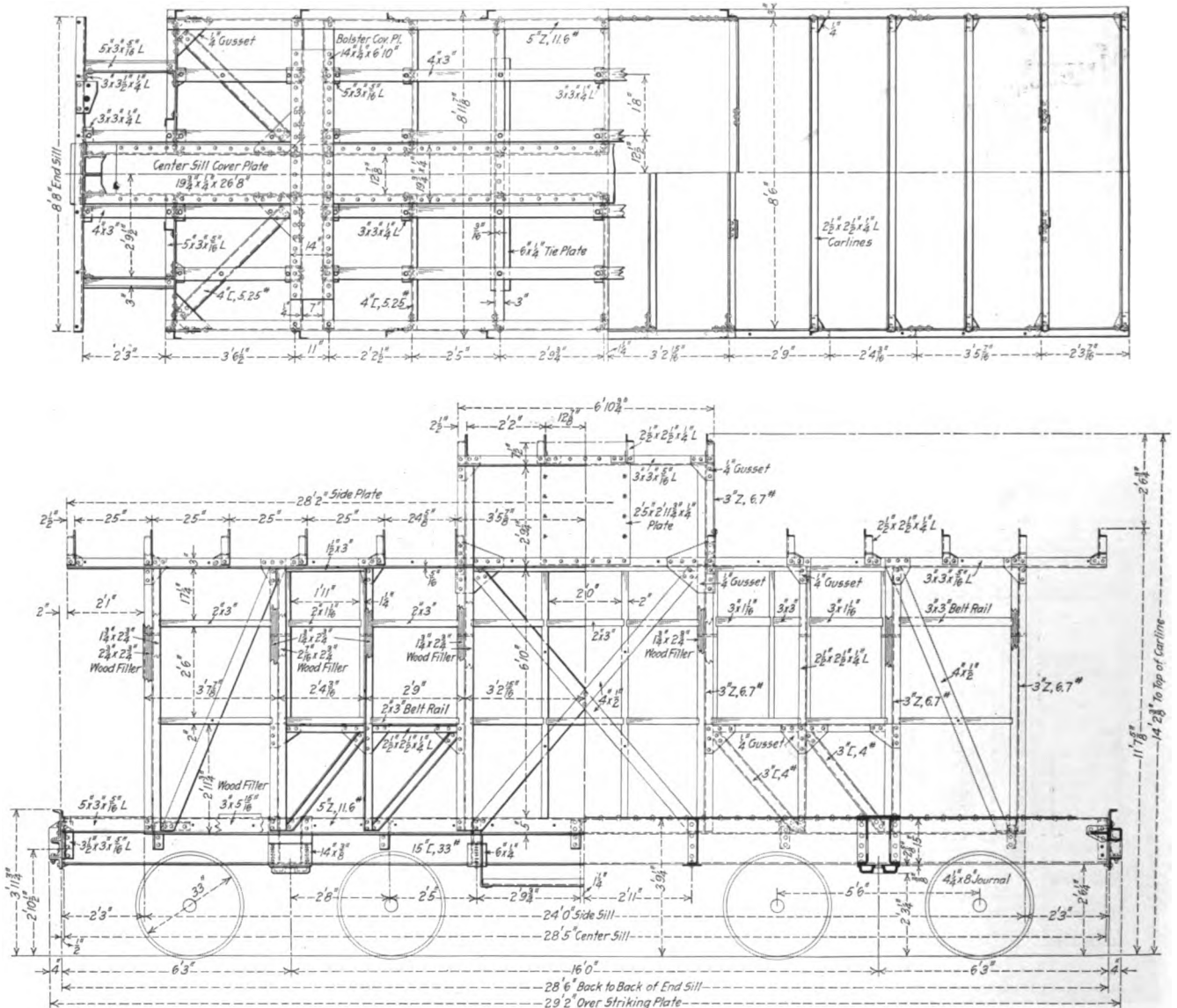

Half-Sectional Side Elevation and Plan of the Steel Caboose Frame

Longitudinal platform sills of 5 in. by 3 in. by 5/16 in. angle section are placed between the platform end sill and the body end sill 2 ft. 9½ in. on either side of the center.

BODY FRAMING

The side frame is made up of seven channels. The corner and side posts are 3-in., 6.7-lb. Z-bars, with two additional posts of 2½ in. by 2½ in. by ¼ in. angles on each side. They are secured directly to the side sills at the bottom, and by means of gusset plates to the 3 in. by 5/16 in. angle side plates. The bot-

tom of the side plate is 6 ft. 10 in. above the top of the side sill, and it is extended to support the platform roof carlines. The end panels of the side frame have single 4 in. by ½ in. plate diagonals, the lower ends of which are riveted to the side sills near the corner posts. Two diagonals of the same section are placed in the center panel, which has a total length of 6 ft. 5¾ in. The intermediate panels contain the side windows. They are stiffened below the windows with longitudinal angles and channel diagonals. The angles are of 2½ in. by 2½ in. by ¼ in. section, and are secured to the posts by means of gusset plates, to which the upper ends of the 3-in., 4-lb. channels are also riveted.

The door posts are 3-in., 6.7-lb. Z-bars and are placed to clear 15 9/16 in. either side of the center line. At the bottom

cupola frame is made up of Z-bar posts and angle side plates and carlines, all of the same section as the similar members of the car body, to which it is secured by means of gusset plates; each gusset is riveted to the body side plate, a body post, a carline and a cupola post.

wood belt rails and vertical nailing strips are set into the frame and the sheathing secured to them.

The floor is secured to 4 in. by 3 in. wood nailing strips,

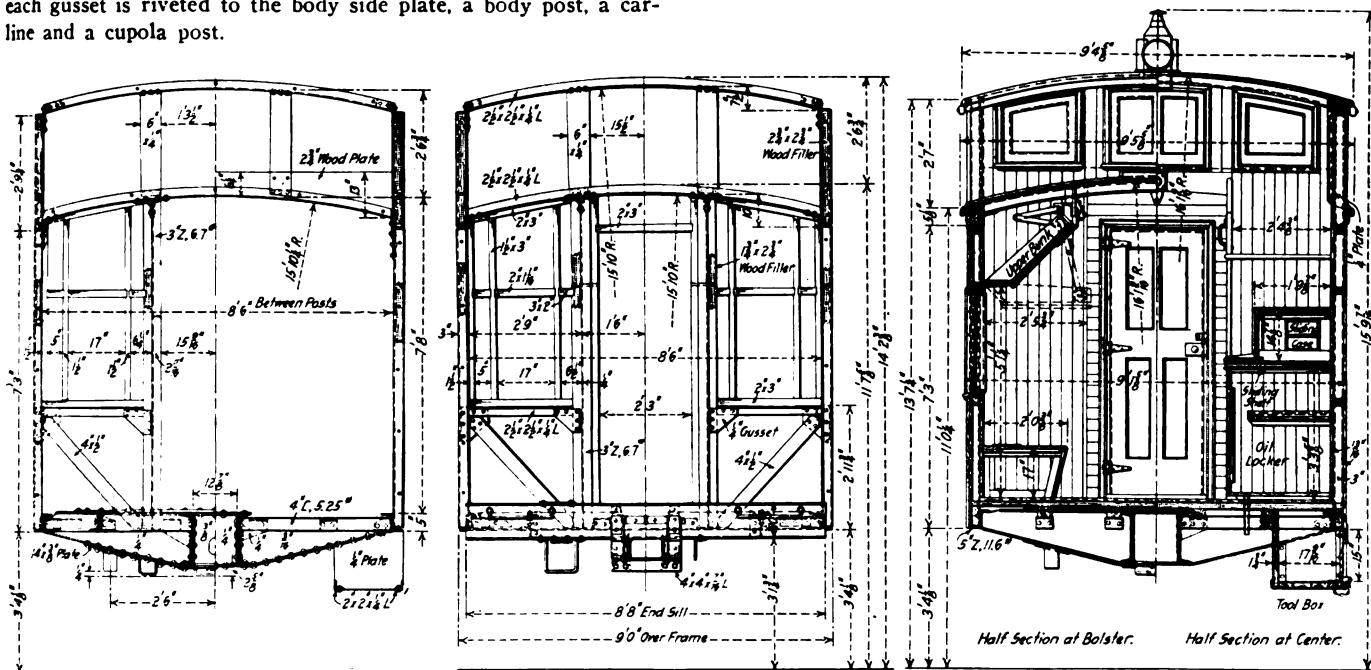

End and Cross-Sectional Elevations Showing the End Frame and Finished Interior of the B. R. & P. Caboose

The sheathing of the car both inside and outside is of wood. The question of finishing it entirely in steel was considered, but wood was finally chosen because of its better heat insulating qualities. As shown in the side elevation of the car frame,

placed 12½ in. and 20 in. from the center line on either side. These strips are continuous between the bolsters, to which they are secured by 5 in. by 3 in. by 5/16 in. angle brackets. They are bolted directly to the flange of the pressed steel crossbearers. Additional support for the floor is furnished by three channel crossbearers on either side, brackets being riveted to them for bolting the nailing strips. Similar nailing strips are placed between the body bolster and the end of the car, those at the center extending through to the platform end sills, while the others terminate at the body end sills. The first course of

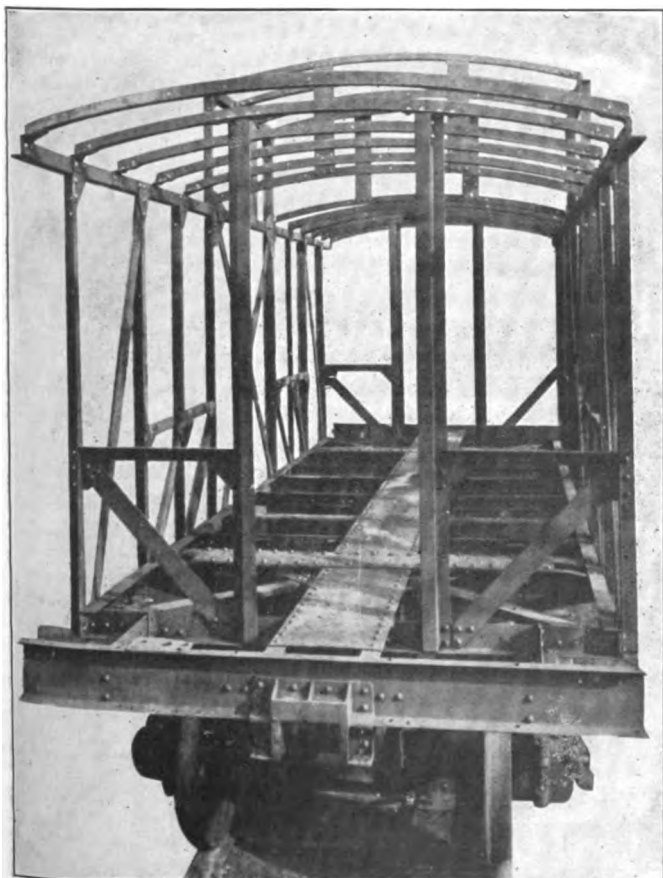

The Assembled Steel Frame of the B. R. & P. Caboose



Steel Frame Caboose for the Buffalo, Rochester & Pittsburgh

flooring is 1¼ in. thick and is laid on paper. Above this is placed another layer of paper on which is laid the top floor of ¾-in. material running lengthwise of the car.

The roof is laid on 2½ in. by 2¼ in. wood carlines, which are bolted to the angle carlines. It consists of one thickness of wood sheathing covered with No. 8 canvas.

Tool boxes are placed under the center of the car on both sides. These are 5 ft. 8 in. in length by 17 9/16 in. in depth by

15 in. in height, and are closed by side doors which are hinged at the top. These boxes have a steel frame made up of 1/4 in. end plates, which are flanged both top and bottom, and 2 in. by 2 in. by 1/4 in. angles. The end plates are riveted at the top to the flange of the pressed steel crosssties and are connected at the bottom by the angles. The bottom and back are closed with 1 3/4-in. plank, the front being closed by the door, which opens the entire length of the box.

In order to secure an easy riding car a specially designed truck has been used. It has a wheelbase of 5 ft. 6 in. The side frames and bolsters are of cast steel and are fitted with long elliptic springs.

PROPOSED GANTRY CRANE FOR CAR REPAIR YARDS

BY W. E. JOHNSTON

Chief Draftsman, Western Pacific, Sacramento, Cal.

Practically all machine, boiler and blacksmith shops are equipped with cranes of various kinds suited to their requirements, but the car repairers still do their hoisting by means of jacks which are comparatively slow and inefficient when the cost of labor to operate them is considered. There is, also, an element of danger always present in hoisting cars by means of jacks because of uncertain footing under the jacks.

The gantry crane described herein has been laid out as a

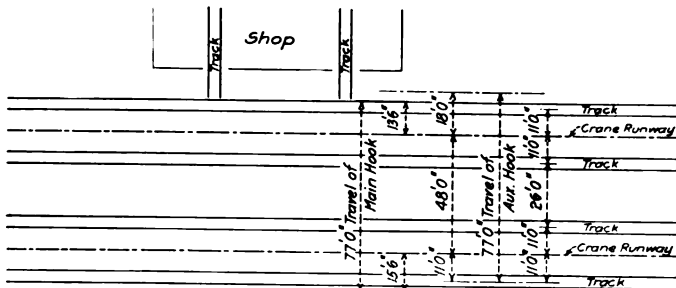

Plan of Car Repair Yard for Gantry Crane Service

suggestion for the provision of the same kind of hoisting and carrying facilities for the car repair tracks that have proved their value on other railroad repair work. The character of the work on repair tracks requires considerable space and the first

trolley with two hoists and should fulfill about the following specifications:

Main hoist, capacity.....	40 tons
Main hoist, speed.....	10 ft. per min.
Auxiliary hoist, capacity.....	10 tons
Auxiliary hoist, speed.....	30 ft. per min.
Bridge travel.....	500 ft. per min.
Trolley travel.....	100 ft. per min.

The main hoist would lift one end of any loaded car or, with proper grappling irons, would lift the entire body of any empty car, thereby eliminating the use of jacks for the purpose of raising the cars for the removal of trucks or for other purposes. The auxiliary hoist is intended for handling trucks, mounted wheels, couplers and other lighter parts.

On the track layout a shop is shown at the side of the tracks near the transverse center line of the yard. This is intended principally for mounting wheels, but could include any other metal working machinery desired for other repair work. By locating the shop near the center of the tracks the average distance traveled by the crane in handling material to and from the shop is reduced to a minimum.

With the crane and runway as shown, a complete truck or any smaller part could be picked up at any point and laid down at any other point within the space served by the crane. This would make it possible, for example, to remove an entire truck from its car and deliver it to the shop, where repairs could be made more conveniently and cheaply than in the yard.

In working out the design of the runway the requirements of safety were kept in mind as well as low cost. A high speed gantry crane running on a track at grade would be dangerous to men working in the vicinity and the crane itself would be liable to derailment from obstructions on the track. With the low runway as shown the rails are at such a height that they will always be clear and there is no occasion for injury to employees. This arrangement leaves the ground clear except for the columns supporting the runway.

SIGNIFICANCE OF THE WORD DRAFT.—The word "draft" as used in describing boiler practice is indefinite. Sometimes it signifies the motion of the gases, but ordinarily it means the difference in pressures which produces the motion. Thus, for example, if the difference in the water columns in the U-tube connected to the breeching is 1 in., the draft in the breeching is said to be 1 in. of water. Actually, of course, the pressure of the gases within the breeching is 1 in. of water below atmospheric press-

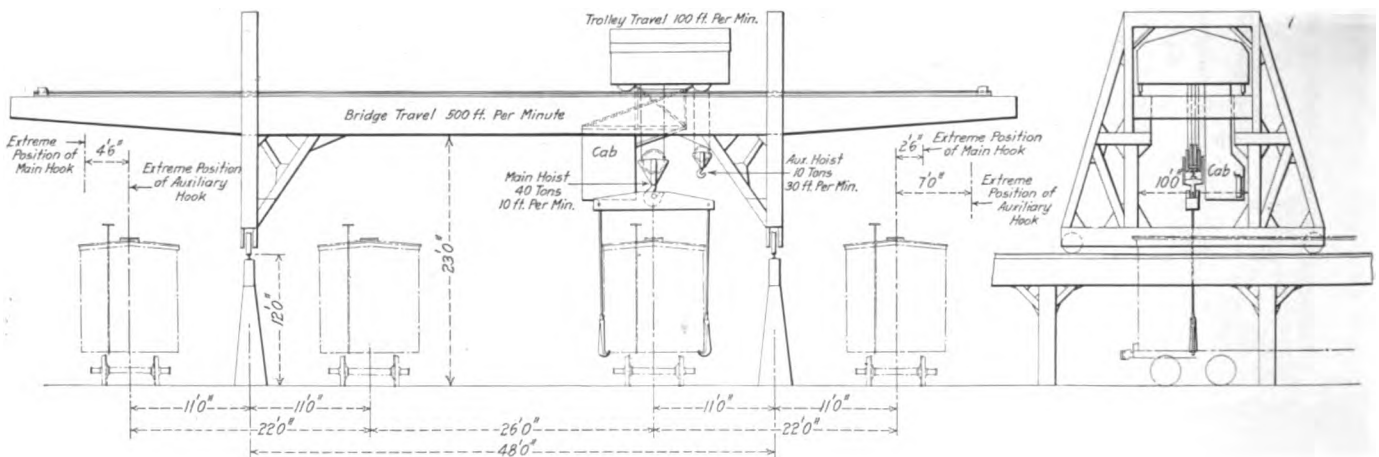

General Arrangement of Gantry Crane for Car Repair Yards

problem is to make the equipment cover a large territory without becoming too expensive. Fairly high speed is essential, also, on account of the distances to be traveled.

The drawings show an arrangement that is believed to cover the requirements satisfactorily and at reasonable expense. The gantry crane with cantilever extensions would have a single

ure. If kerosene is used in the gage the difference in height of the two columns must be multiplied by the specific weight of the kerosene in order to obtain the figures for inches of water. The average specific weight of ordinary kerosene is about 0.78, so that when kerosene is used, if the draft gage indicates 1.2 in., the draft is 1.2 by 0.78, which equals 0.936 in. of water.

SHOP PRACTICE

GREAT NORTHERN RECLAMATION PLANT

The geographical location of a railroad governs to a large extent the practices to be followed in the reclamation of scrap material. Some roads find it to their advantage to concentrate the classifying, reclaiming and salvaging at one principal point on the system, while other roads salvage and reclaim a great amount of material at the various shop points, leaving the classifying to be done at the scrap docks. This latter practice the Great Northern has found it expedient to follow, owing to the number and location of its shops; and its shop men are so trained that but little usable material finds its way to the general scrap docks. Thus it is only necessary to classify the scrap, salvaging what material is picked up from the road, such as track material, wreckage, etc., which is brought directly to the scrap dock.

The bulk of the scrap is received at St. Cloud, Minn., 75 miles west of St. Paul, where it is sorted and held for shipment to the scrap dealers, with the exception of the wrought



Fig. 1—Scrap Pile at St. Cloud

iron scrap, which is salvaged or worked over into first class bar iron in the rolling mill at that point. On the extreme west end of the system the scrap is classified and sold direct to the mills in that vicinity. By following this plan a large amount of cross hauling of the reclaimed material is eliminated, the stores department is relieved of a large amount of accounting, since the material reclaimed is turned directly into the local stock, and the shops receive direct credit for the amount of material they reclaim.

While the company has met with marked success in operating on this basis the chief point of interest is the reworking of the wrought iron scrap at St. Cloud. At this point the company operates a full fledged rolling mill for this purpose, and since it was started in August, 1913, it has reworked all of the wrought scrap originating on the entire system at a substantial profit. During the year 1914 this mill produced 8,863,835 lb. of bar iron, divided into various classes as follows:

Round iron, common	6,326,865 lb.
Square iron, common	42,780 lb.
Flat iron, common	1,852,635 lb.
Deformed iron, common (for reinforced concrete).....	14,505 lb.

Hexagonal iron, refined.....	91,480 lb.
Round iron, refined	507,407 lb.
Flat iron, refined	28,163 lb.
Total	8,863,835 lb.

This was done at a cost of less than 90 cents per 100 lb., on an average, this figure including the cost of the scrap at current prices and all overhead charges, and it is conservatively



Fig. 2—Wrought Iron Scrap Ready to Be Made Into Piles for the Rolling Mill

estimated that a saving of over 25 per cent has been made on the market price of the iron rolled.

The mill is operated as a distinct unit and is under the direct jurisdiction of the superintendent of motive power in charge of shops. All the work connected with it is done on a

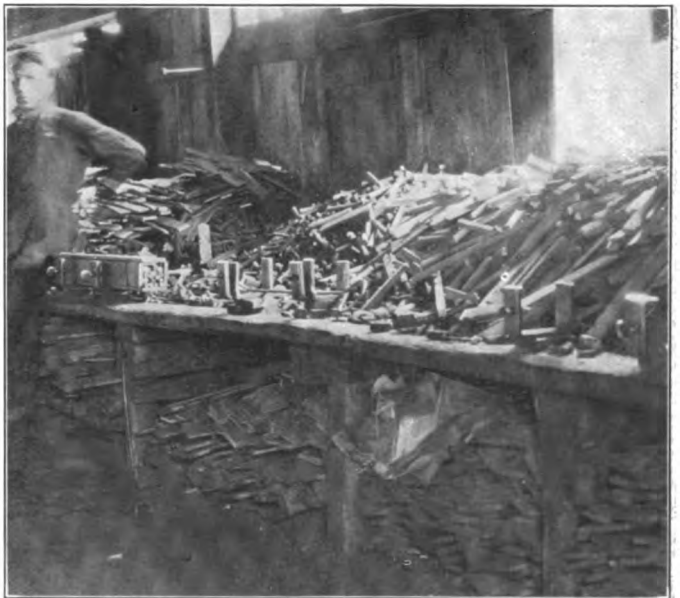

Fig. 3—Piling Bench at St. Cloud Rolling Mill

contract basis, the standard rolling mill scale being followed consistently. The wrought scrap is sold to the mill by the stores department, as to an entirely independent concern, at the prevailing scrap prices, and the mill sells, as it were, direct to the stores department, charging for the material the

cost of production, which includes the scrap cost and all overhead charges. This price is carried in all the general price lists and is changed monthly. As the mill is able to supply the needs of the system there is no confusion with the outside market prices. The work of the mill is done on a shop order basis, the orders being issued by the stores department for a sufficient quantity to warrant the changing of the rolls.

The workmen in the mill are all experienced mill men, it being found quite desirable to obtain them from other mills rather than to attempt to educate the local men to do the work. The force consists of one head roller, who has charge of the mill and with whom the contracts are made, two



Fig. 4—Sheared Wrought Iron Axles Which Are to be Rolled Into Refined Iron Bars

roughers, two stranders, two finishers, one catcher, one hooker-up (these men pass the heated bars through the rolls), two heaters, two helpers, two straighteners, two shear men and four pilers, all of whom are paid out of the contract price.

The scrap as it is received from the system is shown in

against any orders for such material. The wrought iron scrap which is not thus handled is cut to proper length for piling, sorted and delivered to the piling bench. Fig. 2 shows a pile of the smaller pieces just outside of the mill. As it is required it is shoveled through the window onto the piling

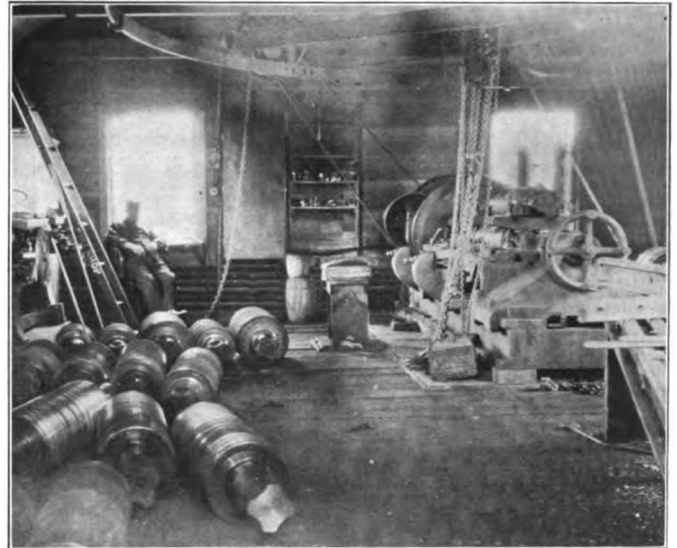

Fig. 6—Shop for Maintaining the Mill Rolls

bench shown in Fig. 3. Here it is made up into piles varying from 75 lb. to 250 lb. in weight. The flat iron is used for the sides and battens of the piles.

The wrought iron axles are sheared to length as shown in Fig. 4. This iron is rolled into what is known as the refined iron mentioned in the output table previously given. It is used for engine bolts, all rivets except those used in boiler work, and such other material as requires a better grade of iron. The iron made from the piles is known as common iron. The piles are heated in two large oil furnaces of the rever-

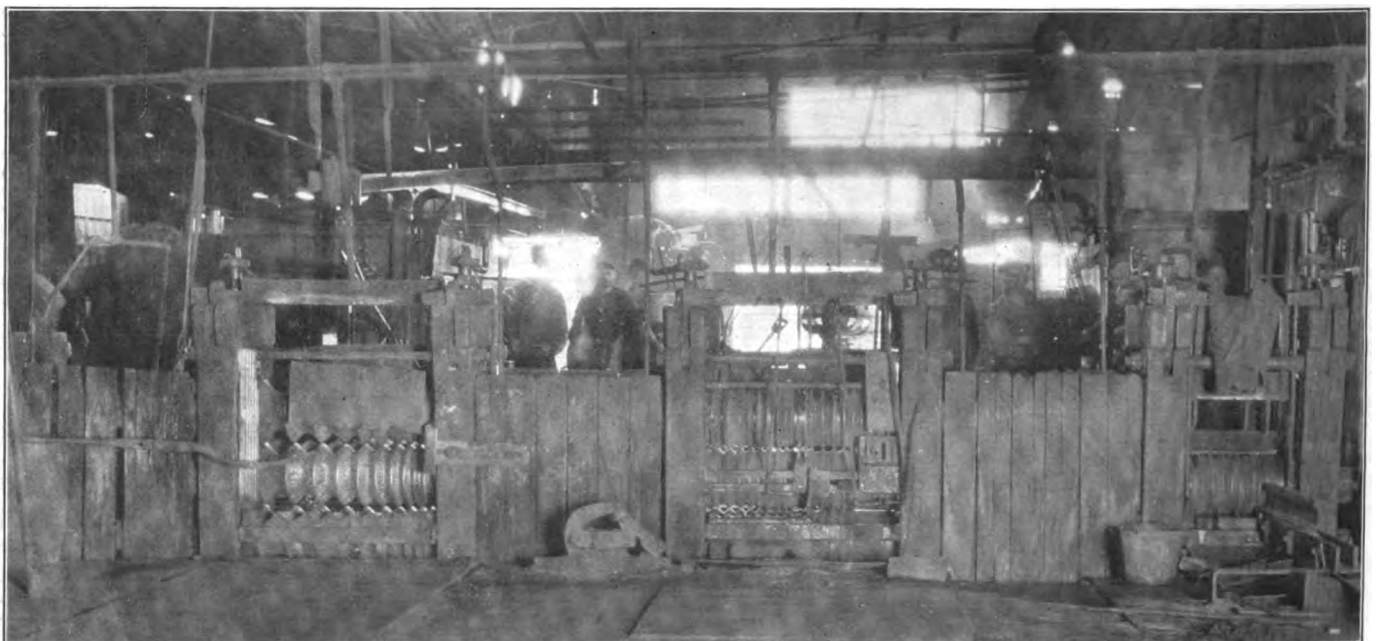

Fig. 5—Rear View of the Rolling Mill; Roughing Rolls on the Left

Fig. 1. It is classified from this pile and delivered to the scrap bins, with the exception of the wrought iron scrap. The rods in good condition and of a diameter generally used at different points are cut to length, straightened and applied

berating type, each having a capacity of 1,900 lb. per heat. These furnaces are located in front of the rolls, one on each side, and each furnace is used in rotation; that is, while one is feeding the rolls the other is heating its charge to the

proper rolling heat. The heated piles are carried from the furnace to the mill, a rear view of which is shown in Fig. 5, by long tongs suspended from an overhead trolley which runs between the two furnaces and the roughing rolls shown on the left in the photograph.

The mill is what is known as a 12-in., three-stand mill, there being three sets of housings. The rolls in the different stands are connected by flexible couplings and the entire mill is driven by a 125-hp. Buckeye engine. The housings of the mill were built by the company and the rolls purchased from the United Engineering & Foundry Company, Pittsburgh, Pa. For the entire work of the plant 44 separate rolls are required. These are maintained in condition by a machinist, a special room being assigned to this purpose (see Fig. 6). The rolls are such that the following sizes of bars may be rolled:

Round iron	½ in. to 1½ in.
Square iron	½ in. to 1½ in.
Hexagonal iron	¾ in. to 1¾ in.
Flat iron	¾ in. to 1 in. by 2 in.
	¾ in. to 1 in. by 1½ in.
	¾ in. to 1 in. by 1¾ in.
	¾ in. to 1 in. by 2 in.
	¾ in. to 1 in. by 2½ in.
	¾ in. to 1 in. by 3 in.
	¾ in. to 1 in. by 3½ in.
	¾ in. to 1 in. by 4 in.
	½ in. by 1¾ in.

In addition to this, deformed iron is rolled for concrete reinforcing bars. All but the ½-in. round iron is rolled to size in one heat. This is made into billets in order to produce the necessary homogeneity of metal for the small bar.

As the finished bar comes from the rolls it is placed on a hot bed. Bars have been rolled as long as 200 ft. The maximum output made by the mill is 75,000 lb. for one day (a day is governed by the run of the heats) and 1,480,000 lb. for one month. The bars are taken from the hotbed while still hot,

the mill occupies a space 250 ft. long by about 45 ft. wide.

With all this material collected at this point it has been found expedient to manufacture bolts, rivets and grab irons at St. Cloud for the entire system. During the year 1914



Fig. 8—Carriage Bolts Made on Automatic Bolt Machines

over 1,600,000 bolts were made at an average cost per 100 lb. of \$1.20 without nuts, this cost including the cost of the iron as produced by the mill, labor and the necessary overhead expense. In addition to this 322,740 ½-in. carriage bolts were made at an average cost of \$1.60 per 100 lb. without nuts. One hundred and seventy-six thousand rivets were also made at an average price of \$1.25 per 100 lb. boxed. This latter



Fig. 7—Storage Yard for Finished Bar Iron

passed over a series of large diameter rollers and cut to length, usually 16 ft., on an alligator shear. They are then weighed on track scales and placed in stock as shown in Fig. 7. The refined iron is distinguished from the common iron by the use of red paint on the ends. Taken as a whole

item alone represents a saving of over 300 per cent. The bolts and rivets under 9 in. in length are made in an automatic Ajax bolt machine which is fed directly from a furnace handling the 16-ft. rods. This machine will produce on an average of 1,500 lb. of rivets per hour and 4,000 bolts. Fig. 8

shows some of the carriage bolts thus made. The bolts over 9 in. in length are made on a continuous motion bolt machine, which will produce 1,200 bolts per hour.

As stated in the first part of this article, the local shops do what reclaiming is possible. For instance, a group of machines is used in the freight car repair shop at St. Cloud for reclaiming the bolts and nuts taken from the cars under repairs. It consists of a four-head threading machine, a small shear and a six-spindle nut tapping machine. Those bolts and nuts that are found suitable for use are placed directly in bins in the shop for immediate use. Those bolts that are slightly damaged are sheared off, rethreaded and placed directly in the available stock, and the nuts that are badly rusted are tapped and also made available for immediate use. Large quantities of bolts are thus reclaimed with all the otherwise necessary accounting and trans-shipping eliminated.

In addition to the manufacture of bar iron at St. Cloud the Great Northern makes all of its heavy bar iron from 2 in. up to 12 in. square for the system at its Dale street, St. Paul, Minn., shops under a 4,000 lb. hammer. The scrap is made into piles of 250 lb. and hammered into slabs and held in stock for shop orders for heavy bar iron. This shop slabs 11,000 lb. per day. In cases of emergency the material is worked into driving axles. The company also maintains its brass foundry at this point, where all the brass scrap is received and used. This foundry provides the necessary brass castings for the entire system and has a capacity of 15 tons.

LOCOMOTIVE BOILER INSPECTION

I don't quite agree with the very optimistic statement made by the chief of the Federal Boiler Inspection Bureau as to what his bureau has done. I hope he did it and I hope he will continue to do it, but there is an old Spanish proverb which states, "What has not happened for two years, may happen in two minutes." And it is quite correct.

The Public Service Commission of the state of New York, whose members have had five years' experience in conducting a locomotive boiler inspection bureau, state in their report for 1913 that they doubt very much the wisdom of continuing the locomotive boiler inspection department, as the officers of the mechanical departments of the railways have so adequately performed their work that they do not see why it is necessary. And then they go on and show a tabulated statement as to the number of accidents before and after—really not before, but the first year, which can be assumed as being before the boiler inspection bureau was established, because any rules put into force had not had time to make a radical change in the conditions that had been in effect—and during five years from 1909, accidents were reported as follows: 1909, 12 accidents; 1910, 11 accidents; 1911, 36 accidents; 1912, 35 accidents, and 1913, 27 accidents. Now I do not for a minute mean to criticize the boiler inspection department of the federal commission. I am well acquainted with a number of the gentlemen connected therewith, and their work has been of the most meritorious character, but it is a question in my mind as to whether the public of the United States has gotten back the \$225,000 paid those gentlemen for performing their work (which they earned) and whether they have gotten back the \$6,600,000 paid by the railroads for improving a theoretical and not a practical condition. Do not misunderstand me; there has been improvement. The question is whether the improvement, or all of it, has been worth while. Another question is whether we cannot accomplish the same improvement with very much less documentary evidence. The Public Service Commission of New York remarked in the 1913 report, "The mass of correspondence reaching this office and the number of reports reaching the office is so great that we could not inspect the boilers."

The Federal Congress at 4 o'clock one morning passed a law

extending the authority of the chief of the Division of Locomotive Boiler Inspection over the entire locomotive and its parts. If the gentlemen who advocated that law know what it means, they know more than any railroad man in the United States.—D. F. Crawford, general superintendent of motive power, Pennsylvania Lines West, before the Pittsburgh Railway Club.

DOUBLE TIRE FLANGING TOOL

BY R. E. BROWN

Machine Shop Foreman, Atlantic Coast Line, Waycross, Ga.

In a large number of shops the driving and car wheel lathes were built before the advent of high-speed steels made necessary by the rigid construction found in modern machine tools. These old machines are too light to permit the use of flanging tools cutting on both sides of the flange at the same time, and the tool shown in the drawing was designed in order that the operator might be able to finish flanges under such conditions

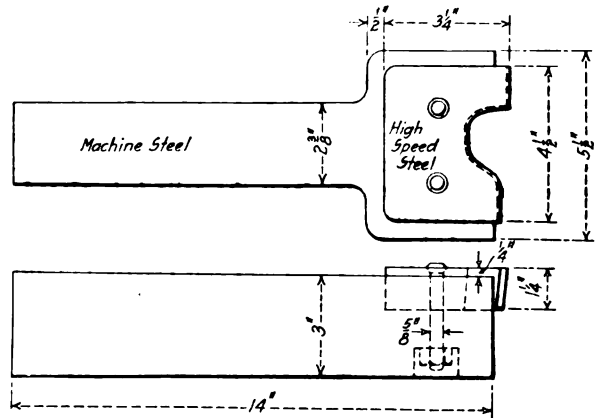

Flanging Tool for Light Wheel Lathes

without removing and replacing the tool holder in the tool post. The contour of the tool is correct for both the inside and outside of the flange, but the opening is widened so that the two parts are separated by about $\frac{3}{8}$ in. After finishing one side of the flange it is only necessary to move the head over $\frac{3}{8}$ in. to finish the other.

STRENGTH OF CAST IRON.—It was pointed out before the Society of Chemical Industry that the strength of cast iron was affected by the addition of wrought iron in the following proportions: With 100 parts of cast iron 10 parts of wrought iron increases the strength 2 per cent; 20 parts of wrought iron increases the strength 32 per cent; 30 parts of wrought iron increases the strength 60 per cent; 40 parts of wrought iron increases the strength but 33 per cent. The maximum result is therefore produced with 30 per cent wrought scrap.—*American Machinist.*

SUBSTITUTE FOR WOODEN PATTERNS.—Some of the objections to wooden patterns, on account of the grain of the wood and the pronounced effects of temperatures, are claimed to be overcome by a composition of three parts starch, one part ground glue and two parts fine resinous sawdust, mixed into a paste by the addition of water. The sawdust should not be added until the starch and glue have been dissolved by the water. After the ingredients are thoroughly mixed, the whole is heated to 190 deg. F. and continued until it becomes a hard mass. It is then allowed to cool, when it is ready for removal from the receptacle. The resulting composition is a strong, hard, horn-like substance that can be machined, sandpapered and varnished the same as wood. It is decidedly less inflammable than the latter.—*American Machinist.*

MASTER BOILER MAKERS' CONVENTION

Oxy-Acetylene and Electric Welding Processes in Boiler Maintenance; Treatment of Feed Water

The ninth annual meeting of the Master Boiler Makers' Association was held at the Hotel Sherman, Chicago, May 25-28, President James T. Johnston, Atchison, Topeka & Sante Fe, presiding.

An address was made by E. W. Pratt, assistant superintendent motive power and machinery, Chicago & North Western, of which the following is a brief abstract: The work of boiler inspection has been carried on and developed by the government with very little opposition. The government inspectors and the railroad representatives have co-operated for the benefit of both and of the public. There were good reasons for some of the railroad legislation enacted during the past years, but the general opinion seems to be that this has been overdone and that the railroads have been exhausted by the excessive doses of correctives applied. They now need a rest.

Statements made before legislative committees as to the millions of dollars involved by certain enactments do not produce any very great effect. On the other hand, a simple statement made before such a committee in reply to a request for detailed information from the general manager on any topic and showing, for instance, that it is necessary for a railroad to haul 4½ tons of coal one mile to pay for the cost of a postage stamp, has a much better effect on the committee and the galleries than many statements in which millions of dollars figure.

Mr. Pratt also mentioned the tendency of politics to become cleaner and the necessity of men in responsible positions, such as occupied by the master boiler makers, taking an active part in civic affairs. Decreasing the revenue of the railroads, coupled with increases in taxes and wages, makes it dependent upon all interested to see that conditions are improved. To this end every man should go to the primaries and see that the proper men are nominated and elected. Keep in close touch with the employees. Be fair and honest with them, for without the support of rank and file no man can secure permanent advancement. Be courteous and considerate, and be as careful as to how a thing is said as to what is said, and the strength of the individual as well as the Master Boiler Makers' Association will be augmented.

Mr. Pratt recommended the use of oxy-acetylene and electric welding machines and urged the necessity of having as many shops and terminals as possible equipped with them. He also directed attention to the necessity of following closely the minute details of boiler work, such as keeping the flues clean; inspecting the beads on flues; boring out flues; inspecting beading tools to see that they are in proper condition; maintenance of arches, ash pans and front ends; watching the tendency of the sheets to corrode at the grate frame and packing the space between it and the sheets with something to keep the ashes out; last of all the advisability and necessity of being courteous to the men.

The treasurer's report showed a balance on hand of \$758.66. The secretary's report was not ready because of illness.

Frank McManamy, chief boiler inspector of the Interstate Commerce Commission, presented a paper in which he called attention to a tabulated statement of the work that had been done in the matter of boiler inspection by the commission during the first nine months of each of the fiscal years, 1912 to 1915 inclusive, with the results that had been obtained therefrom.

While the decrease in the number of accidents, as a whole, and in the number of casualties resulting therefrom, has been remarkable, there are certain types of accidents which show either no improvement or a very unsatisfactory one, thereby indicating that the causes of such accidents are not being given sufficient consideration.

The credit for the results obtained as shown in the percentages does not all belong to, nor is it claimed by the representatives of the government, as it is fully realized that, without the co-operation of those in charge of the maintenance of locomotive boilers, it could not all have been accomplished. The statement has been made in a few instances that the Federal boiler inspectors are not co-operating with the railroads because they refuse to permit defective equipment to remain in service. The purpose, for which co-operation is desirable, is to improve conditions, thereby reducing the number of accidents and it would not be permitted under the law to co-operate for any other. Therefore, to co-operate with this end in view means to be diligent in the effort to discover defects and to require repairs to be promptly made, and it should mean the same thing to the railroads.

One of the causes of accidents, in the prevention of which satisfactory progress is not being made, is arch tube failures. Of course, when we take into consideration the increased number of arch tubes in use, some progress towards preventing failures has been made, but inasmuch as the records show that approximately three out of every four of such failures are due to improper application or failure to keep the tubes clean, the progress made is far from satisfactory and the remedy is, to a great extent, in the hands of the master boiler makers.

Accidents due to flue failures also indicate that, in too many instances, quantity rather than quality is the controlling factor when passing upon the qualifications of the flue welder.

Failure of injector steam pipes is another source of accident in the elimination of which satisfactory progress is not being made.

Without any intention of opening or influencing the discussion of a subject which has not yet been presented to the convention, its importance, due to the disposition to extend its use and the prominent place it is given in the program, will justify making clear at this time the position which has been taken in regard to it. It is the matter of autogenous welding, upon which two committee reports are to follow. While the art of autogenous welding as at present practiced is comparatively new, the number of uses to which it has been successfully adapted indicate its value; therefore, the commission has hesitated to attempt in any way to restrict its use, preferring to allow its usefulness to be developed to the fullest extent consistent with proper condition of equipment. Like many other valuable ideas, some of its over-enthusiastic friends are using it to an extent and for purposes which are resulting and will result in retarding its development and restricting its legitimate field, as it is not a cure all for all boiler ills.

Welding over staybolt heads so they could not be tested, and renewing, in the same way, button heads, which on account of leakage had been heavily calked and could not be kept tight, are practices to which objection has been made. It is also held that autogenous welding should not be used to repair any part of a boiler that is wholly in tension under working conditions. To its proper use on stayed surfaces no objection has been made, for the reason previously stated. There is no desire to hamper, in any way, the proper development of any useful art.

OXY-ACETYLENE PROCESS FOR BOILER WORK

The report, after citing the necessity of having an oxy-acetylene apparatus in the boiler shop, gave a partial list of the work that can be done with it. This list, with the methods used, is as follows:

Welding in side sheets and patches. When welding in side sheets, some boiler foremen make an allowance for contraction

by dropping one end of the sheet, while others get good results by not making any allowance for contraction. The welding in of side sheets, instead of riveting them, has been made a standard practice by some railroads; in fact one railroad is now cutting the side sheets off just above the mud ring and also at the seam at the crown sheet. In this way they save taking out the mud ring rivets and do not disturb the corners. When welding patches in side sheets, good results have been obtained by putting in round or oval shaped patches. Other roads use disk or make box patches for welding. It is necessary to do this to take care of the contraction.

Building up washout plug holes around the firebox or front flue sheet.

Welding cracks in side sheet doors and crown sheets.

Welding up cracked bridges in flue sheets. One method used in welding cracked bridges is to cut out the crack, then hammer the ends of the bridge in and weld. After it is welded and while hot, it should be hammered back straight. This takes care of the contraction. There are some welders who can weld broken bridges without doing this.

Welding seams in door holes instead of riveting or plugging. This is done in two ways; one is to make the lap of the door flange long enough to cover the holes in the back head and weld what would be the calking edge, if rivets were used. The other is to cut the flange in the back head off just back of the rivet holes and butt the door flange to it; then weld it the same as welding in a patch or side sheet.

Welding in tube sheets and door sheets. This is now being done by some railroads; in fact, fireboxes are now being applied and the only rivets used in them are those in the mud ring.

Welding cracked and broken mud rings. The general practice in welding cracked or broken mud rings is to cut a piece out of the firebox sheet, then cut a V-shaped piece out of the mud ring and weld the ring from the top side, although some successful welds have been made by cutting out a V-shape and making the weld from the bottom.

Welding tubes in back tube sheet. The welding of tubes in back tube sheets does not seem to be as successful with oxy-acetylene as with the electric process. It is also slower. Some success has been reported where copper ferrules are not used.

Welding up pits in tubes. Large savings are reported by some railroads doing this.

Welding safe ends on superheater flues. In doing this, two methods might be mentioned; one is to butt weld by placing the flue and safe end in an angle iron, spot weld it in four places, then turn the flue while the operator welds it. The other way is to bell the flue if the weld is made on the firebox end and insert the safe end, leaving a lap of $\frac{1}{2}$ in. The weld is then made at the edge of the flue. If the weld is made on the front end of the flue, the safe end should be belled. This is done so the edge will not obstruct the flow of gases or the flames get under the lap. The claim made for welding flues in this manner is that in case the weld should fail, the danger of breaking off is removed by the lap holding the flue.

Welding up staybolt holes in side and crown sheets. This saves bushing holes and sometimes patching.

Some of the uses for the cutting torch are: Cutting out shell sheets; cutting out firebox sheets; scrapping boilers; cutting out superheater flues; cutting out countersunk rivets; cutting off rivets on shells and mud rings; cutting off staybolts and radial stays; and cutting off staybolt ends for driving.

In order to use the oxy-acetylene process to the best advantage, the shop should be equipped with an acetylene generating plant and piped throughout.

When portable outfits are used, time is lost and it is also necessary in most cases to send a helper with the operator to help with the tanks. When very many welders are used, one good operator should be advanced to chief welder and his duties should be that of an instructor when breaking in new welders, and to see that torches, hose and gages are kept in shape at all times,

and that work is properly prepared for welding, as many failures in welding can be traced to the work not being properly prepared. An accurate check should be kept to show the cost of every job of welding that is done, as there is danger of doing work with the oxy-acetylene torch that could be done cheaper some other way. Men should be picked for welders with care and instructed for a time by a competent welder.

Without going into the chemistry of the subject, it is pertinent to point out that purity in oxygen is of first importance, not only because the foreign matter usually enters to some extent into combination with the metal of the weld, but because the flame temperature is reduced and the rate of welding or cutting is also reduced. Oxygen loses rapidly in efficiency with each per cent of impurity much the same as incandescent lamps lose rapidly in candle power for small drops in voltage.

With reference to the manufacture of oxygen, it was stated that at the present stage of the art, it is unwise for any company to generate oxygen by chemical means unless in some small shop exceedingly remote from any source of supply of commercial oxygen. Because of the occasional polarization difficulties, the manufacture of electrolytic oxygen must be attended by frequent purity tests since the percentage of hydrogen is increased on the oxygen side of the polarized cell. Three per cent of hydrogen renders oxygen unsafe.

The largest producer of oxygen in this country employs the liquid air process. That company is admirably equipped for meeting its customers' needs, since it has 10 plants and 16 warehouses at important cities throughout the country. Any user realizes the value of an unfailing oxygen service represented by numerous charging stations and by hundreds of thousands of cylinders. Since freight charges enter into the cost of oxygen, numerous sources of supply and cylinders of minimum weight are both important factors.

Liquid air oxygen has a very small percentage of nitrogen which, being an inert gas, does not make an explosive mixture with the oxygen, and on that account the liquid air product is absolutely safe. Recent competitive tests in cutting operations have shown liquid air oxygen to be high in efficiency; in fact it invariably demonstrated its superiority over oxygen produced by other systems.

Oxygen cylinders can be brought to the work, but in large shops, or in fact in any shop employing two or more welders it is better to install a pipe line and to discharge a battery of 10 to 20 cylinders into it through one reducing valve. This plan has the advantages, first that the gas is available at numerous points in the shop, and second that the operators lose no time through shortage of oxygen, or through carting cylinders from job to job or to and from the storehouse. A continuous supply of oxygen is a valuable asset in doing long jobs.

Acetylene can be used with perfect safety. In selecting a generator, one should only consider those which have been approved by the laboratory of the National Board of Fire Underwriters. None but carbide to water feed should be considered.

In this country there are two principal classes of generators; high pressure, by which is meant pressure over one pound per square inch, and low pressure, or less than one pound per square inch. All things considered, the low pressure type is the better for railroad work. Some reasons are outlined below:

Low and constant pressure is desirable for safe and economical operation. The Underwriters' rules prohibit pressures, on undissolved acetylene, in excess of 15 lb. per sq. in. Most high pressure generators work up to 15 lb., which is taken as the maximum safe pressure because acetylene is unstable under high pressures and one of the essentials, in fact the greatest essential of safe operation is low pressure.

It is absolutely certain that any shop possessing apparatus generating or storing free acetylene above 15 lb. pressure is courting accident.

In order to obtain high efficiency from blow pipes, steady acetylene pressures are imperative. When a blow pipe has been

adjusted for a given pressure of acetylene, if the pressure changes, then the proportion of oxygen to acetylene is varied and imperfect combustion results; or, in other words, the flame does not remain neutral. A decrease in acetylene pressure gives an excess of oxygen, resulting in a tendency to burn the metal. An increase in acetylene pressure tends to give a reducing flame favoring absorption of carbon by the metal and also, in some cases, causing the weld to become porous.

This is a matter of great importance and wherever blow pipe operators have contended with constantly varying pressures, especially in boiler work where strength of welds is paramount, neither the men nor the process should be censured if failures resulted. If good results were obtained the operators must have been very competent and highly conscientious in their efforts to maintain proper proportions of oxygen and acetylene.

This important feature is mentioned here, in connection with high and low pressure generation, since the former usually depends on a change in the pressure of the gas to actuate the carbide feeding mechanism. Low pressure apparatus, on the other hand, depends for feeding carbide on a variation in the volume of the gas in the holder and in no way on a pressure change. The advantages to be derived from constant pressure cannot be over-emphasized.

A pair of low pressure generators, with a common gasometer discharging to a pipe line is admirably fitted to give a continuous supply of gas so that operations are not interrupted by recharging. High pressure generators do not operate well in duplex arrangement, and when used singly are the cause of much delay and loss in efficiency due to necessity for reheating welds, which have been allowed to cool at the time of re-charging.

It is not wise from the standpoint of safety to truck any form of acetylene generator through a crowded railroad shop. Danger from tipping over, collisions, falling objects, electric wires, portable furnaces, etc., make it much more risky to use a portable generator than to isolate a stationary machine in a small separate building designed for the purpose, and to carry the gas, by approved methods of piping, throughout the shops.

A question might well be asked concerning the attendance expense of the duplex generator. It is very low. In one shop, near Chicago, employing nine welders regularly, one of them tends to the oxygen manifold and acetylene generator. Those duties occupy him, on the average, 1½ hours per working day of nine hours. Therefore the attendance requires 15 per cent of the time of one man out of nine or 1.85 per cent of the total time of all the welders, which is an almost negligible item of expense.

No operating problems are involved, providing the pipe lines are properly laid out and installed, to give safe and economical service, such as hydraulic flash back traps which absolutely prevent fire from traveling backwards through the hose to the pipe line.

Without going into details here, it is correct to state that any shop, regularly employing two or more welders should pipe for both oxygen and low pressure acetylene, rather than to use any form of portable apparatus.

Because of the unstable nature of acetylene under pressure, it cannot be stored in tanks or cylinders like air or oxygen, but must be compressed in receptacles containing fibrous material, usually asbestos and also a liquid known as "acetone."

Acetylene in this form is very useful for lighting purposes and for operating blow pipes at remote points, where pipe lines do not reach and generators would prove too bulky. Emergency work, such as cutting operations at wrecks or occasional jobs at small outlying shops, can best be handled in this way, but it is not advisable for many reasons to regularly use the tanks in shops employing two or more operators.

The main repair shops of railroads owning 150 or more locomotives, should not entertain compressed acetylene installations, simply because the volume of work warrants a generator plant in order that the highest operating efficiency may prevail.

Compressed acetylene costs the consumer from 2½ cents to 3 cents per cubic foot at the blow pipe, when all items of expense are considered, such as first cost, freight, investment, etc., compared to a cost of less than one cent for acetylene from a generator. The presence of the acetone in the cylinders, mentioned above, has an important bearing on operating expenses. Most acetylene cylinders are made in sizes suitable for lighting purposes, where the demand of the burner is much less in cubic feet of acetylene per hour than when blow pipes are used, especially the larger ones, such as used on locomotive work. Consequently when the blow pipe requires from 40 to 60 cubic feet of gas per hour, as on plates ⅜ in. thick and larger, on mud rings, frames, etc., the cylinder is worked beyond capacity, especially if not freshly charged, and there is difficulty in getting ample acetylene for the burner, without drawing out some of the acetone, which has the bad effect of reducing the temperature of the welding flame, thereby reducing the efficiency and raising the cost of doing work. Also the replacing of acetone at the time of re-charging is a factor in the cost of gas.

In the use of the blow pipe, a wide range of welding tips should be provided, not less than ten different sizes, and so designed that an operator can quickly change from one to another. Four sizes of cutting nozzles, at least, should be provided, so that high efficiency may prevail in cutting all thicknesses of metal.

Cutting blow pipes should have an instantaneous lever control of the cutting supply of oxygen, and the preheating jets should be grouped around the cutting jet so that the blow pipe is "universal," that is to say, that no matter in what direction parallel to the surface being cut the blow-pipe tip is moved, a preheating flame will always lead the cutting jet. Unless the jets are so arranged, the operator must keep the axis of his blow pipe in line with the cut and that is extremely difficult on many jobs, such as, for example, in cutting firebox sheets near the corners.

Provision for controlling the size of preheating jets, regardless of the oxygen pressure and size of nozzle, is a recent development in the cutting blow pipes furnished by a large company, which permits the operator to adjust the intensity of his preheating jets to the needs of the work. Varying intensities of preheating flames may be desired even for a given thickness of metal, and for one size of nozzle and oxygen pressure. For example, intermittent cutting, as on staybolts with short cuts and much preheating relative to the length of cuts, requires stronger preheating jets than is needed for a continuous cut on a long sheet of the same thickness. Round surfaces do not preheat as quickly as thin sections or sharp corners.

It is of the utmost importance that a proper filler metal should be selected for welding. Norway iron wire of great purity is best for firebox work and no flux is needed, but it is not the best practice to weld a cast steel mud ring with that metal, which has 48,000 lb. tensile strength, when the mud ring steel probably has a strength of from 60,000 to 75,000 lb. per sq. in.

It is not sufficient to use a "filler" of the same grade as the metal to be welded, or to use one which might seem even better in quality than the object to be welded. For example, any cast iron to be found on a locomotive no matter how good it may be for the purpose it was made, does not make a good "filler" on a casting where it is important to get a clean, strong weld, which works well under a tool. The reason is, that on cast iron work a special alloy "filler" iron containing from three to four times as much silicon as is found in ordinary foundry castings is needed. The excess silicon replaces that of the welded casting, oxidized in the making of the weld, and since the silicon controls, to a large extent, the proportion of combined and free carbon which there is in the casting, it cannot be removed without hardness resulting.

Oxy-acetylene welding, to be carried on with best of success, must include the use of "fillers" and fluxes specially compounded to meet the needs of the different metals to be welded. This ap-

plies to all forms of iron and steel, forgings, plates, shapes and castings, and to copper, brass and aluminum.

DISCUSSION

Attention was, at first, called to the wide range of work that can be done with the oxy-acetylene apparatus in reclaiming old material, such as steel castings, forgings and in cutting up sheets and structural material, after which the discussion was confined almost solely to the consideration of its uses for welding.

Insistence was repeatedly placed on the necessity of having the work done by skilled men, and especially of having the metals hot enough to flow and come together; for, unless they are melted and if the welding material is allowed to flow in before the proper temperature is reached, there will be no weld.

Care must also be exercised to see that the proper proportions of oxygen and acetylene are used. If there is too much acetylene there will be a tendency to crystallize the metal, and if the oxygen is in excess the metals will be oxidized. It is also well to have the sheets brought together and heated to a welding temperature so that they are really joined before putting in the welding material. If this is done there is no reason why from 96 to 98 per cent of the welds should not be good.

As for the vertical cracks that occur it was generally agreed that it had best not be attempted to weld them if they were more than 6 in. or 8 in. long. That is to say this should be the practice in the back shop. Where the work is to be done in the roundhouse so as to keep an engine in service, then longer cracks can be handled, though the work should be considered to be of a temporary character. To this it was objected, that, if it was possible to weld in patches that measured 30 or more inches square, where there was a vertical weld between the old and the new plates, it seemed reasonable to think that a vertical crack of the same length could be welded. Several methods were proposed for avoiding long vertical seams in patches. These were the use of circular or oval patches and the placing of rectangular patches so that the sides should be inclined and thus so that there should be neither horizontal or vertical welds, but inclined ones. The difficulty with the making of vertical welds seemed to lie in taking up the contraction of the plate after the work had been done.

One speaker suggested a method which had been used successfully in caring for vertical cracks, and that was to drill out the crack for the whole length. The crack is drilled out with holes of about $\frac{1}{4}$ in. diameter and spaced as close together as they can be drilled, leaving barely an eighth or sixteenth inch of metal between the holes; then cutting a V in the bridges thus left and welding the whole tight by flowing metal into the spaces thus left open.

As for the location of the work it was considered to be a matter of no importance, except for convenience and rapidity of action, as to the position. Overhead work can be done as well as that which is down.

There was some discussion as to the best methods of holding and placing work to be welded. In this there were two distinct methods that were proposed. One, and that most commonly used, was to set in the piece to be welded and drop it on an incline from one end to the other at the rate of about $\frac{1}{8}$ in. to the foot and then make the weld. The other was the fastening of the piece in the place that it was to occupy. In the first, the dropped end was gradually brought up into place with reference to the other sheet as the line of the welding approached, thus taking care of the contraction that follows the heating of the metal.

Where the metal is fastened it may be tacked in place either by welding in spots along the seam or it may be put permanently in place by putting in all of the staybolts or other connections that are to be used in the completed work. This last received some criticism, but it is being used very extensively on a large road.

With reference to the pressures to be used it was recommended that these should be about 9 oz. for the acetylene and

about 50 lb. for the oxygen. Above all, constant attention should be employed to see that the cones are kept in proper shape.

Of some of the special pieces of work that were cited, that of putting in mud ring corners was one. In this the corner can be cut out and the new piece welded in and the whole of the work done in 11 or 12 hours. Working in the same place the sheet can be cut out around a washout plug and a new piece put in, leaving the condition as good as new and thus overcoming all of the trouble that follows from the corrosion of the sheets at these points. On one road 1,000 mud ring corners had been repaired in this way during the past four years.

Where long seams are to be welded, it is well not to stop the work after it has been commenced until it is finished. It was found that where failures of the welds occurred it was at points where the welding had been stopped at night or noon. It is well, therefore, to see that, when a weld is started, it is finished before the metal is allowed to get cold. To do this it is necessary to employ two welders who will relieve each other and keep the work going until it is finished. As for the rate of welding, it can be done on a half-inch sheet at the rate of about 2 ft. 4 in. per hour. Among the novelties of firebox work that were brought out was that of cutting out the old box without removing the back head and putting the new box in in two pieces and then welding these two pieces together when they were in place. It was stated that 120 staybolts had been cut off in 13 minutes, and from 5 to 8 radial bolts in a minute. In taking out a firebox, the work can be done in one day and the staybolts can be burned off at the rate of from 150 to 200 per hour; welding can be done at the rate of 18 in. per hour at a cost of \$1.50. Some attempts had been made to weld tubes in place, but it was considered advisable to do this by electricity and to always use the copper ferrule.

It was acknowledged again and again throughout the discussion that much of the success of the work depended on the water that was used in the boiler after the work was done. It was recognized that bad water had a deleterious effect on a welded seam just as it has on one that is riveted, and that work that might be considered very good and satisfactory, where the water was good, would not give good results when worked in a bad water district.

Some prices were given for the work; welding can be done at the rate of 2 ft. 4 in. per hour and at a cost of \$1.23. Cutting can be done at the rate of 2 ft. 3 in. per minute and at a cost of \$2.94 per hour. Staybolts can be cut at a cost of 1.8 cents per bolt. A firebox can be cut out without taking out the back head at a saving of \$58 over the method of cutting out the rivets. The cost of labor in one shop for the welders ranged from 20 cents per hour for the man who was new and was learning to 36 cents per hour for the skilled welder.

A model was shown in the form of a completely welded firebox similar to some that are in use on the Lehigh Valley. This box had no rivets in it. The inside sheet was welded at the front to the back tubesheet and at the rear to the back sheet of the firebox. The advantages claimed for this construction were that the box presented a perfectly smooth surface inside and out.

ELECTRIC WELDING IN BOILER MAINTENANCE

It was the opinion of the committee and a number of boiler makers who were consulted, that it is a mistake to weld cracks in fireboxes more than 8 in. long, as it is only a temporary job and gives much trouble; they have to be rewelded often and this should not be practiced in back shop repairs. A horizontal crack can be more successfully welded than a vertical crack, as the expansion of the firebox is more even vertically than horizontally. This is true in welding cracks in the top flange of tube sheets, as horizontal cracks have been welded and known to give good results for engine house repairs, holding up for six and eight months when cracks from tube holes to rivet holes have to be rewelded often.

In getting sheets, patches and cracks ready for welding, the best results are obtained by leveling both edges of the sheets, or cracks at 45 deg., and leaving an opening $\frac{3}{16}$ in., so as to get the weld through the sheets. In building up thin spots or reducing the size of holes, all scale and grease should be removed, as clean sheets insure good welding. All welds should be built up $\frac{1}{16}$ to $\frac{1}{8}$ of an inch.

The chairman of this committee has had unlimited success in welding tubes at the firebox end and at the time of this report, the Erie division of the Northern Central has tubes welded in passenger service that have been running two years and three months.

The welding of tubes, if properly done, will reduce the tube troubles to a minimum. Where tube welding is a failure it is usually due to the use of improper methods.

The tubes should be applied the same as if no welding was being done, except that no oil should be used on the tools in working the tubes, for electric welding is unsuccessful if oil is on the work. The proper way to prepare tubes for welding is as follows: After ferrules are applied and tubes in place, an oil soft soap should be used as a lubricant instead of oil, on the tube pressers and rollers, after the tubes are beaded; rough the sheet around the head with a roughing tool $\frac{1}{4}$ in. wide. This will remove all the scale from the sheet and gives good metal for welding; then heat the sheet with a burner, which will burn up the soft soap, and this will leave the sheet free from grease and the tubes are ready for welding. Any time the sheet gets wet, dry it or leaky tubes will result.

Care should be taken that the voltage is not too high. High voltage makes it easier for the operator, but it is not good for the tubes, as the operator with high voltage keeps the metallic pencil $\frac{1}{2}$ to $\frac{3}{8}$ in. from the sheet and the metal only sticks and does not weld. A voltage of 64 volts, and 125 amperes makes the operator get within $\frac{3}{16}$ in. of the sheet and at this distance a good weld results.

As good results are not obtainable in welding tubes that have been in service eight to ten months before welding, as from welding tubes at the time they are applied. Tubes, if properly welded at the time they are applied, should give three years' service as far as the firebox end is concerned. It pays to weld tubes if only one year of service is obtained as it will eliminate the engine house tube trouble.

The general opinion of the committee is that it is an advantage to use electric welding for side sheets, patches on mud ring corners, small cracks, building up thin spots on sheets and welding tubes, but a disadvantage to weld long, vertical cracks in any sheet where there is expansion and contraction.

DISCUSSION

The discussion was almost entirely limited to a consideration of the welding of tubes, as this was the principal use to which the electric welding was applied. The method first recommended for this was that no oil should be used on the work. The holes should be drilled with soda and a soft soap made of linseed should be used with the expanding and rolling tools.

It was quite agreed throughout that it was not possible to secure as satisfactory a piece of work in the welding in of old tubes that had been rolled and expanded, as it was with new tubes, and that when such tubes were offered it would be better to take them out and weld on safe ends than to attempt to do a permanent job on the old tubes.

It was also agreed that the use of the copper ferrule was necessary, though some objection was raised to this on the ground, not that it had been found to be possible to do without it but that it ought to be possible to do so in order to cut down the expense. If all of the regular work is to be done, what is to be gained by the welding of the tubes. To this it was replied that the work was far more durable and that the greater lasting powers would more than make up for the extra cost.

In welding cracks with the electric process it was recommended, instead of making a complete weld for the whole

length of the crack that the wire be laid in the bottom of the V for a short distance at a time, thus fastening the two sheets together and, then, that the metal should be built up to the full thickness of the sheet. This was not considered essential to success, but it was recommended as being a method that would be apt to give satisfactory results.

One of its advantages is that there will be less trouble with the expansion and contraction of the metal, in that after the first layer has been put in place there is a chance for the metal to cool before the V is built up to the full thickness of the sheet.

As in the case of the oxy-acetylene method the electric welder is used for a great variety of work, though it was not considered to be as economical as the former for the welding of side sheets.

In this, too, a great deal depends on the quality of the wire that is used. A soft pliant wire, for example, does not seem to have enough vitality and is apt to drop off. The best wire is that made from good Swedish iron. Too much emphasis cannot be placed on this, as cracking welds are very apt to result from the use of bad wire. The wire should show a good elongation in the testing machine.

The voltage ordinarily used was from 58 to 64, though it was recommended that as low as 35 should be used with a corresponding increase of the ampereage.

The electric method is used for the welding of the bridges in tube sheets. It was recommended that, for this work, the V's be cut in from both sides and the weld built up accordingly because, by putting the metal in on each side of the sheet, there would be avoided any tendency to warp.

The arc should also be so regulated that the pencil may be held at about $\frac{3}{16}$ in. from the work; if the current is so strong that it can be held farther there will be danger of burning the metal.

Some trouble has been experienced from the cracking of the new sheets of patches near the line of the weld, but not in the weld itself. It was thought that this was probably due to the treatment that the sheet had received or to some defect in the metal itself. For in many cases electric welds have been made that were stronger than the metals welded and when the work was put in the testing machine and broken the failure occurred outside of the weld and in the new metal.

It was largely a matter of what sort of welding apparatus was installed in a shop as to how the work was done. Where there was nothing but an oxy-acetylene plant, then the work was done with that, and where there was nothing but an electric welder all of the work was done with that, except it was generally agreed that the welding in of tubes could be done much better with the electric welder than with oxy-acetylene. Where both plants were available there was a selective process going on and the work best suited to each was done by the respective methods.

BEST STEEL FOR FIREBOXES

The committee in its report declined to make a recommendation and there was no discussion.

UNIFORM RULE FOR LOAD ON STAYBOLTS

The maximum allowed load on staybolts and boiler braces has been fixed by the rules of the Interstate Commerce Commission, hence the committee confined itself to a recommendation as to the diameter of staybolts to be used. This recommendation was made because small staybolts are more flexible and give greater life to fireboxes than large bolts, the first firebox will last longer than the second; the second will last longer than the third. The less life of the second and third firebox is due to the increase in the size of staybolts made necessary by repeated application of staybolts. It was recommended that $\frac{7}{8}$ in. staybolts be applied as a minimum and that 1 in. be the maximum size, and that all bodies of rigid bolts beyond 1 in. be turned down to $\frac{25}{32}$ in. between the sheets.

STANDARD SLOPE OF CROWNSHEETS

The investigations of the committee showed that there was no standard slope for crownsheets, but the recommendation was made that $\frac{1}{2}$ in. to the foot be used, starting at the tube sheet and going back to the door sheet. The camber should be $\frac{3}{4}$ in. to the foot each way from the center.

Sheets constructed in this manner are comparatively easy to keep clean and free from scale and sediment, and will give the best results.

The advantages of a sloping crownsheet are:

First: In case of low water the highest point in the crown-sheet will become over-heated first, and in all probability will let go quicker and do less damage than if it had no slope.

Second: With this slope the heat strikes the crownsheet more uniformly and is more evenly distributed, thereby causing less strain on the sheet and giving greater life to crownsheets and better results therefrom.

Third: There is more absorption of heat units in the front end than in the rear end of the firebox, and more room is allowed for combustion to take place.

Fourth: A greater amount of heating surface can be used at the front than at the rear end.

Fifth: It gives more room for tube spacing in the back tubesheet.

Sixth: It also gives more room for cab and cab mountings.

The only disadvantage of the sloping crown sheet is that in the construction of the crown and side sheets in one piece there is more waste of material.

DISCUSSION

It was brought out in the discussion that it was not necessary that there should be a standard slope applicable to all roads and conditions of service. Each road should be a law unto itself and the slope of the firebox should be made to conform to the maximum grade of that road. The slope should be such that when the engine is on that grade the crownsheet will be brought to a level position.

TREATING LOCOMOTIVE FEED-WATER

The report gave a general review of the situation as to feed-water treatment and called attention to the fact that an untreated water, although low in incrusting solids, may have a decided tendency to cause foaming, when used in connection with treated water; and at the same time cause incrustations of injectors, line checks, and boiler check valves.

While no recommendation to that effect was made, the tone of the report seemed to favor the treatment of water in the locomotive tanks rather than in roadside treating plants.

DISCUSSION

The discussion partook very much of the nature of an experience meeting. It was stated at the outset, that the treatment of water had effected a very considerable saving on the Missouri-Pacific. At Kansas City, where the water is of 36 grains of hardness, the life of tubes when using the raw water was limited to about 10 months, whereas by the use of water treated in a plant, the life had been lengthened to 21 months, while leaks in the firebox and cracks in the sheets had become things of the past. On the Colorado division pitting occurred to such an extent in the tubes that, after cleaning from scale, it was usually necessary to throw at least 65 per cent of the tubes into the scrap. The water also attacked the crownsheet. It has been found that it is not good policy to mix treated and untreated water in the boiler as it is apt to start pitting and other troubles. On the Wichita division, there are no treating plants and the water is treated with soda ash in the tanks, and here, too, the life of the tubes has been increased from 9 to 14 months. However, it is generally recognized that it is not desirable to use the boiler as a treating plant and that the work had best be done before the water is put in the boiler.

This attack on tubes by the water of the Colorado division was

not due to the kind of tube used, as experiments had been made with every tube on the market, the results all being the same. In these bad water districts it is necessary to wash the boiler out every 400 miles.

Another speaker stated that the use of soda ash had made it possible to extend the period between washouts by 33 per cent and that there had been no bad effects noticed as the result of the soda ash treatment.

One representative had had an extended experience with the use of polarized mercury and he found that the period between washouts could be extended by about one-third. He had found that there is considerable difference in the manner of the circulation of the water when used in boilers having long tubes from what it is in those with short tubes and that this circulation is much freer with the latter. Polarized mercury does not create any tendency to pit, nor does it produce any galvanic action, and when it is used the tubes have a life of about two years and seven months, possibly a little more. Put in figures of miles run this means that the tubes have a life of about 120,000 miles, whereas, before this, they were sometimes limited to 17,000. There were records of a tube life of 147,000 and even 262,000 miles.

In another case it was found that the failures of tubes as indicated by cracking had greatly decreased after the introduction of soda ash treatment, while the number of burst tubes had greatly increased, as the soda treatment seemed to have increased the tendency to pit.

There was a marked difference in the action or apparent action of locomotives fitted with superheaters from those using saturated steam. With the latter, when the tender treatment had charged the water up to the foaming point the foaming was very evident, but in the case of the superheater locomotives, considerable foaming could apparently occur and the water that was carried over into the superheater pipes would be dried out and be delivered to the cylinders in the form of steam.

There was some evidence given to support the idea that the use of soda ash tended to cause pitting, though there were a number of speakers who stated with great positiveness that they could not detect any such tendency.

It was also agreed among those who had had any experience in the use of pure water, such as water that had been treated to a condition of purity, or rain water, that such waters did have a tendency to produce pitting.

CROSS STAYS IN FIREBOXES

In the Belpaire firebox, and some designs of crown bar fireboxes that have flat or nearly flat surfaces where sheets converge from the side to the roof, it is necessary that they be properly braced with cross stays. In this construction, however, there is a considerable distance between the connections of the firebox staybolts to the roof sheet and the necessary slings, braces or stays in the crownsheet, which permits of a certain flexibility that will allow some adjustment to take care of the stresses which are the result of the greater expansion of the side sheets of the firebox under the high temperature of direct contact with the fire, as compared with the expansion of the outside side sheets.

The radial stay boiler, however, should have a circular cross section above the crownsheet, and the use of cross stays in this type of boiler restricts the proper equalization of stresses, which result from the unequal expansion of the firebox, as compared with the roof sheet, which, in the case of radial stay boilers, has practically a continuous connection through the staybolts and radial stays. It is believed that a rigid cross stay above the crownsheet in a radial stay boiler increases the bending stress in radial bolts at about the line where cross stays are applied. Breakage of radial staybolts, in the zone indicated, has been experienced, due to the presence of cross stays in this type of boiler, and when their use was discontinued no further trouble from this cause was apparent. The committee does not consider

cross stays in the radial stay boiler desirable or necessary, provided the boiler is properly designed with a circular cross section.

In conclusion, it was stated that although the cross stays are necessary in the Belpaire and other fireboxes having flat surfaces, they necessitate the use of extreme care in washing the crown sheet, owing to the numerous interstices between the cross stays and crown bars or sling stays, in which mud and scale collects and becomes difficult to dislodge.

DISCUSSION

From the tone of the discussion it would appear that it was a matter of indifference as to whether cross stays were used on some classes of boilers or not. On the old crown bar boiler where the stays ran between the crown bars they were a necessity where there were any flat surfaces, but they have been removed, without trouble resulting, from boilers where the roof sheet is a true circle from the top rows of regular stays. In the case of the Belpaire boiler, where there are flat surfaces, it was agreed that the cross stays are required. It was assumed as a general opinion that it was a matter of local conditions, depending partly on the quality of water that was used, as to whether cross stays should be used or not, always excepting the presence of flat surfaces.

REDUCTION OF STRENGTH IN CORRODED OR PITTED BOILER SHELLS

An examination, supplemented by drilling at what appears to be the thinnest part, should be used to determine the thickness of the sheets, and in no case should the boiler be allowed to pass without repairs if the percentage so found has approached closely to that of the joints carrying the same strain.

DISCUSSION

It was suggested, inasmuch as there is no law or generally accepted practice in this matter that the marine regulations should be adopted, in which the thinnest part of the sheet is the controlling factor. It was also suggested that the age of the boiler should be taken into account in determining the reduced percentage of strength that should be allowed and the practice of the Pennsylvania Railroad was cited as a case in point. On that road the factor of safety is made 4 for the first five years; from 5 to 10 years it is $4\frac{1}{2}$; from 10 to 15 years it is 5; from 15 to 20 years it is $5\frac{3}{4}$; from 20 to 25 years it is $6\frac{1}{2}$; from 25 to 30 years it is 10 and at the age of 30 years the boiler is scrapped.

CONSTRUCTING LOCOMOTIVE TANKS

The report consisted of a brief review of the steps to be taken in the construction of a tank of the ordinary type with a mere reference to the circular tank of the Vanderbilt type.

DISCUSSION

The only thing of any moment that was brought out in the discussion was the description of the new type of tank construction used on the Lehigh Valley. Here, instead of using the usual angle for connection between the sides and bottom of the tank, the latter is flanged upward all the way around and the side sheets are rivetted to it. This does away with the rivets in the bottom and there are none below the ones that hold the sides in place. This does away with the trouble with leaks in the bottom seams and the necessity of lifting the tank from its framing in order to make repairs at that point. Rivets $\frac{5}{8}$ in. in diameter are used, spaced at the regulation pitch, and the joint is made up with a tar paper packing in the usual way. There is no calking and the steel used is tank steel.

DRIVING STAYBOLTS

The objection to driving staybolts with pneumatic hammers and holding them on with a hand holding-on bar is that the vibration of the holding-on bar, when a pneumatic hammer is used, is such that a number of blows are struck by the hammer while the holding-on bar is rebounding; therefore the bolts are

not properly upset in the holes, and naturally the method does not make a good tight job.

To drive staybolts or radial stays successfully with air tools, it is absolutely necessary to hold them on by the same process; the trouble is not in the driving of the bolt any more than it is in the improper methods of holding-on.

In driving these bolts, use a set slightly higher in the center than on the edge, with a small radius on the outer edge, and a staybolt set made especially for this work. This set is used on the inside, as well as the outside end of the bolts; this cuts off all the ragged particles that may be around the edge of the bolts, making a smooth job, which is less liable to gather any accumulations of foreign matter. This work is done with a No. 90 air hammer, and held on with air holding-on tools, made especially for this class of work. In some places a set is used with a center tit to drive the bolt on the outside. This is done where the tell-tale holes are put in staybolts before the bolts are applied. The tit is inserted in the tell-tale hole so as to keep the set centered on the bolt as well as to keep the tell-tale holes in the bolts from being closed up; this is also a very successful method, but some prefer to apply the bolts and have them driven solidly in the center, before the tell-tale hole is drilled. Either one of these methods is good practice.

The trouble with leaky staybolts is not always due to the improper driving, or methods used in driving. There are quite a number of other reasons that contribute directly to these troubles, and if not properly taken care of, the bolts will leak and give trouble, no matter by what method they are driven or held on. It is absolutely necessary to have good threads in all staybolts, as well as radial stayholes, and a full thread on all bolts. It is necessary to have bolts fit the hole properly. If the staybolt and radial stayholes are properly tapped, and the bolts have first-class threads, and are properly fitted to the holes, three full threads will be sufficient to make a good serviceable head.

The report closed with a recommendation to use a longstroke air hammer for the work.

DISCUSSION

The emphasis placed on the driving of staybolts by nearly every speaker was to the effect that the driving should be so done that the metal is spread in the thread so that this is made tight, and the driving down of the edges to form the head was a matter of secondary moment. The discussion started with the question as to whether the bolt should be cut off square or left with a slight bevel, on the ground that, with the latter, the driver would be more apt to strike the bolt in the center and thus upset it than if it were to be cut off perfectly square, when there would be the temptation, especially on piece-work, to simply hammer down the edges. This will make a joint that will pass inspection and stand the water test, but as soon as the engine is out on the road the bolts will loosen and there will be a leak unless it is well driven out in the threads.

It was apparent that it depended more on the way in which the work was done, that is its thoroughness, than on the particular method pursued. One speaker had had experience with all methods, from the hand hammer to the air hammer and the "double gunning," as it is called, where the two ends are driven at the same time with an air hammer at each end. In every case he had found that satisfactory work could be done. But it was urged that in the case of double gunning the men should be familiar with each other's methods and should work in unison, otherwise there might be faulty work done.

The use of oxy-acetylene for cutting off the bolts seemed to give the best satisfaction. It puts no strain on the bolt, the heat does not penetrate the sheet so as to cause any trouble in that way and it is exceedingly rapid, as many as 350 bolts being cut in 45 minutes. The length of the head that is to be left on was recommended to be from $2\frac{1}{2}$ to 3 threads in length.

The cutting of good threads was especially insisted upon. If the thread does not fit it will be impossible to get a tight bolt

and the work of cutting these threads should not be given to an apprentice but be done by some one who knows what is needed and will see that the work is properly done. The cost of cutting off a set of bolts with gas was placed at \$14, as against about \$13 with the hammer, and the latter would be sure to loosen many if not all of them.

REMOVING AND REPLACING FIREBOXES

On the different classes of boilers on the Santa Fe, there is an extra back end suitable for interchange so that when an engine enters the shop, the back end can be cut off and the extra back end complete with new firebox applied, holding the engine not to exceed ten days. This method has a new back end in reserve for interchange, and has proved a paying proposition.

It is not necessary to remove the frames or break the connection at the smoke box on engines of the modern type whose firebox is directly over the frames. Experience has also taught that it is a more expensive method to cut the back end and door sheet loose, in order to avoid cutting away at the connection.

In some cases where the O G box passes through the frames, it is customary practice to separate the boiler at the smoke arch and have the work done in the boiler shop, going over the machinery while the boiler is receiving a new firebox. Otherwise it is simply cut off and modern back ends replaced in the manner described.

It costs at the Topeka shops from \$650 to \$900 to put the firebox and back end in first-class shape, depending solely on the size of the boiler. Where the fireboxes are interchangeable, it is not necessary to bring the boiler to the boiler shop, but simply put it in the rear of the file of engines to be turned out of the shop during the month.

The way in which the work is done must be governed largely by the facilities of the shop doing it.

Where there are proper lifting appliances and the erecting shop space, it is more economical to lift the boiler from the frame and send it to the boiler department and the frame to a department for necessary repairs. This will give a track in the erecting department to repair another engine while the boiler and frame are undergoing repairs.

This was accompanied by a comparative statement of the cost of removing the boiler and of simply raking out the back head, which was as follows:

Total cost of removing back head.....	\$29.35
Total cost of removing boiler.....	22.31
Amount saved by removing boiler instead of back head.....	\$7.04

This is calculating the cost of putting in the firebox the same in both cases, but it would be slightly higher with the boiler on the frames.

The following statement was also given as to the exact cost of renewing a firebox in the boiler of a Consolidation type locomotive, having 413 2-in tubes, 1,065 staybolts, 315 crownbar bolts, with Tee bars and mud-ring 66 in. by 108 in. inside:

To remove and replace firebox by cutting butt at connection, \$700; by cutting boiler off at smoke arch and removing from frames, \$650; by taking out the back head, \$775.

One contributor to the report suggested that, when the shop is cramped for room, boilers can be cut off at the connection, as the cost of removing the steam pipes to do this about equals the cost of the boiler job. He advocated removing the back head for the renewal of the firebox only when there were no crane facilities for handling the boiler and butt end.

DISCUSSION

The discussion centered around the variations in the methods of removing and replacing the firebox without cutting out the back head, and this was the method in general that was used by the speakers with one or two exceptions. In detail, the work was done by cutting off all the staybolts and cutting up the inside sheets with a torch, merely leaving two staybolts in each piece that were cut off, to hold it in place until all of the work was done, and then cutting the pieces loose and allowing them to fall out. The work can be done with the boiler either in the

frames or removed. Sometimes the firebox was burned out as a whole and dropped down; sometimes the boiler was turned upside down and the firebox lifted out. In some cases the firebox was put in intact and rivetted in place; in others it was put in piecemeal and sometimes each sheet was put in by itself and fitted and rivetted. In other words the new firebox was built in place. It seemed to make no difference whether the firebox were of the wide or narrow type, it is well to cut it out without removing the back head.

Some of the speakers make a practice of cutting away the connection between the boiler shell and the firebox and taking the back end to the boiler shop for repairs and either putting in another back end while the one removed is being repaired, or repairing it and rivetting it back in place. This method was criticized on the ground that the rivet holes between the shell and the back end might not come fair in case the latter is changed. This would be apt to be the case, where engines were received on different orders; for while all the engines of one order of a given class would be apt to have the holes laid out so that they would be interchangeable, the same class of engines on another order from the same builder might have the holes so laid out that they would not match. For example, in one case the layer-out might put the outer rivet hole in the center and another put the inner holes in that place. This was accepted as a fair criticism and it was acknowledged that great care had to be exercised to see that holes were true before any attempt could be made to use interchangeable fireboxes.

The question was asked as to how a firebox with a combustion chamber should be treated whose crown sheet was continuous and ran out to form the roof of the combustion chamber. The reply was to the effect that, in most boilers of that class, the sheet of the combustion chamber was welded to the crown sheet and it was only necessary to cut it off at the weld and after it had been replaced make the weld again along the same lines and the boiler would be put back in its original condition again.

In the matter of time required under these methods for the replacement of the firebox, from 16 to 18 days was given. Cases were cited of the replacement of the firebox for a heavy Mikado in 18 days; of putting in one for a Mallet in 16 days; of doing the work on a passenger locomotive whose type was not specified in 10 days and of one case where, on a hurry job, an engine was received in the shop on Monday morning and on Saturday morning it was ready for firing up. These were all working days of 8 hours each.

In all of this it was recognized that the precise method in which a piece of work could be best done was a matter of local conditions and facilities.

In the matter of making partial repairs, this method was criticized on the ground that it was not profitable to put in a half side sheet on each side and possibly a part of a door sheet, or make a similar set of repairs on a firebox, when for a little greater expense a whole new firebox could be put in. It left a part of the structure nearly worn out with a lot of new material that could have been more economically used in the construction of a new box.

OTHER BUSINESS

The secretary's report showed that at the beginning of the year there were 419 members in good standing, that there were 77 new members taken in during the year and that there were 125 of these who were dropped, resigned or had died, leaving a present membership of 371.

The following officers were elected for the ensuing year:

President, Andrew Green, general foreman boiler maker, Big Four, Indianapolis, Ind.; first vice-president, D. A. Lucas, general foreman boiler maker, Burlington, Havelock, Neb., second vice-president, John B. Tate, foreman boiler maker, Pennsylvania Railroad, Altoona, Pa.; third vice-president, Charles P. Patrick, Erie Railroad, Cleveland, Ohio; fourth vice-president, Thomas Lewis, general foreman, Lehigh Valley, Sayre, Pa.; fifth vice-

president, Thomas F. Madden, general boiler inspector, Missouri-Pacific, St. Louis, Mo.; secretary, Harry D. Vought, 95 Liberty street, New York City; and treasurer, Frank Gray, 705 W. Mulberry street, Blomington, Ill.

RECLAMATION OF MATERIAL

A report of the proceedings of the Railway Storekeepers' Association convention will be found in another part of this issue. The following is an abstract of the report of the Committee on Reclamation of Material:

The committee finds that a great deal has been accomplished in the reclaiming of material and also that there is much more to do than has been done. The work needs much systematizing, intelligent supervision, more efficient methods and machinery, and more education of the users of material as well as the reclaimers. There is a vast amount of money tied up in material in store stock under the supervision of the storekeepers, as well as money spent for purchases, which we are responsible for. How much can we reduce purchases and the amount of money tied up in stock material by more efficient reclamation, is the problem which we, as storekeepers, must solve.

The committee believes both purchases and stocks can be reduced materially by reclamation work. The reclamation of material should be under the supervision of the store department for the following reasons:

(1) The store department supervisors are already trained for the work.

(2) The assembling of reclaimed material, its classification, disbursement and accounting is directly in line with good storekeeping.

(3) Centralization of all discarded, second hand, obsolete and scrap material at designated scrap yards under the store department has been found by actual experience to be the best method. The handling of reclaimed material is store department work, as it already has the organization to reclaim that which is fit to use for the purpose originally intended and can easily supervise the work necessary to make reclaimed material into any shape desired. The store department knows what material cannot be reclaimed for any use and will quickly turn this into money to the best advantage.

(4) The store department has adequate records, showing amount of material used, knows how much of each kind to reclaim and will prevent big losses resulting from reclaiming more material than is needed. The store department will also prevent working over material that is not needed.

(5) The store department is in constant touch with the markets and knows at all times the different costs of all articles.

(6) The store department is not only interested in the use of material, but is interested in its abuse. Reclaiming material often shows where there has been abuse, and the store department is in the best position to stop abuse, as it is vitally interested, being measured by the purchases which the abuse increases.

(7) The store department labor force and handy men can do the work cheaper than any other department, as it is necessary for the other departments to do reclamation work in connection with their regular work, which requires high paid mechanics and skilled labor.

There can be no set rules or regulations to cover reclamation work, as the conditions vary so much that each individual case will have to be decided upon its merits. The committee finds, after careful investigation, that the railroads should build and equip efficient reclamation plants (these to be worked up gradually as the needs demand) to handle a large part of the reclamation work, if the best results are to be obtained.

The geographical location of the road, location of shops,

scrap market, traffic tide, etc., should govern the location of a reclamation plant and scrap dock. It should be such as to save back haul of scrap, and at the same time give a minimum haul for reclaimed material and be a good distributing point. Of course, the present location of the scrap dock, size of shops using reclaimed material, land, tracks and buildings obtainable for reclamation work will have to be large governing factors in the location, as well as the size of the appropriation obtainable for this work.

Care must be exercised to see that the plant is so located that there will be room for future growth.

The size of the plant, of course, will govern the organization. The committee recommends that the reclamation plant and scrap dock be under one general foreman, whose rate of pay should be from \$100 to \$150 per month, to whom should report the foreman of rolling mills; foreman of scrap dock (rate of pay \$70 to \$90 per month); leaders (about one for every six laborers), 17 cents to 35 cents per hour; clerks; piece work inspectors; handy men for operating machines and doing special work (16 cents to 30 cents per hour), and laborers (at labor rates).

The leaders or gang foremen should be carefully selected and trained in their duties. By having leaders it only makes it necessary for the foreman to educate them and hold them responsible for work under their supervision, and then they in turn can educate the men.

The number of clerks and the rate of pay will depend on the size of the plant and work necessary to be done.

Handy men or operators should be used in reclamation plants instead of mechanics and journeymen. Much of the work of the reclamation plant is a growth of that formerly done on the scrap dock. Practically all of the work requires but one operation.

All work in the reclamation plant and on the scrap dock should be done piece work and all day work eliminated.

The size of the plant will depend on the size of the road, the number of plants on that road and the location and space available. The plant should be large enough to prevent congestion and so it can be arranged to handle material at the minimum cost. It is a mistake to build a plant, or any part of one, without a complete, comprehensive plan. Many of our reclamation plants are poorly laid out.

The machinery, tools, etc., will have to be selected to meet individual needs as well as the appropriation available. Second hand machinery and tools can often be used to good advantage, but in most cases discarded machinery and tools have outlived their usefulness and are expensive at any price.

[A list of machinery, tools, etc., for a fully equipped reclamation plant was here included in the report. The costs given were for a guide only.]

The cost of reclaiming is the governing factor as to whether material should be reclaimed or not. In arriving at this cost all the factors should be taken into consideration; cost of handling, cost of actual work of reclaiming, interest, depreciation, etc., on the facilities which it is necessary to install to reclaim material and life of the material after it is reclaimed as compared with new articles. In many cases in reclaiming material we deceive ourselves by not taking all of the factors into consideration. What is possible to reclaim at a profit on one road is not on another, but there are a large number of items that it pays to reclaim on all railroads. In starting reclamation work, such articles should be reclaimed as valves, bolts, brakebeams, couplers, bolsters (welded with oxy-acetylene), bar-iron, etc., and then work into the other items as fast as facilities can be installed to reclaim them at a profit.

Material should be classified in accordance with the Railway Storekeepers' Association classification of material, and should be carried in these classifications as recommended in the Book of Rules and distributed and handled similar to store stock. Material should be shipped direct from the

reclamation plant wherever practicable; local conditions and shipping facilities, of course, will govern.

The cost of the plant will depend entirely on its size and the amount of work necessary to fit it for the work required. Wherever buildings are obtainable that are suitable for the work they should be used. However, railroads often lose sight of the savings that might be effected by having a plant built and arranged so that the cost of the work will be reduced to the lowest possible limit. The difference in cost of operation of a plant properly laid out and constructed and equipped with labor-saving devices, and one poorly laid out with inefficient equipment, will often pay for the improved plant in less than a year.

One of the strongest arguments against a reclamation plant is that there should be no need for one. It is claimed by many that material should not be allowed to get where it is necessary to reclaim it, and that by proper supervision and use of material there is no reason for a reclamation plant. However, experience shows that there is need for one.

Prevention requires the education of the users of the material by the men in charge, and by the store department. The storekeeper must watch issues of material and call attention to all cases where the old material should have been repaired and used, return old material for new and have old material repaired locally where it pays to do so, and where it does not, send it to the reclamation plant.

Educate the users as to the value in dollars and cents of the material they are using. One of the principal causes of misuse and waste of material is ignorance of its value in dollars and cents. While there are many people in large corporations who do not care for the waste they cause, the larger percentage by far of the employees cause waste through habit and ignorance of values. Object lessons well presented are one of the best ways to educate the users of material. A good method to prevent its being necessary to reclaim material is to make it hard occasionally to obtain, thus forcing the user to help himself.

The change in patterns and designs on account of increases in size and other causes is a big factor in the waste of material, and great care should be exercised before any change.

It is necessary to reclaim a large amount of material and work it over into something else on account of not having had proper care to preserve it. A little paint on steel and finished surfaces is often the cheapest reclamation work that can be done. Material in store stock, as well as charged out material of this kind, should be given the necessary attention to preserve it. It is not good practice to store cut nuts or material with finished surfaces in exposed places.

It does not pay to reclaim material at the point of origin where it involves extra handling or expense. However, where material can be reclaimed at the point of origin at less cost than at a reclamation plant, and where it can be repaired and distributed at the same cost as at a reclamation plant, it should be done. But there is danger of duplicating work and hidden expense in reclaiming at the point of origin.

As a rule scrap wharf facilities, as the term suggests, fall heir to what is left in the shop yard in the way of facilities. Wharves, buildings and storage bins for such purposes are usually the result of improvised and temporary structures. Many times the facilities are not only inadequate, but expensive to operate; still their general revision is delayed or prevented by the large outlay to change the plant as a whole, and for the reason that the very first preparations, which perhaps were necessary to meet an emergency, grew piecemeal until they precluded the re-arrangement for greater economy except at considerable cost. Oftentimes unsuitable buildings have been gradually built up with which inadequate facilities the local foremen are badly hampered in their work of handling, inspecting and assorting materials for re-use, repairs or sale.

The scrap dock should be organized so it will have adequate supervision for reclaiming material, and the men sorting scrap thoroughly instructed as to what material should be saved for the reclamation plant. The supervision should constantly inspect the sorting to see that no material is being sold for scrap that can be reclaimed. The profit or loss in reclaiming material is often determined by the handling. One good way to educate is to have a sample or exhibition place where samples or the material to be reclaimed can be seen by the men doing the work, and when mistakes are made, their attention should be called to them and the exhibit also. It has also been found economical to have a schedule so arranged that shop foremen and heads of various departments are permitted to take their turn at the wharf in the supervision of the work generally.

The physical handling will depend on local conditions. This, however, is a very important item in the reclamation of material, for, as a rule, excessive handling of reclaimed material will soon eat up the profit of reclamation. It should be an absolute rule that no scrap material of any kind be sold as such until it has been carefully inspected and all reclaimable material removed. Where material reclaimed can be used without any labor, it should be sent to the shipping room or proper storage room and thus eliminate all handling.

Records of car numbers and points from which material comes should be kept so that when material is put in the scrap that should not have been, the matter can be taken up with those at fault. The scrap dock should be so designed that the reclamation plant will be located to reduce the handling of the material to a minimum. Where this is impossible under present conditions, a comprehensive plan should be drawn up, showing the ideal conditions desired, and then work the scrap dock over a little at a time until the desired arrangement is obtained.

All material reclaimed should be inspected by a competent person to see that it is in condition to meet the requirements of its use. The foreman on the scrap dock can pass on this for the material shipped direct from the dock to the work, and the foreman or sub-foreman of the reclamation plant should do so for the material from the reclamation plant. Suitable testing machines should be provided for testing certain materials and gaging them to see that they will meet the requirements. There is much to be said for and against the practice of painting and marking material reclaimed. The committee feels that, generally speaking, material reclaimed should be painted, dipped or rattled.

[Detailed instructions and forms for handling the accounting for scrap and reclaimed material at a reclamation plant were here included in the report.]

The committee finds it impossible to make up a general statement of the saving made by the reclamation of material that would be applicable to all roads, or even to two or more roads, as conditions are so different. The saving will have to be worked up to suit individual needs for each item reclaimed. [Lists were given as a guide and to show what is being done at the present time on some of the roads.]

The committee finds that the moral effect caused by reclaiming material saves many thousands of dollars. The man interested in the welfare of the company, by seeing the vast amount of material reclaimed, exercises much more care in the use of material and finds ways of using it that are cheaper than sending it to the reclamation plant.

The report is signed by D. C. Curtis (chairman), C. B. & Q.; D. D. Cain, S. A. L.; H. S. Burr, Erie; H. Scatchard, N. & W.; R. K. Graham, A. T. & S. F.; C. H. Rost, C. R. I. & P.; J. H. McMillan, N. Y. C., and H. G. Cook, S. P.

In presenting the report, the chairman of the committee regretted that the committee was unable to include details of the Great Northern rolling mill plant, but referred to a description which will be found elsewhere in this issue.

NEW DEVICES

VERTICAL SLABBING MACHINE

The illustration shows a newly designed vertical slabbing machine which is arranged to be driven by a single pulley. It will admit work 34 in. wide, and has a maximum clearance under the spindle of 36 in. The vertical spindle is driven by a bronze worm wheel and hardened steel worm fitted with roller thrust bearings running in oil. Spindle speeds ranging from $16\frac{1}{2}$ to 99 r. p. m. are obtained by means of a gear box giving nine changes; the cross feed on the rail has twelve changes and a reversing fast power traverse. The spindle is $3\frac{3}{8}$ in. in diameter in the driving sleeve and has a No. 6 Morse taper with a broad face key in the end for driving cutters. The spindle sleeve is adjustable by means of a hand controlled rack and pinion.

Auxiliary bushings which rotate with the shaft are carried by the spline shaft bushings to prevent the escape of oil and pre-

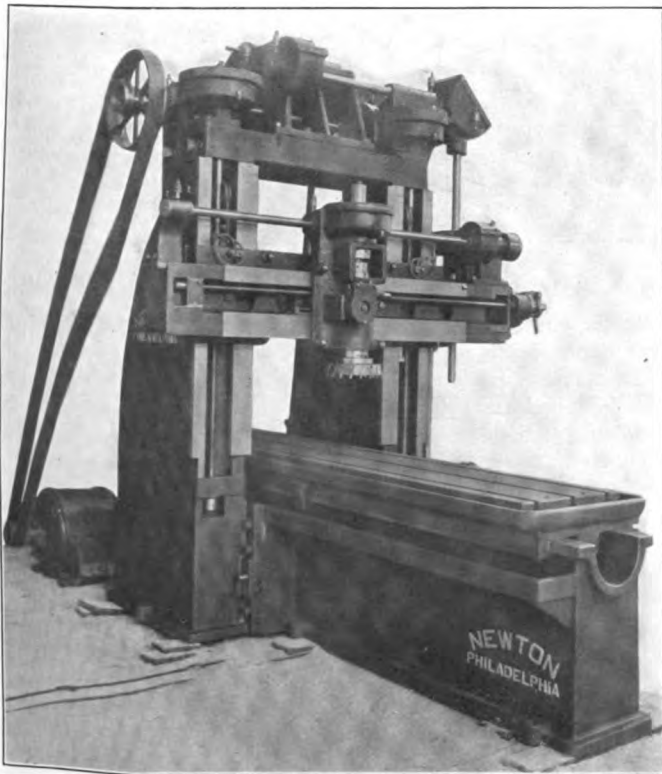

Single Pulley Driven Vertical Slabbing Machine

serve the fixed bushings from undue wear through contact with spline or keyseats.

The table has twelve feeds ranging from 3.55 in. to 13 in. per min., which are independent of the spindle speeds. In addition a rapid traverse of 30 ft. per min. is provided in both directions. All speeds and feeds are obtained through gear boxes, the gears being entirely encased in oil tight boxes. This machine is built by the Newton Machine Tool Works, Inc., Twenty-third and Vine streets, Philadelphia, Pa., and may be had with two, three or four spindles if desired.

WATER POWER IN SWITZERLAND.—In Switzerland water power is conserved and utilized to such an extent that in some towns not an ounce of coal is used. Power, light and heat are furnished by water power.—*Power.*

MOTOR DRIVEN POWER HAMMER

The friction clutch shown in the engraving has been developed by Beaudry & Company, Inc., 141 Milk street, Boston, Mass., in connection with the application of individual motor drive to its

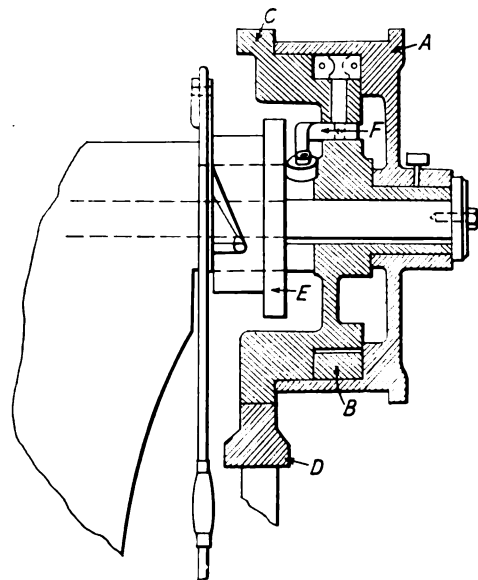

Friction Clutch for Motor Driven Beaudry Hammers

line of power hammers. This clutch makes possible the constant operation of the driving motor attached to the body of the machine without the use of a belt tightening device, while still re-

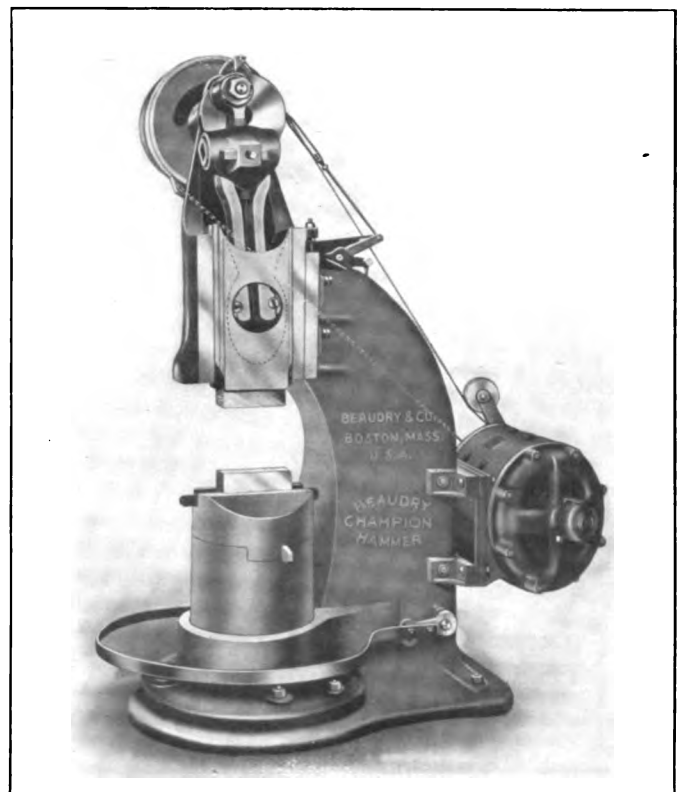

Application of Individual Motor Drive to a Power Hammer

taining the usual foot-pedal method of control of the machine.

The clutch consists of a pulley *A* which runs loose upon the hub of the brake section *C*, the latter being keyed to the shaft. The friction ring *B* is split to fit the head of the expansion pin, which is operated by a lever *F*. This slot in the ring is provided with steel faces to withstand the wear. The cam *D* which operates the clutch is of the spiral type and is controlled by a rod suitably attached to the foot-pedal of the machine.

By varying the pressure of the foot-pedal the operation of the hammer may be perfectly controlled; as the pressure increases the force of the cam against the hardened steel roll in the end of the lever is increased and the expansion pin tightens the friction ring between the pulley and the brake section, the amount of slippage between these two members depending entirely upon the position of the cam. The operation of the brake is automatic, it being released when the hammer is in motion and applied on the release of the clutch.

SAFETY BRAKE SHOE

A recently developed car wheel brake shoe of the insert type which is claimed to have given excellent results both in service and laboratory tests is shown in detail in the engraving. The body of the shoe is a special cast iron mixture poured around three inserts of malleable iron which form an integral part of the back and lug of the shoe. The inserts are rectangular in section and in the center of each is a dust pocket, the opening of which in the face of the shoe is $\frac{3}{4}$ in. wide by $2\frac{1}{4}$ in. long. The back of the shoe is so formed that it is well secured to the cast iron body and stiffening ribs are included on the inside.

A test of one of these shoes has recently been made at

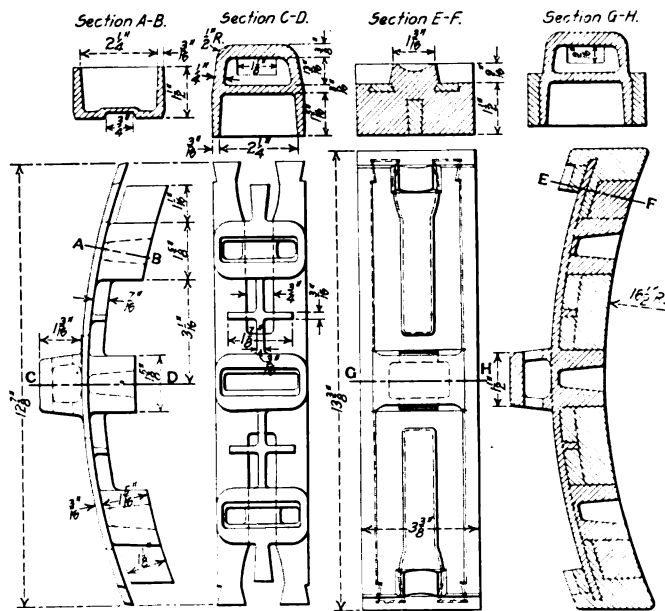

Details of Brake Shoe with Dust Pockets in the Inserts

Purdue University and it is understood that the results were very favorable. When tested on a cast iron wheel at a pressure of 2,808 lb. it developed a coefficient of friction of 28.01 per cent; when the pressure was increased to 6,840 lb. the coefficient was 20.37 per cent. The coefficients required by the Master Car Builders' specifications are 22 and 16, respectively. A similar test on a steel wheel developed coefficients of 15.92 per cent at a brake shoe pressure of 6,840 lb. and 11.96 per cent at 12,000 lb., as compared with the specification requirements of 12.5 per cent and 11 per cent, respectively. On the steel wheel the loss in weight for each 100,000,000 ft. lb. of work done at an initial speed of 65 miles per hour was 1.04 lb., the specifications permitting a maximum of 4 lb. The average distance of stop on the steel

wheel under 12,000 lb. brake shoe pressure was 890 ft. and under 6,840 lb., was 1,348 ft. On the cast iron wheel the average distance of stop under the low pressure was 881 ft., while under the high pressure it was only 440 ft.

This shoe is known as the Streeter safety brake shoe and the special features of its construction have been patented. Its development is in the hands of A. Mitchell, Bedford building, Chicago, Ill.

A POSITIVE NUT LOCK

The illustration shows a nut locking bolt and nut of a positive locking type which is unlocked by means of a small set screw. This device was developed by Schum Brothers, Metropolitan Tower, New York.

The nut lock consists of three parts: a spring, a movable section and the set screw by which it is unlocked and held in position for the application of the nut. The movable section is applied to a slot through the bolt, in which it has an amount of longitudinal play equal to one-half the pitch of the thread. The spring is placed in a recess on the axis of the bolt toward the head from the movable section and the set screw is threaded

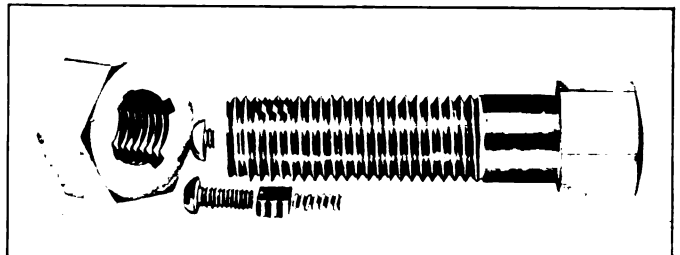

A Positive Nut Locking Device

into the end of the bolt. Four slots are cut in the bore of the nut to the depth of the threads.

In applying the nut the set screw is inserted in the end of the bolt and tightened against the movable section until the threads on both are in alignment. After the nut has been tightened the set screw is removed and when a slight turn of the nut brings one of the slots in line with the movable section the threads on the latter are forced out of alignment with those on the bolt by the action of the coil spring. The nut is thus locked and can only be turned after inserting the set screw in the end of the bolt.

COMBINATION OXY-ACETYLENE WELDING AND CUTTING TORCH

The illustrations show a combination oxy-acetylene torch adapted to both welding and cutting operations which has been brought out by the Imperial Brass Manufacturing Company, Chi-

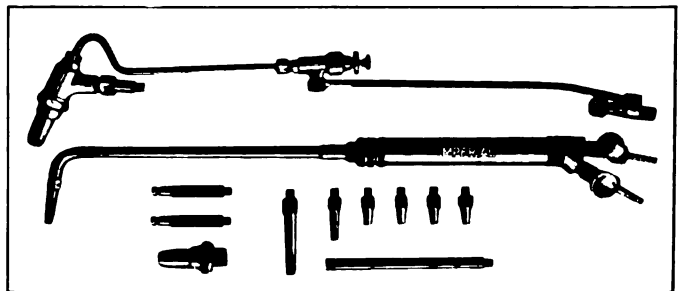

Welding Torch Showing the Cutting Attachment Removed

cago. The welding equipment, as shown in one of the illustrations, is made up of the torch body and a sectional tube having straight

and curved extensions, to which interchangeable tips are applied. By removing the extension from the end of the tube the welding attachment may be applied, the end of auxiliary oxygen tube

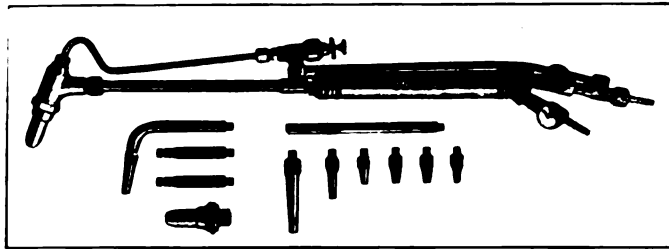

Torch Arranged for Cutting, with Welding Head Removed

being inserted between the control valve on the torch body and the hose connection. A conveniently located valve for controlling the auxiliary oxygen supply forms a part of the cutting attachment.

CENTER DRIVE CAR WHEEL LATHE

A center drive car wheel lathe developed by the Niles-Bement-Pond Company, New York, including several improved features has recently been built at its Niles plant. The improvement of greatest importance in the design of this machine is the use of the herringbone driving gear instead of the usual type of straight toothed gear. The lathe is designed to turn wheels from 28 in. to 42 in. in diameter on the tread and will take outside journals up to 6½ in. in diameter. The opening in the spool is 10 in. wide and accommodates axles up to 9½ in. in diameter; the maximum distance between centers is 94 in.

The herringbone driving gear is mounted on a spool revolving on large bearings in the bed of the machine. The ends of the spool are the face plates which carry the drivers. The driving

the center. The tail stocks, by which the wheels are centered, are moved on the bed and clamped to it by air cylinders, the operating valves of which are within easy reach of the operator.

Each face plate is equipped with three pairs of drivers engaging the inside of the wheel near its circumference. These are tightened by hand and exert a uniform pressure against the

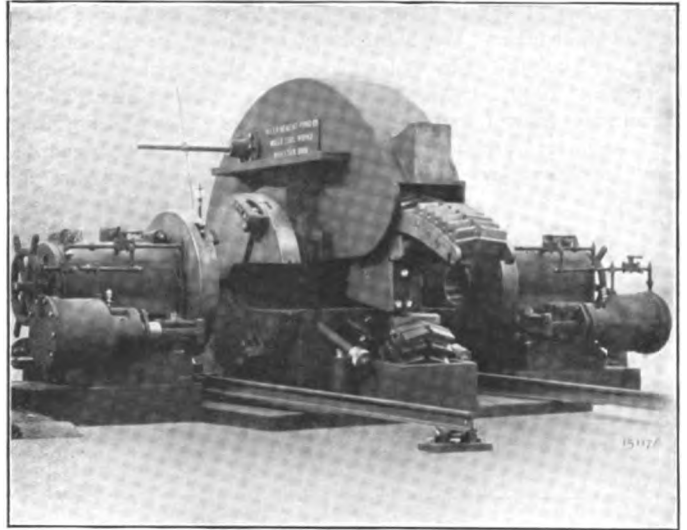

Back of the Car Wheel Lathe Showing Automatically Operated Gap in the Herringbone Gear

wheels. Independent chuck jaws on the tail stock faces engage the outside of the wheels and support them against the thrust of the drivers, relieving the axle of all deflection or torsional strains.

The tool rests are equipped with pneumatic tool clamps which enable the operator to change and clamp tools in a few seconds

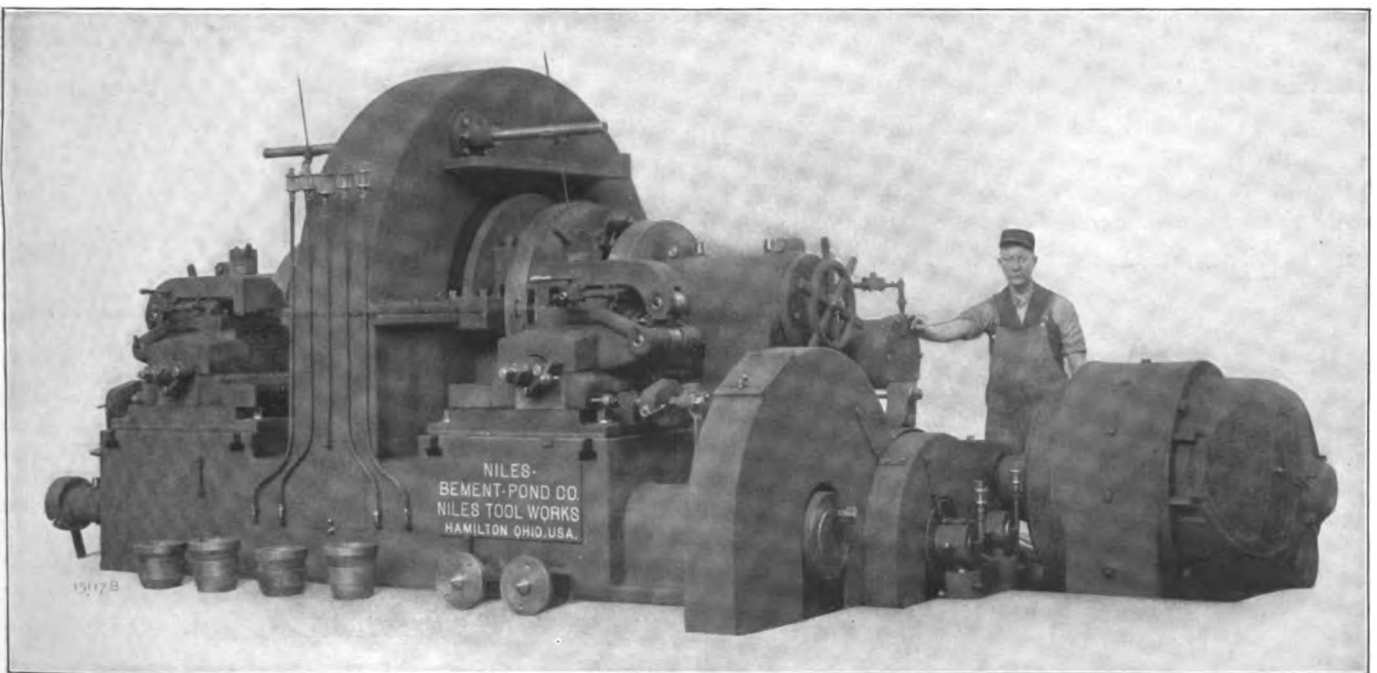

Operating Side of Center Drive Car Wheel Lathe

gear is provided with a patented hinged segment which closes and locks automatically as the wheels are rolled into the machine and unlocks and opens automatically as they are rolled out, no manipulation being required by the operator. A motor driven elevating device operates a hinged track upon which the wheels are rolled into the machine, thus bringing them up into line with

without the use of a wrench. The wedge action of the tool clamp forms a positive lock independent of the air pressure.

The power feed is directly gear driven and is positive in its action. It has a range from 1/8 in. to 5/8 in. per revolution of the face plate sustained by 6.4 feeding strokes per revolution, giving practically a continuous feed. The tool slide has a rapid

in and out adjustment and traverse by hand, the slide screws being fitted with ball thrust bearings to facilitate ease of operation. The tool rest can be swiveled to provide for tapering the wheel treads. A simple calipering device attached to the machine enables the operator to readily size both wheels to the same diameter.

The lathe is driven by a 50-hp. variable speed motor and a 5-hp. constant speed motor is provided to operate the wheel lifting mechanism. When furnished for direct current both motors are equipped with dynamic brakes which enables the operator to stop the driving spool in any desired position and to accurately control the height of the wheels when lifting them to the centers of the tail stock. All gearing is thoroughly guarded and provisions are made to protect all bearings from dirt and chips.

AIR PUMP GLAND NUT LOCK

A device for securely locking air pump gland nuts, which also serves as a protection to the swab against dust, has been developed by N. T. Cline, air brake foreman, Pittsburgh & Lake

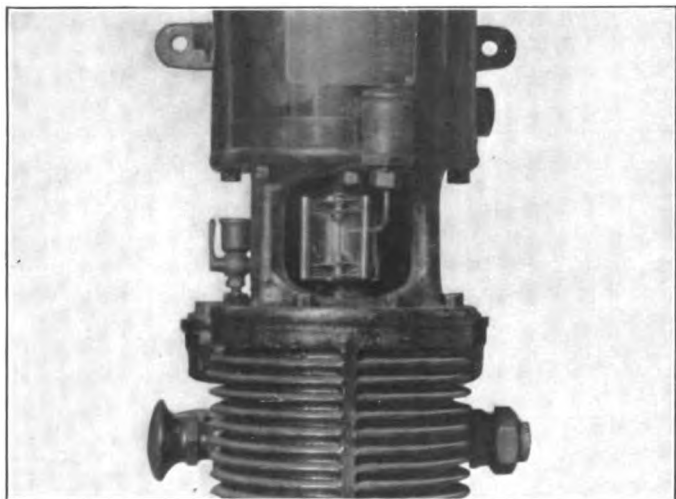

Gland Nut Lock In Place on the Pump

Erie at McKees Rocks, Pa. It consists of a split sleeve, the halves of which are hinged together and held in a closed position by means of springs applied to the hinges. In one of the

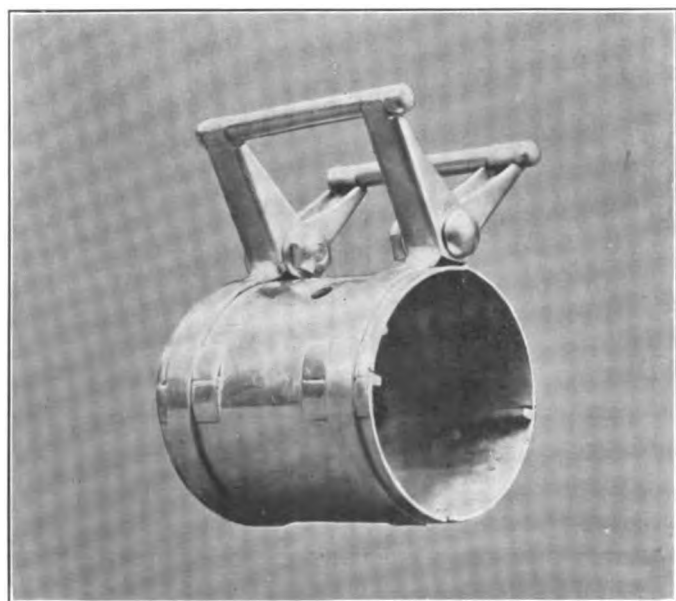

Nut Lock for Air Pump Glands

illustrations the device is shown in place on the pump where it surrounds the two gland nuts and covers the intervening space occupied by the swab. The interior of the sleeve is provided with two internally projecting lugs at each end, which are designed to fit into the spanner grooves of the gland nuts when the latter are properly lined. Since these two nuts are tightened in opposite directions neither can slack off when the nut lock is in position without tightening the other, and both must, therefore, remain tight. The device may be readily removed and to prevent misplacement should be attached to the pump by a short chain. Oil holes are provided through the sleeve for oiling the swab.

HARD GREASE PRESS

A press for forming the grease cakes used in driving box lubricators, as well as candles for rod grease cups has been developed by the Franklin Railway Supply Co., 30 Church street, New York. The device consists of a box for holding the grease which is closed at one end by a plunger operated by a 16 in. by 12 in. air cylinder and at the other by the form through which the grease is pressed. A form cover which may be slipped over the end of the form is provided to facilitate compressing the grease in the box into a compact cake before it is pressed through the form.

When the cover is removed and air admitted to the cylinder, grease is forced out through the form onto a table where it may be cut into suitable lengths by means of the knife held between guides shown in the illustration. It being almost impossible to re-

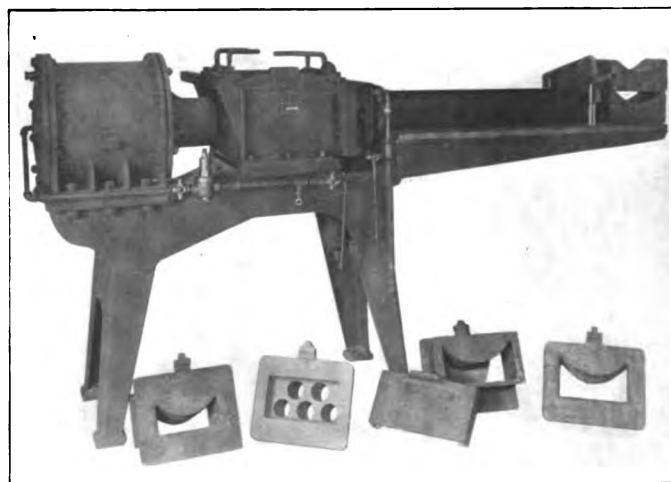

Press for Forming Driving Box Grease Cakes

move the form by hand from the end of the grease box, owing to the body of grease which is partly in the box and partly in the form, a small vertical cylinder has been placed under the form, with its piston acting against the bottom of the form. When air is admitted to the lower end of this cylinder the grease is sheared at the end of the box, and the form raised high enough so that it may be readily removed. A spring above the piston insures its return to the lower end of the cylinder when the pressure is removed.

REPAIRING WAR SHIPS.—As an indication of the complete machine-shop equipment installed on some of the modern battleships and tenders, the following equipment of the U. S. S. Melville—a torpedo-boat destroyer tender—will be of interest: Three 22½-in. geared drills, two 16-in. friction-driven sensitive drills, one 24-in. portable radial drill, two double-emery floor grinders, one double floor buffer, two hacksaws, two center grinders. All these tools are electrically driven.—*American Machinist.*

NEWS DEPARTMENT

The roundhouse, machine shops, car shops and a large part of the rolling stock of the Alaska Northern Railway (the government-owned road) at Seward, Alaska, were destroyed by fire on May 10.

The special committee on the Relations of Railway Operation to Legislation has issued a bulletin showing that on January 1 last there were in service in the United States 12,900 all-steel and 5,700 steel underframe passenger cars, and 43,512 wooden cars. Of the passenger cars acquired by the roads in 1914, 74 per cent were all steel; and of 956 cars under construction January 1, only three were of wood. Seventy-five per cent were all-steel.

SPECIAL TRAIN TO ATLANTIC CITY MECHANICAL CONVENTIONS

The Pennsylvania Lines have announced that for the accommodation of those who will attend the conventions of the Master Mechanics' and Master Car Builders' Associations at Atlantic City next month, a special train will be provided, leaving Chicago at 5:30 p. m. on Monday, June 7, and arriving at Atlantic City about 5 p. m. the following day. The summer tourist fare will be \$31.15 for the round trip, tickets good to return within 30 days, with an extra fare of \$4.

AIR BRAKE LAW MORE RIGID

In the United States Circuit Court of Appeals at Richmond, Va., May 4, the judges affirmed unanimously a decision of the District Court, holding it unlawful for a railroad to require the use of hand brakes to control the speed of trains while on the road; that is to say, presumably, at all places where the law requires the train to be equipped with air brakes in condition for use. The contention of the road was that, with long trains on descending grades, the use of the hand brakes, to supplement the air brakes, was necessary to safety. The court held, in substance, that excepting in extraordinary emergency the use of the hand brakes in such a situation is contrary to the air-brake law.

MEETINGS AND CONVENTIONS

Canadian Railway Club.—At the thirteenth annual meeting of the Canadian Railway Club officers were elected as follows: President, L. C. Ord; first vice-president, R. M. Hannaford; second vice-president, George Smart; secretary, James Powell, and treasurer, W. H. Stewart. T. C. Hudson, E. E. Lloyd, J. Hendry C. Manning, E. B. Tilt and Prof. H. O. Keay were appointed on the executive committee, and W. S. Atwood, W. H. Winterrowd and F. A. Purdy on the audit committee.

American Society of Mechanical Engineers.—The Chicago section of the American Society of Mechanical Engineers held its last 1914-15 seasonal meeting May 14, 1915, at the La Salle Hotel, Chicago. An interesting paper on Electric Locomotives was presented by A. F. Batchelder and A. H. Armstrong, of the General Electric Company, Schenectady, N. Y. The following officers were nominated for the following year: H. M. Montgomery, chairman; Joseph Harrington, vice-chairman; Robert E. Thayer, secretary, and H. T. Bentley and C. E. Wilson as other members of the executive committee.

American Railroad Master Tanners', Coppersmiths' and Pipe-fitters' Association.—At the third annual convention of the American Railroad Master Tanners', Coppersmiths' and Pipe-fitters' Association, to be held at the Sherman House, Chicago, from July 13 to 16, papers will be presented as follows: Auto-

genous Welding, by W. J. Moffett, C. Borchardt and J. P. Hahn; Tinware, by A. Paulis and J. P. Shoemaker; Crude Oil Burners and Forges, by W. J. Hoffett and J. E. Harbough; Locomotive Jackets, by O. E. Schlink, W. W. Nash and T. J. Burke; Lubrication, by C. Borchardt and A. D. Homer; Smoke Prevention, by J. G. Thompson and J. S. Richards; Metals and Their Alloys, by G. B. Hosford; Gaskets and Their Application to Locomotives, by F. Bucholtz; Coach Heating, by G. Schwenk and F. B. Gralike, and Piping, by W. E. Jones.

National Association of Corporation Schools.—The third annual convention of the National Association of Corporation Schools will be held at the Hotel Bancroft, Worcester, Mass., June 7 to 11 inclusive. The convention is held in Worcester this year as the result of an invitation tendered at last year's convention by three of Worcester's leading industrial concerns—the Norton Co., the Norton Grinding Co. and the American Steel & Wire Co.

The National Association of Corporation Schools was founded January 24, 1913, and its first meeting was held in New York University, New York. The functions of the association were designated as follows: to develop the efficiency of the individual employee; to increase efficiency in industry; and to influence courses of established educational institutions more favorably toward industry. The first annual convention of the association was held at Dayton, Ohio, September 16, 1913, and the second annual convention at the home of the Curtis Publishing Company, Philadelphia, Pa.

Western Railway Club.—The Western Railway Club held its annual meeting at the Hotel LaSalle, Chicago, on May 18. Dr. W. F. M. Goss presented a very interesting address on his experience in Germany at the time he visited that country for the purpose of studying locomotive superheater practice. He paid special tribute to Robert Garbe and Wilhelm Schmidt. Wilhelm Schmidt perfected the superheater and, which was by far the most arduous task, interested the imperial government in its adoption. Robert Garbe was the chief mechanical officer in charge of the superheater locomotives of the government lines and to him is due the success of the superheater in actual practice.

A unique form of entertainment was presented with W. E. Symons and the Boosters' Committee of the club as the leading actors. Mr. Symons attacked the Boosters' Committee in a most emphatic manner and had the entire assemblage thoroughly wrought up with his insinuations and accusations. This was carried to such a point that finally the president had to call on the Boosters' Committee to escort Mr. Symons to the refreshment room, and not until then was it apparent that his tirade was a part of the entertainment program. The following officers were elected for the ensuing year: President, H. H. Harvey, general car foreman, Chicago, Burlington & Quincy; first vice-president, W. E. Dunham, supervisor of motive power and machinery, Chicago & North Western; second vice-president, A. R. Kipp, mechanical superintendent, Minneapolis, St. Paul & Sault Ste. Marie; secretary and treasurer, Joseph W. Taylor; executive committee, A. LaMar, master mechanic, Pennsylvania Railroad; George S. Goodwin, mechanical engineer, motive power department, Rock Island Lines, and Edwin G. Chenoweth, mechanical engineer car department, Rock Island Lines. The secretary reported a total membership of 1,395 members and a cash balance of \$132.54.

American Society for Testing Materials.—The eighteenth annual meeting of the American Society for Testing Materials

will be held at the Hotel Traymore, Atlantic City, N. J., June 22 to 26.

At the first session meeting, on Tuesday, June 22, at 11 a. m., opening business will be conducted and reports will be received from the committees on Standard Specifications for Coal, and on Standard Specifications for Coke.

At the second session, on Tuesday, at 3 p. m., reports will be received from the committees on Standard Specifications for Wrought Iron; Standard Specifications for Cast Iron and Finished Castings; Corrosion of Iron and Steel, and Standard Tests of Insulating Materials.

The subjects assigned for the remaining sessions are as follows:

Third, Tuesday, June 22, 8 p. m., Non-Ferrous Metals.

Fourth, Wednesday, June 23, 10 a. m., Steel.

Fifth, Wednesday, June 23, 8 p. m., Heat Treatment of Steel.

Sixth, Thursday, June 24, 10 a. m., Testing Apparatus. Among the four papers to be presented at this session will be one by C. D. Young, engineer of tests, of the Pennsylvania Railroad, entitled: The New Physical and Chemical Laboratory of the Pennsylvania Railroad at Altoona.

Seventh, Thursday, June 24, 3 p. m., Cement and Concrete.

Eighth, Friday, June 25, 10 a. m., Ceramics, Gypsum and Lime.

Ninth, Friday, June 25, 3 p. m., Preservative Coatings and Lubricants.

Tenth, Saturday, June 26, 10 a. m., Road Materials, Timber and Rubber.

Recreation periods are provided for Wednesday afternoon and Friday evening, and a smoker is announced for Thursday evening. Special rates have been secured in the hotel for the members of the society and their guests. In addition to the reports of the standing committees and the presentation of monographs on the special subjects, the convention will consider four proposed amendments to the by-laws affecting membership and the adoption of standards.

The following list gives names of secretaries, dates of next or regular meetings, and places of meeting of mechanical associations.

AIR BRAKE ASSOCIATION.—F. M. Nellis, 53 State St., Boston, Mass.

AMERICAN RAILROAD MASTER TINNERS, COPPERSMITHS AND PIPEFITTERS' ASSOCIATION.—W. E. Jones, C. & N. W., 3814 Fulton street, Chicago. Annual meeting, July 13-16, 1915, Hotel Sherman, Chicago.

AMERICAN RAILWAY MASTER MECHANICS' ASSOCIATION.—J. W. Taylor, Karpen building, Chicago. Convention, June 9-11, 1915, Atlantic City, N. J.

AMERICAN RAILWAY TOOL FOREMEN'S ASSOCIATION.—Owen D. Kinsey, Illinois Central, Chicago. Convention, July 19-21, 1915, Hotel Sherman, Chicago.

AMERICAN SOCIETY FOR TESTING MATERIALS.—Prof. E. Marburg, University of Pennsylvania, Philadelphia, Pa. Convention, June 22-26, 1915, Hotel Traymore, Atlantic City, N. J.

AMERICAN SOCIETY OF MECHANICAL ENGINEERS.—Calvin W. Rice, 29 W. Thirty-ninth street, New York. Annual meeting, December 7-10, 1915, New York.

ASSOCIATION OF RAILWAY ELECTRICAL ENGINEERS.—Joseph A. Andreucetti, C. & N. W., Room 411, C. & N. W. Sta., Chicago. Annual meeting, October, 1915.

CAR FOREMEN'S ASSOCIATION OF CHICAGO.—Aaron Kline, 841 North Fifthth Court, Chicago; 2d Monday in month, except July and August, Lytton building, Chicago.

CHIEF INTERCHANGE CAR INSPECTORS' AND CAR FOREMEN'S ASSOCIATION.—S. Skidmore, 946 Richmond street, Cincinnati, Ohio. Annual meeting, September 14-16, 1915, Richmond, Va.

INTERNATIONAL RAILWAY FUEL ASSOCIATION.—C. G. Hall, 922 McCormick building, Chicago.

INTERNATIONAL RAILWAY GENERAL FOREMEN'S ASSOCIATION.—William Hall, 1126 W. Broadway, Winona, Minn. Convention, July 13-16, 1915, Hotel Sherman, Chicago.

INTERNATIONAL RAILROAD MASTER BLACKSMITHS' ASSOCIATION.—A. L. Woodworth, Lima, Ohio. Convention, August 17, 1915, Philadelphia, Pa.

MASTER BOILER MAKERS' ASSOCIATION.—Harry D. Vought, 95 Liberty street, New York.

MASTER CAR BUILDERS' ASSOCIATION.—J. W. Taylor, Karpen building, Chicago. Convention, June 14-16, 1915, Atlantic City, N. J.

MASTER CAR AND LOCOMOTIVE PAINTERS' ASSOC. OF U. S. AND CANADA.—A. P. Dane, B. & M., Reading, Mass. Convention, September 14-17, 1915, Detroit, Mich.

NIAGARA FRONTIER CAR MEN'S ASSOCIATION.—E. Frankenberger, 623 Brisbane building, Buffalo, N. Y. Meetings monthly.

RAILWAY STOREKEEPERS' ASSOCIATION.—J. P. Murphy, Box C, Collinwood, Ohio.

TRAVELING ENGINEERS' ASSOCIATION.—W. O. Thompson, N. Y. C. & H. R., East Buffalo, N. Y. Convention, September 7-10, 1915, Hotel Sherman, Chicago, Ill.

PERSONALS

It is our desire to make these columns cover as completely as possible all the changes that take place in the mechanical departments of the railways of this country, and we shall greatly appreciate any assistance that our readers may give us in helping to bring this about.

GENERAL

HENRY BARTLETT, mechanical superintendent of the Boston & Maine at Boston, Mass., has been appointed chief mechanical engineer, reporting to the president. He will have general supervision over matters connected with motive power and other equipment in so far as may be necessary to preserve the standards and systems of the railroad and to secure adherence thereto. All plans and specifications for locomotives and other equipment will be prepared by him and approved by the general manager. The construction of new equipment will be supervised by him and he will perform such other duties in connection with motive power and equipment as may be assigned to him by the president. Charles H. Wiggin, superintendent of motive power at Boston, will report to the general manager. He will have charge of all locomotives and car shops, engine houses and appurtenances, and of the maintenance, repair and inspection of locomotives and other equipment. The master mechanics, superintendents of shops, electrical superintendent, general car inspector, general air brake inspector and the general piece work inspector will report to him.

C. E. BROOKS, general foreman at the Transcona, Man., shops of the Grand Trunk Pacific, has been appointed acting superintendent of motive power, with headquarters at Transcona, succeeding Joseph Billingham, resigned.

S. J. HUNGERFORD, superintendent of rolling stock, western lines of the Canadian Northern, at Winnipeg, Man., has had his jurisdiction extended over the eastern lines.

HARRY A. MACBETH, whose appointment as superintendent of motive power of the New York, Chicago & St. Louis, with headquarters at Cleveland, Ohio, was announced in the May number, was born on September 23, 1867, at Wellsville, Ohio. He was educated in the common and high schools and entered railway service in October, 1883, with the New York, Chicago & St. Louis. He was machinist apprentice from 1884 until 1887, machinist from 1887 to 1891, gang foreman from 1891 to 1898, when he was appointed general foreman. This position he held until 1905, when he was appointed master mechanic, and he has served in that capacity for the last 10 years, recently with headquarters at Conneaut, Ohio, from which position he is now promoted to superintendent of motive power.

W. H. WINTERROWD, mechanical engineer of the Canadian Pacific at Montreal, Que., has been appointed assistant to the chief mechanical engineer, with headquarters at Montreal.

MASTER MECHANICS AND ROAD FOREMEN OF ENGINES

T. C. BALDWIN, whose appointment as master mechanic of the New York, Chicago & St. Louis at Conneaut, Ohio, was announced in the May number, was born in East Springfield, Pa., June 25, 1875. On finishing the grammar school he entered the office of the master mechanic of the Nickel Plate as a messenger boy, serving three years until November, 1892, as messenger and tool room boy. He then became a machinist's apprentice and after learning the trade served as a machinist and tool maker until January, 1904, when he was appointed machine shop foreman. In May, 1905, Mr. Baldwin was transferred to Buffalo, N. Y., as roundhouse foreman at that point where he served until May, 1910, again becoming machine shop foreman at that time and serving in that capacity until his recent appointment to the position of master mechanic.

J. H. MILLS, formerly master mechanic of the Ontario division of the Canadian Pacific at West Toronto, Ont., has been appointed master mechanic of the Lake Superior division at North Bay, Ont., succeeding H. G. Reid.

W. J. PICKRELL has been appointed master mechanic of the Ontario division of the Canadian Pacific at Toronto, Ont., succeeding D. T. Main, promoted.

W. C. SEALY has been appointed master mechanic of the Ontario lines of the Grand Trunk at Toronto, Ont., succeeding J. Markey, deceased. Mr. Sealy entered the service of the Grand Trunk in the erecting shop at Stratford, Ont., as an apprentice in 1901, having previously attended the high school at that point. The apprenticeship educational system had at that time just been inaugurated. He continued to serve at Stratford for about eight years as an apprentice, charge hand and finally as general foreman of the shop at that point. He was then transferred to Chicago as general foreman, in which capacity he was employed until 1913 when he was promoted to the position of assistant master mechanic of the Ontario lines. He occupied this position until May 1 of this year when he became master mechanic.

T. WINDLE, formerly master mechanic of the International & Great Northern at Palestine, Tex., has been appointed master mechanic of the Denver & Salt Lake, with headquarters at Tabernash, Colo.

CAR DEPARTMENT

R. S. MOUNCE has been appointed general foreman of car repairs of the Erie Railroad at Jersey City, N. J., succeeding P. Fox, deceased.

L. C. WHITE has been appointed general car foreman of the Pere Marquette at St. Thomas, Ont., succeeding A. White.

F. B. ZERCHER, formerly superintendent of car shops of the Canadian Pacific at Montreal, Que., has been appointed master car builder, Eastern lines, with headquarters at Montreal.

SHOP AND ENGINE HOUSE

H. G. BECKER, formerly general erecting shop foreman of the Lehigh Valley shops at Sayre, Pa., has been appointed general foreman of the Delaware & Hudson shops at Watervliet, N. Y., succeeding A. A. Masters, resigned.

WILLIAM BRANDT has been appointed general foreman of the shops of the New York, Chicago & St. Louis, at Conneaut, Ohio, succeeding T. C. Baldwin, promoted.

W. HOPE, formerly erecting shop foreman of the Canadian Northern at Joliette, Que., has been appointed foreman at Limoilou, Que.

F. P. HOWELL, formerly general foreman of the erecting shop of the Atlanta Coast Line at Waycross, Ga., has been appointed general foreman at Savannah, Ga.

T. S. LOWE, formerly master mechanic of the Canadian Northern at Limoilou, Que., has been appointed general foreman at that point.

J. A. MITCHELL, locomotive foreman of the Grand Trunk Pacific at Biggar, Sask., has been appointed general foreman at Transcona, Man.

A. McTAVISH, formerly locomotive inspector of the Grand Trunk Pacific at Transcona, has been appointed locomotive foreman at Biggar, Sask.

WILLIAM H. NOLAN, general foreman of engine houses and shops of the Boston & Maine, at East Deerfield, Mass., has been given jurisdiction over the inspection and repair of rolling stock at that point and Greenfield, Mass.

T. W. PALOS has been appointed locomotive foreman of the Grand Trunk Pacific at Graham, Ont., succeeding R. G. Gilbride, resigned.

H. C. SPICER has been appointed general foreman of the erecting shop of the Atlantic Coast Line at Waycross, Ga.

J. A. WALTON has been appointed locomotive foreman of the Grand Trunk at London, Ont., succeeding J. R. Leckie, promoted.

PURCHASING AND STOREKEEPING

WALTER R. OWEN, assistant purchasing agent of the Chicago, Rock Island & Pacific at Chicago, has been appointed assistant general purchasing agent, with headquarters at Chicago.

COMMISSION APPOINTMENTS

A. L. MOLER has been appointed senior inspector of motive power for the eastern district, in the division of valuation, Interstate Commerce Commission, with headquarters at Washington.

OBITUARY

PATRICK FOX, general foreman car repairs of the Erie Railroad at Jersey City, N. J., died on May 10 at the age of 56 years. Mr. Fox had been in the service of the Erie Railroad for nearly 40 years. He was employed in the Buffalo car shops from 1876 until March, 1886, where he served as car builder, gang foreman and shop inspector, until transferred to Jamestown, N. Y., as foreman at that point. In October, 1887, he was made foreman of car repairs at Galion, Ohio, in which capacity he served until the spring of 1892. He was then made general foreman of car repairs at Galion, Ohio, in which capacity he served until the spring of 1892. He was then made general foreman of car repairs at Huntington, Ind., and in April, 1902, was transferred to Buffalo, N. Y., as general foreman of car repairs at that point, where he remained until July, 1905. He then became general foreman of car repairs at Jersey City, N. J., which position he occupied at the time of his death.

JAMES MARKEY, master mechanic of the Ontario lines of the Grand Trunk at Toronto, Ont., died at his home there, April 22, at the age of 54 years.

P. P. MIRTZ, assistant engineer, mechanical department, of the New York Central, died suddenly on May 11, in New York.

NEW SHOPS

CHICAGO, ROCK ISLAND & PACIFIC.—This company will build a small repair shop for light repairing at Biddle, Ark.

SOUTHERN RAILWAY.—In connection with new terminal facilities for this company at South Richmond, a contract has been awarded to Alsop & Pierce, Newport News, Va., for the construction of a new oil house to cost \$6,975.

MORGAN'S LOUISIANA & TEXAS RAILROAD & STEAMSHIP COMPANY.—This company will construct new shop buildings and probably install some new tools and equipment at Algiers, La. The tools and equipment have not yet been definitely determined.

THE SEABOARD AIR LINE.—This company has let contracts to build a temporary shop building at Portsmouth, Va., as a temporary cover on a portion of the burnt shop area, but no decision has been reached for the construction of a permanent building.

NORFOLK SOUTHERN.—This company is putting up a small shed at the Raleigh, N. C., yards for the protection of workmen in placing steel underframes on cars. The building will be 40 ft. by 60 ft. The company has also provided additional tracks for handling about 75 cars at one time. The cost of the work will be about \$5,000.

OREGON-WASHINGTON RAILROAD & NAVIGATION COMPANY.—This company will build a one-story, 10-stall roundhouse at Walla Walla, Wash. It will have brick walls, mill interior and concrete pits. The approximate cost will be \$25,000. Moore Brothers, Portland, Ore., have been awarded the contract.

SUPPLY TRADE NOTES

D. J. Normoyle has been appointed manager of the Philadelphia office of the Niles-Bement-Pond Company, Inc.

The Taylor Wharton Iron & Steel Company, Philadelphia, Pa., is working on an order for shrapnel shells at its Tioga plant.

Joseph F. Dixon, Jr., foreign sales manager of the Allis-Chalmers Company, died at his home in Brooklyn, N. Y., on April 30.

The Pyrene Manufacturing Company has moved its head offices in New York to the Vanderbilt Concourse building, 52 Vanderbilt avenue.

Charles Spalding, representative of the Gisholt Machine Company, Madison, Wis., in Chicago territory, has transferred his headquarters from the Chicago office to Detroit.

A. W. De Revere has been appointed district sales manager of the Terry Steam Turbine Company, Hartford, Conn., in charge of offices at 524 Monadnock block, Chicago.

The Pittsburgh plant of the American Locomotive Company, which has been virtually idle for two years, is being overhauled and plans are being made for a complete resumption of work.

H. S. Collette, secretary of J. G. White & Co., Inc., and the J. G. White Engineering Corporation, New York, has resigned from these companies and expects to reside permanently in California.

The Edgar Allen American Manganese Steel Company, Chicago, has changed its name to the American Manganese Steel Company. This company has foundries at Chicago Heights, Ill., and New Castle, Del.

The U. S. Metal & Manufacturing Company, New York, has been appointed eastern sales agent for the Union Fibre Company, Winona, Minn., makers of Linofelt for refrigerator and Feltlino for steel cars.

F. K. Irwin, formerly with the New York, New Haven & Hartford, has become connected with the Chicago office of the Niles-Bement-Pond Company. He will look after the railroad machine tool business in that territory.

The Standard Brake Shoe & Foundry Company, Pine Bluff, Ark., a new firm, has taken over the Dilley Foundry Company, and will start work at once on the construction of a new \$40,000 plant, including an open-hearth steel foundry.

The Ballman-Witten Manufacturing Company, 5407 Easton avenue, St. Louis, Mo., has been incorporated with \$100,000 capital stock to manufacture piston rings. Lathes and boring machines will be installed. E. C. Ballman is president.

The Pittsburgh Steel Car Company, Pittsburgh, Pa., has been incorporated at Dover, Del., with a capital of \$100,000, and will manufacture and deal in steel railroad cars. The incorporators are Norman P. Coffin, Herbert E. Latter, Wilmington, Del., and Clement M. Enger, Elkton, Md.

H. E. Preston, formerly with the American Can Company, and prior to that with the Felt & Tarrant Manufacturing Company, Chicago, has joined the periodograph sales force of the Gisholt Machine Company, Madison, Wis., and will have headquarters at the company's Chicago office.

The item appearing in the May number, page 265, announcing the appointment of a new manager of the Boston branch of Manning, Maxwell & Moore, Inc., incorrectly gave the name of the new branch manager as J. S. Wright. The name given should have been Jos. Wainwright.

Fred A. Geier, president of the Cincinnati Milling Machine Company, Cincinnati, has purchased the interest of Larz An-

derson in the Cincinnati Shaper Company and the Cincinnati Gear Cutting Machine Company, Cincinnati. P. G. March will continue as president, and the business will be extended.

E. E. Winship, formerly manager of the Cincinnati branch of Manning, Maxwell & Moore, Inc., has been appointed manager of the Cleveland branch, effective May 1. C. H. Overkamp, formerly of the Conover-Overkamp Machine Tool Company, Dayton, Ohio, has been made manager of the Cincinnati office.

The operation of the plant of the Continental Car & Equipment Company at Highland Park, Louisville, Ky., which was shut down when the company went into bankruptcy, will be resumed by the Continental Car Company, which has been incorporated with \$40,000 capital stock by A. H. McKinley and others.

The Davis Manufacturing Company, Milwaukee, Wis., manufacturer of gasolene motors, has closed a contract with the Railway Engineering & Equipment Company, Indianapolis, Ind., for the construction of motors, trucks and underframes for the entire output of railway coaches of the latter company for a period of five years.

P. H. Biggs, sales manager of the Cleveland territory of Manning, Maxwell & Moore, has resigned from that position and has taken an office in the Schofield building, Cleveland, Ohio, under the name of the P. H. Biggs Machinery Company. He will handle machine tools and hydraulic machinery, and represent a limited number of manufacturers in the northern Ohio territory.

The Whiting Foundry Equipment Company, Harvey, Ill., has taken over the foundry equipment business of the Central Iron Works, Quincy, Ill., thereby adding to its line the dust arresters and water cinder mills formerly manufactured by that company. The Whiting Company has retained one of the engineers of the Central Iron Works. It will also be prepared to furnish repairs for Central Iron Works equipment.

The Pittsburgh Steel Car Company, recently organized by Pittsburgh capital, is planning to erect a plant at Greenville, Pa., which will provide for a capacity of 7,500 steel cars a year. The officers of the company are W. A. Scott, Jr., president; H. B. Scott and L. A. Meyran, vice-presidents; H. W. Best, treasurer; George W. Ramby, secretary, and E. B. Caughey, office manager. The offices are at 512 Ferguson building, Pittsburgh.

Laurence Hamill, for some time district agent for the Buda Company, Chicago, and W. B. Hickox, formerly in charge of sales of the Adams Bagnall Electric Company, Cleveland, Ohio, have formed the Hamill-Hickox Company, with offices in the Hickox building, Cleveland. The new company will act as direct representatives in Ohio and surrounding territory for railway supplies, and will continue to handle the Buda Company account and several others.

The Pacific Great Eastern Equipment Company has been incorporated with a capital of \$3,000,000 and office in Vancouver, B. C., to purchase, hire or manufacture railway cars, locomotives or other rolling stock, deal in rails, contractors' equipment, appliances and tools, and to sell or hire the same to railway companies and contractors. The provisional directors are: P. Welch, E. F. White, E. W. Kaufmann, A. H. Sperry and D. C. Pennington, Vancouver, B. C., all of whom are associated with the Pacific Great Eastern Railway.

The Reading-Bayonne Steel Casting Company has recently sold its Bayonne, N. J., plant to the Bayonne Steel Casting Company, and its Reading, Pa., plant to the Reading Steel Casting Company. The Bayonne Steel Casting Company has elected officers as follows: William D. Sargent, president and treasurer, and A. J. Passino, secretary. H. K. Pollard has been appointed sales manager, and Charles Lidstone, superintendent. The officers of the Reading Steel Casting Company are: J.

Turner Moore, president; M. G. Moore, vice-president; H. M. Doty, secretary and treasurer; M. G. Moore is also sales manager, and J. Douglas Genger, superintendent. The Reading-Bayonne Steel Casting Company was a combination of these two companies organized about December, 1911.

Charles William Sherburne, who died in Boston, Mass., on May 6, after an illness of three years, was the founder of the railway supply firm of Sherburne & Co., Boston, Mass., and had been at its head for about 50 years.



C. W. Sherburne

Mr. Sherburne was born in Boston on October 13, 1839. He was for a time employed on the Vermont & Canada, now a part of the Central Vermont, but soon returned to Boston to engage in the railway supply business, under the name of Sherburne & Co. Mr. Sherburne was a very active man, and until within a few years he was president of the Armstrong Transfer Express Company, president of the Star Brass Manufacturing Company, a director of the Armstrong Dining & News Company, and treasurer

of the company, will be in executive charge of the work, and Walter L. Clark, recently vice-president of the Niles-Bement-Pond Company, will be manager of the combined plants in charge of operations. The corporate and commercial identity of the J. Stevens Arms & Tool Company will be retained, and its usual line of rifles will be manufactured. When the war order rush is over the other plants will probably be devoted to the manufacture of the usual line of Westinghouse products.

George T. Reiss, vice-president of the Niles Tool Works Company, and a director of the Niles-Bement-Pond Company, died at his home in Hamilton, Ohio, on May 5. Mr. Reiss had



G. T. Reiss

been in the employ of the Niles Tool Works Company continuously since 1878. He was born in Cincinnati, December 6, 1849. In 1877 he went to Hamilton. He was first employed there as a draftsman, but in 1878 he was given the position of master machinist with the Niles Tool Works Company, and placed in charge of the company's engineering department. He was subsequently chief mechanical engineer and later superintendent of the drafting department. Eventually, he became vice-president of the company and a director of the Niles-

Bement-Pond Company. He was an inventor of considerable importance and held a position of prominence in the affairs of the city in which he made his home.

William Sterling Hodges, of the Baldwin Locomotive Works, with his wife and two sons, was lost in the sinking of the Lusitania. Mr. Hodges was born in Philadelphia on March 1, 1882,



W. S. Hodges

and was a graduate of the Central Manual Training School. He entered the drafting department of the Baldwin Locomotive Works on December 18, 1899. In July, 1912, he went to China as technical representative. He remained there about two years, returning in the summer of 1914. In September, 1914, he went to Russia and remained there until the middle of December. Early in January, 1915, he was assigned to duty as technical representative or agent in Paris. He went there with the intention of returning in April to take his family

back with him to France. He returned to this country on the Lusitania when that vessel made her last trip westbound, and a week later, with his family, sailed on the same ship. Mr. Hodges showed great capability as a designer in locomotive construction. He patented a number of devices, the best known of which is the trailing truck bearing his name.

C. B. Yardley, Jr., at present eastern railroad representative of the William C. Robinson & Son Company, Baltimore, Md., with office at New York, will on June 1 become manager of the railway department of the



C. B. Yardley, Jr.

Lubricating Metal Company, 2 Rector street, New York. Mr. Yardley was for a time manager of the railway department of the United States Metal Products Company, and previous to that was for several years railroad representative of Jenkins Brothers, New York. He is a prominent member of the Railway Supply Manufacturers' Association. In 1912-1913 he served as chairman of the enrollment committee of that organization, and at present is chairman of its badge committee. He has also served as secretary

and treasurer of the Railway Materials Association, which is associated with the Railway Storekeepers' Association, and in May, 1914, was elected president of that organization.

The Westinghouse Electric & Manufacturing Company, which has received a large order for rifles from the British government, has practically completed negotiations for the purchase of the plant and business of the J. Stevens Arms & Tool Company, of Chicopee Falls, Mass., and the plants of the Stevens-Duryea Company in Chicopee Falls and East Springfield. The company plans to fill the order at these plants. L. A. Osborne, vice-

CATALOGS

AIR METERS.—A four-page folder has been issued by the New Jersey Meter Company, Plainfield, N. J. This folder is devoted to the Tool-ometer, a recently developed form of air flow meter. This device is adapted to checking the amount of compressed air used by the various types of portable pneumatic tools.

WIRING.—The Fargo Manufacturing Company, Inc., Poughkeepsie, N. Y., has recently issued catalog No. 800, which deals with its types "A" and "B" connecting devices for electric wiring. The catalog is well illustrated with sectional drawings and engravings showing the construction of the various types of connectors.

RIVETERS.—Catalog No. 3 of the Vulcan Engineering Sales Company, Chicago, deals with a line of pneumatic riveters manufactured by the Hanna Engineering Works, Chicago. These machines are of a variety of types and sizes, the special feature of the line being the toggle motion by which the power is transmitted to the ram.

ARCH TUBE CLEANERS.—Catalog W-1 of the Lagonda Manufacturing Company, Springfield, Ohio, is devoted to its line of arch tube cleaners. Several types of cutting heads are shown and a number of accessories are listed, including repair parts. In addition to the pneumatic cleaners, water and steam driven cleaners are shown.

EXPANDED METAL LATH.—Kno-Burn expanded metal lath is the subject of a 52-page booklet issued by the North Western Expanded Metal Co., Old Colony Building, Chicago. The advantages claimed for this type of lath are outlined in detail, stock sizes and weights are given and a large number of illustrations are included giving details of application.

WAGON AND TRUCK LOADERS.—This is the title of book No. 210 of the Link-Belt Company, Chicago, which is devoted to a line of portable loaders for use in handling coal, sand, stone, gravel and other loose material from storage piles into wagons, trucks or cars. The book has 47 pages and is profusely illustrated with photographs taken in service.

WATER.—The Kennicott Company, Chicago Heights, Ill., has recently issued a pamphlet entitled *Water, Its Storage Purification and Measurement for Industrial Purposes*, in which are set forth the advantages of soft water as applied to various industries. It contains several illustrations of Kennicott water softener plants and other equipment manufactured by this company.

PORTABLE AIR COMPRESSORS.—Form No. 3,015 issued by the Ingersoll-Rand Co., 11 Broadway, New York, contains 32 pages, 6 in. by 9 in., and is a complete treatise on the subject of portable air compressing outfits. A list of bulletins is given describing in detail each particular line of portable compressors as well as catalogs of the various pneumatic tools and equipment mentioned.

SAFETY RULES.—The Whiting Foundry & Equipment Company has recently issued a poster containing safety rules for cranesmen, crane operators, floor men and repair men. The poster has the words "Safety First" printed in large red letters at the top and the rules are from a safety bulletin issued by the National Founders' Association. The poster is suitable for placing in shops for the guidance of workmen.

AIR COMPRESSORS.—Bulletin No. 34 M, dated March, 1915, and issued by the Chicago Pneumatic Tool Co., describes the class O "Chicago Pneumatic" steam and power driven compressors. The bulletin contains 36 pages, including detailed illustrations of the various parts of these compressors as well as indicator diagrams showing the results obtainable by their use. Tables are included giving the principal data for the various sizes.

VACUUM CAR CLEANERS.—A four-page leaflet entitled bulletin No. 221 A, has been issued by the Thurman Vacuum Cleaner Co., St. Louis, Mo., describing the Thurman No. 2 portable electric car cleaning device. This vacuum cleaner is placed at the side of the coach to be cleaned, and is driven through an electric lamp cord from the lighting circuit in the coach or the terminal yard. The system is now in use on over 25 American railways.

HYDRAULIC FORCING PRESSES.—This is the subject of catalog No. 92, issued by the Watson-Stillman Company, New York. This book contains 128 pages, thoroughly illustrated and deals with a large number of forcing and miscellaneous presses which this company manufactures. The catalog supersedes catalog No. 70 and part of No. 82. It has been found convenient to divide the various tools into classes, making each class the subject of a catalog. At the back of this book a list is given of these classified catalogs.

WINDOW DEVICES.—The McCord Manufacturing Co., Detroit, Mich., has issued a 56-page catalog dealing with the Universal window devices which this company manufactures. The book is handsomely gotten up and illustrated in color engravings as well as line drawings, the latter giving in detail the arrangement of the different window fixtures. These include weather stripping, locks and racks, sash lifts, anti-rattle bearings, stop casings and parting strips, sash balance brackets, sash balance chain connections, metallic sash, deck sash ratchets, etc.

CRANES.—Book No. 107, issued by the Industrial Works, Bay City, Mich., illustrates and describes the various crane equipment which this company manufactures. This includes wrecking cranes, pile drivers, locomotive cranes, lifting magnets, etc. A section is also devoted to other products such as pillar and transfer cranes, rail saws, transfer tables and wrecking tools. The book contains 88 pages and an insert containing illustrations of a partial set of Industrial wrecking tools. The printing and illustrations are excellent, a high grade of paper being used.

LOCOMOTIVE STOKERS.—The Locomotive Stoker Company, Schenectady, N. Y., in its catalog No. 14-B issued in April, has compiled a list of locomotives to which the Street stoker has been applied. The catalog is a neatly arranged booklet of some 50 pages containing a full-page illustration of each locomotive class to which the stoker has been applied with a table of the principal dimensions and a statement on the facing page of the number of engines equipped. The fact is brought out that at the present time there are in service over 600 locomotives fired by the Street stoker.

SPEED REDUCING GEAR.—Catalog "A" of the Turbo-Gear Company, Industrial building, Baltimore, Md., is devoted to the Turbo reducing gear recently developed by this company for high ratio speed reduction. This device consists of a stationary annular gear, a pinion cut integral with the high speed shaft and intermediate gears, the shafts of which are secured to the cast steel slow speed member. The intermediate gears mesh with the annular gear and the pinion, revolving about the latter. All the gears are of the double helical or herring bone type, and are enclosed in a cast iron housing.

PAINTS.—The St. Louis Surfacer & Paint Company, St. Louis, Mo., has issued a number of circulars and color cards, each one devoted to paints and varnishes for a particular class of work, all of which are neatly bound in a loose-leaf folder. Among the circulars are found the following dealing with paints for railway work: No. 1-A, steel and wood freight car paint; No. 2-A, coach and car surfacer; No. 3-A, locomotive surfacer; No. 5-A, canvas roof paint, floor paint and truck enamel; No. 6-A, hand rail and headlining enamel, rattan seat finish and interior car colors; No. 7-A, coach colors and color varnishes; No. 8-A, station and building paint; No. 9-A, bridge and signal target paint, and No. 14-A, car cleaner and metal polish. A color card is included with each circular.

Railway Age Gazette

MECHANICAL EDITION
INCLUDING THE
AMERICAN ENGINEER

PUBLISHED ON THE FIRST THURSDAY OF EVERY MONTH BY THE
 SIMMONS-BOARDMAN PUBLISHING COMPANY,
 WOOLWORTH BUILDING, NEW YORK, N. Y.

CHICAGO: Transportation Bldg. CLEVELAND: Citizens' Bldg.
 LONDON: Queen Anne's Chambers, Westminster.

EDWARD A. SIMMONS, *President* L. B. SHERMAN, *Vice-President*
 HENRY LEE, *Secretary*

The address of the company is the address of the officers.

ROY V. WRIGHT, *Editor*

R. E. THAYER, *Associate Editor* A. C. LOUDON, *Associate Editor*
 C. B. PECK, *Associate Editor*

Subscriptions, including the eight daily editions of the *Railway Age Gazette* published in June in connection with the annual conventions of the Master Car Builders' and American Railway Master Mechanics' Associations, payable in advance and postage free:

United States, Canada and Mexico.....	\$2.00 a year
Foreign Countries (excepting daily editions)....	3.00 a year
Single Copy	20 cents

Entered at the Post Office at New York, N. Y., as mail matter of the second class.

WE GUARANTEE that of this issue 6,500 copies were printed; that of these 6,500 copies 5,471 were mailed to regular paid subscribers, 155 were provided for counter and news companies' sales, 219 were mailed to advertisers, exchanges and correspondents, and 655 were provided for new subscriptions, samples, copies lost in the mail and office use; that the total copies printed this year to date were 39,000, an average of 5,571 copies a month.

The RAILWAY AGE GAZETTE, MECHANICAL EDITION and all other Simmons-Boardman publications are members of the Audit Bureau of Circulations.

VOLUME 89

JULY, 1915

NUMBER 7

CONTENTS

EDITORIALS:

Welcome the Supply Man.....	329
The Pennsylvania Test Department.....	329
Two July Conventions.....	329
Underframes Should Be Strengthened.....	330
Car Department Officers and Economy	330
Consolidation of Mechanical Associations.....	330
Refinement in Locomotive Design.....	331
New Books	331

GENERAL:

Pennsylvania Railroad Test Department.....	332
Examples of Recent Locomotives.....	338
Characteristics of Plate Springs.....	340
Forged and Rolled Steel Pistons.....	343
Performance of Locomotive Firemen.....	346

CAR DEPARTMENT:

Freight Car Repairs Under a Piece Work System.....	347
Forty-two Years Ago.....	348
Steel Cars of the Arch Roof Type	349
Steel Suburban Cars for the Erie.....	356

SHOP PRACTICE:

Reducing Piston Valve Leakage.....	359
Pillar Crane for Machine Tool Work.....	360
Illinois Central Tool System.....	361
Method of Securing Steam Gages.....	364
Cost of Compressed Air.....	364
A Few Facts About Inspecting Boilers.....	365
Systematic Valve Setting on Locomotives.....	366
Welding Copper and Copper Alloys by Acetylene Methods.....	367
Apprentice School Car.....	369
Cause of High Speed Steel Tool Failures.....	369
Jig for Setting Up Crown Brasses in the Shaper.....	370
Training Official Material and Journeyman Apprentices.....	370

NEW DEVICES:

Driving Wheel Lathe.....	371
Crane Arrangement for Locomotive Shops.....	372
Automatic Drifting Valve	372
Continuous Motion Hammer Bolt Heading Machine.....	373
Instruments for Measuring Hardness and Elasticity of Rubber.....	374
High Speed Blower and Centrifugal Air Compressor.....	374
Sand Blasting Steel Cars.....	376

NEWS DEPARTMENT:

Notes	378
Meetings and Conventions.....	379
Personals	379
Supply Trade Notes.....	381
Catalogs	382

Welcome the Supply Man

A great many mechanical department men receive representatives of railway supply concerns in their offices, largely because they feel that they cannot help themselves. Speaking generally, we believe this to be a wrong attitude to assume. The representatives of a great many of the companies now manufacturing railway supplies are experts in their particular line and regardless of whether or not they make a sale, they are always willing to give a foreman or a master mechanic the benefit of their knowledge and experience. We know of several instances where mechanical department officers have overcome difficulties which were fast growing beyond control, simply by the assistance of a supply manufacturing company's representative who was sufficiently wide-awake to take a general interest in railway matters and was therefore conversant with the methods which had been pursued on another road in overcoming similar difficulties. Many railway men do not realize the expenditures which are being made by some of these companies for no other purpose than to educate those having to do with the application and use of special devices which have long since proved their value in locomotive and car service. The steam locomotive would never have attained its present position in this country had it not been for the far-sighted co-operation of the manufacturers of railway supplies, and railway men would do well to bear this in mind and receive the representatives of such companies courteously at all times; the time may come when their advice and assistance may be of incalculable value.

The Pennsylvania Test Department

Most of our readers are familiar with the results which have been obtained from time to time on the locomotive testing plant of the Pennsylvania Railroad at Altoona, as well as those obtained on the same plant at the St. Louis Exposition in 1904. Beyond the knowledge of these tests, however, it is doubtful if any great number realize the extent of the work conducted by this department, of which locomotive testing forms but a single branch. The broad scope of this work will, however, be more fully realized after a perusal of the authoritative description of the department and its activities, which is published in another part of this issue. From its humble beginning in 1874 the work of the department has increased at an average rate of over 100 per cent in each year till the number of routine physical tests conducted reached, in 1912, a total of 120,000, the carrying out of which required the services of about 300 employees. The cost of operating this department for one year, \$534,000 seems enormous, but the railroad has found it fully justified and indeed this is easy to understand when we consider the undoubted saving in lives and property which are the direct results of the rejection of defective material which would otherwise have been placed in service in cars, locomotives and structures. After all, the cost of conducting the department amounts to but 0.6 per cent of the material inspected and tested, and it may be seriously questioned whether any other road is obtaining anywhere near the same results at a cost even approximating this.

Two July Conventions

The eleventh annual convention of the International Railway General Foremen's Association will be held at the Hotel Sherman, Chicago, July 13-16, 1915, and the American Railway Tool Foremen's Association will hold its annual meeting at the same place, July 19-21. The programs for both of these conventions have been carefully worked up, and if the members will take an active part in the discussion of the various topics, giving their own experience and bringing out that of others, they will not only develop in-

formation of value to themselves, but will add also to the value of the published proceedings. The subject of Roundhouse Efficiency, which is to be discussed at the General Foremen's convention, while one upon which a great deal has been said both in the conventions of this association and elsewhere, is still deserving of the most careful consideration and discussion in order to help toward improved conditions. The difference between the best and the poorest roundhouse practice in this country is very great, and there is still room for much improvement in even the best practice. The possibilities of instructive and economical work in the tool room are brought out in a striking manner by an article elsewhere in this issue describing the methods in use on the Illinois Central. The author of this article is the secretary of the Tool Foremen's Association. Both of these conventions are worthy of a full attendance of shop, roundhouse and tool foremen, and the higher officers of the mechanical department should encourage their subordinates to be present and take part in the discussion.

Underframes Should Be Strengthened

We have repeatedly called attention to the serious condition of box car doors and roofs, which is such as to cause enormous damage to and permit of easy theft of lading from cars. The roof and door problems, however, are by no means the only ones confronting the car man. The underframe, which is the foundation of any car and the main portion of its structure from the standpoint of strength, is sadly neglected in very many cases. The heavy shocks incident to present day service conditions must of necessity be received directly on the underframe, and unless this part of the car's structure is sufficiently strong to withstand them, the body frame work is sure to work loose and the roof to buckle and spring apart at the joints, so that the car provides its lading with practically no protection from the weather. Although some of the cheaply-built modern cars are very serious offenders in this respect, the cars with wooden underframes are the cause of the greatest amount of trouble, and there would seem to be but one remedy, the application either of a full steel underframe or of steel center sills. In a considerable number of cases the latter method has been worked out satisfactorily, resulting in the cars being so strengthened that the cost of repairs and the time spent on the repair track has been greatly reduced. A number of roads have gone to the expense of providing an entire steel underframe on all their more recent wooden cars of higher capacity, and the expense of doing this work has been shown to be amply justified. A point which should be brought home to all concerned with the purchase of new equipment is that even a steel underframe, if improperly designed and poorly put together, will not withstand the shocks of present day switching service, and a reasonable expenditure is demanded in this part of the car structure in the interests of economical maintenance just as much as in the case of roofs and door fixtures.

Car Department Officers and Economy

Why do railway executive officers place experienced men in charge of the car department and then persistently over-ride their recommendations when it comes to purchasing new equipment and making appropriations for repairs? The higher officers who listen to and consistently follow the recommendations of the head of their car department are all too few and it is largely because of this that there are so many freight cars in service which are costing excessive amounts for maintenance. Many of these cars were built according to instructions from the higher executive officers to keep within a certain amount as to first cost, instead of following the recommendations of men familiar with car department conditions, who know that even a slight increase in first cost may mean, in an order of several thousand cars, the saving of an enormous amount in maintenance costs. If the advice of car department officers had been followed

in the past the car problem would not be what it is today, but still the policy persists, not only of providing cheap cars but also of providing grossly insufficient amounts for their maintenance. We realize fully that the conditions in railway operation at present require economizing on the part of everyone in every department; but no one can reasonably say that the purchase of cheaply constructed cars, which spend a large proportion of their time out of service undergoing repairs, is economical. When cars have to be purchased it would be far more to the railway's advantage to employ the same amount of money in purchasing a smaller number of well built cars. Such an expenditure would not only result in decreased maintenance charges but in all probability in increased earnings from the cars purchased, because of their ability to make a greater mileage per year. This is one of the numerous points upon which car department officers are qualified to speak and their advice should be given greater consideration by those higher in authority than it now is in many instances.

Consolidation of Mechanical Associations

In his opening address at the June convention of the American Railway Master Mechanics' Association, President F. F. Gaines said, in referring to the possibility of combining all the various mechanical associations in one: "I think that the time has now come when we should have, under whatever title we may choose, one organization only, divided into such sections as may be found advisable. Most of the members of the various associations come under the jurisdiction of the mechanical department of a railroad. It would seem not only advisable but very desirable that some such new association should be formed to take over to a certain extent control of all the others. They need not necessarily meet at the same time; in fact I think it would be better to spread the meetings out as at present, but the executive committee of the supreme association should pass upon the work of the minor associations." Because we feel that this is a matter in which all railway mechanical associations are vitally interested, and that it should be brought plainly to the attention of their officers and members, we wish to repeat a portion of an editorial on this subject which was printed in the *Daily Railway Age Gazette* for June 16, 1915: "Whether a governing body directs the work of the association or a general mechanical association is formed, the different sections meeting together or separately, as the conditions at the time may warrant, is a matter for discussion. There can be no question, however, as to the desirability or even necessity of taking some measure immediately to secure greater co-operation on the part of all of the railway mechanical organizations. This has been realized for a long time, and we have consistently advocated it in our columns. The minor mechanical associations are doing excellent work, yet in the majority of cases they feel the need of more recognition from the larger associations, and would undoubtedly be glad to work with them with the idea of going thoroughly into the details of those questions with which they are most familiar, and making definite recommendations to the major associations for approval and adoption as recommended practice or standard." The actual working out of any such plan could, of course, be determined upon only after careful consideration at representative conferences, but there does not seem any good reason why the various associations should not retain their individuality to a considerable extent, while the centralized control suggested by Mr. Gaines should be the means of eliminating much of the duplication which now occurs, particularly in the minor associations. We believe that the matter of consolidation, or at least of the closer affiliation of all the mechanical associations, should be given careful consideration by their entire membership, for that the requirements of increased efficiency in railroad work demand some such rearrangement there can be no doubt.

Refinement in Locomotive Design

We have had a great deal to say in these columns concerning the refinement of American locomotive design. Much has been said on this subject along the lines of reducing the weight of reciprocating parts by the use of heat-treated and alloy steels. But it must not be thought that the use of special material in order to save weight by the employment of light sections constitutes the only refinement possible in the designing of locomotives. If results comparable with those obtained in Europe, and in some special instances in America, are to be obtained the refinement must be carried out in the design of the entire locomotive. Too much has already been done in the way of increased power merely by increasing the weight. We have nothing to say against the large locomotive, provided it is capable of producing power proportionate to its size and weight; but we have too many cases of locomotives built with very large boilers to insure ample steaming capacity and every other part of the locomotive built proportionate in size, the line of least resistance being followed in obtaining strength, by the simple process of adding metal. The addition of metal in order to gain strength is not what is wanted, but the designing of the various parts so that they will have ample strength at the points where the greatest stresses occur while at the same time there will be no unnecessary metal employed. This line of procedure is absolutely necessary if the weight of locomotives is to be kept in proper relation to the power which they can develop. Furthermore, the adoption of a boiler of large dimensions does not of necessity make it the best boiler for the particular service. Refinement is needed in boiler design as much as in the design of other locomotive parts. Particular attention should be given to the provision of a grate and firebox of the best proportion considered in relation to the boiler as a whole, and to the power requirements of the locomotive. Much of the waste of fuel which it is now the effort of all railway mechanical men to prevent as far as possible, could be avoided if the boilers and fireboxes of some of the locomotives now in service had been properly proportioned when the engines were designed. There are enough locomotives now in service in this country in which refinement has been carried out in the design of every detail to indicate plainly that we need not be behind Europe in the matter of producing a horsepower with the least expenditure of water and fuel and the smallest amount of dead weight.

NEW BOOKS

Proceedings of the American Institute of Electrical Engineers. Bound in paper. 390 pages, 6 in. by 9 in. Illustrated. Published by the American Institute of Electrical Engineers, 33 West 39th street, New York. Price \$1.00.

This is the May number of the Proceedings of the American Institute of Electrical Engineers, and contains a number of interesting and valuable papers. These include papers on direct current control for hoisting equipment in industrial plants, the classification of alternating current motors, provisional specifications for insulator testing and many others. The book is well illustrated, the half-tone illustrations being on special coated paper and of a particularly high order.

Resuscitation. By Charles A. Lauffer, M.D., medical director, Westinghouse Electric & Manufacturing Company, East Pittsburgh, Pa. 90 pages, 4 in. by 6½ in. Bound in cloth. Published by John Wiley & Sons, Inc., 432 Fourth avenue, New York. Price 50 cents.

This book originally appeared in 1913, and it has met with such favor that a second edition has now been published. It deals with the resuscitation of persons whose respiration is suspended either from electric shock or asphyxiation from various causes frequently met with under modern conditions. It gives a complete outline of the so-called prone pressure method of producing artificial respiration, which is considered the best

manual method of resuscitation, in that it may be carried out by one person without assistance. The process is comparatively simple, and a thorough understanding of it by all persons employed in work subjecting them to the possibility of electric shock or asphyxiation would undoubtedly be the means of saving many lives which are lost during the interval required to call a doctor or secure mechanical means of resuscitation.

University of Illinois Bulletins. Bound in paper, 5½ in. by 9 in. Published by the University of Illinois Experiment Station, Urbana, Ill.

This is volume ten of the bulletins issued by the Engineering Experiment Station of the University of Illinois, most of which are noticed from time to time in these columns. This volume contains bulletins 68 to 74 inclusive, the subject of No. 68 being The Strength of I-Beams in Flexure, while that of No. 69 is Coal Washing in Illinois, No. 70 the Mortar Making Qualities of Illinois Sand, No. 71 Tests of Bond Between Concrete and Steel, No. 72 Magnetic and Other Properties of Electrolytic Iron Melted in Vacuo, No. 73 Acoustics of Auditoriums and No. 74 The Tractive Resistance of a 28-Ton Electric Car.

Machine Shop Management. By John H. Van Deventer, M.E., associate editor, American Machinist. 365 pages, 4 in. by 6¼ in. Illustrated and indexed. Bound in flexible leather. Published by the McGraw-Hill Book Company, Inc., 239 West 39th street, New York. Price \$2.50.

This is the first edition of a handbook, which it is stated has been written with the definite purpose of making available to all machine shop executives and men in training for machine shop executive positions a useful book on the study and solution of problems in management. Matters pertaining to organization are considered and committee plans and suggestion systems as well as apprenticeship are described. The functions of the drafting department are taken up and a section is devoted to equipment control, which is considered under such heads as the selection of equipment, machine location and the arrangement and standardization of machines and tools. Other sections deal with matters pertaining to quantity and quality, time keeping, rate setting, compensation and wage methods, etc., as well as traffic control and the causes of delay in shipment. The last section of the book is devoted to shop hazards under such heads as safety, mechanical safeguards, fire prevention and sanitation. The book is printed on thin paper and is of a handy size for carrying in the pocket.

Oxy-acetylene Welding and Cutting. By C. H. Burrows. 134 pages, illustrated, 6 in. by 9 in. Bound in cloth. Third edition. Published by the Vulcan Process Company, Minneapolis, Minn. Price postpaid, \$1.50.

Two editions of this book have already appeared, and in the third a number of revisions have been made. It is not intended as a comprehensive treatise of a technical nature, which would necessarily include a large amount of material of little practical use to those whose only requirements are the ability to properly handle the apparatus and the skill to successfully perform the various operations to which the oxy-acetylene flame is adapted. Only such theoretical matter has been included as is necessary to a clear understanding of the action of the oxy-acetylene flame and of the appliances usually met with in welding plants. Three chapters are included on the chemistry of acetylene combustion and the physical laws of gases, together with a brief consideration of the units of heat measurement and the expansion of metals. Aside from a brief chapter on metals and their properties the remainder of the book is devoted entirely to practical matters, including descriptions of the various appliances used in gas welding and cutting. At the close of the book are a number of useful tables, several of which deal with the cost of oxy-acetylene welding and cutting. The book was originally prepared for the instruction of users of Vulcan equipment, but much of the material which it contains is of general application.

PENNSYLVANIA RAILROAD TEST DEPARTMENT

The New Physical and Chemical Laboratory at Altoona and an Outline of the Extent of the Work

BY C. D. YOUNG

Engineer of Tests, Pennsylvania Railroad, Altoona, Pa.

Endeavoring to promote the safety of passengers and employees on its lines by minimizing or eliminating, if possible, all accidents traceable to defective or unsuitable material, the Pennsylvania Railroad has found that the quality of the material purchased for use in rails, bridges, cars and locomotives must be carefully scrutinized. Control over the quality of supplies is secured by the aid of specifications, which are based upon careful consideration of the materials available for the various uses of the railway, and by research work tending toward the development of new materials and devices, or improving those which are in general use. Neither the reputation of the manufacturer nor a superficial inspection of the materials offered has been found to be a sufficient safeguard in the purchase of supplies, since frequently the manufacturer himself has no positive knowledge of the strength or other physical properties of the iron, steel or other metals, nor the purity of many of the articles offered for sale.

An organization with laboratories at a central point is an essential in promoting the work of thorough inspection, the importance of which is unquestioned. With this inspection, accidents to the traveling public and the employee have been reduced, and efforts in the future will be towards their further reduction. It is desirable, therefore, that the public be fully informed as to the facilities provided by one of the largest railroad companies for making tests of all its supplies and conducting investigations with a view of obtaining the best materials which can be commercially furnished.

The Department of Tests of the Pennsylvania Railroad—the first of an American railroad—has grown in the following way:

In 1874 there was established at Altoona, a department of physical tests, the organization of which was placed under the direction of Theodore N. Ely, then superintendent of motive power. The first testing machine was purchased during the early part of the year. It was of 50,000 lb. capacity and was furnished by Fairbanks and Ewing. The first test was made on April 2, 1874.

In the beginning, the testing work was conducted by the master mechanic of the Altoona shops, but in August, 1874, the department of physical tests was placed in charge of John W. Cloud, who became the first engineer of tests. A chemical laboratory, under the direction of the late Dr. Charles B. Dudley, was added in the autumn of 1875. Research work for the improvement of rails was begun, and the investigations and accumulation of experience, which later made possible the preparation of a series of "Standard Specifications," had their start.

It was not until 1879, or five years after the beginning of the testing of materials, that the physical and chemical departments were provided with a separate building. This building was a one-story frame structure, 25 ft. by 45 ft. These quarters were soon abandoned, however, and until 1914 space was made available in a part of the shop office and storehouse building, where the departments finally occupied 15,476 sq. ft. of floor area on four floors. That the growth of the departments has been rapid is also evidenced by the diagram, which shows the number of employees, the number of routine physical tests, and the number of standard specifications in force for each year from 1874 to 1914. The quarters having become congested in the past few years, a new building with a floor area of 41,000

sq. ft., was begun in 1913 and completed in 1914. Thus, in 35 years the requirements of the departments, as shown alone by the floor space occupied, have increased more than 35 times; or, there has been an average increase of over 100 per cent for each year since the work began. The growth of the test department and laboratory has been very much more rapid than the increase in tonnage hauled, or the extension of the general business of the railroad. The reason for this is that there was almost as wide a field for the application of specifications, and the inspection and testing of materials, in the beginning as at the present time.

THE NEW BUILDING

The new building at Altoona which has just been occupied is constructed of reinforced concrete, the reinforcement being of twisted bars. Structural steel cores are used in the con-

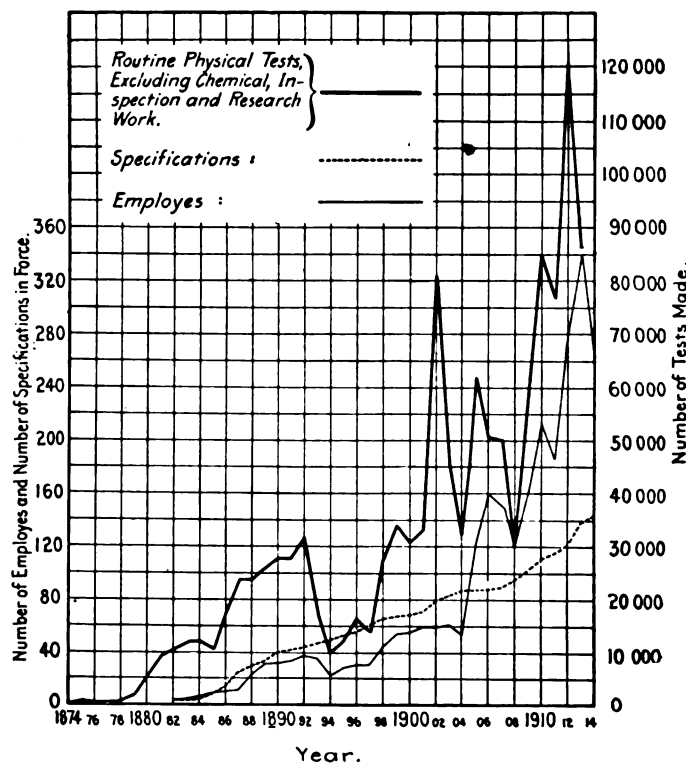

Growth of the Department of Inspection and Tests on the Pennsylvania Railroad

crete columns. The whole exterior is finished in red brick and red terra-cotta. It is arranged with a central service portion consisting of the middle bay which contains a stairway and an electric elevator, giving access to all parts. On the basement floor of the service section there is a receiving room for materials. This room communicates with the elevator for the distribution of small samples to the different sections of the building, while large pieces may be lifted to the physical-test section by means of a ten-ton traveling crane with a hatchway in the main floor. There is a machine room in the basement and in this all of the metal test specimens are prepared. On this floor there are two large fireproof vaults for the storage of letter files and the like, and a room for chemical stores.

*From a paper read at the annual meeting of the American Society for Testing Materials, Atlantic City, N. J., June 22-26, 1915.

The first or street floor is devoted to physical tests. It contains a physical laboratory with five universal tension and compression testing machines, the largest of which has a capacity of 1,000,000 lb., and all are served by the traveling crane. On this floor are separate sections for oil, cement and lagging, hose, rail, miscellaneous and heat-treatment tests.

The second floor is used for office, locker and toilet rooms,

Direct lighting with tungsten lamps is the system of illumination. "Abolite" metal reflectors are used in the basement and on the first floor, with "Pyro" glass reflectors on the second or office floor. In the chemical laboratory, where metal would be injuriously acted upon by gases, "Holophane" glass reflectors are in use. All of the lighting and power conduits were placed in the floors before pouring the concrete. Tele-

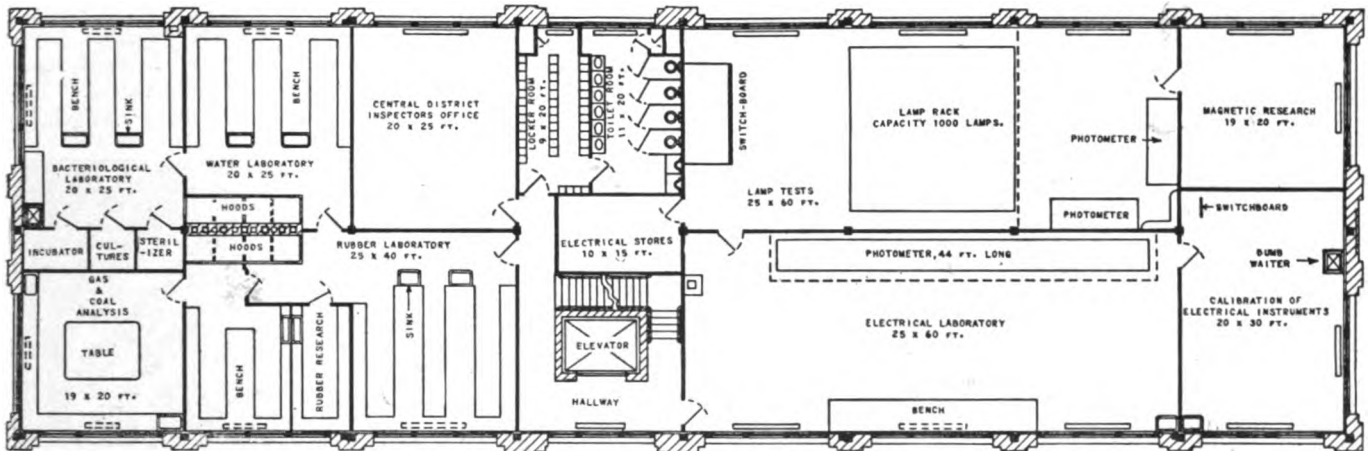

A Typical Floor Plan in the New Building; This is the Third Floor

the south end being occupied by the office force of the engineer of tests and the north end by that of the chief chemist.

The third floor is divided into laboratory rooms for bacteriology, rubber, water and gas analyses, photometry and lamp tests, and the calibration of electric instruments.

The whole fourth floor is used as a general chemical labo-

phone, dictaphone and buzzer systems are installed in the floor conduits, and in addition great flexibility is possible in the location of these fixtures by the use of a chair rail around the walls of each room, the chair rail having three separate grooves for wires.

The building is heated by direct steam radiators with a single pipe system, and the radiators are placed under the windows. A hot water service, with a heating and circulating tank in the basement, is provided. The gas, steam, air, water and hydraulic lines are of open work, and all pipe risers are in a common conduit in the central service bay of the building.

The interior of the building is finished in natural chestnut throughout, with the exception of the office rooms, which are finished in imitation mahogany. All interior doors and partitions are glazed. The floors, with the exception of the basement where the floor is of concrete and the physical laboratory where it is of wood on concrete, are of magnesium-cement composition.

It is noteworthy that the building was constructed and equipped complete within the original estimates and appropriation. The building itself cost about \$150,000. An estimate of the value of the contents is, for the physical laboratory, \$100,000; and for the chemical laboratory, \$25,000. With equipment complete, the investment is about \$275,000.

PHYSICAL LABORATORY

Among the machines and apparatus that compose the equipment of the physical laboratory, there are the following:

- Five universal tension and compression testing machines, one of 1,000,000, two of 300,000, two of 100,000-lb. capacity;
- One vibratory endurance spring testing machine of 75,000-lb. capacity;
- One 43-ft. drop-testing machine;
- Two vibrating staybolt testing machines;
- One Brinell hardness testing machine;
- One 2,000-lb. cement testing machine;
- One horizontal microscope, with camera for metallographic work;
- One grinding, buffing and etching outfit for the preparation of samples for microscopic work.

In the machine room, where the sample test specimens are prepared, the following tools are used:

- Two 14-in. engine lathes;
- One 12-in. drilling lathe;
- One 24-in. shaper;
- One 24-in. radial drill;
- Two milling machines for specimens;
- One 30-in. cold saw;
- Two motor hack saws;
- Two tool grinders.

For the work in testing air brake, signal and tank hose and

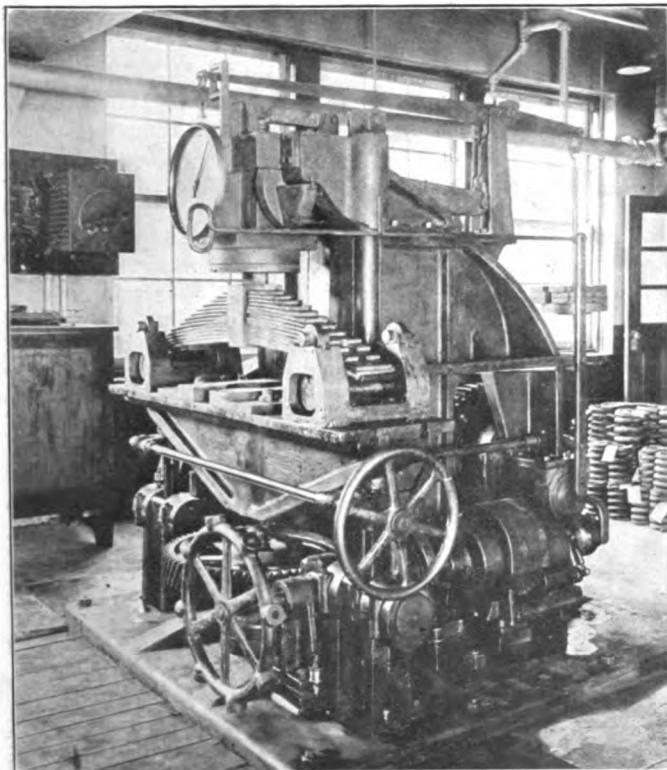

Spring Testing Machine

ratory with a separate chemical balance room. The central bay is extended up to form a fifth floor, which comprises a photographic studio and dark room, while the roof of the remaining portion of the building is used for experimental work and tests where exposure to the atmosphere is required.

other miscellaneous tests including steam and hydraulic gages, there are:

- Six rubber stretching machines;
- One friction test rack for rubber;
- One hose mounting machine;
- One vibrating test rack for hose;
- One continuous test rack for rubber;
- Four tension testing machines for rubber;
- One stretching machine for rubber insulation;
- One spring micrometer machine;
- One vacuum gage testing machine;
- One arbor press specimen cutter;
- One hydraulic gage testing machine, capacity 25,000 lb. per sq. in.;
- One dead-weight gage testing machine, capacity six gages;
- One wigling testing machine for hose;
- One bumping testing machine for gages;
- One whipping testing machine for gages;
- One hydraulic machine for testing gage glasses.

The materials for test, including samples which have been obtained by the inspectors at outlying points and those sent to the department by the shops, are brought into the building through the receiving room. They are distributed throughout the building from that point, the metal specimens going to the machine room in the basement for preparation, then to the physical laboratory for tension, compression, vibratory or other tests, and to the chemical laboratory for analysis.

Rubber, Air Brake Hose and Miscellaneous Laboratory.—The extent of the work of this department is indicated by the fact that the needs of the railroad are about 635,000 pieces of air brake hose per year. There are now being installed ma-

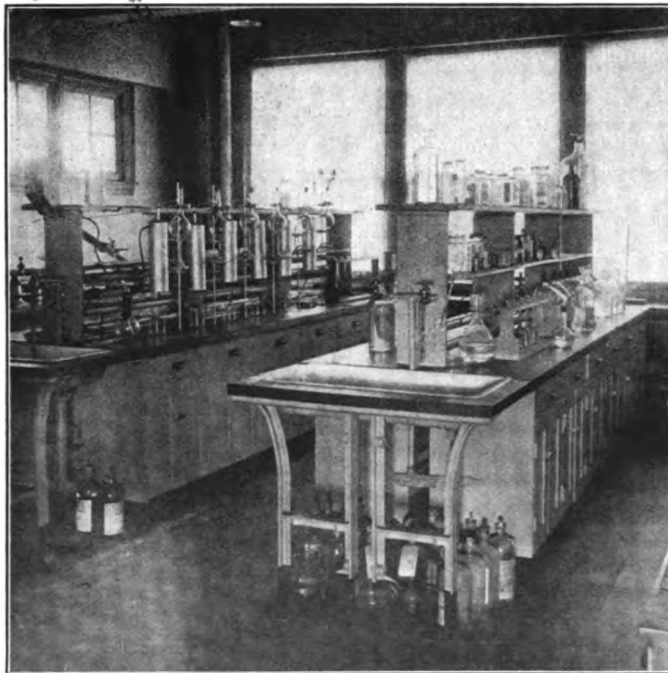

Water Laboratory, Where Chemical Examinations Are Made of Drinking and Boiler Feed Waters

chines for air brake, signal and tank hose, and other miscellaneous tests, including steam and hydraulic gages, and gage glasses for boilers and lubricators.

Heat-Treatment Laboratory.—This department, on the first floor, is for the development of standards in the heat-treatment of metals during the process of their manufacture for use in railway equipment. Investigations are carried out to study the effect of various heat treatments on a large variety of carbon and alloy steels. They are also made to determine the properties of non-ferrous alloys, including the co-efficient of expansion. Shop-manufactured locomotive and car springs, involving as they do a form of heat-treatment, are sampled and tested regularly to determine their acceptability for service.

Large castings of various kinds have been heat-treated by this department with the aid of outside facilities with a gratifying degree of success. The effect of chemistry and heat-treatment upon the endurance of materials subjected to repeated stresses is tested out by revolution and vibration tests, including vibration tests on complete springs. Rails, splice bars and tie plates are heat-treated to study the increased service it is possible to secure. The effects of heat-treatment are noted and a wide range of working conditions are applied on a variety of high speed tool steels to ascertain the best chemical characteristics.

Investigations are made on various types of fireproof material for the purpose of maintaining a high standard. The testing of felt and insulating papers used for lining refrigerator

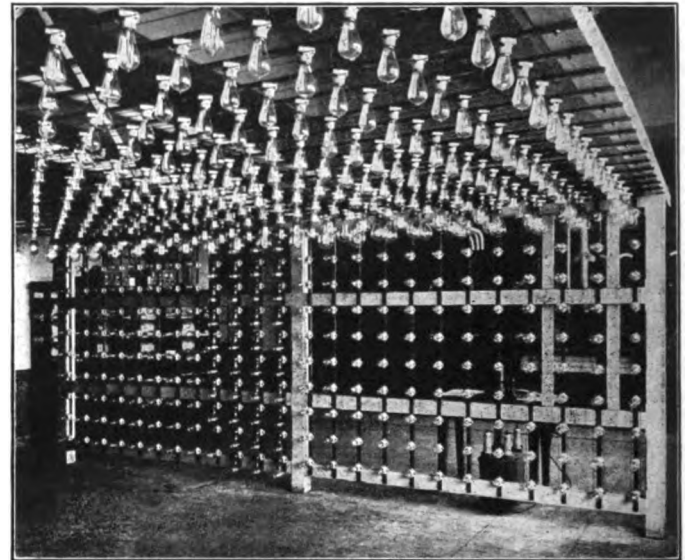

Lamp Test Rack with a Capacity of 1,000 Lamps

cars has been made necessary by the large variety of materials of this kind on the market, the keen competition among manufacturers, and the ease with which the highest grade and best material can be closely imitated by cheap and inferior products. This laboratory is equipped with an insulated room and electrical heating arrangements for this work, the tests being designed to represent as nearly as possible the service conditions to which these materials would be subjected. Temperature measurements are made of various types of refrigerator-car construction by means of resistance thermometers. Aside from the measurements of high temperatures in the laboratory, periodic calibrations are made of the various pyrometers. The heat-treatment department in general carries on a large variety of special work, and there is but little that falls without its range of possibilities even to the extent of heat-treating glassware.

ELECTRICAL LABORATORY

Lamp Tests.—On the third floor the equipment for lamp tests consists of three photometers, a lamp test rack of 1,000 lamps capacity, with switchboard, transformers and potential regulator equipment. This work was taken up in 1902, with a view of obtaining data for the preparation of specifications to secure uniformity in the ordering of incandescent lamps, and the maintaining of sufficiently high standards. It consists mainly of life tests of lamps at abnormal voltages and tests for the efficiency of illumination, as well as the investigation of new developments in the general field of illumination as applied to railway work.

Standardization of Instruments.—A division of the electrical laboratory is employed in investigations and development work along electrical lines, and the standardization of electrical instruments. Part of this work is done at the laboratory, and part of it, when necessary, at other points, by laboratory men.

The character of the work may be judged from the following examples upon which comprehensive reports have been made:

- An investigation of electrolysis in systems of underground metallic structures;
- Tests and investigations of the construction of various makes of transformers;
- Tests of various makes of primary and secondary battery cells;
- Oscillographic tests for linear and angular velocity, wave forms, etc.;
- Investigations of special cases of electrical troubles;
- The development of an electrical method of measuring the hardness and homogeneity of steel.

Matters such as these are reported on and recommendations made. Electrical instruments are sent in from all points on the Pennsylvania system to this department for calibration and re-

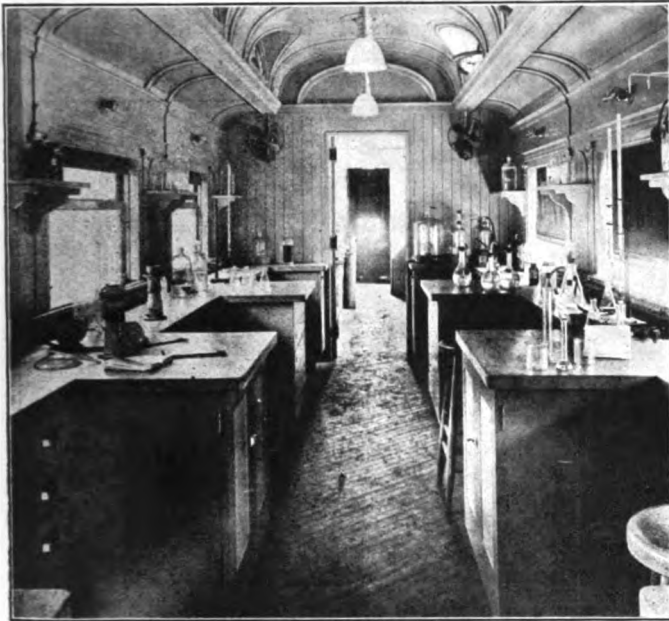

Interior of the Laboratory Car

pair, and men from the laboratory are sent out to inspect and check electrical instruments on switchboards at the various power plants, and at other points.

LABORATORY AND ROAD ASSISTANTS

A large room on the second floor is provided for the force of laboratory and road assistants coming under the direction of the foreman of road tests and special tests. The duties of these men are varied, and include tests of locomotives on the road or tests of equipment with special devices; the tonnage rating of trains and the following up of all experimental appliances which are put into service for test purposes.

The fifth floor has been arranged for photographic work, consisting largely in making prints of metal sections, photomicrographs of steel rails forming a large part of these. Photographs of parts which have failed in service are also made for convenient preservation and study. The photographic work requires the services of two men and about 25,000 prints per year are made.

CHEMICAL LABORATORY

Metallurgical Work.—The main chemical laboratory on the fourth floor is divided by the central balance room, into two departments, the larger one of these being devoted exclusively to metallurgical chemistry. In this department methods are developed for the determination of the elements in plain-carbon steels, alloy steels, and non-ferrous alloys used for bearing backs and linings, packing-ring metal for different purposes, etc. Data are obtained leading to the development of specifications for this class of products, and samples of shipments are analyzed to determine whether they are acceptable under the

specifications adopted. This steel laboratory has facilities for analyzing 100,000 samples per year.

Miscellaneous Work.—The smaller of these two laboratories is for work of a more general character, being used for the examination of fuels, the development of specifications for paint products, lubricating and burning oils, boiler compounds, lacquers, plush, car cleaners, cutting compounds, belt dressing, polishing compounds, hydraulic-jack liquids, fuses, track caps, fire-extinguishing preparations, the recovery of used or wasted products, etc.

In both of these laboratories much time has been spent in the examination of broken or "failed" parts of equipment, in an effort to determine the cause and with a view to the prevention of accidents which aside from the money losses, might result in injuries or loss of life.

Certain food products used in the dining car service are also examined here at times; many other miscellaneous investigations are made, as of conditions which may have led to loss from the damage of freight in transit, and to so establish methods for preventing such loss. During the past year a considerable amount of work has been devoted to the chemistry of tunnel air in connection with the installation of ventilating systems. The total list of activities touched upon would be too long for enumeration in an article of this character.

The chemical analysis of rubber compounds has been studied and much experimental work done in perfecting a method whereby material of this kind can be bought on specifications which define and limit its chemical properties. At present there is in force a specification for high-grade rubber insulation. Samples from all shipments are analyzed, as well as some other rubber

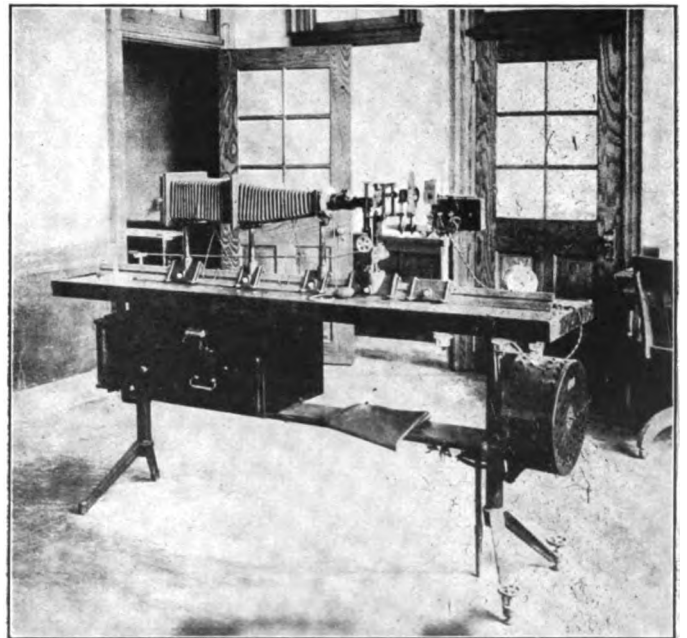

Metallographic Laboratory

compounds. At the same time experimental work is being carried on to improve the method of analysis, and to devise others so that specifications may be drawn covering the chemical properties of other grades of rubber materials.

Manufacturing Laboratory.—A manufacturing laboratory, which might be called a small factory, is maintained in a separate building which is under the direct supervision of the chief chemist, and new products are manufactured in this until such time as it is found advisable to purchase them from "outside" manufacturers.

Laboratory Car.—In addition to the steel-rail work at Altoona a laboratory car has been built to be moved, as required, to that point where steel rails in process of manufacture are to be

inspected. The object in equipping this car is to make chemical analyses of the finished rails at the mills by a force of chemists under the chief chemist. This, it is expected, will avoid delays which at times occur in the operation of the mills, and are impossible to avoid without the facility of a suitable force at hand at the time and when the rolling is taking place, in order to keep up with the chemistry requirements of the company's specifications. The car is equipped with furnaces for combustion and all other necessary apparatus for general chemical work in connection with the inspection of steel rails.

Bacteriological Laboratory.—When the department of chemistry was established, problems were frequently presented which applied chemistry could not solve satisfactorily. It was found, for example, that a chemical examination of water might show the presence of organic constituents, but it was impossible to tell the source of these. A water might contain a large amount of organic material of vegetable origin and yet not carry any infec-

The work in bacteriology and water analysis has increased constantly, and at the present time four men are employed in the laboratory. The department co-operates with the surgeon general of the United States in the enforcement of the quarantine regulations of 1913, which require that railroad companies shall furnish wholesome drinking water and proper ice supply to passengers using their cars. Water which contains anything indicative of injurious contamination is not permitted to be introduced into the drinking containers of a Pennsylvania coach.

The department regulates the standardization of disinfectants and issues instructions concerning their application for the protection of passengers and employees, as well as the disinfection of stock cars. Special care is taken to prevent any infected employees from coming in contact with the public.

In 1914 bacteriological and chemical examinations were made of 609 samples of drinking water. There were 3,112 bacteriological examinations of pathological specimens, submitted by the

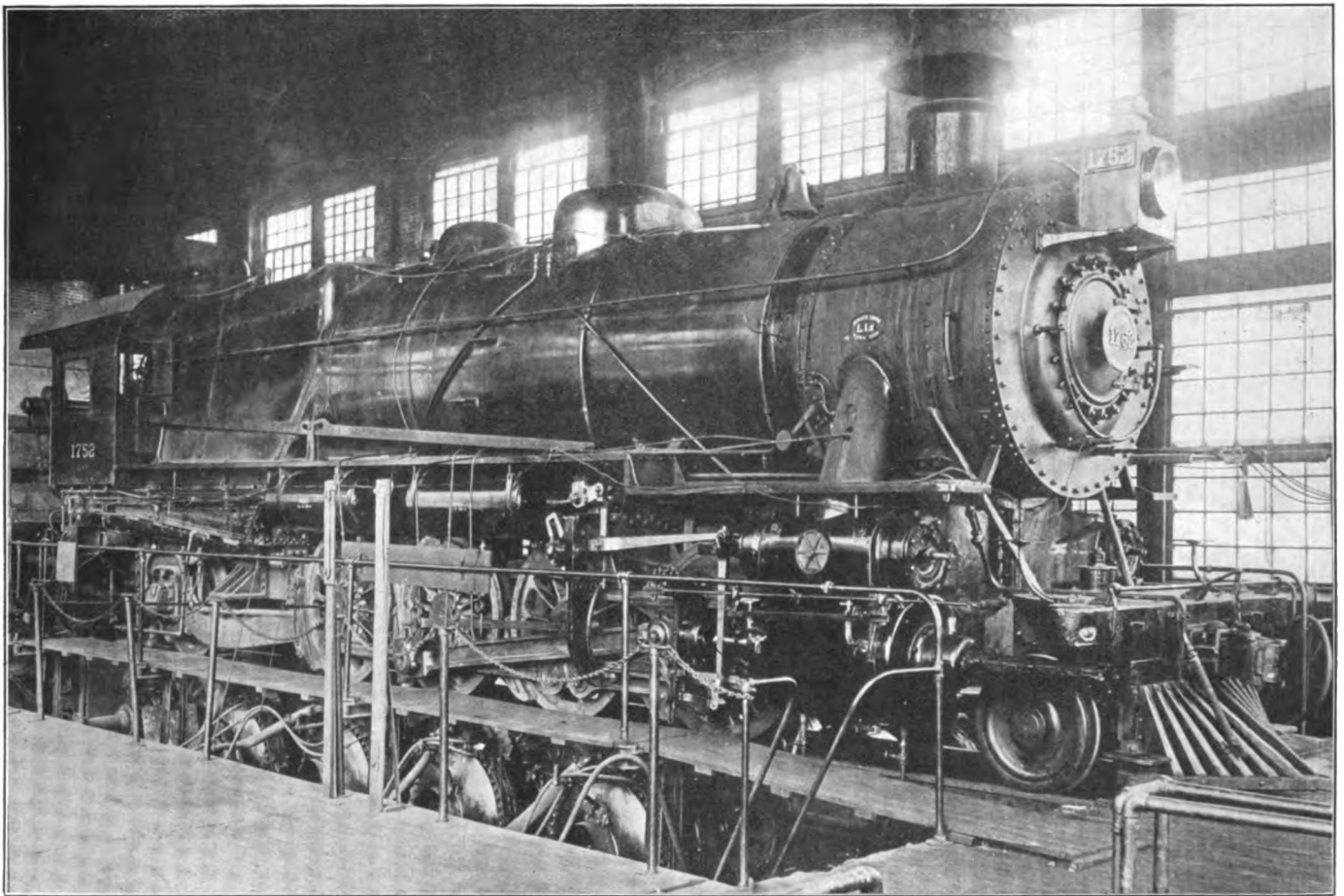

A Mikado Type Locomotive on the Testing Plant

tious material which would likely give rise to disease, while other samples low in organic constituents were believed to carry infectious germs which might render their use very dangerous to employees or patrons of the road.

It was also found necessary to supervise certain sanitary matters and to disinfect cars, offices and waiting rooms under certain conditions, but it was not known what disinfectants were destructive to specific disease-producing bacteria. Manufacturing concerns were offering various disinfecting preparations, but the officers of the company had no means of determining which ones were efficient and the problem could not be solved by chemistry alone. These questions were considered so important that it was decided that a division of bacteriological chemistry was necessary, and on November 1, 1899, such a laboratory was established.

relief association physicians. The total number of bacteriological examinations was 3,621, or an average of more than ten per day.

In addition, this department has under its care the examination of boiler feed waters and the formulation of methods for their treatment. In 1913, examinations of 287 boiler feed waters were made, while in 1914 the number was 282.

OTHER EQUIPMENT

As part of the equipment of the test department there is a dynamometer car which was built in 1906, and is the fifth of a series of such cars which have been in use on the Pennsylvania Railroad. There is also the locomotive testing plant which is located adjacent to the test department building. This plant was erected in 1905, after having been in use at the St. Louis Exposition in 1904, and is operated by a force of 26 men.

There is being installed in a separate building a brake shoe testing machine which will be the first of its kind, in that it will have two dynamometers of 4,000 lb. capacity, which will make it possible to obtain the co-efficient of friction of brake shoes when two shoes are applied to a single wheel (clasp brake conditions). The car wheel will run upon an idler wheel.

EXTENT OF WORK; AND ORGANIZATION

The scope of the work now embraced by these departments coming under the jurisdiction of J. T. Wallis, general superintendent of motive power, at Altoona, can be better appreciated when it is understood that the cost of the materials covered by the inspection and tests, and entering into the construction of the railroad rolling stock and track, in 1913 amounted to \$82,119,480, while the cost of operating the test department and chemical laboratory for the same year was \$534,060. For an approximation and using these figures, it is interesting to observe that the total cost of operating the departments, including all ad-

ples were analyzed, involving about 286,545 determinations. There are 85 items, ranging from asphaltum to zinc, which are now bought under specifications and which must be passed upon by the test department or the chemical laboratory.

During 1913 there were inspected, while building at manufacturers' works, 24,966 freight cars, 343 steel passenger cars, and 190 locomotives. The value of the materials rejected through the test department in 1913 was for the physical laboratory, \$776,928; and for the chemical laboratory, \$65,767.

As outlined in the diagram of the organization, the inspection at the manufacturers' works and the collection and forwarding of samples to Altoona is carried out under the direction of the chief inspector, with permanent resident inspectors and forces for the central district at Altoona, the western district at Pittsburgh and the eastern district at Philadelphia. In addition, when equipment is being built at outlying points, temporary inspection forces are maintained there during the progress of the work.

As previously stated, the work of the department began under

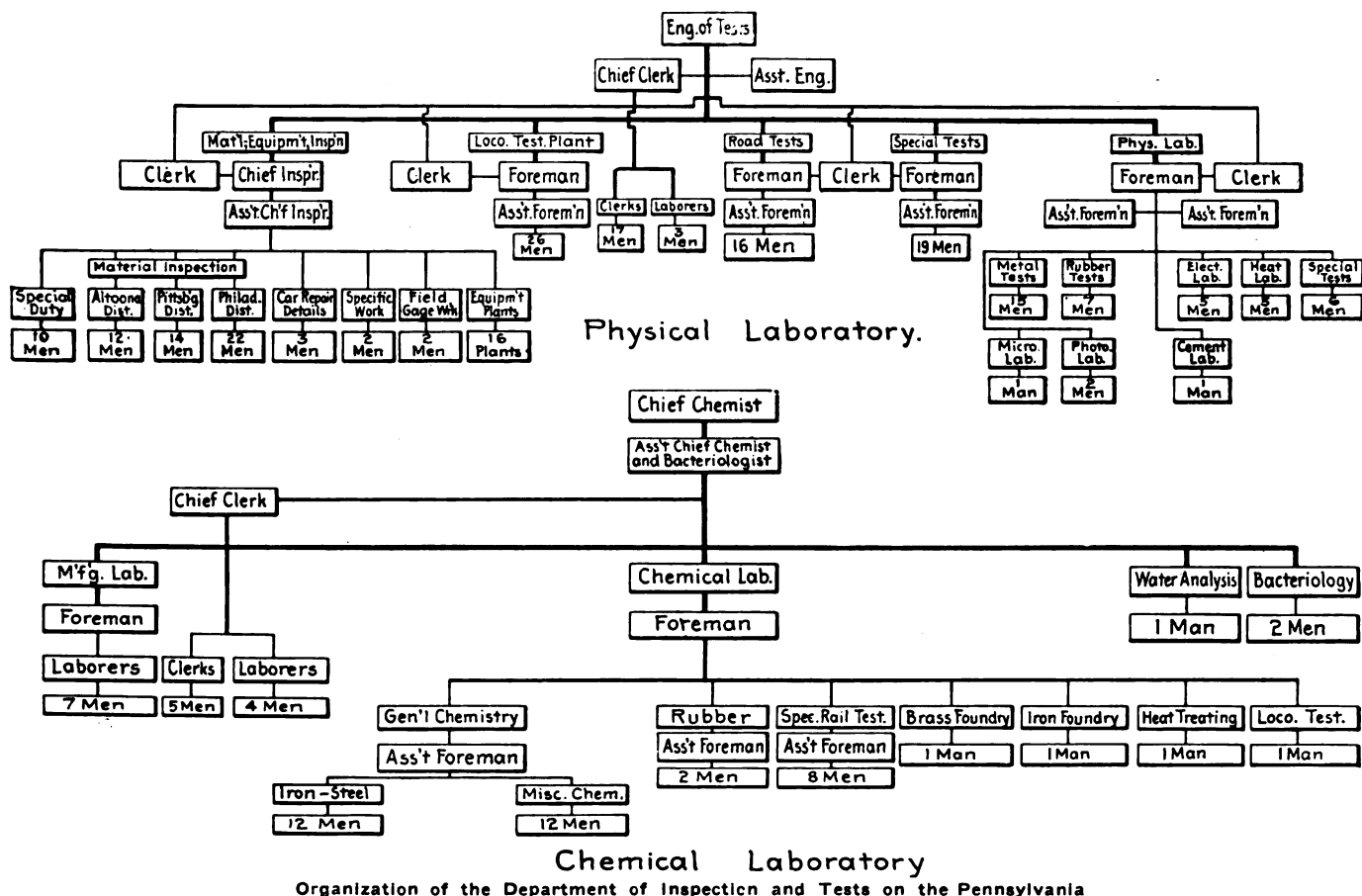

Organization of the Department of Inspection and Tests on the Pennsylvania

ditional work and inspection, is about 0.6 per cent of the cost.

The year 1913 was perhaps a record one for the test department and laboratory, and the extent and variety of the work of the departments can be shown by a few examples for that year. There were 61,148 separate reports of material tests issued by the test department. In the physical laboratory, while no record was kept of the number of samples examined, 138,886 tests were made, representing quantities as follows:

Of bar iron 149,863.63 lb. were tested and 6,246,611 lb. rejected; of staybolt iron, 15,385 tests representing 8,301,960 lb. were made; of cement, 29,231 tests were made, representing 587,900 bbl., of which 13,600 bbl. were rejected; of wheels, 310,381 were inspected, and 1,213 were rejected; of axles, 164,810 were tested and 8,035 were rejected; 250 samples, representing 56,322 yd. of push, were tested; of air brake hose, samples representing 634,807 were tested and 84,826 of these were rejected. In the chemical laboratory, during 1913, a total of 57,309 sam-

ples were analyzed, involving about 286,545 determinations. In May, 1879, he was appointed the first engineer of tests and continued under that title until July, 1886, when he succeeded to the office of mechanical engineer, retaining control of the test department. Axel S. Vogt, the present mechanical engineer, succeeded Mr. Cloud in March, 1887. The work of the department under the mechanical engineer was in direct charge of W. O. Dunbar from July, 1886, to July, 1893. From the latter date to July, 1903, the assistant mechanical engineer had direct charge of all the work of the department. During this latter period the assistant mechanical engineers were A. W. Gibbs, from July, 1893, to August, 1902, and W. F. Kiesel, from the latter date until July, 1903. In August, 1903, E. D. Nelson was appointed engineer of tests, and in September, 1911, was succeeded by the writer.

Two men have been in charge of the chemical laboratory, Dr. Charles B. Dudley from November, 1875, until his death, December 10, 1909; since then Dr. F. N. Pease has held the position.

EXAMPLES OF RECENT LOCOMOTIVES OF THE MOUNTAIN AND PACIFIC TYPES

ARRANGED IN ORDER OF TOTAL WEIGHT

Table with columns for Type, Name of road, Road number or class, Builder, When built, and various technical specifications (Tractive effort, Weight, etc.) and manufacturer details (R.I., C.&O., G.N., etc.).

* Equivalent heating surface = total evaporative heating surface + 1.5 times the superheating surface. † Includes arch tube heating surface. ‡ Railway Age Gazette, Mechanical Edition. § Boiler designed for 200 lb.

EXAMPLES OF RECENT LOCOMOTIVES OF THE MIKADO TYPE

ARRANGED IN ORDER OF TOTAL WEIGHT

Table with multiple columns listing locomotive specifications: Type, Name of road, Road number or class, Builder, When built, Tractive effort, Weight total, Weight on drivers, Weight on leading truck, Weight on trailing truck, Weight of tender, Wheel base, Wheel base total engine, Wheel base engine and tender, Diameter of drivers, Cylinders, Cylinders stroke, Valve gear, Steam pressure, Boiler type, Boiler smallest outside diameter, Tubes, Flues, Length of tubes and flues, Heating surface, Heating surface, firebox, Heating surface, total, Heating surface, superheater, Heating surface, equivalent, Grate area, Firebox length, Firebox width, Kind of fuel, Tender fuel capacity, Tender water capacity, Weight on drivers, Total weight, Tractive effort, Equivalent heating surface, Firebox heating surface, Weight on drivers, Total weight, Volume both cylinders, Equiv. heating surface, Grate area, Reference to photographs, drawings or description.

* Equivalent heating surface = total evaporative heating surface + 1.5 times the superheating surface. † Railway Age Gazette, Mechanical Edition. ‡ Boiler designed for 200 lb. † Includes arch tube heating surface.

CHARACTERISTICS OF PLATE SPRINGS

Part II*: Influence of Variables in Material and Construction Upon the Action of Springs; Design

By GEORGE S. CHILES

The experiments referred to in Part I had to do principally with springs which were all built or repaired in the same spring shop. It is advisable to consider briefly some of the variables effecting the construction of springs, it being reasonably evident that springs made in one shop may differ from those made in another shop, although the same specifications and drawings are followed in each case. Indeed, variations in workmanship may be found to exist in the same shop; two spring fitters working side by side and using the same grade of steel, may produce springs which give test results differing considerably from each other. This raises the question as to whether the test results from a number of springs may not vary to such an extent as to make impossible general conclusions relative to their actions in service.

In order to secure data which would settle this point and

sembled. Spring *C* was built in the same shop and assembled in the same manner but from steel rolled in a different mill. Spring *B* was built in a contract shop of the same material used in spring *A*. Although no data is available on this point it is assumed from a comparison of the curves taken when the springs were new that no lubricant was used between the plates of spring *B*. Spring *D* differs both in the point of manufacture

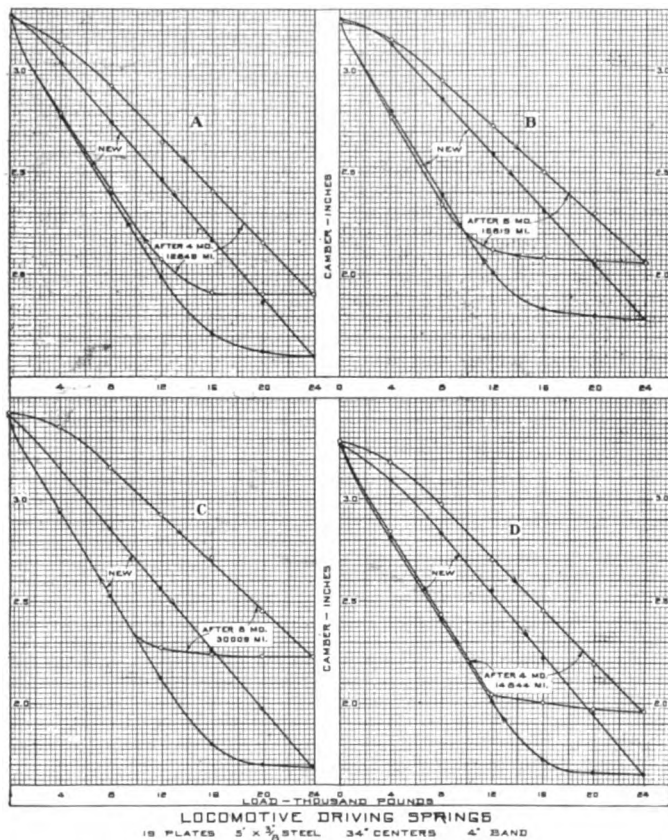

Fig. 12

determine the effect of possible variations in the quality of the steel, four similar springs were selected, each varying from the others either as to the place of manufacture or the source of the material used. These springs were applied to four Consolidation type freight locomotives of the same class, being located in each instance over the left No. 2 driver. After a few months' service, during which a record of the mileage was kept, the springs were removed and tested in the usual manner. The test curves are shown in Fig. 12. Spring *A* was built in a railway shop, the plates being painted with oil and graphite when as-

*Part I appeared on page 161 of the April, 1915 number and was concluded in the May, 1915 number, page 219.

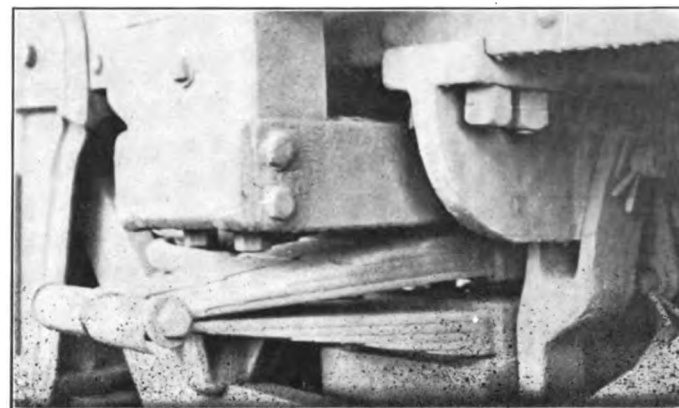

Fig. 13

and the source of material from all three of the springs previously mentioned.

It will be observed that the release load heights taken both before and after the springs had been in service approximate each other very closely. In contrast to the relative uniformity of these curves the heights for the applied loads differ considerably due to the stiffening effect of increased friction between the plates. It may therefore be concluded that variations in workmanship and differences in the source of material will have prac-



Fig. 14

tically no influence upon the future action of the springs as indicated by the release load curves of tests made at the time of manufacture.

The relation of the maximum fiber stress to which the material is subjected in service to the elastic limit of the material in the various plates has a large influence upon the future action of a spring. Both the fiber stress and the elastic limit of the

material may vary at different sections of the same plate or in different plates.

While the maximum fiber stress is ordinarily the result of the load carried by the springs it may occasionally be considerably augmented, due to the condition of the track, passing over cross-overs, running onto turntables, etc. The possibility of this augmentation may be clearly brought out by considering the effect of entering a turntable, the ends of the rails on which are higher than the connecting track, upon the springs of a six-wheel switch engine. The forward pair of driving springs on an engine of this type is often suspended independently of the second and third pairs, and in passing onto the turntable these springs may receive a large additional deflection above that due to the static load, with a correspondingly increased fiber stress. The writer also calls to mind a consolidation type locomotive which was fitted with short driving springs having but little deflection when under load. The fiber stress of these springs based on the static load was much lower than that in the springs on other locomotives of similar design which were longer and more flexible. Notwithstanding their greater relative strength

the best results may be obtained with a less flexible spring under main line conditions than on the branch line. Excessive flexibility, however, may result in rolling and consequent hard riding of the locomotive on the branch line. It must be borne in mind in any case that the action of the spring is effected by the design of the locomotive and the service in which it is to operate, as well as the type of spring suspension, and these points must be taken into consideration in designing the spring.

Steel may be tempered to such an extent that it will be hard, although it does not appear brittle, and will soon break in service. The failures of plates made of such material usually necessitate the immediate removal and replacement of the springs, with an undesirable service delay. On the other hand the treatment of the plates may be such as to leave the steel soft, in which case the spring may give trouble, not by breaking but by the gradual settling of the plates, which is in reality the taking of a slight permanent set. This action does not attract attention as frequently as does the breaking of plates, because it is gradual and may be prolonged over a period of several months. Whenever settling takes place to any extent, at least, a part of the plates have undoubtedly been stressed beyond the elastic limit. Since the maximum fiber stress to which the steel is subjected in service is a varying quantity, it may at times readily exceed the elastic limit, in which case there is a resulting tendency to raise the elastic limit and, not considering fatigue, the tendency of the spring to settle may thus in time be overcome automatically.

It has been advocated that an elliptic spring be constructed so that when the bands come in contact the fiber stress is

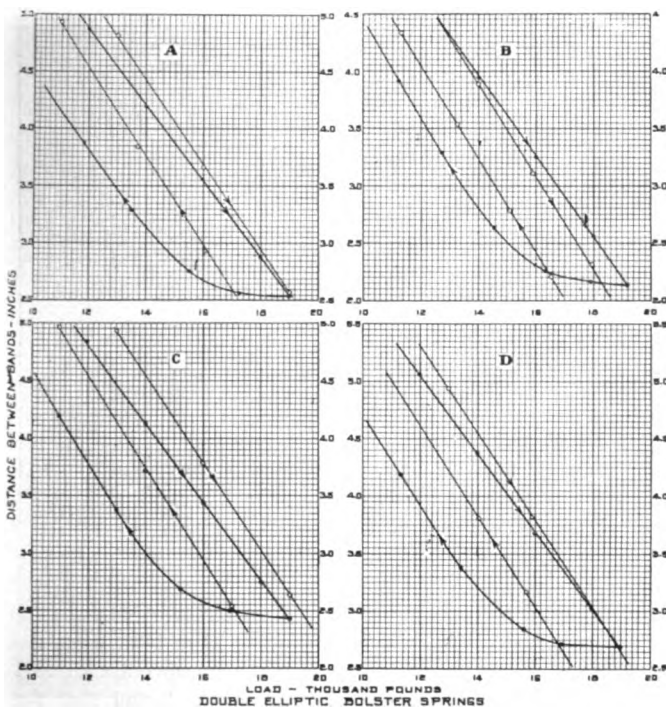

Fig. 15
 ○ PLATES $4\frac{1}{2} \times \frac{3}{8}$ STEEL $3\frac{1}{2} \times \frac{3}{8}$ BANDS
 LENGTH LOADED 48"
 —○— SPRINGS WHEN NEW-OIL AND GRAPHITE BETWEEN PLATES
 —●— SPRINGS AFTER 7½ MONTHS SERVICE

the less flexible springs were productive of the greatest number of failures. In order to reduce the trouble more plates were added to the springs, the result being an increase rather than a decrease in the number of failures. Of course the strength of the springs was increased since the fiber stress under the static load was lower, but the decrease in flexibility resulted in increasing the fiber stress for any given deflection beyond that corresponding to the static load. What was really needed was more flexibility which might have been secured by increasing the length of the plates or decreasing their thickness. In this connection it may be said that a large portion of spring trouble is mainly due to lack of flexibility rather than to lack of strength. The degree of flexibility permissible depends on service conditions. For instance a passenger car bolster spring may be made too flexible for service on a branch line where, owing to the poor condition of the track and roadbed the car has a tendency to roll, although the same spring might be entirely suitable for service under main line conditions. For a loco-

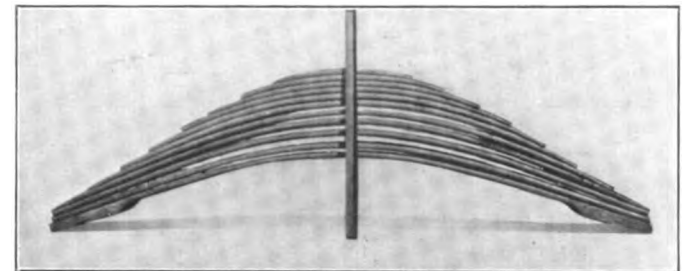

Fig. 16

below the elastic limit. Instances, however, have been observed where the distance between the bands is sufficient to allow a fiber stress 100 per cent or more in excess of that required to overstrain the steel, before the bands strike. These springs seem to give sufficiently satisfactory service, so that they are not removed, owing to the fact that they gradually settle in the manner outlined above without danger of bringing the bands in contact. While it may be desirable to so design springs as to make impossible excessively high stresses, carrying this practice too far may often necessitate the removal of springs because they have become solid much sooner than would have been the case had the distance between the bands been made greater.

The effect of the settling of springs differing in this respect is well illustrated in Figs. 13 and 14, both of which were taken from equipment in actual service. Fig. 13 shows a passenger car bolster spring and the amount it has settled may be seen from the distance between the top of the bolster and the truck frame. Fig. 14 shows a tender truck in which the bolster spring has settled until the bands are in contact.

The curves shown in Fig. 15 were taken from springs, the steel in which was evidently not tempered high enough for the service in which it was placed and shows the effect of subjecting material to a fiber stress in excess of its elastic limit. The springs from which these curves were plotted were in service under a passenger car seven and one-half months. They were assembled with oil and graphite between the plates and were

tested before being placed in service. A portion of the curves were plotted, the readings being indicated by the open circles. When removed from the car the springs were again tested, the readings being shown by the full circles. It will be seen that both the applied and release load curves obtained on the removal of the springs occupy positions considerably lower relative to those obtained from the new springs than do those shown in Fig. 12. With the exception of spring B the applied load curves taken after service are all below those taken before service, while instead of coinciding, the release load curves are widely separated. Otherwise the same general relation as to the relative slopes of the curves seem to hold, confirming the conclusion already indicated as to the effect of service upon the relation of the two sets of curves.

Whether springs are manufactured by hand or by the aid of the most improved machinery there is some difference of opinion as to the proper method of fitting the plates. It is generally the practice to bend each plate to a radius such that there will be "draw" or "tuck" between at least part of the plate when assembled for banding. The width of these openings varies and is often as great as $\frac{3}{8}$ in. or $\frac{1}{2}$ in. for the longer plates, decreasing as the plates become shorter. As shown in Fig. 16 a few of the shorter plates are fitted "dead" or without opening between them, especially in springs having a large number of plates.

When assembled in this manner it will be readily understood

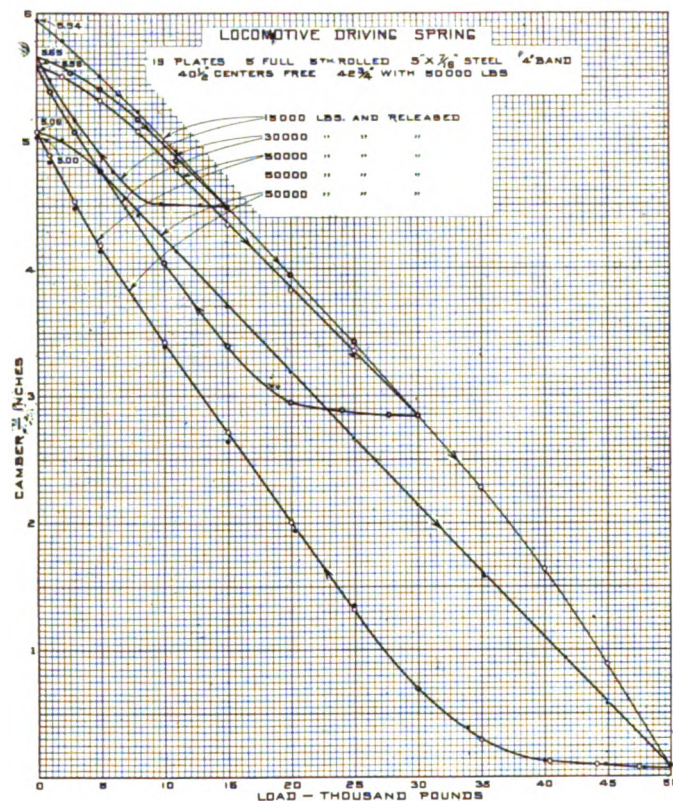

Fig. 17

that after being banded the curvature of each plate will have changed, the camber being different than it was before the band was applied. The camber of the longer plates is increased, while that of the shorter plates is decreased, the plates near the middle of the spring being the least disturbed.

In order to determine to what extent the different methods of fitting the plates would disturb the action of the spring a new 19-plate locomotive driving spring was fitted up in accordance with the practice just described, an unusually large amount of space being allowed between the longer plates in order to emphasize the effect and the shorter plates being fitted "dead." The total

distance over the plates at the center of the spring was measured with the spring in three different positions, the weight of the plates and the method of support accounting for the different values obtained. The distance over the plates with the long plates down and the spring supported at the end was $12\frac{1}{4}$ in.; the distance with the long plates down and the spring supported at the center was $11\frac{1}{2}$ in.; with the long plates up and the spring supported at the center the distance was $12\frac{3}{8}$ in. The total thickness of the plates was $8\frac{3}{8}$ in., thus making the total opening for the three methods of measuring $3\frac{7}{8}$ in., $3\frac{1}{8}$ in. and 4 in., respectively. The camber of each plate was

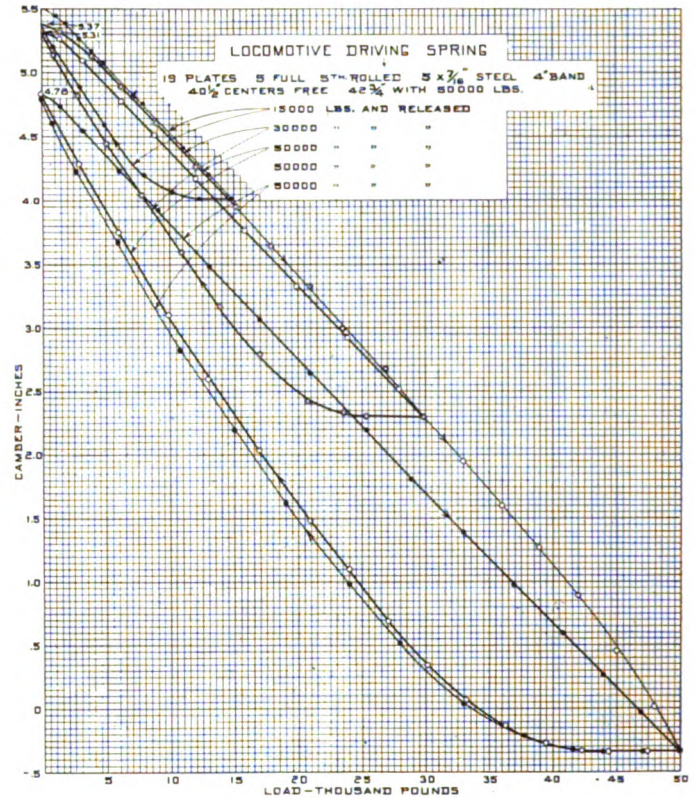

Fig. 18

recorded before the spring was banded. That of the main plate as tempered was 3.94 in., which was increased to 6 in. when the plates were brought together for banding, an increase of 2.06 in. On releasing the banding pressure it was found that the camber of the main plate was 4.05 in., an increase of .09 in. The plate was then jarred by holding it up and letting it fall, striking on its edge, but without decreasing the camber. This data secured, the spring was banded and tested. Contrary to the usual practice no preliminary load was applied to the spring, it being subjected to three successive loads of 15,000 lb., 30,000 lb. and 50,000 lb. respectively, with results as plotted in Fig. 17.

It will be noted that the camber of the spring after banding was 5.94 in., an increase in camber of 2 in. for the main plate. After the removal of the 15,000-lb. load the camber of the spring was 5.65 in., showing a decrease of approximately .3 in., which may be attributed to two causes: first, to the friction existing between the plates and second, to the straightening out of the shorter plates caused by the banding and loading. Both the banding of the spring and its load tend to straighten out the short plates, and it is possible that they may have been stressed to such an extent as to receive a permanent set. This would tend to reduce the camber of the spring as a whole. Attention is also called to the fact that the camber of the main plates under the 15,000-lb. load is approximately 4.5 in., which is still .56 in. greater than the original camber of this plate before banding.

The curve for the 30,000-lb. load passes through the maximum

load point of the preceding curve and returns to within .09 in. of its starting point, indicating a still further slight reduction in the camber of the spring. From the applied load curve it will be seen that when the load upon the spring amounted to 20,000 lb. the camber of the spring was equal to the original camber of the main plate before the application of the bands. It might be inferred that at this point the main plate was subjected to no stress. This is undoubtedly not true, however, since the camber of the plate was increased by taking a permanent upward set when the spring was banded.

Three applications of the 50,000-lb. load were made. The form of the first application curve beyond the maximum point of the 30,000-lb. curve indicates that the spring was taking a permanent set, and in order to obtain consistent results a second load was applied for which no values were recorded. The return of the release load curve to the initial point of the third application curve indicates that fairly constant conditions had been reached.

After this test was completed the spring band was machined off and the camber of the plates recorded. They were then reset and retempered, being fitted with a total opening between the plates of $\frac{7}{8}$ in. before banding. This was the minimum space that it was possible to obtain with ordinary care in fitting, being so slight that the increase in camber due to banding was scarcely perceptible. The spring was then tested under the same conditions and with the same loads previously used, the results being plotted in Fig. 18. It was thought that with the

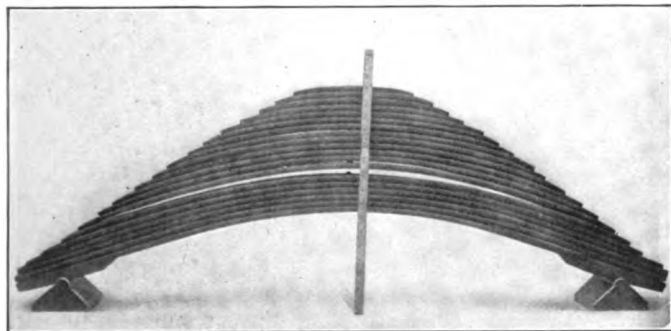

Fig. 19

plates fitted "dead" a spring would take a smaller permanent set than one fitted with considerable "draw" between the plates. The tests here recorded indicate that this is true up to a load of 30,000 lb., which is nearly 50 per cent greater than the load for which the spring was designed. The permanent set resulting from the 50,000-lb. load, however, shows practically no difference for the two experiments. The curves would seem to indicate that beyond a certain point the amount of permanent set taken by the spring is practically the same irrespective of the method of fitting the plates. It should be stated that the load of 50,000 lb. applied to the spring in this test is much greater than the spring will ordinarily be called upon to sustain in service.

Among shop men the opinion is generally held that springs built with openings between the plates are more flexible than those fitted with the plates "dead." This may be true to a certain extent for the reason that all of the plates are not uniformly stressed. Assuming, however, that such conditions exist at the outset, it is doubtful if an appreciable difference will exist after a few applications of an overload.

Upon the completion of the second test the spring band was machined off and the camber of the plates again observed. It was found that the relative position assumed by the plates after testing was practically the same in both cases, being as shown in Fig. 19, which was taken after the second test. It will be noted that while all the plates of the springs were in contact before the band was applied there is now considerable opening between the sixth and seventh plates. This division of the spring is due to the fact that the first six plates are full

length and may therefore be considered as forming a beam of uniform section. The remaining plates, beginning with the seventh, are graduated and may be regarded as forming a beam of uniform strength. The load applied was great enough to give a permanent set to all of the plates, the load carried by each section under such conditions being proportional to the number of plates in that section. The deflection of the first six plates is therefore governed by the laws for a beam of uniform section, while the deflection for the remaining plates is governed by the laws for a beam of uniform strength, the deflection in the latter case being 50 per cent greater than that for the former.

From the foregoing consideration it may be generally concluded that variations in the fitting of the plates in springs similar in other respects will have little influence upon their flexibility in service. Even though the shop test is omitted the overloads received in service soon tend to eliminate any variations due to the method of fitting the plates.

[EDITOR'S NOTE.—The remainder of Part II will be published in an early issue.]

FORGED AND ROLLED STEEL PISTONS*

BY W. W. SCOTT, JR.†

So far as balance is concerned, the modern electric locomotive is almost perfect for there are no reciprocating parts to be partly or fully balanced. Hence the drawbar pull is practically constant, the weight on drivers is constant, there is no hammer blow on the rail and the locomotive is capable of much greater speed with safety than the most perfect reciprocating steam locomotive.

It is necessary, of course, to balance the reciprocating parts of a steam locomotive so that the engine will not buck or plunge and will have a fairly constant draw bar pull, but in the light of present-day knowledge, the old idea of using heavy reciprocating parts simply because they are strong and cheap, seems like putting the cart before the horse. It is evident without argument that the maximum weight on drivers should be figured for a higher speed than the locomotive makes on ordinary runs, because the static driver load in steam locomotives, unlike that in electric locomotives, is no indication whatever of the blow transmitted to the rail at speed, and has little to do with the effect on track, unless the static load is excessively high and causes a crushing of the rails due to rotating effect. The important fact is that the overbalance in the driver hammers the rail when the locomotive is in motion. The greater proportion of broken rails occur during freezing temperatures. Many of them are diagnosed as "crystallized." Let it be here stated that rails do not crystallize: such rails are broken by the centrifugal force of the overbalance coming at a time when the track is frozen rigid and cannot cushion the shock. To reduce the overbalance blow is to reduce the number of broken rails.

Would it not be wise to rule that no locomotive (let us say passenger at 70 m. p. h.; freight at 45 m. p. h.) shall have an impact on rail due to overbalance of more than 30 per cent of the static weight on the drivers? This is much better than the ordinary American practice, although it is strictly followed by the Pennsylvania Lines East of Pittsburgh whose maximum weight on one driving wheel is 32,500 lb. No engine is allowed to show more than 30 per cent dynamic augment (at the speed mentioned) or 9,750 lb. per wheel. That such a rule is not a hardship is proved by the fact that some of the German railways allow only 15 per cent dynamic augment at high speeds. When one considers the fact that in this country the average is about 62½ per cent, it is high time that it be reduced. A rule making necessary the reduction of reciprocating weights may, at first thought, seem to be a hardship, but a little reflection will show

*From a paper presented before the Railway Club of Pittsburgh, November 27, 1914.

†Carnegie Steel Company.

that to do otherwise, even though it adds a trifle to the first cost of the locomotive, is to be "penny wise and pound foolish." Let it be stated here, however, that a rolled and forged steel piston will not increase the cost of a locomotive. The value of all the reciprocating parts in all locomotives in this country probably does not exceed 1 per cent of the value of the rails in track, and it is positive economy to save the greater investment in rails by lightening the weights of reciprocating parts which represent the smaller investment.

A new method of manufacturing pistons has been developed by means of which a saving in weight of 10 to 50 per cent or possibly more for certain types, can be accomplished. The process has been worked out by the Carnegie Steel Company at its Homestead car wheel plant where, among other circular sections, pistons are made practically complete from the ore to the finished product.

The ingots are cast according to usual open hearth furnace practice in moulds 22 in. by 22 in. and about 6 to 7 ft. long. After stripping and soaking in the furnaces at the blooming mills in the customary way, the ingots are rolled into round blooms 15

while the center, naturally the weakest part, eventually becomes the core and goes back into scrap. It is, of course, understood that sufficient discard has been made from the rolled round bloom to insure freedom from piping.

The discs when cold are carefully inspected for surface or rolling defects and any present are either chipped out cleanly by means of pneumatic chippers, or the disc is scrapped. From the inspection yards the discs are taken to the wheel plants and in the case of pistons and other sections lighter than car wheels are heated in a continuous gravity furnace insuring the rolling of each disc in its proper order at a uniform heat.

By means of a dog running between two rails, each disc is transferred to a hydraulic press the function of which is to pierce a hole considerably smaller than the rough bore desired about half way through the center on the axis of the disc in order that it can be held between the rolls on a pin, until the hydraulic pressure applied grips it and forging commences. The mills were designed and patented by E. E. Slick and are unique in that they are the first of their kind ever built and are original in every respect. Each mill, of which there are two, is

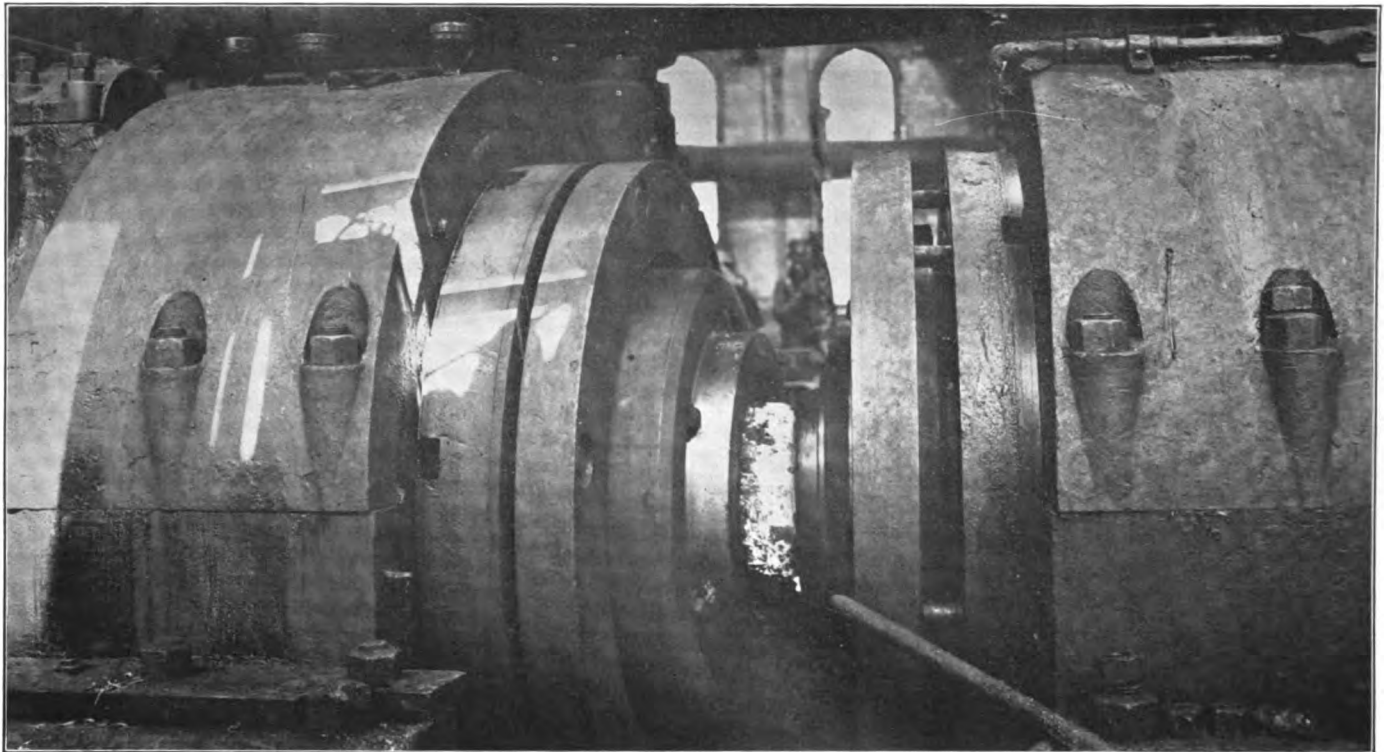

Forging and Rolling Mill in Which Pistons Are Formed

in. in diameter and, while hot, sheared into discs or "cheeses" of the proper weight to produce the required section by further forging and rolling. Attention is called to the forging and rolling work done on the steel through the reduction of a 22 in. by 22 in. ingot into a 15 in. round in the blooming mill. This reduction represents a very important refinement of the rough cast ingot into a forged product of uniform and sound structure, which is far superior in its adaptability for the final forging operations than a raw casting of steel.

The question may arise as to why these blocks are sheared from rolled rounds into the form of discs rather than from flat slabs into the form of squares, as made for annular sections at Homestead and other plants some years ago.

The answer is the keystone of the present-day success of rolled steel sections such as passenger, tender and freight wheels, and lies in the fact that the outside of the ingot which, according to the nature of the elements composing it, is its best part, finally becomes by this process, the outside or periphery of the section

composed of two rolls or dies facing each other, set on the ends of two shafts which are out of line; one mill having the shafts approximately 14 deg. and the other approximately 7 deg. out of parallel. It is evident therefore that when the dies are brought together before the shafts turn, the disc is subject to a forging action. When sufficient forging has taken place under a hydraulic pressure starting at about 700,000 lb. and intensified to 3,000,000 lb. maximum at the finish in the larger mill, to start the piece into the contour of the die, power furnished by a 2,500-hp. steam engine is applied to revolve the roll shaft, and from this point until the piece is taken from the rolls, it is subject to both rolling and forging action, which insures close-grained, well-worked metal.

After rolling, the piece is put through a shear which automatically frees it of the "flash" which is usually present in a flat forging. In the same machine the core previously mentioned is punched out to make the rough bore, thus freeing the steel of any undesirable segregation that may happen to be present after

the discard from the round bloom has been made at the blooming mill shears.

After punching the bore, the piece is rough turned on the periphery, on the edges of the rim and on both faces of the hub in order that any scale or surface defects may be eliminated and clean, sound metal assured.

After passing final inspection, the product is ready for shipment. The method just described refers only to plate pistons.

Solid plate pistons are not new, steel castings in this form having been used as long ago as 1900 in Europe and are now used more or less extensively in this country in low pressure cylinders of compound engines where the diameters are such that the weight of a box or double wall piston would be prohibitive.

It is no doubt true that a steel piston working in a cast iron cylinder will score or cut the latter if they come in contact and with this contingency in mind, almost all American designing engineers bolt or rivet a cast iron bull ring to a steel center, the former being provided with grooves for cast iron piston rings. There have been some noteworthy diversions from this practice, however, particularly on locomotives operated by the Norfolk & Western Railway. One method used by this road is to pour molten iron into a groove machined in the face of the piston. Another is to pour in molten bronze in the same manner, afterwards turning in a lathe to the proper diameter. Both of these

tion, and it is the part of discretion to prepare for the contingency that when the engine is drifting long distances, the cylinders may not be properly lubricated.

If, then, there may be times under certain conditions when the cylinder is comparatively dry with the piston riding on the cylinder, it is certainly better practice to have an anti-friction metal in contact with the cylinder rather than even the best of cast iron, so that wear will be reduced to a minimum and scoring eliminated. For this reason it is recommended that solid steel pistons (unless supported by an extended rod) be faced with a bearing metal that will not only stand a temperature of 618 deg. F., but will also be malleable enough to permit of hammering in segments into dovetail grooves. We have made laboratory tests of a new bull ring metal which showed an extending point of 1,150 deg. F., an average scleroscope hardness of 8, and which can be easily peened into a dovetailed groove $\frac{1}{4}$ in. to $\frac{3}{8}$ in. deep. This is not an experiment, for pistons as large as 50 in. in diameter, faced with bearing metal, are in use in many heavy duty rolling mill engines. Such a piston weighing 3,400 lb. may be found in operation at the Homestead steel works.

Time and test will prove whether the bearing metal mentioned will stand the ravages of superheated steam, but it is safe to assume that if it will not do, another bearing metal can be developed which will be satisfactory. We have known for many years that the proper kind of bearing metal will reduce friction,

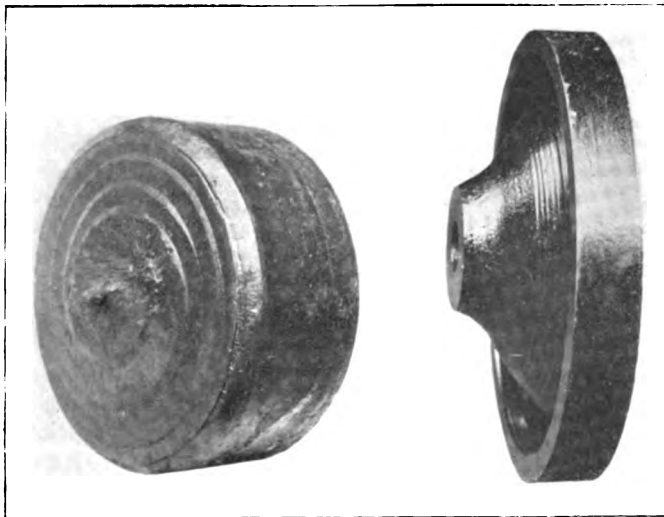

Disc Sheared from Round Bloom; and Finished Piston

types are said to operate efficiently, but it is not the easiest task in the shop to replace the worn-down bearing surface, as the shrinkage of metals must be well understood by the workmen in order to get a tight fit. It is suggested here that the practice of designers of heavy stationary engines be followed in using solid rolled steel pistons in locomotives. That is to cut one or more dovetailed grooves in the face of the piston, insert segments of good malleable bearing metal and hammer it solidly into the grooves. It has been found that bearing metal in the face of the piston polishes the cylinder walls, thus facilitating lubrication.

The solid steel pistons for the Pennsylvania Railroad are used with extended rods which have the advantage of reducing cylinder wear and simplifying lubrication. The extended rods in use some years ago, which were discarded, are not to be compared with those in use on the latest types of engines, for the old rods and pistons were much too heavy, the pressure on front bearings being as high as 50 lb. per sq. in., while the new type of extended rod has a pressure on the front bearing of only 10 lb. per sq. in. The old types of extended rods were of no particular value in saturated steam locomotives where good cylinder lubrication was comparatively easy to obtain. With superheated steam, however, a very different condition prevails as to cylinder lubrica-

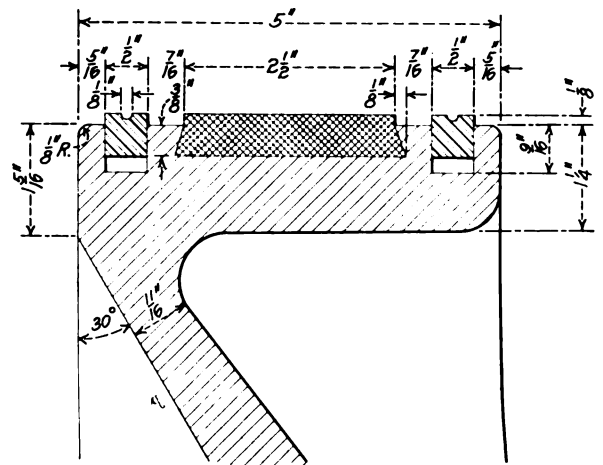

Forged and Rolled Steel Piston Faced with Bearing Metal

and losses by friction in locomotive cylinders are more than a mere trifle.

It has been suggested that rolled and forged pistons be faced with a cast iron ring like piston rings except wider, set in a groove $\frac{1}{8}$ in. less in depth than the thickness of the ring; the ring to be halved, or in three segments, and when assembled in the piston, to be slightly less in diameter than the cylinder. This scheme should work whether the bearing rings are fastened to the piston or simply held in place by the cylinder walls. It has a distinct advantage in the ease of replacement of the bearing face, as well as being economical.

Many ways can be worked out by which a forged and rolled steel center can be attached to cast iron bull rings, but if cylinder bushings or cylinders are to be protected against excessive wear, an anti-friction face is the logical progression. It is, of course, impossible to roll any kind other than one having a single plate. It is possible to roll centers that are intended to carry a cast iron bull ring, but the tendency of the times is to reduce the number of parts as well as the weight, and therefore the solid forged and rolled steel piston takes its place as the latest development in this line.

CRUDE OIL.—California's crude oil production in 1914 was 103,623,695 barrels, as compared with 97,867,147 barrels in 1913. —Power.

PERFORMANCE OF LOCOMOTIVE FIREMEN

W. J. Tollerton, general mechanical superintendent of the Rock Island Lines, in his testimony before the board of arbitration hearing the engineers' and firemen's demands for increased wages in the western territory, presented some very interesting testimony on the work performed by the firemen on different sizes of engines. He presented as an exhibit a summary of 1,556 tests of runs made in regular passenger and freight service on various roads, which showed that out of an average of 8 hr. 47 min. in total time on duty, the fireman was supplying coal to the firebox 1 hr. 42 min., or 19 per cent of the time. He was actually engaged in manual labor 2 hr. 42 min., or 31 per cent of the time, and for 6 hr. 5 min., or 69 per cent of the time, he was performing no physical labor. During these runs 8.67 tons of coal were used on an average per trip, which makes the average pounds of coal fired per hour during the whole time on duty 1,975 pounds. The total time on duty was computed from the time of departure to the time of relief from duty, and where it was the practice to allow preparatory or relief time, this was included. The times obtained for the actual supplying of coal to the firebox were taken by practical locomotive men on the roads making the tests by means of the stop-watch. This time includes not only the time actually spent in shoveling the coal into the firebox, but also the time consumed in

gangway at ease. In the majority of cases, the coal used was obtained by counting the number of scoops of coal supplied to the firebox during the individual trip.

Mr. Tollerton also presented information from 474 trips made in freight service alone on locomotives weighing 185,000 lb. and over on drivers. The firemen on these test trips were on duty for an average of 9 hr. 39 min. They were supplying coal to the firebox 2 hr. 12 min., or 23 per cent of the time, and they were engaged in manual labor 3 hr. 14 min., or 33.5 per cent of the time, leaving 6 hr. 25 min., or 66.5 per cent of the time in performing no labor. The average amount of coal used per trip in this set of tests was 12 tons, making an average of 2,460 lb. per hour for the total time on duty. The information obtained from these tests was further subdivided between saturated and superheated steam engines for locomotives weighing from 185,000 lb. to 200,000 lb. on drivers; 200,000 to 225,000 lb. on drivers; 225,000 to 250,000 lb. on drivers and 300,000 lb. and over on drivers. The accompanying diagram illustrates the percentages of time the fireman was occupied in shoveling coal into the firebox, in performing manual labor, and in performing no physical labor, for the different classifications of the locomotive mentioned above. The curves at the top of the diagram show the average amount of coal fired per hour in pounds for the two classes of engines on a basis of the weight on drivers.

These diagrams show in an interesting manner the advantages to be derived from superheated locomotives and show conclusively that with the increase in the size of locomotives the rate of firing has increased very little. It is interesting to note also that the time the firemen spent in manual labor on heavy superheated steam engines does not amount to the corresponding time for even the lightest saturated steam engines shown. The results of these tests show how locomotive designers have, with the increased size in locomotives, considered the work of the fireman by providing labor-saving devices, such as superheaters, stokers, automatic firedoors, grate shakers and the like.

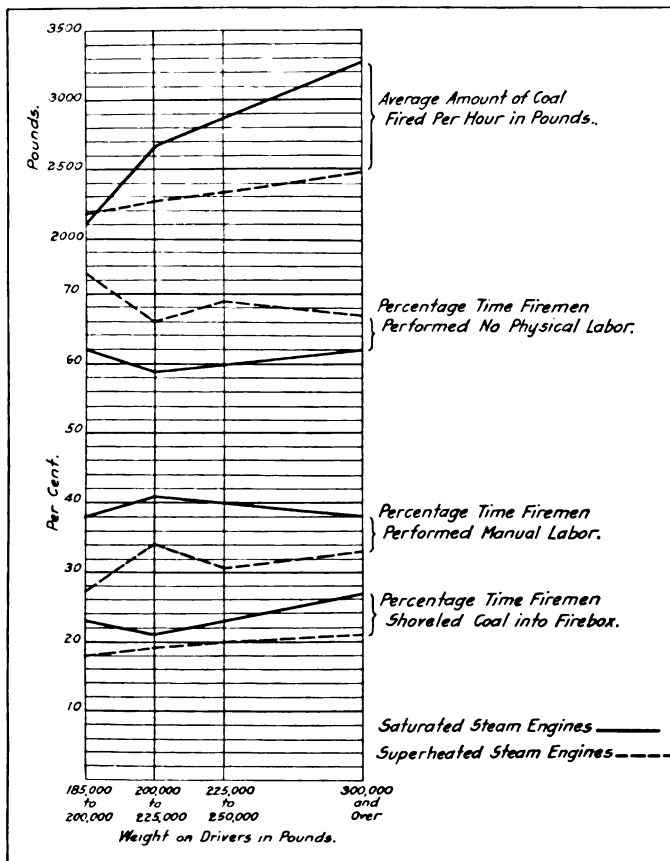

Diagram Illustrating the Performance of Locomotive Firemen

leaving and returning to the seatbox or the gangway. In the same manner the time engaged in manual labor was obtained. This includes, in addition to supplying coal to the firebox, the sweeping of the deck, shaking the grates, taking coal and water, etc. The balance of the time, 6 hr. 5 min., or 69 per cent of the total time on duty, represents the time the fireman was either sitting on the seatbox or standing in the

TECHNICAL HIGH SCHOOL IN MILWAUKEE.—A plan for the establishment of an exclusively technical high school as part of the city of Milwaukee's educational system has been completed by Milton C. Potter, superintendent of schools, and Charles F. Perry, supervisor of industrial education. The board of school directors has taken steps looking to the immediate establishment of the institution. The academic work is to consist of a course in English, sciences and mathematics. Practical work is to be done in Milwaukee shops and factories.—*Iron Age*.

UNITED STATES NAVY SPECIFICATIONS.—The new specifications of the United States Navy indicate a changed opinion as to the extent to which sulphur is detrimental in steel castings. Former specifications allowed a maximum of 0.05 per cent sulphur in all carbon castings of grades A B and C and 0.04 per cent in nickel-steel castings designated as "special grade." In the new specifications grades A and B are subdivided into two classes—A and D, the high carbon, and B and E, the medium carbon respectively. A and B maintain the old limit of 0.05 per cent sulphur and D and E permit castings to go as high as 0.07 per cent sulphur. The two subclasses include castings of less importance than the others. For castings in grade C the limit is changed from 0.05 per cent sulphur to 0.07 per cent. The nickel-steel or special grade castings now have 0.05 per cent instead of 0.04 per cent sulphur as the limit. The requirements for tensile strength are reduced from a minimum of 90,000 lb. per sq. in. in nickel-steel to 85,000 lb. The elastic-limit stipulation is 45 per cent of the tensile strength in carbon castings, instead of a definite limit in pounds. The elongation requirements are advanced from 20 to 22 per cent in the special, or nickel-steel, grade, and the bending bar required is 120 deg. instead of 90 deg.—*American Machinist*.

CAR DEPARTMENT

FREIGHT CAR REPAIRS UNDER A PIECE WORK SYSTEM*

BY J. J. TOLIN

Foreman Car Repairers, Pennsylvania Railroad, Buffalo, N. Y.

Inspection of and repairs to freight cars on a shop repair track should be divided into three classes:

First—Light repairs to all classes, which should include the renewal of wheels, couplers, draft timbers, arch bars, and all repairs of a minor nature.

Second—Heavy repairs to all classes of wood or composite cars, which should include renewal or splicing of sills, renewal of roofs, or the complete rebuilding of the car body when necessary.

Third—Heavy repairs to all classes of steel cars, which should include the renewal or splicing of sills, renewal or patching of sheets, or the cutting down and rebuilding of the entire car when necessary.

Each of these classes should then be sub-divided into two classes: the air brake apparatus and its connections; and the other parts of the car. There should also be two sets of piece work inspectors and repairmen, one to act as specialists on the air brake apparatus and the other on the other parts of the car.

When a car requiring light repairs arrives on the repair track, the piece work inspector supervising repairs to parts other than the air brake should make a thorough examination of the wheels, journal boxes and their contained parts, arch bars, brake beams, and all parts below the body of the car. At the same time he should note the condition of the draft timbers, couplers, end sills, and all parts that are visible from the ground. He should then make the roof inspection, paying particular attention to the brake wheel, ratchet wheel and pawl, to see that the hand brake can be operated, and that the brake pawl will properly engage the teeth of the ratchet wheel. The deck hand-holds and running board also demand preferred attention since they are essential parts.

Next the interior of the car should be inspected, assuming that it is an empty house car, and repairs should be made according to the class of freight which the car is to carry. The authorized piece work card should then be prepared, enumerating thereon all defects which in the judgment of the piece work inspector should be repaired, and he should bear in mind that only such repairs as are necessary to make the car safe for trainmen and for lading suitable to it should be made to a foreign car. While making repairs, the repairman should be guided by the piece work card and should not be permitted to repair any defect that had been overlooked by the piece work inspector and discovered by him without first calling it to the attention of the piece work inspector and having it added to the work card if the inspector decides that the defect should be repaired.

The air brake piece work inspector should make a thorough inspection of the hose, hose couplings, pipe hangers, pipe supports, cylinder and reservoir and their blocks, to see that they are in good condition and firmly secured to the car. He should then fill out the authorized piece work form, noting thereon any defect that he may have discovered.

The car is now ready for the air brake repairman. He should first read the piece work card and then proceed to make the repairs enumerated thereon. When this has been done he should attach the yard air line to the air hose at one end of the car and a dummy coupling to the hose at the other end and open the valve from the yard air line. While the system is charging he

should disconnect the retaining pipe from the triple valve and in the exhaust port of the triple place a nipple with an air gage attached to it. He should then take a pail of thin soap suds and with the aid of a suitable brush completely cover the air hose and all joints on the brake and crossover pipe. If a leak in either of these pipes is discovered the piece work inspector should be called and decide whether or not it is of enough importance to repair.

When the system is charged and the brakes are applied by making a 25 lb. reduction in brake pipe pressure, the length of the piston travel should be noted and the brake released by turning the air into the brake pipe through the 1/16 in. opening in the disk located in the 1/4 in. pipe on the testing device. The gage which is attached to the exhaust port of the triple should be carefully watched for one minute and if it shows a leakage in excess of five pounds the defect causing the leak should be located and repaired. After the defect has been repaired a like test should be made to insure that the leak has been reduced below five pounds per minute.

The retaining pipe should be connected to the triple valve and slack adjusted if necessary, paying particular attention to the equalization of the brakes, and with the retaining valve handle at right angle on a two position valve or at 45 deg. on a three position valve, the brakes should again be applied and released. All joints on the retaining pipe should then be covered with soap suds and all leaks repaired, no matter how trifling they may be, for the reason that the retaining pipe must be absolutely tight, otherwise it is useless. The repairman should then wait until the air ceases to escape from the exhaust port in the retaining valve and then turn down the handle. If a gush of air escapes at this time the retainer is in good condition. If air escapes at a very low pressure or no air escapes the retainer is defective and should be repaired or replaced with a new or repaired valve. Under ordinary circumstances the brakes could now be depended upon as being in good condition.

HEAVY REPAIRS TO ALL WOOD OR COMPOSITE CARS

A wood or composite car requiring heavy repairs should be jacked up, placed on trestles and the trucks removed before inspection is made. The inspector should first thoroughly inspect the longitudinal sills, end sills, cross bearers, draft timbers, etc. Taking, for illustration, a box car, he should determine whether or not the general condition of the car would warrant putting it in condition to carry first class freight. If he decides that it should be made fit for this purpose he should inspect the siding, lining, flooring and grain strips, condemning any of these parts that are not in perfect condition. The roof should then be thoroughly examined for evidence of leaks and if any are found the cause must be remedied.

All parts of the trucks should now be examined and the piece-work form prepared, which should show all repairs necessary, except to the air brake apparatus.

While the car is undergoing repairs the work should be closely checked by the piece work inspector to see that both lumber and bolts of proper dimensions are used; that the lumber is properly framed, and that holes bored by the repairmen are not more than 1/16 in. larger than the diameter of the bolts or rods that are to be placed in them. The piece work inspector should also see that all parts are applied as shown on the standard drawing, that is, the sizes of tenons, mortices, etc., not changed by the repairmen to make the part simpler to apply.

The air brake attention in this case is much the same as in that of the car requiring light repairs with the exception of removing and replacing the apparatus, including pipe where it

*From a paper read before the Niagara Frontier Car Men's Association, Buffalo, N. Y., June 16, 1915.

interferes with the renewal of longitudinal sills. It is also important in this case that pipe be thoroughly blown out before it is connected to the triple valve. The brake apparatus must be cared for while it is off the car by closing the opening in the triple valve check case and exhaust port with wooden plugs to prevent dust from entering the triple.

HEAVY REPAIRS TO STEEL CARS

The all-steel car does not ordinarily require heavy repairs as frequently as the car of wood construction, but when it does require this class of repairs they are usually more extensive; consequently the number of days out of service per year is approximately the same as that of the wooden car.

The time out of service can be reduced, however, by increasing the number of men working on the car, and in order to do this and still maintain a high degree of efficiency the men must specialize on some particular kind of work; for instance, cutting off rivets, heating rivets, driving rivets, etc.

My slight experience in the steel car field has taught me that as many as fifteen repairmen can be successfully worked on one car, as follows: Cutting off and backing out rivets, four; repairing bent parts off car, bolting them up in place for the riveters and straightening parts on car, four; reaming and drilling holes, two; heating rivets, one; driving rivets, two; removing and replacing parts that are secured with bolts and repairing trucks, two. It is, of course, understood that for this arrangement to be practical there must be several cars on the repair track at one time.

Like the wooden car the steel car should be jacked up, placed on suitable trestles and the trucks removed. All parts that have been affected by corrosion should have the scale removed. The car should then be carefully gone over by the piece-work inspector, he to decide what repairs are to be made and at the same time see to it that no part or parts are removed from the car for repairs that can be successfully repaired in place by using a portable oil heater. He must also exercise good judgment in condemning sheets to be scrapped, particularly in the floors, where it is practicable that floor sheets should be patched until an entire new floor is to be applied. When a floor is to be renewed and one or more sheets are found in fairly good condition, they should also be removed and replaced with new sheets and the sheets that are in fairly good condition placed in stock for repairs to floors that are not yet at a point where the entire floor requires renewal.

The splicing of steel longitudinal sills while in place is very economical. For illustration, in the case of a steel car that has been in an accident and has the longitudinal sills so badly buckled at one or both ends that they cannot be straightened while in place, the sills should not be removed for repairs, but the damaged ends should be sawed off, repaired and spliced to the sills. This can be done at a cost much below that of removing the full length sills for repairs, and the result obtained is just as good or better.

The manner in which rivets are driven in steel cars is another important feature. The piece work inspector should inspect each morning all rivets driven by the repairmen on the day previous, and each rivet should be tapped with a light hammer, and any found loose ordered removed. Rivets with heads poorly formed on account of poor heating, or rivets too long or too short should also be ordered removed and only the rivets that pass inspection should be paid for. The number of rivets driven should be checked daily by the piece work inspector for the reason that some of them may become covered with other parts and could not be checked at a later date. The rivets that have been checked can easily be identified if bright red paint is used to mark them as they are counted.

The air brake attention necessary is practically the same as in the case of light repairs, except that care should be exercised to keep the cylinder, triple valve, etc., from coming in contact with excessive heat when straightening parts in place.

FORTY-TWO YEARS AGO

In a talk before the Master Car Builders' Association during the convention held in Boston in June, 1873, Leander Garey of the New York Central presented some statistics as to the number of cars in service at that time. Compared with the two million odd cars, most of them of large capacity, now owned by the railroads of this country they present an interesting view of the growth and changes in conditions of railroad transportation which have taken place during the past 42 years.

The following is quoted from Mr. Garey's remarks:

"The whole number of cars on all steam roads of 4 ft. 8 in. and wider gages in the United States and Canada, at the close of the fiscal year ending with the year 1871, was as follows:

Whole number of 8-wheel cars.....	193,767
Whole number of 4-wheel cars.....	58,355
Total	252,122
Whole number of cars reported for 3 and 3½-ft. gage roads.....	212

There are in the United States and Canada 103 car manufacturing companies. These companies have built during the year ending May 31, 1873, the following number of cars:

PASSENGER CARS			
Palace, sleeping and hotel cars..	134	Baggage and mail cars.....	33
Passenger cars, all classes....	579	Baggage cars	63
Smoking cars	18	United States postal cars.....	3
Baggage and smoking cars.....	15	Total	863
Baggage and express cars.....	18		
OTHER CARS			
Paymaster cars	6	Stock cars	2,415
Caboose cars	78	Eight-wheel ore and coal cars	3,126
Fruit cars	734	Four-wheel ore and coal cars.	3,226
Refrigerator cars	8	Oil tank (60 barrels).....	250
Grain combination	750	Oil tank (64 barrels).....	300
Box or house-cars.....	11,931	Construction cars	162
Platform	5,694	Steam shovels	52
Gondola	6,733	Derrick cars	8
Double-bottom gondola	125	Hard cars	149
Double-deck cars	80	Total	36,765
Hay (box)	75		

[A similar statement was made of the cars built by the railroads. Because of space limitations it is omitted, but the total number was 22,345 standard gage cars and 466 narrow gage cars.—EDITOR.]

Mr. Garey then continued:

"Allowing six months for the time between the close of the fiscal year of 1871 and the first of June, 1872, we will add one-half of the number of cars constructed during the past year to the number officially reported at that time (1871), and we have for number of cars on the first of June, 1872, 281,667. Add to this the number manufactured during the past year, and it gives us for the total number of cars at the present time, 340,787.

"The increase of cars here stated is under the actual number, as a few roads have failed to report.

"These figures indicate that the increase of cars during the past year has been about 25 per cent, and if we add the cars rebuilt, it will make the increase fully that number."

THE IRON CROSS.—The iron cross, the most highly-prized recognition of valor in the German army and navy, is not a casting, but is struck with steel dies in heavy coining presses. After being stamped out, the crosses are taken to the silversmith's, where the soldering is done, a fine silver border added, and the finishing completed. The silver border is polished on electrically-driven polishing and grinding motors.—*The Engineer*.

PRESSURE DROP AND VOLTAGE DROP COMPARED.—Pressure drop in steam lines is comparable with line drop in electric distribution systems, which is known to be energy lost, but the desired terminal voltage is obtained and the drop compensated for by a slight increase of voltage at the source or apparatus designed to use the lower voltage. Feeders or steam lines large enough to cause no drop are not feasible; the amount of drop to be permitted is a variable quantity. The greater radiation loss from excessively large steam lines has no counterpart in the electric-distribution analogy.—*Power*.

STEEL CARS OF THE ARCH ROOF TYPE

Features of Latest Union Pacific Equipment for Various Classes of Passenger Train Service

The Union Pacific has recently added to its equipment a number of all-steel passenger train cars, built by the Pullman Company. These include dining cars, combination baggage-buffet cars, chair cars, coaches, baggage cars and postal cars.

total wheel base of the car being 67 ft. 9½ in. The seating capacity is 28 and the weight of the car ready for service is about 139,000 lb.

The same design of body is used on the coaches and the

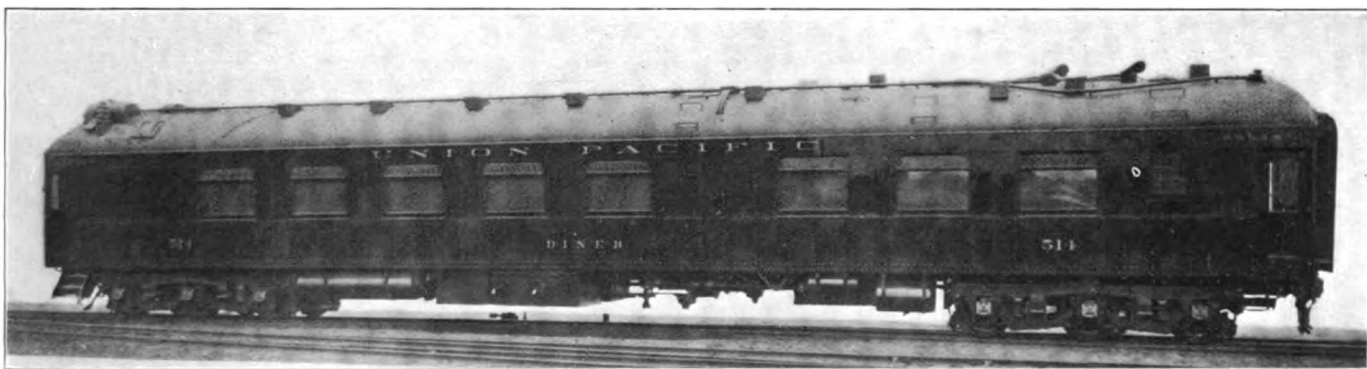

Steel Dining Car in Service on the Union Pacific

The dining cars are 72 ft. 6 in. long over the end sills and 80 ft. 5 in. long over the platforms. The wheel base is 67 ft. 9½ in. and they are mounted on six-wheel trucks. These

chair cars, the length over the end sills being 70 ft., the length over platforms 77 ft. 11 in. and the wheel base 65 ft. 3½ in. These cars are also mounted on six-wheel trucks and

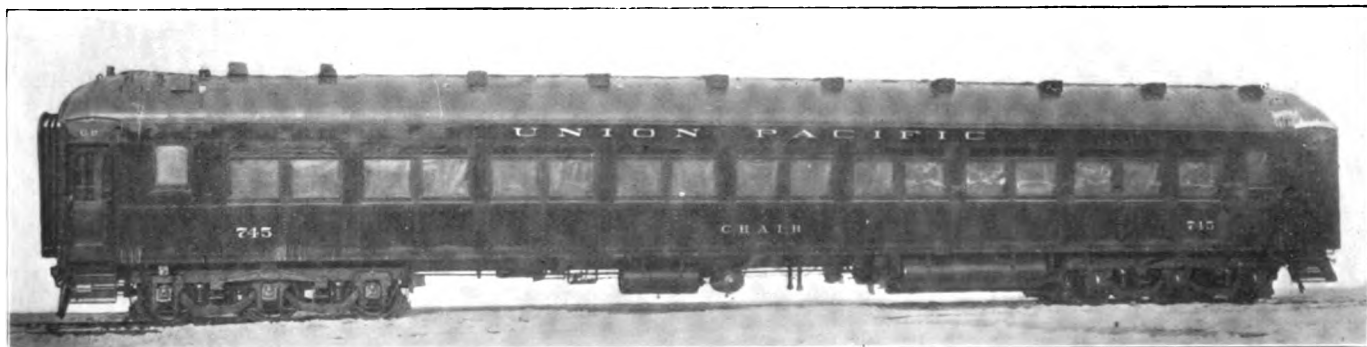

Reclining Chair Car of All-Steel Construction, Used on the Union Pacific

dining cars have a seating capacity of 30 passengers and weigh about 148,000 lb.

The combination baggage and buffet cars are 75 ft. long over the end sills and are mounted on six-wheel trucks, the

weigh about 138,000 lb. Some of them are equipped with a smoking room in one end, in which case the seating capacity of the chair cars is 70, while without the smoking room it is 72; when equipped with a smoking room the coaches have a



Union Pacific All-Steel Postal Car

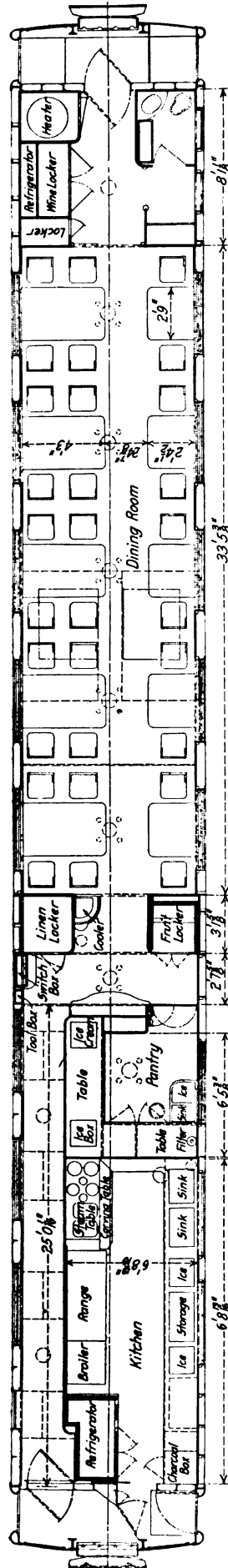

Floor Plan of the Union Pacific Dining Car

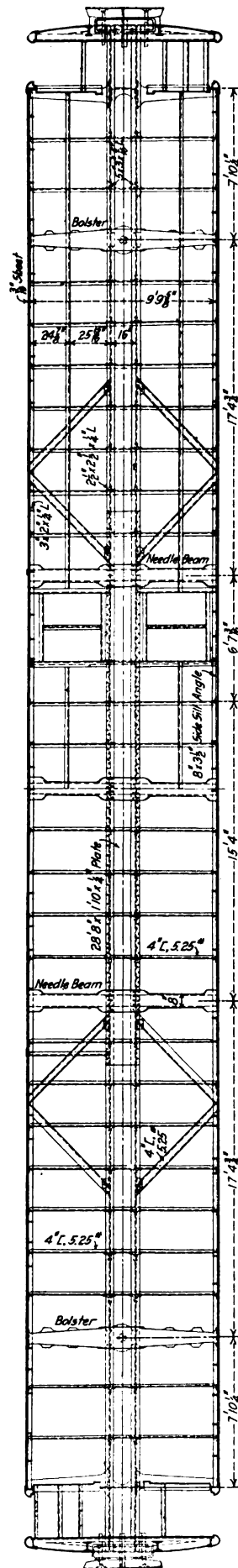

Arrangement of the Underframe of the Union Pacific Dining Car

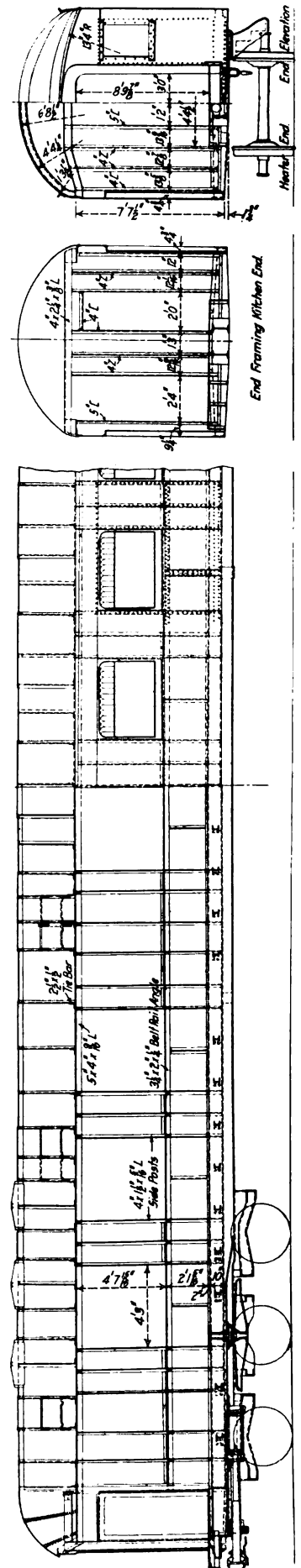

Elevations and Sections Showing the Body Framing, Union Pacific Dining Car

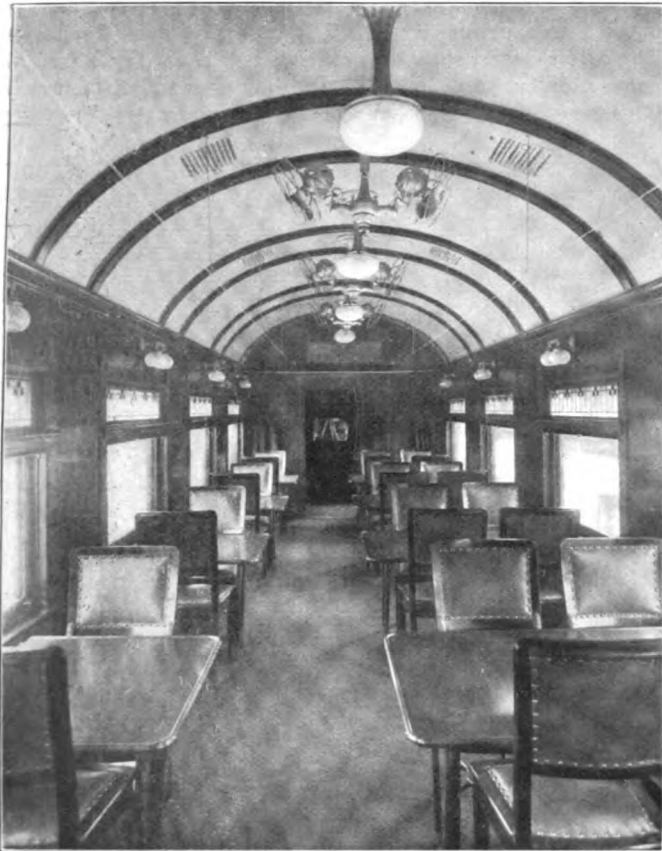

An Interior View of the Dining Car

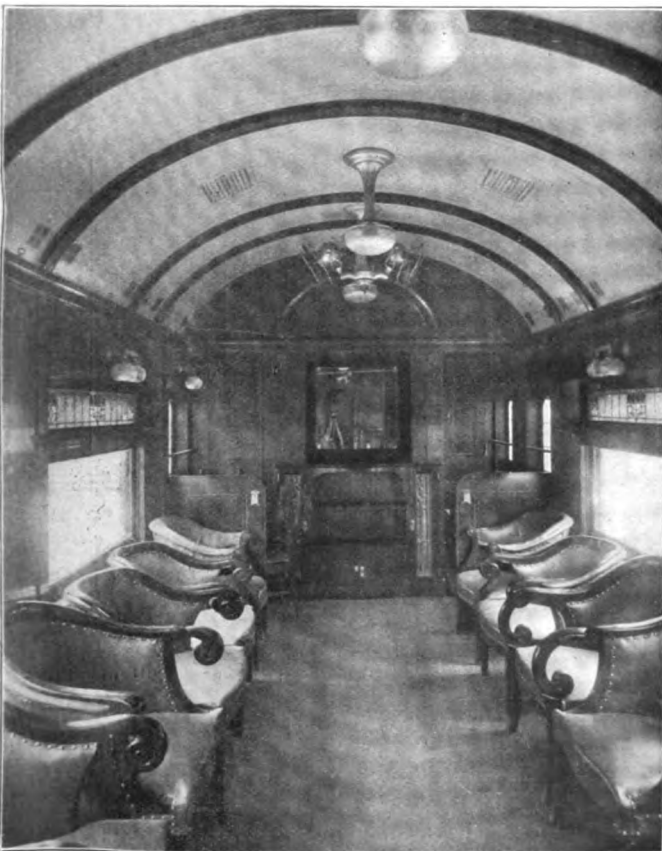

An Interior View of the Baggage-Buffer Car

seating capacity of 82 and this is changed to 84 in the case of a car without a smoking room.

The baggage cars are 69 ft. 0-7/8 in. long over end sills, 71 ft. 11 in. long over the platforms and have a wheel base of 64 ft. 0-7/8 in. They are mounted on four-wheel trucks and weigh about 106,000 lb. The postal cars are 60 ft. 1/2 in. long over end sills and 63 ft. long over the platforms, with a wheel base of 55 ft. 1/2 in. These cars weigh 111,600 lb. There

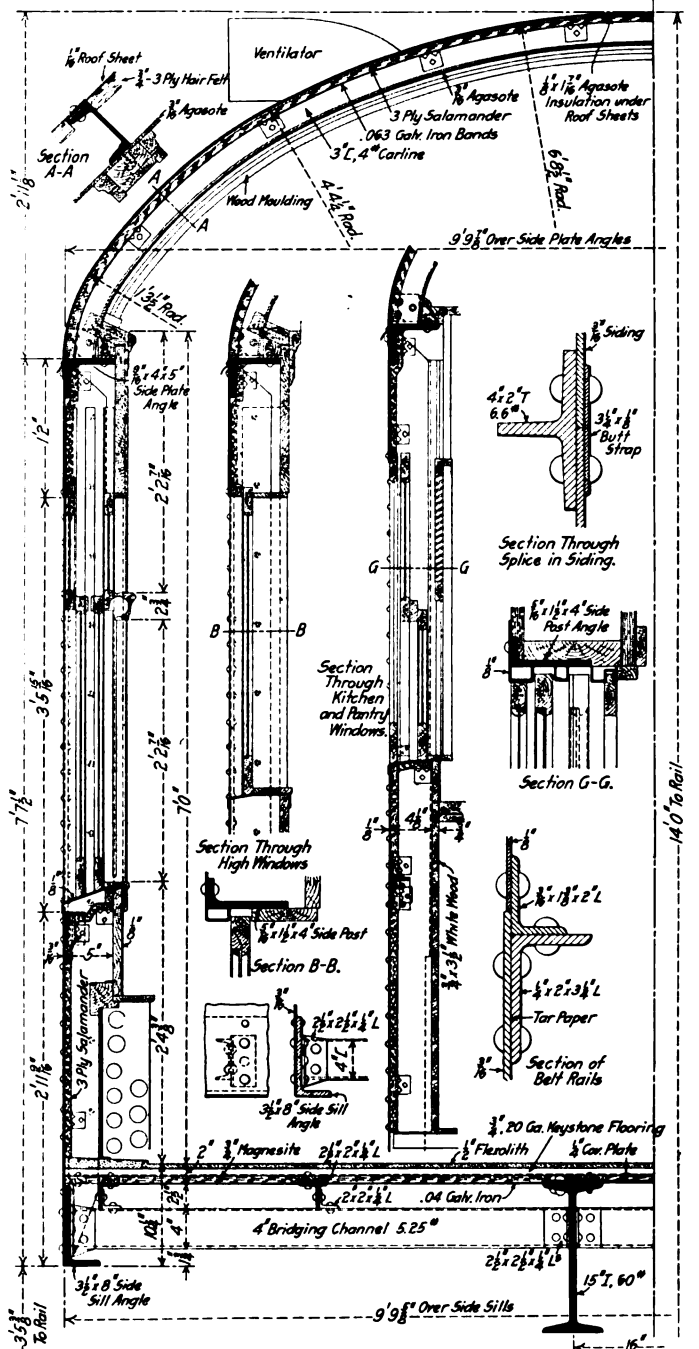

Cross Sections of the Dining Car

are also a number of 60-ft. baggage cars similar to these postal cars. Where six-wheel trucks are used, the design is the same for all the cars and the same is true for the four-wheel trucks.

As will be noted from the illustrations, the type of construction embodies the arch type roof and the arrangement of the framing is similar in all of the cars. Ventilation is

provided by suction type ventilators and has proved to be adequate in all cases.

In the dining car, the center sills consist of two 15-in., 60-lb. I-beams placed at 16-in. centers and extending between the platform end sills. A 22-in. by 1/4-in. top cover plate is used

which is a 1/4-in. by 2-in. by 3/4-in. angle with the 2-in. leg upward, to which is riveted a 3/16-in. by 1 3/8-in. by 2-in. angle. The 3/16-in. steel sheathing extends to a point just above the connection between the two belt rail angles, and 1/8-in. sheathing is used on the car body above this point.

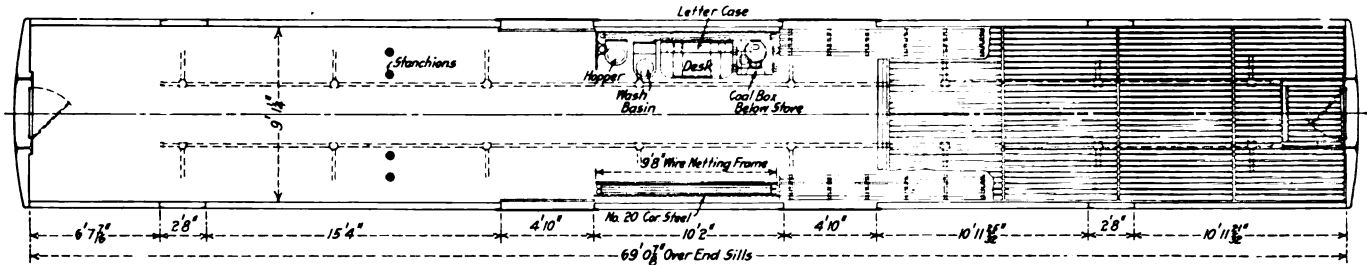

Floor Plan of Steel Baggage Car for the Union Pacific

and the sills are given 3/8-in. camber. The body bolsters are steel castings and there are three crossbearers between the body bolsters. The distance between truck centers is 56 ft. 8 11/16 in. Two sets of diagonal braces consisting of 4-in.,

The body side posts are 4-in. by 1 1/2-in. by 5/16-in. angles and the side plate is a 5-in. by 4-in. by 9/16-in. angle. The carlines are 3-in., 4-lb. channels extending through between the side plates, and the end plate is a 4-in. by 2 1/4-in. by 3/8-in. angle. The body corner posts are 4-in., 5.25-lb. channels and the door posts are 5-in., 6.5-lb. channels, there being two intermediate posts consisting of 4-in., 13.8-lb. Z-bars. The

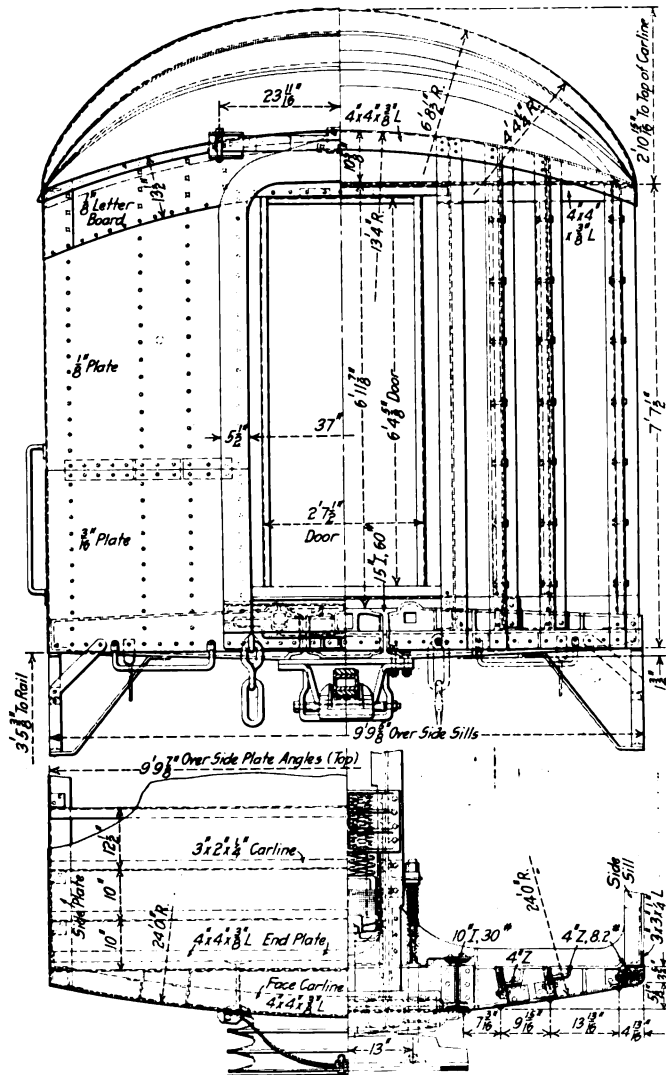

End Construction of Postal and Baggage Car

5.25-lb. channels are employed between the center and side sills and channels of the same size and weight are also used to support the floor stringers, which are 2 1/2-in. by 2-in. by 1/4-in. angles. The side sills are 3 1/2-in. by 8-in. angles, a 3/16-in. plate being riveted to the side sill and to the belt rail,

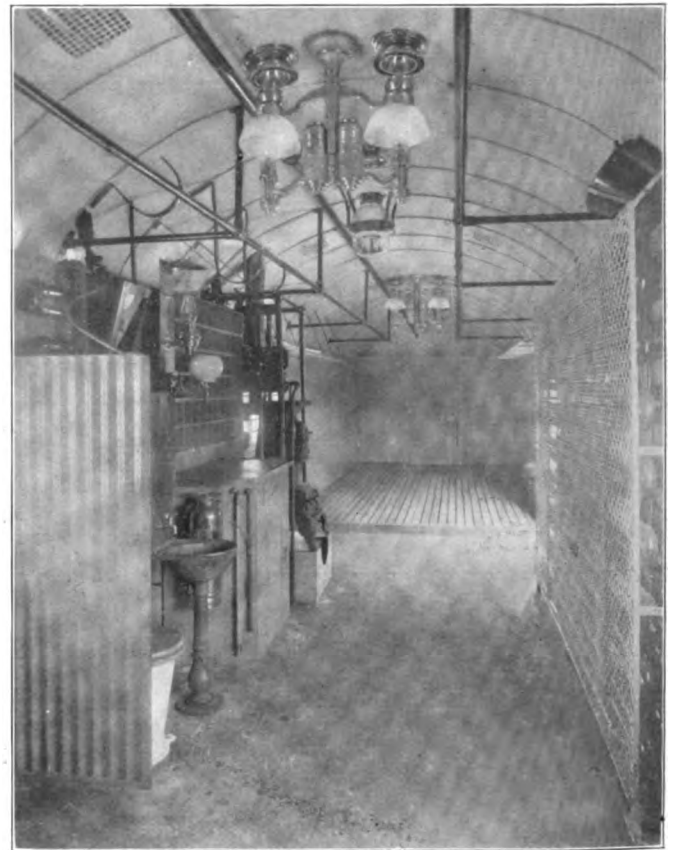

Interior of Union Pacific Steel Baggage Car

vestibule door posts are 6-in., 23.9-lb. I-beams, braced at the top to the body corner posts by 3-in. by 3-in. by 1/4-in. angles, while a 6-in., 8-lb. channel forms the vestibule end plate. The end sheathing of the car body is 1/8 in. thick.

Above the floor stringers is placed .04-in. galvanized iron, above which there is a layer of 3/4-in. Magnesite. Next to this is a layer of 3/4-in., No. 20 gage Keystone flooring, above which is placed the final flooring, which is 1/2-in. Flexolith. Three-ply Salamander insulation is applied to the inside of the steel sheathing, and the windows as well as the interior

finish of the side walls are mahogany; the headlining is 3/16-in. Agasote. The baggage-buffet cars also have mahogany

tudinal floor stringer angles. The belt rail is a 3 1/4-in. by 2-in. by 1/4-in. angle, while the side plate is a 5-in. by 4-in. by 9/16-

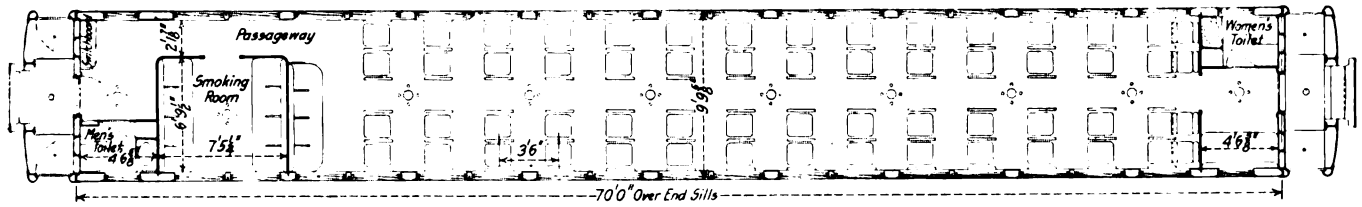

Floor Plan of Union Pacific Chair Car

interior finish, but that of the chair cars and coaches is steel. The I-beam center sill construction is used in all of the

in. angle. The carlines are formed of 3-in., 4-lb. channels. The window sash in these cars are of wood, while the main

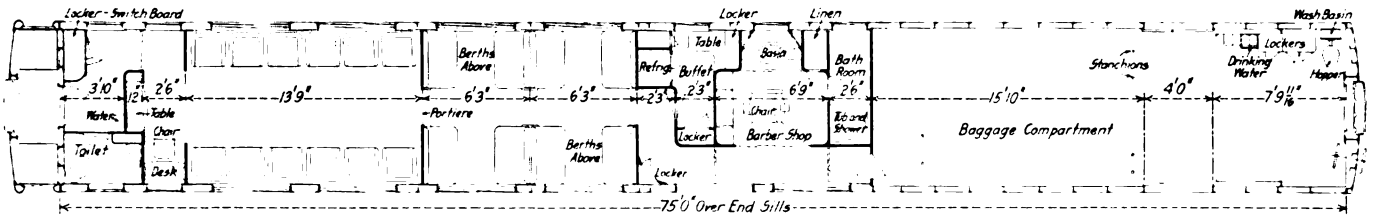

Floor Plan of Union Pacific Baggage-Buffer Car

cars. In the case of the coaches and chair cars these sills are 18-in., 65-lb. I-beams with a 1/4-in. cover plate, while the side sills are 8-in. by 3 1/2-in. angles, the floor being carried by 4-in., 5.25-lb. channels supporting 2-in. by 2 1/2-in. by 1/4-in. longi-

part of the interior finish is of steel and the headlining is 3/16-in. Agasote.

The center sills of the 69-ft. baggage cars are 18-in., 65-lb. I-beams and the side sills are 8-in. by 3 1/2-in. angles. The

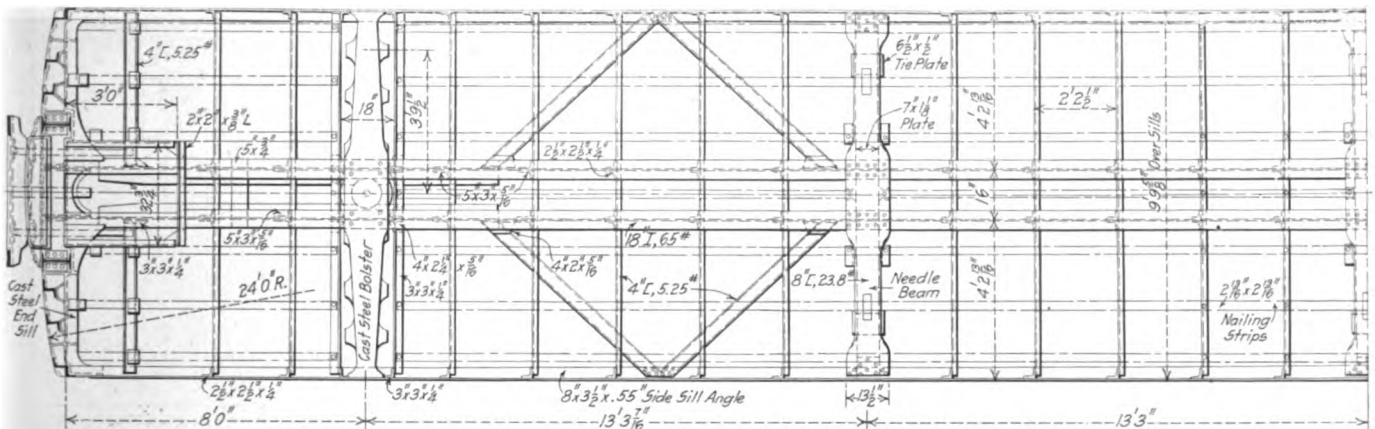

Arrangement of the Frame Members in the Baggage Car

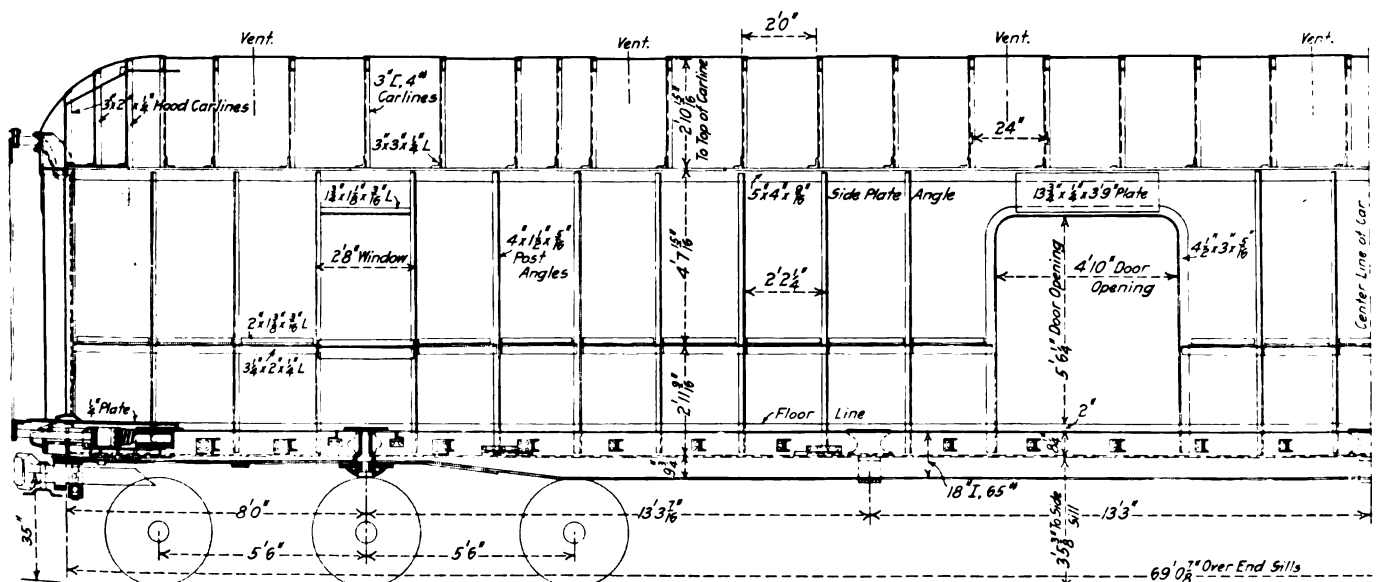

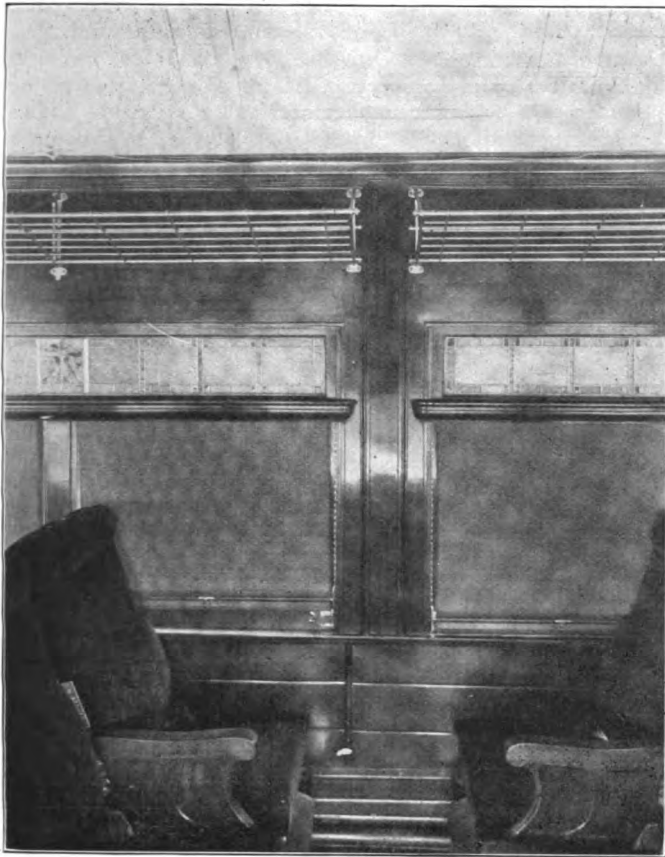

Interior Finish of the Chair Cars and Coaches

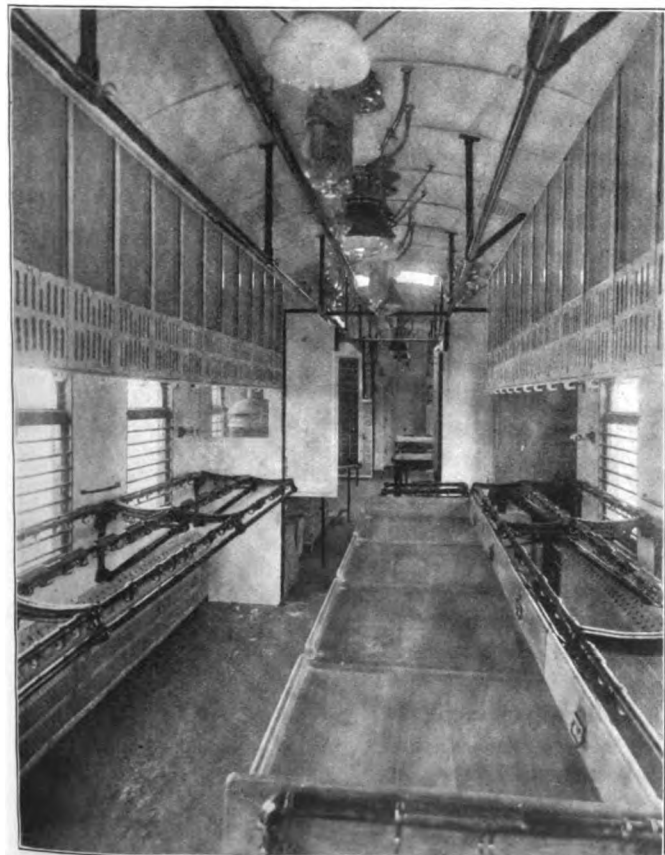

Arrangement of the Interior of the Postal Cars

side plate is formed of a 5-in. by 4-in. by 9/16-in. angle, while the side posts are 4-in. by 1/2-in. by 5/16-in. angles, the belt rails being 3/4-in. by 2-in. by 1/4-in. angles with 2-in. by 1 3/8-in. by 3/16-in. angles riveted to the top. The side door posts are 4 1/2-in. by 3-in. by 5/16-in. angles. The end construction of these cars is of the dummy type, the end sill being a steel casting, while the two center posts are 10-in., 30-lb. I-

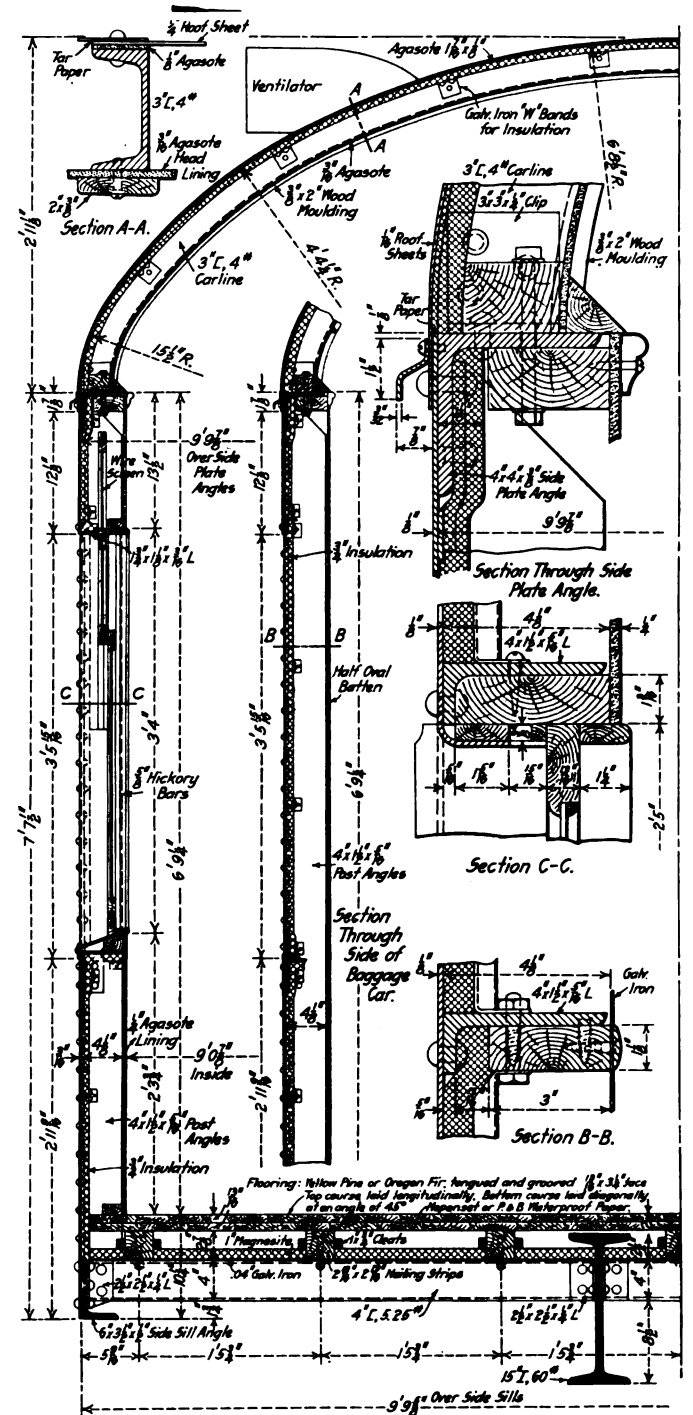

Cross Sections Through 60 Ft. Baggage and Postal Cars

beams. The corner post is built up of a 4-in., 82-lb. Z-bar and a 3-in. by 3-in. by 1/4-in. angle reinforced by wood, and between the corner post and the center post are two 4-in., 82-lb. Z-bar posts. The end of the car is covered with 3/16-in. plate as far as the belt rail, above which 1/2-in. plate is used, while the end carline is a 4-in. by 4-in. by 3/8-in. angle. The end plate of the car is also a 4-in. by 4-in. by 3/8-in. angle.

In the postal cars and the 60-ft. baggage cars the center sills consist of 15-in., 50-lb. I-beams, but no cover plate is employed. The side sill is a 6-in. by 3½-in. by ½-in. angle and 4-in., 5.25-lb. channels are used as supports for longitudinal nailing strips, to which the double board floor is secured.

The special equipment used on these cars includes New York air brakes, Chicago Car Heating Company's vapor system, Commonwealth cast steel truck frames, Creco brake beams, Pitt couplers, Sessions friction draft gear, Waugh-Forsyth buffing device, Acme vestibule diaphragms, Utility ventilators, Transportation Utilities Company's window fixtures, National trap doors, Hale & Kilburn seats, Adams & Westlake's sanitary bubbling water fountains and white metal washstands, Duner flush closets, Johns-Manville Salamander hair felt insulation, Keystone floors, Rausch bag racks in the postal cars, Edison storage batteries and Gould axle lighting generators.

STEEL SUBURBAN CARS FOR THE ERIE

A train of eight suburban passenger cars of all-steel construction, consisting of seven coaches and one combination baggage and smoker, has recently been placed in service by the Erie Railroad. The cars were built by the Pressed Steel Car Company, Pittsburgh, Pa., from designs prepared by L. B. Stillwell, consulting engineer, New York.

The design of these cars was made with a view to meeting the following conditions: Safety and comfort of passengers; low cost of operation; low cost of maintenance, and moderate first cost. In general their construction is similar to that of the New York, Westchester & Boston electric suburban cars, described and illustrated in the May, 1912, issue of the *American Engineer*, page 238, and while they are built for steam operation, provision has been made for the ultimate addition of electric motive power equipment. One of the points of greatest interest in the construction of these cars is

The coaches are 70 ft. 4 in. long over-all and weigh complete 95,400 lb. The table of comparative weights of Erie passenger equipment shown on this page shows that the total weight is less than that of two classes of steel underframe passenger cars having a smaller seating capacity. It shows further that the all-steel car weighs less per seated passenger

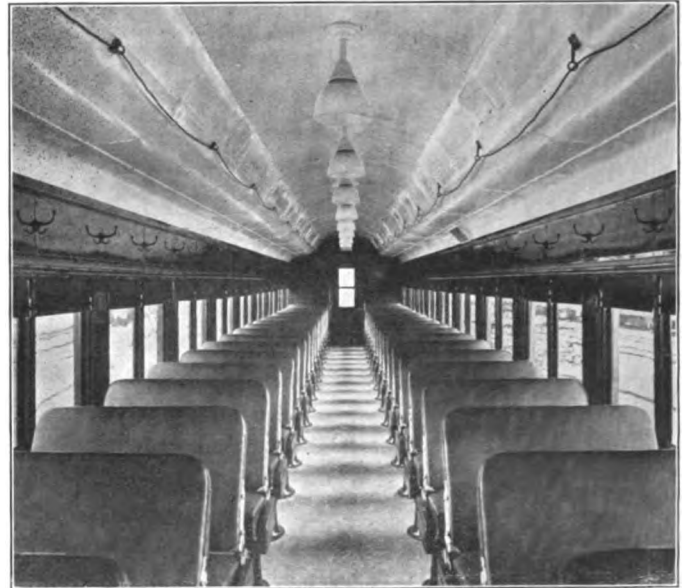

Interior of the Erie Steel Suburban Coach

and closely approximates the weight per foot of over-all length, when compared with the lightest wooden cars in the same company's service.

The comparison per foot of over-all length is unaffected by the seat spacing, and is particularly interesting in this in-

	New cars, all-steel	Class 1935-1950, steel underframe	Class 1910-1934, steel underframe	Class 1825-1874, wood	Class 1800-1824, wood
Number of seats.....	86	72	72	72	72
Average weight, lb.....	95,400	96,500	100,500	83,200	86,600
Weight per seated passenger, lb.....	1,100	1,340	1,400	1,140	1,200
Weight of lighting equipment, lb.....	Battery 8,000	Battery 8,600	Battery 8,000	Gas 2,000	Axle Gen. 6,500
Net weight of car, exclusive of lighting equipment.....	87,400	88,500	92,500	81,200	80,100
Weight per seated passenger, exclusive of lighting equipment.....	1,017	1,230	1,284	1,128	1,112
Length over-all.....	70 ft. 4 in.	66 ft. 3½ in.	66 ft. 3½ in.	66 ft. 3½ in.	66 ft. 3½ in.
Weight per ft. of over-all length, exclusive of lighting equipment.....	1,243	1,333	1,395	1,225	1,210

the arrangement of the superstructure, whereby all parts contribute to its strength to withstand shocks of derailment, overturning or collision. Other notable features are the light weight per seated passenger and the easy-riding qualities which have developed in service.

stance, as the new cars include heavy buffing and friction draft gears, as well as heavy draft sills, whereas the lightest wooden car has only the platforms and wooden draft sills with tandem spring draft gears. The light weight can be attributed to the exclusion of all unnecessary members. The deep and

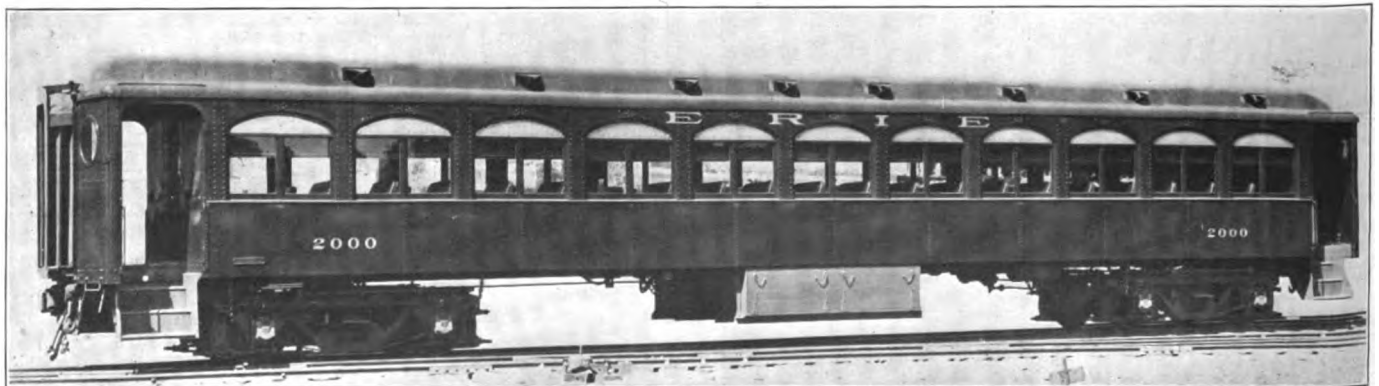

Erie All-Steel Suburban Coach

heavy center sill construction of the fishbelly type has been dispensed with, and sills of uniform section are supported by the deep side frame through a system of crossbearers.

Provisions for application of electric motive power equipment consist in the suitable height and outline of roof to per-

mit of application of overhead current collector if required; the arrangement of vestibule for application of platform control equipment; the arrangement of underframe members for the support of electrical motive power equipment in the most advantageous manner for operation and for thorough inspection and maintenance of apparatus, and the design of draft sills, bolster and trucks to provide clearance for electric motors.

The center sill construction of these cars is of uniform depth and section between bolsters, and consists of two 8-in. 16.25-lb. channels spaced 14 in. back to back, with a 19-in. by

3/8-in. top cover plate and two 4-in. by 3 1/2-in. by 3/8-in. angles reinforcing the bottom flanges. This gives a total section of 22 sq. in. Deep pressed steel draft sills extending through the bolsters reinforce the center sills and at the point of maximum depth add 10 sq. in. to the section.

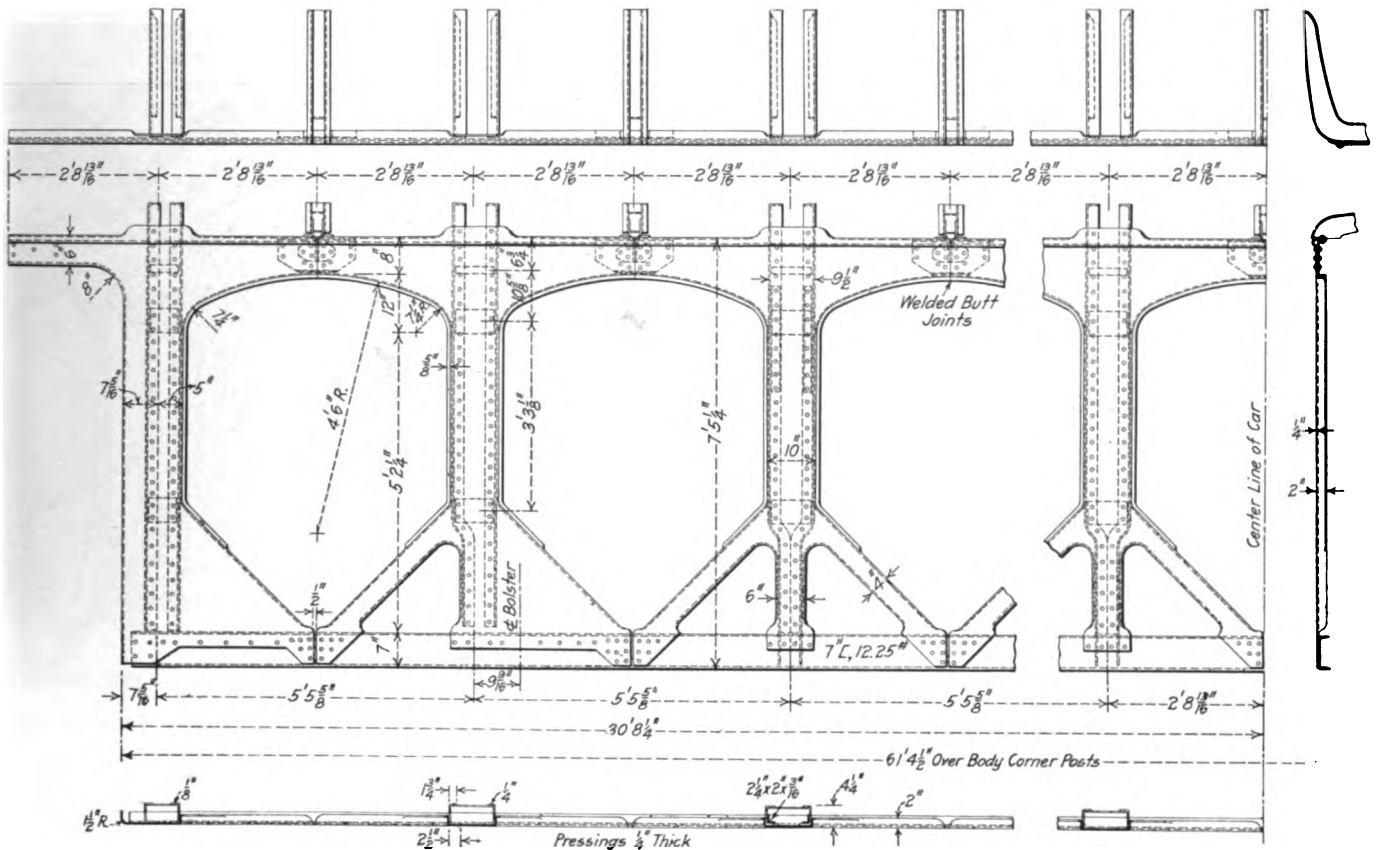

Pressed Steel Unit Side Frame Construction of the Erie Suburban Cars

mit of application of overhead current collector if required; the arrangement of vestibule for application of platform control equipment; the arrangement of underframe members for the support of electrical motive power equipment in the most advantageous manner for operation and for thorough inspection

The center sill construction forward of the bolsters is supported by the high side frames through the body end sill and bulkhead construction. The bending moment occurring at this point due to the eccentric draft gear forces is resisted by the draft sills and is transferred by the body end sill and bulk-

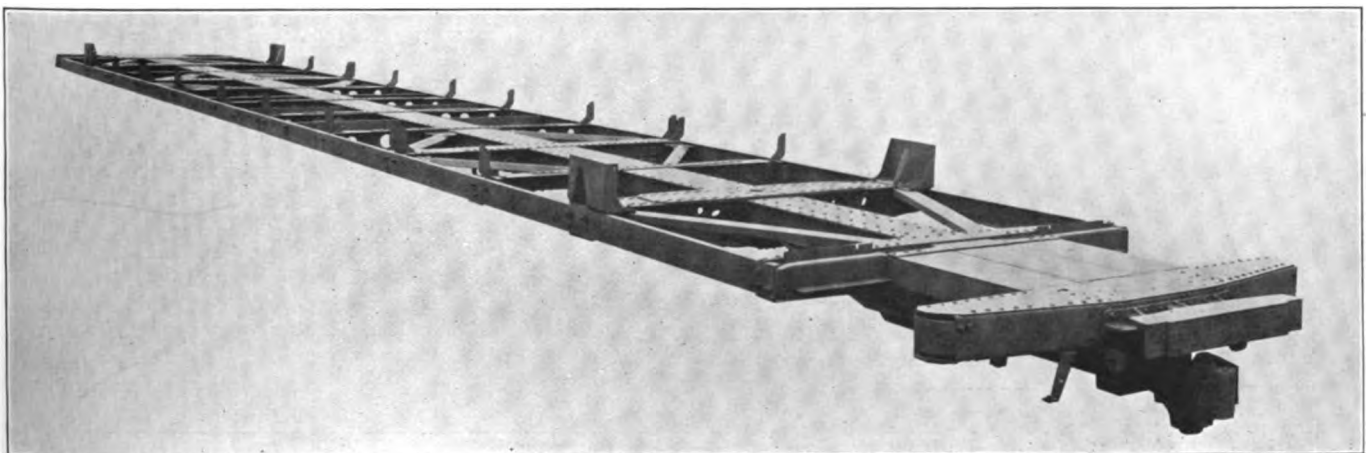

Underframe; Erie All-Steel Suburban Cars

tion and maintenance of apparatus, and the design of draft sills, bolster and trucks to provide clearance for electric motors.

The center sill construction of these cars is of uniform depth and section between bolsters, and consists of two 8-in. 16.25-lb. channels spaced 14 in. back to back, with a 19-in. by

head construction to the high side frames. The center sill construction between bolsters is thus relieved of any eccentric loading from the draft gear forces, and the full section is available to resist the consequent direct compression because of the support which is afforded by the high side

frames and heavy crossbearers placed under the side posts.

The side frames of the car are 7 ft. 5¼ in. from bottom of sill to top of side plate, and are 61 ft. 4½ in. long over body corner posts. The entire frame is designed as a girder, with a pressed steel compression member at the side plate and a 7-in. 12.25-lb. channel tension member at the side sill. The

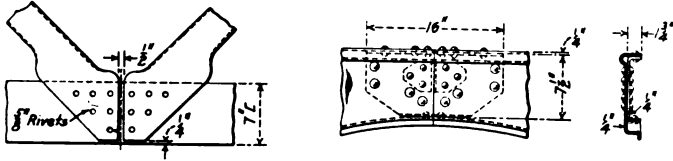

Details Showing Diagonal Brace Connection to Side Sill and Side Plate Splice

posts connecting these members are of 10-in. pressed channel form, ¼ in. in thickness, and are spaced 5 ft. 5½ in. between centers. They are furnished with integral diagonal braces below the windows and with flanged gussets at the portal arches. The vestibule end posts consist of 9-in. I-beams framed into the sills and to the vestibule ceiling construction.

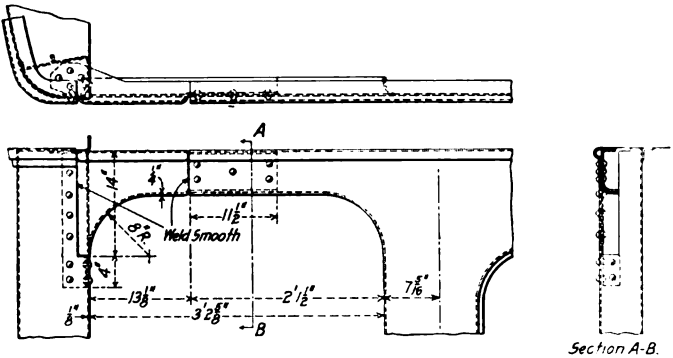

Detail of Vestibule Corner Post Connection to Side Door Header

The body end walls are fitted with ¼-in. pressed steel corner posts 12 in. deep, with gusset connections to the side sills and to the side plates of flanged form ¼ in. thick.

The roof structure is formed of pressed channel carlines, and is of the compound arch type. This form of roof is not

coil journal box springs and long quadruple elliptic springs under the bolsters. The proportioning of the springs is such as to produce the easy-riding qualities essential in steel car construction, not only for the comfort of the passengers but for the maintenance of equipment and roadbed. The trucks have an 8-ft. wheel base and complete, with clasp brakes and 33-in. wheels with 5-in. by 9-in. journals, weigh 12,500 lb. each.

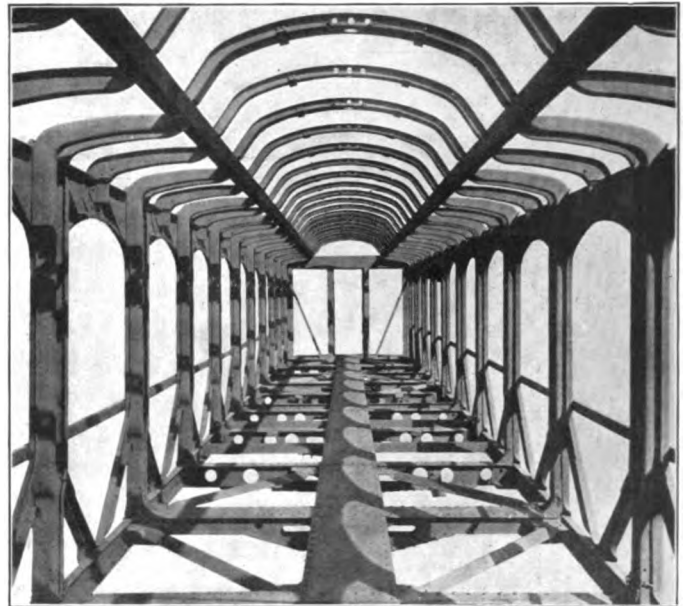

Interior View of the Completed Framing; Erie Suburban Cars

These trucks are designed with ample clearance for the application of electric motive power equipment, if at any future time their use in such service is required. Other features of interest on the trucks are Coleman bolster locking center pins which prevent the separation of car body from truck in case of derailment or collision, and clasp brakes, which greatly reduce brake shoe and journal wear and facilitate smooth stops, which is an especially desirable feature.

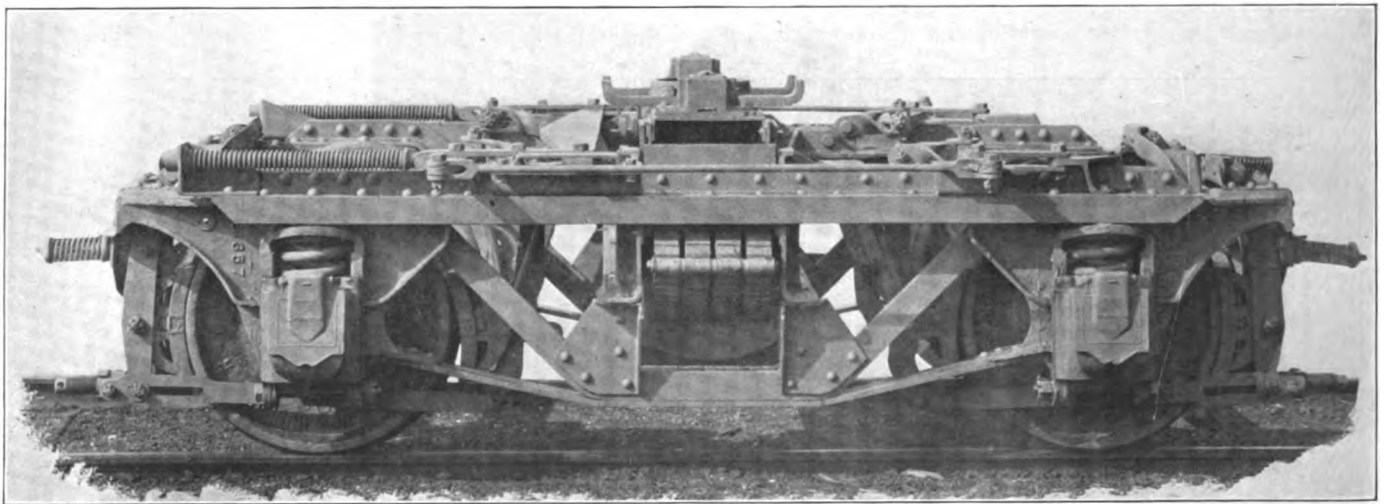

Truck Used on the Erie All-Steel Coaches

only strong, light and inexpensive, but gives good ventilation, good distribution of reflected light and is particularly suitable for the support of electric current collectors.

The trucks are 47 ft. 7½ in. apart from center to center and are of a non-equalized type, generally similar to those on the Westchester cars previously referred to. They are fitted with

The illumination of these cars is secured by eleven electric fixtures arranged in the center line of the car. One 25-watt lamp is used on each fixture. Power for lighting is furnished by an 800 ampere hour Wilson storage battery.

The equipment includes Miner Friction draft gear and buffing device; Pitt couplers and Hale & Kilburn seats.

SHOP PRACTICE

REDUCING PISTON VALVE LEAKAGE

BY V. T. KROPIDLOWSKI

In spite of all precautions in fitting up piston valves, there is a certain amount of steam that finds its way past the rings to the exhaust side without doing any useful work. The amount thus lost depends almost entirely on the practice followed in the repair shops in repairing and fitting up the valves. The methods established in one shop with which the writer is familiar have brought about a very noticeable reduction in steam leakage, and

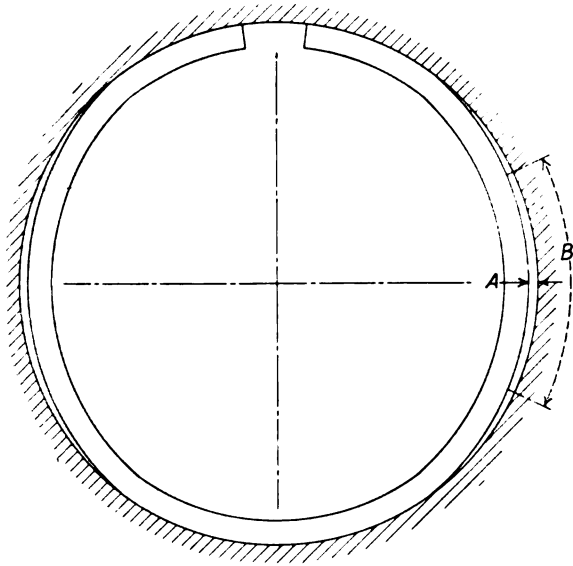

Fig. 1—Effect of Using Large Packing Ring

some of the tools developed for use in connection with this work are worthy of attention.

The practice quite commonly followed in railroad shops is to bore the valve chamber bushings to the exact diameter in the main shop, leaving the outside diameter to be turned to fit the chamber at the point of application. This has been found un-

satisfactory, as in every case, after a bushing has been pressed in, it is found to be out of round. There are two reasons for this: One is that the cylinder may have been warped from long service and the continual contraction and expansion; the other is that the bushing itself may be warped. Every casting tends to distort when the scale is turned off, due to the unbalancing

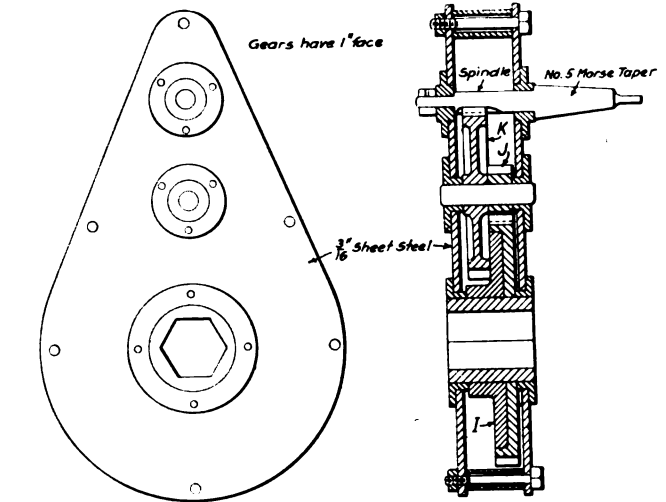

Fig. 3—Gear Train Used in Pulling In Valve Chamber Bushings

not to provide for boring the bushing after it has been pressed in the chamber.

Another practice, not in accordance with the best results, is the maintenance of stock sizes of packing rings. Because of this practice packing rings as much as $\frac{1}{8}$ in. to $\frac{3}{16}$ in. larger than the bore are being used in repair work. This results in oval instead of perfectly round packing rings when they are placed in the chamber. Actual measurements, taken at various times, of rings finished $\frac{1}{8}$ in. larger in diameter than the bushing, when in place in the chamber, have been found to vary from $\frac{1}{32}$ in. to $\frac{3}{64}$ in., as shown at *A*, Fig. 1, and a sheet of paper of the ordinary letterhead thickness, measuring .0025 in., could be slipped along between the ring and the wall of the chamber a distance of $4\frac{1}{2}$ in. to $5\frac{1}{2}$ in., as indicated at *B*, Fig. 1.

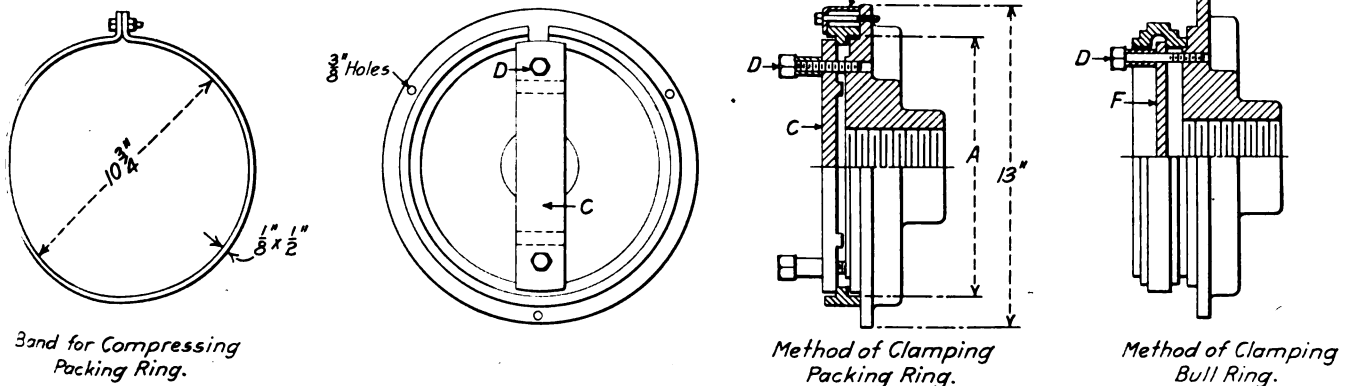

Fig. 2—Chuck for Finishing Valve Chamber Packing Rings and Bull Rings

satisfactory, as in every case, after a bushing has been pressed in, it is found to be out of round. There are two reasons for this: One is that the cylinder may have been warped from long service and the continual contraction and expansion; the other is that the bushing itself may be warped. Every casting tends to distort when the scale is turned off, due to the unbalancing

There is but one way to provide perfect fitting packing rings. After having turned the rings to the diameter that will give the required spring or tension, they must be cut, then closed and turned to the exact diameter of the chamber. To do this work the chuck, shown in Fig. 2, was made from a cast-iron piston head. The packing ring is first closed till the smallest diameter of its slightly

oval form is a little larger than the bore of the valve chamber, with a band clamp, and with the clamp in position is then placed on the chuck. The diameter at *A* is slightly less than the inside diameter of the ring, to permit centering it with reference to the outside surface, when the chuck has been screwed onto the lathe spindle. When centered the ring is firmly clamped to the chuck by the bar *C* and bolts *D* and the band removed, the bar *C* holding it in the closed position while it is turned. Old packing rings can be turned in the same manner. If the inside of old rings need truing up, clamps *E* are used instead of bar *C* to hold the ring in place.

Bull rings may also be turned up on this chuck, by using a shorter bar, shown at *F*, in place of bar *C*, the ends resting on the edge of the cored annular cavity inside of the bull ring. The same bolts may be used with both bars.

A very convenient arrangement has been also devised for pulling the valve chamber bushings into the cylinder. This is shown in Fig. 3 and consists of a threaded rod, two heads, one of which bears against the outer end of the bushing and the other against

PILLAR CRANE FOR MACHINE TOOL WORK

The pillar crane, the details of which are shown in the engraving, was designed especially for serving machine tools. It is very simple in construction and is easily rotated in the base. The pillar is a piece of 6 in. extra heavy pipe into the lower end of which is fitted a bottom bearing of cast iron. Into the upper end is fitted a cast steel post cap to which the end of the tension rod is secured. The jib member is a 7 in., 15-lb. I-beam secured to the post by a special cast steel connection which is riveted both to the beam and the post.

The pillar is supported in a cast iron base 3 ft. square and 3 ft. 9 in. high bored slightly larger than the pillar. A bottom bearing block is bolted to the base, in the upper face of which is a babbitt-lined hemispherical recess. In this and a similar recess in the pillar bearing runs a tool steel ball 2½ in. in diameter. The top of the base is counterbored to receive a housing 10½ in. in diameter, which contains a roller bearing running on the post.

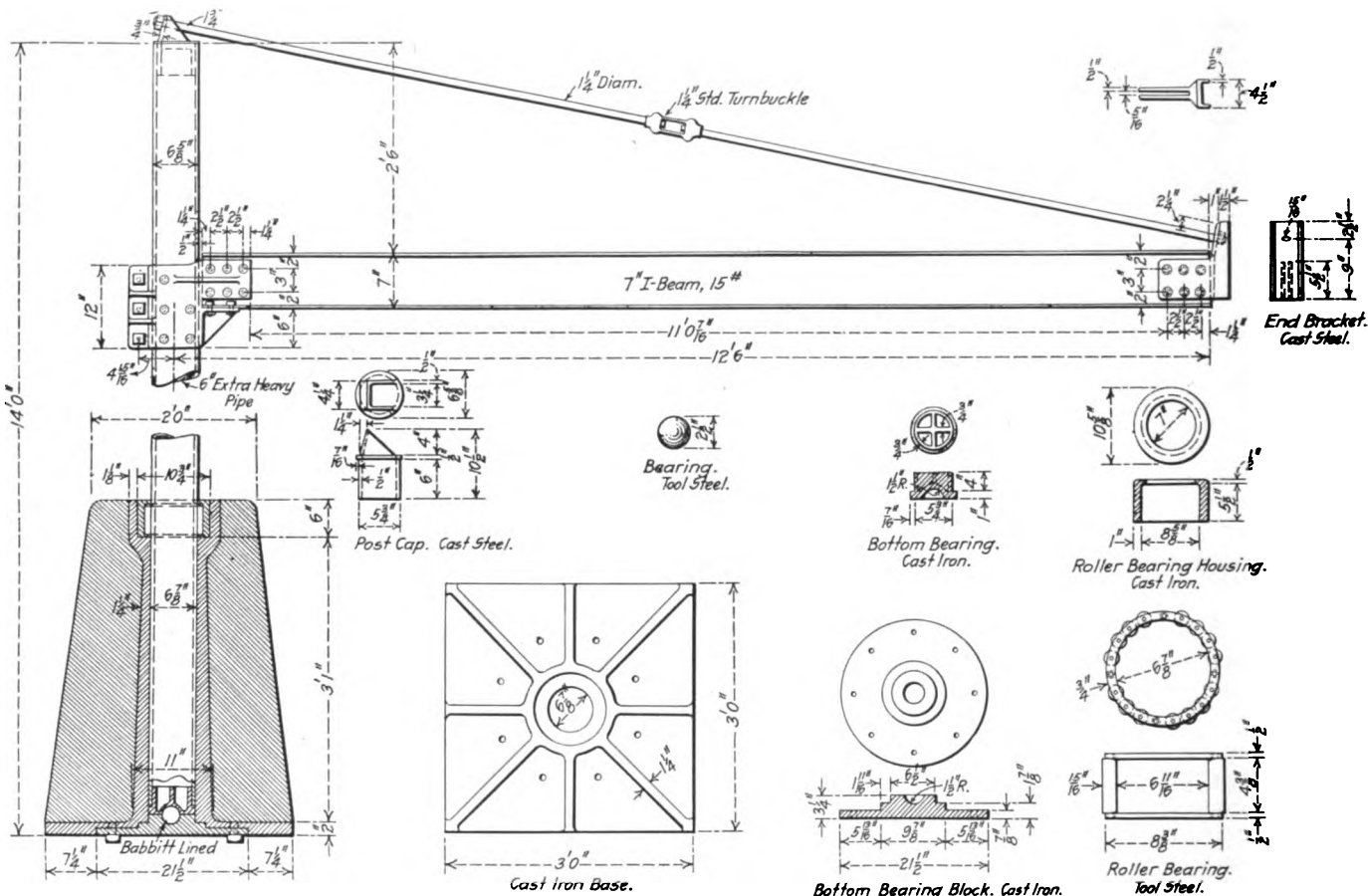

Details of Self-Contained Pillar Crane

the opposite end of the valve chamber, a train of gearing and an air motor. The gear train is assembled in a casing, an air motor is attached to the driving shaft and the hollow driven shaft is designed to slip over the nut on the threaded rod. The gear train is very powerful and enables one man to attend to the pulling in of the bushings. The pitch diameters of the gears and the number of teeth are as follows:

Gear I	11½ in. pitch diam.,	115 teeth
Gear J	2 in. pitch diam.,	18 teeth
Gear K	8 in. pitch diam.,	80 teeth
Spindle	1½ in. pitch diam.,	13 teeth

No tests have been made, either prior to or after the inauguration of the practice of maintaining piston valves herein described, to determine its effect upon leakage. There is, therefore, no specific data as to the amount of reduction effected, but general observations have shown that it is considerable.

When assembled, the base is embedded in the ground to a depth of about 12 in.

This crane was designed by A. L. Graburn, mechanical engineer, Canadian Northern, Toronto, Ont. It is used with a chain hoist, which is suspended from a four-wheel trolley mounted on the lower flanges of the I-beam.

DISCOVERY OF OXYGEN.—The discovery of oxygen is generally credited to Dr. Joseph Priestly, an English clergyman and scientist. The date, August 1, 1774, is commemorated as the birthday of modern chemistry. At about the same time two others made the same discovery: Scheel, a Swedish apothecary, who called it "fire air"; and Lavoisier, a French chemist, who called it oxygen, meaning "acid former." To Lavoisier is due the credit for the true explanation of combustion.—Power.

ILLINOIS CENTRAL TOOL SYSTEM

Standardization and Distribution Include a Central Tool Room with an Accurate Cost System

BY OWEN D. KINSEY
Tool Foreman, Illinois Central, Burnside Shops, Chicago, Ill.

The tool system of the Illinois Central is conducted along lines similar to those employed in a commercial manufacturing institution, as regards manufacturing methods and cost accounting. Centralization of functions is productive of economy. To maintain a standard shop practice throughout a railroad system there must be a standardization of tools and definite restrictions placed on their manufacture at outside points. Many standard tools, such as taps, drills, reamers, etc., can be purchased from the commercial tool manufacturers at a lower cost than they can be made in even a well equipped central tool room. It is therefore imperative that production costs be carefully compared in

costs, and although such expenses as those for jigs, dies, fixtures, small tools, lubricants, files, power, light and numerous other incidentals, enter into the manufacturing cost of tools they are often ignored in calculating this cost. It is therefore of prime importance that tool manufacture should be centralized and an accurate cost system maintained. The real function of the central tool room is therefore the standardization and manufacture of special tools and labor saving devices, such as cannot be profitably purchased outside. In this there is a broad field and many opportunities for economy.

STANDARDIZATION

Realizing the importance of standard tools throughout the system and the many advantages of centralizing their manufacture at one point, both from the standpoint of economy and that of standardization, a comprehensive central tool supply system has been inaugurated on the Illinois Central. Our first steps were to get away from the practice of making tools from worn-out samples and by hit-or-miss methods. A draftsman was assigned to the central tool room and a careful study made of each tool, considering efficiency, conditions under which it is used, safety and cost of manufacture. We went into the matter thoroughly, consulting the shop foremen and incorporating the very best ideas obtainable into a standard drawing, care being taken to eliminate overlapping sizes. These drawings were made up in standard folio size and copies of each mounted on cardboard for the convenience of the workmen. The value of standard drawings can hardly be overestimated. They relieve the foremen of lengthy verbal explanations and make it impossible for a workman to misunderstand what is wanted.

Several workmen can be assigned to the same job, each producing a certain part or number of parts, requiring no inventive or designing ingenuity on his part, as the article to be produced is clearly defined by the drawing. Consequently he produces more and better work, having a clear understanding of just what is wanted. Without a drawing, the average mechanic is quite likely to take his problem too seriously and make his work too expensive, being obliged to plan as he goes along, and the time thus spent would be taken care of once and for all if a drawing were followed. The fact is, when standard drawings are followed out and jigs and similar devices are used, a great increase in production results. Some of the least efficient workmen of the old system become the most efficient of the new.

Jigs, as a rule, are not expensive to make; in fact, they can in most cases be made up very inexpensively, providing artistic tool-making notions are secondary to performance and cost. It is nonsense to allow a skilled mechanic, whose time is more valuable for other work, to "putter" around with an elaborate set of fine instruments, laying out dimension lines to be followed by eye in the machining operations, when a simple, inexpensive jig will produce more accurately ten parts to his one in the same time. Such conditions are to be found in the smaller shops when tool making is undertaken, while repairs to jacks, hoists, pneumatic tools and other necessary shop appliances are sadly neglected.

CATALOG

All tools manufactured in the central tool room are listed in classified order in a standard tool catalog. This catalog is contained in a loose leaf binder so that it can be added to as the system grows. The catalogs are distributed to the several di-

MATERIAL		Size	W. T.	Price Per Lb.	Cost	LABOR - - \$ 17.89	
2nd Carbon		2 1/8	121	.11	13.31	OVER-HEAD	5.96
						MATERIAL -	13.31
						TOTAL - -	37.16
						PIECES - -	48
						COST EACH \$.77

Work Card Used In the Illinois Central Tool Room

justice to both the commercial tool manufacturers and the railroad.

It stands to reason that a small shop cannot produce good tools at a cost low enough to warrant their production, because it is not equipped for such work and cannot manufacture in quantities sufficiently large to obtain a low production cost. Moreover, a uniform shop practice is impossible, due to the varying ideas or notions of each individual foreman. Therefore, standardization is lost sight of and expensive duplicate jigs and devices are made and used at several points, while one device would serve the entire system, making all tools standard and resulting in a standard shop practice.

There is a natural tendency to underestimate manufacturing

vision storekeepers and master mechanics at the outside shops, and when tools are required a special requisition is made out giving the catalog number of the item wanted. This system eliminates all possibility of the order being misunderstood, providing the catalog number is correctly given, and also saves much time in writing. After being approved by the general inspector of tools and the superintendent of motive power, it goes through the general storekeeper's office directly to the central tool room to be filled.

STOCK

The tool stock is carried in the central tool room for convenience, although it is the property of the store department and is carried in their stock account. The tools are stored and handled in the same manner as the regular storehouse stock, being listed in the standard stock book from actual inventory taken on the first of each month. This record at all times shows the amount of individual tools in stock as follows: name of tool, catalog number, shelf or drawer, number on hand on the first of the month, number manufactured during the month, and number shipped. This is, in reality, a perpetual inventory.

The manufacture of stock tools is left largely to the discretion of the tool foreman, under supervision of the general storekeeper. It is of course, under this system, to his best interests that the stock be kept as low as possible, consistent with maintaining a good service to the mechanical department. All material entering the central tool room is charged to the cen-

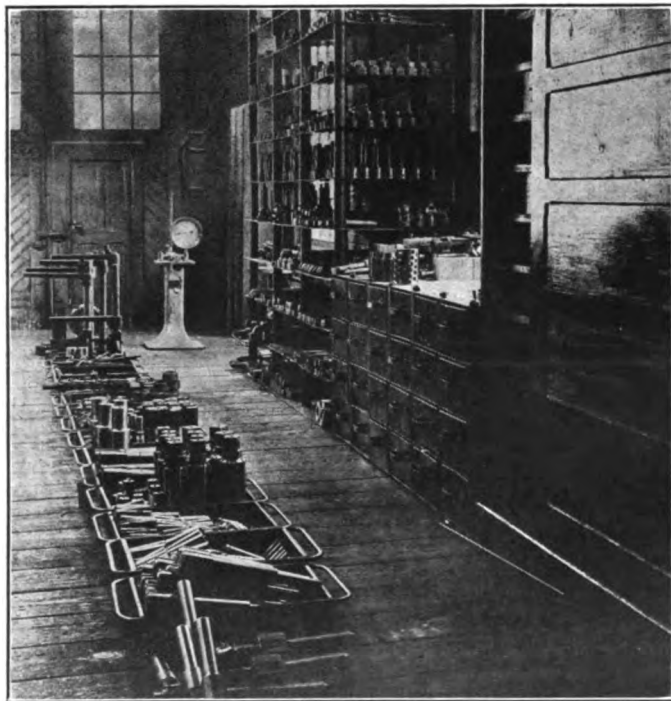

Stock Racks and Material In Process of Manufacture

tral tool room material account, which is designated by standing shop order No. 1,017. This material, after entering the central tool room stock, is still the store department's property and is listed in the stock book as raw material.

The manner in which the store department co-operates with the central tool room in supplying raw material for manufacturing purposes and information relative to commercial tool costs for purposes of comparison, emphasizes the ideal co-operative service between the supply and mechanical departments. A representative from the store department consults the tool foreman each month before sending in an order for manufacturing material, checking over item by item the material on hand and the possible requirements for the coming month. This plan eliminates the carrying of a large stock and guesswork on the

part of the stock keeper, who, without a definite understanding of requirements, would quite likely order a little of everything and still not have much of anything.

SYSTEM OF MANUFACTURE

When it is desired to manufacture a certain tool or a number of tools for stock, a tool room shop order is issued by the tool foreman. For instance, T. S. O. No. 246 is made out, which calls for the manufacture of four dozen 1½-in. straight expanders (without pins). As soon as the material is taken from the steel rack and the turret lathe work completed, the weight of material used is calculated from measurement and the grade and size, together with the weight, is entered on the

Check No. 346 A. L. 1-15-2000, Rev. 5-13 Con'l. Auditor Form 149

Illinois Central Railroad Co.

Date 6/16/15 1915 Ref of Pos. 39

Daily Time Record of E. Smith

Occupation Machinist

ACTUAL TIME WORKED					DESCRIPTION OF WORK PERFORMED (Give amount produced, etc.)	
STRAIGHT TIME		OVERTIME		HOURS		
COMMENCED	FINISHED	COMMENCED	FINISHED			
7 ⁰⁰ M.	8 ⁰⁰ M.	M.	M.	M.	1	3-a
8 ⁰⁰ M.	9 ⁰⁰ M.	M.	M.	M.	1	210 = 365
9 ⁰⁰ M.	11 ⁰⁰ M.	M.	M.	M.	2	210 = 271
11 ⁰⁰ M.	1 ⁰⁰ P.	M.	M.	M.	1 1/2	0
1 ⁰⁰ P.	1 ³⁰ P.	M.	M.	M.	1/2	2-70
1 ³⁰ P.	2 ³⁰ P.	M.	M.	M.	1	2-C
2 ³⁰ P.	3 ³⁰ P.	M.	M.	M.	1	2011513
M.	M.	M.	M.	M.		
P.	M.	M.	M.	M.	8	
TOTAL HOURS WORKED					8	

Time Verified by Check Remedy _____ Correct O. W. Miner

INSTRUCTIONS.
In column headed "Straight Time" show between what hours worked for which STRAIGHT TIME ONLY is allowed.
In column headed "Overtime" show between what hours worked for which TIME AND A HALF is allowed.
Penalty time must NOT be entered on this slip.

Tool Room Time Ticket

work card as shown in one of the illustrations. The material now changes from raw material to material in process of manufacture, and if at the end of the month when the account books are closed it is not complete, it is taken into inventory as semi-finished material. The work card shown is a true copy of an actual performance, and it will be noted that the unit cost is extremely low if compared with the cost of a commercial expander. The fact is, we have found that nearly all flue tools can be produced in a central tool room at a much lower cost than that for which they can be purchased.

The manner in which this particular job was done may be of interest. The first operation is performed on a 3 by 36 hollow hexagonal turret lathe, where it is shaped by forming tools to standard templates, drilled and cut off. The second operation is performed on a 24-in. radial tool room drilling machine, where it is chucked and reamed to size with a spiral taper reamer. The third operation is the sawing into sections on a triple head milling machine, three expanders being sawed at one operation. For the fourth operation the piece is passed to a bench hand who marks and separates the sections. The fifth takes place at the electric furnaces where it is hardened and drawn; and for the sixth, it returns to the bench for assembling.

All material in process of manufacture is handled in convenient metal pans which are lined up adjacent to the foreman's desk, as may be seen in the accompanying photograph. Each workman, when assigned to a shop order, takes the material from this section and returns it when his operation is completed. This plan prevents the work from being scattered around the shop and lost track of, and also enables the foreman to assign work with the least possible delay, a point very important in an efficient organization.

ASSIGNING WORK AND CHECKING TIME

All work is assigned from the foreman's desk and a time ticket, like the one illustrated, is handed the workman, to-

gether with a blue print defining the tool to be produced. For instance, the workman is started on T. S. O. No. 150 at 7 a. m., which starting time is entered on his time ticket by either the foreman or the time checker, who sits at a desk adjoining the foreman's. The workman completes his job and returns it, presenting his ticket to be assigned another job. The time finished is entered and a new job assigned, which starts at the same time he finished the previous operation, and so on, his record being kept in this way throughout the day. This system gives a correct time accounting and also records the performance of the workmen, a fact well known by them, resulting in a surprising increase in individual efficiency, the full meaning of which is better appreciated by reviewing the monthly expense and production statements.

Under the old system each workman kept his own time record, turning in a ticket at the close of the day's work. Nine times out of ten he would remember about half of the charges worked on during the day and then guess at the other half, some familiar general expense charge usually being used. A noticeable evil of the system was that the workmen would, in order to accommodate the foreman, knowing that he is trying to get a low production cost, cut off a little time from the actual time worked, to help matters along. The new system gives a correct time record. All charges are made to a T. S. O. account, or to the standing shop order in the event of some small job on which a cost has already been obtained. There is no general expense account such as shop machinery and tools or tool repairs. If time is spent in making repairs to a tool room machine or grinding tools, and similar work, the workman charges his time to account A, which is the central tool room expense account. This expense is taken care of when the books are closed at the end of the month.

SHIPPING

Tools for shipment to outside points are wrapped for shipment in the central tool room and delivered to the storekeeper.

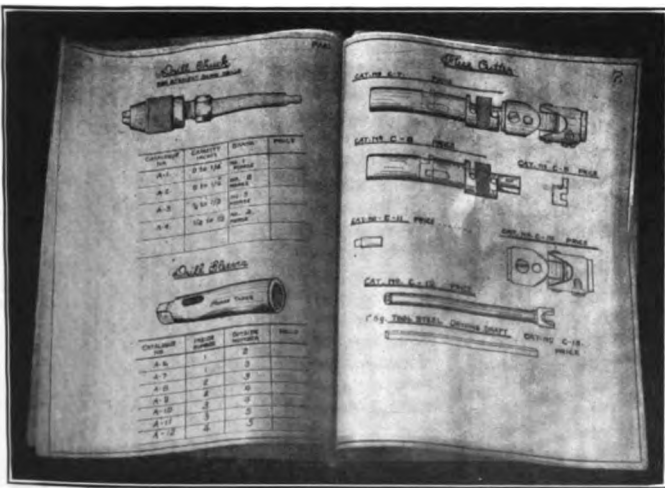

Illinois Central Tool Catalog

together with requisition showing the charges. If the order is filled in full, the requisition is held by the store department, but if not, it is returned after being checked with the goods delivered. The tool room copies the order into a record book when first received, which serves as their record.

ACCOUNTING

The pricing of goods shipped is done by the tool department. When a shipment is made up, the price of each article is entered on the requisition which goes with the goods to the store department, this serving as an invoice of the goods shipped. A double-entry bookkeeping system is maintained and the books are closed into profit and loss account at the end of each month to ascertain whether the selling prices are high enough to cover

all expenses. All work delivered from the central tool room is regarded as a sale and an entry made in the journal charging the consignee and crediting sales. A card index record of all goods shipped to outside points is kept for reference purposes. The Burnside shops are handled in the same manner as outside points as regards new tools.

For running repairs to small tools each department is designated by an account number as follows:

- 2-A Machine Shop Tool Repairs.
- 2-B Boiler Shop Tool Repairs.
- 2-C Blacksmith Shop Tool Repairs.
- 2-D Tin Shop Tool Repairs
- 2-E Round House Tool Repairs.
- 2-F Car Dept. Tool Repairs.
- 2-G 27th Street Round House Tool Repairs.

During the month a great number of small jobs are handled in the same manner as tool shop order accounts, as may be seen

330		Central Tool Room		
March 1915		Profit & Loss Account		
Dr.		Cr.		
Mar. 1	By Inventory	230319	By Outside Sales	79054
"	"	11/151	" Local	68917
"	By Oil Pack	15102	" By Inventory	200214
"	Total Pay Roll	18303	" " "	102472
"	Power & Light	3019	" " "	52152
"	"	6556	" Wash. Books	2202
"	"	522250	" Tool Issues	57162
				522250
April 1915				
Dr.		Cr.		
Apr. 1	By Inventory	200214	By Outside Sales	79760
"	"	102472	" Local	73537
"	"	52152	" By Inventory	313107
"	Total Pay Roll	183784	" " "	102407
"	Power & Light	3019	" " "	50783
"	Wash. Books	18320	" Wash. Books	14151
"	"	48281	" Tool Issues	55877
"	"	534222		534222

Tool Room Profit and Loss Account

from the accompanying facsimile of a time ticket. All of these charges appearing on time tickets are taken off in the shop timekeeper's office and distributed to the same account in the distribution book. At the end of the month the central tool room is rendered a statement showing the total time charged to each account, and is also given a total pay roll statement which includes all tool room labor and supervision expenses.

At the end of the month, when receiving this statement showing the total charges made against each department of the Burnside shops and shop order charges, we close our work cards or shop orders in the manner shown in the illustration. An overhead charge is used. These prices constitute our selling prices from which all goods are billed out. We dispose of Burnside accounts in the same manner, adding the overhead to each total, and then make an entry in our journals as follows:

May 31.	Machine Shop	Dr.	\$225.15	
	To Repairs on Small Tools,			
	Month of May.			
	Sales	Cr.		\$225.15
May 31.	Boiler Shop	Dr.	\$80.40	
	To Repairs on Small Tools,			
	Month of May.			
	Sales	Cr.		\$80.40

The next step is to close the ledger into profit and loss account. The total of sales shows us at a glance how much busi-

ness we have handled, while a comparison of the inventory taken on the first and last of the month shows the increase or decrease in the stock, etc. The store department renders a statement of material purchased at the close of each month, which, with the other debits and credits, enables us to close our books into profit and loss account, as shown in the illustration, and thereby determine whether or not we are covering our expenses.

The balance so far has appeared in the debit column, which indicates our selling prices are a little higher than necessary to cover the expenses. Our catalog prices are from 25 to 100 per cent or more lower than the commercial tool manufacturers' prices. If we cannot manufacture an article profitably we discontinue its manufacture altogether.

The many advantages resulting from business management can only be appreciated when comparisons with old methods are made. The central tool room has actually decreased its operating expense from \$1,856.80 in 1912 to \$1,337.84 (pay roll) in the same month of 1915. This has been done through reduction in force, there now being seven less men required in the tool department than three years ago, while the work handled has been more than doubled. It will be noted from the profit and loss statement that outside shipments and stock manufactured exceed Burnside orders, whereas but a short time ago the old tool room employed a larger organization at a much greater expense and handled very little outside work. Another noticeable feature of the new arrangement is the utilization of lower priced tool steel for tool manufacture. For instance, by inserting high speed blades in rose reamers, a reamer 2 in. in diameter by 16 in. long being considered, the cost of the raw material if made solid is \$8.86; cost for inserted blades as follows: Six pieces high speed steel 1¼ in. by ½ by 3¼ in. weighing less than one pound; and 14 lb. of soft steel worth 1½ cents per pound; or a material expense of approximately 71 cents.

The progress so far made only serves to emphasize the good that can be accomplished through business management in railway shops.

METHOD OF SECURING STEAM GAGES

BY W. S. WHITFORD

General Foreman, Chicago & North Western, Milwaukee, Wis.

The illustration shows a steam gage bracket to which has been applied a simple attachment for holding the gage in position without the use of bolts or machine screws. The device, originated by J. Linnehan, a machinist at this point, is easily made

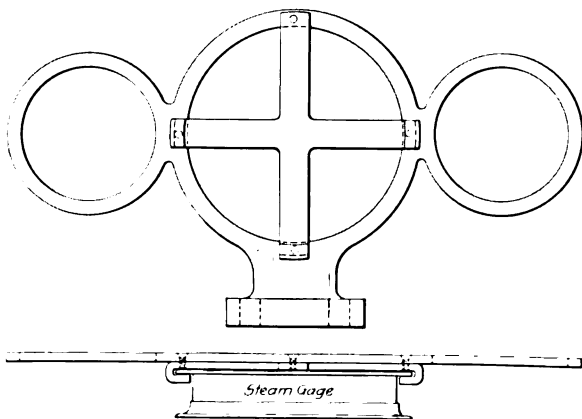

Attachment for Securing Steam Gage to the Bracket

from strips of 3/16 in. boiler steel, the ends of which at the bottom and sides of the bracket are bent so that they hold the rim of the steam gage securely in place when the pipe union is connected. By disconnecting the union the gage may be removed.

THE COST OF COMPRESSED AIR

BY THOMAS F. CRAWFORD

Twenty years ago when pneumatic tools were in their infancy the installation of an air compressor did not demand the careful study which is now required, because the wonderful saving in time effected by the substitution of air tools for hand tools overshadowed all other costs. Today, however, instead of a luxury to be found in only the best and most progressive shops compressed air is used in every conceivable plant from the two-stall roundhouse on some isolated branch line to the 40-pit main shop at division headquarters.

A careful study of the growth of the compressed air system in the average shop reveals the fact that the original system has been gradually extended by additions, owing to the many and varied uses to which the high pressure air medium has been applied. The original single stage, 200 or 300 cu. ft. compressor has been replaced by a cross-compound machine of 1,500 cu. ft. capacity; and it in turn has now been supplemented by still more modern and economical compressors with capacities ranging from 3,000 to 5,000 cu. ft. of free air per minute. Steel cars have revolutionized shop practice, and today the repair tracks are demanding from 500 to 3,000 cu. ft. of air, where 15 years ago all work was done by hand. This phenomenal development in many cases has bewildered the mechanical department to such an extent that, in spite of the best practice in air compressor construction and installation, enormous losses are daily incurred through improper piping and the lack of study devoted to the very important subject of air distribution.

The false economy of using the old piping as the system is extended is eating up hundreds of dollars every day in the boiler room and on the switchboard. It is a well known fact that the cost of air varies as the pressure varies; in other words it costs more to compress a cubic foot of air to a pressure of 100 lb., than to 50 lb. Consequently any arrangement of piping which will tend to reduce the initial pressure at the compressor will save money. Assume for example that a shop is piped for a certain size compressor and with the increased requirements the management finds it necessary to purchase a machine of double the capacity. Then, as is often the case, owing to the cost of the machine rigid economy is enforced as to further expenditures, with the result that the important question of piping is neglected. The old piping is considered good enough and only the necessary extensions to the car tracks or other important points are made. No engineering study of the subject has been made and the money saved at one end is going up the stack at the other.

This can readily be seen when a few facts concerning compressed air are considered. In the first place loss of pressure due to friction in pipe lines increases very rapidly as the diameter of the pipe decreases. The pressure loss when transmitting 500 cu. ft. of air per minute through 1,000 ft. of 3½-in. pipe amounts to 1.39 lb., with an initial pressure of 100 lb. per sq. in., while if the pipe size is cut down to 3 in. the loss of pressure jumps to 3.08 lb. Globe valves and fittings such as tees and elbows add greatly to the frictional loss and great care should be given to their application. It will, therefore, be seen that it does not require many poor conditions to build up an unnecessary load on the compressor.

Let us consider a compressor with a capacity of 3,000 cu. ft. of free air per minute operating during a 10-hr. day at approximately 100 lb. pressure and assume that by some rearrangement or replacement of piping the frictional transmission load on this machine is reduced 10 lb. What will the saving be? Under ordinary or even good railroad shop operating conditions it will amount to nearly \$3 per day which, in a year of 300 days, would be \$900. This represents the interest on an investment of from \$10,000 to \$15,000, which would go a long way in providing new piping and would pay for considerable engineering study.

Another phase of the subject which offers possibilities for considerable saving is the after-cooling and reheating of the air, particularly where the moisture is excessive and the weather conditions such that long exposed lines are greatly affected. This, however, is a refinement and may be left for investigation after the greater faults are corrected. It is mentioned here simply for the purpose of showing the extent of the field that is awaiting attention.

Pipe and hose leakage presents another source of loss which while appearing small, amounts to many dollars annually in railroad operation. Few master mechanics or shop superintendents realize what a leak signifies in dollars and cents. They know it amounts to something and that it should not exist, but their attention is taken up by things which are of more immediate importance as far as their daily duties are concerned. But when it is realized that for every leak amounting to 1/64 in. in diameter on a 100 lb. pressure line there is a loss of 1.2 cents per day, while for a leak amounting to only 1/16 in. there is the enormous loss of 19.35 cents per day, the subject of leaks assumes some importance. Add up all the leaks from New York to Chicago for instance, on one of our trunk line railroads and it will be found that there is quite a sum of money that is simply vanishing into the air.

In the ordinary railroad shop installation having a capacity of from 1,000 to 5,000 cu. ft. of free air per minute it is fair to assume that it is costing from 2.5 cents to 3 cents per day of 10 hours for every cubic foot of air per minute that is compressed, while in smaller plants where single stage compressors and other old types of machines are used, the cost may be much higher. This is particularly true in roundhouses and small shops using tubular boilers without feed water heaters. With these costs as a basis, another field of economy still greater than those already considered becomes evident. It is the operation and care of pneumatic tools.

Even ten years ago little attention was given to this important subject, and if the tools were lucky enough to get any attention it was probably from some handy man passing out drills and taps from the tool room window. The continuous and almost universal use of pneumatic tools today brings up the question not only of repairs, but of economy of operation. Instead of waiting until a motor or hammer is broken down before tagging it for the tool room it should be periodically inspected and repaired, and there should be kept a systematic record of the condition of each tool as well as the cost of its upkeep.

The air consumption of each tool should be studied. No up-to-date shop can afford to keep antiquated tools of obsolete design operating on its floor when it is realized that the cost of air is so great. Even the most modern four-piston air motor consumes from 50 to 60 cu. ft. of air per minute, and when it is considered that through wear or lack of attention it is often consuming 70 or 80 cu. ft., a loss in actual dollars and cents is evident, which will, many times over, pay for the repair parts and labor necessary to place the tool in first class operating condition, or even purchase a new one to replace it.

In order to emphasize the importance of maintenance, attention is called to the fact that on a full load basis for equal periods the cost of the compressed air required to operate an ordinary 35-lb. pneumatic drill used for such work as staybolt tapping, etc., is from two and one-half to three times as great as the cost of electricity to drive an 18-in. engine lathe.

The standard four-piston type air motor has a crank speed varying from 2,000 to 2,500 revolutions per minute, but as this is geared down at the spindle to a speed suitable for the class of work on which it is to be used the casual observer does not realize the amount of action taking place inside the metal casing. However, it is readily seen that with these little air pistons operating at such high speeds it does not require a great amount of false adjustment or wear to soon result in a large increase in air consumption. With the actual cost of air known and knowing the cost of the various repair parts, such as pistons,

bushings, valves, etc., it is an easy matter to determine the economic high and low limits for every tool and to establish a system by which repairs are made on a basis of air consumption tests rather than under present practice.

The apparatus necessary for testing air consumption and power developed, covering both pneumatic motors and hammers is inexpensive and can be operated if desired by a second or third year apprentice. Data can be kept in such shape that every tool will have its record on file covering both the tests made and the parts replaced. With such a system in operation, if an air motor, the card record of which shows a normal air consumption of 50 cu. ft. per minute, is sent in for test and is found to have a consumption of 60 cu. ft. per minute, on a basis of three cents per day for each cubic foot per minute, it is wasting 30 cents per day, or \$9 per month of 30 days. It will not require much calculating to show that regardless of the service which this tool may be giving it should go to the repair bench.

The same idea applies to the various types of hammers, all of which are at times eating up many times their worth when to outward appearances they are in first class condition. With a hammer, however, the waste is not so great, as it is held in the hand in such a manner that the operator becomes extremely sensitive to its operation and can often tell from "the feel" that it is taking too much air. However, the average shopman has never had impressed upon him the great cost of compressed air and his education in the matter by the methods now utilized in safety promotion work would undoubtedly result in eliminating many wastes.

A FEW FACTS ABOUT INSPECTING BOILERS*

To become a good boiler inspector does not require any especial gifts or qualifications. About all required is the necessary "know-how" and some horse sense, and the more of it the better for both inspector and boiler. The good inspector must know enough about boiler design to tell when a boiler is safe or not under the pressure desired to be carried. He must also be enough of a boiler maker to know when work is well or poorly done, and must be able to recognize errors and omissions in boiler construction as well as in its design.

The boiler inspector must have one faculty well developed, which is born in some people, can be cultivated by others, but which must be part of the mental make-up of every successful boiler inspector. This is the faculty of seeing things—the ability to take one look into a window and then describe more things than you thought possible to be placed in a room, much less a shop window.

Just line up the candidates for a position as boiler inspector, take them one at a time to a window, or a bank of shelves, upon which you have arranged in plain sight one hundred different articles—tools, bolts, nuts, familiar things pertinent to the boiler shop and its surroundings. With one hundred articles in plain sight, bring each candidate in front of the window or cabinet which is covered by doors or by a curtain. Tell each man that you are going to show him the things inside the cabinet for exactly ten seconds, after which he is to name each thing he sees. Draw aside the doors or curtain, give each man ten seconds and then immediately let him name the things he has seen and let a stenographer take down the names he mentions. If you don't have a stenographer handy, let somebody take down the names in long hand. If the man is not unusual, or trained in using his eyes, he won't see so many things that you can't write them all down in a few minutes. Sometimes, as in the case of candidates who are a bit diffident and apt to become confused, just give each man a pad of paper and let him write down the names

*From an article by James Francis, appearing in the June, 1915, number of The Boiler Maker.

himself. He can usually remember more of them when treated in this way.

The inspector's bag should always contain candles. They are not always to be had on the spot. Put in also a light hatchet-pene hammer and a small cold chisel. I always carried in my kit two light but strong steel chains and two small Yale padlocks. Whenever I had to go into one of a battery of boilers, I always made sure that the steam valve and the feed valve which prevented hot water or steam from reaching me from adjacent boilers were so chained and locked that they could not be opened while I was inside the boiler to be inspected. It doesn't do a man's nerves any good to hear a laborer working around the valves which cut his boiler from those under pressure on either side of him.

If there be any defect in a boiler, be sure you find it. That is what boiler inspection is for. It does no good to look into, over and under a steam boiler and not see everything there is to be seen. And here is where the training of looking at the articles in a window or cabinet comes into play, for the man who sees the most things in the cabinet can see the most things about a boiler, and, be these things good or bad, it is the inspector's business to see all of them.

"Whenever you see a head, hit it," is the only safe rule. Take absolutely nothing for granted. See everything and see just what condition everything is in. Perhaps you have gone all over a boiler and have found nothing wrong and you are at the front end, inside, with your head poked in among the braces, looking after the fastenings of the braces to the shell. Perhaps you have examined and sounded all the braces but one, and to get at this one you have to back out from your position among the braces, work your way around to the other side of the boiler and worm yourself in among the tubes again on that side of the boiler. In a case of this kind the temptation is very great to say: "There's nothing wrong with that brace—no use bothering to look at that one, for I have looked at every other brace in the boiler and they are all O. K.; probably that one is all right too, so I won't bother to crawl in and look at it." Don't you ever do such a thing, for if you do so you will be no good as a boiler inspector and might as well quit the business. There is a possibility that the brace you don't look at may be defective.

To emphasize the necessity for being always on the lookout and never slighting even the smallest thing in a boiler I want to tell about one thing that happened to me which led me to do more hammering and more poking around in corners where I couldn't see very well, and where there *might* be corrosion or cracks or deposit or some other weakening action going on in its hidden way. I had been all through, inside and outside, of a large return tubular boiler and had found nothing wrong, but intended to report adversely regarding the covering of the boiler, which was of brick, laid in arched form over the top of the boiler—a very bad arrangement, largely in use in cold latitudes several years ago, but happily seldom seen now. I was inside the boiler, had looked at both heads and had worked my way back to the manhole, in readiness to come out of the boiler. From some cause or other, not clear to me even now, I rolled over on my back and laid there a few seconds, looking around at everything I could see, and apparently everything was in good shape. I was just going to swing myself up into the manhole when a streak on the boiler shell about 2 ft. from the manhole happened to catch my eye, and from force of habit, I struck the spot with my hammer. I did not like the ring from that blow and struck the shell many times around and in that streak of rust; then I got out of the boiler, located the spot on top and tore off a section of the brick covering and laid bare the shell. I did more hammering there and dislodged a great mass of rust and corrosion where water from a leaky pipe overhead had been seeping down through the brick work upon the boiler shell for several years. When the boiler was shut down there was no water in the pipe and no leakage, hence no inspector had caught the fact.

After digging and hammering all the rust away the shell at the rusted place was found so very thin that a well-directed blow from the pene of the hammer went through the shell.

In the course of many inspections, I have found quite a number of defects which would have slipped past me had I ever taken anything for granted.

But as greatly as I was surprised over the boiler in question, my company was even more surprised a short time afterwards when they received a bill for repairs from the owner of the boiler in question. The bill was accompanied by a very short letter, requesting immediate settlement of the bill, and stating that it was sent to the insurance and inspection company for the reason that *their inspector broke the boiler!*

SYSTEMATIC VALVE SETTING ON LOCOMOTIVES*

BY J. R. BRITTON

Schedule Inspector, Angus Shops, Canadian Pacific, Montreal, Que.

Locomotive valve setters in the past have been left very much to their own resources, thus allowing various methods of valve setting with more or less difference in the results obtained. Systematic valve setting, when commonly understood and agreed upon, would insure definite methods which would be definitely stated to cover each design of valve gear on the various classes of engines, in order to develop maximum power and speed when working in the running reverse gear position. It would include an information sheet for the valve setters, containing lead specifications and other necessary points to be observed during valve setting. Some time ago a step was made in this direction by issuing information sheets giving specified full gear lead for the various classes of engines in the Canadian Pacific Angus Shops. The system recommended is to carry this still further, covering definitely all other necessary details relating to valve setting and establishing a common practice to be observed by all. This would be supplemented by a printed work report, which would be in itself a fair guide to the uninformed. This would be filled in by the man setting the valves and would render a statement of the various points necessary for accurate valve setting, showing that they had been properly observed. Lead and full gear port openings would be noted on the work report, thereby exposing any deviation from specifications immediately, which could be taken care of before the engine left for an outside point.

Valve setting is the most important work in connection with the construction or repair of a locomotive. In the past the tendency has been to set the valves on all classes of locomotives, *i. e.*, freight, switch and passenger engines more or less alike, but this system would allow of a definite valve setting to suit the conditions under which each class of engine works.

When a locomotive is taken into a shop for general repairs its motion is carefully inspected and all worn parts requiring repairs are taken care of by the machine shop. After this it is returned to the erecting shop, where it is re-assembled and put up, either by the man who is to set the valves or under his supervision. Under the system suggested all parts would have to comply with the standard instructions and in addition to this the valve setter would be expected to check the location and lengths of parts of the valve gear, particularly the reverse shafts, reverse shaft arms and in the case of Walschaert gear, combination levers, union links, radius rods, etc. No deviation from the first setting of eccentric crank arms or eccentrics would be necessary. After the valves are set the cut-offs are generally taken in order to prove the work. This time would be saved in many cases. Another advantage of such a system would be the establishment of a general understanding, which would eliminate the cost of further re-adjustments at outside points, owing to the difference of opinion.

*From a paper read before the Canadian Railway Club, April 13, 1915.

WELDING COPPER AND COPPER ALLOYS BY ACETYLENE METHODS

BY J. F. SPRINGER

Theoretically, the oxy-acetylene process of welding is applicable to all metals. The heat supplied is ample to fuse any of the metals, including even platinum. Practically, however, it has been found necessary to limit the process. There are so many matters that have to be cared for that it is no wonder that the commercial practice of a few years has not caught up with theory. Aluminum welding presented difficulties. These have been pretty well removed, so that today aluminum may be welded with almost, if not quite as much certainty as steel. Copper welding has proved more difficult still; and it has only been for a very moderate length of time that it could be done, even by a few operators, with commercial success. The difficulties have now been pretty well overcome.

It is the purpose of this article to set forth briefly the main lines of the practical advance. The reader is cautioned, however, not to consider himself a copper welder as soon as he has finished reading this account. In order to attain proficiency and certainty, he should go through a period of actually trying out his newly acquired knowledge upon work of little or no value. The present article may be regarded as a guide that points out the main matters, showing the acetylene welder along which lines success is to be expected.

While copper is the metal specifically treated in this article, the directions should be regarded as having greater or less application to its multitudinous alloys. Rolled commercial copper has a specific gravity of about 8.9. Copper in other forms will not vary greatly from this in its specific gravity. It is, accordingly, distinctly heavier than iron or steel. Its specific heat is 0.094; that of steel is 0.118. Accordingly, a less quantity of heat (20 per cent less) is required to raise the temperature of copper than is the case when dealing with steel. The temperature of fusion of copper is about 1,982 deg., Fahrenheit; that of steel is, say, 2,500. Copper is, consequently, not only easier to heat up, but the terminal point is very much lower.

In practical operations with the gas torch, the ease of raising the temperature to the welding point is more or less offset by the excessively high heat conductivity of copper. With the thermal conductivity of silver taken as a standard, those of copper and steel are, respectively, 73.6 and 11.6 per cent of that of silver. The parts of the copper work adjacent to the immediate region of welding carry off the heat more than six times as fast as would be the case if the metal were steel.

Taking all the foregoing facts into consideration, there is perhaps not much difference with copper work in the amount of heat that has to be poured into the joint than with steel work. Consider, however, other matters. The swift conduction of heat operates to create a wide zone of highly heated metal on either side of the joint. While the temperatures of these zones may be lower than those of similar zones in steel welding, still the fact remains that they are high relatively to the fusion point of copper, and this is what is important. The sluggish conductivity of steel enables local heating to be done without involving more than a narrow region on either side; the rapid conductivity of copper spreads the high temperatures to considerable distances.

The coefficient of expansion and contraction is for copper much higher than for steel. The result is that the contraction in the copper weld will go on more rapidly as cooling takes place subsequent to welding. The total amount of contraction is probably less than for steel, because of the much lower temperature of fusion; so that this is not the thing to watch, but the rate of contraction.

The wide zones of highly heated copper introduce a considerable difficulty, perhaps the greatest of all. Copper has the property of absorbing considerable quantities of oxygen from the atmosphere. The effect is to reduce the melting point for the affected

parts. Further, when just below its fusion temperature, copper passes into a condition of such a character that mechanical operations upon the metal tend to reduce it to a powder. If tensile strains occur while the copper work passes through the dangerous temperature zone, then cracks are to be expected.

In order to prevent burning of the metal through exposure to the air, it is advisable to protect in some way the regions to either side of the joint. One method of doing this is to provide a tough coating over the regions which may suffer exposure. Another is to supply through the welding rod some material which will spread over the work and nullify by its oxidizing power the effects of the oxygen in the atmosphere. But we must go further back than this. The very flame which supplies the heat is fed by a mixture of oxygen and a fuel gas. If there is an excess of oxygen in this mixture, we must expect this excess to operate against the copper itself. It is advisable, then, that the adjustment of the torch shall provide for a deficiency of oxygen, or, what is the same thing, for an excess of the fuel gas. In oxy-acetylene welding, the small, inner flame is a notable feature. For steel welding, this flame is white and is surrounded by a deep-blue, transparent enveloping flame. It is supposed that the inner flame, from a point just beyond the exit to the tip, or nearly to the tip, consists of carbon, hydrogen and oxygen in an uncombined state. The carbon and hydrogen are the products of the disintegration of the acetylene. Evidently, then, the copper work should not be exposed to the free oxygen in this inner flame. The condition of the flames corresponding to an excess of acetylene is indicated by the little inner flame becoming less sharply defined and assuming a yellowish color. This is the condition sought for copper welding. It is well to be familiar with the condition of the flames when the dangerous (for copper work) excess of oxygen occurs. This may be noted by the diminished size of the inner flame and the appearance of a violet color.

It is considered good to add a small amount of aluminum when welding copper. This aluminum may be added to the welding rod, and its percentage should not be more than 0.01. It is said to produce about the same effect as does aluminum when added to molten steel. It seems to act as a scavenger, gathering to itself the impurities in the pool of molten metal at the welding point. Since aluminum is itself very light, it will rise quickly to the surface.

The welding rod may advantageously contain a de-oxidizing material, such as phosphorus. It is claimed, however, that, if the de-oxidizing materials be other than phosphorus, then the introduction of phosphorus through the flame may result injuriously.

In the process of welding, more or less of the protoxide of copper will be formed. This will occur, in part at least, in the form of an alloy with metallic copper. It is necessary to get rid of it. Further, the de-oxidizing materials used in the welding rod will form combinations with oxygen. These must also be eliminated. A list of de-oxidizing materials follows: Tin, zinc, nickel, iron, manganese, phosphorus, silicon, aluminum, magnesium. These are given in the order of their activity, the latter ones having the greater activities.

In order to protect the heated surfaces to either side of the joint from the injurious effects of the atmosphere, a special powder may be employed. The powder may be spread over the surfaces in the form of a paste before beginning welding. The mode of operation of some of these powders is as follows. The heating of the metal results in melting the powder and the formation of a skin which covers the metallic surface and thus shuts out the oxygen of the air. Here a lesson may be taken from the art of hard-soldering. Borax is employed for just about the same reasons as obtain in welding. The borax must not be used in its commercial form, but must first be cleared of its water of crystallization; otherwise, the water is liable to decompose into its elements, whereupon we have free oxygen. Instead of borax, certain silicates may be used. Powdered glass, pulverized gravel or clay may be employed. However, we may

add to our powder ingredients which actively shield against oxygen by their avidity for it. A preparation of sodium, phosphorus, boron or magnesium is suited for this purpose. Pulverized wood charcoal may also be added. In compounding a welding powder, the rule should be observed to include no substance whose specific gravity is greater than that of the metal in the molten weld, otherwise, they can not be depended upon to rise to the surface and are pretty sure to become entangled in the material of the weld. In order to make the welding powder into a paste, either water or alcohol may be used. In this case, the water will not have the injurious effect which is to be expected from the water of crystallization. It will here be quickly evaporated instead of being decomposed into its elements.

It is considered important that the pulverization of the component substances in the welding powder shall be carried pretty far. The grains should in size approximate particles of dust. With rather large grains there is the possibility of vaporization or fusion of one before another; while, if the finely powdered condition obtains, the behavior is similar to that of an alloy. The average melting point for the powder must be below the melting point of the copper; and the vaporization point of the powder must at least equal the melting point of the metal. That is to say, the powder must melt but not vaporize during the welding operations.

In copper welding, the acetylene process is to be regarded as superior to the hydrogen procedure. Perhaps this remark should be made much stronger. Sufficient reasons for preferring the oxy-acetylene system consist, (1) in the avidity with which molten copper absorbs hydrogen gas, and (2) in the fact that one of the final products of the oxy-acetylene torch is carbon dioxide. This gas has the property of freeing copper of absorbed hydrogen. The importance of a clear understanding of this matter will justify a brief outline of the probable chemical reactions. In the case of the oxy-hydrogen torch, a mixture of oxygen and hydrogen issues from the tip; the oxygen combines with hydrogen and water vapor results. However, in practice, it is found necessary to supply hydrogen in an amount exceeding that required by the oxygen. No doubt it is this excess hydrogen whose burning by means of the oxygen of the air causes the existence of the enormous flame. The oxy-acetylene flame may be divided into three parts. The bright innermost flame is understood to contain oxygen, carbon and hydrogen in an uncombined form. Surrounding this bright innermost flame is a kind of envelope in which it is understood that the hydrogen remains as it is and the carbon is burnt to carbon monoxide. Finally, there is the large exterior enveloping flame where the hydrogen is supposed to be burnt to water vapor and the carbon monoxide to the dioxide. Now, even with the oxy-acetylene flame there is, accordingly, free hydrogen in contact with the copper. However, there are two considerations which enter here: the amount of hydrogen is only 7.7 per cent of the total weight of the acetylene; carbon dioxide is formed in considerable quantity, and has the before-mentioned property of eliminating hydrogen from the copper.

Another advantage of the oxy-acetylene procedure is cited by a writer in *Autogene Metallbearbeitung*. This relates to the protective activities of the outermost flame. As the mixture of gases coming from the tip, even when the torch is used normally, supplies only a slight excess of oxygen above that necessary for the burning of the carbon to carbon monoxide, the bulk of the oxygen needed to burn the hydrogen and the carbon monoxide is derived from the atmosphere. In other words, the outermost flame is an active, de-oxidizing agent, robbing the air of its power of injuring the copper. The oxy-hydrogen flame is doubtless to be preferred when the cutting of steel is in question; but with copper welding, the oxy-acetylene process is certainly to be preferred. The respective fields of activity differ at these points.

The careful reader will, in the light of the foregoing facts and explanations, perceive sufficient reasons for certain rules of procedure. In copper welding, the torch is held vertically and not obliquely. The effect sought is to divide the outermost flame

into two wide-spreading tongues covering the work on either side of the joint in an extensive manner. We are thus protecting the highly-heated adjacent metal from the oxygen of the air. This procedure may at times even be sufficiently effective of itself to warrant us in dispensing with the welding powder. In such cases, it is recommended that the welding rod be of pure electrolytic copper.

If the work consists of thin copper plates whose thickness does not exceed $\frac{1}{8}$ in., their edges may be joined without the use of a welding rod. The edges should be bent up so as to project above the surface an amount equal, say, to the thickness of the sheet. The two bent-up edges are placed together, and the torch operated vertically and in such a manner as to melt down the double ridge. In order to protect the work on either side, welding powder in the form of paste may be applied. The portion painted should be perhaps an inch broad on either sheet of metal. The powder should be applied also to the summit of the double ridge. Care should be exercised not to use too much paste or powder.

Copper welding requires promptness in execution. If the welder lingers too long, the powder or paste will be exhausted and the oxygen of the air may have opportunity of attacking the work. If the welding rod supplies de-oxidation material, this material too may become exhausted by delay. If a piece of welding has once been done and it becomes desirable to go over it again, fresh powder or paste may well be applied before beginning. Accordingly, the welder should not return to a point once passed without giving attention to this matter.

It has already been pointed out that copper is a very rapid conductor of heat. The welder should bear in mind that this conduction will operate downwards as well as to right and left. It is advisable, therefore to arrange beneath the region of the zone of operations a heavy sheet of asbestos or similar material. It is recommended that before beginning actual welding this asbestos sheet should be heated by the torch along the region of the future weld; the object is in part to drive out any contained moisture. Following this application of heat, welding powder or paste should be applied to the asbestos, thus guarding the work on the under side. The presence of the asbestos beneath the joint has also the advantageous effect of assisting in preventing a dissipation of the heat and consequently in facilitating the welding.

If the work consists of thick copper plates—plates having a thickness in excess, say, of $\frac{1}{8}$ in.—then the opposing edges may be beveled just as is done with iron and steel welding. A welding rod will be ordinarily employed in these cases; asbestos may advantageously be used beneath. Also, it will probably assist in most cases, if asbestos sheets are laid upon the work to either side of the path along which the torch is to operate. Indeed, in some cases, such protection against loss of heat may be imperative, because otherwise the heat might be carried off with nearly as much rapidity by the work as it is applied by the torch.

Copper welding requires a sure hand; quickness without hurry will often be demanded. At times, it will be necessary to move along the seam with increased rapidity. This necessity may become so urgent that difficulty is experienced in getting the welding rod to melt rapidly enough. It is advisable, in order to be ready for this situation, to use a welding rod whose diameter is considerably less than the thickness of the copper sheets of the work. An idea of the proper rapidity of conducting the work may be gained from the accompanying table of acetylene consumption.

Thickness of copper plate, in inches	Acetylene consumption per hour, in cubic feet
0.08	7
0.12	11½
2.00	21
3.20	35

It is pertinent to call attention to the fact that the impurity of the oxygen used affects the temperature of the flame. With pure oxygen a temperature of 7,200 deg. Fahrenheit seems attainable; but if the oxygen is only 95 per cent pure, the impurity being

assumed to be nitrogen, then the temperature will drop to, say, 5,400 deg. This temperature is sufficiently high to effect fusion, but the loss is felt in the increased difficulty to pour into the work a sufficient amount of heat. Where oxygen is prepared by electrolytic means, the impurity will probably be hydrogen gas, itself a fuel. Apparently, then, such oxygen is to be preferred to that obtained by the liquefaction of the air.

To recapitulate certain main points; copper welding must be done with a torch adjustment providing for acetylene in excess of the amount used in steel welding. Care should be taken not to permit the innermost flame to touch the metal. The torch is to be managed vertically in such a way as to throw a branch flame to either side of the joint. The work must proceed uniformly and with considerable rapidity. If no de-oxidation powder or paste is employed, it is advisable to use electrolytic copper for the welding rod. Under all conditions where a rod is employed, its diameter should be distinctly less than the thickness of the work. Thin sheets may be welded without a rod by melting down turned-up edges; in this case, the welding powder or paste should be applied not only to either side of the joint, but also upon the double ridge formed by the turned-up edges. In copper welding, asbestos may advantageously be used beneath the region of the joint and also on top at a short distance to either side of the joint; the asbestos beneath may profitably be heated in advance and treated with welding powder or paste. A de-oxidizing powder or paste may usually be used to advantage. De-oxidizing and purifying materials may be employed as ingredients of the welding rod. An oxygen free from any considerable percentage of nitrogen should be preferably employed. Acetylene rather than hydrogen is preferable for use in the torch used in copper welding.

APPRENTICE SCHOOL CAR

The photograph reproduced below is believed to show the first apprentice school of its kind. The school-room occupies a passenger coach which has been fitted up specially for the purpose with drawing tables, blackboards, etc. The school is conducted jointly by the Staten Island Line of the Baltimore & Ohio and



Interior of Staten Island Apprentice School Car

the Board of Education of the City of New York. The Board pays the salary of the teachers, who in this case are employees of the railroad, and also pays for the material used. Apprentices are allowed pay for one-half time while in school. Drawing is be-

ing taught by Harry Lawrence, shop draftsman, and mathematics by J. W. Rissik, special apprentice. The school was started in the fall of 1914.

CAUSE OF HIGH SPEED STEEL TOOL FAILURES

BY GEORGE J. BRUNELLE

Among the petty troubles of the modern shop manager there are none perhaps more annoying than the frequent failure of high speed tools. Once a shop has been supplied with a brand of steel advertised to "take heavy cuts at high speed" no further trouble is anticipated; yet tool failures occur frequently, and with tool-smith and machinist denying their responsibility, the causes are hard to trace. Literature on the subject is scant. Authorities write volumes on carbon steels, but about high speed steels they are strangely reticent. Consequently, it devolves upon the man interested (the toolsmith) to find out for himself, by sly experiment and surreptitious visit to the machine shop, the causes of tool failures.

Nearly every failure is laid at the door of the toolsmith. The usual way is to return the tool to him with instructions to "try it again." For some reason the machinist's judgment is seldom questioned. Whatever the reason, it does not seem good, because with a machinist tools are an incidental, while with a toolsmith they are a specialty, and ours is a day of specialists and experts. Now a good toolsmith is an expert. He should know approximately the possibilities and limits of each tool, the use to which it is to be put, and should have, besides, a general knowledge of every machine on which forged tools are used. Constant study of everyday problems arising from tool failures cultivate his judgment so that he is seldom in error in placing their cause.

Properly speaking, high speed steel is not a pure metal. It is known as an alloy or mixture of metals. Each brand has a different formula and the elements in them vary in number from 15 to 20. It cannot be welded and differs from carbon steel in that it retains its density and hardness at high temperatures. It cannot be hardened as hard, nor annealed as soft, as carbon steel. Roughly speaking each one of those 15 or 20 elements affect the quality or properties of the steel. Some give hardness at the expense of toughness and others vice versa. Thus of the different makes (and there are sometimes a dozen or more in a shop) some are hard and brittle, while others are not so hard but tougher, making them more reliable where delicacy of form is necessary.

It is a common error to conduct a "test" of different brands of steel by using them for the same kind of tool on the same kind of work in the same machine. The form commonly used is a tool of strong section, and this is generally used at high speed and heavy cut in the hardest material at hand.

Now the very properties that make a steel highly efficient under these conditions are usually the cause of its failure when made into a tool of delicate shape, and used in ordinary material. A test is not thorough unless it meets ordinary conditions. This is proved by everyday experience, and by the fact that the same steel is not always the winner in different shops. Good authorities hold that there is no brand that can fulfill both requirements—great hardness and great toughness, selling agents to the contrary notwithstanding. Yet when a toolsmith is given a piece of steel to make a tool, he must get maximum results or the management threatens to get another toolsmith.

Assuming that a steel is at hand that serves general purposes fairly well, there are several causes that will make it fall below its general standard. Chargeable to the toolsmith are:

- | FORGING | HEAT-TREATING |
|--------------------------|---|
| 1—Heating too fast. | 5—Over-heating. |
| 2—Not heating uniformly. | 6—Kept at high temperature too long. |
| 3—Over-heating. | 7—Not heated enough to get maximum high speed properties. |
| 4—Forging too cold. | |

Thus we find seven possible faults in a properly shaped tool,

each of which will impair its usefulness. Now for purposes of comparison let us consider a tool to have avoided these and enumerate some other faults that would prevent its coming up to its standard:

DUE TO GRINDING	
Cause	Effect
Too fast on dry wheel.....	Soft edge
Too fast on wet wheel.....	Cracks
Not ground enough.....	No edge
Too much clearance.....	Crumbles
Too much rake.....	Breaks
Too much shear.....	Breaks
Ground to negative rake.....	Breaks
Not enough shear.....	Cuts rough and seems dull

DUE TO ABUSE	
Cause	Effect
Too much overhang.....	Tool chatters
Material not annealed.....	Tool seems soft
Too much speed.....	Tool seems soft
Chip too large.....	Tool breaks
Chip too small.....	Tool not under scale
Gritty material.....	Tool seems soft
	Tool edge grinds off

On summing up we find that the chances of the tool being spoiled in grinding are even and when in use these are two to one against the machinist.

And there are yet other causes not chargeable to either smith or machinist that may nullify their best efforts toward producing a good tool. The steel may be incapable, at its best, of sustaining its edge at the required speed, perhaps a cheap steel or one intended for tools of delicate shape, where toughness is a primary consideration. It may also have been forged in a coal fire that had an excess of sulphur and phosphorous, both deadly poisons to steel, or a furnace of "home make" where the heat is forced through the steel from one side. Last, and by no means the most uncommon, is a wet air blast, which is sure to cause a tool to "flake off the top."

It is evident, then, that the placing of the blame for tool failures is a matter requiring much experience and good judgment. They should be carefully inquired into and corrected, for with high speed steel costing from 45 to 85 cents per pound, it would seem worth while that not only the selection and forging be done carefully and economically, but that some one should see to it that the user of the tool grinds it right and when it is sharp that he stops grinding.

JIG FOR SETTING UP CROWN BRASSES IN THE SHAPER

BY LOUIS LEBOVITZ

A simple jig is shown in the drawing which facilitates the clamping of driving box brasses to the shaper table for finishing the corners. It may also be used on a bench or a surface

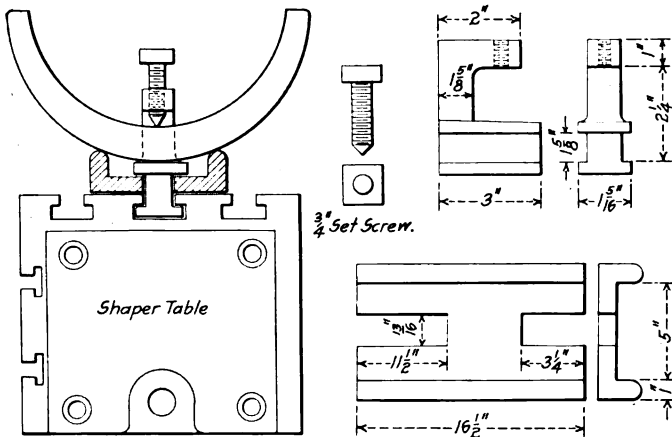

Jig for Holding Crown Brasses on the Shaper

plate provided with tee slots, to hold the brass while chipping. The channel plate rests on the shaper table and is provided with slots in the ends. The bases of the clamps are inserted

into a tee slot in the table, and when the brass is in place the clamps are slid into the slots in the channel plates and the whole rigidly secured to the table by tightening the set screws.

TRAINING OFFICIAL MATERIAL AND JOURNEYMAN APPRENTICES*

BY F. H. THOMAS

Supervisor of Apprentices, Atchison, Topeka & Santa Fe, Topeka, Kan.

Seven years ago the Santa Fe System was greatly crippled on account of the difficulty in getting efficient mechanics. There were not enough to go around. The throttling effect of the labor organizations in limiting the number of apprentices, had practically driven the apprentice system from the shops and country, and had reduced the supply of mechanics way below the demand. The railway company inaugurated its present system of educating and training its own men. The scheme was successful from the start; we are getting the best boys of the community, and are rapidly filling our shops and offices and stations with the best class of men in the country, energetic, ambitious, honest, and loyal. We select boys whom we deem fitted for their chosen work, exercising a great deal of care.

We have now turned our heads toward a method of selecting official material from this young army. The management has said we must promote our own men and not go outside for officers. Such being our orders, how can we make the selections? We employ a number of college men each year, calling them "special apprentices." The college man is generally chuck full of learning, but distressingly lacking in horse sense or application. So we have been called upon to establish a special course or plan for developing official timber. We select a limited number of graduates of the best technical or engineering schools, and the same number from the ranks of our regular journeyman apprentices who are just finishing their apprenticeship, and require them to pursue a well defined course of training. We require the college man to work one year on machines, another year on the floor, bench, or erecting work. The journeyman apprentice who has been selected for the course, has already served three and one-half years in the above branches. We then require him to work four months in the roundhouse, the real mechanical heart of the operating department of a railroad system. Then he goes in the boiler shop for two months; then in the freight-car shop for two months; then assisting road foreman of engines for two months; finally finishing the year as inspector of incoming and outgoing engines at shop and terminals. During each of these periods he is provided with a course of reading and study and required to write a letter every thirty days, giving a detailed account of the work he has performed, observations, suggestions, etc. His letters are criticized by the supervisor of apprentices and pointed suggestions are made to him. He is urged to select some officer whom all recognize as a successful one, and closely observe his method of conducting the duty of the office, especially observing his method of handling men. This latter phase is the most difficult; good managers of men are few. Every movement of the young man is closely observed. If he falls down in any branch of the course he must pursue it over again. If he fails to develop along the desired line he is put back at his trade. If he fails under fire or at any critical moment, he is corrected and his weakness pointed out. At the first act of disobedience or semblance of insubordination, "off comes his head."

Selections of men for this course are not made in a day, but are the fruit of two or three years of observation and study. Favoritism and pull will not count for much in the selection of the future Santa Fe officers. The reward will be to those of real merit, who have been specifically trained for the place.

*From an address delivered before the convention of the National Association of Corporation Schools, held at Worcester, Mass., June 8 to 11, 1915.

NEW DEVICES

DRIVING WHEEL LATHE

A 90-in. driving wheel lathe, in the design of which are embodied several features of interest, has been placed on the market by the Niles-Bement-Pond Company, New York. It is considerably heavier than any previously brought out by them.

A feature of considerable importance in the operation of this machine is the pneumatic clamping device for the right-hand headstock. This is operated by a large air cylinder controlled by a conveniently located valve, the power from which is transmitted through a rack and worm device to the clamp which secures the head to the bed at both the front and back simultaneously. This headstock is also equipped with a power traverse operated by a separate motor which is placed within the bed to save floor space. The motor is connected to a screw through a friction clutch which is controlled by a lever located so that the operator may traverse the headstock without leaving his position near the tool post. The clutch is so adjusted that it will slip when excessive power is applied, thus eliminating the possibility of damage to the machine in case the face plate should be brought too forcibly against the wheel. The motor is readily accessible for inspection and repairs.

The face plate gears are of the internal type and are driven by pinions located at the front of the machine. The pinions are placed approximately on a line with the tools, thus tending to counteract the strain from the tool and to relieve the main spindle bearing of considerable pressure. All gearing on the lathe is enclosed. The internal gears attached to the face plate

are provided with guards at their sides to protect them from chips and dirt, and the driving and speed change gears are enclosed within the left-hand headstock. Doors through the front

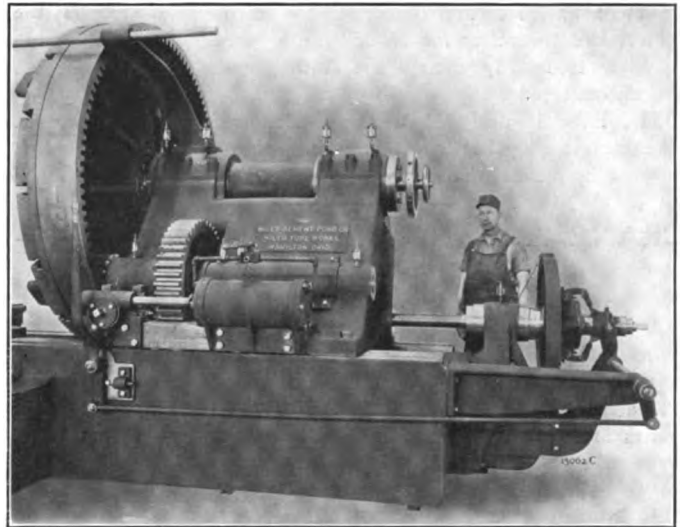

Mechanism for Traversing and Clamping the Head Stock

of the headstock provide access for inspecting the mechanism. Pneumatic tool clamps of a type similar to those included in

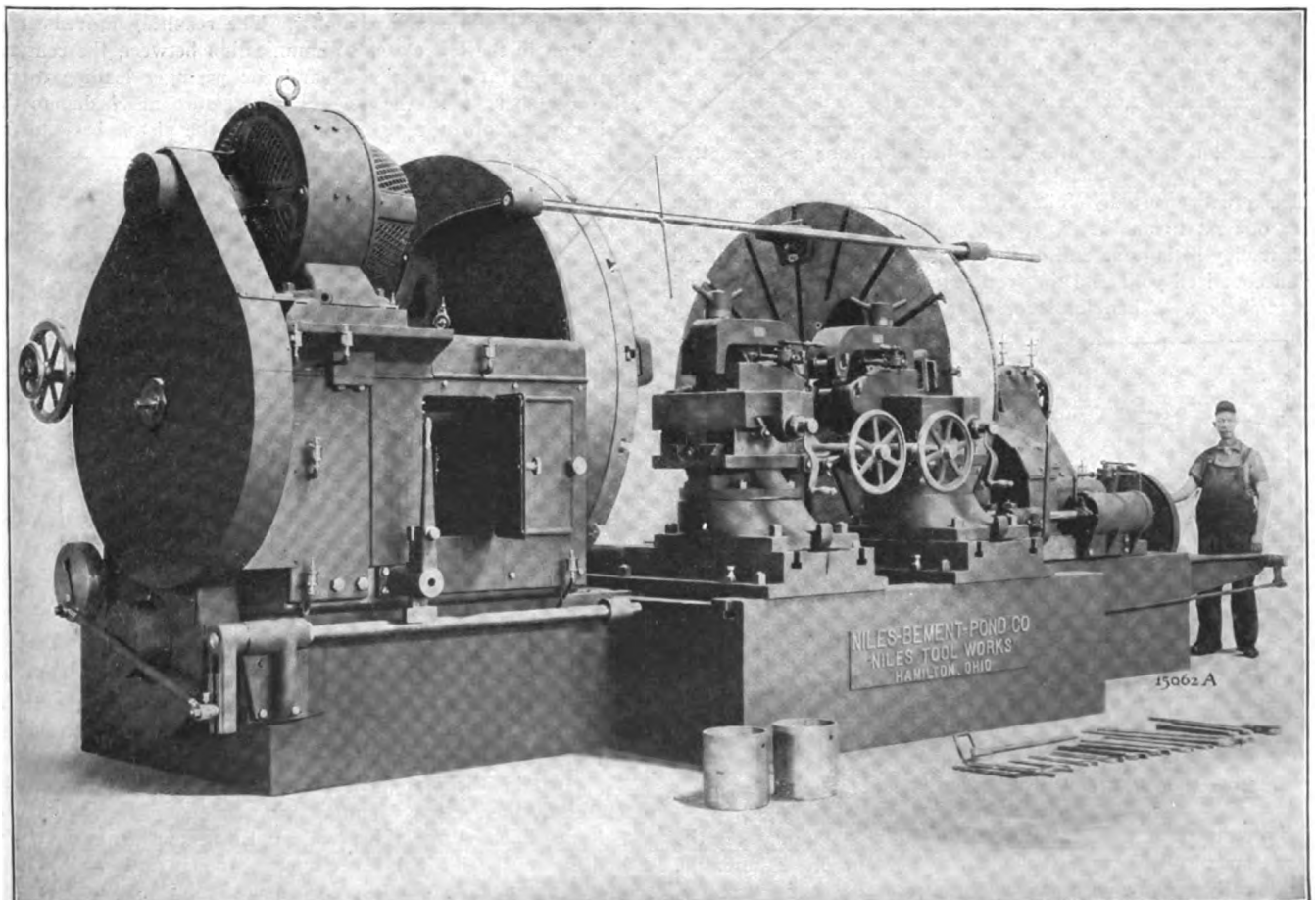

Heavy Model 90-In. Driving Wheel Lathe

previous models are used on this machine. They enable the operator to change and clamp tools in a few seconds without the use of a wrench, and are so designed that the tools are positively locked independently of the air pressure. The lathe is equipped with a calipering device to enable the operator to readily finish both wheels to the same diameter. This consists of an adjustable pointer supported by a bar rigidly attached to the left-hand headstock and having a sliding bearing in its right-hand bracket. The equipment also includes push-button control for direct current motors. Two push-button switches are suspended near the cutting tools, one for starting and stopping the motor, and the other for reducing the speed. This enables the operator to readily control the cutting speed when hard spots are encountered.

The lathe is designed to take axles with outside journals. The centers may be drawn back into the head stocks for this purpose by means of hand wheels on the ends of the spindles.

CRANE ARRANGEMENT FOR LOCOMOTIVE SHOPS

A traveling crane arrangement permitting a reduction in head room in locomotive erecting shops of the cross-stall type has been designed and patented by H. Shoemaker, mechanical superintendent, Bangor & Aroostook, Derby, Me. Two parallel cranes are used in lifting the locomotive, the spacing being so arranged as to permit the locomotive to be raised between them.

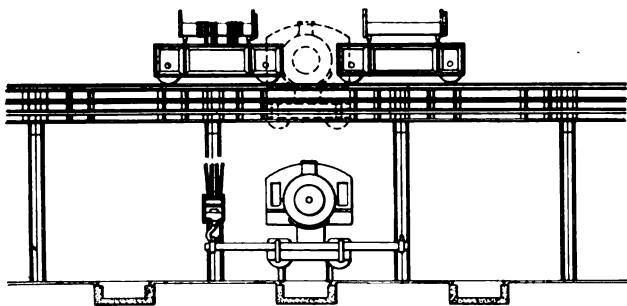

End Elevation of Cranes Showing Method of Lifting a Locomotive

The practice usually followed in transferring a locomotive from one pit to another is to use one crane with two trolleys, each trolley lifting one end of the engine. The rear end is lifted by an equalized yoke and the front end by a sling placed around the smokebox. When the locomotive is lifted from the floor to

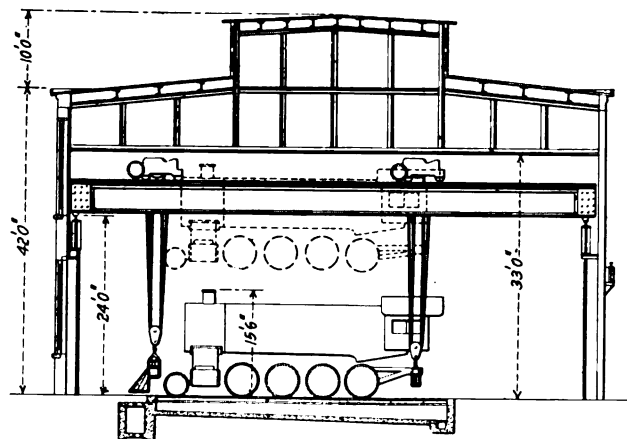

Cross-Section of Erecting Shop with Reduced Head Room

a height sufficient to clear other locomotives standing on the floor it must still be considerably below the bottom of the crane. This usually requires a clear height under the roof trusses of not less than 48 ft., and the height at which the crane is carried

requires structural work of heavy design. Owing to the limited wheel-base of a single crane the entire load is lifted and carried by one pair of track girders.

The new arrangement consists of two connected traveling cranes adapted to traverse the runway coincidentally and separated by a space sufficiently wide to clear a locomotive when hoisted between them. Hoisting yokes equal in length to the distance between the center lines of the two cranes are placed under both the front and rear ends of the locomotive, the hoisting being accomplished by four trolleys, two on each crane.

Several advantages are claimed for this arrangement. Owing to the reduced head room required the height of the building may be made approximately 15 ft. less. A similar reduction in the height at which the crane is carried is also effected. This lowers the cost of the building and considerably lightens the structural work required to carry the cranes. Shorter and lighter columns may be used and the track girders may be made lighter because of the distribution of the load over a much longer wheel-base. The length of wheel-base is sufficient to distribute the load over three girder sections when lifting an engine; in no position will it be concentrated on one section.

AUTOMATIC DRIFTING VALVE

An automatic drifting valve for use on superheater locomotives is shown herewith. It is known as Wood's vacuum breaker and its operation is controlled by the pressure in the live steam passage of the valve chamber.

The device has four pipe connections: Pipe *A* leads to the live steam passage of one of the valve chambers or to one of the steam pipes; pipe *B* to the turret, or other source of constant boiler pressure, and the two pipes *C* to the live steam passages of the valve chambers. When the throttle is open the plug piston in the large chamber at the end of the valve body is subjected to the pressure in the valve chamber. The resulting movement of the piston to the left closes communication between the constant steam supply at connection *B* and the passages leading to the valve chambers. On the release of pressure at *A* due to the closing of the throttle the spring forces the piston back to the

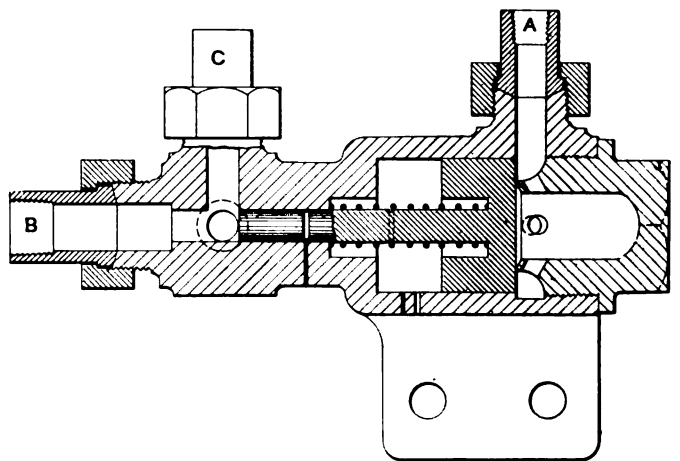

Drifting Valve for Superheater Locomotives

right, opening the communication between connection *B* and passages *C* and admitting a limited supply of steam to the valve chambers, which provides a medium for carrying and distributing the lubricant over the valve chamber and cylinder walls.

A patent has been applied for on this device and it is manufactured by the Nathan Manufacturing Company, New York. It has been subjected to service trials and its performance is understood to have been highly satisfactory. It may be located at any convenient point on the locomotive, preferably near one of the cylinders.

CONTINUOUS MOTION HAMMER BOLT HEADING MACHINE

More than half of all square, hexagon and tee head bolts are the product of the hammer type of bolt heading machine. In the operation of the usual design of these machines the output, both in quantity and uniformity, is dependent entirely upon the physical ability of the operator and the care exercised by him. The labor involved in operating the machine is considerable, the

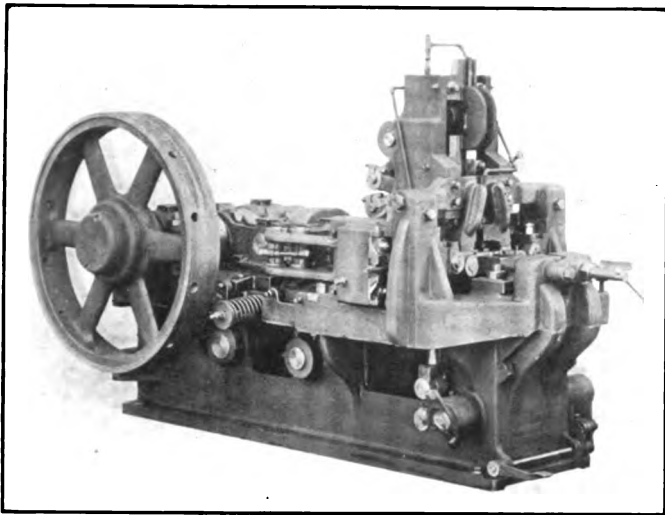

Continuous Motion Semi-Automatic Hammer Bolt Header

movements of gripping, starting and stopping the machine for each blank introduced and each bolt completed, being performed by means of hand levers. These movements induce fatigue, and as the fatigue increases, the efficiency of the man and machine decrease. The number of blows used in making a bolt also depended entirely upon the watchfulness of the operator, and it is common, where the operator's attention is lax, to find bolts of

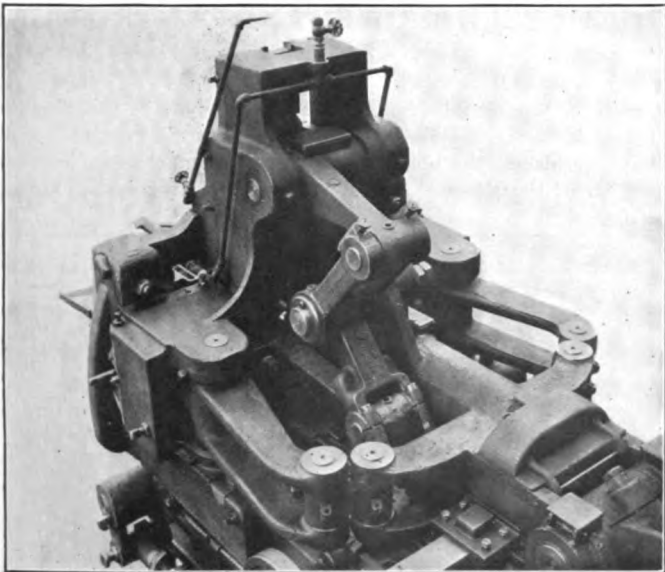

Link Motion for Operating the Hammer Levers

supposedly one quality and finish varying greatly, due to the lack of uniformity in the number of blows received.

A new hammer heading machine has recently been developed by the National Machinery Company, Tiffin, Ohio, in the operation of which the manual labor has been considerably reduced. The gripping, starting and stopping movements are effected auto-

matically, and the operator's entire attention and energy may be devoted to feeding the machine. The main shaft, heading slide and the hammer slides of the machine run continuously as in a rivet header so that the machine in a measure sets the pace for the operator.

A feature of the design is the ability to set or time the machine to deliver any predetermined number within a range of three to eight blows in each cycle or operation. The machine thus set, the finish of the output is necessarily uniform. The length of time that the grips are open for feeding can be regulated to suit the needs or ability of the operator and according to the length or type of bolt being made. These changes are effected through a simple gear and cam device.

The bed of this machine is of the box type, of large proportions, and is constructed to secure rigidity as well as strength. Owing to its greater rigidity a four-blow bolt made in this machine is said to be equal to a five or six-blow bolt produced in machines of the usual design. The bolt being made in less blows and less time, there is a better flow of the metal to fill out the corners. It is also possible to work the metal at lower heats, reducing the tendency of the metal to bulge at the top and sides of the bolt head.

Another departure in this design is the lever construction for

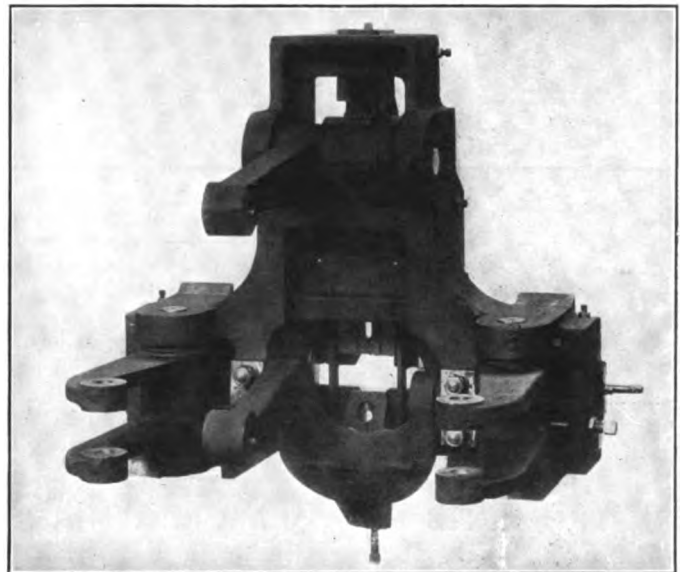

Yoke Construction of the Lever Carrying the Lower Hammer

carrying the lower hammer. This is usually carried in a slide the same as the side and top hammers; scale from the bolts as they are being forged drops on this slide, and together with the action of the water, results in excessive wear and disalignment of the lower hammer. The lever construction eliminates this wear. The side and top hammer slides in this design are operated by bronze bushed links in place of cams and rolls. The cam construction has been eliminated because of its excessive wear, and the fact that it promotes spring and lost motion in the hammer slides.

The fly-wheel is of the National friction-slip construction, which acts as an automatic safety device in case cold stock or an excess of metal is gripped in the dies and obstructs the travel of the heading tool. This fly-wheel also serves as a protection to the motor when the machine is direct motor driven.

The rigid construction combined with the mechanically operated grip makes it practicable to introduce a cut-off attachment in the gripping dies, so that short bolts can be made directly off the rod. Contrary to usual conditions, with this shear or cut-off in the grip dies short bolts are made with even more ease and facility than long bolts; four to six bolts may be made in one heat, depending somewhat upon the diameter of the stock and length of

the bolts. An automatic relief is also provided on the gripping mechanism to protect the machine against damage should the operator accidentally get stock or some foreign object in the grips in such a way as to prevent the dies from closing.

The slides in this machine have been made extra long, and bronzed bushed shaft bearings of large diameter have been used. The main shaft bearings are self-oiling and careful attention has been given to lubrication throughout; all oil cups or pockets are provided with hinged or sliding covers to exclude dust and scale.

The new continuous motion, semi-automatic machine is built in sizes of 3/4 in., 1 in. and 1 1/2 in. capacity, for either belt or motor drive. The rigidity of the construction has practically doubled the weight of these machines, as compared with others

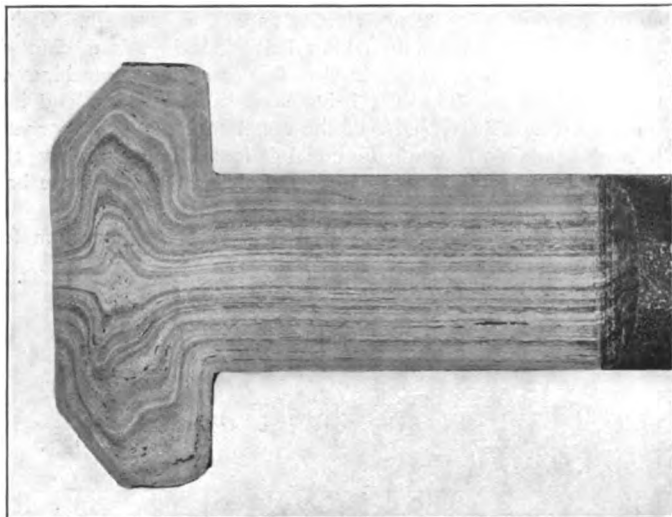

Etched Iron Bolt Made on the Continuous Motion Hammer Header Showing Unbroken Metal Fiber in the Head

of similar rating; the one-inch header weighs approximately 13,000 lb. With this greater weight, however, the speed of the machine is high. The one-inch machine runs at 140 r. p. m. on its maximum work, which can be materially increased when running on smaller work.

INSTRUMENTS FOR MEASURING HARDNESS AND ELASTICITY OF RUBBER

In the manufacture of rubber goods, the process is not under economic control, such as is now common in metal production. It is not exactly known why in rubber working a pure raw material does not guarantee the finest finished article when subjected to a given heat treatment. When an article of fine quality is produced it has been impossible to tell without destroying it, just what the physical properties are which favor a given result and hence the manufacture goes on with no more enlightenment than before.

The two principal physical properties of rubber are hardness and elasticity, and instruments for the measurement and comparison of these have recently been brought out by the Shore Instrument & Manufacturing Company, 557 West Twenty-second street, New York. These instruments, shown with their leather pocket cases, are known as the durometer and elastometer respectively and may be used either by hand or in connection with a small operating stand.

Hardness is measured by the durometer in terms of the resistance to depression of a plane surface by a standard spring pressing on a blunt pin. The surface of the rubber is not broken in any event, and it may therefore be used on finished articles. The elastometer measures elasticity in terms of resistance to permanent deformation or tearing under the action of a moderately sharp pin which is caused to penetrate the material. In

applying the instrument the point is caused to penetrate the material by moving downward the knob on the side of the instrument. The relation of the edge of the point and the depth it is caused to penetrate, has been carefully determined by experiments on extremely elastic rubber. If the elasticity is quite perfect, no tearing or permanent injury results and the point will be

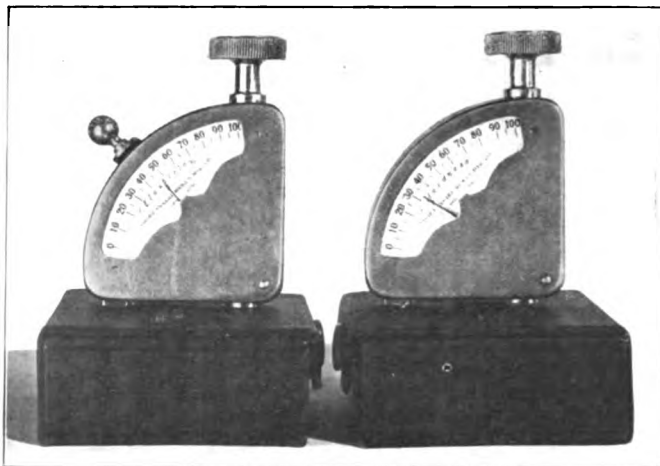

Elastometer and Durometer for Measuring Elasticity and Hardness of Rubber

completely ejected upon unlocking it by raising the knob. The extent of its ejection is shown on the scale of the instrument in per cent of the total penetration. The extent of the recovery of the material thus indicated corresponds to the percentage of elasticity as measured by the older form of stretch test. The new test has the advantage of being applicable to the plane surfaces of finished articles and leaves practically no visible mark.

These instruments are principally for the use of manufacturers of rubber to aid in economic production and the buyers of rubber goods in formulating purchase specifications and inspecting goods, as well as for research work.

HIGH SPEED BLOWER AND CENTRIFUGAL AIR COMPRESSOR

Among the obvious faults of the usual type of paddle-wheel fan or blower is the shock with which the air is received by the impeller blades, the abrupt turns and sudden changes in cross-section of the passages through which the air flows. The sup-

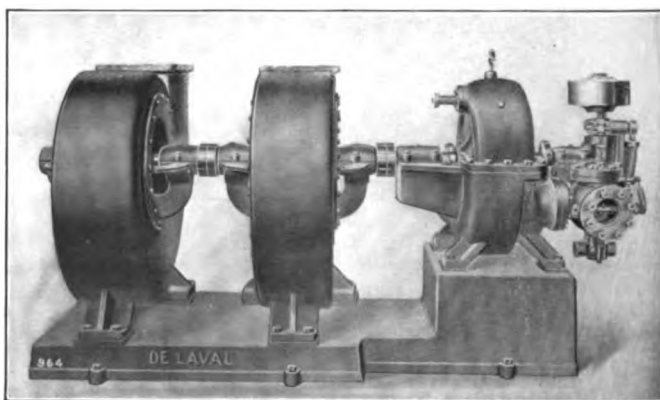

Two Single Stage Blowers Direct-Connected to a De Laval Velocity-Stage Turbine

ports for the floats or vanes obstruct the flow of the air, and the amount of surface in contact with the air moving at high velocities is large, resulting in considerable loss by skin friction. The

efficiency is low and the action noisy, and as ordinarily built, the fan is bulky, due to the slow speeds required because of structural weakness and lack of balance. The so-called multi-blade fans, which to some extent have replaced the paddle-wheel fan, run at still slower speeds for the same pressures and volumes. Neither type of fan is suited for direct connection to the modern high-speed rotative prime movers, such as the steam turbine and

the connection of the blower or compressor directly to the turbine in nearly all cases.

The construction of a single-stage type of blower is shown in the sectional drawing. The housings of blowers of the double-suction type are in one piece, usually of cast iron. The bearing bracket is cast integral with a circular inlet ring or bell, fitting into the eye or opening of the casing, the opening being of sufficient diameter to permit removal of the impeller. The housing is so formed as to provide an efficient diffusor and volute, the discharge opening of which is provided with a flange for the attachment of piping. The bearings are of the vertically split babbitt-lined ring-oiled type, formed in separate shells resting in the brackets, or in exceptional cases, in pedestals.

The impeller is built up on a disc of heat-treated chrome-

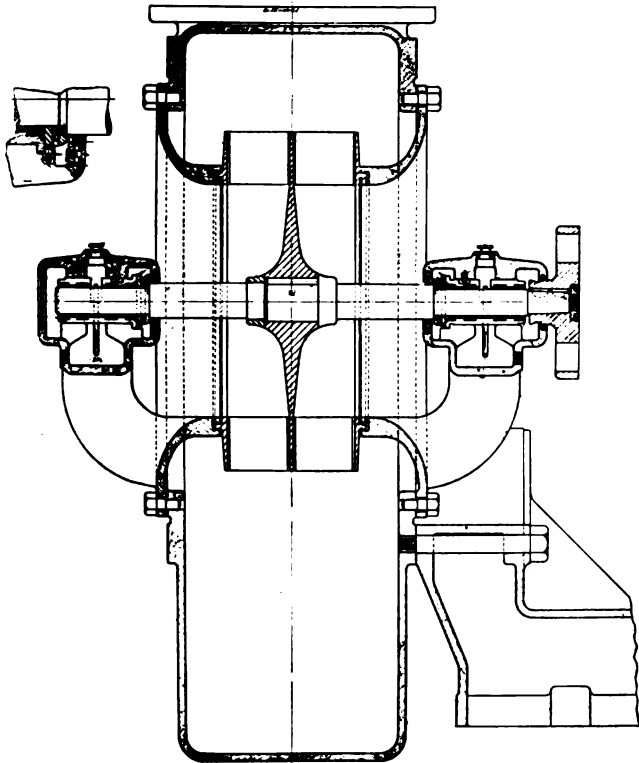

Sectional View of a Single Stage Double Suction Blower

the electric motor. The DeLaval Steam Turbine Company, Trenton, N. J., by employing the same materials and workmanship used in building its turbines, has found it possible to run centrifugal blower and compressor wheels safely at peripheral velocities of 450 to 600 ft. per second, rendering practicable the generation of 3 or 4 lb. pressure per sq. in. in a single-stage blower, and

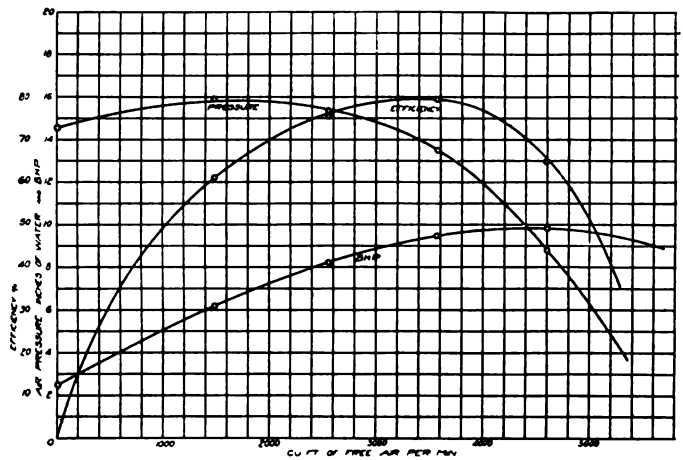

Characteristics of De Laval Single Stage Motor-Driven Blower

nickel steel, thickened at the center to form a hub, and also to turn the air which enters axially to a radial direction with the least shock. One side of each blade or vane is riveted directly to this disk, while the other is riveted to a steel side plate of the same material as the hub and also turned tapering to combine strength and lightness. The entrance edges of the blades are set at such an angle as to receive the air without shock and are formed to give the desired characteristics. Attached to the side plate is a ring which meshes with a corresponding groove in the inlet ring, thus forming a labyrinth packing which minimizes leakage from the discharge past the impeller back to the suction.

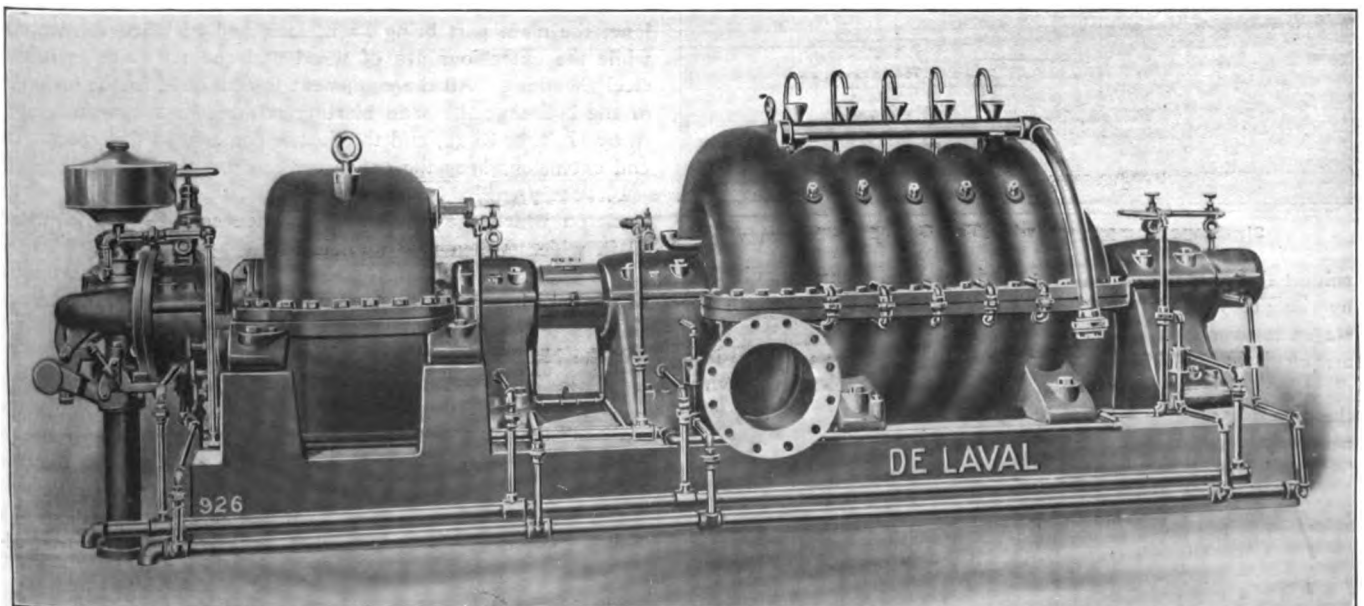

Six-Stage De Laval Centrifugal Air Compressor Driven by Multi-Stage Turbine

The shaft is made from special hammer-forged, open-hearth steel of a high tensile strength and uniform texture, ground in dead center grinders to insure absolute accuracy of dimensions, perfect centering and high finish.

These machines are employed for pressures ranging from four to six inches water column up to three to four pounds per square inch. The form of the head-delivery characteristic can be modified according to the work to be done.

The casing of the multi-stage compressor is split horizontally, permitting the top half or cover to be lifted off so that internal parts may be inspected and lifted out after the removal of the bearing caps. The impellers are mounted upon a shaft of large diameter, the critical speed of which is far above the running speed. It is made from hammer-forged open-hearth steel, suitably heat treated and ground and polished over the entire surface on dead center grinders. The hubs of the impellers are keyed to the shaft and separated from one another by shaft tightening rings which run inside of split packing rings attached to the diaphragms in the stages. Where gases other than air are handled, double carbon rings are placed at each end of the casing, in addition to the labyrinth rings surrounding the impeller suction inlets and the packing rings on the shaft. The diaphragms between stages are separate from the casing and are divided on a horizontal plane so that they may be removed without removing the shaft and impellers. When cooling is employed, the diaphragms are hollow, the water entering through the bottom of the casing and escaping at the top.

The impellers are of the single-suction shrouded type, and are built up on heat-treated chrome-nickel steel disks, the blades or vanes being riveted to the disks and to side plates, turned tapering to give strength and lightness. That part of the disk which is within the circle of the suction opening is subjected on the inlet side to the suction pressure and on the back to the discharge pressure of the individual stage, which gives a re-

than 2,000 cu. ft. per min. is usually not practicable. The larger machines for these pressures or machines which must run at motor speeds, are usually built in two sections, with separate shafts and housings, the speeds available with electric motors of these sizes requiring either a compressor with a large number of stages and several housings, or the use of a step-up gear, by

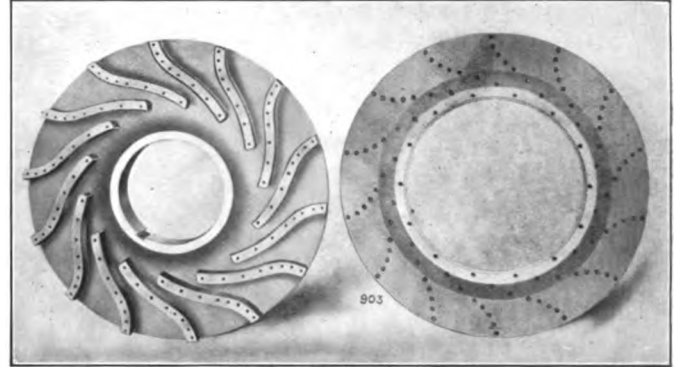

Impeller Disc and Side Plate of Multi-Stage Air Compressor Showing Method of Attaching Vanes

which the compressor can be operated at 4,000 to 5,000 r. p. m.

Where either strictly constant head or strictly constant rate of delivery is required, speed variation or throttling of the suction is resorted to.

SAND BLASTING STEEL CARS

It has been a difficult problem in connection with the use of steel cars to clean the exterior in a satisfactory manner before painting. The use of acids for this purpose is not entirely satisfactory and this method is also dangerous for the workmen.

The matter of cleaning has assumed increased importance with the general advent of the steel passenger car, and where sand blasting has been adopted it seems to have been productive of remarkably good results.

The engravings show side elevation and sectional views of a sand blast installation which is in successful operation on a large system operating a great many steel cars in both passenger and freight service. The installation was designed by the Pangborn Corporation, Hagerstown, Md., who also manufactured and supervised the erecting of the equipment which is known as their model "P" car cleaning installation.

As shown in one of the illustrations the building is 172 ft. long, the main part being 55 ft. long and of brick construction, while the extensions are of wood and covered with corrugated steel sheathing. All the equipment is contained in the main part of the building; the sand blasting is done in a compartment 12 ft. by 17 ft. by 21 ft., and the dust is confined to this space. The end extensions keep the entire car indoors at all times.

Pits are provided, as shown in one of the sections, beneath the track on which the car stands and are covered with a grating 10 ft. wide. When new sand is necessary it is dumped on this grating and passes down the sloped sides of the pits to the elevators which are of the bucket type and which carry the new sand as well as that which falls from the sides of the car during the blasting operation, to the sand separators. These sand separators remove any refuse from the sand, the good sand passing into the sand bins and the refuse into the waste bins. From the sand bins the sand goes to the blasting machines which are operated by compressed air, the sand passing from the machine to a hose and nozzle in the hands of the operator who stands on the platform shown. Canvas curtains, as indicated on the drawings are arranged so that the section of the car standing over the grating is entirely enclosed.

The engravings also clearly show the arrangement of the exhaust piping which is designed to remove the dust rapidly from

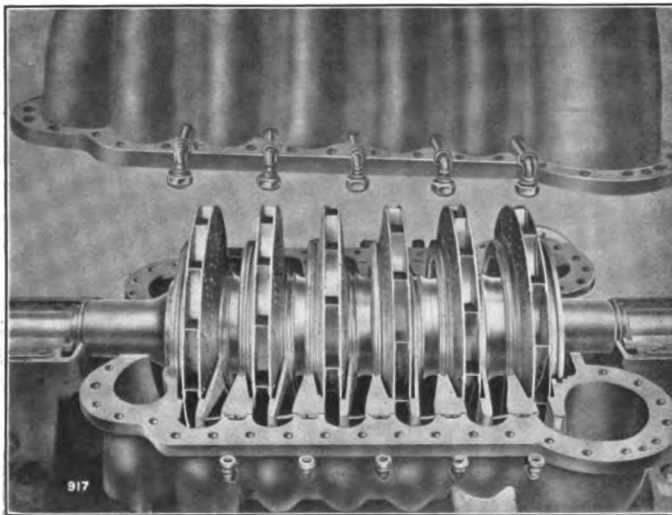

Six-Stage Compressor with Top Casing Removed

sultant thrust equal to the area of the suction opening multiplied by the pressure generated. The accumulated thrust of all the stages is overcome by a balancing disk at the discharge end, so arranged that one side receives the total discharge pressure in a direction opposite to that acting upon the impeller disk, while the chamber upon the opposite side of the balancing disk is connected to the suction inlet, thus completely neutralizing the unbalanced pressure on all of the wheels.

As in the case of single-stage blowers, the head-delivery characteristic can be varied considerably to meet different requirements. Generally where compressed air is used in tools, a fairly constant pressure over a wide range of delivery is desired. The capacities in such cases range between 2,000 and 10,000 cu. ft. per min., and the pressures from 75 to 120 lb. per sq. in. Less

the enclosure when blasting is going on. The exhaust fan is double and is driven by a 35-hp. motor running at 870 r. p. m. The dust-laden air is exhausted into a dry process screen type

units, one on either side of the car so that both sides can be cleaned at once. The sand separators and the elevators are driven by 5-hp. electric motors running at 850 r. p. m. Cars

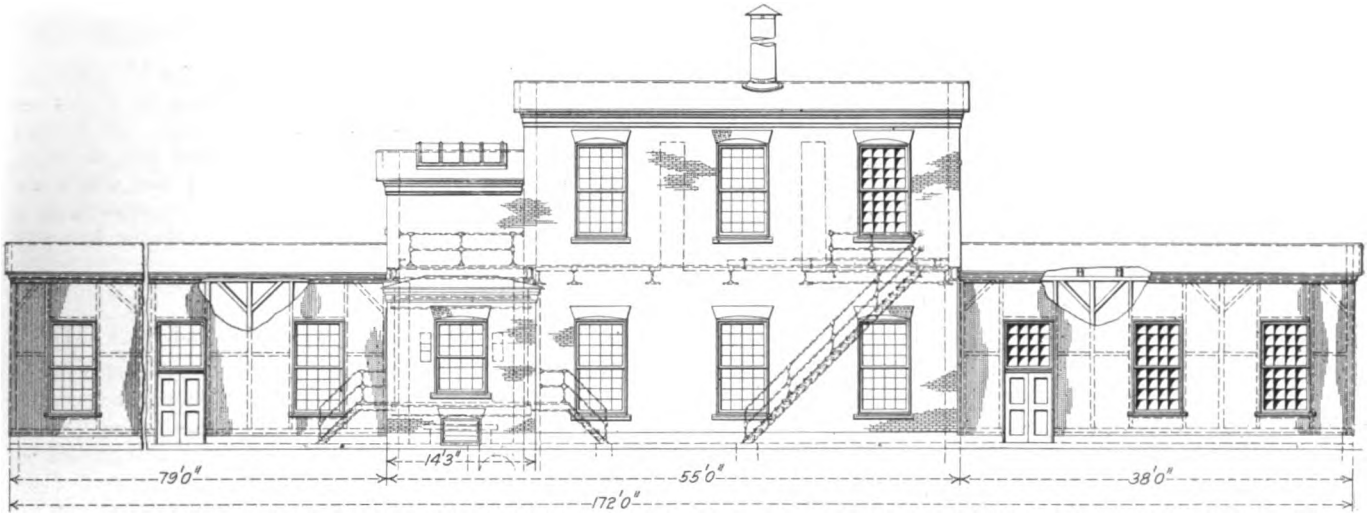

Side Elevation of the Building for Sand Blasting Steel Cars

dust arrester where the dust is completely separated. The dust is then delivered to dust boxes located on the first floor. The elevating, separating and blasting machinery is in two

are hauled in and out of the building by an electric winch, built by the American Engineering Company, Philadelphia, Pa., and having a capacity of 6,000 lb. at a speed of 50 ft. per minute.

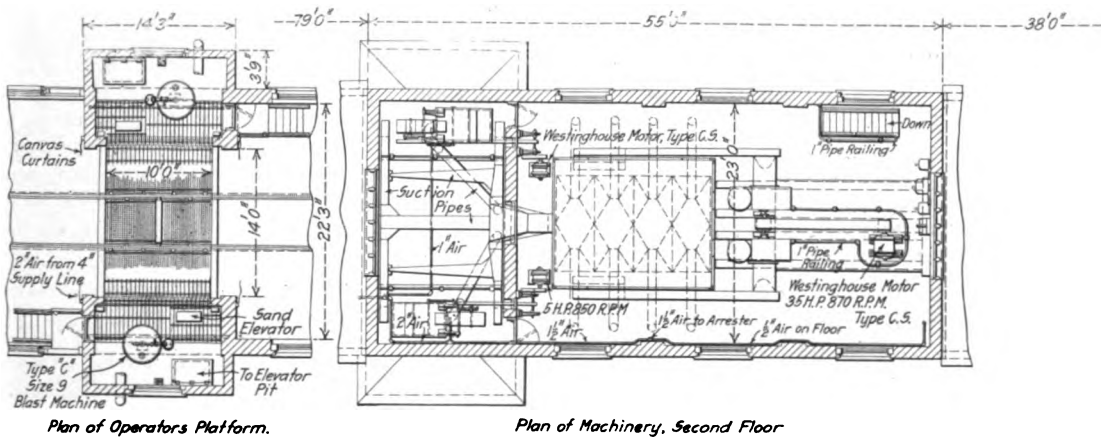

Plan of Operators Platform.

Plan of Machinery, Second Floor

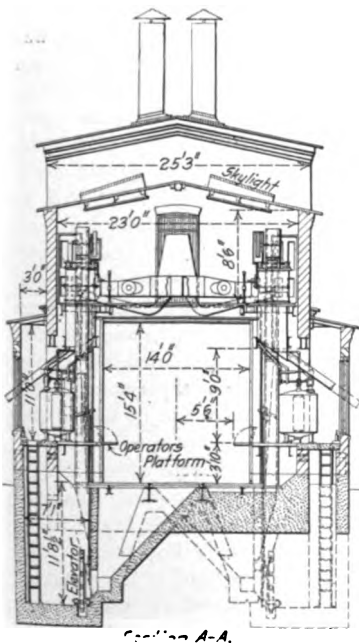

Section A-A.

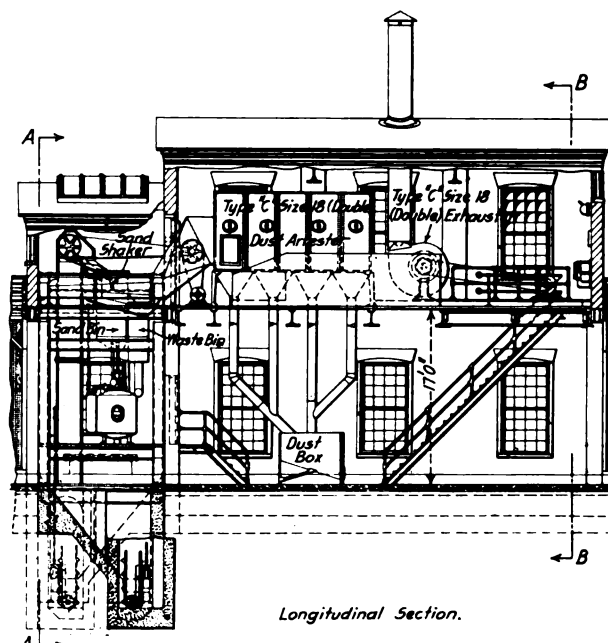

Longitudinal Section.

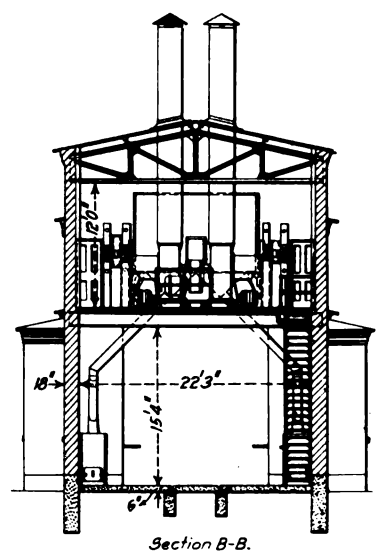

Section B-B.

Sectional View Showing the Arrangement of the Machinery for Cleaning Steel Cars by Sand Blasting

NEWS DEPARTMENT

The Brotherhood of Locomotive Engineers, at a convention recently held in Cleveland, adopted a resolution advocating a federal law requiring high-power headlights on locomotives on all steam railroads in the country.

The Pennsylvania Railroad has received word from the Panama-Pacific International Exposition at San Francisco that the company has been awarded the grand prize, the highest honor which could be conferred upon any railroad exhibiting.

The "Sunset-Central Boys' Educational Association" has been formed by officers of the Sunset Central Lines at Houston, Tex., for the purpose of organizing classes of office boys and messengers to study penmanship, arithmetic, typewriting and shorthand. Similar educational advantages are to be afforded to the young women employed by the company, of whom there are about 250 in Houston.

In the federal court at Jackson, Miss., June 15, a temporary injunction was granted restraining all district attorneys in Mississippi from prosecuting the Illinois Central and the Yazoo & Mississippi Valley for violating a headlight law passed by the legislature in 1912. The law stipulates that all locomotives operating on main lines in the state shall be equipped with high-power headlights. The case will be argued this month, when the roads will seek a permanent injunction.

The railroad department of the Young Men's Christian Association is establishing a railroad school in its recently completed college for the training of secretaries at Chicago. This course will be under the direction of leading railroad Y. M. C. A. secretaries, with W. N. Northcott, executive secretary of the railroad associations of Chicago, as dean. The purpose of the course is to train men to become efficient secretaries of railroad branches. This department of the school will begin its work next October.

Among the employees of the Pennsylvania Railroad retired on pension May 1 last was William Watson, staybolt inspector in the shops at Altoona, who had been in the service of the company 34 years and for over 20 years was inspector of flues in locomotives. A portrait of Mr. Watson is given in the bulletin issued by the company, and it is calculated that during his twenty years of service in this occupation he had crawled through the fire doors of 20,000 locomotives, and had inspected 6,440,000 flues.

A pamphlet entitled *Railway Sanitation* has been printed by the Baltimore & Ohio for circulation among employees in all departments of the service, for the general benefit. It consists of five articles on the subject by Dr. E. M. Parlett, re-printed from the *Baltimore & Ohio Employees' Magazine*. Dr. Parlett is a member of the General Safety Committee of the road. These essays include one dealing in detail with the sanitation of construction camps, and another on typhoid fever and its conquest.

The poem published on page 1377 of the *Daily Railway Age Gazette* of June 16, entitled "The Lament of the Foreign Bad Order Empty Car," which was ready by Secretary Taylor at the Master Car Builders' convention at Atlantic City as anonymous, was written by E. E. Betts, superintendent of transportation of the Chicago & North Western, and included by him in a series of bulletins issued to the members of the Chicago General Superintendents' Association by the committee on the Promotion of the Proper Handling of Equipment, of which Mr. Betts is chairman, for the purpose of calling attention to some of the methods in vogue for handling bad order cars. Mr.

Betts says he is not so anxious about credit for his authorship as he is that somebody shall pay some attention to it. "It was reported as an amusing communication," he says, "all of which may be true. At the same time it was hoped that the moral would sink into some of our head mechanical men who would be aroused as to the necessity of taking some action to put a stop to the wanderings of the aforesaid foreign bad order empty cars."

SAFETY FIRST WORK ON THE NORFOLK & WESTERN

C. H. Blakemore, chairman of the safety commission of the Norfolk & Western, has issued a bulletin showing the decrease in injuries to employees during the 20 months ending December 31, 1914, since the safety movement was inaugurated on this road. The improvement with relation to the number of employees is shown on a chart on which is plotted a line showing the number of injuries and a line showing the fluctuations in the pay roll. The total pay roll and the total number of injuries as of May, 1913, is taken as a base line for making comparisons, and with relation to this line from August 1913 (the high point, with 463 accidents), to December, 1914, with 172 accidents, there was a decline of 70 per cent. From May, 1913, the lines showing pay roll and injuries gradually diverge and at the end of 1913 the pay roll had declined 7 per cent, while accidents had gone down 25 per cent. At the end of 1914 the pay roll had declined to 17 per cent below the base line, while accidents had gone down 58 per cent, a further gain in accident reduction of 41 per cent. When the safety movement was inaugurated one employee on the line was being injured for each \$3,600 of pay roll. For December, 1914, one employee was injured for each \$7,000 of pay roll.

CAUSE OF OAKWOOD (WIS.) DERAILMENT

The Interstate Commerce Commission has issued a report, dated April 28, on the derailment of a passenger train on the Chicago, Milwaukee & St. Paul at Oakwood, Wis., January 30, when 21 passengers were injured. The train was derailed at a crossover when running about 55 miles an hour, and Inspector H. W. Belpap concludes that the cause of the derailment was the breaking of a steel tired wheel on the middle of the right-hand side of a six-wheel truck at the front end of the baggage car. The wheel was of a built-up type with a cast iron spider, two rolled steel cheek plates and a rolled steel tire. The parts were held together by 39 bolts. The tire broke into four pieces and it was found that ruptures through the bolt holes had started, in each case, at the inner diameter of the tire, thence passing through the metal in an outward direction to the surface of the tire and through the flange. Considerable wear was found at the bearing between the plate and the tire. The mate of the broken wheel was taken apart and in it were found incipient cracks at each of the twelve bolt holes in the tire; and similar incipient cracks were found in other wheels examined. None of these cracks were visible until the outer circle of bolts was taken out or one of the plates removed. The broken wheel had not been overloaded. It had run 276,396 miles. The study of the broken wheel, and of others of the same type, was made by J. E. Howard, engineer. He concludes that tires of this type are sometimes loose, while yet the looseness is not detected by the ordinary inspections. His principal recommendation is for better inspection of the metal at the bolt holes, which means, of course, that wheels would have to be taken apart, as the cracks above referred to cannot be seen in an ordinary inspection.

MEETINGS AND CONVENTIONS

Master Car and Locomotive Painters' Association.—The forty-sixth annual convention of the Master Car and Locomotive Painters' Association will be held at the Hotel Statler, Detroit, Mich., September 14, 15, 16 and 17. The following subjects will be considered: Flat Color vs. Enamel Color; Effect of Steel Passenger Car Design on Protective Coating; Finish of Enamel or Varnish Color Compared with Varnish Finish; Piece Work; Maintenance of Inside of Steel Passenger Cars; Results of Price vs. Quality in Buying Paint Material.

International Railway General Foremen's Association.—The eleventh annual convention of the International Railway General Foremen's Association will be held at the Sherman Hotel, Chicago, July 13-16, 1915. Reports will be presented on the following subjects: Valves and Valve Gears, chairman, Walter Smith, Chicago & North Western; Rods, Ties, Wheels, Axles and Crank Pins, chairman, A. A. Masters, Delaware & Hudson; Shop Efficiency, chairman, George H. Logan, Chicago & North Western; Oxy-Acetylene Welding, chairman, F. A. Byers, St. Louis & San Francisco. A paper on the operation of a large engine terminal will be read by N. A. Whitsel, Chicago & Western Indiana. Shop and roundhouse foremen are urged to attend the convention and take part in the discussion.

American Railway Tool Foremen's Association.—At the annual convention of the American Railway Tool Foremen's Association which will be held at the Hotel Sherman, Chicago, July 19-21, 1915, the following topics will be discussed: Special Jigs and Devices in Locomotive Repair Shops; Safety First in Regard to Machinery and Tools; Special Tools and Equipment for Maintenance of Pneumatic Tools; Grinding and Distribution of Machine Tools in Locomotive Repair Shops, and Standardization of Reamers for Locomotive Repair Shops. This subject, which was taken up at the last convention, has been continued and each member of the association is requested to report on it at the coming convention. The selection of an emblem for the association will also be considered.

The following list gives names of secretaries, dates of next or regular meetings, and places of meeting of mechanical associations.

- AIR BRAKE ASSOCIATION.**—F. M. Nellis, 53 State St., Boston, Mass.
- AMERICAN RAILROAD MASTER TINNERS, COPPERSMITHS AND PIPEFITTERS' ASSOCIATION.**—W. E. Jones, C. & N. W., 3814 Fulton street, Chicago. Annual meeting, July 13-16, 1915, Hotel Sherman, Chicago.
- AMERICAN RAILWAY MASTER MECHANICS' ASSOCIATION.**—J. W. Taylor, Karpen building, Chicago.
- AMERICAN RAILWAY TOOL FOREMEN'S ASSOCIATION.**—Owen D. Kinsey, Illinois Central, Chicago. Convention, July 19-21, 1915, Hotel Sherman, Chicago.
- AMERICAN SOCIETY FOR TESTING MATERIALS.**—Prof. E. Marburg, University of Pennsylvania, Philadelphia, Pa.
- AMERICAN SOCIETY OF MECHANICAL ENGINEERS.**—Calvin W. Rice, 29 W. Thirty-ninth street, New York. Annual meeting, December 7-10, 1915, New York.
- ASSOCIATION OF RAILWAY ELECTRICAL ENGINEERS.**—Joseph A. Andreucetti, C. & N. W., Room 411, C. & N. W. Sta., Chicago. Annual meeting, October, 1915.
- CAR FOREMEN'S ASSOCIATION OF CHICAGO.**—Aaron Kline, 841 North Fifthth Court, Chicago; 2d Monday in month, except July and August, Lytton building, Chicago.
- CHIEF INTERCHANGE CAR INSPECTORS' AND CAR FOREMEN'S ASSOCIATION.**—S. Skidmore, 946 Richmond street, Cincinnati, Ohio. Annual meeting, September 14-16, 1915, Richmond, Va.
- INTERNATIONAL RAILWAY FUEL ASSOCIATION.**—C. G. Hall, 922 McCormick building, Chicago.
- INTERNATIONAL RAILWAY GENERAL FOREMEN'S ASSOCIATION.**—William Hall, 1126 W. Broadway, Winona, Minn. Convention, July 13-16, 1915, Hotel Sherman, Chicago.
- INTERNATIONAL RAILROAD MASTER BLACKSMITHS' ASSOCIATION.**—A. L. Woodworth, Lima, Ohio. Convention, August 17, 1915, Philadelphia, Pa.
- MASTER BOILER MAKERS' ASSOCIATION.**—Harry D. Vought, 95 Liberty street, New York.
- MASTER CAR BUILDERS' ASSOCIATION.**—J. W. Taylor, Karpen building, Chicago.
- MASTER CAR AND LOCOMOTIVE PAINTERS' ASSOC. OF U. S. AND CANADA.**—A. P. Dane, B. & M., Reading, Mass. Convention, September 14-17, 1915, Detroit, Mich.
- NIAGARA FRONTIER CAR MEN'S ASSOCIATION.**—E. Frankenberger, 623 Brisbane building, Buffalo, N. Y. Meetings monthly.
- RAILWAY STOREKEEPERS' ASSOCIATION.**—J. P. Murphy, Box C, Collinwood, Ohio.
- TRAVELING ENGINEERS' ASSOCIATION.**—W. O. Thompson, N. Y. C. & H. R., East Buffalo, N. Y. Convention, September 7-10, 1915, Hotel Sherman, Chicago, Ill.

PERSONALS

It is our desire to make these columns cover as completely as possible all the changes that take place in the mechanical departments of the railways of this country, and we shall greatly appreciate any assistance that our readers may give us in helping to bring this about.

GENERAL

W. M. BOSWORTH, mechanical engineer of the Louisville & Nashville, has been appointed mechanical engineer of the Norfolk Southern, with headquarters at Berkley, Va.

E. B. DE VILBIS, electrical engineer of the Pennsylvania Lines West, at Fort Wayne, Ind., has been appointed assistant engineer of motive power, with headquarters at Toledo, Ohio.

G. W. GOOD, formerly supervisor of piece work, New York Central, Lines West of Buffalo, has been appointed special representative, reporting to the general manager of the Michigan Central, with headquarters at Detroit. He will have entire charge of piece work in all departments, and will pass upon requests for new machinery.

B. B. MILNER has been appointed engineer of motive power of the New York Central, in charge of locomotive design and construction, and the relation of locomotive standards to operation, with headquarters at New York.

O. P. REESE, master mechanic of the Pennsylvania Lines West, with headquarters at Crestline, Ohio, and Pittsburgh, Pa., has been appointed assistant engineer of motive power, in the office of the general superintendent of motive power, succeeding T. R. Cook, resigned.

MASTER MECHANICS AND ROAD FOREMEN OF ENGINES

F. F. CAREY, formerly a locomotive engineman of the Intercolonial Railway, has been appointed acting district master mechanic, District 3, at Moncton, N. B.

C. CONNORS has been appointed district master mechanic of district No. 1, Ontario division of the Canadian Pacific, at Toronto, Ont.

G. I. EVANS has been appointed district master mechanic, Ontario division of the Canadian Pacific, at Toronto, Ont.

J. W. FINDLAY has been appointed master mechanic of the Toronto division of the Canadian Northern at Parry Sound, Ont.

L. A. HARDIN, general foreman of the Chicago & North Western at Boone, Iowa, has been appointed assistant master mechanic at South Pekin, Ill.

A. H. MAHAN, locomotive foreman of the Grand Trunk Pacific at Prince George, B. C., has been appointed general locomotive foreman, with jurisdiction over territory from Prince George to Edmonton, Alta., including intervening branch lines.

J. F. MOFFATT, road foreman of engines of the Grand Trunk Pacific, with headquarters at Wainwright, Alta., has been appointed general locomotive foreman, with jurisdiction over territory from Transcona, Man., to Fort William, Ont., inclusive.

W. C. MOORE, formerly road foreman of engines of the Canadian Northern, has been appointed master mechanic of the Ottawa division at Trenton, Ont.

W. G. MCCONACHIE, road foreman of engines of the Grand Trunk Pacific, with headquarters at Edmonton, Alta., has been appointed general locomotive foreman, with jurisdiction over territory from Edmonton, Alta., to Watrous, Sask., including intervening branch lines.

M. B. MCPARTLAND has been appointed master mechanic of the Colorado and Nebraska divisions of the Chicago, Rock Island

& Pacific, with headquarters at Goodland, Kan., succeeding E. F. Tegtmeier, resigned.

H. G. RIED has been appointed master mechanic of the Saskatchewan division of the Canadian Pacific at Moose Jaw, Sask., succeeding M. J. Scott, transferred.

M. J. SCOTT has been appointed master mechanic of the Alberta division of the Canadian Pacific at Calgary, Alberta, succeeding A. Sturrock, transferred.

H. R. SIMPSON, road foreman of engines of the Grand Trunk Pacific, with headquarters at Jasper, Alta., has been appointed general locomotive foreman, with jurisdiction over territory from Watrous, Sask., to Winnipeg, Man., including intervening branch lines.

W. H. KELLER, who has recently been appointed master mechanic of the Baltimore & Ohio Southwestern at Cincinnati, Ohio, began railroad work on the Baltimore & Ohio as engine wiper in 1886. In the following year he became machinist apprentice on the Baltimore & Ohio at Keyser, W. Va., serving four years. He served as machinist at Keyser, at Cumberland, Md., and Grafton, W. Va., from 1891 to 1897. In that year he was appointed foreman at Jayenn, W. Va., and was later foreman at Wiston, W. Va., general foreman at Fairmont, W. Va., and later general foreman at Storrs. In 1912 he was transferred as general foreman from Storrs to Flora, Ill., and in 1914 was appointed division foreman of the Cincinnati, Hamilton & Dayton at Dayton, Ohio. In April, 1914, he was made acting master mechanic of the Cincinnati, Hamilton & Dayton at Indianapolis, and in February, 1915, was made assistant master mechanic at Cincinnati, which position he held when appointed master mechanic of the Indianapolis division of the Baltimore & Ohio Southwestern.



W. H. Keller

G. E. SISCO, who has been appointed master mechanic of the Toledo and Marietta divisions of the Central system of the Pennsylvania Lines West, began railway work in June, 1901, at the Fort Wayne shops of the Pennsylvania, Fort Wayne, Ind. At the end of the summer he returned to Johns Hopkins University, graduating in 1902, and again went to the Fort Wayne shops, this time as special apprentice. He was made foreman in 1906, and in September of the same year was transferred as foreman to the Allegheny shops. In June, 1910, he was appointed assistant master mechanic at the Allegheny shops. In January, 1912, he was made assistant engineer of motive power of the Southwestern system of the Pennsylvania Lines, with office at Columbus, Ohio, holding this position until his appointment as master mechanic.

A. STURROCK has been appointed master mechanic of the British Columbia division of the Canadian Pacific at Vancouver, B. C., succeeding D. T. Main, promoted.

A. WATT, general foreman of the Grand Trunk Pacific at Prince Rupert, B. C., has been appointed general locomotive foreman, with jurisdiction over territory from Prince Rupert to Prince George, B. C.

FRANK W. WILMORE has been appointed assistant road foreman of engines of the Pennsylvania Lines West of Pittsburgh, with headquarters at Fort Wayne, Ind., succeeding Robert J. Lyons, assigned to other duties at his own request.

CAR DEPARTMENT

P. ALQUIST, superintendent of the car department of the Missouri, Kansas & Texas at Sedalia, Mo., has been appointed general superintendent of the car department, with headquarters at Dennison, Tex.

W. FORREST has been appointed car foreman of the Canadian Pacific at Megantic, Que.

W. H. LONG, formerly general car foreman of the Canadian Northern at Toronto, Ont., has been appointed division car foreman of the Ottawa division at Trenton, Ont.

W. F. MILLER has been appointed division car foreman of the Toronto division of the Canadian Northern at Parry Sound, Ont.

WILLIAM WALKER, general foreman of the Sedalia shops of the Missouri, Kansas & Texas, has been appointed superintendent of the car department at Sedalia, Mo., succeeding P. Alquist, promoted.

SHOP AND ENGINE HOUSE

W. H. ARCHER has been appointed locomotive foreman of the Grand Trunk at Palmerston, Ont., succeeding J. A. Walton, transferred.

ROY W. BAND, formerly superintendent of shops of the Boston & Maine at Concord, N. H., has been appointed general mechanical shop inspector at Boston, Mass., and will report to the superintendent of motive power.

D. W. HAY has been appointed locomotive foreman of the Grand Trunk Pacific at Prince George, B. C., succeeding A. H. Mahan, promoted.

J. A. MILLER has been appointed locomotive foreman of the Grand Trunk Pacific at Endako, B. C., succeeding G. H. Laycock, transferred to Jasper, Alta.

PURCHASING AND STOREKEEPING

C. D. FRENCH has been appointed storekeeper of the Canadian Northern at Humboldt, Sask., succeeding S. K. Moorcroft, promoted.

A. E. HUTCHINSON has been appointed general purchasing agent of the Oregon Short Line, with headquarters at Salt Lake City, Utah, succeeding G. H. Robinson.

S. K. MOORCROFT has been appointed division storekeeper of the Canadian Northern at Saskatoon, Sask., succeeding A. E. Down, resigned to enter military service in Europe.

G. H. ROBINSON has been appointed general storekeeper of the Oregon Short Line at Pocatello, Idaho, succeeding T. A. Martin, promoted.

OBITUARY

CHARLES HAYWARD, formerly purchasing agent of the Chicago & North Western, died in Chicago, on June 13, at the age of 77 years. Mr. Hayward was born on October 15, 1837, entered railway service in 1879 with the Chicago & North Western, and was purchasing agent for many years.

M. E. SHERWOOD, division master mechanic of the Michigan Central, at Jackson, Mich., was accidentally shot and killed at that place on June 4. He was 46 years of age.

N. A. WALDRON, general storekeeper of the Missouri, Kansas & Texas, with headquarters at Parsons, Kan., died in St. Louis, Mo., on May 30.

SUPPLY TRADE NOTES

F. W. McIntyre, for the past four years connected with the Chicago office of the Niles-Bement-Pond Company, has been transferred to the Boston office, where he was formerly located.

George C. Wilson, of the Independent Pneumatic Tool Company, Chicago, has been appointed manager of that company's branch at Atlanta, Ga., succeeding F. H. Charbono, who has been transferred to Boston.

The Safety Car Heating & Lighting Company, New York, has been awarded a gold medal by the International Jury of Awards at the Panama Pacific International Exposition for its "Underframe" car lighting electric equipment.

C. H. Morse, Jr., has been elected president of Fairbanks, Morse & Company, succeeding his father, C. H. Morse, Sr. He is 41 years and was graduated from the University of



C. H. Morse, Jr.

Michigan in 1895, as a mechanical engineer. He first entered one of the Fairbanks, Morse & Company shops in order to get a practical knowledge of the building of gas engines, pumps, etc. He has been president of the Fairbanks, Morse Manufacturing Company, Beloit, Wis., in charge of manufacturing, for ten years, which position he still holds. He has also been a director of Fairbanks, Morse & Company, Chicago, for 15 years, a director of Fairbanks, Morse Electrical Manufacturing Company, Indianapolis, Ind., for eight years. Eight

years ago Mr. Morse was also elected a director of the Canadian Fairbanks, Morse Company. C. H. Morse, Sr., the retiring president of Fairbanks, Morse & Company, was born in St. Johnsbury, Vt., in September, 1833. He began his business career at the age of 17, when he became clerk in the office of E. & F. Fairbanks & Co., scale manufacturers. In 1862 he became a member of the firm of Fairbanks, Greenleaf & Co., successors to E. & F. Fairbanks & Co. In 1872 the firm of Fairbanks, Morse & Co. was established, Mr. Morse, Sr., being elected president, which position he held until May '9, when he resigned.

R. M. Newbold, formerly with the Adams & Westlake Company, has been appointed western manager of the railroad department of the Willard Storage Battery Company, succeeding P. D. Smith, who has resigned to accept service with another company.

The Kincaid Stoker Company, Cincinnati, Ohio, has been incorporated, with \$50,000 capital stock, to manufacture mechanical stokers for use on locomotives, ships and in power plants. John Kincaid, Napoleon DuBrul, D. S. DuBrul and Clarence DuBrul are the incorporators.

Richard S. Brown, formerly a salesman of railway apparatus, connected with the Boston office of the Westinghouse Electric & Manufacturing Company, died in New York June 5. Mr. Brown was 76 years of age and had been in the service of the Westinghouse company since 1890.

H. C. Crawford, eastern traffic manager of the Cambria Steel Company at Philadelphia, has been appointed traffic manager of

that company, succeeding William A. Sproul, who has resigned, effective August 1, after 25 years of service with the company, to take charge of the bureau of transportation and traffic of the Philadelphia Chamber of Commerce.

H. M. Montgomery has been elected vice-president and a director of the Powdered Coal Engineering & Equipment Company, Chicago. This company is preparing elaborate plans for the construction and equipment of a plant and research laboratory in Chicago, where working demonstrations of the adaptation of powdered coal as a fuel to all forms of heat production will be carried on, including its adaptability to locomotive service.

The Ingersoll-Rand Company, New York, on June 1 opened a new branch office at 139 Townsend street, San Francisco, Cal., with a view to giving closer attention to the needs of present and prospective users of Ingersoll-Rand machinery. H. L. Terwilliger, president of Harron, Rickard & McCone, the present Ingersoll-Rand agents, has resigned from that position to become district manager of the territory handled by the Ingersoll-Rand Company's San Francisco and Los Angeles offices, with headquarters in the former city. H. G. Mitchell, formerly secretary of Harron, Rickard & McCone, has been elected president of that company, succeeding Mr. Terwilliger, and arrangements have been made whereby the company will continue to handle Ingersoll-Rand machinery and co-operate in other ways with the Ingersoll-Rand Company after the expiration of the agency contract on July 22.

Harrison G. Thompson, a vice-president, and manager of the railway department of the Edison Storage Battery Company, Orange, N. J., has been appointed general sales manager and



H. G. Thompson

as such will have charge of all sales including the railway, house lighting and commercial departments. Mr. Thompson has been in the service of the Edison Storage Battery Company since July, 1910, becoming a vice-president in July, 1913. He was born at Weston, Mass., in 1875. In 1896 he entered the service of the Pullman Company and after having been with that company for two years was made foreman of electricians. In 1900 he resigned to become foreman of the battery department of the Riker Motor Vehicle Company,

but left the latter at the time of its absorption by the General Vehicle Company of Hartford, Conn., to become associated with W. L. Bliss, one of the pioneers in electric car lighting development. In 1905 he entered the service of the Pennsylvania Railroad and was placed in charge of electric car lighting with headquarters at Jersey City, N. J. About one year later he became electrical superintendent of the Safety Car Heating & Lighting Company, New York, and was in charge of that company's electrical laboratories during the development of its first electric car lighting system. In December, 1909, he was appointed manager of the railroad department of the Westinghouse Storage Battery Company and later for a short time was in the employ of the United States Light & Heating Company, New York. In July, 1910, he became manager of the railway department of the Edison Storage Battery Company.

The Chambers Valve Company, New York, announces that among other recent orders, it has received orders for Chambers throttle valves for installation on 42 locomotives of the Missouri, Kansas & Texas, 55 of the Chicago, Burlington & Quincy, 15 of the Western Maryland, 12 of the New York, Ontario & Western, and 2 of the El Paso & Southwestern.

The Harvey Company, 113 South street, Baltimore, Md., has recently been incorporated under the laws of Maryland to sell equipment and supplies to railroads, contractors, shop and engine building companies, etc. J. Edward Harvey, who has been elected president of the new company, was formerly vice-president of the South Baltimore Steel Car & Foundry Company, Baltimore, Md., and at one time proprietor of the Eastern Railway Supply Company.

Merton A. Peacock has been appointed district sales manager of the Terry Steam Turbine Company, Hartford, Conn., for the territory included in Minnesota, North Dakota and South Dakota, with office at 400 Endicott building, St. Paul, Minn. This arrangement supersedes the previous selling agreement with the Robinson, Cary & Sands Company, St. Paul. The company has also appointed the Hawkins-Hamilton Company, Peoples National Bank building, Lynchburg, Va., as its representatives for Virginia.

Benton C. Rowell, an inventor of numerous mechanical devices for use in railroad operation, and one of the most prominent advocates of automatic train control, died suddenly of heart failure on May 29 at Chicago, aged 58 years. He had made practically a life study of automatic train control. In 1891 he demonstrated his safety stop on the Boston, Revere Beach & Lynn, and in 1893 on the Intramural Railway at the Chicago World's Fair. In 1893 and 1894 the device was installed on the Chicago South Side Elevated Railroad, and in 1894 and 1895 on the Metropolitan West Side Elevated Railroad at Chicago. It was also given a service test on the Chicago, Burlington & Quincy in 1908 and 1909. Mr. Rowell also had numerous patents pending on appliances connected with railroad signaling.

The business of the Wells Light Manufacturing Company, Jersey City, N. J., has been acquired by the Alexander Milburn Company, Baltimore, Md., manufacturers of high power portable lights and oxy-acetylene welding apparatus. Repair parts for Wells lights will be manufactured and supplied in the future by the Alexander Milburn Company from its Baltimore factory, and complete Wells oil lights will also be furnished where desired, in conjunction with the standard Milburn acetylene lights. The manufacture of Wells oil preheating burner outfits will be continued by the company and sold in connection with Milburn oxy-acetylene apparatus. The Wells lights and Wells preheating devices have been on the market for about 20 years, and have occupied a leading place among oil-burning equipment of their kind.

Guy E. Tripp, chairman of the Westinghouse Electric & Manufacturing Company, has been quoted as follows: "The Westinghouse Electric & Manufacturing Company has purchased the property and assets of the Stevens Arms & Tool Company and the Stevens-Duryea Automobile Company, and a company has been incorporated under the laws of Massachusetts to own and control these two properties. This company will be known as the New England Westinghouse Company, and all of its \$2,000,000 capital stock is owned by the Westinghouse Electric & Manufacturing Company. The company has no bonded debt. These two companies were purchased by the Westinghouse as a result of the order for 1,000,000 rifles which we have taken from the Russian government. This large order will be filled entirely from the two Stevens companies that have been purchased. It is not the intention of the Westinghouse Electric & Manufacturing Company to make any alterations whatever to its present plants in connection with this rifle order. In other words, it is to be filled by companies which are thoroughly experienced in the manufacture of this class of product, so that there are few uncertainties in connection with the transaction."

CATALOGS

HEADLIGHTS.—The Esterline Company, Indianapolis, Ind., has recently issued catalog 364 descriptive of Golden Glow incandescent headlights. These headlights are extensively used on street car and interurban railway lines, and are also built for both steam and electric locomotive service.

OXYGEN BY WATER ELECTROLYSIS.—In a pamphlet entitled "Production of Pure Oxygen and Hydrogen," the International Oxygen Company of Newark, N. J., gives a description of its system of producing oxygen by water electrolysis. Several installations of this system are illustrated. The purity of the gases produced by this method is shown to be especially high.

BOILER WATER TREATMENT.—The Bird-Archer Company, 90 West street, New York, has recently issued a 40-page pamphlet dealing with boiler maintenance and discussing its system of polarized metallic boiler chemicals for locomotive use. A portion of the book is devoted to a brief treatise on locomotive boiler maintenance prepared by a general boiler inspector.

INSULATORS.—In a recently issued 12-page pamphlet the Brookfield Glass Company, 2 Rector street, New York, gives a brief list of insulators and insulator pins forming a part of its line of these products. Complete dimensions and specifications are given for each item. A more extensive list of the products of this company is contained in its bulletin No. 56.

LOCOMOTIVE CRANES.—The Ohio Locomotive Crane Company, Bucyrus, Ohio, has issued a 56-page catalog in which the construction of its line of locomotive cranes is set forth in detail. The catalog contains a large number of illustrations of detail parts as well as reproductions from a number of photographs showing cranes in service. Clearance diagrams of various types of cranes are also given.

DRIVING BOX LUBRICATOR.—A catalog just issued by the Franklin Railway Supply Company, New York, is devoted to the Franklin automatic driving box lubricator. It is illustrated with a large number of sectional drawings showing the construction of lubricators of various sizes and for different classes of service. The method of removing packing and replacing the cellar is clearly explained with illustrations.

RUSTPROOFING.—In the April number of the Scientist, published by the Goheen Manufacturing Company, Canton, Ohio, considerable information is given regarding the waterproofing of concrete and the protection of steel and galvanized iron from rust. Records are given of a number of bridges on the Chicago, Milwaukee & St. Paul to which the carbonizing coating manufactured by this company has been applied.

WATER METERS.—The Harrison Safety Boiler Works, Philadelphia, Pa., has issued engineering leaflet No. 18, dealing with the Cochrane V-notch weir, used in the Cochrane metering heater. This pamphlet is a reprint of two papers on the V-notch weir, showing the refinements essential to accuracy in investigating problems in hydraulics and the constancy of the V-notch weir when used under known conditions.

LOCOMOTIVES.—The H. K. Porter Company, Pittsburgh, Pa., has recently issued the eleventh edition of its catalog devoted to steam locomotives. This is a book of over 150 pages, 8½ in. by 11 in., and is substantially bound in cloth. In addition to the usual catalog features dealing with a large variety of standard Porter locomotives, it contains a section devoted entirely to engineering information, tables and formulas, and another section containing tables and other useful information not usually found in print. The book is intended especially for engineers, superintendents and master mechanics of industrial plants, coal mines, logging roads, etc. Owing to the expense involved in the compilation of the data which the book contains, general distribution is being made at the price of \$1 per copy.

Railway Age Gazette

MECHANICAL EDITION
INCLUDING THE
AMERICAN ENGINEER

PUBLISHED ON THE FIRST THURSDAY OF EVERY MONTH BY THE
SIMMONS-BOARDMAN PUBLISHING COMPANY
WOOLWORTH BUILDING, NEW YORK, N. Y.

CHICAGO: Transportation Bldg. CLEVELAND: Citizens' Bldg.
LONDON: Queen Anne's Chambers, Westminster.

EDWARD A. SIMMONS, *President* L. B. SHERMAN, *Vice-President*
HENRY LEE, *Secretary-Treasurer*
The address of the company is the address of the officers

ROY V. WRIGHT, *Editor*

R. E. THAYER, *Associate Editor* A. C. LOUDON, *Associate Editor*
C. B. PECK, *Associate Editor*

Subscriptions, including the eight daily editions of the *Railway Age Gazette* published in June in connection with the annual conventions of the Master Car Builders' and American Railway Master Mechanics' Associations, payable in advance and postage free:

United States, Canada and Mexico..... \$2.00 a year
Foreign Countries (excepting daily editions). 3.00
Single Copy 20 cents

Entered at the Post Office at New York, N. Y., as mail matter of the second class.

WE GUARANTEE that of this issue 6,000 copies were printed; that of these 6,000 copies 5,000 were mailed to regular paid subscribers, 155 were provided for counter and news companies' sales, 294 were mailed to advertisers' exchanges and correspondents, and 641 were provided for new subscriptions, samples, copies lost in the mail and office use; that the total copies printed this year to date were 45,000, an average of 5,725 copies a month.

THE RAILWAY AGE GAZETTE, MECHANICAL EDITION, and all other Simmons-Boardman publications are members of the Audit Bureau of Circulations.

VOLUME 89 AUGUST, 1915 NUMBER 8

CONTENTS

EDITORIALS:	
Ten Dollars for a Good Letter.....	383
Safety First in Railway Shops.....	383
The July Conventions.....	383
A Car Department Competition.....	384
The Supplyman at Conventions.....	384
Consolidation of Mechanical Associations.....	384
Sufficient and Competent Supervision.....	384
Prevention of Engine Failures.....	385
New Books.....	385
COMMUNICATIONS:	
Laying Out the Southern Valve Gear.....	386
GENERAL:	
How Do You Select Your Men?.....	387
Reciprocating and Revolving Parts.....	390
Characteristics of Plate Springs.....	392
Examples of Recent Locomotives.....	396
CAR DEPARTMENT:	
Well Car of 200,000 lb. Capacity.....	397
Testing Car Roofs.....	399
All-Steel Box Car.....	399
Long Island Steel Suburban Cars.....	402
Inspection and Maintenance of Air Brakes on Freight Cars.....	406
SHOP PRACTICE:	
Oil Burning Sand Dryer.....	407
Manufacturing Brooms.....	407
Oiling Air Pump Air Cylinders.....	408
Tool Foremen's Association.....	409
Relief Valve for Superheater Locomotives.....	416
General Foremen's Convention.....	417
NEW DEVICES:	
Plant for Sand Blasting Steel Cars.....	427
Small Steam Driven Air Compressor Unit.....	428
Lever Hand Brake.....	428
Pipe Threading and Cutting Machine.....	429
Rolled Steel Truck Frames.....	429
Extensible Vestibule Trap Door.....	430
Brake Beam Safety Hanger.....	431
Simple Coupler Release Rigging.....	431
Hulson Locomotive Grate.....	431
Emergency Jack with Adjustable Base.....	432
National Hose Coupling.....	432
Recorder for Measuring Flow Over Weirs.....	433
NEWS DEPARTMENT:	
Notes.....	434
Meetings and Conventions.....	434
Personals.....	435
New Shops.....	435
Supply Trade Notes.....	436
Catalogs.....	438

Ten Dollars for a Good Letter

The apprentice boy, on such roads as have adopted modern apprenticeship methods, is far more fortunate than his brother who received his training under the conditions that obtained more or less generally ten years ago. On the other hand, only a few roads have adequate apprenticeship systems to-day. If we are to encourage the best types of young men to enter the service we must make it as attractive as possible. How about the apprentice boys in your shop? Are they given a fair show? Do they receive systematic and adequate training in their trades? What help or encouragement do you give them? For the best practical statement contained in a letter of not more than 650 words on "How Can I Help the Apprentice Boys?" received before September 1, we will send a check for \$10. Other communications which may be selected for publication will be paid for at our usual rates. Don't delay, but sit down and write a letter this evening.

Safety First in Railway Shops

In order that the best results may be obtained from the safety first propoganda in any railway shop, it is of paramount importance that the employees in that shop become so enthused with the idea that their enthusiasm will be evidenced, not by their words, but by their actions. A sign posted in one shop to the effect, "The greatest safety device known is the careful man," speaks volumes. With the best equipped safety devices known there are still loopholes for accidents, and these can only be prevented by educating the employees to be careful. Another excellent practice, which is followed by one road, is to post on a bulletin board a report of every accident that occurs, stating just what the accident was, the result, the condition of the patient and how the accident might have been averted. This appeals to the men through their desire for news concerning their injured comrades, and the postscript as to how the accidents could have been averted is likely to be remembered. Another good plan is to have the personnel of the local shops safety first committees changed frequently, in order that as many men as possible may become thoroughly familiar with the subject by having it brought constantly to their attention for the definite time they serve on the committee. Much has been done by the railroads in providing safeguards, but there is much more to be done in properly educating the employees.

The July Conventions

During the past month the General Foremen and the Tool Foremen met for their eleventh and seventh annual conventions, respectively. Both conventions were very successful. The General Foremen were favored with two noteworthy committee reports on subjects that were of vital interest to them, namely, Valves and Valve Gearing and Oxy-Acetylene Welding. The former occupied sixty-four pages of the advance papers and covered the field in a very thorough manner. Practically all phases of the subject were covered in a clear and concise manner and proved of such interest that the better part of two days was given to its consideration. Its true value will be more appreciated when the bound volume with the full discussion has been received by all the members of the organization and used by them at their individual shops in an endeavor to improve their shop output. F. A. Byers, chairman of the Committee on Oxy-Acetylene Welding, was exceptionally well fitted for that position, having become a thoroughly familiar with that work as perhaps any other member in the organization. The discussion on this subject took the question and answer form, Mr. Byers acting as the information bureau, and many problems were solved and the possibilities of this method of welding elucidated.

The Tool Foremen, in keeping with their past record, disseminated considerable information regarding the work in which

they are actively engaged. Several interesting special tools and methods for performing various shop jobs were mentioned, while there was also lively discussion on safety first. The association went on record as recommending standard reamers for locomotive frame and rod work, something that has long been sought by both the railroads and the manufacturers. As the matter now stands, with no standards for these long and expensive reamers and with scarcely no two roads ordering the same style of reamers, it has been necessary for the tool manufacturers to charge special reamer prices. By the tool foremen getting together and agreeing to a standard, which, from their deliberations, they believe to be the best all around reamer for frame and rod work, they have accomplished something which, if the standards are adopted by the railroads, will be of benefit to all.

A Car Department Competition

"Car inspectors and car foremen very often have valuable ideas, but they have been made to feel for so long that they are of minor importance in a railway organization, that it is hard to get them to talk about them." So writes one of our correspondents. We don't want them to feel that way and have, therefore, arranged a competition especially for their benefit. There are not many jobs on a railroad that require more intelligent and thoughtful effort than that of the car inspector, and the job carries with it, as well, a considerable amount of responsibility. The interchange rules have gradually grown in number until they are almost hopelessly complicated. In looking over them it would seem almost necessary to have a college graduate to comprehend them. Where do the men come from who inspect the cars to see that these rules are lived up to? How were they developed? What special training did they receive? What qualities must they possess? What opportunities are open to them for advancement? These questions have given car department heads great concern for many years. We will give a prize of \$35 for the best article on "How Should Car Inspectors Be Trained and Developed and What are Their Qualifications?" which is received in our office, Woolworth Building, New York, on or before October 1, 1915. Such other articles as are accepted for publication will be paid for at our usual rates. The judges will base their decision on the practical value of the suggestions which are made.

The Supplyman at Conventions

The railway supplyman, with his exhibit, is a welcome feature at the annual conventions of the mechanical department associations. Sometimes, however, he behaves himself in a most awkward manner. It was suggested by an observer at the opening session of one of the recent conventions that the supplyman might profit greatly if a code of ethics could be developed to guide him in his conduct on such occasions. At the time the remark was made the room was crowded for the invocation and address of welcome. The president had worked hard during the year to make the convention as instructive and effective as possible, and was down on the program to follow the address of welcome with the presidential address. He had spent a great deal of time in studying the progress of the association in order to incorporate some pertinent suggestions for its future welfare. His face was a study when, as he arose to read the address, a large number of supplymen began to slip away into the exhibit rooms. Was it common courtesy? Was the president not the chosen representative of his fellows, and was it fair to him or to them to turn their backs on him in this way? It is well known that he had done much to develop and enforce methods of having the members systematically visit and study all of the exhibits. Had the supplymen forgotten this? Could they not have well afforded to spend 15 or 20 minutes in the meeting room even if they felt that they were not specially

interested in the message which was to be given? Can any railway supplyman afford to ignore the technical proceedings of an association whose guest he really is? We believe—we know—that the exhibits are a most valuable adjunct to the mechanical department conventions, but if those in charge of the exhibits do not understand some of the fundamental principles of common courtesy, will it not do much to hurt the entire supply fraternity?

Consolidation of Mechanical Associations

President Scott, in his opening address before the General Foremen's Association, went on record as favoring some such consolidation plan of the railway mechanical associations as that proposed by F. F. Gaines in his presidential address at the Master Mechanics' Convention, and recommended that the chairman of the executive committee confer with the executive committee chairmen of all other mechanical organizations for the purpose of devising some plan by which such a consolidation can be made. This would seem a most logical plan to follow, and if the idea meets with the approval of the other mechanical organizations considerable headway could be made within the next year toward working the plan to a successful conclusion. It cannot be questioned that a supervisory control of the several railway mechanical associations would be beneficial to the associations themselves and to the railways, for, as Mr. Scott says, "It means that the minor associations will receive more helpful recognition from the larger associations, which will lead to a better understanding and closer co-operation along the lines of economy and the standardization of locomotive parts and appliances."

An excellent example of the beneficial results that would accrue from such a consolidation is shown by the Tool Foremen's Association. At its last convention it recommended standards for frame and rod reamers. The tool foremen realized the need of such a standardization and have worked hard and drawn up recommendations that represent the best average reamers for the work involved. Under the present arrangement the question arises: "What will be the result of these recommended standards?" With a consolidation of the association these recommendations would automatically be presented to the proper body for definite action and the work of the tool foremen would not have been in vain.

There are several other arguments in favor of consolidation or supervisory control: It would eliminate considerable duplication of effort; the subjects for discussion would be more logically chosen; a better attendance would be assured at the conventions, and more definite results would be obtained by the various craftsmen thus convening. There is food for considerable thought in Mr. Gaines' recommendation, and it should receive very careful consideration from all the mechanical associations.

Sufficient and Competent Supervision

"The greatest factor in effecting and maintaining shop efficiency is *competent supervision*," is the opening sentence in George H. Logan's report on "Shop Efficiency," presented to the General Foremen's Association at its recent convention. Mr. Logan hit the nail squarely on the head. Competent supervision is necessary throughout the entire mechanical department, and "competent" means that the supervisors should not only be well qualified for their positions, but that there should be enough of them to thoroughly cover the field. The railway supply concerns have not been slow in developing labor-saving and economical devices for use on locomotives and cars and in the shops, nor have the railways been unduly slow in adopting them; but human intelligence is necessary in their use, and that cannot be manufactured.

With all the improved machinery, tools and locomotive attach-

ments the best results cannot be attained unless the men using these improvements are educated to get the most out of them. This is self-evident, and railways have to a certain extent assigned special men to the definite work of educating employees, with very gratifying results; but this work has not been carried to anywhere near its limit. There is still need for more of these "teachers," who, when logically selected and assigned, will produce results that will pay their salaries many times over. What has been accomplished by supervision and education in the use of fuel has been referred to many times in these columns, and it is claimed by several experts who are actively engaged in this work that much better results can be obtained with a larger force of supervisors. Almost every railway shop has a demonstrator who educates the workmen in the proper method of handling the machine tools. A few roads employ traveling car foremen, whose duties are essentially to educate the car repair men regarding the billing of repairs to foreign equipment and the M. C. B. rules of interchange—a very important matter that every road should carefully supervise. The Safety First committees find that their most important duties are to educate the men to be careful. The tool foremen claim that better supervision in the grinding of tools will materially increase the shop efficiency.

And thus it goes; examples without number could be mentioned where supervision, and enough of it, will be a most profitable investment for any road. The education of employees regarding the correct methods of doing their work is of fundamental importance, and to properly educate them a proper supervisory force is necessary. The cost of this force will, of course, increase the overhead expenses, but if the men are properly chosen the returns in increased efficiency will warrant the expenditure.

Prevention of Engine Failures

"Perfect organization in an enginehouse is the cure for engine failures." In considering this statement, which was made at the convention of the International General Foreman's Association, held in July, in Chicago, let us determine first what may be fairly said to constitute a perfect enginehouse organization. Such an organization would accomplish the coal-ing, watering, fire-cleaning, housing and repairing of locomotives in a minimum time, at a minimum expense with a minimum amount of friction, and the work would all be done in such a manner that no after trouble would arise from it. Even granting the possibility of producing such an organization, it by no means follows that engine failures would be eliminated. The enginehouse can go a long way toward preventing failures, but the other branches of the mechanical department must do their full share if they are to be eliminated or the number greatly reduced.

It might be said that the prevention of engine failures should begin with the locomotive design; proper attention given to the conditions under which the engine is to operate will do much to prevent trouble of this kind. But considering the engines already in service, the place to begin the prevention of engine failures is the general repair shop. Back shop repairs, if carelessly or improperly made, will result in engine failures in spite of efficient enginehouse organization. We frequently hear it said that a certain shop has an output of so many engines per month and as a means of arriving at the *quantity* of work which the shop is doing the monthly output of engines may be satisfactory; but what about the *quality* of the work? How long do the engines stay out after they are repaired? They may stay out of the main repair shop the full twelve months, or whatever the time is between shoppings, but what is it costing the railway company to keep them out of the main shop for that length of time? The repair work has got to be done somewhere if the locomotives are to give reasonably satisfactory service, and if it is not done in the main repair shop it has got to be done in the enginehouse, which is saddled with much of the blame for engine failures

which should be placed at the door of the man in charge of the main repair shop.

The quality of the work done in the main shops in making general repairs to locomotives then has a very considerable bearing on the number of engine failures. And still another feature with which the enginehouse has no connection, and which, nevertheless, adds its quota to the engine failure record, is the method pursued in handling the locomotives on the road. On the kind of man employed as road foreman of engines depends largely the extent to which the failure record will be affected in this way. If he is a man who takes a direct interest in his work and in those under him he will see that enginemen and firemen work in harmony to get the most out of a locomotive with the least trouble, and that his men are so instructed in the carrying out of their work that they will prevent steam failures and failures due to leaky tubes so far as is in their power. There is, of course, a certain percentage of engine failures, such as those due to poor coal or to failures of material, which will probably never be entirely avoided, but by far the greater number of failures are avoidable, and, in fact, many of them should be considered a disgrace.

It seems to be popular in some quarters to place the blame for all engine failures on the enginehouse; in fact we have heard a master mechanic state that he considered enginehouses to blame for at least 99 per cent. of the engine failures on his road. With this statement and with the one quoted above, we cannot agree. The enginehouse can do a great deal to prevent engine failures, but unless the locomotives receive back shop repairs of the proper quality and are given the care and attention which they deserve at the hands of the crews operating them, there is a limit in the prevention of failures beyond which an enginehouse organization cannot go, and beyond which the responsibility for failures should not be placed upon it.

NEW BOOKS

Proceedings of the Master Tinnners', Coppersmiths' & Pipefitters' Association. Compiled and published by W. E. Jones, secretary of the association, Chicago & North Western Railway, Chicago, Ill. 83 pages, 6 in. by 9 in. Bound in paper.

This book is the report of the second annual convention of the American Railroad Master Tinnners', Coppersmiths' & Pipefitters' Association, and contains papers on Oxy-Acetylene Welding, Shop Efficiency, Alloys and Their Uses, Tin Roofing vs. Canvas Roofing and Specialized Training.

Experience in Efficiency. By Benj. A. Franklin. 167 pages, 5 in. by 7½ in. Bound in cloth. Published by the Engineering Magazine Co., 146 Nassau St., New York. Price \$1.00.

A few weeks' study of the tendency of the workmen in a certain factory resulted in a saving of \$30,000 a year. None of this money was spent for new equipment and no changes were made in the organization; there was simply a correction made of the wrong conditions. The author of this book tells of some of these wrong conditions, what they actually were and how he found them. The book shows the shop employer or manager who is in difficulty with the problems of increased cost of production and diminishing returns, how success has been worked out by others under similar conditions. The material in the book is collected from the author's experience and while reduced to its simplest elements still shows the character of the problems attacked and the nature of the solutions found. Four chapters are devoted to methods of increasing both output and the quality of direct production; the fifth chapter extends the same principles to the treatment of clerical or non-productive labor and the sixth enlarges the same idea so as to include the entire force. The seventh chapter leaves the individual and takes up the matter of organization while the eighth attacks the problem of reduction of factory expenses.

COMMUNICATIONS

LAYING OUT THE SOUTHERN VALVE GEAR

LOUISVILLE, KY.

TO THE EDITOR:

The Southern locomotive valve gear has been attracting considerable attention for the past year and I believe that an impression has been created that the principle involved in the motion is of very recent origin. This, however, is far from the truth. As early as 1880 there is record of an outside valve gear for locomotives having an eccentric rod driven by a return crank and constrained at an intermediate point by a radius hanger suspended by a curved guide, the free end of the eccentric rod being operatively connected to a bell-crank sustained by the guide yoke. This was described by Charles Brown on page 271 of the October 1, 1880, issue of *Engineering* (London). A description of a similar gear prepared by the writer was published in the *Railroad Gazette*, issue of May 29, 1903, page

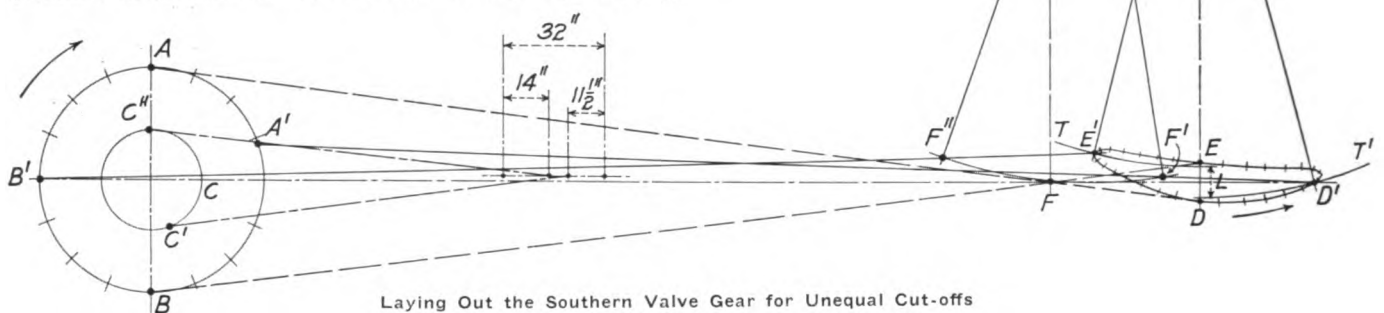

Laying Out the Southern Valve Gear for Unequal Cut-offs

377. Following the gear disclosed by Mr. Brown we have had the Marshall, Bremme, Klug, Wyllie, Strong and finally the Southern gears, all kinematically one and the same.

Referring to the Marshall gear a statement is made in the International Text Book Company's volume on steam engine and boiler design to the effect that no definite rules for its layout can be given. The following direct method of determining the length of the radius hanger and the radius of the curved guide will be of interest.

It is well known that in order to equalize the amount of work done by the two ends of the cylinder, it is necessary to maintain a higher mean effective pressure in the crank end than in the head end, which may be done by providing a later cut-off in the crank end. The diagram shows a method of laying out the Southern valve gear in order to obtain this effect, the diagram being constructed on the assumption of a working cut-off of 11½ in. at the head end and 14 in. at the crank end. Starting with the bell-crank Y, this is shown in the two cut-off positions, the distance L being equal to twice the steam lap on the inside admission valve to which it is directly connected. With S and S' as centers the arcs T and T' are then struck with a radius equal to the length of the transmission yoke. With the crank pin at C', which is its position for a cut-off of 11½ in. in the head end, the eccentric crank will be at A'. The eccentric rod is then laid in position A' F' D', the latter point being the intersection of the loci of the free ends of the eccentric rod and the transmission yoke. With the crank pin at C'', which is its position for a cut-off of 14 in. in the back end of the cylinder, the eccentric crank is at B' and the eccentric rod has position B' F'' E'.

Points D and E on the ellipse are fixed by the lap and lead of the valve, the distance between them being equal to twice the lap plus twice the lead. With the crank pin then placed successively on the two dead centers, the eccentric crank will be located at A and B respectively, the eccentric rod occupying the position AFD and BFE respectively, intersecting at point F, which determine the location of the radius hanger connection. With the distance of this point from the end of the rod de-

termined, the points F' and F'' showing the location of the radius hanger connection for the two cut-off positions may be located.

Determining the length of the radius hanger and the radius of the reverse link is now in order. The length of the radius hanger is determined by locating a point, W, which is equidistant from points F', F and F'', the distance WF being the required length of the hanger, and the arc OW, struck from the point F as a center, becomes the center line of the reverse link. Point

W' is the position of the link block center in the working cut-off under the conditions assumed.

In order to avoid the erasure of trial arcs in determining the point W a piece of transparent paper or tracing cloth may be placed over the drawing to good advantage while doing this work.

HARRY CORNELL.

WATER IN COAL MINES.—For every ton of coal raised from one of the anthracite mines, the operators of that field are obliged to pump to the surface about eleven tons of water. It is estimated that in the anthracite mines there are 900 pumps in use at the present time. The capacity of these pumps is approximately 1,000,000 gal. a minute.—*American Machinist*.

EFFECT OF SPEED ON GRINDING WHEEL WEAR.—Grinding wheels appear softer at slow speed because the metal being ground tears the grinding particles away from the bond which holds them together. Don't condemn a wheel as being too soft until you are sure that its cutting speed is correct.—*Iron Trade Review*.

STEAM VELOCITY IN PIPES.—The velocity of steam in pipes commonly allowed for medium and high pressure is 6,000 to 8,000 ft. per min., but the tendency of the present is toward much higher velocities (even to double the figures given), especially where considerable initial superheat is given the steam.—*Power*.

SMOKE CRUSADE ABANDONED IN BALTIMORE.—That the smoke crusade in Baltimore has been a failure and that the smoke abatement commission has done little or nothing, is the statement made by Mayor James H. Preston of that city. Several months ago the smoke inspector, dissatisfied with the progress of the commission, tendered his resignation, but it was not accepted. It is believed now that it will be accepted and that further efforts on the part of the city to abate the nuisance will be abandoned.—*Iron Age*.

HOW DO YOU SELECT YOUR MEN?*

Simple and Practical Suggestions Looking Toward the Solution of a Most Difficult Problem

BY ROY V. WRIGHT

Possibly no one problem is of greater importance to the railway executive or industrial manager than that of knowing how best to select men either to enter the organization at the bottom or for promotion to more important positions. We can analyze the properties of materials and predict their performance under given conditions with more or less accuracy. The human element, however, which controls the use of these materials and is by far the most important factor in determining the efficiency of operation of a manufacturing plant or a railway property is far more difficult to analyze and direct with a view to securing maximum efficiency. The necessity of giving greater attention to this element has become more and more evident in the intensive development toward greater efficiency which has been so marked during recent years. The selection of men is such a complicated problem, however, that many executives have gone on as best they could feeling that science could contribute little toward its practical solution.

Vital as is this problem to a manufacturer or industrial plant, it is far more important to the railway with its forces scattered widely and with the higher executive officers, and many even of the minor ones, unable to keep in close or intimate touch with their subordinates.

In attempting to solve the problem of the selection of men some have looked to experimental psychology, such as is exemplified in Professor Hugo Munsterberg's work and particularly as outlined in his book on "Psychology and Industrial Efficiency." Others have looked into the theory of phrenology, feeling that possibly it might be used to determine the characteristics of different individuals with a view to seeing whether they were fit for promotion or whether by this means men could be selected with any degree of success for performing certain specific classes of work. Then we have had the theories of Dr. Katherine M. H. Blackford, which take into consideration certain physical characteristics, including color (blond or brunette), shape and profile of head, size, structure, texture (fineness or coarseness of fibre or grain as seen in the hair, skin, nails, features, hands, feet and general body build); consistency (hardness, softness or elasticity of bodily tissues), proportion, expression and condition of body, clothing, etc. Dr. Blackford it was who placed special emphasis on keeping three things in mind in selecting a man for a job: First, the type of job; second, the characteristics of the man himself, and third, and possibly equally important, the characteristics of his boss. Some of the claims which are made for this science of character analysis are defined in an advertisement in one of the recent numbers of a popular magazine in the following words:

In this course you learn to judge others quickly and accurately. You learn to know what a man's appearance means—his face, his head, his hands, his eyes, his expression, his walk, his handwriting—everything about him. You do not measure his head or ask him questions or let him know in any way what you are doing. There are no repetitions, no theories, but a clean-cut presentation of the principles underlying human character—with so many photographs, diagrams and charts that you can learn and apply the principles rapidly and easily, etc., etc.

Of how much value are all of these things? How much reliance may be placed upon them? If they are not satisfactory or reliable, is there any practical way of selecting a man for a job or for promotion with a fair degree of certainty as to his fitness for the position? The remainder of this brief talk will be devoted to answering these questions.

Most of you have undoubtedly heard of Dean Hermann Schneider of the University of Cincinnati, and possibly some of you are fortunate enough to have had the pleasure of meeting and becoming acquainted with him. He it was who first put into effect in a big way the idea of having practical and theoretical training go hand in hand in engineering education, by securing the co-operation of the machine tool builders and manufacturers of Cincinnati with the university, and in establishing the co-operative engineering courses. The wonderful results which followed this experiment make a long story and doubtless are familiar to many of you. Suffice to say here that the results were so eminently practical and so striking that in one form or another the methods are rapidly being extended far and wide, both in connection with engineering courses, in colleges and universities which are so located as to be able to secure the co-operation of industries, and also in many lines of industrial and vocational training throughout the country.

As a concrete example, let us consider what happened in one large department store. Those in charge felt that the sales force was not doing its best work because the employees were not properly trained, either in general education or as to their knowledge of the merits of the products which they sold, to deal to the best advantage with the leading people of the city who did their shopping in the store. Manifestly there are certain times during the day when it is not necessary to have all of the sales force on duty. Arrangements were made with the city school system to provide instruction during these periods, to those who could be spared, in English, civics and other studies which would develop the employees into bigger and broader men and women and make better citizens of them. Then, too, the employer, who provided and fitted up the school-room, saw to it that expert instruction was given in the methods of manufacture and as to the merits of the different products which were sold.

The latest development along this line is the general vocational training movement which is spreading throughout the country. New York City, for instance, has gone into the matter on a large scale and has retained Dean Schneider as one of its chief advisers. In the Woolworth Building, where our offices are located, the representatives of the city school system have made a canvass to find whether a sufficient number of employees can be spared at different times during the day to warrant the fitting up of a school-room and the providing of instruction in the building. At the shops of the Baltimore & Ohio on Staten Island the city is co-operating by providing instruction to the apprentices, the railroad furnishing the school-room—an old passenger car—and the Board of Education of the City of New York paying the salary of the teachers, who in this particular case are employees of the railroad, and also for the material used.

I have outlined this development thus fully, not because it has any special bearing on the subject under discussion, but because I want you to have some idea of what Dean Schneider has done and of that for which he stands. He is a man with a hobby, but he is big enough to see over and around it. He has a keen and analytic mind and is capable of sizing a problem up from a broad and liberal viewpoint. He has a splendid supply of patience and is absolutely unselfish in his efforts to help others.

In connection with the work of the co-operative engineering courses at Cincinnati, which have been carried on for a num-

* An address given at a luncheon of railway officers at the Auditorium Hotel, Chicago, Tuesday, June 29, under the direction of the General Railroad Committee of the Chicago Y. M. C. A.

ber of years, Dean Schneider and his associates have come in contact with hundreds of young men whom they have had an opportunity of studying critically and whose progress along both practical and theoretical lines they have been able to observe and follow closely. Because of the nature of the work, the students spending alternate weeks in the manufacturing shop and in the class-rooms at the university, the instructors and shop co-ordinators can get closer to the students and know them more intimately than under the usual conditions. Moreover, they have been able to follow many of these men after they left the institution and to observe their progress.

As stated by Dean Schneider in a paper entitled "The Problem of Selecting the Right Job," which was recently presented before the third annual convention of the National Association of Corporation Schools, "one leg of the tripod upon which the co-operative system of education rests is the selection of men for the work for which they are to be trained." The university authorities, on the basis of their study and observation of the individual students, now guarantee to Cincinnati manufacturers for certain jobs men who have finished three years in the co-operative course.

In the effort to determine whether phrenology, physical characteristics or applied experimental psychology had any merit in such selection, a great number of experiments were made on mature students whose characteristics and qualities were well known, but not by those actually conducting the tests. The tests demonstrated conclusively that these systems were not at all reliable and that the only practical and successful way of selecting men is by testing them out on the actual job.

Concerning the tests as to physical characteristics Dean Schneider stated: "This seems to be a development of the old idea of phrenology. It is claimed in this system that physical characteristics indicate certain abilities. For example, a directive money-making executive will have a certain shaped head and hand. A number of money-making executives were picked at random and their physical characteristics charted. We do not find that they conform at all to any law. Also we found men who had the physical characteristics that ought to make them executives, but they were anything but executives. A number of tests of this kind gave negative results. We were forced to the conclusion that this system was not reliable."

As to applied experimental psychology the Dean had this to say: "The science of applied psychology seems to be at the point where chemistry was when it was alchemy; we may hope, however, that Illusion is the First Appearance of Truth."

It is not my intention, and I very much doubt if it was Dean Schneider's intention to unqualifiedly and wholly condemn these things. It is quite possible that they may contain certain elements of truth. The trouble is that they are being carried to a ridiculous extreme. If on the other hand they are instrumental to some degree in awakening executives to the importance of the problem, they will have served a useful purpose.

Dean Schneider finally concludes, on the basis of the study and testing of about 1,000 mature students, both in theoretical and practical work, that: (1) A worker's failure is as significant as his success and should be analyzed to indicate a new and fitting job; (2) the characteristics developed by analysis of many successes and failures furnish a basis for placement which works better than any plan we know; (3) the method is crude and unscientific; it requires a period of time much greater than other methods proposed, but it insures a reliable verdict.

Knowing of the man and his work as we do, we are pretty safe in accepting his conclusions. Doubtless they agree fairly closely with those of many in the audience who, however, have not been in a position to prove their correctness, not having had the exceptional opportunities for observation possessed by Dean Schneider.

On these conclusions as a basis, how can we go ahead logically to induce the supervising officers to study more critically

the characteristics and work of the men who enter the service, with a view to determining whether they are properly fitted for the tasks to which they are assigned? It would seem that in hiring men the initial selection should be made by members of the organization who have some special ability in sizing men up; then if they are closely watched and given a thorough trial on actual work, it should be possible to determine within a reasonable time whether they are the sort of men that will prove satisfactory and along just what lines it will be best to develop and train them.

The trouble under present methods is that a new man taken into the organization is in most cases not given any systematic attention. If he is very bad he is fired. If he is passably good he is allowed to remain; but no one knows with any degree of certainty whether he is the best man for the job, or whether he is capable of doing better work or not.

A simple method of checking the personality and performance of these new recruits will be described. It was not developed and used especially for that purpose, but is admirably adapted to it, as well as for checking men already in the service with a view to determining whether they are properly placed, along what lines they can best be developed and just which ones are best suited for promotion to more important positions. It has been tried out on a large scale with splendid results and is inexpensive to install and maintain. It cannot be successfully inaugurated or followed up, however, unless it has the enthusiastic backing and support of the higher executive officers.

Briefly, the scheme is as follows: Each foreman or supervising officer is provided with a sufficient number of special report cards to cover each one of his immediate subordinates, which he is required to fill in and return to his superior officer. He is not expected to keep any copy of these reports and is called upon at periods, of say six months, to make similar reports on each man. The comparison of the reports for any individual will show whether he has made progress in improving his weak points. If he has not, or has apparently fallen behind, his superior is asked for an explanation and is held responsible either for failure to properly train and develop the man or for lack of accuracy in sizing him up. In this way the foreman is automatically compelled to study his men more closely, and the effect in improving and developing the executive ability of such officers is a most noteworthy feature.

The characteristics upon which a report is made are such as to indicate a man's fitness for holding a position in the organization and as to whether he is worthy of promotion. The items on a report card,* which was used by LeGrand Parish, with standard and concise definitions, are as follows:

- EDUCATION: Mental and moral training.
- SPECIAL KNOWLEDGE:
- EXPERIENCE: Knowledge acquired by actual trial and observation.
- HONESTY: Upright disposition or conduct.
- MORALITY: Accord with the rules of right conduct.
- TEMPERANCE: Moderation.
- TACT: Ability to do or say what is best for the intended effect.
- RESOURCE: Good at devising expedients.
- RELIANCE: Sure dependence.
- FORESIGHT: The act or power of foreseeing.
- APPEARANCE: Outward look or aspect.
- MEMORY: Mental hold on the past.
- ENERGY: Active, effective.
- INITIATIVE: The ability or disposition to take the lead.
- PERSISTENCE: Steady or firm adherence to, or continuance in a state, course of action, or pursuit that has been entered upon.
- ASSERTIVENESS: Affirming confidently, positive.
- DISCIPLINE: To teach rules and practice and accustom to order and subordination.
- PROMPTNESS: Quickness of decision or action.
- ACCURACY: Correctness.
- SYSTEM: Regular method or order.
- ORGANIZATION: A systematic and regulated whole.
- EXECUTIVE ABILITY: Ability to carry into effect in a practical manner.

* For more complete description of this card see *American Engineer and Railroad Journal*, December, 1908, and *Railway Age Gazette*, July 23, 1915, page 151.

A man is graded, as very good, good, medium or poor in each of these characteristics.

This scheme eliminates the "hit and miss" method of selecting men for promotion and was instrumental in locating suitable men with considerable accuracy. Too often when it comes to promoting men a decision is based on the man's recent performance, when he may have done some spectacular piece of work which placed him in the limelight but which may not give any indication of his fitness for holding an executive position. The men throughout the organization, understanding that these records were being kept, were encouraged to improve and better themselves. Men who were unsuited for the work to which they were assigned were discovered and transferred to tasks for which they were better fitted, or if they were found hopeless, were eliminated from the organization.

These report cards were developed ten years or more ago and remained in use several years until Mr. Parish left railway service—long enough to demonstrate their value beyond question. In the light of experience it was Mr. Parish's idea to revise the characteristics, including some which are not shown in the list quoted and eliminating or changing others.

It so happens that Dean Schneider, in making his observations, employed record cards of a somewhat similar nature, but possibly of a broader scope and more closely approximating the ideal toward which Mr. Parish was working. The characteristics noted on Dean Schneider's records were as follows:

Physical strength, or physical weakness. In some occupations physical strength is essential; in others it is not.

Mental, or manual. This may be stated in another way and in rough terms as "head efficiency" as compared with "hand efficiency."

Settled, or roving. Some men work best under a steady routine; others like to move about and see or do new things.

Indoor, or outdoor. Some men thrive best under outdoor work; others prefer indoor work.

Directive, or dependent. Some men assume responsibilities; others evade them.

Original (creative), or imitative. Some men are fertile in making suggestions; others do not possess this quality but are good at putting them into effect.

Small scope, or large scope. Some men like to fuss with intricate bits of mechanism; others want tasks of big dimensions.

Adaptable, or self-centered. The first might make a good salesman; the second a statistician.

Deliberate, or impulsive.

Manual accuracy, or manual inaccuracy.

Mental accuracy (logic), or mental inaccuracy.

Concentration (mental focus), or diffusion.

Rapid mental co-ordination, or slow mental co-ordination. Some men go to pieces in an emergency, whereas if they were given time to consider the situation they hold together and act wisely.

Dynamic, or static. One man may lack push or determination; others having the dynamic quality possess these characteristics.

Little has thus far been said as to the necessity for providing some adequate means of training the men in all of the departments. Its importance immediately becomes apparent in developing a system such as that outlined above. That it pays generous dividends is indicated on such roads as have installed modern apprenticeship systems for mechanical department employees, or have developed educational campaigns for improving conditions and securing greater efficiency or economy in other departments. It is unfortunate that more attention is not being given to this subject by railroads generally.

In this connection allow me to quote a few paragraphs from an address on "Training of Young Men with Special Reference to the Question of Promotion,"* which was given by George M. Basford before a recent meeting of the Burlington Association of Operating Officers.

"To-day we are looking for the genius and are overlooking the production of good workmen. We are depending upon officers. We need to depend upon men. Trained, properly educated and encouraged workmen will provide good officers later.

"Systematic methods of selecting human material for the organization are imperative. The boys in offices, in shops, and all along the road should be most carefully and intelligently selected. Someone well qualified must be given this responsibility. Then these recruits must be tried out, and those 'making good' must be trained. This word 'trained' represents a new meaning as applied in this connection. It means thorough education of hand and brain and conscience.

"Because of the size of a railroad organization it is necessary to provide easy and automatic methods of discovering ability. It is desirable that promotion should be proposed by co-operative action by subordinate officials and controlled by a very high official whose authority is complete in this case. Suppose the president of a railroad could find a man qualified for the duty of directing the training and promotion of men. The difficulty in finding such a man emphasizes the importance of the duty. This man should be given a dignified, powerful position, with such a title as Assistant to the President. He should be responsible for methods of recruiting, methods and means of training men, and for a scheme whereby he will personally know that every promotion is based upon merit, with favoritism and politics banned. He should be responsible for and personally approve every promotion in the entire organization."

Mr. Basford then describes the report cards which were used by Mr. Parish, and among other things concludes: "Our Assistant to the President need not personally watch all these cards. He should, however, by frequent checks know positively that every department head is watching them, and he should personally keep the records of all important officials. He should also require record cards for a long period to accompany a recommendation for promotion. For example, a vacancy as assistant superintendent is to be filled. The Assistant to the President would call on all interested departments for recommendations and the office would be filled after an intelligent and complete investigation of all eligible men, including the mechanical and track as well as the operating department. The plan should cover every department."

The scheme suggested by Mr. Basford, if put into effect, would do much to make positions on the railroad more attractive to ambitious young men and would undoubtedly develop means for locating such men in the territory served by the road and of getting them to enter its service.

In conclusion the point which I especially wish to make is that it is imperative from the standpoint of future efficiency and economy that each organization should formulate and adopt a policy, which will have the hearty support and backing of the executive officers, as to the selection of men for the different jobs; the proper training of these men in order to make their efforts as effective as possible, and a comprehensive method of selecting men for promotion. If this is done—and it is not a matter which can be accomplished in a week, a month or a year—it will not only increase the efficiency of each individual in the organization to a maximum, but it will encourage loyalty on the part of all of the employees and develop an *esprit de corps* which will do much to eliminate friction and labor difficulties and will place any organization which possesses it in an enviable position as to efficiency and effectiveness.

*For full text of address see *Railway Age Gazette*, July 23, 1915, page 15.

RECIPROCATING AND REVOLVING PARTS

BY H. A. F. CAMPBELL*
III.—BRITISH DESIGN

Through the courtesy of the mechanical department officers, the writer has received drawings showing the details of the

V for American locomotives. It will at once be seen that the weights per unit of load are far in advance of our regular practice and indeed are right up to the figures obtained on those American engines where special care was used to reduce the weight and already shown in Part I.

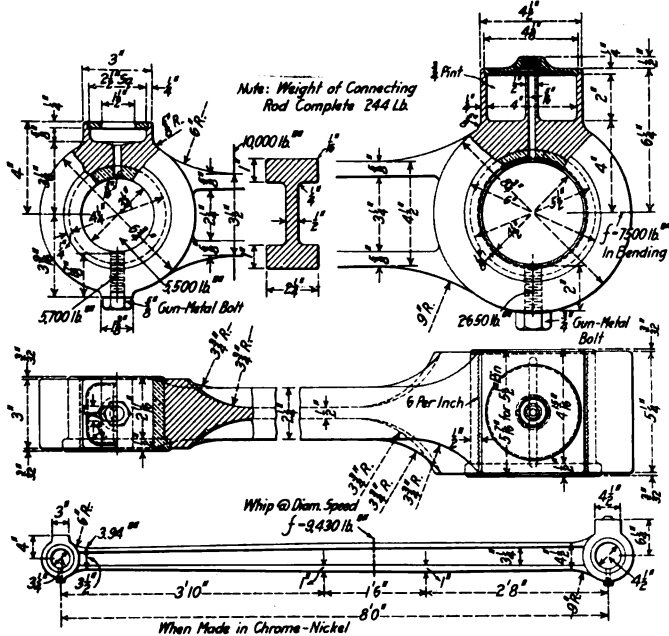

Fig. 31—Outside Main Rod of the Great Western Locomotive

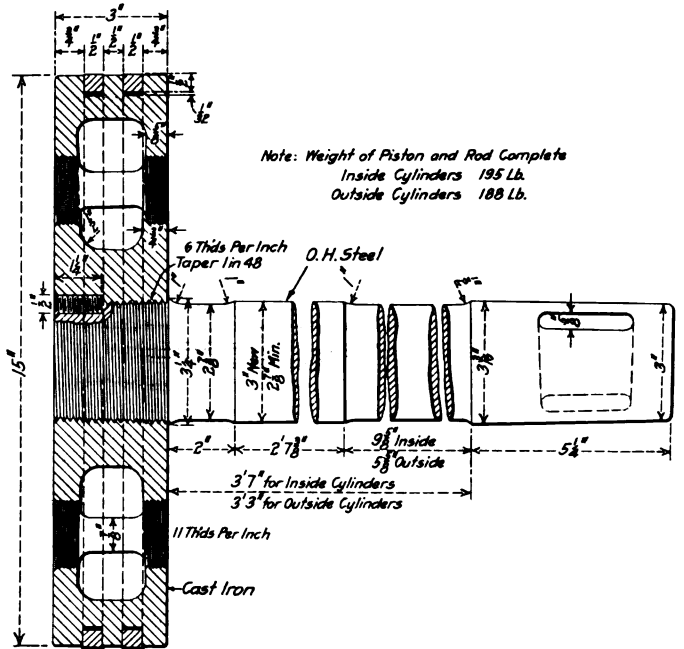

Fig. 33—Piston and Rod of the Great Western Engine

reciprocating parts used on some of their latest locomotives. Lack of space will prevent showing all the designs; this is to be regretted because each is worthy of careful study. Table XII, however, gives the detail weights of the reciprocating parts

Considered as a general average, these stresses are very little, if any, higher than the stresses in regular use in America. With one exception the steel is the regular open-hearth carbon of 80,000 lb. per sq. in. ultimate strength, although it is the

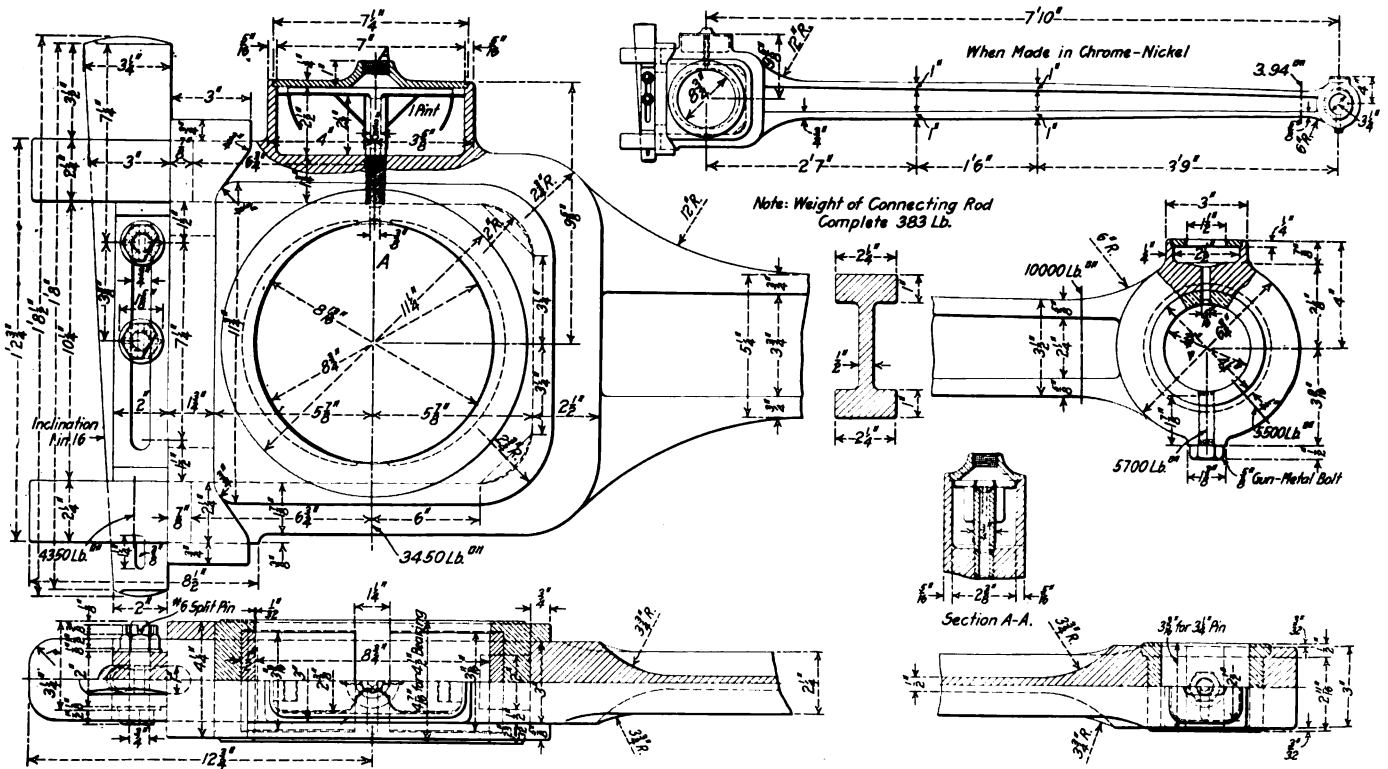

Fig. 32—Inside Main Rod of the Great Western Locomotive

of six English engines. The weight of each part per unit of load carried has been worked out as was done in tables I to

Siemens-Martin acid steel and not basic steel. The reduction in weights, then, cannot be said to be due to the use of special steel, nor to the use of higher stresses. The saving in weight

*Baldwin Locomotive Works, Philadelphia.

has been made by the choice of the type of part used. Light types of pistons, crossheads and stubs have been chosen.

These examples of English design illustrate the point already made, that considerable reduction in weight can be made by simply choosing a light type of part. If, then, special alloy

only 244 lb. and carries 160 lb. of piston load per lb. weight of rod. For the length nearly 100 in. center to center, this is the lightest main rod that has come to the writer's attention.

For a detailed description of the reciprocating parts, the

TABLE XII—DATA FOR RECIPROCATING PARTS OF BRITISH LOCOMOTIVES

Road and type	Cylinders and driving wheels	Boiler pressure, lb.	Piston load, lb. (area piston x full b. press.)	Weight, lb.			Total wt. of reciprocating parts, lb.	Piston load, lb. per lb. wt.			
				Cross-head	Piston rod	Main rod		per lb. rec. parts	per lb. wt. crosshead	per lb. wt. piston	per lb. wt. main rod
Great Western, 2-cyl., 4-6-0...18½ in. x 30 in.; 80 in.....		220	59,100	258	330	473	824	71	230	180	125
Great Western, 4-cyl., 4-6-2...15 in. x 26 in.; 80 in.....		220	39,000 inside	193	195	383	541	74	202	200	102
Great Central, 2 cyl., 4-6-0...21½ in. x 26 in.; 81 in.....		180	65,300	231	375	592	783	83	283	174	110
L. B. & S. C., 2-cyl., 4-6-4...22 in. x 28 in.; 81 in.....		170	65,000	208	425	575	920	70	310	152	112
L. B. & S. C., 2-cyl., 4-4-2...21 in. x 26 in.; 79½ in.....		160	55,000	191	347	476	776	71	288	158	115
Midland, 2-cyl., 2-8-0.....21 in. x 28 in.; 55½ in.....		190	65,800	137½	343	500	713	90	480	192	131
Average.....		78½	301	180	122

steel should be used and the designer has full confidence in the material, and works it up to its full capacity as regards strength, a still further saving is made in weight. This combination of choice of types and the use of alloy steel is clearly

following locomotives have been chosen: Great Western, 4-6-2 type, four-cylinder, simple; London, Brighton & South Coast, 4-6-4 type, two-cylinder, simple; Midland, 2-8-0 type, two-cylinder, simple.

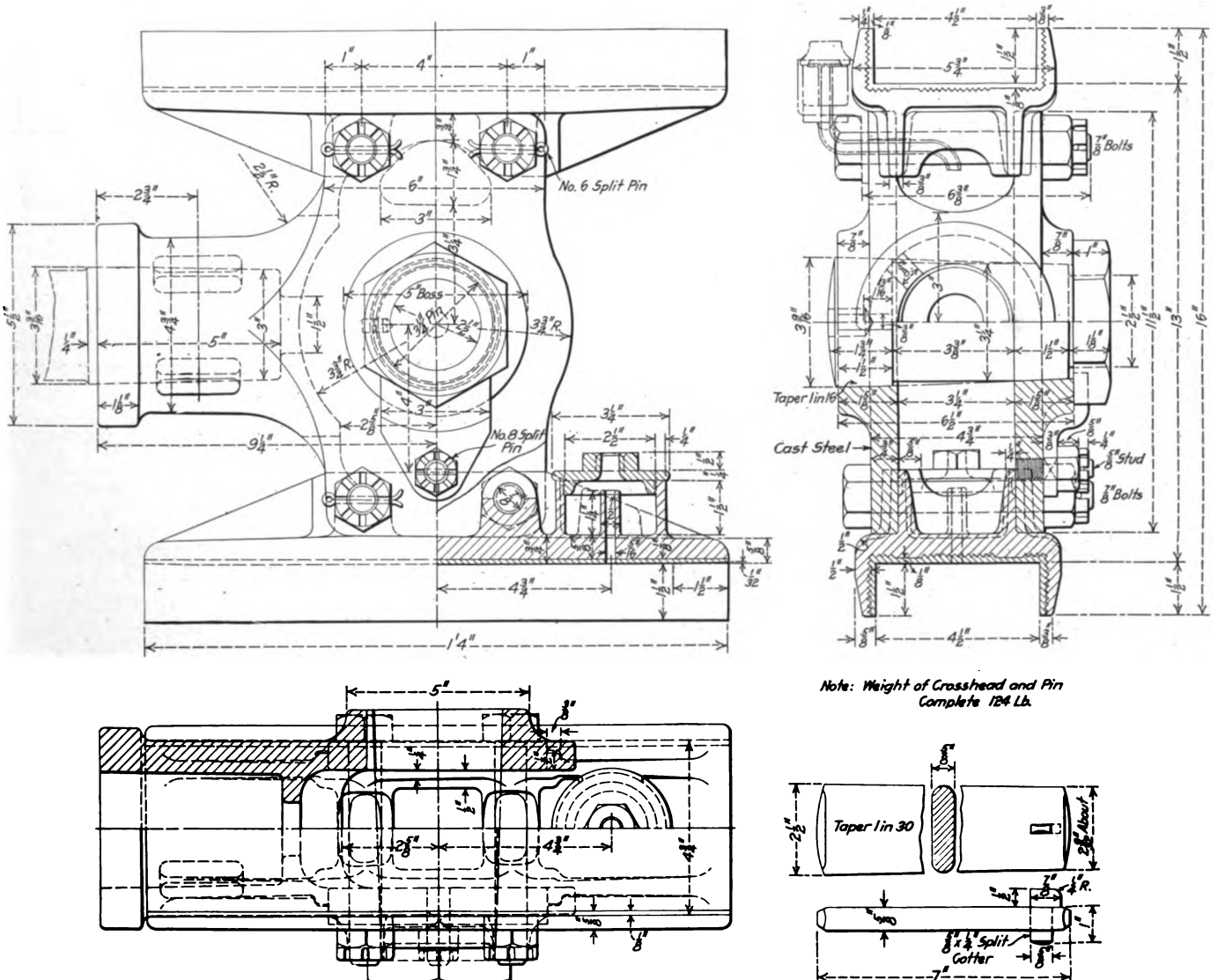

Fig. 34—Outside Crosshead of the Great Western Engine

illustrated in the outside main rod of the Great Western's Pacific type locomotive, Fig. 31. This rod complete weighs

The Great Western Pacific type is a four-cylinder balanced simple locomotive; the cylinders are 15 in. by 26 in., the

boiler pressure is 220 lb. per sq. in. (superheated steam), and the diameter of the drivers is 80 in. This locomotive is shown in the photograph. The outside and inside main rods are shown in Figs. 31 and 32. Both rods are nearly of the same length. The stresses are noted at the different sections for the outside rod. This rod is made of nickel-chrome steel, and as already stated, weighs only 244 lbs., but while the stresses are not low, it will be seen that they are well within the capacity of material of this character.

CHARACTERISTICS OF PLATE SPRINGS*

BY GEORGE S. CHILES

PART II—(Concluded)—DESIGN

The action of a plate spring is similar to that of a simple beam supported at the ends and carrying a concentrated load at the center. The effect of a load upon such a beam is to cause it to bend; the tendency being to place the fibers at the upper surface in compression and those of the lower surface in tension. The

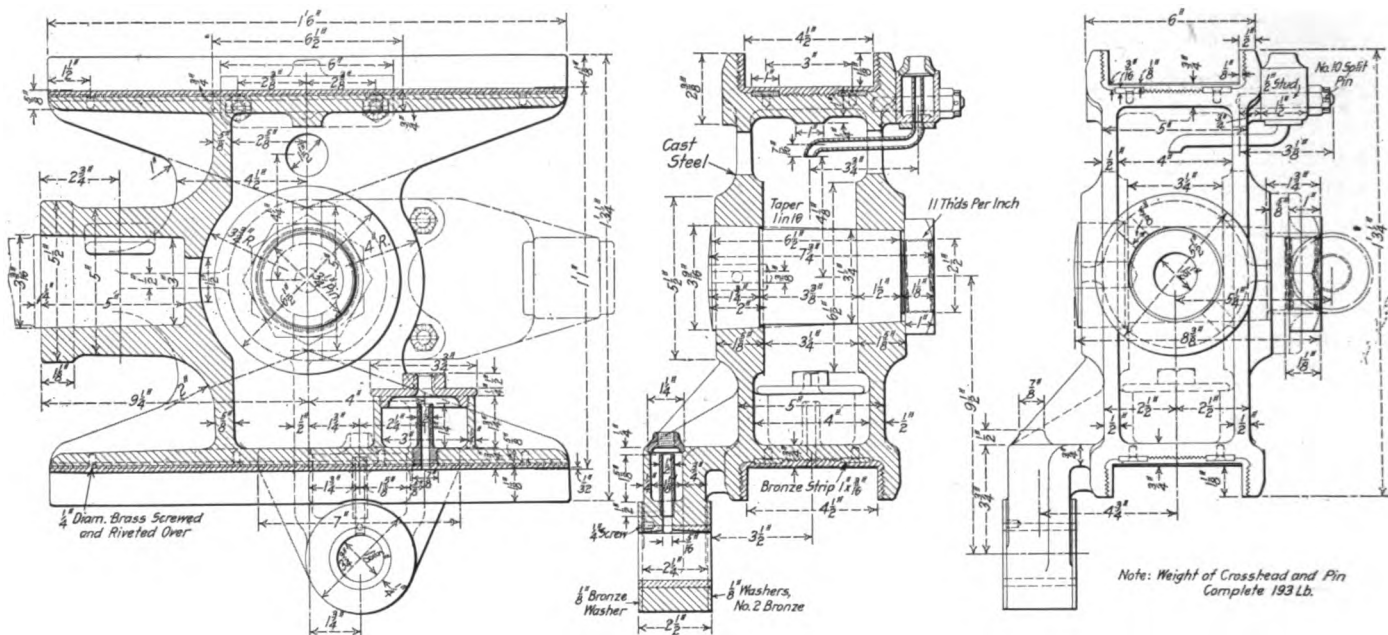
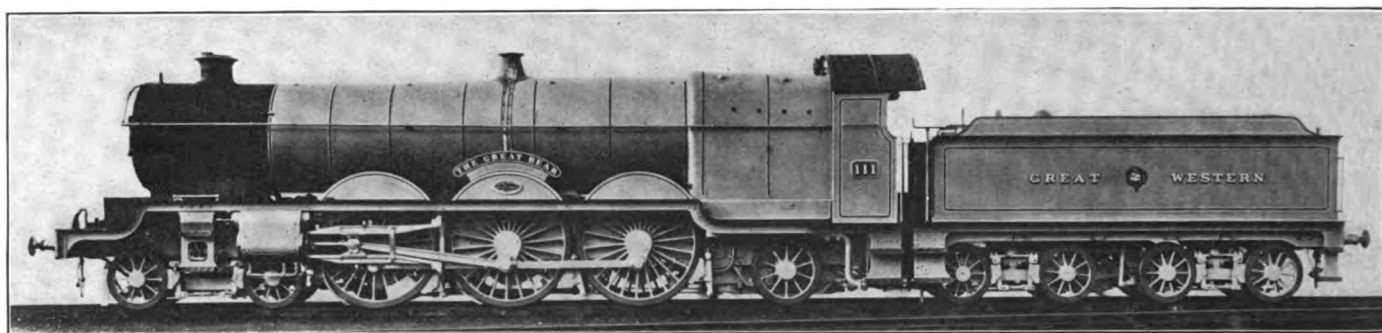

Fig. 35—Inside Crosshead of the Great Western Engine

Fig. 33 shows the piston. This is of the usual box type and is made of cast iron. Figs. 34 and 35 show the crossheads for both the outside and the inside cylinders of the Great Western

intensity of the stresses increases directly as their distance from the neutral axis, the minimum stress being at the outer fibers; this is shown at the right in Fig. 20.



Four-Cylinder Simple Pacific Type Locomotive; Great Western of England

engine. The stresses at the different sections in these crossheads are shown in table XIII.

TABLE XIII—STRESSES IN PISTON ROD AND CROSSHEAD OF GREAT WESTERN PACIFIC TYPE LOCOMOTIVE

Section, and kind of stress	Amount of stress, lb. per sq. in.
Shear on key.....	13,850
Tension in rod through keyway.....	8,000
Tension in neck of crosshead through keyway.....	4,200
Crushing of key on the rod.....	21,000
Crushing of key on the crosshead.....	37,000
Bearing pressure, pin on crosshead.....	3,680
Compression in main shank of rod.....	6,090

In addition to the bending stresses which act normal to a section, the beam is subjected to shearing stresses. At any section of the beam, the shear is equal to the sum of the vertical components of the external forces or loads on one side of that section. It is quite generally assumed that the shearing stresses are uniformly distributed over the cross section of the beam; in reality, the unit shearing stress at the neutral axis of a rectangular section is 50 per cent. greater than the mean value and is zero at the upper and lower edges.

Considering the case of a simple beam loaded at the center and

*The first instalment of Part II. appeared on page 340 of the July, 1915, issue.

supported at the ends, uniform strength for simple bending may be secured by varying the breadth B in proportion to its distance from the end support; in other words, by making the

the spring to withstand the shearing stresses, the other that one surface of the outline of a spring should conform to a straight line and the other to a parabola. This is not borne out by

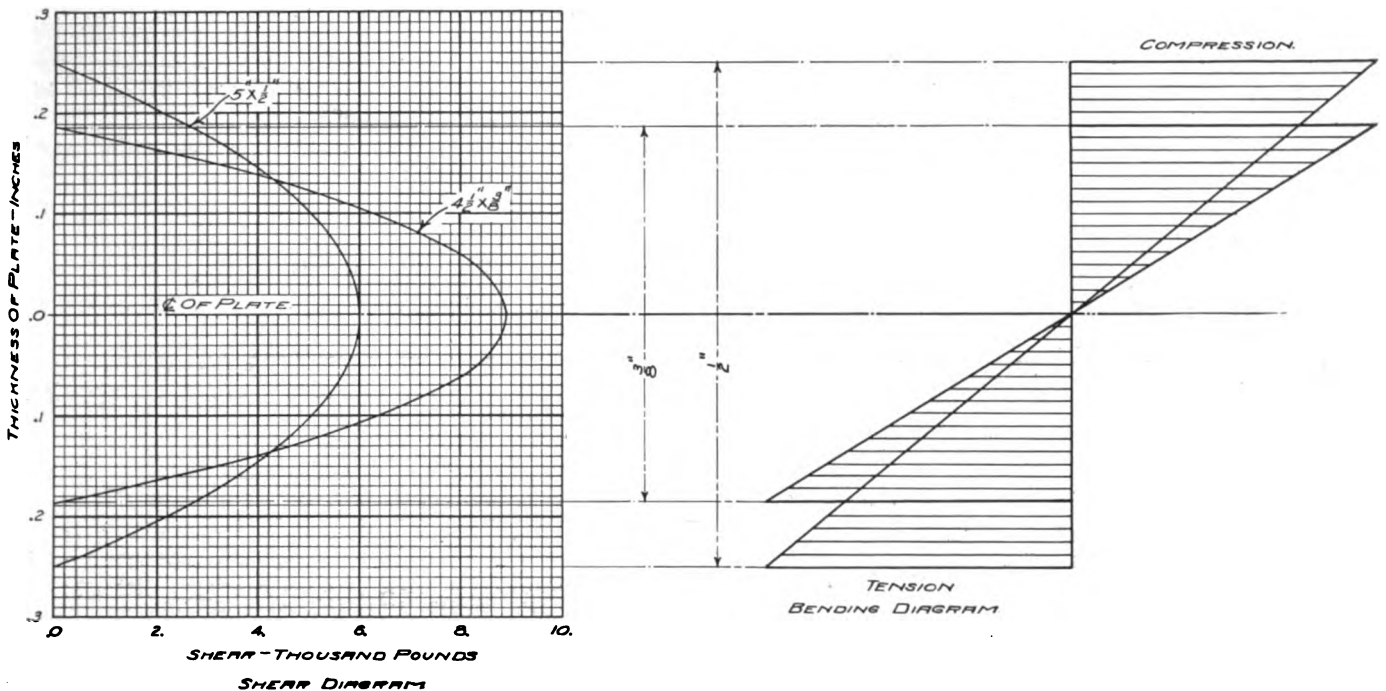

Fig. 20

beam of constant depth and diamond shaped in plan, as in Fig. 21.

Now, instead of using the diamond-shaped plate, if we cut equal widths of spring steel similar in shape and number to the strips 1, 2, 3, etc., at the top of the figure, and arrange them as in the two lower diagrams, we have a simple form of plate spring. It would be necessary in such a case to extend the main plate and it is the common practice in this country to roll the majority of the plates as is illustrated at the bottom of the figure, rather than taper them as shown in the diagram. Either method may serve the purpose if properly performed. Where the practice of tapering the plates is followed, the ends of the plates are usually tapered back so far that the end of one plate extends beyond the base of the taper of the next longer plate. In some instances where the plates are not-rolled the corners are clipped off.

A discussion of the stress distribution in plate springs and how trimming the plates alters this distribution will be found in a paper entitled "The Determination of the Stresses in Springs and Other Bodies by Optical and Electrical Methods," read before Section G of the British Association at Dundee, September 11, 1912, by E. G. Croker, M.A., D.Sc., Professor of Mechanical Engineering in the City and Guilds of London Technical College, Finsbury, and published in *Engineering* (London), September 20, 1912. For the purposes of this article, it is sufficient to state that it is questionable as to whether any advantages are derived from the practice of tapering the ends of the various plates where the spring consists of a large number of plates.

Neglecting the effect of the friction between the plates, the strength and deflection of a spring as shown in the lower half of Fig. 21 would be similar to the diamond-shaped beam of thickness H , and considering the bending stresses only, the outer fibers are all stressed to the same degree. As a general rule, however, a plate spring only approximates a beam of uniform strength in that from a quarter to a fifth of the total number of plates extend the full length and in such cases are not rolled, with the possible exception of the last one. Two reasons are quite often advanced for thus deviating from a beam of uniform strength, one being to provide sufficient material at the ends of

the built-up beam of uniform strength shown in Fig. 21.

As an example of the stresses due to the shearing action let us consider two springs, one with the plates five inches by one-

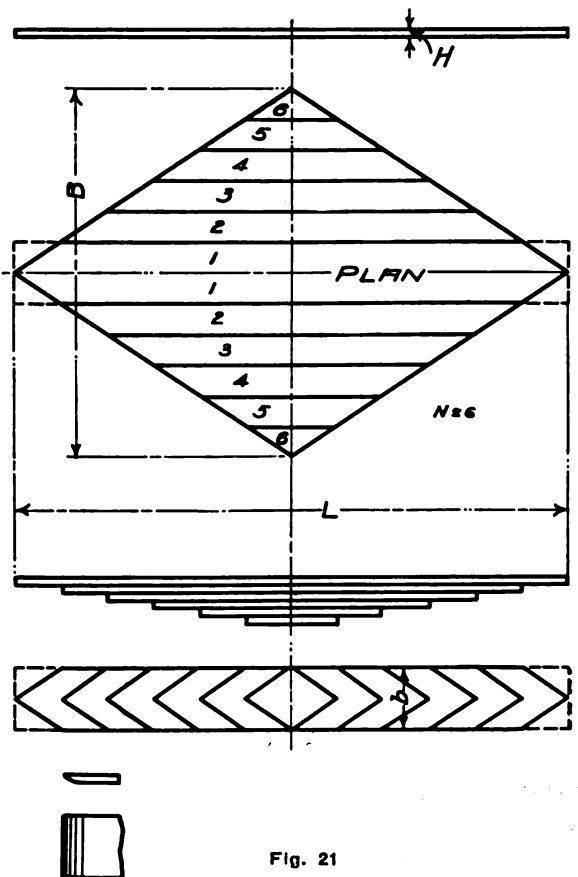

Fig. 21

half inch and the other four and one-half inches by three-eighths inch which are designed for a static load of 20,000 lb.

each, and assume that in each case the total shear is to act upon one plate only. Now, since for rectangular cross-sections, the shearing stresses vary as the ordinates of a parabola whose middle ordinate is equal to one and one-half times the total shear divided

by the area, or $\frac{2a}{3s}$, the values for the maximum vertical shear are

6,000 lb. and 8,900 lb. respectively. We know that, if at any point in a strained body there is a shearing stress in one plane, there must of necessity be a shearing stress of equal intensity in another plane which is at right angles to it, each plane being perpendicular to the direction of the stresses in the other plane. The shear diagram in Fig. 20 indicates the location and extent of the vertical and horizontal shear at any section of the plates of either spring referred to. These purely shearing stresses are equivalent to resultant normal stresses at an angle of 45 deg. to

per sq. in., or an increase over the tensile stress of 1.2 per cent. This increase is so small as to indicate that the shearing stress in any ordinary plate spring is not of sufficient importance to warrant the use of additional full length plates. Practically, however, the spring should contain more full length plates than are theoretically required, inasmuch as the breaking of a full length plate near the end would cause the adjoining plates to be subjected to a greater stress than would the failure of a plate near the center of the spring.

The section modulus at the center of a plate spring may be calculated by the formula :

$$SM = \frac{nbh}{6}$$

where n = number of plates of full section;
 b = width of plate in inches;
 h = thickness of plate in inches.

When one or more of the plates are rolled or are otherwise

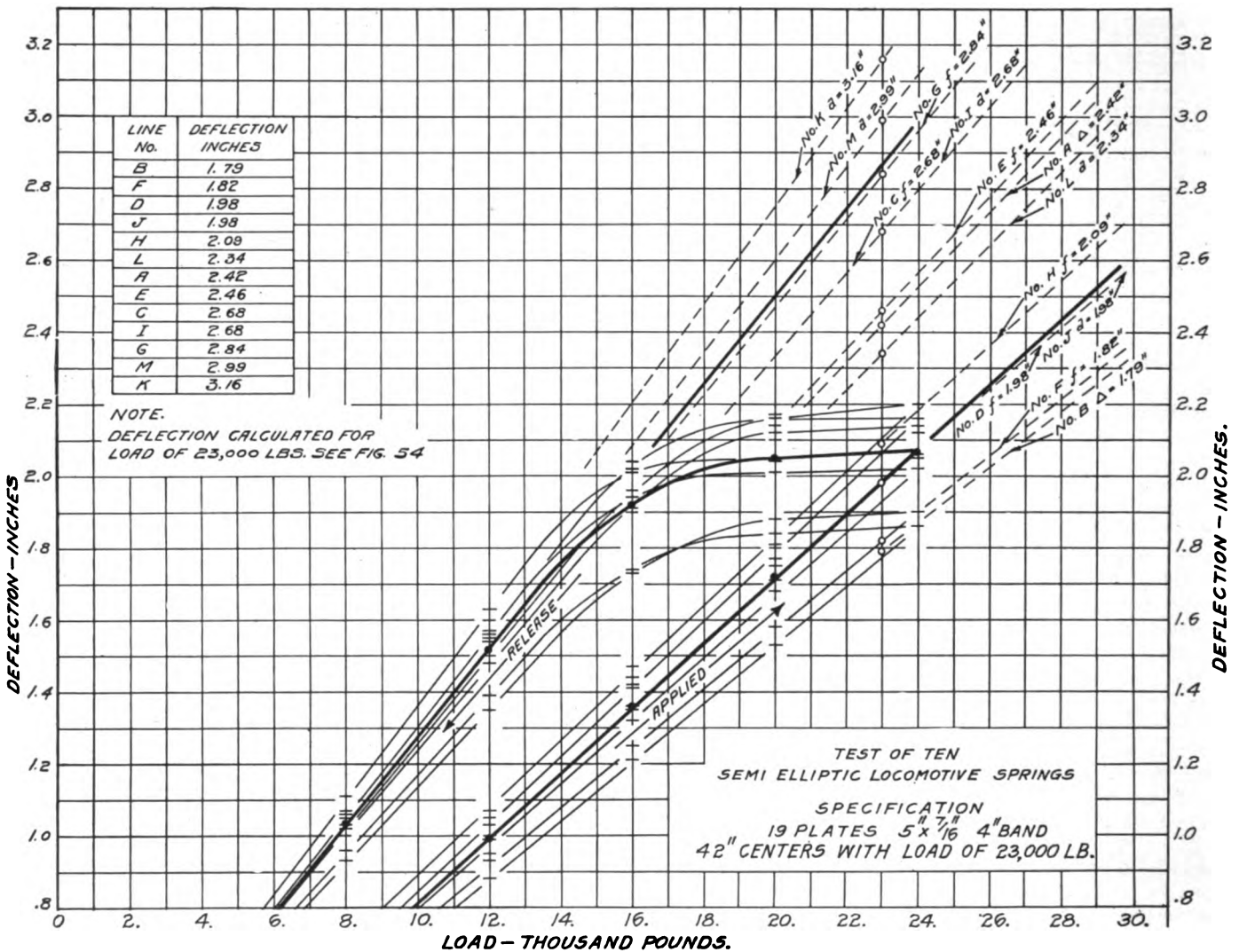

Fig. 22

the planes of the shearing stresses, one being a tensile stress and the other a compressive stress. Assuming that the tensile and compressive stresses, due to bending in one plate of each of the springs under discussion, is 80,000 lb. per sq. in., a value quite generally used in designing springs, and considering the maximum vertical shearing stress to be 8,900 lb., which is the value for the smaller plate, the maximum principal stress becomes :

$$S_t = \frac{1}{2}S_s + \sqrt{S_s^2 + 4S_s^2}$$

in which S_t = unit stress in tension;
 S_s = unit stress in shear.

In this case the maximum principal stress becomes 80,980 lb.

different in section, either b or h or both may vary considerably from their values for the plate of full section. This is of importance in dealing with old springs, since the decrease in thickness due to resetting and oxidation of a plate originally $\frac{3}{8}$ in. thick may amount to as much as $\frac{1}{32}$ in. or a decrease of 8.3 per cent. Since the strength of a plate varies directly as the square of its thickness the corresponding decrease in strength would be equal to 15.92 per cent., or practically 16 per cent. Should each of the $\frac{3}{8}$ in. plates composing a spring lose $\frac{1}{32}$ in. in thickness, the strength of the spring as a whole would thus be 16 per cent. less than before.

Since the deflection varies inversely as the cube of the thickness of the plate, the corresponding increase in deflection for a reduction of 1/32 in. in the thickness of the plate would amount to no less than 22.89 per cent. Were all the plates to suffer a similar reduction in thickness, the deflection of the entire spring would therefore be increased approximately 23 per cent.

Any reduction in the width of the plate would, of course, also affect its strength and deflection, but to a very much less degree, since these properties vary directly as its width.

In this discussion we have adhered to the straight beam theory.

DEFLECTION FORMULAS FOR SEMI-ELLIPTIC SPRINGS									
NO.	AUTHORITY	FORMULA FOR DEFLECTION	LOAD	SPAN	E, MODULUS OF ELASTICITY	WIDTH OF PLATES	THICKNESS OF PLATES	NUMBER OF PLATES	WIDTH OF BAND
A	D. H. CLARK	$\Delta = \frac{166L^3}{81\pi}$	SEE NOTE	L	—	b	t	n	—
B	DITTO (BAND DEDUCTED)	$\Delta = \frac{166(L-w)^3}{81\pi}$	SEE NOTE	L	—	b	t	n	w
C	MEHLERIX	$f = \frac{6P^2}{E16h^3}$	2P	2l	30,000,000	b	i	n	—
D	DITTO (BAND DEDUCTED)	$f = \frac{6P^2(1-w)^2}{E16h^3}$	2P	2l	30,000,000	b	i	n	w
E	S. R. MEMPHRESON	$f = \frac{5.5P^2}{E16h^3}$	2P	2l	30,000,000	b	h	n	—
F	DITTO (BAND DEDUCTED)	$f = \frac{5.5P^2(1-w)^2}{E16h^3}$	2P	2l	30,000,000	b	h	n	w
G	SAME AS NO. E. (MODULUS CHANGED)	$f = \frac{5.5P^2}{E16h^3}$	2P	2l	26,000,000	b	h	n	—
H	DITTO (BAND DEDUCTED)	$f = \frac{5.5P^2(1-w)^2}{E16h^3}$	2P	2l	26,000,000	b	h	n	w
I	MECHANICS FORMULA BOOK OF UNIFORM STRENGTH	$d = \frac{3P^2}{8Ebh^3}$	P	l	30,000,000	b	h	n	—
J	DITTO (BAND DEDUCTED)	$d = \frac{3P^2(1-w)^2}{8Ebh^3}$	P	l	30,000,000	b	h	n	w
K	SAME AS NO. I. (MODULUS CHANGED)	$d = \frac{3P^2}{8Ebh^3}$	P	l	26,400,000	b	h	n	—
L	DITTO (BAND DEDUCTED)	$d = \frac{3P^2(1-w)^2}{8Ebh^3}$	P	l	26,400,000	b	h	n	w
M	PROPOSED FORMULA	$d = \frac{P^2(1-w)^2}{53,000,000bh^3}$	P	L	—	b	h	n	w

NOTE: l IN SIXTEENTHS OF AN INCH, d IN SIXTEENTHS OF AN INCH PER TON (2240 LBS.) OF LOAD FOR A 1/2 PLATE 5" X 1/2" SPRING WITH BAND OF 23000 LBS. $\Delta = \frac{166L^3}{81\pi} = \frac{84.1L^3}{27\pi} = \frac{83000}{81\pi} = 36.768$ IN SIXTEENTHS OF AN INCH; l = .0625 = .625 INCHES. SEE FIG. 23 VALUES, UNLESS OTHERWISE NOTED, ARE IN POUNDS AND INCHES.

Fig. 23

While all the assumptions pertaining to it are not strictly true, they are sufficiently so for all practical purposes. Strictly speaking, springs as ordinarily built should be examined according to the formulas for the bending of curved bars, but the dimensions of the cross section of a plate being usually very small as compared with its length and radius of curvature, the ordinary beam formula will give the best approximations.

Neglecting the slight deflection due to vertical shear, the deflection at the center of a simple beam of uniform thickness and varying breadth, carrying a single load at the center and supported at each end is computed by the formula:

$$d = \frac{1}{8} \frac{PL^3}{EBh^3} \text{ where}$$

- d = deflection of spring, in inches.
- P = load on spring, in pounds.
- L = length of spring between supports, in inches.
- E = modulus of elasticity of material. For steel a modulus of 30,000,000 is ordinarily used, but this is sometimes altered in calculating springs to offset the effect of friction due to the sliding of the plates upon one another.
- B = total width, in inches at the center, = b x N where b = breadth of a single plate in inches, and, N = number of plates in a built-up spring.

Practically, however, the actual deflection obtained by testing such a beam will be somewhat less than that obtained by the formula, since it is necessary to move the supports in a short distance from either end, which reduces the span.

In the case of a plate spring additional variations are introduced. For instance, irregularities in fitting, such as variations in the openings between the plates, slight variations in the thickness of the different plates, and the condition of the bearing surfaces of the plates, especially at the ends, all affect the deflection of the spring. The almost universal custom of making from one-fifth to one-quarter of the total number of plates full length and the manner in which the ends of the remaining plates are rolled or tapered may also alter the deflection from that determined by formula. Finally, the effect of the band, by which the plates are held together, may be such as to decrease the effective span by an amount varying from zero to the full width of the band, which in railway practice may amount to from three to four inches. Another point which must be considered when

dealing with the deflection of a built-up spring is the lack of perfect elasticity, due mainly to the friction between the plates. This is to some extent a measure of the ability of the spring to dissipate shocks.

The variations that may exist in different springs of the same design are clearly illustrated in Fig. 22. The data reproduced in this figure was gathered from tests upon ten different springs of the same design, but built by different manufacturers. Although all the readings for the ten tests are shown in the figure, in some instances those of two or more springs coincided, which accounts for the fact that in some cases but seven or eight distinct points appear. For a similar reason but six distinct curves are plotted, these being shown in the light lines. After plotting the readings for the 10 tests these were averaged and are indicated by the full circles and the resulting curve drawn in with a heavy line. Since the static load for which these springs were designed was 23,000 lb. and the test loads only amounted to 24,000 lb. it was necessary to extend these curves by a comparison with a similar spring which had been tested under a greater load. These curves bring out at once the extent to which the values of the deflection as obtained from different springs of the same design vary from each other.

In order to show the variations in the deflection values obtained by using various spring formulas, those shown in Fig. 23 were applied to the spring referred to in Fig. 22. The results are shown by the broken lines in the upper part of the diagram and are tabulated for a load of 23,000 lb. That the deflection value will vary considerably according to the formula selected is clearly apparent and the designer is at once confronted with the perplexing question as to the proper formula to use.

Since there is very little information on record relative to the service deflection of railway plate springs, the author considers it inadvisable to attempt to base spring design on service deflection. In the preceding discussion attention has also been called to the fact that the value of the deflection as obtained from the applied load curve in testing is unreliable, since it depends upon a number of varying conditions. Generally speaking, the value obtained from the release load curve is much less affected by these conditions, and it will also be found to agree fairly well with the deflection of the spring in service. The height under service of passenger car bolster springs will be found to fall somewhere between the mean resultant of the applied and release load curves and the release load curve itself. In locomotive practice the service height of the spring will approximate very closely the release load height.

The release load curve is therefore considered the best basis upon which to develop a consistent formula for deflection. Combining the constant and the value of the modulus of elasticity in the formula for the deflection of a beam of uniform strength, it becomes:

$$d = \frac{P(1-w)^2}{80,000,000bh^3n}$$

in which w = width of the band.

Assuming that the values of P, l, w, b, h, and n, remain constant, it is clear that by substituting the average results of a large number of tests for the value of the deflection d, it is possible to determine the value of a constant a which, when substituted in the formula for the theoretical constant 80,000,000, will give results agreeing fairly closely with those of the actual tests. In this way the value of a has been found to be 53,000,000, which, on being substituted in the formula, increases the deflection 33.75 per cent. The formula in its final form is:

$$d = \frac{53,000,000bh^3n}{P(1-w)^2}$$

and is suitable for both semi-elliptic and full elliptic springs, the value obtained from the formula being doubled in the latter case. It will give satisfactory results not only for fully graduated springs having a minimum number of full length plates, but for those having one-quarter of the plates full length.

EXAMPLES OF RECENT LOCOMOTIVES OF THE ATLANTIC, TEN-WHEEL AMERICAN, MOGUL, AND SWITCHING TYPES

ARRANGED IN ORDER OF TOTAL WEIGHT

Table with columns for Type, Name of road, Road number or class, Builder, When built, and various technical specifications (Weight, Dimensions, etc.) for different locomotive models.

*Equivalent heating surface = total evaporative heating surface + 1.5 times the superheating surface. †Includes arch tube heating surface. ‡Boiler designed for 200 lb.

CAR DEPARTMENT

WELL CAR OF 200,000 LB. CAPACITY

The Pittsburgh & Lake Erie has in service two well cars of 200,000 lb. capacity and weighing 75,500 lb., designed for the distribution of the weight of the lading over a distance of 20 ft. at the center. The well opening is 27 ft. long by 7 ft. wide

similar sill is placed at a point intermediate between this sill and the outside plate of the side sill and both are connected by angles to the 7/16-in. web plate of the body bolster. A 3/8-in. top cover plate extends the full width of the car and is spliced by another 3/8-in. plate to the 1/2-in. bolster top cover plate, while a 5/8-in. plate is used at the bottom of the bolster and extends

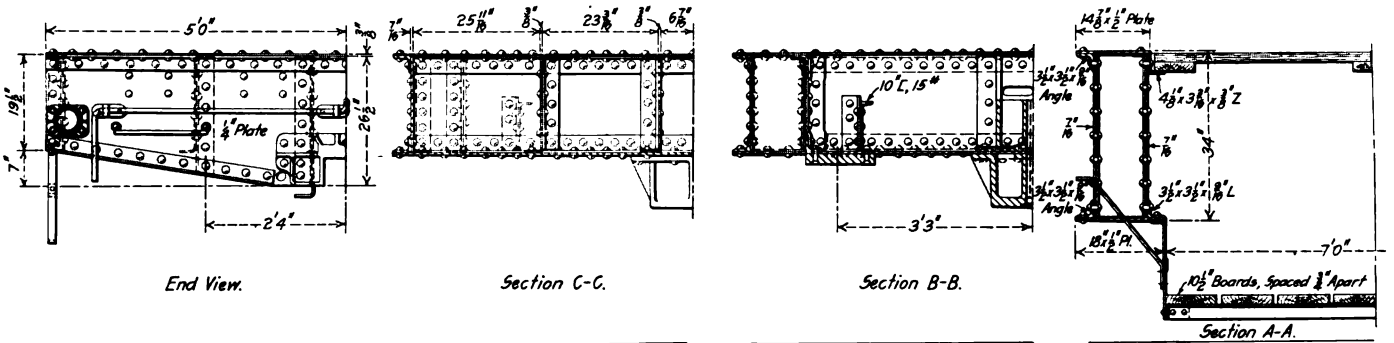

Cross Sections of the Well Car; the Letters Refer to the Elevation Drawing

and is provided with a removable decking made in six sections. The well or pit also has a guard or safety floor below.

Structural steel is used almost entirely in the construction of these cars. The end sill is built up of 1/4-in. plate reinforced with angles and is 26 1/2 in. deep at the striking casting. The

out at the center to the back end of the draft castings. The web plates of the body bolsters are placed 25 in. apart and a 10-in., 15-lb. channel connects them at the side bearings. The outer web plate extends completely across the car, while the inner one stops at the inner web plate of the side sill, to which it

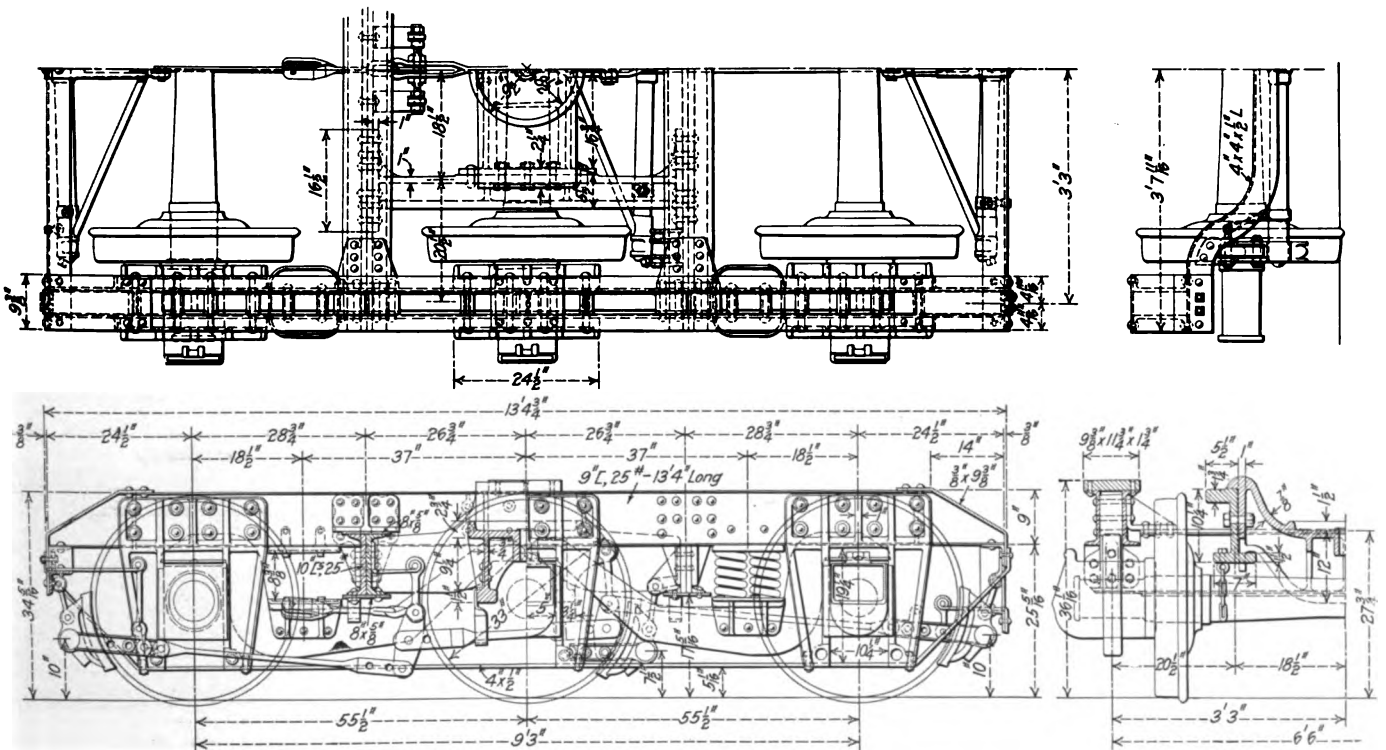

Arrangement of the Six-Wheel Truck for the Pittsburgh & Lake Erie Well Car

center of the body bolster is 7 ft. 2 in. from the end of the car and the draft castings are connected to 3/8-in. plate sills placed 6 7/16 in. on either side of the centerline of the car and extending between the end sill plate and the body bolster. A

is connected by a 3 1/2 in. by 3 1/2 in. by 9/16 in. angle, a 1/2 in. pressed filler being placed at this point between the two web plates of the side sill.

The side sills are of the fishbelly type, 20 1/2 in. deep at the

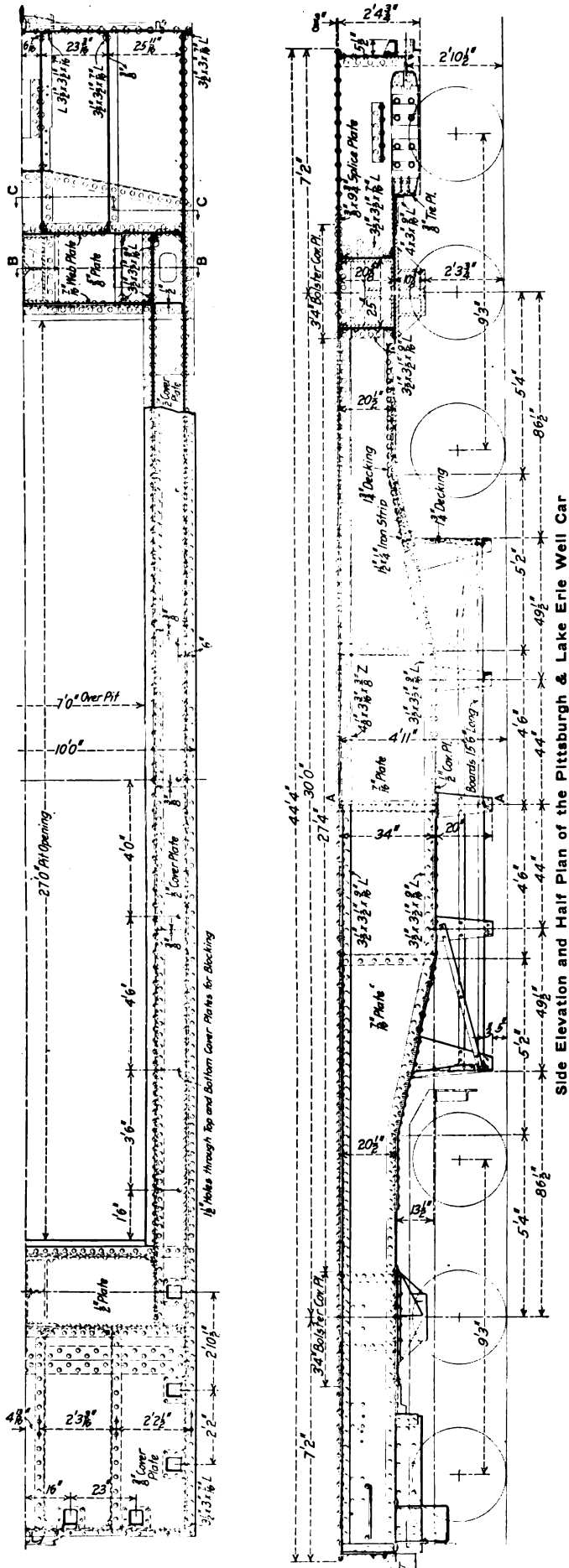

bolsters and 34 in. deep at the center. They are built up of two 7/16-in. web plates, the outer one of which extends the full length of the car, while the inner extends between the outer web plates of the body bolsters. The side sill web plates are connected to top and bottom cover plates by 3½ in. by 3½ in. by 9/16 in. angles, while a 4½ in. by 3 3/16 in. by ¾ in. Z-bar is riveted to

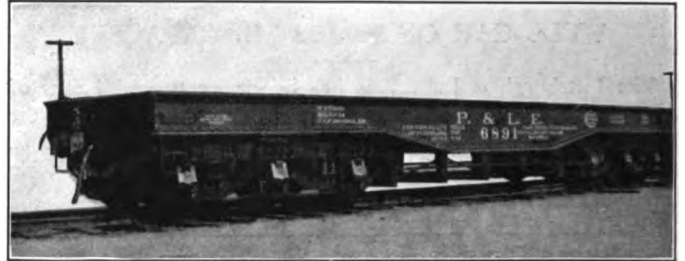

Pittsburgh & Lake Erie Well Car

them on the upper side for the length of the well to support the decking. The top cover plate is 14 7/8 in. by ½ in. by 27 ft. 4 in. long, while the bottom one is 18 in. by ½ in. and extends between points somewhat short of the body bolsters.

The cars are 44 ft. long over the deck and the trucks are spaced 30 ft. between centers. The trucks are of the six-wheel

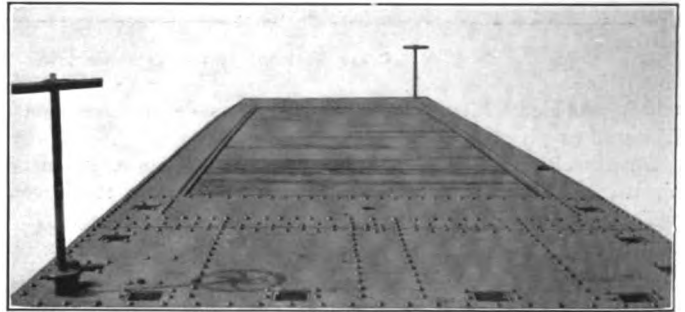

Top View of the Well Car

type, with a wheelbase of 9 ft. 3 in., the bolsters and pedestals being of cast steel, while the frames are of structural steel, the side members being 9-in., 25-lb. channels. The trucks are equalized and forged steel wheels are used, mounted on axles with 6 in. by 11 in. M. C. B. journals. Each end of the car is equipped

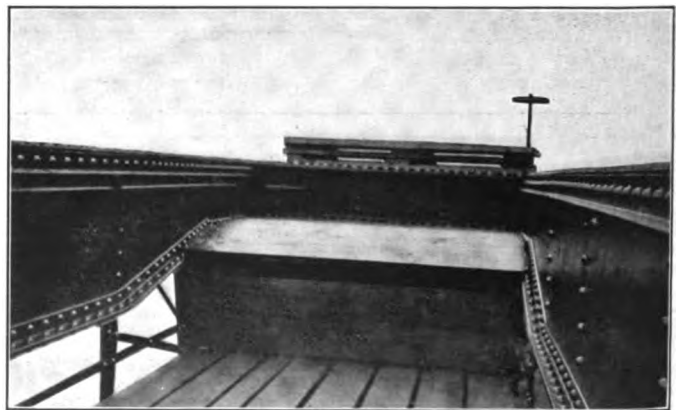

View Showing the Interior of the Well

with its own braking apparatus, both hand and air operated. The body center plates, body bolster fillers, and the striking plates are of cast steel. The safety floor is of light construction and is so arranged that it can be removed in case the lading is of such a nature that extreme depth is required.

TESTING CAR ROOFS

At a recent meeting of the Car Foremen's Association of Chicago, F. C. Maegly, assistant general freight agent of the Atchison, Topeka & Santa Fe, mentioned a spraying device



Testing Car Roofs for Leakage at the Topeka Shops of the Atchison, Topeka and Santa Fe

used at the Topeka shops for the purpose of testing the roofs of cars for leakage. The construction of this device was briefly described in the *Railway Age Gazette, Mechanical Edition*, of July, 1914, on page 374. The accompanying illustration shows

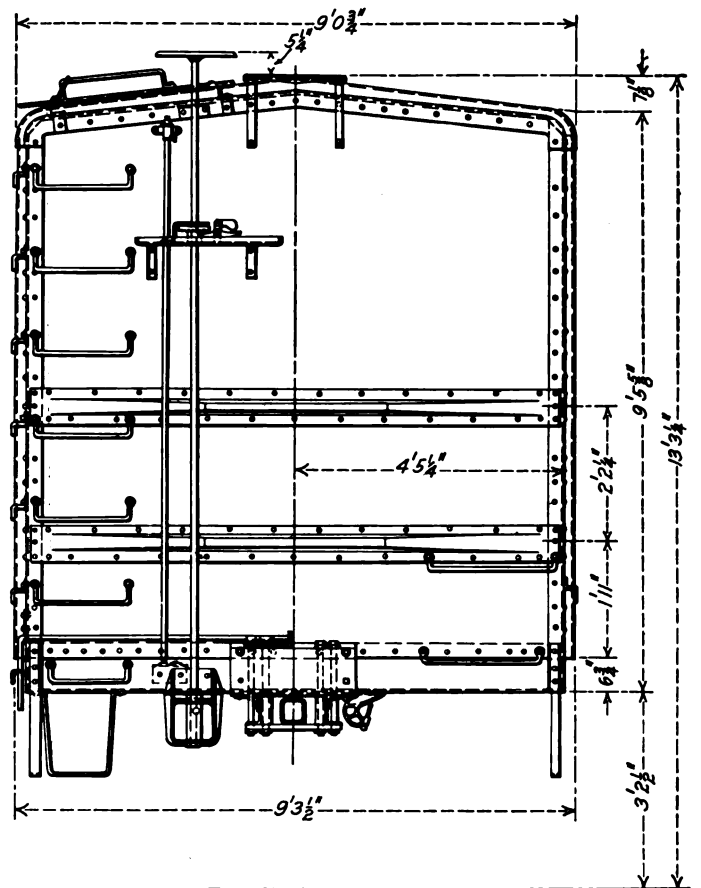
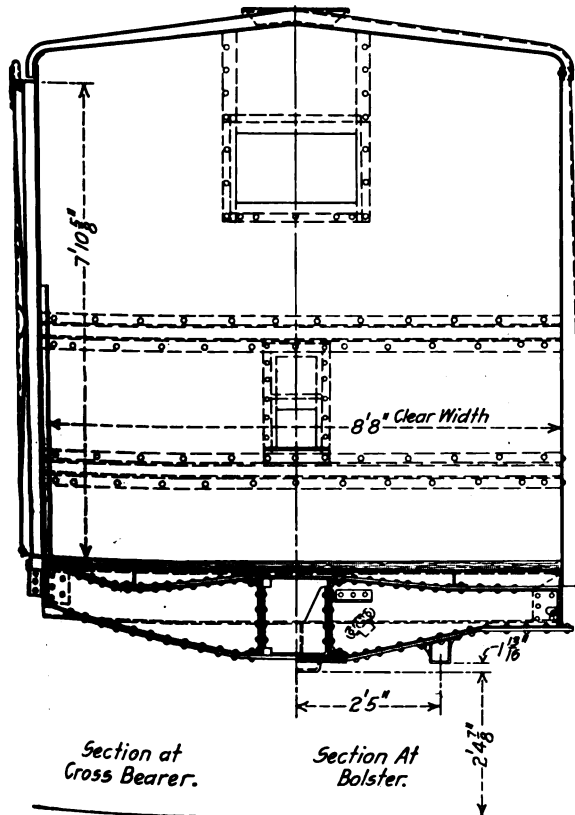

Cross Sections and End Elevations of Canadian Pacific All-Steel Box Car

the device in operation, the house from which the device is controlled is shown in the foreground. The method followed at Topeka is to haul the cars to be tested under the spray twice, with all the doors closed. After this the inspectors enter the cars and distinctly chalk all the leaks so that the foreman and the repair men in the shops will know what repairs are necessary. After the cars have been repaired and painted they are again placed under the spray, and any leaks that may have been overlooked by the repair men are repaired before the car is allowed to go. The volume of water is so great that it is possible to discover leaks in the side sheathing or the ends of the car. This device was originated by Charles M. Swanson, superintendent of car shops, Atchison, Topeka & Santa Fe at Topeka, Kan.

ALL-STEEL BOX CAR

An all-steel box car recently designed and built by the Canadian Car & Foundry Company, Montreal, Que., and now in service on the Canadian Pacific, is shown in the accompanying engravings. The car weighs 37,000 lb. and has an inside length of 36 ft. with a clear inside width of 8 ft. 8 in.

The construction of the car body is such that the interior surface is smooth, there being no braces employed in the side and end frames. The side posts are formed by pressing one vertical edge of each side sheet into a U section and are spaced 2 ft. 6 7/8 in. between centers. The portion of the side sheets forming these posts is also offset to lap over the flat edge of the adjoining plate. A similar construction is employed in forming the roof members, the pressed U section in the roof sheets being made to correspond and to lap over the side sheets, thus practically forming a continuous post from side sill to side sill. As shown in the illustrations, these combined posts and carlines are on the exterior of the car, leaving a smooth interior which

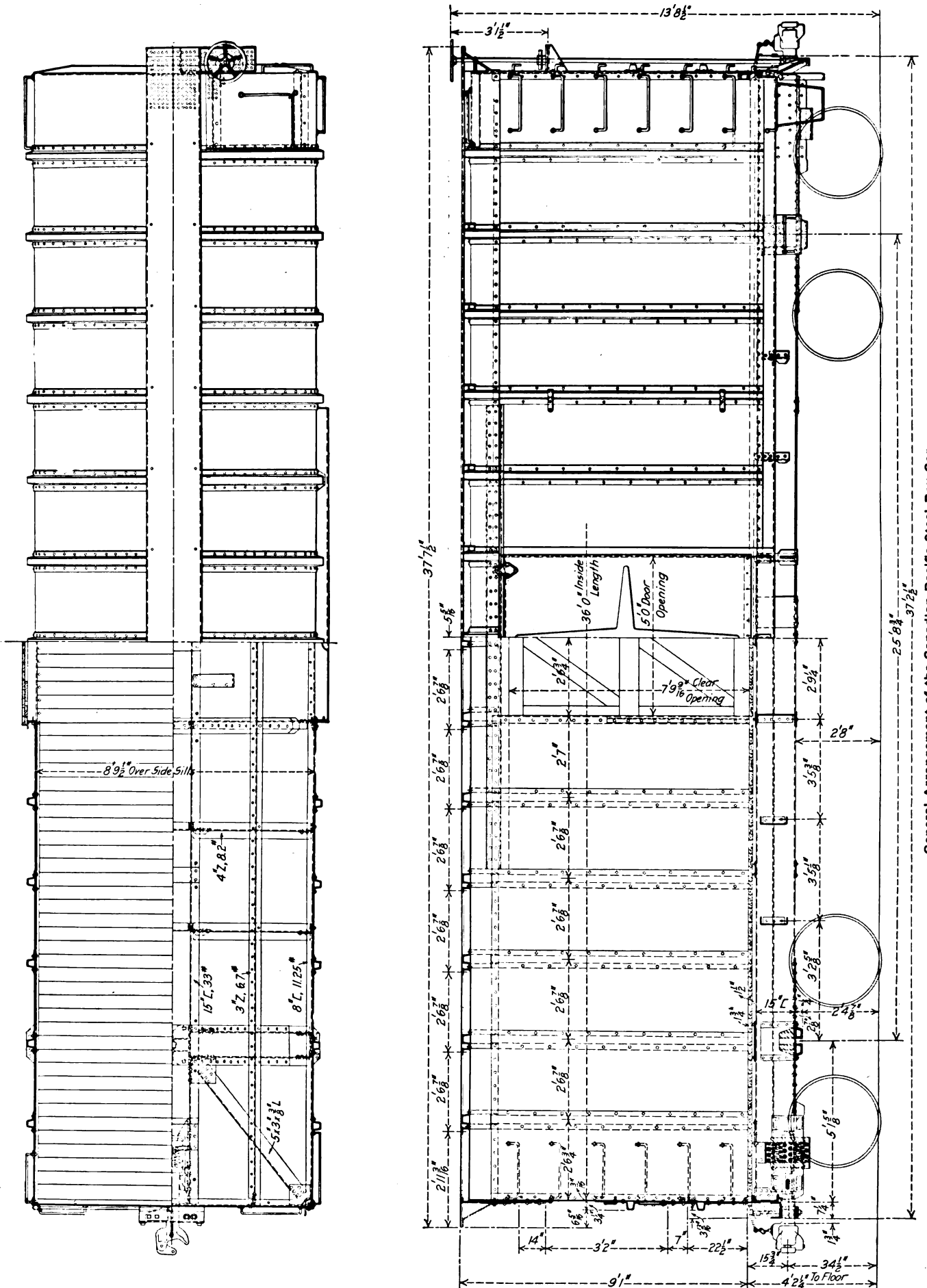

General Arrangement of the Canadian Pacific Steel Box Car

helps increase the loading space and makes the car easy to clean. The side plates are 3/16 in. thick and the roof plates are 1/8 in. thick, while the end plates are 3/16 in. thick and are reinforced by horizontal stiffeners of U-shaped section. Two sliding doors are provided in one end of the car to facilitate the loading of lumber and other long material. The running board is supported on angles riveted to the roof sheet.

The car is 37 ft. 2 1/2 in. long over the buffer blocks on the end sills and the distance between center plates is 25 ft. 8 3/4 in. The center sills are 15-in., 33-lb. channels, which are connected by channel-section distance pieces, spaced at 3 ft. 5 1/8 in. intervals, and by plates at various points throughout the length of the car, there being no cover plates employed except on the under side for a short distance at the body bolsters. The body bolsters are built up of 1/4 in. pressed steel webs or fillers with 1/2 in. top cover plates and 1/2 in. bottom cover plates. There are two cross-bearers placed 2 ft. 9 1/4 in. on either side of the center line of the car and built up of 1/4 in. pressed fillers 1/2 in. top cover plates and 1/2 in. bottom cover plates. The side sills are 8-in. 11.25-lb. channels and there are 5 in. by 3 in. by 3/8 in. diagonal bracing angles at the ends of the car, between the junction of the side and end sills at the corner of the car and the junction of the body bolster and the center sills. The center and the side sills are connected by 4-in., 8.2-lb. Z-bars and these support a 3-in., 6.7-lb. Z-bar placed about midway between the side and the center sills on both sides of the car, which acts as a floor stringer. The end sills are built up of steel plates and angles.

The drawings show provision for a steel door, but a wooden door was used on the car as shown in the photograph. The capacity of the car is 80,000 lb.

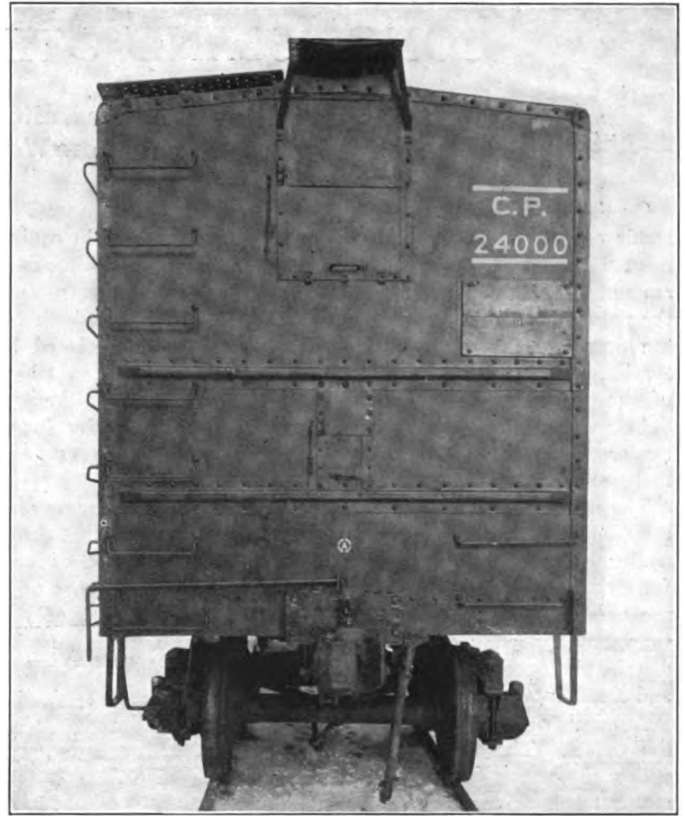

End View of the Canadian Pacific Car

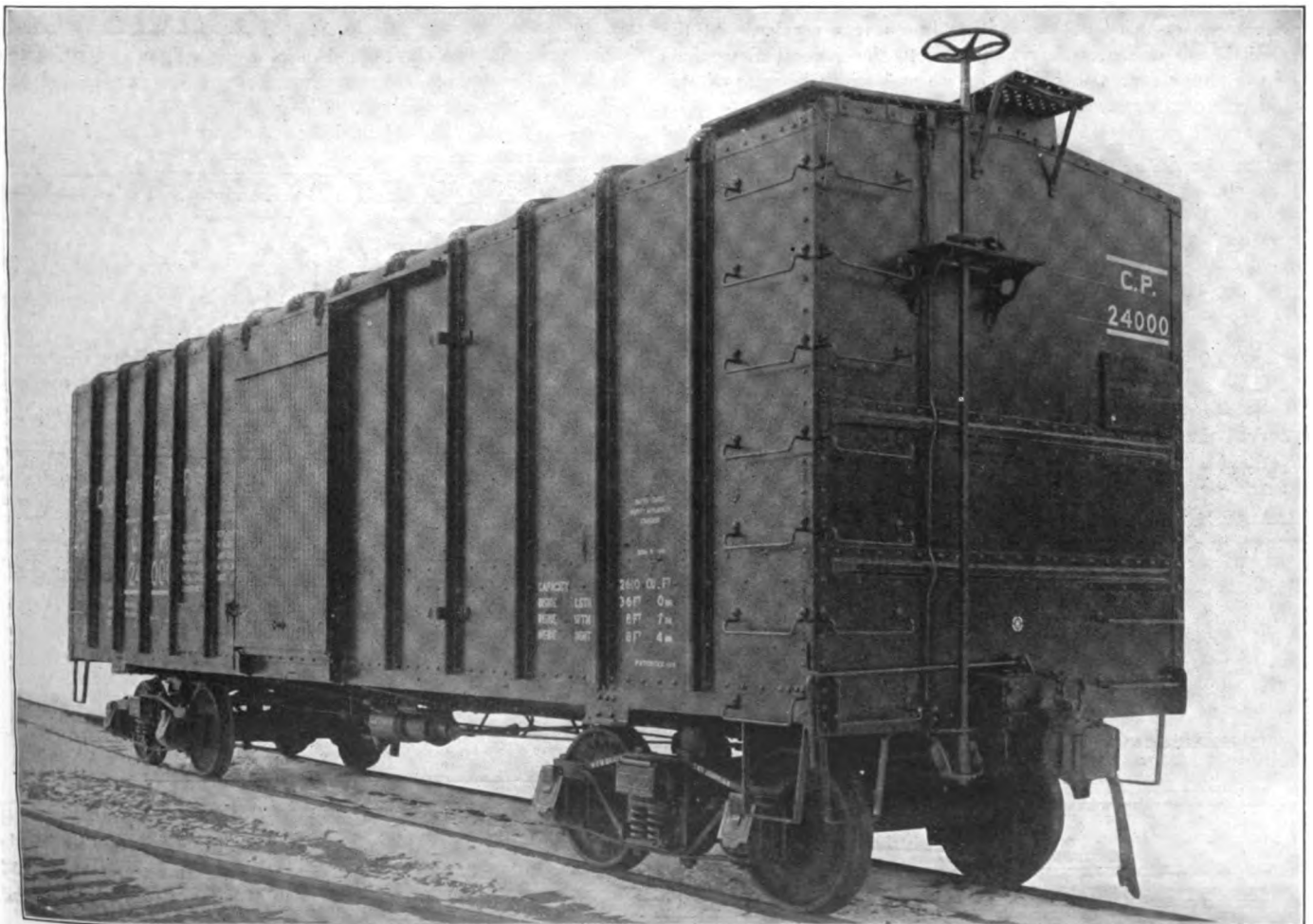

Steel Box Car Built for the Canadian Pacific by the Canadian Car & Foundry Company

LONG ISLAND STEEL SUBURBAN CARS

Unlined Trailers Built for Summer Service Only; Exceptionally Low Weight per Seated Passenger

On the electrified lines of the Long Island Railroad, passenger traffic conditions are such that a considerable increase in equipment is required during the summer months. This increase amounts to about 25 per cent of the equipment in service during the remainder of the year. An order of 20 trailer cars, built by the Standard Steel Car Company, has recently been placed in service, in the design of which full advantage has been taken of these conditions not only to produce a car of exceptionally light weight, but to secure a maximum carrying capacity for a moderate outlay and to reduce to a minimum the investment tied up in idle equipment during the winter months.

The use of trailers was decided upon after a general survey of the traffic and operating conditions, it being estimated that three trailer cars could be built for approximately the cost of one fully equipped motor car. Furthermore, where motor cars only are used, if the conditions are such that during a part of the year only a portion of the cars are needed, the service must be distributed over all the cars to provide for proper inspection and maintenance of the electrical equipment.

A number of restrictions were imposed upon the design at the outset. The Long Island's class MP-54 motor cars with which the trailers are to operate are each equipped with one motor truck driven by two Westinghouse No. 308 motors, having a normal rated capacity of 225 hp. each. It was required that the weight of the trailers should be such that the operation of one trailer car with three motor cars would be well within the capacity of the motors in express service. At the same time it was necessary to adhere to the general dimensions of the motor car as to height, length and width because of station platform requirements and to preserve the uniform general appearance of the train. The strength of the underframe and

heating, and a car has been built which has a seating capacity of 80 with a total weight of 63,000 lb., which is only 787½ lb. per

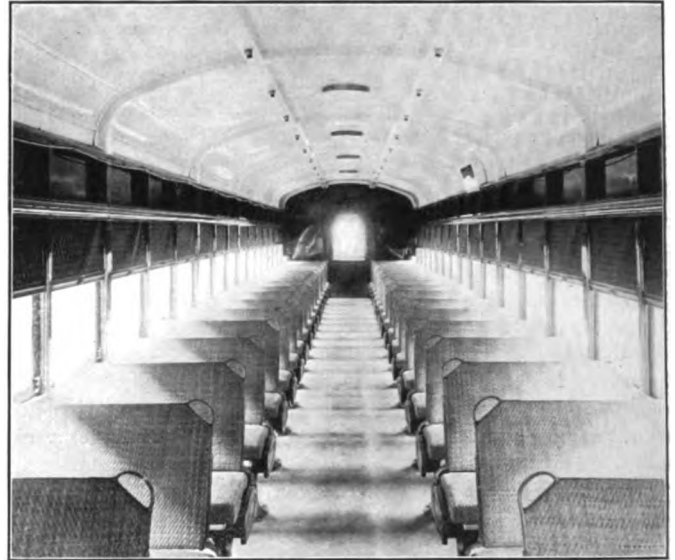

Interior of the Long Island Steel Trailer

seated passenger; a class MP-54 motor car weighs approximately 110,000 lb. and seats 71 passengers, the weight per seated passenger being about 1,550 lb.

The cars are 64 ft., 5¼ in. long from face to face of couplers.



Steel Trailer Coach for the Long Island

body was required to be at least equivalent to the strength of the standard motor cars with which they are to operate. Owing to the fact that additional equipment was needed for summer service only, it was feasible to reduce the weight and cost by the omission of the false floor, inside lining and provision for

The over-all width is 9 ft., 10¾ in., and the omission of lining and insulation has made possible an inside width of 9 ft., 9¾ in. between posts with a clear width at the posts of 9 ft., 4½ in. An unusually wide aisle has thus been provided. The trucks are placed 39 ft., 9 in. between centers and the car has a total

tibule purlines of the same section as those used in the interior of the car are placed between the vestibule end posts and the body end posts, and the vestibule is further stiffened longitudinally by increasing the thickness of the roof sheets from 3/32 in. to 1/8 in.

The length of the car body is 54 ft. 9 3/4 in. over the corner posts, and each side frame is divided into five side and two corner panels, the former being 8 ft. 6 in. long from center to center of carline posts, and the latter 5 ft. 10 7/8 in. from the centerline

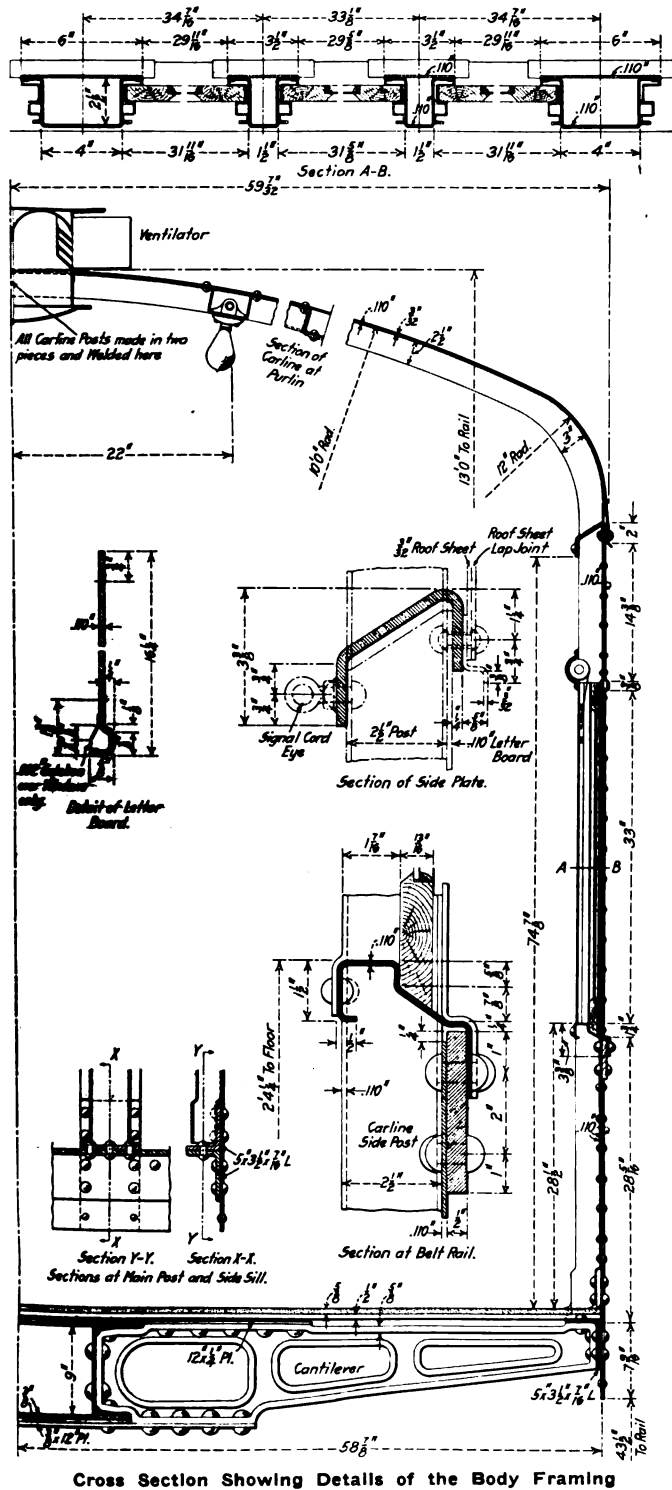

Cross Section Showing Details of the Body Framing

of the carline posts to the inside of the body corner posts. Each of the side panels contains three windows, which are separated by vertical members of U-section extending from the side plate to the belt rail. The corner panels each contain one window, framed by the carline post on one side and on the other by a

U-section post extending from the side sill to the plate. A pressed steel window sill is attached to the carline posts and forms the bottom attachment for the vertical members between the windows in the side panels. It is flanged over the top of the belt rail and is riveted through to the side of the car. The belt rail

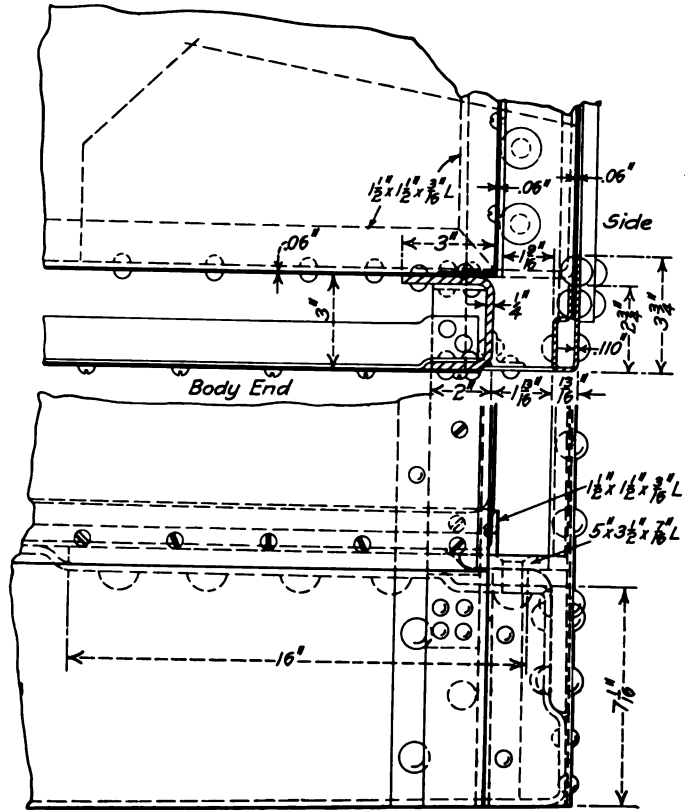

Connection of Body Corner Post and Body End Sill

is of rectangular section 1/2 in. thick by 4 in. wide and extends from body corner post to body corner post. The side plate is a special pressed steel U-section extending throughout the length of the car body. The web and outside flange are cut away at the side posts and the inside flange is riveted to the posts. The outside flange extends over the top of the letter board and is riveted between this and the lower edge of the roof sheets.

All framed members have been formed to produce a finished appearance on the interior of the car, and no interior finish

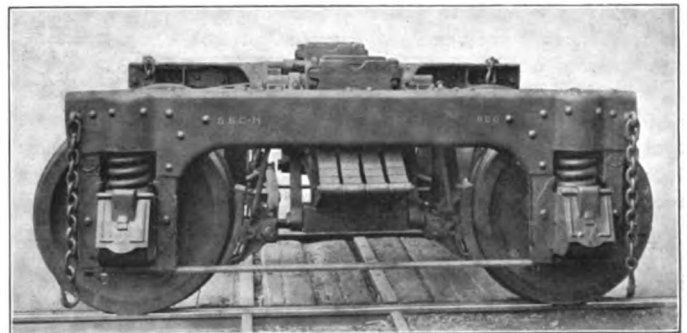

Four-Wheel Truck for Long Island Steel Trailers

has been used, with the exception of the pressed steel molding which covers the curtain rollers just above the tops of the windows.

TRUCKS

The cars are equipped with four-wheel trucks having a wheel base of 6 ft. 4 in. These trucks are of an unusually simple design and weigh 9,400 lb. each, complete. The general features of the construction are clearly shown in the illustrations. The side

frames and transoms are of pressed steel, while the bolster and spring plank are steel castings. By widening the flanges of the transoms at the ends and providing corresponding lateral extensions from the top side frame flanges, a very rigid transom and side frame connection has been secured and end rails are dispensed with. Steel pedestal castings provided with coil spring pockets are riveted to the ends of the side frames, which are specially formed to receive them. The truck is equipped with a light cast steel spring plank, which is suspended by swing links pivoted on the top of the cross frame. Both the bolster guides and the pedestals are fitted with wearing plates, which may be easily removed and replaced. The trucks are equipped with rolled steel wheels 33 in. in diameter, which are mounted on axles with $4\frac{1}{4}$ in. by 8 in. journals. Ajax metal bearings are used.

FINISH

The floor is finished with the railroad's standard top coated monolith laid in Ferro-inclave sheets. No false floor is provided.

The exterior of the cars is painted Tuscan red to conform to the Long Island's standard for passenger equipment. The interior is finished in white and light olive green, white enamel being used above the side plates and the olive green from the side plates to

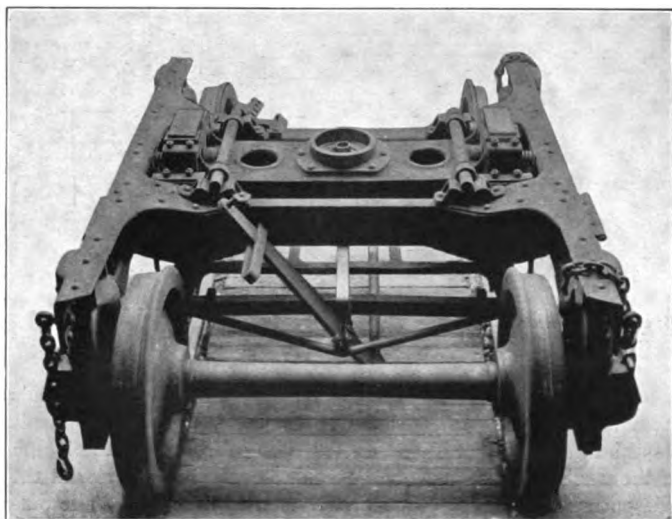

Another View of the Truck

the floor. The seats are rattan covered and have no arms. They were furnished by Heywood Brothers & Wakefield Company, and are low enough to make possible the elimination of foot rests. The cars are ventilated by five Automatic ventilators set into the roof on the centerline of the car.

Since the cars are trailers no provision has been made in the vestibule for train control. The cars are provided with bus and control lines, however, for attachment to adjoining cars when operated in multiple unit trains. Current for lighting the cars is taken from the bus line.

In making up trains where detachable jumpers are used, considerable delay is often caused by the failure to find the proper jumpers at hand. In order to overcome this difficulty the jumpers are integral parts of the wiring of these cars and dummy receptacles are provided for holding the jumper head when not in use. This feature is shown in the illustration of the car end.

DESIGN OF STEAM PIPING.—Correctly designed steam lines skillfully erected are no more likely to fail and interrupt the service than other features, not duplicated. It is a matter of common experience that the hydraulic piping in a plant causes less trouble than the low-pressure house-service piping, because of the difference in installation. The same is applicable to steam piping.—*Power.*

INSPECTION AND MAINTENANCE OF AIR BRAKES ON FREIGHT CARS*

By ROBERT BARNABY

When a triple valve is removed from a foreign car for the necessary cleaning, lubricating, and repairs, the repairman removing the valve should sign and insert in the check valve case a card, noting thereon the initial and number of the car, the date and place removed, the make and type of triple valve, the initial of road, the date of last previous cleaning, and why sent to the shop. In addition to this the check valve case should be marked with red paint as a designating mark that this is a triple valve from a foreign car. This will insure prompt repairs.

The triple valve should then be forwarded without delay to the nearest test rack. Upon receipt of the valve at the test rack, the workman handling it will note that it is from a foreign car and he will remove the card from the check case and note thereon the work he performs and all material used in making repairs at the test rack or shop. After the repairs are completed, the slip that has traveled with the triple valve must be promptly forwarded to the office of the foreman holding the record of the other repairs performed on the car. This will enable him to prepare the necessary M. C. B. billing repair card, which will include all items of repairs shown on the slip. If the complete repairs cannot be made within a reasonable time, it is, of course, permissible to make up a repair card covering the cleaning, lubricating and testing of the cylinder; also the cleaning, lubricating and testing of the triple valve, and place a notation on the repair card, "Bill for repairs to follow," which means that an additional repair card can be made up covering the same car after a list of the repairs made to the triple valve are furnished to the foreman who has made out the first repair card.

The opening of the brake cylinder expander ring, when put in the cylinder, should be at the top and also that portion of the packing leather that was at the bottom should be turned to the top of the cylinder. The opening in the expander ring should not be less than $\frac{1}{4}$ -in. or greater than $\frac{3}{8}$ -in., and the ring should have the ends properly rounded. A light coat of brake cylinder compound should be applied to the walls of the cylinder and packing leather with a suitable brush. The cylinder should not show a leakage of more than 5 lb. per minute with an initial brake cylinder pressure of 50 lb. Whenever cars are tested on shop or repair tracks, the brake cylinder must be tested and leakage reduced to 5 lb. per minute. This test should be made with a gage applied to the exhaust port of the triple valve in release position. All cars on shop, warehouse or teaming tracks should be tested regardless of the stenciling shown on the cylinder. No sharp tools should be used to help enter packing leathers in brake cylinder.

It is absolutely necessary to have the retaining valve, its pipe and connections, absolutely tight; if such is not the case, the particular car will not do its proportionate share of braking descending a grade, or when the retaining valve is supposed to be operated. No matter how tight a packing leather is, it is of no use if the retaining valve and its connections are not in good condition; on the other hand, if the retaining valve and all of its connections are in good condition, the retaining valve will give no service whatever if the packing leather is defective.

The car inspectors and repairmen whose duty it is to inspect and make light repairs to brakes and draft arrangements should also be required to give the same attention to hand brake defects, adjustment of brake rigging, brake pipe hangers, angle cocks, hose and couplings and pipe connections. The repairs should be made at the same time that other defects receive attention.

*From a paper read before the Niagara Frontier Car Men's Association, Buffalo, N. Y., May 19, 1915.

SHOP PRACTICE

OIL BURNING SAND DRYER

By F. G. LISTER

Mechanical Engineer, Spokane, Portland & Seattle, Portland, Ore.

A sand dryer which is very inexpensive to build and which is giving excellent results is being used by the Spokane, Portland

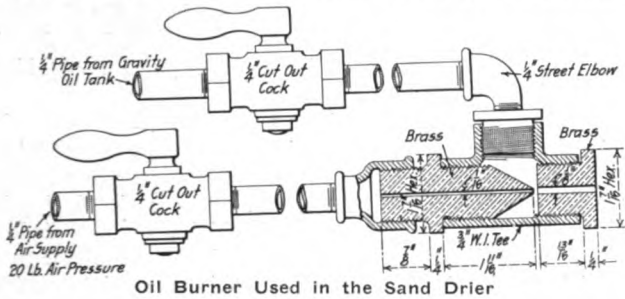

Oil Burner Used in the Sand Drier

& Seattle at its shops in Vancouver, Wash. Oil is used for fuel, and is a great improvement over coal or coke in that a steady heat can be maintained and regulated to suit the con-

a pressure of 20 lb. About four hours per day are consumed by the operator in handling the dryer and sanding on an average of twelve engines. The remainder of his time is spent in helping the hostler turn engines, etc. The dryer was designed and

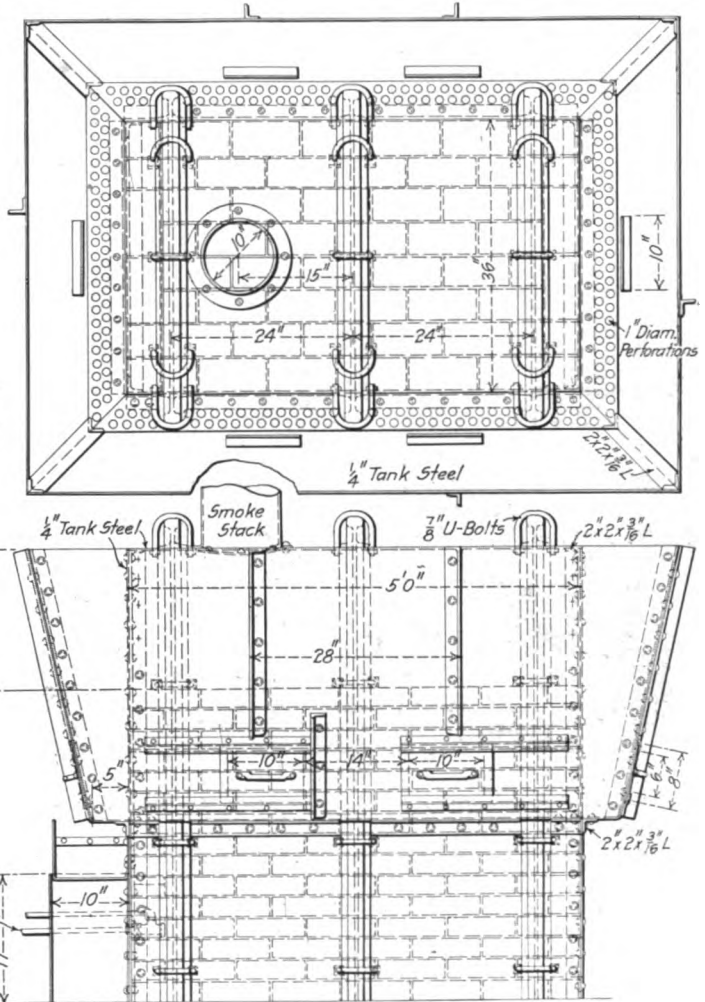

Steel Sand Drier Which Uses Fuel Oil

ditions, and in structure has outlived three of the ordinary cast iron type.

The dryer is built with a frame work of three light rails lined on the inside with 1/4-in. tank steel. The walls and bottom are lined with one layer of fire brick to a height 42 in. above the floor line. The hopper is made of 1/4-in. tank steel joined at the corners with 2-in. by 2-in. angles, and the bottom is perforated with 1-in. round holes to allow the dry sand to run out. The sides and ends are provided with openings covered with sliding doors for the purpose of loosening the sand if packed, or to remove stones which might be lodged inside. The chimney is located in the front of the arch; the flame blowing in at the front door strikes the back wall and causes the gases to return to the front of the box and out the chimney, thus completely utilizing the heating surface of the firebox. The burner is made of standard pipe fittings, except the nozzle and two reducers which are made of stick brass.

The dryer is operated eight hours per day, three hoppers of sand being dried in this length of time. Eight gallons of fuel oil are consumed for each hopper full of sand. Air is supplied at

built by C. A. Landberg, general foreman of the Vancouver, Wash., shops of this company.

MANUFACTURING BROOMS

By B. N. LEWIS

Inspector, Shoreham Shops, Minneapolis, St. Paul & Sault Sainte Marie

Among the problems met in providing supplies for a railroad is that of securing brooms of a quality entirely suitable for the various uses to which they may be put. In order to provide better brooms their manufacture has been undertaken at the Shoreham shops of the Soo Line, and has given excellent results.

One of the greatest defects in the brooms usually purchased is that the corn soon becomes loosened from the handle, the brooms thus being short-lived. This has been overcome by extending the handle into the corn about six inches and applying metal bands in addition to the usual sewing. Three classes of new brooms are being manufactured. The common broom

shown at *A* in the illustration is used for ordinary sweeping. It carries only one steel band and is twine sewed. The band is squeezed into place in the sewing press and an eightpenny nail driven through it into the handle. It is then sewed with No. 12 gauge wire, passing through the band and the corn as shown in the illustration. The engine broom shown at *B* is especially designed to meet the requirements of the extra heavy service to which it is subjected. It is provided with two steel bands and no twine sewing is used; a bamboo insert is woven in with the corn when binding. This has proven a very serviceable adjunct. The switch broom is shown at *C*. Brooms of this type are made from reclaimed material returned to the shop, the worn end of the corn being cut off. This gives better service for track use than would new material.

The whisk broom shown at *D* is manufactured very cheaply by saving out the finest of the corn when sorting material for the manufacture of the other brooms. This saves purchasing a special quality of high priced corn sold for brooms of this kind.



(A) (B) (C) (D)
Brooms Manufactured in the Shoreham Shops of the Soo Line

Brooms are being made at a saving of the following amounts as compared with the market prices previously paid: common, five cents; engine, four cents; whisk, five cents. To secure a new broom the old one must be turned in. The handles of the old brooms are then reclaimed at a cost of \$7.50 per thousand, which is less than one-third the price paid for new material. These handles are used in making engine brooms. The greatest saving is effected, however, by the increased service obtained from the brooms of our own manufacture. Their life is approximately double that of the brooms previously purchased in the market, this statement being based upon the decrease in the number issued.

This work is handled directly by the stores department; one man working on a contract basis furnishes all that are required by the road. The equipment required is inexpensive and consists of the following: winder, press, scrapper, drain board, tub and a cutting and sorting table fitted with a knife. The idea originated in the weekly shop foremen's meetings.

PERIPHERAL SPEEDS.—As compared with the 38 ft. per sec., which is considered the limit in safe speed for a cast-iron flywheel, some of the peripheral speeds attained by the disks of steam turbines are striking. In a paper presented to the Manchester Association of Engineers, R. F. Halliwell says: "The highest peripheral speed which it is possible to employ is probably found in the 300-h. p. DeLaval turbine, in which, with a 30 in. wheel running at 10,000 r. p. m., a velocity of over 1,300 ft. per sec. is reached."—*Power*.

OILING AIR PUMP AIR CYLINDERS

By E. A. MURRAY

Master Mechanic, Chesapeake & Ohio, Clifton Forge, Va.

The accompanying drawing shows a method of applying oil cups to the air cylinders of cross-compound air pumps which has a decided advantage over the usual application of these oil cups. The arrangement was developed by R. J. Bursey, air brake foreman at this point, and consists of the standard Westinghouse oil cup with a ball check placed in the pipe leading to the cylinder. The purpose of the ball check is to prevent back pressure from entering the oil cups. This makes it possible to oil the air cylinders at all times even though the pump has leaky discharge valves or worn packing rings. It saves a great deal of oil and has resulted in practically eliminating the practice of oiling pumps through the air strainer.

This arrangement has been in use for some time on the air cylinders of both cross-compound and 9½ in. pumps, and has given excellent service. As applied to the low-pressure cylinders of the cross-compound pump, the check valve is placed directly below the oil cup. In applying to the high-pressure cylinders the check valve is placed as near the cylinder end of the pipe as possible. It has been found that there is but a slight suction at the oil pipe connection at the beginning of the down stroke

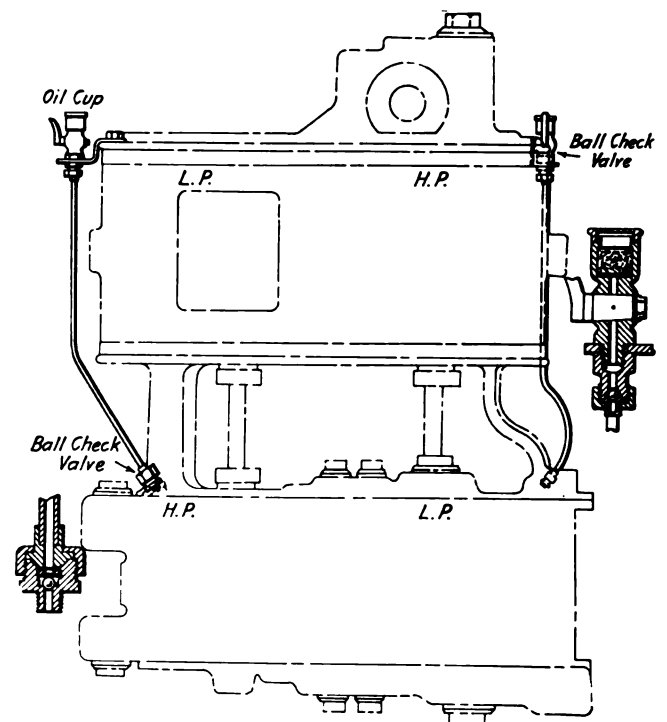

Ball Check Valve in Air Cylinder Oil Pipes of Cross-Compound Air Pump

of the high pressure piston and it was therefore necessary to provide for the accumulation of a small volume of oil between the oil cup and the check valve.

With this device the cost of air pump repairs has been materially decreased and the efficiency of the pumps has increased perceptibly.

BRITISH DINING CAR SERVICE.—It is stated that all the railway companies are likely shortly to withdraw their dining cars. It must also be remembered that dining cars are luxuries provided by the force of competition. As each car weighs at least forty tons and there are generally two cars on all the northern main lines, their withdrawal would lead to a considerable saving in coal and set free a large number of young men to join the colors.—*The Engineer*.

RAILWAY TOOL FOREMEN'S ASSOCIATION

Reports on Special Jigs, Safety Pneumatic Tools, Grinding and Standardization of Reamers

The seventh annual convention of the American Railway Tool Foremen's Association was held at the Hotel Sherman, Chicago, Ill., July 19 to 21, inclusive, Henry Otto, tool foreman, Atchison, Topeka & Santa Fe., Topeka, Kan., presiding. Prayer was offered by Rev. O. M. Caward. The address of welcome was made by Robert W. Bell, general superintendent of motive power, Illinois Central. An illustrated lecture on "Getting the Most Out of Tools," was presented by B. W. Benedict, director of shop laboratories, University of Illinois.

ADDRESS BY R. W. BELL

From my observations and what I have heard, I have come to the conclusion that you tool foremen come here with a determined intention of acquiring all possible knowledge per-

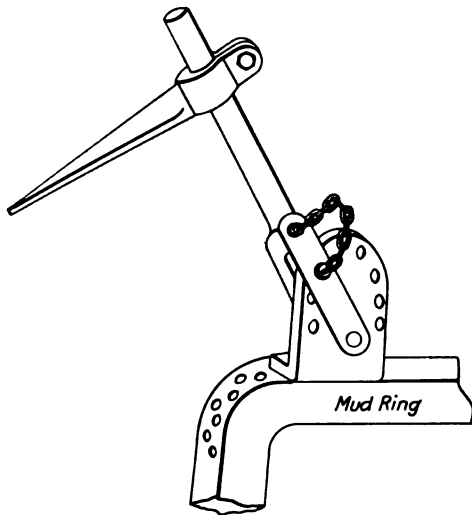

Fig. 1—Angle Drill Post Used on the Illinois Central

taining to your particular line of work. I realize that much good can be accomplished through an organization of this kind when the right motives prevail, and I am in hearty accord with the ideals for which you apparently are striving. Railroads are constantly facing new situations and dealing with new conditions. Progress demands the incessant interchange of opinions. We gain new inspiration and derive original viewpoints as often as we add to our acquaintances; therefore, the value and necessity of getting together and exchanging ideas. There is much to be accomplished in your line of work, and I am sure if you employ your faculties here at this convention you cannot fail to profit, and take home with you many valuable ideas, which will be of great benefit to you personally and to the road which you represent.

There can be no better plan for reducing shop costs than through efficient tool service, and it must be apparent to all that you tool foremen have a direct influence on the efficiency of the many workmen employed in your shops, who, if not supplied with good safe equipment to work with, are liable to waste much time, and in many cases, work under hazardous conditions. The importance of good tools in railroad shops was never before realized as it is today, and each year we find changes taking place in our locomotives and cars which demand that you be keenly alive to the situation, in order that repairs to such power and equipment may be quickly and properly handled. Some of you men, no doubt, are located at the smaller shops, where the making of tools is restricted, but I would impress on

your minds the importance and necessity of keeping up-to-date.

There are probably no greater possibilities in any line of railroad shop work than in standardizing good tools and appliances for the work, and it should be your object to make the best of the opportunities afforded in coming together for the discussion of such matters. Railroads are not selfish in the matter of new and improved tools or methods, and each one of you who attend these conventions should be able to go home prepared to show how some jobs may be handled in a better and more economical way than before. The class of work turned out in a shop and the speed and manner of execution is not, however, wholly dependent upon fine tools; for the human element is bound to enter into this to a great extent. If you, through hard and diligent work, produce a new and efficient tool or device for doing a certain job, and it is turned over to a poor or careless workman, your time and his is very likely to be wasted unless the proper supervision is given to see that it is handled in the right way. You should co-operate with the other foremen and the men themselves, that your influence may tend to have a good effect throughout the shops.

PRESIDENT'S ADDRESS

To standardize and systematize our work means a gain for our employers and gives a better basis to the purchasing department for commercial contracts. In considering these activities of the association, that the construction of the association must be based upon information given by its members, I wish to call your attention to the fact that co-operation is the only

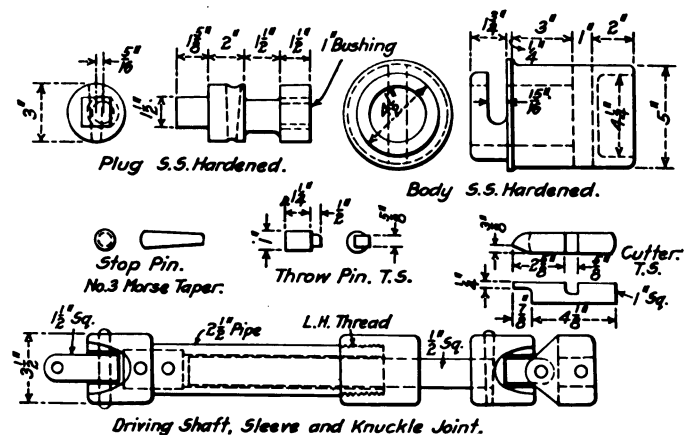

Fig. 2—Superheater Flue Cutter

road to success in our work. This association has grown to be recognized, not only by our employers, but also by the tool industries of the country. The manufacturers are interested in our progress. We are coming here once a year to hear the progress made with certain tools or methods. We are coming here to get something new to take home to our departments. It is a known fact that the men at the head of the tool rooms are the ones who find out what is needed to accomplish better work. It was for these ideals that we came together and formed this association. It is the expression of appreciation of the results obtained which encourage the extension of the work, and the main function of this association is to widen our knowledge.

SPECIAL JIGS FOR LOCOMOTIVE REPAIR SHOPS

C. A. Shaffer (I. C.)—Fig. 1 shows a new type of angle-drill post, which is obviously an improvement over the or-

dinary "old man." Its adjustable feature makes it especially well adapted for such work as drilling mudring corners. It can be built for practically the same cost as the old style drill post.

Fig. 2 shows a superheater flue cutter, with the accompanying telescope driving shaft and knuckle joints, which has been working very satisfactorily on the Illinois Central. It is driven by

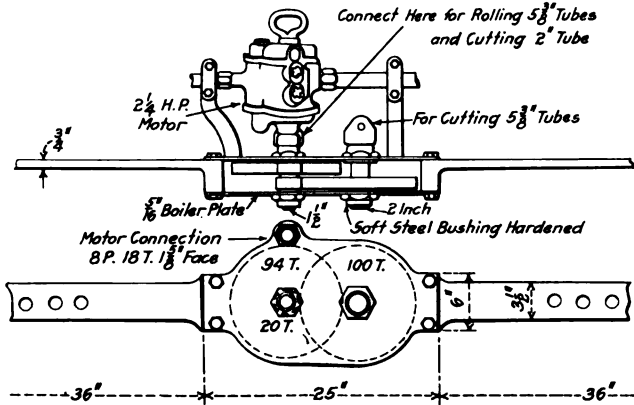

Fig. 3—Apparatus for Driving Tube Cutters in Locomotive Front Ends

the gearing arrangement shown in Fig. 3. This arrangement is also used for rolling tubes. It is secured to the front end of the locomotive, as indicated. The motor drives an 18-tooth pinion which in turn drives a 94-tooth gear. To this gear is rigidly attached a 20-tooth pinion, which drives a 100-tooth gear. Two connections are provided for the driving shaft to the tool, the first gear reduction being used for rolling the large tubes and cutting the small, the second gear reduction being used

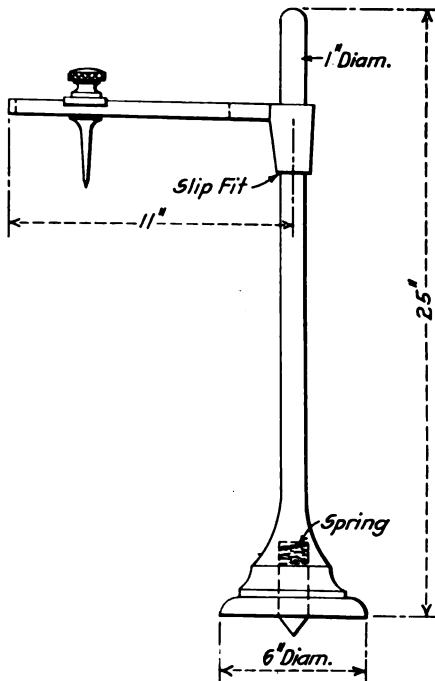

Fig. 4—Tool for Locating Eccentric Cranks

for cutting the large tubes. The casing for the gears or the side bearing plate for the gears also furnishes a neat and safe covering for them.

Fig. 4 shows a tool for locating the eccentric crank on outside valve gear engines. It resembles a surface gage, the face being 6 in. in diameter, resting on the end of the driving axle, a spring center fitting into the center of the axle. The arm, 11 in. or more in length, has a sliding fit on the upright, a gage point being adjustable on the arm. To provide the proper throw to the eccentric the gage point is set at the re-

quired distance from the center of the upright and the tool is placed on the end of the axle. The eccentric crank is then turned on the crank pin until the center of the crank engages with the gage point. It is then rigidly clamped to the crank pin.

Fig. 5 shows a very convenient arrangement for use in boiler shops to transfer the height of the crown sheet to the head of the boiler. It consists of a plug which is inserted in a tube somewhere near the level of the bottom of the fire door. This plug supports, by means of an adjustable screw, one end of a straight edge, the other end on the edge of the fire door. After the boiler has been leveled with the frame the straight edge is leveled with the frame by means of the adjustable screw at the tube sheet end. The height gage, which is adjustable, is then set for the height of the crown sheet inside of the firebox. It is then removed from the straight edge, taken outside of the firebox and used to locate the boiler fittings.

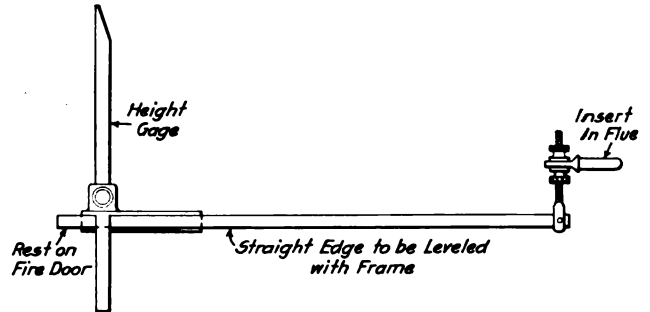

Fig. 5—Device for Locating the Height of Crown Sheets

Charles Helm (C. M. & St. P.)—Fig. 6 shows a jig for babbitting crosshead shoes. It was designed to eliminate the necessity of planing the shoes after the babbitt had been poured. The bottom member of the jig, *A*, is made of steel and is machined all over. It consists of a flat plate with vertical flanges running part of its length. At one end there are lugs which form part of a hinged joint. Parts *B* are guides for the shoe and are bolted to either side of *A*, as indicated in the elevation; *C*, is bolted to the inside end of the vertical flanges on *A*, and serves as a rest against which the shoe is placed. In *A* there are 2 1/2-in.

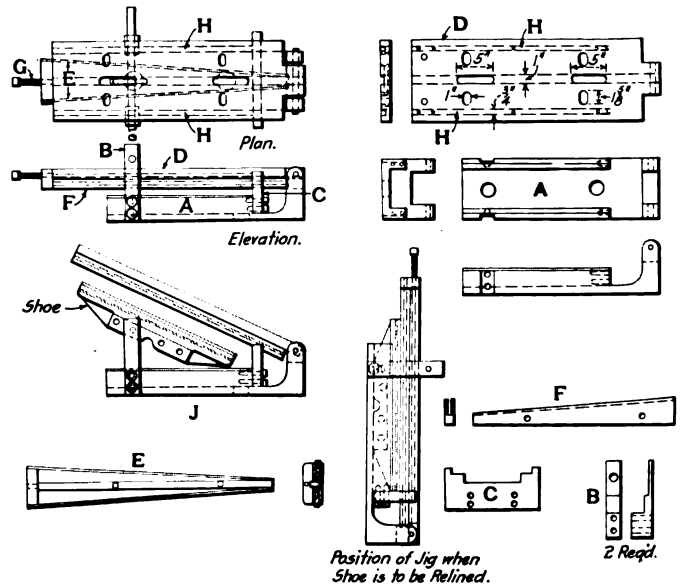

Fig. 6—Jig for Babbitting Crosshead Shoes

holes through which a stick is run for making the oil holes in the babbitt of the shoe. A flat plate, *D*, serves as a cover and is hinged to *A*, as indicated. It has two slots, 5-in. by 1-in., into which shoulder bolts in *E* enter for holding *E* and *D* together; *E* is held central in *D* by a tongue which fits in a groove running

the entire length of *D*. It is a wedge-shaped forging, machined all over. Dovetailed tongues are machined, as indicated on the sides. These fit into corresponding dovetailed grooves in *F*, which is also clamped or bolted to *D* by four shoulder bolts passing through the four 1-in. by $1\frac{5}{8}$ -in. holes in *D*. The purpose of this construction is to permit of regulating the width

usually saves many more. Among the interesting and time-saving devices at the Decatur shops of the Wabash is the valve steam-port miller which is shown in Fig. 7. This is used for milling steam ports in valve seats on slide valve engines, and for milling keyways in axles. The frame was made from an old steam chest, and the balance of the machine from the forgings and castings to be found around any locomotive shop. The cross rail is fed along the base of the machine by lead screws on each side, being operated by one shaft through bevel gears. The milling tool is driven by an air motor applied to the taper spindle.

A special radial attachment has been applied to the large planing machines for planing the fit of the cylinder saddle to the radius of the boiler. A column is mounted on top of the machine and to one side, which supports a pin on which the radius bar rotates. The other end of the radius bar is connected to the top of the tool head, which is allowed to slide freely up and down. The head is clamped at a small angle from the vertical in order that, as the tool head moves across the rail, it may be free to slide up or down, as the case might be, responding to the pull of the radius rod. In setting up the cylinders to operate with this device it is necessary that the center of the cylinder saddle come very nearly below the center of the pin of the radius rod. By increasing or decreasing the length of the radius rod, any desired radius may be obtained, and it will be seen that as the

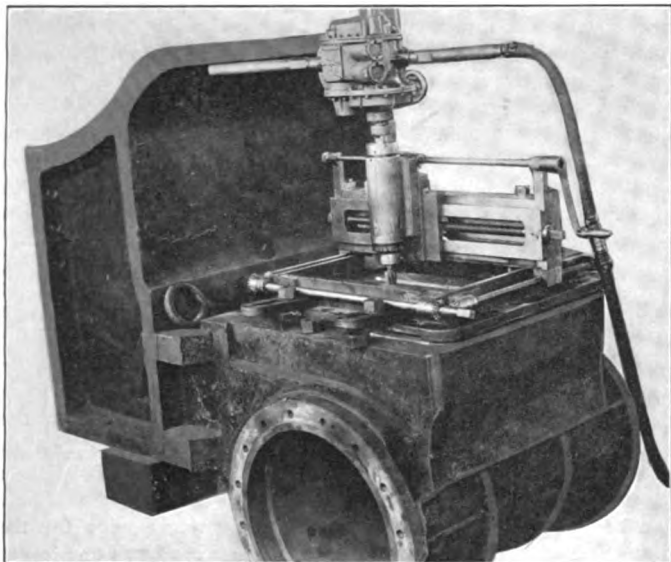

Fig. 7—Valve Seat Port Miller

of the babbitted surface in the shoe to allow for the lateral wear of the guide. On the end of *E* there is a flange, as indicated, provided with a tap hole. Through this hole is screwed the regulating screw *G*, by which the adjustments are made. After the correct width has been obtained, *E* and *F* are securely bolted to the top *D*. On the lower face of *D* there are two $\frac{3}{4}$ -in. by $\frac{3}{4}$ -in. grooves *H*, into which are inserted corresponding pieces, which are held by set screws, for the purpose of

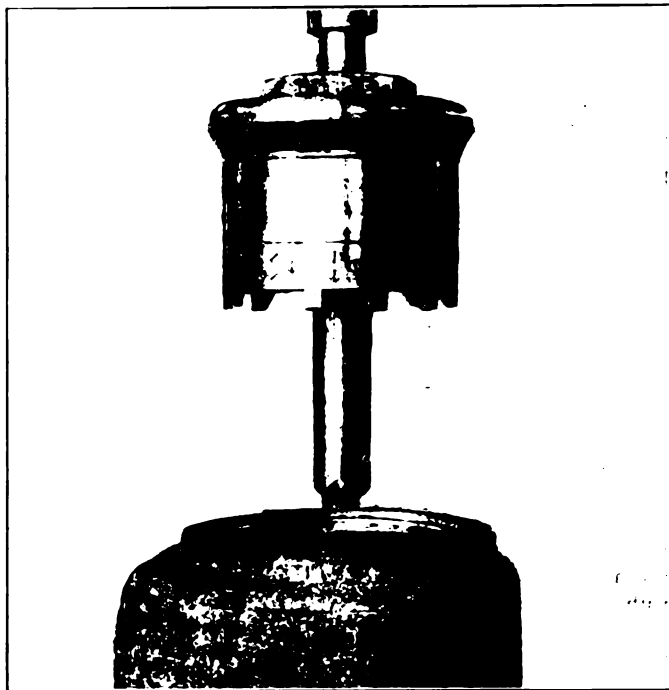

Fig. 9—Reamer for Throttle Valve Seats

tool move away from the radius pin it will be raised in the tool post, thus making very nearly a true circle. This has been found to be a much easier method of preparing the cylinder saddle for the boiler than chipping.

Fig. 8 shows a jig for grinding the joints between the dry pipe and the front tube sheet. The frame is bolted across the front of the smoke box, and an air motor is used to drive the eccentric. The eccentric rod attached to the grinding shaft gives it an oscillatory motion, permitting the joint to be ground as if by hand. The shaft between the frame work and the dry pipe joint is adjustable. A mechanic and helper can grind the worst dry pipe in an hour with this jig and the motor does the work.

Fig. 9 shows a reamer used for boring and facing the seat of throttle valves for large engines. The job was previously handled on a boring mill and was very difficult, taking about $3\frac{1}{2}$

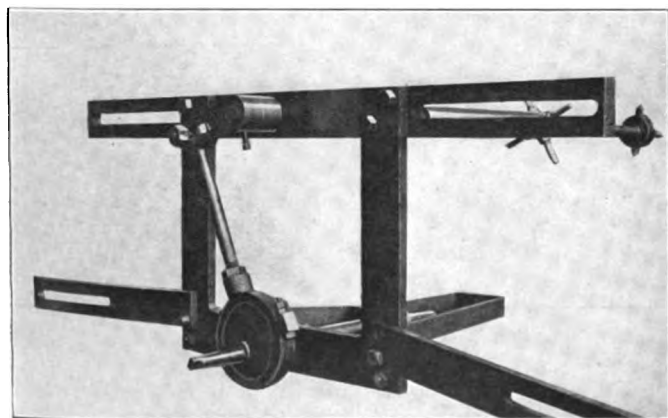

Fig. 8—Jig for Grinding Dry Pipe Joints

covering the side of the shoe to prevent the babbitt from leaking out of the jig.

The crosshead shoe to be babbitted is placed in the jig, as shown at *J*. It rests on the bottom piece *A* and the top piece *D* is dropped into position. A rod is passed through the holes in the uprights *B*, and a wedge driven between the rod and the top *D* to hold the shoe firmly in position. The jig is then turned up on end, as indicated, and the babbitt metal forced in. When the babbitt is cold the shoe is ready for application to the engine, no machining being necessary.

C. T. Brunson (Wabash).—The tool room should be looked on as the economic center of the shop, the place to go to get the cost of production cut, and a place where every dollar spent

hours to do the work. With this reamer the work is done on a radial drill and can be finished in about 20 minutes.

Beading tools made of high speed steel have been found to be expensive, and the life of the tool is very short, due to the brittleness of the steel and the variation in the temper. These are now made of vanadium alloy steel, which costs approximately 15 cents a pound. The cost of production has been reduced by about two-thirds and the average life of the tool is longer.

Fig. 10 shows a drilling device for drilling holes in the side sheets of locomotive boilers. It is virtually a portable drill, being operated by an air motor. The motor is held on a geared head operating on a lead screw supported on a large frame, which is sufficiently heavy to give the proper stability. The

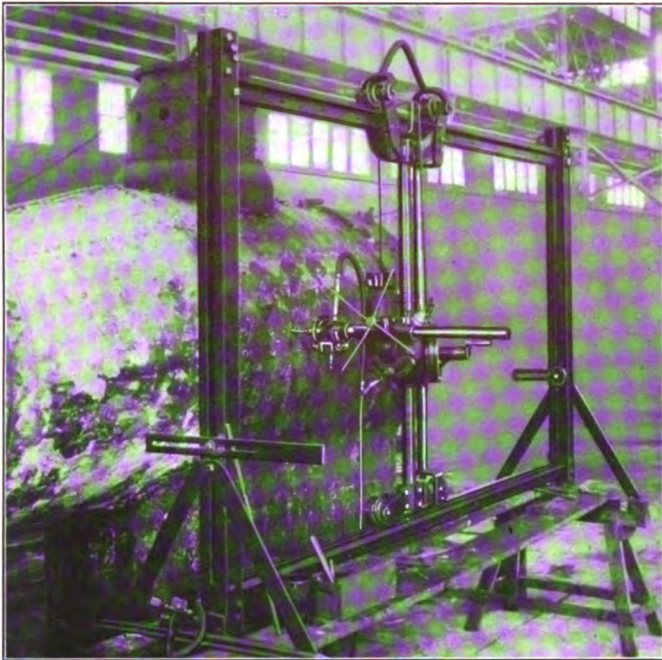

Fig. 10—Arrangement for Holding Air Motors for Drilling Boilers

motor may be raised or lowered as desired, provision also being made to clamp it at any angle to the spindle. Chains are sometimes thrown around the boiler, as indicated in the photograph, for greater stability. This has been found to be of greatest convenience in drilling staybolts, studs, etc., in side sheets. We also use a gang punch for punching jackets, 18 holes at one blow, with equal spacing.

B. Henrikson (C. & N. W.)—The Chicago & North Western has eliminated the key type of crosshead, and is now using the design in which the piston rod is held in the crosshead by a large castle nut. Fig. 11 shows the dies for making both the blank and castle nuts, the dies being made in this case to fit a 6-in. Ajax forging machine. The dies are sectional, and each half die consists of seven distinct pieces. The main body of the die is made of cast iron; the remaining pieces may be either soft steel or tool steel. If they are made of tool steel they should be tempered, and if made of soft steel they should be case-hardened. As will be noted, the outside plate is recessed to carry another plate, the object being to facilitate the replacement of the outside plate in case of accident. The parts are bolted to the main body of the die by 1-in. studs. The bar is upset in the bottom recess of the die and the castellations formed. In the top recess the center is punched out, completing the blank nut. Only one heat is necessary to do this work. From 3½-in to 4¼-in. nuts may be made with these dies.

DISCUSSION

A number of interesting devices were described, a blackboard being provided for making sketches. A method of making

split keys from flattened scrap tubes was mentioned by Mr. Shaffer, of the Illinois Central. After the tubes have been flattened they are punched to shape, leaving the bend at the side of the tube caused by the flattening, to hold the keys together. An ingenious home-made universal joint which was of simple construction was mentioned by one member. It consisted of two U-bolts linked together and fitting in the shafts, being held in the shafts by set screws. Several members spoke of their success with inserted tooth reamers, holding the teeth by caulking. It was believed, however, that they should only be used in reamers of 1¾-in. diameter and over. Inserted tooth taper reamers were made with lugs at each end of the teeth to fit in corresponding pockets in the body of the reamer, to prevent climbing out. A successful inserted tooth taper tap was also mentioned as being of special advantage in reaming out and tapping blowoff cock holes.

SAFETY FIRST

E. J. McKernan (A. T. & S. F.)—There has been a large amount of money spent in making safety improvements in order to eliminate personal injuries to employees, but this cannot be accomplished unless the co-operation of each and every employee is obtained. While the men are showing more interest in the matter there is still need for greater co-operation. When an employee sees anything hazardous or unsafe he should make a special effort to notify the proper party so that such conditions can be remedied, not only for his own protection, but for the protection of his fellow-workmen. In many instances employees bring accidents upon themselves by being careless and placing themselves in danger when they could easily avoid it. The shop should be maintained in a clean and sanitary condition as an unhealthy man is more liable to be careless and thus injure himself or his fellow workmen. When employees find it necessary to pass through railroad yards in going to and from

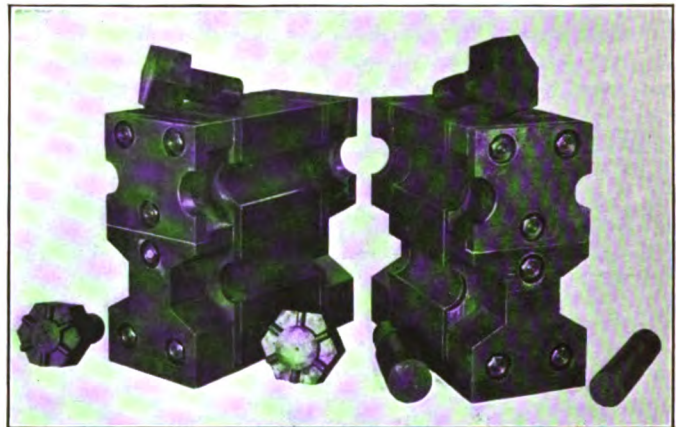

Fig. 11—Dies for Forming Large Castle Nuts

work there should be positive instructions forbidding them from hopping on and off moving locomotives and cars.

In applying or removing belts from various machines throughout the shops, employees other than those assigned to this work should not be allowed to handle them, as serious accidents have occurred to those who are inexperienced. Too much care cannot be exercised in mounting and taking care of grinding wheels. There have been numerous accidents caused by the following: Improper inspection of wheels; wheels mounted on improper sized spindles; wheels mounted with only one flange; flanges having uneven bearings causing wheels to crack; flanges of different diameters; loose emery wheels; improper method of truing up the wheel; forcing wheels on taper arbors; wheels running at improper speed; wheels running out of true, and improper rest used for emery wheels permitting the work to pass down between the wheel and the rest. It has been found to be bad practice to allow any emery wheel to be im-

mersed in water, especially where half of the wheel is immersed and the other half is not. This throws the wheel out of balance. It is also bad practice to grind on the side of an emery wheel. The threads on the spindle of an emery wheel should run in the opposite direction to the way the wheel runs, as the nuts will become loose and the wheel is liable to fly off the arbor. Care should also be taken to see that the driving belts do not become crossed. Men who are called upon to do a large amount of grinding on emery wheels should be provided with goggles.

The following items should be watched carefully to prevent accidents: Projecting set screws; walking under loaded cranes; using weather-worn or oil-rotted rope for lifting heavy loads; using defective chains or hooks; permitting tools to be left where they may fall on the heads of workmen; use of defective hammers and sledges; splitting nuts with a chisel; wearing gloves when operating machines, and wearing loose overalls; passing in front of locomotive boilers when tubes are being removed; loose brick or cinders on overhead walls; shooting out of frame bolts with dynamite during working hours; defective shop floors, and the use of chipping hammers for driving in reamers. We have been able to materially reduce the number of accidents by the adoption of the safety attachment on sectional expanders, eliminating the possibilities of the pin flying out and thus injuring the operator.

Gust Gstoettner (C. M. & St. P.)—To overcome dangerous conditions it is necessary that the co-operation of the men be obtained. Cleanliness and tidiness should be one of the first rules. The emery wheel protection hood, including an adjustable glass for protecting the employee, is a very good safety device, for, as a rule, the men will not always wear the goggles when doing this work. In making guards for machinery they should be constructed at as low a cost as practicable. Common sense and a little good judgment by the operator himself are required to make "safety first" a success.

R. B. Fletcher (Belt Railway of Chicago)—A large number of machine manufacturers have altered the construction of their machines in order to reduce to a minimum the possibilities of injury to operators. One very important factor in the elimination of injury to shop employees has been the adoption of motor driven machinery. The special controlling features for machines have also added a great deal to the safety of shops. The tool foreman is in a position to greatly assist in the "Safety First" campaign by being sure that unsafe tools are not passed out to the workmen. Every effort should be made by the foreman, as well as the safety committee, in encouraging the men to report all unsafe conditions.

From a study of accidents it has been found possible to eliminate only 50 per cent. of the injuries by guarding the machinery; the other half are the direct result of carelessness by the men and must be overcome by the education of each individual workman. A great deal can be accomplished in this direction by closely watching the actions of each new employee to see if possible whether or not he is inclined to be careless. Careless employees should be carefully instructed and warned against danger.

George Nutt (C. G. W.)—It is the duty of every employee to report dangerous conditions immediately. Machinery should be kept in proper condition and grinding wheels inspected regularly, to see that the speed has not been altered or improper flanges substituted or the hoods removed. The average grinding wheel is not broken under fair usage. Other safeguards which will help to eliminate accidents are good lighting, whitewashed walls and ceilings, which serve a double purpose, as they are sanitary and help to provide plenty of light. The gangways should be kept clear and the floors, especially around machinery, should be kept in good condition. It is a good plan to post bulletins as accidents happen, stating how they happened and making comment on them, showing how they could have been prevented. By doing this the employees will become interested,

especially when a fellow workman is hurt, and will undoubtedly look out to see that he does not get injured in the same manner.

DISCUSSION

W. G. Reyer, general foreman of the Nashville, Chattanooga & St. Louis, was called on to make a few remarks at the Tuesday morning session. He spoke of the importance of the tool foremen and of the opportunities they have for increasing the efficiency of all railway shops. He dwelt on the necessity for all those in charge of men to study their human characteristics with a view of handling them with the least friction and with the best results for the company. Speaking on the subject of "Safety First," he spoke of the necessity of operators using goggles where their work required it, and of the necessity of obtaining a glass for the goggles that would not break easily. Clear aisles in any shop are essential and protruding nails in the flooring should be carefully guarded against. He called attention to a sign that he had seen in some shop stating, "Safety First is all right, but a careful man is essential."

Other members, speaking of goggles, stated that it had been found difficult to have the men wear them consistently. One member said that an employee using an emery wheel without them should be disciplined. Various methods are adopted to keep the goggles in an antiseptic condition. Some use a mixture of alcohol and water; others use a steam cylinder, while some use a mixture of one-half wood alcohol and one-half water for sterilizing, and then rinse the glasses in plain water. Several members objected to the lack of goggles for use with eye glasses, stating that in those on the market to-day the shield does not extend far enough back to fully protect the eyes.

Many members spoke of the necessity of obtaining the co-operation of the employees in order to get the best results from the "Safety First" movement. The men should be made to feel the necessity of their individual help. On some roads the members of the safety committees serve only three months, in order that the spirit may be infused in as many employees as possible.

It is necessary to carefully inspect all chisels and flatter heads to keep them in proper condition. Some roads do this every morning and find that it is far better to grind off the heads than to have them dressed by the blacksmiths. The following are some of the special safety features reported:

Use paint brushes for wiping the chips away on milling machines.

Use a fine wire netting under balconies to prevent material falling into the machines on the main floor.

Steel blocks recessed to receive the frame are used on some of the heavy locomotive cranes.

Stand behind milling cutters, not in front of them.

Paint the sides of emery wheels to prevent the men grinding on the sides.

Platforms fitting over the top of the boiler, and which can readily be handled by cranes, are serviceable for removing dome caps.

Recessed collars shrunk on the chuck of wood boring machines, and large enough to cover the set screws, are being used by several roads.

Use portable screens.

Use only headless set screws.

Bolt plates into spoked gear wheels.

Apply springs to the flap of fast running shapers to keep the tool down, and thus eliminate the necessity of the operator using his hands for this purpose.

Leave the paper disc on emery wheels.

MAINTENANCE OF PNEUMATIC TOOLS

J. J. Sheehan (N. & W.)—When the delicate construction of the working parts of the pneumatic motor and hammer and the narrow margin between efficiency and inefficiency are considered, it will be found that there are no tools in the shop that receive harsher treatment.

Facilities must be provided for the removal of water and dirt from the air before it enters the pneumatic machine. The removal of water can be accomplished by having a suitable sized settling tank provided with a drain valve, close to the point of operation. The most effective strainer for keeping the dirt out of the tool is that made of a double thickness of muslin placed in the air line back of the tool. The pneumatic tools must be kept properly lubricated. On the Norfolk & Western

a satisfactory and cheap lubricant has been found in mineral lard oil, one containing marked emulsifying properties. Drills and hammers should be standardized as far as possible, both in styles and sizes, as it makes the maintenance easier and a smaller number of repair parts are required.

A simple arrangement for holding air drills while they are being repaired consists of a plain screw jack which has outlived its usefulness as a jack. The handle of the drill may be placed in the hole in the head of the jack and clamped with a set screw inserted at the top of the jack. This will readily permit of holding the drill firmly in any one position desired. It is important to know, after a drill has been overhauled, what per cent. of its rated energy it will exert. Fig. 12 shows a method of making a rough test for this purpose. A hydraulic

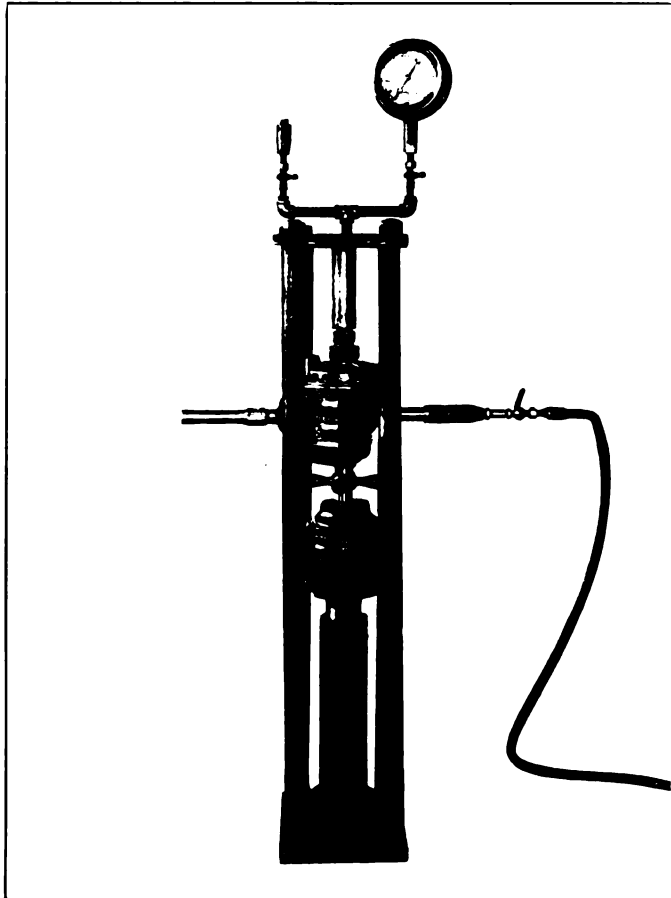

Fig. 12—Apparatus for Testing Air Motors

jack is placed in a frame in which is placed the pneumatic drill. A hardened friction ball is placed in the drill socket and runs in the corresponding friction bearing in the top plate of the frame. The pressure cylinder of the jack is connected to the gage at the top of the frame. After the motor is started the feed screw is screwed down on to the jack, increasing the friction of the ball in the socket, thus giving a combination of torque and thrust, exactly what occurs in feeding a twist drill. The area of the contact between the ball and the roughing surface may be regulated to give the friction desired. If the record of a drill of a particular class when new is 800 lbs. on the gage, this will be considered 100 per cent. efficiency. All other tests of the same class of drill are compared with the original record, and no drill is allowed to pass below 75 per cent. A drill failing to meet the required pressure is thoroughly examined for wear. In many instances the piston will be found to have been worn. It is expanded, by heating, .002-in., then a turned plug of the required diameter is inserted and the piston allowed to cool on the plug. The plug receives the

heat from the piston, and after it is sufficiently cool, it can be easily removed, leaving the piston expanded the proper amount. Cylinders have also been closed on certain classes of drills by pressing through a block bored to the required size. This has produced satisfactory results.

In the pneumatic hammers it is found that if the valve casing is worn .002-in., the hammer will be unfit for service. In order to locate the difficulty in this respect a new valve is kept at hand to try the hammers. The valves are purchased .002-in. over size, thus allowing a certain amount of reaming to put them in working condition. It has also been possible to take worn valve casings and roll them in a sheet iron roller, closing them a sufficient amount to put them in serviceable condition. The joints between the head and the cylinder, and between the head and the valve casing, should receive close attention. When they become uneven and leak the facing tools shown in Figs. 13 and 14 are used to correct the trouble. The feed nut for the facing tool serves as a guide.

John B. McFarland (N. Y. C. & St. L.)—The air motors for the use of the boilermakers are kept in the boiler shop, and those for the machinists are kept in the tool room. Once a week they are filled with lubricant and inspected. The hammers are cleaned and oiled once a day when in use. We have overcome trouble with broken tangs on the square chuck sockets by cutting off the left-hand thread on the chuck, replacing it with a right-hand thread, and screwing on a nut. The other end of the nut is made to fit the threaded end of the motor, the nut tightening on a shoulder at the same time that the taper shanks tighten in the motor sockets. With the chuck fitted in this way it is possible to drive a square socket tool to the capacity of the motor.

In the small hammers a bushing with a taper hole is used, and a taper shank is made on all tools. The bushings are reamed out with a No. 2 Morse taper reamer, which leaves a hole

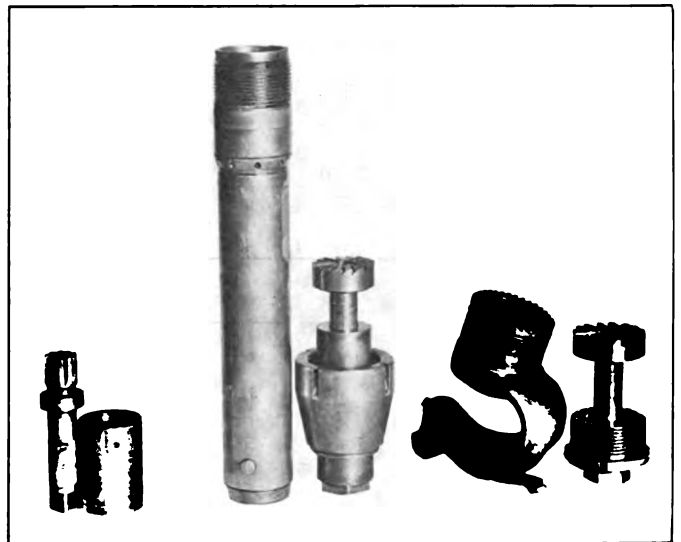

Fig. 13—Tools for Facing Air Hammer Connections

about $\frac{3}{4}$ in. on the large end and allows the use of $\frac{3}{4}$ in. octagon chisel steel for tools. This has stopped the breakage of shanks on such tools. A bushing will last from six months to a year before it becomes too large to impair the stroke of the hammer. This has been tried on large hammers with good results.

E. G. Nabell (Southern Ry.)—In selecting pneumatic tools, the economical operation and the cost of maintenance should receive the first consideration, not the first cost. As a means of producing better maintenance and higher efficiency from pneumatic tools the operators should be educated to use the tool that is best adapted for the work at hand, and to take

proper care of the tools, particularly with reference to dropping them or striking them with a hammer, or allowing grit or any foreign substance to get into the throttle of the machine when it is not connected to a hose. All pneumatic tools should be inspected and tested at regular intervals, cleaned and thoroughly lubricated with a good grade of lubricant. By keeping a close record of the repairs to the tools it will be possible to determine just what and how many repair parts should be carried in stock. When the tools are sent to the tool room for repairs they should be taken apart and thoroughly cleaned. An air hammer, when not in service, should be kept submerged in a good quality of light, clean oil to insure the thorough lubrication of all parts and prevent rusting. Where possible, it is desirable to confine the repair work on pneumatic tools to one mechanic who has become thoroughly familiar with the tools.

August Meitz (M., K. & T.)—It is a good policy to adopt a standard for pneumatic tools on any one railroad system. This would reduce the cost of repairs and maintenance about 50 per cent, as well as reduce the expense for repair parts to be carried in stock. The operators should be educated in the matter of the proper use of pneumatic tools; that is, they should use high-speed motors when they are required, and slow-speed

hammers. Where this carbon deposit has been found some cut it out with gasolene, while others have succeeded in burning it out, the throttle being removed, and then washing in gasolene. Some roads insist that the men lubricate the hammers every hour; the hammers are assigned to the men and they are responsible for them. On the Santa Fe the air hose is inspected regularly and the air hammers are turned into the tool room for inspection every night. The men are required to remove the hose, and oil with a special oil that is provided, after the hammer has been used for a considerable time.

GRINDING AND DISTRIBUTION OF TOOLS

G. W. Smith (C. & O.)—On the Chesapeake & Ohio the tire turning tools, after having first been ground to the standard gage, are maintained by the operators of the lathe, an emery wheel formed to the standard shape being used for this purpose. For lathe, planer and brass work a chart is made showing the shape and class of work the different tools are required to do. For touching up lathe, planer and various other tools, general purpose grinding wheels are installed in different parts of the shops for the convenience of the workmen. The twist drills, however, are ground to a standard of 59 deg. in the tool room. The milling cutters and large reamers are ground in the tool room. Gear cutters, reamer cutters and tap cutters are ground on a dished wheel. With this style of wheel it is possible to grind to the bottom of the flutes with ease and a good cutting edge is obtained. It has been found that the dry grinding, if care is exercised and too heavy a cut is not taken, is better than wet grinding. Where water is used a large amount is necessary to prevent cracking the tool by over-heating the outer surface.

Each lathe is provided with a cupboard in which a reasonable number of standard shaped tools are kept. Many of the operators take care of their own tools. This same method is used for planer, shaper and slotter tools. Special tools for brass and turret lathes are kept in racks close to the particular machine, and when broken or dull are brought to the tool room for repairs. Twist drills and rosebit reamers are kept in the tool room in racks, and given out on checks.

J. C. Beville (E., P. & S. W.)—The wheel lathe tools are ground in the tool room. The round nose tool is ground with a 6 deg. clearance, 8 deg. back slope and 14 deg. side slope. The finishing tools are made to finish the entire width of the tire with one tool in one operation. They are ground with a 6 deg. clearance and an 8 deg. back slope. By grinding these tools in the tool room but little additional work was necessary, and it is believed that at least 25 per cent better work is obtained on the machine. All the other tools are maintained by the operator of the machine on which they are used. However, there is no doubt that better results could be obtained if these tools were ground by an expert, for it is a question whether the machine operators really know how their tools should be ground to produce the best efficiency. High speed steel is undoubtedly a fine material to use for such tools when they are hardened and ground properly, but in many cases carbon steel tools, if properly ground, could be used with as much success as the high speed tools improperly ground. This is a big field for the tool foreman to establish system in the handling of machine cutting tools. On the Chicago Great Western, at Oelwein, Iowa, the tool dresser is directly under the charge of the tool foreman.

J. C. Hasty (A., T. & S. F.)—Grinding machines should be kept as far away from other machinery as possible to avoid the dust getting onto the wearing parts of those machines. Where wet wheels are used care should be taken not to press the tool too hard against the stone, in order to avoid burning the steel, causing cracks to appear. The open grain dry wheel gives the best results for redressing high speed steel. All the lathes, planers, boring mills, shapers, etc., are equipped with a sufficient number of tools for the class of work performed

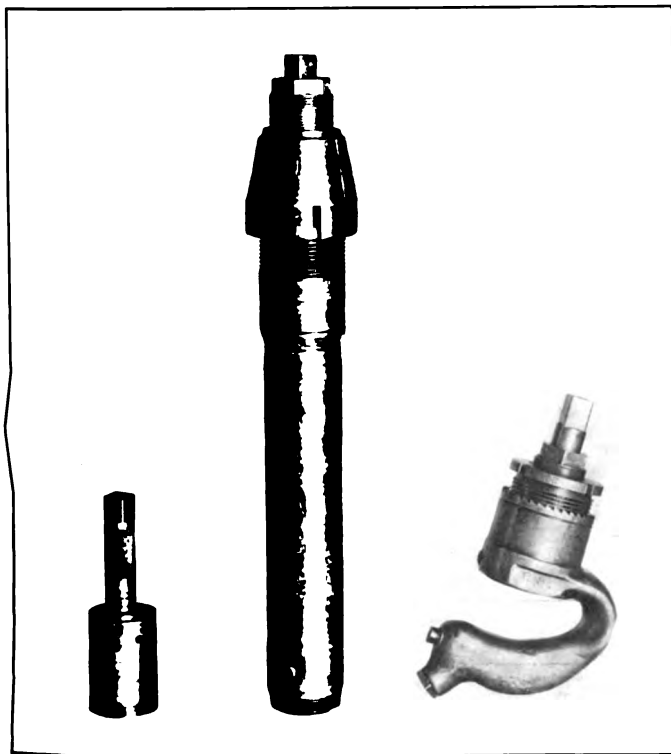

Fig. 14—Tools for Facing Air Hammer Connections

motors when they are required. Much damage is done to the motor, as well as to the tool, when this is disregarded. Good engine oil should be used to keep the motors lubricated, and it will also be found to pay to use some light grease, such as Keystone or vaseline, in the crank case. The motors should be kept in good repair and inspected regularly. It has been found to be good practice to place the hammer, after it has been in service, in a solution of gasolene and signal oil, mixed half and half, as small particles of rubber from the hose lining frequently lodge in the chamber between the handle and the throttle valve. The gasolene will cut the rubber, and by blowing the hammer out with compressed air the refuse and foreign substances will be removed.

DISCUSSION

It was believed that excessive oil in air compressors gets into the delivery line and gums up the throttle valves in the air

on the machine, each operator having a locker in which these tools are kept and locked when not in use. A man is appointed to take care of all machine tools, chisels, and chisel bars. He goes to the machine, collects all the machine tools that require redressing and takes them to the smithshop. He then grinds them and returns them to the workmen, no workmen being allowed to take their tools to and from the smithshop. When tools become short from redressing they are forged to smaller sizes, down to $\frac{1}{2}$ in. by 1 in., for use in the tool holders.

DISCUSSION

While it was generally believed that much better results could be obtained in the machine shop if the tools were maintained by the tool room force, the practice on most of the roads seems to be to allow the machine operators to grind all but the very special tools. On the Wabash, none of the machine operators or machinists are allowed to grind the tools. The drill presses are equipped with tool boxes containing a set of tools which are charged to the operator. When they become worn they are exchanged at the tool room. Other roads provide similar systems, while some keep a complete set of tools at each machine, which are replaced when they become worn. On the Santa Fe, all the drilling machines are provided with a chart showing the speed and feed for each size drill to be used on the different kinds of material. This insures that the benefit of the high speed drill will be obtained without spoiling the drill. It was also pointed out that where high speed drills were used the work should be securely clamped to the table, in order to prevent the breaking of the drills under heavy cuts. Mr. Pike, of the Rock Island, reported success in welding high speed tips on soft steel tool bodies.

STANDARD REAMERS

The committee reporting on the standardization of reamers for locomotive repair shops recommended that all taper reamers in sizes under one inch be the commercial standard. In sizes over one inch, three overall lengths were recommended: 18 in., 20 in., and 28 in. The square shank on reamers $\frac{7}{8}$ in. up to and including 1 in., was recommended to be $\frac{7}{8}$ in.; on sizes from 1 in. to and including $1\frac{3}{8}$ in., 1 in. square; on sizes over $1\frac{3}{8}$ in., $1\frac{1}{8}$ in. square. The length of the square was recommended to be $1\frac{1}{4}$ in., the length of the collar $\frac{1}{4}$ in., and the clearance between the end of the flute and the collar, $\frac{3}{4}$ in. The taper was recommended to be $\frac{1}{16}$ in. in 12 in. The left-hand spiral was recommended, due to the fact that it will eliminate the feeding of the reamer too fast, and greatly reduce the number of breakages. On reamers under $1\frac{5}{8}$ in., two flutes less than the standard were recommended, and on all sizes over $1\frac{5}{8}$ in., four flutes less than the standard were recommended, the reason being that a much stronger flute and a longer life of the reamer will be obtained.

OTHER BUSINESS

The secretary reported a cash balance of \$90.16. The following officers were elected for the ensuing year: President, J. J. Sheehan, Norfolk & Western; first vice-president, C. A. Shaffer, Illinois Central; second vice-president, J. C. Bevelle, El Paso & Southwestern; third vice-president, C. T. Brunson, Wabash; secretary-treasurer, Owen D. Kinsey, Illinois Central. It was voted to hold the next annual convention in Chicago.

SETTING AHEAD THE CLOCKS IN DETROIT.—In order to gain more daylight time, the industries of Detroit, Mich., have been placed on eastern standard time, all clocks having been pushed ahead one hour May 15. Cleveland adopted the eastern standard time about one year ago. It seems unfortunate that the cities of the Middle West cannot hold to central standard time. The confusion resulting from a difference of one hour between local timepieces and railroad time causes many travelers to miss train connections.—*Machinery.*

RELIEF VALVE FOR SUPERHEATER LOCOMOTIVES

By W. B. MIDDLETON

General Roundhouse Foreman, Atlantic Coast Line, Rocky Mount, N. C.

The lubrication of the cylinders of superheater locomotives when drifting is a problem which has presented considerable difficulty. Where relief valves are used the inrush of air when the throttle is closed causes carbonization of the oil, at the temperatures found in the steam passages; this results in the destruction of its lubricating qualities and the accumulation of carbon on the cylinder walls and in the steam ports. In many cases the use of the relief valve has been discontinued in order to prevent this action, with considerable benefit in the elimination of carbonization. But without the relief valve there is danger of the locomotive moving with no one in charge, owing

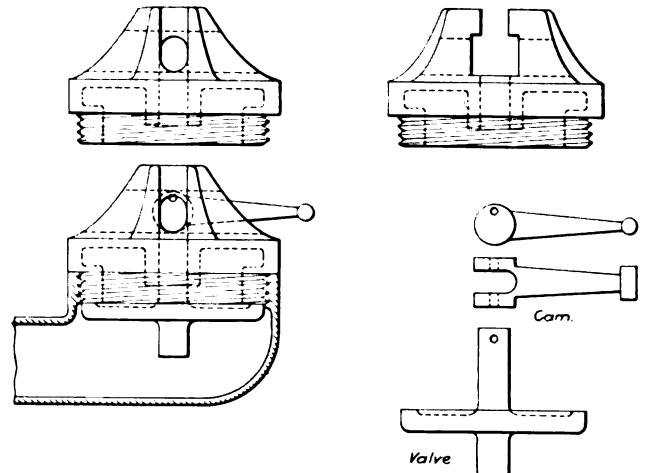

Cam-Operated Relief Valve for Superheater Locomotive

to the accumulation of pressure from a leaky throttle or to possible carelessness in the closing of the throttle.

In the drawing is shown a type of relief valve cap designed to retain the advantages of the relief valve at terminals, on storage tracks or at lay-over points, but to permit its positive closing while the engine is in service. Caps of this type may be applied to the valve bodies now in service. In the top of the cap is a milled or slotted tee slot into which the cam, shown in the drawing, is inserted. With the cam and valve in place the two are connected by a pin inserted through openings provided in the sides of the tee slot. The throw of the pin hole in the cam is equal to one-half the lift of the valve, and by throwing the cam from the position shown to the other side of the cap the valve is completely opened.

CLEANING CASTINGS.—In a leading article in the *Electrical Review*, dealing with lubrication troubles, it is stated that the difficulty with new turbine and engine bearings is frequently attributable to the fact that manufacturers do not clean the castings properly. Castings are never properly cleaned of sand, even externally, by the still common methods of brushing and coke rubbing, and in steam ports and passages it is hopeless to expect cleanliness from such antiquated methods. The most effective way for removing sand seems to be to pickle the castings. First, they are roughly cleaned and fettled and then hosed with weak hydrochloric acid. When sand is present this spreads the acid by capillary attraction, and the result of a few hours of acid action is to remove all sand and to leave the surfaces clean and free from hard silicious scale. Afterward the castings are washed with warm water dosed with soda to neutralize any remaining acid.

THE GENERAL FOREMEN'S CONVENTION

Reports on Valves and Valve Gears, Shop and Engine House Efficiency and Oxy-acetylene Welding

The eleventh annual convention of the International Railway General Foremen's Association was held at the Hotel Sherman, Chicago, July 13 to 16, W. W. Scott, general foreman of the Delaware, Lackawanna & Western, presiding. The opening prayer was made by the Rt. Rev. Samuel Fallows, D.D., LL.D., presiding bishop of the Reformed Episcopal Church, and the association was welcomed to the city by William Hale Thompson, mayor of Chicago. L. A. North, superintendent of shops of the Illinois Central, at Burnside, responded to the mayor.

PRESIDENT SCOTT'S ADDRESS

The increased size of locomotives has in some respects put to a test the capacity of the general shop and roundhouse foremen, who, in order to meet the increased demands on their intelligence, are becoming affiliated with various mechanical organizations for the purpose of gaining knowledge to meet the new conditions in the most intelligent manner possible. As to the future of this organization, I am very much in favor of the consolidation plan as briefly outlined by President Gaines in his opening address at the last convention of the American Railway Master Mechanics' Association. I believe it means that the minor associations will obtain more helpful recognition from the larger associations, which in turn will lead to a better understanding and co-operation along the lines of economical standardization of locomotive parts and appliances. I am in favor of this organization delegating the chairman of the executive committee to advise and act with other executive chairmen of all mechanical organizations for the purpose of exchanging views on this subject, bringing to the next convention a report of his findings. However, I would not favor any plan being adopted that would take away from the minor organizations their individuality.

VALVES AND VALVE GEARING

The most important problem that confronts the motive power department at the present time is to bring about economy in locomotive operation. The valve motion is next in importance to the boiler in determining the efficiency of the locomotive as a whole; hence the vital importance of a proper design, construction, and maintenance of this feature. Poor steam distribution results in loss of power in the engine, excessive fuel consumption, and an increased cost of repairs.

The value of indicator diagrams in the study of valve events cannot be overestimated. The indicator card shows plainly whether or not the engine has the proper valve setting. The idea that as long as an engine sounds square, the valve motion is all right is a fallacy. A number of new engines were received on a certain road that were extravagant on fuel, the main pins ran hot, and the engines were logy in movement, and would not handle their rated tonnage. The indicator was applied, and the diagrams revealed a condition showing excessive cylinder clearance. It was found that the pistons were only 5 in. thick instead of 6 in., as specified.

There is some doubt as to whether the piston valve is really more economical in steam consumption than the slide valve, and a number of tests have been made, some showing better for one, some showing more economy for the other. It is evident that this question of economy depends greatly upon the design and maintenance of the valve, as a well designed slide valve may surpass the poorly designed piston valve, and vice versa.

One of the principal advantages of the piston valve over the slide valve is the fact that the former is fully balanced, and it is easier to manipulate the reverse lever in the cab.

Slide Valves—A slide valve when used on a very long cylinder gives undue cylinder clearance due to the increased length of ports. The chief advantage of the slide valve lies in the fact that it can relieve itself of excess compression by lifting.

The secret in getting good service from the slide valve is the careful maintenance of the balancing feature. Pressure plates are often lined too far away from the valve, with the result that the latter may vibrate up and down in the yoke. The distance between the pressure plate and the valve should not exceed $3/32$ in. When the balance strip springs have too much set, the end strips have a tendency to wear grooves in the pressure plate. Probably the greatest number of engine failures on account of slide valves are due to broken valve yokes and stems. Most of these are traceable to excessive friction due to cut valve seats, faulty lubrication, or defects in the balancing feature.

Piston Valves—The advantages of the piston valve are: Increased port area for both admission and exhaust; ports in cylinder made very straight and direct; a simpler, lighter and cheaper cylinder casting; its adaptability to any design of valve gear; with inside admission valves the steam passages are better protected from the cold and radiation, and the steam chest heads and packings relieved from high pressure; accessibility of parts; better balance which makes it easier to handle, and decreases the wear and tear on the motion work, and the relative frictional resistance of the piston valve is much less than the slide valve. The greatest disadvantage under which the piston valve labors is its inability to relieve excess pressure in the cylinder port by lifting, after the manner of the slide valve.

Tests made on the Pennsylvania Railroad showed that the piston valve could be largely standardized and that a 12-in. diameter valve was large enough for cylinders up to 27 in., in diameter, when used with superheated steam. There is undoubted advantage in a small valve from a maintenance standpoint; a small valve means a light valve, and a light valve means much reduced stress on the valve motion, especially at high speed.

The piston valve packing rings in general use are the rectangular, the L, the T, and the Z-shaped rings. The L-shaped valve ring is the most widely used of any at the present time. It has the advantage of giving a very much better port opening with less wire drawing of the steam than that obtained with the rectangular ring. On the other hand it has a greater unbalanced surface than the rectangular ring. The T-shaped ring does not possess any special advantage over the L-ring. It has a more symmetrical shape, and perhaps has a more uniform bearing against the chamber bushing. The Z-shaped ring is a modification of the L ring. It is provided, on the edge that fits against the bull ring, with a lip on the outer side projecting about $1/16$ in. into a corresponding recess in the bull ring to prevent any portion of the ring dropping into the port in case it should break up. It is generally conceded that the piston valve is much easier to lubricate than the slide valve. It is mostly at high speeds and in the running cut-off that the matter of lubrication is serious. When superheated engines with piston valves are permitted to drift long distances, the troubles from poor lubrication are overcome by the use of drifting and circulating valves or drifting throttles. It is the consensus of opinion at the present time that the method in which the oil is discharged in the passageway, or in the outside steam pipe is the most satisfactory method of lubrication. On the Illinois Central three circular grooves are cut around each bull ring of the piston valve. It is said this method greatly facilitates lubrication.

The secret of success in the maintenance of piston valves is

the careful fitting of the bull rings and packing rings and the frequent reborings of valve cages so the rings will have a perfect bearing on the cage. Also the valve rod crosshead must hold the valve stem in perfect alinement with the line of bore of the chamber.

Cast iron for valve rings should be tough and close grained. It is claimed that Hunt-Spiller gun iron possesses these qualities. Many roads report having obtained excellent results from the use of this material. The latest practice in piston valve bushings is a cast iron bushing with vanadium content. The common method in applying valve rings is to use rings from $\frac{3}{64}$ to $\frac{1}{8}$ -in. larger than the bore of the bushing, and cut out enough so that they will have between $\frac{1}{32}$ and $\frac{1}{16}$ -in. opening when the valve is in place. The best fitting packing rings are turned to the old piston ring rule—the rings are turned from $\frac{3}{32}$ to $\frac{3}{16}$ -in. larger than the bore, according to the size of the valve, then from $\frac{3}{16}$ to $\frac{1}{2}$ -in. cut out, the ring clamped in a jig, and turned to the exact size of the cage. The standard practice card of the American Locomotive Company for a 14-in. valve requires rings $14 \frac{5}{32}$ -in., then $7/16$ -in. cut from these, and next closed with a $1/32$ -in. temporary liner, and turned to the bore of the bushing while clamped in this position. A very effective method of turning rings to the bore of the cage has been developed on the Illinois Central. The packing tubs are slotted with a slot from $3/16$ -in to $5/16$ -in. wide, depending on the diameter of the ring. The pot is then clamped together and turned to the size of the bushing. A second chucking is required to face the opposite side. Some railroad men contend that rings turned with from $3/32$ -in. to $1/8$ -in. snap come to a bearing very soon, and that the other method is an unnecessary refinement.

It seems to be the practice in most shops to machine valve rings from a pot, using an engine lathe or a boring mill. The vertical turret lathe possesses special advantages for this work, and where used has given splendid results. In a number of shops expanding chucks are used for holding valve rings while the wearing face is turned, and a rotary saw is used for the work of cutting out.

The vertical turret lathe is probably best adapted for machining bushings of the sectional type, but in some cases it may be possible to get equally good results from the boring mill. At the Schenectady Works of the American Locomotive Company, a vertical milling machine which has a special rotary feed attachment is used to machine the cored port openings in valve bushings. The bushing is held between two flanged discs, one of which is fastened to the spindle of a worm gear. The feed handle is attached to the screw which drives the worm gear. In the West Milwaukee shops of the Chicago, Milwaukee & St. Paul, a similar attachment is used in connection with a shaper.

Two general methods are used for putting in valve cages; one is to heat the chamber and push or pull the bushing in, and the other is to pull it in with a wrench by use of a threaded rod with plates and a nut. Without question a portable hydraulic ram is the most effective means yet devised.

It is the practice on a large number of roads to rebores bushings after they are in place. When piston valve bushings are rebored the valves are not interchangeable, and a standard sized packing ring and bull ring cannot be maintained. For this reason it is the practice on several roads to renew bushings instead of reboring them. When piston valves are properly taken care of the bushings should run at least 200,000 miles without reboring, provided the valves were properly fitted in the first place.

By far the greatest number of blows in piston valves are due to cut and worn packing rings, and bushings that are out of round or shouldered, but occasionally a blow will result from other causes. Blows not commonly met with are due to the following causes: Bushings loose in the valve chamber allowing steam to blow through; cracked bushings; bull rings

cracked or loose between the spool and follower; sand holes in the spool or valve body, and followers loose on the valve stem. It is the practice on some roads to make a periodical examination of piston valves, in order that failures and inefficiency from this source may be avoided as far as possible.

When sectional valve bushings are used it is sometimes a difficult matter to get the valve entered in the second bushing on account of the valve dropping down between the bushings. In order to facilitate matters in this regard, the New York Central provides piston valve cylinders with a guide strip cast in the bottom of the valve chamber. In some engine houses the work of pulling valves for inspection has been greatly facilitated by the use of a simple contrivance consisting of a slide made of pipe or bar iron which is supported by the valve chamber studs on one end and by feet on the pilot beam.

The formation of carbon in the valve chamber often makes it a very difficult matter to pull out the valve. At Burnside on the Illinois Central an oxygen burner is used to burn out the carbonization in valve chambers and steam and exhaust ports.

A great deal of the trouble experienced with lame engines on some roads is due to defects in the valves themselves, and not from distorted valve gears. In order that square valve events may be obtained the valves and bridges must be of the correct dimensions to give the desired lap and exhaust clearance, and there must not be the slightest variation on the two sides of the engine.

Valve Gears.—At the present time four general designs of valve gears are used in this country. They are: The Stephenson link motion; the Walschaert valve gear; the Baker valve gear, and the Southern valve gear. The principal advantages of outside valve gears are: Accessibility for lubrication, inspection and repairs; opportunity for heavy cross bracing between the frames; motion can be made more direct, and with fewer wearing parts, and ability to hold their adjustment for a greater length of time.

The disadvantages of the outside valve gears are: Liability of damage from side swipes; rod work, changing of tires, etc., made more difficult due to the location of outside valve gears, and slight distortion of the valve events due to up and down movement of the main wheel, and with it the eccentric crank, and back end of the eccentric rod.

Aside from the matter of good steam distribution, there are a number of items that must be considered in the selection of a valve gear for different classes of service. They are: First cost; cost of maintenance and repairs; efficiency and reliability of service; ability to hold adjustment, and ease of handling in the cab.

Three of the most important features to be considered, in the design and construction of an outside valve gear are: Necessity for providing as rigid a support as possible; provisions for reducing wear to a minimum, and providing sufficient lubrication at every point.

The advantages to be derived from the use of high class materials for valve gear parts have been recognized, and at the present time the tendency is to use steel for these parts. The recent Pennsylvania engines have all motion work parts of heat-treated steel. Soft steel is used extensively for transmitting and other valve gear rods, and the jaws are usually case-hardened to give good wearing qualities. Cast steel is only adapted for certain parts, and where used should be annealed. The American Locomotive Company follows the practice of using drop forged motion work parts wherever it is possible to do so. Drop forged motion work parts have the advantage of requiring very little finish, and are strong and durable.

The outside valve gears produce a more uniform steam distribution with a lower percentage of preadmission than the Stephenson link motion. They hold their adjustment, and consequently give a better steam distribution for a greater length of time.

Some trouble has been experienced on several roads, the

eccentric crank cracking, due to the spreading action when the crank is driven on the main pin. The Pennsylvania has a design of channeled eccentric crank with the slot and binding bolt on the inside. This design overcomes the liability of cracking when spread as in the ordinary type. On this same road it is the practice to key main crank pins to the driving wheels.

Without question the method of setting valves to get best results, is to take one engine of each class, and make changes as shown by accurate indicator tests, setting the other engines of that class accordingly. However, the sound of the exhaust is usually depended upon to determine whether or not the valves are square and distributing the steam as they should. A slight variation in the cut-off, even though it is not discernible from the sound of the exhaust, greatly affects the load on the piston.

Steel tubing can be obtained in all sizes, and is especially adapted for motion work bushings, requiring very little finish. This practice is followed on a number of roads. The best practice is to grind bushings, inside and out, to a standard gage, and this method is followed by most builders.

The Stephenson gear possesses the peculiarity of being exceedingly sensitive to a close adjustment of all its parts in order that a correct action and proper distribution of the steam may be obtained. It is the most flexible of any in use and can be most readily adapted to irregularities in the running and operation of the engine. At the same time it will get out of adjustment very easily, and requires the utmost care in its design in order that it may work properly. With the link motion in actual service there are three sources of error which cause a variation in the same events for the two ends of the cylinder, and which must be compensated for in some manner. They are: The location of the eccentric rod pins back of the link arc; the angular vibration of the eccentric rods, and the angular vibration of the connecting rod. To a certain extent the latter two compensate for the first, but not entirely, and to complete the compensation the hanger stud is set back of the link arc. The object of this offset is to hang the link so that it has a rising and falling motion on the stud to counteract the difference in motion between the forward and back strokes.

In certain classes of service the variable lead given by the Stephenson link motion permits the locomotive to accelerate more rapidly and to better adjust itself to different operating conditions than is possible with the valve gears giving a constant lead. Variable lead and flexibility are the chief characteristics of the gear.

The tendency at the present time in setting valves operated with the Stephenson gear is to reduce the full gear lead, or rather to adjust the valve gear to the running cut-off and permitting the full gears to take such lead as the length of the eccentric rods will give, or to specify the lead in full gear, and sacrifice the back motion in order to get the required lead at quarter stroke.

There are a number of Walschaert valve gear designs in service which do not give the best results due to the fact that proper care has not been taken to properly proportion and locate the parts to compensate, as far as possible, for the irregularities inherent in all valve gears. The most important items to be considered in the design of the Walschaert gear are: The location and proportions of the link; the location of the reverse shaft; the location and throw of the eccentric crank, and the necessity for a true deduction of the crosshead travel to that of the valve stem.

The Walschaert gear may be designed to give a variable lead. This is suitable only for passenger and fast freight locomotives; and not for slow freight and switching locomotives. It is necessary to make the eccentric crank of a different length than for constant lead. No change in the method of proportioning the combination lever is necessary except that its length must be such as to give the lead required when the radius bar is in the center of the link.

In order to eliminate as far as possible the necessity for set-

ting the Walschaert valve gear, a system has been perfected, by the Baltimore & Ohio, whereby gages are used.

The link is by far the most troublesome part of the Walschaert gear. It is the largest item in the cost of maintenance of this gear. Many different methods are used to take up the wear, but the work can be done most efficiently by the radius grinder.

Most of the engine failures from the Walschaert gear are caused by the carelessness of workmen. Many failures are due to neglect; nuts are not properly tightened on the motion work pins, and cotter keys are not put in place.

Baker Gear.—The Baker gear differs from all other locomotive valve gears in that it entirely eliminates the link, obtaining the reverse and cut-off movement by means of a reverse yoke and radius bar. It resembles the Walschaert gear in many respects, and offers all of the advantages claimed for the latter, but with important additional advantages, which are: The oscillating link, is eliminated; the total weight of the reciprocating parts of the Baker gear is considerably less than that of the Walschaert gear, and the gear is standardized so that one design is applicable to all engines regardless of the size or class.

The Baker gear gives a constant lead with a variable preadmission. In full gear there is practically no preadmission and the indicator cards show a low compression line. It is claimed that the Baker gear gives the longest release for a given cut-off and lap condition of any valve gear in use. On account of its entire lack of sliding connections, the fact that each bearing is essentially of the pin and bushing type, and because of its extremely light weight and rigid construction, this gear requires very little maintenance while in service.

Southern Valve Gear.—The Southern locomotive valve gear is the latest development in outside valve gears and embodies certain principles not heretofore used in outside valve gear construction. The advantages claimed for this gear are: It has few parts, thus tending to reduce the reciprocating weights; it has only eight possible points of wear or a total of sixteen points of wear per locomotive; transforming from a rotary motion to a reciprocating motion is accomplished by direct movements, and on straight lines, doing away with strains and distortions; the stationary link, which does away with what is generally called the slip in the link block; the crosshead connection has been eliminated altogether.

Young Valve Gear.—An entirely new design of radial outside valve gear has recently been developed by O. W. Young. It was designed with the object of taking care of the large cylinder volumes now being used, and hence a gear of greater capacity than those now in use. The Young gear has capacity for greater travel without excessive angularities. This permits more lap, lead, and exhaust clearance, and in consequence wider openings without change in the time of the events. Preadmission, release and closure will take place at the same period of the stroke, but the added area will facilitate the rapid flow of larger volumes.

The report is signed by:—Walter Smith, (C. & N. W.), chairman; C. A. Barnes (C. & W. I.); G. W. Keller (N. & W.); T. M. Dewar (C. & O.); B. F. Harris (So. Pac.); J. Miller (Ill. Cent.); N. J. Shasberger (N. Y. C. West); C. D. Rafferty (K. & N.), and F. Anderson (C. St. P. M. & O.).

DISCUSSION

The greater part of the first two sessions was devoted to the discussion of this report, which covered 65 pages in the advance sheets. One member strongly advocated the Stephenson valve gear for switch engines because of the variable lead which assists in starting. While the piston valve is accepted as the best all-around valve and is especially desirable on superheater locomotives, some roads have found that the slide valve could be made to work satisfactorily on these locomotives. The Delaware, Lackawanna & Western is using these valves with a special system of lubrication. There is quite a difference of opinion re-

garding the use of superheater valve oil on superheater locomotives, some claiming that as good results could be obtained with Perfection oil, which gives less trouble in the gumming up of the ports.

Some members reported favorable results with common gray iron piston valve bearings, while others believed that special metals give enough better service to warrant the additional expense. W. F. Lauer, of the Illinois Central, reported that on a test run with a superheater passenger locomotive fitted with Hunt-Spiller bushings and rings, 266,000 miles had been made using one pint of valve oil for every 65 miles. It was clearly shown that from the standpoint of economical operation it is very necessary to keep the valves in first-class condition. There was, however, quite a difference of opinion concerning the maintenance of piston valves. Some roads advocate boring the valve bushings after they have been applied, in order to insure that they are perfectly round. It is generally the practice to rebore the valve chamber when it is a scant 1/32-in. out of round. However, some roads never rebore the piston valve bushings, believing it better to remove the bushing and apply a new one, thus keeping the diameter standard, and requiring a less number of packing rings to be carried in stock. It was believed by one member that if the valves are kept properly lubricated they will not have to be rebored in three or four years. Several roads inspect the valves for blows every 30 days, some making these inspections every 60 days, while others make no inspection at all. Those roads operating under the assigned engine system believe that regular inspections of the locomotives operated in this way are unnecessary.

The Pennsylvania makes a practice of marking the date the packing rings are applied to the valves and cylinders, in order that their service may be properly followed. Some members believed that much better results would be obtained from packing rings if, when they were made, they were clamped together after they were split, and turned to the proper size. It is claimed this will provide a more even bearing on the piston valve bushings.

Where the balanced slide valve is used it was believed to be the better practice to use springs only under the two long strips suspending the side strips from them. This will reduce the wear on the top bearing plates. One road has found that the bronze valve seats in superheater slide valve engines do not give desired results. Where graphite is used care should be taken that too much is not fed to the cylinder at one time.

The use of the piston valve accessories, such as vacuum valves, has been quite generally done away with. Good service records were reported for both the Baker and the Walschaert valve gears. Special stress was placed on the necessity for proper and careful design of valve gears. One of the most important claims made for the Baker gear is the standardization of parts for all locomotives.

RODS, TIRES AND WHEELS

Rods.—One member of the committee was strongly in favor of the rectangular rod as against the I-beam rod, saying that the rectangular rod is much less subject to fracture and that it is about 20 per cent. cheaper to make. The material in the rod should be mild steel, without welds. The forked end rod was recommended, as there is less work in maintaining this style of rod, as but one bolt is required against three for the strapped end, and there is also about one-half as much surface to be trued up when the rods are undergoing general repairs. For the crank pin bearings in the side rods on heavy engines the split brass and straps was recommended for the reason that it is less expensive to keep them in proper condition. Where the strap is used a steel liner should be used between the key and the brass in order to insure a broad bearing surface on the back of the brass.

One road is experimenting with cast iron crank pin bushings with babbitt blocks dovetailed in them on some large freight

engines. One set has been running five and one-half months and so far shows but little wear. While the cost of making these bushings is more than for making the brass bushings the difference in the cost of metal materially offsets this difference. One road has tried both brass and steel bushings for knuckle joints, and found the steel to be more efficient. It was pretty generally conceded that all rods should be annealed at least every one or two years. When the rods are removed they should be given a thorough cleaning and a very careful inspection to detect any flaws. Among the many causes of broken rods and poor service are the rods being out of tram, the engine being out of tram, rod collars binding on the rod brasses, the pins worn out of round, undetected flaws in the straps or rods, the engine out of quarter and the engine not properly counter-balanced.

When applying the bolts to strap end rods care must be taken to have them fit properly in the strap at the top and bottom. To accomplish this the middle of the bolt may be turned about 1/32 in. under to insure a good bearing fit in the strap. On strap end rods one road is changing from the key to the wedge type for safety and durability. It is found they give better service and they eliminate a lot of extra work. One road is using the electric welding process to build up the worn parts in the metal end of the rods and for welding small cracks in the jaws and rods to prevent them from getting larger. The knuckle joint pin should be carefully inspected at all times to prevent the possibility of the knuckle joint pin nut becoming loose, allowing the pin to work out and catch on the driving wheel. Care should also be taken to keep the side rod collars from becoming loose for the same reason. It was recommended that cotter keys be placed in all main rod keys in conjunction with the two set screws, to provide additional safety.

Tires.—Locomotive tires should not be too soft nor too hard. Those that give a wear of 1/32 in. a month are considered satisfactory. It is recommended by one member that a lip be placed on all tires to facilitate the setting, and also to prevent the tires from creeping in when they become loose. The rim of the driving wheel centers should be 5 in. wide to give a proper bearing surface on the tire. One member recommends that the wear of the tire in the center be not allowed to exceed 1/4 in., and that flat spots should be limited to 1/16 in. in passenger service and 1/8 in. in freight. For a minimum thickness of tire the Soo line uses the following: For 44-in. to 50-in. inside diameter tires the minimum thickness should be 1 3/4 in., for 56-in. tires, 2 in., for 62 to 68-in. tires, 2 1/8 in., for 72-in. and over, 2 1/4 in. When the tires get thin the driver brakes should be watched to see that they do not drag.

In the application of tires various methods were suggested. Some use commercial gas, others gasoline, natural gas, fuel oil and wood fires. One road reported that with a wood fire eight new tires were applied in 42 minutes. A shrinkage of 1/80 in. to a foot in diameter was considered to be good practice. Retaining rings were recommended for passenger engines, and the use of shims was believed to be bad practice on new tires. They should be bored to fit the wheel center. One road removes old and worn out tires by cutting them with the oxy-acetylene flame and wedging them apart so that they may be easily taken from the wheel centers.

Cut flanges are caused by the guiding wheels being out of square, the wheels out of tram, the lateral motion not properly distributed, the engine leaning to one side and the engine not being level on the track. Where other means for reducing flange wear are not obtainable, some roads have found that steam led from the steam end of the air pump through 1/4-in. pipe and discharging through a 1/32-in. hole in the end of this pipe serves to lubricate the flange very nicely.

Driving Axles.—Steel was believed by the committee to be the best material of which to make driving axles. One road has run successfully axles 1/2 in. below their original size, while

another road will remove the axles when they are $\frac{1}{4}$ in. below size. When axles are in for general shopping they may be found perfectly round, but eccentric. It was therefore recommended that they be turned at each general shopping. A careful inspection should be made for flaws near the hubs, and the axles that have given trouble from hot boxes should be given careful inspection. It was generally believed better to lay out the key way for the eccentrics on Stephenson gear engines before the engine is wheeled, this saving considerable labor.

Crank Pins.—Where shops are equipped with quartering machines it is considered good practice to test all pins for quarter and stroke at every shopping. Main pins having the main rod brass bearings outside of the side rods, are changed every ten years on the Soo line, as it is found that they break at about that time. On other roads they are changed oftener. One road removes all crank pins that show in excess of $\frac{1}{16}$ in. wear on the bearing surface, and makes new pins from old driving axles. The washer on the end of the crank pin should be very substantial and strongly attached to the pin. It should not be attempted to file a pin round as it is very liable to become eccentric. One road adopts the practice of stamping the date and the shop at which the crank pins are applied for the information of the man who next handles the engine in general repairs.

The report is signed by A. A. Masters, chairman; W. G. Reyer (N. C. & St. L.); M. J. Hayes (C. H. & D.); A. D. Clark (C. G. W.); A. B. Corbett (M. K. & T.); W. T. Gale (C. & N. W.); W. F. Lauer (I. C.), and A. F. Taylor (M., St. P. & S. S. M.).

DISCUSSION

Several members reported that they were discarding channel rods and applying the rectangular or slab rods on account of the channel rods breaking. On heavy engines a number of the members recommended strap end rods on the middle connection. Where bushings are used, care should be taken that they are not pressed in at too great a pressure, as it is believed that the stress thus imposed destroys the life of the brass. The Lehigh & New England has increased the bearing of the bushing in the rod with very good success, and anchors the bushing at the top and bottom with a plug. Special metal, such as gun metal, has been used instead of brass for rod bushings with very good success, if it is properly lubricated. Some roads have even used gray iron.

Several members spoke strongly in favor of the automatic flange oiler, but it was pointed out that the enginemen should be carefully instructed to handle it properly. Some roads require the engine inspector to start the oilers before the engines leave the terminal.

Several methods were reported for heating the tires, the cheapest being that where wood was used as a fuel the wood being scrap material. The Soo line applies tires by this method at a cost of 16 cents a piece. Where shimming the tires was found necessary it was believed to be the best practice to use continuous shims. Several members reported that they were using cast iron for hub liners, while one uses no hub liners until the wheels become sufficiently worn, then bronze was used. This road uses oil cellars in the driving box.

SHOP EFFICIENCY

The greatest factor in effecting and maintaining shop efficiency is competent supervision.

Competent supervision, insuring competent workmen, make it possible for an old shop, with less modern tools and facilities, to not only equal, but exceed the output of the modern shop with the latest improved facilities, which, however, is poorly supervised. The foreman and the gang foreman who is in direct touch with the individual workman is the man who is largely responsible for efficiency and his qualifications necessarily must be many. A combination of executive and mechani-

cal ability is to be desired, and if he lacks in either, it is better that his executive ability be the greater.

He must be able to gain and hold the respect of his men by quiet insistence on the observance of the rules in effect. He must be quick to recognize men's individual capabilities and assign them work for which they are best qualified. He must be able to systematize and outline his work so that there are no lost movements or delays. He should be diplomatic in his dealings with department foremen, insuring harmony, though insistent upon work required from them being handled promptly. He should enthrone his men to such an extent that they take a pride in equaling or excelling an exceptionally good performance made a matter of record by another department or shop. He should be active and energetic as an example to his men, dealing fairly with them, never, under any circumstances, allowing personal feelings or prejudice to influence his treatment of them.

Close supervision is conceded to be profitable, and no foreman should have under him more men than he can keep in touch with intelligently. He should be able not only to know what each man is doing, but how he is doing it.

Weekly foremen's meetings, held in some suitable office, and presided over by the shop superintendent or general foreman, are essential to efficiency. All department foremen and a representative from the store department should attend these meetings. Engines undergoing repairs should be considered, each in their turn (it being assumed that a schedule time is set for all classes of repairs). Every department being represented insures that the dates given for completion of repairs will be nearly accurate, and a thorough understanding of the conditions is reached by all concerned. Shop problems and difficulties should be thoroughly threshed out and differences between various departments adjusted.

Shop Schedules.—No shop can be efficient unless there is a fixed time set for the completion of repairs to the engines. There is no real need of an elaborate schedule which covers the time each separate part of an engine must be finished, but there is an absolute need of a schedule which allows a certain number of hours for each class of repairs handled, consistent with facilities the shop affords.

The Chicago & North Western has had a schedule in force for a great many years past, and its worth was proved very shortly after its inauguration. Forms termed "In and Out Sheet," spaced to show engines on pits in each gang under the heads Gang 1, 2, 3, 4, 5, etc., are made out each week and show all engines in the shop, with their schedule dates. At the foremen's meeting, if it is found that the repairs cannot be finished on the schedule date, a later date is set and is shown on the form under the heading "Engines delayed." Several large blackboards are placed in conspicuous parts of the shop, and engine numbers and dates out of the shop are shown on these boards.

In addition to these a number of slips are printed each week after the dates have been confirmed or changed at the Foremen's meeting. The slips are distributed to all men on machines who do a special line of work, and to the various special men who work on the erecting floor.

The men post these slips on their cupboards or in any place where it can be readily seen by their foreman, and as they complete their work for an engine, they draw a line through its number on the slip, and the foreman in passing can see at a glance whether or not a man is within the time allowance set for the completion of his particular work.

If, by reason of financial depression, it is necessary to operate a 20-pit shop, for instance, with only enough men to properly handle ten engines, put but ten engines in the shop and get them out as quickly as possible, as even with the closest kind of supervision and checking of labor and material charges the cost of repairs on twenty engines handled with a ten-engine force will

be above the usual cost of repairs, when engines are repaired in their usual time. There are a number of logical reasons for this, but we will mention only two: The first and principal reason in a shop which has been working full force under a satisfactory schedule, is, of course, the changes which must unquestionably be made in the schedule time, thus causing disorganization of the systems, and making for confusion and its attendant delay.

The second reason is the noticeable relaxation of efforts of the working forces who, under a short schedule, were keyed to a much higher pitch, and the need of haste to get work completed on time kept men energetic and active, but the lengthening of the schedule has seemingly indicated to them that the need of haste has been obviated and that they now have lots of time, and it is a difficult matter to keep them from taking it. Schedule time as short as consistent with conditions, makes for efficiency.

Facilities.—Modern facilities make for efficiency and where an improved tool or appliance will show a consistent increased output sufficient to pay a good rate of interest on the investment, it should be bought and installed. An inferior tool, forced on a supervisor, which will not equal the output of the one he specified, is discouraging and does not tend to increase shop efficiency.

Whatever the equipment, it can and should be worked to its limit. Machines should be worked to their safe capacity as to speed and feed. The capacity is easily determined by crowding on the feed.

Machines should be so located that there are no retrograde movements necessary on work which several machines must care for, the shortest movements possible should be made from the time the work is delivered to the initial machine until its completion at the last machine.

High speed drills are as essential as high speed tools. Jigs and gages for drilling and laying out cost money to make, but this cost is negligible when results are considered and you must have them to be efficient. Devices which expedite the movement of any work should be made and put in use.

A sufficient supply of small tools in good condition must be available, such as taps, dies, reamers, cutters, wrenches, files, etc. The cost of small taps and files is so small that it is possible for a machinist working with either a tap or file in unserviceable condition to consume enough extra time in three hours' work to pay for a brand new tap or file.

Manufacturing Department.—Undoubtedly all roads have recognized the large measure of efficiency obtained through the manufacturing department, in which all parts of locomotives are made or finished, and delivered to the store department for stock, and in turn distributed to all smaller points on the system. This department necessarily has the most modern machines and facilities. The men employed are specialists. Jigs, templates, formers, arbors and clamps should be, and usually are, found in great abundance in this department. The store department can reduce the efficiency of the manufacturing department by not ordering a large enough quantity of certain materials.

Tool Room.—In a large shop where mechanics get their own tools on checks from the tool room, the delays of a minute multiplied by the number of times they occur in a day and by the number of men affected, run into hours, which in turn mean dollars. Therefore, energetic, quick moving and thinking men, who know the condition of all tools in their charge, and who do not leave a defective tool where it may get in service, are necessary. The average railroad tool room absolutely cannot expect to compete with the manufacturer as regards the making of small tools and dies. We should never make or repair anything which we can buy equally as good for less cost, except in an emergency case.

Apprentices.—An apprentice makes for efficiency in proportion to the amount of interest he shows and the amount of in-

terest that is taken in him. Select boys with as good an education as possible and who have a real desire to master the trade they wish to follow. Give him every opportunity to thoroughly learn his trade. Apprentice schools increase the efficiency in some shops—why not schools in all shops? Employ all apprentices on probation, and if it is seen at the expiration of six months, after an earnest and conscientious effort to make him qualify, that he is not adapted to the trade, dismiss him, as he may make a splendid success in some other line of business, and you will have done him an injustice if you allow him to serve his time and then be obliged to put up with his incompetency or dismiss him, with four years of his time wasted.

Shop Demonstrator.—A thoroughly competent demonstrator in a shop of any size is an absolute necessity. It is through his efforts largely that maximum capacity of machine output is obtained. He is invaluable because of his intimate knowledge of machines, enabling him to break in a new machine or a new operator on any machine which is at all complex. His work is not confined to machines, but to any proposition which needs close checking to insure results. It takes an intelligent and absolutely fair-minded man to qualify for this position, and qualifying, he certainly does much to insure efficiency.

Store Department.—The store department can increase the efficiency by keeping a stock consistent with the mechanical department's needs and the prompt shipment of necessary material to the unfortunately located foreman of shops at an outside point where only stock common to ordinary requirements is carried. When it is considered that, as stated by G. S. Goodwin, in a paper read before the Western Railway Club of Chicago, last February, the average value of a locomotive's services through the United States was \$44 a day, it is problematical whether the cause of efficiency is best served by the store department keeping material so low that at any time it makes for an engine delay. The question should be given the most careful analysis.

Storekeepers and shop supervisors must keep in close touch. Advance notice of engines to be shopped and the probable material which will be needed given to the storekeeper enables him to make special requisitions for this material, and it is usually available when the engine is finally shopped.

Shop Appearance.—Shops should be roomy and well ventilated; windows so designed and lighting systems so planned that there are no dark spaces and glare of sun or lights so modified that the eyes of the employes are not subjected to any undue strain; lockers and toilet rooms sufficient for the convenience of all employes should be installed and maintained in an absolutely sanitary condition. The shops should be kept clean and tidy. Material and engine parts should be piled and never be allowed to be thrown promiscuously around the floor. The grounds about the shops should be kept as neat as the interior of the shops.

Timekeeping and Checking.—A little less than two years ago an improved system of checking the work performed by individual men was installed in the Frisco shops. Certain mechanics were selected as checkers. The duty of these men is to be constantly about the shop during working hours, recording in some detail the operations performed by the various men under their care, and setting down the time at which such jobs are begun and finished. It has been found that one checker will handle from 60 to 75 workmen. The actual working time saved by not requiring the individual men to make out their distribution cards has more than paid the wages of the checkers employed. In addition to this accurate records of the work performed and of the time consumed are obtained.

In connection with this system of checking, all the clerical work of timekeeping and labor distribution has been concentrated in the office of superintendent of motive power. This has reduced the total cost of keeping time and distribution by approximately one half.

Routing.—Each engine, as it arrives at the shop for repairs, is thoroughly inspected and the work to be performed recorded. The routing man, who is, in fact, assistant to the general foreman, makes out the necessary forms covering the engine, and with the advice of the general foreman determines the number of days which shall be allowed for the completion of repairs.

The routing man then fills in the detail dates for the completion of each of the individual operations. Cards are then prepared for each department and gang foreman.

By this scheme the general foreman is relieved in a large measure from following up the smaller details of work on the engine; the routing man makes numerous daily trips through the shop checking up his sheets to ascertain what work is falling behind the schedule. A delay report placed on the general foreman's desk each morning calls his attention to the departments or gangs which are falling behind. The individual foremen are also relieved of tracing their work through other departments, and the gang and department foremen are able to devote their entire time to the supervision of work under their charge.

Standardization of Tools.—The Frisco employs a supervisor of tools, who is a specialist in tool design and operation. By a careful study of conditions and by an accurate check of the equipment in use this man has been able to materially reduce the cost of tool maintenance, and at the same time to increase its quality. All the cutting tools for the system are manufactured in a central shop, thus insuring perfection of design and quality and the lowest cost of manufacturing. No tool steel whatever is furnished to outside points, which prevents the misuse of expensive high speed steel, by allowing it to be worked up by inexperienced mechanics.

When sufficient pit room is available and the time locomotives are in the shop is of no great importance, a scheduling system could be worked out that would give fair results. But there are not many railroads that have more shop capacity than is required when business is good. Consequently, locomotives should be repaired and gotten out of the shop with the least possible delay.

A good system for obtaining maximum efficiency from a locomotive repair shop provides for a hurry-up meeting each morning. At this meeting the erecting shop foreman will inform the general foreman of the exact status of repairs. He will also give him a list of material that may be needed to complete the repairs. The other foremen, being on hand, can answer for any material that belongs to their department. The entire subject of output and material can be handled in from fifteen minutes to half an hour, and many subjects that may interest two or three or more departments can be disposed of at once. The general foreman knows at all times the state of repairs of each locomotive.

The report is signed by: Geo. H. Logan (C. & N. W.), chairman; J. M. Kerwin (C., R. I. & P.); J. C. Newmarch (N. Y. C.); C. M. Newman (A. C. L.); J. Miller (I. C.); E. E. Greist (Penn. Lines); F. A. Byers (St. L. & S. F.); Wm. Smith (P. & L. E.), and W. T. Abington (C., R. I. & P.).

DISCUSSION

The discussion on this subject brought out the point that the general foreman should deal with the subordinate foreman direct, rather than go beyond them to the men. Most members believed that a schedule of the locomotive parts through the shop was desirable. Some roads go into more detail than others in this matter. On the St. Louis & San Francisco, at Springfield, Mo., a man is assigned to the routing of the material through the shop, and acts as an assistant to the general foreman. Another man devotes his whole time to checking up material, making shortage reports every day, and keeping after the store department for the material needed. The routing man also makes a daily report and red marks the work that is behind. On the Santa Fe there is a material man who works

in conjunction with the shop and store department, and whose duty it is to report shortages and handle scrap and second-hand material.

On the Delaware, Lackawanna & Western there is a special committee appointed to inspect and pass on new devices or inventions presented by the employes, and if these devices are accepted for use the employes are paid in a lump sum. Other roads obtain the patent rights for the men, holding the restriction to use the devices on their own roads without the payment of royalty.

ROUNDHOUSE EFFICIENCY

The roundhouse is the connecting link between the mechanical and transportation department of a railroad. A well equipped roundhouse will do much towards strengthening this link, and it is time that more attention be paid to its construction and equipment, so that it may be brought up to the highest state of efficiency. Too much of the details of the construction of roundhouses is in the hands of the maintenance of way department, and too little in the hands of the man who is on the ground, who has to furnish the power for moving trains, and who knows more than anyone else of what is required for the highest state of efficiency. To the roundhouse foreman belongs the responsibility for engine delays, engine failures, engine mileage, cost of dispatching, etc., and therefore his ideas and recommendations should receive the first consideration. Good light, heat and ventilation are important for facilitating roundhouse repairs, for in order to get good results from the employes conditions should be equal to those of the repair shop. Lockers and adequate toilet facilities should also be provided in order to have conditions the best.

Equipment.—Drop pits for driving wheels, engine and tender wheels should be in all roundhouses where running repairs to any extent are required. An engine may be kept out of the repair shop indefinitely by dropping the driving wheels for repairs to driving boxes, turning tires, etc. Overhead cranes or trolleys should be arranged for removing dome caps, front end doors, bumper beams, etc. Washing out systems effect a great saving as well as protecting the boiler against leaking tubes, and all roundhouses should have hot water, and plenty of it, for washing and filling boilers. Storage tanks, or sumps, should be made large enough to take care of all the water that is blown from the boilers and then used for washing out, reclaiming all of the water by filtration.

There are instances of roundhouses equipped entirely with old tools discarded by the repair shop. This is a short sighted policy. The tools for the roundhouse should be the very best, especially where it is isolated from the repair shop, and it would seem that the repair shop should take the old tools rather than the roundhouse, because the repair shop is in a better position to make repairs to them than the roundhouse.

Roundhouse piping is a subject for consideration. It would seem that the only proper and safe way to install the piping is in conduits of sufficient size to hold all the pipes and easy of access should repairs be necessary. No sewer pipe leading from the roundhouse should be less than 10-in. in diameter and preferably 12-in. Engine house pits, especially drop pits, not properly drained, give off a disagreeable and unhealthy odor.

Roundhouse tracks are also a subject for careful consideration. There should be two inbound tracks, with an emergency run around track, and two outbound tracks. The inbound tracks should be of sufficient length to admit of a water crane a reasonable distance from the entrance so that engines coming in from the road leaking and having low water in the tender can be given water; otherwise with engines ahead, they would die before getting into the house, causing delay. There should be about 350 ft. between the water crane and the coal chute, so that after taking water the engines may move ahead to wait their turn for coaling. There should be at least 600 ft. between

the coal chute and turn table to allow for engines standing after taking coal.

It is difficult to keep steady labor on the cinder pit at the average roundhouse, and for that reason mechanical loaders are being constructed. Damage to cars by fire from hot cinders is a matter to consider, and for that reason pits are being constructed so that the cinders can be dumped from the engine into water. The Chicago & Western Indiana loads cinders with clam shells, the cinder pits containing water to the depth of seven feet. The cinders are loaded into cars at a cost of about 12 cents per car. These cinders are sold to the track elevation department for \$3 per car.

Water cranes should be located, one at the entrance of the inbound tracks, one on the inbound tracks between the cinder pit and turn table, and one on the outbound tracks.

The office and storehouse should be combined in one building conveniently close to a track for loading and unloading purposes and should be made fireproof.

Cleaning engines, on a number of roads, is being discontinued on account of the expense. This would not appear to be a good policy for the reason that the defects are liable to be covered up and may not be detected by the engine inspectors. There are several mechanical devices for cleaning engines, which bring the cost down so much lower than the hand cleaning, that it does not seem that a railroad can afford to entirely dispense with cleaning.

A very material increase of engine mileage can be obtained by the roundhouse foreman keeping up the lost motion in the valve gear, keeping driving box wedges in good shape, watch-

tion to do all that is fair, it is not the intention of the inspectors to cause any hardships. Without a competent man as roundhouse foreman, the best of roundhouse equipment counts for naught. We find that in the majority of cases the machinists, etc., working under the roundhouse foreman's supervision are receiving the equivalent, if not more, compensation for their work than he, and they are not willing to accept his position, which carries with it the responsibility which he is forced to assume. The consequences are that some time in the future the roundhouse foreman will not be a competent man. He gives up most of his time to his work, but notwithstanding this, the instances in which he receives even words of appreciation are extraordinarily rare, and it appears that the time is opportune to begin at once to give him his just dues.

Efficiency.—Roundhouse efficiency can be practiced most successfully when the work can be specialized and each operation on an engine can be assigned to some workman who is competent to handle it in every detail. One of the most important duties is to secure all information the enginemen have to offer as to the condition of their engines. Roundhouse efficiency is developed from the organization maintained and by having facilities and tools necessary to do the work the quickest and in the most economical method. An organization chart for a roundhouse which turns 1,000 engines per month and handles all light repairs for a division of 250 miles is shown in the accompanying illustration.

A properly designed work order board located at a central point in the roundhouse where all employes can conveniently mark it when their work on an engine is completed, will be of great assistance to the organization.

The report is signed by: N. B. Whitsel (C. & W. I.), chairman; H. W. Ensign (C. G. W.); Chas. Snyder (A., T. & S. F.); E. J. Buckbee (C., C. & St. L.); W. S. Whitford (C. & N. W.); S. J. Harper (Y. & M. V.); W. B. Middleton (A. C. I.), and F. R. Butler (C. & O.).

DISCUSSION

Those roads that are equipped with electric cranes in the roundhouse are very strongly in favor of them, and believe that they are indispensable. Some roads use jib cranes at the posts between the pits. A number of roads also use portable lathes, some having enough work to keep a regular machinist busy on those lathes. One road reported a very satisfactory arrangement with the drainage from the roundhouses. They provide settling boxes in the sewer line to catch the waste and sediment. These boxes are cleaned every week at a nominal cost.

Several methods were mentioned for firing up locomotives. The Illinois Central, at Memphis, fires up with scrap wood and waste. Coal is first put in the firebox all around the edges, leaving a bare space in the middle. The wood and scrap waste is placed in the middle and ignited. It is claimed that this gives very little smoke. The Nashville, Chattanooga & St. Louis puts the coal in the firebox and ignites from underneath the grate with an oil burner run in through the hoppers in the ashpan; this also has proved satisfactory. The Chicago & North Western uses shavings from the planing mill. These shavings are saturated with oil and placed upon a screen to drain. Underneath this screen there are steam pipes which dry the shavings, making them easier to handle and not using as much oil.

Those roads that are cleaning their engines by washing with a mixture of oil and water under pressure find that the work is done very satisfactorily. The Delaware, Lackawanna & Western can clean a large Mikado engine by this process for not more than 30 cents, in about 15 minutes. A mixture of 75 gal. of water to 1 gal. of oil is used with a pressure of 90 lb., the pressure being taken from the air line in the shop yards. In summer cold water is used, and in winter and late fall, hot water. This method of cleaning not only gives the locomotive a very neat appearance and does the work economically, but it

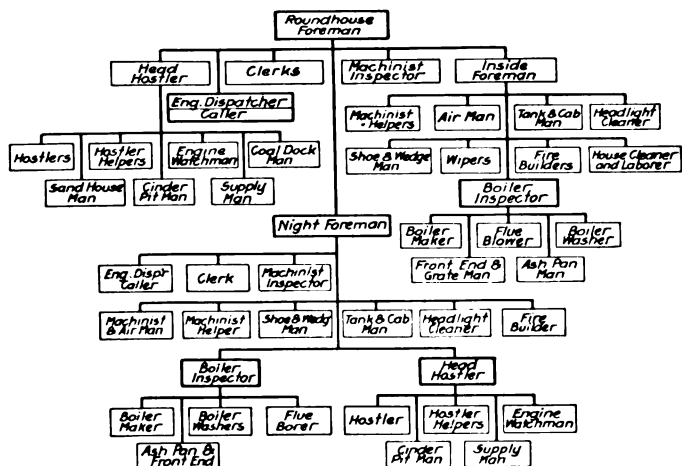

Organization for an Engine House Turning 1,000 Engines Per Month

ing the tread wear, renewing side rod bushings and knuckle pins whenever necessary and in numerous other ways keeping the engine in good condition.

Engine failures are subjects for criticism from the president down to the foreman. The traveling public are very critical in their opinions of railway management and do not hesitate to publicly denounce a railway company who has a failure causing delay to a passenger train. Competing lines often lose passengers on account of a failure that could have been avoided by more careful attention at the roundhouse; therefore it is very important that failures be kept down to the minimum. Competent men should be selected for air brake and engine inspectors. They should be men who can appreciate what it means to have an engine failure. Perfect organization in a roundhouse is the cure for engine failures.

The Interstate Commerce Commission requirements should not be lost sight of. The rules governing safety appliances and boiler inspection should be observed to the letter. Co-operation with the interstate inspectors will tend to make the relations much more pleasant, and if the railroads show a disposi-

keeps all the parts clean and free from grease, which permits more careful inspection. One road employing this method uses no special clothing for the cleaners, and the men keep much cleaner than when they cleaned the engines by the old process.

OXY-ACETYLENE WELDING

F. H. Byers (St. L. & S. F.)—The oxy-acetylene process of welding and cutting metals has during the past few years been adopted by many of the principal railroads. It is doubtful, however, whether any of the present installments are of as great capacity as will eventually prove necessary to handle the volume of work which can be most efficiently performed by this process. As far as is known, the largest single oxy-acetylene installation is that at the Springfield shop of the St. Louis & San Francisco. This plant, in addition to the ten others on the Frisco system, was furnished and installed by the Oxweld Railroad Service Company. The oxygen generators are of the duplex type and 1,000 cu. ft. capacity. The oxygen used is purchased from the Linde Air Products Company, being delivered to the road in 100 and 250 cu. ft. cylinders. These are connected to a duplex manifold which makes it possible to remove and replace cylinders without cutting off the gas supply to the shop. In all of the Frisco plants the oxygen and acetylene gases are piped throughout the shop, stations being placed at convenient intervals to serve the various departments.

The only trouble which has ever been experienced with oxy-acetylene welds has been due to the inefficiency or inexperience of the operators. On the Frisco welders are selected from the best journeymen of the various trades. No handy-men or apprentices are used on any class of work whatever. The mechanics who are selected are given a four months' course of training under an expert. By this system a corps of more than seventy expert welders has been trained on the Frisco system, and the work which is being turned out of the shops is of first quality. The Frisco, with first-class boilermakers as burner operators, is handling all classes of boiler work with unvarying success. When a firebox is to be renewed complete it is cut in sections and the staybolts and radial stays are burned off; the bolt heads remaining in the wrapper sheets are then burned out. By this process an entire box can be removed by two operators in less than 20 hours. It is the present practice to weld in all part sheets, whole sheets and seams of complete boxes. This method is more economical than riveting as to initial cost, and also represents a great saving in subsequent repairs required at roundhouses. The cutting torch is also used by the boilermakers for cutting holes as required in the firebox sheets, the boiler shell or the front end.

During the past two years all broken frames have been welded by the oxy-acetylene process, which has proven itself not only cheaper, but more satisfactory than any method previously used. There have been no failures on frame welds when competent operators, usually blacksmiths, were used.

This process has no limitations as to classes of metal; brass, cast, malleable and wrought iron or steel being welded with equal facility.

The principal use of the oxy-acetylene torch in car work, as so far developed, consists in the welding of cracked or broken bolsters, the repairing of couplers, and as an aid in steel under-frame work. The cutting torch has proven exceptionally useful in cutting off rivets in steel underframes; this work being accomplished much more quickly and at a less cost than with the air hammer.

Not the least important field to which the oxy-acetylene process has been applied is in the expedient and economical repairing of shop machines and tools and work equipment. Where ordinarily it would be necessary to order a new part from the factory, or at great expense forge out and machine a new part, it is now possible to make effective repairs in a short time, putting the machine back in service before its absence has been

seriously felt. Serious delays to work in progress are often occasioned by the disablement of certain work equipment through the breakage of parts, for which no duplicates are carried in stock. The oxy-acetylene process has made possible repairs to such machines with the minimum delay.

Old fireboxes, boilers, engine tanks, car frames and other heavy units of scrap material are often unsalable, or if they can be sold at all will scarcely yield a sufficient amount to pay for their transportation. With the cutting burner such articles as these may be reduced to convenient size for loading and handling, in which form they are readily disposed of at a fair price. This class of operation yields a large unit profit on the expenditure.

I. C. Newmarch (N. Y. C. West)—The Collinwood shops, located on the Erie division of the New York Central, use both oxy-acetylene and electricity for welding. Both have their advantages. The oxy-acetylene process is used principally for boiler work in welding or cutting. All our three-quarter side sheets, three-quarter door sheets, corner patches and such work is done with the oxy-acetylene process. We have also used it in welding up broken frames in the erecting shop, and have had fairly good success in most cases.

The electric process has its disadvantages and advantages in boiler repairs, and a careful study of each job should be made before using this method in making boiler repairs. Electric welding is here to stay and no up-to-date shop should be without it, for it is of great value in welding side sheets, door sheets, corner patches, cracked mudrings, filling up worn spots on sheets, washout plug holes and welding up small cracks in sheets up to six inches long. It is also successful in the welding of tubes in fireboxes. It is at a disadvantage in welding cracks in fireboxes over 8 in. long.

In preparing sheets and cracks for welding the best of care should be taken to get good results, first by beveling both edges of the sheet or crack 45 deg. Leave them open 3/16 in., so as to get the weld through the sheet. In building up thin spots or reducing the size of holes all scale or grease should be removed, as clean sheets insure good welding. All welds should be built up from 1/16 to 1/8 in. above the sheet to strengthen the weld.

The welding of tubes, if properly done, will reduce trouble to a minimum. First apply the tube in the same manner as if no welding were being done, except that no oil should be used on the tools in working the tubes, for electric welding is unsuccessful if there is oil on the work.

Care should be taken to see that the voltage is not too high. High voltage makes it easy for the operator, but it is not good for the tubes, as the operator with the high voltage keeps the metallic pencil 1/2 in. to 5/8 in. from the sheet, and the metal only sticks and does not weld. A voltage of 64 volts and 125 amperes makes the operator get within 3/16 in. of the sheet, assuring a good weld.

We reclaim all kinds of pieces, such as wheel centers with broken spokes, brake heads with lugs worn off, guides that are worn on the side and main rods that are worn on the side at the front. We can make a saving of from 20 to 70 per cent; in fact, it would be impossible for us to get along without this method.

J. M. Kerwin (C. R. I. & P.)—On the Rock Island for all heavy work such as locomotive frames we use Thermit and have also welded cast steel guide yokes with Thermit with very good success. During the year 1914 there were 82 Thermit welds made on frames at the Silvis shop, and up to date none have been found broken through the Thermit weld.

For light work such as boiler and tank sheets and small broken castings we use the electric and oxy-acetylene process and have found that the electric is the best for boiler work in welding patches and cracks, but the oxy-acetylene is best for cutting. The patches should be as nearly circular as possible.

We have repaired cracks running from the door hole rivets to the mudring. These have been electrically welded, the staybolts being removed, the holes welded up and redrilled. The welding of superheater flues and cracks in the knuckles of the tube sheets has also been successfully accomplished. We have also applied door collars and saved the application of new door sheets. The following shows the cost of applying door collar complete and the cost of applying a new door sheet:

Cost of applying door collar on average engine.....	\$ 50.13
Cost of electric power on average engine.....	2.52
Cost of electric welding sticks.....	3.51
Cost of applying door collar material.....	12.67—\$ 68.83
Cost of new door sheet, complete.....	200.00
Cost of new door sheet material.....	44.00— 244.00
Total saving, \$175.17.	

In the machine shop we have used the electric welding process for filling in frames worn by spring hangers, building up stock on worn spring hangers, welding rim keys in driving wheels, cracked parts of motion work, new teeth on reverse lever and throttle quadrants. We have also welded flat spots on drivers and had very good success with it; also shelled out spots on cast steel wheels. With the acetylene process we have welded ports in valve seats that were broken out; this was done with brass sticks and a flux. We have also welded bells and all kinds of cracks in pipes with copper and iron.

DISCUSSION

F. A. Byers (St. L. & S. F.)—We have welded frames 4½ in. by 13 in. by the oxy-acetylene process using the No. 10 nozzle. On a large frame we use four blacksmiths and pre-heat to a good cherry red and expand from 5/32 in. to ¼ in. Each man works 30 minutes. They weld from the inside and outside at the same time. When we weld the top rail of a double rail, before we take out the jacks or wedges used to give the proper amount of expansion we heat the bottom rail to a cherry red and have good success. If we can we reinforce the weld nearly 2 in. all the way around. We start at the bottom and weld up, placing a ½ in. piece of iron underneath to start the weld, to make it stick on the start. We have welded 177 frames and had five failures and three of those failures were on the same engine. We welded it three times. After the frame is cut it is trimmed out by a machinist. Last month the cost of welding and cutting was \$1.37 an hour for labor and material. We pay 45 cents an hour for welders.

When welding a frame the welders are on the job from the time it is hot until it is finished. We carry pressures of 50 lb. in the oxygen and 3 ounces in the acetylene. We are using one-fourth in. No. 1 rolled steel for the welding material. When the weld is large it is sometimes necessary to reheat the frame. We also remove fireboxes by cutting the staybolts with the cutting torch. It takes patience to get the scale off, but after a start is made it comes easily. We take them out in sections, two rows of staybolts at a time, and one man in four eight-hour days takes the complete firebox out, crown sheet and all, a total of 32 hours. Following is a list of the work we have done:

- Welding complete fireboxes.
- Welding back tube and door sheets and door collars.
- Welding in crown sheets complete.
- Welding crown seams after burning through center of rivets and rivet holes.
- Welding half side sheets and not removing mudring rivets; cutting sides above mudring, also tube and door sheets in the same way when in good shape at the mudring.
- Welding three-fourth front tube sheets, not removing steam pipes.
- Welding patches in fireboxes and outside casing sheets, and building up worn places in sheets, mudring corners and around washout holes.
- Welding patches on top of back tube sheets.
- Welding cracked bridges in tube sheets.
- Welding up staybolt holes; this saves bushing holes and sometimes patching.
- Welding cracked mudring corners on either side, top or bottom.
- Cutting holes in roof sheets for radial stays in place of drilling, reaming holes, after burning, with reamer and spindle.

- Cutting out fireboxes complete, and parts of boilers.
- Cutting superheater flues.
- Cutting out countersunk rivets and removing rivet heads.
- Cutting off staybolts and cutting out staybolts for removal of broken bolts.
- Burning out staybolt burs in place of drilling or punching.
- Cutting off staybolt ends for driving.
- Cutting off radial stay ends for driving on both sides in place of having them set.
- Cutting around tubes on back tube sheet when back end is to be removed, taking part of tube sheet and removing tubes from the boiler with traveling crane.

H. Eisele (Wabash)—In removing fireboxes we cut them up in strips 18 in. to 20 in. wide for the full length of the inside of the box with the cutting torch, the staybolts being drilled on the outside. After the boiler is removed the firebox is taken to the boiler shop and laid on its back and clamped. A big crane is then used to pull out the strips.

G. H. Logan (C. & N. W.)—We cut out the firebox in sections, using a long cutting torch. After a good sized hole is made, one-fourth of the sheet can be cut out at one time. The crown sheet is removed last.

Mr. Byers—The cutting is the most profitable process in the shop. We never drill a hole on steel running boards. A five-piece firebox was welded before application at a cost of \$527.24 labor and material. The holes are drilled for the mudring before the side sheet and the door sheet and tube sheet are welded in. When a tube sheet or door sheet warps after being welded it is heated and pulled back to shape. We have 57 fireboxes in service that are entirely welded—no seams in them—and we have no trouble with them. When we put in a patch we put in a round one and dish it slightly along the edges. The welder starts at one end and keeps a little wedge driven ahead of the hammer. We do not weld any bridges in back tube sheets. We cut the small tubes out of the boiler with a light steel roller and the large ones with acetylene. We have welded 15 sets of tubes at the firebox end and did not have very good success with them. We have still got 6 or 7 of the 15 in service. One of them has made 90,000 miles and another one 75,000, but they are both ready for shopping. We are still experimenting on welding tubes with oxy-acetylene. We apply our staybolts from the inside of the firebox, and one cutter can cut the entire firebox in six hours. That leaves them nice and square and they are set and ready to drive. We weld the staybolt holes in the outside casing in order to reduce the size of the hole. Tire steel chips are used for filling in flat spots.

CLOSING EXERCISES

During the Thursday session an address on the "Selection of Men and Their Promotion," was made by Roy V. Wright, editor of the *Railway Age Gazette, Mechanical Edition*. The necessity of having the officers and foremen study their men more critically was emphasized. An address on the same subject, which was made in Chicago, June 28, is printed on another page.

The following officers were elected for the ensuing year: President, L. A. North, superintendent of shops, Illinois Central, Chicago, Ill.; first vice-president, Walter Smith, general foreman, Chicago & North Western, Deadwood, S. D.; second vice-president, W. T. Gale, foreman, Chicago & North Western, Chicago, Ill.; third vice-president, W. G. Reyer, general foreman, Nashville, Chattanooga & St. Louis, Nashville, Tenn.; fourth vice-president, C. L. Dickert, assistant master mechanic, Central of Georgia, Macon, Ga.; secretary-treasurer, William Hall, foreman, Chicago & North Western, Winona, Minn.

THE COST OF EMPLOYING INCOMPETENTS.—At a recent gathering of machine tool builders it was stated that it costs \$30 to \$35 to engage a workman, test him and discharge him if inefficient. This figure is based on the records of a large manufacturing plant, and it is easy to see how much can be lost per annum if great care is not exercised in selecting the new hands.—*Power*.

NEW DEVICES

PLANT FOR SANDBLASTING STEEL CARS

To meet the demand for an effective and economical means of cleaning steel cars from mill scale, rust, paint, etc., the sand blasting plant shown herewith has been developed by the Mott Sand Blast Manufacturing Company, New York and Chicago. In designing this system the purpose has been to so arrange the apparatus that the sand may be handled by gravity, thus eliminating the use of elevating machinery, and reducing the cost of the structure required to house the equipment, and to provide an effective system of ventilation with a minimum expenditure of power.

The plant is installed in a building consisting of a sand blast room 12 ft. long inside, and of sufficient width to allow operators to work on both sides of the car, to each end of which is connected a shelter bay of sufficient length to house a car of the greatest length which the plant will be required to handle. The portion of the building containing the sand blast room is a two-story structure with a basement, the latter containing the sand blast machines and the motor-driven double exhauster, while the second story contains the dust arrester.

The openings between the sand blast room and the shelter

filling valves, and by this arrangement all elevating machinery is dispensed with. Sectional grating platforms extend along either side of the room, near the bottom of the car body. These are for the use of the operators working on car bodies; in order to provide access to the underframes or the trucks, or to make the room available for cleaning structural work the sections are hinged to the side walls so that they may be either in part or all raised against the sides of the building.

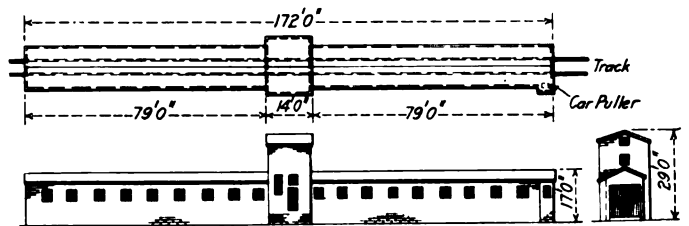

Type of Building Required to House the Mott Sand Blasting Plant

The dust arrester in the second story of the blast room is of the manifold cloth screen type and removes all dust from the air passing through it. Hoppers for the collection of the dust

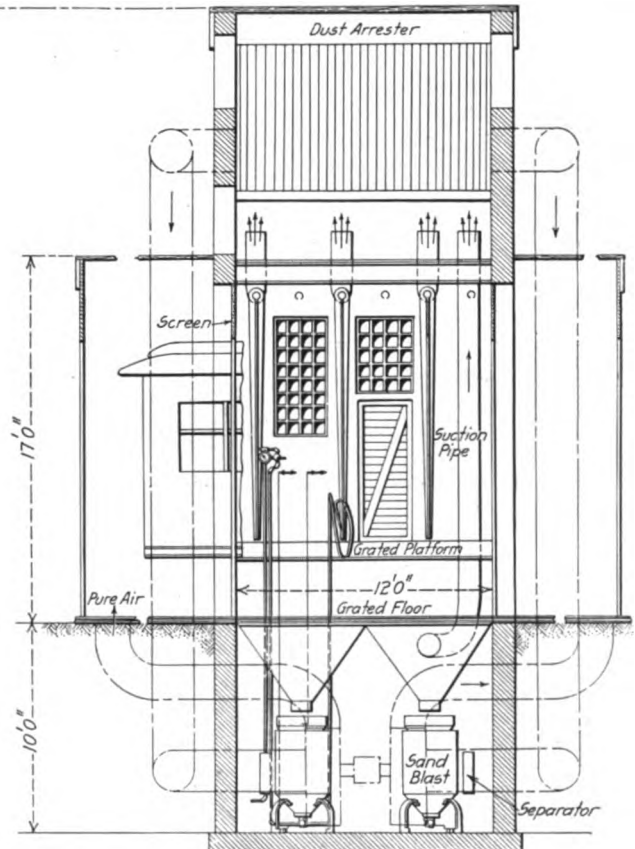
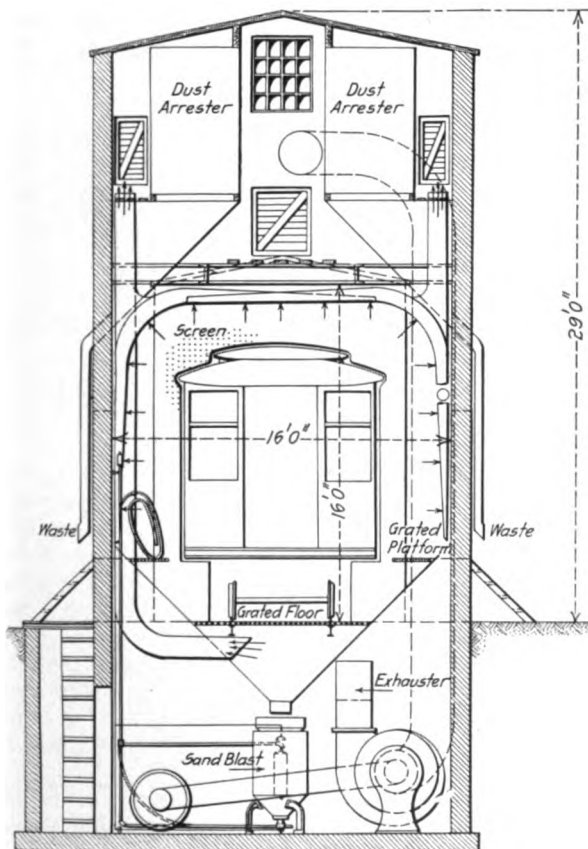

Sectional Views of the Sand Blasting Room, Showing the Arrangement of the Apparatus

bays are closed by soft curtains designed to conform closely to the outline of the sides and roof of the car. The entire floor of this room is a steel grating, below which are hung two steel hoppers for collecting the abrasive material as it drops from the cars and directing it to the top of the two sand blast machines, one of which is placed directly below each hopper. The sand blast machines are fitted with screens and automatic

are built in below the screens, and are suitably connected to waste chutes extending out through the sides of the building. Suction pipes from the dust arrester lead to a double exhauster in the basement below the blast room. The cleaned air is discharged from these exhausters into the shelter bays, about 10 ft. back from the blast room, thus causing a slight increase of pressure in the shelter bays and inducing a steady flow of air

from them into the sand blasting room. The air passes through the small openings between the curtains and the car body and prevents dust from entering the shelter bays. To the intake side of the dust arrester are connected a number of pipes with slotted openings running down either side of the room and across the roof of the car. Eight of these branches are used, and through them the dust is collected and withdrawn to the arrester. Other suction pipes are placed in the hoppers above the sand blast machines for withdrawing the dust from below the floor.

By closely confining the sand blasting operations in a 12-ft. room and by collecting the dust close to its point of origin it is possible to secure adequate ventilation with a low requirement for power. It is claimed that only 25 hp. is necessary to effect eight changes of air per minute in this room. The ventilation is also materially benefited by the return of the clean exhaust from the fans into the shelter bays on either side of the sand blast room.

The sand blast machines are fitted with $\frac{3}{8}$ -in. or $\frac{1}{2}$ -in. nozzles, and when supplied with air at a pressure of 80 lb per sq. in. will clean from four to eight square feet of surface per minute, or a total of 8 sq. ft. to 16 sq. ft. per minute for both machines. The apparatus is designed to use any abrasive material, preference being given to metal abrasives as being cheaper and decreasing the amount of dust created.

SMALL STEAM DRIVEN AIR COMPRESSOR UNIT

The demand for higher efficiency and the increasing tendency toward the use of higher steam pressures has led to the development of a new type of small steam driven, half-speed air compressor by the Ingersoll-Rand Company, New York. This machine is similar in general design to an older small steam unit built by the same company, but embodies a number of improvements which are claimed to give it a higher efficiency in the air end and a considerably lower steam consumption.

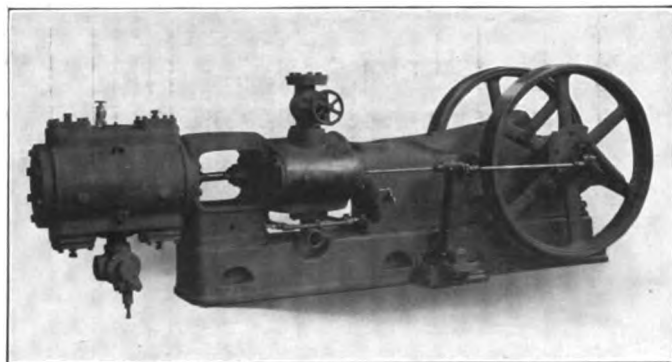

Small Air Compressor Unit

The air valves used on this compressor are of the recently adopted Ingersoll-Rogler type and are independent of any operating mechanism. They give high compression efficiency, and are almost silent when operating at high speeds. Before adopting this valve a thorough test was conducted to determine its life. This test consisted in running a 12-in. stroke compressor 400 revolutions per minute over a period of one year, during which time no valves were broken and no adjustments required.

The distribution of steam is controlled by balanced piston valves. This type of steam valve was adopted to facilitate the operation of the unit at higher speeds, and with high steam pressures; it is also adapted to the use of superheated steam. The automatic cut-off control is regulated by a centrifugal fly-wheel governor which shortens or lengthens the stroke of the

piston valve. This is supplemented by an automatic air un-loader.

In the design of the machine as a whole materials are disposed with special attention to secure rigidity without excess weight and special provision has been made for ready adjustment of all parts, without loss of time. The bearing parts are oiled by an automatic splash system of lubrication.

LEVER HAND BRAKE

A freight car hand brake in which the usual type of brake shaft and wheel is replaced by a tension rod and lever has now

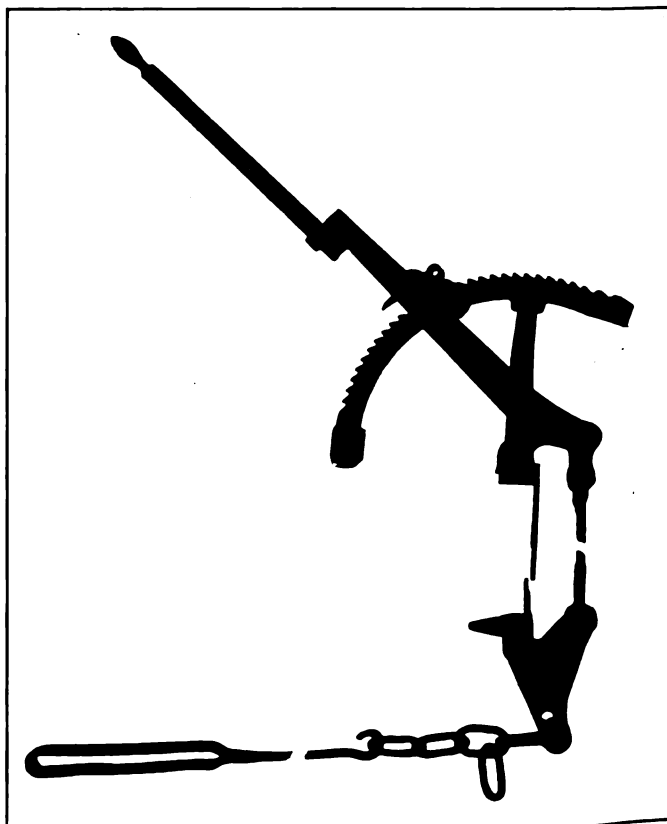

Details of Lever-Operated Hand Brake

been in service on a number of cars for more than a year and a half. It is known as the Klasing car brake and is operated by a lever having an extension handle, to which is secured a pawl engaging ratchet teeth on a vertical quadrant. The lever is pivoted to the quadrant and the latter is secured to the top of the car so that the short end of the lever projects over the end of the roof. A bell crank is secured to the end sill directly below the end of the operating lever to which one of its arms is connected by a tension rod. The other end of the bell crank is connected to the brake rod, which is provided with an adjustable jaw for taking up slack.

The purpose of this design is to facilitate quick action in the application of the brake and it is claimed to eliminate an element of danger to the brakeman incurred in changing his position when operating the usual type of hand brake. The pawl is controlled by a small weight, thrown forward by hand to engage the ratchet.

This brake is sold by D. R. Niederlander, successor to the Adreon Manufacturing Company, Security Building, St. Louis, Mo. It may be applied to the top of box cars, to the top of gondolas and to the end sills of baggage and tank cars, and it

is equally suitable for application to box or gondola cars with end steps. The travel of the bell crank is 13 in. which is more

pipe. This is due to the fact that the die head and gripping chuck have universal diametrical adjustments, and but one set of chasers is required to cover the range of each die head.

Size	Range	Number of Heads	Standard Chaser Equipment
4 in.	1 in. to 4 in.	2	1 set 11½ pitch 1 set 8 pitch
6 in.	1 in. to 6 in.	2	1 set 11½ pitch 1 set 8 pitch
8 in.	2½ in. to 8 in.	2	1 set 8 pitch (2½ in. to 4 in.) 1 set 8 pitch (4 in. to 8 in.)

The accompanying table gives the principal data for the different sizes of the machines. The machines are fitted with reaming attachments and cutting off tools, and the makers claim they will thread, ream and cut pipe in one continuous operation at a speed double that possible on any other pipe machine. Several of these machines have already been placed in service.

ROLLED STEEL TRUCK FRAMES

The American Car & Foundry Co., New York, has developed designs of four-wheel and six-wheel trucks for passenger service, having frames made up almost entirely of standard rolled

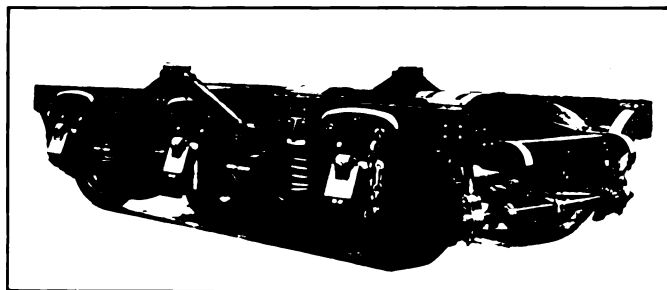

Six-Wheel Truck with Rolled Steel Frame

sections. The idea in designing these trucks was to reduce both first cost and maintenance troubles. Repairs to the frames can be made at almost any shop and experience has shown that under ordinary service conditions, heavy repairs requiring special work and tools are unnecessary.

In both designs the attempt was made to secure maximum strength and service ability with a minimum weight. The frame for the four-wheel truck weighs approximately the same as the old wooden frame having iron flitch plates, while there is a marked advantage as regards strength and rigidity. All rivet holes are reamed to size and the more important rivets

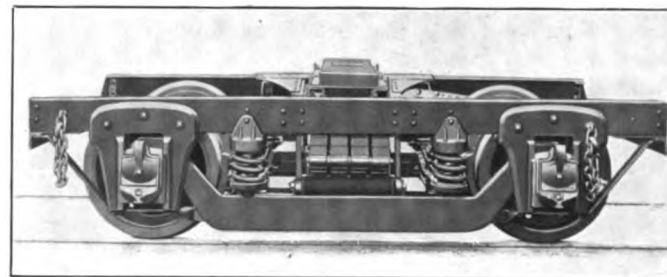

Four-Wheel Truck with Rolled Steel Frame

are machine driven. Large gusset plates are used to connect the cross members to the truck sides and the friction plates for the bolsters are located on the bolster hanger brackets, thus removing the lateral strain from the cross members. The brake hanger bracket is secured to a pressed arm, which is supported by the truck side and the cross member gussets. The bolster hanger is extra long and the pins are of large diameter in order to reduce wear. Either the usual design of inside

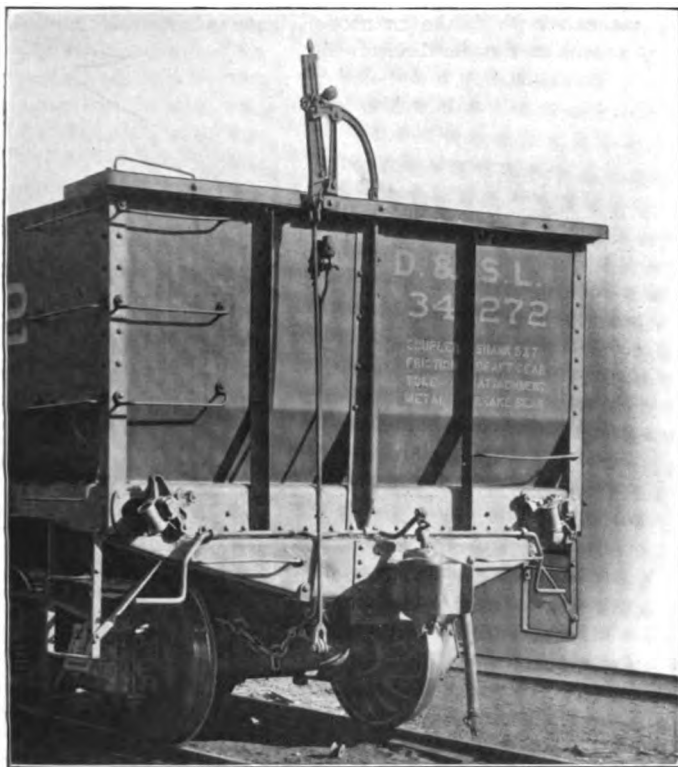

The Brake Applied to a Gondola Car

than provided by the air brake. The maximum height of the lever above the roof of a box car is about 15 in. with the extension handle collapsed.

PIPE THREADING AND CUTTING MACHINE

The Landis Machine Company, Waynesboro, Pa., has recently developed and placed on the market a line of pipe threading and cutting machines, which are attracting considerable attention. These machines are designed to use the Landis stationary type pipe die heads, which cover a wide range with but one set of

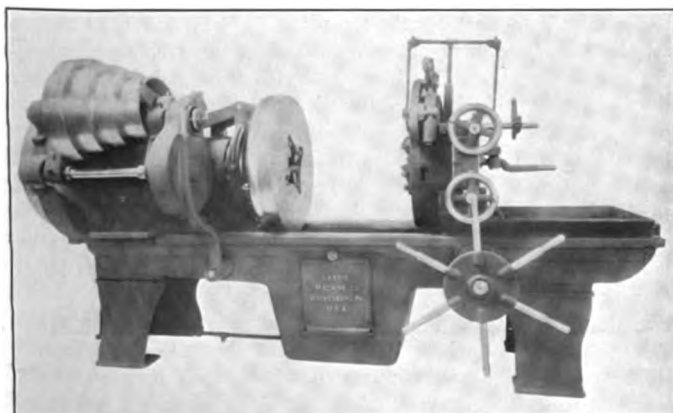

Machine for Threading and Cutting Pipe

chasers. The gripping chucks have universal adjustments and on the 4 in. and 6 in. machines are lever operated.

The most noteworthy feature of this type of machine is the ease with which it may be adjusted for the different sizes of

hung brakes or the American Brake Company's design of clasp brakes may be used with this truck.

The six-wheel truck has been found to meet all the requirements of high-speed passenger service, trucks of this design having been used for some time under heavy passenger equipment cars, including dining cars. It is claimed that frames for the six-wheel truck are approximately 3,000 lb. lighter per car than the usual design of cast steel frame, this advantage being obtained because in the rolled steel design the metal can be placed to better advantage at the points of greatest stress. The American Brake Company's clasp brake arrangement can be used with this truck, as well as with the four-wheel design.

EXTENSIBLE VESTIBULE TRAP DOOR

The Pennsylvania Railroad has built high station platforms at its New York terminal, at Manhattan Transfer, Rahway and North Philadelphia, and has similar platforms under construction at Wilkinsburg and Johnstown on its Pittsburgh division. It is often impossible to build tangent platforms, owing to the physical conditions at stations and a difficulty has arisen in connection with the adoption of the high platform where it is built

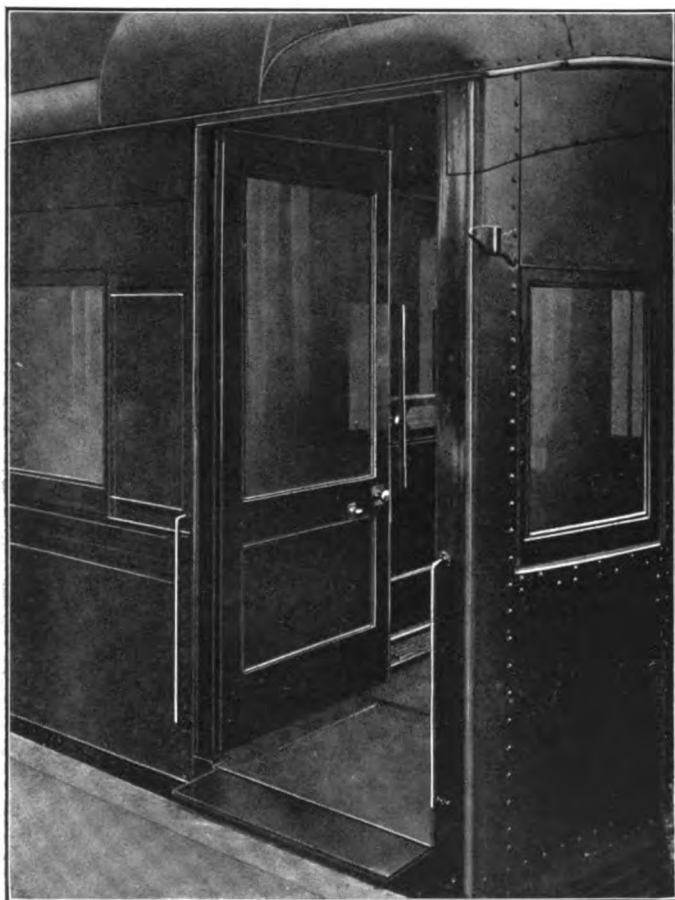

Trap Extended at a High Station Platform

on a curve, owing to the gap between the car and the platform. With a view to overcoming this difficulty the Pennsylvania has equipped for trial a steel vestibule car with an extensible trap door patented by Elwood H. Sickles, 213 Woodside avenues, Narberth, Pa., which is designed to bridge the gap between the car and the station platform. The operation of this device is practically automatic. When the trap is down the opening of the vestibule door causes the sliding portion to extend beyond the side of the car; closing the door returns it to its normal position. When the trap is to be raised for the use of the

step, or when the brakeman opens the door while the train is moving the trap should not be extended. To provide for this feature a small handle is set flush in the end of the car body, by means of which the connection between the door and the trap extension may be disengaged.

The extension trap in outward appearance is like the ordinary trap, and consists of a rubber covered top plate *A* and an ex-

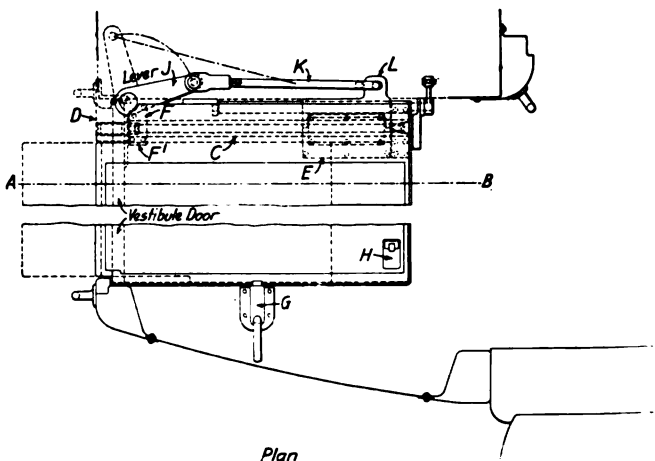
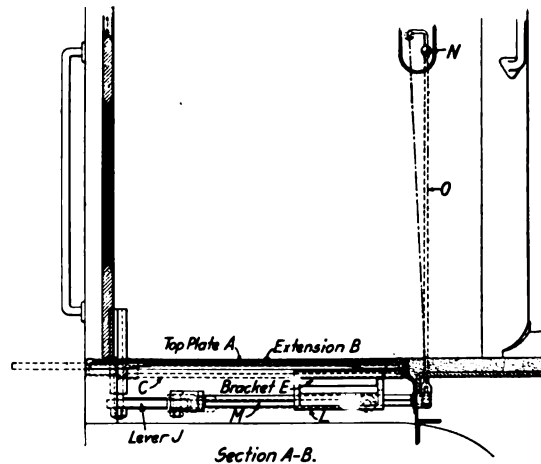

Arrangement of Sickles Extensible Trap Door

tensible portion *B*, which is built in the familiar panel pattern and acts as a support for the top plate. The two parts are hinged on the rod *C* so they act together when the trap is raised for the use of the step. The hinge rod is hollow and accommodates the flat springs which are adjusted at the bracket *B* to obtain the proper tension. The extensible portion of the trap is supported by bracket *E*, which slides on the hinge rod and lug *F'* attached to the top plate bracket *F*. When the trap is extended, owing to the fact that it is supported at one side on lug *F'*, and at the opposite side on the usual angle iron ledge, the extended portion is prevented from deflecting when a passenger steps on it. Spring catches *G* and *H* of the usual type are used to hold the trap door down when the door is closed and to hold it up against the vestibule door when it is raised for the use of the steps.

The operating device consists of a bell crank lever *J* attached to the bottom of the vestibule door, the connecting rod *K* and the cam *L* which slides on the square shaft *M*. The rod shown at *O* is attached to the end of a lever which turns the square shaft. The upper end of this rod extends through a slot in the end of the car and is provided with a knob by means of which it may be raised to the position shown by the dot and dash centerline, or returned from that position to its normal position as shown in the drawing. In the latter position the cam *L* on the

square shaft engages a taper lug on bracket *F*, through which the trap extension is moved by lever *J* and connecting rod *K* when the door is opened. When the knob *N* is in its upper position the cam is disengaged from the bracket on the extension and opening the door has no effect upon the trap. The cam is so designed, however, that when released its front finger is always in position to prevent the trap from being extended independently, thus making it impossible for the trap to be out when the door is closed. The trap is so arranged that it is impossible to raise it when extended, due to interference between the corner of the extension and the hinge bracket *D*. The trap is designed with a uniform extension to take care of the gap at platforms built on curves as sharp as 6 deg. On lighter curves the extension may slightly overlap the platform, the latter, of course, being kept a small step below the floor of the car. Owing to the varying height of the car floors above the top of the rail, due to differences in springs, etc., it has been found impossible to maintain the car floor at a level with the station platform.

It is unnecessary to provide extra trainmen to attend to the operation of this trap, as with the small hand lever set in proper position, the opening of the vestibule door, whether accomplished by the trainman or passenger, will cause the trap to extend. Owing to the fact that the stop plate does not slide, it is, of course, impossible for passengers to be thrown by the movement of the extension.

BRAKE BEAM SAFETY HANGER

The accompanying drawing shows a type of brake beam safety hanger which has recently been patented by Edward O. Elliott, chief draftsman, Philadelphia & Reading, Reading, Pa. The device is extremely simple and offers practically no obstruction to the removal and replacement of the beam.

The safety hanger is attached to the spring plank and under normal conditions is entirely free from contact with the brake beam or brake head. It consists of a rectangular bar 2 in. by 3/4 in. in section and 32 in. long. This is supported by two

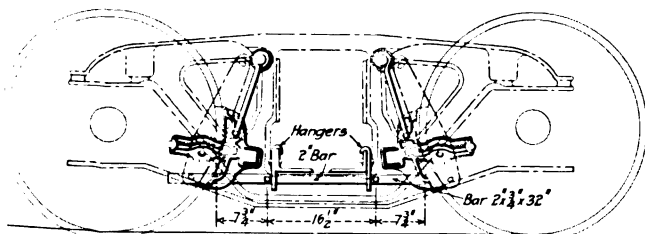
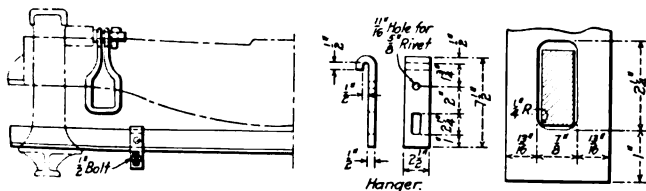

Brake Beam Safety Bar Attached to a Truck

hangers lipped over the vertical flange of the spring plank and riveted to it. These are shown in detail in the drawing. The bar is slipped into place through slots in the hangers and secured by means of 1/2-in. bolts placed through the bar at either end just outside of the hangers. In this position the device offers effective support to the brake beam should the brake-beam hangers fail. Should the removal of a brake beam be desired the bar may be slid back at one end as shown in the drawing by removing one of the 1/2-in. bolts, in which position it offers no obstruction to the removal of the beam.

This safety hanger is in use on the Philadelphia & Reading.

SIMPLE COUPLER RELEASE RIGGING

The coupler release rigging shown herewith was designed to eliminate as many parts as possible and to facilitate the application of the device to the eye of the coupler lock and the end of the car. It is known as the Singlelink release rigging, from the fact that but one piece is used between the uncoupling lever and the eye of the coupler lock. The upper end of the link is made with an elongated eye, which provides for all motion of the coupler relative to the end sill, and the lower end is provided with an open eye.

The uncoupling lever is secured to the end sill of the car by means of open brackets which are closed by cotter pins. In applying the rigging to the car the lower end of the link is

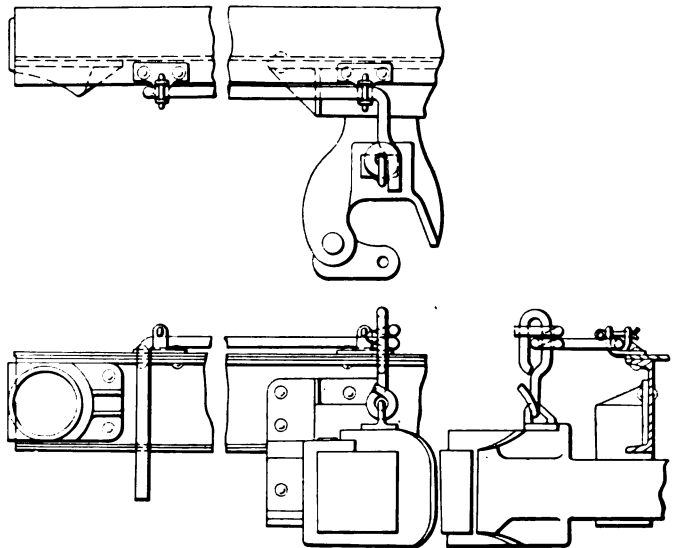

Coupler Rigging Having Few Parts

first hooked into the eye of the coupler lock; the lever being then placed in the brackets and secured by the cotters. The lever connection to the link is provided with a tail which serves to prevent the link from turning and sliding out of place.

HULSON LOCOMOTIVE GRATE

A large total air opening in locomotive grates with not too wide an opening between the fingers of the grate is an acknowledged advantage. At the recent convention of the International Railway Fuel Association it was stated that from a canvass of 21 roads, it was found that the percentage of the area of the air openings in the grate to the total grate area varied from a minimum of 28.5 per cent. to a maximum of 49.6 per cent., and that the average was 37.2 per cent., with 1 in. openings between the fingers, for bituminous coal burning engines. It was also stated that the Seaboard Air Line strongly favored the table grate on account of its large air opening.

The illustrations show a grate for locomotives which provides an air opening area of 55 per cent. of the total grate area, with 5/8 in. openings between the fingers, and with possibilities of a larger percentage of air space where the conditions permit. This grate is made by the Hulson Grate Company, Keokuk, Iowa. It has been installed in a large number of stationary plants and has been made standard on the locomotives of one railway. The experiences of those who have it in service indicate that with the large amount of air opening in the grate it has been possible to more thoroughly consume the coal, thus producing less smoke and keeping cleaner fires. Many cases have also been found where a cheaper grade of fuel can be

used with this grate. Because of the better consumption of the fuel several of the users report considerable savings in coal consumption.

Aside from the large amount of air space provided by this grate the mechanical features are of considerable interest, the purpose of the manufacturers being to provide a grate of as simple construction as possible, with a minimum amount of trou-



Parts of the Hulson Grate

ble to repair. The details of the grate are shown in one of the illustrations. No. 1 is the side bar; No. 2 the tie bar; No. 3 the finger bar, and No. 4, the finger. The fingers are all loose on the finger bar, which permits expansion or contraction without affecting the finger bar. The fingers slide on to the finger bar from the end, being held by means of a key cast into the bar and fitting into a keyway in the fingers. This construction has been adopted to make possible the renewing of the fingers, should they become broken, at a very small cost, the finger bar simply being lifted from the side bar and the broken finger replaced. It will also be noted that the tops of the fingers are

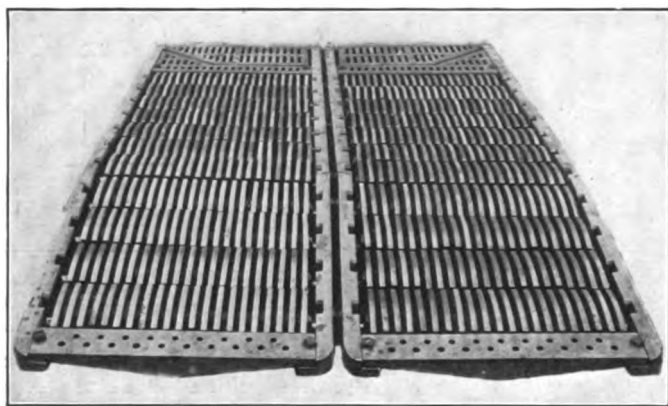

Hulson Grate for 108 in. by 66 in. Locomotive Firebox

curved so that when the grate is rocked slightly, a rubbing action will be produced on the fuel bed which dislodges the fine ash without disturbing the fire or allowing the unburned fuel to drop into the ashpan. By shaking the grate for the full stroke, however, it is possible to dump the fire. The construction of these fingers also tends to raise the bed of the fire sufficiently high from the mechanism of the grate to keep it from being subjected to the severe heat. It is also claimed that the large percentage of air space in the grate permits the use of a larger exhaust nozzle, since as much draft will not be required to pull the air through the grate bars. With the $\frac{5}{8}$ in. openings there will be a more even distribution of the air through the fuel bed, which permits of a lighter fire being carried.

RAILWAY EXTENSION IN CHINA.—The Chinese Government proposes to construct railway lines outside the Great Wall. The termini of the proposed lines are the several places which will be opened as trade ports, such as Chifeng, Taonanfu, Dolonor, etc. The first line is from Peking to Jehol, a distance of 140 miles, with a line from Jehol to Chifeng of 130 miles, and another one of 170 miles from Chingchow to Chifeng. The other lines are from Kalgan to Dolonor of 150 miles, and from Dolonor to Chifeng of 200 miles. These lines will be connected with the Peking-Mukden and the Peking-Kalgan railways. The scheme is now under consideration by the Ministry.

EMERGENCY JACK WITH ADJUSTABLE BASE

The jack shown in the illustration is adapted to a variety of purposes about the shop, on the repair track and in emergency use generally. It is known as the Simplex emergency jack and is manufactured by Templeton, Kenly & Co., Ltd., Chicago.

The standard or frame is a heavy malleable iron casting well reinforced with ribs against stresses in all directions. It is hinged to the base by a steel pin, which is relieved of shearing stress by the fitted circular bottom of the frame, which rests upon shoulders in the base. The rack bar and cap are of heavy drop forgings, the top of the cap being recessed to fit the links of a chain, which may be used in shifting heavy material.

The double socket of crucible steel makes it possible to operate

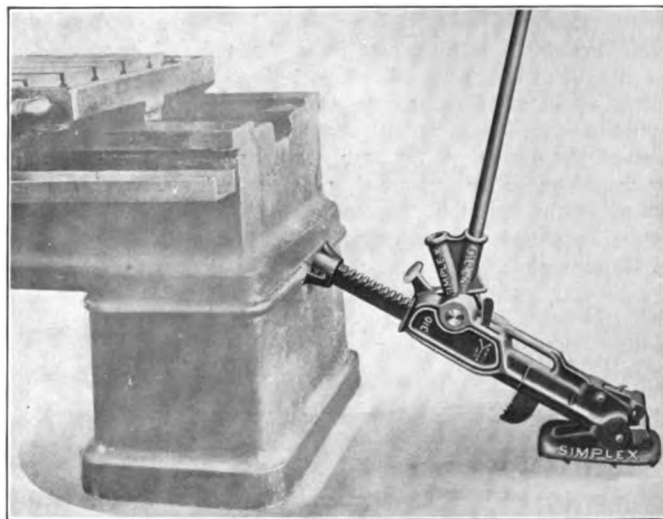

Emergency Jack with Adjustable Base

the jack at any angle from the vertical to 30 deg. from the horizontal. A heavy trunnion bearing supports the socket. A trip at the back of the base is provided to hold the frame rigid in a vertical position, the releasing of which permits the pivoting of the body on the base. The equipment of the jack includes five feet of chain and a five-foot steel lever bar. The jack has a capacity of 15 tons.

NATIONAL HOSE COUPLING

The accompanying illustration shows a new type of hose coupling recently placed on the market by the National Hose Coupling Company, Peoples Gas Bldg., Chicago, Ill. This coupling provides a positive means of applying a coupling to a rubber hose. As indicated in the illustration, the hose is inserted in the cor-

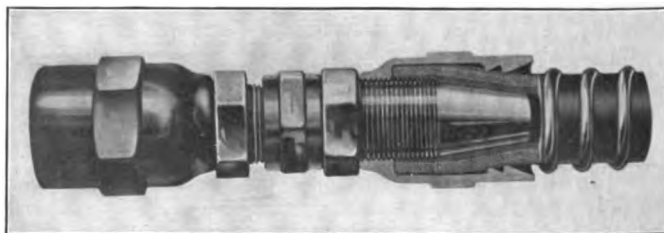

Sectional View of the National Hose Coupling

rugated socket and a steel taper expander is screwed into the socket, forcing the hose out against the corrugation. The ends of the socket and the expander are rounded to prevent injury to the hose. No special tools are required for application.

RECORDER FOR MEASURING FLOW OVER WEIRS

With any type of weir or orifice the rate of flow is dependent upon the head, and once the law of the weir or orifice is known, it may be calculated directly. For most purposes of measurement, however, mere knowledge of the rate of flow at a given



The Cochrane Flow Recorder

instant is not sufficient, but continuous or total results are wanted. This has led to the development of various types of flow recorders, one of the most recent of which, the Cochrane type, is illustrated herewith.

In such recorders there is a float which moves vertically in response to changes in head. If the motion of the float is employed directly to actuate the recording device, so that the action of the recording pen is directly as the motion of the float, or in proportion to it, a record of rate of flow can be obtained, but the divisions on the chart are not in general equal for equal increments in the rate of flow. It is therefore necessary to incorporate some kind of translating or modifying mechanism between the motion of the float and the motion of the recording pen. This translating mechanism is ordinarily a cam.

In the Cochrane flow recorder, the cam is laid out as a spiral on a flat circular plate, and the multiplying mechanism consists of a small drum mounted upon the spindle of the cam, and having wrapped about it a thin metal cable which is attached to the float spindle, a counter-weight on another cable serving to keep the first cable taut. The spiral groove is cut into the surface of the disk, and is so arranged that the part of the cam corresponding to the low heads is near the center of the disc, and the part corresponding to high heads is near the periphery of the disc. To accommodate the recorder for use with weirs of different heights it is only necessary to substitute cable drums of the proper respective diameters. One cam serves for all weirs, having the same law connecting head and flow, and

hence it has been commercially feasible to devote considerable expense to the mechanical means of reproducing this cam to insure accuracy.

The elimination of friction and back-lash are prime requisites in the design of such apparatus. Back-lash has in the present case been eliminated by the use of a cable drum instead of the gear and pinion drive formerly employed, while friction has been reduced as much as possible by mounting the spindle of the cam upon anti-friction rollers. Accuracy is also promoted by the use of a large, powerful float, and where an enclosed weir chamber is employed, and the float stem must pass through a packing gland, the latter should be of the self-aligning type.

The pen carriage is provided with large rollers or wheels, which rest upon horizontal ways, so that the cam follower which is attached to the pen carriage moves diametrically to the cam disc. The construction is such that the cam follower cannot be accidentally displaced from the cam slot. The chart being driven uniformly by a clock, the pen not only records the rate of flow at each instant, but the area under the pen trace is proportional to the total flow for any elapsed period. Many users, however, desire to obtain the total flow directly, without the use of a planimeter, and for this purpose an integrating attachment has been added.

Only one clock is employed, a powerful, weight-operated pen-

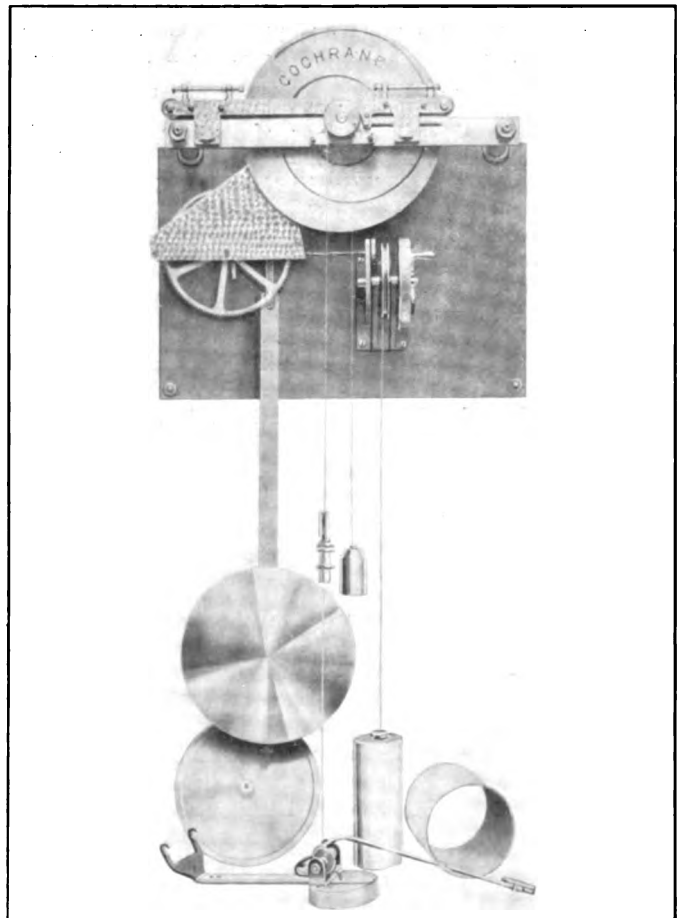

Mechanism of the Flow Recorder with Drum and Recording Pen Removed

dulum movement, making 80 beats per minute, as against the 240 or 300 usual with hair-spring escapements.

This flow recorder, while originally designed for use with V-notch weirs, may be used with rectangular weirs or submerged orifices. It is regularly supplied in connection with the Cochrane V-notch meters and metering heaters, manufactured by the Harrison Safety Boiler Works, Philadelphia, Pa.

NEWS DEPARTMENT

The Chicago & Alton has increased the working time at its shops at Bloomington, Ill., from eight to nine hours a day.

On July 22, 1915, the Grand Trunk Pacific had completed the installation of oil-burning locomotives on the mountain sections of its line and they were operated for the first time in passenger service. Oil is being used for fuel over 719 miles of main line, from Jasper to Prince Rupert, B. C.

The railway department of the American Federation of Labor has issued a notice officially calling off the strike of the mechanical department unions which was declared on the Illinois Central, the Harriman Lines and the Pere Marquette in 1911. From the point of view of the railways the strike was terminated over three years ago.

George W. Wren, a carpenter in the motive power department of the Ann Arbor Railroad at Owosso, Mich., has been in the service of that company for about 27 years and is still actively employed, although he was 55 years old before he entered the service. He is now in his 82nd year and is still actively engaged in his occupation of building and repairing locomotive pilots, hand cars and gasolene section cars.

The Erie Railroad has sold four of its largest steamships which are in use on the Great Lakes, and the ownership of which the company has to divest itself in accordance with the recent decision of the Interstate Commerce Commission. It is understood that the boats will be cut in two and taken through the St. Lawrence river to the Atlantic ocean, there to be again put together and to be used by the purchasers in the coastwise trade.

The San Pedro, Los Angeles & Salt Lake has issued to its employees a special bulletin on trespassing, urging them to begin a campaign of agitation in their individual circles of influence to arouse the public to a realization of the dangers of trespassing. The bulletin says: "The Salt Lake route is a safe road to ride upon. In the last eight years no passengers have been killed in train accidents. It is a very unsafe road to walk upon. During the same period 101 trespassers have been killed."

J. A. McCrea, general manager of the Long Island, says that it is only by the rarest chance that there was not a series of disastrous accidents to automobiles at grade crossings on that road during the week ending June 28. Every day he receives reports to the effect that the crossing gates at this or that place have been broken by drivers who thought more of speed than of safety. In that one week there were a dozen or more such cases. Mr McCrea has issued a list of these "near accidents."

In recognition of his ability in designing a special tool holder for use in the Sayre shops of the Lehigh Valley, Edward Seddon, a machine foreman, has been given a cash bonus by the railroad company. High speed tool steel is very expensive material. Mr Seddon built a device by which tool holders require only a cutting edge of high speed tool steel, thus making possible a large economy. He has also recently designed a number of other special devices for use in railway shops, and it is as a mark of appreciation of the economies he has made possible that the company has awarded the bonus.

MEETINGS AND CONVENTIONS

International Railroad Master Blacksmiths' Association.—The twenty-third annual meeting of the International Railroad Master

Blacksmiths' Association will be held at the Hotel Walton, Philadelphia, August 17, 18 and 19, 1915. The following subjects will come before the meeting for consideration: Flue Welding; Making and Repairing Frogs and Crossings; Carbon and High-Speed Steel; Tools and Formers; Electric Welding; Drop Forging; Spring Making and Repairing; Piece Work and Other Methods of Having Work Done; Making and Repairing Locomotive Frames; Oxy-Acetylene Process for Cutting and Welding; Case Hardening; Heat Treatment of Metals; Best Methods of Reclaiming Scrap; Shop Kinks; New Subjects. Committee reports on most of these subjects have been prepared for presentation at the meeting.

Chief Interchange Car Inspectors' and Car Foremen's Association.—The seventeenth annual convention of the Chief Interchange Car Inspectors' and Car Foremen's Association of America will be held at Murphy's Hotel, Richmond, Va., September 14 to 16, inclusive. As is customary, the problems in the interchange of railway cars and the M. C. B. rules governing the interchange of cars will be discussed.

Master Car and Locomotive Painters' Association.—The forty-sixth annual convention of the Master Car and Locomotive Painters' Association of the United States and Canada will be held at the Hotel Statler, Detroit, Mich., September 14 to 16, inclusive. A paper will be read by Henry A. Gardner, assistant director of the Institute of Industrial Research of Washington, D. C., on Metal Protection. Committee reports will be made on Flat Color vs. Enamel Color; Effect of the Design of Present Steel Passenger Equipment on the Protective Coating; Price vs. Quality in Buying Paint Material; Varnish Finish vs. Varnish Enamel Color; Piece Work; Maintaining the Interior of Steel Passenger Cars.

The following list gives names of secretaries, dates of next or regular meetings, and places of meeting of mechanical associations.

- AIR BRAKE ASSOCIATION.—F. M. Nellis, 53 State St., Boston, Mass.
 AMERICAN RAILROAD MASTER TINNERS, COPPERSMITHS AND PIPEFITTERS' ASSOCIATION.—W. E. Jones, C. & N. W., 3814 Fulton street, Chicago.
 AMERICAN RAILWAY MASTER MECHANICS' ASSOCIATION.—J. W. Taylor, Karpen building, Chicago.
 AMERICAN RAILWAY TOOL FOREMEN'S ASSOCIATION.—Owen D. Kinsey, Illinois Central, Chicago.
 AMERICAN SOCIETY FOR TESTING MATERIALS.—Prof. E. Marburg, University of Pennsylvania, Philadelphia, Pa.
 AMERICAN SOCIETY OF MECHANICAL ENGINEERS.—Calvin W. Rice, 20 W. Thirty-ninth street, New York. Annual meeting, December 7-10, 1915, New York.
 ASSOCIATION OF RAILWAY ELECTRICAL ENGINEERS.—Joseph A. Andreucetti, C. & N. W., Room 411, C. & N. W. Sta., Chicago. Annual meeting, October, 1915.
 CAR FOREMEN'S ASSOCIATION OF CHICAGO.—Aaron Kline, 841 North Fiftieth Court, Chicago; 2d Monday in month, except July and August, Lytton building, Chicago.
 CHIEF INTERCHANGE CAR INSPECTORS' AND CAR FOREMEN'S ASSOCIATION.—S. Skidmore, 946 Richmond street, Cincinnati, Ohio. Annual meeting, September 14-16, 1915, Richmond, Va.
 INTERNATIONAL RAILWAY FUEL ASSOCIATION.—C. G. Hall, 922 McCormick building, Chicago.
 INTERNATIONAL RAILWAY GENERAL FOREMEN'S ASSOCIATION.—William Hall, 1126 W. Broadway, Winona, Minn.
 INTERNATIONAL RAILROAD MASTER BLACKSMITHS' ASSOCIATION.—A. L. Woodworth, Lima, Ohio. Convention, August 17, 1915, Philadelphia, Pa.
 MASTER BOILER MAKERS' ASSOCIATION.—Harry D. Vought, 95 Liberty street, New York.
 MASTER CAR BUILDERS' ASSOCIATION.—J. W. Taylor, Karpen building, Chicago.
 MASTER CAR AND LOCOMOTIVE PAINTERS' ASSOC. OF U. S. AND CANADA.—A. P. Dane, B. & M., Reading, Mass. Convention, September 14-17, 1915, Detroit, Mich.
 NIAGARA FRONTIER CAR MEN'S ASSOCIATION.—E. Frankenberger, 623 Brisbane building, Buffalo, N. Y. Meetings monthly.
 RAILWAY STOREKEEPERS' ASSOCIATION.—J. P. Murphy, Box C, Collinwood, Ohio.
 TRAVELING ENGINEERS' ASSOCIATION.—W. O. Thompson, N. Y. C. R. R., East Buffalo, N. Y. Convention, September 7-10, 1915, Hotel Sherman, Chicago, Ill.

PERSONALS

It is our desire to make these columns cover as completely as possible all the changes that take place in the mechanical departments of the railways of this country, and we shall greatly appreciate any assistance that our readers may give us in helping to bring this about.

GENERAL

WILLIAM H. ELSNER has been appointed chief draftsman, motive power department, of the Great Northern Railway, at St. Paul, Minn., succeeding N. R. Ross, promoted.

N. C. HOOPER has been appointed car foreman of the Grand Trunk Pacific at Smithers, B. C., succeeding A. McKinnon.

W. B. McNIECE has been appointed car foreman of the Grand Trunk Pacific at Prince Rupert, B. C., succeeding W. Thompson.

A. MCKINNON has been appointed car foreman of the Grand Trunk Pacific at McBride, B. C., succeeding W. B. McNiece.

J. F. MOFFATT has not been appointed district locomotive foreman of the Grand Trunk Pacific, as was reported in these columns last month. The circular announcing the appointment has since been cancelled.

L. G. ROBLIN has been appointed general master mechanic of the National Transcontinental Railway and the Lake Superior branch of the Grand Trunk Pacific, with headquarters at Cochrane, Ont.

J. S. SHEAFE, master mechanic, Staten Island Lines of the Baltimore & Ohio at Clifton, Staten Island, N. Y., has been granted leave of absence for one year.

CAR DEPARTMENT

P. ALQUIST, whose appointment as general superintendent of the car department of the Missouri, Kansas & Texas at Dennison, Tex., has already been announced in these columns, was

born in Stockholm, Sweden, in 1874, and came to this country in 1885, settling in Memphis, Tenn. He started his railroad career as car repairer for the Illinois Central at Memphis in the early part of 1895, working for the same road as car interchange inspector, repair track foreman and general foreman of the car department of the Memphis, Mississippi & Fulton divisions until 1910, when he left to go with the Cincinnati, Hamilton, & Dayton as general foreman of the car department at Lima, Ohio.



P. Alquist

He left that road after about eighteen months' service to go to the Pere Marquette as general car foreman at Grand Rapids, Mich., and was subsequently general inspector and chief inspector of the car department of that road. In 1913, Mr. Alquist was appointed superintendent of the car department of the Missouri, Kansas & Texas, at Sedalia, Mo., which position he held at the time of his recent appointment as general superintendent of the car department of that road.

SHOP AND ENGINE HOUSE

G. FEETHAM has been appointed acting roundhouse foreman of the Intercolonial at Truro, N. S., succeeding W. Davidson.

A. H. KENDALL has been appointed assistant works manager of the Angus locomotive shops of the Canadian Pacific, at Montreal, Que.

L. C. ORD has been appointed assistant works manager of the Angus car shops of the Canadian Pacific at Montreal, Canada.

W. WELLS has been appointed general foreman of the Canadian Pacific at North Bay, Ont., succeeding A. H. Kendall, promoted.

C. WHITE has been appointed roundhouse foreman of the National Transcontinental Railway at Edmundston, N. B.

PURCHASING AND STOREKEEPING

R. A. LUNSFORD has been appointed storekeeper of the Kansas City, Mexico & Orient of Texas, with headquarters at Angelo, Tex., succeeding T. A. Pratt.

COMMISSION APPOINTMENTS

H. A. HERNDON, chief draftsman of the Fort Worth & Denver City, at Childress, Tex., has been appointed junior mechanical engineer, division of valuation, of the Interstate Commerce Commission, with headquarters at Kansas City, Mo.

NEW SHOPS

ATCHISON, TOPEKA & SANTA FE.—This company is constructing a seven-stall brick engine house at Prescott, Ariz. The work has been begun.

ILLINOIS CENTRAL.—This company will build wooden car repair shop buildings at Nonconnah, Tenn. The estimated cost of these new repair shops is about \$150,000.

MAINE CENTRAL.—The contracts have been awarded and the work on the construction of additional buildings for the Maine Central shops at Waterville, Maine. The estimated cost is \$60,000.

LEHIGH VALLEY.—This company will at once build a fireproof roundhouse, with stalls for fifty locomotives at Sayre, Pa. Contract for the building, which is to be of hollow tile and cement construction, has been given to Westinghouse, Church, Kerr & Company, New York. The total cost of the improvements will be \$400,000, including a new turntable and accessories.

OREGON-WASHINGTON RAILROAD & NAVIGATION COMPANY.—This company will build a 12-stall roundhouse, a 40-ft. by 60-ft. storehouse, a 30-ft. by 40-ft. powerhouse, and a 50-ft. by 60-ft. machine shop at The Dalles, Ore. The powerhouse, machine shop and roundhouse will be brick buildings with mill interior, and the storehouse will be a corrugated, galvanized steel building on wood frame.

CHICAGO, BURLINGTON & QUINCY.—This company is rebuilding its blacksmith shop at Galesburg, Ill., which was recently destroyed by fire. The work is being done by company forces.

BALTIMORE & OHIO CHICAGO TERMINAL.—This company is building new engine and passenger terminal facilities at Fourteenth and Robey streets, Chicago, which will include a 33-stall roundhouse, a 300-car coach yard, a 2-story building 600 ft. long for coach yard supplies, a power plant, oil house, coaling station, sand house and office building. Contracts for the construction of these buildings have been awarded to James Stewart & Co., Chicago.

SUPPLY TRADE NOTES

The Sauvage-Ward Brake Company, Inc., New York, has recently changed its name to the Smith-Ward Brake Company, Inc.

Andrew Allen, Sr., the founder of the firm of A. Allen & Son, New York, died July 6.

George F. Alderdice has resigned as assistant general manager of sales of the Republic Iron & Steel Company, to become assistant to the president of the Brier Hill Steel Company.

J. F. McNamara has been appointed general manager of the Bayonne Steel Casting Company, Bayonne, N. J., succeeding W. E. Oakley.

The Scullin-Gallagher Iron & Steel Company, St. Louis, Mo., by a vote of its stockholders has changed its name to the Scullin Steel Company.

Thomas R. Cook, formerly assistant engineer of motive power of the Pennsylvania Lines West, has been appointed chief engineer of the Willard Storage Battery Company, Cleveland, Ohio.

Flint & Chester, Inc., New York, dealers in railway, mill and contractors' supplies, have been appointed New York sales agents for the jacks made by A. O. Norton, Inc., Boston, Mass.

H. A. F. Campbell has been appointed European representative of the Baldwin Locomotive Works, with headquarters in Paris. Mr. Campbell has been in the service of the company since 1900.

F. N. Hibbits, until July 1 superintendent of motive power of the Lehigh Valley at South Bethlehem, Pa., has been appointed assistant general superintendent of the Baldwin Locomotive Works, effective July 1.

The American Steel Export Company was incorporated in Delaware on June 29, with a capital of \$200,000, to promote the sale abroad of products of the Cambria Steel Company. H. Gossen has been placed in charge of the New York office.

Paul B. Oatman, formerly manager of the Ideal Die & Tool Company, Beaver Falls, Pa., has been appointed manager of the small tools department of the Modern Tool Company, Erie, Pa.

Louis F. Beckert, a salesman in the railway equipment division of the railway and lighting department of the Westinghouse Electric & Manufacturing Company, died suddenly of typhoid fever at his home in Pittsburgh on July 7.

L. S. Love, formerly head of the L. S. Love Machinery Company, has become associated with the Sherritt & Stoer Company, Inc., Philadelphia, Pa., dealers in machine tools and railway and machine shop equipment.

W. D. Waugh, district representative in St. Louis, Mo., of the Kalamazoo Railway Supply Company, Kalamazoo, Mich., has been appointed district representative in charge of the St. Louis office of the Detroit Graphite Company, succeeding Benjamin Randolph, resigned.

The National Hose Coupling Company, which has recently been incorporated, with Mortimer J. Silverberg as president, will manufacture a coupling which is applicable to various railway uses. The works of this company are at Kankakee, Ill., and its general offices are in the Peoples Gas building, Chicago.

R. A. Paterson, H. M. Buck and John B. Given, formerly the United Railway Specialties Company, 30 Church street, New York, have been appointed representatives of Mudge & Company, Chicago, in the New England, Eastern and Southern States. The representation of Mudge products covers the Mudge motor cars, Mudge-Peerless ventilators and the Mudge-Slator locomotive front end.

The Continental Piston Ring Company, Memphis, Tenn., has been incorporated with a paid in capital of \$100,000. It will manufacture piston rings for locomotives, engines, automobiles and pumps of various kinds. The officers are B. H. Mason, president; W. P. McCadden, vice-president; R. E. Brown, secretary and treasurer, and C. R. Bryant, chief engineer.

The United States Light & Heat Corporation, Niagara Falls, N. Y., has been incorporated with a capital of \$7,000,000 to manufacture machinery, batteries and apparatus for the production of electric light and heat. It is a reorganization of the United States Light & Heat Company, and will take over and continue the operation of that company's plant at Niagara Falls. G. M. Walker, A. L. Fowle and A. S. Jones, 60 Broadway, New York, are the directors.

W. Spencer Robertson, assistant to Leigh Best, vice-president of the American Locomotive Company, has been appointed secretary of the company, succeeding C. B. Denny, formerly treasurer and secretary, who has resigned. Mr. Robertson has been in the service of the American Locomotive Company since May 1, 1908. He was born in Brooklyn, January 10, 1885, and from November, 1900, until 1908 he was associated with the law office of Simpson, Thacher & Bartlett, New York.

Thomas E. Carliss, manager of the works of the Buffalo Brake Beam Company at Buffalo, N. Y., and Hamilton, Ont., died suddenly in Buffalo on July 9. Mr. Carliss had been in the brake beam business for about 30 years. He was at one time associated with the Central Brake Beam Company, at Detroit, for many years, afterwards becoming associated with the Monarch Brake Beam Company, when that company was started by Detroit capital. He had been in the service of the Buffalo Brake Beam Company for about six years.

The Locomotive Stoker Company, Schenectady, N. Y., has purchased the coal pusher business and taken exclusive licenses under all of the patents covering mechanical coal pushers for locomotive tenders owned by Ryan, Galloway & Co., Chicago, which, with the patents already controlled, will enable the Locomotive Stoker Company to add a complete line of mechanical coal pushers for all classes of locomotive tenders to its rapidly growing stoker business. Edward Ryan, of Ryan, Galloway & Co., has entered the employ of the Locomotive Stoker Company as mechanical expert.

The Columbus Bolt Works Company, Columbus, Ohio, has been incorporated with a capital stock of \$660,000 to take over the business of the Columbus Bolt Works. J. R. Poste, formerly secretary and general manager of the Columbus Bolt Works, has been elected president, treasurer and general manager of the company; J. H. Poste, vice-president; T. A. Fleming, assistant treasurer, and H. A. Mason, secretary. The incorporators include J. R. Poste, J. H. Poste, W. F. Burdell, Beale Poste and F. H. Barrett. Julius Blum & Co., 510 West Twenty-fourth street, New York, have been appointed the eastern sales agents of the company.

John Havron, president of the Rogers Locomotive Works, Paterson, N. J., from 1901 to 1908, and more recently an officer

of the Walker & Bennett Car Seat Company, died in Jersey City on Saturday, July 25, at the age of 56, from cancer of the stomach. Mr. Havron started his career as a clerk in the employ of the old Rogers Locomotive & Machine Works in Paterson, N. J., in 1881. He gradually worked his way up to the position of secretary of the company, but left in 1893 to go to Chicago as the western representative of the Latrobe Steel Company, Latrobe, Pa. In 1901, when the Halloran and Smith syndicate bought the Rogers Locomotive Works, he returned to that company as its president and held that position until October 1, 1908, leaving at that time to go with the Latrobe Steel & Coupler Company, with office at Chicago.

Roy C. McKenna, of the McKenna Brothers Brass Company, Pittsburgh, Pa., has been elected president of the Vanadium-Alloys Steel Company, also of Pittsburgh. He succeeds E. T. Edwards, who has resigned to accept the presidency of the Latrobe Electric Steel Company, Latrobe, Pa., but who will remain a member of the board of directors of the Vanadium-Alloys Steel Company. Mr. McKenna brings to his new position the experience gained in the years he has been the head of the mechanical department of the McKenna Brothers Brass Company. He graduated from the University of Pittsburgh in 1903 in electrical and



R. C. McKenna

mechanical engineering. Mr. McKenna's family has had considerable experience in the high-speed steel trade, having been identified with it ever since the year 1902.

Charles B. McElhany, general manager of sales of the Cambria Steel Company, has been elected also a vice-president of that company. Mr. McElhany has been in the steel business for about 20 years, and in the service of the Cambria Steel Company for four years. His early years in the steel industry were spent in the employ of the Braddock Wire Company, the American Steel & Wire Company, the Union Steel Company and the Pittsburgh Steel Company. About nine years ago he entered the service of the Colorado Fuel & Iron Company, becoming assistant general manager of sales of that company. He then became assistant manager of sales of the Cambria Steel Company, in charge



C. B. McElhany

of the wire division. He was later appointed assistant general manager of sales, and on March 1 succeeded J. L. Replogle as general manager of sales.

The Roberts & Schaefer Company, Chicago, has issued the following announcement: "We desire to announce that we have voluntarily released our control over the Holmen patents as relates to locomotive coaling plant equipment, and have canceled our agreement with Mr. Holmen. Two years ago we secured control of an improved design of elevating machinery which, while retaining all of the advantages of our previous equipment under the Holmen patents, entirely eliminates the bucket latches, closing springs, and trippers required by those patents. This change greatly improves the service and reliability. The results obtained after two years' operation of many representative plants, warrants us in making this form our standard, which we will hereafter employ in all of our locomotive coaling stations."

Henry S. Hawley, president of the Railroad Supply Company of Chicago, died on July 22, at his summer home in Saundertown, R. I. He was born on August 12, 1851, at Bridgeport, Conn. From 1874 to 1883 he was actively engaged in bridge contracting and in promoting and constructing railroads, during which time he was identified with the Grand Trunk from Valparaiso, Ind., to Thornton, Ill., and also purchased at Master's sale the Chicago & Southern, now owned by the Grand Trunk. In 1883 he was the promoter of the Chicago & Wisconsin, which was leased to and completed by the Chicago, Wisconsin & Minnesota, and was president of the latter road during its construction from Chicago to Schlesingerville, Wis. This is now a part of the Minneapolis, St. Paul & Sault Ste. Marie. He was general agent and purchased a part of the right of way of the Chicago Great Western, and on its completion was appointed general agent in charge of traffic and leases. From 1890 to October, 1893, he was general agent in charge of traffic of the Chicago & Northern Pacific, and later was general agent and treasurer for the receivers of the same road. On July 1, 1897, he was made general agent and treasurer of the reorganized company, which was called the Chicago Terminal Transfer Company, and on February 1, 1899, he was appointed traffic manager, treasurer and assistant secretary of the same road. On June 1, 1902, he was elected president of the Railroad Supply Company.



H. S. Hawley

DUTY OF A PUMP.—There are different definitions for what is termed the duty of a pump, each giving a different estimate or value. The duty is sometimes defined as the weight in pounds of water raised through a vertical height of one foot for each 100 lb. of coal burned; or, more simply, the theoretical work (ft.-lb.) performed per hundredweight of coal burned under the boiler. It is observed that this definition is faulty, because it combines furnace and boiler efficiencies with that of the pump itself, besides estimating only the theoretical work performed, thus eliminating friction, which is often a most important factor. The true definition of duty in pumping is the actual work performed in a given time (ft.-lb.), per million B. t. u. delivered to the pump in the same time. Or, less frequently, the duty is estimated in foot-pounds of work per thousand pounds of dry saturated steam consumed.—*Coal Age*.

CATALOGS

COLD STORAGE SYSTEM.—Bulletin No. 221 recently issued by the Link-Belt Company, Chicago, is a four-page leaflet descriptive of the Link-Belt patented circular storage system. The leaflet describes the system in detail, names its several advantages and contains illustrations of typical installations.

WOOD BLOCK FLOORS.—The Ayer & Lord Tie Company, Chicago, has recently issued a booklet on that company's interior creosoted wood block floors. The booklet discusses the several advantages of this type of flooring material and contains several illustrations of wood block floors laid in different kinds of shops.

GAS ENGINES.—Bulletin No. 34-X issued by the Chicago Pneumatic Tool Company, Chicago, is devoted to the Class A-G "Giant" gas and gasoline engines made by that company. Bulletin No. 34-U contains instructions for installing and operating "Chicago Pneumatic" Class N-SO fuel oil driven compressors.

AIR COMPRESSORS.—Form No. 3,031 recently issued by the Ingersoll-Rand Company, New York, is devoted to the Ingersoll-Rogler Class FR-1 steam driven single stage straight line air compressors sold by that company. The company has also recently issued Form No. 4,034, relative to the Leyner-Ingersoll water drill.

TOOLS FOR CUTTING SCREW THREADS.—This is the title of a catalog recently issued by the J. M. Carpenter Tap & Die Company, Pawtucket, R. I. The booklet, which is quite similar to the usual tap and die catalog, contains illustrations of the taps, dies, die-stocks, etc., made by the company, as well as tables of sizes and list prices.

SLOTING MACHINES.—Catalog No. 49, recently issued by the Newton Machine Tool Works, Inc., Philadelphia, Pa., contains illustrations and specifications of the company's complete line of standard and special slotting machines and a number of illustrations of different designs of milling, boring, drilling and cold saw cutting off machines.

CAR HEATING APPARATUS.—The Gold Car Heating & Lighting Company, New York, has recently issued circulars relative to that company's No. 804S positive lock coupler, its pressure regulator No. 1,014 and its up-to-date vapor system. The latter also shows how Gold's thermostatic control may be used in connection with the vapor system.

ELECTRICAL TESTING SERVICE.—The Electrical Testing Laboratories, Inc., New York, have recently issued an attractive loose-leaf booklet describing the equipment, organization and work of these laboratories. The service offered by the Laboratories includes the testing of instruments, electrical materials and machinery and tests of electric lamps.

FABRIKOID.—In a publication entitled "The Orange Book," the Du Pont Fabrikoid Company, Wilmington, Del., presents a number of exhibits which are extracts from proceedings or articles dealing with upholstery, all of which are used to show the superiority of Fabrikoid to the poorer grades of split leather for use in furniture upholstery, automobiles, etc.

SUPERHEATERS.—The Locomotive Superheater Company, 30 Church street, New York, has issued the fourth edition of its pamphlet entitled "The Use of Highly Superheated Steam in Locomotive Practice." This is devoted to a description of the Schmidt superheater, including data concerning its operation. A number of superheater accessories are also described.

GEARED LOCOMOTIVES.—The Heisler Locomotive Works, Erie, Pa., has recently issued catalogue No. 115, describing in detail

the construction of the Heisler Geared Locomotives and classes of service for which they are suited. The various parts of the locomotive are described and information is included concerning the methods of laying out rough spur tracks.

LEATHER GOODS.—The Du Pont Fabrikoid Co., Wilmington, Del., has just issued an attractive bulletin on Fabrikoid, which is made with a face of cotton cloth coated with a tough flexible material and embossed by steel plates or rolls to produce the appearance of any desired natural leather grain. The cover of this booklet is printed in colors and shows five different colors and grains of Fabrikoid. The booklet is well printed and illustrated.

AUTOGENOUS WELDING.—In the Panama-Pacific International Exposition number of Autogenous Welding, the Davis-Bournonville Company, Jersey City, N. J., presents a number of articles descriptive of various large pipe line installations where the welding of the joints has been performed by its apparatus. The leading article deals with the installation of gas mains on the Exposition grounds at San Francisco, which were laid with welded joints.

GEARS, PINIONS AND TROLLEYS.—The R. D. Nuttall Company, Pittsburgh, Pa., has recently issued catalog No. 12 relative to gears, pinions and trolleys for mine and industrial locomotives, and catalog No. 13 devoted to like equipment for electric railways. Each booklet contains illustrations and specifications of the apparatus described, there being included extensive tables giving the sizes and list price of the gears and pinions which may be obtained.

HEAT INSULATION.—A four-page folder recently issued by the Armstrong Cork & Insulation Company, Pittsburgh, Pa., is devoted to its high pressure covering for use on high pressure and superheated steam lines, boilers and other heated surfaces. This material is made up of a special form of silica of a minute cellular construction, mixed with asbestos. Owing to the cellular nature of the silicious material, it is said to be an exceptionally good heat insulator.

PASSENGER CAR COUPLERS.—The McConway & Torley Company, Pittsburgh, Pa., has recently issued an eight-page booklet descriptive of the Pitt Passenger Coupler. In addition to an illustration of the coupler, the booklet also contains three drawings showing the coupler's great flexibility of curvature. Fig. 1 shows the limits of such flexible movement; Fig. 2, the extreme positions to which the couplers will adjust themselves in passing over a curve and tangent, and Fig. 3, the relative positions on a reverse curve.

FLEXIBLE JOINTS.—Barco Flexible Joints is the title on the cover of a loose-leaf booklet recently issued by the Barco Brass & Joint Company, Chicago. In this booklet are contained catalog No. 10 relating to blow-off terminal coach heating and wash-out nozzle connections; catalog No. 20 relating to roundhouse blower connections and specifications and the Barco automatic smokebox blower fitting; catalog No. 30 entitled "Barco Flexible Joints, Catalogue and Descriptive Bulletin," and catalog No. 40 relating to engine tender connections for steam, air and oil and car connections for steam and air.

VERTICAL GAS ENGINE.—The National Transit Company, Oil City, Pa., has recently issued bulletin No. 401, in which is illustrated and briefly described a vertical four-cycle, air cooled gas engine. A unique feature in the design of this engine is the use of the exhaust to induce the circulation of air through the cooling flanges on the cylinder. Bulletins Nos. 104 and 105, also recently issued, are devoted to a line of the Duplex direct acting type steam pumps, the former outside center packed and the latter of the packed piston type. These pumps are designed for service from 200 lb. to 1,000 lb. pressure per sq. in.

Railway Age Gazette

MECHANICAL EDITION

INCLUDING THE
AMERICAN ENGINEER

PUBLISHED ON THE FIRST THURSDAY OF EVERY MONTH BY THE
SIMMONS-BOARDMAN PUBLISHING COMPANY
WOOLWORTH BUILDING, NEW YORK, N. Y.

CHICAGO: Transportation Bldg. CLEVELAND: Citizens' Bldg.
LONDON: Queen Anne's Chambers, Westminster.

EDWARD A. SIMMONS, *President* L. B. SHERMAN, *Vice-President*
HENRY LEE, *Secretary-Treasurer*

The address of the company is the address of the officers

ROY V. WRIGHT, *Editor*

R. E. THAYER, *Associate Editor* A. C. LOUDON, *Associate Editor*
C. B. PECK, *Associate Editor*

Subscriptions, including the eight daily editions of the *Railway Age Gazette* published in June in connection with the annual conventions of the Master Car Builders' and American Railway Master Mechanics' Associations, payable in advance and postage free:

United States, Canada and Mexico..... \$2.00 a year
Foreign Countries (excepting daily editions). 3.00
Single Copy 20 cents

Entered at the Post Office at New York, N. Y., as mail matter of the second class.

WE GUARANTEE, that of this issue 7,000 copies were printed; that of these 7,000 copies 5,524 were mailed to regular paid subscribers, 154 were provided for counter and news companies' sales, 262 were mailed to advertisers, exchanges and correspondents, and 720 were provided for new subscriptions, samples, copies lost in the mail and office use; that the total copies printed this year to date were 52,000, an average of 5,667 copies a month.

The RAILWAY AGE GAZETTE, MECHANICAL EDITION, and all other Simmons-Boardman publications are members of the Audit Bureau of Circulations.

VOLUME 89

SEPTEMBER, 1915

NUMBER 9

CONTENTS

EDITORIALS:

The Apprentice Letters.....	439
The Car Inspector Competition.....	439
Boiler Inspection Competition.....	439
Piston Valve Ring Competition.....	439
Locomotive Mileage Account.....	440
Freight Car Inspection.....	440
Of Interest to Car Men.....	440
Improved Locomotive Design.....	440
Quality and Shop Output.....	441
New Books.....	441

COMMUNICATIONS:

Engine Failures.....	442
Saving Coal.....	442

GENERAL:

Reciprocating and Revolving Parts.....	443
Locomotive Headlight Requirements.....	451
Diagram for Determining Percentage of Maximum Tractive Effort.....	453
Road Tests for Determining Front End Conditions.....	454
Model Locomotive Built by Apprentices.....	456

CAR DEPARTMENT:

Inspection and Repairs of Freight Cars by Piecework.....	457
Freight Car Stenciling Outfit.....	458
Design of Steel Passenger Equipment.....	459
Towel Receptacle for Sleeping Cars.....	461
Norfolk & Western Humidity-Controlled Dry Kiln.....	462
The Ventilation of Sleeping Cars.....	464
Disinfectant Arrangement for Passenger Cars.....	466
Car Electric Lighting Systems.....	467
Stenciling Gage for Freight Cars.....	468
Uniformity in Car Inspection.....	468

SHOP PRACTICE:

Reinforced Asbestos Gaskets for Air Pump Cylinder Heads.....	469
An Electric Process for Safe-Ending Tubes.....	469
Testing Devices for Air Brakes.....	470
Turning Commutators in the Power House.....	470
Master Blacksmiths' Convention.....	471
The Electric Furnace for Reheating, Heat Treating and Annealing.....	481

NEW DEVICES:

Berdan Brake Rigging.....	483
Kingan-Ripken Valve Gear Device.....	483
Air Brake Hose.....	484
Emergency Coupler Head.....	484
Roof Construction for Passenger Cars.....	485
Cotter and Keyseat Drill.....	486
Adjustable Hub Plate.....	486
High Compression Oil Engine.....	487
Ball Joint Connection for Main Reservoirs.....	487
Electric Hand Lantern.....	488
Journal Jack.....	488
Metal Band Saw.....	488
Double Action Force Feed Cylinder Lubricator.....	489
Constant Current Electric Welder.....	490
Water Glass Guard.....	490

NEWS DEPARTMENT:

Notes.....	491
Meetings and Conventions.....	491
Personals.....	492
Supply Trade Notes.....	493
Catalogs.....	494

The Apprentice Letters

When we went to press with this issue, the closing date (September 1) for the competitive letters on "How Can I Help the Apprentice Boys?" had not arrived. A large number of letters had been received, however. The best one of the letters entered in the competition will be selected by the judges in the contest and will be printed in the October number, the writer meanwhile being paid the reward of \$10. Such other letters as may be suitable for publication, in whole or in part, will be printed in the same or succeeding issues and will be paid for at our usual rates. The experiment has worked out so well that we have decided to conduct a series of similar competitions in the months to come, as will be noted by announcements made elsewhere in the editorial columns. Our hearty appreciation is due to those who have helped to make the contest a success. We shall be glad to receive comments or additional suggestions on the facts which are presented in the letters when they are published.

The Car Inspector Competition

The prize competition on "How Should Car Inspectors Be Trained and Developed and What Are Their Qualifications?" which was announced on page 384 of our August issue, will close on October 1, 1915. Don't fail to study the announcement and to mail your contribution in time to reach our offices in the Woolworth building, New York, on or before that date. The best article on the basis of the practical suggestions which are made will be awarded a prize of \$35. Other articles accepted for publication will be paid for at our usual rates. The car inspector's position is a most difficult one to fill. Familiarity with the interchange and loading rules requires a great amount of study and much practical experience. Many of the rules are exceedingly complex, requiring more than average intelligence correctly to interpret and apply them. The selection, training and development of men who can do this work satisfactorily has given car department officers much concern. The object of the competition is to bring out as many practical and helpful suggestions as possible.

Boiler Inspection Competition

The federal requirements for inspecting and testing locomotive boilers have made it necessary for each railroad to develop a corps of boiler inspectors to see that the requirements are fully understood and fulfilled. The position is one of great responsibility and requires practical men of much intelligence and experience. Are these men given proper facilities for performing their work? Have they plenty of room, with convenient files for sorting and keeping the necessary records, data, etc.? Is their method of working carefully planned to secure the greatest efficiency? What suggestions can you make which will help them to perform their work more effectively? To develop facts and practical suggestions along some one of these or other phases of the locomotive boiler inspector's work we will give a prize of \$35 for the best article which is received at our office in the Woolworth building, New York, on or before November 1, 1915. As in all of our competitions, the judges will base their decision on the practical value of the facts and data which are brought out and the logical way in which they are presented, rather than on the composition or grammatical arrangement of the article.

Piston Valve Ring Competition

During the discussion of the methods of machining piston-valve rings at the recent convention of the General Foremen's Association, much interest was displayed by the members generally as to the various methods used by the different roads. Four types of valve rings are used, the rectangular, the L, the T and the Z-shaped rings. Each road has good reasons for using some one of these types. The proper machining of the rings is also an important matter with

respect to the efficiency with which the rings do their work, economy in operation and the effect on the life of the rings. In order to obtain definite information along these lines a prize of \$10 will be given to the person sending the best letter on the subject to our offices in the Woolworth building, New York, on or before October 1. It is desired to obtain, as far as possible, data as to the service obtained from the rings, the reason for using a certain specific type, the cost and time of making the ring, as well as details concerning the actual operations of machining. Not all of these phases of the question need necessarily be considered in any one letter. They are given rather in the way of suggestions in order to bring out the best practices used under different conditions on different roads. The judges will make the award on the basis of the practical value of the information presented, but will not attempt to decide which practice is best according to the arguments which are advanced by the competitors. Articles which are not awarded the prize, but which are accepted for publication, will be paid for at our usual rates.

Locomotive Mileage Account

For every locomotive mile used by the transportation department an available locomotive mile must be created by the mechanical department. This is the basis on which a road should operate if it is desired to keep the transportation department well supplied with power. The available locomotive mileage is an account from which the transportation department draws as it moves the trains. Every locomotive as it comes from the shops is good for a certain number of miles; say, for instance, 50,000. If the transportation department consumes 500,000 locomotive miles in one month then ten of these locomotives should have been turned out of the shops during that month to maintain the proper mileage account balance. When new locomotives are purchased there are just so many locomotive miles to be added to the account and, conversely, when the locomotives are removed from service the mileage account becomes reduced. Those engines that are in service should be inspected each month with a view to determining the amount of mileage they still have available, the mileage they have already made and their present condition being considered. By doing this the head of the mechanical department knows very nearly what available mileage he has and if retrenchments are desired, just how far he can cut down his forces and still provide the transportation department with the mileage it will require. On a large road this system should apply as a unit to each division, the passenger and freight locomotives being considered separately. If still greater refinement is desired the locomotive tractive power miles could be ascertained.

Freight Car Inspection

With another bumper grain crop in sight the car department is called upon to prepare the equipment for its transportation. In doing this too much care cannot be exercised in providing grain-tight cars. Defective equipment causes a large percentage of the loss and damage claims. For the last five years there has been an average of 69 cars a day entering Chicago with grain leakage defects. For the six months ending June 30, 1914, the railways reported to the American Railway Association a loss of \$600,000 for grain due to defective equipment.

By careful repairs and rigid inspection the car department can do its part in reducing these excessive claims. The cars to be loaded with grain should be made grain-leakage proof and rain tight. The front, top and rear of the car doors should be so coopered that no moisture can penetrate into the car. The sheathing should be carefully inspected. About 65 to 70 per cent of the grain leakage defects are chargeable to the sheathing; the flooring is responsible for the rest and it, too, should not be neglected. A leaking roof on a grain car is worse than no roof at all, for without a roof the grain would not be shipped

in the car. The system of testing roofs as described on page 399 of our August issue has given exceedingly good results. There are many other details that must be carefully watched if the grain leakage proof and rain-tight cars are to carry the bumper crop successfully; a small defect will eat up the profits derived from the carrying of this grain at a very rapid rate.

Of Interest to Car Men

When we proposed a few years ago regularly to devote a certain proportion of the pages of this journal to the interests of the car department some of our good friends laughed at us and said that the scheme "wouldn't work." True, they said, there is lots of good material in that department which ought to be dug up and published, but the car men will not take a sufficient amount of interest in it to make the venture really worth while; moreover, you will have a strenuous time in filling up the allotted number of pages each month.

It may be interesting to know just what has been the result of this innovation. Since January, 1913, when the scheme was first tried, the car department has been well represented in each issue. For instance, in 1913 there were 146 pages and in 1914, 142 pages of strictly car department material in the Car Department Section. This does not include the representation of that department in the editorial comments, letters to the editor, shop practice articles and new devices—a representation which was not by any means small; nor does it include the 128 pages in the four *Daily Railway Age Gazettes* issued during the Master Car Builders' Convention in 1913 and the 103 pages in the *Daily* for the M. C. B. Convention in 1914, these issues being furnished to all *Mechanical Edition* subscribers. Equally as good a record has been made thus far during the current year. So much for material.

How about the interest shown by car department officers and foremen? Our success, as indicated by a study of the subscription list, has been equally as great as in the securing of material. Even at that, however, we are not satisfied. Two things more we want to do. First, we would like to still further enlarge the car department section, and, secondly, we plan to improve its quality, or possibly we might better say to give more attention to certain classes of material. To be perfectly frank, it is comparatively easy to secure good articles on car design and construction and concerning certain of the broader car department problems. It is difficult, however, to secure certain classes of articles which go thoroughly into the practical details and methods followed by that department. Don't misunderstand this statement. There is a lot of such material available but not up to the standard or grade that we wish to present to our readers, who represent the most active and ambitious men in the department. We are going to demonstrate, however, that such material can be obtained and regularly presented. One way in which this will be done will be by a series of prize competitions, the first one of which was announced in the August issue and is commented on elsewhere in these columns. We bespeak your earnest and hearty co-operation in this movement. From such results as are already apparent we know it will prove a big success.

Improved Locomotive Design

"As the size and power of the locomotive is increased, the moving parts per unit of work to be done need not be increased in weight. On the contrary, their weight per unit of work done may be reduced. Light parts do not necessarily mean weak parts, but may mean stronger parts." These sentences sum up the thought which H. A. F. Campbell wished to develop in his series of articles on "Reciprocating and Revolving Parts," which has appeared in the *Mechanical Edition* during the past six months. The first three of these articles published in the March, April and May issues concerned improvements which have been made in lightening the

revolving and reciprocating parts on American locomotives, both by improved design and the use of alloy and heat treated carbon steels. The last two installments, one in the August issue and the other in another part of this issue, concern similar developments on British locomotives. Mr. Campbell is to be congratulated on the thorough and complete way in which he has gone into this subject, which promises to prove one of the important developments in locomotive design that will be brought about in the next few years.

Never has a difficult and complicated technical development in the locomotive field been discussed in a more thorough manner. That this has been appreciated is indicated by the fact that the Committee on Counterbalancing for the Master Mechanics' Association, which made one of the most effective reports at the June convention, made use of considerable data taken from Mr. Campbell's articles, and publicly expressed its appreciation. The committee, near the end of its report, concluded that "the secret of proper counterbalancing for any class of locomotive in any service is to reduce the weight of the reciprocating parts as far as possible. * * * Special designs of piston heads, crossheads, hollow piston rods and the use of high-grade materials, including heat-treated carbon and alloy steel, aluminum, etc., make it possible to construct very light parts, the expense of which will be many times justified by the consequent saving in repairs to equipment and track, as well as the saving due to the increase in tractive power of the locomotives."

Quality and Shop Output Great stress is generally laid on the importance of a high shop output, the common basis of measurement being the number of locomotives a month which can be repaired in a given shop. The ability of a foreman to increase the output of a shop is very commonly used as an indication of his value as a mechanical department officer. No doubt this is a reasonably good method of arriving at an estimate of a man's ability; we do not question this, but we do question the advisability of using it as the only basis for arriving at such an estimate. Quantity is desirable and even essential in shop output. Economy demands that locomotives spend as large a proportion of the time as possible in earning money, which means that they must spend as little time as possible undergoing repairs. But there is more to the repair question than the heavy repairs made in the back shop. Most locomotive repair work is done in engine houses and it is at this point that the effect of laying too much stress on general repair shop output or quantity with a neglect of the quality of the work done makes itself most directly felt.

We do not wish to be understood as advocating a reduction in shop output, but we do believe that there are many shops in this country which are rated entirely on the number of locomotives turned out per month in determining the output, when the railway company would be money in pocket if the output were reduced as far as numbers are concerned and steps taken to materially improve the work turned out. There are railways that are doing heavy repair work in engine houses—work that should by rights be done in the general shop—simply because the general shops are required to do so many general repairs per month and the quality of the work is given but secondary consideration. We have known general foremen and shop superintendents to purposely let work get by in a partially completed condition or hurry it through at the expense of the workmanship in order to keep up the record of shop output. We do not believe there are many such men, but there is a tendency in a great many cases to overlook little things or to shirk inspection if the doing of these things thoroughly is likely to delay an engine in getting out of the shop. But if the little things are not done in the general shop they will have to be done in the engine house and they may develop into larger things that will compel the return of the engine to the general

repair shop long before it has made its full mileage. These are matters to which sufficient consideration is not given in the wild rush toward increased shop output on the number of locomotives basis, but they have their bearing on not only the cost of maintaining locomotives but on the cost of conducting transportation. This is a matter which demands serious attention from higher railway officers as well as shop superintendents and foremen. The maximum possible output of any shop is desirable provided it can be accompanied by the highest quality of workmanship. Such a combination should be the end toward which railway mechanical men work rather than quantity in shop output alone. Quantity without quality will invariably result in increased maintenance charges and decreased mileage between shoppings; quantity and quality combined will tend toward economy in locomotive maintenance and train movement.

NEW BOOKS

Practical Mechanics and Allied Subjects. By Joseph W. L. Hale, S.B., E.E., associate professor of engineering, Pennsylvania State College, 228 pages, 4½ in. by 7 in. Illustrated. Bound in cloth. Published by the McGraw-Hill Book Company, Inc., 239 West 39th Street, New York. Price, \$1.00 net.

The author of this book has for several years been detailed as supervisor of apprentice schools on the Pennsylvania lines east of Pittsburgh and Erie, and his purpose in preparing this book was to meet the demand of apprentice schools for a text dealing directly with the problems arising in the mechanical trades. Very little has been published which is especially adapted to the needs of trade schools generally and more particularly to the railroad apprentice school, and with the present tendency toward the growth of such institutions the need of books such as the present volume is rapidly increasing.

The material in this volume is presented in 20 chapters. A glance at the contents gives the impression of a rather heterogeneous collection of subjects, some of which the pure mechanics and others purely shop problems with very little relation to the science involved. Each chapter, however, deals with one subject and covers it completely, so that the order of presentation may be readily altered. The foregoing points will be understood by noting the titles of the first eight chapters: Chapter I, Forces; Chapter II, Gravitation, Center of Gravity; Chapter III, Density and Specific Gravity; Chapter IV, Screw Threads; Chapter V, Calculation of Levers; Chapter VI, Pulleys (Block and Tackle); Chapter VII, The Inclined Plane and Wedge, the Screw Jack; Chapter VIII, Gears, Lathe Gearing. Other subjects of a practical nature which are treated are belts and pulleys, cutting speeds of machine tools, calculation of belting, etc. These are interspersed with chapters on motion, volume and pressure of gases, work and power, heat, logarithms, the measurement of right triangles and the measurement of oblique triangles. The two concluding chapters of the book deal with electricity and the strength of materials respectively, each being a brief elementary treatise on its respective subject. The arrangement of the material, while apparently of a haphazard nature, is undoubtedly good for the purpose intended as the chapters dealing with the abstract subjects are interspersed with those dealing with problems of immediate application.

Proceedings of the Air Brake Association. Compiled and published by F. N. Nellis, secretary, Boston, Mass. 296 pages, 6 in. by 8½ in. Bound in leather.

This contains the report of the twenty-second annual convention of the Air-Brake Association, which was held in Chicago last May. It includes committee reports on the "Accumulation of Moisture and Its Elimination From Trains and Yard Testing Plants;" "Operation of the Pneumatic Signal;" "One Hundred Per Cent Operative Brakes in Freight Service;" "Hand Brakes for Heavy Passenger Cars," and "Revision of Recommended Practice."

COMMUNICATIONS

ENGINE FAILURES

NEW YORK.

TO THE EDITOR:

I have been greatly interested in the editorial in your August issue on "Prevention of Engine Failures," in which you say that the engine house is often unjustly charged with the responsibility for such failures. I agree with you, but will go still further. In many cases the responsibility is absolutely up to the supervising officers, although they do not realize it and would be seriously offended if so charged.

If a part is wrongly designed and constructed, and causes frequent failures, those in charge should have a check on it and see that improvements are made in the design and that the construction is changed as the engines go through the back shop for general repairs. The same is true of inefficient methods of operation and of man failures. The cost of engine failures is so great, direct and indirect, that each case should be thoroughly investigated and the blame properly placed. Then, construction methods should be devised to prevent similar failures in the future. This does not mean that a simple investigation on the part of the local officials will suffice. Each failure should be considered by a board of important mechanical and operating officers—and it will not be a bad idea to have the storekeeper sit in with them on some roads. In this way the responsibility cannot be shifted back and forth from one department to another. The time of such officers is, of course, valuable, and some provision must be made to have the reports completed and containing all the facts and evidence before they are presented to the board or committee.

After all, is it not true that the greater proportion of engine failures are "man failures"—an evidence of lack of proper supervision?

ENGINEER.

SAVING COAL

ATLANTIC CITY, N. J.

TO THE EDITOR:

As an enginehouse foreman at the outlying end of a division, I have had some interesting experiences in connection with coal economy during the past year. To begin with, the superintendent of the division made some inquiries as to the necessity of cleaning the fire on the engine of a freight train having a short turn-around run. What he said convinced me that I would be backed up in any point that was well taken, and I acted accordingly.

This division is about 60 miles long and we have trains coming to us from other divisions, making one-way runs of 72 and 142 miles, respectively. There is a summer and winter schedule and at the time referred to we only had one short turn-around passenger run on the winter schedule besides the freight run mentioned. The no fire cleaning rule was applied to this passenger engine. The engineman and fireman immediately said they would not be responsible for any steam failures on the return trip. They did not have any and during the entire winter the fire of this engine was not cleaned at this point. When the summer schedule went into effect the following year we did not clean the fires on any engines having two hours or less for a turn around. This resulted in a saving of 520 fires cleaned for the summer season alone. The lowest estimate that can be placed on the coal used when a fire is cleaned is about 250 lb. more than when the fire is not cleaned. This shows a saving of 80,000 lb. for the season of about three months.

There was another matter I had noticed, but had never taken any action on: this was the taking of coal. Practically every engine arriving here was taking coal and this in spite

of the fact that out of a tender having a 25,000-lb. coal capacity only about 8,000 lb. or 9,000 lb. had been used. The hostlers were therefore instructed not to coal engines arriving on trains on the 60 and 72-mile runs unless they were personally ordered to do so. The enginemen and firemen when they found out about this order started in to put up every argument in their power; they would not be responsible for low steam; they would not be responsible if they ran out of coal; I exceeded my authority in issuing such orders. But the principal point and the one on which they felt that they were in the right was that the coal was not within reach of the fireman as required by the firemen's regulations. The firemen's regulations do not state or define when the coal is not within reach of the fireman and if we take two engines each starting out with a tank full of coal, one on a 60-mile run and one on the 142-mile run, it is obvious that the coal on the engine making the 60-mile run must still be within reach of the fireman at the end of the trip, or it would be necessary to put another man on the engine making the 142-mile run to shovel the coal down for the fireman. Acting on this line of reasoning, the firemen were told to go as far as they liked in the matter. We are still following this practice after it has been in effect a year. The first full month that this order was in effect was May, 1914, and with 87 less engines handled for that month as compared with the month of April, there was a saving of 2,050,000 lb. of coal loaded on tenders of locomotives. For the following four months which represents the period when our heaviest business is done there was a difference of 10,966,300 lb. less coal loaded in 1914 than during the same four months of 1913, the number of engines handled being practically the same.

It must be admitted that this does not represent that much less coal burned—it may not show any saving in that way—but it does show a big saving in freight due to hauling the coal at least 60 miles further away from the mine, and then hauling the empty cars back again. The company had started on a coal-saving campaign and shortly after issuing the order about loading coal on tenders a notice was posted that the firemen would not be permitted to start working on the fires of locomotives until one hour of train leaving time. The engines were supposed to leave the enginehouse 30 minutes before train leaving time, and this gave them 30 minutes to prepare the fire. As only bituminous coal was being used and as during my enginehouse experience we have frequently had to build new fires and have the engines ready to leave with trains in less time than that. I felt sure that this could be done without causing any trouble.

The firemen, however, protested vigorously, and so did some of the enginemen, that the fire could not be prepared properly for the kind of service they were in. It had been the practice for the fireman to start to push down the fire about two hours before train time and then shovel coal and blow the fire so he could start out with a heavy coked fire. During this time both safety valves would blow off most of the time, the black smoke would roll out and they were really making a dirty fire to start with. However, the firemen are an inconsistent bunch; they pay a committee to have them relieved of cleaning off the seat box that they sit on and the cab windows that they look through, but then they want to fight because they were not permitted to shovel coal one hour longer than was necessary. This order, however, was lived up to and caused no trouble, and if the company wanted the men to go back to their old way of working no doubt some of them would now want to put in a time card for overtime.

The saving in coal effected by this is rather difficult to estimate, but should amount to at least 100 lb. per engine. The same economies can probably be effected at other points similarly situated.

CHARLES MAIER.

POWER REQUIRED TO RAISE WATER.—The power required to raise water may be approximated by multiplying the gallons per minute by the elevation in feet and dividing by 3300.—*Power.*

RECIPROCATING AND REVOLVING PARTS

Discussion of British Practice, Including the London, Brighton and South Coast and the Midland

BY H. A. F. CAMPBELL*

This is the fifth and concluding article in this series; the first three considered American practice (March issue, page 109; April, page 163, and May, page 215) and the fourth (August issue, page 390) discussed British practice.

The London, Brighton & South Coast outside-cylinder Baltic

wheels. The main and side rods are shown in Figs. 38 and 40. The bearing pressures on the pins are shown in Table XIV. The stresses at the different sections of the rods have been marked on the drawings.

The main crank pin is shown in Fig. 39. This style of pin

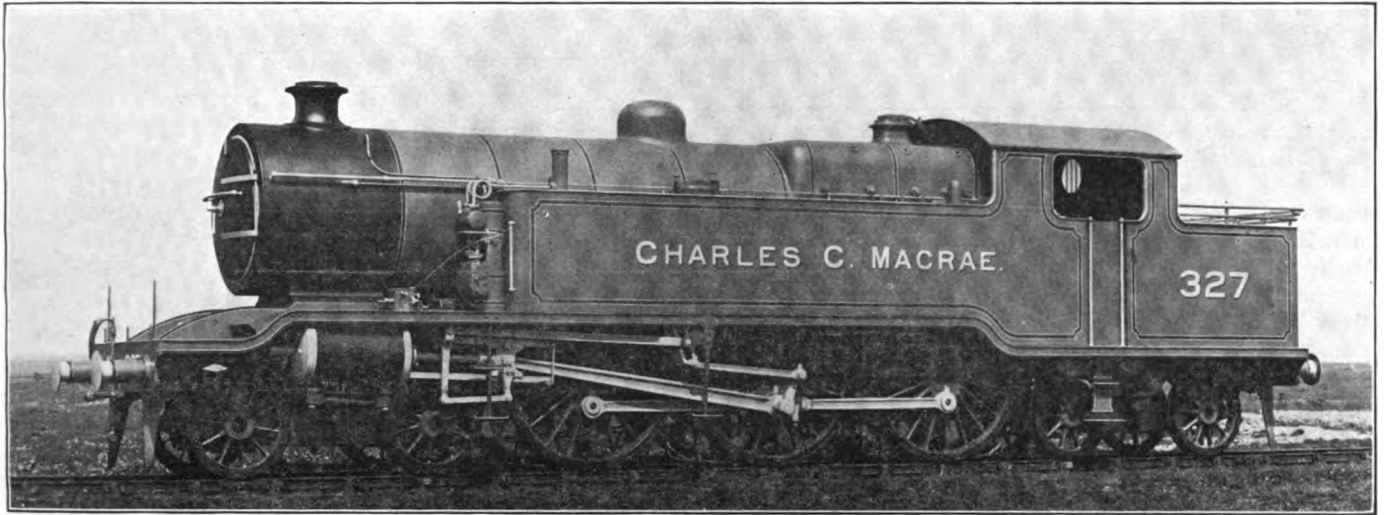

Fig. 37—London, Brighton & South Coast 4-6-4 Tank Locomotive

(4-6-4) type tank locomotive is shown in Fig. 37. This engine has 22 in. by 28 in. cylinders; a boiler pressure of 170 lb. per sq. in. (superheated steam), and 81 in. diameter driving

wheels. It is often used in England. By making the main rod and side rod pin eccentric, the throw of the side rod is reduced from a 28 in. stroke to a 26½ in. stroke. This may seem like a

*Baldwin Locomotive Works, Philadelphia, Pa.

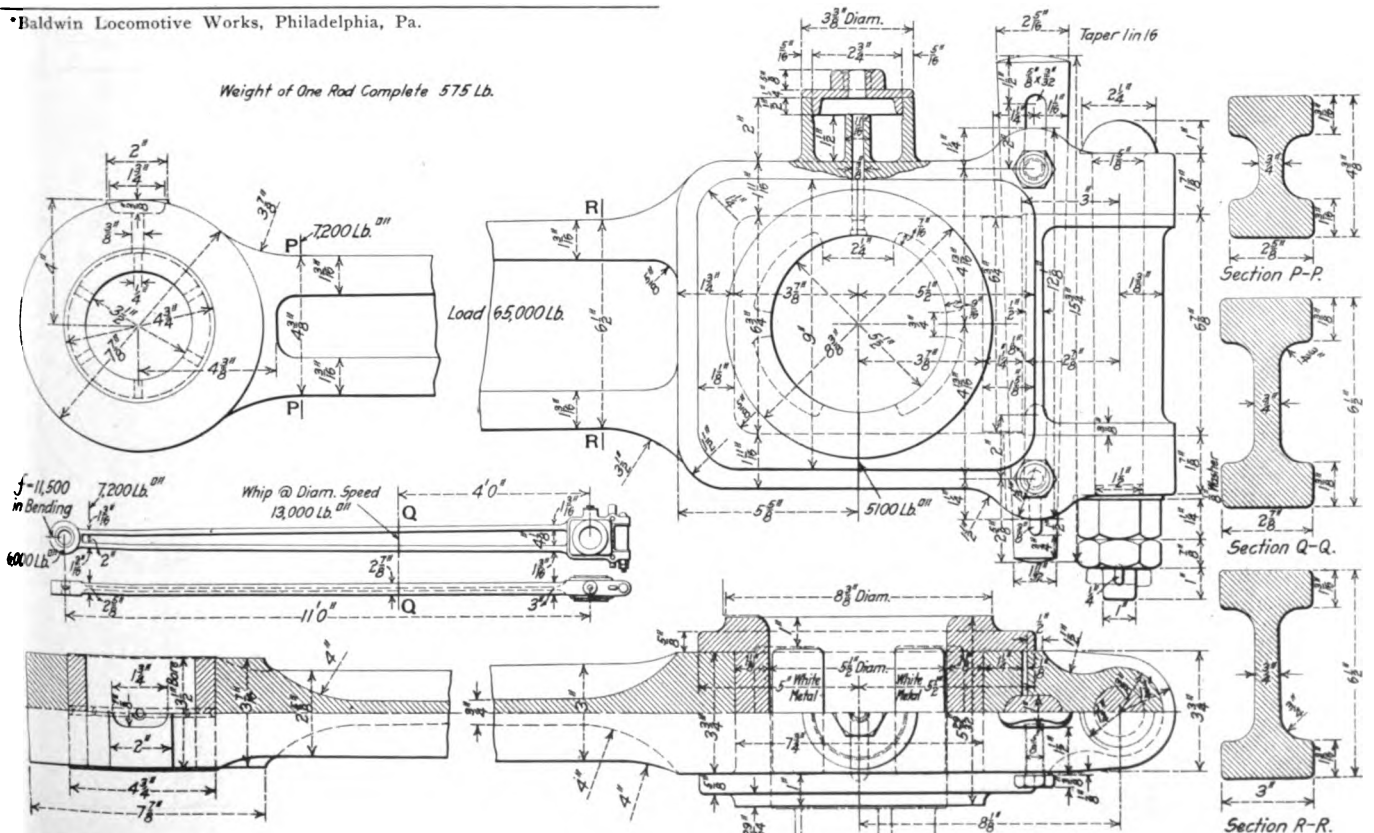

Fig. 38—Main Rod of London, Brighton & South Coast 4-6-4 Type Locomotive

TABLE XIV—BEARING PRESSURE ON PINS OF LONDON, BRIGHTON & SOUTH COAST 4-6-4 TYPE LOCOMOTIVE

Location of pin	Size	Load, lb.	Bearing pressure, lb. per sq. in.
Crosshead	3½ in. x 3½ in.	65,000	5,300
Main	5½ in. x 6 in.	65,000	1,970
Front	7 in. x 3½ in.	21,700	1,220
Main (side rod)	7 in. x 3½ in.	43,400	1,770
Back	5 in. x 3½ in.	21,700	1,220
Knuckle	2¾ in. x 1¾ in.	45,500	9,480

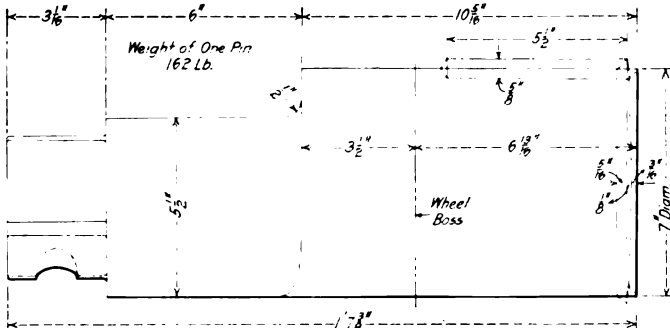

Fig. 39—Main Crank Pin for London, Brighton & South Coast 4-6-4 Type Locomotive

small detail, but it is attention to just such details that helps to reduce unnecessary weight. The fiber stress on this pin in bending is low—only 9,600 lb. per sq. in. The piston-rod and crosshead are shown in Figs. 42 and 43, and the stresses are given in Table XV.

TABLE XV—STRESSES IN CROSSHEAD AND PISTON ROD OF LONDON, BRIGHTON & SOUTH COAST 4-6-4 TYPE LOCOMOTIVE

Section and kind of stress.	Amount of stress, lb. per sq. in.
Shear on key	10,600
Tension in rod through keyway	10,700
Tension in neck of crosshead through keyway	3,850
Crushing of key on the rod	20,100
Crushing of key on the crosshead	27,500
Bearing pressure, pin on crosshead	5,600
Compression in main shank of rod	7,830

The head is made of cast steel, is of the flat plate type and is shown in Fig. 41. The valve motion parts on European engines are usually very light, and the parts of this particular

engine are a good example of their practice. It is not intended to analyze them in detail, but the design is clearly shown in Figs. 44, 45, 46, 48, 49, 51 and 52.

The Somerset & Dorset Joint Railway (Midland Railway) outside-cylinder 2-8-0 type locomotive is shown in Fig. 47. This engine has cylinders 21 in. by 28 in.; a boiler pressure

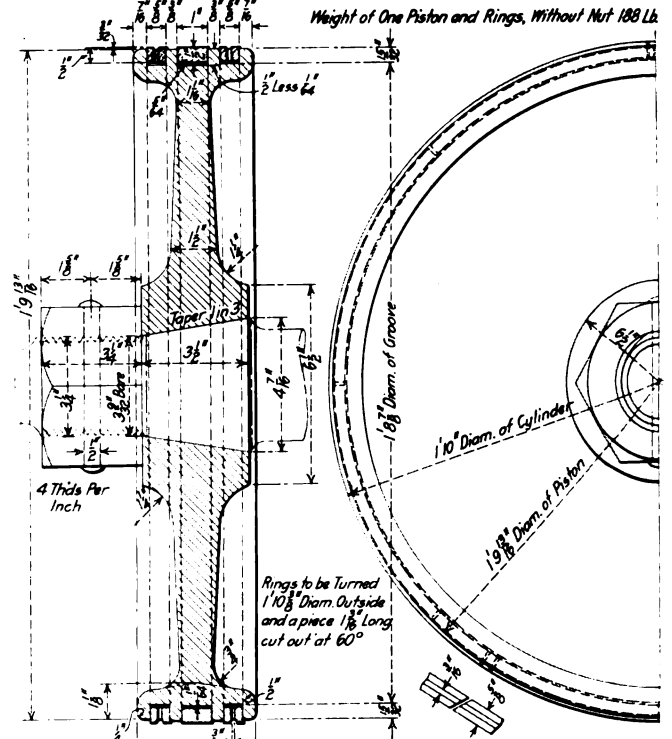

Fig. 41—Cast Steel Piston Head of London, Brighton & South Coast 4-6-4 Type Locomotive

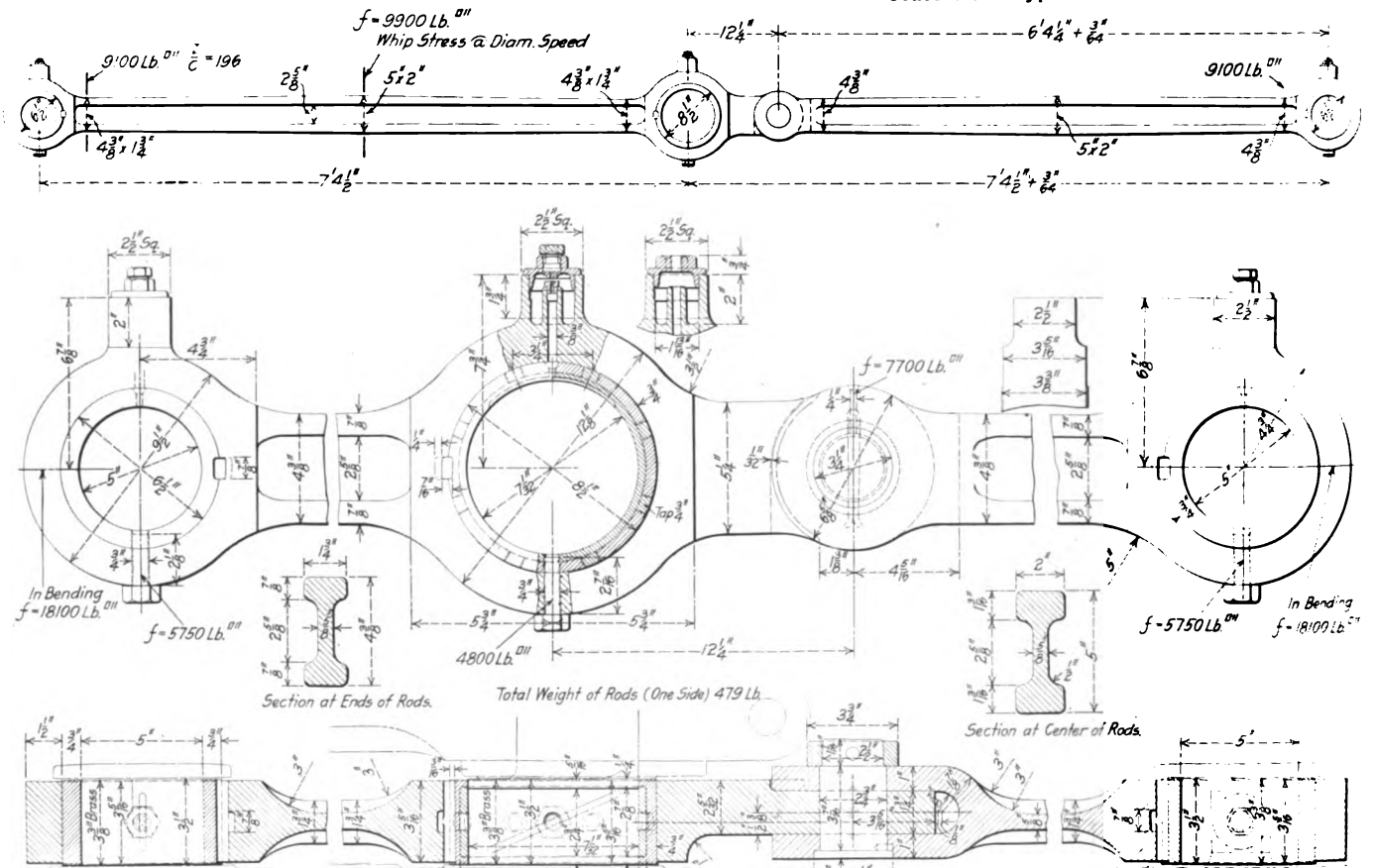

Fig. 40—Side Rods of London, Brighton & South Coast 4-6-4 Type Locomotive

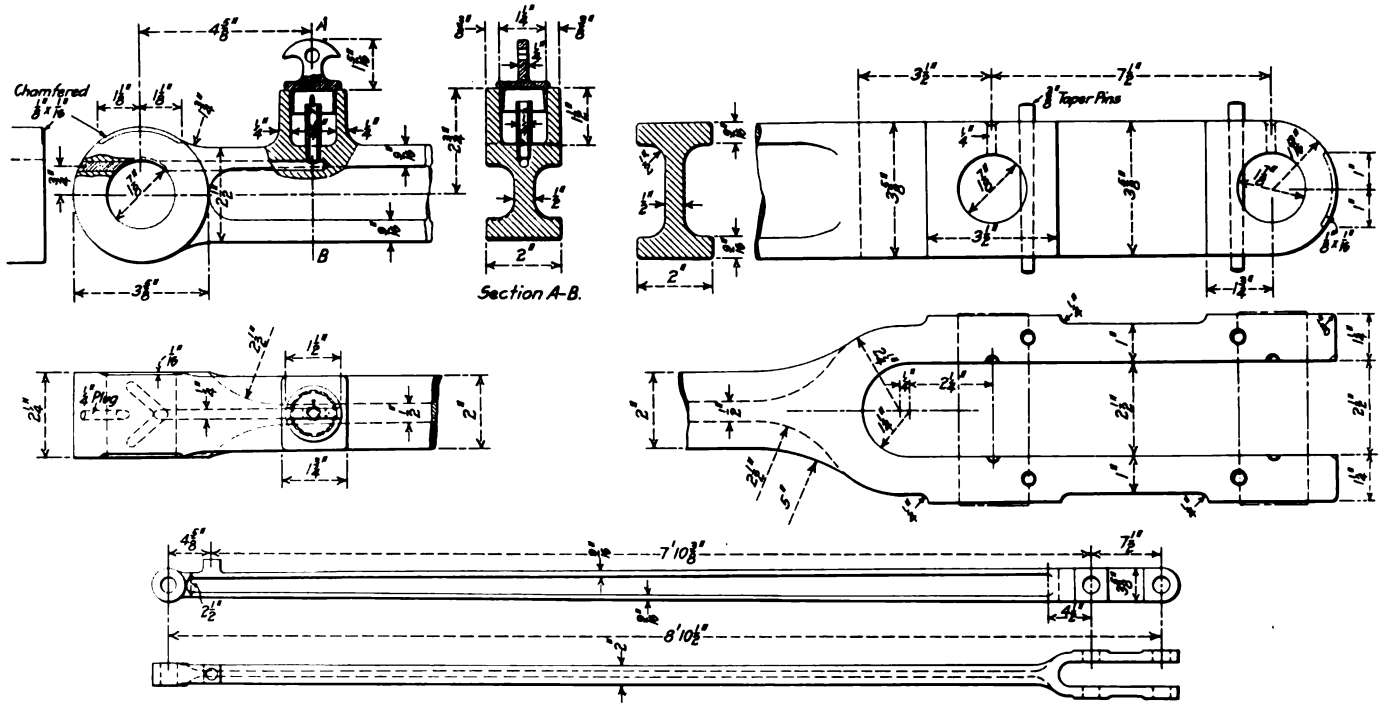

Fig. 44—Radius Rod of London, Brighton & South Coast 4-6-4 Type Locomotive

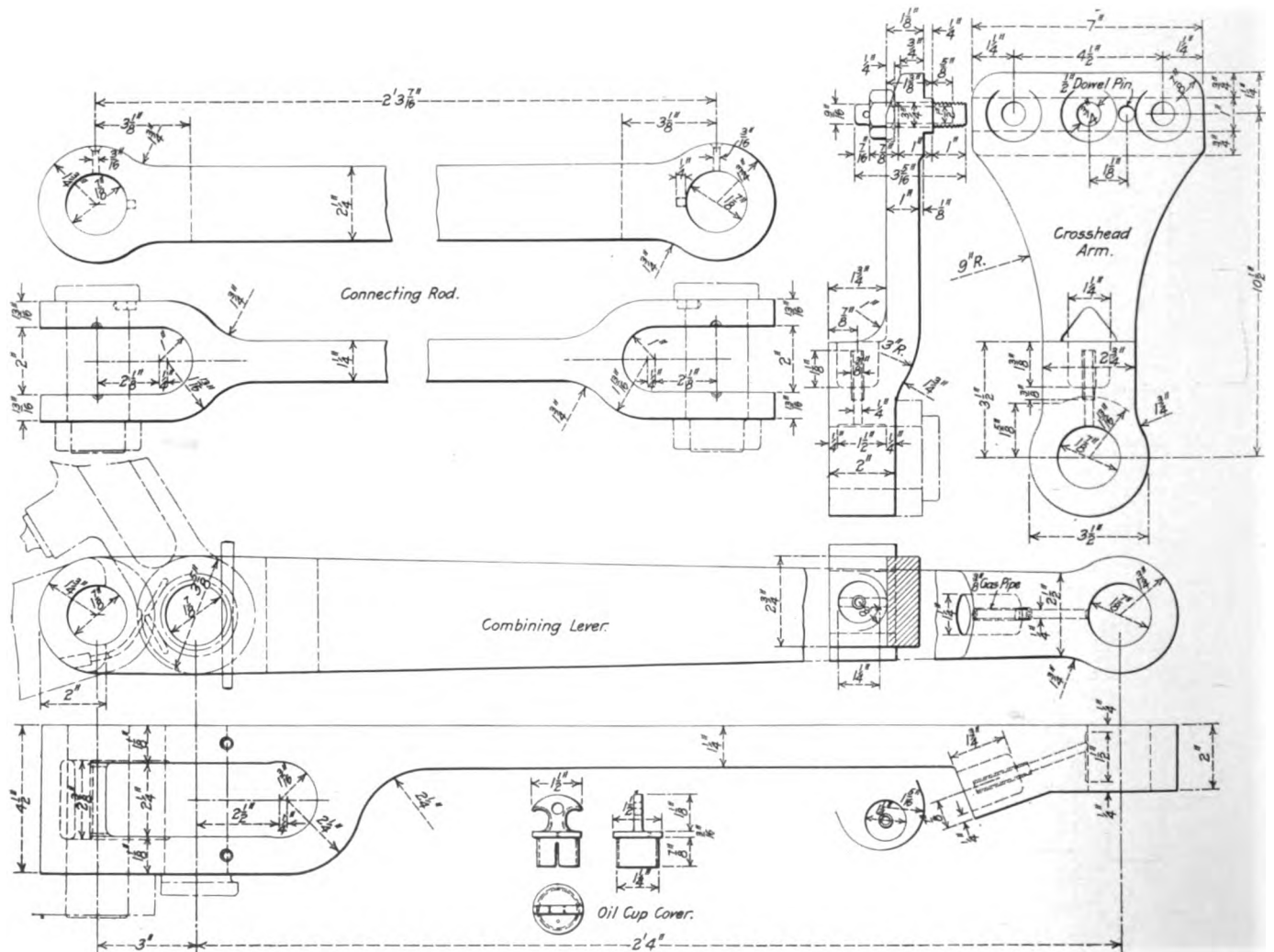

Fig. 45—Union Link, Crosshead Arm, and Combination Lever for 4-6-4 Type Locomotive

of 190 lb. per sq. in. (superheated steam), and driving wheels 55½ in. in diameter.

The main rod and side rods are shown in Figs. 50, 53 and 54, and the bearing pressures on the pins are given in Table XVI. The stresses at the different sections have been noted on the

TABLE XVI—BEARING PRESSURE ON PINS OF SOMERSET & DORSET JOINT RAILWAY (MIDLAND) 2-8-0 TYPE LOCOMOTIVE

Location of pin	Size	Load, lb.	Bearing pressure, lb. per sq. in.
Crosshead	3¼ in. x 3¼ in.	65,800	6,200
Main	6 in. x 5¼ in.	65,800	2,090
Front	4 in. x 3¾ in.	16,450	1,060
Intermediate	5 in. x 3¾ in.	16,450	845
Main (side)	6½ in. x 4¾ in.	49,350	1,600
Back	4 in. x 3¾ in.	16,450	1,060
Knuckle	2½ in. x 2 in.	39,500	7,900

drawings. Open-hearth acid Siemens-Martin steel with an ultimate strength of 72,000 to 83,000 lb. per sq. in. is used for these rods.

The main rod complete weighs only 500 lb. A big saving in weight has been obtained by using the solid end type of main stub. The proportions of the I-section have been care-

fully worked out and are an example of the type of I-section that the Baldwin Locomotive Works has used for some years:

$$\frac{1}{p} = \frac{8,800 \text{ lb.}}{181 \text{ lb. per sq. in.}}$$

must be considered high.

The crosshead and piston-rod are shown in Figs. 55 and 56 and the stresses are given in Table XVII. The piston rod is made of Siemens-Martin acid open-hearth steel and has an ultimate strength varying from 94,000 lb. per sq. in. with an elongation of 15 per cent in 3 in. to 107,000 lb. per sq. in. with an elongation of 12 per cent in 3 in.

The crosshead, Fig. 55, is made of cast steel of an ultimate

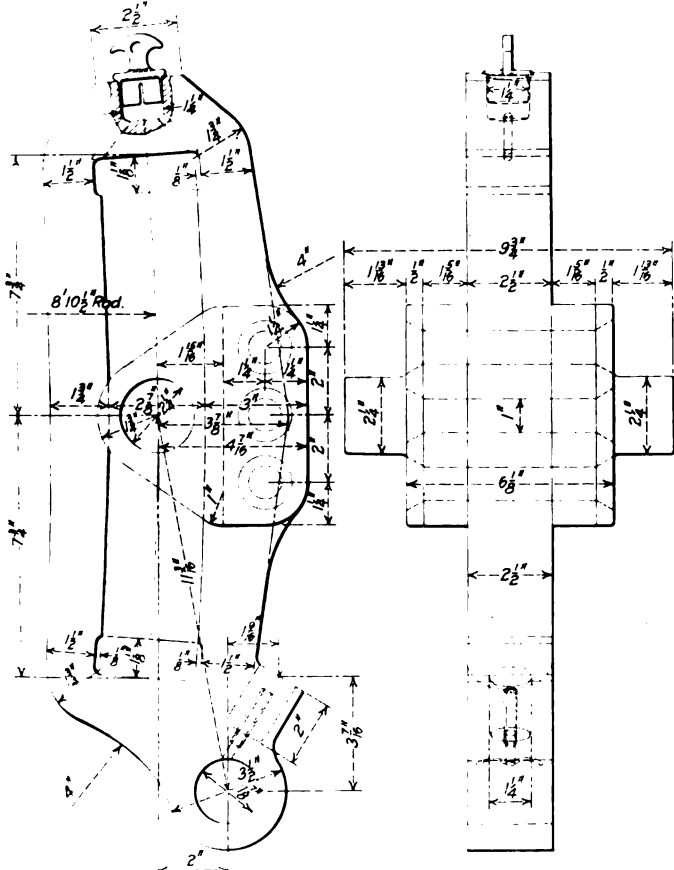

Fig. 46—Valve Motion Link for London, Brighton & South Coast 4-6-4 Type Locomotive

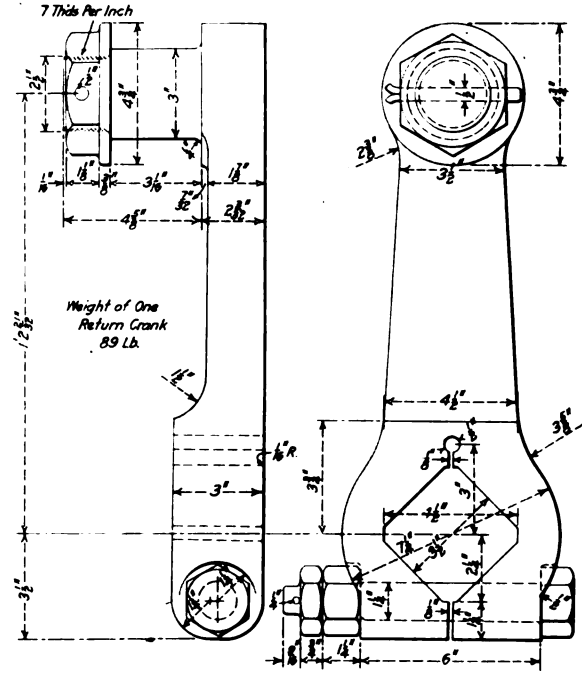

Fig. 48—Valve Motion Return Crank for 4-6-4 Type Locomotive

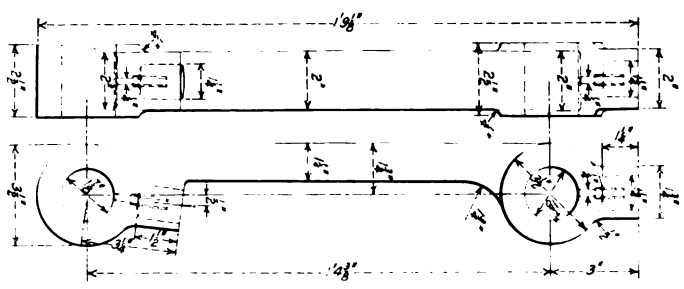

Fig. 49—Radius Rod Lifter for 4-6-4 Type Locomotive

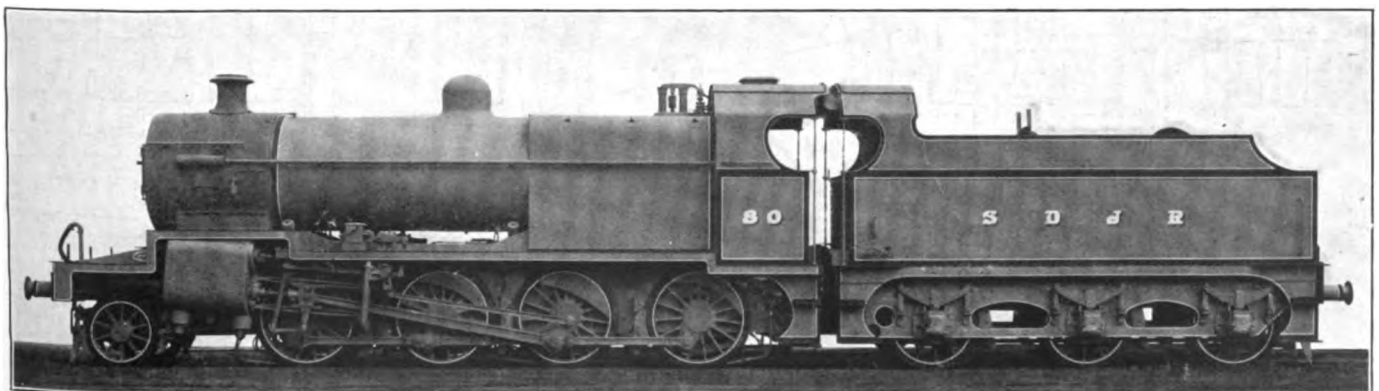

Fig. 47—Somerset & Dorset Joint Railway (Midland) 2-8-0 Type Locomotive

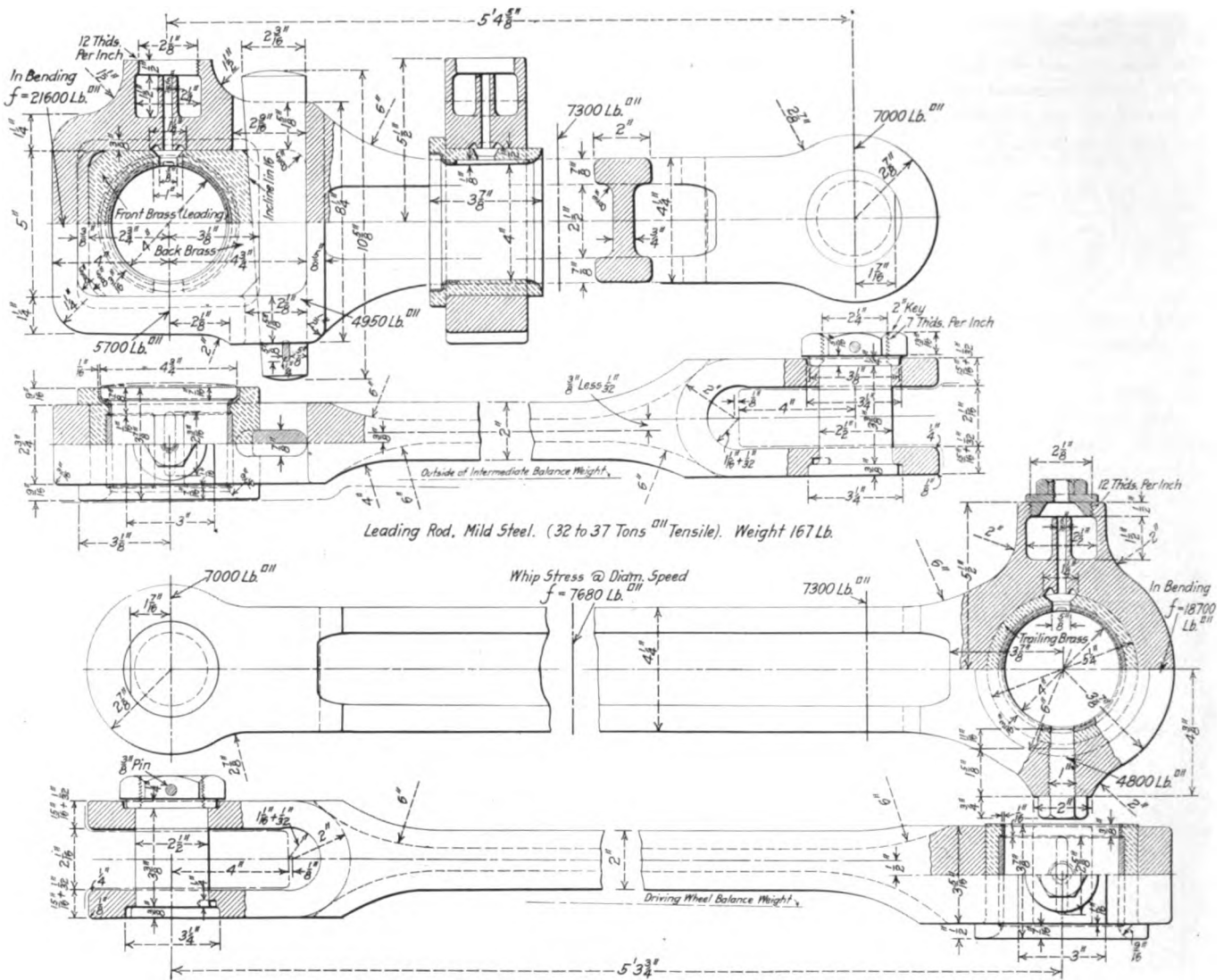

Fig. 50—Front and Rear Side Rods for 2-8-0 Type Locomotive

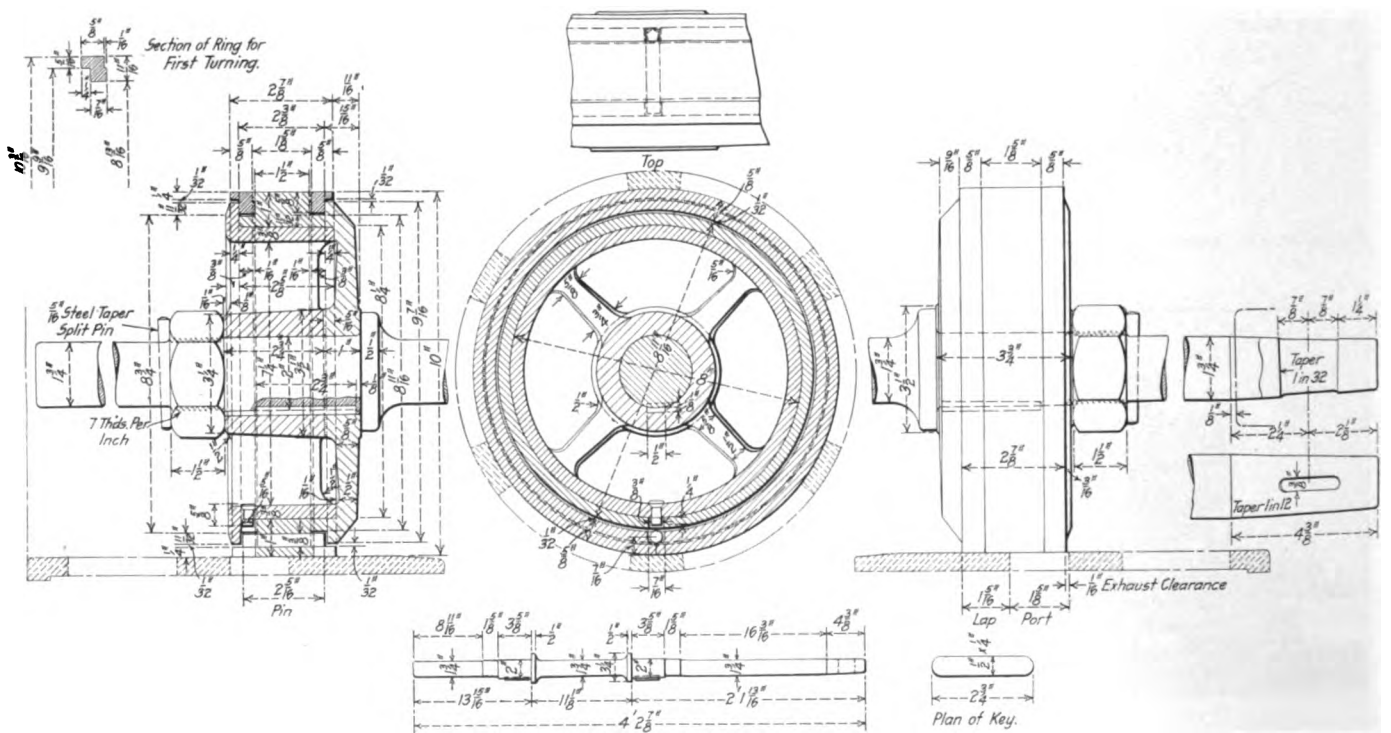

Fig. 51—Piston Valve and Valve Rod for 4-6-4 Type Locomotive

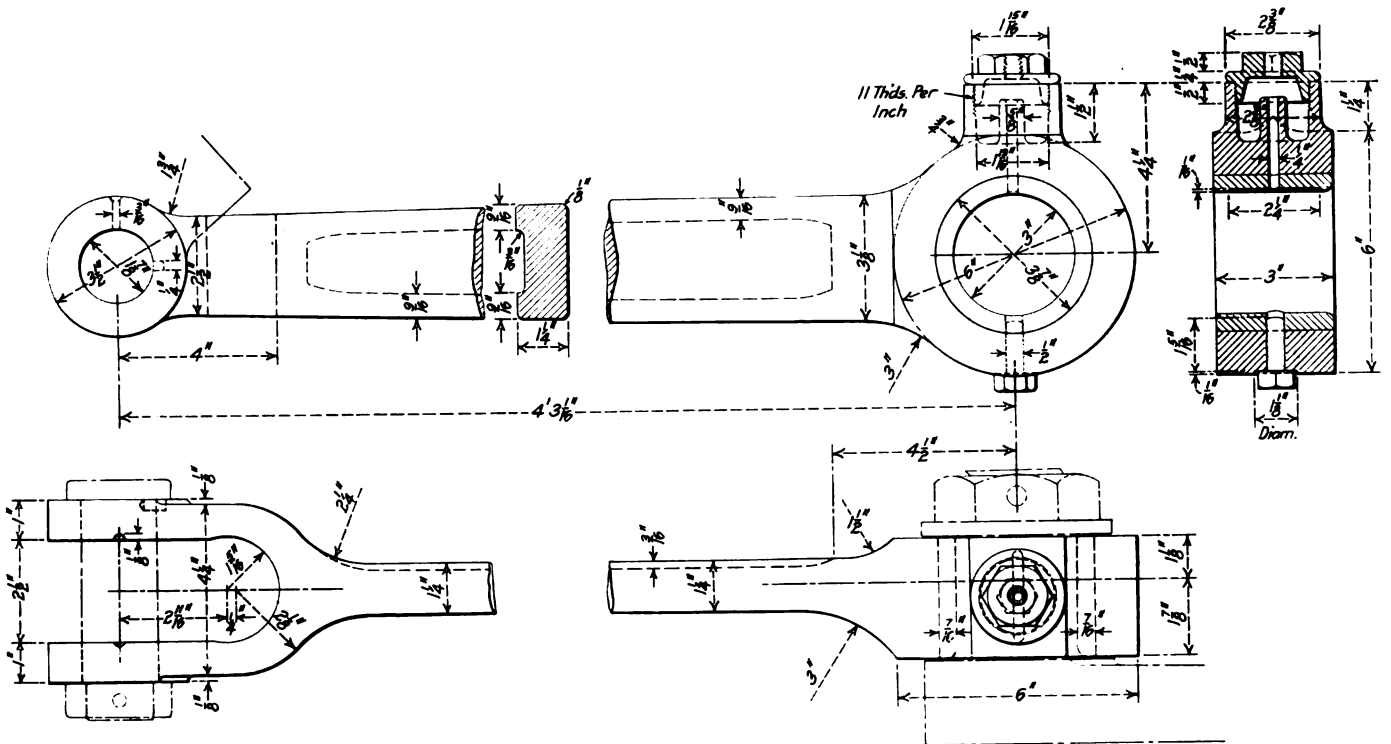

Fig. 52—Eccentric Rod for 4-6-4 Type Locomotive

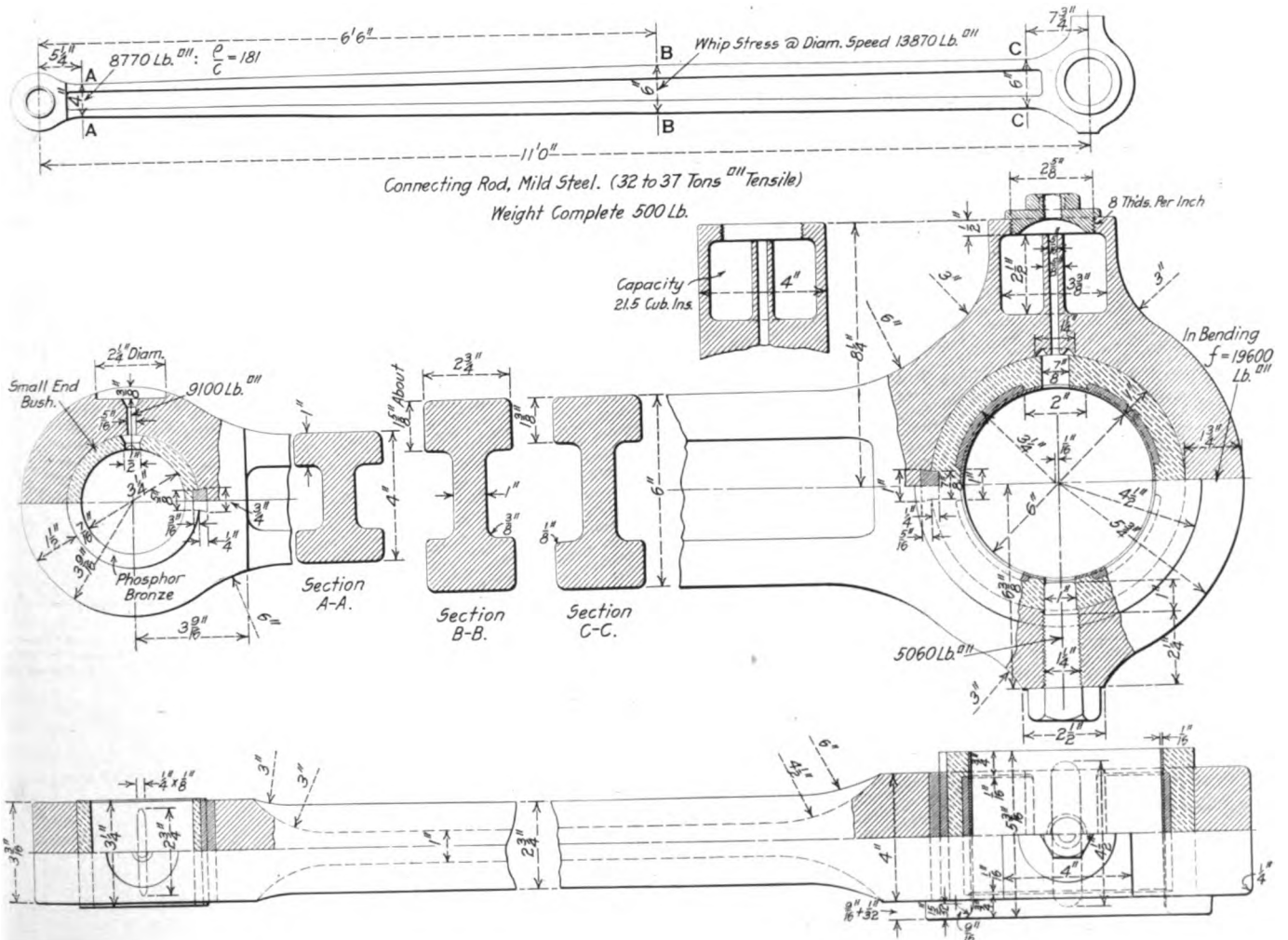
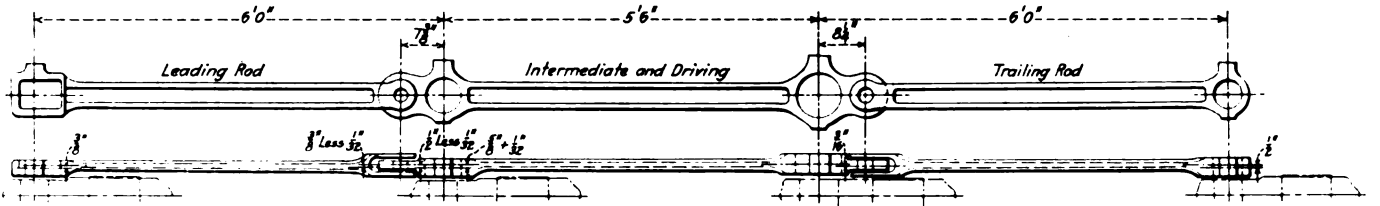

Fig. 53—Main Rod of Somerset & Dorset Joint Railway 2-8-0 Type Locomotive



Rod, Mild Steel. (32 to 37 Tons^m Tensile) 72,000 to 83,000 Lb.^m
Weight 330 Lb.

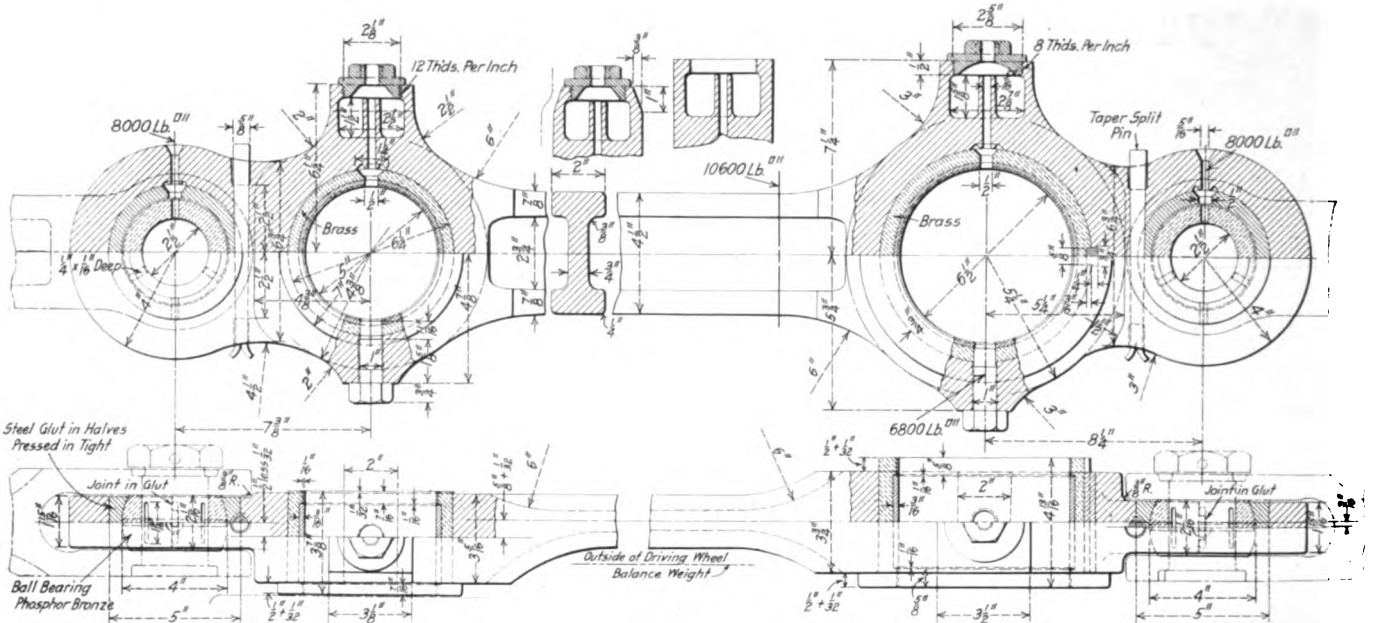

Fig. 54—Intermediate Side Rod for Somerset & Dorset Joint Railway 2-8-0 Type Locomotive

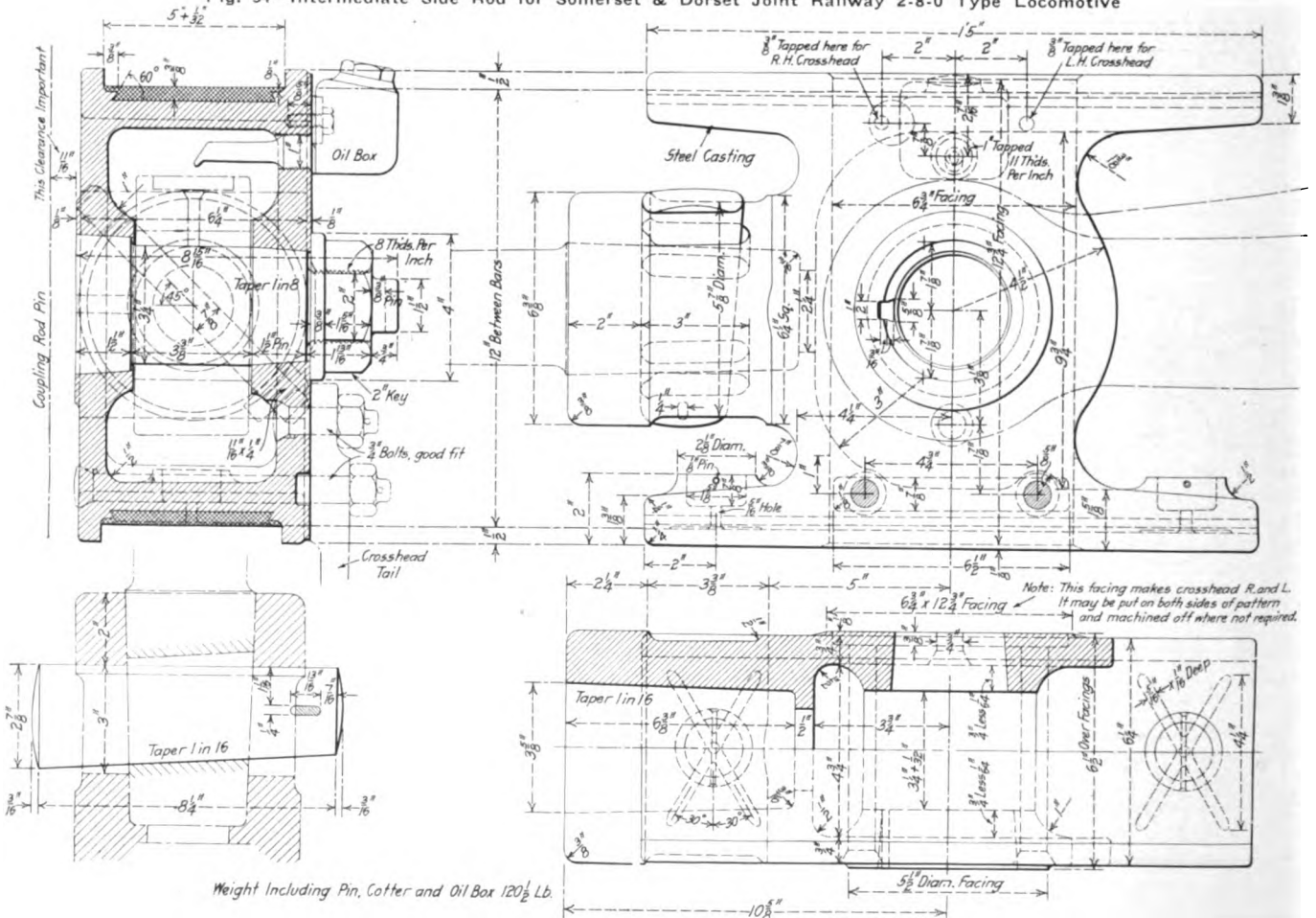

Fig. 55—Crosshead of 2-8-0 Type Locomotive

TABLE XVII—STRESSES IN PISTON ROD AND CROSSHEAD OF SOMERSET & DORSET JOINT RAILWAY (MIDLAND) 2-8-0 TYPE LOCOMOTIVE

Section, and kind of stress	Amount of stress, lb. per sq. in.
Shear on key.....	13,700
Tension in rod through keyway.....	11,500
Tension in neck of crosshead through keyway.....	4,200
Crushing of key on the rod.....	22,500
Crushing of key on the crosshead.....	25,500
Bearing pressure, pin on crosshead.....	6,200
Compression in main shank of rod.....	8,500

strength of 63,000 to 80,000 lb. per sq. in. with an elongation of not less than 18 per cent in 2 in. This crosshead with its pin and key and combining lever arm weighs only 137½ lb., and by referring to Table XII it will be found that it carries 480 lb. of piston load per pound of weight, which is remarkable.

Briefly, the writer has tried in these articles to cover the details of some of the latest American and English designs

LOCOMOTIVE HEADLIGHT REQUIREMENTS

BY E. S. PEARCE

Special Engineer, Cleveland, Cincinnati, Chicago and St. Louis, Indianapolis, Ind.

For the last seven or eight years the legislatures of several states have been active in the enactment of laws relative to locomotive headlights. As a result the subject is more or less inadequately covered by laws of a miscellaneous character and rather indefinite nature, thus causing much embarrassment to the railroads engaged in interstate operation, in their efforts to comply with them. Before going into a discussion of present conditions, a definite idea of the nature of the subject concerning which so much work has been done by both the railroads and the state authorities is essential.

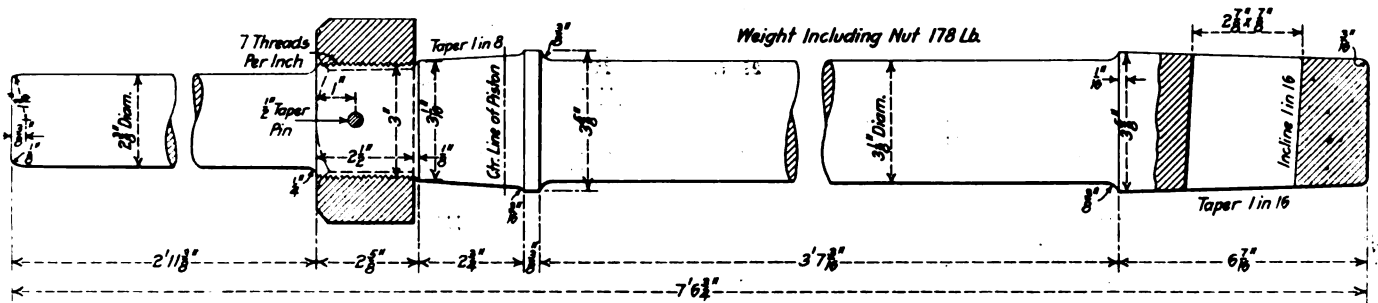

Fig. 56—Piston Rod for Somerset & Dorset Joint Railway 2-8-0 Type Locomotive

of reciprocating and revolving parts. If it shall serve only as a reference and guide for future work it will have served some purpose. In the case of the American locomotives new ground has been broken, and yet the design of these parts can hardly be said to be an experiment. The weight reduction in some of the parts has been startling, but this actual reduction in weight has at the same time reduced some of the stresses, in addition to lightening the pressures on the bearing surfaces. In each case the results have been obtained by a determination not to be hampered by past practice. Every detail has been considered; it has been the saving of a pound here and a pound there that has made a final total saving that has been worth while. This work shows, it is believed, the tendency of locomotive practice in America to-day—the practice of taking each part in detail and studying it in order that the whole may produce a more efficient and a safer machine.

In closing the writer wishes to acknowledge his thanks to J. T. Wallis, general superintendent of motive power, Pennsylvania Railroad; F. A. Torrey, general superintendent of motive power, and C. B. Young, mechanical engineer, Chicago, Burlington & Quincy; F. J. Cole, consulting engineer, American Locomotive Company; J. R. Gould, superintendent of motive power, Chesapeake & Ohio, and to G. J. Churchward of the Great Western, H. Fowler of the Midland, and L. B. Billinton of the London, Brighton & South Coast Railways of England.

DETERMINING THE TEMPERATURE OF OIL QUENCHING BATHS.—The temperature of oil baths for drawing the tempers of tools should be indicated by a thermometer rather than by a pyrometer, because most pyrometers are subject to considerable error at temperatures below 800 deg. F. Thermometers are simpler and not so likely to get out of order.—*Machinery*.

TASMANIAN COAL.—There are abundant seams of marketable coal in Tasmania. They belong to the permo-carboniferous and mesozoic measures, and range from 20 in. to 12 ft. in thickness. In the basin of the Mersey the seams belong to the oldest measures. In the eastern part of the island those of younger age prevail. Eleven collieries are now engaged in producing coal in Tasmania. The output in 1910 was 82,445 tons.—*Engineering*.

Light may be defined as that which is capable of affecting the sensation of sight, optics being that particular branch of science dealing with the subject. After a considerable amount of research it has been long established that light is a wave motion, and that each particular color of light has a different wave length, varying from .000077 c.m. for red to .000039 c.m. for violet light. Objects are made visible to the human eye by the light rays which are transmitted to the eye, either by reflection of rays from the object to the eye, or by light diffused through an object to the eye. An example of reflection is the visibility of an object located in the path of a beam of light from a headlight; an example of diffusion is the light transmitted to the eye by rays from a signal lamp, the light here being diffused through the lens. That light which is reflected or diffused by or through an object determines the color of the object; or in other words, an object is red because it reflects or diffuses red light rays to the eye, all other rays not being transmitted. Black and white are not considered colors, strictly speaking, for black absorbs all light rays, reflecting or diffusing none, while white reflects or diffuses all light rays, absorbing none.

Light may be classified as to source, as natural and artificial light, natural light being the light originating in the sun, artificial light originating in the flame of an oil or gas light, or the arc of an electric light, or the filament of an incandescent bulb. In order clearly to see an object with the naked eye, the following conditions must be observed:

- 1.—The object must be sufficiently illuminated; that is, enough light must be transmitted from the object to the eye.
- 2.—Intense illumination is as much to be avoided as too little. Strong light causes contraction of the eye muscles, and in the event of intense light, the nerves of the eye become paralyzed.
- 3.—All lights other than those necessary to properly illuminate the field of vision should be eliminated, for by contrast the visibility of the object will be impaired.
- 4.—The source of illumination should be constant as to intensity, as a flickering light requires too numerous and rapid adjustments of the eye muscles.
- 5.—The illuminating rays should be of uniform intensity; that is, streaks of bright light are to be avoided.
- 6.—The object should contrast sufficiently with the surroundings.

Among the terms most commonly used in speaking of the relative intensities of different sources of illumination are candle power, foot-candles, lumens, and apparent beam candle power. These may be defined as follows:

Candle Power.—The quantity of light emitted from any source is measured in candle power, a candle power being the amount of light emitted in one second by a sperm candle burning 120 grains per hour.

thrown upon a surface from a source of light by virtue of its being so projected by means of a reflector is measured in apparent beam candle power. To produce the same number of foot-candles from an unreflected source of light would, therefore, require a source of greater intrinsic candle power. That the intensity of the illumination varies inversely with the distance from the source may be seen from Fig. 1 at B. At a distance d , the density of the illumination would be D lumens, while at a dis-

LOCOMOTIVE HEADLIGHT REQUIREMENTS IN THE VARIOUS STATES

State.	Kind of Light.	Candle Power.	Power measured with Reflectors.	Distance.	Objects to be Discerned.	Engines Affected.	Remarks.
Arizona	Electric	1,500	No	Switch Engines Exempt	
Arkansas	Optional	1,500	
California	Optional	800 ft.	Man.	Passenger and Freight	
Colorado	Optional	1,200	No	Switch Engines Exempt	
Florida	Optional	2,500	Switch Engines Exempt	
Georgia	Electric	23 in.	Switch Engines Exempt	300 watts at the arc required.
Illinois	Optional	800 ft.	Man.	Passenger	
				450 ft.	Man.	Freight	
				250 ft.	Man.	Switch	
Indiana	Optional	1,500	No	Switch Engines Exempt	
Iowa	Optional	1,100 ft.	Passenger and Freight	
Kansas	Optional	800 ft.	Man.	Passenger and Freight	
Michigan	Optional	350 ft.	Whistle Post	Passenger and Freight	
Minnesota	Optional	1,500	No	Passenger and Freight	
	Optional	50	No	Switch	
Mississippi	Electric	18 in.	Switch Engines Exempt	300 watts at the arc required.
Missouri	Electric	1,500	Yes	Switch Engines Exempt	
Montana	Optional	1,500	No	
Nebraska	Optional	1,500	600 ft.	Man.	Passenger and Freight	
Nevada	Optional	1,500	Switch Engines Exempt	Engine to and from shops exempt.
New Mexico	Optional	1,500	No	800 ft.	Man.	Switch Engines Exempt	
North Carolina	Electric	1,200	No	Switch Engines Exempt	
North Dakota	Optional	1,200	No	Switch Engines Exempt	
Ohio	Optional	350 ft.	Whistle Post	Passenger and Freight	
Oklahoma	Optional	1,500	No	
Oregon	Optional	800 ft.	Man.	Passenger and Freight	
South Carolina	Optional	10,000	Yes	800 ft.	Man.	Passenger and Freight	Engine to and from shops exempt.
South Dakota	Optional	1,500	No	Switch Engines Exempt	
Texas	Optional	1,500	No	Switch Engines Exempt	
Texas	Optional	2,500	Yes	450 ft.	Switch Engines Exempt	
Vermont	Optional	500	Yes	Switch Engines Exempt	A. R. M. M. A. recommendation.
Virginia	Electric	All Locomotives	A. R. M. M. A. recommendation
Washington	Electric	All Locomotives	To be approved by Ry. Com.
Wisconsin	Optional	800 ft.	Man.	

*Special exemptions as to length of interstate or intrastate operation.

Foot Candles.—The unit of density of the illumination emitted from a source of light is termed the foot-candle, as shown in Fig. 1 at A. The illumination falling on any point X_1 , of the plane XY , which is one foot distant from the source I of one candle power, is one foot candle.

Lumen.—The intensity of the light given a surface by a source

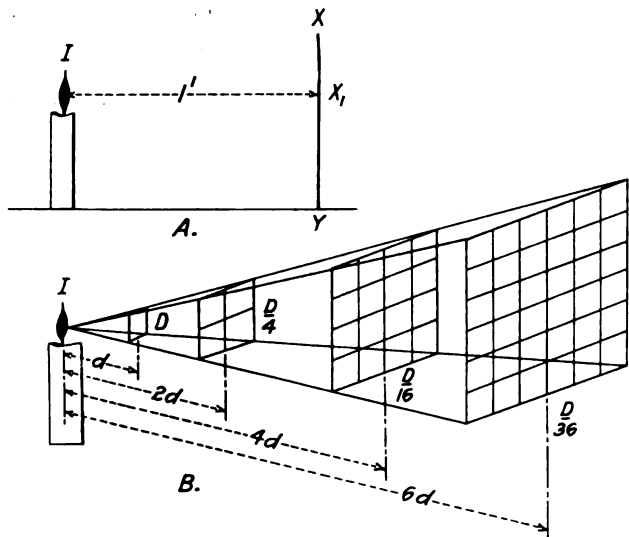

Fig. 1—Diagram Showing How the Intensity of Light Varies

of light is measured in lumens per square foot; that is, a surface one square foot in area, one foot from a source of illumination of one candle power, receives an illumination of one foot-candle upon every point within that area.

Apparent Beam Candle Power.—That amount of illumination

tance $2d$, the density would be $D \div 4$ lumens.

The quantity of light emitted from a source of illumination is measured by means of the photometer, the quantity being expressed in candle power. Fig. 2 shows a simple form of photometer, the operation of which is based on the principle of inverse squares, as stated above. The apparatus consists of a standard candle I , placed a fixed distance from the screen S ; two mirrors M_1 and M_2 ; two partitions A , with circular openings the same size, placed equidistant from S ; a scale C , used to indicate the distance Y of the light L , of unknown candle power, from the screen S ; two openings O which enable the operator to simultaneously observe the two mirrors M_1 and M_2 , the whole enclosed in a light-proof box and operated in a light-proof room. On the screen S is a small grease spot D , by means of which the light from I is diffused through S and reflected in the mirror M_2 , while the light from L is diffused and reflected in the same manner through S on M_1 . By observing the two reflections in M_1 and M_2 , through O , the experimenter regulates the distance of the light L of unknown density from S , until the image of the grease spot in both mirrors disappears on account of the reflecting and diffusing of the two sources being equalized, which occurs when the candle powers I and L are to each other as the squares of their respective distances from the screen S . With a standard candle I one foot from the screen and a light L three feet from the screen, with no image of the grease spot in either mirror, the density of illumination of the unknown light would be known to be nine candle power.

The amount of illumination necessary to enable an object to be seen, or the number of foot-candles required, varies widely on account of the following conditions: Eyesight of the observer; coefficient of reflection of the object, or the ability of the surface receiving the light rays to reflect them; contrast between the light reflected by the object with that reflected by the sur-

roundings, and the alertness of the observer, whether forced or natural, due to occupation and habits.

The Master Mechanics' Association committee on Locomotive Headlights in its report shows that a dark object the size of a man could be seen at 450 ft. with an illumination of approximately .038 foot-candles. A similar medium-colored object was seen at 625 ft. by an illumination of .028 foot-candles, and a light-colored object was seen at 975 ft. with an illumination of .008 foot-candles. The method of conducting these tests took into consideration the four conditions cited above. The intensity of the illumination to which the eye can adjust itself varies considerably. A normal eye can work well with light varying in intensity from fractions of a foot-candle, as cited from the committee report, to five foot-candles, the latter, however, usually being higher than the eye can advantageously utilize. The injurious effects of lights having a high beam candle power, was clearly demonstrated in the headlight committee's test at Columbus, classification lights disappearing at 40,000 apparent beam candle power when the observer was confronted by a light of such intensity.

In view of the foregoing facts concerning the nature, propagation and theory of light and the conditions necessary to adequate illumination, the problem the state legislatures have at-

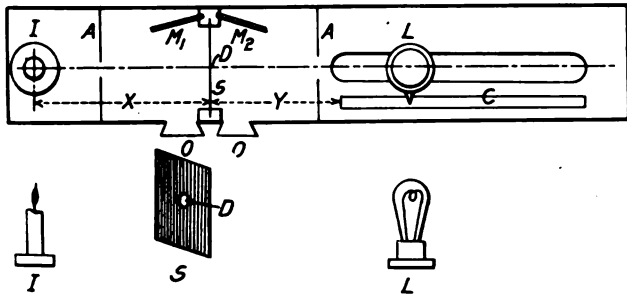

Fig. 2—A Simple Photometer for Determining the Candle Power of Lights

tempted to solve by enacting the present headlight laws will be seen to be of a more complex nature than was evidently appreciated by the instigators of the various bills. From the accompanying table it will be seen that there are 12 states east of the Mississippi river with headlight laws, and 18 states west of the Mississippi. It can readily be seen from this that the haste of the various state legislatures in making laws on a subject requiring considerable investigation, not only by experts on the subject of illumination, but more especially by men actually engaged in the operation of the railroads, has resulted in the enactment of laws which show a disregard for the fundamental principles involved. This fact is evident from the statements of requirements which specify candle powers of high value—too high for safety, as has been demonstrated—the candle powers to be measured with and without reflectors, as the case may be, regardless of the fact that the reflector is as much a part of the light as the flame itself, so far as adequate illumination is concerned. The candle power of the light is not the important factor, but the foot-candles thrown upon the object to be seen.

It is worthy of note that two states, Vermont and Virginia, have taken advantage of the results of the exhaustive tests conducted by the Master Mechanics' Association Committee on Headlights. Vermont has enacted a law, effective April 1, 1915, which in substance states that a light of 2,500 apparent beam candle power measured with the aid of reflector, such readings of candle power being taken on a reference plane 3 ft. above the rail at distances between 500 and 1,000 ft. in the center of the track, the minimum beam candle power to be required at each station being specified, will meet the requirements of an efficient headlight, thus conforming to the recommendations of the Master Mechanics' committee.

Such a law eliminates the necessity of using a high power electric headlight, the use of which has been demonstrated to be a dangerous practice, and admits all makers of such ap-

pliances to the field of development, whether their product be oil, gas, or electric. From the present status of the subject as regards state laws, it is evident that until such time as a federal law is enacted which will adequately aid fairly cover the various conditions to be encountered in train operation, the railroads are going to be subjected to constant annoyance and considerable expense in their efforts to comply with laws, indefinite, inadequate and impracticable in nature, the enforcement of which cannot be justly carried out by the state authorities.

DIAGRAM FOR DETERMINING PERCENTAGE OF MAXIMUM TRACTIVE EFFORT

BY L. R. POMEROY

The illustrations show a method of determining by the means of combination curves the percentage of the maximum tractive effort which is available with various speeds, diameters of driving wheels and stroke. Consider for example a Consolidation type locomotive with cylinders 25 in. by 30 in., 52 in. diameter driving wheels, 217,500 lb. weight on drivers, 27,000 lb. on the engine truck. The tender weighs loaded 170,000 lb., giving a total weight of engine and tender of 421,500 lb. The locomotive has 202 sq. ft. of firebox heating surface, 26.5 sq. ft. of arch tube heating surface, a tube heating surface of 2,919 sq. ft. and a superheater surface of 594 sq. ft. Taking one and one-half times

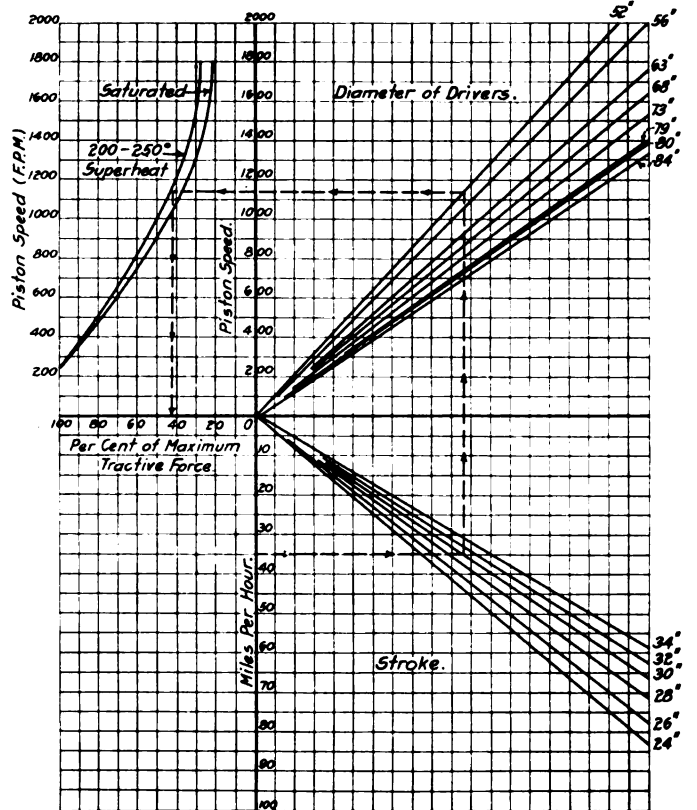

Diagram for Obtaining the Percentage of the Maximum Tractive Effort Under Various Conditions

the superheater surface the total equivalent heating surface is 4,038.5 sq. ft. The maximum speed at which the locomotive can exert its maximum tractive effort is $\frac{125 \times 4038.5}{61298 \text{ lb.}}$ = or 8.2 miles per hr., the maximum tractive effort being 61,298 lb.

In order to determine the gain or loss if the speed of operating the locomotive is increased from 35 miles per hr. to 45 miles per hr., we may read from the diagram the piston speed and the percentage of the maximum tractive effort obtainable at 35 miles per hr., the latter being 43 per cent. and the piston speed 1140 ft. per min.; at 45 miles per hr. the piston speed is 1480 ft.

per min., and the available tractive effort is 32 per cent. of the maximum. The increase in speed is $\frac{45}{35} - 1 = \frac{45}{35} - 1 = 28$ per cent. and the equivalent decrease in tractive effort is $1 - \frac{32}{43} = 25\frac{1}{2}$ per cent.

Assuming that the gross ton-miles, which takes account of the entire weight of the engine, tender and train, is proportional to the miles per hr., multiplied by the percentage of available tractive effort at different speeds, the percentage of the gross ton-miles is
 35 m. p. h. x 0.43=15.05
 45 m. p. h. x 0.32=14.40

The percentage of gross ton-miles at 35 miles per hr., as compared with that at 45 miles per hr. then equals $\frac{15.05}{14.40} - 1 = 5$ per cent. greater at 35 miles per hr. than at 45 miles per hr. This consideration is entirely aside from a disadvantage from a mechanical and maintenance standpoint of increasing the piston speed from 1140 ft. per min. to 1480 ft. per min., while the decrease in horsepower also amounts to 4 per cent. With this particular locomotive the average horsepower at 35 miles per hr. and 45 miles per hr. is about 2200. (The maximum h. p. is reached at a piston speed of 1000 ft. per minute, beyond which the h. p. diminishes). At the rate of 2.7 lb. of coal per h. p. hr. the coal per hr. necessary to develop this h. p. would be 5,940 lb., which is about the limit of the average fireman under the most favorable conditions.

When the calculation is based on the available trailing load or the drawbar pull, the disadvantage of increasing the speed from 35 miles per hr. to 45 miles per hr. is considerably greater.

At 35 miles per hr. under the conditions named:	
Maximum available tractive effort, 61,298, at 43 per cent.	= 26,358 lb.
Engine friction, weight on drivers x 1.11 per cent.	= 2,414 lb.
Weight on engine truck + 2/3 weight of tender=145,000 lb. at 2 lb. per 1,000 lb.	= 290 lb.
Head end resistance .002 x (mph) ² x 120 sq. ft area.	= 294 lb.
	2,998 lb.
16 deg. curve (equivalent to 0.64 per cent. grade, or 12.8 lb. per ton) weight of engine and tender in tons x 12.8	= 2,317 lb.
3 per cent. grade, 181 tons at 6 lb. ...	= 1,086 lb.
	6,401 lb.
Total locomotive resistance.	6,401 lb.
Net available tractive effort.	= 19,957 lb.
Available tons back of drawbar for 70-ton cars (tare and lading) 3 lb. per ton + 16 deg. curve + .3 per cent grade (3 + 12.8 + 6) = 21.8 lb. resistance of trailing load = $\frac{19957}{21.8}$...	= 917 tons
At 45 miles per hr.:	
Maximum tractive effort, 61,298 at 32 per cent.	= 19,615 lb.
Engine friction, as above (2414 + 290)	= 2,704 lb.
Head end resistance (.002 x (mph) ² x 120 sq. ft.)	= 486 lb.
Resistance of 16 deg. curve .3 per cent. grade (2317 + 1086)	= 3,403 lb.
	6,593 lb.
Total engine resistance.	6,593 lb.
Net available tractive effort.	= 13,022 lb.
Available tons back of drawbar for 70-ton cars	

(curve, grade and friction) (3.25 + 12.8 + 6)
 as above $\frac{13022}{22.05} = 591$ tons
 Ton-miles per hour
 (a) 35 mph x 917 tons. = 32,095 ton-miles
 (b) 45 mph x 591 tons. = 26,595 ton-miles
 In favor of 35 miles per hr.: $\frac{32095}{26595} - 1 = 20$ per cent.

ROAD TESTS FOR DETERMINING FRONT END CONDITIONS

BY E. S. BARNUM

The problem of proper drafting has been a live subject since the locomotive was in its infancy. It is doubtful if we could find a roundhouse foreman who did not think he could give the last word on the proper way to make a locomotive steam. However, when his practice was analyzed, it would be found that in 99 cases out of 100, the exhaust nozzle had been so much reduced that the locomotive could not help steaming. Reductions in the size of the exhaust nozzle are usually made without regard to the high back pressure caused in the cylinders, which

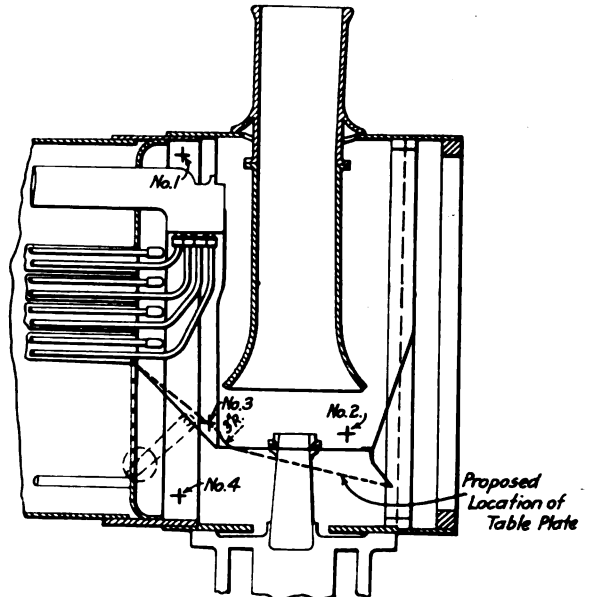

Fig. 1—Draft Readings to Determine Condition of Passages

means a logy engine and an increase in the coal consumption. On a very few of the largest railroads, having a testing plant or access to such facilities, front end arrangements can be tried out and standards established for the various classes which will give satisfactory and economical results. But how are roads without access to such facilities to obtain indication of any accuracy as to the efficiency of front ends? A possible answer is that it is unnecessary, as the locomotive builders take care of the design and furnish front ends which fulfill the conditions; but it would not take a very deep or extensive investigation to disprove this. The most satisfactory method is to make road tests under service conditions. If the underlying principles are well understood, reliable data can be secured with the help of not more than two observers using very simple and inexpensive apparatus. Operating conditions do not have to be disturbed in the least. The front end does work in producing draft and it does this work at the expense of back pressure in the cylinders. The measure of the efficiency of a front end is the number of units of draft it will produce per unit of cylinder back pressure. However, with the same style of nozzle, the back pressure varies

inversely with the area of the nozzle, and as we must have a locomotive that will steam, it is not essential that we measure the back pressure with indicators. What is necessary is to measure the amount of draft in a number of places in the front end and localize the points at which there are serious losses in the velocity of the gases.

Doctor Goss and other experimenters have proved that to

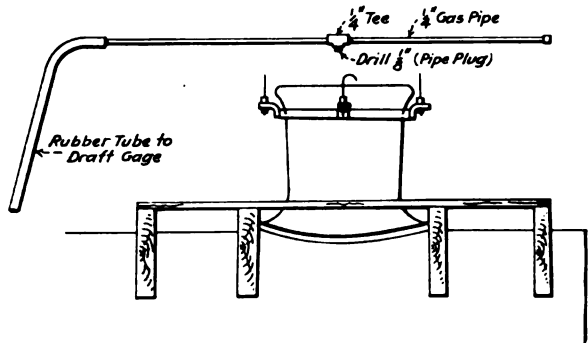

Fig. 2—Apparatus for Determining the Condition of the Exhaust in the Stack

secure the best results, the following conditions must obtain :

- 1.—The exhaust element (exhaust column, nozzle, lift, pipe and stack) must be in line.
- 2.—The gas passages in the front end should be smooth and free from angles which tend to cause eddies and unnecessary friction.
- 3.—The exhaust should fill the stack at a point about three or four inches from the top.
- 4.—There should be no obstructions in the path of the exhaust, as they influence it, and objects near the exhaust have the same influence in a lesser degree.

The exhaust elements should be lined up in the shop previous

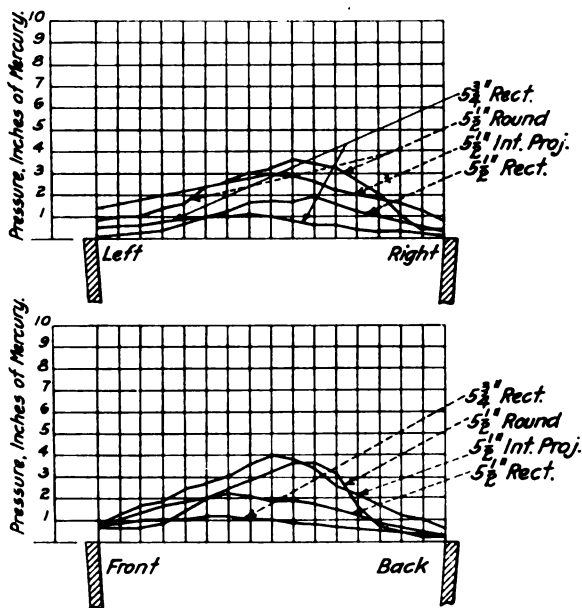

Fig. 3—Draft Readings Taken at the Top of the Stack

to the road tests. This leaves three conditions to obtain by trying out under actual operating conditions. By selecting runs, fairly uniform tonnage may be secured. As the tests should be over the same piece of road each trip, the conditions are similar.

In order to determine whether or not the gas passages of the front end are smooth and do not offer too much friction, draft readings should be taken simultaneously at a number of locations. Fig. 1 shows such locations on a locomotive with a super-heater. The readings are secured with an ordinary U draft gage placed in the cab, suitable piping being provided for the

purpose. Some actual results obtained in tests are shown below.

Location	No. 1	No. 2	No. 3	No. 4
Draft—inches of water..	5.1	9.1	5.1	5.8

Readings at location No. 2 show quite a variation from the other three. The trouble has been localized and we should rearrange the table plate and remove the adjustable diaphragm as indicated by the dotted line in Fig. 1.

Next we come to the location of the exhaust in the stack.

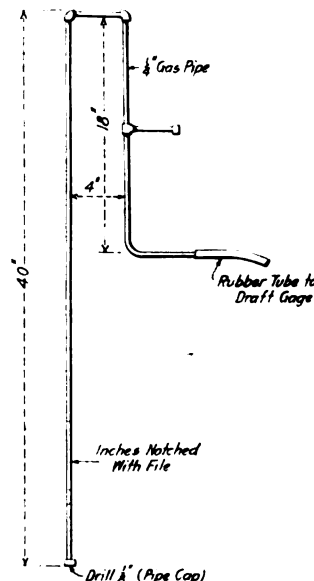

Fig. 4—Device for Locating the Point at Which the Exhaust Strikes the Stack

Referring to Fig. 2, it will be noted that a wooden platform has been built around the stack large enough to accommodate an observer. There is a band around the stack having four hooks which project above the stack and in which a 1/4-in. pipe can be slipped. This section of pipe is shown just above the stack and

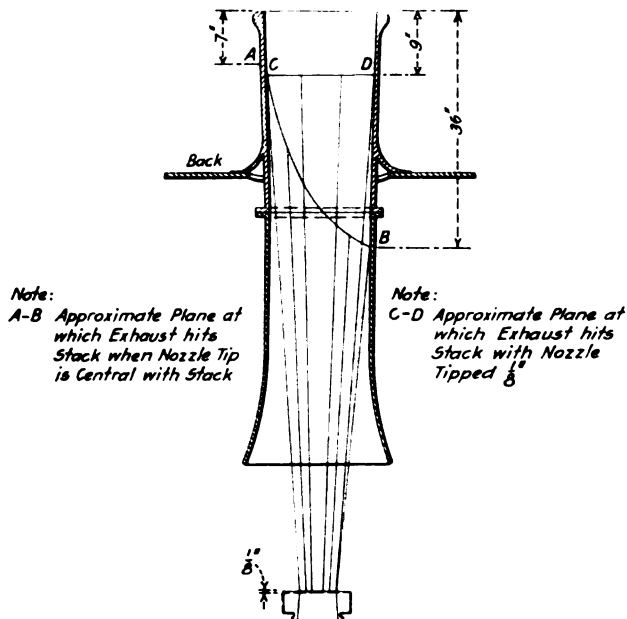

Fig. 5—Stack Conditions as Determined by the Apparatus Shown in Fig. 4

it will be noted that there is a tee in the center in the lower opening of which there is a pipe plug which has a 1/8-in. hole drilled in it. By moving the pipe across the stack an inch at a time with the tee pointed downward a series of readings will be obtained on the draft gage, which, when plotted, will give curves as shown in Fig. 3.

An arrangement for locating the point at which the exhaust

strikes the stack is shown in Fig. 4. The end with the pipe cap on it is moved up and down against the inside of the stack until the point of no pressure, or vacuum, is located. This is the point at which the stream of exhaust steam just begins to come in contact with the stack and it can be located within an inch. Several of these points located around the stack will give a plane as indicated in Fig. 5. It will be noted that the exhaust was hitting the stack 9 in. from the top at the back and 36 in. from the top at the front. This was a condition found in actual road tests and the cause can only be found by a process of elimination. On lowering the nozzle $\frac{1}{8}$ in. at the back the exhaust hit the stack squarely all around.

Different depths of fire in the firebox will cause a variation in the amount of draft in the front end. This is a fact the observer should not lose sight of. If, however, his draft readings have been taken from the different locations at the same time, the relation between each set of readings will necessarily be the same.

MODEL LOCOMOTIVE BUILT BY APPRENTICES

A complete working model of a Pacific type locomotive has recently been completed by the apprentices at the Dunmore, Pa., shops of the Erie Railroad. This work was undertaken under instructions from the management as a test of the proficiency of the boys in reading drawings and working to scale,

handle the work. This was assigned to one of the gangs which designed and constructed a small lathe, drill press and shaper. The task of building a small motor being assigned to the electrical apprentice. The building of these tools was necessary because the small size of the model made the use of the machine tool equipment in the main shop impracticable. While the machine tools were being built a set of small taps and dies were made by the tool room apprentice.

To the second gang was assigned the preparation of a set of drawings of the locomotive details to the required scale, and as fast as these were completed the pattern shop apprentices were started on the construction of the necessary patterns. These were turned over to the foundry apprentices and castings made. At the end of ninety days the two gangs, with the assistance of the electrical, patternmaker and foundry apprentices had converted the apprentice schoolroom into a locomotive shop which was stocked with enough material to provide for the beginning of actual work on the model, the third gang being added to the force at this time.

Considerable ingenuity was exercised in meeting the demand for special classes of material from the resources at hand. Sewing needles were used to provide hardened pins $\frac{1}{64}$ in. in diameter for use in the Baker valve gear, and air hose was obtained by stripping the insulation from No. 28 copper wire.

Work was started during the month of September, 1915, and in 200 working days the model was completed ready for shipment to the office of the general mechanical superintendent in

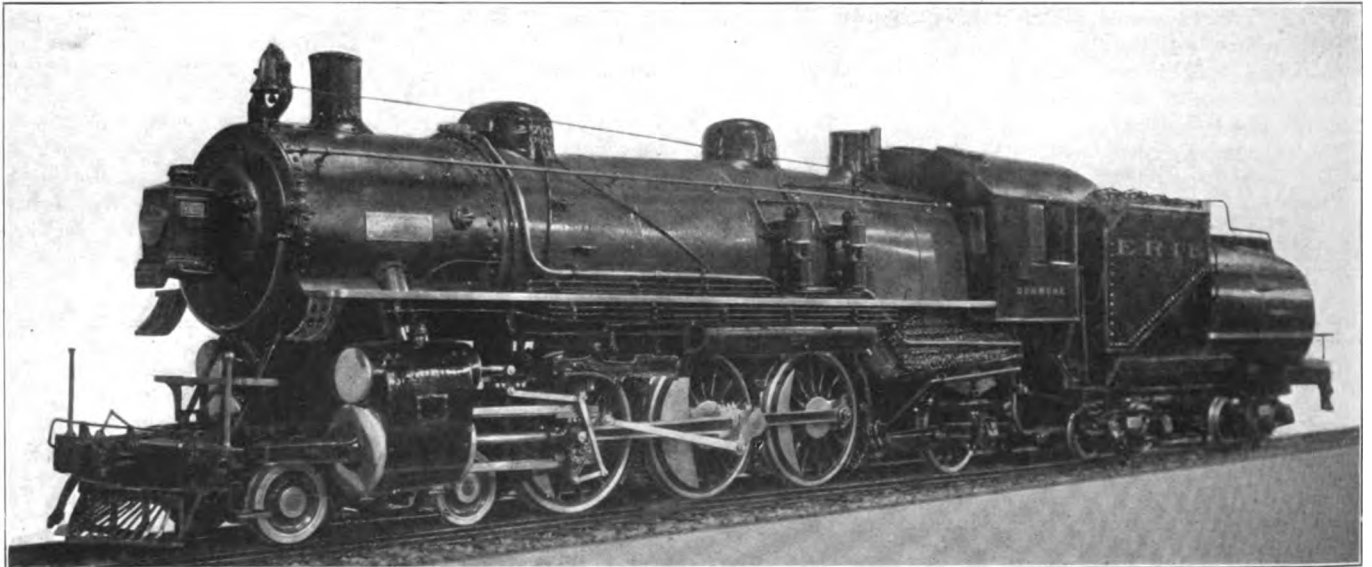

Model Locomotive, 57 Inches Long, Built by Erie Apprentices at Dunmore, Pa.

and the engine was built from the drawings of a class K-4 Pacific type to a scale of $\frac{3}{4}$ in. per foot. It is 57 in. long over all and rests on a short section of stone ballasted track of $3\frac{5}{8}$ in. gage.

The instructions authorizing the building of the model specified that it was not to interfere in any way with the regular shop work, and it was therefore built entirely in the schoolroom, the work being done by the apprentices under their own shop organization. One of the boys was appointed general foreman by the instructor; a set of blue prints turned over to him and the completing of the organization and the prosecution of the work was left in his hands. Two other foremen were selected by him and the three then decided to select fifteen apprentices from the various departments to be worked in gangs of five boys each under the supervision of the three foremen.

The next step was the equipping of a small machine shop to

New York City. It was built under the supervision of H. E. Blackburn, apprentice instructor at Dunmore, and is now being exhibited in the window of the Erie's uptown ticket office at Broadway and Thirty-third street, New York.

ALUMINUM.—The consumption of aluminum is constantly expanding. It is the most abundant of metals and ranks third among the elements which compose the crust of the earth, being exceeded only by oxygen and silicon. According to the United States Geological Survey the quantity of aluminum consumed in the United States in 1914 was 79,129,000 lb., against 72,379,000 lb. in 1913, and 65,607,000 lb. in 1912. The growth of the industry is shown by the fact that the production was 150 lb. in 1884, 550,000 lb. in 1894, and 8,600,000 lb. in 1904. The value of the exports of aluminum and of manufactures of aluminum amounted to \$1,546,510 in 1914, as compared with \$966,094 in 1913.—*American Machinist.*

CAR DEPARTMENT

INSPECTION AND REPAIRS OF FREIGHT CARS BY PIECEWORK*

BY J. J. TOLIN
Foreman Car Repairs, Pennsylvania Railroad

The inspection and repairs of freight cars on a shop repair track should be divided into three classes:

(1) Light repairs which should take in the renewal of wheels, couplers, draft timbers, arch bars, and all repairs of a minor nature.

(2) Heavy repairs to wood or composite cars, which should include renewal or splicing of sills, renewal of roofs, or the complete rebuilding of car body when found necessary.

(3) Heavy repairs of steel cars, which should include the renewal or splicing of sills, renewal or patching of sheets, or the cutting down and rebuilding of the entire car, when necessary.

Each of these classes should then be sub-divided into two classes, namely: The air brake apparatus and its connections, and the other parts of the car. There should be two sets of piecework inspectors and repairmen, one to be a specialist on the air brake apparatus, and the other on the other parts of the car.

The piecework inspector, supervising repairs to parts other than air brake, should, on the arrival at the repair track of a car requiring light repairs, make a thorough examination of the wheels, journal boxes and contained parts, arch bars, brake-beams, and all parts below the body of the car. At the same time he should note the condition of draft timbers, couplers, end sills, and all parts that are visible from the ground. He should then make the roof inspection, paying particular attention to brake wheel, ratchet wheel, and pawl, to see that the hand brake can be operated, and that the brake pawl will properly engage the teeth of the ratchet wheel. The deck handles and running board also demand preferred attention since they are essential parts. Next the interior of the car should be inspected, assuming that it is an empty house car, and repairs should be made according to the class of freight which the car is to carry.

The authorized piecework card should then be prepared, listing all defects which, in the judgment of the piecework inspector, should be repaired; he should bear in mind that only such repairs as are necessary to make the car safe for trainmen and for lading suitable to it should be made to foreign cars. While making repairs the repairman should be guided by the piecework card and should not be permitted to repair any defect that had been overlooked by the piecework inspector without first calling it to the attention of the piecework inspector and having it added to the piecework card if the inspector decides that the defect should be repaired.

The air brake piecework inspector should make a thorough inspection of the hose, hose couplings, pipe hangers, pipe supports, cylinder and reservoir and their blocks, to see that they are in good condition and firmly secured to the car. He should then fill out the authorized piecework form noting any defect that he may have discovered.

The car is now ready for the air brake repairman. He should first read the piecework card and then proceed to make the repairs. When this has been done he should attach the yard air line to the air hose at one end of the car and a dummy coupling to the hose at the other end and open the valve from the yard air line. While the system is charging he should disconnect the retaining pipe from the triple valve and place a nipple with an

air gage attached to it in the exhaust port of the triple. Then take a pail of thin soap suds and with the aid of a suitable brush completely cover the air hose and all joints on the brake and cross-over pipe. If a leak in either of these pipes is discovered the piecework inspector should be called to decide whether or not it is of enough importance to repair. When the system is charged and the brakes are applied by making a 25 lb. reduction in brake pipe pressure the length of piston travel should be noted and the brake released by turning the air into the brake pipe through the 1/16-in. opening in the disk located in the 1/4 in. pipe on the testing device. The gage, which is attached to exhaust port of the triple, should be carefully watched for one minute and if it shows a leakage in excess of five pounds the defect causing the leak should be located and repaired. After the defect has been repaired a like test should be made to know that the leak has been reduced below five pounds per minute.

The retaining pipe should then be connected to the triple valve and slack adjusted if necessary, paying special attention to the equalization of the brakes; with the retaining valve handle at right angles on a two position or at a 45 deg. angle on a three position, the brakes should again be applied and released. All joints on the retaining pipe should then be covered with soap suds and all leaks repaired, no matter how trifling they may be; the retaining pipe must be absolutely tight, otherwise it is useless. When the air ceases to escape from the exhaust port in the retaining valve turn down the handle. If a gush of air escapes at this time the retainer is in good condition. If air escapes at a very low pressure or no air escapes the retainer is defective and should be repaired or replaced with a new or repaired valve. Under ordinary circumstances the brakes can now be depended on as being in good condition.

It is, of course, understood that both gangs can be working on the car at the same time and thus not waste any time.

Heavy Repairs to Wood or Composite Cars.—A car of this type requiring heavy repairs should be jacked up, placed on trestles and the trucks removed from underneath the car body before inspection is made. The inspector should first thoroughly inspect the longitudinal sills, end sills, cross-bearers, draft timbers, etc. Taking a box car, for instance, he should determine whether or not the general condition of the car will warrant putting it in condition to carry first-class freight. If he decides that it should be made fit for this purpose he should inspect the siding, lining, flooring and grain strips, condemning any of these parts that are not in perfect condition. The roof should then be thoroughly examined for evidence of leaks and if any are found the necessary repairs should be made. All parts of the trucks should be examined and the piecework form prepared, which should show all repairs necessary, except to the air brake apparatus.

While the car is undergoing repairs the work should be closely checked by the piecework inspector to see that both lumber and bolts of proper dimensions are used, that lumber is properly framed, and that holes bored by the repairmen are not more than 1/16 in. larger than the diameter of the bolts or rods that are to be placed in them. He should also see that all parts are applied as shown on standard drawings; that is, the sizes of tenons, mortices, etc., should not be changed by the repairmen to make the part simpler to apply.

The air brake attention in this case is much the same as in that of the car requiring light repairs with the exception of removing and replacing the apparatus, including the pipe where it interferes with the renewal of longitudinal sills. It is also important in this case that the pipe be thoroughly blown out before it is con-

* Abstract of a paper read at the June 16, 1915, meeting of the Niagara Frontier Car Men's Association, Buffalo, N. Y.

check case and the exhaust port with wooden plugs to prevent dust from entering the triple.

Heavy Repairs to Steel Cars.—The all-steel car does not require heavy repairs as frequently as the car of wood construction, but when it does require this class of repairs they are usually more extensive; consequently the number of days out of service per year is approximately the same as that of the wooden car. The number of days out of service can be reduced, however, by increasing the number of men working on the car, and in order to do this and still maintain a high degree of efficiency the men must specialize on some particular kind of work. For instance, cutting off rivets, heating rivets, driving rivets, etc.

My slight experience in the steel car field has taught me that as many as fifteen repairmen can be successfully worked on one car, classified as follows: Cutting off and backing out rivets, four men; repairing bent parts of car, bolting them in place for the riveters and straightening parts on car, four men; reaming and drilling holes, two men; heating rivets, one man; driving rivets, two men; removing and replacing parts that are secured with bolts and repairing trucks, two men. It is, of course, understood that for the practical working out of this arrangement several cars must be on the repair track at one time.

Like the wooden car the steel car should be jacked up, placed on suitable trestles and the trucks removed. All parts that have been affected by corrosion should have the scale removed. The car should then be carefully gone over by the piecework inspector to decide what repairs are to be made and at the same time see to it that no part or parts are removed from the car for repairs that can be successfully repaired in place by using a portable oil heater. He must also exercise good judgment in condemning sheets to be scraped; where it is practicable floor sheets should be patched until an entire new floor is to be applied. When a floor is to be renewed and one or more sheets are found in fairly good condition, they should also be removed and replaced with new sheets and the sheets that are in fairly good condition placed in stock for repairs to floors that are not yet to a point where the entire floor requires renewal.

The splicing of steel longitudinal sills while in place is economical. For illustration, a steel car that has been in an accident and has the longitudinal sills so badly buckled at one or both ends that they cannot be straightened while in place should not be removed for repairs, but the damaged ends should be sawed off, repaired and spliced onto the sills. This can be done at a cost much below that of removing the full-length sills for repairs and the result obtained is just as good, if not better.

The manner in which rivets are driven in steel cars is another important feature. The piecework inspector should inspect each morning all rivets driven by the repairmen the previous day and each rivet should be tapped with a light hammer and any found loose ordered removed. Rivets with poorly formed heads on account of poor heating, or rivets too long or too short, should also be ordered removed and only the rivets that pass inspection should be paid for.

The number of rivets driven should be checked daily by the piecework inspector for the reason that some of them may become covered with other parts and could not be checked at a later date. The rivets that have been checked can easily be identified if bright red paint is used to mark them as they are counted.

The air brake attention necessary is practically the same as in the case of light repairs except that care should be exercised to keep the cylinder, triple valve, cut-out cock, angle cocks, and air hose from coming in contact with excessive heat when straightening parts in place.

A piecework inspector on light repairs should be able to take care of about 20 men; on heavy repairs to wooden cars 30 men, and on steel cars anywhere from 36 to 40.

SHIPS ADMITTED TO AMERICAN REGISTRY.—The total number of foreign-built vessels admitted to American registry to July 31, 1915, was 150 of 528,408 gross tons.—*Iron Age.*

FREIGHT CAR STENCILING OUTFIT

BY H. F. BLOSSOM
Draftsman, Boston & Maine, Concord, N. H.

The stenciling outfit shown herewith has been in use in the Concord, N. H., shops of the Boston & Maine for some time, and has proved very convenient. It is designed primarily for use in re-stenciling weights on freight cars, both in the shop yard and in the classification yard after cars have been re-weighted. Its chief advantages are the convenience with which the stencils and other equipment may be carried about, ready for instant use, and the accessibility of the equipment during the actual process of stenciling the cars.

The outfit consists of a well-built whitewood box, 15½ in. long by 10½ in. wide with a back 9½ in. high, which is concaved to fit against the body. Straps are attached, one to pass around the body and another around the back of the neck, which may be adjusted to suit the operator, leaving the hands free at all times. In each end of the case are compartments fitted with vertical tin partitions for holding the various size stencils in

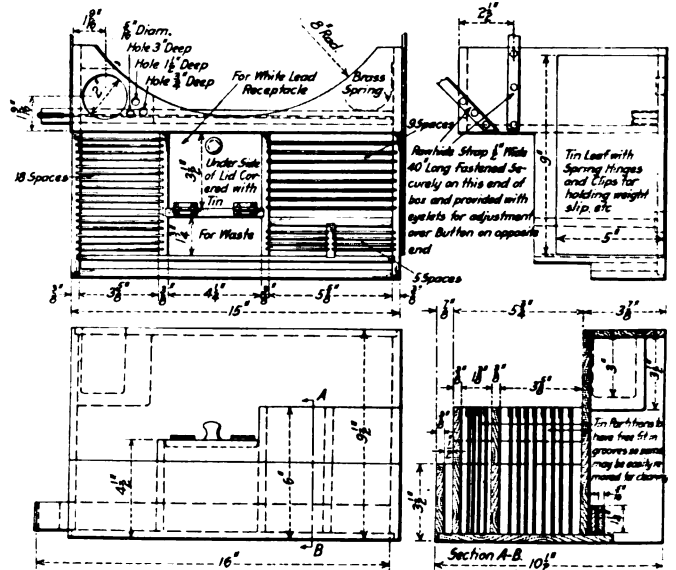

Outfit for Use in Stenciling Cars

numerical order. These partitions should have a loose fit in the grooves so that they may occasionally be removed and cleaned. In front is a space 14¼ in. long for holding longer stencils, such as the words "Weight," "New," etc. One space in the center is used for holding the white lead can and is provided with a hinged lid to keep out dirt. The under side of this lid is covered with tin to provide a palette for the stencil brush. In front of this compartment is a space for holding waste for wiping.

In the back or shield, which bears against the body, is a socket for carrying the stencil brush when it is not in use and three 5/16-in. holes are bored for the marking crayon, these being of different depths to allow for the wear of the crayon. Through a slot in the right-hand side a 32-in. straightedge is inserted behind the shield and is retained by a brass spring clip. On the left side of the box, on the outside, is a tin leaf secured by spring hinges at the bottom and fitted with clips for holding weight slips or other papers. As information is desired the leaf is turned down and the contents consulted. It automatically springs back into place as soon as it is released and the papers are thus secured safely without the attention of the workman.

The complete outfit weighs less than nine pounds, and is therefore no burden to the wearer. This design, of course, may be varied to suit conditions, although this style covers the essential points for the class of work involved.

DESIGN OF STEEL PASSENGER EQUIPMENT

BY VICTOR W. ZILEN

Associate, American Society of Mechanical Engineers

I

Theory and practice as applied to engineering have always seemed to be at variance. This is due to the consideration of one without due regard to the other; the backbone of successful designing lies in a thorough understanding of the relation between the two.

As a rule only the more essential parts of cars receive sufficient consideration from experienced designers, the details being left to beginners. Unfortunately, small details not cared for properly are likely to be a source of trouble from time the plans leave the drafting room until the construction is completed and from the time the car enters service until worn out, resulting in much friction between office and shops, endless correspondence, and in some cases investigations, tests and reports, without the cause ever being determined. A number of small items make big ones, and if the cutting of the weight of a car is essential, it can often be accomplished by cutting the weight of perhaps such things as coat hooks, hat racks, trim-

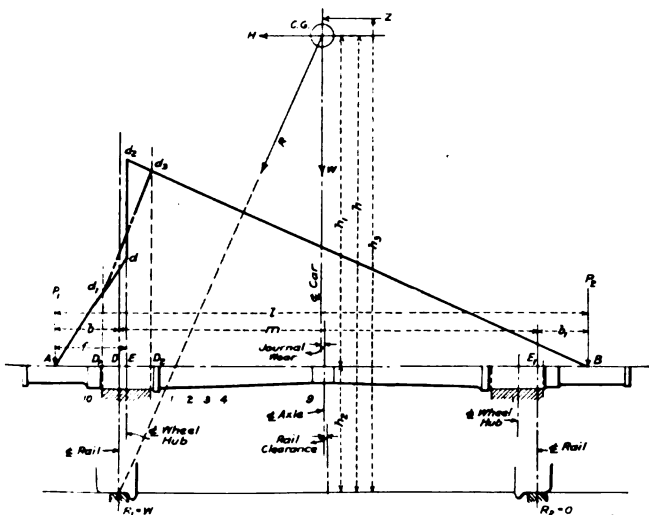

Fig. 1

mings, hardware, plumbing and heating fixtures, bulkheads, flooring, tables and seats and everything else that goes to make dead weight. The designer in charge must be a man whose judgment in passing on a design is final; he must have been in the same boat as the man who is to follow his blue print; he must be familiar with all the shop practices a workman has to contend with and must have had experience that will not permit him to mistake cantilevers and beams for columns and struts, or beams supported at the ends for those which are fixed at the ends; on such things depend largely the strength, weight and cost of the car.

Car construction does not belong to a class of work requiring refinement in machining and fitting of the various component parts, and outside of but few such parts the designer may keep clear of fancy blacksmith and machine work. Not all structural shapes can be worked cheaply in the forge shop; bending channels and angles requires skill and in some cases expensive dies and forms. Pressed sections, while they offer some advantages as to lightness and strength, are often at a disadvantage in making repairs by requiring high-priced labor. A simple pressed section may be used, but built-up sections of structural shapes and rolled bars are preferable.

AXLES.

In beginning this discussion of steel passenger car design, the writer wishes to take up the design of axles. The method of analysis of stresses in car axles which follows bears with

it his acknowledgment of the vast amount of scattered information already available, and all credit is due to the authors of the work previously done. However, some axles designed by either of the generally known methods seem to indicate the advisability of revision and modification of the older formulas.

A general practice is to assume the center of gravity of the car as being six feet from the rail. Assume 26 per cent for vertical oscillation and add to the total vertical pressure on the axle; take 40 per cent of the total vertical pressure on the axle, including the 26 per cent for oscillation, and apply it at the assumed center of gravity of the car. On curves the 40 per cent acts horizontally, perpendicular to the direction of motion, and is supposed to just tip the car over.

But modern steel cars, having a heavy electric lighting equipment suspended underneath, together with heavy underframe construction, no doubt have their center of gravity much lower than six feet above the rail. On cars used in electric service, with heavy electrical equipment, the center of gravity is as low as 50 in. from the top of the rail. By this we see that it will take more than the 40 per cent of the load on the axle to tip the car over, and since it is acting horizontally it will produce an additional flange pressure, which, when multiplied by the radius of the wheel, gives a bending moment to the axle. (See Fig. 1.)

When a car is rounding a curve or passing over switches and frogs, it generates a force by virtue of its own weight and speed. This force acts horizontally and perpendicular to the direction of motion of the car and produces a lateral oscillation.

The force required to tip the car is a maximum when $R_1 = W$ and $R_2 = 0$. Let the intensity of this force = H , and the height of its point of application above the top of the rail = h , we have for the moment M .

$$M = Hh \dots \dots \dots (1)$$

Consider a wind action, Z , acting at its center of pressure above the center of gravity of the car, having for its lever arm the length $(h + x)$. The moment will be

$$M = Z(h + x) \dots \dots \dots (2)$$

But, if the center of pressure is below the center of gravity of the car by an amount, x ,

$$M = Z(h - x) \dots \dots \dots (3)$$

The centrifugal force acting at the center of gravity of the mass considered, combined with Z , will tip the car over when the sum of their moments = Hh ,

Let C = centrif. force

h = the height of the center of gravity above the top of the rail. Then

$$M = Ch, \dots \dots \dots (4)$$

$$\text{Hence } Ch + Z(h + -x) = Hh \text{ or } (C + Z)h = Hh + -Zx$$

So that when the center of wind pressure is above the center of gravity we have from (1), (2) and (4).

$$(C + Z)h = Hh - Zx \dots \dots \dots (5)$$

But if it is below, we have from (1), (3) and (4).

$$(C + Z)h = Hh + Zx \dots \dots \dots (6)$$

From (6), we see that the worst condition is when the center of wind pressure is below the center of gravity of the car, as it shortens the distance h . In order to turn the car over, the horizontal force H will have to be greater, and since its reaction is at the rail it will give a bending moment to the axle.

Having shown how the intensity of the horizontal force H may vary the analysis of stresses in the car axle follows:

- In Fig. 1, let Z = the wind pressure,
- h = height of the center of wind pressure above rail,
- W = the total vertical pressure on the axle, including the weight of the lading and an allowance for oscillation.
- P_1 = vertical pressure on journal at A ,
- P_2 = vertical pressure on journal at B ,
- R_1 and R_2 = reactions at the rails,
- H = horizontal force caused by curves and switches,
- h = height of the center of gravity of the car above the top of the rail,

h_1 = height of the center of gravity of the car above the center of the axle,

h_2 = height of the center of axle above the top of the rail,

l = length of the axle between the points of application P_1 and P_2 of the total load W ,

m = distance between the centers of the rails on curves,

$b = AD$ = distance from the center of rail to the point where the load P_1 acts on the journal.

$b_1 = E, B$ = distance from center of the rail to the point where the load P_2 acts on the journal.

For the maximum conditions of loading, locate the center of gravity of the car and determine the center of wind pressure on the projected area of the car, on the vertical plane; if h_2 is less than h the effect of the wind should be considered; otherwise it should not. In this case, h_2 is greater than h , so h_2 will not be considered.

Taking moments about A we have for equilibrium of the car on the axle:

$$P_1 l = \frac{Wl}{2} - Hh_1, \text{ or } P_1 = \frac{W}{2} - \frac{Hh_1}{l} \dots (7)$$

$$\text{and, } P_2 = W - P_1, \text{ or } \frac{W}{2} + \frac{Hh_1}{l} \dots (8)$$

Also taking moments about R_1 , we have for equilibrium of the car on the rails:

$$R_1 m = \frac{W}{2} (m - b + b_1) - Hh \text{ or } R_1 = \frac{W}{2m} (m - b + b_1) - \frac{Hh}{m} \dots (9)$$

Now $R_1 = W - R_2$; but from Fig. 1 we see that R_1 and H are maximum when $R_2 = 0$; hence

$$R_1 = W \dots (10)$$

and by equation (9)

$$\frac{Hh}{m} = \frac{W}{2m} (m - b + b_1) \text{ or, } H = \frac{W}{2h} (m - b + b_1) \dots (11)$$

Now let x denote any distance from A along the axle; then we have for the moment M at any point from A to E , where x is less than f :

$$M = P_1 x, \text{ or from (8) } M = \left\{ \frac{W}{2} + \frac{Hh_1}{l} \right\} x \dots (12)$$

From E to B , x is greater than f , but is less than $(l - f)$; therefore

$$M = P_1 x + Hh_2 - R_2 (x - b_1) \dots (13)$$

Or, reducing from equations (8) and (10) in (13),

$$M = \left\{ \frac{W}{2} + \frac{Hh_1}{l} \right\} x + Hh_2 - W (x - b) \dots (14)$$

These formulas hold good regardless of whether f is greater or less than b .

Lay off on E , Fig. 1, the distance $E d = M$ by formula (12), to any scale; also lay off on E , the distance $E d_2 = M$ by formula (14), to the same scale. Draw Ad , dd_2 , and $d_2 B$. The abrupt jump at E is due to neglecting the length of the wheel hub from D_1 to D_2 . Connecting $d_1 d_2$ at the intersection of the bending moment diagram with verticals through $D_1 D_2$ we obtain a graphic representation of the moments acting at any point on the axle, from which we can find the diameters for the corresponding points on the axle by the well-known formula

$$d = \sqrt[3]{\frac{M}{.0982 S}} \dots (15)$$

In which d = diameter of axle in inches,

M = moment in inch-pounds,

S = fibre stress in pounds per square inch. According to Wohler's experiments upon the effect of repeated stresses in small bars 22,000 lb. is safe for axle steel. (Reference, Goodman; Mechanics Applied to Engineering; 1911, p. 637; also Master Car Builders' Proceedings, 1896.)

By scaling the vertical distance at any point on AB we can obtain the bending moment, direct, at that point, and by substituting the value of S in formula (15) we have for the diameter d at any point on the axle from E to E_1 .

$$d = .07738 \sqrt[3]{M} \dots (16)$$

The diameter of the axle in the wheel hub from D_1 to D

should correspond to the moment at D_2 .

Formula (16) is applicable to all portions of the axle for strength, but in the case of journals running at considerable velocity, the freedom from liability to heat is at least as important as strength and a different method of calculation must be resorted to. Experience seems to indicate that for maximum static load a pressure of about 330 lb. per sq. in. of projected area on the journals is as high as should be allowed; the writer finds that in the limit of diameters of the M. C. B. axles, this pressure corresponds to an average of about 7,200 lb. per sq. in. stress in flexure. In obtaining these values for application to axles for passenger service, the M. C. B. Association standard axle loads, which are for freight service, have been reduced 10 per cent. (Reference, A. S. M. E., Trans., 1913, Vol. 35, p. 38.) Applying these values to the journals, we have for the diameter of the journals for strength, by formula (15):

$$M = .0982 d^3 S, \text{ or } \frac{Pk}{2} = .0982 d^3 S, \dots (17)$$

$$\text{or } d = \sqrt[3]{\frac{Pk}{2 \times .0982 S d}} = .0266 \sqrt[3]{\frac{Pk}{d}} \dots (17a)$$

And for bearing surface,

$$p = \frac{P}{kd} \text{ or } P = pkl \dots (18)$$

In which P = maximum static load on the journal,

k = length of the journal,

d = diameter of the journal,

S = 7,200 lb. per sq. in. stress in flexure for maximum static load,

p = 330 lb. pressure per sq. in. of projected area on the journal,

Now from equation (17)

$$P = \frac{2 \times .0982 \times 7200 d^3}{k} = \frac{1414 d^3}{k}$$

And from equation (18)

$$P = 330 kd. \text{ Hence, } \frac{1414}{k} =$$

$$330 kd, \text{ or } 1414 d^2 = 330 k^2; \text{ and } \frac{k}{d} = \sqrt{\frac{1414}{330}} = 2.07.$$

Substituting this value of $\frac{k}{d}$ in (17a) we obtain after reduction

$$d = .0383 \sqrt[3]{P} \dots (19)$$

And from equation (18):

$$\frac{P}{k} = \frac{P}{330 d} \dots (20)$$

For an example, consider Fig. 1. Given the values l , m and h_2 , allowance for journal wear lengthwise having been decided on and the distance between the center lines of the wheel hubs being known, required the limit for the diameter of the axle, the maximum static load per axle being 31,000 lb.

The distance which the center line of car is to one side of the center of the track equals the amount of journal wear lengthwise + the clearance between the wheel flange and the rail, in this case 1 in.; the height h of the center of gravity of the car is determined and an allowance of 26 per cent for vertical oscillation is made. In this case $h = 65$ in., $m = 59.5$ in., $b = 9.25$ in., $b_1 = 7.25$ in. and $f = 10.1875$ in. The length of the hub from D_1 to D_2 7 in., $h_2 = 18$ in., $h_1 = (h - h_2) = (65 - 18) = 47$ in., and $W = 31000 \div 26 \text{ per cent} = (31000 \times 1.26) = 39060$ lb.

From (12) we have for M , from A to E ,

$$M = \left(\frac{W}{2} + \frac{H h_1}{l} \right) x, \text{ from (11) } H = \frac{W}{2h} (m - b + b_1)$$

$$\text{Then } H = \frac{39060}{2 \times 65} (59.5 - 9.25 + 7.25) = 17277 \text{ lb.}$$

For M at E , $x = 10.1875$ in. Then

$$M = \left(\frac{39060}{2} + \frac{17277 \times 47}{76} \right) 10.1875 = 308,000 \text{ in.-lb.}$$

and from (14) we have for M , at E ,

$$M = \left(\frac{W}{2} \sqrt{\frac{Hhr}{I}} \right) x + Hh_2 - W(x - b);$$

$$M = 308000 + (17277 \times 18) - 39060(10.1875 - 9.25) = 582,000 \text{ in.-lb.}$$

M , at $D_2 = 550,200$ in lb. by scale.

Then for d at D_2 by formula (16):

$$d = .07738 \sqrt[3]{550200} = 6.341 \text{ in., or } 6 \frac{5}{16} \text{ in. to the nearest sixteenth.}$$

By the same method compute the diameter at any number of points as 1, 2, 3, etc., between D_2 and the center of the axle; M at 9 = 350,000 in. lb by scale, $1\frac{1}{2}$ in. from the center of the axle, and the corresponding diameter; $d = .07738$

$$\sqrt[3]{350,000} = 5.455 \text{ in., or } 5 \frac{7}{16} \text{ in.}$$

For the journal, compute the diameter by formula (19):

$$d = .0383 \sqrt[3]{P}; P = \frac{31,000}{2} = 15,500 \text{ lb., maximum static load:}$$

$$\text{hence, } d = .0383 \sqrt[3]{15,500} = 4.77 \text{ in. as a limit.}$$

And for the length k of the journal formula (20) should be used:

$$k = \frac{P}{330 d} = \frac{15,500}{330 \times 4.77} = 9.85 \text{ in.}$$

From these calculations it is evident that a $5\frac{1}{4}$ in. by 10 in. journal should be used.

In these calculations no account was taken of the effect of brake shoe loads on the bending of the axle, as the height of the center of gravity of the car above the rail will give the maximum condition of loading the axle, which probably would never be equalled in service, except in the case of wrecks. The possibility of reaching the critical speed on curves, as well as for all the forces to act simultaneously, is remote; therefore this method of calculation may be considered safe. The clasp

journal bearing. The couple will give a bending moment to the axle in much the same manner as that produced by the brake shoe loads. This moment, however, will be in a direction perpendicular to the moment produced by the vertical loading, the resultant moment being M_r :

in which M is as before, and $M_r = \sqrt{M^2 + M_1^2}$ is the moment caused by the couple.

In addition to the combined vertical and horizontal bending there is also torsion in the axle, produced by the friction of unequal wheel load on the rail. It was shown by Fig. 1 that $R_1 = W$, and $R_2 = 0$. Now in the case of a wheel sliding, the friction force at the rail tending to rotate the wheel at R_1 is much greater than that which the brake shoe on the same wheel can resist. The wheel would actually turn had it not been for the brake shoe on the wheel at R_2 ; the result is torsion in the axle between the wheels. For motor truck axles the effect of the weight of the motor and motor traction, is to be added or deducted, as the case may be, from the moment found by formulas (12) and (14).

The term "wheel sliding" is here used for the sake of clearness only; it should be understood that retardation at the rail gives a bending moment to the axle even though no wheel skidding actually takes place.

The speed of a train on curves is limited by the stability of the cars on the rail and knowing the actual average height of the center of gravity of cars in passenger service, the design of axles, if made to correspond, will increase the permissible speed of trains on a given degree of curves, without encroaching on the safety of passengers. In steam service, this point involves, also, the stability on rails of the locomotive, which will, no doubt, continue to keep pace in this regard with the requirements of modern steel cars.

TOWEL RECEPTACLE FOR SLEEPING CARS

When towels are placed in the overhead racks ordinarily used in the toilet rooms of sleeping cars they are likely to

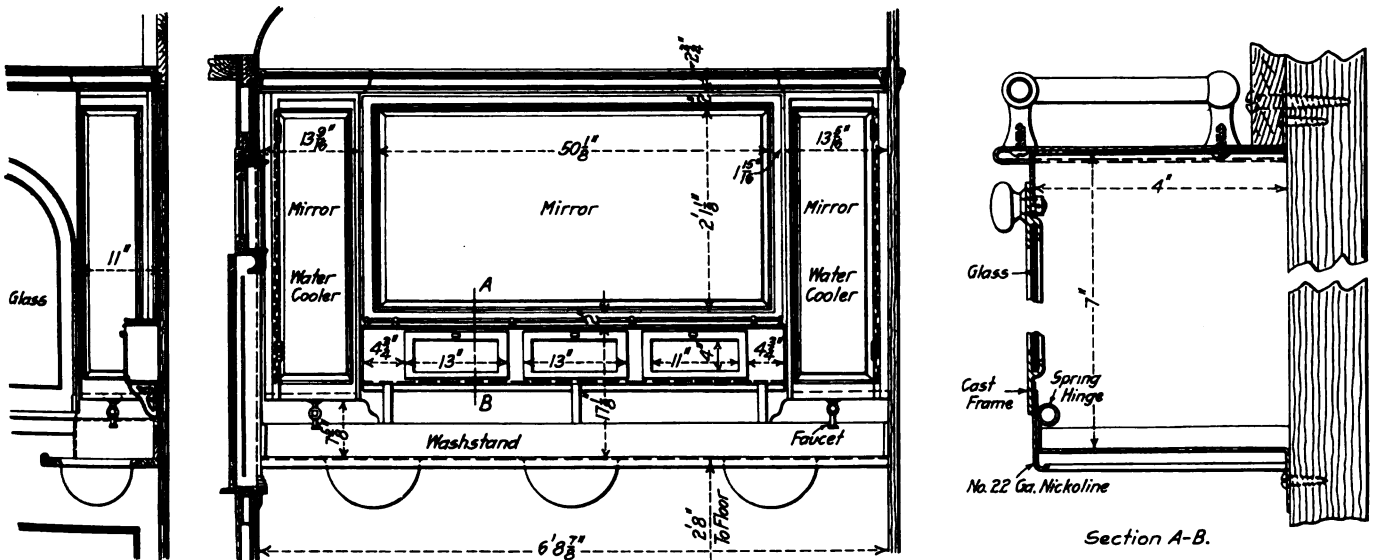

Closed Receptacle for Clean Towels in Sleeping Cars

type of brake is rapidly coming into use, which does away with the unbalanced loads on the wheel, and consequently the effect of the brake shoe loads on the bending of the axle; but unfortunately, the effect of retardation at the rail on the bending of the axle cannot be done away with. Whenever such wheel sliding occurs the frictional force tending to rotate the wheel is at the rail, having for its reaction an opposite force at the

collect more or less dust and become saturated with the odor of coal smoke. In order to avoid this, the Canadian Northern is using in its sleeping cars a closed receptacle for towels, as shown in the engraving. This is of metal construction, with glass doors in front, and is placed directly over the wash basin in the toilet rooms so as to be most convenient for passengers. The doors are provided with spring hinges so

that when they are released they will close automatically.

This towel cupboard was developed in the office of A. L. Graburn, mechanical engineer of the Canadian Northern, Toronto, Ont.

NORFOLK & WESTERN HUMIDITY-CONTROLLED DRY KILN

BY W. H. LEWIS

Superintendent Motive Power, Norfolk & Western, Roanoke, Va.

A dry kiln has been recently put in operation at the Roanoke shops of the Norfolk & Western, embodying features worked out in recent government investigations into the principles of the kiln drying of lumber. The kiln represents the direct results of the experiments of the United States forest products laboratory at Madison, Wis., the staff of this laboratory acting with the mechanical department of the Norfolk & Western in designing the kiln and its equipment.

The general principles of drying are based on what is known as the humidity-control system. It was found by the Forest Products Laboratory that the maximum rate at which moisture should be removed from the surface of lumber at any temperature is not greater than that at which it will be drawn through the fibres of the wood to the surface. The only practical way of controlling such evaporative speed is by controlling the humidity of the current of air passing over and through the lumber; hence the term "humidity-control," as applied to this kiln.

The kiln is unique in that it has no stack and no regular air inlets or outlets. The same heated air is used over and over and the moisture is removed from the air by means of a spray

or spray chambers at either side and with a heating chamber immediately under the drying chamber. The air passes over a bank of steam pipes which are located just under the loads of lumber. The heated air rises and passes through the stacked lumber to the top of the kiln. Along the top of the air legs are spray nozzles which by means of a fine mist of spray chill the air at the top of the kiln, causing it to drop by gravity down the air legs to the bottom of the kiln, where it again comes in contact with the heated steam pipes, thus performing continuous cycles. As the heated air passes through the stacks of lumber the moisture from the lumber is taken up by the air and when this air is chilled at the top of the air legs the excess moisture is precipitated and mingles with the water from the spray nozzles.

Thermostats are provided for regulating the amount of steam to the steam pipes, by which means the temperature of the drying chamber is controlled, and further means are provided for controlling the temperature of the spray water, by which means the temperature and humidity of the air before it reaches the steam pipes are controlled. The spray water is circulated by means of a suitable pump, so that this water is used over and over, an overflow being provided so that excess water will drain off to the sewer.

The kiln is susceptible of very delicate control, and by controlling the humidity of the drying air the speed of drying may be regulated to a nicety. By this means the most rapid consistent rate of drying may be attained without injuring the lumber.

In connection with this kiln there has been provided a dry lumber storage building so that the kiln itself may be of smaller dimensions and kept in continuous use. The kiln is built at one end of the storage building and a transfer car runs on a suitable



Front View of the Norfolk & Western Dry Kiln

of water which lowers the temperature of the air and causes precipitation of the moisture, the same as natural precipitation of rain in external air; thus the only discharge from the kiln is a small stream of water.

The kiln consists generally of a drying chamber with air legs

track along the front of the buildings. The lumber or kiln cars run into either the kiln or the storage building from the transfer car. The location is convenient to the planing mill.

Lengthwise piling of the lumber is used in the kiln, and the kiln cars are of steel and not of the customary knockdown type.

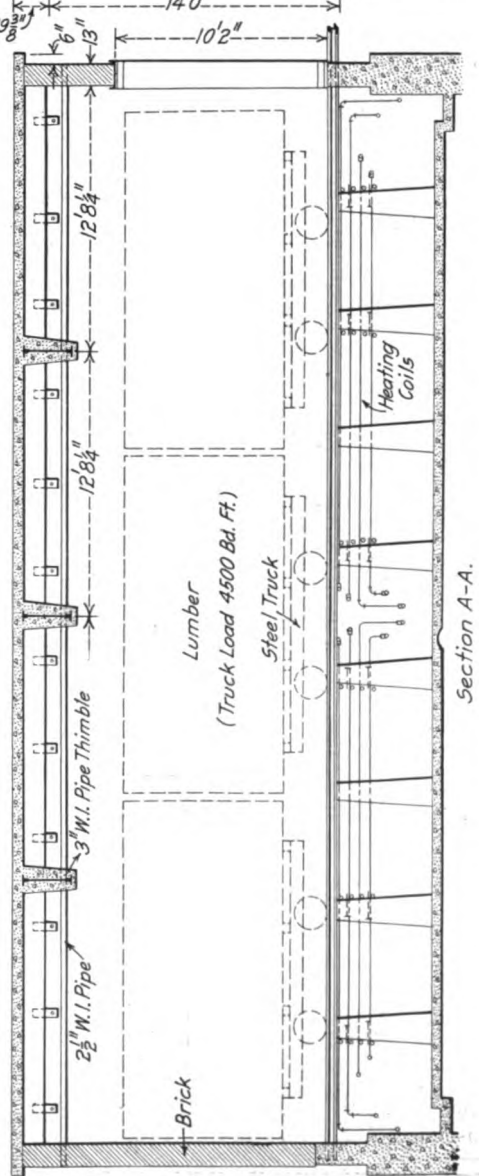
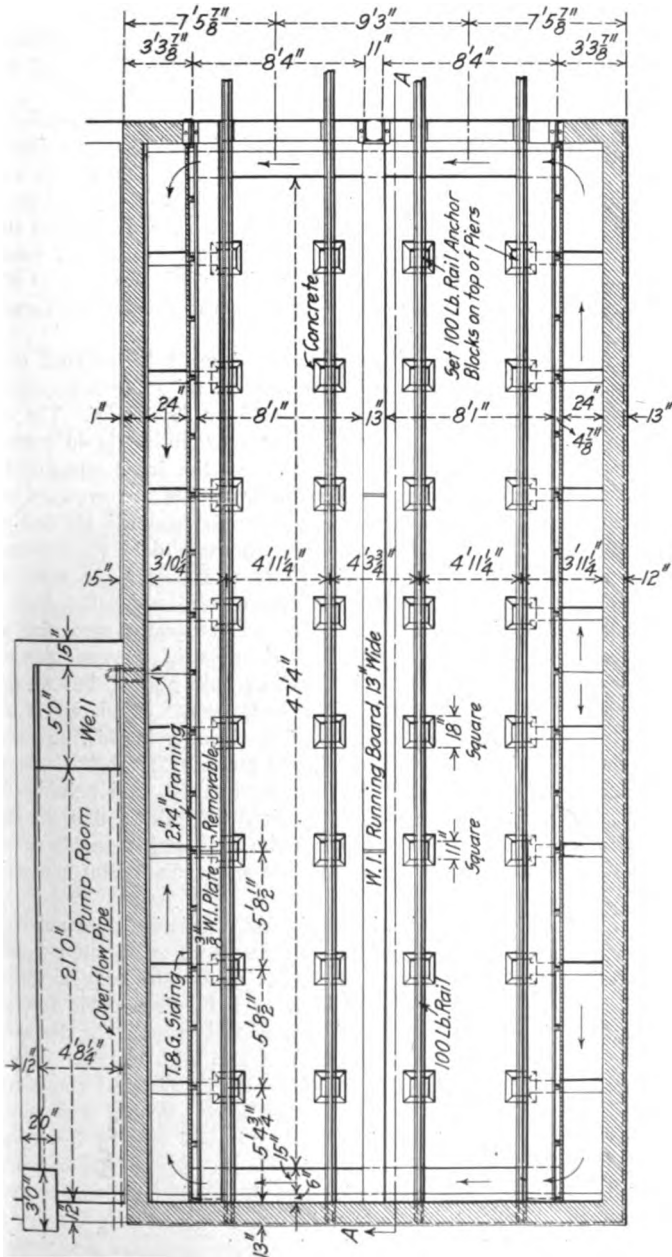
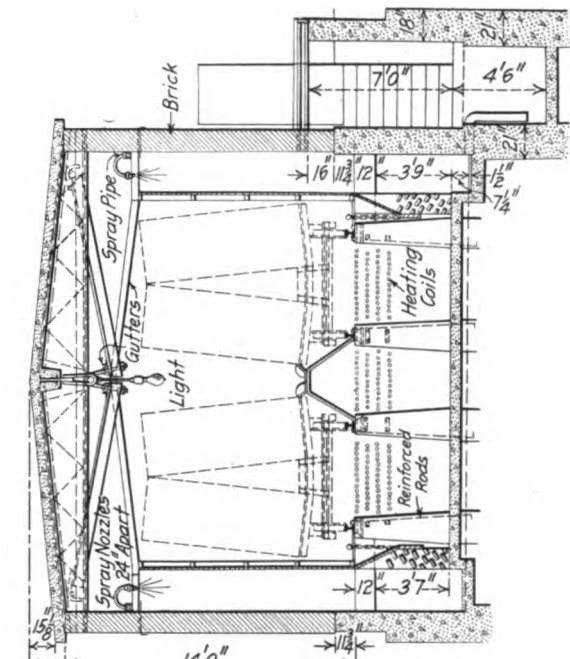
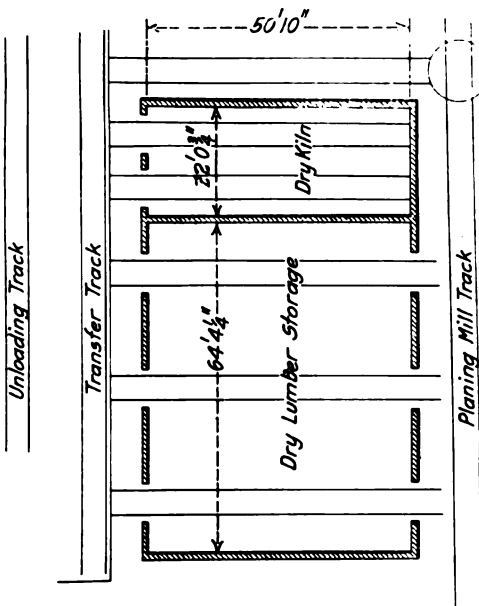

Details of Construction of the Norfolk & Western Dry Kiln

Section A-A.

A peculiar method of piling the lumber on the car is used, as shown in the illustrations. A tapered central channel is formed for the upward passage of the air, and the strips between the layers of lumber form slightly upward inclined air passages. By this means the current of air passes uniformly through the entire stack of lumber, and uniformity of drying is obtained.

The clearance dimensions of the drying chamber are as follows: Length, 50 ft. 10 in.; width, 17 ft. 3 in.; height, 10 ft. 2 in. The kiln holds six kiln cars of lumber, the capacity being



Interior of Humidity Controlled Dry Kiln

approximately 27,000 board feet of 1-in. material. It is supplied with approximately 3,300 sq. ft. of heating surface. The building is of brick laid in cement mortar; the foundations and pipe chamber are of concrete, while the roof is of cinder concrete.

This kiln has been in successful operation drying all kinds of lumber for some time and fully meets the expectations of the designers. A number of patents on the principles involved have been issued to Harry D. Tiemann, of the Forest Products Laboratory, all of which have been dedicated to the public.

THE VENTILATION OF SLEEPING CARS*

BY THOMAS R. CROWDER, M.D.

Director of the Sanitation Department of the Pullman Company

Perhaps the time has not yet come when we can say that fresh air is thoroughly understood. But we can certainly say with safety that popular conceptions concerning it are very erroneous. It is still commonly held that out-breathed air contains a volatile poison, and on this erroneous assumption have been developed the theories which have controlled the practice of ventilation almost up to the present time. There can of course be no doubt that the air confined in crowded places may become harmful through changes brought about by the people using it, and that it needs to be frequently renewed. The necessity for ventilation is beyond question, but does not arise from a poisoning of the air by the products of respiration.

*Portion of a paper presented before the annual meeting of the Society of Heating and Ventilating Engineers, Jan. 1915.

The air which surrounds the body has two principal functions: a chemical and a physical. It oxygenates the blood and it removes the body heat. For the performance of its chemical function it must contain a sufficient amount of oxygen to keep the hemoglobin saturated and be free from poisonous gases; for the performance of its physical function it must be cool enough to absorb the heat of the body, dry enough to take up moisture from the skin, and have motion enough to carry away the aerial envelope to which this heat and moisture are transmitted. If the air of the room is not renewed its oxygen is gradually consumed and it becomes laden with heat and moisture from the bodies of the occupants. In this way it may finally become unable to perform either of its principal functions. A constant supply of fresh air is therefore necessary. But careful experiment has demonstrated that under all ordinary circumstances the fault develops on the physical side so far in advance of the chemical that the latter may be practically left out of consideration. Relatively small amounts of fresh air will always supply the chemical needs of the body; large amounts may be necessary to supply the physical demands. Granted that the small amount of air necessary for the demands of respiration is supplied, the control of its physical properties becomes the great problem of ventilation; and of these physical properties temperature is vastly the most important. The success of ventilation depends far more on supplying conditions suited to the outside of the body than to the inside of the lungs.

But if the accumulated evidence of physiological studies has taken from us the old basis of chemical purity as a guide to ventilation standards, it has at the same time pointed the way to a new and more logical basis existing in the physical properties of the air. It has demonstrated that the discomfort and physiological disturbance experienced in badly ventilated rooms is due to the heat, the humidity and the windlessness of the air which render it incapable of cooling the skin at the normal and necessary rate.

An ordinary adult will produce—and must be relieved of—enough heat in the course of an hour to raise the temperature of a thousand cubic feet of air by 15 or 20 deg. F. The air with which the body is either directly or indirectly in contact must take away this heat. Herein lies the basic equation of the ventilator's problem. When many people are crowded together in a small space they very soon overheat the air, and its depressing effect is added to by its stillness and by the moisture exhaled with the breath. More air and cooler air must be supplied; fresh air becomes an imperative need. But here I would emphasize that the quality we generally recognize as "freshness" does not depend on richness in oxygen, nor on the absence of carbon-dioxide and organic poison, but on the ability of the air to remove the body heat. Fresh air is air that will cool the body more rapidly. Failing in this, no property, either physical or chemical, will make it "fresh." Coolness of the air is more important than its content, and agitation is of greater significance than its purity. It follows that the impulsion of hot air into a room is the most objectionable of all systems of ventilation, while cool air and radiant heat approach the ideal.

But changing our scientific basis for ventilation does not necessarily mean that we must entirely desert all quantitative standards in actual practice. We must not expect the body to transmit its hundred calories per hour to a hundred cubic feet of air, though a hundred cubic feet may fully supply the demands of respiration. For the body at rest and with ordinary indoor clothing, there are sharp limitations to the physical conditions that will maintain the sense of well being. Within a range of temperature compatible with comfort it will require something like 2,000 cu. ft. per hour to absorb the heat of an ordinary adult, unless the heat transmitted to the air is rapidly abstracted from it. Curiously enough, this figure corresponds closely to that arrived at long ago as the air supply necessary to maintain

the requisite degree of chemical purity. The suggestion is forced upon us that the old standards were really, though not consciously, based on thermic considerations after all, for carbon-dioxide is a guide to quantitative interchange as well as to chemical purity. But on the old basis, more air was the universal remedy for ventilation troubles—more air in order to lessen respiratory contamination—and it often failed to effect a cure. On the new basis, cooler air, or dryer air, or more motion—all of which facilitate the transfer of body heat, and none of which necessitates an increased supply—are the measures indicated; and through a proper combination of these remedies relief should be obtained.

It is now seven or eight years since I began to study the ventilation of sleeping cars and to attempt a solution of the vexed question concerning the best methods for producing comfortable and hygienic conditions in them. In common with most people I then believed these cars had a very inadequate air supply. As we now understand the subject, it must be admitted that the cars were poorly ventilated, and that the air supply was sometimes small, but faulty ventilation did not usually lie with an insufficient volume of air. Other faults were much more frequent, and chief among them was artificial overheating.

When my studies were begun the almost universal plan of ventilating railway cars was to introduce fresh air by opening small windows at the top of the car which are usually referred to as deck-sashes. Sometimes large volumes would enter through these openings, sometimes little or none, and sometimes they would act as outlets only. With changes in the direction of the train or the wind these various actions would alternate. The openings being large, when they became active intakes, uncomfortable downward draughts were produced; when they ceased to act as intakes the total air supply would be much restricted and overheating would be readily brought about. The result of this plan was that ventilation was very irregular, that an adequate air supply could not be depended upon, and that comfortable or hygienic thermic limits could not be continuously maintained.

A little experimentation soon demonstrated that sufficiently large volumes of air for all the practical purposes of sleeping car ventilation will, under certain circumstances, enter the car

and a device was applied to the roof of the car which utilized the power supplied by train momentum to produce suction, thereby drawing air out through the deck-sashes formerly used as intakes.

The purpose aimed at was well achieved. The result was as contemplated. The average air supply was much increased and the flow regulated. Perfect regularity of air supply was not realized; but it is one of the fallacies of general opinion concerning ventilation that perfect regularity of air supply is desirable. It has been pointed out by Leonard Hill that one's comfort depends in a vast degree on the stimulation of a changing physical environment—that it is due to the ceaseless variation of the temperature and motion of the surrounding air. In this light irregularities of air supply and air temperature become of great importance, but they should not vary beyond the limits within which comfort lies.

The objection is sometimes raised that simple exhaust ventilation, without the provision of inlets, cannot possibly furnish to railway cars a sufficient air supply. I, too, was originally of that opinion; but so far as the requirements of sleeping cars are concerned it was a mistaken opinion, as has been amply demonstrated. The quantity may at times be quite astonishing. I have measured up to 30,000 cu. ft. per hour passing out through the ventilator duct from a small stateroom with the door and windows closed, and when, therefore, the air had to find its way in through crevices. Much of it came from the adjoining passageway, through the freeway under the door. Natural crevices are sufficient air inlets if properly utilized, and they possess a vast advantage over larger openings. The incoming jets of cold air are individually so small, and they take on such irregular motions in mixing with the stiller air within, that all the good effects of variegated temperature and motion are obtained without the disadvantages of uncomfortable cold draughts.

If a few large inlets are used and the weather is cold, the incoming air must be pre-heated. Pre-heating has its drawbacks, but it is necessary for most heavily occupied places. If sufficient crevices are available, and the occupancy is not too great, pre-heating may often be dispensed with. Few enclosures are so richly endowed with crevices as is a railway car; no

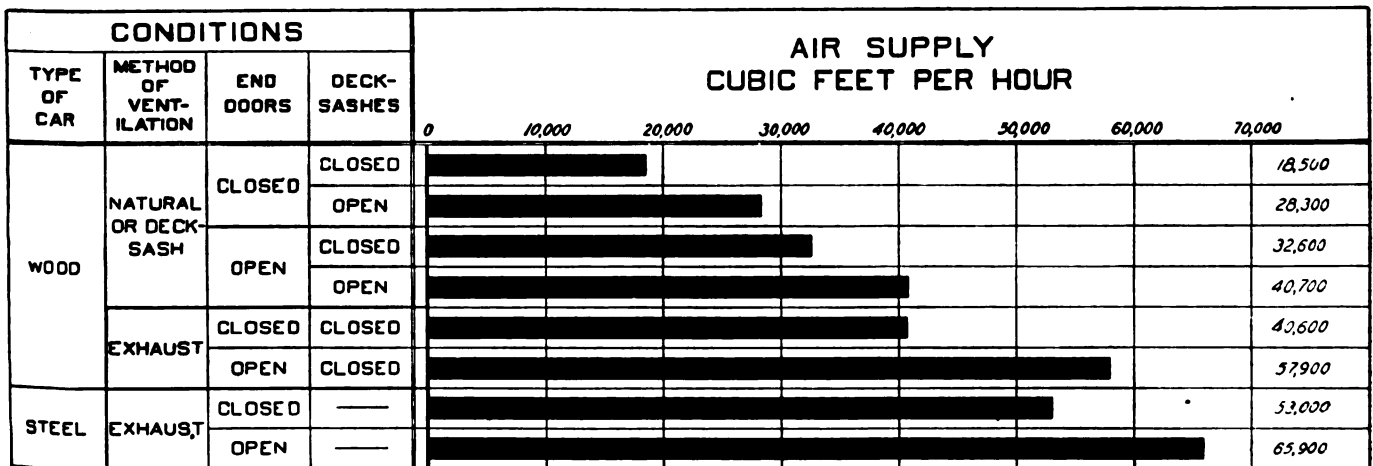

Fig. 1—Methods of Ventilating Sleeping Cars Compared*

through the several hundred feet of crevices about doors and windows. Thanks to the imperfection of the car builder's art, it has not been found possible—though much pains have been taken in trying—to build a railway car so tight but that much leakage may take place. When this occurs the air of the car remains relatively pure, heat does not accumulate, and comfort is maintained. It was therefore deemed advisable to utilize these crevices as air intakes and to attempt their regulation by providing a constant forced exhaust from the top. To this

other place is so constantly subjected to high winds, which cause crevices to let in outside air whether we will or not. In entering, these cold jets meet the warm stream flowing upward past the windows and the mixing begins at once, as it should. But whereas these crevices act irregularly, and in the main inefficiently, as air intakes when unaided, they act efficiently and with a sufficient degree of regularity when assisted by exhaust ventilators located at the top of the car.

Of course, we cannot directly measure the amount of air flowing into a car through its many crevices. But we can

*801 observations in 183 cars.

measure the outflow through the ducts of exhaust ventilators, and we know the one must equal the other when only crevices are available as inlets. We can also estimate the air interchange by determining the proportion of carbon dioxide in the inside air and counting the number of occupants concerned in producing the contamination. Both these procedures have been carried out. By the former it has been demonstrated that the ventilators now almost universally installed on Pullman cars will each discharge from the running car some 12,000 or 15,000 cu. ft. of air per hour. Six are applied to the twelve-section body of the standard car, and they all work constantly, though not at a constant rate.

But determining the outflow of air records only a minor fact. Without a study of the entrance, the distribution, and the interchange in the zone of occupancy it remains of little value. Herein lies the necessity of learning the carbon dioxide content of the air. It enables us to determine these things, and it must always be a part of any adequate study of air conditions. On it we may base also reasonably accurate estimates of total air supply; but it should be kept in mind that

cars were running in regular service at ordinary speeds and with various possibilities as to air inlets and outlets. The significant bars of the chart, representing cars where no intakes in addition to crevices were provided, are the first, fifth and seventh. Unaided by exhaust ventilators the average air supply through crevices alone was only 18,500 cu. ft. per hour; aided by exhaust ventilators the averages were 40,600 and 53,000 cu. ft. per hour for wooden and steel cars respectively. The difference between the latter two is believed to depend on the almost total absence in the steel car of crevices in its upper portion by reason of the absence of deck-sashes and a consequent absence of short-circuiting of air currents from deck-sash crevices to ventilators necessarily close at hand. There is in consequence a more constant withdrawal from below, and a more rapid changing of the air of the lower levels. The average occupancy of the cars represented in Fig. 1 was about fifteen people each, from which it follows that there was considerably more than 2,000 cu. ft. of air per hour for each occupant in the cars equipped with exhaust ventilators, while there was only about 1,200 cu. ft. per hour for each occupant in those not so equipped. Since the figures apply only to the 12-section sleeping car body, the practical maximum occupancy is about 25 people.

In Fig. 2 are shown the relative average air supplies per person, as determined by the carbon dioxide content, for the upper berth, lower berth and aisle of cars ventilated by open deck-sashes, and of wooden and steel cars ventilated by the exhaust method with only crevices as inlets. All berths were occupied by one person each, and each group of cars contained an average of about 16 people. The air supply is seen to be considerably larger with the exhaust type of ventilation; and it is sufficient to meet the physical as well as chemical demands placed upon it. Not only is the average volume of air supplied to berths increased by the exhaust method of ventilation, but the flow is more regular and is more constantly maintained.

It seems beyond question that a great improvement has been made in the ventilation of sleeping cars by the adoption of the simple exhaust method, and that the results are on the whole quite satisfactory. Carbon dioxide never rises so high—it is rarely as much as 10 parts in 10,000—as to indicate an air supply insufficient for the needs of the body; the supply of air is reasonably uniform, while the innumerable eddies caused by minute incoming streams of cold air striking the warmer air within bring about thorough mixing and good distribution without destroying the ceaseless small variation so essential to continued comfort. The possibility of overheating still remains, and must always remain with any system of car ventilation, as a matter requiring intelligent attention. But the assurance of a constant and fairly regular supply of cool air from without makes it a much less probable occurrence, while changes in car-heating plans and simple instructions to car operators concerning the significance of thermometers have also aided greatly in remedying the evil.

DISINFECTANT ARRANGEMENT FOR PASSENGER CARS

Considerable trouble has been experienced in maintaining drip disinfectant devices in working order because of the loss of the piping. The reason for this is that the connecting nipple on the base of the reservoir is turned away from the finish, thus allowing the supply pipe to project out where it is liable to damage. The only supporting medium under these conditions is a single clip immediately underneath the reservoir. The drawing shows an arrangement with the tank placed in the corner of the saloon and allowing the piping to pass close to the finish for its entire vertical length and laterally to a point directly in the rear of the hopper. It is thus possible to securely clamp the pipe for its entire length.

At the right side of the drawing is shown the arrangement

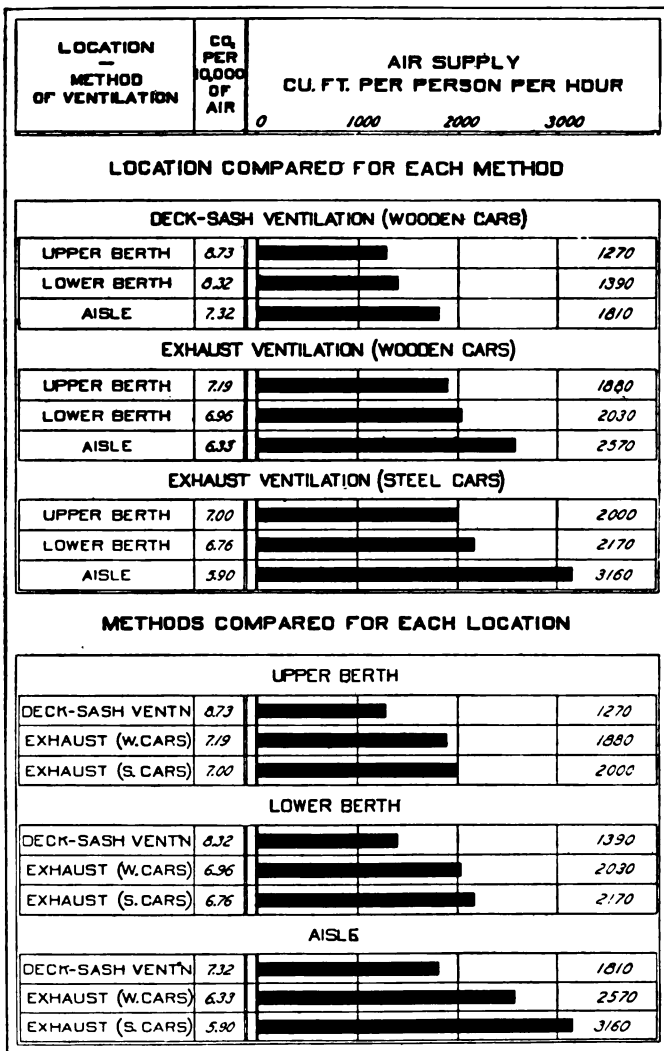

Fig. 2—Relative Ventilation of Upper Berth, Lower Berth and Aisle*

estimates so made will fall below rather than above the actual. A fairly extensive study of carbon dioxide in the air of sleeping cars has been made, the details of which have all been reported in other places. We may refer here to a few general averages only which will be recorded in the form of charts.

In Fig. 1 are represented the average air supplies, as determined from the carbon dioxide in the breathing zone, while

*2746 observations in 130 cars.

of the vapor type of disinfectant in the enclosed hoppers used in sleeping car compartments and private cars. The ventilating arrangement prevents the accumulation of odor from the disinfectant cake from flooding the room when the hopper cover is

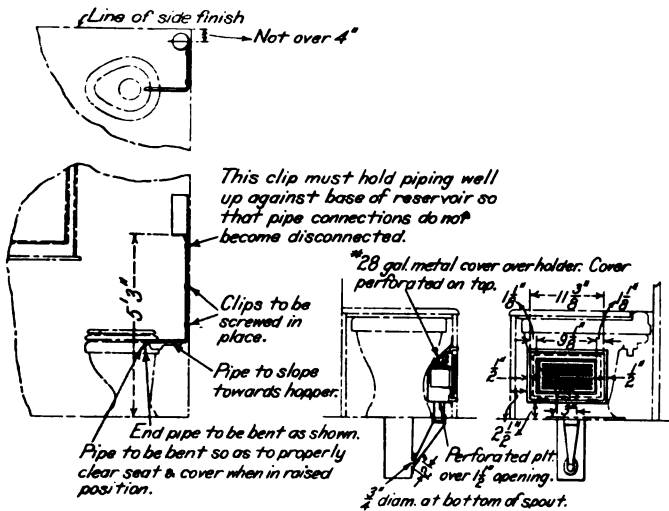

Arrangement of Disinfectant Holders in Passenger Cars

raised. The excess odor from the disinfecting cake is carried out through the funnel. This arrangement is in use on the Canadian Northern and was designed by A. L. Graburn, mechanical engineer of that road.

CAR ELECTRIC LIGHTING SYSTEMS

The following is taken from an article by E. S. McNab, inspector of electric car lighting, Canadian Pacific, appearing in the June, 1915, Railway Electrical Engineer.

The problem of lighting passenger equipment by electricity is comparatively new on this continent, although in Europe and the British Isles it has been the practice for about twenty-five years. However, the rapid increase in the number of equipments applied in North America, during the last few years, has, to a great extent, compensated for the relatively late start.

In 1911 the Canadian Pacific Railway had only 68 electric lighted cars, whereas this figure has now been increased to 380, which includes 100 per cent of the compartment sleepers and observation cars, 85 per cent of the modern sleepers and 60 per cent of the total number of diners; the remaining gas-lighted cars of these classes are being converted as the cars receive general repairs. Large increases which have been made on the Pennsylvania, New York Central, and New York, New Haven & Hartford are probably due to the tunnels by which they enter New York City, gas or oil lighted cars not being permitted to enter either of these terminals.

I will divide the methods adopted in lighting cars by electricity into three main systems, namely, the straight storage system, the head end system, and the axle system.

The equipment for the straight storage system consists of a set of storage batteries contained in battery boxes under each car, the batteries being connected to the lamps by the usual wires and controlled by a single switch or switches. This is certainly the simplest method of lighting, but when we investigate its methods of operation we get into difficulties.

In the first instance, the batteries have to be charged at each terminal, or at least after every eighteen to twenty-four hours of lighting, which necessitates the car being held in the terminal yard for a period of from six to ten hours, depending on the condition of the batteries on arrival.

It is interesting to note that at one of the New York yards

350 outlets have been installed, each outlet having a separate pair of wires back to the switchboard in the power house, No. 8 cable being the smallest size used. Power is obtained from three 250-kw. motor-generator sets, giving 110 and 220 volts. The switchboard arrangement is also considerably complicated due to the large number of individual circuits which have to be controlled.

It is interesting to note in passing that an attempt has been made to reduce the lengthy period of charge by increasing the charging rate by the use of the Wilson battery. This battery is so constructed that it can be charged at 1,000 ampere rate for a short period, but, as is apparent, this high rate involves specially heavy charging cables throughout the yards, and also special fittings on the cars. It has been adopted to a limited extent on the Erie Railroad on its suburban trains, but its non-adoption by any of the other roads indicates that its disadvantages overbalance its advantages.

The head end system, as its name implies, consists of a steam driven generator in the baggage car, located as close to the locomotive as possible. This system is in use on most of the roads running west of Chicago, and on "limited" or solid trains gives good service. The equipment consists of a 20 or 25 kw. turbo-generator located in the baggage car, driven by steam from the locomotive; a control switchboard is installed from which three main cables run overhead throughout the trains. As the turbine must necessarily be stopped during change of engines or while standing in a terminal before the locomotive is coupled up, it is therefore necessary to install a certain number of storage batteries on the train which will carry the lighting load during the above-mentioned periods.

It is the Northern Pacific practice to install 200 ampere-hour batteries on the postal car, dynamo car, standard sleepers and observation car on each train. On most of the roads using this system the baggagemen are trained to operate the electrical equipment, and after showing a certain proficiency by means of examinations, receive higher pay. I am advised by several of the electrical engineers that these men are giving satisfaction; some roads, however, still continue to employ train electricians.

The chief disadvantage of this system is the want of flexibility, and this is felt where trains have to be remarshalled at junctions and cars switched off on branch lines; this leads to the necessity of equipping a large proportion of the cars on every train with batteries, increasing the capital and maintenance costs. Another disadvantage is the high steam consumption which the turbine accounts for, and our experience in Canada points to considerable difficulties from this source during the winter months should this system ever be tried.

The axle generator system comprises a generator driven by means of a belt from the axle and a set of storage batteries which supply current to the lamps when the train is at rest. As this equipment is applied to each car it follows that it is an individual unit and can be transferred to any line in any class of service without any adjustment of the apparatus being necessary.

The design of an axle device involves the overcoming of five problems: (1) The reversal of polarity, due to the change in direction of rotation of the armature when the car reverses the direction in which it runs; (2) the maintenance of a constant output in watts or horsepower, irrespective of the speed of the train after the generator reaches its maximum, which is 22 to 25 miles per hour; (3) the lamp voltage must be held constant at the normal voltage, which is 30 in the United States, and generally 24 in Canada, while the generator is running at a voltage of 40 in the United States and 30 in Canada; (4) the batteries must receive a sufficient charge to replenish the loss of current consumed at terminal stops, but at the same time must not be overcharged; (5) an automatic arrangement must connect the generator to the batteries when

the speed of the train is such that the generator voltage is equal to the battery voltage, and disconnect them when the speed falls below that point. To meet the foregoing conditions there are about a dozen patent systems in use in Europe. None of these have ever been adopted in this country, with the exception of the Stone System, which is extensively used in Canada. In the United States there are five principal systems, namely, the Safety, Gould, Consolidated, United States, and the E. S. B.

STENCILING GAGE FOR FREIGHT CARS

BY W. F. JAMES

Foreman Painter, Atlantic Coast Line, Rocky Mount, N. C.

The accompanying illustration shows a very simple, inexpensive wooden stencil gage. The lower end of this gage is provided with an offset point which bears on the under surface of

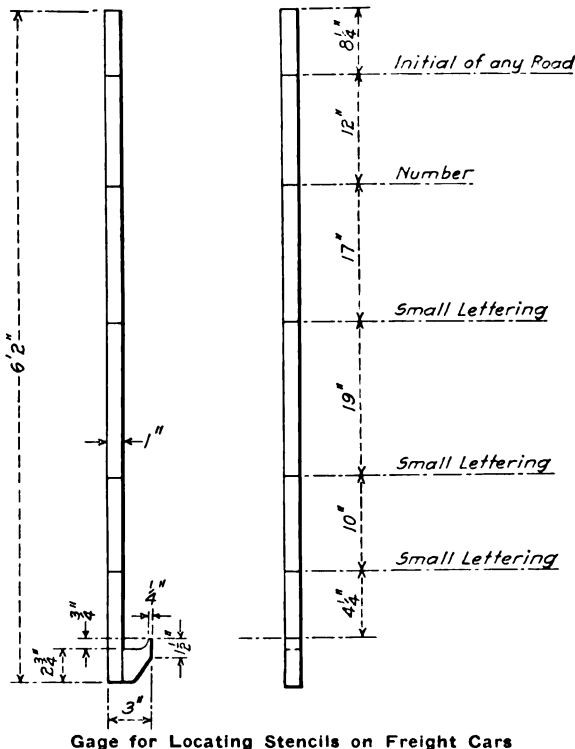

Gage for Locating Stencils on Freight Cars

the side sill, providing a much more accurate method of gaging the lettering than by using the bottom of the sheathing or siding. Much better results have been obtained with this device than with any other so far used.

UNIFORMITY IN CAR INSPECTION*

BY M. MAREA

General Superintendent, St. Louis, Troy & Eastern, St. Louis, Mo.

I will take up this question in three sections: (1) Interchange points, (2) Delays to cars, and (3) Need for greater co-operation between car departments throughout the country.

The inspection of cars at interchange points is of more than ordinary interest. It is the problem which confronts inspectors and car foremen today and which requires men of more than ordinary ability to solve. A good car inspector is one of the most valuable assets that a car foreman can have, and a car foreman is the most valuable asset that any railroad can have, if he is capable of passing judgment on the cars that are to run upon his rails. The latter is a question which may not seem important, but it is of vital importance from an operating standpoint.

*From a paper read before the Car Foremen's Association of St. Louis.

Not only is the inspector responsible for the condition of the cars, but he makes his company responsible to the shipper for the delay to the freight that is contained in the car which has been shipped. This reverts back to the traffic department, which has spent many hours and probably days of hard work to secure the shipment. Consequently, the inspector must be a man of more than ordinary intelligence, must use good judgment and not hold a car for repairs if it can safely be moved forward. I have found that the source of the greatest trouble between car inspectors and car foremen lies in trying to "get even with the other fellow." This is decidedly wrong. An inspector must be fair and honest with his own company and also with his delivering line, and not shop for repairs any car which in his judgment can go forward. Of course some mistakes will be made.

Too many cars are being delayed by inspectors because certain visible defects exist which apparently justify them in sending the cars to the transfer track. This is frequently because the car department has been allowed only a certain amount of money and the foreman in charge feels that he has not money enough to make the repairs; the car is therefore marked for the transfer track and a claim made for defects. If the claim is cut by the chief interchange inspector, the contents are nevertheless transferred and the car is returned to the delivering line. The delivering line, in 99 cases out of 100, loads the car without repairs being made and it starts forth in a different direction and carries its contents through interchange points safely and without complaints being received from three or four of the interchange points through which it passes.

Now if the car department were charged with the cost of the transfer, the per diem of the load and empty, as well as the damage to the contents, the transfers of to-day would, I dare say, decrease 75 per cent. because of placing the responsibility where it actually belongs. You may wonder why I make such a broad assertion; but the car department is wholly responsible to the operating and traffic departments for the furnishing of equipment that is in safe and serviceable condition to move whatever commodity it is desired to place therein. If the car gets in bad order through unfair usage the car department is not responsible.

The car departments throughout the country are not working close enough together and are not using what may be called a broad and liberal interpretation of the M. C. B. rules of interchange.

ELECTRIC IRON FURNACE.—Pig iron production by means of the electric furnace is carried on at Tinfos, Norway. Coke is used as the reducing material and the ore carries 44 to 47 per cent iron. The power of the furnace is from 1,200 to 1,400 kilowatts. There are four furnaces at Tinfos, three being usually in operation, while one is held in reserve. The output is about nine tons per furnace per day.—*The Engineer.*

NEW NITROGEN FACTORY IN NORWAY.—At the Bjølva waterfall, Norway, a new factory is to be erected for the manufacture of sulphate of ammonia and cyanamide. Arrangements have already been made to dispose of the output of the latter production for a period of five years. The annual output of sulphate of ammonia will be about 6,000 tons. The matter is being supervised by a committee of four experts, who are at present in Sweden in order to study the new method of manufacture.—*Engineering.*

SUMMER SCHOOL OF SCIENTIFIC MANAGEMENT.—The Pennsylvania State College, State College, Pa., conducted a summer school of scientific management during the two weeks beginning August 9. This summer session was planned for the accommodation of works managers, superintendents, heads of cost, stores, purchasing, planning and productive departments, and members of such departments. The time was restricted to two weeks to meet the needs of employees whose vacation period was limited to that time.

SHOP PRACTICE

REINFORCED ASBESTOS GASKETS FOR ALL PUMP CYLINDER HEADS

BY J. A. JESSON

A method of reinforcing asbestos fibre gaskets for use on 9½ in. air pumps, that renders them immune to blow outs or leakage around the steam ports so common with copper gaskets is shown in the drawing. A piece of ordinary wire gauze such as is used in passenger car ventilators is wrapped around one side of the gasket with its ends extending as far as the edges of the steam

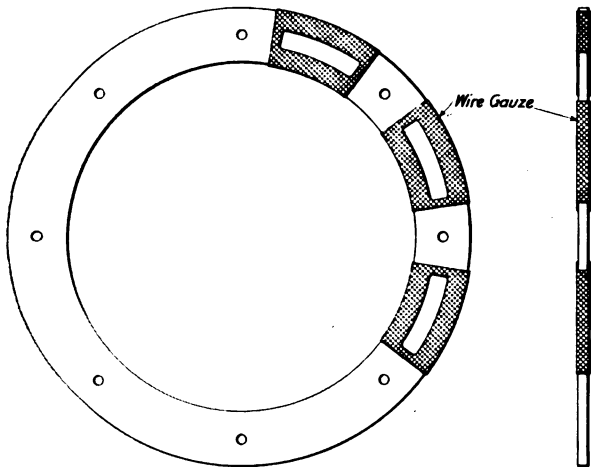

Reinforced Asbestos Fibre Gasket for Air Pumps

port on the opposite side; that part of the gauze which crosses the port is then cut away. Tightening down the cylinder head embeds the gauze in the fibre and strengthens the gasket at this point.

In order that the gasket may be used over and over again it is necessary that it stick only to the head. This can be accomplished by liberally coating the cylinder flange with dry flake graphite and applying none to the cylinder head. The advantage of this method lies in the fact that a copper gasket is unfit for use again at this point and is often scrapped. There is hardly any difference in the first cost of the two kinds of gaskets.

AN ELECTRIC PROCESS FOR SAFE-ENDING TUBES

BY L. R. POMEROY

The Norfolk & Western is using an electric welding process for safe-ending tubes at its Roanoke, Va., shop. The arrangement of the machine and the grouping of the equipment is shown in the engravings.

In Fig. 1, Clamp No. 1 is fixed to a table, while Clamp No. 2 is designed for horizontal movement by means of a toggle operated by a lever. By means of this the safe end, *A*, is pressed hard against the tube *B*, so arranged that an electric circuit is made, the switch being closed by the lever, simultaneously with the contact of the safe-end *A* with the tube at *B*. The air cylinders on both clamps operate a movable jaw, gripping and firmly holding the tube and safe end. The wings of the clamps are cored out and provided with water circulation, to rapidly dissipate any heat caused by the welding heat.

The welder, Man No. 1, Fig. 2, operates the electric welding machine, the helper, Man No. 2, cuts off the scored ends of the

tubes and places them in Rack No. 2. In operating the machine the welder places the safe end in Clamp No. 2 and at the same time the helper places the cut off end of the tube to be welded in Clamp No. 1. The welder then forces the safe-end against the tube by means of the lever which operates the toggle, and when the contact is made the electric circuit is closed, the contact surfaces coming up to a welding heat almost instantly. When complete the helper removes the welded tube to the roller, and while the tube is being rolled smooth on the outside by the rolls under spring pressure, and by the mandrel on the inside, another tube is inserted in the electric welding machine. The rolling operation seems hardly necessary, as the tube leaves

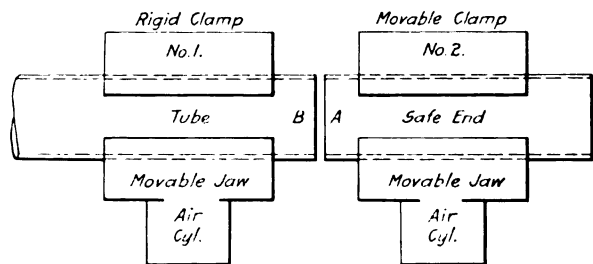

Fig. 1—Clamp for Holding Tube and Safe End

the welder in a condition fit for service, and we are told the rolling operation is simply a precautionary measure against any roughness or fins that may possibly arise. The final result is a tube so smooth and regular that the line of the weld is hardly visible to the eye and to all appearances the tubes so safe ended can hardly be distinguished, save perhaps by color, from new ones. The tubes and safe-ends are not scarfed; the operation therefore is what is called butt welding, in contradistinction to scarf welding, when the tube is belled out and the safe end scarfed and stuck in the belled mouth of the tube.

The complete operation of welding and rolling, as timed by stop watch, occupied just 20 seconds per tube, or 3 tubes per minute, which is equal to 180 per hour—or, allowing for con-

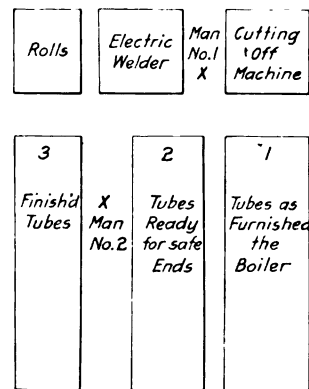

Fig. 2—Grouping of the Equipment

tingencies, say 100 per hour. At this rate, one machine and two men would weld enough tubes per day to complete two boilers, or as fast as the most modern type of cleaning machine can prepare the tubes.

The electric welding machine is operated by alternating current through a transformer, the primary voltage of which is 220 volts, and the ratio of the transformer reduction about 44 to 1. The transformer is rated at 35 kw. With electric current at 5 cents per kw.-hour the cost per tube, rating the welder

and helper at 50 cents and 35 cents per hour respectively, amounts to less than 1½ cents per tube at the rate timed, i.e., 20 seconds per tube, assuming the full capacity of the transformer; the average current used is very much lower. This fact and the cost for current used insures a liberal overhead for power, as it is understood that power is produced at less than 2 cents per kw.-hour at the switchboard.

The welding machine is made by the National Electric Welding Company, Warren, Ohio.

TESTING DEVICES FOR AIR BRAKES

At the recent Air Brake Association convention, Frank Sherman, air brake instructor of the Louisville & Nashville, spoke of a device that is used for testing air brakes in the repair yard or "rip" tracks. Ordinarily at these places the air pressure

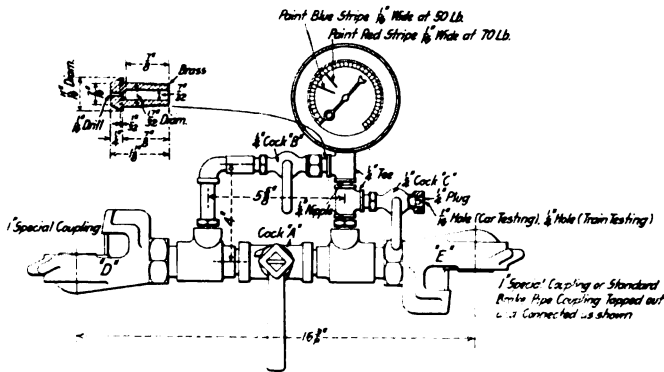

Fig. 1—Arrangement for Testing Air Brakes with Shop Line Pressure

is from 90 to 100 lb., and if pressure of this magnitude is used for testing, it may be found that cars that test out under it will not respond to the action of the engineer's brake valve under the ordinary train line pressure.

The device referred to is shown in the accompanying illustration,

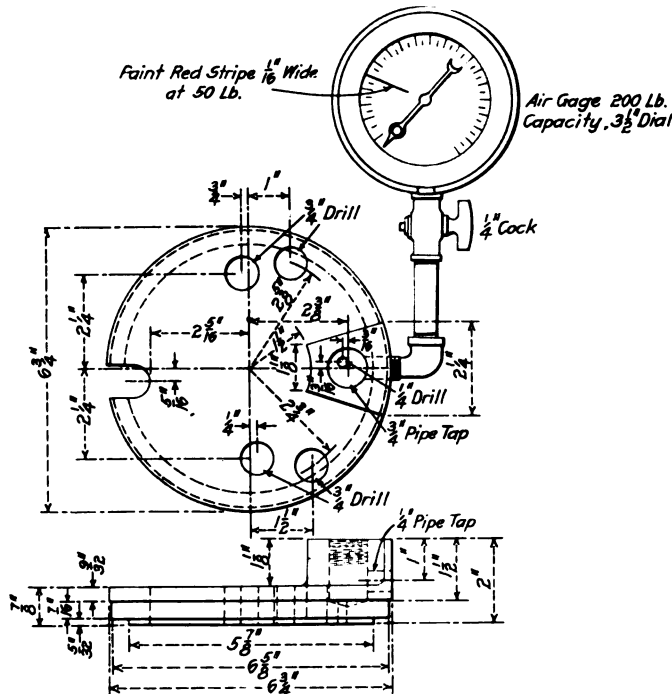

Fig. 2—Device for Testing Brake Cylinders After Repairing

tion, Fig. 1. The coupling *D* is connected to the air supply line and the coupling *E* to the car to be tested, the other end of the car, of course, being closed. Air is admitted to the train line

under the car by opening the cock *A*. This will record the pressure on the gage shown, the cars to be charged to 70 lb. pressure and then the cock *A* closed. The brake pipe is then watched for leakage. The brakes are applied by opening the cock *C*, which allows the air to escape from the train line through a 1/16 in. opening as indicated. The pressure in the train line is reduced 20 lb., which should be sufficient to apply the brakes. The piston travel, which should not be less than 5 in. or more than 6 in., should also be noted. The brakes are released by opening the by-pass cock *B*, which is also provided with a 1/16 in. choke plug to provide a gradual rise of pressure in the train line similar to that received in service. The brake failing to release will indicate worn bushings or defecting packing rings in the triple valve piston. The device is of simple construction and is readily understood from the drawing. Where it is used for testing trains the discharge opening of cock *C* should be provided with ¼-in. choke, instead of 1/16 in.

A device used for testing the leakage in brake cylinders that have been cleaned, oiled or repaired, is shown in Fig. 2. It is applied in place of the triple valve, the ¼-inch opening forming the connection between the brake cylinder and the gage shown in the illustration. The cylinder is charged to 50 lb. pressure, the supply cut off and the leakage noted. This leakage should not exceed 5 lb. per minute.

TURNING COMMUTATORS IN THE POWER HOUSE

BY H. L. LOUCKS

Machine Shop Foreman, Erie Railroad, Dunmore, Pa.

The device shown in the drawing is designed for use in turning and grooving commutators with the armatures in their own bearings. If this work is done in the machine shop it is necessary to remove the armature, thus disturbing what are probably good bearings, and often to work overtime in order to place the generator in service again with as little delay as possible. This procedure takes at least three or four days.

This device is designed to be attached to the journal box cap, which, as a rule, has a planed surface and requires the removal of one brush connection. When it is in place the engine is started and the armature turned with its own power.

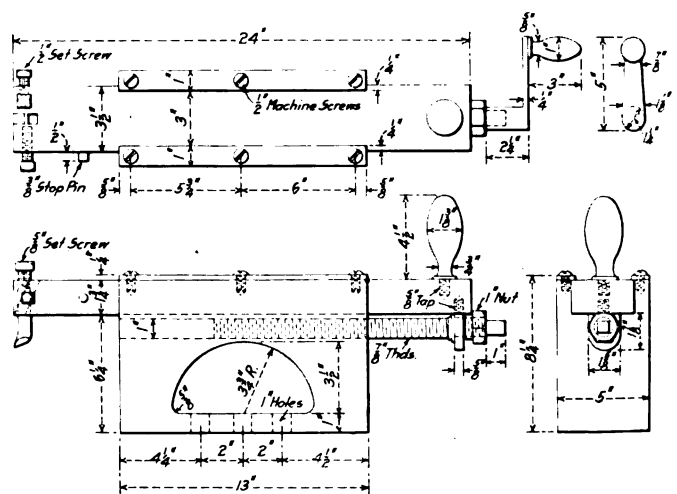

Apparatus for Turning and Grooving Commutators with Armatures in Their Own Bearings

After this operation is completed the feed screw is removed and the handle applied to the tool slide, which is then used as a shaper to cut the mica between the commutator bars. A turning and a shaping operation are thus completed in about six hours and the generator is again in condition for service without serious delay.

MASTER BLACKSMITHS' CONVENTION

Heat Treatment, Spring Making, Drop Forging, Electric Welding, Piece Work, Reclaiming Scrap, Etc.

The twenty-third annual convention of the International Railroad Master Blacksmiths' Association was held August 17-19 at the Walton Hotel, Philadelphia, Pa., T. F. Buckley, of the Delaware, Lackawanna & Western, president of the association, in the chair. The opening prayer was offered by Rev. Elmer M. Stapleton, and a short address was delivered by President Buckley. The association was welcomed to the city by Edward J. Cattel, city statistician, on behalf of the mayor. An address of welcome was also delivered by C. E. Carpenter, president of the E. F. Houghton Company, and C. E. Chambers, superintendent motive power, Central Railroad of New Jersey, spoke on the "Progress of Foremen Blacksmiths in Railroad Service."

ADDRESS BY C. E. CHAMBERS

Mr. Chambers spoke in part as follows:

No part of the railroad organization is more interesting to me than the blacksmith department; from the time I was a boy on an Illinois farm I have never ceased to be keenly interested in that work. No part of our great railroad organization has undergone more revision than the smith shop. True, many things are done nearly the same as in former years; flue welding still resembles the practice of many years back, excepting slight changes in scarfing and preparation. But spring making and repairing has been simplified and perfected by improved devices for assembling and banding, so that much of the manual labor has been reduced, and a better spring is produced. The oil, acetylene, electric and Thermit welding processes have entirely revamped some of our smith shop practices. Where once it was always necessary to remove an engine frame and take it to the smith shop for repairs, such a practice now would be almost an impossibility by reason of the extreme size and many complications of construction, which would not only greatly increase the cost of repairs, but would hold the locomotive out of service very much longer. Quite frequently we can make a weld and return to service the same, or next day, where our old system would require from 7 to 10 days, or possibly longer.

One of your subjects for consideration at this convention, that of heat treatment of metals, is deserving of careful study and consideration. Not only is heat treatment desirable for new material, but periodical annealing adds much to the life of many parts of locomotives and cars. No subject for your consideration should receive more careful attention than reclaiming of scrap. Everything must in time find its way to the scrap bin, but should not do so until it has served its last purpose. But there is a dividing line beyond which it is more economical to cast aside the old and use the new.

FLUE WELDING

E. J. Haskins (New York Central)—We maintain four hundred modern engines at the Elkhart, Ind., shops. The tube welding and swedging is handled in the blacksmith shop. We have two flue rattlers, one 23 ft. long, and one 18 ft. long, running about 15 revolutions per minute with a load of about two hundred 2-in. flues. The 2-in., 2¼-in. and 3-in. tubes are cleaned in these rattlers in from two hours to four hours' time, the variation in time depending upon the amount of scale on them. After the tubes leave the rattler they are cut off at the firebox end with a belt driven cutter, having two rollers below with a rotary beveled cutter above. They are heated and the ends belled out on a horn and safe ends applied. One man swedges and welds tubes of 2-in., 2¼-in. and 3-in. diameter. After welding the tubes are brought to the hot saw, where they are heated in an oil furnace and sawed to proper length, the operator of this saw taking his own measurements for length from the boiler. They are then

placed upright in a pit for the purpose of annealing the ends. About five men in the tube department handle from six to eight thousand flues per month of nine working hours a day.

After the flues are rattled we sometimes find them broken off at the first weld, where there are four or five welds. This is the most severe test the tubes are subjected to. We test all tubes that have more than one weld with a hydraulic testing machine at 300 lb. pressure, as we frequently find defects in the old welds. Our safe ends are made from new stock. We are able to weld successfully steel on steel, or steel on iron.

When bringing a tube up to welding heat great care must be exercised to heat uniformly, not too rapidly, and be sure not to overheat the steel safe end, thus making it brittle and resulting in failure in service, the fracture usually taking place through the steel portion near the weld.

The superheater flues of 5½-in. and 5¾-in. diameter are cut off at the front flue sheet. After removal they are brought to the blacksmith shop to be cleaned and welded. We place about twenty of these flues in the rattler and mix with them one hundred tubes 2 in. in diameter. From two to four hours in the rattler cleans them very thoroughly. They are taken from the rattler and cut off at the firebox end. We do not scarf our safe ends on large superheater flues, but leave the safe end and flue full stock. We weld our superheater flues on the front end. The flues are then taken from the cutting-off machine to an oil furnace, heated and belled out with full thickness of material and safe end applied, then put back into the furnace, brought up to a welding heat and welded on the 200 lb. Bradley belt-driven hammer, for which we have constructed special mandrel and dies. We use three men for this operation, a flue welder and two helpers. We average about 11 flues per hour in welding and about 22 flues per hour in swedging on this machine. Superheater flues and 2 in. tubes are electric welded in the back tube sheet. We expect tubes so welded to last three years.

E. A. Wilkins (Pere Marquette) stated that flue welding at the Wyoming shops (Grand Rapids, Mich.) of the Pere Marquette was handled entirely in the boiler shop. As they are removed from the engine the tubes are placed on a special truck of convenient height. The truck is then pushed by three men to the flue rattler and stock shed. The arrangement for filling the rattler is such that two men can handle 250 or 300 tubes into it in 10 min. All the work on the tubes is done by three men, including rattling, cutting stub ends, heating and welding, cutting to length, testing and annealing, loading on the truck and returning it to the boiler shop. The output is at the rate of 60 to 75 tubes per hour of either 2-in., 2¼-in. or 3-in. diameter, either steel or iron. The arrangement of the flue furnace, welding machine and swedging block, together with the elevated welder's rollers, is such that the welding, heating, swedging and kicking the flue back into the receiving rack may be accomplished by the operator without moving out of a four-foot circle. From the time the tube leaves the rattler it is never handled twice in the same operation, and the entire job is completed at a cost of 3.69 cents per tube. Superheater flues 5¾ in. and 5½ in. in diameter are handled in the same manner, but at an increased cost, owing to the fact that but from 15 to 20 of these flues can be handled per hour. All tubes are applied to the boiler at a cost of 6.535 cents each, making a total cost of tubes out and into the boiler, in 100 lots, of 10.225 cents per tube, or \$10.225 per hundred.

MAKING AND REPAIRING FROGS AND CROSSINGS

F. A. Watts (Delaware, Lackawanna & Western) described the method employed in the frog and switch shop at Dover, N.

J., where a large amount of new work is handled. The shop is divided into three departments; a blacksmith shop, where all forgings, plate work, rod work and switch stand shafts are repaired; the planing and drilling room, and the erecting floor, where work is assembled, bolted up, riveted and finished ready for shipment. All rail drilling is done on a four-spindle multiple drill and planers of the heaviest type are in use.

The monthly output of this plant was given as follows:

- 150-175 switch points.
- 150-175 pairs frogs complete.
- 8-10 crossings of various angles.
- 6-8 slip switches.
- 100-150 switch stands.
- 500 pairs of compromise angle bars (approximately).

Rails are received by the carload and enter the shop near the rail bed, where they are unloaded. They are then handled to the saws by two operators, who saw them to length and deliver them to the drilling machine. They are then passed to a bench, where the reinforcing bars are riveted on, after which they go to a planer and then to a second planer for the last operation. They are then passed to the bender or straightening machine and thence to the riveting bench, where the lugs are riveted on. A pair of points has not traveled over 50 ft. from the saws in any direction during these operations. The labor cost on a 16-ft. 6-in. switch of 101 lb. rail is approximately \$4.

In making frogs the points and side rails are passed from the saws in one direction to the bending machine, where they are bent to template, next to the drilling machine, where they are drilled for riveting together, and thence to the planer room, where operations are performed on three planers. The point and side rails are riveted together near the last planer, and then pass to the erecting room. The wing rails when sawed go in the opposite direction, passing directly to the erecting room, where the bender and drill presses used on them are located. The handling of material is facilitated by the use of tramway tracks and air hoists, and the arrangement of the plant is such that when finished the frogs are piled not over 125 ft. from the rail pile whence came the new material.

The cost of cutting up old frogs, handling the scrap material to and from the hammer, and placing it in piles ready for shipment never exceeds 20 cents per frog. This low cost is due to the use of a special rivet buster of local design. In cutting up old frogs all frog plates, reinforcing bars, tie plates, spikes, bolts, nuts and other material fit for future use, or which can be reclaimed, is saved, with a net saving to the company of \$25,000 per year more than would be received if the material were sold for scrap.

CARBON AND HIGH-SPEED STEEL

H. W. Loughridge (Pittsburgh & Lake Erie): Nearly every mechanical magazine, each month, has an article of some kind on steel and its uses. The steel makers furnish working directions for each kind of steel that is made by them. It would therefore seem that with so much information and data at hand it would be impossible to go wrong, were it not for the fact that fully two-thirds of the articles written are not read by the men who do the work. The articles are all good and written by men who thoroughly understand what they are writing about, but their enthusiasm carries them away, with the result that the man on the job or at the forge is lost in a dense fog.

In considering the forging, annealing, hardening and tempering of the various grades of straight carbon steel, we are confronted with a much more difficult proposition than when considering high-speed steel, from the fact that most carbon steel has a very limited range of treatment, being more sensitive and easily ruined in forging and hardening. Therefore greater care must be taken in selecting the kind of steel most suited to the kind of work it is to be used for and on ascertaining and following the correct method of forging and hardening to produce the best results.

We have heard considerable about the critical temperature of steel, the fact being emphasized that this is the proper heat

to harden, but we do not hear anything about the forging operation, which has just as much to do with the life of the steel as the hardening process. In fact, no amount of heat treatment will be of any use if the forging has not been properly done. This also applies to the annealing process, which must be properly done. A simple way to overcome this trouble would be to put it up to the company from which your steel is purchased. Let them give the carbon content, the forging temperature, the hardening temperature, the annealing temperature. After receiving this information and following the instructions, if the steel should be a failure it will be up to manufacturer. High-speed and carbon alloy steel seem to be coming into quite general use, and as both of these require higher temperatures for forging and hardening, carbon steel must and does suffer. As it was a hard proposition to get men to heat to a high heat when high-speed steel was first introduced, it is now equally hard to get them to heat carbon steel at a low heat. The majority of failures in carbon steel can be traced to too high heat either in the operation of forging, annealing or hardening. Keep the heat down, never forge below the critical point, never anneal below the critical point, always harden at the lowest heat at which the steel will harden, and be sure that the forging, annealing and hardening heats are uniform. By a uniform heat I do not mean that you should let the heat go away up to 1,600 or 1,700 deg. F. and then cool back to 1,450 or 1,500 deg. F., and attempt to harden then.

As an example, heat a piece of steel to 1550 deg. F., let it cool back to 1,450 or 1,475 deg. F. and quench. Break the end and you will find the steel will show the effect of 1,550 deg. F. High-speed steel must be heated to a much higher temperature for forging and tempering than carbon steel. A temperature of 1,400 deg. F. to 1,600 deg. F. is sufficient for most carbon steels. High-speed steel requires from 1,800 deg. F. to 2,300 deg. F. It is best at all times to follow the instructions of the makers. High-speed steel should never be forged below a bright yellow heat. If unable to finish the job in one heat put it back into the fire and finish in a second or third heat if necessary. Heavy lathe tools should be put into the fire after forging and warmed up to 1,450 or 1,500 deg. F. and allowed to cool. This will relieve any strain that may have been set up in the forging operation.

Tempering of Taps and Dies.—The methods used at the P. & L. E. shops at McKees Rocks, Pa., are as follows: Two muffle furnaces are in constant use; one is kept at 1,400 to 1,450 deg. F., and the other between 2,000 and 2,200 deg. F. All carbon steel taps and dies hardened in the low temperature furnace, the heat always depending upon the critical point of the steel being used. Then cool in clean water at about 60 deg. F. They are then drawn in oil at 450 or 500 deg. F. The larger tools are treated in the same manner, only they are held in the water until the vibration ceases, then put into cold oil until cold and drawn immediately to the desired temperature in oil. High-speed steel is first preheated in the low temperature furnace to about 1,450 deg. F., then put into the high temperature furnace and held at about 1,900 to 2,000 deg. F., then quenched in the oil and drawn to 500 or 600 deg. F., the temper depending on the tool.

DISCUSSION

The importance of care in heating steels was brought out in the discussion and there was a pronounced expression among the members in favor of the use of modern appliances in the heat treatment of steel, especially in the manufacture of taps and dies and reamers. Where the open fire must be used the importance of regulating the temperature of the fire to agree with the temperature desired in the steel was brought out, as it is impossible to take a red heat out of a white fire. To insure against warping of reamers and taps the importance of providing a perfectly straight forging before finishing in the lathe was emphasized, good results having been consistently obtained where this practice is followed. The use of carbon steel is being considerably reduced by the introduction of alloy steels. It is the

general opinion that many of the failures in forging and heat treating steels which are attributed to the blacksmith are due to a lack of knowledge on his part as to the quality of the steel and therefore as to the proper methods of heating for forging and hardening in the shop.

PIECE WORK

P. T. Lavender (Norfolk & Western): When we have a piece of work which is standard and will be ordered in sufficient quantities to justify setting a price, we first make our necessary dies and formers for either the drop hammer, forging machine or bulldozer. The dies are then tried to see that the work done is in accordance with blue print and the workman and foreman then agree on the price to be paid. I have found that by following this rule of handling piece work there is no difficulty in getting along with the men. We are told that the piece work system causes men to do their work hastily and carelessly. We can easily see that this is not true, for in such cases as unsatisfactory work is done it is turned back to the man to be done over on his own time. Piece work brings out the best in a man and it teaches him how to handle himself and to think ahead. It makes a man self-reliant.

A. W. Ackley (Delaware, Lackawanna & Western): Some foremen have the idea that piece work is simply a way of increasing wages and forget that by altering the price on this or that job they are simply destroying the object of piece work and making trouble for themselves. Prices cannot be changed to favor one man and not another without causing friction among the men. When the foreman changes the method of doing a certain piece of work the price should be adjusted at once. I have known cases where changes have been made and the price left unchanged in which the foreman eventually had to resign simply because he had not taken advantage of the tools he had created.

Some foremen leave the making and repairing of parts to the judgment of the blacksmith doing the work. Naturally this man is going to take the easiest and best paying method for himself. You may have all kinds of prices for straightening certain classes of work and allow the highest price all the time. Spring hangers may be sent from the erecting shop for annealing and the blacksmith will touch up the end and, of course, close the holes when they are not worn enough to warrant such additional work. The blacksmith foreman should see personally all work coming to the shop and be in a position to say just what should be done in all cases. When setting piece work prices the foreman should see that the method of doing the work is according to his instructions, as in numerous cases work can be made to take much more time when setting a price than after the price has been set.

J. H. Daltry (Erie): We work about 60 per cent piece work at our Buffalo, N. Y., shops, both on repair and new work, and I consider it the best way of doing work. After a man works on piece work he does not want to return to day work. It is claimed that as good work is not secured under the piece work system as by the day, but I do not think that is true. We very seldom have a job to be done over. If a man is required to do a poor job over again on his own time he will be more careful afterwards to do his work right the first time.

RECLAIMING SCRAP

Thomas M. Ross (Buffalo, Rochester & Pittsburgh): The scrap pile, when properly handled, is one of the most economical and important features in connection with railroad service. In many instances material can be found in the scrap pile which answers the purpose as well as new material. For instance, old rake handles, brake levers, brake rods, jaws, brake hangers, etc., can often be used again to advantage. Old arch bars, draw head pockets, truss rods, etc., are re-rolled into different sizes of round iron, which is then used in the manufacture of bolts, grab irons, engine rakes, and used for general repair work. The arch bars are sheared into small pieces, and the draw head pockets are cut into pieces by acetylene gas. These pieces are then heated

in the furnace and split by rolling machine, and then rolled into the different sizes of round iron required. These methods are only adopted when rolling smaller than one inch round iron. When rolling one inch round iron, and over, whole arch bars are used. Steel crank pins are used in numerous cases for making wrenches and small forgings. Coil springs are extensively used in the manufacture of car repairer's drift pins, and pinch bars. Tire steel is principally used for making car repairer's hammers, and coal picks. It is not suitable for tools that must withstand blows from sledges, owing to its tendency to break off in chunks. Machine tools which become too short or otherwise defective are drawn out and made into smaller tools.

J. Tootell (Chicago & North Western): The North Western began to sort out scrap about 20 years ago, each year doing a little more. Some five or six years ago we went into the proposition more extensively and reclaimed everything of usable value. Two shops were built of lumber from old cars, one 24 ft. by 180 ft., and the other 40 ft. by 180 ft. These shops contain the following equipment:

- 5 Bradley hammers for straightening old bolts.
- 4 nut strippers to strip nuts from bolts and rods.
- 3 double and one single shears for cutting old bolts to length and also for cutting up scrap and rods for the rolling mills.
- 1 steam hammer for removing pockets from old couplers, straightening deadwood plates, draft stems, brake levers, etc.
- 1 upright power hammer for straightening rods.
- 2 rolling mills to roll from 3/4 in. to 2 in. round iron.
- 5 oil furnaces: One for the steam hammers, two double furnaces for the rolling mills, one for springs, and the other for straightening miscellaneous material.
- 1 small bulldozer for bending pin lifters, brake hangers, etc.
- 1 drill press and emery wheel for repairing old monkey wrenches, shovels, etc.
- 1 machine for making new grab irons.
- 5 forges for straightening connecting rods, grab irons, and switch rods.

We have a spring plant for resetting and tempering coil springs and a tester for testing them before they are put in service. We also repair all switch stands in these shops, all air cylinders, valves, steam and air hose, straighten track spikes and sort out nuts and washers. From 20 to 25 cars of scrap are unloaded per day; about five old cars are burned and seven broken up per day. All scrap is sorted as it is unloaded, and distributed to the various shops where repairs are to be made.

The following statement will give an idea of some of the work turned out in the reclaiming plant in one month: Rerolling iron, 3/4 in., 7/8 in. and 1 in. round, 361,791 lb.; straightening and cutting to length old bolts and rods, 257,950 lb.; 3,158 draw bar and truck coil springs reset and tempered. These items cover only the material reclaimed from condemned cars.

C. L. Gay (Atlantic Coast Line): We have been reclaiming all of the round iron used from 1/2 in. to 1 in. in diameter. This is done on an Ajax rolling machine. Manufactured material which has been used and thrown into the scrap pile bent up in various shapes is sorted out and hauled to a two-door Ferguson oil furnace about 8 ft. long. Two men, one at each door, fill up the furnace; after the material is heated it is taken to a straightening slab and brought back to shape. When cool it is removed to a platform nearby, from which it is used as needed. The following is a summary of the operation of the reclaiming rolls at the South Rocky Mount, N. C., shops for the month of December, 1914:

The amount of round iron from 1/2 in. to 1 in. in diameter reclaimed for the month was 51,803 lb., the saving account of reclaiming (difference between price of new iron and scrap value) being \$336.72.

COST OF RECLAIMING.

30,000 lb. at contract price of \$2.50 per ton.....	\$37.50
21,803 lb. at day rates (Includes the time of one head roller, one assistant head roller, one head feeder and two assistant feeders for 39 hours each)	72.82
Total cost of fuel, electricity, overhead charge and repairs.....	148.92
Total cost of reclaiming	\$221.74

Deducting \$221.74 from \$336.72 leaves a net saving of \$114.98

for the 11 days of operation during the month of December, 1914.

SPRING MAKING AND REPAIRING

Thomas E. Williams (Chicago & North Western): In so far as possible, all the spring work for a system should be concentrated at the main shop of the company. Small outlying plants do not pay, for spring work should under no condition be attempted without proper machinery and, as a rule, it is not advisable to install such machinery at outlying points on account of the small amount of work to be done. Once there becomes work enough to allow of the installation and operation of the proper spring making machinery, further expansion is very easily taken care of, because the same number of machines are necessary for a relatively large amount of work as for a small amount. While the quantity of work is still small a workman may operate more than one machine. For instance, at the Chicago shops of the North Western, four machines are required to prepare the steel for use. At present, one man and two helpers operate all four machines. Should the amount of work increase all that would be necessary would be to hire more operators. The tempering furnace is most influenced by quantity of work. Provision must be made for more doors in case of an increase of work. Practically the same equipment is suitable for both new and repair work.

For the manufacture of new springs the material is received in bars from 12 ft. to 18 ft. in length. The first operation is to cut the bars into proper lengths. All pieces of the same length are cut at the same time. The next operation is that of punching the leaves requiring it and the third operation is that of centering all plates on a nibbing machine. The next operation is rolling out the ends of the leaves, which are now ready for fitting and tempering. A standard form is kept for the first leaf of every standard spring and, when this first leaf has been rolled and hardened, all the remaining leaves are easily made by rolling to the preceding leaf. The rolling and tempering are done at the same heat, about 1,650 deg. F. As soon as the leaf is shaped, it is plunged in an oil bath and allowed to cool, after which it is placed in the furnace and allowed to remain there until the oil flashes. The leaves are then piled in their proper order and are ready for banding. This is done by first gripping them in a hydraulic clamp and slipping on a temporary band which holds them until the permanent one is applied. For the application of the permanent band a hydraulic press is used. The band is first heated to about 1,850 deg. F., slipped over the spring and then squeezed in the press and held until cool. The spring is now ready for service—except for painting. Occasionally springs are tested to see that the proper standards are being maintained. Repair work is handled practically the same way as new work. All spring bands used are machine made. After the material has been sheared off to the proper length, it is bent into a U shape on a bulldozer, and the weld made in a forging machine. No broken bands are repaired, as the machine made bands are so cheap that a band once broken is scrapped.

For shaping material five machines are used: A combination shearing and punching machine; a roll served by a furnace, for tapering leaf ends; a nibbing machine for putting the centers in the leaves; a trimming machine, and a gibbing machine. The fitting and tempering apparatus includes a furnace for heating and tempering face plates, tanks for oil baths and hand rolls for rolling the leaves to shape. The finishing machinery includes a hydraulic clamp, a hydraulic banding press served by a furnace for heating bands, and a testing machine for trying the springs. For the operation of this equipment fifteen men are regularly employed

C. V. Landrum (Nashville, Chattanooga & St. Louis): I found that on springs rolled with the convex roller on the bottom the plate was cupped so that when loaded the strain was on the edge of the plate, making it much easier to break. I reversed the conditions, which had the effect of putting the tension on the center of the plate, and compressed the edges. The result proved satisfactory, as it reduced the number of failures from that cause. The plates are rolled and cooled off at the same heat,

then another hot plate is rolled on it, which is all the drawing the spring sets. The most of our failures have from one to three top plates broken, and in nineteen times out of twenty the balance of the spring retains its correct set, requiring very little work to put it back into service. We use crude oil for tempering purposes, with air from the shop blast to keep it cool. We have a shop-made machine which we call a spring machine. It will nib, roll, trim, slot and crimp the main plate for the gib, all in one machine worked by air. We also have an attachment that centers the plate lengthwise and sidewise, leaving no measuring or center punching to be done.

If we could get the same grade of steel all the time, the spring failures would be reduced to a very great extent. Different grades of steel mixed together, calling for different treatment which can not be given, for the simple reason that the smith cannot tell one grade from the other, will forever cause spring troubles, and the sooner the railroads realize this fact the sooner they will save the money that now goes to the spring steel scrap heap.

Geo. P. White (Missouri, Kansas & Texas): All of our springs are repaired on a store department shop order, thereby keeping a stock of springs on hand, and not returning to the engine direct. By this system we repair our springs in lots of not less than six of each class. We have a template for our main plates, fitting all six main plates to the template. Our first plates fitted are cool enough to proceed with the second plates by the time

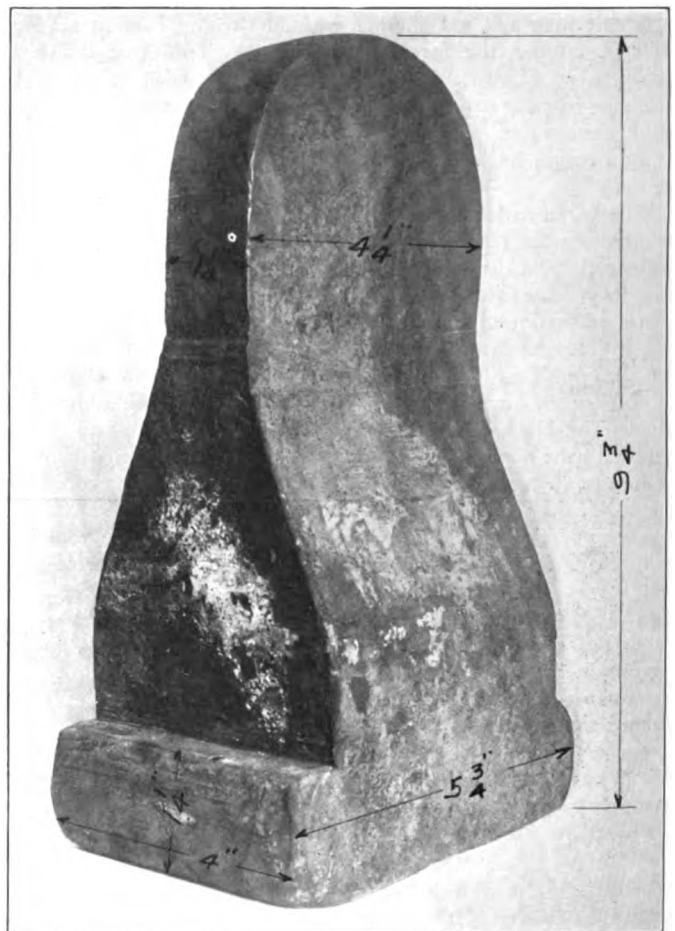

Fig. 1—Locomotive Spring Hanger

the sixth plate is fitted. This way there is no loss of time waiting for plates to cool in the oil, and flashing the temper. After the entire springs have been fitted up they are turned over to a helper to flash the temper. This is done in muffled chamber at a much lower temperature than in the fitting furnace, thereby eliminating a large number of broken plates caused by edges of the steel spring being drawn and the center remaining hard; also spring not carrying the load on account of temper being drawn

too far. Our bands are bent on a bulldozer and welded up on a forging machine at a very low cost compared with the old methods. They are pressed on with a hydraulic machine such as is used in nearly all large repair shops.

Each spring has the class number and date repaired stamped on the band.

DISCUSSION

Attention was called to the need of proper appliances in the manufacture of springs, especially in the heating and drawing of the plates. The question of tapering the ends of the leaves brought forth considerable discussion. This practice has been abandoned by the Pennsylvania and the Lehigh Valley, the leaves being sheared and hardened without finish on the ends, with

day's production should be subjected to a transverse deflection test. Mr. Russell submitted the accompanying table showing the deflections for various spans and thicknesses of material, which indicate that the material has an elastic limit of not less than 120,000 lb. per sq. in., providing the material does not receive a permanent set to exceed .01 in. After the deflection test the plates should be broken and the angle at which failure occurs observed. This angle should not be less than shown in the table; the greater the angle the better is the heat treatment.

DEFLECTION AND BREAKING TEST OF SPRING PLATES.

Thickness of Steel, Inches.	Transverse Span in Inches.	Deflection Test.	
		Deflection in Hundredths of an Inch.	Breaking Test. Minimum Angle of Breakage, Degrees.
1/4	18	104	63
9/32	18	93	55
5/16	18	83	50
11/32	18	76	46
3/8	18	69	42
13/32	18	55	39
7/16	24	114	36
15/32	24	99	33
1/2	24	93	31
17/32	24	87	29
9/16	24	82	28
19/32	24	78	26
5/8	24	74	25

CASE HARDENING

C. V. Landrum (Nashville, Chattanooga & St. Louis): I use the old method of casehardening—bone meal, old leather, pulverized charcoal and a little sprinkling of prussiate of potash. I use a drum 12 in. in diameter and from two to four feet long, the length being governed by the amount to be hardened. I turn a slight flange on one end of the drum, stand it on end, cut

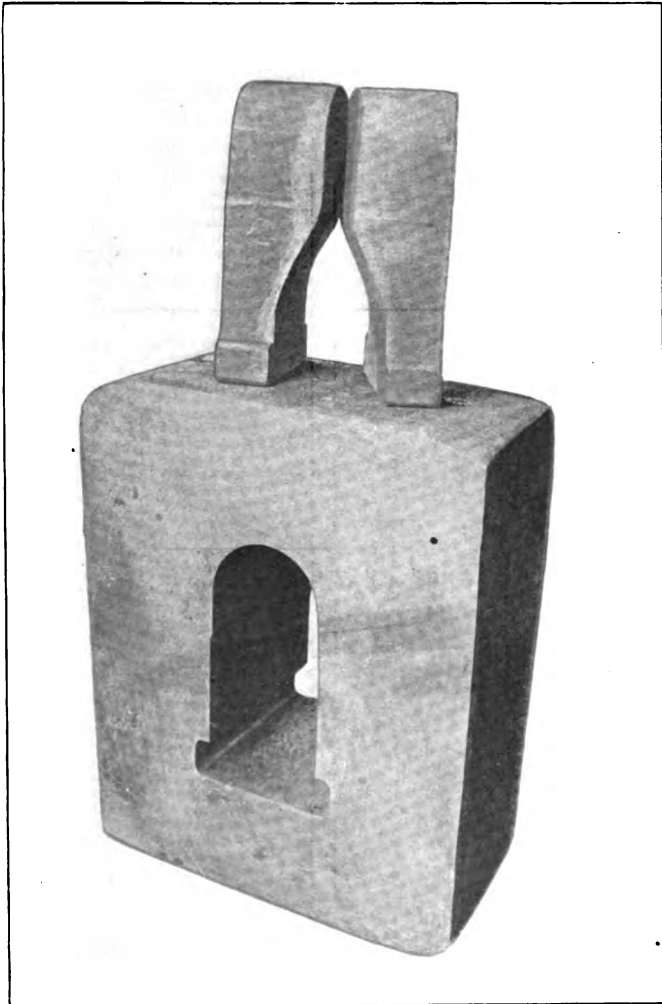

Fig. 2—Cup and Blocks for Forming Spring Hanger Shown in Fig. 1

apparently satisfactory results. Several of the members, however, objected to this practice on the ground that it tends to destroy the uniformity of the flexibility of the springs. The use of machine-made spring bands is quite general. They are applied with a banding press and allowed to cool while clamped in the press, thus preventing the tension of the spring from stretching the hot band. The fact was emphasized that one-fourth of trouble with plate springs is the varying quality of steel, the variations being unknown to the blacksmith, who is thus unable to handle the material properly.

J. W. Russell (Pennsylvania Railroad) stated that where pyrometers are used they should be checked by means of a test pyrometer kept for that purpose. The test pyrometer should be checked occasionally by means of a salt bath, the melting point of salt being very near to the high point used in heat treating spring steel; that is, about 1,472 deg. F. Two plates from each

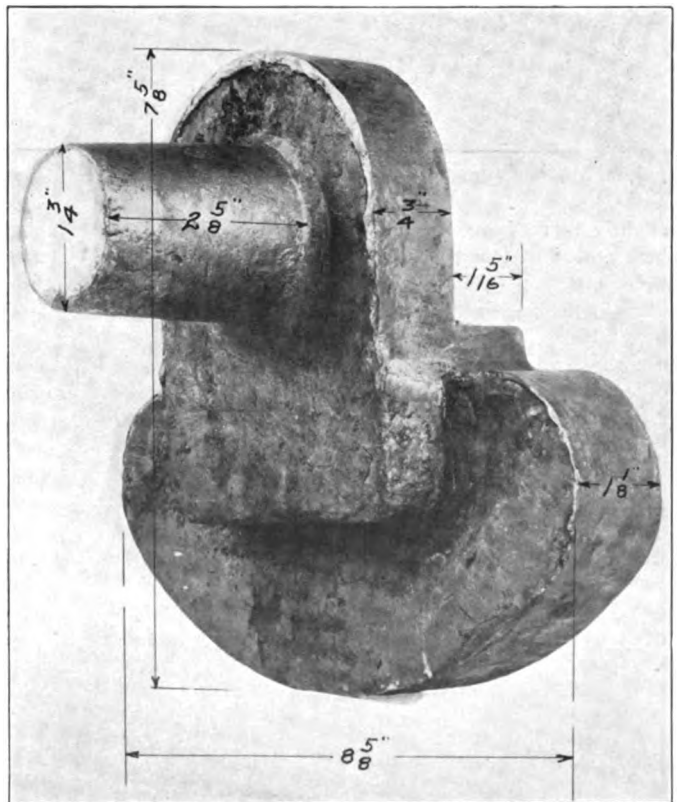

Fig. 3—Link Trunion

out a piece of 1/4 in. or 3/8 in. iron to fit, then drop it in and put about two inches of fire clay on top of it, pack it well so as to make it as near air tight as possible, then put in about 2 in. or 3 in. of bone meal and old leather, cut up; then a layer of pieces to be hardened is packed in. Space is left at the top for two or three inches of fire clay, which is held in place by another 1/4 in. or 3/8 in. iron plate, a 5/8 in. bolt passing through holes in the drum to keep it in place. It is then placed in the furnace and kept 1,600 or 1,700 deg. F., as near as I can come to it without a pyrometer.

That temperature maintained for eight hours will penetrate $\frac{1}{8}$ in. deep. If the heat is lower the case will be thinner. For quick work or a roundhouse job I use $\frac{3}{4}$ lb. of prussiate of potash to 1 gal. of pulverized charcoal. This put in a pipe just large enough to accommodate the pieces to be hardened and kept at the highest practicable temperature one and a half hours will penetrate $\frac{1}{16}$ in., making a good hard case. Both ends of the pipe must be closed with fire clay.

DROP FORGING

J. W. McDonald (Pennsylvania Railroad): We do not have a drop forge hammer at our shops. However, we are following out work along the same line by using cup blocks, from which we get very good results, although we have a flash to trim by hand.

Fig. 1 outlines a spring hanger support for one of our heavy locomotives used in passenger service. This piece is made from hammered iron and is first roughed down to 4 in. by 5 in. by 6 in.

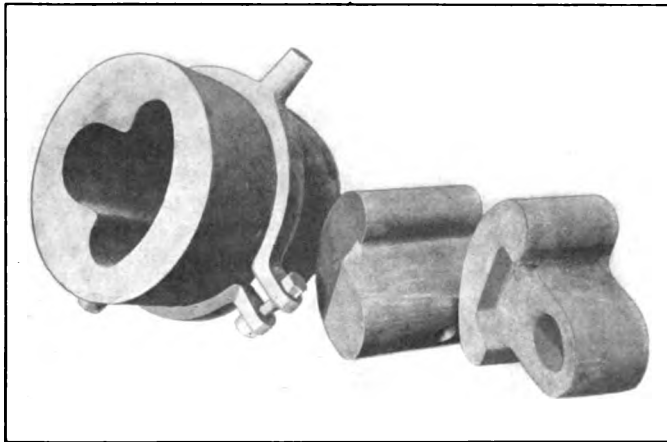

Fig. 4—Cup and Blocks for Forming Link Trunnion Shown in Fig. 3

slightly tapered on one end. It is then reheated to a welding heat and placed in the die between the top and bottom blocks; these are then driven together by steam hammer until the top block is flush with the top of the die. After the cup die is raised up, by using blocks underneath it and by using a plunger to drive out the work and forms, there is no further labor to be done other than to trim the flash. The die and block are shown in Fig. 2. We have just recently completed 400 of these pieces at a very low cost, although the cost is somewhat higher than the same work done in drop-forge dies. There is a very large saving in

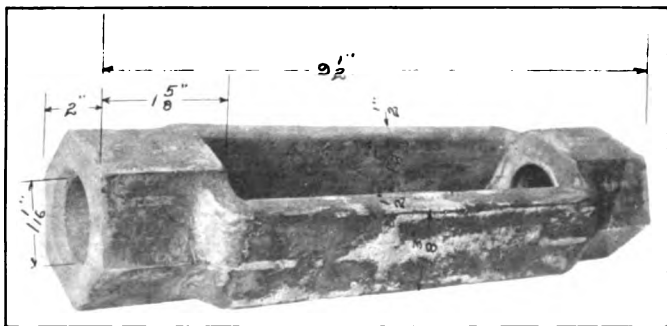

Fig. 5—Turnbuckle Formed in Dies Shown in Fig. 6

labor cost as compared to forging and finishing at the anvil. In making this piece we start with 34 lb. of material; after the flash is removed the finished piece weighs $32\frac{1}{2}$ lb. It is necessary in forming work in cup dies to have just about the right weight, otherwise the strain on the tools is very severe, due to surplus stock finding its way between the cup and plunger. The cup block is made of billet steel; the top and bottom forms are made of tool steel.

Fig. 3 shows a link trunnion and Fig. 4 the cup and blocks for forming it. We first forge this piece from hammered iron, and bend the stem at right angles to the body, which is forged square. This will assure that the fibres of the metal will flow in the direction intended, assuring a solid stem. The iron is then re-heated to a welding heat, then placed in the die between top and bottom blocks and the top block driven down flush with the top of the die under the steam hammer. After the flash is trimmed we have the finished piece as shown in Fig. 3.

We form the top and bottom ends of smoke-box frame braces in dies used on our 5,000-lb. steam hammer, impressions being cut out in the dies to properly form the pads on the ends.

Fig. 5 is a $1\frac{1}{4}$ -in. turnbuckle, the dies for making which are shown in Fig. 6. The iron is offset 3 in. from each end, $\frac{1}{2}$ in. deep. Then two pieces are placed together and after taking a welding heat on one end are placed in the bottom impression of the die. After the first operation we have the hex formed on one end with a hole about $1\frac{1}{4}$ in. deep. A round face plunger is used in this operation. This answers two purposes: first, one need not use any filling-in piece; and, second, it sets out the corners by plunging the hot metal against the solid center of the die. It is again re-heated to a welding heat and placed in the top impression in the die, where the plunger punches out the slug and at the same time stencils the shop and company's mark. This completes the first end. The same operations are followed on the other end, after which the work is ready for tapping

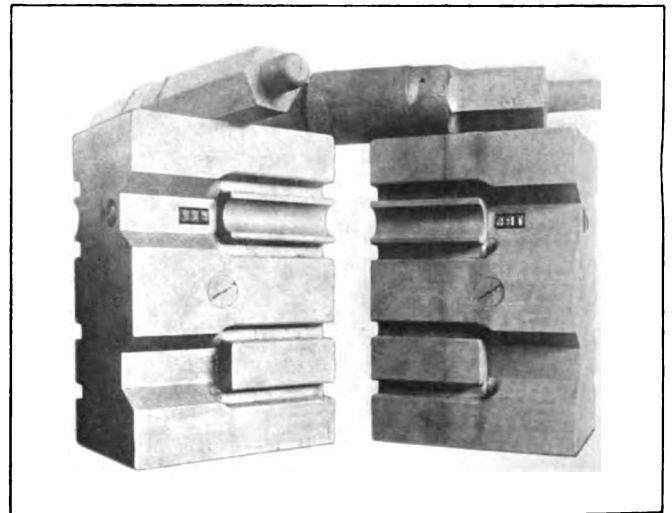

Fig. 6—Dies for Forming Turnbuckles

the thread. While there is a small flash this is removed by placing about 300 pieces in the flue rattler and rattled about two hours, not using any water. This removes the flash and polishes the work at the same time. This turnbuckle is made at a very small labor cost. The dies are made of scrap axle steel with a tool steel insert in the center of the die for punching the hole.

DISCUSSION

H. E. Gamble (Pennsylvania Railroad): We are running our drop hammers night and day. The largest dies we have in use measure 12 in. by 30 in. by 36 in. and weigh 3,560 lb. each. They are of Vanadium cast steel. We have not as yet been successful in eliminating the breaking of hammer rods and dies, heat cracks appearing in the latter from continuous use.

ELECTRIC WELDING

Joseph Grine (New York Central): It is our opinion that electric welders in locomotive shops should all be placed under the blacksmith foreman for the following reasons: (a) His knowledge of the properties of, and the effects of heat on iron and steel places him in a position to handle this work very successfully. (b) His access to all classes of work in all departments places him in a position to get up new methods of doing

the work and to advantageously balance up the work in all departments. (c) Because of the specialized nature of this work it can be handled better by one man with access to all departments than by each department head. Standardization of practice is more readily attained. The blacksmith foremen have taken the wrong attitude and tried to avoid or shirk this responsibility. At the shop on the railroad with which I am connected, we

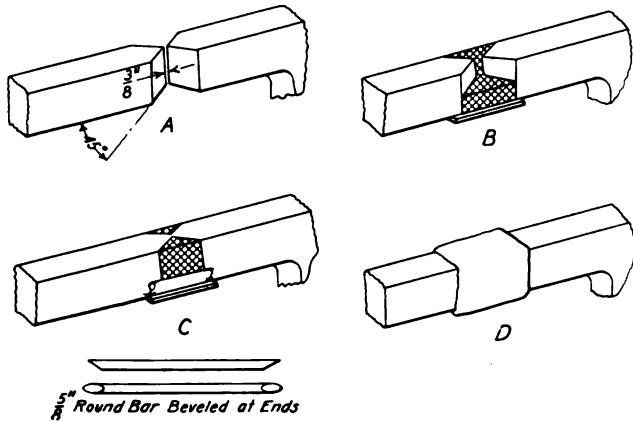

Fig. 7—Method of Arc-Welding Frames

are using the electric-welding machines on a large number of different operations, some of which, with the saving effected, are given below:

No. of Units	Description of Work	Approx. Saving Effected
265	Broken frames welded.....	\$15,000.00
60	Cracked cylinders welded.....	14,000.00
28	Front deck castings welded.....	1,360.00
325	Fireboxes welded.....	890.00
137	Sets of flues welded in back flue sheet....	*1,000.00
76	Sharp flanges filled in tires.....	650.00
78	Flat spots filled in tires.....	700.00
40	Mud rings welded or reinforced.....	400.00

*Per year in maintenance of these flues.

It is conservatively estimated that the annual saving at this

Experience has shown us that in almost every class of work satisfactory results can be obtained without the use of flux, providing the parts to be welded are clean.

The frame at crack is first V'd out on both sides with the oxy-acetylene cutting flame, and chipped out with an air hammer and chisel to get a clean surface as shown at A in Fig. 7. A 5/8-in. plate, about 1 in. wider than the frame, is then fastened to the bottom. From this as a basis the electric welder builds up the full width of the frame first on one side and then on the other as shown at B. After the V is filled on both sides, 5/8-in. round bars about 2 in. longer than the full width of the V are welded on the outside as reinforcement, starting at the bottom and building up (see C, Fig. 7). The very fact that these bars are round enables the operator to easily and successfully weld them in by being able to get in around them. The completed weld is shown at D.

A great number of shops use the electric-welding process very successfully in fireboxes, welding cracks, applying patches, applying new side sheets and 3/4-door sheets, filling up corroded or worn places in all sheets, welding mud rings, welding in tubes in back-tube sheet, welding cracks in bridges and checks in flanges of sheets. In welding in tubes, the tubes should be applied the

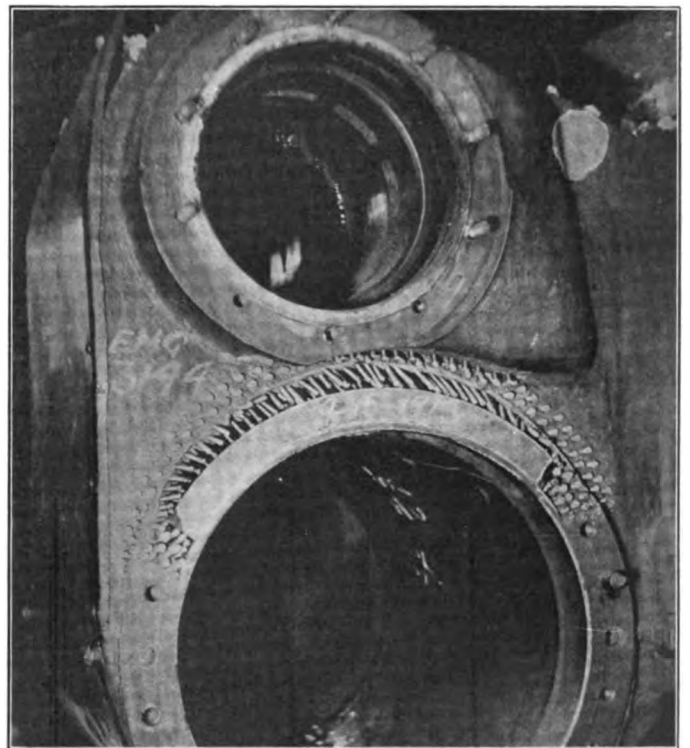

Fig. 9—Cylinder Prepared for Welding

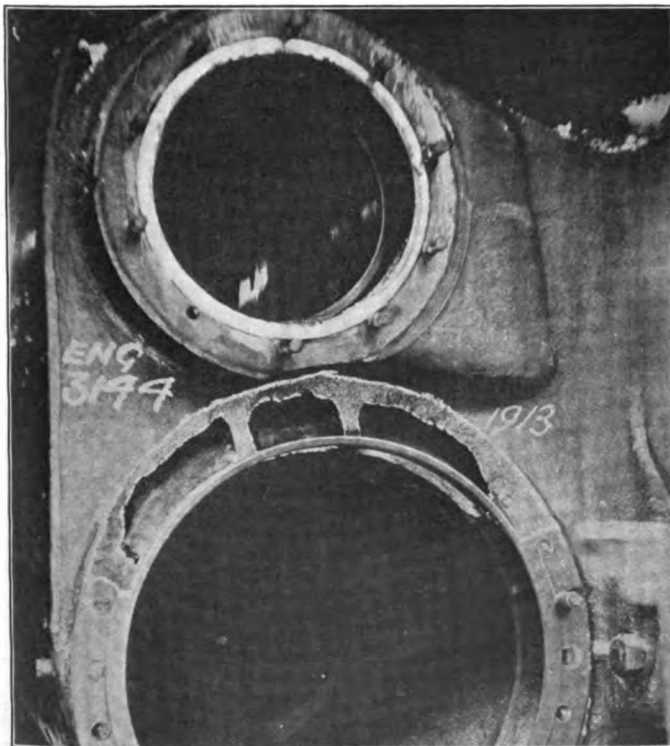

Fig. 8—Broken Cylinder Repaired by Arc Welding

one shop is approximately \$30,000. All savings noted above are net savings above cost of labor, material and electric current to perform the operations.

same as if no welding was to be done. After they are applied the sheets should be cleaned and roughed before welding. Care should be taken that the voltage is not too high. A voltage of 64 with 125 amperes gives good results. Welding tubes is most economical in good water sections where two or three years may be expected between renewals, but it pays to weld them if only one year is expected of them, as it saves engine-house troubles.

An engine came to the shops with left cylinder broken over the three steam ports, a space about 36 in., with the cylinder bushing still intact, as shown in Fig. 8. The cylinder was drilled and tapped for 1/2-in. studs, in order to provide, through the steel or iron studs, something suitable on which to anchor the electric welding. Fig. 9 shows the studs applied and a quarter circle of 2 1/4 in. by 2 1/2 in. soft steel faced off and bored to fit the radius of the cylinder placed on top of bushing. The back part of this piece was beveled off to form a scarf. The electric welding starts at the top, gradually working the metal down into the

circle, care being taken to avoid closing the steam ports. This engine has been in service since October 1, 1913, and up to date has given no trouble from this weld. Welding a crack the full length of cylinder with this method is a very simple job. The crack is first cut in V shape at an angle of 45 deg. and a row of 1/2-in. studs placed on each side of the V about 1 in. or 1 1/4 in. apart. It is not necessary to let studs project over the cast iron more than 1/4 in.

Manufacturers sometimes do not give the operators a chance to master the process before they make up their minds that the method is not feasible. It does not require as skillful handling to make a good arc weld as it does to make a good weld on an anvil.

In order to show the relative strength of electric welds compared with the original material welded, a test was made of four pieces of 3/8-in. firebox steel welded by the electrode process. These were placed in a testing machine and the breaking strain found. One piece broke in the original steel and the other three pieces broke through the weld. The results are given in the table:

Breaking strain per inch width.	Per cent strength of material.	Remarks.
21,700 lb.	99	Broke through weld
19,900 lb.	91	Broke through weld
21,840 lb.	100	Broke in steel
18,090 lb.	82	Broke through weld

All four test pieces were reinforced according to our standard practice.

C. A. Slenker (Long Island Railroad): We did not accomplish much with our machine outside of boiler work and not a

have welded a number of experimental pieces and upon breaking them we find the material at fracture is laminated with layers of slag and scale throughout the entire weld and we also find it

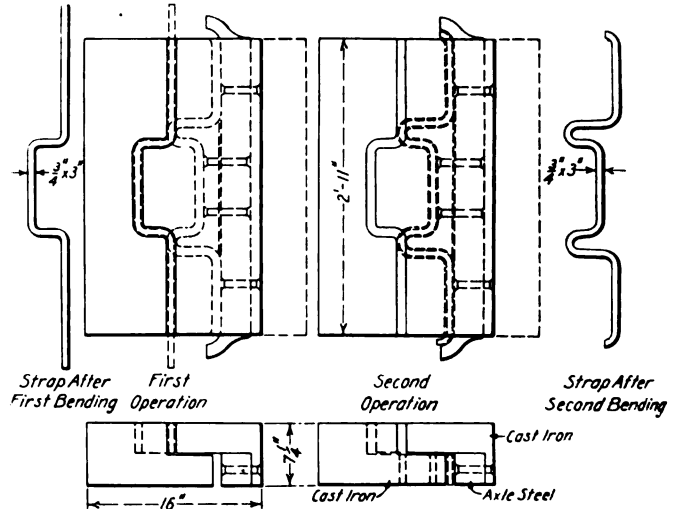

Fig. 11—Former for Making Brake Beam Safety Straps

crystallized. If we could keep the slag from forming, I believe we could do a fairly good job.

There is a company in Newark, N. J., called the Quasi-arc Weltrode Company. The only point in which their scheme differs from the ordinary pencil arc-welding is in their "weltrode,"

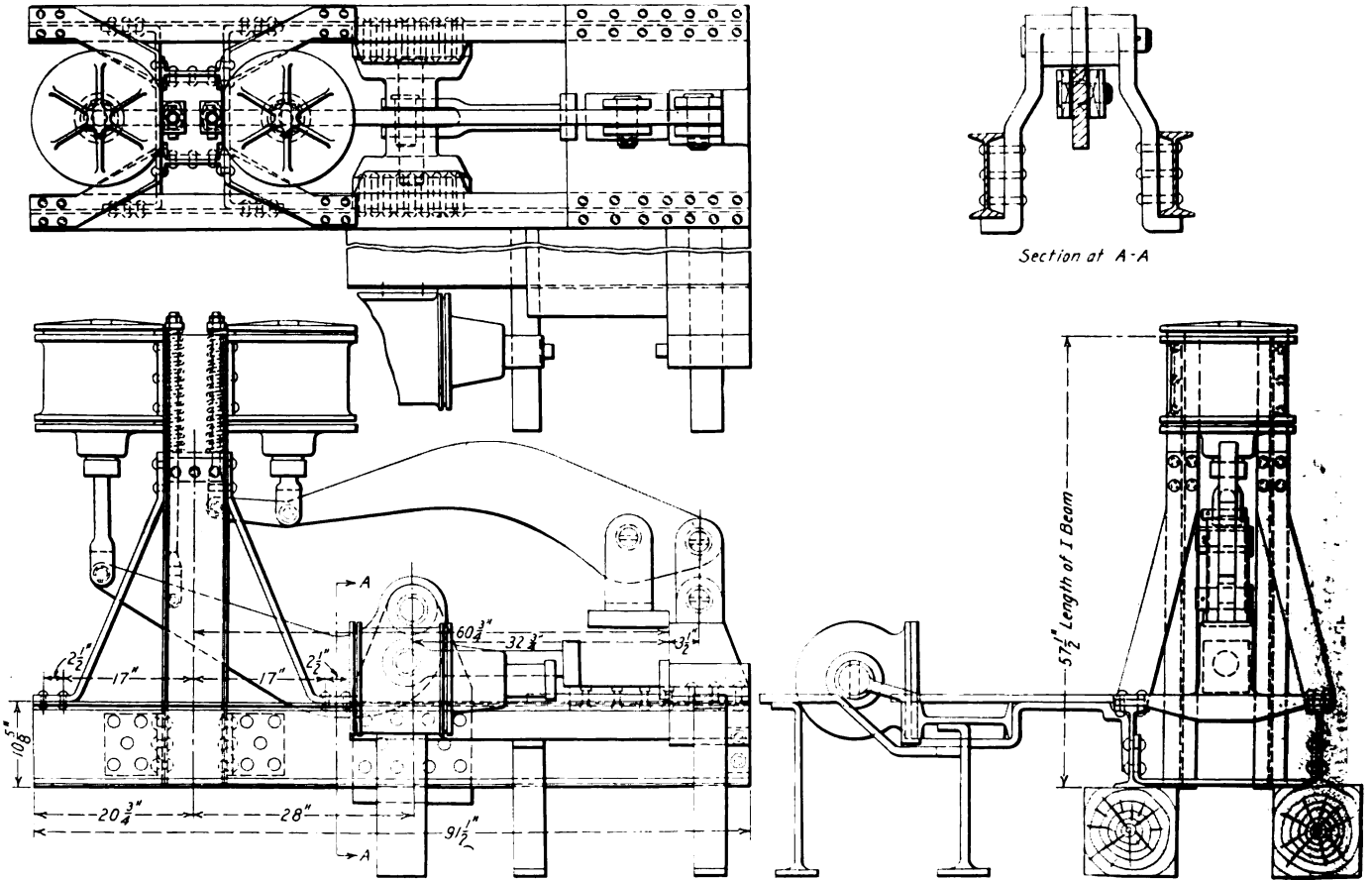

Fig. 10—Spring Banding Machine

great deal of that. As to heavy welding, such as locomotive frames and mud-ring corners, we have not done any of that kind of work yet. Where a forging is removed from an engine, such as spring hangers and brake rigging, we cannot do it cheaper with electricity than in the smith shop. I have tried it out carefully and compared it with my piecwork prices and I find that the smith shop is cheaper on piecwork basis. We

which consists of a metallic rod covered with slag. It is not necessary for the operator carefully to hold his arc; the slag on the end of the weltrode rests on the work when the arc is drawn between the end of the wire and the work. As the wire melts away, the slag also melts, the claim being that the air is entirely excluded from the molten metal. As each layer of metal is applied the slag forming on top is broken away with

a scaling hammer. A wire brush is used thoroughly to clean the top of new metal that has been added and then the next layer is applied.

P. T. Lavender (Norfolk & Western) said that the electric

electrode and separate filling rod, since there is no tendency for carbon to be carried into the weld. Because of the action of the arc in carrying the metal from the electrode to the work, it is possible to weld on a vertical wall or overhead. This method

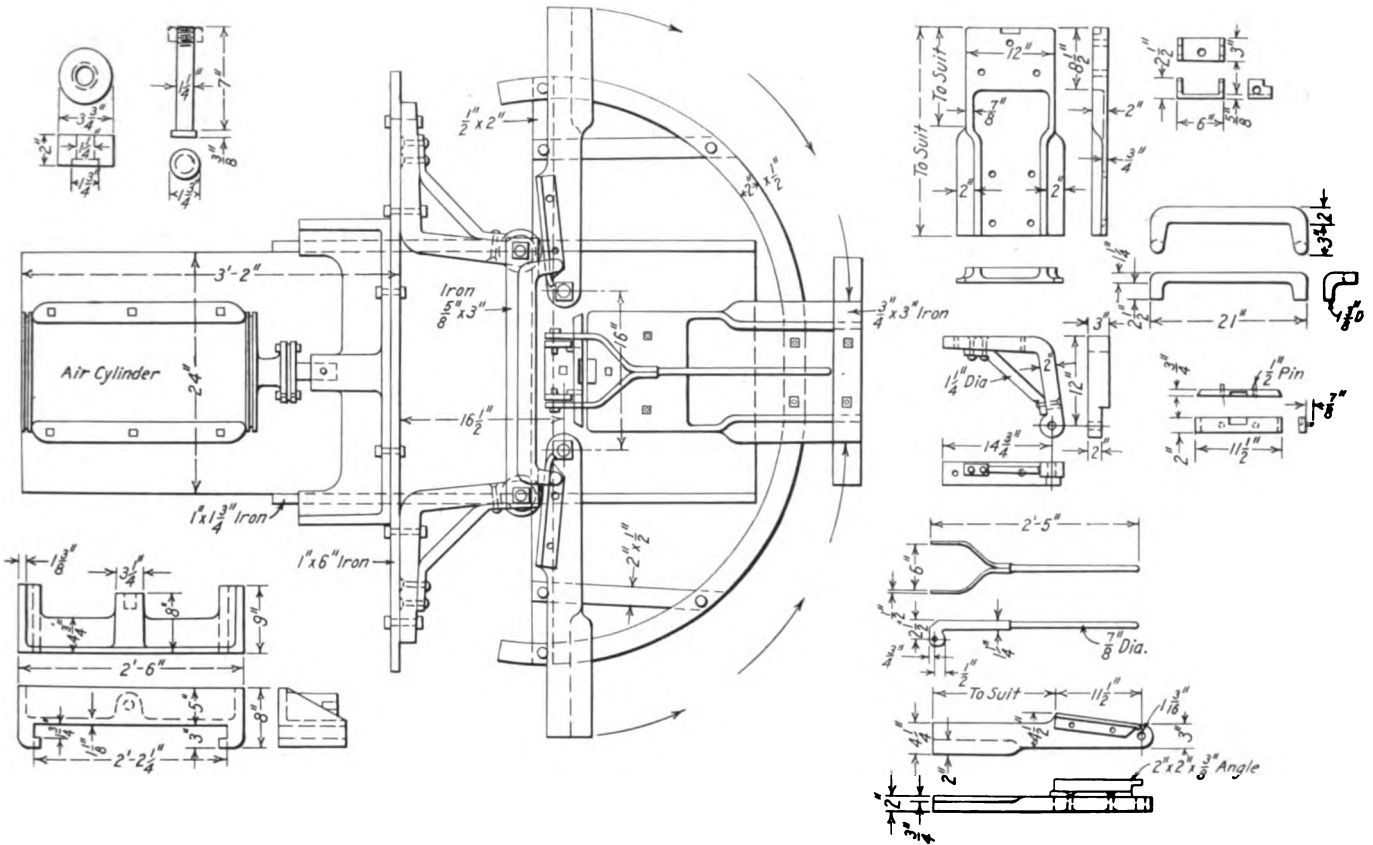

Fig. 12—Device for Forming Sill Steps in One Operation

welding at the Roanoke shops is under charge of the erecting and boiler shop foreman. The method employed is the metallic electrode method. The arc is drawn by touching the work

is largely used in overhead repairs in the firebox and in welding tubes in locomotive boilers. It is of great value where repairs must be made in place. The following is a summary of an actual test made at the Roanoke shops to determine the relative tensile strength of coke butt-welded, electrically butt-welded and new unwelded tubes. There were tested 18 pieces of tubes, six of each kind. The unwelded tubes were found to have an average tensile strength of 37,921 1/3 lb. The coke welded averaged 33,236

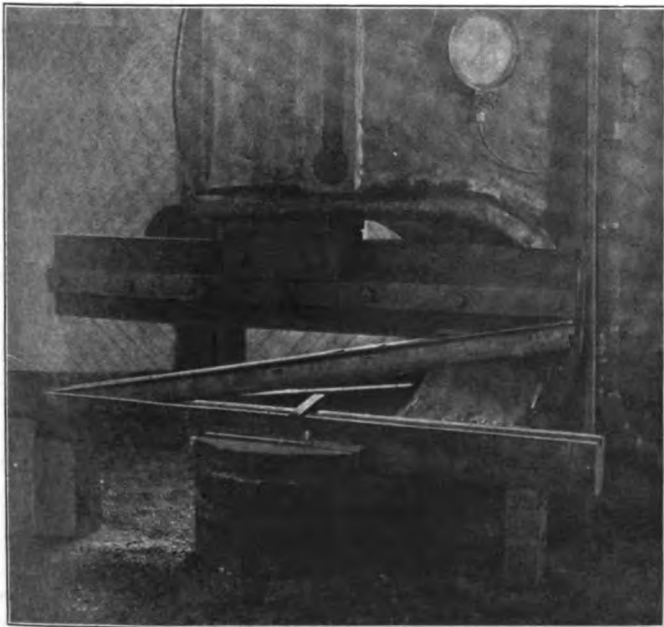

Fig. 13—Form for Bending Channels Into Stakes for Steel Cars

with the metal electrode and drawing it away, the filling being accomplished by the melting away of the electrode itself. This method will make a softer weld than the process using a graphite



Fig. 14—Formers for Making Brake Mast Supports

lb., with a corresponding efficiency of 87 2/3 per cent, while the electrically-welded tubes had an average tensile strength of 34,020 lb. and an efficiency of 90.6 per cent. The minimum efficiency of any of the six specimens of electrically-welded tubes was 80 per cent. The structure of the material at the weld seems to be

very satisfactory and we are of the opinion that the process possesses decided advantages over the original method of welding in furnaces and fires.

DISCUSSION

Trouble has been experienced by some of the members in welding mud rings, and in welding in tubes, due to the cracking of the bridges in the tube sheet. In heavy work, such as mud rings, the trouble experienced is lamination of the successive layers of metal applied.

Joseph Grine (New York Central) stated that many mud rings have been welded at the Depew (N. Y.) shops, the mud rings being scarfed the same as frames and welded either from the bottom or top. Lamination is avoided by applying each successive layer against the direction of application of the preceding layer. In welding boiler sheets the electric process is superior to oxy-acetylene because the latter generates too much heat and causes the sheet to buckle. In welding in tubes electrically the work should be done by skipping about between points a considerable distance apart, thus tending to equalize the expansion of the sheet.

HEAT TREATMENT OF METAL

No report was presented on this subject, but it brought out considerable discussion.

H. E. Gamble (Pennsylvania Railroad) stated that the Pennsylvania was increasing the heat-treating plant at the Juniata shops. In addition to the larger parts, such as axles, side rods and piston rods, crosshead tees, gib bolts, etc., are all heat treated. Nothing is quenched in oil except very light, thin sheet steel. On all other material flowing water is used and three

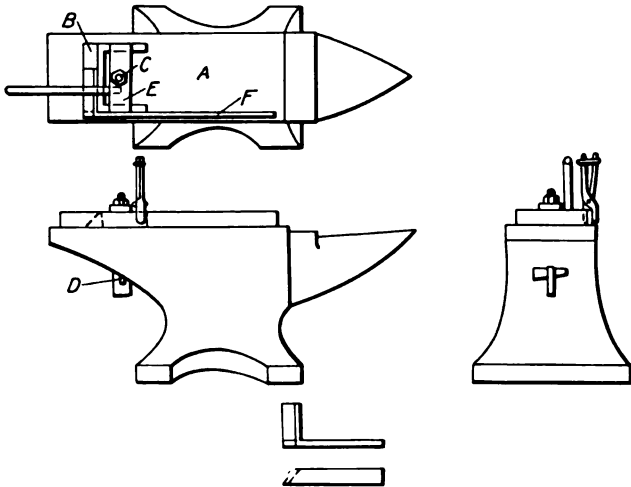

Fig. 15—Attachment for Bending Oblique Angles on the Anvil

heats are recommended. After the forging has been done the parts should be annealed, then the quenching heat taken and finally the drawing heat. The material should be rough turned before heat treating.

The fact was brought out that where heat-treated side rods are used the effect of the heat treatment may be destroyed by bringing the rods into the shop and heating them to straighten or to slightly lengthen or shorten them. As soon as the temperature is raised above that of the original draw point the material will require heat treating again to give it its original properties.

SHOP KINKS

C. A. Slenker (Long Island Railroad) : Fig. 10 shows a spring-banding machine with an assembly table attached. This machine was built out of scrap collected at the shops. It has two plungers, one vertical and one horizontal, operated by air pressure. The pressure on each plunger is about 95,000 lb. The frame is built up of two horizontal and two vertical I-beams, the cylinders being secured to the vertical members and the level

fulcrums and table to the horizontal members. We also have an oil-tempering tank, to which a small pump is attached and run with air pressure. This pump sucks the hot oil off the top and circulates it in coils in running water and discharges in bottom of tank; the temperature of oil as it discharges is about 130 deg. F.

W. J. Mayer (Michigan Central) : Fig. 11 is a former for making brake beam safety straps. This was rather a difficult job on account of the short bends and the amount of stock required between the outside bends. We make this in two operations, making the inside bends first on the top part of the former, then turning the piece over and dropping it down, completing the job on the next revolution of the bulldozer. This former is cast iron, except the male part of the lower former, which is a forging

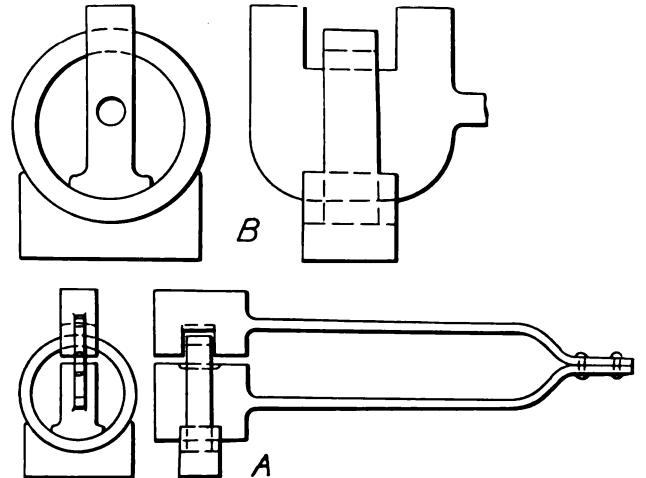

Fig. 16—Device for Forming Rings Under the Steam Hammer

made of scrap steel axle. I have been in a number of shops where sill steps were being made and have examined the formers. The formers illustrated in Fig. 12 will do this job in a satisfactory manner. They are of cast iron with angle iron pieces riveted to the arms and machine steel forgings for the yoke. They are used on a home-made air bulldozer with a 10-in. by 22-in. cylinder, and bend and twist the ends of the sill steps in one operation.

F. P. Deissler (Bessemer & Lake Erie) : Fig. 13 shows a form used on our 300-ton forging press to bend channels for stakes on steel cars. The channels are 5 ft. 2 in. long and are 9-in., 20-lb. sections. A channel is placed on the bottom form, flanges down, and is shaped by being pressed into this form with the tongue of the upper die. The finished stake is shown in the photograph. We also use this machine for stripping yokes from couplers, the rivets being sheared by pressure exerted against the coupler shank by the ram of the press. Because of the steady pressure exerted the yoke of the coupler is not mashed or broken and no rivets or tools fly about the shop as is often the case where this work is done under the steam hammer.

Fig. 14 shows formers for making brake mast supports on a bulldozer. This support is 5/8 in. by 2 1/2 in. in section and has several angles, which are difficult to deal with. The straight bar is placed on the former and bent as at A. It is then passed to the other side and bent in another former as shown at B. The completed brake mast support is shown at C, this work all being done at one heat and all pieces being uniform. The formers are made of gray iron with no machine work except facing for bearings and drilling holes for fastening to the machine.

H. E. Gamble (Pennsylvania Railroad) : Fig. 15 shows an attachment for use on the anvil in bending bevel angles in one operation. The advantages of this device can well be appreciated when compared with the older methods of doing the work by hand. The construction of the attachment is shown at A. The work is formed on a cast-iron block B, which is made to the desired angle and is held in place by means of a bolt C with a head slotted for a wedge at D. The bar of iron is shown in position for bending at F and is held in position by the clamp E.

Fig. 16 shows a device for forming rings under the steam hammer. The effect of bending in this manner by the hammer and exerting an even blow at each stroke is much better on the material than forming with a mandrel and sledge.

OTHER BUSINESS

The secretary's report showed the addition of 13 new members and a cash balance of \$48.48.

The following officers were elected for the ensuing year: President, T. E. Williams, Bettendorf Company; first vice-president, W. C. Scofield, Illinois Central; second vice-president, John Carruthers, Duluth, Missabe & Northern; secretary-treasurer, A. L. Woodworth, Cincinnati, Hamilton & Dayton; assistant secretary-treasurer, George B. White, Missouri, Kansas & Texas; chemist, H. Williams, Boston, Mass.

Chicago received the largest number of votes as the place of meeting for the next convention.

THE ELECTRIC FURNACE FOR REHEATING, HEAT TREATING AND ANNEALING*

BY T. F. BAILY†

In the twenty-five years that have passed since the early and crude development of electric melting and refining furnaces, there have been put into service more than one hundred of these furnaces, ranging in commercial capacity from 1 to 20 tons, and in electrical capacity from 100 to 3,000 kw. Central stations that twenty-five years ago considered 10 cents per kilowatt-hour a low rate are now, with modern equipments of power generation, furnishing electric furnaces with current for less than ¼ of a cent. Electric furnace loads running into thousands of kilowatts, where now there are but hundreds, operating continuously and with power factors closely approaching unity, will undoubtedly cause central stations advantageously located to look with favor upon rates of ½ cent a kilowatt for such loads. As the dominating factor in electric furnace operation costs must always be the cost per kilowatt-hour, the gradual reduction in the cost of electric current will greatly add to the growth of electric furnace loads for re-heating, heat-treating and annealing.

The type of furnace that seems best adapted for re-heating operations is the resistance type, in which the material to be heated is entirely separate from, and independent of, the resistance elements in which the heat is generated by the electric current. A general description of this type of furnace is as follows: Through the side walls of a furnace shell made of suitable refractories are inserted two carbon or graphite electrodes. The inner ends of these electrodes extend into a trough of highly refractory material. This trough is filled with the resistance material itself, usually some form of broken carbon, and makes contact at each end with the electrodes. The outside ends of the electrodes are connected by means of suitable copper terminals and cables to the regulating transformer and switch, by means of which the voltage impressed across the furnace is regulated, the voltage thrown on the furnace having a definite relation to the current flow and heat input. The material to be heated is placed conveniently adjacent, at the side or above or underneath the resistance material and its containers, as the case may be.

In some heating operations the actual cost of heating per ton is less with electric furnaces than with combustion furnaces, while in some heat-treating and annealing operations the precision with which the operations are carried on must be the justification for the higher cost of heating in the electric furnace. In a general way it may be stated that the higher the temperature at which the heating operation is conducted the

higher the relative economy in the use of electric furnaces. At the lower temperature there is less difference in the thermal efficiency of electric and combustion furnaces.

The principal advantage of electric furnaces over combustion furnaces for re-heating are more accurate temperature control, non-oxidizing atmosphere, saving in space, elimination of blast or stack, evenness of temperature throughout the heating space, simplicity of control, small amount of heat lost to the surrounding atmosphere, and cleanliness of surroundings.

Electric furnaces of the character described may be controlled with great precision, for the reason that a given input of electric current liberates a given quantity of heat units within the furnace, the transfer of electric current to heat being at 100 per cent. efficiency. The walls and doors of the furnaces are the only means for the escape of heat from the furnace in other than useful work, and this loss remains constant for any given temperature and operating conditions. For a given tonnage of metal to be heated to a certain temperature in a given time, it is only necessary to know the heat absorbed by the metal in coming to the temperature and the heat lost by conduction and radiation from the furnace. The voltage across the furnace terminals is then adjusted so that the kilowatts per hour are just sufficient to deliver this heat. In contrast with this simple method of delivering heat into the furnace, the process of converting chemical energy into heat is not usually conducted at an efficiency closely approaching 100 per cent. Besides this, the stack or discharge flues to the combustion furnace are an ever present means of carrying out what should have been useful heat under ideal operating conditions. Any variation in the supply of air or the supply of fuel in a combustion furnace quickly affects the temperature, and both of these do continually vary, both in volume and pressure.

In order to obtain good commercial efficiency in a combustion furnace, an excess of air over the theoretical amount is required. This excess of air creates an oxidizing atmosphere in the furnace chamber which results in scaling the metal under treatment, resulting in a loss of from one to five per cent., depending upon the type of combustion furnace, the temperature, and the man operating the furnace.

As the heat from the resistance units is thrown on the hearth almost entirely by radiation, the temperature of the furnace is more readily kept uniform over the entire area than in combustion furnaces where the heat is delivered to the hearth by the impinging heated gases or products of combustion. Another feature leading to evenness of temperature throughout the electric furnace is that the resistors of the electric furnace may be run at only a comparatively small temperature above that of the hearth of the furnace, while the combustion furnace, for instance, in an annealing operation, requires that the incoming gases from the combustion chamber must of necessity be several hundred degrees higher than the temperature of the furnace.

The actual theoretical heat required expressed in kilowatt hours per ton of metal is as follows for heating to the temperature given:

Material	Deg. F.	Kw. Hrs. Per Ton
Iron	2,200	230
"	2,000	215
"	1,800	200
"	1,650	170
"	1,500	150
"	1,250	115
"	900	75
Copper	1,400	90
Brass	1,300	85
Aluminum	950	140
"	750	110
Silver	1,300	50
German Silver	1,300	75

The thermal efficiencies of electric furnaces vary greatly with the size and capacity in tons per hour. The wall loss on a forging furnace of 60 kw. capacity heating 250 lb. of steel per hour to 2,200 deg. F., will be approximately 30 kw., showing a thermal efficiency of 50 per cent. A furnace of one ton per hour capacity for 2,200 deg. will show an efficiency of 75 per cent.

*From a paper read before the Engineers' Society of Western Pennsylvania at Pittsburgh, April 6, 1915.

†President of the Electrical Furnace Company of America, Alliance, Ohio.

In annealing work a furnace of 100 kw. per hour capacity will heat 600 lb. of metal to 1,650 deg. with an efficiency of 50 per cent; while a furnace of 600 kw. capacity, heating three tons of steel per hour, will show an efficiency as high as 90 per cent. All the above figures are typical for the usual classes of work handled in the capacity named.

The rapid growth of the practice of heat-treating and a realization of the precision with which this treatment must be carried on in order to secure uniform results, has opened a particularly desirable field for the electric furnace, especially as the electric furnace can be more accurately controlled and a greater uniformity of heat throughout the furnace maintained in commercial operation than with combustion furnaces. A comparatively slight variation in either blast pressure or fuel supply in a combustion furnace very quickly affects the ruling temperature, while in the electric furnace, owing to the comparatively great mass of heated refractory material of walls and roof acting as a heat storage or accumulator, the variation in temperature is reduced to a minimum. In practice the current may be off for periods of an hour at a time without affecting the temperature more than a few degrees. This type of furnace may be described as follows: In the usual steel shell is constructed an arched roof of fire brick, so arranged as to reflect the heat radiated from the resister troughs onto the hearth located between the two resister units running lengthwise of the furnace. The material to be heated is handled through the door or doors of the furnace located in the end walls. The hearth, if not subject to mechanical abrasion, is made of suitable fire brick. Where the abrasion is likely to be severe, cast iron plates replace the fire brick. A heat balance sheet of a furnace of this type of 100 kw. capacity and the hearth area 5 ft. by 6 ft., and heating 600 lb. per hour to 1,650 deg. F., will show the following balance:

Heat absorbed by the metal.....	50 kw.
Heat lost through the walls.....	35 kw.
Heat lost through the doors and door openings, due to the frequent charging and withdrawing.....	15 kw.

For furnaces of more than one-half ton per hour capacity, and for higher thermal efficiencies, the continuous type of furnace is desirable. The material, if of uniform section, is pushed through the furnace by direct application of the pusher to the material to be heated. If the parts are small or liable to buckle if direct pressure is exerted on them, they are placed in pans or steel boxes, these containers being pushed through one at a time. If the material is in the form of rods that may be handled through the furnace lengthwise, as, for instance, copper and brass rods or tubes, this material may be placed on steel pans and drawn through the furnace by means of hook and chain, as is common in brass mill practice. A typical furnace of the continuous type for annealing German silver or brass stampings in steel pans has a hearth 15 ft. long by 2 ft. wide, and a rated electrical capacity of 200 k.w. A mechanical charger operated by a motor-driven winch with hand operated clutch pushes the pans in through the charging door one after another, seven pans being in the furnace at one time. The pans passing through the furnace are supported by a hearth made of cast iron grids, each 2 ft. square. The pan when discharged is dumped automatically into a water sealed discharge hood. The metal under treatment falls into a tank of either clear water or pickling solution, depending upon the cleanliness of the material before it is charged. Thus in this furnace the material is not exposed to the atmosphere at any time after entering until taken cold from the quenching tank. This entirely eliminates the possibility of oxidation as the furnace itself has a reducing atmosphere. A heat balance sheet of this furnace heating 1,500 lb. of steel per hour to 1,650 deg. will show the following:

Heat absorbed by 400 lbs. of pans.....	34 kw.
Heat absorbed by 1,500 lbs. of metal.....	127½ kw.
Heat lost through walls and doors.....	30 kw.

The advantage of this type of furnace over the non-continu-

ous furnace is a lower labor cost and the fact that the material when brought to the desired temperature may be more quickly removed, eliminating largely the danger of over-heating, and at the same time allowing the material under treatment to be brought to temperature more gradually.

The type of furnace best adapted to heat-treating which requires precision, is the automatic continuous type, wherein the material under treatment, when brought to the predetermined temperature, is automatically discharged either into the air or into some quenching medium. This method of operation reduces the human element and the chance of error to a minimum. The only part of the operation dependent on the operator is the placing of the material to be heated on the charging platform. When the material at the discharge end of the furnace reaches the maximum temperature, a special pyrometer closes an electrical circuit, which in turn closes, through a suitable relay, the solenoid-operated radial dial switch; the various electrical circuits in turn operate the doors, pusher and quenching apparatus.

The greatest objection to heat-treatment as generally practiced to-day with combustion furnaces, is due to the inability to obtain duplicate results. The automatic equipment just described eliminates the uncertainties of non-automatic equipments and enables heat-treating to be done with as great a precision as it is possible to measure. While with hand operation it is possible to obtain excellent results in actual practice at times, a considerable portion of the material treated will fall below the standard as determined by physical tests.

In heat-treating the saving in operating cost of electric furnaces over combustion furnaces in most cases must come in the elimination of oxidation—as, for instance, on high-grade steel, brass and non-ferrous metals, eliminating large expense in acid, and in labor for the pickling operation. In addition to this, the advantage which outweighs, perhaps, all others, is the precision with which electric heat-treating may be done. It is obvious that it is useless to heat-treat a series of parts that may go to make up a steel structure, as a bridge, a line of rails, or a set of springs or axles of a locomotive, if the method of heat-treatment is such that dependence cannot be fully placed on the gain in physical properties. The failure of a single member of the bridge or a single rail or a spring or axle, is almost certain to cause a catastrophe; hence, without absolute precision in temperature and method for producing that temperature in every piece alike, vital parts of a structure or a machine must be figured on the basis of untreated parts, necessitating a greatly increased weight over that of a design relying on the greater strength of heat-treated parts.

The user of steel to-day is willing to pay the additional cost for the additional physical qualities to be obtained by proper heat-treatment; but he has never been willing and never will be willing to pay for the so-called heat-treatment that has in too many cases consisted of simply putting the material through a furnace. When the engineer realizes that for an additional cost of from \$2 to \$3 per ton he can with certainty get the full value of results possible with heat-treatment, the demand for heat-treated material will be a great many times larger than it is to-day.

PETROLEUM IN CHILE.—The existence of petroleum, it is reported, has been definitely established near Punta Arenas and to the northwest of Tierra del Fuego, Chile. The frequency of the emanations of natural gas makes it probable that the deposits are large.—*The Engineer.*

INDIAN MANGANESE ORE.—The exports of manganese ore from India in April this year were 16,269 gross tons, of which 12,969 tons went to Great Britain and 3300 tons to France. In April, 1914, the exports were 65,533 tons, making the decrease this year 49,264 tons, or 75.8 per cent. Since January 1, no ore has been sent from India to the United States.—*The Engineer.*

NEW DEVICES

BERDAN BRAKE RIGGING

The illustrations show a new type of brake rigging invented by E. G. Berdan, stationmaster at the LaSalle Street Station, Chicago, of the New York Central Lines West. It is designed for the purpose of eliminating the use of brake beams. Fig. 1 shows the top view of the device as applied to one side of the truck. Fig. 2 shows a half section through the gear and racks that operate the shoes, and a section through the connection to the brake rods. The pressure from the brake cylinder is trans-

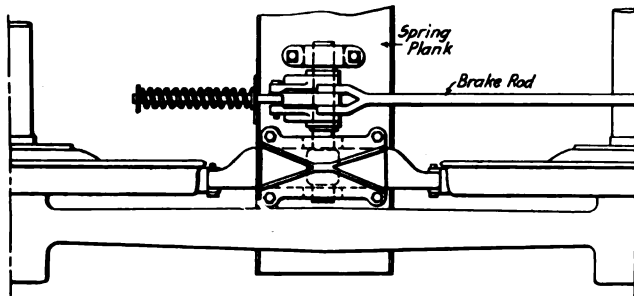

Fig. 1—Top View of the Berdan Brake Rigging

mitted through the regulation foundation gear to the brake rod, which is connected by means of a link to a crank on the gear shaft. As this shaft is turned the gear will rotate, driving the top and bottom racks, to which the brakeshoes are attached, outward, forcing the brakeshoes against the wheel. The mechanism is supported on the truck spring plank, a special housing being required to hold the gears and the rack. With the rack above

coil spring is used, as indicated in Fig. 2, for bringing the mechanism back to normal position, which provides a $\frac{1}{4}$ -in. clearance between the shoe and the wheel. The brake rods are provided with turnbuckles for the purpose of giving close adjustment, thereby overcoming lost motion and maintaining the

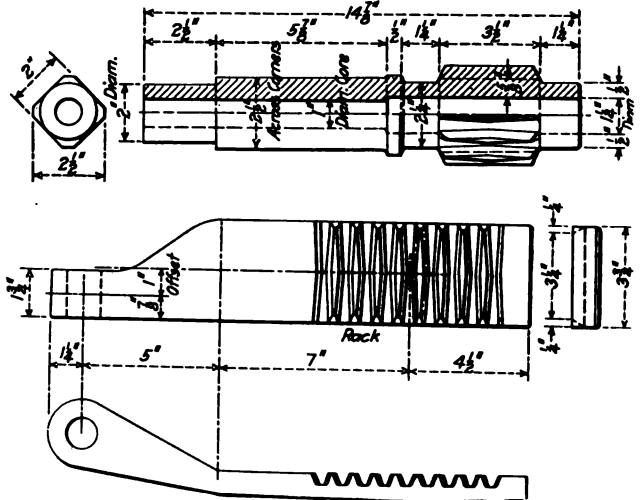

Fig. 3—Gear Shaft and Rack for the Berdan Brake Rigging

proper piston travel. This gear has been in experimental service and is found to work satisfactorily.

KINGAN-RIPKEN VALVE GEAR DEVICE

The photograph shows a new feature that is applied to outside valve gears for the purpose of overcoming the slow action which the combination lever imparts to the Walschaert and similar valve gears. The bottom connection to the combination lever is made to the main rod, as indicated in the illustration, instead of to the crosshead, as is customary. This gives the combination lever a different movement, in that it responds to the up and down movement of the main rod. As the piston is on the last half of the stroke this causes the release, compression

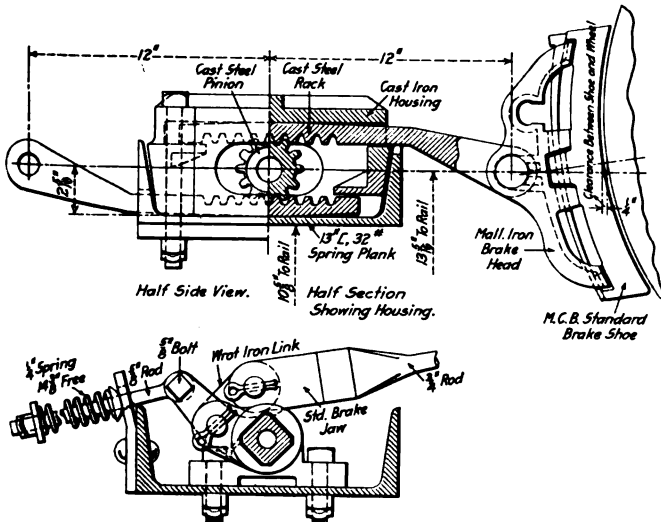
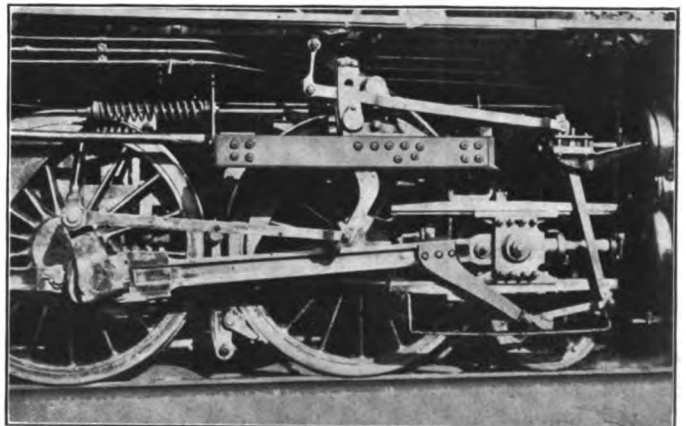

Fig. 2—Section Through the Berdan Brake Rigging

and below the gear it will be seen that as the gear rotates, one brake shoe will act as an abutment against which the gear operates for forcing the other shoe against the wheel.

Provision is made for allowing for differences in wear of the brakeshoes or the loss of a shoe. The gear shaft on its inside end is supported in a curved bearing as shown in Fig. 1, which permits the shaft moving out of alinement. The outside bearing of the gear fits in a slotted hole. The change made in the gear and racks to accommodate this movement is shown in Fig. 3. It will be seen that both the gear and the racks have their teeth tapered each side of the center line, thus providing a free working arrangement for all positions of the gear shaft. A $\frac{1}{4}$ -in.



Application of the Kingan-Ripken Valve Gear Device

and pre-admission to occur later in the stroke with the same cut-off, thereby giving a longer period of expansion, less compression and less pre-admission with the same amount of lead. At the end of the piston travel, the main rod being in the center of its oscillatory movement, the arrangement will have no effect

upon the lead, but as the piston leaves the end of its travel and the main rod again assumes an angle, a quicker, larger and longer-maintained port opening is obtained with the same cut-off, and also a longer cut-off with the reverse lever in the same position. It is also claimed that this arrangement will give a more even distribution of steam to the cylinders; it will permit more uniform valve events and allow the use of a shorter cut-off with its consequent saving of steam. This fact, combined with the longer maximum cut-off obtainable, should provide a quicker starting, faster, more powerful and more economical engine.

A number of locomotives on the Minneapolis, St. Paul & Sault Ste. Marie have been equipped with this device. The patents are controlled by the Kingan-Ripken Company, 2627 Lincoln St., N. E., Minneapolis, Minn.

AIR BRAKE HOSE

A new method of rubber hose construction, known as the Subers process, has been developed by the Goodyear Tire & Rubber Company, Akron, Ohio, and applied in the manufacture of standard M. C. B. air brake hose. This process makes possible the production of a hose of uniform thickness and eliminates the tendency to twist or contract under pressure.

In the making of what is termed wrapped hose, the fabric is cut on the bias, overlapped and wrapped directly over the tube. The lap of the fabric in hose of this type varies the thickness often as much as 1/32 in., and when cut through, a section of the material clearly shows that the fabric is not thoroughly impregnated with the rubber. The wrapping material in the Subers process consists of parallel strands or cords combined into strips, each strip consisting of about 288 strands and being approximately 1/16 in. thick by 1/2 in. wide. Every strand is separately coated

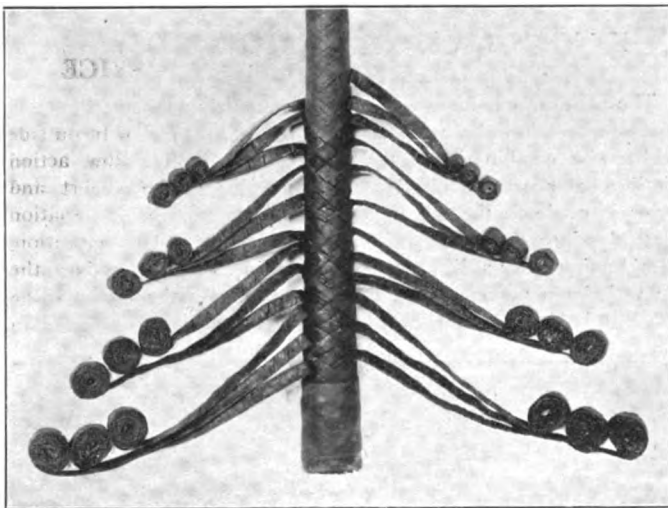

Method of Wrapping the Tube in the Subers Process

with rubber compound, which binds the strands in each strip firmly together, the impregnation of the fabric being thus very complete. The strips are wound spirally about the tube or lining of the hose, there being two complete layers in each direction. The strips in each layer are separated by a space equal to their own width and there is no overlapping. The manner in which the strips are applied will be clearly understood by referring to the illustration.

Hose of this construction shows a specially high bursting pressure and the distorting effect of the pressure is minimized. The elongation per foot per 1,000 lb. pressure will average about 1/8 in., with an expansion of about 1/16 in. in the diameter, there being no twisting or contracting. Until a pressure of 1,300 lb. has been reached, however, but little change takes place.

At the present time the manufacturers are confining their

production of this type of hose to the standard air brake hose in lengths of 22 in., but later expect to adapt the process to the manufacture of car heating steam hose, pneumatic tool hose, etc. The air brake hose now being manufactured conforms to the Master Car Builders' specifications presented at the last convention of the association. It is being used by several railroads.

EMERGENCY COUPLER HEAD

The drawing shows a coupler head for emergency use which has recently been brought out by Frank B. Hart, Railway Exchange Building, Chicago. This head is intended to overcome the troubles incident to the use of heavy chains between cars in a train that has parted through failure of any vital part of the coupler in front of the striking horn.

The emergency head consists of a dummy knuckle cast integral with a 1 1/4 in. shell or plate, both sides of which conform to the contour of the coupler head. One side of this plate is placed on the coupler head and the other forms a standard contour for the mating coupler on the adjacent car. Lugs are cast on either side of the dummy head, in which are cored elongated slots. The ends of a yoke which passes back of the horn of the coupler enter the slots in the lugs and are secured by means of tapered

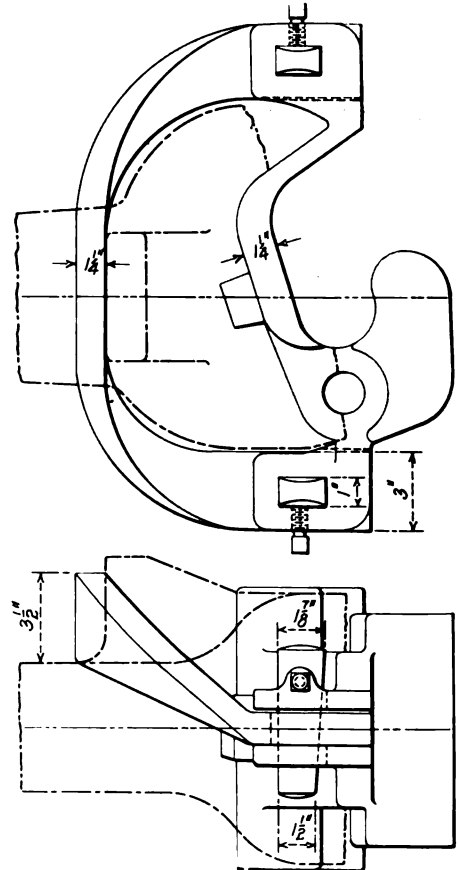

Emergency Head for Temporary Use on Broken Couplers

keys. When driven into place the keys are locked by means of set screws shown in the drawing.

The parts are designed to provide sufficient strength to enable a car having a broken coupler to be handled anywhere in the train. This makes it unnecessary to switch out the damaged car should it be well forward in the train and place it at the rear end. The emergency head sets into the coupler head between the lugs to which the knuckle is pivoted and is provided with a vertical pin hole so that in case these lugs are not broken the pin may be inserted, thus relieving the keys of a portion of the load.

Such a device has several advantages over the chains which are commonly used in emergencies of this kind. It is lighter and much

more compact and may be much more quickly applied and secured. It eliminates the excessive slack with the attendant destructive effect to the equipment and lading and it permits the recoupling of the air brake hose, thus maintaining full air brake control of the train back of the broken coupler without switching out the damaged car.

deck to lower deck may be used. The lower roof sheets may be formed with vertical flanges at the sides of the deck and

ROOF CONSTRUCTION FOR PASSENGER CARS

In building passenger car roofs of the clere-story type there has always been more or less difficulty in securing a substantial upper deck construction which may be cheaply built and in which a satisfactory casing is provided around the deck sash and screens. The accompanying drawings show a type of construction recently patented by Otto B. Johnson, New Glasgow, Nova Scotia, which is designed to overcome these difficulties and to simplify the securing of weather-proof connections between the lower roof and the deck.

In this construction the roof frame consists of special pressed steel channel sections, forming the carlines and upper deck posts, to the outside of which are fastened the roof sheets and to the inside of which the interior finish is applied. The sides and roof of the upper deck are covered with continuous sheets formed to the contour of the roof. Flanged openings are provided in these sheets for the ventilator screens, which are secured against the edge of the flange by means of a wire clamp. The deck posts are secured at the bottom to the upper ends of the lower carlines and to the deck sill angle, the three pieces being securely riveted together. The upper ends are bent to form a connection with the upper carline. With this construction the soldering of flashing around the posts is avoided, which is unsatisfactory and expensive, and continuous roof sheets from lower

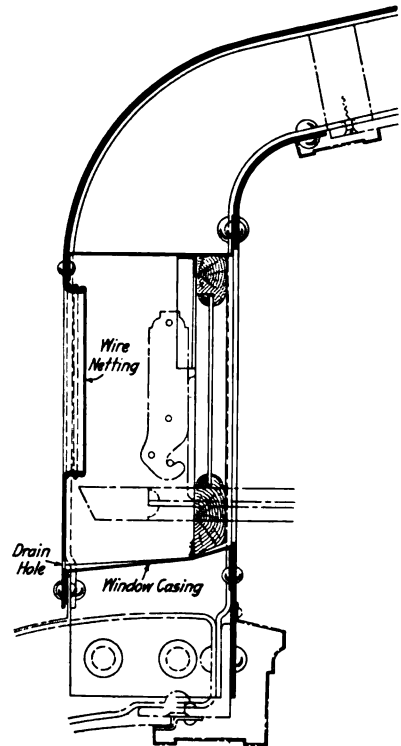

Detail of the Deck Sash Casing and Flashing

directly riveted to the upper roof sheets.

Instead of having a continuous flashing and sash frame

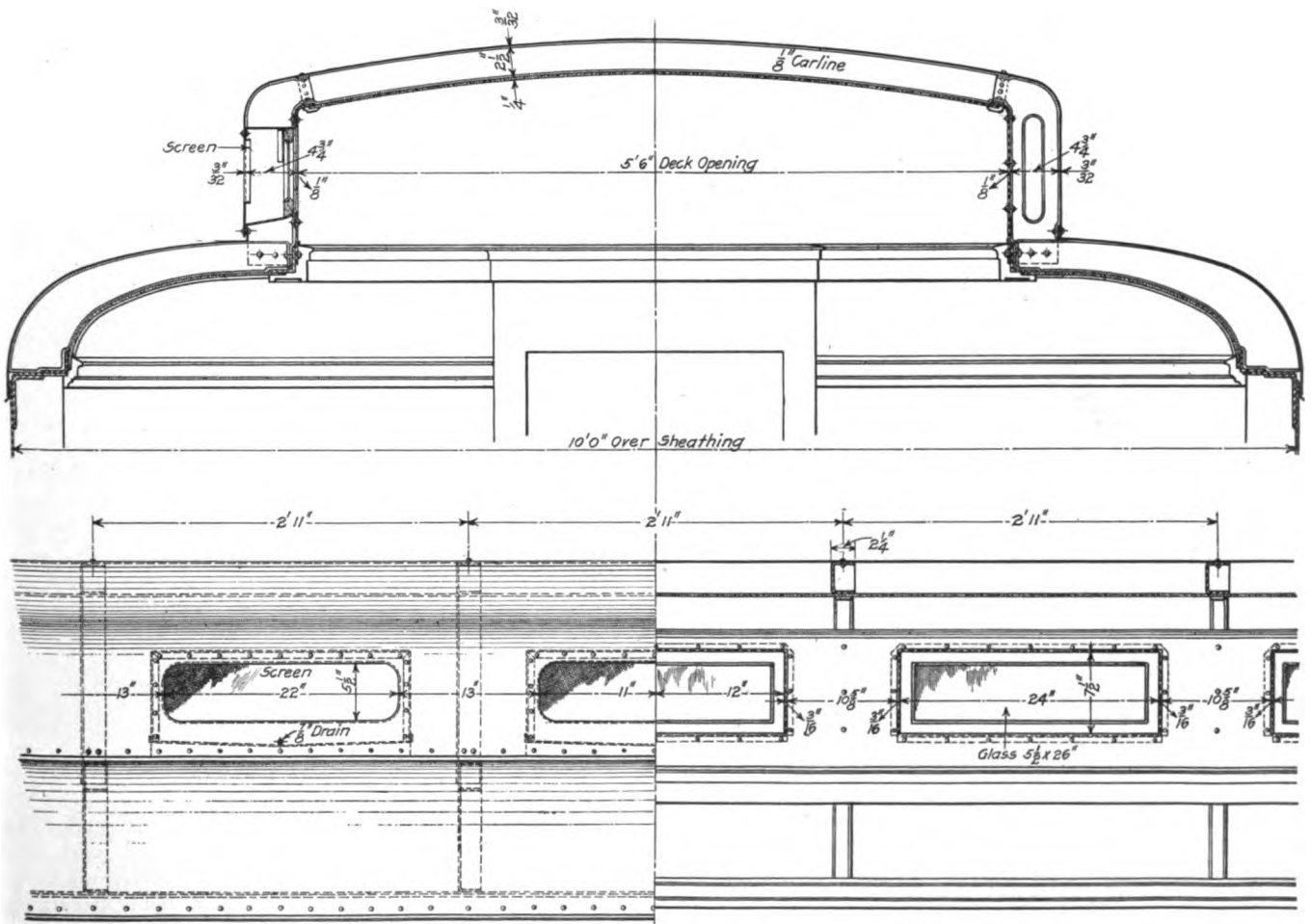

Simple Weather Proof Clere-Story Roof Construction

throughout the length of the deck a combined flashing and frame is provided for each opening which completely encloses the space between the screen and the sash. The remainder of the space between the sheathing and the interior finish of the car is thus closed from communication with the outside air and serves as insulation. The bottom of the window casing slopes outward and toward the middle and drains through a small hole in the outside sheet.

This construction is claimed to make possible a considerable saving in weight as compared with the usual type of clerestory roof.

COTTER AND KEYSEAT DRILL

The machine shown herewith is especially adapted to the drilling of spline and keyseats in shafts, piston rods and locomotive crossheads. It may also be used for drilling and mortising the holes in side rod stubs at one setting. It is manufactured by the Niles-Bement-Pond Co., New York, and is furnished in two sizes, with either one or two heads. The illustration shows the

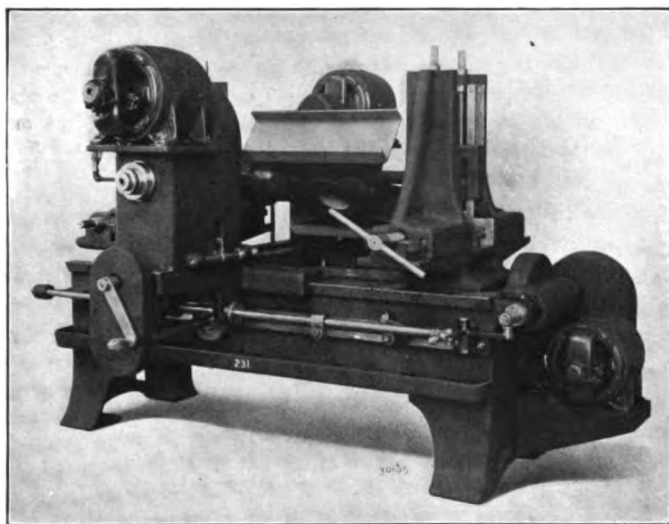

Machine for Drilling Spline and Key Seats

larger size machine with two heads, with a large crosshead set up for drilling the key slot.

The chuck jaws in this machine will take work up to 10 in. in diameter and it has a spline cutting capacity up to 36 in. long, 2½ in. wide and 16 in. deep. For large work the machine may be equipped with sliding centers which will take pieces up to 19 in. in diameter and 42 in. long.

Each spindle is driven by a separate motor, which is mounted on the head. The heads may be moved on the carriage by either hand or power cross-feeds and a reciprocating longitudinal traverse of the carriage is provided on the bed of the machine. This is reversed automatically by means of trips, the location of which is adjustable on the reversing rod, shown in front of the bed of the machine. Variable power feeds are provided on the spindles and an automatic stop throws out the feed at any desired depth of cut. The traverse of the carriage on the bed of the machine is driven by a separate motor, which is so wired in connection with the spindle driving motors that it will be stopped when the latter are shut off.

By using both heads at the same time it is possible to drill slots completely through the work, the two heads cutting from opposite sides. When near the center of the work the automatic stop will throw out the feed on one of the heads, while the other continues to cut through the piece.

As shown in the illustration the machine is provided with universally adjustable chuck jaws, but it may be furnished with them

located at a fixed height where desired. For work which cannot be supported in jaws an adjustable table is supplied.

ADJUSTABLE HUB PLATE

The illustration shows an improvement in the Smith adjustable hub plate, for which patents have recently been granted. This plate is maintained at the proper distance from the hub by means of compressed grease, the adjustment being made by screwing in the grease plug shown on the outside of the wheel hub. The adjustable plate is forced into a recess in the hub, which is 1 in. deep and varies from 2 in. to ¾ in. in width, according to the size of the wheel. It may be applied either by hammering or under a press, about 20 tons being required to press the plate into place. The new feature is the method of preventing the grease from leaking past the plate and relieving the pressure which would affect the adjustment. The plate is beveled to receive a No. 9 gage copper wire, which is placed around the outer and inner edges of the plate, as indicated in the illustration. This wire is soldered so as to be continuous. A No. 24 gage iron

liner holds the copper wire in place as the hub plate is forced outward by the grease pressure. As the hub plate is forced into a bearing in the hub the copper wire assumes a rectangular section, thereby making a more perfect seal. The plate is kept from rotating by six ¼-in. dowel pins screwed into the plate and fitting into holes in the wheel hub.

By the use of this device the lateral may be maintained constant and it may be taken up with comparatively little labor, it being possible to adjust all the wheels in from one to three hours. This eliminates the necessity of dropping the wheels and relining the face of the driving boxes when the lateral becomes too great. By the use of this hub plate much less lining material is required on the face of the

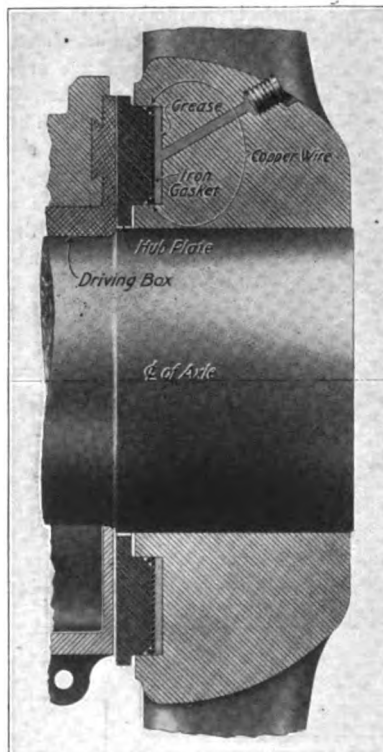

Improved Smith Adjustable Driving Wheel Hub Plate

driving box, inasmuch as the hub plate is ½ in. thick on its outer flange. Excessive wear on the driving box liner is also eliminated as the lateral may be properly maintained and thus prevent pounding, due to the excessive lateral, which many times breaks away the driving box liner. It has also been found unnecessary to reline the boxes between shoppings. The plate can be applied to old as well as new locomotives. The right for the use of the plate is sold by the Smith Locomotive Adjustable Hub Plate Company, Pittsburgh, Kan.

A CORRECTION

In the August number was published an article entitled "Simple Coupler Release Rigging," from which the name of the manufacturer of the device described was inadvertently omitted. The device is the Singlelink release rigging, and is manufactured by the National Railway Devices Company, Chicago.

HIGH COMPRESSION OIL ENGINE

The Nordberg Manufacturing Company, Milwaukee, Wis., now builds a high compression oil engine, in sizes of from 50 to 200 hp., designed to meet a widespread demand for an engine as simple as a slide valve steam engine. There are many small steam plants burning oil, where the fuel totals 2 to 4 lb. per hp. An oil engine delivers the power on .4 to .6 lb. of oil, but nevertheless is worthless to a plant owner unless it is simple and reliable and can be operated by an ordinary mechanic.

The accompanying photographs illustrate the 200 hp., 270 r.p.m. size, Nordberg high compression oil engine. These engines re-

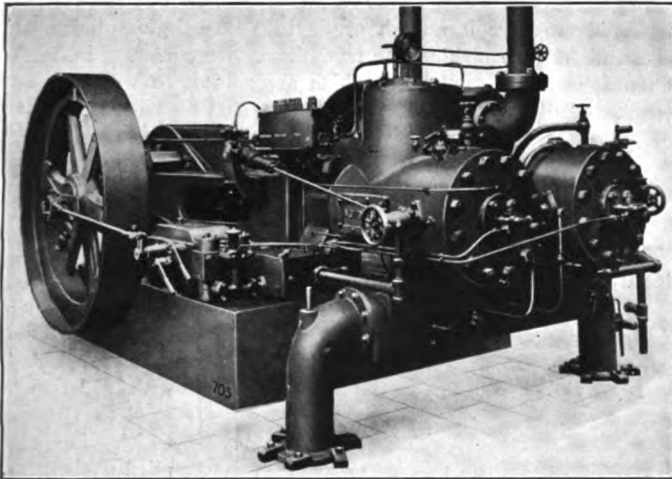

Nordberg 200 hp. High Compression Oil Engine

tion. The head is a simple symmetrical casting and is not subject to cracks due to unequal expansion strains. There are no valves in the head. The only valve on the engine is a piston valve for scavenging air, located above and between the cylinders. One valve controls the scavenging air for the two cylinders. Air is compressed on the crank side of the piston and by-passed to the head end shortly after the uncovering of the exhaust valves. This forces the burnt gases out of the cylinder and fills it with fresh air. Compression and combustion then occur as in any two-cycle engine. The air intake is through the vertical pipes above the engine, and exhaust through the pipes going through the floor.

For the 200 hp. twin engine a special automatic starting arrangement has been designed, simplifying the operation so that the engine may be brought up to speed in less than a minute.

The fuel pumps run in a bath of lubricating oil. The oil is drawn from the storage tank to a small strainer box located to the right and behind the pumps, from which it flows to the main fuel pumps. A small heating coil, through which heated jacket water circulates, is contained in the main oil compartment of the strainer box to insure free flow of very viscous oils. The pumps are operated by cams driven by an eccentric and deliver a quantity of oil in excess of that required for maximum load, the governor acting to by-pass more or less of the fuel, depending on the load obtaining. The by-passed oil is discharged through the sight glass and gives the operator a quick check on the working of each of the pumps. The governor is of the fly-wheel design and gives a regulation of 2 per cent. from no load to full load. From the fuel pumps the oil is discharged through small pipes to the atomizer heads bolted to the main cylinder heads.

The lubricating system of the engines is entirely automatic, oil being fed from a central pump driven from the scavenging valve eccentric. Cylinder oil is pumped to the scavenging air valve and to the main cylinders. Bearing oil is pumped to all main bearings, to the crosshead pins through trombone oilers and to all auxiliary bearings. The cranks are enclosed by polished iron guards and the oil accumulates in the crank case from various parts of the engine and is drained to a filter and returned to the lubricator.

BALL JOINT CONNECTION FOR MAIN RESERVOIRS

The breakage of air pipes where they screw into the main reservoir on locomotives has always been a source of annoyance

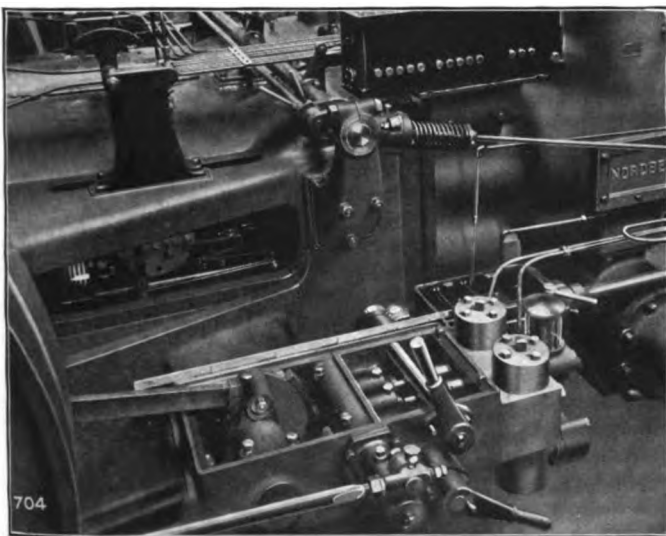

Fuel Injection Pumps, Strainer Tank and Air Starting Gear

atomizing head. The elimination of the high pressure compressor with its intercoolers simplifies the installation in small plants, for which these engines are designed.

The engine is of the two-cycle design, and all valves, cams, springs and valve gear have been eliminated, contributing further to the item of simplicity and ease of attendance and inspec-

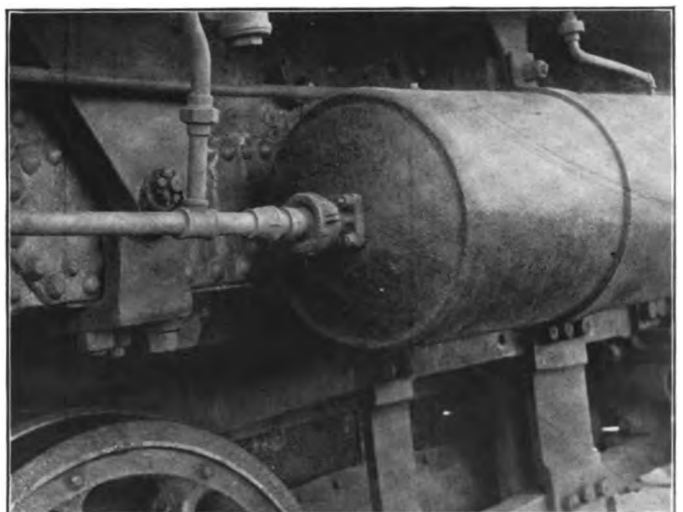

Flexible Joint with Flange Connection for Main Reservoirs and expense, and to overcome this special brackets have been designed and are in quite general use to rigidly support the reser-

voir. The greater part of the trouble is caused by vibration while the engine is running and in order to eliminate such breakages the Barco Brass & Joint Company, Chicago, has developed the flexible joint shown in the engraving. This connection is made with a flange attachment to the reservoir which, it is claimed, gives better service than when a nipple is used. This type of reservoir connection has now been in successful service for about three years.

ELECTRIC HAND LANTERN

An electric lantern of substantial construction has recently been placed on the market by the Delta Electric Company, Marion, Ind. It is designed to withstand severe service, such as imposed upon the various classes of oil lanterns now in general commercial use. The case is formed from cold rolled steel, ribbed to add strength, and the bottom is provided with a one-half-inch flange extending completely around the lantern. No solder has been used in the construction and all parts are thor-

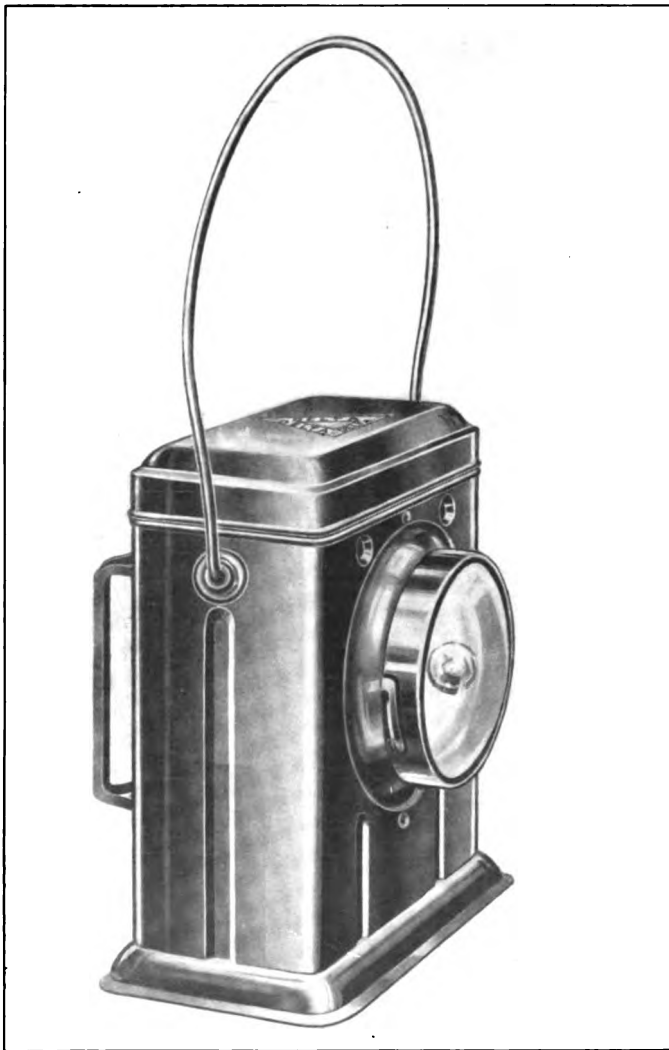

Delta Electric Lantern.

oughly riveted together. It is provided with an extra large drop bale handle, suitable for throwing over the arm and a grip handle is attached to the back, which may be folded flush with the back of the lantern when not in use.

The lantern is fitted with a three-volt tungsten bulb and lighted by batteries which will run from 100 to 150 hours in actual use.

The batteries are connected to the lamp by flexible wires which are secured with binding screws and may be replaced when worn. The reflector case is drawn out of the body of the lantern, thus giving protection to the vital parts of the lantern, the reflector, bulb and contacts. The reflector is drawn from sheet phosphor bronze and has three coats of heavy silver, polished to a mirror finish. A concave-convex lens, 3 in. in diameter is placed in front of the bulb. The switch is located in the back of the lantern in a convenient and well protected place, it being so arranged that it does not project beyond the surface of the lantern.

The light is thrown evenly through a hemi-sphere so that if the lantern is hung on a wall it will throw light on all sides of the room. It may be provided with a spot light reflector if desired. Owing to the absence of solder in the construction of the case, it is possible to give it a high grade baked semi-gloss finish of black enamel with nickle plate trimmings. It stands 7¼ in. high and weighs 16 oz. All parts which are subject to wear are so constructed that it is possible to replace them at a minimum cost.

JOURNAL JACK

The accompanying illustration shows a journal jack, recently placed on the market by the Parsons Metal Products Company,

Indianapolis, Ind. This jack is provided with a long pawl as shown, which is applied to the projection of the car wheel rim, thus keeping the wheel on the track while the box is being lifted for the application of a new brass. This jack is made entirely of steel, and weighs 29 lb. complete. It is 10½ in. high when closed, and 15½ in. high when extended to the limit. It has a capacity of 25 to 30 tons. Its construction is simple, only nine separate parts being used.

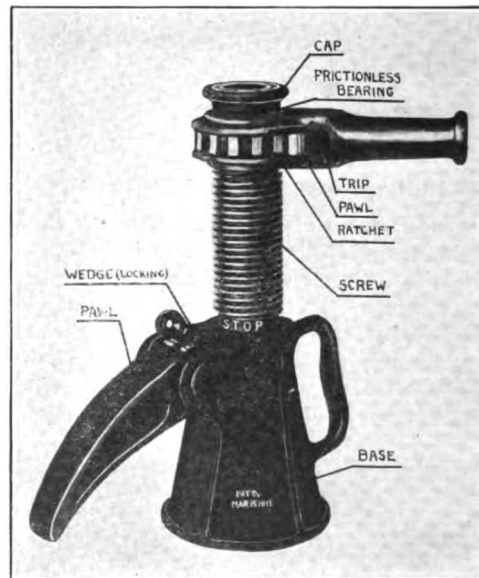

Parsons Journal Jack

It has a capacity of 25 to 30 tons. Its construction is simple, only nine separate parts being used.

METAL BAND SAW

The illustration shows a metal cutting band saw which has recently been placed on the market. It is designed to cut off stock from ⅛ in. to 8 in. in diameter, and will handle 8-in. I-beams or square sections. The machine is of simple construction throughout and may be operated by unskilled labor.

The table is 26 in. high, and is stationary, the saw being moved to the work. The frame carrying the saw wheels and driving mechanism is mounted on guide bars upon which it slides, and may be operated either by hand or automatic gravity feed, the pressure being varied by the number of weights hung on the operating lever. The saw guide is conveniently located and easy to adjust. The tightening of the blade is accomplished by the hand wheel shown on top of the machine. When motor driven, the motor is mounted on the frame of the saw, as shown

in the illustration, making the machine entirely self-contained. Light material, such as tubing, metal moldings, etc., are cut very rapidly and accurately. For special work requiring a flat

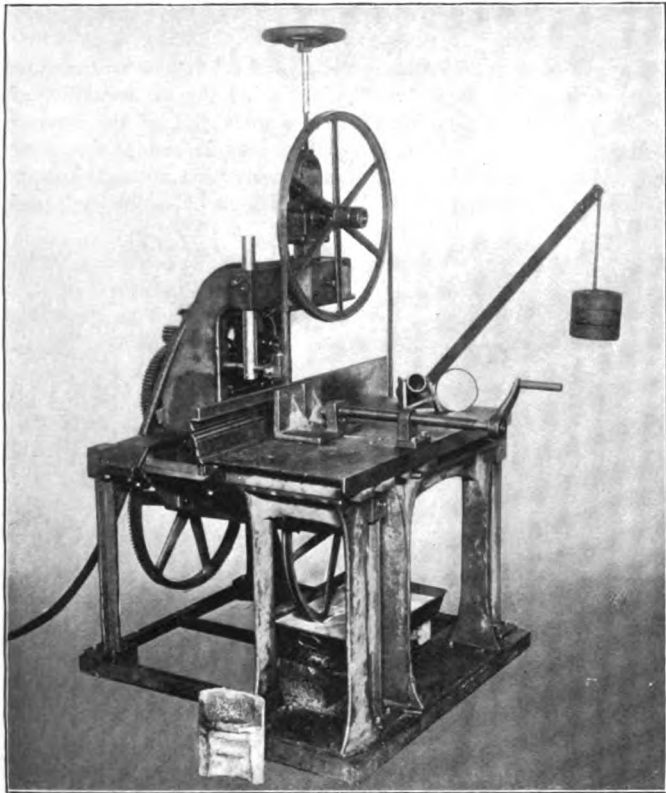

Metal Cutting Band Saw

table the back may be removed. The saw is manufactured by H. C. Williamson, 1840 West Lake street, Chicago.

DOUBLE ACTION FORCE FEED CYLINDER LUBRICATOR

The force feed lubricator shown in the drawings is designed for use in lubricating locomotive cylinders. It is of the double

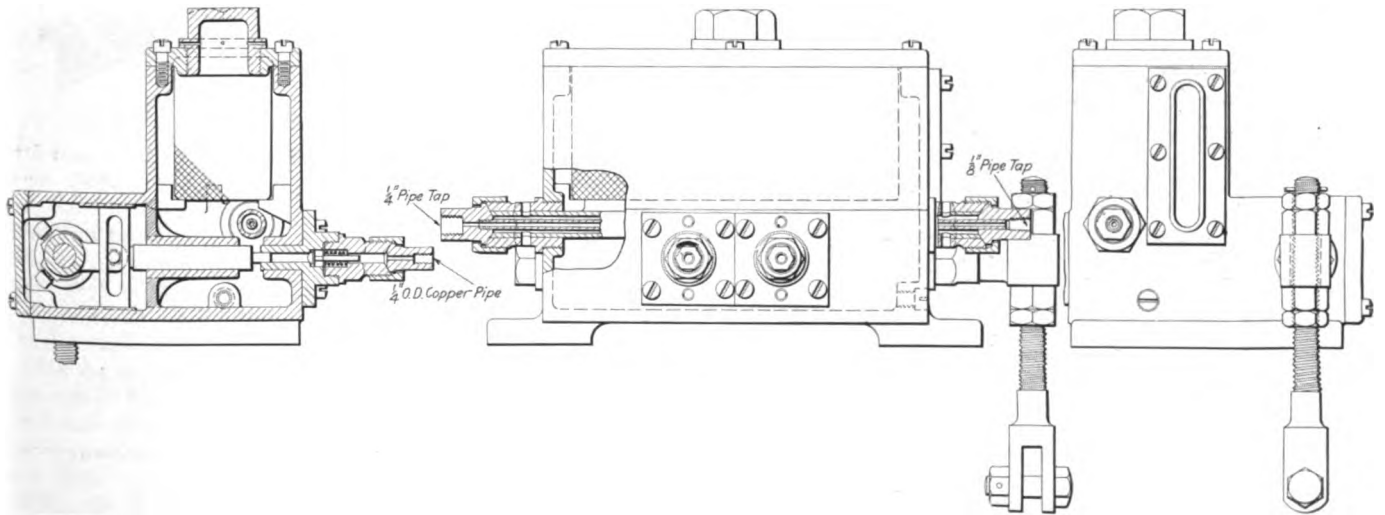

Nathan Force Feed Cylinder Lubricator

action directly operated type and is being manufactured by the Nathan Manufacturing Company, New York. By referring to the detail drawing of the lubricator it will be

seen that it is directly operated without the use of a ratchet. The lever attachment to the lubricator is designed to be connected in any suitable manner with a reciprocating part of the engine, the length of the arm being adjustable to suit the amplitude of the motion. The oscillating shaft to which the lever is attached is provided with arms in the lubricator which are pin connected to slotted crossheads on the ends of the pump plunger, the arrange-

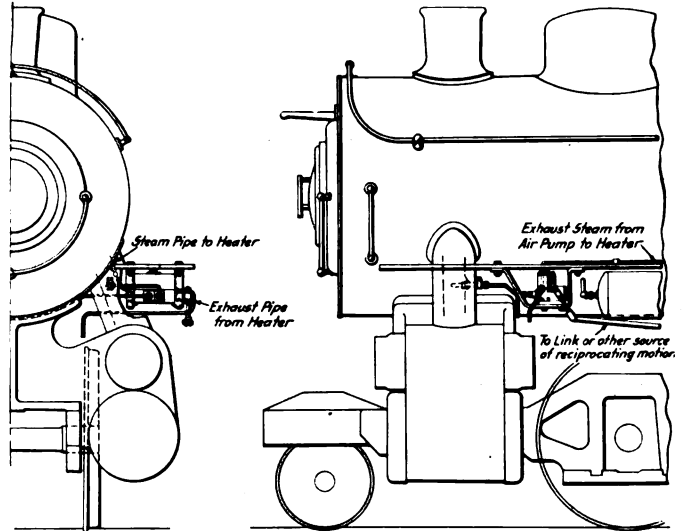

Location of Force Feed Lubricator on the Locomotive

ment being such that for each complete cycle or revolution of the engine two complete cycles of the pump plungers are produced. Oil is thus forced into the steam passages twice during each revolution by the use of but one plunger for each cylinder. The plunger is shown in the drawing at the end of its forcing stroke. At the other end of the stroke it is drawn back from the end of the barrel, thus allowing the oil to enter directly from the reservoir. A spring operated ball seat check valve at the end of the plunger barrel prevents the back flow of oil from the lubricator pipe. These valves and the plunger barrels are readily accessible by the removal of special threaded fittings on the front of the lubricator, and the barrels may be renewed.

The oil reservoir contains a small exhaust steam heater of a novel design. Steam from the air pump exhaust passes through a small pipe extending from end to end of the reservoir, the condensation being carried from the lubricator to any convenient

point under the engine. Surrounding the steam pipe is a larger pipe with openings to the atmosphere at either end of the reservoir, thus providing for a circulation of air about the steam pipe.

The oil in the lubricator reservoir is thus warmed, but without danger of overheating.

CONSTANT CURRENT ELECTRIC WELDER

The electric welding equipment shown herewith has recently been developed by the Lincoln Electric Company, Cleveland, Ohio, with a view to reducing the cost of power consumption and increasing the simplicity of operation. Special windings in the generator, on which patents are pending, automatically regulate the voltage to the exact requirements of the arc, thus providing a predetermined current output which is practically constant irrespective of the varying resistance in the arc.

The equipment is built in units, each of sufficient capacity to meet the requirements of one operator. Where more work is done than can be handled by one operator more units are added to the plant. The equipment is thus always operating at practically full capacity and therefore at maximum efficiency, and the investment is closely adjusted to the amount of work to be handled. The automatic voltage regulation greatly reduces the amount of power required; with the exception of work on large steel castings or where heavy cutting is to be done, the equip-

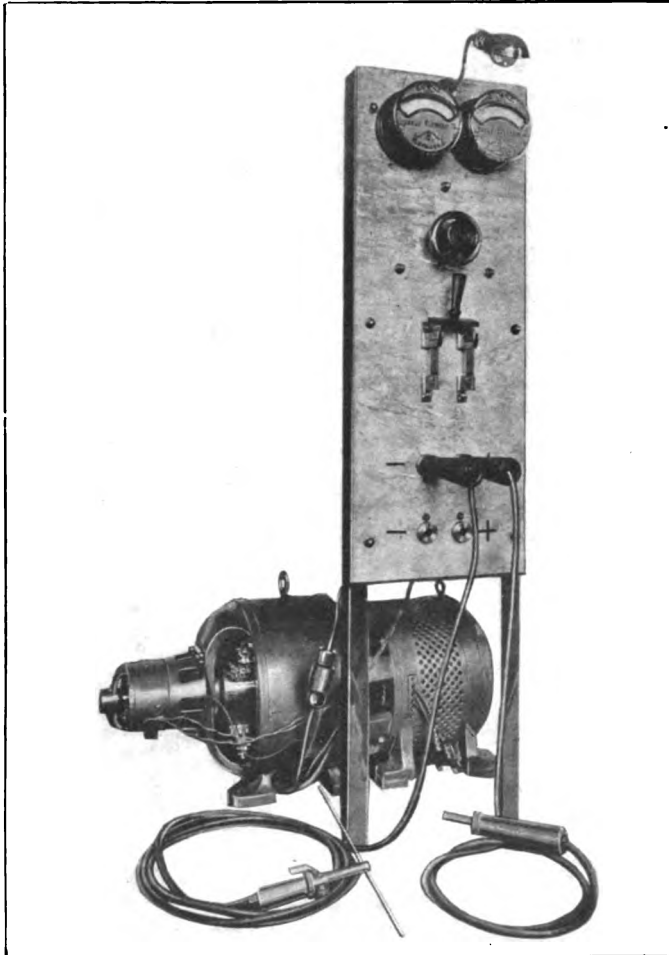

Lincoln Arc Welder.

ment may be operated on any power line which will carry a 10 h.p. motor. The equipment is very flexible in operation as any number of units may be operated either individually or in parallel. The operator may, without the services of an electrician, connect three 150-ampere plants in parallel and secure 450 amperes for heavy carbon electrode work and may separate the units again in a few minutes. The positive terminal, shown at the right, is connected to the piece to be welded. On the end of

the negative connector is shown the electrode holder with a metal electrode in place.

WATER GLASS GUARD

Changes have recently been made in the Babcock water glass guard with a view to materially increasing the serviceability of the device by providing for effective illumination of the interior at night. This water glass guard has been in service for some time and the general features of its construction are well known. It consists of two parts: the back, which includes the ends and

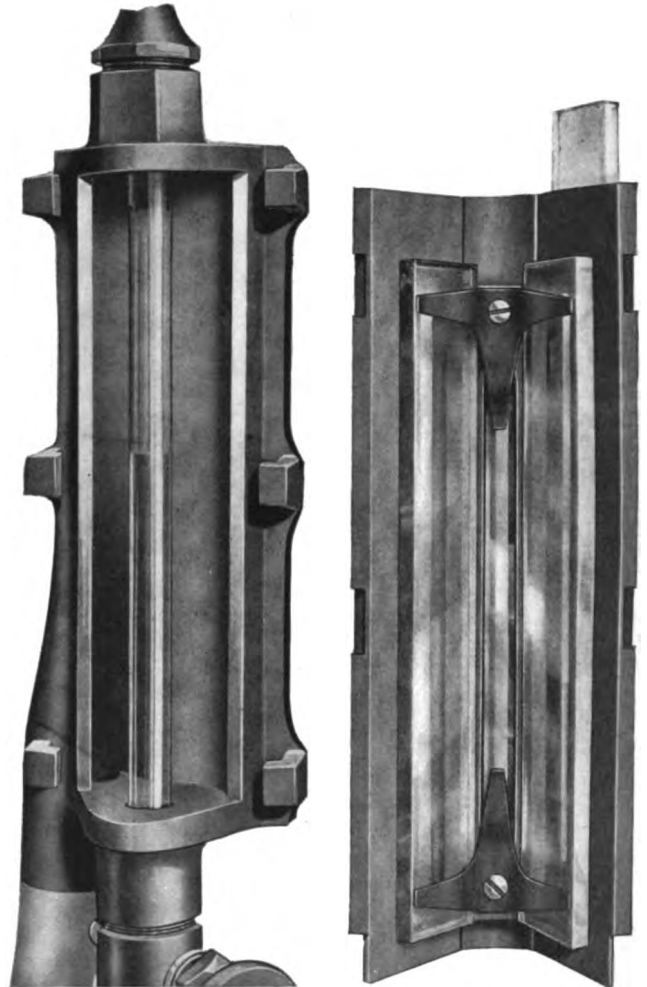

Water Glass Guard with Slot for Illumination.

packing glands, and is provided with an outlet at the bottom for steam and broken glass, and the removable front, which contains the sight glasses. The improvements consist in the redesign of the front casing to include a narrow slot at the apex of the angle between the faces containing the sight glasses. In front of this slot is placed the gage lamp and the light thus admitted thoroughly illuminates the interior of the guard, clearly indicating the water level in the gage glass. This construction eliminates the effect of reflection from the sight glasses which may be very annoying where the light must enter the guard through the sight glasses. This water glass guard is manufactured by the American Car & Ship Hardware Company, New Castle, Pa.

THE GREATEST AVAILABLE WATER POWER.—Great Falls, Mont., claims the greatest available water power on the continent. There are now operating 75,000 hp., and 100,000 hp. more is being developed. At the lowest average flow of water the available supply is 350,000 hp.

NEWS DEPARTMENT

The shop of the Northern Pacific at Livingston, Mont., is running full time for the first time since 1909.

A fire on August 2 destroyed the storehouse of the Chicago Great Western at Oelwein, Iowa, and most of the contents. The estimated loss is \$75,000. Plans are now being prepared for a new structure.

About 150 machinists, boilermakers and sheet metal workers employed by the Kansas City Terminal Railway went on strike last week on account of a controversy with the company regarding the scale of wages and the employment of non-union labor.

On July 19 a car repair shed of the Atchison, Topeka & Santa Fe at Argentine, Kan., was destroyed by fire. There were also 24 cars destroyed and 12 cars damaged. The total estimated loss will not exceed \$50,000. The cause of the fire is unknown.

The Canadian Department of Labor has appointed a board under the Industrial Disputes Act to deal with a difference which has arisen between the Canadian Northern and two brotherhoods, those of the locomotive enginemen and the firemen. The men have asked that the conditions under which they work in the East be raised to the level of conditions prevailing on the Western lines.

According to newspaper reports from Seattle, Frank Waterhouse & Co., of that city, have chartered seven vessels to transport 7,500 freight cars to Vladivostok for delivery to the Russian government. Six thousand cars are to be shipped from New York City through the Panama Canal and 1,500 are to be shipped from Puget Sound ports. The average capacity of the vessels chartered is 150 cars for each trip.

The Southern Railway has finished its new coal handling plant at Charleston, S. C., and it will be put in operation September 1. It will have a capacity of 40 cars an hour, which is as fast as any ship now in the coal carrying trade can take it. In preparation for a greatly increased movement of coal to Charleston, the Southern has provided storage room for 400 cars.

On July 1 the Canadian government took over the operation of the Transcona roundhouse and roundhouses, shops, and work pertaining to the motive power department of the Grand Trunk Pacific, between Winnipeg and Westfort, Ont. The supervision of all employees engaged on this section of the road will be in the hands of the Grand Trunk Pacific officers until such time as the government appoints its own staff or takes over the present staff.

The safety bureau of the Union Pacific reports that during the year ending June 30, 1915, the road carried 4,550,949 passengers without a fatality to a passenger. Less than half as many employees of the road were killed during the year as in the fiscal year ending June 30, 1913, which was the last year before the bureau of safety was organized. In 1915 28 employees were killed, as compared with 59 in 1913. In 1915 4,537 employees were injured, and in 1913 6,097 were injured. In 1915 229 passengers were injured, and in 1913 333 passengers were injured.

NEW LOCOMOTIVE INSPECTION RULES

In accordance with the Act of Congress, passed last March, to extend the authority of the Interstate Commerce Commission over the inspection and testing of the entire steam locomotive and tender, rules and instructions have just been formulated by the Division of Locomotive Boiler Inspection. These were considered at a conference with a railroad committee on August 23. The rules are set forth in a 15-page pamphlet and cover ash pans, brake and signal equipment, cabs, warning signals and sanders, draw gear and draft gear, driving gear, lights, running gear, tenders and throttle and reversing gear.

THE MUTUAL MAGAZINE

President Fairfax Harrison, of the Southern Railway, signaled the close of the company's fiscal year by sending to all officers and employees the following message: "We are closing today a fiscal year which has been full of anxiety and difficulty, but through team work and loyal self-sacrifices and effort by the entire organization, we have come out of it sound and full of courage for the future. This result has not been due to any one man or to any group of men, but to the co-operation of every man who has recognized the problem and given us in our common duty the best that was in him. I send my personal thanks then to everyone of you. The fight is not yet over, but the spirit of the past ten months is bound to see us through. Meanwhile, I want you to know my pride in you and in what has been done already."

PANAMA CANAL 50 YEARS AHEAD OF TIME

"We have recently completed the Panama Canal, a work which it would have been better to have left for 50 years rather than to have put it through with the speed with which the government has done it, because we find that we are not prepared to handle the questions of transportation arising by virtue of the completion of the canal at this time, bearing in mind the fact that the cities in the West, tributary to the coast, east as far as the eastern section of Montana, have a population of only 7,000,000 people. Last year the freight shipments from the Atlantic seaboard to Western territory amounted to 170 train loads, and shipments eastbound about half that amount."—F. R. Hanlon, traffic manager of the port of Seattle, Wash., address before convention of United Yardmasters' Association at Seattle.

MEETINGS AND CONVENTIONS

Chief Interchange Car Inspectors and Car Foremen.—The seventeenth annual convention of the Chief Interchange Car Inspectors' and Car Foremen's Association of America will be held at Murphy's hotel, Richmond, Va., September 14-16. This is the first time that the meeting of the association has been held so far south, and it is suggested that this will offer a good opportunity for southern railroad men to attend.

International Association for the Prevention of Smoke.—The tenth annual convention of the International Association for the Prevention of Smoke will be held at Hotel Sinton, Cincinnati, Ohio, September 8, 9 and 10. Of the papers to be presented those which will be of special interest to railroads are the following: Value of Publicity in Smoke Abatement Work and Methods of Obtaining It; Smokeless Locomotive Operation Without Special Apparatus; Various Methods of Eliminating Smoke from Roundhouses in Chicago; How Smokeless

Operation of Locomotives Was Obtained in Washington, D. C.; What the Railroads Have Done to Abate Smoke in Cincinnati, and Enforcing a Smoke Ordinance.

Foundry and Machine Exhibition.—The Foundry and Machine Exhibition will be held on Young's Million Dollar Pier, Atlantic City, from September 25 to October 1. This is the first time in three years that the exhibit has been held in the east, and there will be a keen interest in it in that section particularly. Business conditions in this line are improving everywhere, and the attendance promises to be large and the exhibit a profitable one for the exhibitors. From all indications, therefore, the exhibit should be as successful as the one in Chicago last year. C. E. Hoyt, the secretary, has opened an office in the Bourse, Philadelphia, for the convenience of exhibitors, and others desiring information or help of any kind.

The Traveling Engineers' Association.—The twenty-third annual convention of the Traveling Engineers' Association will be held at the Hotel Sherman, Chicago, commencing at 10 a. m., Tuesday, September 7, and continuing four days. The subjects to be discussed are as follows: "What Effect Does the Mechanical Placing of Fuel in Fireboxes and Lubricating of Locomotives Have on the Cost of Operation?" W. L. Robinson, chairman; "Recommended Practices for the Employment and Training of New Men for Firemen," L. R. Pyle, chairman; "The Advantages of the Use of Superheaters, Brick Arches and Other Modern Appliances on Large Engines, Especially Those of the Mallet Type," J. E. Ingling, chairman; "How Can the Road Foreman of Engines Improve the Handling of the Air Brakes on Our Modern Trains?" C. M. Kidd, chairman; "Difficulties Accompanying Prevention of Dense Black Smoke and its Relation to Cost of Fuel and Locomotive Repairs," Martin Whelan, chairman; "The Electro-Pneumatic Brake," W. V. Turner; "The Effect of Properly Designed Valve Gear on Locomotive Fuel Economy and Operating," W. E. Preston; "Scientific Train Loading, Tonnage Rating, the Best Method to Obtain Maximum Tonnage Haul for the Engine Over the Entire Division, Taking Into Consideration the Grades at Different Points on the Division," O. S. Beyer, Jr.

The following list gives names of secretaries, dates of next or regular meetings, and places of meeting of mechanical associations:

AIR BRAKE ASSOCIATION.—F. M. Nellis, 53 State St., Boston, Mass.

AMERICAN RAILROAD MASTER TINNERS, COPPERSMITHS AND PIPEFITTERS' ASSOCIATION.—W. E. Jones, C. & N. W., 3814 Fulton St., Chicago.

AMERICAN RAILWAY MASTER MECHANICS' ASSOCIATION.—J. W. Taylor, Karpen Building, Chicago.

AMERICAN RAILWAY TOOL FOREMEN'S ASSOCIATION.—Owen D. Kinsey, Illinois Central, Chicago.

AMERICAN SOCIETY FOR TESTING MATERIALS.—Prof. E. Marburg, University of Pennsylvania, Philadelphia, Pa.

AMERICAN SOCIETY OF MECHANICAL ENGINEERS.—Calvin W. Rice, 29 W. Thirty-ninth St., New York. Annual meeting, December 7-10, 1915, New York.

ASSOCIATION OF RAILWAY ELECTRICAL ENGINEERS.—Joseph A. Andreucetti, C. & N. W., Room 411, C. & N. W. Station, Chicago. Annual meeting, October, 1915.

CAR FOREMEN'S ASSOCIATION OF CHICAGO.—Aaron Kline, 841 North Fiftieth Court, Chicago. Second Monday in month, except July and August, Lytton Building, Chicago.

CHIEF INTERCHANGE CAR INSPECTORS' AND CAR FOREMAN'S ASSOCIATION.—S. Skidmore, 946 Richmond St., Cincinnati, Ohio. Annual meeting, September 14-16, 1915, Richmond, Va.

INTERNATIONAL RAILWAY FUEL ASSOCIATION.—C. G. Hall, 922 McCormick Building, Chicago.

INTERNATIONAL RAILWAY GENERAL FOREMEN'S ASSOCIATION.—William Hall, 1126 W. Broadway, Winona, Minn.

INTERNATIONAL RAILROAD MASTER BLACKSMITHS' ASSOCIATION.—A. L. Woodworth, Lima, Ohio.

MASTER BOILER MAKERS' ASSOCIATION.—Henry D. Vought, 95 Liberty St., New York.

MASTER CAR BUILDERS' ASSOCIATION.—J. W. Taylor, Karpen Building, Chicago.

MASTER CAR AND LOCOMOTIVE PAINTERS' ASSOCIATION OF U. S. AND CANADA.—A. P. Dane, B. & M., Reading, Mass. Convention, September 14-17, 1915, Detroit, Mich.

NIAGARA FRONTIER CAR MEN'S ASSOCIATION.—E. Frankenberger, 623 Brisbane Building, Buffalo, N. Y. Meetings monthly.

RAILWAY STOREKEEPERS' ASSOCIATION.—J. P. Murphy, Box C, Collinwood, Ohio.

TRAVELING ENGINEERS' ASSOCIATION.—W. O. Thompson, N. Y. C. R. R., East Buffalo, N. Y. Convention, September 7-10, 1915, Hotel Sherman, Chicago, Ill.

PERSONALS

It is our desire to make these columns cover as completely as possible all the changes that take place in the mechanical departments of the railways of this country, and we shall greatly appreciate any assistance that our readers may give us in helping to bring this about.

GENERAL

J. A. MACRAE, who has been appointed mechanical engineer of the Louisville & Nashville, with headquarters at Louisville, Ky., was educated at the University of Illinois, where he took



J. A. MacRae

a course in mechanical engineering, graduating in 1896. The following year he began railway work as a draftsman in the office of the mechanical engineer of the Chicago & North Western, remaining with that company until 1899, when he entered the service of the New York Central & Hudson River. There, until 1904, he was engaged in special work and as draftsman at Albany and at New York City. From 1904 to 1906 he was mechanical engineer of the Boston & Albany, at Boston. Then until January, 1915, he was mechanical engineer

of the Michigan Central at Detroit, Mich., and now becomes mechanical engineer of the Louisville & Nashville, with headquarters at Louisville, Ky., as above noted.

SHOP AND ENGINE HOUSE

J. A. MILER has been appointed locomotive foreman of the Grand Trunk Pacific at Endako, B. C., succeeding G. H. Laycock, transferred.

JOHN McREA, heretofore shop foreman of the Canadian Pacific at Kamloops, B. C., has been appointed locomotive foreman at North Bend, B. C., succeeding C. Brown.

PURCHASING AND STOREKEEPING

R. A. JACOBS has been appointed traveling storekeeper of the St. Louis & San Francisco, succeeding E. J. Price, promoted.

H. M. POWELL, recently general storekeeper of the St. Louis & San Francisco, has been appointed to the newly-created position of supervisor of material and supplies of the Texas & Pacific, with headquarters at Marshall, Tex.

EDWARD J. PRICE has been appointed general storekeeper of the St. Louis & San Francisco, with headquarters at Springfield, Mo., succeeding H. M. Powell. Mr. Price was born at Marion, Ill., on June 28, 1870. He was educated in the common and night schools and entered railway service on September 21, 1888, as messenger boy with the Union Pacific at Kansas City, Mo. He left the Union Pacific in June, 1891, and went to the Atchison, Topeka & Santa Fe, which road he remained with until November, 1913, when he was appointed traveling storekeeper of the St. Louis & San Francisco, from which position he is now promoted, as above noted.

SUPPLY TRADE NOTES

G. F. Riddell, superintendent of the Chicago Heights Works of the Inland Steel Company, died of heart failure at his home in Chicago on August 12.

The Canadian Car & Foundry Company, which has been working on an \$83,000,000 order for shells for some time, is now reported to have received an additional order for \$71,000,000.

The Keuffel & Esser Company, New York, has been awarded three grand prizes at the Panama-Pacific Exposition at San Francisco, for its exhibit of drawing instruments and slide rules, surveying instruments and telescopic sights and periscopes, respectively.

W. K. Millsapps, southwestern representative of the Grip Nut Company, Chicago, with headquarters at Houston, Tex., died on August 6, at Houston. Prior to his connection with the Grip Nut Company he was for several years general storekeeper of the Sunset Central lines.

Lewis Littlepage Holladay and Henry Negstad, consulting engineers, have formed a company under the corporate name of Holladay, Negstad & Co., and will specialize in the field of power plants, utilities and industries. They will be located at 109 North Dearborn street, Chicago.

Charles B. Ellis, assistant to J. L. Replogle, vice-president and general manager of the American Vanadium Company, with office in New York, has become associated with the Bartlett-Hayward Company, Baltimore. Mr. Ellis was for many years with the Cambria Steel Company.

Thomas Cantley, vice-president of the Nova Scotia Steel & Coal Company, Halifax, N. S., has been elected president of that company, succeeding R. E. Harris, who has resigned to become a member of the Nova Scotia Supreme Court. The vice-presidents of the company now are J. D. McGregor and D. W. Ross.

M. A. Evans, western sales manager of the Railway Appliances Company, Chicago, at the time that company was bought by the Q. & C. Company, New York, and with the latter company temporarily during the reorganization period, has resigned. Mr. Evans will take a short vacation before returning to the railway supply business.

The Spray Manufacturing Company, Boston, Mass., recently incorporated to construct spray cooling systems, gas scrubbers, odor and fume condensers, etc., has changed its name to the American Spray Company, as it will engage in general engineering work involved in the use of spray systems. The management of the company remains unchanged.

Robert M. Smith, assistant mechanical engineer of the Acme Supply Company, Chicago, has been appointed mechanical engineer. Mr. Smith was formerly chief car draftsman for the Illinois Central and went to the Acme Supply Company last January as inspector. In March he was appointed assistant mechanical engineer, and on August 1 mechanical engineer.

The Pratt & Whitney Company has opened an office and showroom at 16 Fremont street, San Francisco, in charge of S. G. Eastman, formerly manager of the Chicago office. A large stock of Pratt & Whitney machinery, small tools and gages will be carried for the convenience of customers, and the office has been appointed agent for the entire Niles-Bement-Pond line of machine tools, cranes, steam hammers, etc.

The Mesta Machine Company, Pittsburgh, Pa., has recently received an order from James B. Ladd, consulting engineer, Philadelphia, for a 1,500 hp. mill engine for the Broken Hill Proprietaries Company, Ltd., New Castle, N. S. W. The engine is for rolling mill service, and is to be of the heavy-duty tandem compound Corliss valve type. This engine, when installed, will make the fourth unit that the Mesta Machine Company has built for the Broken Hill Proprietaries Company.

Joseph T. Ryerson & Son, Chicago, have recently completed a new warehouse on Westside avenue, Jersey City, N. J. The company has maintained an office at 30 Church street, New York, and a warehouse at Boonton for some time. The new plant in Jersey City will put it in a much stronger position for handling its iron, steel and machinery business in the New York district and the East in general. The warehouse is located on a ten-acre site at the junction of the Hackensack river and Newark bay, thus affording facilities for making water shipments to all parts of New York harbor and adjacent waters. The building is 350 ft. by 250 ft., and covers a ground area of 87,500 sq. ft.

The Bethlehem Steel Company has purchased the plant of the Detrick & Harvey Machine Company, Baltimore, Md. The directors of the latter have elected the following officers: A. D. Mixsell, president; W. F. Roberts, vice-president; J. W. Neidhardt, vice-president and general manager; B. F. Jones, secretary and treasurer, and F. A. Shick, auditor. Mr. Neidhardt, as vice-president and general manager, will be the local representative of the Detrick & Harvey Company, at Baltimore. This company was formed in 1884 by John S. Detrick and Alexander Harvey, and these two occupied the positions of president and secretary and treasurer, respectively, until Mr. Harvey's death last November, when Curran W. Harvey, his son, succeeded his father. The company manufactures planers, horizontal drilling and boring machines, vertical boring and turning mills and special machinery. It will continue to engage in this business.

Bertram Smith, who has been in the storage battery business for the past 15 years, has been appointed manager of the Detroit office of the Edison Storage Battery Company, Orange, N. J. About a year and a half ago Mr. Smith became assistant manager of the Edison Storage Battery Supply Company, of San Francisco, Cal., the distributor for the Edison Nickel-Iron-Alkaline Battery on the Pacific Coast. Directly previous to his connection with the Edison Company he was manager of the battery department in the Chicago branch of the United States Light & Heating Co. He was formerly secretary and treasurer of the National Battery Company, of Buffalo, until its consolidation with the United States Light & Heating Co.

Edward A. Everett, formerly signal engineer of the Michigan Central, has opened an office at 50 Church street, New York, for the sale of railway supplies and signal material. He represents the Hobart-Allfree Company, Chicago, derailleurs and car replacers; E. J. Clark, Philadelphia, Pa., T. C. Cypress Trunking and Capping; the National Concrete Machinery Company, Madison, Wis., concrete fence post machinery and supplies; the Detroit Twist Drill Company, Detroit, Mich., high-speed bonding drills; the J. Frederick Schroeder Air Felt Company, Newark, N. J., high-grade air felt used in refrigerator car construction, steam pipe covering and as a cushion under relays and electrical apparatus; the Cincinnati Electrical Tool Company, Cincinnati, Ohio, portable electric drills, grinders and reamers; the Keller Pneumatic Tool Company, pneumatic drills, hammers, riveters and chippers; the Reliable Electric Company, Chicago, signal, telephone and telegraph specialties. Mr. Everett also has charge of the sales of the electric release train annunciator, which is one of his patents and which has been sold for several years by the Railroad Supply Company, Chicago. He also has a line of copper clad and bond wires and high strength non-corrosive bond wire.

CATALOGS

PIPE ACCESSORIES.—The William Powell Company, Cincinnati, Ohio, has issued a booklet relative to the company's line of oil and air vents, expansion joints, valves and other accessories for oil wells and refineries.

SAND DRYERS.—The Roberts & Schaefer Company, Chicago, has issued Bulletin No. 30, illustrating and describing the "Beamer" patent steam sand dryer, made by that company for drying sand for locomotive use.

POWER TRANSMISSION MACHINERY.—The Mesta Machine Company, Pittsburgh, Pa., has issued Bulletin Ka, containing a horse-power chart for determining the variables for rotating parts transmitting power, such as gears, pulleys, rope wheels, etc.

POWER HAMMERS.—Beaudry & Co., Boston, Mass., have recently issued a booklet relative to the Beaudry Champion and Peerless power hammers, respectively. The booklet describes the hammers in detail and contains tables of sizes and dimensions.

BALL BEARINGS.—The S. K. F. Ball Bearing Company, New York, has recently issued a very attractive booklet relative to the economies of the light car in electric street railway service and the saving to be obtained by the use of ball-bearing journals on such cars.

VERTICAL OIL ENGINES.—This is the title of Bulletin No. 501 recently issued by the National Transit Company, department of machinery, Oil City, Pa. The booklet deals particularly with the type VT-13, two-cycle, single cylinder, vertical oil engines made by this company and contains detailed descriptions of the machine itself and its parts.

SPARK ARRESTER.—Mudge & Co., Chicago, Ill., have recently issued a folder describing the advantages of the Mudge-Slater Front End Spark Arrester, calling attention to its many advantages over the usual form of front-end arrangement, stating that the fire loss on one road equipped with this device has been reduced from \$100,000 to about \$15,000 a year.

UNIONS.—The Jefferson Union Company, Lexington, Mass., has issued a catalogue describing the Jefferson unions of various types. The booklet contains views of the different kinds of unions and shows for what purposes they are made. The patented feature of this company's product is the brass seat ring, placed in a recess away from the runway of the fitting.

SAND-BLAST APPARATUS.—The Mott Sand Blast Manufacturing Company, New York, has issued four folders dealing with the following sand-blast apparatus which it manufactures: The Mott direct pressure sand-blast machine, hose type; the Mott sand-blast tumbling barrel, revolving table and cabinet, type G; the Mott type P.V.S. double sand-blast tumbling barrel, and Mott sand-blast accessories.

CENTRIFUGAL PUMPS.—Catalogue H-2, recently issued by the Lea-Courtenay Company, Newark, N. J., describes and illustrates the various types and sizes of Lea-Courtenay centrifugal pumps. The booklet, containing 64 pages, is divided into 12 chapters, dealing, respectively, with the care taken in the manufacture of this company's product and the characteristics of the pumps. The booklet is profusely illustrated.

NATIONAL PIPE.—Bulletin No. 20, recently issued by the National Tube Company, Pittsburgh, Pa., is an index to Bulletins Nos. 1 to 20 which have been issued by this company. The bulletin represents an index of considerable detail, the idea being to offer pipe information readily accessible to the reader. The last two pages of the bulletin give a detailed list of the bulletins to which reference is made.

BORO-CARBONE.—The Abrasive Material Company, Philadel-

phia, Pa., has recently issued a pamphlet describing the Boro-Carbone, which is a new type of abrasive recently placed on the market. This material is oxide of alumina, produced in crystalline formation in an electric furnace. The pamphlet contains a description of this abrasive, the various forms produced by the company being illustrated. Various other information of interest to handlers of grinding wheels is also included.

LOCOMOTIVES FOR PLANTATION SERVICE.—Record No. 80, recently issued by the Baldwin Locomotive Works, is devoted to the subject of locomotives for plantation service. In the booklet there are shown 29 different designs of locomotives suitable for this kind of work. These vary in type and capacity from light, four-coupled engines, suitable for switching service and short hauls, to large engines of the Consolidation type, which are qualified for road service. Information is given covering the hauling capacity of each locomotive illustrated, as well as the other principal general dimensions.

SAFETY CODE FOR ABRASIVE WHEELS.—The Abrasive Material Company, Philadelphia, Pa., has recently issued a pamphlet containing the safety code for the use and care of abrasive wheels and the parts of grinding machines related thereto, which has been approved by a number of the abrasive wheel manufacturers. The code is divided into five sections dealing with protection flanges, protection hoods, cups, cylinders and sectional ring wheels, general safety requirements and precautionary suggestions. There is also included in the pamphlet a table of the causes of grinding-wheel accidents, reprinted from Grinding Wheels.

RESULTS OF ELECTRIFICATION.—This is the title of Circular No. 1505, which has recently been issued by the Westinghouse Electric & Manufacturing Company, East Pittsburgh, Pa. This so-called circular is a book 9 in. by 11 in. in size, containing 72 well-illustrated pages. It aims to show the results obtained by electrification on some of the important steam railways of the world and to give information of interest and value to steam railroad operators on electrification work. Contained in the publication are well-illustrated descriptions of the Norfolk & Western, the Pennsylvania, the New Haven and other electrifications installed by the Westinghouse company. The Westinghouse Electric & Manufacturing Company has also recently issued the first number of "Westinghouse Electrification Data," which is to be a periodical to chronicle the latest advances in the field of heavy traction. The present number contains a discussion of electric locomotive characteristics, some interesting figures on the comparative maintenance costs of steam and electric locomotives, as well as data on the New York terminal electrification of the Pennsylvania.

CENTRIFUGAL AIR COMPRESSORS.—The De Laval Steam Turbine Company, Trenton, N. J., has recently issued a 64-page book dealing with centrifugal blowers and compressors for all pressures from 5 in. of water, as in mechanical draft service, up to 125 lb. per sq. in., as for compressed air distribution in mines, machine shops, shipyards, etc. The development of the high efficiency, high speed centrifugal blower or compressor has depended upon improvements in materials, construction, shop practice and design such as are employed in the building of high-grade steam turbines. In the present publication numerous charts are given showing curves for the isothermal, adiabatic and actual compression of air, also the theoretical power required to compress air and characteristic curves of single and multi-stage blowers and compressors. The influence of impeller design upon the form of the characteristic is discussed at some length. Particulars are given concerning the application of centrifugal blowers and compressors to forced draft, coal gas manufacture, coke oven plants and water-gas plants, sugar factories, cupola and blast furnace work, Bessemer converters, supplying compressed air in mines, shipyards, etc. The illustrations present numerous examples of blowers and compressors directly connected to steam turbines and to electric motors.

Railway Age Gazette

MECHANICAL EDITION

INCLUDING THE AMERICAN ENGINEER

PUBLISHED ON THE FIRST THURSDAY OF EVERY MONTH BY THE
SIMMONS-BOARDMAN PUBLISHING COMPANY
WOOLWORTH BUILDING, NEW YORK, N. Y.

CHICAGO: Transportation Bldg. CLEVELAND: Citizens' Bldg.
LONDON: Queen Anne's Chambers, Westminster.

EDWARD A. SIMMONS, *President* L. B. SHERMAN, *Vice-President*
HENRY LEE, *Secretary-Treasurer*

The address of the company is the address of the officers

ROY V. WRIGHT, *Editor*

R. E. THAYER, *Associate Editor* A. C. LOUDON, *Associate Editor*
C. B. PECK, *Associate Editor*

Subscriptions, including the eight daily editions of the *Railway Age Gazette* published in June in connection with the annual conventions of the *Master Car Builders' and American Railway Master Mechanics' Associations*, payable in advance and postage free:

United States, Canada and Mexico..... \$2.00 a year
Foreign Countries (excepting daily editions). 3.00 "
Single Copy 20 cents

Entered at the Post Office at New York, N. Y., as mail matter of the second class.

WE GUARANTEE that of this issue 7,500 copies were printed; that of these 7,500 copies 6,021 were mailed to regular paid subscribers, 97 were provided for counter and news companies' sales, 228 were mailed to advertisers, exchanges and correspondents, and 1,154 were provided for new subscriptions, samples, copies lost in the mail and office use; that the total copies printed this year to date were 60,300, an average of 6,030 copies a month.

The RAILWAY AGE GAZETTE, MECHANICAL EDITION, and all other Simmons-Boardman publications are members of the Audit Bureau of Circulations.

The Car Inspectors' Competition

More papers were received in the car inspectors' competition than in any competition that we have ever held, and the indications are that much valuable data is contained in them. They have been referred to the judges in the contest, and it is planned, if the decision is received in time, to publish the prize winner in the November issue. We take this opportunity of again thanking those who contributed and helped to make it a success.

The Railway Electrical Engineer

The Simmons-Boardman Publishing Company, publishers of the *Railway Age Gazette*; *Railway Age Gazette, Mechanical Edition*; and *The Signal Engineer*, has purchased the *Railway Electrical Engineer*, which has been published for several years in the interests of electrical men in steam railway service. The number of cases of partial electrification of steam roads in recent years, and the promise of more extensive development along this line in the near future, together with the growing use of electricity on railway equipment of all kinds and in the operation of shops, engine houses, offices and yards, make necessary the development of a strong journal in this field. The *Railway Electrical Engineer* will cover it in detail in the same way as the *Mechanical Edition* does the mechanical department. It will not conflict with the *Railway Age Gazette*, which will consider the electrical problems in their broader aspects and for the information of the higher officers. On the other hand, both the *Mechanical Edition* and the *Railway Age Gazette* will profit by having a strong electrical editorial staff co-operating with them.

Steel Freight Car Competition

Steel freight cars have now been in service in large quantities on a number of roads for a sufficiently long time to develop their weak points and enable car department officers to place their fingers on those parts or features which need further attention. What are the weak points of steel freight cars, and how should they be strengthened? We invite discussion from both the practical car man and the designer. Too often these two classes do not work closely enough together; sometimes the car designer neglects to follow the cars after they are put in service. Then, too, the practical

CONTENTS

EDITORIAL:

The Car Inspectors' Competition.....	495
The Railway Electrical Engineer.....	495
Steel Freight Car Competition.....	495
Education of Locomotive Firemen.....	496
Boiler Inspectors' Competition.....	496
Eliminate Old Equipment from Interchange Service.....	496
The Apprentice Letter Competition.....	496
A Car Department Association.....	497

COMMUNICATIONS:

The Draft Gear Problem.....	498
Strengthening of Underframes.....	498

GENERAL:

Traveling Engineers' Convention.....	499
New York Central Smoke-Washing Plant.....	511
Prepared Paints for Metal Surfaces.....	513
Exhaust Injectors.....	514

CAR DEPARTMENT:

Design of Steel Passenger Equipment.....	515
The Car Department and the Expediting of Preferred Freight.....	516
Northern Pacific Passenger Cars.....	517
Chief Interchange Car Inspectors' and Car Foremen's Association Convention.....	522
Steel Car Design from a Protection Standpoint.....	525
Piece Work for the Paint Shop.....	526

SHOP PRACTICE:

Repairing Driving Boxes.....	527
A Possible Substitute for Acetylene in Welding and Cutting.....	529
Repairing 9/16-In. Air Pump Cylinder Heads.....	530
Y-Fitting for Washing Out Boilers.....	530
How Can You Help the Apprentice?.....	531
"Big Bill" Agnew and "Blue Monday".....	533
Railway Repair Shop Organization.....	536
Closing Valve Motion Links with the Oxy-Acetylene Torch.....	538
Master Painters' Annual Meeting.....	539
Rotary Four-Way Valve.....	542
Flue Cutter.....	542

NEW DEVICES:

Boring and Turning Mill.....	543
Belt Shifter.....	543
High-Speed Hack Saw Machine.....	544
Collapsible Tap.....	544
Flat Plate Air Compressor Valves.....	545
Adjustable Car Step.....	546
Automatic Adjustable Driving Box Wedge.....	546
Riveting Machine.....	547
Safety Wrecker Yoke.....	547

NEWS DEPARTMENT:

Notes.....	548
Meetings and Conventions.....	549
Personals.....	549
Supply Trade Notes.....	551
Catalogs.....	552

man who takes care of them, and repairs them, does not always understand how to bring his superiors to a full realization of the importance of the defects which he discovers. With this in mind, we invite car men, as well as designers and others, to participate in a competition on the subject of "Lessons to be Learned from Experience with Steel Freight Cars." For the best contribution on this subject received at our offices in the Woolworth building, New York, on or before December 1, 1915, we will give a prize of \$35. Other contributions which we may select for publication will be paid for at our regular rates. The judges will base their decision on the practical value of the suggestions which are made.

Education of Locomotive Firemen

"For whatsoever a man soweth, that shall he also reap"—a quotation from the Bible, familiar to all, and never more true than in the case of educating the locomotive firemen and supervising their work. It has been shown in many cases how by proper education and supervision the coal bill has been materially reduced with a very large return on the money spent for the education and supervision. This year the Traveling Engineers' Association received a very complete and instructive report on this subject. It was clearly shown that in addition to the direct results obtained from the reduction in the consumption of fuel a better understanding would be obtained between the firemen and their superiors if the instruction were given in the proper spirit. Realizing that the company was spending money for their education and that it was thoroughly interested in making them a success in their chosen profession, there will naturally be created a relationship between the firemen and the officers they serve that is certain to be of great indirect advantage to all the roads on which such practices are followed.

It is the most natural thing for the average man to want to learn and improve his condition, and he who assists in this respect is that man's friend. Two results are thus obtained—a decrease in fuel consumption and a friendly employee, one who has faith in his officers and whose aim is to further their best interests. Locomotives consume over \$250,000,000 worth of fuel each year. One-half of one per cent of this amount would pay for a supervisor at \$1,800 a year for approximately every 100 engines in service on the roads of this country, who, in order to earn his salary, must save one scoop of coal out of every 200 shoveled by the firemen and hostlers under his jurisdiction. This is an absurdly simple thing to do, as the results have shown on those roads that have even the poorest systems of education and supervision. All above the one shovel-full per 200 is clear profit for the railroads, and it will be found that the investment will prove most profitable.

Boiler Inspection Competition

The first announcement of the boiler inspection competition was made in our September issue, page 439. With the inauguration of the federal locomotive boiler inspection requirements a few years ago the railroads found it necessary to give much more attention to boiler inspection than they had in the past, and to develop a force of capable inspectors of their own. These men, to perform their work efficiently and effectively, must be provided with certain facilities and must use the best methods and practices. They are widely scattered, however, and have not had opportunities of getting together and comparing notes. True, they have had the benefit of advice from the federal inspectors, each one of whom covers a considerable amount of territory, but even these men were new on the job. Some of the more progressive inspectors have developed facilities and methods of performing their work which are far beyond the average; some excel in one respect, others in another. The purpose, then, of this competition is to encourage those who have developed and are fa-

miliar with those practices and methods to send in descriptions of them in order that we may act as a sort of clearing house for such data. You may say that you are located at a small or unimportant point, and are not capable of discussing the matter in the way that your friend at a larger terminal with better facilities may be able to do. Remember that there are many others situated as you are, and that it is just as important to place on record the best way of doing things at the smaller and comparatively unimportant places as it is at the larger ones. Possibly more so, for these smaller terminals far outnumber the larger ones. The object of the competition is to develop facts and practical suggestions which will help improve the effectiveness of the locomotive boiler inspector. A prize of \$35 will be given for the best article on this subject which is received at our offices in the Woolworth building, New York, on or before November 1. The judges will base their decision on the practical value of the article rather than on its composition or grammatical arrangement.

Eliminate Old Equipment from Interchange Service

There has been so much trouble caused by the bad order freight cars in Chicago switching district in the past that a committee was appointed by the General Superintendents' Association of Chicago to investigate this problem. This committee has made its report to that association, and the report was also presented as a paper before the Western Railway Club, an abstract of which appears elsewhere in this issue, for the purpose of obtaining as much discussion on the subject as possible. The investigation of the committee was very thorough, and a number of very valuable suggestions were made. But the committee, being made up of transportation officers, was not thoroughly conversant with the difficulties experienced by the mechanical department in the handling of bad order cars the country over, and its criticism of the M. C. B. rules savored a little of the idealist.

There is no question that the bad order cars are an unmitigated nuisance, especially when it is considered that in Chicago alone 29,779 loads were transferred last year on account of defective equipment, and most of those cars, it is believed, were loaded while in that condition. That, of course, is inexcusable, and demonstrates the lack of proper inspection. There is another point which also should be considered, and that is the unrestricted interchange of old and what might be termed unfit equipment. Leaving the M. C. B. rules as they are, which, though far from perfect, undoubtedly take care of the freight equipment the country over as well as possible under the present conditions, a tighter line may be drawn on the equipment to be allowed off the home rails. It is to be expected that the wooden cars will not stand the present day service in the long trains and hump yards when mixed in with a lot of stiff steel underframe cars. These cars transmitting more and absorbing less of the shocks, batter the wooden weaklings into "bad orders" much quicker than if all the equipment were of wood.

This is a period of transition, and as the quantity of the reinforced equipment increases, so should more of the weaker wooden equipment be kept at home. The M. C. B. Association has already agreed not to permit the interchange of equipment of capacity under 60,000 lb. after October 1, 1916, and until that time every road should, of its own accord, limit the use of that equipment in so far as possible.

The Apprentice Letter Competition

Eighteen letters were received in the contest on "How Can I Help the Apprentice Boys?" which was announced in our August issue, page 439. Three of the letters were disqualified as far as awarding the prize was concerned because of their length, the announcement distinctly stating that they should not contain more than 650 words. Several

of the writers apparently overlooked the "I" in the question and described ideal apprentice systems, or apprentice systems now in use, rather than telling how they as individuals could be helpful to the apprentice. This too disqualified some of the letters. All, however, were good, and while they may not have met the particular requirements of the competition, possess sufficient merit to warrant our making use of them in whole or in part.

The judges found great difficulty in arriving at a decision, but finally awarded the prize of \$10 to John Smith, of the Baltimore & Ohio, at Lorain, Ohio. Mr. Smith approaches the question from the standpoint of the boiler shop and pleads for sympathy and practical co-operation with the apprentice. His letter, together with three others which were selected at random, appears elsewhere in this issue. The others or extracts from them will appear in both the November and December issues.

The letters as a whole possess a peculiar value because of the widely varying viewpoints and experiences of the different writers. For instance, the positions held by the contributors vary from mechanic to assistant superintendent of motive power, and from apprentice instructor to assistant professor of machine design. Except for two apprentice instructors and two foremen all of the 18 writers have different titles. The machine shop, erecting shop, boiler shop, paint shop, air brake department and engine house are all represented. In addition there are a traveling inspector, two shop draftsmen, a special apprentice and a shop superintendent.

One thing stands out quite clearly and that is the appreciation of modern apprenticeship methods. Ten years ago this journal started to advocate such methods strenuously and has kept at it more or less steadily ever since. Apprenticeship methods on progressive roads have been revolutionized in that time, although much still remains to be done, and far too few roads have awakened to their responsibilities in the matter. The competition was not designed so much to develop this, however, as to suggest ways in which the individual officers, foremen or mechanics could lend their aid in helping the apprentice to make the best of his time and opportunities. "What can I do?" was the question. It is answered in many different ways, and we hope that our readers will be inspired to take a greater personal interest in the boys and young men with whom they come in contact in the shop and in the office.

A Car Department Association

At the recent convention of the Chief Interchange Car Inspectors' and Car Foremen's Association, President Hanson announced that plans were under consideration for widening the range of the work of the association. Under the plan now followed its efforts are practically all devoted to securing uniformity in the interpretation of the Master Car Builders' rules of interchange. The convention is held before the annual revisions go into effect on October 1, the time being quite largely used in the discussion of these rules, thus providing for uniformity in interpretation of the revisions when they become effective. Through the executive committee, which meets during the winter for that purpose, suggested revisions of the rules are considered and recommendations for needed changes are made to the arbitration committee of the Master Car Builders' Association.

The importance of the results which have come from the work of this association cannot be overestimated. It has undoubtedly been the means of eliminating much friction in the administration of the rules of interchange, and has succeeded in securing revisions in the rules to correct many evils and improve their operation. This work, however, is all of much more vital interest to the car inspector than to the car foreman. The object of the association as outlined in the constitution, in

addition to the consideration of the rules of interchange, is to make such recommendations as are considered advantageous in the construction and maintenance of cars. This interests the foreman in so far as the relation of car construction to maintenance is concerned, but since matters of car design are largely in the hands of others than the car foreman, and are now being exhaustively considered by the Master Car Builders' Association, this feature does not seem to offer a profitable field for the future activity of the Chief Interchange Car Inspectors' and Car Foremen's Association. There are, however, many matters of prime interest to car department officers and foremen which this association could profitably consider. In the locomotive department there are several foremen's associations, each of which finds much to consider, and each of which has been of great benefit to the service in its particular field. The car shop and the repair track have their own peculiar problems, which are undoubtedly being solved in many different ways at different points. Where much of the work which should have the attention of skilled mechanics must be gotten out with unskilled labor, the problem of securing and training men is one which might well be considered by an association of car foremen and inspectors. How to remedy the present rather lax methods of dealing with defective car doors and leaky roofs might be profitably considered. And there are numerous problems of car shop and repair track organization and arrangement awaiting solution. In taking up these matters, the Chief Interchange Car Inspectors' and Car Foremen's Association will be greatly strengthening itself by increasing its capacity to be of service to one of the most important, and often the most neglected, departments of a railroad. The association is to be congratulated on the beginning which is being made in the announcement that prizes are to be offered for the three best papers secured on the subject of apprenticeship in the car department, for presentation before the next convention.

This need not be done at the expense of proper consideration of the rules of interchange. Now that a uniform understanding of these rules has generally been effected, much of the need for general discussion is eliminated. The determination and presentation of the points in the rules most needing consideration might be left in the hands of a committee, with a saving of much time to the association. Time might thus be made available for an open discussion of proposed revisions, which would be of considerable benefit in bringing about a better mutual understanding with a resulting reduction in the number of proposed revisions of a local nature.

NEW BOOKS

Oxy-Acetylene Welding and Cutting. By Calvin F. Swingle, M.E. 190 pages, 4½ in. by 6½ in. Illustrated. Bound in leather or cloth. Published by Frederick J. Drake & Co., Chicago. Price, \$1.50 in leather; \$1.00 in cloth.

This book is intended as a practical treatise on the subject of welding and cutting with the oxy-acetylene flame, and only so much of the theory pertaining to the subject has been included as will enable the practical man to acquire a thorough working understanding of the subject. After an introductory chapter dealing briefly with the adaptability of various methods of welding, several chapters are devoted to welding flames and the properties and methods of handling the gases most commonly used. This portion of the book is confined largely to the oxy-acetylene flame, which has the widest practical application, and touches only briefly on other gases which have been used with oxygen to a less extent in welding and cutting operations. The equipment used in welding and cutting is next discussed, after which the operation of the plant and the practices followed in welding and cutting are taken up. A final brief chapter is devoted to the subject of carbon removal with the oxygen torch. The book contains a large number of illustrations and tables.

COMMUNICATIONS

THE DRAFT GEAR PROBLEM

CLIFTON FORGE, Va.

TO THE EDITOR:

Draft gear was discussed extensively through the medium of your valuable paper last year and much information was obtained as to the relative value of both the spring and friction gears. The thought occurred to me that it would be well to take up the question of how best to apply and maintain whatever sort of draft gear equipment we are required to deal with.

There is no question but that a great many draft gear failures are due to rough handling of cars both in classification yards and on the road, over which the mechanical department has no control. At the same time many of these failures could be avoided

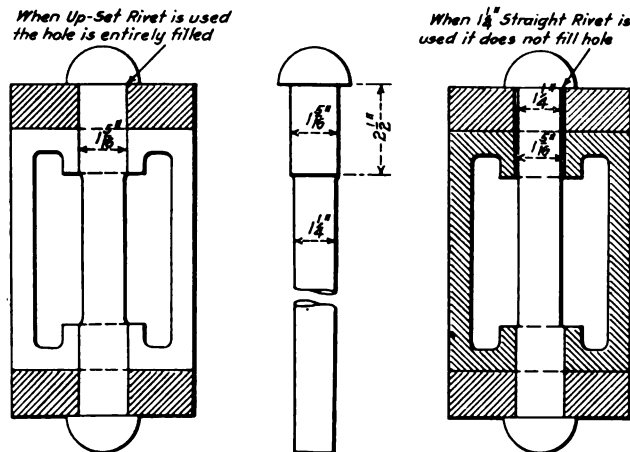

Illustrating the Advantage of Using the Upset Rivet for Fastening the Yoke to the Coupler

by the proper application and maintenance of the draft gear. The bulk of the failures are due to the coupler yoke and coupler parting at a point where they intersect, due to the poor method used in riveting the yoke to the coupler. The principal deficiencies that we find are as follows:

Rivets do not fill the hole in the coupler shank and yoke, which contributes very much to the rivets shearing. In many cases bolts are used that are entirely too small for the purpose, and the nuts work loose, due to the continuous vibration of the coupler. This permits the yoke to spread until the lug on the yoke is of no holding value and the rivets or bolts shear, causing a draft gear failure. It is general practice to use rivets 1 1/4 in. in diameter for riveting the yoke to the coupler. The rivet hole in the coupler and yoke is usually 15/16 in. in diameter, or 1/16 in. larger than the rivet. This allows the yoke to vibrate on the coupler and will, in my opinion, cause trouble sooner or later.

To eliminate this trouble we have adopted the practice of increasing the diameter of the coupler rivet under the head 1/16 in., as will be noted on the drawing. This is done in order to fill the rivet hole. The other end of the rivet is heated to a white heat, after which it is driven into position and riveted over with a pneumatic riveter, which forms a good head and upsets the rivet in the hole, filling it. This practice is no doubt saving the company many dollars, as up to the present we have not been able to find a single failure where it was used.

The friction and the spring draft gears both have their merits and demerits; however, I do not think that at this time the railroads of the country are in condition financially to make any great additions and betterments to their equipment, hence it should be the disposition of all who are in any way responsible for the maintenance of the equipment, to lend every effort to the application and upkeep of this important device. If this is done I am sure that there will be a decrease in draft gear failures, which are expensive to the railroads and retard traffic to a great extent.

E. A. MURRAY

Master Mechanic, Chesapeake & Ohio

STRENGTHENING OF UNDERFRAMES

CHICAGO, Ill.

TO THE EDITOR:

I have considered carefully your editorial on "Underframes Should Be Strengthened" in the July issue. You state that there seems to be but one remedy, the application of either a full steel underframe or steel center sills.

There is no doubt that the underframe is the foundation of any car, and it must be made sufficiently strong to withstand the severe shocks under the present conditions of service. This has been badly neglected on many railroads. However, from personal experience, I believe that the older cars, with wooden sills, can be strengthened enough to endure these shocks by the application of a steel arm, bolted to the center sill and extending a certain distance back of the body bolster—the steel arm having the draft gear pocket cast integral with it.

An L-shaped steel arm properly designed, going under and up the side of the center sill, lapping the body bolster and extending about 30 in. beyond, far enough at any rate to reinforce the sill at its weakest point, is of stronger construction than 60 per cent of the steel underframing under many cars now in service. It will stand greater shocks before the center sill will break.

The fact seems to be that on account of the difference in elasticity between wood and steel, the long slender steel center sill has to take all of the strain, and buckles under heavy impact, whereas the shorter steel arm delivers these stresses to the body bolster and spreads them over the entire wooden sill structure, which seems to have more resisting power than the steel center sill by itself. The weakness of the old wooden draft arms was the inadequate means of attaching the draft rigging to them and the difficulty of securing a proper attachment to the center sills and bolster. The steel arm, with the draft pocket cast integral and embracing the body bolster, seems to overcome these difficulties.

There are a great many 60,000 lb. capacity box cars and 80,000 lb. capacity wooden coal cars still in service, and it is necessary for the railroads to continue to run and maintain these cars. The application of a steel underframe, plated top and bottom, will cost approximately from \$115 to \$135, depending on the method of construction. The above mentioned steel arm, well designed, can be applied for approximately \$70 to \$85. This arm will strengthen such cars to meet the present traffic conditions and will save the railroad the difference in cost. The steel underframe means approximately \$40 to \$50 more expense per car and promises less endurance.

A steel arm can be applied without removing a cracked or split sill. It eliminates the heavy maintenance expenses of draft gears and also the delays to cars from draft sill repairs.

At the recent M. C. B. Convention the Committee on Car Construction ruled that the owner of a car equipped with steel arms would be allowed an additional amount of \$65 if such a car were destroyed on another line. This would seem to indicate that some of the members of the committee felt that a car so equipped was strengthened sufficiently to meet the present requirements and necessities of traffic.

I do not mean to imply that full steel underframes should not be used on the new cars which are being constructed. I merely do not believe that it is necessary to go to the heavy expense they entail in the case of 60,000 lb. box and 80,000 lb. coal cars. That is the idea I wish to present for your consideration. J. T.

WATERPROOFING BLUEPRINTS.—Blueprint drawings made on paper can be readily waterproofed by placing them between pieces of muslin that have been saturated with paraffin and passing a hot smoothing iron over them, thus causing enough paraffin to be absorbed by the drawings to render them impervious to water. The paraffined cloths can be prepared by soaking pieces of muslin about 12 in. square in molten paraffin obtained by melting down paraffin candles. When thoroughly saturated the cloths should be hung in a warm place to drain and dry and when thus prepared can be used a number of times.—*Power.*

TRAVELING ENGINEERS' CONVENTION

Reports on Locomotive Appliances, Tonnage Rating, Education of Firemen and Smoke Prevention

The twenty-third annual convention of the Traveling Engineers' Association was held in Chicago, September 7-10, J. C. Petty, of the Nashville, Chattanooga & St. Louis, presiding. The opening prayer was made by Bishop Fallows, after which the president made a brief address of welcome. He also directed special attention to the economies that may be obtained by the co-operation of the traveling engineers with the other departments of a railway.

As is customary at the meetings of this association several special addresses were included in the program, in addition to the committee reports and technical papers. These included addresses by C. H. Markham, president, Illinois Central; F. W. Brazier, superintendent rolling stock, New York Central Lines east of Buffalo; Frank McManamy, chief inspector of locomotive boilers, Interstate Commerce Commission, and Warren S. Stone, grand chief, Brotherhood of Locomotive Engineers.

Mr. Markham took occasion to pay tribute to the courage, skill and intelligence of the engineer. He also spoke of the unfair attacks on railroads and the fact that there was entirely too much regulation. He urged unity of all railroad forces in the great movement toward securing a better understanding of railroad problems and better treatment of the railroads. He emphasized also the necessity of seeing that the internal relations of the railroads should be amicable, stating that a great strike would be followed by government ownership.

Mr. Brazier sketched briefly the development of locomotives and cars in recent years. He mentioned several prominent railway men that had started their railway careers on the locomotive, calling attention to the opportunities of the traveling engineer for advancement.

Mr. McManamy spoke of the necessity of obtaining good intelligent men as firemen, and called attention to the necessity of keeping locomotives in safe and serviceable condition. Since the boiler inspection law has been in effect accidents causing injury have been reduced by 51 per cent; the number killed from these accidents has been reduced 86 per cent, and the injured 54 per cent. This also must indicate a reduction in engine failures. He spoke of the locomotive inspection rules as being designed to protect the enginemen from injury due to defective equipment.

Warren S. Stone, grand chief, Brotherhood of Locomotive Engineers, made a brief address during the session Friday morning. He spoke of the traveling engineer as the intermediary between the engineer and the railway officers. Some roads are getting far better results from their enginemen than others, having obtained their implicit confidence by dealing with the men fairly and honestly. He called upon the traveling engineers to "play the game square" and to be sure and place the blame for an accident where it properly belongs, whether it be on the man, machine, roadbed, or wherever it may be.

MODERN APPLIANCES ON LARGE LOCOMOTIVES

Superheaters.—Two important changes in locomotive superheater practice that have been introduced since the last report of the committee on superheaters are a modified header design and a continuous pipe or torpedo unit. The construction of the header is such as to prevent the occurrence of stresses due to unequal expansion and contraction, by casting the saturated steam passage-ways free at one end. The continuous pipe unit is made by forging the return bends on the ends of the unit pipes. This unit reduces the restriction to the flow of gases.

The application of the superheater to the small locomotive raised the capacity limit 25 per cent to 30 per cent, and by the

adoption of the superheater, larger engines, greater train lengths and faster schedules have been made possible.

The superheater under actual operating conditions saves 20 per cent of the total fuel burned and from 30 per cent to 35 per cent of the water used over the saturated locomotives developing the same horsepower. The superheater locomotive may be worked at longer cut-offs and at higher speeds, making possible longer trains and faster schedules than is possible with identical saturated locomotives, under the same conditions. The comparative curves shown in Fig. 1 give the average draw-bar horsepower developed at corresponding speeds of two Class H-21 locomotives on the Erie Railroad—engine 1625 used saturated steam and engine 1654 superheated. These curves show one of the advantages of superheating a locomotive, whose ability to haul full tonnage train over a railroad on a faster schedule is limited by the capacity of the engine boiler.

Tests made on the Central of Georgia with a superheater and a saturated steam locomotive in passenger service under practically the same conditions showed that for the superheater locomotive the cost of fuel per hundred miles run was \$5.01, as against \$5.89 for the saturated steam engine. On a basis of the fuel used per 1,000-ton miles the performance of the saturated steam locomotive was only 80.28 per cent as good as the superheater locomotive. The Grand Trunk has applied superheaters to a good many saturated steam locomotives and the benefit derived as shown by tests has been so much in favor of the superheater locomotive that the management has decided to superheat all road engines as they pass through the general shops. The following is a comparative result of tests with two simple Consolidation locomotives, one (623) having been converted to a superheater:

	Engine 825, simple con- sol. satu- rated steam	Engine 623, simple con- sol. super- heat steam	Increase or decrease of superheated as compared with satu- rated loco- motive (per cent)
Average number of cars in train....	51.88	38.	26.07 D.
Total gross weight of train in tons	2,065.18	2,153.07	4.02 I.
Average weight per loaded car....	39.62	57.79	45.08 I.
Total train miles.....	125.19	125.	.15 D.
Total car miles.....	6,497.	4,759.	26.07 D.
Total ton miles.....	258,964.	269,559.	4.09 I.
Coal consumed in pounds.....	21,307.	13,400.	31.01 D.
Coal consumed in lbs. per train mile	170.12	106.75	37.02 D.
Coal consumed in lbs. per car mile..	3.27	2.95	9.08 D.
Coal consumed in lbs. per ton mile..	.084	.050	30.04 D.
Total water evaporated in lbs.....	137,614.	98,213.	28.06 D.
Water evaporated per lb. of coal..	6.51	7.36	13.00 I.
Average boiler pressure.....	200.04	173.65	10.03 D.
Average speed in mile per hour....	22.31	26.00	16.05 I.
Miles run with one ton of coal....	11.82	18.76	58.07 I.
Actual running time.....	5 hr. 30 min.	4 hr. 49 min.	12.04 D.

The application of the superheater to the locomotive boiler, frequently inadequate as to heating surface, necessitates a reduction of about 15 per cent or 20 per cent in the tube heating surface. Notwithstanding this fact the use of superheaters has resulted in greater locomotive capacity. As an illustration of this fact, Fig. 2 is presented. It shows cylinder tractive effort in per cent plotted against piston speed. The lowest curve, No. 1, very fairly represents the speed factor for an average saturated steam locomotive. Curve No. 2 similarly represents the average modern superheated steam locomotive, using between 200 and 250 deg. of superheat. The greater tractive effort available is due to the fact that a longer cut-off is possible with the superheater engine than with saturated steam at the same speeds.

If the superheater designer were permitted to use a size of tube

different from the two present standards, it is possible to obtain in a superheater boiler an evaporating surface practically as great as in the saturated steam boiler. With a boiler and superheater thus arranged, a greater capacity may reasonably be expected, and a curve approximately that shown as No. 3 may be confidently looked forward to in the near future. This curve is representative of locomotives using 350 to 400 deg. of superheat.

There have been several pyrometers put in service on superheater locomotives during the past year, and as the engineers become more familiar with the purpose and operation of the

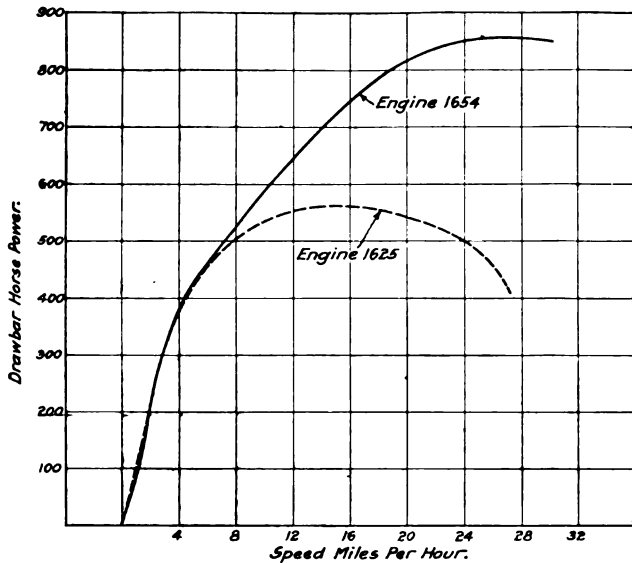

(Engine 1654, superheated steam; Engine 1625, saturated steam)
 Fig. 1—Average Drawbar Horsepower Developed by Superheated and Saturated Steam Locomotives at Different Speeds

pyrometer, they realize more and more its importance. Those of the electrical type have been in service and operating continuously for a sufficient length of time to establish the fact that they may be depended upon in locomotive service. When the pyrometer fails to read 600 and 650 deg. when the engine is working steam it is an indication to the engineer that he is not handling the locomotive so that the maximum saving which the superheater makes available is being obtained.

Grates.—Judging from the number of replies received there are a large number of different designs of grates, varying in air space from 25 per cent to 50 per cent of total grate area. The committee is not in a position at the present time to recommend any particular design, but special attention should be given to the amount of air opening in the grates, using as large a per cent of the area as possible (40 per cent being a fair average).

Mechanical grate shakers are a decided advantage on heavy power and engines with large grate areas. They are of great assistance to the fireman in keeping the fire clean and in getting sufficient air through the grates, thus insuring thorough burning of the coal and gases. This device probably effects the greatest saving at the ash-pit when fires are being cleaned or dumped, as locomotives which were consuming 35 to 40 minutes from ash-pit to roundhouse are now consuming 10 to 20 minutes, and it only takes two men to handle the engine on the ash-pit, where it formerly took four—a reduction of 50 per cent in labor.

Drifting Valves.—The committee believes that some means should be provided to admit a sufficient amount of steam to cylinders and valve chambers, not only on superheat locomotives, but on any locomotive having cylinders of a large diameter. This will not only prevent carbonization, but will cause the engine to drift much more smoothly. The rods will require less keying up and the maintenance of wedges and journal bearings will be easier and piston heads and cylinders will not wear as fast.

Brick Arches.—Several years ago the brick arch was looked upon and spoken of only as a fuel-saving device, but the constantly increasing demand for greater capacity has resulted in

changing its recognized function from a fuel saver to a capacity increaser. The arch increases the boiler capacity directly by aiding combustion and by reducing the heat losses. Naturally this results in increasing boiler efficiency. The arch tubes which support the brick add valuable heating surface and increase the circulation of water through the boiler. The brick arch separates the fuel bed from the tubes and forms a sort of combustion chamber in what would otherwise be a straight firebox. As shown in Fig. 3, the efficiency of the arch increases as the rate of combustion or the amount of coal burned per square foot of grate area per hour increases. When burning 30 lb. of coal per hour per square foot grate area, we may expect an efficiency of 3 per cent; when burning 100 lb. per hour per square foot of grate area, we may expect an efficiency of 10 per cent., etc.

Tests indicate that at a rate of combustion of 100 lb. of coal per square foot of grate area per hour, the arch will effect a reduction of 42 per cent in spark losses. This would mean an increase in boiler efficiency of 7 per cent, due to this one item. Reports from many roads indicate a smoke reduction of 50 per cent can be obtained by the use of the arch, and on most roads the brick arch, together with proper firing instructions, have proved sufficient to overcome objectionable smoke and to keep within the law.

Flange Oilers.—Ever since locomotives have been in use, the wear on the wheel flanges has been one of the, if not the, greatest sources of annoyance and expense in maintaining these powerful machines in service. The modern locomotive and high speed demanded has increased instead of decreased it. A very conservative estimate of the loss to one engine for one turning of tires on account of flange wear is \$219. The following is an estimate of the mileage a locomotive will make between turning of tires for flange wear, with and without a flange oiler:

FREIGHT		PASSENGER	
Miles without oiler	Miles with oiler	Miles without oiler	Miles with oiler
9,000 to 12,000	25,000 to 42,000	15,000 to 25,000	60,000 to 84,000

The rapid wear of the rails can be eliminated to a certain extent by the use of a flange oiler which positively delivers a jet of asphaltum oil against the flanges of the locomotive driving wheels. On one division of the Erie the rail saving on curves

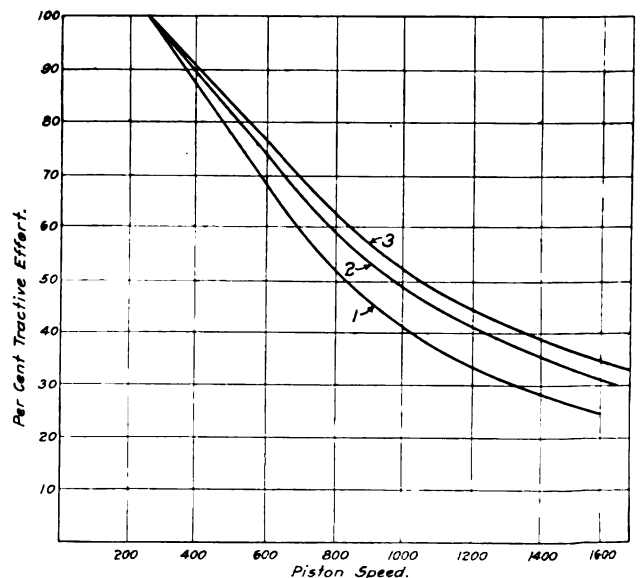

Fig. 2—Curves Showing Possibilities of Increased Capacity from Superheating

is 66 per cent. On the Delaware, Lackawanna & Western the saving on the rails on curves has warranted the equipping of locomotives with the flange oiler. While saving the rails on curves, the saving on the locomotive driving wheel tires on this road has been over 50 per cent. Positive proof is given by a number of roads that the flange oiler does prevent derailments.

It has been the impression that any crude oil would do to use

with any system of flange oiling. Service tests have proven that results cannot be obtained unless the oil contains from 40 per cent to 60 per cent of asphaltum in solution and is low in grease and paraffine. All oils that are low in asphaltum and high in grease and paraffine will run down on the tread of the driving wheel, causing slipping.

Mechanical Stokers.—In answer to questions submitted to the membership, the following replies were received: The stoker engines burn more coal, but as the grade of coal stoker fired is usually inferior to the coal used for hand firing, this feature should not be criticised too severely. With the same quality of coal there is very little difference. The hopper sometimes becomes clogged, causing stoker engine to stop in wet and freezing weather, but this depends largely on the watchfulness of the fireman. When the stoker fails, it usually causes an engine failure, due to the light fire carried and the grade of coal used,

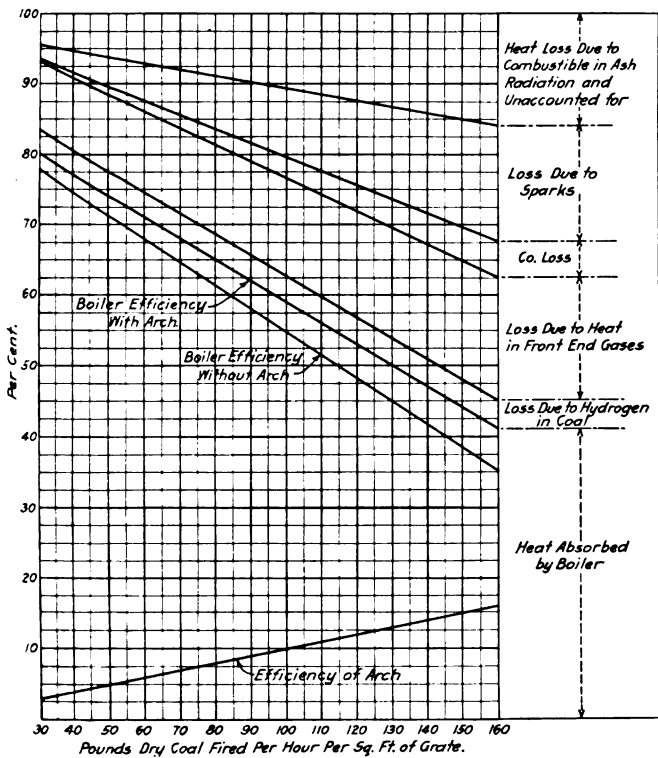

Fig. 3—Chart Showing Effect of Rate of Combustion on Efficiency of Boiler and Arch and on Heat Losses

making it impossible for a man to pick up the shovel and get the fire in condition without an engine failure, except in cases where the stoker is being worked very light.

In summing up, the advantages of the mechanical stoker are many. It is applied to heavy freight locomotives primarily to work the locomotive to its full capacity, regardless of the conditions under which it is operated, which, of course, means increased tonnage or increased average speed of freight trains under conditions where the tonnage is fixed—in other words, to increase the ton miles per hour over a division. Locomotives equipped with mechanical stokers carry a much lighter fire, which, of course, gives better combustion. A more uniform fire-box temperature is obtained, and correspondingly less flue and fire-box trouble. With the scatter system of firing a locomotive the smoke density will remain more uniform with the stoker-fired locomotive. The application of mechanical stokers to locomotives has made it possible for any fireman to handle any locomotive, regardless of the manner in which it is worked. By the use of the mechanical stoker the fireman is able to follow his engine more regularly, makes correspondingly more money, and, as a result, is better satisfied, a condition which makes it less difficult to keep a locomotive in service, especially on a division where the conditions of firing are particularly severe and the

overtime runs high, due to the relief of firemen in the hot summer months.

On a number of roads a cheap grade of fuel is purchased especially for stoker-fired locomotives, and on other lines where conditions are such that small run-of-mine coal is supplied, an economy is effected in that the run-of-mine coal is screened and the poor coal is set aside for stoker-fired locomotives, leaving a much better grade of fuel for the hand-fired locomotives.

The following is a list of number of stokers in active operation, of different types:

Street	593	Ge	1
Crawford	301	Ayres	1
Standard	28	Kincaid	1
Hanna	18		

Power Reverse Gear.—Judging from the replies received, the power reverse gear is the ideal gear and is a decided advantage in freight and switching service and will soon pay for installation, due to time saved in making up trains and switching. In some cases the power reverse gear has not given the results expected of it in fast passenger service, principally owing to the neglect of certain small but important items of maintenance. The use of the screw reverse gear is advocated by many roads for fast passenger service owing to the possibility of very fine adjustment, but its principal drawback is its slowness in reversing, making it difficult to take slack.

Coal Passer.—It has been the experience of the chairman of the committee on the railroad with which he is connected, that locomotive tenders equipped with coal passers are a valuable asset to modern power. This device places the coal within easy reach of the fireman and eliminates the furnishing of men at different points to shovel the coal ahead. It also allows the doubling of divisions without taking coal, thereby reducing the amount of coal which has to be handled to the farthest terminal. The cost of maintenance of the coal passer is very low.

Automatic Fire Door.—The butterfly type of the automatic fire door is generally preferred to either the horizontal or vertical types. It is the smoothest working door, gives the least trouble on the road, and requires less repairs at terminals. By the use of this type of door, single-shovel firing is accomplished, which prevents a large amount of cold air from entering the fire-box and materially reduces the amount of fuel required to keep up steam pressure.

The report is signed by J. E. Ingling (Erie), chairman; P. J. Miller (N. Y. C. West.); H. F. Henson (N. & W.); W. A. Buckbee (Loco. Sup. Co.), and A. G. Kinyon (S. A. L.).

DISCUSSION

Representatives from the Erie strongly recommended the use of pyrometers on superheater locomotives, calling attention to the fact that a loss of 20 deg. of superheat will affect the evaporation of water one pound per indicated horsepower. The pyrometer also serves to give the fireman a much closer check on the condition of the fire and shows the engineer whether or not he is getting the most out of the engine.

The graphite lubricator has been found by several roads to materially increase the life of the cylinder packing rings. Tests on the Delaware, Lackawanna & Western demonstrated that by its use the valve leakage was reduced 51 per cent, and that there was a saving in fuel. In one test the fuel per 1,000-ton miles was decreased from 104.2 to 88.7 lb.

The question of using superheater or perfection valve oil on superheater locomotives received considerable attention. In almost every case the superheater oil was believed to be unsatisfactory in the air compressors, some roads providing separate lubricators with perfection oil to serve these attachments, while other roads use perfection oil for both the compressors and the cylinders. A. G. Kinyon contended that if it were possible to eliminate the air from the cylinders while the engine is drifting better results can be obtained with perfection oil than with the superheater oil, inasmuch as in the manufacture of superheater oil with its higher flash point its lubricating qualities are af-

fect. In either case, however, too much oil should not be used, as it will increase the carbonization in the cylinders. Some roads, in an endeavor to prevent air getting into the cylinders, have eliminated relief valves and substituted drifting valves with material success. Difficulty with respect to the Ragonnet reversing gear creeping on has in some cases been eliminated by lubricating the cylinder with a mixture of soft grease and graphite.

SCIENTIFIC TRAIN LOADING, TONNAGE RATING

O. S. Beyer, Jr. (Chicago, Rock Island & Pacific), presented a paper on scientific train loading, of which the following is an abstract:

Scientific train loading or tonnage rating takes into consideration, as far as may possibly be determined, every element affecting the economical movement of freight trains. These elements may be summarized as follows: Drawbar pull of locomotive; resistance of freight cars of all weights; grades; curves; condition of track; temperature, weather and wind; opposing traffic; length of division, and speed.

The object of a scientific tonnage rating system primarily is to give an engine the same amount of work to do regardless of whether a train is made up of heavy cars or light cars, or a mixture of them. Its further object is to load engines at all times in accordance with conditions of weather, temperature, wind, track, etc., so that freight will always be handled for the least expense possible per ton-mile.

The most scientific and simple system yet devised is the adjusted tonnage rating system. This system, when carried out to its logical conclusion, as its name implies, endeavors to adjust the loads of freight trains as exactly as possible to suit the conditions existing. In order to understand how the adjusted tonnage rating system accomplishes this object, its development for a division and application will be described.

The first element to be considered is the drawbar capacity of the locomotive used in hauling freight trains over the division, in conjunction, of course, with the grades and curves of the division and the desired speed of the train over the division. The sustained drawbar pull of an engine equals the sustained theoretical tractive effort of the engine less the effort of the engine lost to move itself and tender. The sustained theoretical tractive effort of the locomotive at a speed above 7 to 10 m.p.h. depends on the speed of the pistons at these higher speeds and the capacity of the boiler to furnish steam. This tractive effort, for a saturated or a superheated steam locomotive, is secured by the aid of the figures shown in Table I—first by calculating the piston speed of an engine in feet per minute at the speed at which the engine is to run over the ruling grade and then referring to Table I to determine what speed factor corresponds to the piston speed calculated. The product of the maximum theoretical tractive effort when multiplied by the speed factor will be the sustained tractive effort of the engine at the speed considered.

TABLE I

Speed Factors for Saturated Superheated Steam Locomotives at Various

Piston Speeds Ft. per Min.	Speed Factor	
	Saturated	Superheated
100.....	1.000	1.000
200.....	1.000	1.000
300.....	.954	.954
400.....	.863	.863
500.....	.772	.772
600.....	.680	.682
700.....	.590	.605
800.....	.517	.542
900.....	.460	.490
1,000.....	.412	.445
1,100.....	.372	.405
1,200.....	.337	.371
1,300.....	.307	.342
1,400.....	.283	.318
1,500.....	.261	.297

Next, it is necessary to make allowance for the power lost by the engine moving itself. This depends principally upon the weight of the engine in tons. The power lost by the engine lifting itself up grade is equal to twenty times the total weight of the

engine in tons times the grade in per cent. The power lost by the engine moving itself, i. e., rolling its own wheels on the rails, may be divided into three subdivisions:

- Resistance of drivers in pounds—
22.2 lb. times weight on drivers in tons.
- Resistance of trucks in pounds—
6 lb. times weight on trucks.
- Resistance of tender in pounds—
Resistance per ton of tender (see Table II) times weight of tender in tons.

If the locomotive is obliged to traverse a curve, then a further deduction of one pound per ton of locomotive per degree of curve should be made. Inasmuch as very high speeds do not enter into the consideration, it is not necessary to make allowance for air resistance to the locomotive.

All those various resistances, namely, that due to grade, drivers, engine trucks, tender, and curvature, are then added together and subtracted from the sustained tractive effort which the engine is capable of maintaining at the speed at which it is to negotiate the ruling grade. Mathematically the foregoing statement may be expressed in the following formula:

$$S. D. B. = \frac{.8 F P d^2 S}{D} - Wg (20g + 1 C) - 22.2 Wd - 6 Wt - r_e T,$$

- in which S. D. B. represents sustainable drawbar pull of engine in lbs.
- F — Speed factor of engine running at speed under consideration as determined from Table I.
- P — Maximum boiler pressure of engine in lb. per sq. in.
- d — Diameter of engine cylinders in inches.
- S — Stroke of engine cylinders in inches.
- D — Diameter of engine driver in inches.
- Wg — Total weight of engine and tender, fully loaded, in tons.
- g — Per cent of grade
- Wd — Weight in tons of engine on drivers.
- Wt — Weight in tons of engine on trucks.
- T — Weight of tender in tons, fully loaded.
- r_e — Resistance in pounds per ton of engine tender considered as a car (determined from Table II).
- C — Degree of curvature.

RESISTANCE OF TRAIN

Having found the drawbar pull the engine will sustain negotiating the ruling grade, it next becomes necessary to determine the weight of train this amount of drawbar pull will move up the grade at the speed desired. The resistance of a freight train depends directly on weight of the train, average weight of cars composing train, grade, curvature, speed at which train is required to move up grade, temperature, and wind.

Train resistance may be classified, generally speaking, under two heads: Internal resistance and external resistance.

The internal resistance of a freight train is that resistance which arises principally from the friction of the car journals, the rolling of the wheels on the rails, the friction of the wheel flanges on the rails, friction at side bearings, etc.

The external resistance of a freight train is that which arises from sources outside of the train itself and is principally composed of the resistance due to grade, wind and curvature.

Internal Resistance of Freight Trains.—The internal resistance of a freight train, or, more simply speaking, of a freight car, does not vary directly in proportion to the weight of the car in tons. For this reason an engine can haul more tonnage in heavily loaded cars than in light or empty cars. And so in loading freight trains, the adjusted tonnage rating system recognizes this feature and makes it possible to load each engine with tonnage according to the number of light or heavy or both kinds of cars composing the train. By referring to Table II it will be noted exactly how the internal resistance varies per ton of cars weighing 15 to 75 tons for different speeds.

The temperature of the atmosphere and the condition of the track affect this internal resistance. As the temperature decreases, or when the condition of the track is poor, the internal resistance is greater. Consequently, when determining the proper tonnage for an engine, these facts must be taken into consideration largely according to judgment. The figures given in Table II have been determined by a long series of tests at summer temperature on track which was in very good shape. Hence these figures should be used when determining the maximum train loads possible under ideal conditions.

External Resistance of Freight Trains.—The external resistance of freight trains or cars arises, as pointed out previously, from grade, curvature and wind. The grade resistance of freight cars is the same as that of locomotives, equaling per ton of car 20 times the per cent of grade. Curve resistance also is determined the same as curve resistance for locomotives. For purposes of tonnage rating under average conditions, an allowance of one pound resistance per ton of car for each degree of curvature has been found very nearly correct.

Wind resistance to freight cars is a variable quantity under usual railway operating conditions. Its effect is best determined

TABLE II
Value of Internal Resistance in Pounds per Ton Gross Weight of Freight Cars of Various Weights at Different Speeds

Weight of cars in tons	Pounds of Resistance per Ton of Car at Speed of			
	5 m.p.h.	10 m.p.h.	15 m.p.h.	20 m.p.h.
15	7.62	8.19	8.82	9.56
20	6.77	7.29	7.88	8.53
25	6.02	5.50	7.01	7.60
30	5.38	5.80	6.28	6.82
35	4.82	5.20	5.64	6.11
40	4.39	4.69	5.06	5.50
45	4.01	4.28	4.60	5.00
50	3.72	3.96	4.24	4.60
55	3.49	3.69	3.94	4.27
60	3.30	3.49	3.73	4.04
65	3.16	3.34	3.57	3.88
70	3.05	3.24	3.48	3.79
75	3.00	3.18	3.41	3.71

as a matter of judgment in the use of the various classes of ratings established (to be described later) according to the actual conditions existing.

External resistance is not affected by weather or temperature and does not vary practically except in direct proportion to the weight of the train. The length of the train has a little to do with curve resistance and wind resistance, but this influence on the whole resistance is too remote to be determined accurately.

The total resistance of a freight train per ton of car weight, as explained in the foregoing, may be summarized and expressed by the following formula:

$$R = Vc + 20g + 1C.$$

in which *R* represents total resistance in pounds per ton of freight car *Vc* represents internal or rolling resistance per ton of freight car, depending upon weight of freight car, as determined from Table II at speed under consideration; *g* represents grade, expressed in per cent and *C* represents degree of curvature.

DETERMINATION OF TRAIN WEIGHTS

The weight of train in tons which may be moved at a certain speed over a certain grade and curve is found by dividing the sustainable drawbar pull in pounds of the engine by the total resistance per ton of car. Mathematically expressed, this statement takes the following form:

$$\text{Weight of Train in Tons} = \frac{.8 F P d^2 S}{D} - \frac{W_G (20g + 1C) - 22.2 W_D - 6 W_T - r_c T}{V_c + 20g + 1C}$$

In order to demonstrate just how the hauling capacity of a locomotive varies according to the different weight cars making up the train, the following example will be of interest:

Consolidation locomotive.....	40,000 lb. maximum tractive effort
Grade.....	0.3 per cent
Average weight of light cars.....	20 tons
Average weight of heavy cars.....	70 tons
Speed of train up grade.....	10 m.p.h.

The sustainable drawbar pull of the engine at 10 m.p.h. on straight and level track, as determined by the method described, is 35,300 lb. Deducting for grade resistance on a 0.3 per cent grade, this sustainable drawbar pull becomes 34,220 lb.

The resistances per ton of a 20-ton and a 70-ton car at 10 m.p.h. going up a 0.3 per cent grade are as follows:

For a 20-ton car—	
Internal resistance (see Table II).....	7.20 lb.
Grade resistance (.3 × 20).....	6.00 lb.
Total resistance.....	13.29 lb.
For a 70-ton car—	
Internal resistance.....	3.24 lb.
Grade resistance (.3 × 20).....	6.00 lb.
Total resistance.....	9.24 lb.

Consequently the tonnages and number of cars which, under

most ideal conditions, this 40,000-lb. tractive effort Consolidation locomotive can pull over a 0.3 per cent grade at 10 m.p.h. in 20-ton cars (all lights or empties) and in 70-ton cars (all heavies or loads) are respectively:

In 20-ton cars, i. e., lights or empties—	
Weight of train.....	$\frac{34,220}{13.29} = 2,575$ tons.
Number of cars.....	$\frac{2,575}{20} = 129$ cars.
In 70-ton cars, i. e., heavies or loads—	
Weight of train.....	$\frac{34,220}{9.24} = 3,706$ tons.
Number of cars.....	$\frac{3,706}{70} = 53$ cars.

Thus it is seen that on a 0.3 per cent grade a 40,000-lb. tractive effort locomotive can pull 1,131 more tons in trains consisting of 70-ton cars than it can pull in trains consisting of 20-ton cars. When this fact is fully appreciated, the advantage of adjusting the tonnage of trains according to the average weight of all the cars making up the train is completely realized.

The more steep the grade becomes the less the difference in tonnages between the light car trains and heavy car trains. This is accounted for by the fact that as the grade increases the grade resistance, which is constant per ton for all cars, heavy or light, becomes a greater proportion of the total resistance and the rolling or internal resistance, which varies per ton inversely as the weight of the car varies, becomes less in proportion to the total resistance. This is another important fact and should be fully grasped so that it will be clearly understood why the adjustment for difference in car weights decreases as the ruling grade increases.

CAR FACTOR METHOD OF TONNAGE ADJUSTMENT

Having determined, as far as possible, the hauling capacity of a locomotive or class of locomotives over a division, after taking into consideration mathematically all the items which affect the problem, namely, train speed, grade, theoretical drawbar pull of engine, average car weights, curvature, etc., the final problem remains to find the best method of making up trains in the yard so that their tonnage will be equalized or adjusted to suit the hauling capacity of the locomotive. The best method by which this end is reached is the car factor method of adjustment.

This method simply provides for the addition of a purely imaginary figure, known as the car factor, to the actual weight of each car, including the caboose, entering into the make-up of a train until the sum of all the actual car weights plus their car factors equals the adjusted tonnage rating over the division of the locomotive to be loaded or rated. Knowing what actual tonnages and how many cars an engine or class of engines may pull over the grades of a division both in light or empty cars and in heavy or loaded cars, as determined mathematically by the process previously explained, it becomes a very simple matter to establish the car factor and the adjusted tonnage rating for the engine and division under consideration. The car factor equals the difference in the tonnages of the heaviest car train and the lightest car train the engine can haul, divided by the difference in the number of cars between the heaviest and lightest car trains. The adjusted tonnage for the engine equals the sum of the actual tonnage of the lightest car train and the number of cars in this train multiplied by the car factor, or, which is the same thing, the sum of actual tonnage of the heaviest car train and the number of cars in this train multiplied by the car factor. To illustrate, take the figures of tonnages and number of cars determined as the hauling capacity of a 40,000-lb. tractive effort Consolidation locomotive on a 0.3 per cent grade:

Weight of 70-ton car train.....	3,706 tons
Weight of 20-ton car train.....	2,575 tons
Difference in tonnages.....	1,131 tons
Number of cars, 20-ton car train.....	129
Number of cars, 70-ton car train.....	53
Difference in number of cars.....	76
Hence car factor on 0.3 per cent grade.....	$\frac{1,131}{76} = 15$

And so the adjusted tonnage for 40,000-lb tractive effort

engine under ideal conditions on 0.3 per cent grade, engine moving at 10 m.p.h., equals:

$$2,575 + (129 \times 15) \dots \dots \dots 4,510 \text{ adjusted tons.}$$

Or, which is practically the same thing:

$$3,706 + (53 \times 15) \dots \dots \dots 4,501 \text{ adjusted tons.}$$

This same theoretical analysis applies to any condition of grades and size of locomotive involved. If carried out for all grades varying from 0 to 2 per cent the car factors applying to each grade will be found as per Table III:

TABLE III

Car Factor for Different Grades	
Grades in Per Cent	Car Factor
0.0	70
.1	31
.2	20
.3	15
.4	12
.5	10
.6	8
.7	7
.8	6.5
.9	5.5
1.0	5
1.25	4
1.50	3.5
1.75	3.0
2.00	2.8

Thus it is seen that the heavier the grade becomes, the less the car factor grows, while, of course, at the same time the less the adjusted tonnage rating becomes.

The significant fact to be gained from the method of tonnage adjustment is that the actual weight of trains varies indirectly in proportion to the number of cars composing the train, and directly in accordance with the average weight of all cars composing the train. This is more graphically illustrated by Table IV, which is based on the figures developed for the adjusted

TABLE IV

How Train Tonnage Varies for Different Average Car Weights Considering a 40,000-lb. T. E. Locomotive on a 0.3% grade; Adjusted Tonnage, 4,500; Car Factor, 15

Average Car Weights in Tons	Actual Weight of Train in Tons	Number of Cars Composing Train
20	2,565	129
30	3,000	100
40	3,270	82
50	3,465	69
60	3,600	60
70	3,705	53

tonnage rating of a 40,000-lb. tractive effort. Consolidation locomotive on a 0.3 per cent grade.

REDUCTIONS FOR WEATHER AND OTHER CONDITIONS

Having determined theoretically and verified practically by previous locomotive performance records, special tonnage tests and dynamometer car runs, if possible, the maximum adjusted tonnage which can be hauled over a division, it finally becomes necessary to establish certain reduced ratings to guard against weather and other conditions which make reduced ratings necessary. It has been found most practical to provide four ratings for each class of engine between principal yard points or division terminals. These four ratings may best be designated by the letters *A*, *B*, *C* and *D*; the *A* rating being the maximum and the *B*, *C* and *D* ratings reductions from the maximum or *A* rating according to certain percentages dependent on the ruling grades.

Inasmuch as the temperature has the greatest influence on the resistance of trains, and hence the hauling capacity of locomotives, this is used as the basis on which to reduce the tonnage of trains from the maximum rating. Primarily a reduction in temperature only affects the internal resistance of trains, increasing it as the temperature drops. Consequently, the greater the proportion of internal resistance of a train, the greater is the effect of a reduction in temperature on the resistance of the train. In other words, the lower the ruling grade, the greater the proportional allowance must be from the maximum or *A* rating for a reduction in temperature.

What the exact allowance is that should be made for certain reductions in temperature under all conditions has never been proven exactly by experiment, and in reality hardly can be proven very accurately. Experience, however, determined in the light of reason, has shown the following temperature variations to be

satisfactory upon which to base reductions in tonnage from the maximum when making up trains:

- Maximum rating—Temperature above 40 deg. F.
- First reduction—Temperature below 40 and above 20 deg.
- Second reduction—Temperature below 20 deg. and above zero.
- Third reduction—All temperatures below zero.

For purposes of simplicity these various ratings may be designated as *A* or maximum and *B*, *C* and *D* respectively. Table V is given to show what has been found, in practice, to be satisfactory working reductions for temperature changes, based on increasing grades. It should be noted that as the grade increases,

TABLE V

Reductions in Per Cent to be Made From the Maximum or "A" Adjusted Rating for Decreases in Temperature

Grade in Per Cent	Reductions in Per Cent from Maximum or "A" Adjusted Ratings		
	Above 40°	40° to 20°	20° to 0°
0.0	0	13.70	27.40
.1	0	11.20	22.40
.2	0	9.70	19.40
.3	0	8.70	17.40
.4	0	7.98	15.96
.5	0	7.45	14.90
.6	0	7.00	14.00
.7	0	6.70	13.40
.8	0	6.42	12.84
.9	0	6.20	12.40
1.0	0	6.00	12.00
1.25	0	5.63	11.26
1.50	0	5.37	10.74
1.75	0	5.20	10.40
2.00	0	5.00	10.00

the amount of reductions from the heaviest rating grows less and less. The reason for this has been pointed out before and is sound logic, borne out by experience.

PRACTICAL CONSIDERATIONS IN DETERMINING MAXIMUM ADJUSTED TONNAGE RATING

Inasmuch as the maximum or *A* adjusted tonnage rating for an engine is the rating from which all the others are determined—that is, forms the basis for the ratings over a division—it is quite essential that this be established as nearly accurate as possible. It will most always be found, however, that the highest rating which is considered possible by mathematical calculation is either too high (most usually too high) or too low for practical purposes. Consequently, after the theoretical determinations have been made, they should always be fully tested out by actual tonnage tests under practical conditions. If the service of a dynamometer car can be had for this purpose it will assist materially toward proving the accuracy of the calculation.

The element of train speed, necessity to get from terminal to terminal in a certain time to get the greatest number of ton-miles per year out of an engine, is another very important practical consideration. It is difficult to determine generally what the most economical speed is at which trains should move over the division. To establish this speed and demand that it be lived up to at all times is a mistake, for the many conditions on a division which affect it are changing continually. It has been found by experience that the provision of four ratings, *A*, *B*, *C* and *D*, gives the division superintendent or division chief despatcher a sufficient number of ratings from which to choose for each day or each train, if necessary, in order to move the business best to suit the many influences which bear on this problem. And if the ratings are not sufficient, then special ones may quickly be established, according to the judgment of the official in authority, in order to meet special or emergency conditions.

The following brief explanations and instructions have been used with success by the author when he has had occasion to introduce the adjusted tonnage rating system on a railroad. They are repeated here by way of illustration:

The following two important facts and their effect on freight train operating economies will be appreciated from a study of the adjusted tonnage rating system. The first is the benefit resulting from making up trains so as to get as many loaded or heavy cars as possible into each one and thereby avoid running trains composed entirely of empty or light cars. This arrangement will often prevent the running of trains on which tonnage has had to be sacrificed on account of having reached the car limit before the train was filled out to the maximum adjusted tonnage.

The other fact which should be realized is the necessity of getting actual car and thus train weights as accurate as possible. The entire benefit from the adjusted tonnage rating system will be lost unless great care is taken in determining the actual car and train weights. To this end such means and systems at yard offices and at stations where cars originate for shipment should be introduced which will result in the greatest possible accuracy in determining actual car and train weights.

INSTRUCTIONS

- (1) All ratings are based on tons.
- (2) To determine the proper tonnage for an engine, find first from the rating tables the adjusted tonnage in effect corresponding to the engine. Then add the car factor to the actual weight in tons of each car. Finally, add together the weights of all cars plus their car factor allowance until the total equals the adjusted rating in effect.
- (3) To determine the proper tonnage for a pusher, double header, or three or more engine train, add together the adjusted ratings in effect for each one of the engines in question and proceed as outlined in paragraph 2.
- (4) When rating an engine, yardmasters and conductors will consider the caboose as one of the cars of the train, adding the

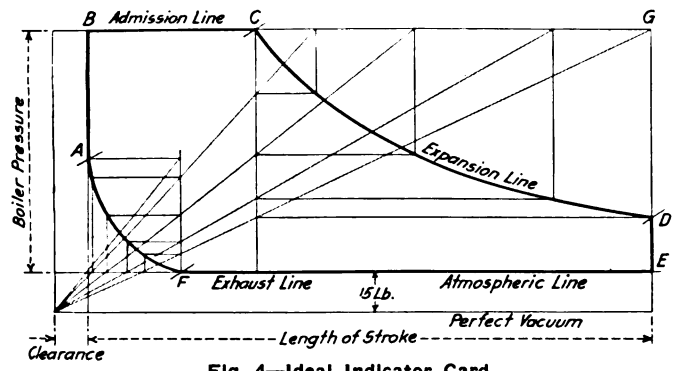

Fig. 4—Ideal Indicator Card

- car factor to the actual weight in tons of the caboose and this to the adjusted tonnage of the balance of the train, the total to equal the adjusted rating in effect, as outlined in paragraph 2.
- (5) When dead engines are hauled in a train yardmasters and conductors will add four times the car factor to the actual weight of each dead engine, and this to the adjusted tonnage of the balance of the train, the total to equal the adjusted rating in effect, as outlined in paragraph 2.
- (6) Yardmasters and conductors will add another light car to the train when the total adjusted tonnage of the train, including the caboose, adds up fifteen or more adjusted tons (that is a fraction of a car) less than the adjusted rating in effect.
- (7) Dispatchers, yardmasters and conductors will place as many loaded or heavy cars as possible in every train and avoid running any trains consisting entirely of empty cars unless otherwise instructed.
- (8) All classified freight trains as well as ordinary freight trains will be rated strictly on the adjusted tonnage basis.
- (9) No reductions in tonnage on account of weather or other conditions are to be made unless authorized by the superintendent.
- (10) Actual weights of empty or loaded cars must not be estimated or assumed when they are available from the car stencils or the way-bills.
- (11) When actual weights cannot be determined, the following estimates for weight of contents and light weights of cars are to be used, but not otherwise. Contents are to be estimated at the marked capacity of the car, except in case of light commodities, such as hay, cotton or bran, in which case the contents should be estimated at one-half the marked capacity. In the case of way freight (merchandise) cars, five tons will be used as the weight of the contents.

Light weights of cars to be estimated as follows:

Kind and Capacity of Cars	Light Weight (in Tons)
Box 40 ft., 80,000 lb. capacity	19
Box 34 ft. and 36 ft., 60,000 lb. capacity	16
Box 34 ft., 40,000 lb. capacity	13
Box 25 ft., 40,000 lb. capacity	10
Furniture 40 ft.	18
Furniture 50 ft.	21
Refrigerator	18
Refrigerator (meat)	21
Stock 30 ft., 30,000 lb. capacity	10
Stock 36 ft., 40,000 lb. capacity	11
Stock 36 ft., 60,000 lb. capacity	16
Double-deck stock	16
Plain flat 30 ft.	8
Plain flat 34 ft.	12
Plain flat 40 ft.	14
Plain flat 43 ft.	17
Coal cars 34 ft.	13
Coal cars 36 ft.	16
Hopper bottom coal, 80,000 lb. capacity	18
Hopper bottom coal, 100,000 lb. capacity	21
Rodger ballast cars	16
Ingoldsby dump cars	18
Tank cars	14
Caboose	15

(12) When converting the actual weights of cars from pounds into tons by dividing the actual weights in pounds by 2,000, yardmasters and conductors will in all cases neglect a remainder of 999 pounds or less, but will consider a remainder of 1,000 lb. or more as one ton.

DISCUSSION

The discussion was opened by J. M. Daly, formerly general superintendent of transportation of the Illinois Central, and an expert on tonnage rating, who spoke very highly of Mr. Beyer's paper. He believed that if in making up trains this system of adjusted tonnage were followed large economies in transportation costs would be made. He called particular attention to the fact that the resistance per ton of the loaded car is much less than that of the empty car. This of itself should justify the use of the adjusted tonnage rating system. He mentioned one road that had made a saving of 5 per cent by adopting this system. Overloading was considered more expensive than underloading.

Several members had found by experience that the short trains with the heavy loads hauled much easier than the long trains of light cars, even though the actual tonnage was much greater. It was generally believed that while a dynamometer car was of considerable advantage in determining the rating of a locomotive the work can be very satisfactorily performed by men experienced in the performance of locomotives and in this case the weight of the train should be carefully determined.

In helper service it is found to be much better practice to place the assisting locomotive at the rear of the train, especially if the grades are undulating and the curves are sharp. Mention was made by Prof. L. E. Endsley of the increase in train resistance due to badly worn wheel treads and loose trucks, the former being found, by test, to increase the resistance as much as 100 per cent. He also mentioned the necessity of keeping the wheel tires to the proper contour, stating that experiments have shown that wheels with no taper on the tread have materially increased the resistance of trains. Mention was also made of the fact that with the side bearings binding on loose trucks the wheels bind on the rails for some distance after passing a curve.

EFFECT OF VALVE GEAR ON LOCOMOTIVE OPERATION

W. E. Preston, Southern Railway, presented an interesting paper on this subject, in which he said in part:

In order to more readily explain any defects in a locomotive valve gear, as disclosed by the indicator, we will begin by examining the ideal indicator card, and for the sake of clearness we will first briefly outline this card for a non-condensing reciprocating stationary steam engine. Such a card is shown by the line in Fig. 4, indicated by the letters A, B, C, D, E, F to A. The construction is practically self-explanatory, the card being laid out to scale to represent the dimensions shown. Any cut-off may be chosen. Conditions applying to a locomotive require us to modify the ideal card outlined above in many respects. The valve gears are driven by an eccentric or its equivalent, the return crank—hence the functions of the valve are more or less

gradual and entirely interdependent on each other. There are also other influences besides the valve gear that materially affect the contour of an indicator card taken from the locomotive, the flow of steam being more or less impeded. We have, therefore, for the locomotive a card similar to Fig. 5.

Owing to the restrictions of the steam passages the pressure in the cylinder at admission will not be equal to the boiler pressure. The pressure during the portion of the stroke represented by *BC* will not be uniform for two principal reasons. The steam ports are, even when fully open, necessarily of limited area. At the beginning of the stroke the piston is moving comparatively slowly, while the valve, on the contrary, is at the quickest portion of the stroke, and is rapidly uncovering the port, and steam pressure is consequently at first fairly well maintained. As the point of cut-off is approached, the piston is, however, moving nearly at its maximum velocity, while the port is

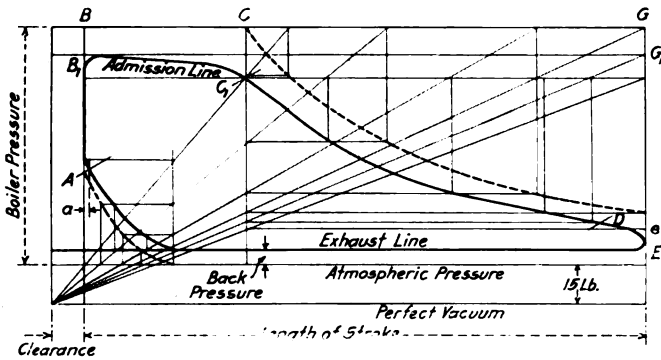

Fig. 5—Locomotive Indicator Card

being gradually closed by the valve, and the area available for admission of steam is gradually diminished. As a result the steam cannot enter fast enough to follow up the piston. It is, in fact, throttled at its entrance to the cylinder, and the pressure falls in consequence, so that the line *B₁ C₁* is no longer horizontal (for steam worked expansively), but drops as represented by the line indicated by the letters *A, B, C, D, E* to *A*.

Another cause of loss of pressure at the commencement of the stroke when the steam is worked expansively is the partial condensation of the entering steam, which takes place as it comes in contact with the sides of the port and walls of the cylinder, which have been previously cooled down by contact with the exhaust steam of the preceding stroke. It is sought to minimize this loss by keeping the cylinder hot by surrounding it with a jacket, by using superheat steam, etc.

The point of cut-off *C* instead of being sharply defined, as in

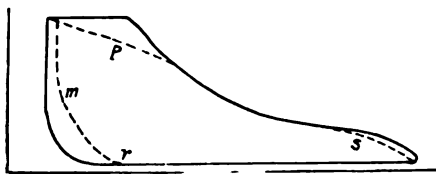

Fig. 6

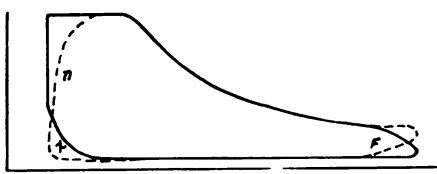

Fig. 7

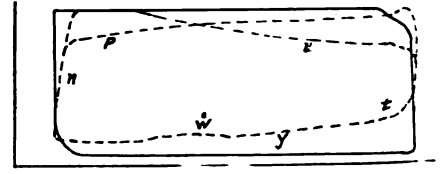

Fig. 8

Fig. 4, is usually rounded as at *C₁* in Fig. 5. This results from the very gradual manner in which the slide valve cuts off the steam, causing wiredrawing and fall of pressure at this point.

The actual curve of expansion of steam in the ordinary conditions of working of an engine is most complex, being, in fact, the resultant of a series of opposing condensations and re-evaporations. The final form of the curve for a given ratio of expansion is determined by the amount of clearance, by the dryness of the steam and the efficiency of the jacketing.

The exhaust is generally opened a little before the end of the stroke in order to allow the exhaust steam plenty of time to get away before the new stroke commences and in order to allow the port being pretty well opened at the end of the stroke.

The result is that the expansion curve terminates at a point *D*,

Fig. 5, and is succeeded by a rounded corner which is caused by the exhaust being throttled at first by the smallness of the aperture of the port when it commences to open. As the whole of the exhaust steam will probably not have escaped by the end of the stroke, instead of having the vertical line at *E* bounding the end of the diagram, we shall have a curved line.

The exhaust curve is different for each cut-off used, for as the point of cut-off on a locomotive varies, so does the point of exhaust opening—the earlier the one, the earlier the other, etc. This is quite an advantageous feature, as at high speeds the engine is worked with a short cut-off and the exhaust needs to be opened earlier in order to allow time enough to expel the steam during the quick movement of the valve. The point of exhaust opening even for slow speed and steam worked full stroke can never be quite at the line *GE*, Fig. 5. Hence the cut-off can never be 100 per cent. It is seldom over 85 per cent.

A locomotive has to have some back pressure to create the draft. In addition to this, there will be an increment of pressure due to the difficulty of expelling the steam from the cylinder through the ports and exhaust passages. Of course, the greater the back pressure, the greater the loss of efficiency of the engine, and excessive back pressure causes a very serious loss of efficiency which is readily noticeable in the amount of fuel used.

The amount of compression varies with the cut-off. The admission line begins usually at such a point as *A*, Fig. 5, in order to allow the admission port to be slightly open at the beginning of the stroke. Thus, *a*, Fig. 5, represents the lead.

The amount of Coal Used.—The amount of coal used is, of course, directly proportional to the amount of steam used, so that if we find the amount of steam used per horsepower hour as represented by any indicator card, we have a measure of the amount of coal used in doing the work represented by this card. Not all the steam generated in the boiler of a locomotive is used in the cylinders, neither is all the steam that is turned into the cylinders used in producing actual work, for a percentage of this steam is condensed in the cylinders and thus wasted. These losses are entirely immaterial to the comparison of different cards, as obviously it is fair to assume that with the same cut-off and speed the losses are the same for the two cards compared.

The indicated horsepower of a locomotive is represented by the following formula :

$$\text{Horsepower} = \frac{M \times d \times d \times L \times S}{375 D} \dots\dots\dots(a)$$

- M* = mean effective pressure as obtained from indicator card.
- d* = diameter of cylinder in inches.
- L* = length of stroke in inches.
- S* = speed in miles per hour.
- D* = diameter of drivers in inches.

If it is desired to turn this into tractive power, we may readily

do so. The ordinary well-known formula for tractive power is :

$$\text{Tractive power} = \frac{M \times d \times d \times L}{D} \dots\dots\dots(b)$$

The following formula gives the pounds of steam used per hour (for constant speed) :

$$\text{Pounds of steam per hour} = \frac{36.66 \times S \times W}{3.1416 \times D} \times (3.1416 \times d \times d \times f \times L + 4 \times C) \dots\dots\dots(c)$$

- S* = speed in miles per hour.
- W* = weight in pounds of a cubic foot of steam at pressure considered.
- f* = fraction of stroke piston stands at for pressure considered.
- D* = diameter of drivers in inches.
- d* = diameter of cylinders in inches.
- C* = volume of clearance space in cubic inches.
- L* = length of stroke in inches.

The pressure is taken from the indicator card at any point on the expansion line after cut-off has taken place and before the

exhaust has begun to open, as the steam is completely bottled up in the cylinder during this part of the stroke.

Distorted Indicator Cards.—There are many things that go to distort an indicator card, but a defect in the valve gear, or the setting of the valve gear, will at once become evident in the indicator card.

Figs. 6, 7 and 8 illustrate some of the defects due to faulty valve gear.

- P = Wiredrawing.
- m = Too much lead.
- r = Too early exhaust closure.
- s = Too early exhaust opening.
- x = Insufficient compression.
- n = Not enough lead.
- t = Late exhaust.
- u = Loose motion and wiredrawing.
- P = Lack of lap.
- y = Excess back pressure due to late exhaust.
- w = Blow.

These are the common defects due to the valve motion. Other defects, such as excess condensation, restricted ports, leaky valves, etc., are shown by the indicator card, but as these are not the fault of the valve motion they have no place here.

The card shown in Fig. 9 was taken from an actual test on a Consolidation engine having a Stephenson valve gear. It is a corner card, but the cut-off on this engine measured 87.5 per cent, whereas it should have been 85 per cent if properly set. The result of over-travel of the valve is clearly seen in the very late exhaust and lack of lead. From this card it is determined that 14.5 per cent more coal was being used than necessary at this point of cut-off. Moreover, the distorted motion reduces the maximum tractive effort of the engine some 3,000 lb.

Fig. 10 shows another card from the same engine hooked up to the sixth notch. Here the cut-off measured 73 per cent on the engine, while for this notch the ideal card gives 69 per cent. The straight line is the ideal card, the bent line showing the actual card. The valve still lacks lead and has too late exhaust opening, but the back pressure drops to normal at the admission

10 lb. at 20 m.p.h., or 15 lb. at 50 m.p.h., according to the best authorities.

As another example of a very poor card Fig. 11 is shown. This card is a very common one for valves poorly set. The line *ed* shows a lack of lead, the line *dc* shows the wiredrawing and slack motion effect of the valve in opening the steam port, while *cb* shows this effect for the closing of this port or at cut-off. The cut-off and expansion are normal, while *gf* shows a late and restricted exhaust, and *fa* shows that the exhaust port does not get fully open until the piston is at *a* on its return stroke—hence the high back pressure and resulting small compression.

As the expansion line for the length *bh* is the same for the good and bad cards, the amount of steam and coal used is, of course, the same for both cards. The coal consumption per horsepower hour, however, is increased 14.5 per cent.

DISCUSSION

From a fuel economy standpoint there seemed to be no preference between the Stephenson and any of the outside gears. It was the general opinion that the maintenance and accessibility of the outside gears, however, was much in their favor. Considerable was said concerning breakdowns to the motion work of the outside gear engines, and while some advocated completely cutting out the side of the engine affected, by removing the eccentric rod and the connecting link at the bottom of the lap and lead lever, others believed that better results would be obtained if it were possible to retain the motion to the valve derived from the crosshead, claiming that if the engine got on dead center this would materially aid in making a start. Some members advocated not clamping the valve in its mid position, claiming that as soon as the steam was admitted to the steam chest the valve would automatically center itself, and in case an engine stopped on center it could be moved over sufficiently to admit steam to the lame side, permitting the engine to start, the valve recentering itself after the first revolution.

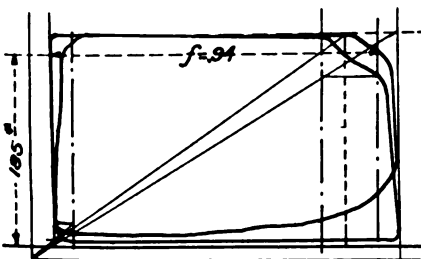

Fig. 9

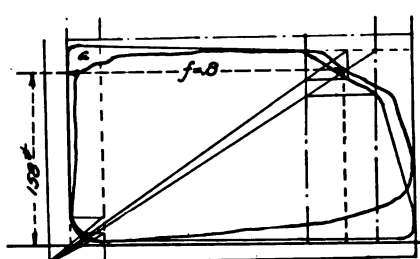

Fig. 10

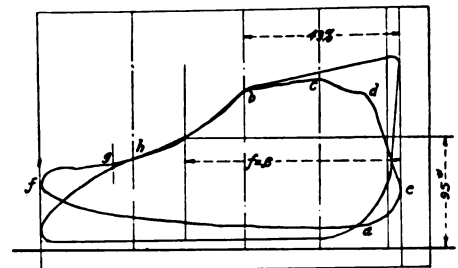

Fig. 11

end of the card. The effect of the slack in the valve motion is clearly shown at *a*. After the port gets fully open there seems to be very little throttling effect. This also applies to Fig. 9. Hence the port openings are ample.

The mean effective pressure for the ideal card is 167 lb., while for the actual card it is 156 lb., the increase in cut-off not being quite enough to compensate for the effect of late admission and exhaust. In this case there is 11.4 per cent more coal being burned than necessary to develop the same horsepower, the tractive effort being reduced 2,800 lb.

As the lead increases as the reverse lever is hooked back toward the center of the quadrant, we would expect the card of Fig. 10 to be better than that of Fig. 9. All of the events being earlier, the earlier release somewhat reduces the back pressure.

Theoretically the back pressure line should be parallel to the atmospheric line, and about the same distance from it for all cut-offs. At high speeds and short cut-offs, of course, more exhausts take place per minute than at slow speed, but to offset this we have a very much less volume of steam exhausted per stroke at high speed than at low speed. Practically, it is found that the back pressure increases slightly as the speed increases, the amount of condensation not being exactly constant at all speeds. However, the back pressure should not be greater than

ELECTRO-PNEUMATIC BRAKE

Walter V. Turner, assistant manager and chief engineer of the Westinghouse Air Brake Company, gave an illustrated lecture on the possibilities of the electro-pneumatic brake in the steam railway field. He called attention to the relation of the air brake to the power of the present day locomotive, showing how these powerful engines would be useless without the air brake to control them. The variable load brake has made possible to a still greater degree the heavier trains, the Virginian now operating trains of 8,000 tons with this type of brake. When considering the action of the air brake, the rail, the roadbed, the consist of the train and the foundation gear must all be taken into account, as they all have a definite bearing on how the brake will perform in service.

The piston travel is of prime importance, especially on long trains. It should be constant throughout the length of the train if "rough handling" is to be eliminated. Tests have shown that with an 8-lb. brake pipe reduction at the end of two seconds the cars with the proper piston travel (8 in.) will develop a braking power of 16 per cent, whereas those cars with a 6-in. travel of the piston will develop a braking power of 43 per cent.

which naturally causes very rough handling of the train. On long freight trains light applications should be made. This, of course, will increase the length of stop, but smooth handling will result. It should be remembered that the brake is four times as effective at 10 m.p.h. as at 20 m.p.h. and therefore the brake pipe reductions will have to be governed accordingly in making smooth stops.

In speaking of the clasp brake, he gave as a rough and ready rule as to when this brake should be used, the condition where the side pressure of the shoe exceeds the downward pressure of the wheel.

The purpose of the electrically-operated brake is wholly and solely to permit the use of a more efficient air brake. With the electrical control it is possible to have the brakes on all the cars in the train operate simultaneously rather than consecutively, as in the brakes controlled by the reduction of pressure in the train line; because of this feature the surging or the running in of slack, with its attendant disastrous results, will be eliminated and, at the same time, it will be possible to make use of a greater retarding force, thus materially decreasing the length of stop. Experiments have shown that the retarding force can be built up to 20 per cent with the electrically-operated brake, whereas the best pneumatic brake will permit of only 8 per cent retarding force—good train operation being obtained in both cases.

At the present time the electro-pneumatic brake is only available for passenger trains with electrical equipment. The amount of current required for the operation of this brake practically prevents its being used on freight cars in long trains.

Mr. Turner showed various diagrammatical illustrations of the electro-pneumatic brake and pointed out the versatility of the entire system. As many and as small applications of the brake can be made as desired, and the entire system can be recharged with the brakes set. The danger of "stuck brakes" is eliminated, the service and quick-action parts being entirely separate from each other. By its use passenger trains hauled by modern locomotives that have taken 18,500 ft. to accelerate to 58 m.p.h. have been stopped in less than 1,000 ft.

TRAINING OF MEN FOR FIREMEN

Nothing will so well repay the time and money spent as the education and development of railway employees in general and of locomotive firemen in particular. The locomotive firemen are using many million dollars' worth of coal, a great percentage of which is wasted through improper methods of firing and indifference to the fact that this coal represents so much money.

It is an admitted fact that the class of men employed as firemen during the past few years has not been up to the desired standard. We believe that the one thing which leads all others in causing lack of interest, and oftentimes real opposition against the railways, is the fact that in most cases the rank and file of the enginemen only know their superior officer through the chairman of the order to which they belong. The men and officials have grown apart until there is a great lack of confidence on both sides. The traveling engineer can be of the greatest help in regaining this lost confidence, if he has the proper backing.

Every company should have a distinct policy regarding the education and development of firemen from the day they are employed until they have passed all examinations to make them full-fledged engineers. This system should be as clean-cut and as vigorously maintained as the best of other operating systems are maintained. The new man should by all means have some special training before starting to fire a modern locomotive with its multitude of special appliances. He should be well grounded in the reasons for doing the work.

The work of educating the firemen should be placed in the hands of a broad-minded man who believes in this work, and is willing to give the best there is in him to it. He should have a practical knowledge of firing a locomotive and should thoroughly understand the burning of coal (or other fuel which may be used) on a locomotive. He should have a general knowledge

of all fuel used on the road and how it should be fired. He should have the knack of imparting his ideas to others on the locomotive or in class talks at terminals. Then, last, but not least, he should have the confidence of the officers of the road and be given full charge of the work, so that there will be no interference from any source.

Lesson papers should be prepared covering a course in elementary combustion, standard firing practice, boiler feeding, care of firebox on the road and at terminals, use of special equipment on the locomotive, rules and signals, instruction in safety first and locomotive-running and breakdowns. Class instruction should be given at the different terminals. The class-room should be fitted with a portable moving picture outfit. Several roads now use the moving picture and speak very highly of it as an educational item of great value. A dummy firebox of standard size and shape, equipped with a brick arch so that the conditions will be the same as on the locomotive, should be used for giving practical instruction.

The employing of new men is very important and should be given the attention of some one capable of judging and handling men. We would suggest the type of man wanted as locomotive fireman as one who is twenty-one years old, with a bright, clean-cut appearance. It is necessary that he should have a common school education and be able to assimilate instruction. He should have good habits, and if married, so much the better. Such a man will repay any time spent on him if he has the right spirit. The prospective fireman should be given a position around the roundhouse in some capacity, such as wiper, machinist helper, or on the cinder pit. If there are shops near or at the terminal, the new men can be placed there. With the men in the shops and in the roundhouse we will have them where we can start their education at once. There they will get experience which will be of great value to them after they get on the road as firemen and even after they go running.

When a man is employed he should be given a letter which will outline the position of the company with regard to his future. It will be explained to him that the company intends to educate him along the best lines of standard practice pertaining to his work; that if he will devote his time during working hours and some of his time out of working hours to the best interests of the company, the latter will give him an education in everything pertaining to his work as a fireman and as a future engineer; that the company expects, as a reasonable return, that the man will give, first, loyalty to the company's interest in every way, striving to promote the welfare of the company whenever possible; then, that he will do his work energetically and according to instructions. If these things are kept before the new man from the beginning, always showing him that the company is taking an interest in him, we will be able to combat a great deal of the other influence at work among the men.

By following this system you have picked men to start with. Then the company will have a chance to instill into their minds right thoughts about the position of locomotive fireman, and right thoughts about the position of the company toward the men. They will be ready to fire an engine from the start instead of probably never learning to fire. In the end it will give us a body of firemen on our locomotives who are interested in their work, who know how their work should be done, and who are looking forward to better positions on the road.

The report is signed by L. R. Pyle (M., St. P. & S. S. M.), chairman; J. C. Heyburn (St. L. & S. F.); J. C. McCutcheon (Wabash); J. Fred Jennings (M. C.), and W. H. Davies (Sou. Schools of Railway Science).

DISCUSSION

The members strongly favored some system of education, especially as under the present conditions engineers are not held responsible for the fireman, as was the case years ago. The new men are shifted around from crew to crew for their instructions, and it is necessary, in order to see that they are

properly instructed where no regular system is provided, that the road foreman make it his special duty to oversee their education. The new men should be made to feel that their superior officers are their friends, and all feeling of antagonism should be eliminated at the start. The men should have no occasion to refer to their schedule if they are treated fairly and squarely by their superiors.

In some cases the new men are started in the roundhouse as wipers, and in others they are tried out in switching service. The system of taking the first man that comes along when new firemen are required was believed to be a very poor system. The work should be made attractive, so that when the men are laid off they are always ready to come back. A. G. Kinyon, of the Seaboard Air Line, laid particular stress on the advantages of educating the men in the elementary principals of combustion, and advocated plenty of supervision to go along with the instruction on the road, claiming that the increase in supervision recently made on the Seaboard Air Line has shown a profit of over 2,000 per cent, due to the saving in fuel.

That the men may be properly chosen, applications in many cases are held for as long as six months to ascertain if they are the proper men for the work. B. J. Feeny, of the Illinois Central, spoke strongly in favor of the instruction car with the moving pictures. On that road the new firemen are given a good talk as to the pitfalls for the new men, such as garnisheeing, signing notes, etc., and they are given over to three crews for breaking in. They are then examined on the book of rules and given personal instructions in regard to handling the scoop.

On the Toledo & Ohio Central weekly meetings are held with the general foremen, the road foremen and such enginemen as are at liberty to attend. The condition of the power is considered, and it has been found that by following this practice the power has been materially improved. Fuel, lubrication, etc., are discussed, and in many cases the men request discussions of special subjects.

Mr. Pyle laid particular stress on the necessity of having the co-operation of the superior officers in any system of education. He strongly favored the starting of the instruction before the men are placed on the engine, and believed that if the men are treated fairly there could be no logical reason for the grievance committee to object to any system of education. He quoted from D. R. MacBain's address before the Fuel Association last May, which was printed in the *Railway Age Gazette, Mechanical Edition*, for June, page 271. Both the engineer and fireman should be congenial, in order that the best results may be obtained, and in case of complaints investigations should be made to see if they are well founded. Many times it will be found necessary to rearrange the engine crews. If no favoritism is shown, it will be possible to adhere strictly to the rules, with no complaint from the grievance committee.

SMOKE PREVENTION WITH OIL BURNING LOCOMOTIVES

When using oil as fuel the presence of smoke is as objectionable and expensive as with any other fuel; the causes may be classed under two heads: Condition of engine, and the manner of handling the engine by the crew. The principles of combustion as applied to the coal burner are applicable to the oil burner, as the fuels are very much alike in their chemical composition; however, the method of introduction into the locomotive furnace is entirely different. At first thought it may appear that the liquid fuel offers more advantages favorable to complete combustion than the solid fuel, but this is not proved in practice.

The cause of smoke is always incomplete combustion, due either to insufficient supply of air or a reduction in temperature, and forcing the fire will produce one or both of these conditions. If the draft holes and front end apparatus are of proper size and their adjustment is correct, a good open nozzle can be used. With a clean boiler and a moderate draft the time for combustion and heat conduction through the sheets and tubes to the water is extended and the desired evaporation can be

attained without resorting to a high firebox temperature. This condition would mean lower smokebox temperatures and but very little smoke.

The use of too much brick work in the firebox reduces the amount of heating surface, which means a higher firebox temperature will be necessary. The formation of carbon in the firebox causes much smoke and wastes much fuel. Carbon is formed by allowing the oil spray from the burner to strike some object in its path before it reaches the draft holes. Pieces of brick, piles of sand, or waste, if allowed to fall in front of the burner, obstruct the spray and the small globules of oil are reassembled thereon. Combustion at this point is incomplete and carbon forms. If the obstructions are not removed the accumulation of carbon continues until the terminal is reached.

The location of the burner at least 5 or 6 in. above the bottom of the firebox will cause the spray to pass over small objects in the bottom of the firebox and prevent the formation of carbon and smoke. Much smoke is made while firing up engines at terminals, due to the fact that the fire is forced hard. One hour and thirty minutes should be consumed getting the engine hot, and this would result in quite a fuel saving and less smoke.

An engine crew possessing a general knowledge of the principles of oil combustion can by close attention to their duties do much to prevent smoke formation. There is no good reason why an oil-burning engine should be worked any harder to handle a train than a coal burner should, but as the oil burner requires no great physical exertion by the crew, it is often abused.

The report is signed by Martin Whelan, chairman.

DISCUSSION

While it was believed that smokeless firing could be obtained with oil-burning engines, it was pointed out that far greater care must be given to the mechanical operation of firing. Unless the fireman follows the operation of the throttle, which affects the draft, very closely, a large amount of smoke will result. It is also necessary that the locomotives be maintained in first-class condition and have a proper distribution of air into the firebox. Leaking steam pipes, leaking flue sheets, improper construction of the firebox, insufficient air supply, improper atomization of the oil, all contribute toward making smoke on oil-burning engines. The brick work in the firebox, especially the brick arch, must be so constructed that there will not be an excessive localization of the heat, which in some cases has resulted in burning off the seams and buttonhead rivets.

The heavy oils should be thoroughly preheated, both in the tank and before they pass out of the burner, to insure perfect atomization. Where steam from the turret is used to atomize the oil it is necessary to have perfectly dry steam, as otherwise the flame is liable to be extinguished, causing explosions, which sometimes blow down the arch. The arch and brick work should be far enough away from the burner to insure the complete combustion of the oil before it strikes the surfaces of the brick work. Oil-burning engines must be fired properly. This will require plenty of competent supervision, as it is very easy for the fireman to become careless in controlling the amount of oil fed to the firebox. The use of the deeper ash pans, which give greater furnace volume, have proved very satisfactory. It is, of course, desirable to keep the firebox at as uniform a temperature as possible, and for this reason when engines come in from the road and are placed in the roundhouse the stacks should be covered in order that the boiler may cool down gradually.

HANDLING OF THE AIR BRAKES

There is no discounting the value of the air brake instruction car, because by it many experiments can be made of the working parts of the system. In connection with the influence train braking and train control have on railroad operation, the road foreman of engines, it is believed, can and should be of the greatest value. As a rule, road foremen of engines, with their assistants, are practical engineers and should be as thoroughly

posted in the air brake, its construction and manipulation as any other part of the machinery and operation in their charge. Possession of a thorough familiarity with the air brake system should permit the road foremen of engines, in their routine work, to explain and demonstrate practically to the enginemen in their charge what is necessary for the best train control. The road foreman undoubtedly has a great opportunity, by reason of his constant road duties, to observe and pick out the men in his territory who will be benefited by special instructions, either as to construction or manipulation.

Smooth train service is very generally dependent on the braking system and its proper manipulation. While good brake manipulation is necessary on the part of the engineer, there is no doubt that the road foreman by the closest observation should be able, through the master mechanics, foremen, repairers and inspectors, to exert the greatest influence toward securing the most favorable conditions possible under the circumstances by co-operation and by pointing out results developing on the road as well as what might be done to improve train operation.

The road foreman of engines, with his thorough knowledge of the road, its grades and train operation, is able to furnish valuable information to the train despatchers, train masters and superintendents with reference to the handling of trains, best meeting points on the division, speed of trains over different portions of the road, the most advantageous location for sidings, switches, signals, water tanks, etc., all influenced to a very great degree by his knowledge of the possibilities in train service and appreciation of train control.

In the engine we have a tremendous reserve power to damage and destroy equipment unless it is carefully handled in starting and stopping, and by careful manipulation of the engine and air brake system good results can be accomplished. Where defective triples and inefficiently braked cars have escaped the inspector, the road foreman of engines may be in the best position, through the co-operation of the engineman, to bring back to the shops and inspection points such object lessons for better service that can in no other way be successfully secured. However careful the shop people may be toward maintaining the equipment, and however diligent those responsible may be in an effort to instruct enginemen in the construction, operation and manipulation of the air brake, the road foreman of engines occupies the position offering the greatest opportunity to lend the most valuable assistance for the best work in the handling of trains, which will result directly in higher efficiency in train service, maintenance of equipment, besides affording more comfortable passenger train service to the traveling public.

The road foreman of engines should direct his interest not only in the handling of engine crews and movement of trains on the road, but should study the construction of the locomotive, its operation, along with the economical use of fuel and supplies, so as to bring back to the mechanical department, being their only representative on the road, any subjects and mechanical matters developing in operation that seem to be open to further improvement.

The road foreman of engines can be of the greatest assistance to the mechanical department and shop people by instructing the enginemen on the road how to make the proper inspection of their engine, and what information should be looked for and the character of reports of most value. In conclusion, we recommend that the road foreman of engines regard the instruction car or exhibitions as a part of his "work shop," and take every opportunity to completely master the subjects that are therein offered for study in such a way as to be better able to explain the system and its operation to the men on the road, illustrating to them what is possible and how it can be best accomplished.

The report is signed by C. M. Kidd, chairman (N. & W.); T. F. Lyons (N. Y. C., West); Geo. Kleifgas, J. B. Hurley (Wab.), and C. P. Cass, (W. A. B.).

DISCUSSION

In order that the road foremen may properly instruct the en-

ginemen in the handling of the air brakes they should see that the repair forces keep the brakes in proper condition. It was believed that it was the duty of the road foremen to instruct in the practical side of operating the brakes rather than to attempt to go into the mechanical details, leaving that to the air brake instructor. A large amount of patience must be exerted by the man instructing the enginemen in the use of air brakes. It has been found to be rather difficult to establish any hard and fast rules for the operation of trains, there being many circumstances arising that will not exactly make the hard and fixed rule practical. Where men have difficulty in handling their trains on certain sections of the road they can be referred to other engineers who operate over the same division and in the same class of service, and who do not experience any trouble. All the mechanical men should bring their influence to bear on the yardmasters, in order to have the trains properly made up. The light, empty cars should be distributed throughout the train among the loads, as otherwise, if they are bunched at the rear break-in-tuos are liable to result, and if they are bunched in the head end of the train buckling will be caused. On the Erie a difference in pressure in the train line between the front and rear ends is not permitted to exceed 10 lb. Several roads follow the practice of publishing damage reports showing the causes of the accidents and the damage done, with suggestions, if possible, as to how these accidents may be avoided. These cases are investigated for the good of the service. It was believed to be the best practice to place pusher engines on long trains between the caboose and the train.

SUBJECTS

The following subjects were recommended for consideration at the next convention:

What effect does the mechanical placing of fuel in fireboxes and the lubricating of locomotives have on the cost of operation?

The advantages of the use of superheaters, brick arches and other modern appliances on large locomotives, especially those of the Mallet type.

Smoke prevention.

Make up of freight trains for tangents and grades with reference to draft rigging and lading.

Assignment of power to obtain the most efficient service.

CLOSING EXERCISES

Favorable action was taken on the recommendation that arrangements be made with the International Railway Fuel Association for the holding of the conventions of the two associations consecutively for the purpose of permitting those who are members of both associations to attend the conventions with a reduction in the amount of time these members are absent from their roads. The matter was left to the executive committees of both associations for final adjustment.

Warren S. Stone, grand chief, Brotherhood of Locomotive Engineers, was elected an honorary member of the association.

The attendance was 404 members; the secretary reported a membership of 1,061, and the treasurer reported a cash balance of \$7,500. The following officers were elected for the ensuing year: J. R. Scott, president, St. L. & S. F.; B. J. Feeny, first vice-president, Illinois Central; H. F. Henson, second vice-president, N. & W.; W. L. Robinson, third vice-president, B. & O.; G. A. Kell, fourth vice-president, Grand Trunk; A. G. Kinyon, fifth vice-president, S. A. L.; David Meadows, treasurer, M. C., and W. O. Thompson, secretary, N. Y. C.

Chicago received the highest number of votes as the place for holding the next convention.

COVERING STEAM PIPE FLANGES.—In covering steam piping it is often the practice to omit the covering from the flanges and sometimes from the valves and fittings. While the heat thereby lost may or may not represent an item equal to the cost of the covering and labor, the expansion and contraction effect will eventually result in damage to the piping.—*Power*.

NEW YORK CENTRAL SMOKE-WASHING PLANT*

BY M. D. FRANEY

Master Mechanic, New York Central, Elkhart, Ind.

The New York Central engine house in Chicago is located at Englewood station, near Indiana avenue and 63d street. It is adjacent to the White City, a popular amusement park, and surrounded by a very desirable residential district. The citizens are very insistent on the abatement of smoke, and object to the excessive use of the blower which is sometimes necessary for this purpose. While the New York Central locomotives west of Buffalo are equipped with the steam jet smoke consumer, which induces a flow of air above the fire and under the brick arch, and large blower capacity consisting of two 1¼-in. blowers, one on the right and one on the left side, it is found that these appliances are of little assistance in the elimination of smoke when building a new fire in a cold locomotive. This was the great problem which confronted the mechanical officers of the New York Central in 1910, when it was found necessary to build a new engine house and terminal facilities at the Englewood station.

O. M. Foster, master mechanic in this territory at that time, after a careful study of smoke-washing devices, which had been tried at other places with partial success, conceived the idea of

ent smoke washer at Englewood was designed and constructed. The only drawback was in securing material that would withstand the powerful action of the various acids resulting from the combination of the gases, the solids and water.

The Englewood engine house has 30 stalls, in which from 80 to 100 locomotives are handled every 24 hours. It is built without a single smoke jack leading direct to the atmosphere. In washing the smoke, a large concrete tank is used, 22 ft. by 32 ft. This is subdivided by separating walls into three basins, each of which is lined on the interior with dressed lumber set in about 1½ in. from the concrete. The space between the concrete and the lining is filled with tar. Wooden pins, instead of nails, are used for fastening the lining, in order to resist the action of the acids. The drawings show the plan and elevation of the tank, the stack, the three hoods, the three ducts connecting the fan with the concrete basin, the fan and motor and the elbow connecting the fan with the large smoke duct in the engine house to which the smoke jacks connect.

A large smoke duct, 60 in. in diameter at the center and tapering to 36 in. at the ends, extends around the engine house just under the roof and directly above the smoke stacks of the locomotives when the latter are headed in and standing in normal position. This smoke duct was built of transite material, and is connected with drop pipes leading down to each pit. In each of these drop pipes is a damper which is closed when

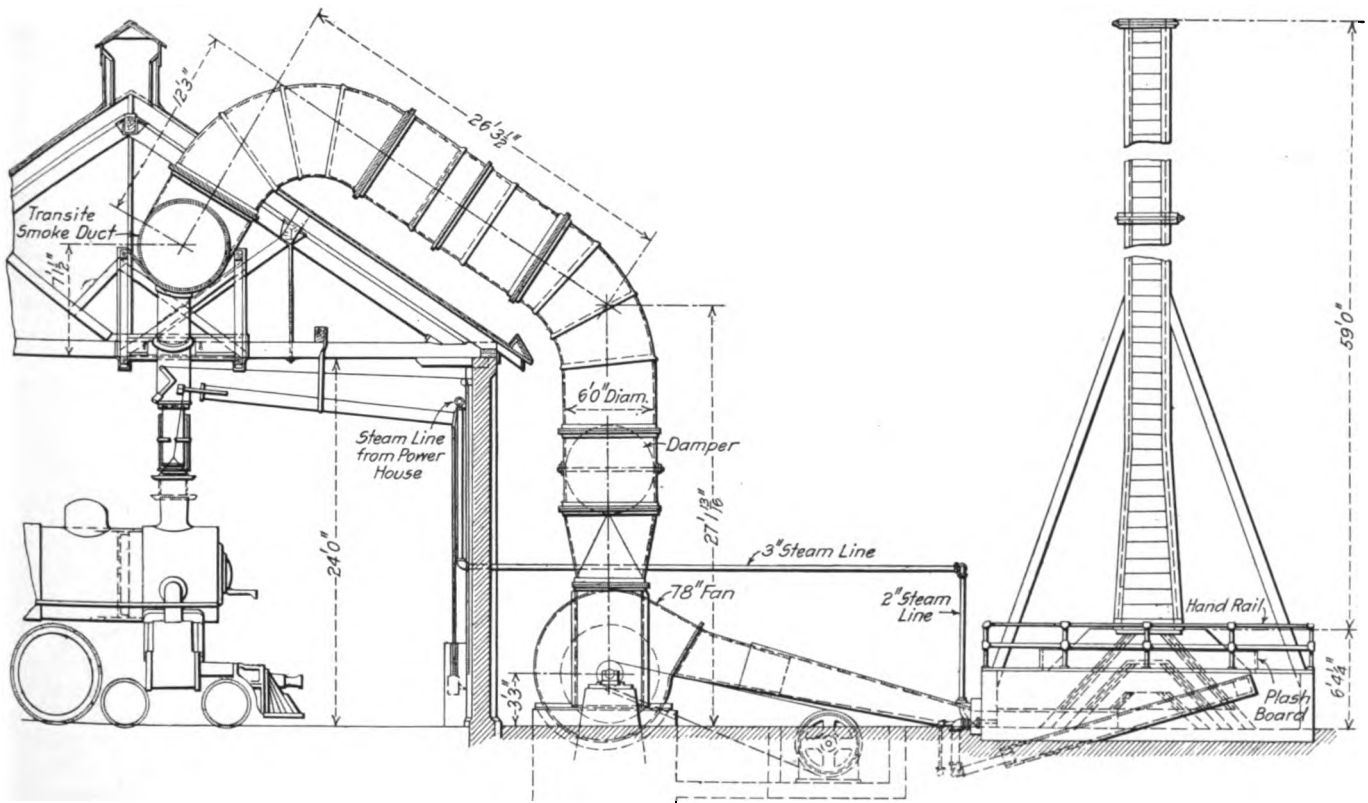

Locomotive Smoke-washing Plant at the Englewood Engine House

forcing the smoke through a large body of water by means of a fan, separating the unconsumed carbon from the gas, permitting the latter to escape through a high stack and holding the carbon and other solids in suspension in the water. D. R. MacBain, superintendent of motive power, who had made a life-long study of smoke-abatement devices, approved of the plan. A small plant was built at Elkhart, Ind., capable of taking care of one locomotive, which gave results beyond expectation. To more thoroughly test the device, an experimental plant was built at Collinwood, Ohio, to take care of several locomotives. With the data collected from this experimental plant, the pres-

the jack is not in use. Leading from each drop pipe is a telescopic jack made of cast iron and supported from the roof. These telescopic jacks have vertical, lateral and longitudinal movement to accommodate different positions of the locomotive stack. They are raised and lowered by a walking beam, counterbalanced with a weight and operated from the wall of the engine house. The damper is opened and closed from this same point.

Near the center of the house a large elbow connects into the top of the 60-in. transite duct and leads down to a 78-in. steel plate, double-inlet fan, capable of handling 68,000 cu. ft. of gases per minute at 500 deg. at a total static pressure of 14 in. at the fan outlet, and at a speed of 950 r.p.m. The fan is belt-driven by a 300 hp. constant speed, 300-400 r.p.m. motor. A smoke duct

* From a paper presented at the tenth annual convention of the International Association for the Prevention of Smoke.

leads from the fan to each of the three concrete basins, the outlet to each duct coming directly under the hoods referred to above. There are three hoods in each tank. The top of the interior hood is open, while the top of the second hood is closed similar to a bell; the top of the third or outer hood is open and connects with the stack, which is approximately 60 ft. high. The three smoke ducts leading from the fan, the hoods and the stack are made of wood pinned together with pegs instead of nails. The lower portions of the three hoods extend down in the concrete basin and are submerged in the water.

An 8-in. hole is provided in each of the separating walls to insure a uniform level of water in the three basins. A special

to, the gases are engulfed by the spray and wave action of the water and pass out through the top of the first hood into the second hood or bell, which, it will be remembered, has a closed top. They are forced down below the lower edge of this hood and pass to the third hood, and out of the water into the stack.

The carbons and solids are separated from the gases as they are forced through the water and rise to the top of the water in the tank in the form of a black, foamy scum. The gases pass out through the stack as a white vapor, practically odorless. In handling 80 locomotives in 24 hours, from 8 to 10 barrels of carbon are obtained from the smoke washer. This has the appearance of lampblack, and is thoroughly steam-dried

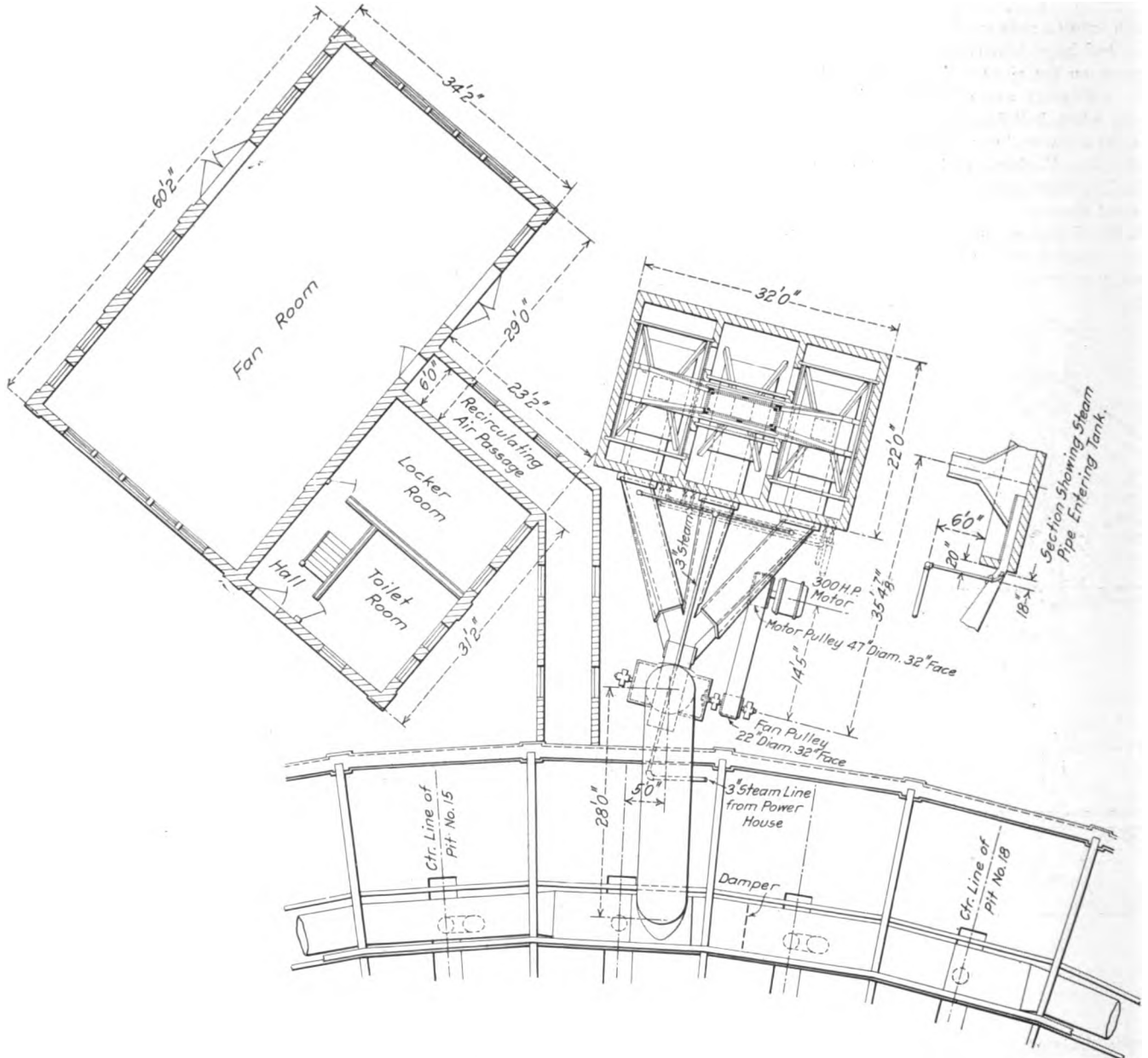

Plan of Locomotive Smoke-washing Plant at the Englewood (Chicago) Engine House of the New York Central

overflow pipe is provided to maintain 14 in. of water in the tanks and to prevent the carbon from escaping into the sewer. A 1¼-in. high-pressure steam jet, with proper elbow and nozzle pointing toward the outlet, is located in each of the three ducts and close to the concrete tank. The purpose of these steam jets is to accelerate and thoroughly mix the gases with the water and prevent them passing through the water in large bubbles. The gases are forced from the fan through the three smoke ducts into the water, passing out into the first hood. The water being thoroughly agitated at this point by the steam jets referred

after it is taken from the smoke washer. An analysis of this material is as follows:

Moisture	3.9 per cent
Carbon	82.6 per cent
Sulphur	2.6 per cent
Iron oxide	8.7 per cent
Silica	1.8 per cent
Calcium oxide	trace

The sulphur and sulphuric acids are retained in the water. The city smoke department of Chicago and the nearby residents are well pleased with the results obtained and on numerous occasions have complimented the plant very highly.

The estimated cost of making such an installation is from \$15,000 to \$18,000, where the property conditions are favorable. Owing to the property conditions and to the fact that the Englewood plant is an experimental one, the actual cost was somewhat greater. We made an investigation some time ago as to the cost of operation:

COST OF OPERATION PER DAY OF 24 HOURS

Water, 18,255 gallons, @ 7 cents per M.	\$1.28
Coal, 10.86 tons, @ \$1.75 per ton.	19.00
Electricity, 3,360 kilowatt hrs., @ \$0.0129.	43.34
Total	\$63.62

SAVING EFFECTED BY THE USE OF WASHER PER DAY OF 24 HOURS.

Fires maintained	\$40.80
New fires built	7.11
Reduced electrical cost due to sliding scale rate.	8.52
Total	\$56.43

This makes the net cost of operating the washer \$7.19 per day of 24 hours (\$63.62 less \$56.43). It is expected that we will be able to find a profitable use for the lampblack reclaimed by the smoke washer. This would, of course, result in still further decreasing the net cost of operation and might possibly show a profit.

We have found that where the fires are properly started the draft from the fan is sufficient to draw off the gases from the locomotive without the use of the blower. This means a decided reduction in the amount of water used, due to not using the steam blower, and also means a decided saving in coal consumption, due to the reduced draft. While we have quoted the results of some tests, it is difficult to obtain a set figure as to the amount of coal and water consumed by an engine at a terminal, due to varying conditions, such as smoke restrictions, temperature of the weather, and the human element or fire-up men. However, the tests showed to our entire satisfaction that the coal and water consumption is materially reduced on engines stored under the smoke jack and influenced by the draft of the smoke washer fan. The temperature of the firebox is more even and the fire-up man is able to handle a larger number of locomotives.

This smoke washer is operated under patents controlled by the American Smoke Washing Company, incorporated in Illinois, of which S. K. Dickerson, 5120 Greenwood avenue, Chicago, is secretary.

PREPARED PAINTS FOR METAL SURFACES*

BY HENRY H. GARDNER

Assistant Director, The Institute of Industrial Research, Inc.,
Washington, D. C.

In designing protective coatings for metal the modern practice has been to apply the results available from researches into the cause of corrosion. These results have shown that materials of a basic nature, or substances which contain soluble chromates, prevent the rusting of iron. For this reason pigments of a basic nature or pigments containing the chromate radical have come into wide use in the manufacture of protective paints. That they are the best pigments for this purpose has been proved not only in practice, but also in the Atlantic City tests,† which were made on a series of 300 large steel panels, using nearly 100 different pigment paints. Applying the results of these tests to the practical manufacture of protective coatings, the writer will discuss the use of the various pigments under separate headings, taking up the composition of the most widely used colors for metal painting, namely, red, gray, black and green. Most of the paints outlined herewith are suitable for the painting of structural steel, bridges, steel

railroad cars and equipment, ornamental ironwork, poles, posts and for general work on metal surfaces.

Red Lead Priming Paints.—It is well understood that one of the most valuable properties of red lead is its ability to set up to a hard, elastic film that shuts out moisture and gases which are apt to cause corrosion. This cementing action is due to the presence of unburnt litharge, a pigment which rapidly reacts upon linseed oil to form a lead linoleate compound. It will readily be seen, therefore, that red lead free from litharge has no cementing action and should not be considered more protective than iron oxide or any other similar neutral pigment. It is thoroughly essential that red lead should be highly basic and should contain a considerable percentage of litharge, if it is to protect iron from corrosion. It is a growing custom to use prepared red-lead paints made from finely divided red lead ground to a fluid condition in linseed oil. Such paints remain in excellent condition for a long period of time. They have a high protective value and are well suited for general purposes. They are used extensively for priming steel vessels. The Navy Department has found that inert pigments, such as silica and asbestine, give good results when used in ready mixed red-lead paints, their action being to prevent settling of the red lead upon storage.

A specification which may be used by the grinder when purchasing dry red lead prepared paints is given herewith:

1. The dry pigment to be the best quality, free from all adulterants, and to contain not less than 85 per cent nor more than 90 per cent Pb₃O₄, the remainder being practically pure lead monoxide (PbO).
 2. It shall contain not more than 0.1 per cent of metallic lead, nor more than 0.1 per cent of alkali figured as Na₂O.
 3. It shall be of such fineness that not more than 0.5 per cent remains after washing with water through a No. 21 silk bolting-cloth sieve.
- NOTE.—If desired, the gram weight of the red lead may be specified. Extremely light, fluffy red lead should run from 10 to 13 grams per cubic inch. Medium red lead will run from 13 to 16 grams per cubic inch. Heavy red lead will run from 17 to 19 grams per cubic inch.

Composition of Red-Lead Priming Paints.—The cost of red-lead paints is a subject of vital importance to the large user. Red lead may be produced in different physical states. Ordinarily the grade that has been overburned is extremely heavy, 1 cu. in. weighing from 18 to 20 grams. For the production of a paint from such red lead, according to the formula used by one large consumer, the following quantities would be required:

Red lead	26 lbs.
Linseed oil	26 gills
Petroleum spirits	3 gills
Drier	3 gills

This would produce approximately 1 2/5 gal. of paint. Each gallon would contain about 20 lb. of red lead, the actual cost of the red lead itself being in the neighborhood of \$1.60. A red lead of a much better protective value, containing from 10 to 12 per cent of free litharge and produced in an extremely fine physical state of comminution, so that 1 cu. in. would not weigh over 12 to 15 grams, would produce a paint of exactly the same body on the following formula:

Red lead	20 lbs.
Raw linseed oil	26 gills
Turpentine	3 gills
Drier	3 gills

This would produce approximately 1 1/3 gals. of paint, each gallon of which would contain about 15 lb. of red lead, the actual cost of the dry pigment per gallon being in the neighborhood of \$1.20. Red lead of still lighter gram weight could be used, so that a still smaller quantity of pigment would be required per gallon of oil. The durability of such paints should compare favorably with those containing very high percentages of red lead of high gram weight. Pigments of an extremely light nature, such as lampblack, grind in very large quantities of oil, yet their films are more elastic and durable than many paints which are composed of much pigment and little oil.

Red Paints.—Iron oxide has always been one of the most widely used pigments for the manufacture of protective coatings. Oxides that are free from acid or soluble substances give the best results. There are many grades, from the bril-

*Presented at the Forty-sixth Annual Convention of the Master Car and Locomotive Painters' Association.

†For full description of tests and further information see Proc. Amer. Soc. for Test. Mater., Vol. IX, 1909, pp. 203 and 204; Vol. X, 1910, pp. 79-86; Vol. XI, 1911, pp. 192-194; Vol. XIII, 1913, pp. 369-371; Vol. XIV, 1914, pp. 259 and 260.

liant Indian reds, containing 98 per cent, down to the natural mined brown shale oxides, containing from 30 to 60 per cent of ferric oxide, the balance being silica, clay, etc. Venetian reds, consisting of about equal parts of ferric oxide and calcium sulphate, are also quite widely used. It is customary to add to iron oxides from 10 to 20 per cent of zinc chromate, zinc oxide, or red lead, in order to make them rust inhibitive. Such red paints are widely used for application to tin roofs, metal siding and general structural steel. Red paints made from basic lead chromate (American vermilion), the pigment which gave the best results in the Atlantic City tests, would doubtless be the most economical in the long run, but the high cost will probably prevent their use to any great extent. The use of a percentage of basic chromate of lead in iron-oxide paints is to be approved.

Gray Paints.—Mixtures of white lead (basic carbonate or basic sulphate) and zinc oxide, tinted gray with carbon black, are widely used and give excellent results in every climate.

A valuable rust-inhibitive coating for general priming or finishing work may be prepared from sublimed blue lead. The use of two parts of blue lead and one part of linseed oil containing about 5 per cent of turpentine drier makes a paint of the right consistency. This may be purchased in prepared form. The rust-inhibitive value of this pigment is due to the high percentage of lead oxide (litharge). When purchased ground to a paste in 10 parts of oil, there should be added approximately 5 gals. of linseed oil and 1 pt. of drier for use. A specification for blue lead for use in metallic paints is given herewith:

	Minimum	Maximum
Lead sulphate.....	44 per cent	52 per cent
Lead oxide.....	33 per cent	40 per cent
Lead sulphide.....		0.5 per cent
Lead sulphite.....		3.5 per cent
Zinc oxide.....		3.0 per cent

Black Paints.—Black paints are often preferred for the finishing coat on steelwork, carbonaceous paints being unsuited for application direct to the metal on account of their rust-stimulative action. Carbon pigments, such as gas carbon black, oil black, artificial and natural graphite (flake and amorphous) are usually the base pigments used in black paints. Silica and other earth pigments may be combined with the carbon. The slow-drying nature of such paints is lessened by the addition of litharge. The use of boiled linseed oil as a vehicle is advisable.

Magnetic black oxide of iron (precipitated) forms an excellent black protective paint when ground in linseed oil. The slightly basic character of this pigment accounts for its inhibitive value. The natural variety of black magnetic oxide of iron is also suitable for this purpose, but should be tested for freedom from soluble acid impurities before use. Willow charcoal is not made in commercial quantity; its use, therefore, will be restricted. Its inhibitive value depends on the basic nature of the impurities present.

Green Paints.—Mixtures of zinc chromate and Prussian blue in oil are highly inhibitive and have proved satisfactory in long service tests. Chrome yellow tinted with black oxide of iron to an olive shade is permanent and protective. Chrome green made from lead chromate and Prussian blue is generally used when precipitated upon a barytes base.

Painting Galvanized Iron.—Roofing, siding, railing, drain pipes, cornice work, etc., constructed of galvanized iron require painting if they are to be kept in a good state of preservation. Paints are apt to peel from galvanized iron on account of the smooth, spangled surface. This condition, however, is obviated by first treating the metal before painting with a solution of copper salts. Such a solution may be prepared by dissolving 4 oz. of copper acetate, copper chloride or copper sulphate in one gallon of water. By brushing on this solution the galvanized iron is roughened, a thin deposit of copper being plated out over the surface. After an hour or so, the surface may be lightly brushed and then painted with a thoroughly

inhibitive oil paint. Firmly adhering films are thus produced.

Painting Tinned Surfaces.—Tin plate, such as is used for roofing and siding, will rapidly corrode unless protected by paint. The pin-holes present in the tin coating on the steel base metal act as pockets to catch moisture, which causes rust spots and pit-holes. Before applying paint to the sheets it is advisable to rub the surface of the tin with a cotton rag saturated with benzine or turpentine. This will remove the palm oil that is present on the surface and allow the paint to firmly adhere. Iron-oxide paints containing an inhibitive pigment are widely used for preserving tin. The use of 15 to 20 per cent of zinc oxide, red lead or zinc chromate with a neutral bright iron oxide produces an excellent paint. The partial use of boiled linseed oil or kauri gum mixing varnish will add to the gloss and water resistance. Such paints are also suited for use on metal shingles and pressed-steel siding—plain black, galvanized or tinned. For dipping purposes, turpentine or high boiling point mineral spirits should be used for thinning. Cheap driers containing a low boiling point benzine should be avoided.

EXHAUST INJECTORS

BY ROBERT W. ROGERS

Instructor of Apprentices, Erie Railroad, Port Jervis, N. Y.

Exhaust steam from the cylinders has been used for some time in British practice for injecting the feed water into the boiler, either alone or in combining with live steam. Injectors of the combination type are sometimes made in two sections, and sometimes the two parts are combined in one body. The drawing shows the two parts of the former type separated, that at the right being the exhaust steam section and that at the left the live steam section.

The exhaust steam section takes the feed water from the tender at atmospheric temperature and raises it nearly to the boiling point. In addition to the heating effect a pressure of 70 lb. per sq. in. is exerted on the water, and it is delivered at this pressure and temperature to the live steam section, which forces it into the boiler. With injectors of this type the temperature of the water delivered to the boiler reaches 270 deg. F.

Automatic action is attained in this type of injector by the construction of the combining tube. This tube is divided longitudinally into two parts, the upper part being hinged to the

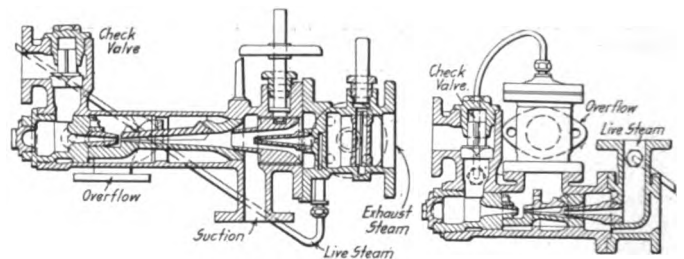

The Exhaust and Live Steam Sections of a Combination Type Injector

lower. When in operation the tube acts as a unit in the usual way, but when the jet breaks the two halves of the tube are forced apart, thus affording a temporary free outlet which is required to re-establish the normal action of the injector. A small pipe extends from the live steam section to the exhaust section through which live steam is supplied in small quantities to the exhaust section in order that it may be operated when the locomotive is standing or drifting. In starting the self-acting injector the steam and water supply valves are opened and the water supply is regulated by a valve in the suction pipe until the overflow ceases.

In the development of the exhaust injector it has been found that, owing to the presence of oil in the exhaust steam, the feed pipes rapidly become choked up; a grease cap or separator is therefore generally provided in the exhaust steam line, which removes the oil from the steam before it enters the injector.

CAR DEPARTMENT

DESIGN OF STEEL PASSENGER EQUIPMENT

BY VICTOR W. ZILEN

Associate, American Society of Mechanical Engineers

II

SPRINGS

Considerable information is available on the design of springs and the laws governing strength and flexibility are well known. The effect on physical properties, however, of heat treatment and other variables leads to some speculation on the part of designers as to just what should be the proper allowance for fiber stress in order to obtain the most economical sections. It is common practice to allow 80,000 lb. per sq. in. under maximum static load. No doubt this could be exceeded if scientific treatment in manufacture is carried out with precision.

The method so long used of shaping springs by hand, quenching them in oil and afterwards toughening them by slow heating and gradual softening, the high temperatures being determined by color as seen by the spring maker's eye, is extremely uncertain. The results obtained are not fully satisfactory, because much depends upon the susceptibility of the retina to light as well as upon the degree of illumination under which the observation is made. New methods are gradually coming into general use in which the furnace temperatures are maintained under close regulation and accurately measured, but some unreliability probably still exists, and unless the various appliances are checked up from time to time and kept in order they may possess no advantage over the older method. However, the car designer is interested in the results obtained from the spring rather than the method of its manufacture, and since few roads have modern appliances for the repair of springs, the writer feels that 80,000 lb. per sq. in. may still be considered the maximum safe unit stress under static load.

Many formulas are found for the calculation of elliptic and semi-elliptic springs, all of which are based on the same fundamental principles. The formula of Realeaux is quite generally used. For semi-elliptic springs this formula is

$$P = \frac{S n b h^2}{6L} \dots (21)$$

$$D = \frac{S l^2}{E h} \dots (22)$$

in which

- P = static load on one end.
- L = 1/2 span in inches less 1/4 width of band.
- S = stress lb. per sq. in.
- b = width of plates, in.
- n = number of plates.
- E = modulus of elasticity = 29,400,000.
- h = thickness of plate (should be about .02L).
- D = deflection.

For full elliptic springs *D* has twice the value given above. The formula assumes that the edge of the band is ineffective. The ratio of full-length plates to the whole number required is 1/4; the last full-length plate should be tapered at the ends and the remaining plates regularly shortened and tapered. The length of the shortest plate should not be less than twice the length of the spring band.

In car work the dimensions of springs are limited by available space, and a length of about 40 in. between centers is seldom exceeded. For ideal operation the point of suspension should be chosen so that the ratio of the static to the dynamic loads will be the same as the predetermined ratio of the allowable static and dynamic fiber stresses, but for practical reasons a point in line with the journal bearings is preferable. Space between bands must be such that when springs are solid the stress may be well within the elastic limit.

In the discussion of axles, it will be remembered that the value

of *H* was found by formula (11) to be 17,277 lb. This is the centrifugal force, due to the weight on one axle, acting at its center of gravity and for a given speed varies directly as the weight producing it. For any portion of the car the value of *H* acting at its center of gravity may be found by simple proportion. In Fig. 2 let

*H*₁ = the horizontal force required at the center of gravity of the weight above the springs.

H = 17,277 lb.

*W*₁ = 52,000 lb. = weight on springs including weight of passengers.

W = weight on one axle = 31,000 lb.

The value of *H*₁ will then be found as follows:

$$H_1 = \frac{W_1 H}{W} = \frac{52,000}{31,000} \times 17,277 = 29,000.$$

Taking moments about *C*, the intersection of the vertical and horizontal center lines of one of the springs, we have for equilibrium of the car above the springs:

$$P_2 l + H_1 a_1 = \frac{W l}{2}$$

$$P_1 + P_2 = W_1.$$

From this the loads on the springs are found to be

$$P_2 = \frac{W_1}{2} - \frac{H_1 a_1}{l} \dots (23)$$

$$P_1 = \frac{W_1}{2} + \frac{H_1 a_1}{l} \dots (24)$$

The latter becomes

$$P_1 = \frac{52,000}{2} + \frac{29,000 \times 46}{76} = 43,600 \text{ lb.}$$

when the following values are substituted:

a = 70 in.

*a*₂ = 24 in.

*a*₁ = *a* - *a*₂ = 70 - 24 = 46 in.

l = 76 in.

From this it is seen that the load per group of springs due to combined vertical and horizontal forces may be found by (24) and the space between bands may be proportioned accordingly.

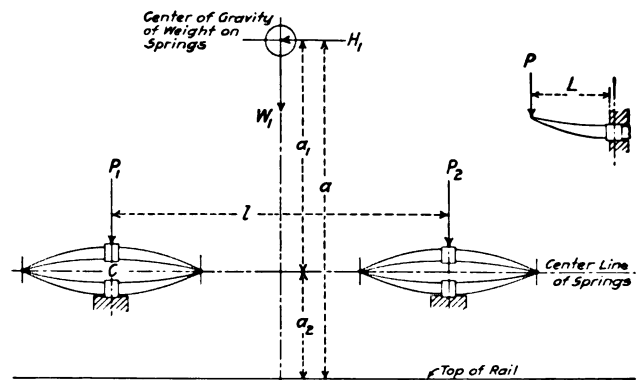

Fig. 2

For the given values *P*₁ was found by formula (24) to be 43,600 lb., while the static load per group of springs is 26,000 lb. From formula (21) we know that stress *S* varies directly as the load *P*. Then let

*P*₂ = 26,000 lb. maximum static load per group of springs on one side of the truck.

*P*₁ = 43,600 lb. maximum load due to vertical and horizontal loading combined.

*S*_s = fiber stress for static load.

*S*_c = fiber stress when springs are solid = 120,000 lb.

Then solving for the fiber stress under static load

$$\frac{S_s}{S_c} = \frac{P_2}{P_1} \text{ or } S_s = \frac{P_2 S_c}{P_1} \dots (25)$$

$$S_s = \frac{26,000 \times 120,000}{43,600} = 71,600 \text{ lb. per sq. in.}$$

If we wish to make *S*_s = 80,000 lb., *S*_c would be 134,000 lb., which probably is too high for safety, and unless the value of

P_1 , as affected by the position of the springs, can be reduced, the values of 71,600 and 120,000 for S_s and S_c should be used.

HELICAL SPRINGS

What has been said in regard to manufacture, arrangement, position and dimensions of elliptic springs is equally true in the case of helical springs. In case of a four-wheel truck, the springs should be as close to the journal box as possible, the top of the box being the most preferable location, for the reason that it is the point of reaction for all the loads. A lighter spring may therefore be used at this point than at any other location.

It is considered good practice not to have the diameter of the rod from which the spring is to be made more than one-quarter the outside diameter of the spring, and when placing one spring on the inside of the other they should be coiled right and left. The maximum fiber stress allowable is between 80,000 lb. and 90,000 lb. when the spring is compressed solid. This should occur only when the maximum condition of loading is reached. This condition may be determined by the same procedure followed in deriving formulas (24) and (25) for elliptical springs. Referring to Fig. 2,

$$H_1 = \frac{W_1 H}{W}$$

in which

W_1 = say 30,500 lb. = weight on springs including weight of passengers.
 H = 17,277 lb.
 W = weight on axle = 31,000 lb.

In this case W_1 is one-half the weight above the coil springs on one truck, since there are four sets of coil springs. Substituting these values

$$H_1 = \frac{30,500 \times 17,277}{31,000} = 17,000 \text{ lb.}$$

and if the following values for the dimensions shown in Fig. 2 are used

a = 66 in. from top of rail to the center of gravity of the weight on helical springs.
 a_2 = 26 in. from rail to center of springs.
 a_1 = 40 in.
 l = 76 in.

the values of P_1 and S_s may be determined by formulas (24) and (25)

$$P_1 = \frac{30,100}{2} + \frac{17,000 \times 40}{76} = 24,000 \text{ lb.}$$

$$S_s = \frac{15,050 \times 90,000}{24,000} = 56,400 \text{ lb. per sq. in.}$$

In this case the maximum fiber stress of the springs when solid is 90,000 lb., which limits the fiber stress under the static load to 56,400 lb.

To secure an easy riding truck the total deflection for helical and elliptical springs combined should be as liberal as practical conditions will permit, the limit being the maximum side sway a car may have sidewise at eaves without exceeding the clearance line of tunnels, bridges, etc.

The required dimensions for helical springs will be found by the following formulas:

$$P = \frac{S \pi d^3}{16 r}, \dots\dots\dots(26)$$

$$f = \frac{4 S r^2 \pi h}{G d^2} \dots\dots\dots(27)$$

in which

G = 12,600,000.
 P = load at solid height in lb.
 S = stress in lb. per sq. in.
 d = dia. of steel in in.
 r = radius of center of coil in in.
 h = solid height of spring in in.
 f = deflection in in.

In obtaining the deflection for one inch of solid height $h = 1$, and may be omitted in (27). Formulas (26) and (27) may be simplified by letting $\frac{\pi S}{16} = c$ and $\frac{4 \pi S}{G} = k$. Substituting c in (26) and k in (27)

$$P = c \frac{d^3}{r} \dots\dots\dots(28)$$

$$f = k \frac{r^2 h}{d^2} \dots\dots\dots(29)$$

$S = 80,000, c = 15,708, k = .08$ $S = 90,000, c = 17,672, k = .08976$
 $S = 85,000, c = 16,700, k = .0847$ $S = 95,000, c = 18,650, k = .09474$

The following table gives values of the constants c and k for values of unit stress from 80,000 lb. to 95,000 lb.:

S	c	k
80,000	15,708	.08000
85,000	16,700	.08470
90,000	17,672	.08976
95,000	18,650	.09474

THE CAR DEPARTMENT AND THE EXPEDITING OF PREFERRED FREIGHT

M. J. O'Connor, special inspector of the New York Central, read a paper on "Ways and Means of Expediting Movement of Cars Loaded with Preferred Freight" at the September meeting of the Niagara Frontier Car Men's Association at Buffalo, from which the following is taken:

The car department is a prime factor in the prompt and safe movement of freight trains, and I will endeavor to describe from a car department point of view what the contributing elements are:

(1) By covering the inspection and necessary light or running repairs to cars at freight houses and industrial plants prior to loading the cars it will avoid marking them to repair track later on, or holding them for necessary repairs after they are received in train yards; as a result trains can be gotten out of terminals with a minimum delay.

(2) The inspection of the air brake apparatus and the adjustment of brakes in the receiving yard, also the marking out of all cars on which the air brakes are not in perfect order, assists materially when making the final air brake test after the road engine is coupled to train in the classification yard. It is a feature of the inspection that should be given special attention, as it is an acknowledged fact that where this is done it has been the means of reducing the number of burst air hose en route, and the consequent damage to equipment, likewise serious delay to trains.

(3) Treating the journal boxes of cars after they are assembled in trains will disclose whether the packing and contained parts are in the best possible condition. Where this practice is followed conscientiously it will reduce the trouble experienced with hot boxes to a minimum. While this is a failure the railroads have always had to contend with, I have no hesitation in stating that by specializing on this work the trouble with hot boxes can be reduced fully 40 per cent.

(4) Co-operation with train crews is most important from the fact that when cars are moving over the line they are beyond the jurisdiction of the car inspector. This co-operation can be established to a better degree and understanding by having inspectors in a special capacity ride the important freight trains. as this not only brings to light any irregularities, but is a means of educating the train crews to the nature of defects on cars; should a slight defect develop while en route they are thus better qualified to know whether the car is safe to move to a terminal, which knowledge will prevent the unnecessary cutting out of cars carrying preferred freight.

IMPORTS FROM GERMANY.—Imports from Germany into the United States for May, 1915, were only \$3,172,630, compared with \$14,661,923 in May, 1914. The largest item was toys at \$447,976, the next being earthen, stone and china ware at \$225,758.—*Iron Age*.

HIGHER LINESHAFT SPEEDS.—In many factories, the lineshafts run too slowly and consequently most of the machines provided with cone drives are so speeded that the slowest speeds obtainable on the machine are seldom or never used. A Connecticut manufacturer of machine products has set a good example by speeding his lineshafts so that the slowest speeds that can be obtained on any machine are the slowest that ever will be required. The general effect has been to use higher speeds on all work from the lowest turning speed to the highest filing speed.—*Machinery*.

NORTHERN PACIFIC PASSENGER CARS

Example of Standard Construction for Various Classes of All-Steel Passenger Train Cars

The Northern Pacific has recently received from the Pullman Company 47 coaches, 22 mail and express cars, 17 baggage cars and 6 dining cars of all-steel construction, 10 of the baggage cars and 4 of the mail and express cars being equipped with the head end generator sets of which two were of the axle machine train

Length over end sills (Dining Cars)	72 ft. 10 in.
Length over end sills (Other Cars)	70 ft. 10 in.
Width over side sills	10 ft. 13 1/2 in.
Rail to top of floor	4 ft. 5 3/4 in.
Truck wheels, number and diameter	6—36 in.
Journals	5 in. by 9 in.

The weight of the coaches is 141,100 lb.; the mail and express

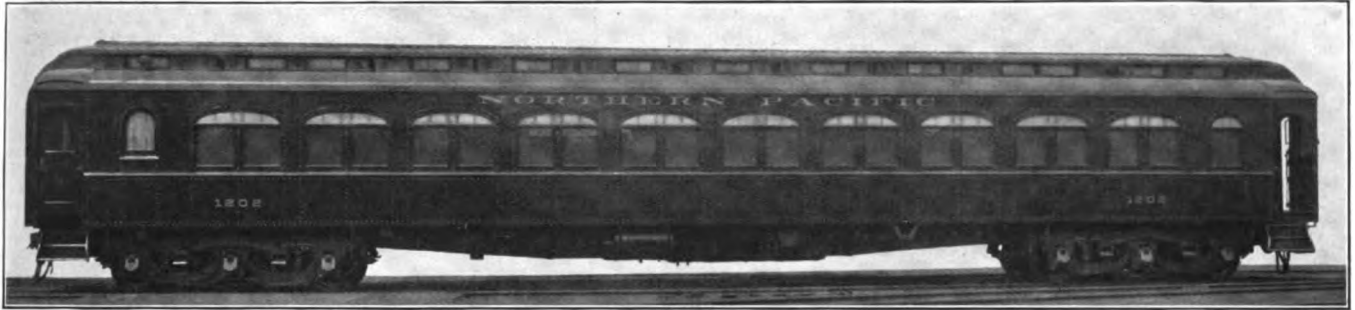

Northern Pacific All-Steel Passenger Coach

lighter type. The interesting feature of these cars is the marked similarity in their construction. The trucks are identical, the underframe practically so, and the framing only different in characteristic details, the coaches and diners being designed to carry

cars, 140,300 lb. without, and 146,200 lb. with the lighting dynamo; the baggage cars, 127,800 lb., without the lighting dynamo, and 139,800 lb. with, and the dining cars, 160,100 lb. The coaches have a seating capacity of 84, and the diners 30. Vestibule ends

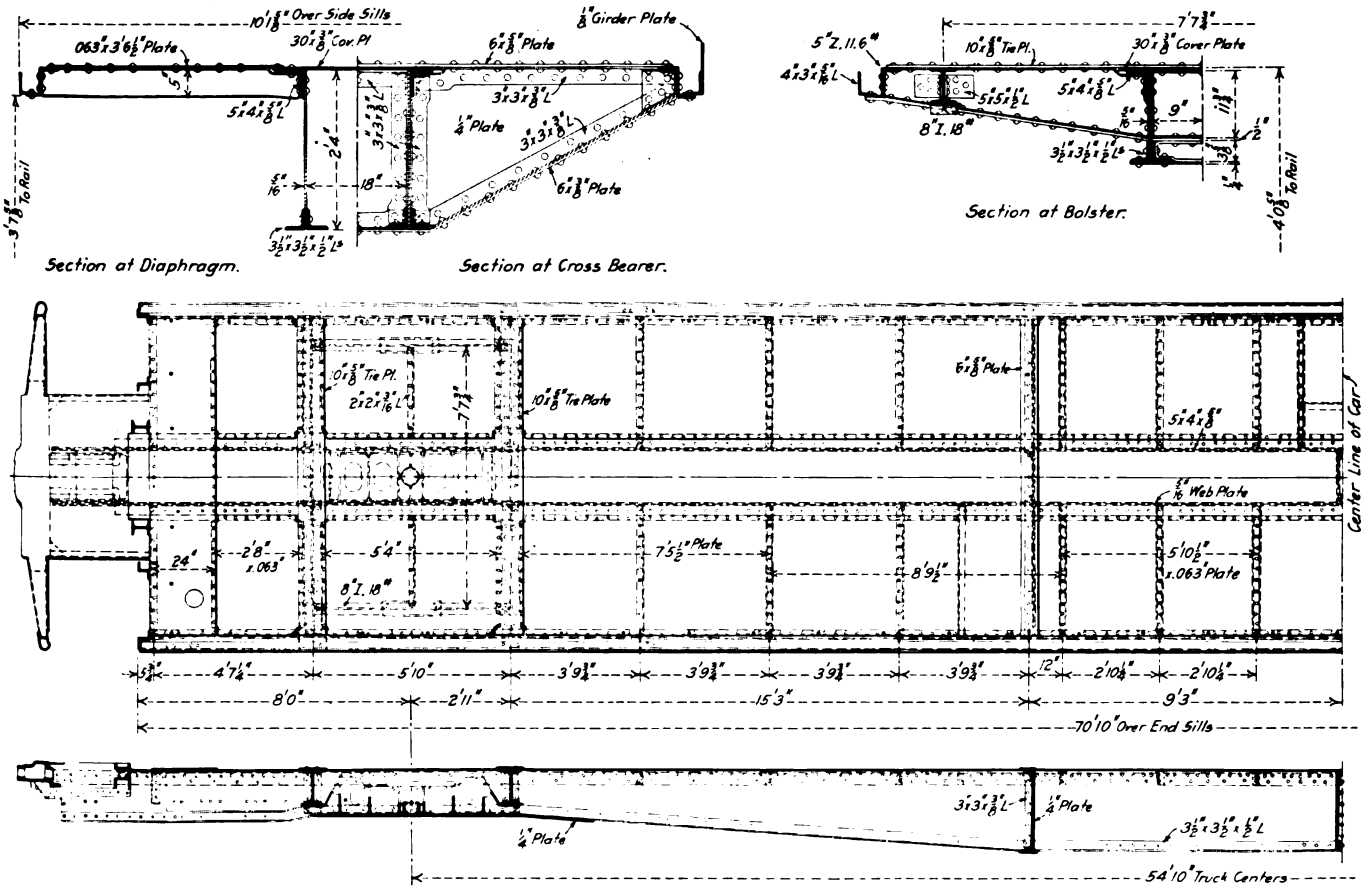

Underframe Construction of Northern Pacific Passenger Cars

a live load of 20,000 lb. and 18,000 lb. respectively, and the other cars 50,000 lb. Many of the Northern Pacific standard parts were used and, where possible, steel castings were used in preference to forgings. The cars all have the same general dimensions, which are as follows:

are used on the coaches and diners, the side doors and steps being wider than usual. The other cars have stub ends.

The coaches have a natural Mexican mahogany finish from the window sills to the lower head lining and 7/16-in. fireproof Agasote below the windows to the baseboard. The ceiling is

of the half empire style, with 3/16-in. fireproof Agasote head lining finished in pearl color with gold stripes. The diners are finished in Cuban mahogany with the exception of the kitchen, which is finished in plain oak. Agasote is used below the window sills and on the ceiling, which is of the full empire style. It

red color in the coaches to harmonize with the inside finish. The baggage and the mail and express cars have an inside sheathing of 13/16-in. by 5 1/8-in. poplar, with a ceiling of 3/16-in. Agasote. A 1 1/8-in. poplar partition separates the dynamo compartment from the rest of the car. All of the baggage and the

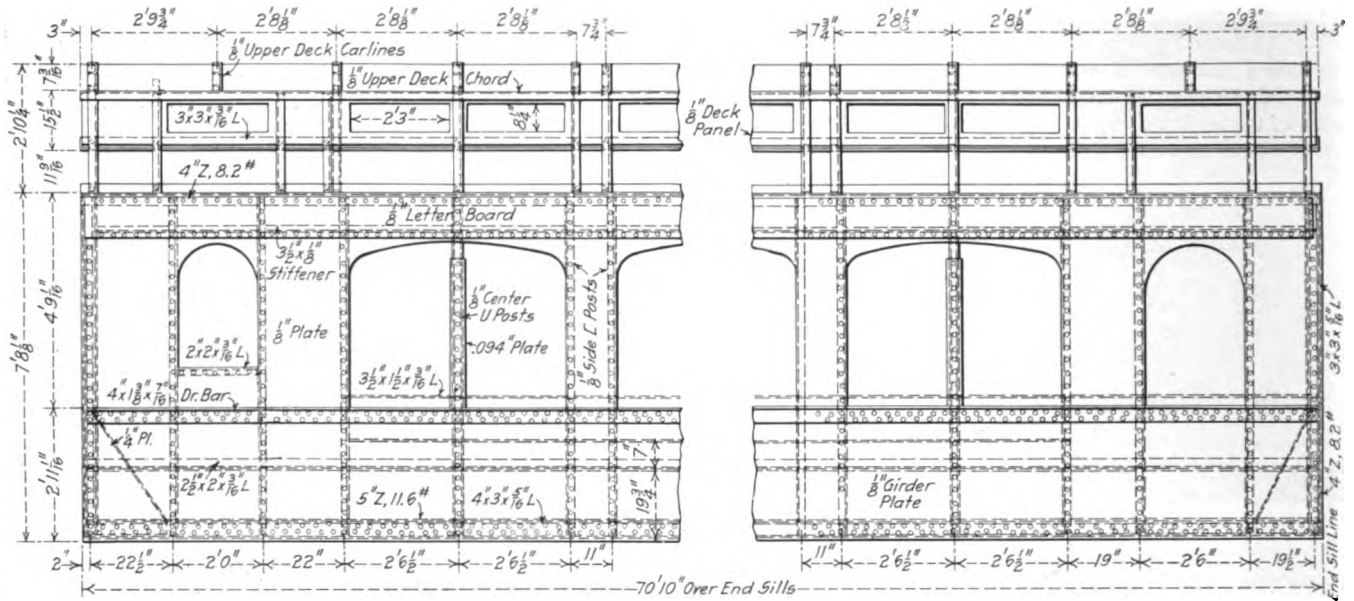

Side Frame of Northern Pacific Coaches

is decorated in pearl color with gold stripes. Pressed prism plate glass embodying the Northern Pacific monad emblem design at the center is used for saloon, deck and gothic windows of the coaches and diners. On the coaches the prism glass was applied both inside and outside at the gothics, while in the dining-room of the diners the space usually taken by the gothics was incorporated in the main window, making the clear glass 36 in. high by 47 in. wide. These large and extra high windows are particularly adapted to afford unobstructed views. The oval aspect of the windows, which is the Northern Pacific standard for wooden cars, has been maintained in these cars. The flooring in

mail and express cars not equipped with dynamos were designed so that they may readily be so equipped. The mail and express cars were so constructed that the 30-ft. mail compartment can readily be converted into a 40-ft. compartment, and for that purpose a blind door was built in each side of these cars.

All the cars are equipped with Northern Pacific special buffing devices, which have a capacity of 350,000 lb., and also with three-stem couplers having 8-in. tandem draft gear using one 8-in. plain and one 8-in. friction draft spring at each end of each car. The coaches, dining cars and combination mail and express cars are equipped with automatic deck ventilators with intake and exhaust working in conjunction. Eighteen of these ventilators are provided for each coach and seventeen for each dining car.

UNDERFRAME

The longitudinal sills are designed to resist the maximum shock due to buffing, which is assumed to be the equivalent of a static load of 400,000 lb. applied horizontally at the resultant lines of force acting at the center line of the buffing mechanism and at the center line of the draft gear, respectively. For this stress only the underframe members are considered, the superstructure being considered as supporting the underframe from buckling vertically.

The underframe is made up entirely of plates and structural steel shapes and is, in general, used on all types of cars included in this article. The center sill is of the fish-belly box-girder type with bottom cover plates only at the bolsters and cross-bearers. It is 2 ft. 4 in. deep at the center and 15 7/8 in. deep at the ends. The webs are 5/16-in. plates spaced 18 in. apart, being reinforced with 5-in. by 4-in. by 5/8-in. angles on the outside at the top and with 3 1/2-in. by 3 1/2-in. by 1/2-in. angles on both sides at the bottom.

The top cover plate for the stub-end cars is 1/2 in. by 30 in. and extends to within 2 ft. 1 1/4 in. of each end sill, while that for the vestibule cars is 3/8 in. thick and it extends a few inches beyond the end sill. On all of the cars the center sills terminate at the buffing plate. The body bolsters are of the double type, consisting of 5/16-in. pressed steel pans placed back to back, the side members being 5 ft. 10 in. apart. A cast-steel center plate is enclosed in the center sill girder and is designed to receive the Coleman locking device. The side bearings are

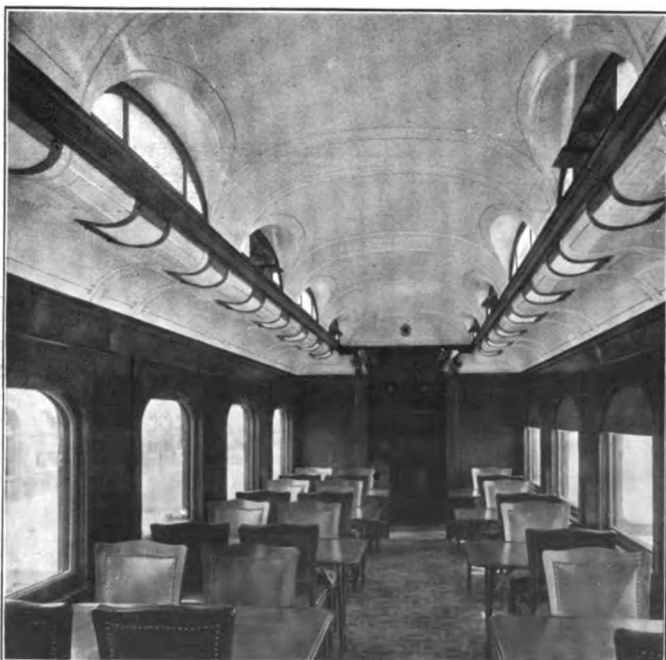

Interior of Northern Pacific Dining Cars

the coaches and the dining rooms of dining cars is of flexolith the color of which is natural gray in the dining cars and tinted

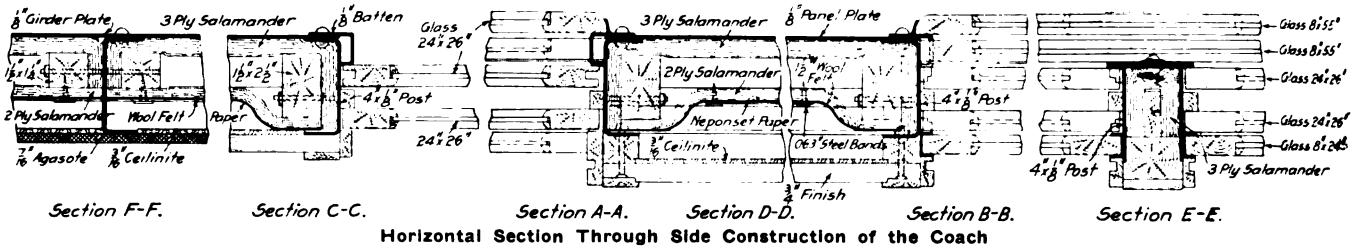

steel pans, extending between the center sill and side sills. The underframe is covered with 1/16-in. plates. The end sills are 1/4-in. pressed steel pans, 12 in. deep, extending between the side and center sills.

SIDE FRAMING

The general construction of the side framing in all types of cars discussed in this article is similar, the clere-story type of construction being used. The side posts are 1/8-in. pressed steel channel sections 4 in. wide placed with the backs at right angles with the side of the car. The side plates are 4-in., 8.2-lb. Z-bars. The upper and lower deck carlines and the deck posts are made of one piece of 1/8-in. steel plate pressed in the form of a channel. The deck sills are 3-in. by 3-in. by 3/16-in. angles. The outside belt rails are 4-in. by 1 3/8-in. by 7/16-in. dropper bars, and the inside belt rails are 3 1/2-in. by 1 1/2-in. by 3/16-in. pressed angles, both extending the full length of the car. The top of the outside belt rail is 2 ft. 11 1/16 in. above the bottom of the side sill.

In the vestibule ends four 6-in., 23.9-lb. I-beams form the door and vestibule diaphragm posts and four 4-in., 8.2-lb. Z-bars

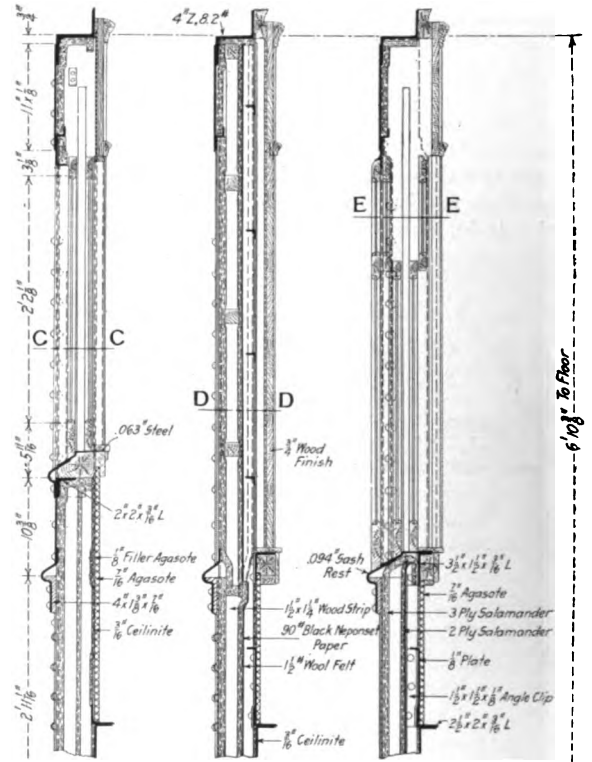
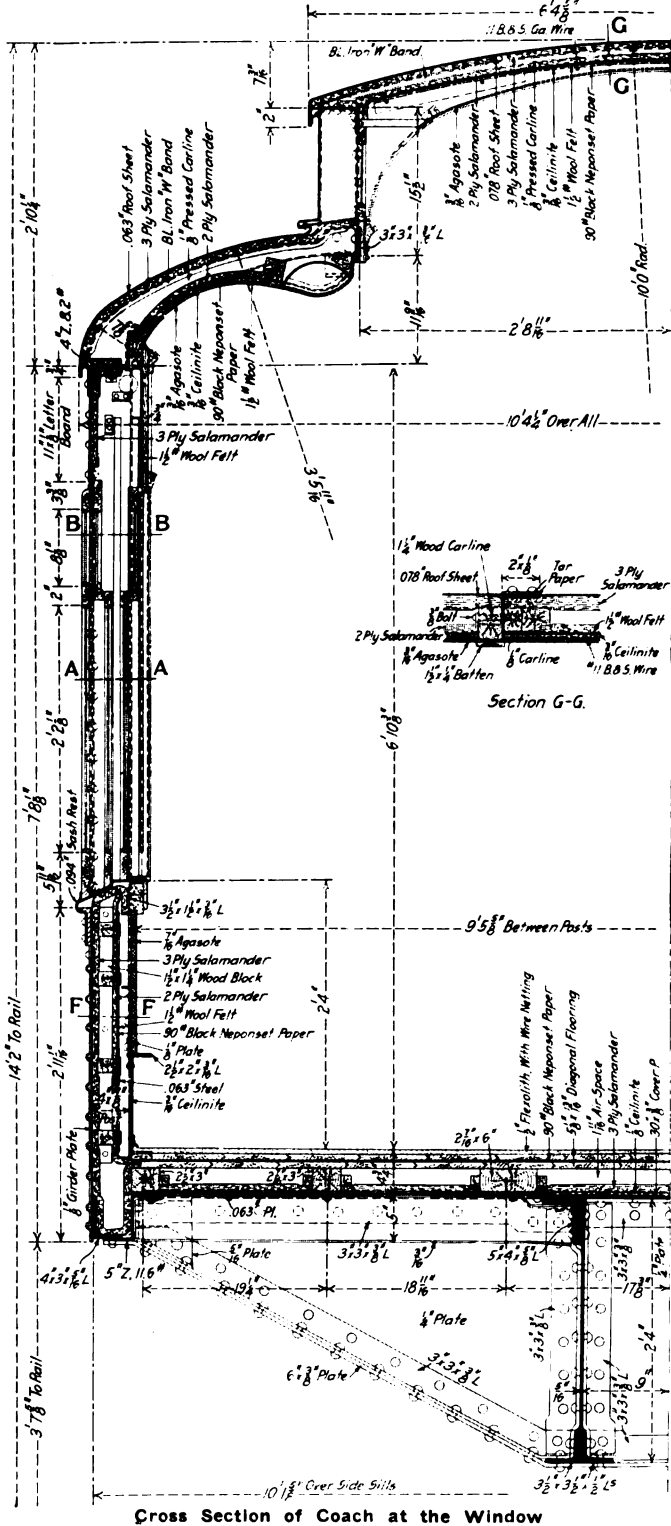

the intermediate and corner posts. The cast-steel buffer is mounted directly on the center sill and is further reinforced by a 7-in., 9.75-lb. channel 2 ft. 4 1/4-in. each side of the center line of the car. In the stub-end cars 12-in., 31.5-lb. I-beams are used for the door posts, and eight 4-in., 8.2-lb. Z-bars form the intermediate and corner posts, there being two corner posts at each corner. As in the vestibule end the buffer casting is attached directly to the center sill. An anti-telescoping plate extends across all sills back of the end sill.

INSULATION

The insulation for the floors of the coaches and diners consists of a layer of 1/8-in. ceillinite cemented to the steel sub-

floor and passing under the six floor stringers, a layer of 3-ply salamander, an air space, a course of Neponset paper laid between the two courses of 13/16-in. fir flooring and a layer of 1/2-in. flexolith with wire netting laid on the top course of wooden flooring. The insulation for the side and end walls consists of a layer of 3-ply salamander cemented to the inside of the steel sheathing, an air space, a course of 2-ply salamander, a layer of wool felt, a layer of Neponset paper, an air space and

steel annealed axles with 5-in. by 9-in. journals, 36-in. solid steel wheels and a distance of 7 ft. 7 3/4 in. from center to center of the Stucki roller side bearings. Cast-steel parts are used instead of forgings where practicable. Each wheel piece is made of one 9-in., 34.7-lb. channel reinforced at the top with a 3/8-in. steel plate. The end pieces are 5-in., 11.6-lb. Z-bars. The spring planks are 5/16-in. by 13 1/2-in. by 5-ft. 6 1/2-in. plates. The truck bolster is cast steel. The center plates of the car body and the

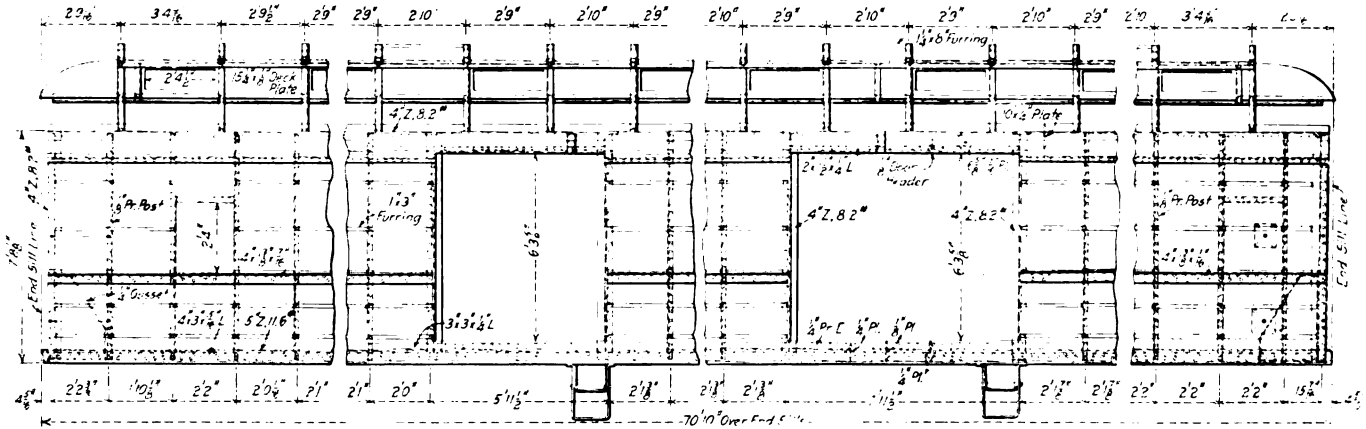

Side Frame of Northern Pacific Baggage Cars

a layer of 3/16-in. ceilitite cemented to the inside lining. The insulation for the roof, including both the upper and lower decks, consists of a layer of 3-ply salamander cemented to the roof sheets, an air space, 2-ply salamander, Neponset paper, wool felt and a layer of 3/16-in. ceilitite. These cars are equipped with Baker heaters and the Gold indirect steam heating system with sufficient radiating surface to heat the cars to 70 deg., with an outside temperature of 50 deg. below zero.

trucks are positively locked against any horizontal movement, and in addition the car body and truck are securely held together by the Coleman center plate locking device. The center plate faces provide 116 sq. in. actual or 101 sq. in. projected area of contact and were machined and ground together to a smooth working fit. The benefits of this, combined with the use of roller side bearings, are readily apparent. The braking of the truck is of special interest. One piece cast-steel brake hangers are used and they are longer than those usually used on 6-wheel trucks. Two brake beams are applied to the middle pair of wheels and one beam to the inside of each of the outside wheels. The design prevents the back surge of the truck when it comes to a stop, the brakes applying with a slightly preponderant downward force on the rear of the truck. The brake beams are



Interior of Coach Taken Under Its Own Illumination

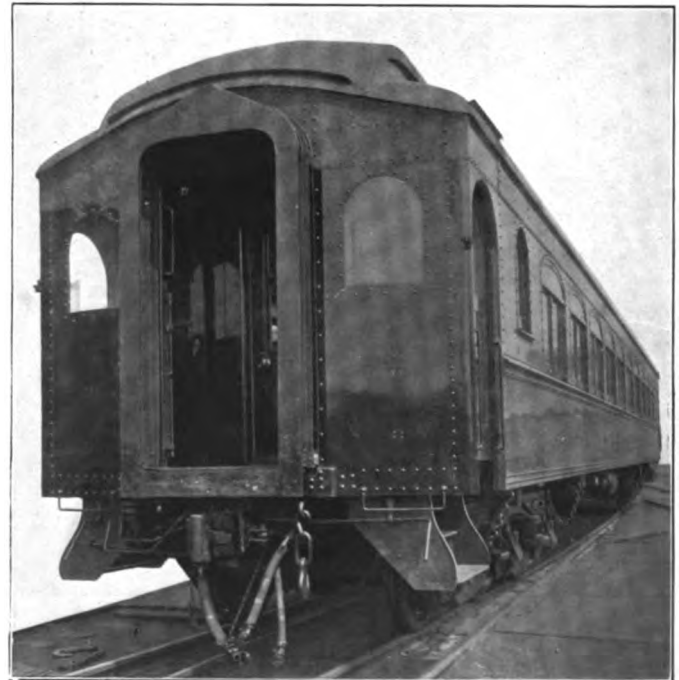

End View of Northern Pacific Steel Coach

designed to insure like pressures coming to both wheels on the same axle, maintaining the same relation of the brake head and shoe to the wheel, and provide an easy method for the removal

TRUCKS

Six-wheel trucks with structural steel frames are used under all the cars. They have a wheelbase of 11 ft., open-hearth

and reapplication of brake shoes. The braking power of the middle wheels is 32 per cent and for the end wheels 34 per cent.

LIGHTING

All cars are wired for the 64-volt, head-end electric lighting system, straight electric with candle-lamp auxiliary. The dining-

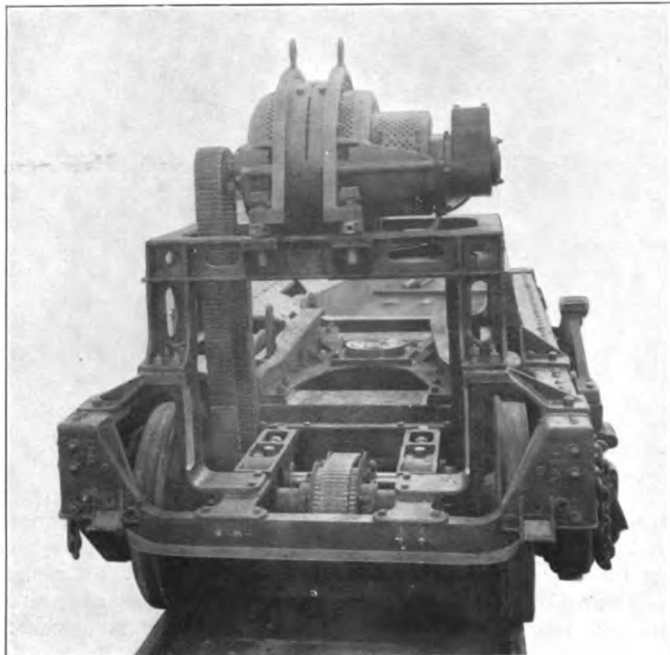

Axle Train Lighter Mounted on Truck

cars, dynamo cars and combination mail and express cars are equipped with 200-ampere-hour storage batteries. The electric wiring in all cars was installed in conduit. The dining-cars and coaches are equipped with a new system of car lighting which eliminates the projection of fixtures into the body of the

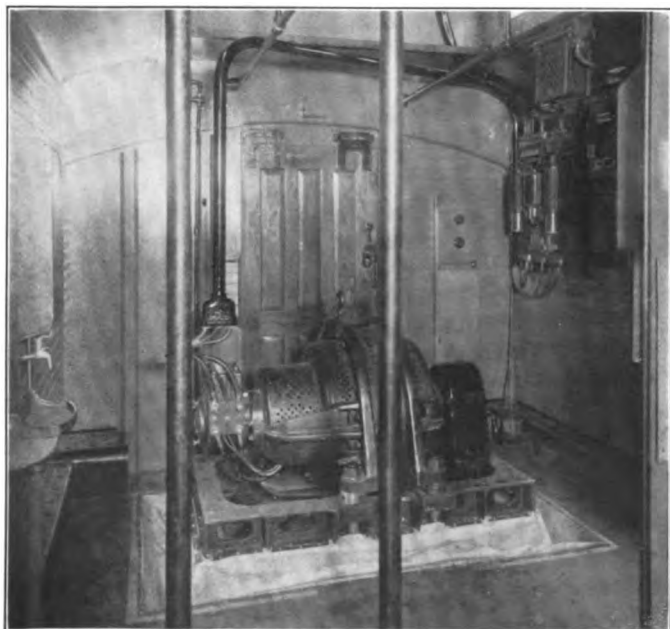

Axle Train Lighter In Northern Pacific Mail and Express Car

car. The new-style fixtures used were very carefully and accurately designed to give a large amount of light without glare. The illustration showing the interior of the coach was photographed at night with its own illumination.

Ten of the baggage cars and two of the mail and express cars are equipped with a 25-kw. steam turbine set with a switch-

board designed to allow charging of the batteries during the lighting hours. Two of the mail and express cars are equipped with 17½-kw. axle machine train lighters. These are mounted directly on the trucks and are driven through a jack shaft from the outside truck axle. Steel castings extending between the truck end piece and the transom, 13¾ in. each side of the center line of the truck and straddling the forward axle, support the jack shaft, and, together with the truck wheel pieces support the front foundation castings of the axle lighting machine. The back foundation castings are bolted directly to the truck transom, as indicated in the illustrations. The machine is driven by a Morse silent chain. A 45-tooth sprocket is mounted in the middle of the front axle. This drives a 31-tooth sprocket on the jack shaft and a 21-tooth sprocket on the jack shaft drives the 29-tooth sprocket on the machine. One of the photographs shows the machine inside the car. A heavy canvas webbing closes the opening in the car floor around the machine to keep dust and cold air out of the car. In service the machine and the opening in the floor are completely covered by a sheet iron casing.

An interesting feature in connection with the building of these cars is that the plans and specifications described the cars in such detail that builders were able to place orders for material as soon as they received the contract (December 4, 1914) and were thereby enabled to turn out the first cars February 20, 1915. These cars have been made up into new steel trains running between St. Paul and Duluth, between Spokane and Seattle and between Seattle and Portland. In addition to these, the Pullman-Northern Pacific Association has supplied 21 new steel standard sleepers for use in these trains.

CHIEF INTERCHANGE CAR INSPECTORS' AND CAR FOREMEN'S ASSOCIATION CONVENTION

The seventeenth annual convention of the Chief Interchange Car Inspectors' and Car Foremen's Association was held at Murphy's Hotel, Richmond, Va., September 14 to 16, 1915, F. H. Hanson, assistant master car builder, New York Central, presiding. The meeting was opened with an invocation by the Rev. J. J. Scherer, and the association was welcomed on behalf of the state of Virginia by Attorney-General John G. Pollard, representing Governor Stuart, and on behalf of the city of Richmond by Mayor George Ainslie. T. J. O'Donnell, arbitrator, Niagara Frontier Car Inspection Association, Buffalo, N. Y., responded for the association. President Hanson then delivered an address, calling attention to the greater uniformity of interpretation and improved enforcement of the rules of interchange resulting from the work of the association and laying stress on a number of conditions where further improvement is needed.

PRESIDENT HANSON'S ADDRESS

President Hanson spoke in part as follows:

The past year has been a very trying one for the managements of the railroads, compelling officers to spend much of their time studying new ways of economizing and reducing expenses without interfering with the quality of the service. Heavier power has been purchased with a view to handling a large number of cars per train and getting them over the road in as short a time as possible. This necessarily requires that all cars be in safe condition to be handled in such trains.

Some of the railroads are spending large sums of money equipping cars with steel underframes, friction draft gear, steel ends, etc., which materially assist in avoiding delays en route and keep the cars off the repair tracks. There are a large number of cars, however, that are not receiving these betterments and must be given careful inspection in order to know that they can be handled in such trains with safety; also to see that they are not cut out and sent to the repair or transfer track unnecessarily. Both of these considerations require

good, sound judgment on the part of the car inspector.

There is a general effort to reduce delays in the movement of cars. Delays are due to many causes, some of which will not be affected by any action we may take. Delays to cars in interchange and cars transferred, however, are matters over which we have some control. While a wonderful improvement has been made in the past year in reducing the number of cars transferred, there is still room for further improvement.

I note that the Arbitration Committee since Oct. 1, 1914, has prepared answers to about 150 questions, thus imposing a very heavy burden on this committee, as they cover 113 pages of the rules and 50 pages of interpretations. We should be more cautious in submitting trivial questions, thereby reducing the labor of the committee. With this end in view, would it not be advisable to appoint a special committee or make it a part of the duty of the executive committee to see that representatives of the M. C. B. Association arbitration committee, American Railway Association bureau of explosives and other similar organizations are invited and urged to attend our meetings?

The enforcement of the loading rules is now quite generally insisted on and has resulted in expediting the movement of traffic and decreasing claims for loss and damage to lading; yet the railroads in 1914 paid claims amounting to \$32,375,617, a material proportion of which might have been saved had the shipments been properly packed and secured. The education of the shipper to comply with loading rules is an important matter. It is not the intention of any railroad to impose hardships on the shippers or to antagonize them in any way. If representatives of the mechanical department make it a point to call on those who hesitate to comply with the rules and show them the danger involved when the rules are not complied with we will have very little trouble in securing compliance.

Another matter that should be given careful attention is defective brake beams and parts. A great many cars are now in service with parts worn to such an extent that they are absolutely unsafe. All roads should go into this matter very thoroughly by giving these parts special inspection as cars pass over repair tracks.

A few months ago a vigorous campaign was started by the railroad I am connected with. It was found that 95 per cent of our brake beam troubles were in the brake head, brake hanger and the brake shoes; the loop hanger brake heads were the worst. Several special men have been placed in all our large yards to make special examinations of trucks in every instance when this could be done, not only on repair tracks, but in yards as well. The result is that we have a miscellaneous assortment of brake heads, brake hangers, brake pins, etc., amounting to between 60 and 90 tons, removed at three important yards on the New York Central, Lines West.

H. Boutet, chief interchange car inspector, Cincinnati, Ohio, briefly sketched the development of the association and brought out the fact that a gain of 61 had been made in membership during the past year. Letters were received and read before the convention from D. R. McBain, superintendent motive power and rolling stock, New York Central, Lines West, who is president of the Master Car Builders' Association; J. J. Hennessey, master car builder, Chicago, Milwaukee & St. Paul; F. W. Brazier, superintendent rolling stock, New York Central, and James Coleman, superintendent car department, Grand Trunk, members of the arbitration committee of the Master Car Builders' Association and W. F. Schaff, superintendent, New York Central, Cleveland, Ohio. Mr. Hennessey called attention to the necessity for great care in making joint inspections, stating that cases had come to the attention of the arbitration committee where such inspection reports had been signed when the actual inspection had not been made by both inspectors.

MR. SCHAFF'S LETTER

In his letter Mr. Schaff said:

"I am particularly in sympathy with the work of your associa-

tion because my experience in the operating department has taught me the necessity of co-operating with your men in transportation work. It should be remembered that every man is an important integral part of the corporation by which he is employed, and his success depends upon his conscientious efforts to present inviting service to the public. Primarily, we are in this business to sell transportation, and upon its quality depends the amount of business we shall secure. Every man should feel himself a freight solicitor, whether he is making way bills, spiking rails, inspecting or building cars; his work should be done with the thought in mind that he is improving the quality of transportation we are inviting the public to accept. It is our duty and should be our purpose in doing our work to let no opportunity pass to invite the good will of those who want to use our service.

To this end we should familiarize ourselves not only with the work of our own department, but seek to intelligently conduct our own affairs so as to render assistance to those we work with. When business is once secured it is our obligation to perform the transportation as advertised, bearing in mind that net earnings are to be conserved. It is easier to conserve the net earnings if good equipment is furnished in the first place that will carry the load from originating points to destination with the least possible delay. Every time a car is cut out we tax the revenue. It is evidently true economy to spend money at the originating point rather than to make continuous expenditures en route.

"At interchange points an intelligent inspection is worth the price of a day and night engine crew. The inspector at the junction must determine when the cars are safe to run, and if not, where repairs should be made and whether transfer is necessary. In making these decisions he must consider the mileage the car has yet to make, the kind of road it is going over, the character of lading and the train service in which it will probably move. It has been my experience to see inspectors reject cars at interchange points with apparently no knowledge of the yard switching involved and no consideration of the movement of service. On the other hand, it has been my privilege to be associated with inspectors who took a vital interest in seeing that a proper inspection of the car was made at the point involving the least expense in switching and the least expense in moving to and from shop yards."

TRIFLING DEFECTS IN INTERCHANGE

The following paper on the problem of small defects in interchange was read by H. Boutet, chief interchange inspector, Cincinnati, Ohio: Interchange of cars, especially at large interchange points, is one of the serious problems of railroading and one which requires a great deal of thought, not on account of the serious defects that exist on cars, but because of the trifling ones, which would not be repaired if the cars were at its own shops.

Some of the inspectors imagine that the number of defect cards they get from the delivering line is what determines their value to their company. This is not the case at a few places, but all over the country. If a defect card is issued at one point the movements of the car are traced and the inspector who received the car on that line is asked to state why a card was not secured by him. Continually receiving such letters, the inspector makes up his mind that defect cards are what his company wants, and as he is desirous of holding his position, he falls in line and demands cards for all cars on technicalities.

Let us go home firmly resolved to work to the common sense view of the M. C. B. rules as interpreted by the arbitration committee. We should instruct our inspectors that we are not looking for every twenty-five-cent piece that we can compel the delivering line to be responsible for through a technicality, but have them look only for the serious defects—anything that will affect the safety of the handling of cars as to train movement, train men and the lading. If we will do this we will save a vast

amount of money each year that is now being wasted. While we are holding delivering lines for the small defects we are compelling them to do the same thing against our own line and compelling the inspectors to use more time in making the inspection. There is too much time lost in looking for and carding for trifling defects that do not affect the safety or usefulness of the car. This is a serious matter, especially in crowded terminals, where it is absolutely necessary that the cars be kept moving to prevent the terminals from becoming blocked. But the most serious part of it is that it causes the inspectors to overlook defect that should be seen and cars are not set out that are liable to cause trouble.

Count the cars that go through your terminals for a week and note the number carded for from two to thirty siding boards and side facia boards raked and broken or roof boards damaged; examine the defects and you will no doubt find that siding boards and facia boards raked through the paint are scratched by the nails in the door, that the roofing boards have the edges outside of the facia raked on house cars, and similar defects on coal and flat cars. Defects of this nature are causing more trouble in the interchange of cars to-day than anything else. There is not a member of this association who does not realize that it costs more to collect on many defect cards than the face of the card calls for. This is surely not making money for the companies we represent.

It will take an inspector five minutes at least to make out a defect card and tack it on a car. With from three to five cards to a cut of cars, they have been delayed fifteen to thirty minutes, and you cannot delay a switch engine and crew for less than 10 cents per minute.

I have not mentioned any of the other delays that may be caused in the yards by this individual delay; sometimes two other crews have been delayed, not only in your own yard, but in the other yard as well.

Discussion.—The importance of eliminating the practice of carding cars in interchange for small defects was recognized. The greatest difficulty in accomplishing this is found at the large interchange points, where, owing to the number of roads involved, it is more difficult to establish uniformity of practice than at points where two roads interchange. At the larger points improvement must come through the efforts of the chief interchange inspector. At Cincinnati unnecessary carding has been greatly reduced and uniformity of carding secured by means of a school for inspectors conducted by the chief joint inspector. This school is held once a month, and all inspectors are required to attend by their foremen. An evening session is held for the day inspectors and a morning session for the night inspectors.

SUGGESTED CHANGE OF ORGANIZATION

W. B. Elliot (Wiggins Ferry Company) read a paper in which he advocated a reorganization of the association on broader lines. He suggested that the association be made a central organization to include all local car and inspection associations as subsidiaries. Many subjects of general interest are considered at the meetings of the local associations and some of these could profitably be taken up by the larger organization at its annual meeting. The proposed plan would make the larger association a clearing house for all car department matters of interest to foremen and inspectors, and a selection of questions for general consideration could be made from those brought up during the year in the local associations.

DISCUSSION OF THE MASTER CAR BUILDERS' ASSOCIATION RULES OF INTERCHANGE

Rule 2.—The question arose as to the propriety of rejecting an overloaded car under paragraph *c*. In this connection it seemed to be the general opinion that the term "improperly loaded" does not apply to overloaded cars and that the rejection of such cars lies with the operating department and not with the mechanical department. Considerable discussion took place

as to the advisability of maintaining special agreements at variance with this rule and American Railway Association rule 15. This practice was defended on the grounds that under certain local conditions the rules cannot be successfully applied and that special agreements are therefore necessary. The association, however, adopted a resolution in favor of abolishing all special agreements modifying rule 2 and American Railway Association rule 15 after October 1, 1915.

At some points the use of the bad order return when empty card is used to allow cars to be sent forward to destination without transfer in order that cars not sufficiently defective to justify transferring the lading may be kept within the jurisdiction of the mechanical department and reloading at destination prevented. In some cases this practice is abused, however, and cars are allowed to proceed which are going long distances and ultimately have to be transferred before reaching their destination. According to the interpretation on page 7 in the 1915 revised rules, however, this card is intended for use when the load is destined to a point inside of the switching district, and a motion was made and carried that this interpretation be accepted by the association.

Rule 3.—The members were in doubt as to the application of paragraph *f*, requiring the application of brine tanks after October 1, 1916, to refrigerator cars in which salt is used with the ice. The opinion was expressed that the application of this rule depends entirely upon the product with which the car is loaded and that enforcement of the rule against cars loaded with products not requiring the use of salt with the ice would not be justified. As this section of the rule does not go into effect until next year it was referred to the executive committee with instructions to provide the information necessary to define the application of the rule.

Rule 21.—A question was raised as to whether this rule applied to rack cars with open tops used in handling coke. The opinion was that such cars do not come within the meaning of this rule. Where they were not originally equipped with running boards this rule does not justify the application of running boards at owners' expense.

Rule 42.—The change in the footnote under this rule left many of the members in doubt as to whether owners could be held responsible in case of three or more broken end posts where some of the posts are decayed. The footnote in the revised rules clearly applies to such combinations in the case of longitudinal sills only, but many of the members follow the practice of billing the owners for such defects where the decayed condition of the posts is sufficient to have been responsible for the failure of the car end. It was the belief that where the joint evidence plainly indicated the existence of such conditions car owners would accept the responsibility. However, since the wording of the footnote is plainly applicable to sills only and therefore refers to rule 41 rather than to rule 42, the association went on record favoring the placing of the footnote under rule 41 and its application to that rule only.

Rule 43.—Doubt was expressed as to the responsibility of the owner for damages to the superstructure of a steel underframe or all-steel car due to the failure of the underframe for which the owner is responsible in accordance with this rule. It is general practice to handle such cases as owners' responsibility accompanying the bill with joint evidence. Rule 48 was considered as applying in such cases.

Rules 58 and 59.—In the discussion the question came up as to the interpretation of these rules in case an air hose is torn off. Under rule 58 missing air hose is delivering line responsibility, while under rule 59 torn air hose is owners' responsibility, and there was some difference of opinion whether a hose torn off at the nipple on a car offered in interchange would be considered as a missing or a torn hose. At certain points a hose torn off is considered as owners' responsibility on the grounds that no one knows anything about how the hose was torn off and therefore cannot state whether due to unfair usage or to

the worn condition of the hose. The missing coupling lost with the hose is charged to the delivering line, since it has the coupling in its possession. Another interpretation was that the road having the car in its possession has a right to charge the owner for a hose torn off, but when delivered to a connecting line the delivering line should be held responsible. On motion this interpretation was approved by the association.

Rule 120.—The question was raised as to whether the labor cost of repairs was not to exceed 10 per cent of the base price given in rule 116, or whether depreciation was first to be deducted from the base price. The base price is used, no depreciation being allowed.

In the case of four or more longitudinal sills requiring renewal or splicing the car would be handled in accordance with the footnote under rule 42 unless the labor cost of making the repairs exceeds 10 per cent of the cost price of the car body, in which case it would come under this rule.

OTHER BUSINESS

The president announced that the executive committee was considering plans for increasing the scope of the work done by the association in order to more generally cover the car department field. It has been decided to offer prizes for the best papers on "Apprenticeship in the Car Department," the papers to be presented before the association at its next convention, and a committee will be appointed to conduct the competition. For the best paper a prize of \$25 will be offered; the second prize will be \$15, and the third \$10.

The report of the secretary-treasurer showed that the membership of the association is now 382. The treasury has a balance on hand of \$184.85.

The following officers were elected for the ensuing year: President, A. Kipp, general car inspector, New York, Ontario & Western; vice-president, W. J. Stoll, chief interchange inspector, Toledo, Ohio; secretary-treasurer, W. R. McMunn, general car inspector, New York Central. The following were elected members of the executive committee: Z. B. Wilson, Southern Railway; C. W. Mattox, Chesapeake & Ohio; A. Armstrong, chief interchange inspector, Atlanta, Ga.; C. J. Stroke, New York Central, and W. M. Halbert, chief interchange inspector, East St. Louis, Ill.

STEEL CAR DESIGN FROM A PROTECTION STANDPOINT*

BY JOHN D. WRIGHT

General Foreman Painter, Baltimore & Ohio, Baltimore, Md.

In the construction and design of steel passenger equipment cars, so many features are of more importance than the painting that it is not surprising if it receives little consideration on the part of the designer. Both the design and construction, however, have a direct influence on the paint coatings which are applied to protect the metal, and they, in turn, determine, in a large measure, the life of the vehicle. If no protective coatings of any kind were applied to a steel passenger car it would, in a few years, be almost a total loss from corrosion. Steel passenger equipment cars have now been in service long enough to develop their weak points, and show the parts susceptible of improvement, and, so far as the relation of the design and construction to the preservation of the metal is concerned, our observations have brought us to the conclusion that steel roofs, decks, deck screens, sash and doors are the principal parts to be considered in a paper on this subject. We might add that some modifications have already been made in these features.

Experience has taught us that a canvas roof, if properly applied and painted at the outset, is more easily preserved than the all-steel roof, and it can remain longer in service without

being repainted. If, for any reason, the regular shopping period of the cars is prolonged, canvas roofs may be neglected without serious consequences, but this is not the case with the steel roofs, for they must receive attention at regular intervals, and be repainted at the terminal yards if the cars cannot be sent to the shops, in order to keep them from rusting. A number of all-steel car roofs have been constructed with raised expansion joints, the vertical surfaces of the joints being about $1\frac{1}{4}$ in. in height. The abrasive action of the cinders soon wears off the protective coatings from these joints, exposing the metal. Though steel cars have only been in service a few years, the writer has already seen roofs on which the vertical joint strips were worn and eaten almost entirely away by the action of the cinders and corrosion. Trouble of this kind may be overcome somewhat by frequent painting and sanding, but this will not protect the joints indefinitely. And it is not always convenient to paint them, especially on the cars operating on branch lines, or running in and out of foreign terminals. For these reasons we feel that steel roofs with joints projecting as little as possible above the main surface of the roof sheets are much better adapted to the protection afforded by paint coatings.

In the construction of steel passenger equipment cars it was quite natural to adopt many of the features of the prevailing wooden cars, so a number of steel cars have been built with hinged deck sash and screens for ventilation. Others are constructed with stationary deck sash and ventilators, and quite a number with the arched roof and ventilators, omitting the decks and deck sash entirely. On the wooden cars, the deck screens and hinged deck sash for ventilation appeared to work out satisfactorily, as a majority of the wooden cars were so equipped. But on the steel cars, the deck screens are objectionable because they form pockets in which the gases from the tunnels, and the cinders and moisture collect, to destroy the paint coatings and in this manner start corrosion. They are furthermore objectionable because the corrosion taking place back of the screens cannot be detected without going to the trouble of removing the screen frames. The employees at the terminals may notice rusting on the parts easily seen and repaint the roofs and the outside parts of the screen frames, but the hidden parts, which are not so accessible, are apt to be neglected until the cars are sent to the shops for classified repairs. And considerable damage may be done before the cars are returned to the shops.

Considering the improved methods of ventilation in use during recent years it would appear desirable to construct steel cars without deck screens and use the ventilators in place of the deck sash for ventilation. This would make them better adapted to the protection offered by protective coatings and also decrease the expense connected with the breakage of deck glass. Better still, from this point of view, is the arched roof with ventilators, as it does away with the deck sash entirely, and the corners, pockets and projecting surfaces common with the deck or clere-story construction.

There does not seem to be much trouble in properly protecting the exterior bodies of steel cars with the methods of painting already in use, but for both the exterior and interior finish, the use of smooth, level steel sheets is strongly urged in order to reduce the number of coats of surfacer, and the amount of glazing and putty of various kinds, to say nothing of the sandpapering and rubbing necessary to secure a good, finished surface. Rough sheets require too much paint material to make a level surface, and the heavy coating applied tends to reduce the life of the paint body. Furthermore, the protection afforded is gaged by the thinnest part of the film, where the surfacer may be rubbed or sandpapered almost entirely away, and not by the thick coating hanging in the rough parts of the steel.

The writer has seen a number of steel sash that have failed completely in a few years and from this, in connection with the fact that the other parts of the cars were in good condition, it would appear that steel sash cannot well be protected

* Presented at the forty-sixth annual convention of the Master Car and Locomotive Painters' Association.

by the use of paint coatings. Brass or copper sash, which need no protective coatings, may prove economical and practical, and may eventually take the place of both wood and steel sash in the steel cars, but from the fact that the ordinary steel sash are hard to protect from corrosion, they do not seem to be an improvement over the wood sash for use in steel equipment. Certain types of steel doors have rusted out entirely after a few years' service, though other types seem to be giving satisfaction. Modifications in the design of the doors that fail from corrosion will have to be made to assist the paint coatings in the protection of the metal. The change from wood to steel passenger equipment cars has been so rapid that it would not be surprising if experience eventually proves that a number of parts which gave satisfactory service on the wooden cars will be better adapted to meet the demands of steel equipment if they are changed somewhat in design and construction.

PIECE WORK FOR THE PAINT SHOP*

BY H. HEFFELFINGER

Foreman Car Painter, Pennsylvania, West Philadelphia, Pa.

The most equitable method to follow in fixing piece work rates for the application of any coat of paint or varnish, or such operations as puttying, knifing, filling, sandpapering, rubbing and striping to be done either to the interior or exterior of passenger equipment cars is by measurement. The measurement should be on what the foreman painter feels sure is a fair price to pay for each separate operation including striping, when done in bulk, for example, all over the body outside of an open end, of the smallest passenger car handled. The deck, roof, platforms, hand rails, underframe, tanks, trucks, etc., should be rated separately. Good judgment gained by personal experience and the maximum time it takes to do any separate operation, including time to get material, place scaffolding, etc., when paid for by the hour rate, should be the basis to set rates fair to the company and employees. Consideration should be given both to the fast and slow workmen, since both can do good work. The workmen should not be limited as to their daily earnings but allowed to make all they can, providing their work passes inspection.

Assuming that prices have been fully agreed upon for the smallest passenger, baggage or express car, measurement should then be taken, which is easily done by getting the square feet in the sides and ends of the car, deducting the area of the window and door openings. The price per square foot can then be calculated from the price fixed for each separate operation when done in bulk. This price can be used for all sizes of cars.

The price per foot for either size, gold or color lines, should be based on the price set for running these lines over the entire body. The letters and numerals of railroads are generally of a standard size and style, which permits the outlines being pounced on and the work done by the pencil hands who do the striping. From the price set for each letter or numeral can be figured the price per car. From this basis larger or smaller letters or numerals can be rated when laid out by pattern. Having the rate per square foot for each operation, excepting lettering and numbering, the price to be paid for either the upper or lower half of one side, the fascia board, letter board, panels between windows, belt rails, corner posts, etc., can be easily determined. The same practice of measurement can be carried out on the inside of the car, not including the headlining and floor, which should be measured separately. There should be a fixed rate for the application of each coat of paint, varnish or whatever operation is required, say to finish one sash, blind, curtain runner or seat frame. The rate for each

operation to be based on the time it takes to do each piece or a full set. Before setting piece work rates a shop should be well organized with established day or hour rates, which should govern the piece work rates according to the class of work performed, whether it be by a pencil hand, brush hand, rubber or laborer.

Printed Forms.—Printed forms should be issued, one to check up the piece work accounts, showing on the front the serial number of the card, to whom issued, date of issuance, date work completed, the number of operators, the charge number, the number of pieces, the number of operations, piece work prices and the total amount. It also should be noted whether or not the work is inspected and by whom. The back of this card should show the names of the workmen, the number of the workmen, the time on and off, the number of hours, the total hours day work, with rate per hour, the amount and the word "correct" with space for the signature of the foreman. A card of this description should be used mostly for giving out work in bulk.

A second card should be printed showing the serial number, the charge, the date the work was issued and completed, the time on and off, the names and numbers of the workmen, the hours, the total hours, the hourly rate and amount, with the word "correct" and a space provided for the signature of the workman. On the back of this card there should be left a place for the name of the gang leader, the total number of pieces, the rate and the amount, together with a space for the numbers of the cars worked on, also a space for the kind of operation, with the prices.

A chart should be printed showing the price for each individual operation, such as doors, inside and outside, seat frame, etc. Another chart should be made of the same description with spaces left blank to write in the operations that have been authorized but have not been printed.

When all the work has been completed it should be inspected and checked from the card by the persons issuing the card, if possible, and frequently by the foreman and assistant foreman. After the work is completed and the cards have been approved by the foreman, they are turned over to the piece work clerk, who separates all the charges and pro-rates the money by the time made and enters it in a book provided with a column for each person's account.

COKE REPLACING COAL IN SWEDEN.—Sweden's importation of German coke is reported as exceptional recently. It is caused by the high prices of coal in England and the freights. Many Swedish steamers as well as state and private railroads are now using coke, either alone or mixed with coal or wood, with apparently good results as coke imports are continually increasing.—*Iron Age.*

NOISE AND ACCIDENTS.—Fatigue has a notable influence in causing accidents, and anything that will tend to reduce or increase fatigue among workers should therefore receive consideration. Noise, for example, should have a prominent place in the list of items accredited with the production of fatigue. Loud noises, even though produced for only a short time, irritate the average person; and if they are continued all day, and every day, they may have a serious effect on the nervous system, and become a potent factor in causing fatigue. The older employees in a noisy shop become more or less accustomed to the noise, and often can readily detect any new or unusual sound. New men are likely to be confused by the constant loud noise and the strangeness of their environment, and are less likely to note warning sounds. When the din in a shop is so great that a workman must shout into his companion's ears in order to be heard, it must needs be a sound very much out of the ordinary to draw his attention to danger and keep him out of harm's way.—*Travelers' Standard.*

*Abstract of paper presented at the forty-sixth annual convention of the Master Car and Locomotive Painters' Association.

SHOP PRACTICE

REPAIRING DRIVING BOXES

BY P. F. SMITH

Mechanical Engineer, Chicago, St. Paul, Minneapolis & Omaha,
St. Paul, Minn.

Owing to the constant delays which were being experienced in getting out driving box work at the St. Paul shops of the Chicago, St. Paul, Minneapolis & Omaha, it was decided some time ago to make some radical changes in the method of handling this branch of locomotive repairs. Accordingly, all the tools and accessories used were regrouped in one end of the machine shop so that all operations may be performed with a minimum amount of handling.

The equipment used is shown in the following list:

- 60-in. Niles-Bement-Pond motor reversing planer.
- 32-in. Motor shaper, motor driven.
- 42-in. Bullard vertical turret lathe, motor driven.
- 42-in. Barnes drill, motor driven.
- Hydraulic press for forcing in and out driving box brasses.
- Hand-operated screw press for closing driving box brasses.
- Babbitt furnace for melting babbitt.
- Babbitt table consisting of a cast-iron face plate.
- Three jib cranes.

By referring to the layout of the group it will be seen that the babbitt furnace and table are served by one of the jib cranes,

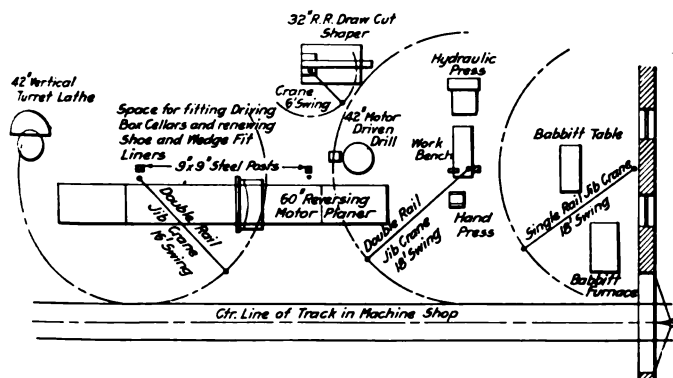

Layout of the Driving-Box Group

having a swing of 18 ft. Another 18-ft. crane serves the presses, the work bench, the drill and the planer, while a 16-ft. crane serves the planer and the turret lathe. The shaper has its own crane, which has a swing of 6 ft.

Part of the boxes repaired are of a standard design of cast steel, with removable brass liners on the shoe and wedge faces and inset hub faces of babbitt metal. A drawing of one of these boxes is shown. It is the front and back box for a 21 in. by 26 in. 10-wheel engine, and with the exception of a few minor details differs from the main driving box only in the diameter of the journal and brass fit in the box. In the main driving box these dimensions are one-half in. larger. The lubricant used is grease and the brasses are of Ajax plastic bronze. The grooves for feeding the grease in the bearing faces of the brass and the shoe and wedge liners are cored to save chipping when fitting the boxes to the axles. The liners are fastened by four $\frac{5}{8}$ in. copper rivets and a $\frac{3}{4}$ in. copper threaded plug, in addition to top and bottom lips. They are finished for a standard distance from face to face of $13\frac{1}{2}$ in., but when new liners are applied this is increased to $13\frac{3}{8}$ in., which permits of two shoppings before they are scrapped. The hub face of the box has a double dovetailed groove which securely holds the babbitt hub liner, and the brass is held through the crown by two $\frac{3}{4}$ in. taper brass plugs which are driven in tight.

In order that the method of procedure may be made clear a

set of boxes for a 10-wheel engine, similar to those shown in the drawing, will be followed through the shop from the time they come out of the lye vat until they are ready to be put back under the locomotive.

The boxes are moved from the lye vat to the machine shop on a push car. They are then examined to determine the extent

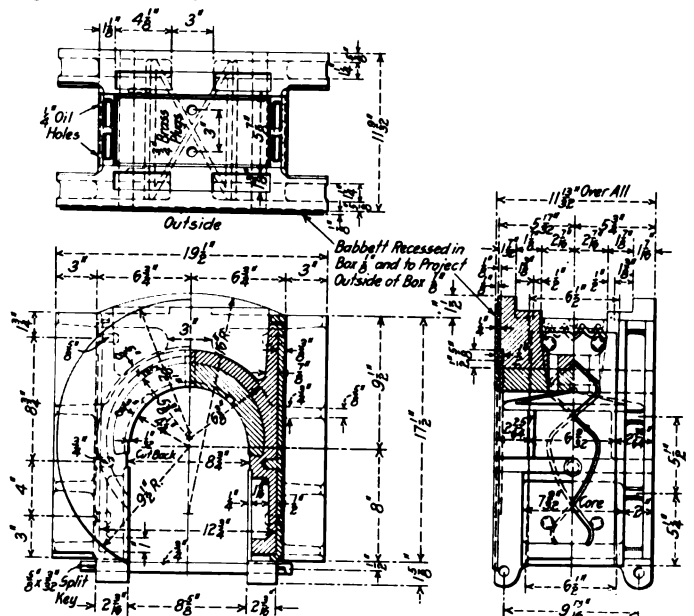

Type of Cast-Steel Driving Box Handled

of repairs necessary. If there is sufficient metal in the crown of brass they are marked for closing. If any are worn to the condemning limit in crown they are marked for new brasses, after which all the brasses are removed in the hydraulic press. New brasses are never applied unless the old ones are worn to the limit, because of the high first cost of the Ajax metal.

In this case let us assume that the front and back brasses may be closed, but that the main boxes will require new brasses. After the old brasses are removed the boxes are taken from the



Babbitt Furnace, Showing Driving Box in Place for Removal of Hub Liner

hydraulic press to the babbitt furnace, where they are submerged hub face down in the hot babbitt contained in one of the melting pans. These pans are of cast iron and in one of them are a number of thin projections extending from the sides and corners

toward the center to serve as a support for the box. The old babbitt is thus removed and the box at the same time heated ready for rebabbling. The boxes are next transferred to the babbitt table, where the new babbitt is applied, using metal formers. The handling of the boxes from the push car to the hydraulic press and from the press to the furnace and babbitt

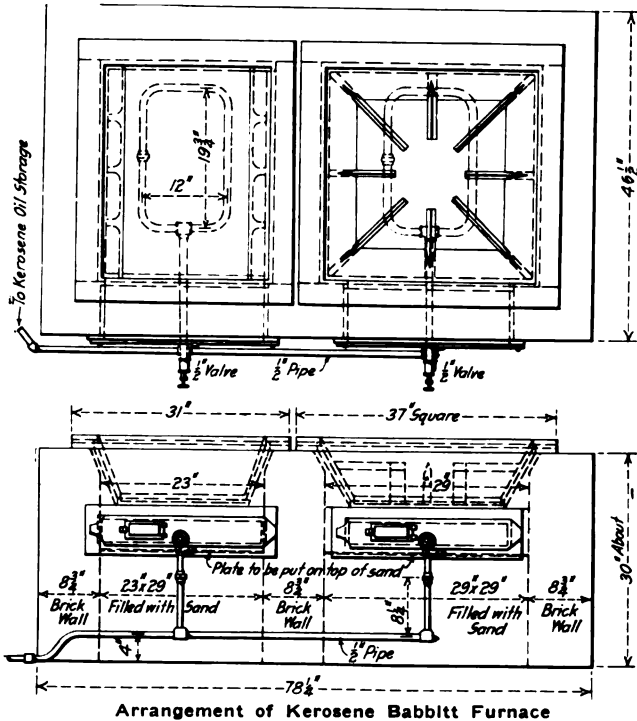

table is accomplished with two jib cranes, which are equipped with air cylinder hoists.

The boxes are now ready to receive the brasses and the time required to complete the operations so far performed is as follows:

- Removing old brasses at hydraulic press, one man only, six boxes, at four minutes each..... 24 min.
- Handling boxes from hydraulic press to babbitt furnace, removing old babbitt, rebabbling and returning to hydraulic press ready to receive brasses, one man only, six boxes at 15 minutes each 1 hr. 30 min.



The Type of Hand Press Used for Closing Crown Brasses

The new brasses for the two main boxes are selected by the shaper man from a stock of the various patterns kept on the floor adjacent to the shaper. These are finished to fit, the proper sizes being taken from the boxes at the hydraulic press. The press man then puts them into the boxes at a pressure of 35 to 40 tons.

The press man takes the four old brasses for the front and back boxes to the hand press and closes them in. This drops the crown and changes the angle at the bottom of the brass where it fits into the box. In order to get this fit correct he now chips down about one inch on the brass and makes a driving fit into the box, using mild steel shims of the proper thickness to fill above the crown. When a fit is obtained the brass is removed and finished on the shaper, using as a guide the part just finished by hand. After the brasses are reshaped the liners are applied and they are pressed into the boxes.

After the main boxes have been drilled and reamed to receive the crown plugs the boxes are ready to receive the cellars. While having the crown brasses reapplied they have been handled entirely by the jib cranes, and the following time has been consumed:

- Shaping new brasses for main boxes, pressing them in and drilling for the crown plugs; 2 brasses at 40 mins. each... 1 hr. 20 min.
- Closing old brasses, making and drilling liners, fitting and shaping old brasses and pressing in ready for cellars; 4 brasses, at 40 mins. each..... 2 hr. 40 min.

The six boxes are now transferred to the floor back of planer, where the cellars and driving box saddles are fitted and the shoe and wedge liners examined. In closing brasses it sometimes spreads the box a trifle at the cellar fit and when cellars are found loose they are babbitted on the sides to make a snug fit with the box. The shoe and wedge liners, if loose, are tight-

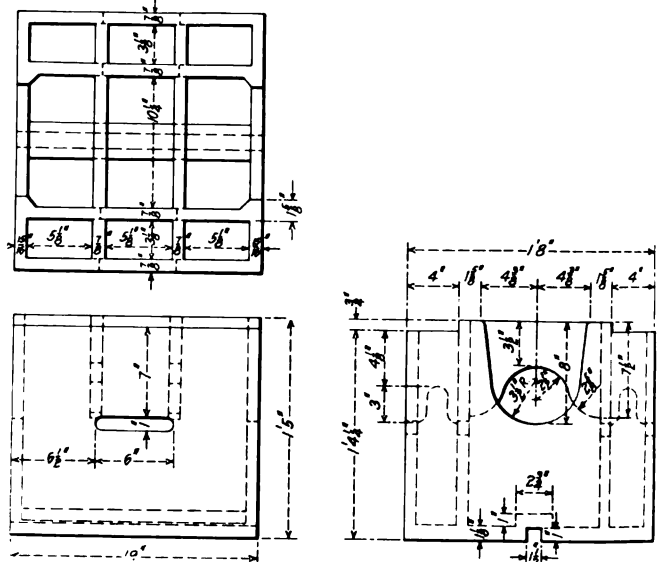

Face Plate Used on Planer for Finishing Driving-Box Shoe and Wedge Faces

ened, if worn to the limit they are scrapped and new ones applied. Assuming that on the set of boxes under consideration it was found necessary to tighten the liners and babbitt the cellars, the time required is as follows:

- Babbitting and refitting in boxes, six cellars, at 10 min. each. 1 hr. 0 min.
- Tightening liners and fitting driving box saddles, six boxes at 17 1/2 min. each 1 hr. 45 min.

The boxes are next transferred to the 60-in. planer, where the liners on the shoe and wedge faces are planed. The planer is arranged so that twelve boxes can be planed at once, six lined up on either side of a box face plate, thus utilizing both planer heads. A detail of the face plate is shown in one of the drawings. This method assures perfectly parallel surfaces.

When the liners have been finished the boxes are transferred to the Bullard vertical turret lathe, where the hub face is finished and the brasses bored to fit the journals. The two operations can be accomplished at one time, but this practice is

not followed, as it would result in mixing the brass and babbitt chips. Both operations are performed, however, with the one chucking. The boxes are handled while at the planer and verti-

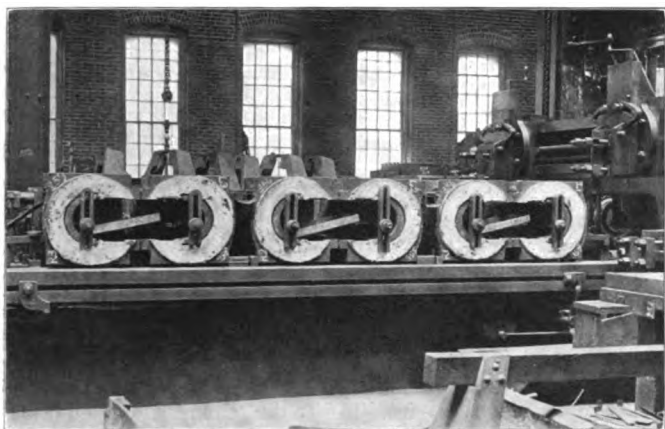

Driving Boxes Set Up on Planer for Finishing Shoe and Wedge Faces

cal turret lathe by a jib crane with air hoist trolley. The time required for the different operations is as follows:

Boring brasses to fit axles, including one roughing and one finishing cut, and relieving brass front and back 1/32 in., six boxes at 15 min. each.....	1 hr. 30 min.
Facing babbitt hub, six boxes, at 5 min. each.....	30 min.
Planing shoe and wedge faces, 1 roughing and 1 finishing cut, six boxes at a time.....	4 hr. 30 min.

The total labor time required to handle the entire set of boxes from the lye vat through the shop until they are ready to go on the axles, it will be seen, is 15 hr. 9 min. In every case the operations are performed by one man, the handling being done by the jib cranes.

A POSSIBLE SUBSTITUTE FOR ACETYLENE IN WELDING AND CUTTING

BY J. F. SPRINGER*

Gas welding and gas cutting have very fully proved their practical value, and to-day the question to be considered is not so much whether or not certain lines of work may be done with gas, but whether there may not be some way to cheapen the process. Oxygen is, and has been, the chief expense; it is advisable to have it pure, especially for cutting. Its price has been reduced during the past few years, but at present there would appear to be nothing in sight warranting us in expecting any further reductions of a radical character. The cost of acetylene depends upon the price of calcium carbide, and as one pound of carbide produces 4 or 4½ cu. ft. of acetylene and no more, there is not much prospect of reducing the acetylene cost below 1 cent per cu. ft.

Hydrogen is at the present time the chief competitor of acetylene. Where the installation of welding and cutting equipment is sufficiently large to warrant the use of an electro-generator to produce oxygen by the decomposition of water, hydrogen is generated as a by-product. Although produced in exactly the right proportion, theoretically, for union with oxygen, an excess of hydrogen must be provided, however, for practical use with the torch. The greatest usefulness of hydrogen is probably in cutting operations, especially on steel. If the cutting is a preliminary to machine tool operations acetylene is apt to carbonize a thin skin on the edge of the work and so harden the surface, while hydrogen has no such effect. For general use, however, especially in welding, the low thermal value of hydrogen as compared with acetylene, is very much in favor of the latter. The thermal value of acetylene is about 1555 B. t. u. per cu. ft., which is nearly five times as much as hydrogen.

There is, however, a liquid gas product of certain kinds of natural gas which seems to promise a marked reduction in the cost of fuel gas for use in autogenous welding and cutting, especially for certain lines of work. The new gas seems to have originated through the development of the manufacture of natural-gas gasolene. This industry is now about 11 years old, dating from 1904, when gasolene was obtained in commercial quantities by simply collecting the liquid formed by condensation in pipes transmitting natural gas. The next step was the artificial chilling of the pipes, followed by low pressure, single stage compression. Two or three years ago the practice of carrying the raw gas through two stages of compression was introduced, the products being separated into two forms of gasolene. The product derived from the first stage is substantially the gasolene of commerce. The product of the second stage is a light, high-grade gasolene which is useful for blending with heavy naphthas, the final product being sold for automobile use.

The semi-liquid product which may be used in welding and cutting, is the yield of a higher-stage compression, and is so volatile that it should by all means be regarded and handled as a gas. A beginning has already been made in its manufacture. At Sistersville, W. Va., and Kane, Pa., are found natural gases which lend themselves to high compression and produce a semi-liquid of high thermal value. This product has already received a limited application in welding and cutting. In its semi-liquid condition, one pound produces, upon vaporization, 10 cu. ft. of gas. It is shipped in metal containers and it is considered possible to so proportion the container that 100 lb. of metal will hold 100 lb. or more of the fuel.

In the following table are given the various hydro-carbon gases to be found in natural gas, together with their heating value per cu. ft.:

Methane (CH ₄)	1065 B. t. u.
Ethane (C ₂ H ₆)	1861 B. t. u.
Propane (C ₃ H ₈)	2654 B. t. u.
Butane (C ₄ H ₁₀)	3447 B. t. u.
Pentane (C ₅ H ₁₂)	4250 B. t. u.
Hexane (C ₆ H ₁₄)	5012 B. t. u.

The ordinary natural gas consists largely of methane, the heating value of which is low in comparison with acetylene. At Follansbee, W. Va., a natural gas is produced which contains no methane and is made up of approximately four-fifths propane and one-fifth ethane. This gas has a thermal value of 2,468 B. t. u. Experiments with this gas at various stages of compression indicate that the constituents of higher thermal value are first liquefied leaving the others in the residual gas. When subjected to 400 lb. pressure per sq. in. at 32 deg. F., and revaporized a gas of varying quality was obtained. Of several samples taken at regular intervals, one was almost pure ethane, another almost pure propane. The lowest thermal value was 1,808 B. t. u., and the highest 2,621 B. t. u. The methane, which has the lowest heating value and is therefore least desirable in the semi-liquid product, requires a pressure of 2,700 lb. per sq. in. to cause it to liquefy, and is therefore not apt to be present in the product of compression under 400 lb. per sq. in.

From another set of experiments with Follansbee gas under 400 lb. pressure, it was found that samples drawn from the top of the same cylinder varied considerably in quality and heating value. This would indicate the necessity of constantly changing the regulation of the torch, which would be impracticable. However, it has been found that by drawing the supply for the torch from the bottom of the cylinder a gas of approximately uniform quality may be obtained.

It was previously stated that the semi-liquid product could be stored in containers holding an amount equal to their own weight. It is worth considering what this means in relation to its portability. The users of acetylene either manufacture their own gas in a stationary generator plant and pipe it to the points of use, or else use metal containers which hold a small weight of gas relative to the weight of the container itself. This advantage of the semi-liquid natural product is not only of value about

* Address 618 West 136th Street, New York.

the shop but reduces the transportation charges. Each pound of semi-liquid occupies a space of 49 cu. in., and on expansion will produce 10 cu. ft. of gas the heating value of which is from 30 per cent to 75 per cent greater than that of an equal volume of acetylene.

The boiling point of the Follansbee product is—40 deg. F., and at 32 deg. F. it requires a pressure of 400 lb. to maintain it in the liquid state. At 131 deg. the pressure is 755 lb., which is well within the present practice in handling similar products. If higher temperatures are apt to be met it will not be difficult to secure containers to withstand the higher pressures.

The new product has not as yet been applied extensively as a substitute for acetylene in welding and cutting operations, but a practical beginning has been made. It has found considerable use in shops in the Pittsburgh district, and there has been some application in Brooklyn. A special burner is needed, for the reason that the oxygen supply necessary is relatively larger than for acetylene. Accordingly, the gas inlets must provide for the correct practical ratio of the two gases. In burners using acetylene, the ratio between acetylene and oxygen varies with the type of construction and operation and similar results may be expected with the new gas. However, it is not likely that any revolutionary changes in design will be found necessary. What does appear to be advisable is some means of reducing the high temperatures, as such temperatures tend to increase the difficulty with which certain lines of welding may be done. The practical use of the gas in cutting seems to mark it as especially suitable for this purpose; those who use hydrogen in preference to acetylene to avoid carbonization will not favor it.

Let us now consider the probable cost of the new product. The manufacture of natural-gas gasolene is now quite extensive. In the ordinary conduct of this industry a very considerable quantity of gaseous material goes to waste. This material contains some of the higher hydro-carbons of high thermal value which are subject to liquefaction or semi-liquefaction at moderately high pressures. The semi-liquid gas may therefore be compressed as a by-product of the natural-gas gasolene industry. The cost will not be influenced so much by the value of the gas as by the expense of carrying it through the higher stages of compression, and there is reason to believe that this expense will be about one-half cent per lb. Double this amount would be a fair price to the manufacturer. This price is just about one-tenth the cost of acetylene gas on a quantity basis. In addition it possesses a greater value because of its higher thermal value.

REPAIRING 9 1/2-IN. AIR PUMP CYLINDER HEADS

BY BENJAMIN GRADY

Air Brake Foreman, Atlantic Coast Line, Waycross, Ga.

The accompanying drawing shows a method of reclaiming top cylinder heads for Westinghouse 9 1/2-in. air pumps in which the reversing valve cap threads have been stripped or broken. The head is faced off 7/8 in., which is about half-way through the port which conveys steam from the main valve bushing to the reversing bushing. The inside of the reversing valve chamber is then threaded to a diameter of 2 7/16 in. and a depth of 1 3/4 in., the lower end of the threads passing through one of the smaller ports, as may be seen in the drawing.

After screwing in the steel bushing it is finished to the same height as the original head, the outside of the collar being left 3 1/8 in. in diameter. A 1/2-in. hole is then drilled through the side of the reversing valve chamber, one-half of the hole being in the collar of the newly made bushing and the other half in the original head, thus opening up the port communicating between the valve chamber and the reversing valve chamber. A piece of 1/2-in. brass tubing, the inside diameter of which is 3/8 in., is then driven into this port and the outside hole is tapped

and plugged with a 5/8-in. brass plug. This plug and the tubing serve as dowel pins to prevent the bushing from working loose. The small port near the lower end of the steel bushing is then opened up and the hole through the outer wall plugged with a 9/32-in. brass plug.

This method of repairing makes a stronger head than the

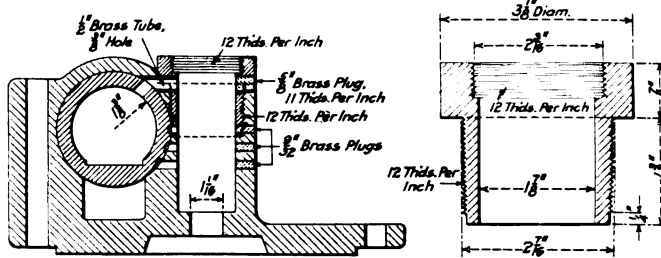

Method of Repairing Worn Air Pump Cylinder Heads

original, as the threads are in steel instead of cast iron, and a screw eye may be safely used to lift the pump off and onto the engine. This job may be done for about \$2.50, whereas a new head costs \$9, less all parts.

Y-FITTING FOR WASHING OUT BOILERS

BY PETER E. MCINTOSH

Boilermaker Foreman, Michigan Central, Kalamazoo, Mich.

A special Y-fitting for use in washing out locomotive boilers has resulted in considerable saving in the cost of boiler washing at this point. The roundhouse is equipped with the hot water washing and filling system, and the special brass fitting is attached to the washout line near the engine, thus providing two lines of washout hose, one of which is fitted with a 1 in. cut-off cock at the nozzle.

When washing out a boiler the plugs are removed from the four firebox corners and one line of hose is placed in the front

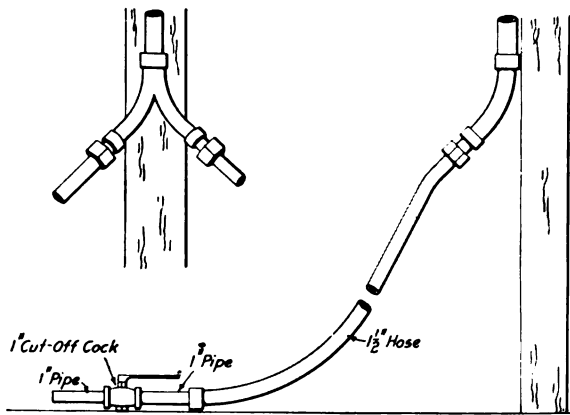

Arrangement of Y-Fitting for Washing Out Boilers.

water leg, the other being placed through the front flue sheet washout hole. While this is in operation two boiler washers remove all plugs above the running board and the hose fitted with the cut-off cock is then used along the top of the boiler, beginning at the front flue sheet. By the use of this device it has been possible to dispense with the services of one man formerly required at the globe valve in the washout line.

TESTING PISTON RODS.—An electro-steel company has announced the results of a series of tests on piston rods made of the steel it manufactures. The steel showed a tensile strength of 123,775 lb. per sq. in., and an elastic limit of 82,600 lb., with an elongation of 24 per cent in 2 in. and a reduction of area of 53 per cent. In a revolution testing machine 984,933 revolutions were required to break the test piece at a stress of 30,000 lb. per sq. in. This steel, which contains manganese, is produced in an electric furnace.—Power.

HOW CAN YOU HELP THE APPRENTICE?

The Prize Letter and Three Others Which Were Received in the Competition on This Subject

As noted elsewhere in this issue 18 letters were received in the letter writing competition on "How Can You Help the Apprentice?" Four of these, including the prize letter, have been selected for publication in this issue. The other letters, in whole or in part, will appear in the November and December issues.

SYMPATHY AND PRACTICAL CO-OPERATION (PRIZE LETTER)

BY JOSEPH SMITH
Baltimore & Ohio, Lorain, Ohio

May I, as a voice from the ranks of the railroad boilermakers, make a few suggestions as to how apprentices should be helped? Any boilermaker who learned his trade in the days of the hand-driven rivet, the rolled flue and hand-chipped and calked seam will bear me out when I say that to very few of us were given the advantages the apprentice of to-day receives. In those days it was a case of hard knocks and labor before one could rise to the dignity of a hand-riveter or calker. How proud we were when told off for the first time to drive rivets with one of the old-timers. How our chests would swell when ordered to take the firebox end of a set of flues.

Then another step up was to hold the straight edge for the boss when he was laying out a piece of work. "See all those lines, a regular labyrinth ain't they?" And that's all we would know, for the boss was very careful of the secrets of laying out. A layer-out in those days was looked on as some one to pay homage to, and never a one did we find that was willing to let us into the light of things. I have indulged in this retrospection in the hope that some of the boiler apprentices would read these lines and be awakened to the fact that advantages are open to them to-day which will lead to the high road for promotion.

Now, Mr. Boiler Foreman, you have your apprentices. Having carefully sifted the material, you assure yourself that you have the most promising boys to make boilermakers out of. In the first place, rest assured that you have no college graduates among them; not, however, but what a few would help in the boiler department. Let the boys understand from the first that you are their friend, gain their confidence, but allow no tattler or tale-bearer in the bunch. Insist upon attention to details, even of the so-called unimportant points of the business. You will need lots of patience, but a little extra trouble with a willing boy pays in dollars and cents to the company.

You will have some who want to know the why and wherefore of different processes. You, out of your knowledge and experience, can make many things clear to them so that they will not get shown in the way the writer did when learning the business. In taking out some broken stay-bolts I came across one that was completely broken off at one end and partly broken on the other. I wanted to know why it was so, so I took it to the boss and said, "That's funny, isn't it?" "Yes," was the reply, "there's lots of funny things in this world." And that's all the enlightenment I got on that subject.

Your apprentices will get the practical experience in the shop, but something else is required, and that is the feeling of fellowship between them and their foreman. Let them feel that they are free to bring their little troubles to you, establish a bond of sympathy and helpfulness between them and yourself, and the day will come when your apprentices will be a credit to you and an invaluable asset to the company. Encourage them to study the technical details of their business at home; there are plenty of good books to be had on the subject.

Start a class in "laying out" in your shop, beginning with the simpler problems. An apprentice who studies in such a class

will save much material, for he will not shear up a large sheet when a smaller one will do.

After twenty-three years in the business and a close observation of the different methods and results of handling the apprentice question, I believe that practical co-operation and sympathy with the apprentice will result in bringing the boiler department to a higher grade of efficiency.

THE VALUE OF INCENTIVE

BY J. CAMPBELL
Superintendent, Drifton (Pa.) Shops, Lehigh Valley Coal Company

April 1, 1915, I was appointed superintendent of the Drifton, Pa., shops of the Lehigh Valley Coal Company. At that time there were 19 apprentices employed; this number has been increased to 24, and will be further increased to 28, divided as follows: Three in the foundry, two in the pattern shop, one in the boiler shop, and the remainder in the machine shop, and two boys on probation in the car shop.

Our apprentices have for a number of years attended a school, under the supervision of the chief draftsman, every Wednesday from 12:30 to 1:30, the company paying them for the time spent in the class room.

I was strongly impressed with the intelligence and skill of some of the boys, and decided to do everything in my power to help them to a better education by endeavoring to arouse their latent energies in the direction of self-education.

We made the first effort in June by offering "one dollar" to the apprentice who would give the best suggestion as to how to repair a much distorted steel mine car frame which had been received for repairs; all answers to be turned in the next day in writing. To our surprise the boys took especial interest in the contest and nearly every one replied.

Anthony DeGrosse, a boy of 18, who had started his apprenticeship in the machine shop, May 1, 1915, presented a splendid pencil sketch with three pages of his own ideas as to how to repair the frame. He won the prize. There were so many good ideas presented that we decided to try again, and on July 22 offered "two months' time in any department of Drifton shops" to the apprentice giving the best suggestions as to how to repair a Jeansville pump to be on exhibition in the shops at the noon hour, or on idle days, permission being given to change the design of any broken parts, and also to give an approximate cost of overhauling the pump. All answers to be turned in one week later.

The boys became deeply interested and started at once to earn that change of position. Saturday following, being an idle day, they turned out in force and spent the morning on the pump, almost dissecting it to learn its condition. Two boys were on the job at 5:30 a. m.; one went to the Jeansville Pump Works, Hazleton, Pa., to learn about pumps, another to the colliery to examine the pumps, and by 10:00 a. m. they were nearly all studying and sketching the pump.

A committee of three, consisting of the foundry foreman, a draftsman and a master mechanic from one of our collieries, were appointed as judges. The contest was so close that it took the judges five hours to come to a decision.

Thomas D. Brobst, a young man of 20, serving his third year in the machine shop, was the winner. All the boys were commended for their work, and the management was urged to continue the contests. August 2 Brobst was started in the drawing room at his request. We now learn that the pump was the second style built by the Jeansville Company, and the first successful mine pump put in service.

We intend to continue these contests, and will also offer

prizes for the greatest improvement in penmanship and mathematics. We will try to stir the boys up to realize the need of a good general education to fit them for any position they may be called to fill in the years to come.

MODERN APPRENTICESHIP

BY ROBERT N. MILLER

Assistant Professor Machine Design, Carnegie Institute of Technology
Pittsburgh, Pa.

The success of any organization is dependent on the success of its individual units, and as such the mechanical organization of a railroad is dependent on the education and training of its men. One of the momentous questions of the day in connection with the efficiency of the mechanical department is not so much that of adequate supply of labor as the proper training of this labor so as to develop into the best mechanics for the future. The apprenticeship system of any organization can be divided into two chief divisions.

- (1) The selection of the apprentice.
- (2) The development or training of the apprentice.

The importance of careful selection of raw material cannot be too strongly emphasized, for upon it depends the ultimate success of the trained mechanic. Raw material suitable for apprenticeship must possess a reasonably good education (by which is meant, at least, completion of grammar school work) and show sufficient interest in the trade to warrant the employer in assuming the burden of training him in his particular trade, and not as is often the case, of merely serving out time and then leaving the service entirely on completion of the period of indenture. By investigating the environment in which a boy has been raised, his natural bents or aptitudes, and the general attitude of the parents or guardians toward the proposed trade a considerable gain can be made in the selection of proper material. Even with this preliminary investigation, a probationary period of service ranging from 30 to 90 days is of advantage to both the employer and apprentice in observing the development of dispositions and temperaments which have hitherto been dormant and which will later on have an important bearing on the quality of apprentice.

Again, it would appear that a systematic method of personal canvass of schools where prospective candidates for apprenticeship are to be found, by officials in charge of apprentice instruction, would be of considerable aid in education of the adolescent to the appreciation of the value of a trade in his life's work. By setting forth the advantages of a trade, the advantages to be derived from the system of apprentice instruction, the opportunities for advancement, and the assurance of steady employment, it is possible to stir up sufficient interest in the trades to guarantee the railroad an ample supply of high class mechanics.

The real work, however, begins after the boy enters the service as a full fledged apprentice, for from then on the quality of mechanic developed lies largely in the hands of the railroad through its instruction staff.

The assignment of the apprentice should, as far as possible, follow a systematic course to eliminate any tendency toward holding the boy too long at a particular machine or job to the detriment of other phases of instruction and to the disadvantage of other apprentices.

It is advisable that, in conjunction with the shop work or manual training which the apprentice receives, a considerable amount of classroom work and instructions should be given, so as to really make the apprenticeship school a sort of continuation school wherein the value of various methods of shop operations and the principles underlying them can be taught.

A regrettable condition of apprenticeship is often found wherein the apprentice is taken on, not so much with a view toward developing a mechanic for the future as toward filling a present day need for low-priced labor to the disadvantage of both employer and employee.

The development of the apprentice rests to a considerable

degree on the personal qualities of the apprentice instructor—his temperament, characteristics and enthusiasm in the work and welfare of those in his charge. By taking advantage of one of the predominating traits of adolescence—imitation—it is possible to thoroughly enthrall the boy in his work and in that way unconsciously have him striving to attain his highest efficiency. Instruction, which fails to include the historical and economic development of railroads, the improvements introduced from time to time, and the needs for future development, fails to give the apprentice a broad view of the field of his chosen occupation and it is not surprising that in such instances gross lack of enthusiasm is to be found.

Personal attention on the part of officials, and especially those from other shops, to the character of work done by the apprentice, as well as the mechanic, is bound to promote enthusiasm.

In order to develop a high grade apprentice sufficiently great incentives must be furnished and, of these, perhaps the most effective is that of increase in wages, or an early release from the period of indenture. Further, scholarships in technical schools are often given as rewards for highly satisfactory service. Incentives of this type are always productive of excellent results, as is borne out by experience on roads offering them.

GIVE THEM RESPONSIBILITY

BY CARLETON K. STEINS

Special Apprentice*, Pennsylvania Railroad, Altoona, Pa.

Apprentices should be handled in a manner that will arouse in them a genuine interest in their trade from the beginning, and hold it there. Interest in what they are doing will automatically produce better mechanics than the most painstaking arrangement of duties, which does not consider this as of first importance. It is a rare man, much less a boy, who can concentrate and give his best efforts without possessing some degree of enthusiasm for his work.

How to maintain interest in the apprentice's mind after the newness of things has worn off is the problem that should be constantly before every employer of apprentices. The best way that I know is to place responsibility on the young man, and give him tasks that carry with them an assumption that he has ability and initiative which his boss intends making good use of. The average boy will not betray this confidence; he will put his best shoulder to the wheel to do the job as the boss wants it and will take a pride in the finished work. Here you have the earnest effort that keeps a boy from becoming disheartened, and at the same time molds the best mechanic.

Responsibility should be placed on the apprentice as far as his ability warrants. Good business sense, if no other consideration, demands it. It is essential that the assignor of tasks to apprentices be broad-minded enough to size up the boys and get a fairly accurate measure of each one's ability and then this estimate should be his guide in directing their work.

Feeling as I do that the apprentice problem is more of a human one than of curriculum (the most studied and best organized courses have something lacking) I would warn against tactlessness on the part of the apprentice's immediate boss. Tactlessness, for instance, that goes into minute instructions and even demonstrations when an apprentice is being assigned a task, a task whose main operations the boy must have performed before, or at least observed their performance. A boy who is any good at all likes to do his own thinking—he cannot take interest and pride in a job in which no detail has been left to him to decide.

Keep apprentices away from piece-workers whenever possible; pieceworkers are usually too busy to show things, much less allow the boy to do things for himself. Letting the boys actually perform operations themselves cannot be urged too strongly—it has an influence for which no amount of observing can be substituted. The pieceworker's motto, "Good enough is best," may be permissible from an economic point of view, but it is a bad one to train a good mechanic on.

*Not written from that viewpoint, however.

"BIG BILL" AGNEW AND "BLUE MONDAY"

A True Story, Showing Clearly the Relation of
the Engine House Organization to Engine Failures

BY HARVEY DE WITT WOLCOMB

[This contribution was inspired by recent comments on engine failures in the Mechanical Edition. "Blue Monday" is known generally as the bad day in the roundhouse, and this story gives a remedy for it.—EDITOR.]

It was another "blue Monday" in the big roundhouse of the X, Y & Z R. R. at Greenfield, and even the elements seemed to combine their efforts to make it as "blue" as possible. It was one of those late winter days of March, when there was about 4 in. of slush on the ground, besides trying mighty hard to rain; but being too cold for rain it was more like hail.

Everything was covered with a thin coating of ice and the engines coming into the roundhouse were packed with snow; on top of this the heating system of the house was nearly out of commission and badly in need of repairs which had been neglected during the previous winter because of the rush of regular routine business and also on account of a rigid economy rule that had been in effect since the change of management. Such conditions as these were bad enough under ordinary circumstances, but on this particular morning the general roundhouse foreman, "Big Bill" Agnew, must "have gotten up out of the wrong side of the bed," as one of the machinists said, for Big Bill was sure "up in the air."

The fact is that Bill did get up a little late and had to swallow his breakfast in a hurry in order to get to work on time. When he started to check up the house for the day's work he was unable to locate his day foreman, but found everything completely disorganized, as usual. About 8 o'clock he got a telephone message that the foreman's wife was sick and that he would not be to work that day. This meant that the general roundhouse foreman would have to handle the regular day foreman's work in addition to his own numerous duties, and the two jobs combined were enough to drive a man crazy.

Lately it had seemed as if he would go crazy anyway, as engine failures were getting to be far too frequent to suit the management, and yet they were apparently tying his hands by cutting down his force and not carrying sufficient stock in the storehouse. Big Bill would not give in, though, for he knew that railroad men for miles around regarded him as one of the best "fighting" roundhouse foremen in the country, and he had the reputation of getting out of more work reported by the engineers than any other foreman on the system.

However, reputation was not helping him lately for he was getting up against it harder every day. Sometimes he thought that 12 hours a day, every day in the week, was too much for his physical strength, yet he wasn't losing any weight. He was still six feet tall and weighed 198 pounds, the same as he had for the past five years since first taking the job. Then again he thought that perhaps his inspectors, or box packers, or some of the other mechanics, were "laying down" on him, but this could not be true, for some of them had been working on their jobs for the past 15 years; in fact, were old shop mates of his before he was promoted, and he knew them to be faithful and loyal to his interests. He did realize, however, that the type of engines had changed materially in the past four years, being heavier and more complicated, and although he had carefully studied the new and improved equipment, it was getting the best of him, or his organization, and engine failures were a daily occurrence.

However, this morning Bill was far too busy to even "remember" about himself, but was on the jump every minute to keep "the ball rolling." About 9 o'clock he was called to the office to explain over the 'phone all about why the crack midnight passenger train had had a hot pin failure of 25 minutes; on ac-

count of his additional duties of that morning, he was, of course, unable to say anything to the master mechanic that would tend to clear up the mystery.

Immediately after this his leading boilermaker informed him that Train 38's engine, due to leave the house at 1:30 p. m., required two new grates and there were none on hand, nor even any that could be altered so as to be used temporarily. "In fact," the boilermaker added, "the storehouse is getting worse every day and we haven't had the right shape of grate for this class of engine for over a month and I am continually altering some other type to use."

A SURPRISE FOR BILL

At this point I am unable to write just what Bill said, but will leave it to the imagination of the reader, for Bill was one of those fluent swearers that could swear as fast as a horse could trot, and the kick on supplies, coming as it did on top of the nice little "call down" he had received from the master mechanic over the engine failure of the previous night, was the "straw that broke the camel's back," and Bill started for the storehouse "with blood in his eye."

Going to the storehouse with a "kick" had gotten to be a regular daily habit with Bill, and he had succeeded lately in virtually driving the old storekeeper out of the service by his abuse. Recently a new storekeeper had been appointed and Bill had not run across him as yet, but was in a very good mood for a first impression. You can imagine Bill's surprise when he beheld a "slight-of-frame," young-looking man holding down the storekeeper's chair; but Bill had to take his vengeance out on someone, so he started on the new man.

What Bill said was enough. He started in on the history of storekeeping from the time of the ark down to the present time, when there "wasn't enough material of the right kind on hand to make a pair of creepers for a humming bird." During his abuse he noted with quite some surprise that the new storekeeper did not try to crawl in the wastepaper basket or slide under the desk, but simply sat still, idly glancing over some mail on his desk; these actions were such a shock to poor Bill that for once in his life he was thrown completely off the track of his thoughts and he finally stopped in confusion at a loss for proper words to express his feelings.

At this point the new storekeeper looked up at Bill and told him that he was paid to run the roundhouse and not the storehouse, and that he was going to run the storehouse in an efficient manner, which was something that Bill wasn't doing with the roundhouse. "In fact," the storekeeper said, "I have here some of the samples of your mismanagement. Here is a letter from your boiler foreman to you, asking to order 24 grates for a class of engine that has only been here once and is not liable to come again, as it is a type that cannot be used successfully on your division. I am not going to order these grates, as I don't believe you looked into the matter at all, but simply O. K.'d the order on the strength of your boiler foreman saying he wanted them. Furthermore, I intend to ship away about two-thirds of the stock we are now carrying at this point, for I am finding that about 90 per cent of the rush material you have ordered has been handled in this manner and we are showing such a large amount of material on hand that when we do ask headquarters for a rush order, they look up our stock lists and think that of the large amount of supplies we are carrying there is surely some piece that can be slightly altered to meet our rush requirements. Now, get out, for I am busy, and some day

when you are in your right mind come over and we will go over our actual requirements so as to protect ourselves against undue shortages."

Poor Bill! To be called down by a young whipsnapper like the new storekeeper was bad enough, and besides there wasn't one cuss word used for emphasis that Bill could start any argument on. It was a straight presentation of facts and Bill was big enough to realize it. In the past, with the old storekeeper on the job, he had had his own way and always had put the blame on the store department, but this new man had "shown him up" in such a strong light that there was no "come back."

Bill returned to the roundhouse and for the balance of that day really didn't know whether "he was coming or going." He could see the logic of what he had been told, yet it hurt his professional pride to think that a young man who had not been in the business very long could tell him anything about how to run a railroad. Sometimes Bill thought he would go over and clean up the floor with the new man; then again his better sense would show him that perhaps he was just a little wrong and maybe he didn't know how a storehouse should be run.

Business that day seemed to go on just as the storekeeper had inferred; that is, everything seemed to go wrong, and poor Bill was tired out when night came. After he had had supper he began to go over the events of the day and compare them with past days, and he found that every Monday was a "blue" day, and getting worse every week. When he would try to think of excuses for this and that matter, it would work out that he was the one to blame and, in fact, he saw very plainly that he was slipping back on his job, and unless some miracle happened in the near future he would be looking for a new position.

Now, Bill was no fool. In fact, he was a very bright man, and when morning came he hiked right over to the new storekeeper's office to have a sensible talk with that young man. Bill opened up by asking just what the storekeeper had meant yesterday when he accused him, the best roundhouse foreman on the system, of mismanagement?

BILL GETS SOME GOOD ADVICE

"Well," replied the storekeeper, "you are running your job on the 'one man' idea and the plant is far too big for one man to bear all of the burdens. In other words, when you stop the entire plant stops, and when you make a mistake the entire place goes to pieces, for you have not trained your help to think and plan for themselves. Take, for instance, the case you came over to see me about yesterday. That case was the oversight of your boiler foreman. Why didn't he know that there was a shortage of grates for that class of engine and hurry them up instead of waiting till they were all gone and then put the blame up to you? Why were you out of sorts yesterday and not in condition to handle one job, let alone two jobs? I know why and will tell you. Your day foreman laid off and instead of his having some man broken in to take his place in just such emergency cases, he left it up to you and you tried to hold both jobs, which didn't give you time enough to properly handle any job. You had to jump at conclusions and your foremen knew it, so they took advantage of you on everything. Take your work all the way down and you will find where you have been the 'goat' and the fellow who was actually responsible has 'slipped' it over on you."

Bill began to see a great light, and after thanking the new storekeeper for the interview he returned to his office and locked himself in for the balance of the morning.

What Bill thought of, or what he did in the office that morning, I will never know. However, it was a far different Bill that came out than the one that had gone in. From that moment he seemed possessed with only one idea and that was to take the "blue" out of "blue Monday," or any other day for that matter. He called his foremen together and lined them up to immediately break in an "understudy" or assistant foreman, and also to line up the men so that every job could be

covered at a moment's notice without any confusion.

At first the foremen remonstrated, saying that it could not be done, and that some of the workmen would get "sore" if they had other men that knew all about their jobs. One foreman said that he would lose his boilerwasher at once, for that man had had his job for years and had now gotten a good thing for himself, and so should reap the benefit.

"That's just the point that I want to bring out," said Bill. "When your boilerwasher lays off we are tied up and it is up to me to answer why we are holding engines, and from now on I want at least four men broken in on some of the more important jobs." I cannot begin to tell of the things that Bill straightened out, but the results soon began to show that Bill was getting his reputation back again.

REAL CAUSE OF ENGINE FAILURES

Some months after Bill started to chase "blue Monday" I met him in the roundhouse, and such a change from the old Bill! He had changed from a man that was always in a hurry not having one moment to waste, to a man that apparently had nothing on his mind, or nothing to do. I could not help speaking about the new order of things and Bill insisted on taking me into the office to tell me how it had come about.

"Do you know," said Bill, "that I was on the road to the crazy house last spring and today I have one of the best jobs in the country. I have discovered that the real cause of engine failures is not poor engines or enginemen, but to a great extent the result of the roundhouse organization. Last spring this roundhouse was the cause of daily failures because it was being run on the one-man idea, and there was so much work for that one man that he couldn't give enough time to any one job to handle it successfully. Today everybody is working together.

"I used to be very careful to keep my office locked and not let any of my foremen see my correspondence, but today everybody has access to my office, for we are all interested in the work now. Several times my foremen have read my correspondence on different matters before I have, and the result has been that they have had a chance to work up the necessary information before I asked them for it.

"Another thing that keeps everyone in line is the assistants for every job we now have. The assistants are good men and well capable of judging their bosses' mistakes, so that keeps the boss on the jump or else the assistant will get his job.

"I found that my inspectors were not interested in their jobs, but were simply putting in ten hours' work with the only thought of protecting themselves in case any work got by them, and also to see how quickly they could get out after the six o'clock whistle blew. I put it up to them that their jobs depended on the good condition of our power and that their reputation was to be based on how the power was kept up. This meant that they would have to keep their eyes open and not only report the work, but in a way see that it was repaired properly after they had reported it. By presenting the matter in this light the inspectors saw just how they stood and began to work together.

"Last night, after six o'clock, my head inspector went over to an engine to see that some work that had been reported by him was done properly, and he did it on his own time. I told him he had better see the foreman about it, so that he would get paid for the extra time, but he wouldn't listen to it and told me that he would rather have the job right than bother with a half hour's time. You see how that works now, for this is the forty-second day that we have not had a failure of any kind.

THE ENGINEMAN "SEES A NEW LIGHT"

"There is another big wrong that I straightened out: Engineman Johnson was a 'kicker' from away back. He and I were always fighting over the jobs he wanted done that I didn't think necessary; in fact, we wasted a lot of valuable time over nothing. One day I told 'Mr. Johnson' that I was through fighting him and that from then on we would do every job that he reported.

He was so pleased to beat me that he didn't know what to do, and at first was going to have his cab painted on the inside with gold leaf and have a Brussels carpet put on the floor.

"That's all very well, Mr. Johnson," I said, "we will gladly do it if you will write it down. We are going to keep an account of the cost of your engine repairs for the next year and you will be responsible for the cost outside of the few emergency repairs found by our inspectors. In other words, we intend to loan you an engine and you are to show this company whether you are a careful operator or an expensive man to have on the road."

"You could have bought that engineman for about three cents then, for he had never thought of the cost of all the imaginary jobs he had been reporting. At first he wouldn't listen to my plan, but he finally shook hands on it and today he doesn't average two reports a week, yet he hasn't had a failure since our agreement. He used to always report a pound on the left side or an imaginary blow, but today he is mighty sure of his job before reporting it and is very proud of the low cost of his maintenance.

"This same rule worked with our 'pool' enginemen. When they found that we had each man listed by the cost to maintain the engines they were running, they soon learned to report only such jobs as were necessary and cut out a lot of reporting of imaginary pounds and blows. They found that we were doing our work well, and if they reported something it was sure to be given attention before the engine made another trip. They have learned to help themselves now and are working in our interests by trying to work in their own.

"Another thing that used to worry me a good deal was the locating of the different foremen, and I suppose they in turn had a hard time to find me when they had something to take up with me. This big roundhouse covers a lot of ground and I used to run my legs nearly off looking for this and that man. Today I have eight telephones installed around the house at different points, equipped with large gongs, and each foreman, even to myself, has a certain number of rings. Now, when I want to reach any of my foremen I have only to step to the nearest telephone and ring his number. No matter where he is he can hear his ring and will answer so that we save a lot of time in trying to find each other. This is not only a life-saver, but is also a great time-saver and paid for the installation in one month.

"I have so much time to myself now that I can personally check up my individual workmen. For instance, I found a machinist who had been working here for about three years that was not reliable. He was not turning out his work to stand up, and after several trials I had to let him go. I have hired a man in his place that is a 'dandy' and is interested in his work. This new man is not working for payday, but is working for my interest and is one of the small units that is helping to hold down our engine failures. This is the type of man that prevents engine failures, and yet some say that engine failures do not start in the roundhouse.

A DOCTOR FOR SICK JOURNALS

"I got after my box packer and told him that he was not hired to 'stick' around for 10 hours each day, but was paid to 'doctor' sick journals, and if the sick journals did not get well I would change doctors. Do you know that that man didn't even know the cost of the oil and waste he was using, although he had been packing boxes for the past 10 years? The very first month after I gave him some personal instructions in correct box packing and the economical use of oil and waste, he saved \$342 for this company and I promptly raised his wages three cents an hour.

"That man has found out that it pays a good dividend to get interested in his work, and he knows that as long as he keeps the failures down and saves money in the use of oil and waste I will keep on raising his wages, even if I have to pay him 50

cents an hour. You see, I don't have to watch him now, for his work shows for itself. Before I put this plan into effect this same man was continually complaining because of the great amount of work he had to do. Very often he would look me up to tell me that some engineman had reported 'all tank cellars packed' and he knew it was unnecessary to pack those cellars. Today he is so interested in his work that I have known him to look an engine over for fear that the engineman had forgotten to report the cellars packed, or that, perhaps, he would find some little defect that he could remedy before it got out on the division and caused a failure.

"This same rule works with the house force. In the old days the house foreman was constantly complaining about how slow the engines were coming into the house from the coaling and ash pits; if I asked him to send a man out to help on the ash pit he would nearly have a fit. But today it is far different. If the ash pit or coaling pit is behind, or working short handed, my house foreman knows all about it and will send the necessary help out without saying a word to me, for he has learned that he is the man to get the benefit of the engines coming into the house on time and that the best way to overcome a grievance is to invent some scheme to overcome it.

"This roundhouse is like one big family and the success is not on account of one man, but on the united efforts of us all. My foremen don't depend on me to do their work, but are using their heads for themselves.

A MISTAKE TO PASS THE BUCK

"Talk about inventing schemes to get around some grievance; one day, in looking through my desk, I came across a big pile of inspectors' reports covering the inspection of engines that had just been turned out of the back shop. To read these reports you would naturally think that the engines were just due for general overhauling, instead of just coming out of the shop. I could not help thinking of all the time and energy wasted on them, for conditions are just the same now as they were when we first started to make these inspections. We had gotten in a 'rut' on reporting work and the back shop force looked on us as a gang of 'kickers,' so we might as well have saved our strength as to send in the reports.

"I could see that the secret of some of the bad work from the back shop was the same as in my own case, that is, the foreman had too much to look after and he couldn't give the proper time and attention to his work. Complaining of a bad job after it is done doesn't help matters, for it has cost time and money to do it wrong, and it will cost a good deal more money to make it right, so the proper time to have it made right is the first time it is being done.

"To protect myself I assigned one of my best inspectors to the back shop to follow the work as it was being done in the shop. The results of this experiment were very gratifying, for we stopped the bad work in the back shop and it is a common occurrence for us now to take an engine right out of the shop and put it out on some light run without any breaking in, as we used to do. The back shop takes the praise for this work, but we know that it was just another case of inventing a scheme to overcome a complaint instead of 'passing the buck.'

"In the storehouse we now have nearly all the material we require and yet the storekeeper informs me that we have reduced our balances by over half. I found that some foremen were simply 'hogs' when it came to ordering material. They would require five pieces of some casting and would order at least 24 pieces so as to be sure to have enough. Some of the foremen had cupboards around the house stocked up with a great number of costly finished brass parts of which they would not use more than one piece in a month; on the other hand I found some foremen that could not see far enough ahead to order the necessary castings that were required for everyday use. This has all been straightened out now and each man has been given a lesson on 'what to order,' 'when to order,' and 'how to know the cost

of too much ordering.' To-day when we ask for a rush shipment we get prompt delivery, for headquarters knows that we are on the job and what we say is 'right,' there isn't any 'come back now.'

"Knowing when you are right and saying the right thing also helps when we make any recommendation for overcoming of weak design in our engines. I never realized the vast difference of opinion that could exist among mechanics when it came to making recommendation to better a weak point in our equipment. I can see now some of the absurd recommendations that I used to send to headquarters on the suggestion of my foremen, and I don't blame the higher officers for throwing them in the waste-paper basket, for I know that they were way out of reason. To-day that kind of business has been changed and we go into everything very carefully before saying anything and the result is that when we do say something, we get prompt action.

"In conclusion, let me tell you that from my own bitter experience I know that engine failures are to a great extent caused by poor attention in the roundhouse and that roundhouse foremen are 'made' and not 'born,' as I was always lead to believe. The successful foreman is not the smooth talker or good friends to everybody, but is the man who can talk 'business' on the dollar and cents basis, and his reputation should not be based on how nice he can put the trouble 'up to the other fellow,' but on how easy he can invent some little scheme to overcome the trouble and thus cut down failures and the unnecessary throwing away of good money."

With this, Bill threw away his cigar butt and after telling me to come back some other day for the rest of his story, started out to make the rounds of one of the nicest roundhouses in the country.

RAILWAY REPAIR SHOP ORGANIZATION

BY HENRY GARDNER

The old-fashioned railroad shop organization is well known; it consisted of a shop superintendent, or master mechanic, followed in line by an assistant superintendent and general foreman and a number of shop foremen, one for each department. In a shop of this kind the superintendent, assistant superintendent and general foreman have to bear all the burdens of administration and supervision; frequently there is no assistant superintendent in the organization, the whole load being carried by the superintendent and general foreman. Under this type of strictly line organization there are great possibilities for a glaring waste of time and effort by the supervisory force. These overloaded officers, continually goaded for output, must at the same time hold discipline meetings every day and must pass on all applicants for employment; they must be familiar with all piecework schedules and continually add new prices; they must see that all belts, motors, machines and cranes are kept in repair and must handle the apprentices, constantly instructing and moving and encouraging them.

It is safe to say that no one man, or three men, can do justice to all of these duties in a shop of any appreciable size, and it is a foregone conclusion that they will frequently overlap one another in the performance of their work. An instance is recalled where three men in an old-fashioned line organization shop went over the same ground daily, one after the other, and often it was found that a sub-foreman had been told to do the same thing by each one of these three men in succession.

In the majority of railroad shops to-day the strictly line organization is in effect; there is no attempt made to plan, schedule or despatch the work in the various departments and almost any foreman can hire or discharge men, with or without just cause. The result of this state of affairs is as might be expected—low output, great waste of labor and material, with a high cost of repairs, and a general lack of system and order. The machine equipment is neglected or repaired in a makeshift

manner and the money wasted in misuse and abuse of belting alone would pay for many new machines in a year. Cutting tools are dressed and hardened by guess, by the eye; no such thing as an electric furnace or a pyrometer is known.

In this same hypothetical but very typical shop, apprentices, if hired at all, are exploited by being kept on one machine for a year or more, and no serious attempt is made by any one to properly instruct them. If the shop is run on a day work basis the supervising officers must be constantly on the move to maintain the output; if the shop uses piecework to any extent an eternal personal vigilance must be exerted to keep up the quality as well as the quantity of output. These old-fashioned practices are now conceded to be wholly inadequate, especially for the larger shops, and the strictly line organization must give way to the composite line and staff organizations if the maximum quantity and quality of output, at a minimum cost, are to be obtained.

A proper organization for a large railroad locomotive repair shop is shown by the accompanying chart. Here is a combination line and staff organization. The superintendent of shops has an assistant who has a general foreman next in line in charge of all departments, as is customary. But the staff is the vital part of the whole organization, and is directly responsible for the economic and effective management of the entire plant; the line, below the superintendent, is wholly in charge of output.

On the staff are six supervisors and a chief clerk as follows: A supervisor of piecework, or other wage payment system; a supervisor of routing, scheduling and despatching in all departments; a supervisor of apprentices whose important duties are well known; a supervisor of tools and machinery in charge of the repair and purchase and installation of all new machine and hand tools, cranes, etc., about the plant; a supervisor of manufacturing who is in direct charge of all shop orders and manufactured material either for outside shops and enginehouses or for local consumption and stock, and finally a supervisor of labor, whose office may be called the employment department; this man employs and discharges all men and administers discipline for all employees in and about the plant. The duties of the chief clerk are well known and established. The form of organization shown by the chart is distinctively up-to-date and is representative of tried and successful types. With this arrangement the several and specific duties of each staff man are carefully defined and all overlapping and doubling of work by the supervising force is eliminated.

The first duty of the superintendent of a locomotive repair shop is to study quantity and quality of output. He should spend at least three-fourths of his time on this work, if he is to actually earn his salary. All clerical work, letter writing, etc., performed by a shop superintendent is a dead loss to the railroad and nine-tenths of this work should be turned over to his assistant and his chief clerk. A railroad shop superintendent has been known to spend an entire day with hammer and chisel and file surrounded by a loyal and admiring group made up of the assistant superintendent, the general foreman, the erecting shop foreman, the machine shop foreman and two skilled mechanics. But what became of the shop and the departments controlled by these men during that day? Obviously the loss to the company measured in dollars would be considerable.

The modern railroad shop superintendent must be more than a practical man and a good handler of men; he must be a superintendent in the same sense of the word as applied to similar positions in the strictly manufacturing shops. What else is a railroad shop but a manufacturing plant, and how is it in any way different in so far as opportunities for saving and economy are presented? The shop superintendent should spend a part of his time planning and developing original improvement work and he should have available up-to-date records of the output in all departments and should keep close watch over the cost of repairs. In connection with these duties the following records are

suggested for the superintendent's office; these may be expanded or modified to suit local requirements, and they are better made in chart form, as a diagram gives accurately an exact picture of conditions which cannot be so impressively presented in any other manner.

For a nine-hour day these formulae should be worked out each month and platted in diagram form:

- (1) $\frac{\text{Total engines out per month} \times 9}{\text{Total man-hours per month.}} = \text{Engines out, per man, per day.}$
- (2) $\frac{\text{Labor cost (payroll) per mo.} \times 9}{\text{Total man-hours per month.}} = \text{Labor cost of output per man per day.}$
- (3) $\frac{\text{Material cost per month} \times 9}{\text{Total man-hours per month.}} = \text{Material cost of output per man per day.}$
- (4) $\frac{\text{Labor cost per month}}{\text{Engines desp. per mo.}} = \text{Labor cost per engine despatched.}$
- (5) $\frac{\text{Material cost per month}}{\text{Engines desp. per mo.}} = \text{Material cost per engine despatched.}$
- (6) $\frac{\text{Man-hours per month.}}{\text{Engines desp. per mo.}} = \left\{ \begin{array}{l} \text{Number of hours it takes one man to turn} \\ \text{out one locomotive.} \end{array} \right.$

The above six formulae may be further subdivided to include each separate shop or department as the need for such data arises, or if a special study of some one department appears to be demanded by lowered output or faulty conditions. The percentage of material and labor costs should also be carefully watched and a chart may be made to show this each month. For example, the total material cost for all repairs for one month may be \$30,000, and the corresponding labor cost \$50,000. From this it is evident that material costs are running 37½ per cent of total and labor costs 62½ per cent, which may be considered a fairly good condition for the average shop to-day.

As indicated by the organization chart the responsibilities of the assistant shop superintendent are the same as the superintendent, since in the event of the superintendent leaving suddenly or gaining a promotion the assistant superintendent should im-

mediately fill his superior's position without appreciably disturbing the organization or the quantity and quality of the output. A close, individual, departmental study of this kind has never failed to result in a great reduction in manufacturing costs as well as an increase in general effectiveness and frequently a decrease in payroll as a by-product. If a month cannot be spared, two weeks, or even one week, spent by the assistant superintendent in each and every department of the plant each year will work wonders. Finally, an up-to-date shop superintendent, as well as his assistant, should visit other shops frequently and keep constantly posted as to the best methods and practices; they should also read the technical papers carefully, always watchful for labor saving devices and methods for cutting costs and eliminating wastes.

Next in line to the assistant superintendent is the general foreman. He is one of the most important men in the organization, and his duties have wholly to do with the prime object of running the shop, viz., to deliver repaired locomotives. He must be of an extremely active or motive type and must have exceptional ability for instructing and handling men and increasing production. The general foreman works with the seven staff men as occasion arises, in an advisory capacity, but he does not report to any of them or direct them. The general foreman runs the shop with a line and staff organization exactly as in the old-time line organization, with the exception that a multitude of duties are removed from him so that he becomes virtually an output specialist.

The general foreman and the supervisor of the planning department should be closely allied and preferably their offices should open together so that the daily delay reports may be taken up at once by the general foreman and the causes traced and rectified. It is good practice for the supervisor of the planning department to give the general foreman a slip each morning stating the number and class of repairs of engines that are to be

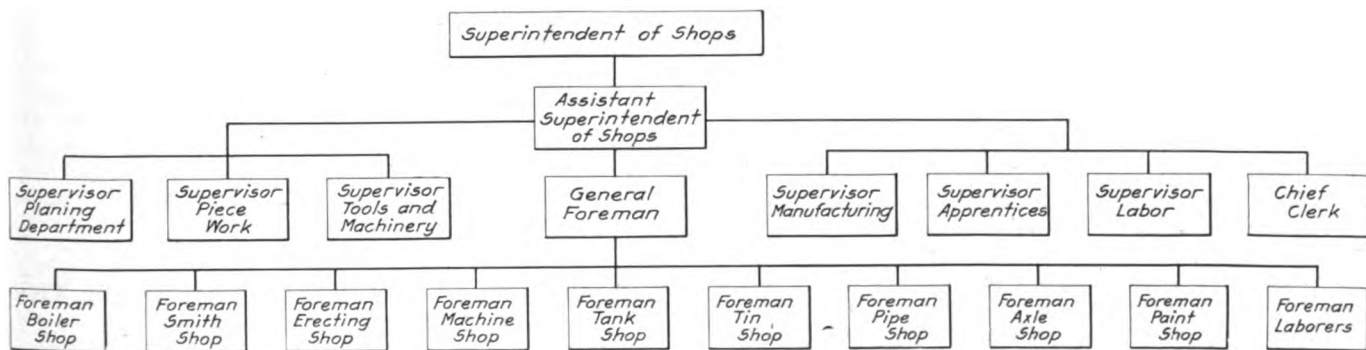

An Ideal Form of Organization for a Large Locomotive Repair Shop

mediately fill his superior's position without appreciably disturbing the organization or the quantity and quality of the output. The duties of the assistant superintendent should be primarily to run the shop and get the required output. He should study and arrange for the charts and data required by the superintendent and should aim in every way to run the entire plant as if his superior were not there to supervise him. A great deal of time is wasted by shop superintendents and their assistants in habitually walking about the plant visiting every department superficially each day. The gain to the shop as a whole by this procedure is practically nothing. Many a railroad shop superintendent and his assistant walk miles, day after day, conscientiously going over the same old beaten path at about the same hour at least twice each day; the foremen and workmen anticipate the visits and, of course, are all on their best behavior.

The most important duty of an assistant superintendent in any organization should be to make an exhaustive study of each department of the shop; say the boiler shop, to start with. He should turn over all other routine duties to the chief clerk and staff men and general foreman and live for a month in this department, working with the foreman as his assistant, in a sense, for the entire day, if it be from 7 a. m. to 6 p. m. In this way an exact knowledge of details may be obtained and faults corrected

brought in, and it is the duty of this office to see that the departments are at all times equalized. The duties of the staff men are indicated by their titles; the scope of this article will not admit of further details.

The form of force organization required below the general foreman is so varied and depends so much upon local conditions that it must be sufficient to give simply a few general suggestions. The writer has made more than fifty individual charts for a single plant, illustrating departmental apportionment of skilled mechanics, shop hands, or handy men, and laborers; each shop must work these details out for itself—no hard and fast rules can be laid down. Great care should be taken to organize the working gangs with the proper proportion of skilled and unskilled men. Do not have sub-foremen, if needed at all, with no men reporting solely and directly to them; a sub-foreman, or assistant foreman, should always have full authority to direct the men under his charge. Workmen should not be required to report to or receive orders from more than one man, if friction is to be wholly eliminated. The working forces should be divided into small gangs under working leaders, which is better than dividing the whole responsibility between two or three leading foremen; this arrangement will cut down the cost of supervision and place the responsibility and supervision more nearly

where the work is actually performed. Specialization is undoubtedly correct for the railroad shop and it must be developed to the fullest extent in every department. Making one man responsible for one class of work not only increases his earnings and his interest in his work, but it enables him to do the best work in a manner satisfactory both to himself and to the railroad. Over specialization is preferable to under specialization.

There is always some discussion as to the relative merits or demerits of two well-known forms of erecting shop organization. The first aims to have the pits divided into blocks of six or eight pits and places one foreman in charge of each block. The other method considers the whole erecting shop as a unit, and has the foremen in charge of gangs, which do special lines of work, and travel up and down over the entire shop, visiting every pit in the order that the work is required. In a shop using a scheduling and despatching system, the former organization is preferable, since accurate comparisons of output for each foreman may be obtained and platted from month to month and a close supervision of his record is very stimulating; moreover, a friendly and healthy rivalry is maintained, thereby keeping up that all-important enthusiasm and "esprit de corps" which, after all, is the great fundamental cause for human excellence. Engines coming into the shop should be divided equally between the foremen as far as possible, so that no one man will obtain unfair advantage due to improper selection and distribution of the repairs.

More important even than the distribution of the force organization of a railroad shop is the planning and despatching department in charge of one of the staff supervisors, reporting to the assistant shop superintendent. The work of planning for the admission of engines to the shop naturally assumes more importance than the correct placing of forces, since it is easily possible to bring in too many engines requiring one kind of repairs and thereby disarrange and disorganize the most carefully planned and effective grouping of forces which may have been established to meet certain fixed conditions. The balance of a shop plays a most important part in its successful and economical administration and this is where the supervisor in charge of scheduling and despatching comes in; he must, as far as possible, keep the ratio of classified repairs constant and change that ratio only as may be necessary to prevent overloading some department which may have unexpectedly fallen behind.

For example, let us assume that a shop has been very carefully organized, a man clipped off here or added there until the entire plant is working at maximum efficiency. Then let us assume that 45 per cent of all engines turned out are to have new fireboxes, that 15 per cent are to have new cylinders, that 10 per cent are to have one or more new firebox or flue sheets, and that 30 per cent are to receive simply general repairs to machinery with flues removed and safe-ended and with tires turned. Now let us suppose that the exigencies of the service make it impossible to obtain for this shop more than 20 per cent of engines needing general repairs and that 55 per cent of all engines arriving need new fireboxes, and that 25 per cent need new cylinders; what, then, for the time being, has become of our carefully planned organization both as to men and machines? The intelligent selection of engines has a very noticeable effect on the cost of repairs as well as on the mean output; this is much more apparent in large shops where the organization is less flexible and usually highly specialized.

A locomotive repair shop is primarily a plant for manufacturing and maintaining power units needed for marketing the commodity, transportation, which the railroad company sells to the public, and in order to enable the company to sell its product to the best advantage the shop must at all times be ready to supply the operating department with the locomotives needed. This demand for power varies appreciably with the seasons and other causes, national and international, so that it is not always possible to keep a fixed percentage of engines of certain classes available for shopping, which have also made their required mileage in

service. The division superintendent and the superintendent of motive power should, however, co-operate closely with the local shop management, as no shop can deliver a constant maximum output from month to month which will satisfy the operating officials if it is not properly supplied with the kinds of repairs for which it has been organized. The ideal state of affairs exists when engines come in for repairs in a constant flow from month to month, and there is in normal times for every railroad a nearly constant direct ratio between the number of locomotives in service and the number requiring repairs; so far as conditions will allow, this ratio should be maintained.

Planning, scheduling and routing and despatching may be depended on to suggest and create the force organization needed. To a degree the organization will automatically adjust itself to the many variable working conditions so plainly brought to light by the accurate records resulting from the systematic scheduling and routing and despatching of all operations and material through all departments of the shop. With one well-known form of modern routing system the use of the despatch board tells at once which department is late or ahead and, provided the shop is using the normal repair ratios, suggests the changes in organization or equipment necessary to build up a department and consequently equalize the shops. The best shop organization can make but an outward show of efficiency without a planning department as outlined. To the casual observer the shop may be speeded up to its maximum intensity, but a careful analysis of conditions will soon expose many weaknesses and wastes of labor and material.

Modern combination staff and line organizations must be more generally employed if our railroad shops are to keep pace with the increasing demands made by the management for reductions in maintenance costs needed to offset government regulation of freight rates and the ever-increasing demands of organized labor. Finally, the statement may now be made authoritatively that increases of output up to 25 per cent have been recorded in several large railroad shops using in greater part the modern organization described in this article, and it is beyond argument that similar or greater increases in output, with consistent decreases in labor and material costs, may be assured to any large railroad shop whose officers and their superiors have the foresight and courage to adopt these correct principles.

CLOSING VALVE MOTION LINKS WITH THE OXY-ACETYLENE TORCH

A very simple method of closing solid valve motion links is in use at the Sayre, Pa., shops of the Lehigh Valley Railroad. When doing this work by heating the link in a fire, considerable time is required and the wearing faces of the link require re-hardening after the closing operation is completed. With the oxy-acetylene torch the ends of the link are heated to a red heat at the points indicated in the drawing, the depth of the heating depending upon the amount of shrinkage required to close the link to the desired dimensions. The remainder of the metal in

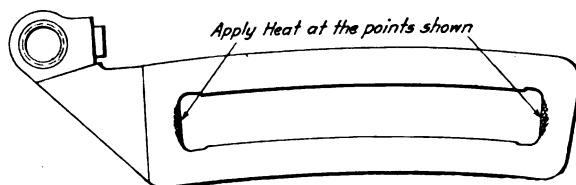

Link Showing the Point Where Heat is Applied

the end of the link remains cool and upsets the heated metal, which in cooling shrinks and closes the link. The time required is from five to eight minutes at each end. It is possible under certain conditions to do the work with the link in position on the engine. This method was developed by J. W. Riley, blacksmith foreman at the Sayre shops.

MASTER PAINTERS' ANNUAL MEETING

Vehicle Tests, Flat Color vs. Enamel Color, Design and Protection of Steel Passenger Cars, Piece Work

The forty-sixth annual convention of the Master Car and Locomotive Painters' Association was held at Detroit, Mich., September 14-16. H. Hengeveld, first vice-president, presided under the direction of T. J. Hutchinson, the president, who on account of illness was unable to carry on the physical duties of a presiding officer. The convention was opened with prayer, and the association was welcomed to the city by the mayor, Oscar C. Marx.

President Hutchinson, in his address, commented on the valuable work the Test Committee of the association has done in testing the various kinds of paints placed on the market for different classes of service. He favored further consideration of standard letters and numerals for stenciling all classes of freight cars, believing that there is yet much to be done in providing a more legible letter and numerals with the ultimate advantages of reducing the chances for error when recording car initials and numbers.

TEST COMMITTEE REPORT

The test committees of the several master painters' associations have devoted considerable of their time to the study and testing of the various kinds of material which make a paint pigment. This is also true of Committee D-1 of the American Society for Testing Materials. The information obtained by these tests may be summed up as follows: First, a composition paint made from a combination of several pigments will give better results than a single pigment paint; second, the pigments contained in a paint should be selected to meet the requirements of the service and the nature of the material it is expected to protect; and, third, carbon is not a rust inhibitive pigment and it is generally acknowledged that carbon paints do not make a good primer for steel, but there is no doubt but that carbon paints make the best over or body coating for steel structures exposed to the action of alkali or acids. Tests have proven that paints should be selected to meet service and climatic conditions. With these generally accepted facts as a guide it is believed that some time should be given to the study of paint vehicles.

The efficiency of linseed oil for paint purposes can be greatly increased by different forms of treatment and the treated oils properly thinned will produce a better paint vehicle at a reduced cost than can be obtained by the use of raw linseed oil.

In the development of these methods of treating linseed and other oils lies the future progress of the art of protective paint making.

The following is the report of tests of prepared films of linseed and other oils treated and non-treated:

Film 1—Linseed oil heated by electricity, and oxygen blown through it. This makes a heavy viscous oil which was mixed with equal parts of gasoline. A piece of the film weighing 27.5 grams was submerged in water for 72 hours and weighed, when taken out, 28.6 grams, increasing in weight 4 per cent.

Film 3—Linseed oil made by regular process, aged two months and then burned by special process until all the moisture had been removed and the oil had assumed a certain body. This was thinned with one part gasoline to two parts oil. A portion of film submerged in water 72 hours was found to be practically waterproof and very elastic.

Film 4—Linseed oil produced in the regular way, aged two months, then given an oxidizing treatment. This was mixed five parts oil to one of gasoline. Submerged in water 72 hours, increased in weight 3.5 per cent. The film was elastic.

Film 5—Linseed oil, aged two months, chemically treated to remove all of the mucilaginous matter and again aged four months and heated over fire from six to eight hours at a temperature of 600 degs. F. This was mixed two parts of oil to one part of gasoline. The film was submerged in water 72 hours increasing 3.95 per cent in weight. The film was elastic.

Films 6 and 7—Mixtures of China wood oil, varnish gum and linseed oil. Submerged in water 72 hours, film 6 increased 8 per cent and film 7 increased 4 per cent in weight. The films will stretch twice their own length.

Film 10—China wood oil thickened by heat and mixed 5 parts of oil

to one part of gasoline. The film was submerged in water 72 hours and increased 1.9 per cent in weight.

Film 11—Linseed oil heated to a comparatively low temperature with air blown through it and mixed 5 parts of oil to two of gasoline. Increased in weight after being submerged in water 72 hours, 2.8 per cent. The film was elastic.

Film 12—Commercial boiled linseed oil. This film increased in weight 14.4 per cent after being submerged in water 72 hours. The film was very easily torn while full of water but when dry, fairly elastic.

Films 13 and 14—China wood oil and rosin heated and thinned out. These are practically waterproof and stretch $2\frac{1}{2}$ times their own length.

Film 15—Linseed oil thickened by heat and mixed three parts of oil to one part of gasoline. It increased 6 per cent of its own weight after being in water 72 hours.

Film 16—Raw linseed oil. Submerged in water 72 hours and increased 16 per cent in weight. The film was very easily torn when full of water but when dried out, fairly elastic.

Films 13 and 14 will make a waterproof paint of considerable value if mixed with the proper pigments and used in a warm climate, but are easily broken when at a temperature below freezing point. Every film mentioned above was tested at 8 deg. above zero F. Films 13, 14, 6 and 7 were as brittle as glass. All the oil films were tough and pliable. Some of the films were baked at a temperature of 135 deg. F. Practically all the air-dried films absorbed a higher percentage of water than the baked films of the same material. This demonstrates that baking closes up the pores and binds the several coats together more than the air-drying method.

The committee does not advocate the use of as high a percentage of gasoline or other thinners as were used in some of these films, as they were prepared for demonstrative purposes only, but it is contended that a heat-treated oil containing a percentage of volatile oil sufficient to make it flow freely will give better protection to steel than an oil that absorbs a high percentage of water. The results of the tests on steel plate showed this result. Twelve steel plates were prepared, the first six of which were fastened on the interior of the outside channel of a tender frame. The tank under which they were placed was in good condition and comparatively little water came in contact with them. The other six were placed under a tender in the same position, whose tank leaked and subjected them freely to water and a heavy accumulation of dirt. The paint mixed with a treated oil gave the best results. The kind of paint used and the results from corrosion are given below:

Plate 1—A combination paint with carbon and oxide of iron base, ground in linseed oil—75 per cent corroded.

Plate 2—A combination paint, oxide of iron base—10 per cent corroded.

Plate 3—A combination paint but little different from No. 2—15 per cent corroded.

Plate 4—A combination oxide of iron and red lead pigment ground in linseed oil—20 per cent corroded.

Plate 5—Composition carbon paint ground in chemically treated linseed oil—10 per cent corroded.

Plate 6—Carbon ground in linseed oil—90 per cent corroded.

Plate 7—Red lead and lamp black mixed by hand with linseed oil, not ground—total failure.

Plate 8—Carbon ground in linseed oil—total failure.

Plate 9—A chemically treated combination paint, red lead base—5 per cent corroded. (Considering service, very excellent condition).

Plate 10—Primed with a liquid primer, on one half of the plate a second coat of carbon was applied. On the other half, same as primer. The latter half was a total failure. The portion second coated with carbon—75 per cent corroded.

Plate 11—Red lead base, combination paint ground in treated oil. Second coat, carbon base, combination pigment, ground in treated oil—very little corrosion. (Considering the service, a remarkably good paint.)

A third test was made with plates treated and painted with the same material as in the previous plate test. These plates were fastened on a coach roof and used every day as the second car of a train behind a coal-burning engine. They were exposed from October 17, 1914, until August 1, 1915, and were subjected to some very severe conditions. Here, as before, the treated oil plates were in much better condition than the others. In substantiation of these conclusions quotations were

read from a paper presented by Maximilian Toch, published in the June number of the Industrial and Engineering Chemistry, and also a quotation published in the same journal from Henry A. Gardner.

One thing that must be considered is that the treatment of linseed oil as it was used in the test will not pass an analysis for pure linseed oil, and until the chemist can find a standard for analyzing this class of material the actual service this material gives must be used as the most reliable test. The committee recommends the use of a solution of ordinary blue vitriol of 10 per cent strength for washing off galvanized iron surfaces, for the purpose of roughening up the surface of the iron sufficiently to give an anchorage for the paint. Apply the solution with a brush to the galvanized surface, let it remain until fairly dry, wash off with clean water and let surface dry thoroughly. The same effect may be produced by allowing the galvanized iron to weather for a year or more or by coating the surface with copper acetate. Another mixture which will give practically the same results is made as follows:

2 oz. copper chloride
2 oz. copper nitrate
2 oz. sal-ammoniac

Dissolve in one gallon water, apply with a brush, let stand until dry, wash off thoroughly with clean water and let dry. Dust off and apply paint.

The committee showed various specimens which had been tested during the past year, which with the information regarding the way in which the paint was prepared provided very valuable information for the association. The test committee consisted of J. W. Gibbons, chairman (A. T. & S. F.); J. McCarthy (G. T.), W. H. Dutton (L. V.) and W. A. Buchanan (D. L. & W.).

FLAT COLOR VERSUS ENAMEL COLOR

M. L. Shaffer (Penn.):—It has been thoroughly demonstrated by tests extending over many years that the advantages in the use of a properly prepared varnish color are much greater than might be expected. In car work it has been the aim of the painter to make as elastic a foundation as possible. After the color has been applied it is always desired to use a rubbing varnish possessing as much durability as possible, and, of course, elasticity and durability are the main requisites of a finishing varnish. Therefore, it seems reasonable that attention be paid to the elasticity of the color coat as well as to the elasticity of the priming, surfacing and clear varnish coat. The flat colors are made by grinding the pigments in Japan, which are generally very short, and contain shellac in large proportions. We are therefore interposing between our surfacing and varnish coats a very thin, brittle, non-elastic film or color when the flat colors are used. If, on the other hand, a color is applied that has been properly mixed with a rubbing varnish in the form of an enamel the general principle of elasticity is being carried through the entire operation of painting. This, as it appears, is theoretically sound. Experience has shown that this is borne out in practice with many other distinct practical advantages which may be briefly noted as follows: First, the color being ground in varnish can be applied heavier and consequently will, especially on repair work, tend to fill up and repair any slight imperfections on the surface. Second, the varnish color will hold out the succeeding varnish coats much better than will a flat color. By the use of a standard varnish color a coat of clear finishing varnish may be entirely eliminated, thus saving the railroad not only the cost of such a coat but the labor cost of application. Third, owing to the nature of the varnish used in making these enamels the color is more permanent and much less likely to fade. With the flat color, where Japans are used, the Japans are heavily loaded with so-called driers or oxidizing agents, which naturally have in time a harmful effect on the colors or pigments which are not chemically inert. A semi-gloss leaning toward the flat is recommended, as this would dry in from three to six hours, so that

there would be little loss of time in comparison with the old Japan colors.

J. B. Shuttleworth (B. & A.) also presented a brief paper on this subject, speaking strongly in favor of the enameled color rather than the old flat color, substantiating the claims made by Mr. Shaffer.

STEEL CAR DESIGN FROM A PROTECTION STANDPOINT

Two papers were presented on this subject, one by John B. Wright, of the Baltimore & Ohio, and George Warlick, of the Chicago, Rock Island & Pacific. Mr. Wright's paper is abstracted on page 525 in this issue. The following is an abstract of Mr. Warlick's paper: In the construction of steel cars the body should be as plain as possible. No countersunk rivets or butt joints should be used. The open corners should be eliminated as far as possible, as they will hold dust and moisture, ultimately causing corrosion. Sharp corners should also be eliminated, and the joints should be soldered inside and out. Better results would be obtained were the Gothic sash not used, and the deck should be plain, without projections that will hold the dust, cinders and moisture. The roofs should also be plain and made without the standing seams, and where the side and deck panels are used they should be bent in one piece. The arch type of roof has preference to the deck roof on steel equipment for this reason. Better results will be obtained if the interior of the steel car is finished in wood, as expansion and contraction on the steel finish cause the paint to crack.

Discussion.—The members spoke strongly in favor of the smooth steel sheets for passenger train cars, claiming that the extra first cost of these sheets will be fully warranted from the painting and maintenance standpoint. Some roads use aluminum doors with very great success, claiming that it is very difficult to prevent the corrosion on the inside of the steel doors. Other members also spoke strongly in favor of the canvas roof on steel equipment, and others spoke strongly against the use of screens which have been applied in many cases in the same manner as on wooden equipment. Mr. Hutchinson called attention to the stainless steel manufactured by the Firth-Sterling Steel Company, which might offer a solution to some of the difficulties experienced where excessive corrosion takes place.

PRICE VERSUS QUALITY IN BUYING PAINT STOCK

W. O. Quest (P. & L. E.):—In many instances the secret paint formulations which have been sold by reliable paint manufacturers and have proven to be of the first quality cannot be safely imitated, regardless of the claims of the imitator, whose usual effort is to make and sell his imitation at such a low price that it is almost irresistible to a close buyer. A large percentage of the successful and fast surfacing systems of to-day are the original productions of the railway car and locomotive paint shop, and, as a rule, such specialty paints are recognized for their merit and worth and not by the price they are sold for. Before the present financial depression the painter had little to complain of concerning the quality of the general paint material furnished to his department. With forced economies have come the competition of the cheap paint stock offered by makers who evidently have not the slightest knowledge of the requirements of the paint they are selling. This has forced the old established firms, selling the old railway special paints, to cut the prices of their goods, which it is believed, has forced them to reduce the quality of their goods. The practical man in charge of the paint shop knows that something new in the form of paint or varnish is at least dangerous until it has proven its worth. Mistakes in purchasing paint material can never be remedied without large expense if the mistakes are too pronounced, as it is necessary to extensively remove this paint with a chemical remover or the burning-off torch. The painter should be consulted when a change of the quality of the paint is contemplated.

The cheap non-opaque railway body color loaded with non-

opaque fine silica is one of the worst materials the railway paint shop man has to handle. If the body color is loaded with excessively inert material it will be necessary to apply extra coats of paint to produce the uniform color effect desired, and the color will also fade more readily than the pure pigment product. The cheap poorly ground Japan usually manifests itself through its solubility, which, if pronounced, prevents a smooth color effect through the subsequent coats.

The best known special roof paints and methods of application procurable at any price are not too good for the purpose for which they are used. It is a waste of time, labor and money for a railroad company to buy a cheap roof paint which has nothing to recommend it but its low selling price. The results obtained from a cheap varnish have been a little different. The reduction in price has been met by many of the old specialty railway varnish makers, and up to date we have been agreeably surprised by the results obtained from this varnish. The freight car paint is one of the most abused of commodities. Ninety per cent of the experiments with low-priced paint have proven unsatisfactory. The first-class protective paint must be formulated out of a first-class binding oil, an oil made in Japan and the best of oil-carrying pigments regardless of color. The price of a first-class freight car paint should not be excessive, but it should not be so low as to prevent its containing the proper grade of material, as it will not prove profitable.

INTERIOR FINISH OF STEEL PASSENGER CARS

J. C. H. Kunkel (Penn.) :—The steel must be perfectly free from rust, scale and acid. Apply a first-class primer, one that will maintain its elasticity for a long period, and have a tenacity that will prevent peeling and provide a foundation for the outer coats. Allow the primer 48 to 60 hours to dry, the longer the better. After the primer is dry, apply two or three coats of surfacer. It is important that the pigment be ground fine, as the protection of the steel is much greater if the particles are fine. Sand the surface with oil and No. 0 emery cloth. Two coats of straight color that have the same drying qualities as the intermediate coats is recommended. Straight color is preferable to graining or stippling, as the marred parts of the car can be repaired with far less expense and time. The color should be of a light tint, as it will not require a high finish, and will not show irregularities so prominently. After the body color has been applied, follow with three coats of varnish, one-half rubbing and one-half finishing, in order that a more elastic outer coating may be obtained. The above formula for varnish is far better than the straight rubbing, for the latter contains very little oil and is made more brittle by strong drier, and the intense moisture evaporating upon the varnished surface, tends to separate the gum from what little oil is in it, decreasing the wearing qualities still more.

The question arises right here whether too much trouble and too much expense and risk are not often involved to produce a temporary effect in finishing the interior of a car. Why not endeavor to work for the protection of the steel and durability of the painted surface, which will be practical and economical, and at the same time present a passable finish?

Discussion.—In the discussion on this subject several members stated that they had found it very difficult to make satisfactory repairs on the interior of the car where it was stippled or grained. For that reason the straight color finish is strongly favored, some members advocating the wood interior finish for that specific reason. However, as the steel equipment has not been in service sufficiently long no definite action was taken on this subject.

HANDLING PIECE WORK ACCOUNTS

Two papers were presented on this subject, one by H. Heffelfinger, of the Pennsylvania, and F. W. Bowers, of the Erie. Mr. Heffelfinger's paper is abstracted on page 526 in this issue. The following is an abstract of F. W. Bowers' remarks:

The auditing department, as a rule, prescribe the forms and

system of accounting for piece work systems, and the superintendent of piece work or his equivalent usually determines and supervises the rate making after obtaining data on the actual cost of the operations. As new operations develop they should be accurately timed and a fair piece work price made on a basis of a minimum cost of production over an hour or day rate. It should be just and fair and such that a skilled workman will be able to make, by increasing the amount of work he does, a higher rate of pay. The piece work checker, or the party that assumes the responsibility for the work after the completion of each operation, should be thoroughly acquainted and familiar with the mechanical part of the operation.

Discussion.—It was pointed out that local conditions must be taken into consideration when making piece work rates, and that when new rates were being established a trial price should be applied for a certain length of time to insure that it is fair to both the men and the company, and when the price is once accepted it should be maintained. It is not believed to be feasible to limit the pay of any workman, especially in rush times; if this is done the workman will automatically decrease his pace and not turn out as much work. On the Erie when improvements are made the prices are readjusted by conference. Mr. Gibbons, of the Santa Fe, explained the workings of the bonus system and its use on that road.

VARNISH TURNING WHITE

H. M. Butts (N. Y. C.) :—In order to obtain the most reliable information as to whether the roads are having any serious trouble with varnish turning white a letter of inquiry was sent to 19 different roads of the United States and Canada. Of the replies received only two were quoted as having any serious trouble, eight having very little and nine having no trouble at all. The varnishes used were of various makes of the ordinary commercial grade, ranging in price from \$1.75 to \$2.25 per gallon. The information received was very largely to the effect that dampness combined with very sudden changes in temperature would produce conditions which would cause the varnish to turn white. It was also shown that the cheaper grades of varnish do not recover their natural appearance as readily as do the better grades. On the whole, very little trouble is being experienced with varnish turning white with the ordinary makes of varnish used for railroad purposes.

Discussion.—The members concurred in the belief of Mr. Butts that there is no good reason for a first-class finishing varnish to turn white, although trouble has been experienced where a rubbing varnish has been applied as the finishing coat. The varnish on a locomotive tender should be allowed to be thoroughly dry before the water is placed in the tank.

MAINTENANCE OF ENAMEL COLOR VERSUS VARNISH FINISH

E. B. Stair (A. & W. P.) :—When considering an exterior finish or enamel or varnish color compared to the regular varnish finish it can be said that the former will not wear or clean as easily and economically as the latter. With the enamel or varnish color the same luster is not obtained as with the clear varnish of a good quality. Several years ago a body enamel Pullman color was used on the exterior of several coaches, and it was found that the working qualities of the product were such that it was anything but a pleasure to apply, and the appearance of the job was not as satisfactory as that obtained from the varnish finish. It also did not wear as well, nor did it clean as easily nor as cheaply as the varnish finished job. We had some postal cars finished on the interior with white enamel, and it proved to be more expensive to clean than varnish over the enamel, as the dirt penetrated into the enamel, requiring considerable rubbing to get it out.

J. W. Quarles (C. & O.) :—There is no question but that the varnish finish will give much better service as regards wear or durability, where the varnish is of a grade as good as the enamel or varnish color. The enamel or varnish color being

soft and easily cut will wear out more quickly with the friction of cleaning than will the varnish finish. Any color pigment or matter mixed with the varnish is certain to weaken the elasticity according to the strength of the coloring matter required to produce an opaque varnish color. If a low grade of varnish is to be used in finishing, the good grade of enamel or varnish color would be preferred on passenger equipment.

PROTECTING STEEL WITH PAINT

P. J. Burns, foreman painter at the Hoboken shops of the Pennsylvania, read a brief paper on this subject, an abstract of which follows:

The initial rusting of steel invariably commences on the sharp edges and minute projections existing on iron and steel surfaces, which proves that it is practically impossible to obtain a uniform protection when a brush is used in applying the paint. The lasting qualities of the "smalted" signs are well known. We have come to the conclusion that by substituting a very fine sawdust for the sand, using it in the same manner, and by painting over the sawdust we can secure a very much better metal protective coating. This might be carried further by having a coating of fresh paint with a substance that will completely cover the metal and fill up all the small holes and cracks, cover the rivets and in fact form a ground for the subsequent coating. There is a large variety of materials that may be used, such as abestine, cement or any inert pigment. The finishing coat can be made very heavy and applied freely so as to completely cover the material.

OTHER BUSINESS

Oscar P. Wilkins (N. & W.) recommended that standing committees be appointed to consider subjects such as passenger car roofs, proper treatment for locomotive tenders, and treatment of the interior of steel freight cars. By having five such committees with 10 or 12 members each, opinions from a greater percentage of the members will be obtained in the reports, to the ultimate advantage of the association.

T. J. Hutchinson (G. T.) revived the subject that was presented at the last year's convention regarding the lettering of freight cars. He called attention to the necessity of having legible and clearly defined letters and numerals, in order that the car foremen, inspectors and interchange men may more accurately record the numbers of the cars. He strongly recommended the use of the full face block or the Egyptian letter.

The following officers were elected for the ensuing year: President, H. Hengevelt, Atlantic Coast Line; first vice-president, John F. Gearhart, Pennsylvania; second vice-president, J. W. Gibbons, Atchison, Topeka & Santa Fe; secretary-treasurer, Albert T. Dane, Boston & Maine. The secretary reported a membership of 292. Wilmington, Del., received the largest number of votes for the next place of meeting.

ROTARY FOUR-WAY VALVE

BY E. H. WOLF

Air cylinders are extensively used about both car and locomotive repair shops to provide the necessary power for a variety of bending, straightening and forming operations. Frequently the air pressure is used in one direction only, but it is often desirable to move the piston in either direction, the air supply in such cases being usually controlled by two three-way valves, one for each end of the cylinder. The valve described herewith is designed to perform the functions of the two three-way valves with one operating handle and a three-position quadrant.

This valve is very simple and may be cheaply made. The only parts requiring finish are the valve and its seat, and for that reason they are the only parts shown in the drawing. They may be used with the cover, handle, key and washer from a Westinghouse type G-6 engineer's brake valve. The valve itself is a cast iron disk, 15/16 in. thick, upon the top of which are lugs

between which the handle key is placed. The face of the valve contains an exhaust cavity, and the supply port is an 11/16 in. hole extending through the disk. The valve seat contains three ports, one in the center leading to the atmosphere and the other two leading to the cylinder pipe connections. The valve is so placed on its seat that in its central position the supply port is located

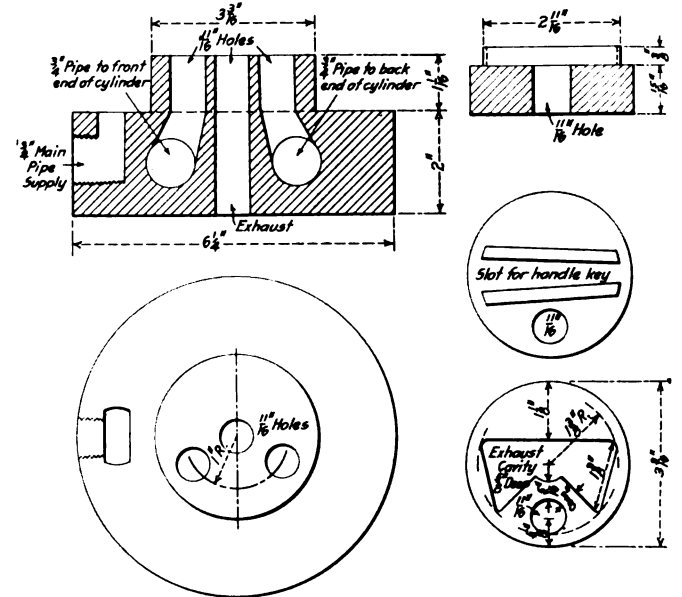

Four-Way Valve and Seat

between the two cylinder ports, both of which are located under the exhaust cavity and thus open to the atmosphere. By moving the handle from the central position in either direction the supply port is brought into register with one or the other of the cylinder ports, thus moving the piston in either direction desired. The valve may be used with cylinders up to 20 in. in diameter.

FLUE CUTTER

BY LOUIS LEBOVITZ

The drawing shows a simple device for cutting off flues at the smokebox end. It consists of a spindle 1 5/8 in. in diameter, at the end of which is a 1 in. square stem which may be inserted in the socket at the end of a flexible shaft. A 3/8-in. slot, 1 1/16 in.

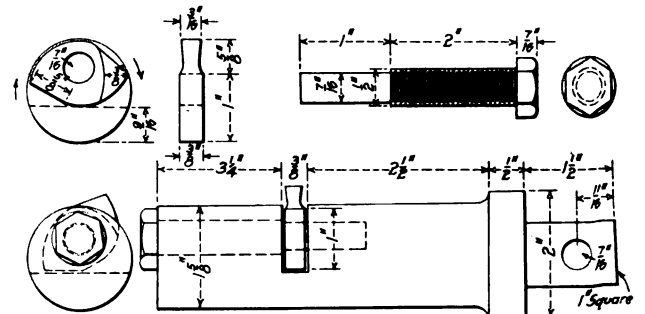

Simple Flue Cutter with Automatic Feed

deep, is cut in the spindle 3/4 in. from the end and a 1/2-in. hole is bored and tapped from the end of the spindle to the slot. Beyond the slot a 7/16-in. hole extends for a distance of about 5/8 in. A cutter of the form shown in the drawing is inserted in the slot and pivoted on the end of a special bolt threaded into the end of the spindle.

When inserted in a flue, the cutting edge of the blade projects slightly beyond the surface of the spindle. As soon as it engages the tube, however, it is gradually drawn out as the cutter revolves, thus automatically feeding into the tube. The bottom part of the cutter is so shaped that it forms a stop when in contact with the bottom of the slot in the spindle. When the tube is cut off, the motor may be reversed and the cutter withdrawn.

NEW DEVICES

BORING AND TURNING MILL

A boring and turning mill has recently been placed on the market by the Niles, Bement, Pond Co., 111 Broadway, New York, which has been especially designed to provide ease and convenience of manipulation by the operator. The machine is entirely self-contained, no parts extending below the floor line and it requires no special foundation. All changes of speed, the control of the rapid power traverse and hand adjustment of saddles and bars, the cross rail adjustment and table control are within easy reach of the operator's position. One lever disengages the feed, engages the fine and coarse feeds and operates the rapid traverse in either direction.

The housings are of the box girder form without openings in the front face. They are securely bolted to the bed of the machine and are firmly tied together at the top by a cross brace of deep section. The cross rail elevating screws are located be-

power adjustment. The saddles are provided with taper gibs and may be clamped in position when the bar is feeding.

The machine may be either direct or alternating current motor driven or belt driven. For direct current it is equipped with a motor of 4 to 1 speed variation, carried on a drive plate between the housings back of the table bed. Power is transmitted through a double run of clutch gears which provide two mechanical changes in speed. With the usual 16 speeds in the controller 32 speeds are thus available at the table. The motor is fitted with push-button control and a dynamic brake for the table. The cross rail is elevated by means of a separate motor located on the housing cross brace. This motor also furnishes power for the rapid traverse of the bars and saddles. When belt or alternating current motor driven the drive is transmitted through a speed box and back gear located at the rear of the mill, which gives 12 changes of speed. A separate motor is furnished with alternating current drive for operating the cross rail and traversing the bars and saddle.

This type of machine is made in sizes which swing from 44½ in. to 74½ in., the diameter of the table ranging from 42 in. to 68 in. The driving motor horsepower required varies from 7½ for the small size machine to 12½ for the largest size.

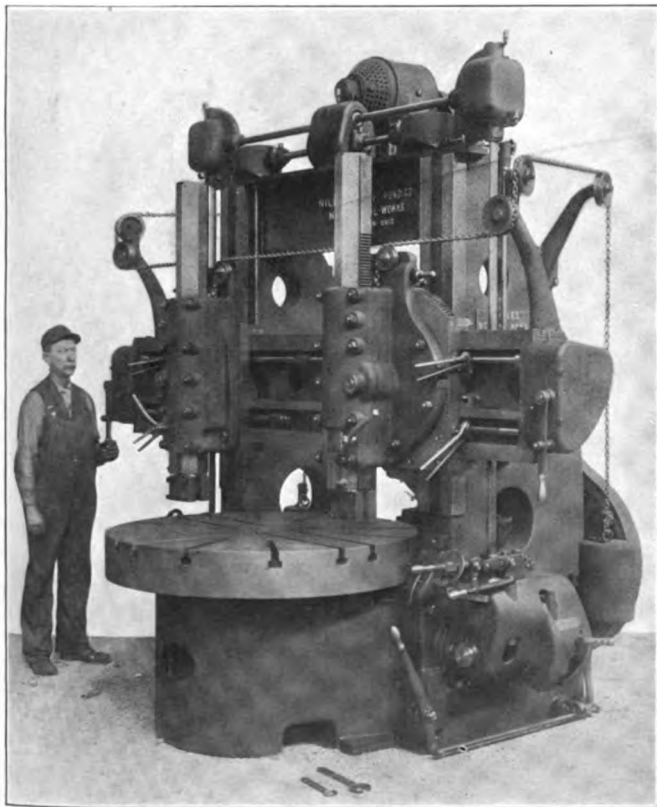

Niles Boring and Turning Mill

tween the housings. The table is supported by an annular bearing of large diameter running in a bath of oil. It is driven by a coarse pitch bevel gear of maximum diameter and wide space. The table spindle is long and of large diameter. It is maintained in alignment by an upper and lower bearing, the former being bored out of the solid bed and fitted with an adjustable taper bush to take up the wear. On the end of the spindle is an adjustable threaded collar to prevent lifting of the table.

The cross rail is of the three-track type, having a narrow guide at the bottom, with the saddle traversing screw located between the guiding surfaces. It is of the box girder form with a broad face and of great depth to withstand heavy cutting. It may readily be clamped to the housing and is provided with a

BELT SHIFTER

The Dearborn Steel & Iron Company, Chicago, Ill., has recently placed on the market a device called the Diamond Speed Shifter, which is used for shifting the belt on any step cone belt-driven machine.

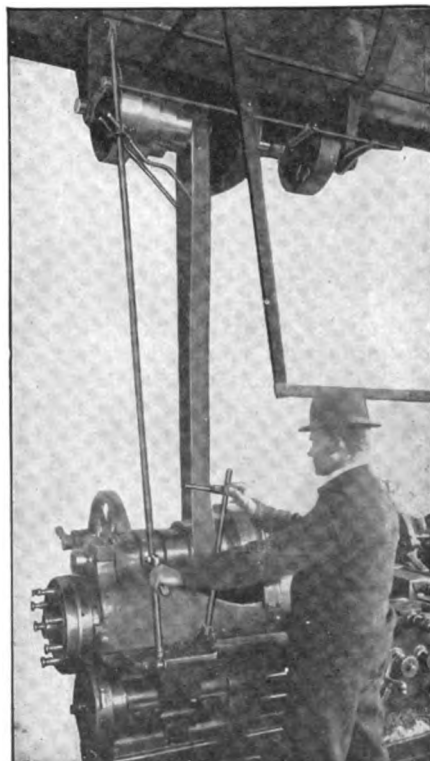

Belt Shifter for Step Cone Machines

As will be noticed from the illustration, the arrangement consists of two rods, one for shifting the belt to the different steps of the cone pulley on the jack shaft, and the other for shifting the belt on the cone pulley on the machine. The former consists of a rod having a ball and socket connection on the bed of the machine, the other end being fixed to the rafters from which the jack shaft is hung. Near the top of this rod an iron loop is attached, the loop passing around the belt in such position that as the rod is twisted the belt will be moved from one step to the next very readily. The arrangement for shifting

the belt on the lower cone is easily understood from the illustration.

This device presents a simple and safe way of shifting the

belt. No poles are necessary, nor is any hand work required on the belt, with the elimination of the attendant danger to the employee. It provides an ever-ready means for obtaining quickly the correct speed, thus making it easier for the workman to use the proper speed for his work. It can be operated with as much facility as is the modern gear-headed machine and brings the belt-driven machines within that category.

HIGH SPEED HACK SAW MACHINE

A heavily built high speed hack saw machine has recently been developed by the Massachusetts Saw Works, Springfield, Mass., in the design of which special care has been taken to insure rigidity and perfect alinement of the working parts. It

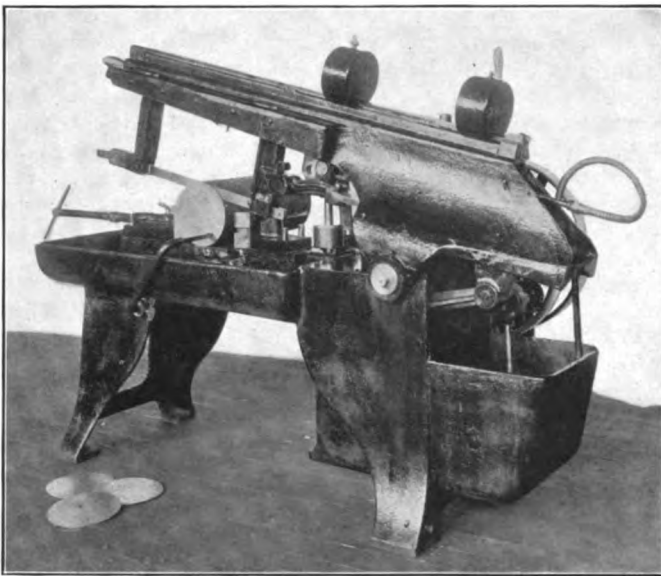

High Speed Hack Saw

is equipped with a number of special appliances, the purpose of which is to provide smoothness of action when starting and finishing the cut, thus removing the cause of many broken saw blades.

The machine is set low on a solid foundation with wide spread legs to give maximum rigidity. Around the bed is a large pan for cooling compound, and under the bed at the rear is an easily accessible nine-gallon tank fitted with screens to protect the pump from chips. The base, including the tank and pan, is one casting. The power head of the machine, which carries all working parts, is pivoted on the driving shaft center, thus simplifying the construction and providing for the full length stroke of the blade with the head at any angle.

The machine is intended to be driven directly from the line shaft, and two line shaft pulleys are recommended, the diameters to be proportioned to provide cutting speeds of 65 and 130 strokes per min., respectively. The change of speed is controlled by means of a lever and clutch, which may be engaged with either of two pulleys on the driving shaft of the machine. The blade is drawn instead of being pushed through the work, thus eliminating the springing action of the frame and resulting in a steadier motion to the blade under strain. The saw frame will take any blade from 12 in. to 17 in. in length, and may be quickly adjusted to any length desired. The frame bearings in the head are three-point slide bearings, of ample width provided with gib adjustment to compensate for wear. This feature, together with the flat clamps on the saw frame posts, insures perfect blade alinement and a straight cut.

A lever controlled oil dash pot cushions the descent of the blade when it is dropped onto the work and prevents shock when the cut is completed. The blade thus gently engages the

material regardless of the point from which the frame is started, without danger of breaking or stripping the teeth. An automatic patent lift and a knock-off, which operates silently and positively, are also among the special features of the machine which tend to bring about an increase in the life of the saw blades.

The vise is equipped with patent swiveled jaws. The rear jaw may be set at any angle up to 45 deg., in either direction, and the front or sliding jaw is self-adjusting, accommodating itself to the angle of the fixed jaw, or to any irregularity in the surface of the work.

The machine is designed to cut stock up to 9 in. square. For annealed and hard tool steel and steel castings the lower speed should be used, with a cooling solution. For cast iron the same speed is used, but the machine may be run without solution, while on soft machinery steel and wrought iron the solution is used with the higher speed. The pulleys are 16 in. in diameter, and take 3 in. belts.

COLLAPSIBLE TAP

A collapsible tap designed to meet all requirements of internal threaded work has been developed by the Modern Tool Company, Erie, Pa. The device is simple in construction, consist-

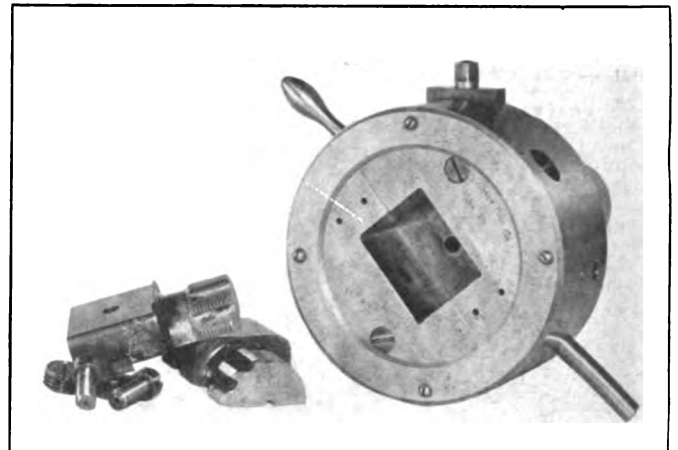

Collapsible Tap with Chasers Removed

ing of as few parts as possible and is not easily disarranged when put into operation. It is built to have as great an amount of rigidity as the solid tap, thereby eliminating any tendency for the chasers to spring and cause taper threads.

The construction of the tap is shown in the drawing and one

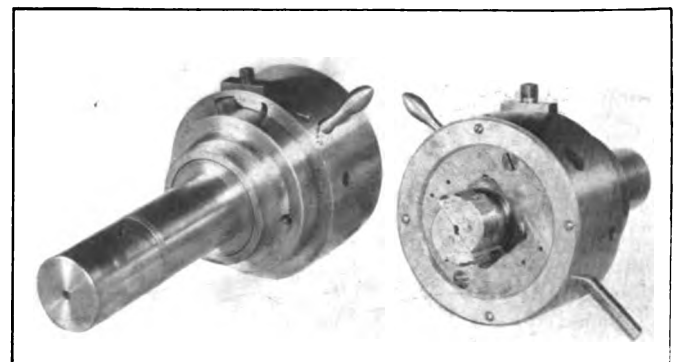

Modern Collapsible Tap

of the photographs. The tap chasers consist of two sliding pieces (105) which are a push fit in the chaser blocks (104), in which they are locked by means of two machine screws. The two chaser blocks slide in the tap head (103). The tap head

slides into the shank head (106) and is held in position by two driving studs (142); the shank head is locked solid with the shank (107). A cam ring (102) is provided outside the tap and shank heads. This ring contains two cam rises which control the position of the chaser blocks, the latter being held tightly against the cam ring by means of two springs (118).

In operation the shank is clamped in the turret of the ma-

chine and the stop on the turret set for the length of thread desired. The tap is then run up against the work, which revolves in the spindle of the machine and is fed into the work to conform to the pitch of the thread being tapped, until the stop on the turret is struck. Then the collapsible tap feeds out until the locking feather (111) releases the cam ring, which revolves and allows the two chaser blocks to slide in opposite directions, thereby collapsing the tap. After the tap has been pulled out of the threaded piece it is set for the next piece by means of the handle shown on the cam ring.

These valves, known as the Simplate inlet and discharge valves, are shown in the illustrations. By referring to the drawing of the discharge valve it will be seen that the device consists of a valve seat *A*, a valve keeper *B*, three flat plate ring valves *C* concentrically arranged, and the volute springs *D*, which

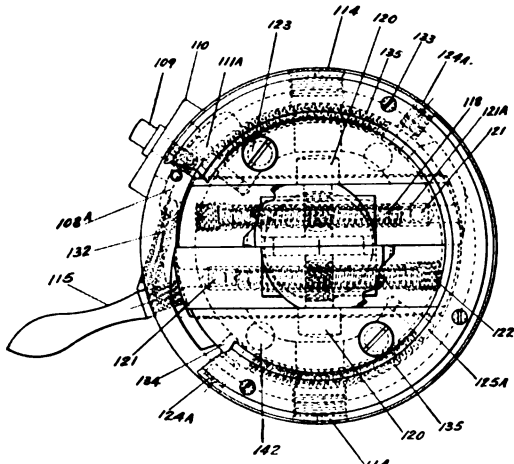

Details of Modern Collapsible Tap

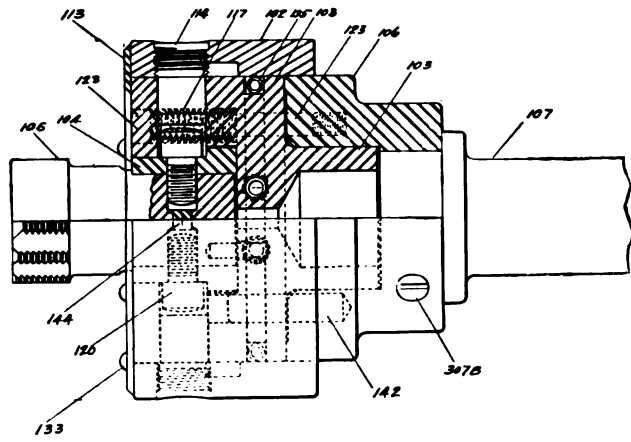

chine and the stop on the turret set for the length of thread desired. The tap is then run up against the work, which revolves in the spindle of the machine and is fed into the work to conform to the pitch of the thread being tapped, until the stop on the turret is struck. Then the collapsible tap feeds out until the locking feather (111) releases the cam ring, which revolves and allows the two chaser blocks to slide in opposite directions, thereby collapsing the tap. After the tap has been pulled out of the threaded piece it is set for the next piece by means of the handle shown on the cam ring.

This tap may be applied to hand screw machines, automatic screw machines and other types of machine where the tap is stationary and the work revolves. It may also be applied to machines where the spindle holding the tap revolves and the work is stationary, such as drill presses, by attaching a device for closing the collapsible tap automatically as it revolves.

This tap may be secured in four sizes, which have a total range from 1/2 in. to 3 in. The chasers are changed by removing the two chaser screws. The chasers may be ground either on the lips or on the throats the same as solid taps so that it is possible to keep as short a throat as necessary when cutting close to a shoulder.

hold the valves in position against the seat. The valve seat and keeper are held together by a special steel bolt, with a countersunk head, and a castle nut. The construction of both inlet and discharge valves is similar in detail, but they are not interchangeable, since the bolt in the discharge valve is first passed through the valve seat, while in the inlet valve it is first passed through the valve keeper. In the latter valve the valve keeper is much thinner than in the discharge valve. These differences make it impossible to inadvertently interchange the two valves, which are not meant to work interchangeably.

The inlet valve is so adjusted that the outer plate opens with a pressure of but one-quarter ounce per square inch, and

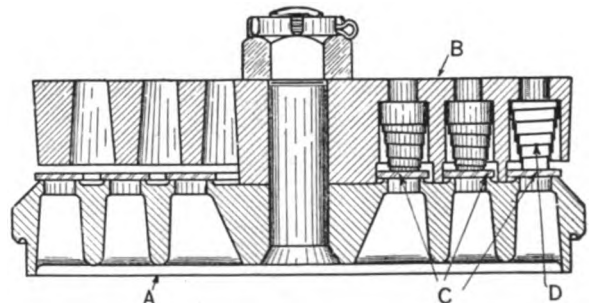

Flat Plate Discharge Valve of Three Separate Concentric Rings

FLAT PLATE AIR COMPRESSOR VALVES

During the last few years several designs of flat plate compressor valves have been brought out, none of which have proved entirely satisfactory. The valves shown herewith, al-

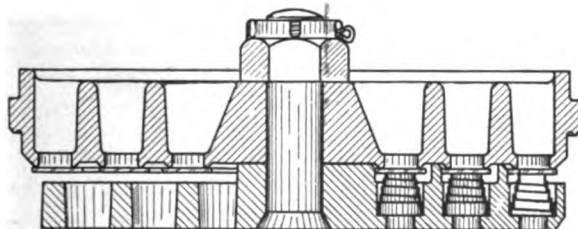

The Inlet Valve

though of the flat plate type, differ considerably from those which have been previously presented, the principal feature of their construction being the use of three separate plate rings of uniform section, each of which is controlled by its own but one ounce per square inch is required to open the intermediate plate. The inner plate requires a pressure of two and one-half ounces per square inch to cause it to open. The operation of the valve will thus be readily understood. At slow speeds only the outer plate will open, but as the speed increases and the volume of air to be handled becomes greater the intermediate plate will be opened, and finally for maximum performance all three plates will be in operation simultaneously. The valve plates are made of a special alloy steel, heat treated, straightened and ground true on one side only.

The Simplate valves are the product of the Chicago Pneumatic Tool Company, Chicago, and are claimed to be much more efficient, both mechanically and volumetrically, than the old type poppet valve. With these valves the construction of the cylinders is simplified, due to the absence of intricate valve operating mechanism, and the valves require no lubrication. They are said to operate with very little noise, and the con-

though of the flat plate type, differ considerably from those which have been previously presented, the principal feature of their construction being the use of three separate plate rings of uniform section, each of which is controlled by its own

struction of the valve seat and valve keeper is such as to offer the minimum restriction to the flow of air from the valve.

ADJUSTABLE CAR STEP

An adjustable bottom step for passenger coaches has recently been developed and patented by James H. Vaughan, Mobile, Ala. The device is a simple one and is easily manipulated from the

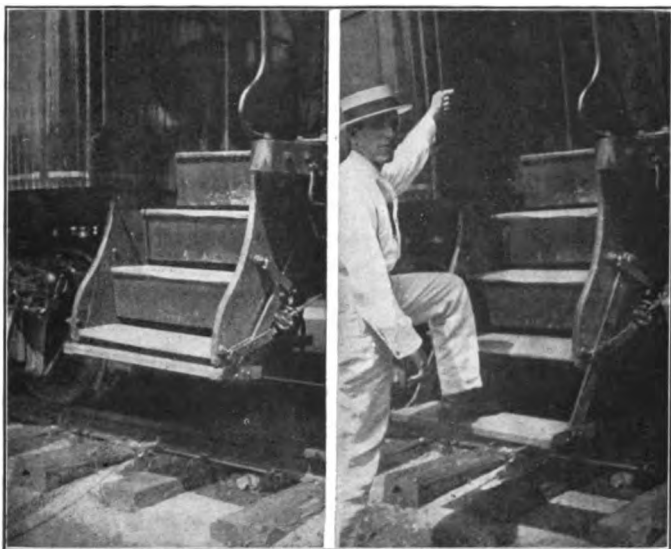

Adjustable Step in Raised and Lowered Positions

platform or vestibule of the coach. It is intended to supplant the stool or box which is now generally used at low station platforms.

The adjustable step is designed for attachment to the regular car steps and is placed below the bottom tread. It is operated by a lever placed on the end of the platform, a horizontal shaft is attached to the back side of the steps, arms at its ends connecting with the upper ends of the rods or side pieces which support the tread of the adjustable step. An arm on the shaft is connected with the lower end of the operating lever by a reach rod. When not in use the adjustable tread is raised to a point immediately below the bottom tread of the car steps. Its movement is directed by guides on the side of the car steps and is limited by stops when in its lower position.

AUTOMATIC ADJUSTABLE DRIVING BOX WEDGE

A driving box wedge, designed to automatically take up the wear between the driving box and the wedge, has been placed on the market by the Franklin Railway Supply Company, New York. The device is intended to effect a material saving in labor in the roundhouse by its feature of automatic adjustment, and is also claimed to considerably increase the life of the locomotive by eliminating shocks due to stuck boxes and loose wedges with their destructive action on crown brasses and rod bushings.

The adjustable wedge consists of two parts, an adjusting and a floating wedge. The adjusting wedge is tapered on one side to conform to the taper of the jaw and on the other side to conform to the lesser taper of the floating wedge. The latter fits between the adjusting wedge and the driving box, the thin end being at the bottom. It is made one-quarter inch less in length than the distance between the top of the binder and the top of the jaw. The adjusting wedge is attached in the usual manner to a wedge bolt which passes down through the binder and a spring bracket secured to the lower side of the binder. A coil

spring resting on the bracket supports the adjusting wedge by means of an adjustable collar on the wedge bolt. The tension of the spring keeps the adjusting wedge up in position, automatically taking up the slack due to wear.

In applying the wedge all surfaces are smeared with pin grease. Provision is made for the continuous lubrication of the faces of the floating wedge from the oil pocket in the top of the driving box. A cavity near the top carries oil through the wedge and distributes it over the surface bearing on the adjusting wedge.

The feature of especial importance in the operation of this device is the floating wedge and double-tapered adjusting wedge. The clearance at the top and bottom of the floating wedge allows it to move up and down slightly with the movement of

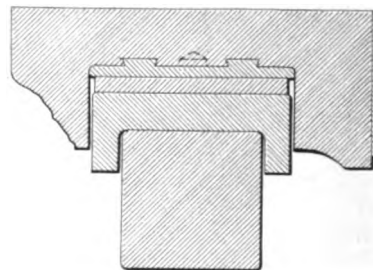

Section A-B.

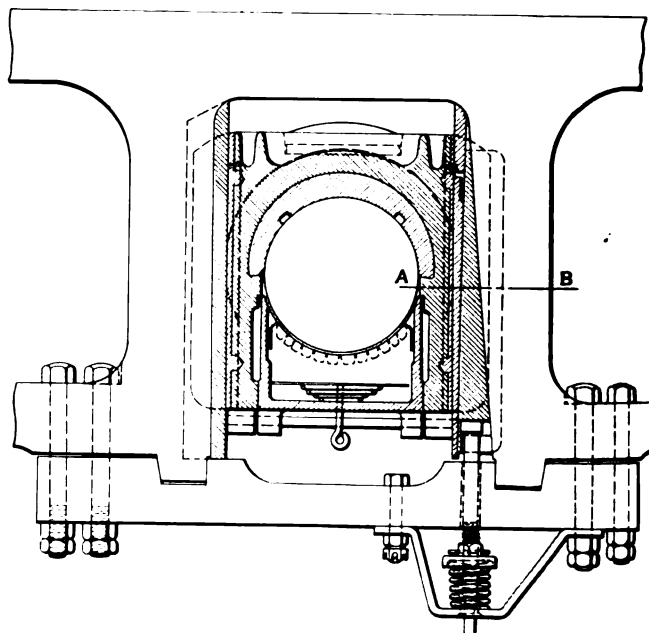

Franklin Automatic Adjustable Wedge

the box, thus eliminating all danger of the seizing of the wedge and box surfaces. Tests of the device have been made in service on a number of railroads, and the results are said to have been satisfactory in every case. Locomotives equipped with the adjustable wedge have run from shopping to shopping without the necessity of replacing rod bushings and without attention to the shoes and wedges.

BRICQUETTING IN CANADA.—Peat and chalk are being extensively used, it is reported, for briquetting in Canada. The peat is mixed with coal breeze and then pressed into briquettes. Such fuel has been found efficient and economical. Chalk also, of which there are large deposits in Canada, can be converted into a profitable fuel. If the chalk is pulverized and then combined with a certain percentage of breeze and solidified tar, the mixture being compressed into small briquettes or pebbles about the size of an egg, the briquettes burn with perfect satisfaction. The fuel has the advantage of being smokeless, has a high calorific value, and burns freely.—*The Engineer.*

RIVETING MACHINE

A number of riveters of the type shown in the accompanying illustration have recently been placed in service by the Hanna Engineering Works, 2059 Elston avenue, Chicago. This type of riveter is designed for car construction work and the feature of especial interest is the removable forged steel stake. This may be shaped to any form best suited to the work on which it is to be

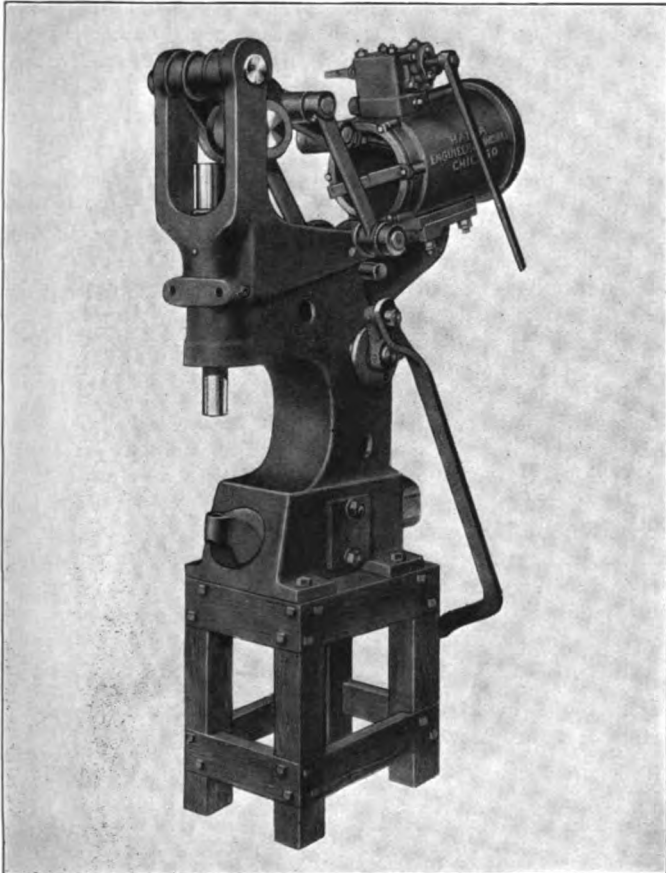

Hanna Riveter

used. It is particularly adapted to truck and similar work of close dimensions and may be arranged for either portable or stationary use.

The operating mechanism is of the well known Hanna type, which is designed to exert a predetermined pressure with every stroke.

SET-SCREWS AS RIVET SETS.—A cup-pointed set-screw makes a very fair substitute for a rivet set in case of a hurry job when all the regular tools are not available.—*American Machinist.*

SHIP CONSTRUCTION IN THE UNITED STATES.—United States shipyards had under construction or contract at the beginning of the fiscal year July 1, 1915, according to data obtained by the Bureau of Navigation, Department of Commerce, 65 steel merchant vessels of 298,426 gross tons. This is the largest amount of work at the corresponding time since July 1, 1907, when 134 such vessels of 403,473 gross tons were building or contracted for. On the seaboard, however, the steel merchant construction, 60 vessels of 288,701 gross tons, is greater than in any previous year, the nearest being 63 of 273,865 tons in July, 1901. Of the vessels now building, 21 are bulk oil carriers of 154,056 gross tons, 6 colliers of 25,475 gross tons and 5 passenger steamers of 17,000 tons, the rest being cargo boats.—*Iron Age.*

SAFETY WRECKER YOKE

The illustrations show a simple wrecker yoke developed by J. W. Riley, Sayre, Pa., which has not only proven a convenient appliance for the use of the wrecking crew, but has re-

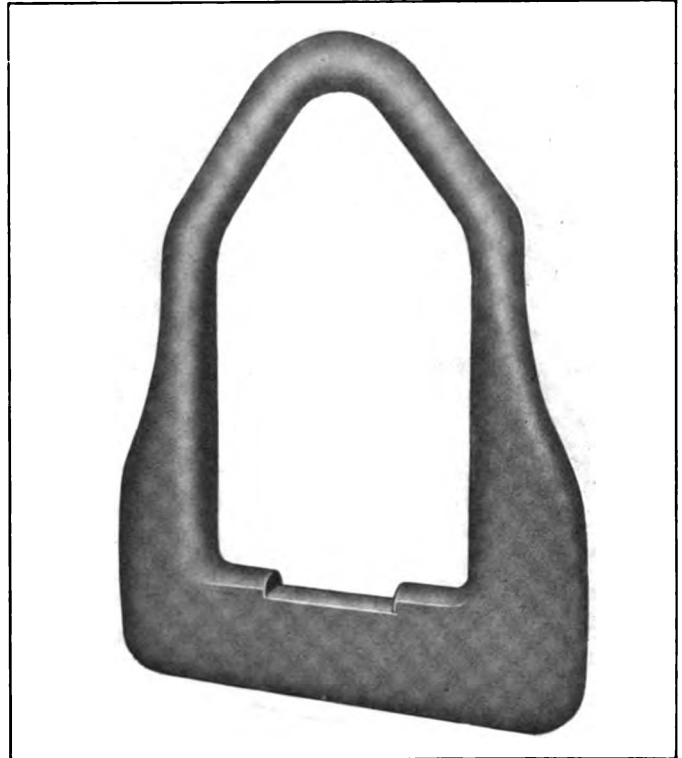

Riley Safety Wrecker Yoke

sulted in the prevention of chain breakages as well. The yoke is a solid steel casting weighing about 185 lb., and is designed to lift the heaviest loaded steel cars. It is intended to replace chains for attaching the crane hook to the car or other ob-

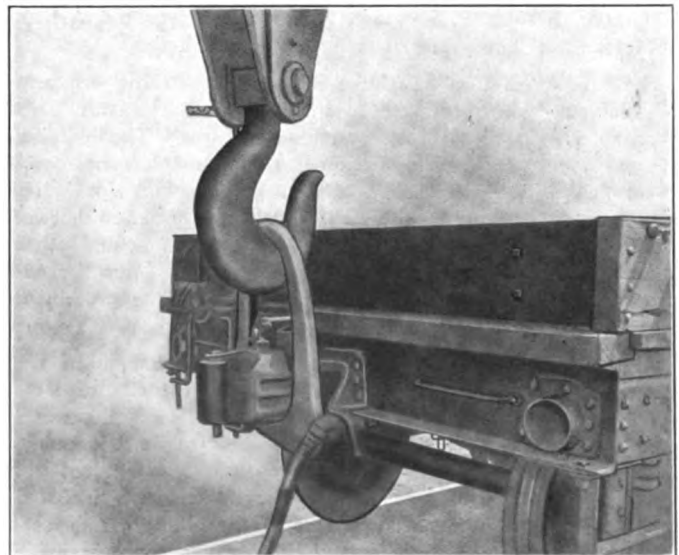

Wrecker Yoke In Operation

struction to be lifted where suitable projections are to be found. One of the illustrations shows the method of using the device to lift the end of a car by the coupler shank. A considerable saving of time is effected where this device replaces chains, and an increase in safety is also effected. It is now in use on a number of railroads in various parts of the country.

NEWS DEPARTMENT

The Rock Island Lines have made arrangements with the Railway Educational Bureau, of Omaha, Neb., to extend the privileges of the bureau to Rock Island employees.

The locomotive forces at the Terre Haute, Ind., shops of the Vandalia have been working on full time—54 hours per week—since the first of the month. The men in the car department have been working on this basis for some time.

Numerous facts which are of interest in connection with the movement to secure South American trade for industries in this country have been made the subject of a letter which the Pennsylvania Railroad has sent to the boards of trade of 70 cities and towns along its lines.

The stockton division, the Shasta division and the Sacramento shops have been awarded the 1915 safety banners awarded annually by the Southern Pacific Company for the greatest progress shown during the fiscal year in the furtherance of "safety first" work on the company's Pacific system.

The locomotive and car shops built by the National Transcontinental Railway Commission at Transcona, Man., and heretofore operated by the Grand Trunk Pacific, have been taken over with the National Transcontinental line east of Winnipeg for operation as part of the Canadian Government Railways.

Between Broad street, Philadelphia, and Paoli, 20 miles, the Pennsylvania Railroad is now running a few trains by electric power. The equipment of this section of the road for electric traction has been going on for about two years, and the expenditures have amounted to about \$4,000,000. Current is supplied by the Philadelphia Electric Company.

The members of the Russian Imperial Railways Commission, who have been in this country for some time on business for the government-owned railways of Russia, are this week making a tour over the main line of the Pennsylvania Railroad. The commission is composed of Count S. I. Schulenburg, president; Max N. Groten, Nicolas P. Kemmer, Alphons I. Lipetz and Arkadi S. Martynoff. The principal stop will be at Altoona.

The building of the "Salt Lake Route-Union Pacific" route at the Panama-California Exposition at San Diego has been awarded a gold medal for its unique features. The building was put up to provide information to world travelers and comfort to exposition visitors. It contains a rest room for ladies and children, with a maid in attendance, information bureau and telephone booths, smoking room for gentlemen and other accommodations. The special rest room provided for the entertainment of visiting railroad men is one of the prominent features.

The Lehigh Valley Railroad, following the example of the authorities of the Pennsylvania Railroad and the city of New York, has made a thorough physical examination of all persons having to do with the preparation or serving of food in public places—that is, of all dining car employees. One hundred per cent was the condition reported. The examination included also the workers in the headquarters of the dining car department at Easton, Pa. The company had its own surgeons make the examination, and a strict standard, including personal cleanliness, was adhered to. These examinations will be made periodically.

Employees of various divisions of the Grand Trunk system are forming associations for the organization of systematic and permanent methods of contribution for war purposes. The Grand Trunk Patriotic Association of Toronto has been or-

ganized with the following officers: President, H. E. Whittemberger; chairman, G. E. Pepall; vice-chairman, W. S. Wilson; secretary, J. A. Murphy, and treasurer, J. Gray. The Barrie Division Railwaymen's Patriotic Association has also been formed, with P. J. Lynch as chairman. Subcommittees will be arranged to establish a system of monthly collections until the end of the war, the amounts realized being expended on such articles from time to time as are decided to be desirable.

To show the magnitude of automobile traffic on Long Island General Manager McCrea, of the Long Island Railroad, has had a count made of the motor cars driven across his tracks. On Sunday, August 8, at the Merrick Road crossing, in Springfield, 9,408 automobiles passed between midnight and midnight. Of these 4,245 were eastbound and 5,163 westbound. At the Barnum Island road crossing, on the Long Beach branch, 4,739 cars passed in the same period, of which 2,620 were eastbound and 2,119 westbound. In the single hour from 11 a. m. to noon on Sunday, 845 motor cars passed over the Merrick road crossing. This is at the rate of more than 14 cars a minute, or about one every four seconds. Nearly all of these cars must have crossed the Long Island tracks at other points, not once but several times. The road has been authorized by the supervisors of Nassau county to install at certain points traffic posts similar to those used by the New York City traffic squad, to serve as route indicators for motorists.

CAR AND LOCOMOTIVE ORDERS IN SEPTEMBER

During the month of September, orders for locomotives, freight cars and passenger cars were reported as follows:

	Locomotives	Freight Cars	Passenger Cars
Domestic	157	5,495	61
Foreign	47
Total	204	5,495	61

Among the more important orders for locomotives were the following: Chicago, St. Paul, Minneapolis & Omaha, 4 Pacific and 6 Mikado type locomotives, American Locomotive Company; the Texas & Pacific, 7 Santa Fe type and 6 switching locomotives, Baldwin Locomotive Works; the Servian Government, 15 Prairie type locomotives, American Locomotive Company; the Philadelphia & Reading, 20 Mikado type locomotives, Baldwin Locomotive Works; the Madrid, Saragossa & Alicante Railway of Spain, 25 12-wheel locomotives, American Locomotive Company; the Norfolk & Western, 30 Mallet type locomotives, American Locomotive Company; the Erie, 33 Santa Fe type locomotives, 18 to American Locomotive Company, 10 to Baldwin Locomotive Works and 5 to Lima Locomotive Corporation, and the Chicago & North Western, 12 Pacific type, 12 Mikado type, 10 switching and one narrow-gage locomotive, American Locomotive Company.

Among the more important freight car orders were the following: The Erie, 300 gondola cars, Standard Steel Car Company; the Atchison, Topeka & Santa Fe, 500 stock cars, Pullman Company; the Chicago & North Western, 500 ore cars, American Car & Foundry Company; the Western Maryland, 200 automobile cars, Western Steel Car & Foundry Company, and 650 gondola cars, Standard Steel Car Company, and the New York Central, 1,000 freight cars each from the Standard Steel Car Company and the Pressed Steel Car Company for the Pittsburgh & Lake Erie and 500 box cars from American Car & Foundry Company for the Cincinnati Northern.

The two largest orders for passenger cars were those of the

Central of New Jersey, which ordered 25 coaches and 5 baggage cars from the Harlan & Hollingsworth Corporation, and the Delaware & Hudson, which ordered 9 coaches and 6 baggage cars from the American Car & Foundry Company and 9 coaches from the Barney & Smith Car Company.

MEETINGS AND CONVENTIONS

Engineers' Society of Western Pennsylvania.—At the regular bimonthly meeting of the mechanical section of the Engineers' Society of Western Pennsylvania, to be held in the society rooms in the Oliver building, Pittsburgh, on October 5, will be presented a symposium on gas welding and cutting. Papers will be presented by C. K. Bryce, engineer of the Oxweld Acetylene Company, Newark, N. J., on "Use in Welding Heavy Parts;" by J. B. Henry, general superintendent of the Union Steel Casting Company, Pittsburgh, Pa., on "Use in Steel Foundries," and by A. F. Mitchell, assistant to superintendent of the armor plate department of the Carnegie Steel Company at Homestead, on "Use in Steel Mills."

The thirty-fourth annual convention of the American Electric Railway Association will be held in San Francisco, Cal., from October 4 to 8. Simultaneously there will also be held the annual conventions of the American Electric Railway Accountants' Association, the American Electric Railway Engineering Association, the American Electric Railway Claims Association, the American Electric Railway Transportation and Traffic Association and the American Electric Railway Manufacturers' Association.

The following list gives names of secretaries, dates of next or regular meetings and places of meeting of mechanical associations:

- AIR BRAKE ASSOCIATION.—F. M. Nellis, 53 State St., Boston, Mass.
- AMERICAN RAILROAD MASTER TINNERS, COPPERSMITHS AND PIPEFITTERS' ASSOCIATION.—W. E. Jones, C. & N. W., 3814 Fulton St., Chicago.
- AMERICAN RAILWAY MASTER MECHANICS' ASSOCIATION.—J. W. Taylor, Karpen Building, Chicago.
- AMERICAN RAILWAY TOOL FOREMEN'S ASSOCIATION.—Owen D. Kinsey, Illinois Central, Chicago.
- AMERICAN SOCIETY FOR TESTING MATERIALS.—Prof. E. Marburg, University of Pennsylvania, Philadelphia, Pa.
- AMERICAN SOCIETY OF MECHANICAL ENGINEERS.—Calvin W. Rice, 29 W. Thirty-ninth St., New York. Annual meeting, December 7-10, 1915, New York.
- ASSOCIATION OF RAILWAY ELECTRICAL ENGINEERS.—Joseph A. Andreucetti, C. & N. W., Room 411, C. & N. W. Station, Chicago. Annual meeting October, 1915.
- CAR FOREMEN'S ASSOCIATION OF CHICAGO.—Aron Kline, 841 North Fifthth Court, Chicago. Second Monday in month, except July and August, Lytton Building, Chicago.
- CHIEF INTERCHANGE CAR INSPECTORS' AND CAR FOREMAN'S ASSOCIATION.—S. Skidmore, 946 Richmond St., Cincinnati, Ohio.
- INTERNATIONAL RAILWAY FUEL ASSOCIATION.—C. G. Hall, 922 McCormick Building, Chicago.
- INTERNATIONAL RAILWAY GENERAL FOREMEN'S ASSOCIATION.—William Hall, 1126 W. Broadway, Winona, Minn.
- INTERNATIONAL RAILROAD MASTER BLACKSMITHS' ASSOCIATION.—A. L. Woodworth, Lima, Ohio.
- MASTER BOILER MAKERS' ASSOCIATION.—Henry D. Vought, 95 Liberty St., New York.
- MASTER CAR BUILDERS' ASSOCIATION.—J. W. Taylor, Karpen Building, Chicago.
- MASTER CAR AND LOCOMOTIVE PAINTERS' ASSOCIATION OF U. S. AND CANADA.—A. P. Dane, B. & M., Reading, Mass.
- NIAGARA FRONTIER CAR MEN'S ASSOCIATION.—E. Frankenberger, 623 Brisbane Building, Buffalo, N. Y. Meetings monthly.
- RAILWAY STOREKEEPERS' ASSOCIATION.—J. P. Murphy, Box C, Collinwood, Ohio.
- TRAVELING ENGINEERS' ASSOCIATION.—W. O. Thompson, N. Y. C. R. R., East Buffalo, N. Y.

PERSONALS

It is our desire to make these columns cover as completely as possible all the changes that take place in the mechanical departments of the railways of this country, and we shall greatly appreciate any assistance that our readers may give us in helping to bring this about.

GENERAL

P. E. BAST has been appointed general fuel inspector of the Delaware & Hudson, with headquarters at Watervliet, N. Y.

W. M. SCHMALZREID has been appointed general inspector of passenger and freight cars for the Texas & Pacific at Marshall, Tex.

F. W. BOARDMAN has been appointed assistant to the mechanical superintendent of the Texas & Pacific at Marshall, Tex.

W. W. WARNER, general foreman of the Erie car repair shops at Marion, Ohio, has been promoted to the general foremanship of the steel car repair shops at Cleveland, Ohio.

W. H. OWENS, master mechanic of the Southern Railway at South Richmond, Va., has been appointed mechanical member of the valuation department of the Southern Railway.

F. O. HAYMOND, superintendent of the Bingham & Garfield Co., with headquarters at Magna, Utah, has been appointed also assistant superintendent of motive power and car departments.

H. J. WHITE, formerly general foreman, car department, Quebec grand division of the Canadian Northern at Joliette, Que., has been appointed supervisor of car work on all lines east of Port Arthur, Ont., with office at Toronto, Ont.

E. J. HARRIS, master mechanic of the Chicago, Rock Island & Pacific at Trenton, Mo., has been appointed acting mechanical superintendent of the Second district with headquarters at Topeka, Kan., succeeding G. W. Lillie, resigned.

WILLIAM C. SMITH, who was appointed assistant mechanical superintendent of the Missouri Pacific-St. Louis, Iron Mountain & Southern on September 1, was born on September 25, 1869, in Michigan. He was educated in the common schools and entered railway service on December 7, 1887. From that time until April, 1895, he served as machinist apprentice and machinist on the Missouri Pacific Railway; from April to November, 1895, he was a machinist on the Atchison, Topeka & Santa Fe; from November, 1895, to January, 1897, he was gang foreman on the Missouri Pacific at Kansas City, Mo.; from January, 1897, to January, 1902, machinist and shop foreman at Osawatomie, Kan.; January, 1902, to January, 1905, division foreman at Hoisington, Kan.; January, 1905, to February, 1906, master mechanic at Ft. Scott, Kan.; February, 1906, to July, 1912, master mechanic at Kansas City, Mo.; July 1, 1912, to September, 1915, general master mechanic of the Western division of the same road.

J. E. O'BRIEN, who has been appointed mechanical superintendent of the Missouri Pacific-St. Louis, Iron Mountain & Southern, was born on December 4, 1876, at Stillwater, Minn. He completed his education at the University of Minnesota in 1898 and in the same year entered railway service as special

RAILROAD CLUB MEETINGS

Club	Next Meeting	Title of Paper	Author	Secretary	Address
Canadian	Oct. 12	Electric Lighting of Railway Cars	E. S. M. McNab	James Powell	St. Lambert, Que.
Central	Nov. 12			Harry D. Vought	95 Liberty St., New York.
New England	Oct. 19	The Architect in Railroad	L. G. Morphy	Wm. Cade, Jr.	683 Atlantic Ave., Boston, Mass.
New York	Oct. 15	The Value of Motor Cars	W. R. McKeen	Harry D. Vought	95 Liberty St., New York.
Pittsburgh	Oct. 22	Annual Meeting		L. B. Anderson	207 Penn. Station, Pittsburgh, Pa.
Richmond	Oct. 11	Signaling in General	H. W. Griffin	F. O. Robinson	C. & O. Ry., Richmond, Va.
St. Louis	Oct. 8	Fires from Locomotive Sparks	L. W. Wallace	B. W. Frauenthal	Union Station, St. Louis, Mo.
South'n & S'w'rn				A. J. Merrill	Box 1205, Atlanta, Ga.
Western	Oct. 19			Jos. W. Taylor	1112 Karpen Bldg., Chicago, Ill.
Western Canada				Louis Kon	Box 1707, Winnipeg, Man.

apprentice with the Northern Pacific at Livingston, Mont. From November 1, 1901, to November 25, 1903, he had charge of the general inspection of material and tests at St. Paul, Minn. From that time until December 1, 1904, he served as master mechanic of the Dakota division at Jamestown, N. D., following which he held the position of assistant shop superintendent at South Tacoma, Wash. From August 1, 1909, to January 1, 1910, he was mechanical engineer of the same road at St. Paul, Minn. On January 1, 1910, he became superintendent of motive power for the Western Pacific at San Francisco, Cal., and held this position until October 8, 1913, when he was appointed assistant mechanical superintendent of the Missouri Pacific, with headquarters at St. Louis, Mo. In his new capacity as mechanical superintendent Mr. O'Brien will remain in St. Louis.

W. O. THOMPSON has been appointed superintendent of rolling stock of the New York Central for the lines west of Buffalo, with headquarters at Cleveland, Ohio. Mr. Thompson

was born in July, 1861, at Clayton, Mich., and was educated at Adrian, Mich., high schools. He began railway work in 1880, on the Ft. Wayne, Jackson & Saginaw, and remained with that road until it became a part of the Lake Shore & Michigan Southern. From 1884 to 1890 he served as a locomotive engineman, and then was appointed traveling engineer of the Lake Shore & Michigan Southern, remaining in that position until August, 1893. He was then engine despatcher from 1893 to 1900 on the same road. In 1901 he was



W. O. Thompson

appointed general locomotive inspector of the New York Central & Hudson River. The following year he was appointed superintendent of motive power on the Rome, Watertown & Ogdensburg division, and in 1907 became district master car builder at East Buffalo, N. Y., which position he held at the time of his recent appointment as superintendent of rolling stock for the New York Central lines west of Buffalo.

MASTER MECHANICS AND ROAD FOREMEN OF ENGINES

T. A. ALBRIGHT, foreman engineer of the Texas & Pacific, has been appointed road master mechanic, with headquarters at Marshall, Tex.

R. M. BOLDRIDGE has been appointed master mechanic of the Appalachian Northern, with office at Port St. Joe, Fla., succeeding J. P. Dolan, resigned.

JOHN R. BOWEN has been appointed assistant road foreman of engines of the Delaware & Hudson at Oneonta, N. Y., succeeding C. D. Perry, promoted.

F. C. CARLSON, assistant master mechanic of the Texas & Pacific, has resigned to become master mechanic of the International & Great Northern, with headquarters at San Antonio, Texas.

D. I. CLOUGH, master mechanic of the Oregon Electric and the United Railways, at Portland, Ore., has had his jurisdiction extended to include the Spokane & Inland Empire.

W. H. FLETCHER has been appointed district master mechanic,

District No. 1, Lake Superior division of the Canadian Pacific at North Bay, Ont., succeeding L. G. Roblin, resigned.

JOSEPH PETER HEINZER has been temporarily appointed road foreman of engines of the Northern Pacific at Pasco, Wash., succeeding Robert Erwin Wilkinson.

T. C. HUDSON, division master mechanic, Quebec grand division of the Canadian Northern at Joliette, Que., has had his jurisdiction extended over the car department.

GRANT W. LILLIE has been appointed master mechanic of the Bingham & Garfield, with headquarters at Magna, Utah.

P. LINTHICUM, assistant superintendent of shops of the Chicago, Rock Island & Pacific at Silvis, Ill., has been appointed acting master mechanic of the Missouri division with headquarters at Trenton, Mo., succeeding E. J. Harris.

J. H. MCALPINE, formerly locomotive foreman of the Canadian Northern at Winnipeg, has been appointed master mechanic with jurisdiction over territory between Parry Sound, Port Arthur and Cedar Lake, Ont., with office at Parry Sound, Ont.

C. D. PERRY, assistant road foreman of engines of the Delaware & Hudson, has been appointed road foreman of engines with office at Oneonta, N. Y., succeeding O. E. Ackart, assigned to other duties.

WILLIAM VICTOR WICKS has been promoted from locomotive engineer of the Northern Pacific to the position of road foreman of engines.

CAR DEPARTMENT

G. E. DECKER has been appointed car foreman of the repair yard of the Grand Trunk Pacific at Transcona, Man., succeeding J. Reeves.

RALPH L. CHANDLER has been appointed district master car builder of the New York Central, with headquarters at East Buffalo, N. Y. Mr. Chandler was born on June 4, 1875, at



R. L. Chandler

Milford, N. Y., and was educated in the public and high schools of Buffalo, N. Y. He began railway work on June 28, 1891, with the New York Central & Hudson River and served as machinist's apprentice until October, 1894. He was then to December of the following year a machine hand in the mill of the Pullman Company at Buffalo. From January, 1896, to September, 1897, he was car builder with the American Car & Foundry Company, at Buffalo, and then re-entered the service of the New York Central & Hudson River

as car repairer. He was promoted to foreman in January, 1898, becoming assistant general foreman in September, 1900, and three years later was appointed piecework foreman on the western division. In January, 1911, he was appointed superintendent of shops at East Buffalo, and the following August was made division general foreman of the Pennsylvania division of the same road. On October 22, 1912, he was promoted to supervisor of piecework, covering the car and locomotive departments, which position he held at the time of his recent appointment as district master car builder of the New York

Central, with headquarters at the East Buffalo car shops, as above noted.

A. M. HILBORN has been appointed general car foreman of the Illinois Central, with office at Memphis, Tenn., succeeding E. A. Nix.

A. P. JANDER has been appointed general foreman of the Atchison, Topeka & Santa Fe at Trinidad, Col., succeeding P. B. Coffelt, deceased.

SHOP AND ENGINE HOUSE

J. J. CAREY, master mechanic of the Texas & Pacific at Marshall, Tex., has been appointed superintendent of shops in that city.

L. A. CLEARY has been appointed general foreman of the Canadian Pacific, with supervision over the back shop and roundhouse at McAdam, N. B., succeeding W. Wells, transferred.

JOHN H. PONTIUS, general engine inspector of the Pennsylvania Lines west of Pittsburgh at Columbus, Ohio, has retired after 50 years of continuous service with the road.

JOHN D. ROGERS has been appointed assistant roundhouse foreman of the Oregon Short Line, at Pocatello, Idaho.

H. SHALER has been appointed locomotive foreman of the Canadian Northern at Crowsnest, B. C., succeeding J. A. Mad-dick.

J. S. SCHNEIDER, machine shop foreman, has been appointed general foreman in charge of the erecting and machine shop of the Texas & Pacific at Marshall, Tex.

W. B. WOOD has been appointed acting assistant superintendent of shops of the Chicago, Rock Island & Pacific at Silvis, Ill., succeeding P. Linthicum, promoted.

G. H. LAYCOCK, heretofore locomotive foreman of the Grand Trunk Pacific at Endako, B. C., has been appointed locomotive foreman at Jasper, Alta., succeeding D. W. Hay.

PURCHASING AND STOREKEEPING

G. C. HARPKE has been appointed storekeeper of the Lake Superior division of the Northern Pacific, at Duluth, Minn., succeeding W. L. Peabody.

W. L. PEABODY, storekeeper of the Lake Superior division of the Northern Pacific, with headquarters at Duluth, Minn., has been appointed storekeeper of the St. Paul division, with office at Mississippi street, St. Paul, Minn.

OBITUARY

MENDES COHEN, a former well-known railroad engineer, died at his home in Baltimore, Md., on August 13, at the age of 84. Mr. Cohen began his career in the locomotive works of Ross Winans, at Baltimore. From 1851 to 1855 he was in the engineering department of the Baltimore & Ohio Railroad. From 1855 to 1875 he served the following companies as superintendent, assistant superintendent, controller or president: The Hudson River Railroad, the Ohio & Mississippi, and the Philadelphia & Reading; the Lehigh Coal & Navigation Company, and the Pittsburgh & Connellsville Railroad. He was long president of the Maryland Historical Society, retiring only two years ago.

J. J. MORAN, formerly master mechanic of the Houston & Texas Central at Ennis, Tex., died on July 29, at Marlow, Okla., at the age of 66 years.

FRENCH EMBARGO ON MACHINE TOOLS.—Machine tools and parts thereof have been placed on the embargo list by France, effective August 1.—*Iron Age*.

SUPPLY TRADE NOTES

C. B. Bouton, formerly president of the Union Foundry Works, Chicago, died at his home in that city on August 26.

The Boss Nut Company, Chicago, has moved its offices from the Railway Exchange Building to 1744-48 North Kolmar avenue.

The Pratt & Whitney Company, New York, has moved its Chicago sales office to the Sharples building on Washington boulevard and Jefferson street.

W. Van Ausdall, an electrical engineer of Cincinnati, Ohio, has been appointed superintendent of the C. & C. Electric & Manufacturing Company, Garwood, N. J.

E. D. Graff, for several years in the sales department of the Pittsburgh office of Joseph T. Ryerson & Sons, has been transferred to the sales department of the Chicago office.

Alexander Wilson, for many years superintendent of the railroad department of the Cambria Steel Company, died at his home in Johnstown, Pa., on August 30 at the age of 75.

The Franklin Railway Supply Company, New York, has opened an office in the Transportation building, Montreal, Canada, in charge of J. S. Coffin, Jr., Canadian sales manager.

The Loco Light Company, Indianapolis, Ind., has been incorporated for the manufacture of headlights, with a capital of \$10,000, and directors, R. H. Pyle, L. J. Isbell, G. D. Thornton.

The Q & C Company, New York, has secured exclusive control of the Peffer air brake hose protector, which was previously sold by the Railway Economy Device Company, Chicago. This device will henceforth be known as the Q & C-Peffer hose protector.

David Newhall has opened an office in the Lincoln Building, Philadelphia, Pa., and represents in the eastern district the National Boiler Washing Company, and the National Waste Company, both of Chicago. Mr. Newhall will handle also various lines of railway and mill supplies.

W. H. P. Fisher has been appointed sales manager of the L. M. Booth Company of New York, manufacturers of the Booth water softeners. Mr. Fisher has been selling water softening plants to railroads for 12 years. He will make his headquarters at the company's engineering department in Jersey City, N. J.

A. Q. Tucker, vice-president of the Hydraulic Press Manufacturing Company, Mt. Gilead, Ohio, has been elected president, succeeding M. Burr Talmage; W. G. Beebe has been elected vice-president, succeeding Mr. Tucker; F. B. McMillin continues as general manager and secretary, and M. W. Spear has been elected treasurer, succeeding H. B. McMillin.

The S. K. F. Ball Bearing Company was incorporated in Hartford, September 4, with \$2,000,000 capitalization, to engage in the manufacture of ball bearings. The former American S. K. F. Ball Bearing Company has been a selling organization for the bearings made by the parent Swedish Company known as the Aktie Bolaget Svenska Kullagerfabriken of Gothenburg. The new company will build a factory at Hartford to manufacture bearings in this country, but the S. K. F. steel will be imported from Sweden.

H. M. Roberts, until recently railroad representative of the General Lead Battery Company, has been appointed sales engineer of the railroad department of the Edison Storage Battery Company, Orange, N. J. Mr. Roberts graduated in 1905 from the Sheffield Scientific School with the degree of electrical engineer, and for six years was connected with the engineering department of the New York Telephone Company in power-plant work. He later spent several years in general contracting engineering on railroad and other large enterprises with James Stewart & Co., Inc., New York.

The du Pont powder interests have made a large investment in shares of the Baldwin Locomotive Works. It has been reported that they have secured enough of the stock to give them control, but Pierre S. du Pont, the president of the du Pont de Nemours Company, has refused either to confirm or deny the report. The Baldwin Locomotive Works has been a corporation in its present form only since June 7, 1911. At that time it acquired the property of Baldwin Locomotive Works, incorporated June 7, 1909, to take over the entire property of Burnham, Williams & Co., which had been operating the business known as Baldwin Locomotive Works, founded in 1831, by Matthias Baldwin.

Edward M. Grove, treasurer of the McConway & Torley Company, Pittsburgh, Pa., died on Thursday, August 26. Mr. Grove was born in Chambersburg, Pa., on October 12, 1857. He



E. M. Grove

went to Philadelphia when 14 years old and worked for a time in a printing office. In 1876 he became a telegraph operator. After three years of work as operator he was made district superintendent of the Pullman Company at Cincinnati, Ohio, and was later transferred to Jersey City, N. J. In 1886 he became assistant general manager of the Wagner Palace Car Company, with office in New York. In 1889 he resigned to become associated with the McConway & Torley Company. He has thus been 26 years with that company

and for the last 15 years has been treasurer. Mr. Grove was president of the Railway Supply Manufacturers' Association in 1910 and in 1911, and devoted his time and thought generously to the interests of that association.

Roland L. Taylor, a member of the firm of William A. Read & Co., New York, has completed negotiations for the purchase of the Midvale Steel Company, Nicetown, Philadelphia, Pa., for a syndicate headed by William Ellis Corey, at one time president of the United States Steel Corporation. The Midvale Steel Company is engaged in the manufacture of axles, wheels, steel parts, forgings, etc. It is also well equipped to supply cannon, armor plate and other munitions of war, but has done but little in that line during the present war. It is expected that it will immediately secure a number of large orders for munitions. It is also rumored that the Midvale Steel Company may be but one of a number of companies which will be secured by the same interests.

The Railway Periodicals Company, Inc., has been incorporated under the laws of New York state and will henceforth publish the Railway Master Mechanic, Railway Engineering and Maintenance of Way and the Monthly Official Railway List, these papers having formerly been published by the Railway List Company, Chicago. The officers of the new company are as follows: Ernest C. Brown, publisher of Gas Age, president; Charles S. Meyers, vice-president and general manager, and S. A. Bates, secretary-treasurer. Benjamin Norton, at one time president of the Toledo, St. Louis & Western, has been made editor-in-chief, George S. Hodgins, managing editor, and Laurence A. Horswell, associate editor. The Railway Periodicals Company, Inc., will have offices in the Vanderbilt Concourse Building, New York, and that will be the office of publication.

CATALOGS

ARMCO IRON.—The American Rolling Mill Company, Middletown, Ohio, has issued a booklet describing the products made from Armco iron. This gives in some detail the various forms in which this material is produced and the manner of application in various forms of construction.

FACTORY AND OFFICE EQUIPMENT.—The Manufacturing Equipment & Engineering Company, Boston, Mass., has recently issued three books relating respectively to the company's sanitary bubbling fountains, its line of sanitary washbowls and its metal lockers for factory, office and other use.

DEFEATING RUST.—The American Rolling Mill Company, Middletown, Ohio, has issued an attractive illustrated booklet giving the story of ingot iron, describing the qualities of this material, its method of manufacture, and the various uses to which it is adapted. The book is illustrated with a number of typical illustrations of these uses.

VERTICAL OIL ENGINES.—This is the title of Bulletin No. 501, recently issued by the National Transit Company, Department of Machinery, Oil City, Pa. The booklet deals particularly with the type VT-13, two-cycle, single-cylinder, vertical oil engines, made by this company, and it contains detailed descriptions of the machine itself and its parts.

CAST IRON PIPE.—The Central Foundry Company, of New York, has issued a small pamphlet entitled, "Cast Iron Soil Pipe v. Wrought Pipe," which is devoted to a discussion of the relative durability of the two kinds of pipe as ascertained from samples of wrought iron pipe taken from the Waldorf-Astoria and of cast iron pipe taken from the old Astor House.

"SAVING SET-UPS IN RAILROAD SHOPS."—This is the title of a booklet which has recently been issued by the Lucas Machine Tool Company, Cleveland, Ohio. The booklet relates particularly to the Lucas "Precision" boring, drilling and milling machine, and aims to show wherein that machine is productive of efficiency in the railroad shop. The catalog is well illustrated and attractively gotten up.

CORROSION.—THE CAUSE, THE EFFECT, THE REMEDY—The Stark Rolling Mill Company, Canton, O., has issued a 100-page pamphlet which calls attention to the marked increase in the tendency to corrosion attending the introduction of sheet steel manufactured by the Bessemer or open hearth processes. An account is also given of the various causes of corrosion and describes also the manner in which these troubles have been overcome in Toncon metal. Fifty pages describe and illustrate the various uses for this product.

LOCOMOTIVES.—The Baldwin Locomotive Works has recently issued Record No. 81, describing and illustrating the triple articulated or Triplex locomotive recently built by that company for the Erie, and Bulletin No. 82, showing a number of views of Baldwin locomotives for export. The former booklet contains a detailed description of the Matt H. Shay, as the locomotive has been named, well illustrated by half-tone views of the locomotive and various of its parts and line drawings showing the side elevation and cross sections. There are a number of pages dealing also with the Erie's Santa Fe type locomotives. The booklet dealing with locomotives for export contains views of a number of locomotives supplied on recent orders. The introduction touches upon the favorable position of the company as to export business and contains the interesting statement that the Baldwin Locomotive Works has been exporting locomotives since 1838, when two engines were shipped to Cuba. The illustrations given include views of the Pacific type locomotive built for New Zealand, the Pechot type locomotive built for the French government, the Mallet type engine built for the Archangel Railway of Russia, and a large number of others.

Railway Age Gazette

MECHANICAL EDITION
INCLUDING THE
AMERICAN ENGINEER

PUBLISHED ON THE FIRST THURSDAY OF EVERY MONTH BY THE
SIMMONS-BOARDMAN PUBLISHING COMPANY
WOOLWORTH BUILDING, NEW YORK, N. Y.

CHICAGO: Transportation Bldg. CLEVELAND: Citizens' Bldg.
LONDON: Queen Anne's Chambers, Westminster.

EDWARD A. SIMMONS, *President* L. B. SHERMAN, *Vice-President*
HENRY LEE, *Secretary-Treasurer*

The address of the company is the address of the officers

ROY V. WRIGHT, *Editor*

R. E. THAYER, *Associate Editor* A. C. LADDON, *Associate Editor*
C. B. PECK, *Associate Editor*

Subscriptions, including the eight daily editions of the *Railway Age Gazette* published in June in connection with the annual conventions of the Master Car Builders' and American Railway Master Mechanics' Associations, payable in advance and postage free:

United States, Canada and Mexico..... \$2.00 a year
Foreign Countries (excepting daily editions). 3.00 "
Single Copy 20 cents

Entered at the Post Office at New York, N. Y., as mail matter of the second class.

WE GUARANTEE, that of this issue 7,000 copies were printed; that of these 7,000 copies 6,219 were mailed to regular paid subscribers, 85 were provided for counter and news companies' sales, 257 were mailed to advertisers, exchanges and correspondents, and 439 were provided for new subscriptions, samples, copies lost in the mail and office use; that the total copies printed this year to date were 67,300, an average of 6,118 copies a month.

The RAILWAY AGE GAZETTE, MECHANICAL EDITION, and all other Simmons-Boardman publications are members of the Audit Bureau of Circulations.

Protection of Iron and Steel

J. W. Gibbons, of the Santa Fe, who served as chairman of the test committee of the Master Car and Locomotive Painters' Association during the past year, and who was recently elected second vice-president of that association, contributes an article in this issue on the protection of iron and steel, which is of more than ordinary interest. The report of the test committee, which was abstracted in our October issue, page 539, attracted wide attention, as a result of which a number of inquiries were sent to Mr. Gibbons by master painters and other railway officers. Prompted by these requests Mr. Gibbons has prepared an article covering the technical as well as the practical side of the question. Deductions which may be drawn from the tests are clearly outlined; the article itself is brief and to the point and is not too technical for the busy practical man.

Railroads Have Started Buying

On another page we publish an item showing that the railroads of the United States placed orders during the month of October for 280 locomotives, 21,339 freight cars and 16 passenger cars. These figures are taken largely from the Railway Age Gazette, and a perusal of the equipment and supplies columns in the general news pages of recent issues of that paper develops some very interesting facts. In the week ended October 22 it reported orders for no less than 90 locomotives, 6,800 freight cars and 14 passenger cars, this making that week the best thus far this year, with the exception of the third week in May, when the Pennsylvania placed its order for 50 locomotives and 16,145 cars. But the third week in October played a "poor second fiddle" to the last week in the month, for in the issue of October 29 the Gazette was able to report orders for 177 locomotives and over 13,000 freight cars. October is always a good time of the year for the equipment companies, but times are rare when contracts are let for approximately \$8,000,000 for locomotives, \$240,000 for passenger cars and \$20,000,000 for freight cars, a total of \$28,240,000 for new equipment in a period of from 10 to 14 days. The orders for locomotives for domestic service reported to October 29 this year already total over 1,000, as compared with 848 reported to the end of October last year. Domestic orders for freight cars are also ahead of the figures for the first 10 months

CONTENTS

EDITORIAL:	
Protection of Iron and Steel.....	553
Railroads Have Started Buying.....	553
A Unique Competition.....	554
Piston Valve Packing Ring Contest.....	553
Smokeless Firing and Passenger Revenue.....	554
Another Car Department Competition.....	554
Fire Losses and the Mechanical Department.....	554
Relationship of the Mechanical and Stores Department.....	555
Car Inspectors' Competition.....	555
New Books.....	555
GENERAL:	
First 4-8-2 Locomotives in Canada.....	556
Smokeless Locomotive Operation without Special Apparatus.....	561
Fire Hazards at Coaling Stations.....	562
Indicator Reducing Motion.....	563
Calibration Charts for Vanderbilt Tenders.....	563
Results of the Master Mechanics' Association Letter Ballot.....	565
Hot Trailer Bearings.....	565
Abatement of Locomotive Smoke in Cincinnati.....	566
CAR DEPARTMENT:	
Cleaning Carpets in Terminals.....	567
Result of M. C. B. Letter Ballot.....	567
Cleaning Triple Valves.....	568
Four-Wheel Trucks for Passenger Cars.....	569
Thawing Out Frozen Cars.....	574
Ordering and Handling Lumber.....	574
The Making of Good Car Inspectors.....	575
SHOP PRACTICE:	
Drill Motor Extensions.....	579
Protection of Iron and Steel.....	580
Device for Placing Air Pumps.....	581
Helping the Apprentice.....	582
Piston Valve Packing Rings.....	583
Quadruple Tool for Planing Shoes and Wedges.....	584
Standardization of Crane Motors.....	585
Start the Apprentice Right.....	585
Exhaust Passage Drain Valve.....	586
Pneumatic Hammer.....	586
Engine Failures, Their Causes and Cure.....	587
Chuck for Finishing Air Pump Packing.....	589
Machine Tool Lubricant Pump.....	589
High Speed Steel Tipped Tools.....	590
Tempering Tools with the Electric Furnace.....	590
Removable Wedge Bolt.....	591
Shoe and Wedge Chuck for Milling Machine Table.....	591
Gas Brazing Furnace.....	591
Handling Coupler Yokes.....	592
Portable Oxy-Acetylene Welding and Cutting Outfit.....	592
NEW DEVICES:	
Universal Elliptic Spring Forming Machine.....	593
Automatic Drifting Valve.....	593
Condenser Vacuum Pump.....	594
High Speed Radial Drill.....	595
Smokebox Blower Fitting.....	595
Boring Tool Holders.....	595
Automatic Non-Return Valve.....	596
Sullivan Piston and Valve Stem Packing.....	596
Safety Belt Stick.....	597
Worm Wheel Cutting Machine.....	597
NEWS DEPARTMENT:	
Notes.....	598
Meetings and Conventions.....	599
Personals.....	600
Supply Trade Notes.....	601
Catalogs.....	602

of 1914, the orders this year totaling approximately 72,000, as compared with 67,820 to October 30, 1914. If we add the 400 locomotives and over 13,000 freight cars ordered by the Russian Government of firms in the United States and Canada, we find that the totals to October 29, 1915, are already 1,400 locomotives and 85,000 cars, with two of the best months of the year to run. The total orders for locomotives and freight cars reported by the Railway Age Gazette for the entire year 1914 were but 1,265 and 80,264 respectively.

**A
Unique
Competition**

The competitions which we have announced in recent months have met with such hearty response on the part of our readers that we are encouraged to try out a rather unique scheme with the hope of receiving an even greater response. Many officers and foremen who have tried to improve the efficiency of their organizations or departments have adopted simple little schemes to inspire their men to do better and more efficient work. For instance, a master mechanic equipped a spare room next to his general foreman's office with a long table, having in it a drawer for each of the foremen. The foremen had been in the habit of keeping their papers and lunches at different places in the shop, but this brought them all together about the big table at the lunch hour. The effect in securing better co-operation and teamwork was almost immediate. There are hundreds of simple schemes of this sort that have given good results. We will give \$10 each for the best three letters, from a practical standpoint, which are received on or before January 1, 1916, describing methods which have been tried out and have helped to "Tone up an Organization." The letters must not exceed 700 words in length. Those that are not awarded a prize, but which we may wish to publish, will be paid for at our regular rates.

**Piston Valve
Packing Ring
Contest**

The importance of carefully fitting the packing rings to the piston valve and maintaining them carefully was clearly brought out in the papers submitted in the competition on Piston Valve Packing Rings, which closed October 1. It is difficult to measure accurately the loss in steam, and therefore fuel, due to improperly fitted rings, but there can be no question but that the time and labor expended in doing the work properly is very much worth while.

From a careful study of the articles submitted in the contest the judges awarded the prize to W. F. Lauer, general foreman of the Illinois Central, at Memphis, Tenn., this article being printed elsewhere in this issue. Mr. Lauer was the only participant who went into detail concerning the machining of the packing rings. It has been clearly shown that the cost of manufacture is not the only thing to be considered, as a cheaply and poorly made ring may be a costly ring from a service standpoint. It would, therefore, be very desirable to hear from others of our readers regarding the methods followed on their roads for handling this very important detail in locomotive maintenance.

**Smokeless Firing
and
Passenger Revenue**

The Baltimore & Ohio Employees' Magazine for September prints, in its "Merit Roll" columns, a letter from P. C. Allen, a superintendent of that road, which reads, in substance, as follows:

"On No. 525 yesterday, I was sitting on the observation platform when I heard a passenger remark: 'You cannot sit out this way on some railroads.' I asked: 'Why can't you?' And he answered: 'So many of them burn soft coal and it is so dirty.' When I got off he said: 'I am coming this way again.' The fireman, C. A. Straw, was making a clean run of it and with soft coal!"

Fireman Straw was doing two things for his road—saving

fuel by careful firing and advertising the road in the best possible way, i. e., by doing what he could to make the passengers comfortable. It is well known that passenger business does not, as a general rule, produce very large earnings and it is also well known that a smoky and dirty observation platform is worse than if none were provided, for under those conditions it becomes nothing but a tantalization. The best advertisement for a road is a satisfied patron. It is surprising how the reputation of the service a road renders spreads throughout the traveling public. Fireman Straw certainly deserves meritorious recognition. This incident may also serve as another argument for increased supervision in locomotive operations and the education of firemen.

**Another
Car Department
Competition**

"Lessons to Be Learned From Experience with Steel Freight Cars," is the subject of a competition, to close December 1, 1915, as announced in our October issue. All steel and steel underframe freight cars have been in use for many years in large numbers. In the earlier stages of their development much trouble was caused by defects in design and construction, but gradually most of these have been eliminated. As the cars have grown older, however, certain weaknesses have become apparent under continued service which were not evident before the wear and tear had begun to affect the different parts. What are the weak points, and how can they be strengthened, thus reducing the cost of maintenance and extending the life of the car? We want to hear from the practical man as to the difficulties which confront him in the repair and maintenance of these cars. We want his ideas as to how the construction can be improved. We want also to hear from the designer, if he has followed the cars closely after they have gone into service and is familiar with their performance. The topic, as it is expressed in the opening sentence of this note, defines exactly what we want to bring out. A prize of \$35 will be given for the best article on this subject received at our offices in the Woolworth building, on or before December 1, 1915. Other articles which we may select for publication will be paid for at our regular rates. The judges will base their decision on the practical value of the suggestions which are made.

**Fire Losses and
the Mechanical
Department**

At the recent convention of the Railway Fire Protection Association, the committee on statistics presented a statement of causes of fires and the fire losses, which was obtained from 41 representative roads, reporting and operating mileage of 102,462 miles, or approximately 40 per cent of the entire country, for the two calendar years 1913 and 1914. From this statement the following is taken as being of special interest to the mechanical department:

	Number of Fires	Loss	Percentage of Total Loss
Ashes and hot cinders.....	301	\$51,213.57	2.7
Coal from locomotive fireboxes.....	493	117,874.83	4.4
Friction, hot boxes, etc.....	116	90,042.68	1.2
Sparks from locomotives.....	3,008	899,177.90	26.7
Spontaneous combustion.....	393	258,852.33	3.5
Torches.....	142	57,426.92	1.3
Waste and wooden lockers.....	31	13,936.09	.3
		\$1,488,524.32	40.1

The grand total of the complete losses reported for the two years was \$5,753,663.90, and the greatest individual item given in the statement was \$1,504,486.72 for fires caused from unknown causes. While the totals given in the table above may not be entirely chargeable to the mechanical department, the items enumerated are such as to indicate that the mechanical department may do much to reduce them.

Care should be taken to see that all the ashes and hot cinders removed from locomotives at the cleaning pits are carefully extinguished before being placed in cars or near any wooden

structure. Improper maintenance of ash pans is responsible for damage caused by hot coals from the locomotive fireboxes. Sparks from locomotives, the largest item in the above table, and representing 26.7 per cent of all the fires in the two years mentioned, are a direct result of the improper maintenance of the front end, diaphragm, screens, etc. If this item were pro-rated to all the railroads in this country it would show that about \$1,125,000 per year was spent in paying claims from this source, which represents about \$25 per road engine per year. It would seem that it would be a profitable investment carefully and properly to maintain locomotive front ends. The other causes, spontaneous combustion, torches, waste and wooden lockers, are items that particularly interest the shop forces, and emphasize the value of keeping the shops clean and neat.

Relationship of the Mechanical and Stores Department

The ambition of mechanical department officers is to keep the power and rolling stock in proper condition and have as great a proportion as possible available for service. This requires a supply of material without which the department will be helpless. The stores department, which sells this material to the mechanical department, is therefore an important factor in the success of the mechanical department. However, its officers also have ambitions. Its duty is to keep enough stock on hand to adequately meet the demands of its customers, and at the same time to keep the amount of money tied up by the investment in material to the lowest possible sum. Its success depends on the proper proportioning of these two factors. The work of the stores department is clerical; but slight mechanical knowledge is necessary. Unassisted it has only the experiences of the past to suggest the needs of the future. With the never ending desire to keep the stock as low as possible, it can readily be seen that unless it is accurately informed as to the needs of the future, the mechanical department may find its effectiveness "nipped in the bud" by lack of material.

It is evident that with the providing of material in the hands of a separate department, which seeks to keep the stock as low as possible, a very close and friendly relation should exist between the two departments. With material such as used daily in more or less uniform quantities there is little if any difficulty. It is the sudden demands that create trouble. Many times, and in fact in most every case, the mechanical department can predict fairly accurately, the amount of material that will be required for the future, and it is to its best interest to see that the stores department is fully informed regarding these requirements. In cases of emergency also the stores department can be of great service to the mechanical department.

Is it not fair and just, therefore, for the mechanical department to do its share toward making the stores department a success and in assisting it to keep the stock down to the lowest practicable point. Without this assistance disastrous results may follow, and with it the relationship between the two departments will be most friendly. The success of both departments is interdependent—without the assistance of the mechanical department the stores department cannot properly supply the necessary material without greatly sacrificing its investment efficiency, and without the assistance of the stores department the mechanical department cannot keep its shop output up to the desired standard.

Car Inspectors' Competition

As noted in our October issue, the car inspectors' competition was the most successful in the number of papers received of any competition that we have ever held. While

some of the papers were incomplete, and a number of them were much alike, several exceedingly strong articles were received discussing the question from widely varying viewpoints. It

may be said also that the competition was one of the most successful as to the importance of the facts which were developed. Several of the most valuable of the contributions will be published complete in this and succeeding issues; the others will probably be combined into symposiums covering different phases of the subject, but giving each contributor credit for such part as may have been taken from his article.

The prize of \$35 has been awarded to A. M. Arr, of the Bessemer & Lake Erie, Greenville, Pa. He discusses quite fully the selection, training and continued development of the car inspector. Particularly good are his suggestions as to selection, and his recommendations concerning the recording of individual efficiency in order that weak spots may be located and strengthened, and the entire staff encouraged to put forth their best efforts in the knowledge that improved individual efficiency will be recognized. This, with the periodical examinations, should do much toward encouraging the inspectors to putting forth their best efforts. The typical examination paper which accompanied Mr. Orr's paper is worth reading and checking by those who are specially interested in this subject.

Of quite a different nature is the contribution by E. C., which is also published in this issue, and which in many ways supplements Mr. Orr's paper. It is well worth reading and studying carefully. One thing is evident—the car inspector's job is no snap. E. C. emphasizes the difficulties under which these men have to work and specially directs attention to the lack of cooperation on the part of the yard operating forces. Let us hope that these conditions are not general, although from reading between the lines of some of the other papers it is evident that they are far more so than they should be. Is it not time that the operating department officers can be an important factor in securing better car inspectors by being more sympathetic toward these men, realizing, as they must, that the work is vitally important to successful and efficient operation and that the inspectors must be allowed a sufficient amount of time for the proper performance of their duties?

We congratulate the car inspectors and their friends on the splendid showing which they made in the competition, and take this opportunity of again thanking them for their cordial cooperation.

NEW BOOKS

Official Proceedings of the Ninth Annual Convention of the Master Boilermakers' Association. Bound in cloth; 230 pages, 6 in. by 9 in. Illustrated. Published by Harry D. Vought, secretary. Price, \$1.00.

This volume contains the official proceedings of the ninth annual convention of the Master Boilermakers' Association, held at Hotel Sherman, Chicago, on May 25-28, 1915. The papers and committee reports presented at this convention contain much information of value pertaining to boiler shop practice and boiler and tank construction and should be of considerable value to those having to do with locomotive boiler maintenance. The value of the volume as a reference book is considerably increased by a table of contents. It is well printed and well bound.

How to Make Low Pressure Transformers. By Prof. F. E. Austin, Hanover, N. H. 17 pages, 4 illustrations, 4 1/4 in. by 7 1/4 in. Bound in cloth. Published by the author. Price, 40 cents.

This is the second edition of this book published by the author, and contains detailed instructions regarding the design, construction and the operation of small transformers. With these instructions a transformer for 110 or 220 volt line circuits with a frequency of 60 cycles can be stepped down to a minimum of eight volts. The author goes very thoroughly into the matter of construction, and shows it may be built without the use of expensive tools or machinery. Transformers made according to these instructions have given an output of 100 watts with an efficiency of over 90 per cent.

FIRST 4-8-2 LOCOMOTIVES IN CANADA

Two Engines Built by the Canadian Pacific Have Engine Trucks Equalized with Driving System

BY W. H. WINTERROWD

Assistant to Chief Mechanical Engineer, Canadian Pacific, Montreal, Que.

The heavier class of passenger service on the Canadian Pacific has been very largely handled by Pacific type locomotives which are divided into two classes, one with 22½ in. by 28 in. cylinders and 75 in. driving wheels, and the other with 21 in. by 28 in. cylinders and 69 in. driving wheels. The boilers of both classes carry a pressure of 200 lb. The class with the larger driving wheels was fully illustrated and described in the March, 1913, issue of *The American Engineer*, page 117.

On account of the heavy grades on some of the divisions and on account of the desirability of maintaining schedule speeds with heavy trains without double-heading over these divisions, it became necessary to consider a more powerful locomotive. With this in view the railway company built and put into service in August, 1914, two Mountain type locomotives which are the first of their type built in Canada. These locomotives were

BOILER

Engine 2900 is equipped with the Gaines combustion chamber firebox. The boiler contains 210 2¼-in. tubes and 30 5¼-in. flues. The length over tube sheets is 20 ft. 8½ in. The boiler of engine 2901 is equipped with an ordinary wide firebox and brick arch. It contains 43 2¼-in. tubes, 136 2½-in. tubes and 30 5¼-in. flues, the length over tube sheets being 25 ft. 4½ in. By the American Locomotive Company's method of calculating boiler capacity, the boiler equipped with the Gaines combustion chamber is rated at approximately 110 per cent and the boiler with the ordinary wide firebox, approximately 105 per cent. By the same method the boilers of the Pacific type locomotives are rated at approximately 90 per cent.

The firebox equipped with the Gaines combustion chamber is 7 ft. 4¾ in. wide and approximately 13 ft. 6 in. long at the

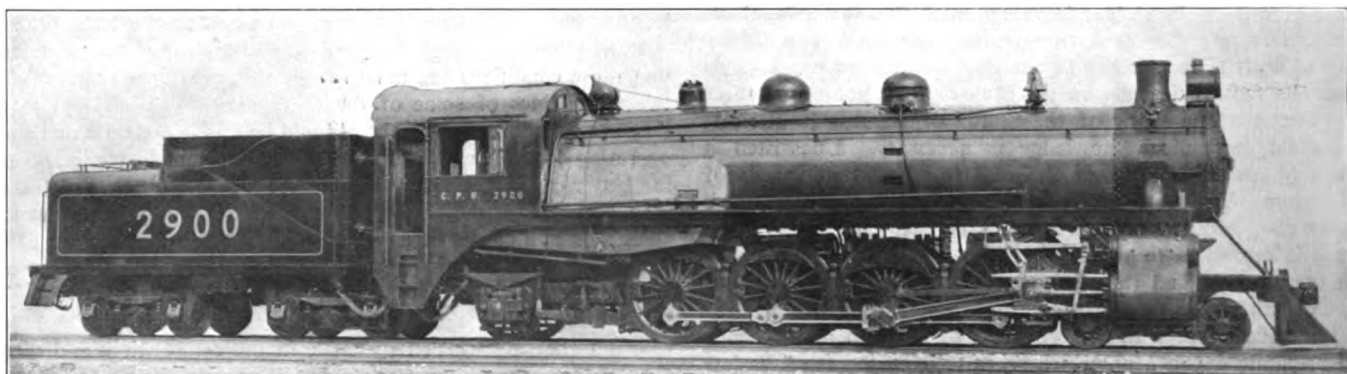

Canadian Pacific Mountain Type Locomotive with Gaines Firebox

designed and built at the company's Angus shops, Montreal, and are identical in practically every respect with the exception of the boilers, one of which is equipped with a Gaines combustion chamber firebox. They have 23½ in. by 32 in. cylinders, 70 in. driving wheels and carry a boiler pressure of 200 lb.

The Pacific type locomotives with the larger drivers and cylinders have a rated tractive effort of 32,100 lb., their total weight in working order, including the tender, being 361,000 lb. On account of bridge and right of way restrictions the Mountain type locomotives are not as heavy as a number of locomotives of the same type in service in the United States. They have,

mud ring. The grates extend toward the back tube sheet 7 ft. 11 in. and have an area of 59.6 sq. ft. At the front of the grates is placed the vertical brick wall of the combustion chamber which is 10 in. thick and carries five vertical air passages, each 3 in. in diameter. The distance between the wall and the back tube sheet is 4 ft. 11½ in. The brick arch is carried on four 3½-in. arch tubes which are straight, except at the back tube sheet where they are curved on a radius of 3 ft. so that the ends form a right angle with the tube sheet.

On account of the depth of the firebox the floor of the combustion chamber is raised above the level of the grates in order

	Can. Pac. 2900*	Can. Pac. 2901	Rock Island	Ches. & Ohio	Great North.	Missouri Pacific	Seaboard Air Line
Tractive effort, lb.	42,900	42,900	50,000	58,000	61,900	50,400	47,800
Weight, total, lb.	286,000	286,000	333,000	330,000	326,000	296,000	316,000
Weight on drivers	192,000	192,000	224,000	239,000	218,000	208,000	210,500
Diam. of drivers, in.	70	70	69	62	62	63	69
Cyls., diam. and stroke	23½x32	23½x32	28x28	29x28	28x32	28x28	27x28
Steam pressure, lb.	200	200	185	180	180	170	190
Heating surface, tubes and flues	3,402	3,929	3,805	3,795	4,200	3,165	3,396
Firebox heating surface	265	221	312	337	340	285	319
Superheater heating surface	760	943	944	845	1,075	761	865
Total equivalent heating surface	4,807	5,564	5,533	5,399	6,153	4,592	5,012
Grate area	59.6	59.6	62.7	66.7	78.0	56.5	66.7
Factor of adhesion	4.48	4.48	4.48	4.12	3.68	4.14	4.38

* Boiler equipped with Gaines combustion chamber.

however, a rated tractive effort of 42,900 lb. and weigh 443,000 lb., including the tender. With an increase in weight of 22.7 per cent, tractive effort has been increased 33.6 per cent.

The accompanying table compares briefly the Canadian Pacific Mountain type locomotives and some of the same type operating in the United States.

to clear the rear driving wheels. These wheels are directly under the combustion chamber and extend into the firebox, the floor of the combustion chamber being inclined from each side of the firebox toward the cinder hopper.

The mud ring is forged and slopes downward from both front and back toward the base of the vertical bridge wall. The

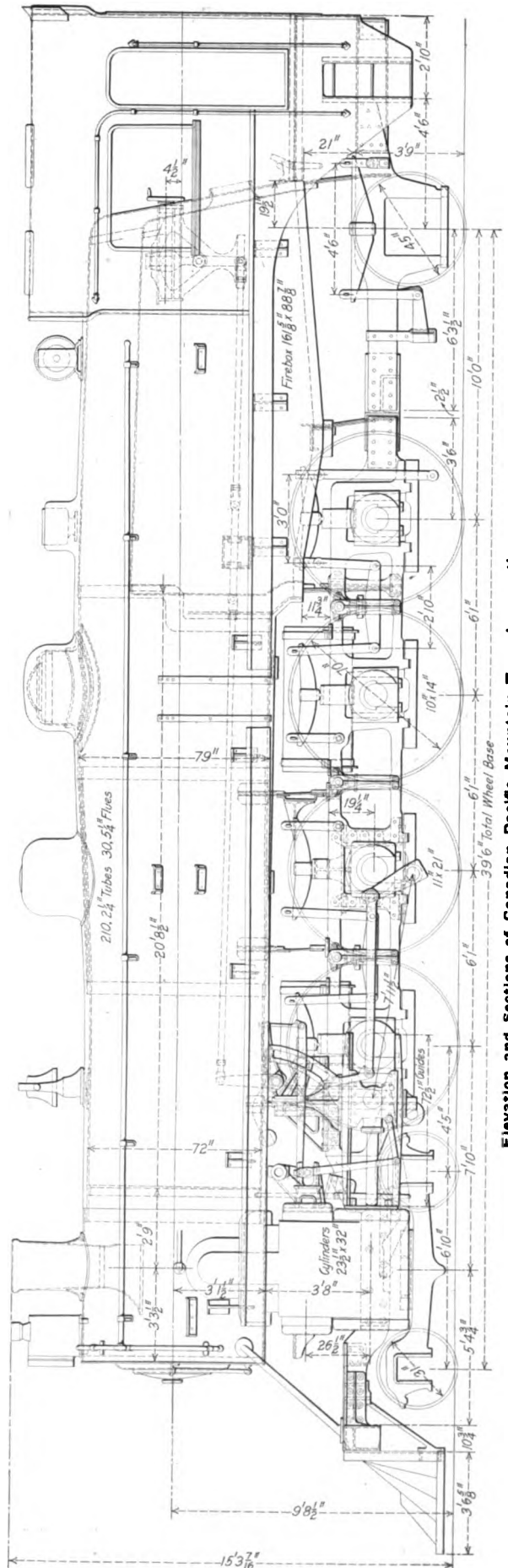
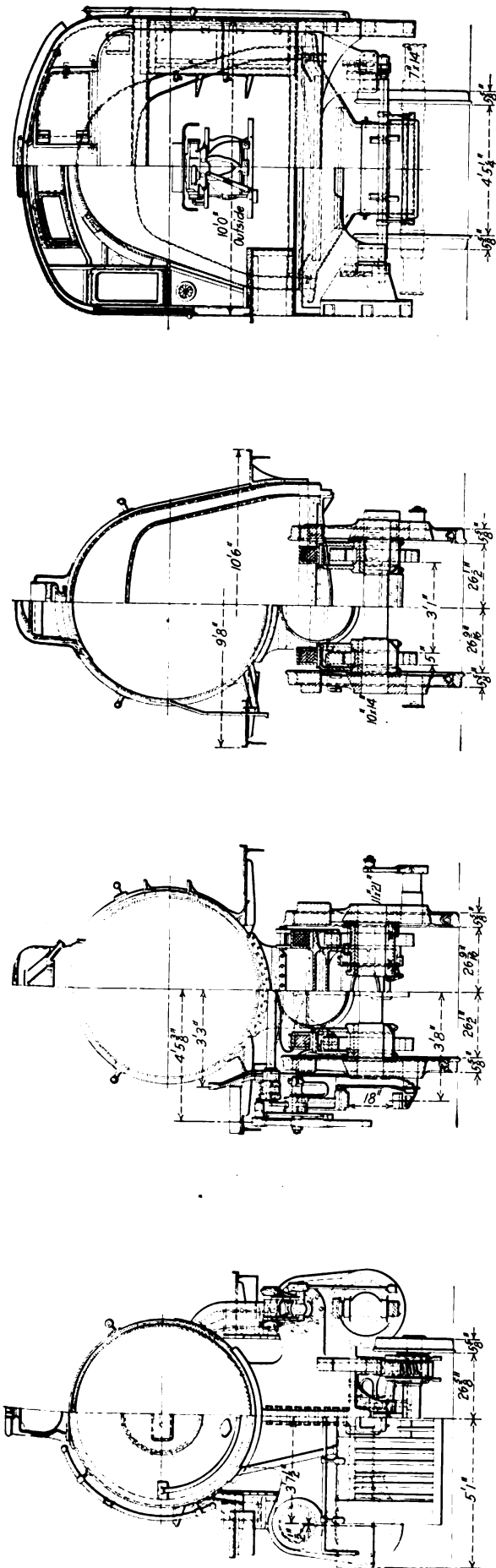

Elevation and Sections of Canadian Pacific Mountain Type Locomotive

firebox is supported by expansion sheets at the front, back and center. The center sheet is supported at the base on a steel casting bolted between the rear frames and is fastened at the top to the transverse steel casting that supports the combustion chamber wall. This casting extends the full width of the firebox

and are 3½ in. wide by 8½ in. deep where the front frame filler or spider casting is bolted. The rear frames and the pedestal binders are of mild steel. The main frames are spaced 39½ in. between centers and the rear frames 74¼ in. between centers.

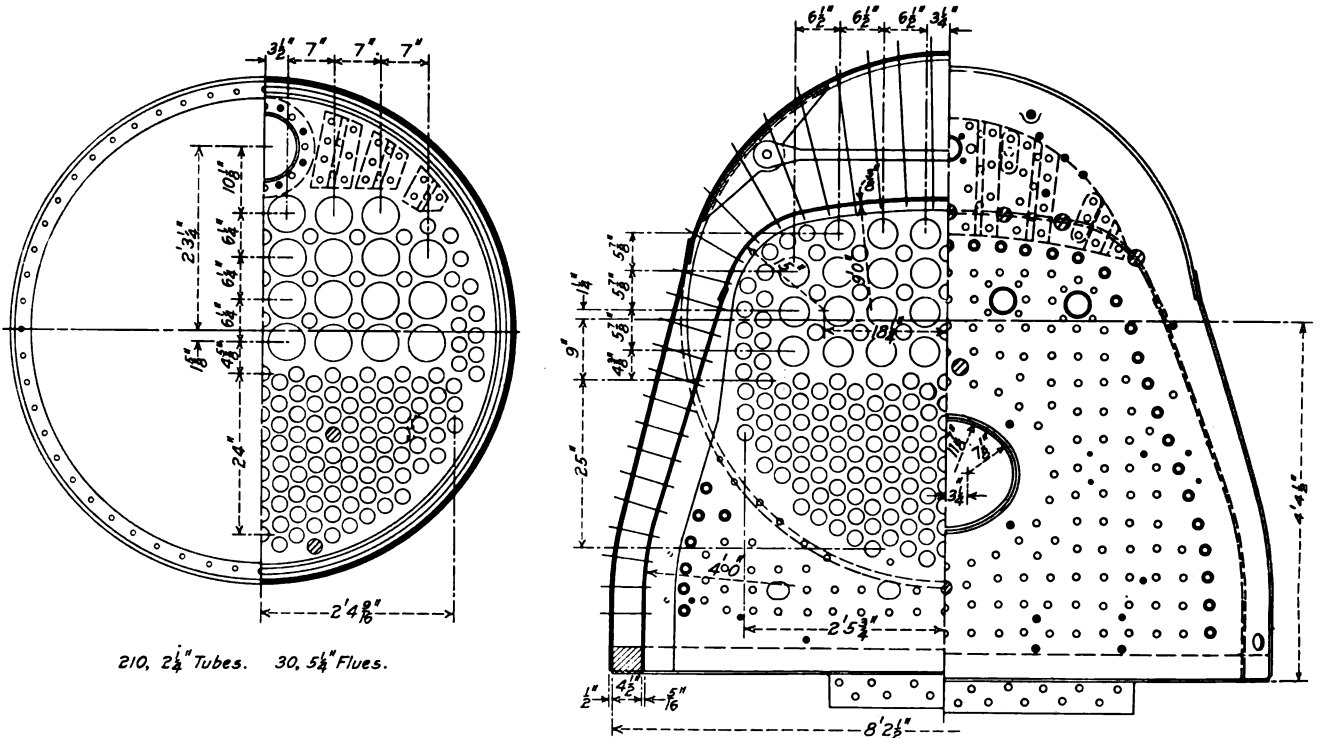

Cross Sections of Boiler of Engine 2900

and is lipped under the mud ring to serve the double purpose of wall support and firebox support. The expansion sheets are double, each being made of two ¾-in. plates separated at the top and bottom by ½-in. liners. They fit against shoulders at the top and bottom, thus relieving the bolting from shearing stresses.

The tubes in the boiler of engine 2901, which are 25 ft. 4½ in. long, were beaded into place before the boiler was applied to the frames, with the boiler turned upside down. The center

CYLINDERS

The cylinders are of cast iron and are the same as those used on the Canadian Pacific standard Mikado and ten wheel type hump switch engines with the center line of the steam chest ½ in. inside of the center line of the cylinder. In designing these cylinders particular attention was given to the steam and exhaust passages, which are unusually direct and of liberal cross sectional area. The cylinders and steam chests are fitted with gray iron bushings the walls of which are one inch thick. Canadian

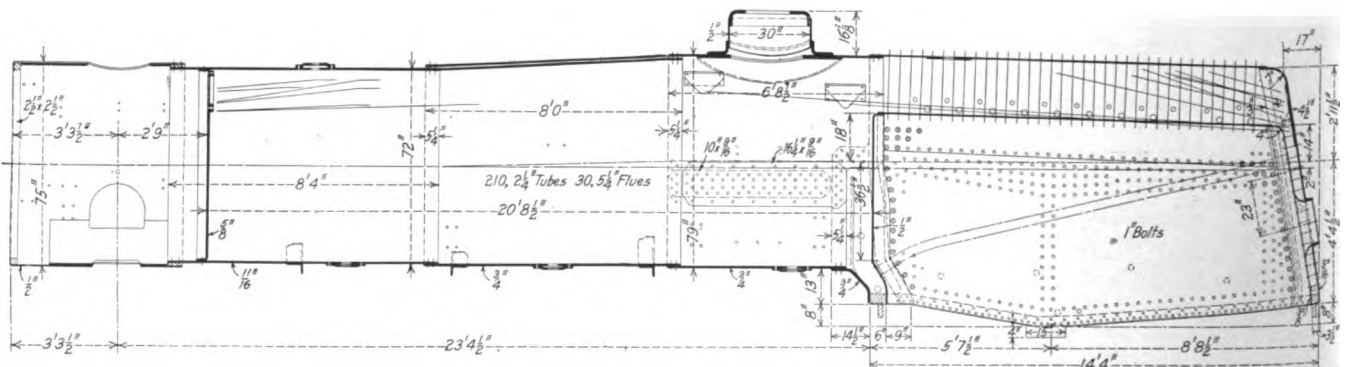

Longitudinal Section of the Boiler of Engine 2900

sag of the tubes was then toward the top of the boiler and when it was righted the tubes tended to straighten out. A test showed that they were practically straight and up to the present time they have given no more trouble than the shorter tubes in engine 2900.

FRAMES

The main frames of both engines are of vanadium cast steel, the upper rails having a section 5 in. wide by 6½ in. deep and the lower rail a section 5 in. wide by 3¾ in. deep. The single rail front frames are cast integral with the main frames. They have a section 3½ in. wide by 12 in. deep under the cylinders

Pacific standard 12-in. piston valves are used and both the pistons and valves are fitted with gray iron snap rings. Each cylinder is bolted to its respective frame with 10 bolts, each 1½ in. in diameter and the cylinders are bolted together at both front and back with single rows of nine 1¼-in. bolts. There is also a bottom bolting flange containing four 1½-in. bolts.

ENGINE TRUCK

The equalizing system between the engine truck and driving wheels is that patented by H. A. Hoke, assistant engineer, Pennsylvania Railroad, and in use on a number of Pennsylvania locomotives with four-wheel engine trucks. Its appli-

cation to the Pennsylvania class E6s Atlantic type was described in detail in the *Railway Age Gazette, Mechanical Edition* for February, 1914, page 66. The weight on the engine truck is equalized with the weight on the first and second pair of driving wheels, while the third and fourth pair of driving wheels are equalized with the trailer truck. The main equalizer is of wrought iron of the fish belly type. It is 6 ft. 9 in. long over all and at the point where the fulcrum pin is applied has a cross sec-

tion 4 in. wide by 12 in. deep. The back end is supported by a hanger from the cross equalizer. The front end is supported in a specially designed casting which forms a part of the engine truck. The fulcrum pin is supported in two steel castings fitted and bolted together directly beneath the cylinders. Each casting is bolted to a main frame with eight of the 1½-in. bolts which are used to secure the cylinder castings to the frame, and is also bolted to the bottom of the cylinder casting with six 1½-in. bolts. The castings are bolted together at the center with four 1½-in. and two 1¼-in. bolts. The 1½-in. bolts pass through the bottom bolting flanges of the cylinder castings. The castings are carefully fitted and bolted into place and serve also

back of which is a full depth opening 7½ in. wide through which the front end of the main equalizer passes. The bearing surface on the end of the equalizer is convex with a radius of 3½ in, and rests upon a concave cast steel equalizer seat supported by the engine truck center casting. The equalizer seat is 11¾ in. in diameter and is provided with guiding ribs which engage the sides of the equalizer to prevent the seat from turning under the latter. The lower part of the casting is rectangular in form and fits between transverse vertical walls on the cast steel truck frame cross tie, which forms the guiding surfaces for the lateral swing of the truck in curving.

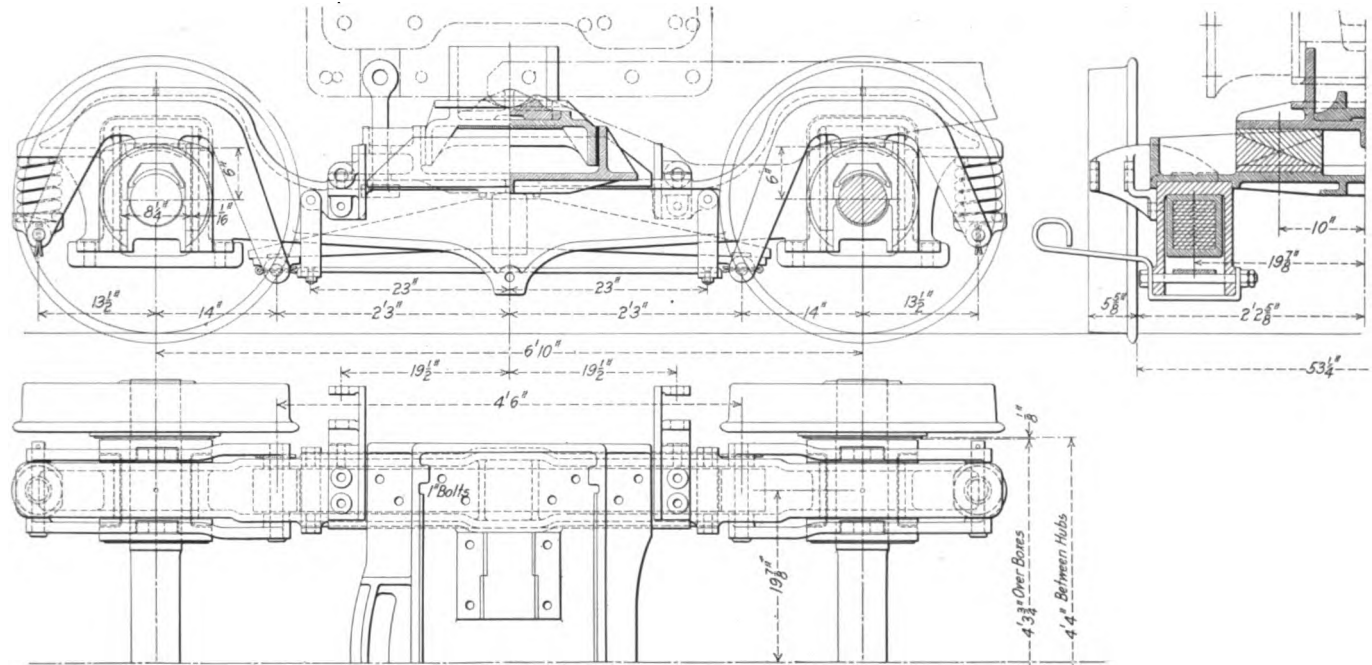

Arrangement of Details of the Leading Truck

tion 4 in. wide by 12 in. deep. The back end is supported by a hanger from the cross equalizer. The front end is supported in a specially designed casting which forms a part of the engine truck. The fulcrum pin is supported in two steel castings fitted and bolted together directly beneath the cylinders. Each casting is bolted to a main frame with eight of the 1½-in. bolts which are used to secure the cylinder castings to the frame, and is also bolted to the bottom of the cylinder casting with six 1½-in. bolts. The castings are bolted together at the center with four 1½-in. and two 1¼-in. bolts. The 1½-in. bolts pass through the bottom bolting flanges of the cylinder castings. The castings are carefully fitted and bolted into place and serve also

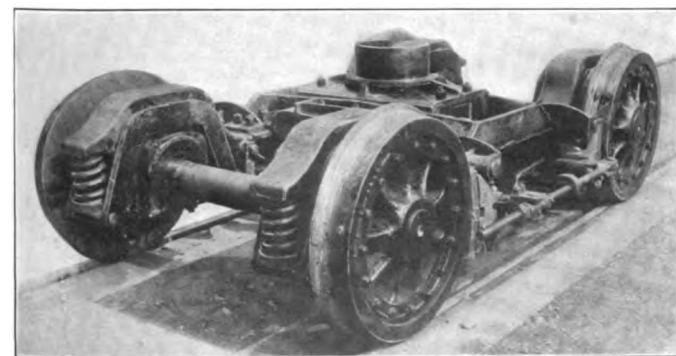

Leading Truck for Canadian Pacific Mountain Type Locomotives

as a front frame cross tie, engine truck center casting guide and support for the engine truck safety hanger.

To form a guide for the truck center casting, each of the fulcrum castings is so cored that when both are in final position the center portion forms a circular vertical guide 15½ in. in diameter with walls ¾ in. thick. In the back of this guide is a vertical opening 7½ in. wide. Into the guide thus formed is

The truck is centered by double-faced wedges, the wearing faces of which are inclined 1 in. in 2½ in. The top pair of wedges are bolted to the under side of the center casting and the bottom pair to the floor of the truck frame cross tie. The vertical guiding walls of the latter are joined at the ends to longitudinal vertical walls 4¼ in. high, thus forming a rectangular reservoir open at the top, which is kept partly filled with oil for the lubrication of the centering wedges. Oil pipes readily accessible from the front of the engine lead to this reservoir. Wrought iron wearing strips are riveted to the inside of the front and back guiding walls.

Through a reinforced extension on the front of the cross tie casting is a slot 2½ in. wide and 16 in. long formed on a radius of 2 ft. 8 in. Through this slot is passed the engine truck safety hanger, a wrought iron eye bolt 1¾ in. in diameter with a tee head on the bottom end. This safety hanger is hung on a 1¾-in. wrought iron pin supported by the equalizer fulcrum castings.

The engine truck side frames are of steel cast integral with the journal box pedestals, which are spaced 6 ft. 10 in. between centers. They are of channel section with side walls 7/8 in. thick and are spaced 39¾ in. apart from center to center. In the center of each side frame is cast a spring seat in which rests a semi-elliptic spring made up of 13 7/16-in. by 5-in. plates. The springs

are supported at the ends on cast iron spring seats which are secured to the inner ends of inverted U-shaped equalizers. The middle point of these equalizers rests on the truck boxes and the outer ends carry the lower seats for coil springs, the upper ends of which bear against the side frames. With 31-in. wheels mounted on axles with 6-in. by 12-in. journals, the truck, complete in working order, weighs 11,250 lb. Actual service has demonstrated that this truck equalized with the drivers makes a very easy riding engine.

REVERSE GEAR

The engines are both equipped with a screw reverse gear of the type shown in one of the drawings. The screw mechanism

running board; on engine 2901 it is fastened to the barrel of the boiler. The front and back sections of the reach rod are fitted with cast steel jaws screwed into place and held with jam nuts, while the intermediate rod is fitted with eye ends, 1 $\frac{3}{4}$ -in. mild steel pins being used to connect the front and back to the intermediate section. The reach rod enters the cab practically parallel with the running board.

Both engines are equipped with Cole driving boxes on the main journals. These journals are 11 in. by 21 in. while the others are all 10 in. by 14 in. The trailing truck journals are 7 in. by 14 in. Canadian Pacific standard vestibule cabs are provided on both engines. On account of the screw reverse

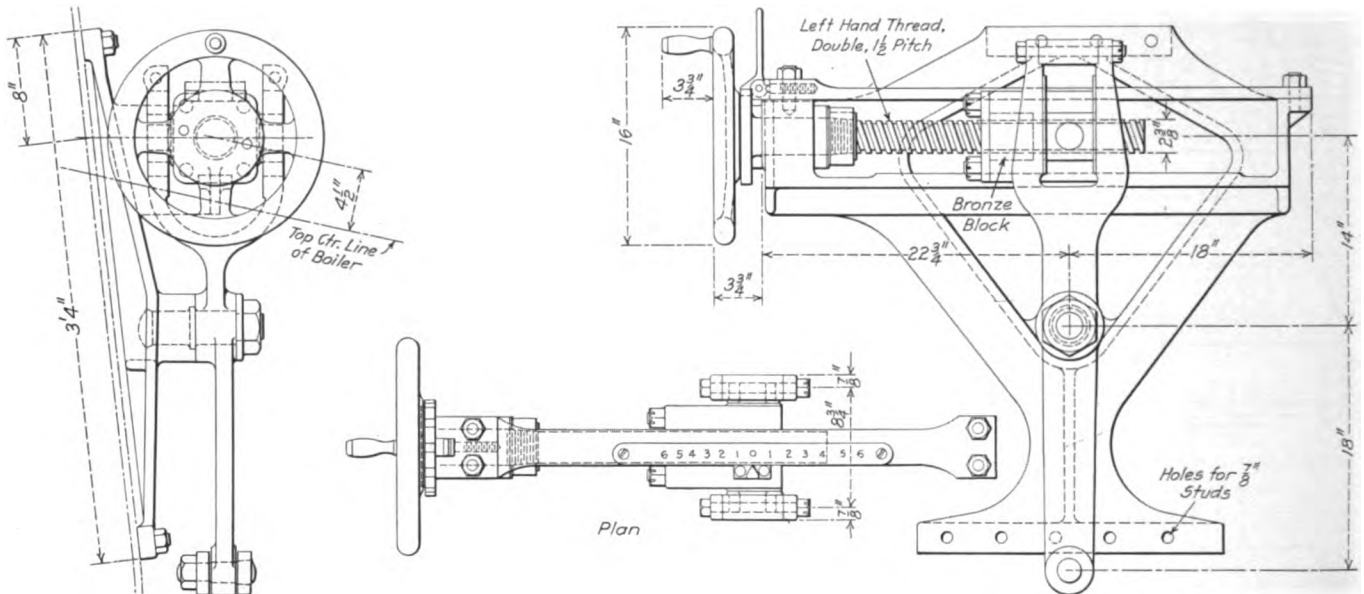

Screw Reverse Gear Used on Canadian Pacific Mountain Type Locomotives

is supported by a cast steel bracket fastened to the side of the firebox with $\frac{7}{8}$ -in. studs. A wrought iron reverse lever, which transmits the motion from the screw to the reach rod, is also supported from the bracket by a wrought iron, case hardened pin 2 $\frac{1}{2}$ in. in diameter. Below the fulcrum pin the lever has a section approximately 1 $\frac{1}{4}$ in. thick by 4 in. wide. The upper end of the lever is made with jaws which engage swivel guides supported by the screw block. The main jaw straddles the screw block and the secondary jaws each straddle a swivel guide filler blocks held in place by $\frac{3}{4}$ -in. bolts closing the top of the secondary jaws. These jaws are faced with 3/16-in. case hardened steel liners, held in place with 5/16-in. counter-sunk rivets.

The screw rod is 2 $\frac{3}{8}$ in. in diameter and is provided with threads of 1 $\frac{1}{2}$ -in. pitch. When the gear is in forward position the link block is in the lower half of the link. In order to maintain the standard direction of movement for the top of the hand wheel, which is from left to right toward forward motion and from right to left to reverse, the threads on the screw are made left hand. To move the gear from center to forward motion the screw block moves forward. The lever reverses this motion causing the reach rod to move backward. The forward end of the reach rod is connected to the top arm of a bell crank, the horizontal arm of which extends backward, thus lowering the link blocks when the reach rod moves backward. The hand wheel, screw bearings, locking latch and position indicator are the same as those of the standard screw reverse gear used on Pacific and Mikado type locomotives.

The reach rod, which is very long on both engines, is made in three sections of extra heavy wrought iron pipe. The intermediate section works in a cast iron guide with bushed bearing surfaces. On engine 2900 this guide is bolted to the right side of the firebox close to the throat sheet and slightly above the

gear occupying practically the entire space between the boiler and side of the cab, a non-lifting injector is applied on the right side of the engine, a lifting injector being placed on the left side.

The tenders have a coal capacity of 12 tons, and a water capacity of 6,000 Imperial gallons and are equipped with air operated coal pushers. They are Canadian Pacific standard.

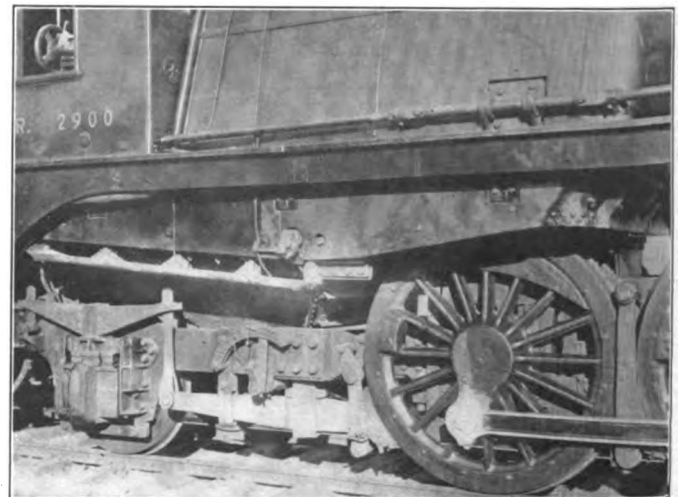

View at the Rear End of Engine 2900, Showing the Driving Wheel Extending into the Combustion Chamber Portion of the Firebox

known as the combination type in which the underframe forms a part of the tank structure.

In addition to its use in the main frame, Vanadium steel is used in the main crank pins.

The principal data and dimensions are given in the following table:

<i>General Data</i>	
2900—Class H-1-a	2901—Class H-1-b
Gage.....4 ft. 8½ in.	4 ft. 8½ in.
Service.....Passenger	Passenger
Fuel.....Bituminous	Bituminous
Tractive effort.....42,900 lb.	42,900 lb.
Weight in working order.....286,000 lb.	286,000 lb.
Weight on drivers.....192,000 lb.	192,000 lb.
Weight on leading truck.....53,000 lb.	52,000 lb.
Weight on trailing truck.....41,000 lb.	42,000 lb.
Weight of engine and tender in working order.....443,000 lb.	443,000 lb.
Wheel base, driving.....18 ft. 3 in.	18 ft. 3 in.
Wheel base, total.....39 ft. 6 in.	39 ft. 6 in.
Wheel base, engine and tender.....66 ft. 6 in.	66 ft. 6 in.
<i>Ratios</i>	
Weight on drivers ÷ tractive effort.....4.48	4.48
Total weight ÷ tractive effort.....6.665	6.665
Tractive effort × diam. drivers ÷ equivalent heating surface*.....625	539
Equivalent heating surface* ÷ grate area.....80.7	93.4
Firebox heating surface ÷ equivalent heating surface, per cent.....5.5	3.92
Weight on drivers ÷ equivalent heating surface*.....39.9	34.5
Total weight ÷ equivalent heating surface*.....59.5	51.4
Volume both cylinders.....16.08 cu. ft.	16.08 cu. ft.
Equivalent heating surface* ÷ vol. cylinders.....299	346
Grate area ÷ vol. cylinders.....3.71	3.71
<i>Cylinders</i>	
Kind.....Simple	Simple
Diameter and stroke.....23½ in. by 32 in.	23½ in. by 32 in.
<i>Valves</i>	
Kind.....Piston valve	Piston valve
Diameter.....12 in.	12 in.
Greatest travel.....6½ in.	6½ in.
Outside lap.....15/16 in.	15/16 in.
Clearance (exhaust).....3/16 in.	3/16 in.
Lead in full gear.....5/16 in.	5/16 in.
<i>Wheels</i>	
Driving, diameter over tires.....70 in.	70 in.
Driving, thickness of tires.....3½ in.	3½ in.
Driving journals, main, diameter and length.....11 in. by 21 in.	11 in. by 21 in.
Driving journals, others, diameter and length.....10 in. by 14 in.	10 in. by 14 in.
Engine truck wheels, diameter.....31 in.	31 in.
Engine truck, journals.....6 in. by 12 in.	6 in. by 12 in.
Trailing truck wheels, diameter.....45 in.	45 in.
Trailing truck, journals.....7 in. by 14 in.	7 in. by 14 in.
<i>Boiler</i>	
Style.....Extended wagon top	Wagon top
Working pressure.....200 lb. per sq. in.	200 lb. per sq. in.
Outside diameter of first ring.....72 in.	72 in.
Firebox, length and width.....161¼ in. by 88¾ in.	96¼ in. by 88¾ in.
Firebox plates, thickness.....½ in., ¾ in., 5/16 in.	½ in., ¾ in., 5/16 in.
Firebox, water space.....6 in., 4½ in., 3½ in.	5 in., 4½ in., 3½ in.
Tubes, number and outside diameter.....210—2¼ in.	43—2¼ in., 136—2½ in.
Flues, number and outside diameter.....30—5¼ in.	30—5¼ in.
Tubes and flues, length.....20 ft. 7¾ in.	25 ft. 3¾ in.
Heating surface, tubes.....2,552 sq. ft.	2,887 sq. ft.
Heating surface, flues.....850 sq. ft.	1,042 sq. ft.
Heating surface, firebox.....265 sq. ft.	221 sq. ft.
Heating surface, total.....3,667 sq. ft.	4,150 sq. ft.
Superheater heating surface.....760 sq. ft.	943 sq. ft.
Equivalent heating surface*.....4,807 sq. ft.	5,564 sq. ft.
Grate area.....59.6 sq. ft.	59.6 sq. ft.
Smokestack, diameter.....16½ in.	16½ in.
Smokestack, height above rail.....15 ft. 3 7/16 in.	15 ft. 3 7/16 in.
Center of boiler above rail.....9 ft. 8½ in.	9 ft. 8½ in.
<i>Tender</i>	
Tank.....Water bottom	Water bottom
Frame.....Combined tank and frame	Combined tank and frame
Weight.....157,000 lb.	157,000 lb.
Wheels, diameter.....36¼ in.	36¼ in.
Journals, diameter and length.....6 in. by 11 in.	6 in. by 11 in.
Water capacity.....6,000 Imp. gals.	6,000 Imp. gals.
Coal capacity.....12 tons	12 tons

* Equivalent heating surface = total evaporative heating surface + 1.5 times the superheating surface.

THE PYROMETER IN STEEL MAKING.—In the experiments on rail manufacture which the U. S. Bureau of Standards is conducting at the plant of the Maryland Steel Company, Sparrows Point, Md., particularly with reference to a comparison of Hadfield and domestic ingots, attempts are being made to determine whether it is possible to control the operation of the Bessemer open-hearth and other processes by the aid of the pyrometer.—*The Iron Age.*

SMOKELESS LOCOMOTIVE OPERATION WITHOUT SPECIAL APPARATUS*

BY H. H. MAXFIELD

Master Mechanic, Pennsylvania Railroad, Pittsburgh, Pa.

The problem of eliminating objectionable smoke from steam locomotives is naturally divided into two parts, first, terminal, or engine house operation, and second, road operation. If the elimination of objectionable smoke can be accomplished at engine terminals, and the locomotives turned over to the crews with fires in such a condition that it is not necessary to do much in the way of heavy firing while passing through the restricted area, the problem is more than half solved.

The Terminal Problem.—The first essential is that the locomotive be delivered by the crew at the ashpit with the fire in good condition, i. e., not badly burnt out nor yet full of green coal, but having a medium-sized, bright fire. This permits cleaning and banking the fire with a minimum of smoke.

The second essential is the careful cleaning and rebuilding of the fires and banking them in case the locomotive is to remain at the terminal for any length of time. These operations being completed, the locomotive is moved to the engine house or storage yard, and from then on until the crew assumes charge, the burden is on the engine watcher, who must see that the fire is properly maintained until the crew assumes charge. If the fire is properly cleaned, rebuilt and banked, the engine watcher has a comparatively simple problem confronting him.

The third essential is the proper preparation of the fire for service by the fireman upon taking charge of the locomotive. The first and second essential having been properly taken care of, here again the problem is not difficult.

The methods of cleaning, building up, banking and the building of new fires as practiced at our engine terminals located within the limits of the City of Pittsburgh, are well illustrated by the following instructions:

RULES AND REGULATIONS FOR CLEANING AND BUILDING FIRES IN LOCOMOTIVES

Black smoke shall not be made.
Cleaning Fires.—When cleaning fires at the ashpits, the blower shall be used with sufficient strength to keep down black smoke. One-half of the fire shall be cleaned at a time. After the ashes are knocked out over one-half of the grate surface, this grate surface should then be covered with gas coal, and a layer of low volatile coal placed over this. The good fire should then be thrown over this coal to allow cleaning the other half of the grate. After this half of the grate has been cleaned, it should be covered with a similar amount of gas and low volatile coal, and the burning fuel on the opposite side pulled over it until an even depth of fire is obtained over the entire grate surface. If more coal is then needed to build up the fire the hostler shall use only low volatile coal, which has been thoroughly wet with water.

Banking Fires.—All coal used for this purpose shall be low volatile coal, and shall be thoroughly wet with water. Banking shall be started at the rear end of the firebox and built forward until the fire has been covered within two or three feet of the front flue sheet. The fire shall be heaviest along the side sheets and of minimum depth in the center. In case a banked fire needs more coal supplied, low volatile coal shall be used exclusively. If there is no low volatile coal on the tender the hostler shall report this condition to the engine house foreman and receive instructions.

Building Fires.—The entire surface of the grate shall be covered with 3 in. of gas coal spread over evenly, and upon this an even layer of 4 or 5 in. of low volatile coal thoroughly wet shall be placed. Extreme care shall be used to see that the coal is spread evenly so as to cover the entire grate surface, and no holes should be left in it. Dry shavings shall be distributed over the entire surface of the coal, care being taken that the shavings shall be placed along the side sheets of the firebox. One bucket of shavings, which has been mixed with one quart of fuel oil, shall be evenly distributed on top of the dry shavings. When this has been done, the shavings should then be ignited by a small piece of waste thrown into the middle of the firebox. The blower should then be operated very lightly until the coal shall have become ignited, when the strength of the blower should be increased gradually.

The door shall be kept wide open when fire is started, but after the coal has become thoroughly ignited the door may be closed, depending upon the smoke conditions at the stack. Under no circumstances shall the fire be hooked. If more coal should be needed, wet low volatile coal shall be supplied, but in small quantities. The house blower shall not be used if the locomotive in which fire is being built has 50 lb. steam pressure. When the steam pressure reaches 50 lb. on the locomotive in which a fire is being built, the house blower shall be disconnected.

The use of low volatile coal is to be noted. This coal contains approximately from 20 to 22 per cent of volatile matter. The use of this coal, while not essential to the operation of locomotives at a terminal without objectionable smoke, is unquestionably a great aid, especially at congested points where it is necessary

* Abstract of paper presented at the tenth annual convention of the International Association for the Prevention of Smoke.

to handle a large amount of power in a minimum of time. The placing of a layer of gas coal on the grate under the low volatile coal, when building new fires, as well as when cleaning fires, is an expedient for preventing the low volatile coal, due to its fineness, dropping into the ashpans, thus avoiding the necessity for a second cleaning. As the fire ignites from the top down, the volatile matter from the gas coal is ignited and consumed before passing out of the firebox. The wetting of the coal is an expedient that has given excellent results from a smoke prevention standpoint and has not produced any injurious results. In order to place low volatile coal on the tender, so that it will be accessible, special chutes were installed on the coal wharf, and in order that a limited supply may be accessible when needed, small platform bins have been erected at convenient points so that the hostler can obtain it practically without getting off the locomotive. The low volatile chutes on the wharf have been equipped with sprinkler pipes, so that the coal is wet as it flows into the tenders.

Our method of banking fires not only eliminates, to a large extent, objectionable smoke, but it also enables us to turn the locomotive over to the engine crew with a heavy, bright fire, which requires very little working on the part of the fireman, and this enables him to avoid objectionable smoke. Our 28th Street, Pittsburgh, engine terminal handles, on an average, 175 locomotives in 24 hours. Approximately 35 fires are built daily, about 75 per cent of them being built out of doors. An average of 100 engines per day have fires cleaned or built at this point.

The Road Problem.—The topography of the country in which Pittsburgh is situated seriously complicates the problem of smoke regulation. The problem is a still more complicated one by the movement of heavy tonnage trains originating miles outside of the city limits, then running as high as sixteen or more miles through the city, over comparatively heavy grades, through residential sections, and either through or alongside of important city parks.

Each division handles all smoke regulation matters arising within its own operating territory. A large number of special observers are stationed at the various strategic points for several days at a time, to obtain exact data on the smoke situation. The railroads co-operate in every way with the Bureau of Smoke Regulation of Pittsburgh through its representatives and chief, Mr. Henderson. Copies of daily reports of smoke inspectors are forwarded to the bureau. The railroad takes prompt action on all complaints of objectionable smoke received from the bureau and the bureau is advised as to the result of the investigation of the complaint and what action is taken in order to prevent repetition. All enginemen and firemen have been given printed instructions covering the proper method of firing and operating locomotives in order to obtain efficient and smokeless operation. The essentials of these instructions follow:

The burning of bituminous coal in a locomotive requires air, which must be admitted through the grates and through the fire door.

Smoke means waste of coal and must be avoided. Large quantities of coal placed in the firebox at one time cool down the fire, cause smoke and waste coal; small quantities at regular intervals will keep the fire bright, prevent smoke and take less coal to keep up steam pressure.

Lumps of coal should be broken in pieces not larger than 3 in. A bright and level fire over the whole grate must be carried whenever possible. When a sloping fire is used no more coal should be banked at the door than is necessary.

To prevent smoke and save coal the fire door must be placed on or against the latch after firing coal or using the scraper, slash bar or hook, and when on sidings, in yards, at terminals or before starting.

Before the throttle is closed the blower must be used and the door placed on the latch. Fireman must stop firing long enough before steam is shut off to prevent smoke and waste of coal.

The grates must be shaken as often as necessary to clear the fire of ash and clinker in order to admit sufficient air, and in such a manner as to avoid the loss of good fire. Care should be taken to place the grates level after each operation.

Coal can be saved by the proper use of the injector in pumping the locomotive regularly, and by taking advantage of every opportunity to fill the boiler when not working the locomotive to full capacity; also by using the injector to avoid the safety valve's blowing off.

Coal will be saved by always working the locomotive (except when starting) with a full throttle when the cut-off is one-quarter of the stroke or greater, but if one-quarter cut-off with full throttle gives more power or speed than is needed the reverse lever should be left at one-quarter cut-off and the throttle partially closed as needed.

The railroad feels that considerable progress has been made

in the effort to eliminate objectionable smoke, the best proof of this being the fact that during the first six months of 1915 there was a reduction of over 78 per cent in the number of complaints of objectionable smoke received from the Bureau of Smoke Regulation as compared with the last six months of 1914. In conclusion, it can be said that the spirit of co-operation which exists between the Bureau of Smoke Regulation of the City of Pittsburgh and the railroad officers has been responsible, in the greatest measure, for the results obtained.

FIRE HAZARDS AT COALING STATIONS

At the second annual meeting of the Railway Fire Protection Association, held in Chicago, October 5-7, an interesting report was read on the fire hazards at coaling stations. The following, which concerns the maintenance of coaling stations, is taken from it:

The hazards encountered in the care of coaling stations consist of open lights, poor housekeeping and spontaneous combustion, all of which may be eliminated by the exercise of ordinary care and attention. Open lights, such as torches, lighted matches and lamps, should never be permitted within the building. Bonfires should not be allowed within 50 ft. of the structure. Poor housekeeping is, broadly speaking, a lack of tidiness and order. Oily waste should be deposited in metal cans, which should be emptied daily, and the premises should be kept free of any accumulation of rubbish. All oily clothes should be hung up in standard metal lockers. Oil for lubrication or fuel should be stored in a small metal-clad house located not less than 30 ft. from the main building. Gasoline should be stored in a standard concrete or brick pit located at the same distance.

The danger from locomotive sparks may be reduced to a minimum by destroying birds' nests built on the outside timbers and by keeping the structure in good repair so that there will be no crevices or decayed parts where a spark may lodge. All highly inflammable substances which collect in concealed places and absorb moisture are subject to spontaneous heating and particular attention should be given to preventing accumulations of refuse, oily clothes or waste and coal dust in any part of the station. Spontaneous heating is also due to wet coal being unloaded into the pockets, where it sticks to the sides or bottom and becomes packed, causing it to heat.

It was recommended that the following rules be posted in some conspicuous place at each coaling station:

Bins must be cleaned of all accumulation of coal and coal dust at least once each week, and oftener if thought necessary. At the time the chute is cleaned special attention should be given to the removal of coal dust on all beams.

The engineer must make a careful inspection each day of all bearings and observe the condition of the coal. He shall keep a daily record of these inspections and report them weekly to his superior officer.

Water must not be applied to coal in the cars or in the chute for the purpose of laying the dust.

Greasy clothing and oily waste must not be left in any part of the coaling station.

Smoking in and around the coaling station is forbidden.

Open lights of any description are prohibited, except in case of emergency.

A book will be furnished the operator by the proper division official for the purpose of keeping a record, giving the date of cleaning and describing in detail the manner in which the chute was cleaned. This record must be reported each week by the operator to his superior officer, who will transmit the report monthly to the superintendent.

Fire apparatus of all description must be examined at the time the coal chute is cleaned and defects reported immediately.

Blowers on locomotives or ash pans should not be opened in the vicinity of coaling plants.

INDICATOR REDUCING MOTION

BY HUGH G. BOUTELL

The accompanying sketches show the general arrangement and details of an indicator reducing motion used by one of the southern railroads. It was gotten up by the men in charge of the dynamometer car and has proved very successful in actual service.

The arrangement consists of a wooden arm suspended from a bracket on the running board or guide yoke and connected to the cross-head by a short wooden link. At its upper end the arm is securely attached to a drum, also made of wood and turned with a U-shaped groove on its circumference. To this drum is attached a stout piece of fish line, which runs up through a hole in the running board and over a small sheave supported by a bracket on the running board, to a long coil spring of a type similar to those used for screen doors. The other end of this spring is made fast to the indicator pipe from the cylinders, though, of course, any convenient point of attachment would serve equally as well. Where the fish line joins the spring there is a loop made of iron wire, and into this the cord from the

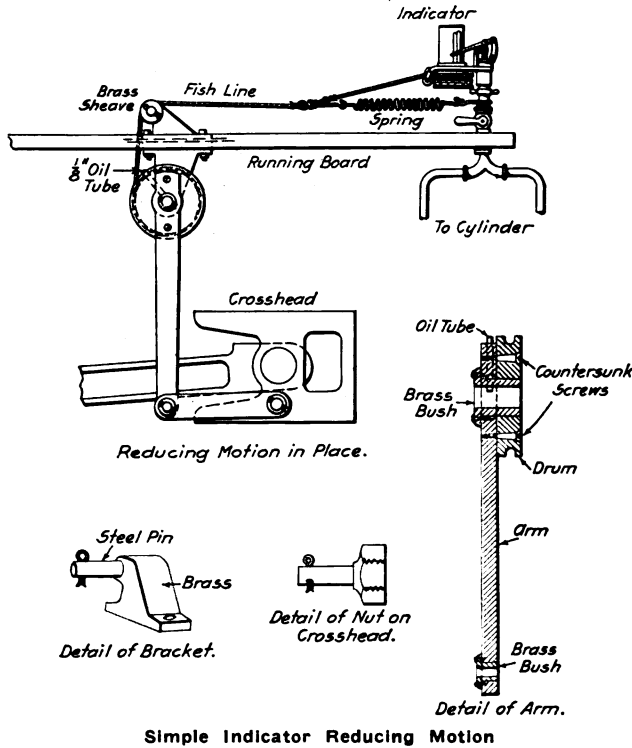

indicator may be hooked. The appearance of the rigging when in place is clearly shown in the sketch.

The arm and drum are made of oak and have an advantage over similar parts made of metal, as they are much lighter and possess very little inertia. Brass bushings are inserted as shown and held in place by screws through flanges on one end of the bushings. The upper bushing is provided with a 1/8-in. oil pipe which passes through a hole in the arm and may be kept filled with waste soaked in oil. The drum and arm are held together by large countersunk screws. The link is merely a straight piece of oak, with a suitable brass bushing at the cross-head end and a pin at the other. For connection to the cross-head a special nut, with a pin on one end, was made to take the place of one of the ordinary nuts. The brackets are simple brass castings, and as the base of the bracket which supports the arm is the same as that of the one for the sheave, only two bolts through the running board are necessary, one additional hole being necessary for the cord to work through. Of course, the design of these brackets can be varied to suit the particular requirements

of the engine, and on some locomotives it will be found more convenient to support the arm from the guide yoke, or perhaps some portion of the valve gear.

By suitably proportioning the length of the arm and the radius of the drum any desired reduction may be obtained, and unlike some forms of reducing motion in common use, this arrangement gives a motion to the indicator drum, which is practically a true reproduction of that described by the cross-head. Where quite a number of tests are being run, covering a comparatively long period of time, the engine may be safely sent out between test runs with the reducing motion in place, as it is very substantial and will require no attention beyond occasional oiling, the same as any of the other moving parts.

CALIBRATION CHARTS FOR VANDERBILT TENDERS

BY TOWSON PRICE

It is generally desirable to have calibration charts, or curves showing the amount of water contained for all depths of water, for all classes of tenders. These charts are very useful in making engine tests where a record is kept of the amount of water used, as it is much easier to measure the depth of water and read the amount from a chart than to weigh the tender repeatedly.

The data for constructing a calibration chart may be obtained by weighing the tender empty and with various heights of water in the tank and drawing the curve through the points so found, or by calculating the tank capacity for various heights of water and so obtaining points on the required curve. If no drawing of the tender is available the first method is the simpler, but care should be taken to have the tender nearly level and water heights should be taken at opposite corners and averaged. If a drawing of the tender is available or can be readily made and it is not convenient to keep the tender out of service while the weights are obtained, it will be necessary to obtain the calibration curve by calculating the tank capacity for various heights of water.

The Vanderbilt tender presents the greatest difficulties to the calculation of capacity for various depths of water, and that

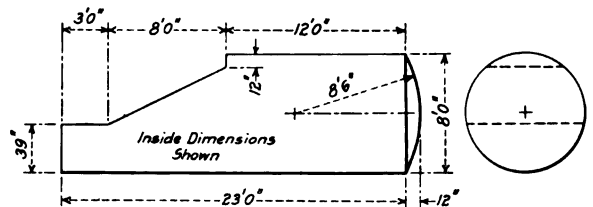

Fig. 1—Water Space Dimensions for a Vanderbilt Tank

type of tank will be considered in this article. The necessary dimensions of one of these tanks are given in Fig. 1. If a drafting room is available, this tank may be laid out to large scale, cut up into horizontal strips, the average length of these strips being obtained by scale and the cross sectional area determined with a planimeter or by multiplying the height by the average width. But if a drawing board is not available or it is desired to make the curves for a number of similar tanks the work may be done by calculation, using a slide rule and a table of areas of circular segments.

For convenience and in order that the two points will be located where a break in the smoothness of the curve takes place, the height will be divided into 20 parts, the height of the coal space slope being divided into 10 equal parts. The 39 in. below the coal space slope is divided into eight parts, and the 12 in. above is divided into three parts. The spherical rear end is treated separately and added. The problem now is to get the area of the circular segmental strips and multiply them by their average lengths. From a table of areas of circular seg-

ments (see Kent, pages 121 and 122), the curve in Fig. 2 may be plotted. Only one-half of the complete curve is plotted, but by the use of two scales this may be made to serve for the complete circle. The scales at the left and bottom serve for segments less than a semi-circle, while those at the top and right are for those larger than a semi-circle. The areas read from this curve must be multiplied by the square of the diameter in inches, and the average length (in inches) of the portion of the tank considered. For the first eight points both the diameter and length are constants, the length being variable for the next 10 points. If the results are to be in gallons the above product must be divided by 231. The total segmental area is read from the curve in Fig. 2, and may be used direct for the first eight points since the other factors in the calculation are constant. For the remaining points, however, it is necessary to use the difference in the areas for successive points and calculate the increments of volume or capacity, adding the results

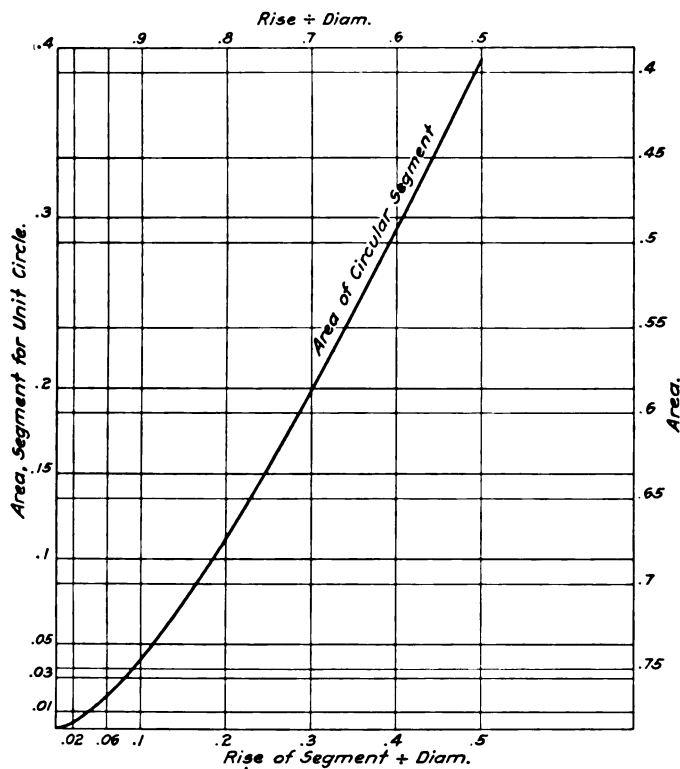

Fig. 2—Area of Circular Segments

to determine the total capacity for each point. The tabulation of the factors entering into the calculations is shown in Table I, these referring only to the cylindrical portion of the tank. The variable multipliers are in each case the average length of the strip in feet, the factor 12 being included in the constant multiplier:

TABLE I—FACTORS FOR CALIBRATING CYLINDRICAL PORTION OF TANK SHOWN IN FIG. 1.

Point No.	Area, Total	Area, Difference	Constant Multiplier	Variable Multiplier	Total Multiplier
1	.0147	11000
2	.0409	11000
3	.0739	11000
4	.1118	11000
5	.1536	11000
6	.1982	11000
7	.2450	11000
8	.2995	11000
9	.3460	.0465	478.7	19.6	9380
10	.3927	.0467	478.7	18.8	9000
11	.4394	.0467	478.7	18.0	8620
12	.4859	.0465	478.7	17.2	8230
13	.5318	.0459	478.7	16.4	7850
14	.5755	.0437	478.7	15.6	7470
15	.6180	.0425	478.7	14.8	7080
16	.6580	.0400	478.7	14.0	6700
17	.6954	.0374	478.7	13.2	6320
18	.7290	.0336	478.7	12.4	5930
19	.7445	.0155	478.7	12.0	5750
20	.7707	.0262	478.7	12.0	5750
21	.7854	.0147	478.7	12.0	5750

For a formula to determine the volume of the portion of a

spherical segment cut off by a plane at right angles to the base of the segment the writer is indebted to Professor Charles O. Gunther, of Stevens Institute. The formula is:

$$V = \frac{\pi a}{12} (a^2 - 3r^2) - \frac{b}{6} (3r^2 - b^2) \cos^{-1} \frac{a}{\sqrt{r^2 - b^2}} + \frac{ab}{3} \sqrt{r^2 - b^2} - \frac{a}{6} (a^2 - 3r^2) \sin^{-1} \frac{b}{\sqrt{r^2 - a^2}} + \frac{r^2}{3} \tan^{-1} \frac{r \sqrt{r^2 - b^2} - a^2}{ab}$$

where

- a = the perpendicular distance from the center of sphere to the base of the segment;
- b = the perpendicular distance from the center of the sphere to the cutting plane at right angles to the base of the sphere;
- V = 1/2 volume of the portion of the sphere cut off by the two planes.

To construct curves for general use, the tables shown for values of $\sqrt{r^2 - b^2}$, $\sqrt{r^2 - a^2}$, and $\sqrt{r^2 - a^2 - b^2}$ for $r = 100$, will be found very helpful.

TABLE II—VALUES OF $\sqrt{r^2 - a^2}$ AND $\sqrt{r^2 - b^2}$. $r = 100$

a	$\sqrt{r^2 - a^2}$	b	$\sqrt{r^2 - b^2}$
80	60.0	0	100.0
82	57.3	10	99.5
84	54.2	20	98.0
86	51.0	30	95.4
88	47.6	40	91.7
90	43.6	50	86.6
		60	80.0
		70	71.5
		80	60.0
		90	43.6

TABLE III—VALUES OF $\sqrt{r^2 - b^2 - a^2}$. $r = 100$

b	a = 80	a = 82	a = 84	a = 86	a = 88	a = 90
0	60	57.3	54.2	51	47.5	43.6
10	59.2	56.4	53.3	50	46.4	42.4
20	56.6	53.7	50.4	46.9	43.0	38.7
30	52	48.8	45.2	41.3	36.8	31.6
40	44.8	41	36.6	31.6	25.5	17.3
43.6	0	0
47.6
50	33.2	27.9	21	10
51	0
54.2	0
57.3	0
60	0

It will be noted that for use in figuring spherical end capacity for either Vanderbilt tenders or oil car tanks, a will rarely have values outside of .8r to .9r, whereas, b will vary between 0 and $\sqrt{r^2 - a^2}$. A curve may be plotted between these limits and intermediate values may be interpolated. To convert results to

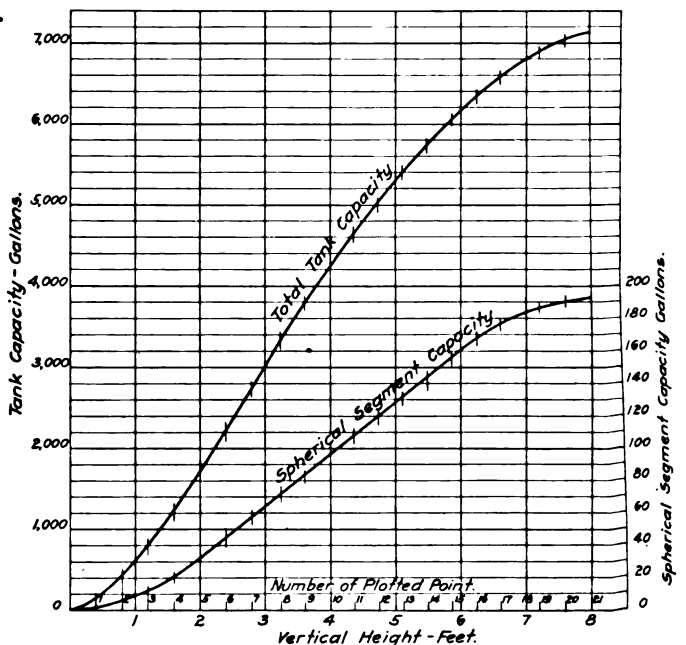

Fig. 3—Curve of Capacity for Vanderbilt Tank Shown in Fig. 1

gallons the readings taken from the curves should be multiplied by the cube of the radius of the sphere in inches and divided by 231,000,000.

In this manner were obtained the values for the capacity of the spherical end of the Vanderbilt tank, given in Table IV, and plotted in Fig. 3.

The third column of this table shows the results of the calculations indicated in Table I, and the last column gives the total

TABLE IV—CAPACITY OF VANDERBILT TANK

Point No.	Capacity Differences	Cylindrical capacity	Capacity of spherical end	Total tank capacity, gals.
1.....	...	162	2	164
2.....	...	450	6	456
3.....	...	813	12	825
4.....	...	1,224	21	1,245
5.....	...	1,690	33	1,723
6.....	...	2,180	46	2,226
7.....	...	2,696	58	2,754
8.....	...	3,296	72	3,368
9.....	436	3,732	84	3,816
10.....	420	4,152	97	4,249
11.....	403	4,555	109	4,664
12.....	383	4,938	121	5,059
13.....	360	5,290	133	5,423
14.....	327	5,617	145	5,762
15.....	301	5,918	157	6,075
16.....	258	6,176	168	6,344
17.....	236	6,412	178	6,590
18.....	199	6,611	184	6,795
19.....	89	6,700	187	6,887
20.....	156	6,856	191	7,047
21.....	85	6,941	193	7,134

capacity for each increment in depth of water, from which the total tank capacity curve in Fig. 3 is plotted.

These values, of course, are for a theoretical tank, as shown in Fig. 1, and make no allowance for baffle plates or for a rear end pocket to accommodate the draft gear. The baffle plates may be neglected, and if there is a draft gear pocket, it will have no effect on the net water readings unless the water in the tender is allowed to get extremely low.

RESULTS OF THE MASTER MECHANICS' ASSOCIATION LETTER BALLOT

Fifty-four subjects were submitted to the members of the American Railway Master Mechanics' Association for action by letter ballot, and of these only one was unfavorably acted on, that being the engineer's torch made of steel tubing and shown in the report of the Committee on Standardization of Tinware as Fig. 1. The entire 14 recommendations of the Committee on Standards and Recommended Practice were adopted, these including specifications for steel axles, firebox steel, forgings, cylinder castings, etc., and steel castings. The changes made in the specifications for inspection and testing of locomotive boilers to have them conform to the Federal regulations were adopted, as were the regulations covering the operation of brakes on engines and tenders handled dead in trains and offered in interchange.

The methods of photometering locomotive headlights, as proposed by the Committee on Locomotive Headlights, and the rules for determining stresses in longitudinal barrel seams and patches, longitudinal gusset braces and flat surfaces, and staybolts, radial stays and crown bar bolts in locomotive boilers as presented by the Committee on Design, Construction and Inspection of Locomotive Boilers, were also adopted.

Thirty-nine of the 40 examples of tinware presented by the Committee on Standardization of Tinware were adopted, which should prove of material assistance to the manufacturers and users of these articles. The instructions in fuel economy on locomotives, prepared by the Committee on Fuel Economy for the instruction of the enginemen and firemen were adopted, the vote lacking one of being unanimous. These instructions, it is understood, will be printed in pamphlet form and sold at a nominal cost by the association.

The three recommendations of the Committee on Forging Specifications covering the fiber stresses for heat treated and alloy-steel materials, and the specifications for quenched and tempered carbon steel axles and alloy-steel forgings (separate specifications) were adopted by a large majority. The rules outlined by the Committee on Boiler Washing for washing boilers were also adopted.

HOT TRAILER BEARINGS

BY G. W. A.

Hot trailer bearings are a source of much trouble to most motive power officials, as too frequently they occur on fast passenger trains, resulting in engine failures and annoying delays. The causes of hot boxes are either defective lubrication or excessive bearing pressure. Defective lubrication is induced by the following defects: (1) Waste improperly applied, (2) insufficient oil or oil of poor quality, and (3) too little waste or a poor quality of waste. Excessive bearing pressure may be due to (1) poor design, (2) improper application of the brass or (3) broken spring rigging.

Eternal vigilance is the only complete safeguard. In applying waste to the cellar care should be taken to see that it is long fibered, well saturated with oil, preferably coach oil, and so worked into the cellar as to present a uniform mass of intertwined fibers. If the axle has a collar, the waste should be packed so that it will not be tight against the collar, as the latter acts as a wiper, glazing the surface and forming a productive source of future overheating. On one large system in an effort to eliminate hot trailer bearings a very rigid system of inspection is practiced in the roundhouse. A record is kept of each engine and every four days the cellar is taken down,

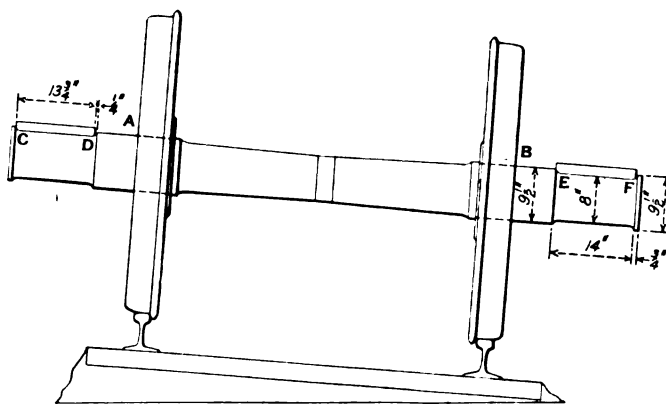

Ends of Trailer Braces in Contact with Shoulders When Curving

the waste worked over, a slight amount of fresh dope added and the box oiled, or the whole renewed as the case may be. Notwithstanding this care, however, hot trailer bearings are of too frequent occurrence, which leads to the belief that they arise from other causes.

The sketch shows the type of journal and brass on a class of Pacific type locomotive used in both passenger and fast freight service. This trailer is of the radial type, using a roller bearing plate for the spring seat. The total wheel load carried is 40,500 lb., of which about 4,500 lb. represents the weight of the wheels and axle, leaving 36,000 lb. to be distributed between the two journals. This gives a bearing pressure of 191 lb. per sq. in. of projected area, well within the limit of safe practice. The axle used is of the collar type, and to this it is believed can be attributed in many cases the beginning of heating. It has been noted in a number of instances that heating is first observed about the collar, and when discovered in time may be checked. While not accessible, it is also believed that the shoulder adjoining the wheel seat acts in the same manner, but owing to the larger body of metal in close proximity, more heat is conducted away, and the bearing is therefore heated less rapidly. Signs of heating and of cutting are in practically all cases found on both the fillet of the collar and the shoulder at the rear end where bearings have been overheated. The distance between the collar and shoulder of the axle is 14 in., and the length of the brass is 13 3/4 in., giving a clearance of 1/4 in. When in the shop, or when new hub liners are applied, the trailer is fitted up with a total lateral motion

of $\frac{1}{4}$ in. Assume now, that the engine is rounding a curve as shown in the sketch. Pressure is exerted against the wheel flange, tending to throw the hub face *B* in contact with the liner on the truck box. With $\frac{1}{4}$ in. total side play, this motion will only amount to $\frac{1}{8}$ in., still giving $\frac{1}{8}$ in. clearance between collar or shoulder and the end of the brass. When, however, the lateral has worn to a total of $\frac{1}{2}$ in., the side movement induced in rounding the curve will not only cause contact with the box and hub at *B*, but also between the journals and brasses at *E* and *C*. From this time on, as side play develops the box and brass will both wear. If now, the lubrication at any time is momentarily impaired, or the waste around the collar has become glazed, the fillets will tend to cut and heat the ends of the brasses against which they are thrown in rounding curves. Should the brass for any reason be renewed after a total side play of more than $\frac{1}{2}$ in. has developed, the above condition is greatly aggravated. In this case the side play for the brass is only $\frac{1}{4}$ in., and the thrust in turning the trailer must be carried by the small fillet bearing on the end of the brass instead of by the liner.

The force exerted on a trailer in rounding a curve may be considered as the centrifugal force acting on the load carried by the truck and the frictional resistance between the wheel and the rail. The centrifugal force is resisted by the hub face on the low side of the curve, by the frictional resistance in the spring roller plates or step bearings and by the centering springs. For purpose of illustration let us assume that the engine is rounding a 2 deg. curve at 50 miles per hour, and consider only the centrifugal force acting on the truck:

$$\text{Centrifugal force} = \frac{40,500 \times 73.4^2}{32.16 \times 2,865} = 2,364 \text{ lb.}$$

The area of the hub plate is 148.814 sq. in., while the projected area on the end of brass is 6.872 sq. in. The bearing pressure produced on the hub plate is $\frac{2,364}{148.814} = 15.92$ lb. per sq. in., while that produced on the ends of the two brasses is $\frac{2,364}{2 \times 6.872} = 172$ lb. per sq. in.

It will thus be seen that it is entirely possible to have an excessive collar bearing pressure, which in conjunction with defective lubrication at this point, may be a source of overheating. It is the writer's belief that the collars should be abandoned and the shoulders so located as to insure ample clearance between them and the ends of the brasses at all times.

ABATEMENT OF LOCOMOTIVE SMOKE IN CINCINNATI*

BY G. H. FUNK

General Smoke Inspector, Cincinnati Railway Smoke Inspection Bureau

The elimination of smoke in the city of Cincinnati is an especially difficult proposition, as that part of the city where many of the yards are located and the greatest congestion occurs lays in a valley; climatic conditions are also such that the smoke nuisance is considerably aggravated. In several instances there are heavy grades just outside the depot or yards, which require the locomotives to be operated to their full capacity. One road has an ascending grade of $3\frac{1}{2}$ per cent for $1\frac{1}{2}$ miles from the start. In order successfully to combat the smoke under these conditions it is necessary that the locomotives be in good condition, properly equipped with adequate smoke consuming devices, and most of all, that the engine crews be well trained in their respective duties.

In July, 1913, the railroads took concerted action to combat the smoke problem and organized the Railway Smoke Inspection Bureau. The inspectors attached to this bureau are responsible

only to the bureau, and make impartial observations of all locomotives coming within their notice, reporting the results to the general inspectors. All violations are reported daily to the officer of the road on which they are made, and weekly reports are made to each road showing the total number of engines observed, the number of violations and the comparison with the previous week. The inspectors do not confine themselves to making observations, but make it a point to ride with the offending engine crews at the first opportunity to find out what is wrong. They are able as practical engine men to instruct the crews in the proper method of handling the locomotives. Where the engine is found at fault a report is made to the proper official at once. At certain intervals the inspectors ride every engine and with every crew at the terminal, and repeat the instructions, demonstrating by actual operation what can be accomplished.

By reporting the condition of the engine, as well as the smoke violation, there has been a noticeable improvement in the condition of the locomotives. Monthly meetings are held with the master mechanic, general foreman, road foreman of engines and others interested. The subjects discussed are diversified, extending from drafting of engines to the chemistry of combustion. The meetings have been found to be of great value.

Some roads have distributed instruction books to their men on the elements of combustion of fuel, covering the ground sufficiently to show how smokeless firing may be obtained, and the economy in fuel that will result. The engineers are not neglected. They are instructed as to the proper methods of operating the locomotives and are required promptly to report all defects, such as blows, plugged flues, leaky joints, or any other cause that may make the engine steam badly. As most of the roads use a high volatile bituminous coal, it was found necessary to equip the locomotives with some device to assist in the abatement of the smoke. The induction air tubes, brick arches, double or multiple tip blowers, and openings in the fire-box have been adopted as standard, producing excellent results. Attention has been given to the admission of the air through the ash pans and grates, and on many engines that formerly had tight ash pans, the pans have been dropped from 3 in. to 5 in. from the mud ring, the openings being covered with screens. Most of the roads have found it possible to enlarge the nozzles without effecting the steaming of the engine. By doing this the back pressure in the cylinder has been reduced and a milder draft is obtained, which permits the fireman to keep the fire thinner; the tendency towards the formation of holes, due to excessive draft, has also been reduced. One road has increased the size of nozzles from $4\frac{1}{8}$ in. to $5\frac{3}{4}$ in., resulting in a fuel saving of 17 lb. per engine mile.

Before the locomotive leaves the engine house territory the fire is supplied with sufficient fuel, admitted in small quantities to avoid smoke, until there is a moderately heavy bed of coked coal over the entire grate surface. In switching service not more than two scoops can be fired at a time. In freight pusher service the charges are limited to three scoops at a time; in light passenger service two scoops is the limit, and in heavy service, three scoops. The engine crews are instructed to bring their engines to the ash pit with no green coal in the fire-box and with a well-burned fire.

The Railway Inspection Bureau averages from 750 to 800 observations per week. The average smoke density has been decreased from 30.8 per cent in November, 1913, to 15.4 per cent in August, 1915. In addition to the excellent results from reducing the smoke there has been found to be an improvement in the fuel economy. One road with the side induction tubes, the long arch and the larger nozzles on its locomotives, has been able to show a saving of 102 lb. of coal per engine hour, and a superintendent on another road claims a saving of 13 per cent in fuel. The greatest factor, however, in any smoke abatement campaign is the engine crew, and it will be found that a good fireman on a poorly equipped locomotive will produce less smoke than a poor fireman with all the latest appliances.

*Abstract of a paper presented before the tenth annual convention of the International Association for the Prevention of Smoke.

CAR DEPARTMENT

CLEANING CARPETS AT TERMINALS

The method of cleaning carpets at the car yards of the Chicago & Western Indiana, a terminal company at Chicago, is shown in the illustration. Compressed air is used. The arrangement shown at the left is for cleaning or blowing the dirt out of the aisle strips. It consists of two guide rods and a pipe with perforations on its under side. The carpet is passed over one guide rod, under the perforated pipe and out over the other guide rod. The arrangement is simple and cleans the aisle strips thoroughly. The method of cleaning the larger pieces of carpet is shown at

formulated by the Committee on Car Construction was adopted with a large majority, and, if carefully followed, will be of material benefit to the railroads. The entire recommendations of the Committee on Specifications and Tests for Materials were adopted. The work of the Committee on Train Lighting was approved, with the exception of the recommendation regarding the use of emergency fuses between the dynamo and field on wooden cars equipped with axle dynamos. The Committee on Car Trucks, acting on the suggestion of those roads which voted negatively on the subjects submitted to letter ballot at the 1914 convention, has succeeded in reconstructing its recommendations

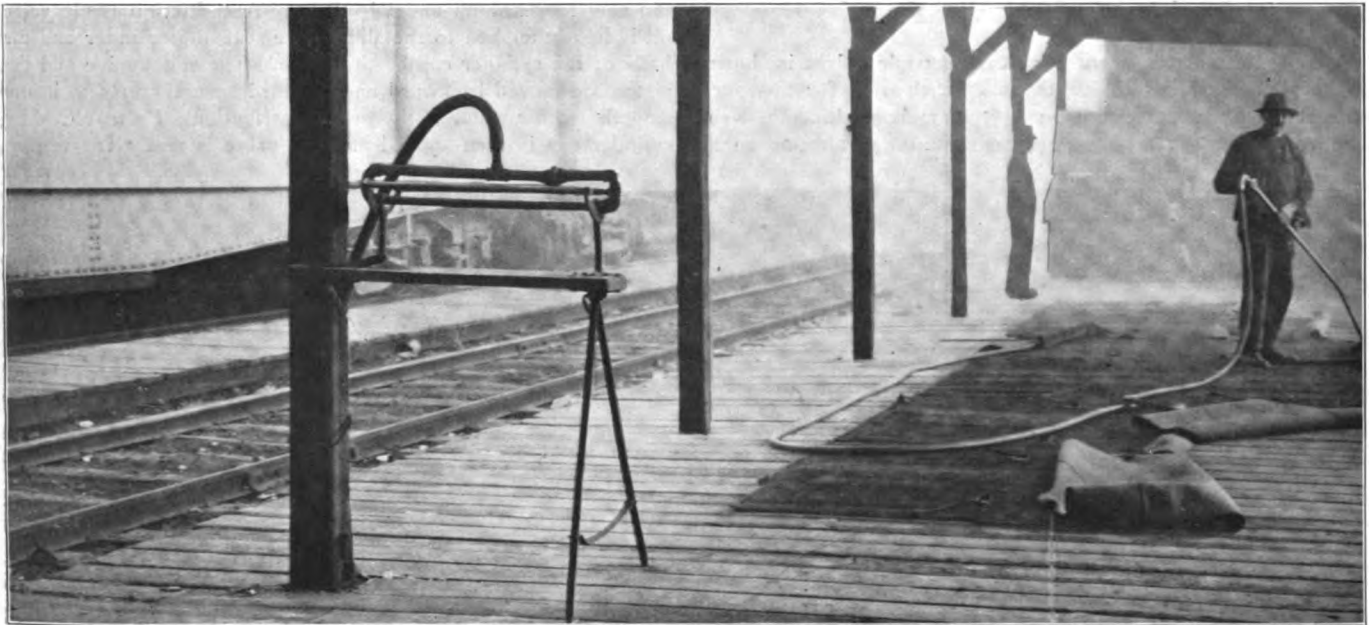

Apparatus Used for Cleaning Carpets by Compressed Air on the Chicago & Western Indiana

the right. Air from the short line is used in both cases, the water being thoroughly blown out of the apparatus and pipes before using.

RESULT OF M. C. B. LETTER BALLOT

Of the 91 subjects submitted to the members of the M. C. B. Association for adoption by letter ballot only five were rejected. Of those rejected the specification describing the door of wooden construction and the question as to whether or not standards should be established for limiting dimensions for the cast steel design of truck side frames, with pedestal jaws and designs of journal boxes for them, were the most notable. The Committee on Brake Beams succeeded this year in providing a specification for testing all classes of brake beams that was adopted by a large majority. The adoption of the recommendation of the Committee on Train Brake and Signal Equipment, that truck clasp brakes be applied to all four-wheel truck passenger cars weighing 96,000 lb., or over, and to all six-wheel truck passenger cars weighing over 136,000 lb., is indicative of the success of this type of brake.

The rules governing the minimum strength requirements for reinforcement of the draft gear of existing wooden cars, as

so that 17 of the 18 subjects presented this year were approved. Following is a list of the subjects voted on:

Standards and Recommended Practice:	
Hole in wedges for removal by use of packing hook. (Standard)	Adopted
Lining for outside framed cars	Adopted
Springs and spring caps for trucks. (Standard)	Adopted
Classification of cars	Adopted
Height of platform buffer for passenger cars	Rejected
Postal car specifications and floor plans	Adopted
Insulator tests	Adopted
Uncoupling arrangements for passenger car couplers	Adopted
Omission of arc recess in wedges	Adopted
Train Brake and Signal Equipment:	
Conductor's valve	Rejected
Truck clasp brakes	Adopted
Hose coupling gasket gage	Adopted
Brake Shoe and Brake Beam Equipment:	
Specifications and tests for brake beams	Adopted
Loading Rules:	
Rules 4, 12C, 15A, 15B, 15F, 24, 93, 96, 98B, 120, 121B, 124, 124A, 126, and 130	Adopted
Car Construction:	
Specifications for side doors for new cars. Paragraph 4a)	Rejected
Specifications for side doors for new cars. (Par. 4b to 4n, inclusive)	Adopted
Draft gear. Par. 6a to 6d, inclusive)	Adopted
Shearing value of steel	Adopted
Specifications for Tests of Materials:	
Changes in chain specifications	Adopted
Changes in coupler specifications	Adopted
Changes in steam heat hose specifications	Adopted
Changes in air brake hose specifications	Adopted
Specifications for structural steel, etc. (passenger cars)	Adopted
Specifications for structural steel, etc. (freight cars)	Adopted
Specifications for malleable iron	Adopted
Specifications for miscellaneous steel castings	Adopted
Specifications for journal bearings	Adopted
Specifications for mild steel bars	Adopted
Specifications for rivet steel and rivets	Adopted

Specifications for galvanized sheets.....	Adopted
Train Lighting:	
Dynamo fuses on wooden cars.....	Rejected
Minimum dimensions for battery boxes.....	Adopted
Armature pulley.....	Adopted
Armature shaft end.....	Adopted
Pulley taper fit.....	Adopted
Ball bearing size.....	Adopted
Conduits.....	Adopted
Solid face generator pulley.....	Adopted
Car Trucks:	
Specifications and tests for cast steel truck sides.....	Adopted
Specifications and tests for pressed steel bolsters.....	Adopted
Variations in weights of truck sides.....	Adopted
Rejection of cast steel truck sides.....	Adopted
Design of cast steel bolsters. (Exhibits C to H, inclusive).....	Adopted
Design of pressed steel bolsters. (Exhibits I, J, and K).....	Adopted
Limiting weights for cast steel bolsters.....	Adopted
Limiting weights for pressed steel bolsters.....	Adopted
Spread of side bearings.....	Adopted
Center plates.....	Adopted
Truck sides with pedestal type jaws.....	Rejected

A more detailed account of the propositions submitted to the members in this letter ballot may be found under the reports of the respective committees which were abstracted in the *Daily Railway Age Gazette* of June 10, 11, and 12, 1915.

CLEANING TRIPLE VALVES

A convenient arrangement for cleaning triple valves is shown in the photograph, which illustrates a bench used for this purpose at the Chicago, Burlington & Quincy shops, Lincoln, Neb. The work is done on a piece-work basis and the arrangement was

piston and slide valve are removed and the piston dipped in kerosene oil in the can *A* and allowed to drain. The check case is then removed, the brace *D* being used for this purpose. The emergency valve is removed and placed in the basket *K*. The valve body is then blown out with the air hose *C*. The gasket is removed and the seat scraped. The body is swabbed out with kerosene and wiped dry. The emergency piston is blown out and carefully wiped, its seat being slightly ground on the sandpaper at *G*. The emergency piston and valves are then replaced after the rubber seat of the valve has been smoothed off by sandpaper and replaced. The check valve case is then placed in the rest *F* and the check valve is ground to a seat with the brace *E*, the pumice and oil mixture being already prepared at *I*. It is then carefully wiped out with a cloth. The check case is placed over the nozzle *H*, the pipe opening being inserted in the pipe there shown and blown out. Air for this purpose is controlled by a pedal valve under the bench. The check case with the check valve is then replaced.

The main piston which has been draining at the can *A* is then cleaned, the oil being blown out from under the packing ring, the ring loosened up and wiped dry. Anti-friction triple valve oil is lightly applied to the slide valve seat, the cylinder and the head of the cylinder cap by the finger. The slide valve and the piston are moved backward and forward several times to insure smooth working and a thorough distribution of the oil. The cylinder cap is then applied and the valve is ready for testing.

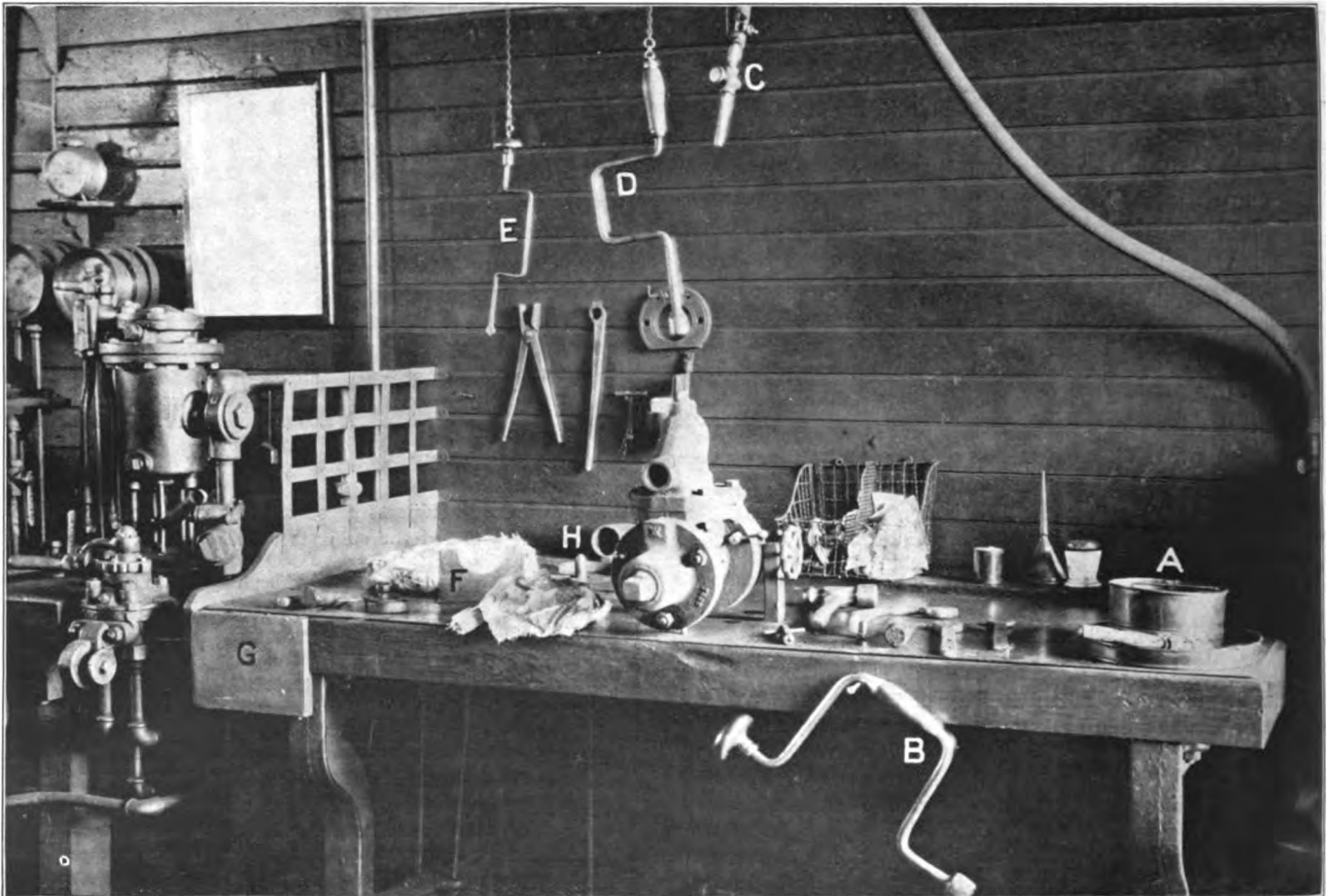

Arrangement of Bench for Cleaning Triple Valves

planned by the men doing the work. The valve, which in this case is a Westinghouse H triple, is first placed in the holder as shown. The cylinder cap nuts are touched up with kerosene oil with the brush shown at *A*, the oil being contained in the can, and the nuts are removed with the brace *B*. The cylinder cap is then removed and blown out with the air hose *C*. The main

With these conveniences it is possible to clean a triple valve in from six to seven minutes.

SWEDISH IRON IMPORTS.—Swedish imports of pig iron were only 35,660 tons for the first six months of 1915, compared with 47,894 tons in the same period in 1914.—*The Iron Age*.

FOUR WHEEL TRUCKS FOR PASSENGER CARS*

Discussion of Fundamental Factors of Design and the Ability of This Type of Truck to Meet Them

BY ROY V. WRIGHT

The Pennsylvania Railroad uses four-wheel trucks under all of its passenger coaches, although the P 70 class, 70 ft. in length and having a seating capacity of 88, weigh light from 118,000 to 122,000 lb. Loaded with passengers they weigh about 135,000 lb., and never more than 140,000 lb. It is the standard practice on that system to use such trucks under **all** passenger equipment cars weighing less than 120,000 to 125,000 lb., except for so-called load-carrying cars, including baggage-express, mail, baggage-mail, etc., which are designed to weigh over 140,000 lb. when loaded. The light weight of the bodies of the Pennsylvania P 70 coaches—and these are now standard on that system—varies from 93,000 to 96,000 lb. It is assumed that these cars regularly carry as much weight in passengers and hand baggage as coaches on other roads, inasmuch as they seat 88 persons, or several more than the maximum provided for in the standard coaches of most roads. It is the practice on the great majority of railroads to use six-wheel trucks under coach bodies weighing much less than this, comparatively few roads using four-wheel trucks under bodies weighing more than 85,000 lb. and many of them using six-wheel trucks under bodies weighing even less than this.

FACTORS IN DESIGN

In designing the trucks for a passenger coach four features must be kept in mind and generally in the following order as to importance, although there may be some question as to the relative value of the last two:

- (1) They must be designed for safety.
- (2) They must ride smoothly, for travelers are particular as to this in these days and will desert a road with rough-riding cars if a competitor furnishes better service. With heavy steel cars operated in long trains at high speed and with the locomotives taxed to the limit of their capacity it is difficult to operate and brake the trains without occasional roughness and jolts, and a factor such as truck design cannot be allowed to contribute further to the rough riding.
- (3) The weight of the truck must be kept to a minimum if for no other reason than the effect on the cost of conducting transportation.
- (4) The truck should be designed with a view to keeping the cost of maintenance as low as possible. Here, as in the requirement for safety, it is desirable to have as few parts as possible and of simple construction.

DOES THE FOUR-WHEEL TRUCK MEET THESE REQUIREMENTS?

How does the four-wheel truck meet these requirements under the heavy passenger equipment in service on the Pennsylvania Railroad?

(1) The four-wheel truck of modern steel construction which has been in use on that system for a number of years has given splendid satisfaction so far as safety is concerned. As on other roads some trouble has been experienced with hot boxes, and it was at first thought that the journal-bearing area was too small. The use of larger bearing areas does not seem to have materially improved conditions, and it is now believed that the difficulty is entirely due to dirt or gritty matter entering the journal boxes. The problem then becomes one of improving the journal box lid and dust guard to prevent this, rather than to increase the diameter or length of the journals.

There has been no breakage of axles except for three cases

due to defective material when the first steel trucks were introduced many years ago. No physical weakness has developed in any of the parts in the ten years the trucks have been in service, so that as far as safety is concerned there can be no question. The possibility of accident would seem to be less with the four-wheel truck because of the smaller number of parts that are required.

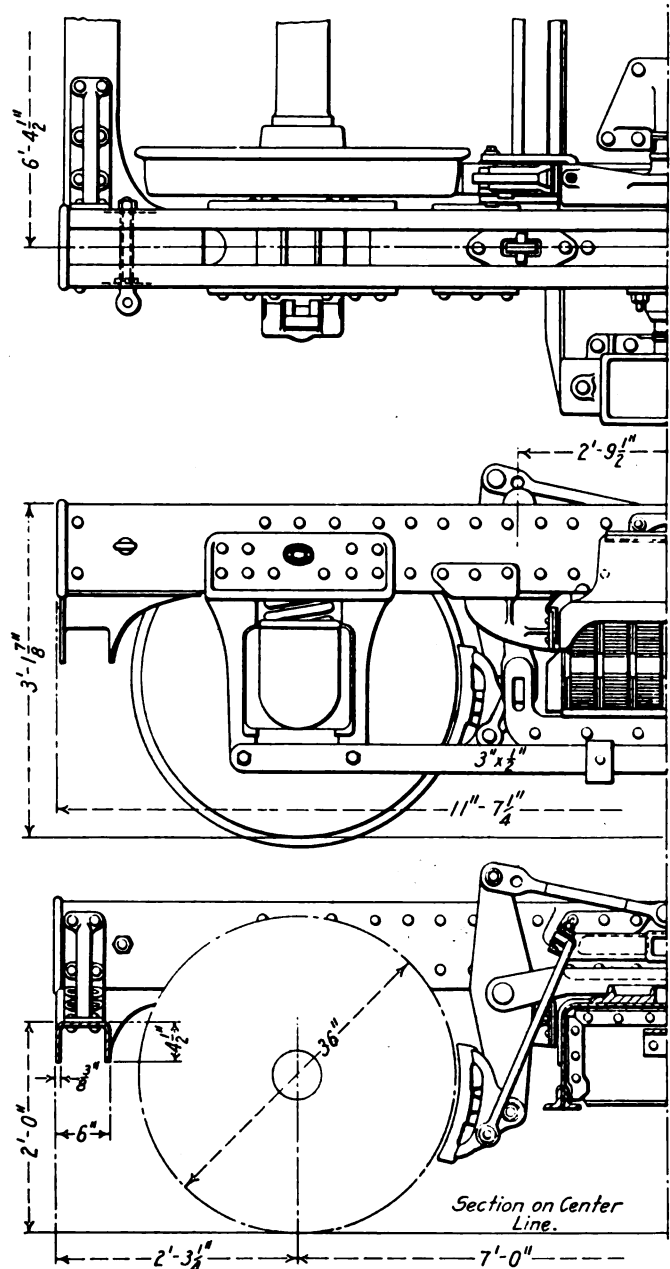

Fig. 1—One End of Original Four-Wheel Steel Passenger Car Truck Before the Application of the Clasp Brakes; Pennsylvania Railroad

(2) There seems to be a feeling on the part of some mechanical engineers that the four-wheel truck, with its shorter wheel base (7 or 8 ft. as compared with 10 to 11 ft. for the six-wheel truck) will ride less easily than the six-wheel truck. With coil springs over the journals, elliptical springs under the

*A paper to be presented before the December, 1915, meeting of the American Society of Mechanical Engineers, New York.

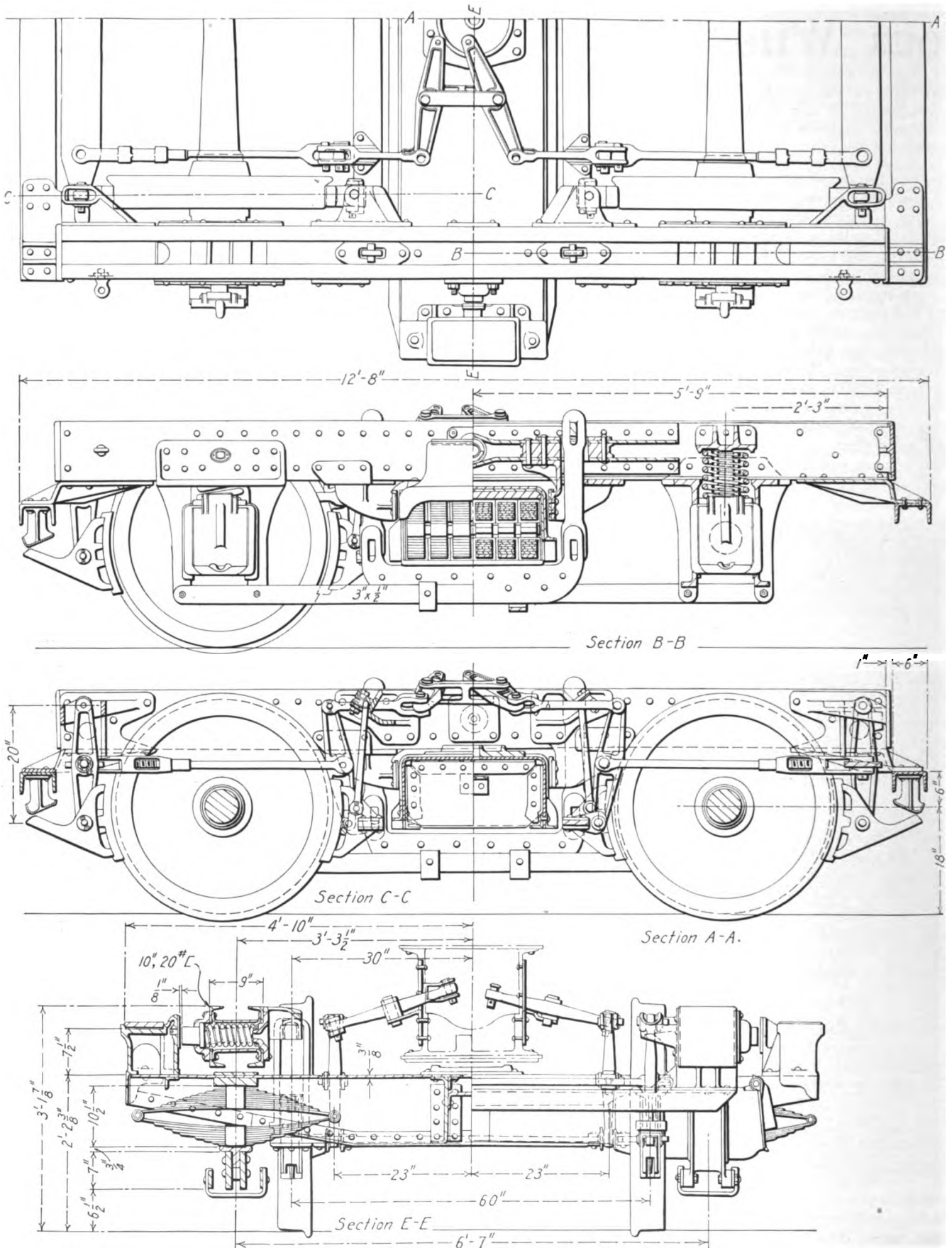

Fig. 2—Original Four-Wheel Steel Passenger Car Truck with Clasp Brakes Applied; Pennsylvania Railroad

bolster, and provision for lateral motion of the bolster, it would seem that there ought not to be much difference in this respect.

Experiments show that much of the rough riding or jolting on passenger coaches has been due to the method of anchor-

ing the top of the dead lever to the truck frame. The unbalanced forces in the truck when the brakes are applied tend to tilt the truck frame out of horizontal alinement, thus causing a "jerky" action. By anchoring the dead lever to the body under-

frame this is eliminated. This development is comparatively recent and affects the six-wheel as well as the four-wheel truck. The effect of anchoring the dead lever to the truck frame has possibly been more noticeable on the four-wheel truck, because

(3) There is a wide variation in the weights of different types of steel passenger car trucks, but it is probably fair to state that a pair of four-wheel trucks will weigh from 10,000 to 15,000 lb., or more, less than a pair of six-wheel trucks having

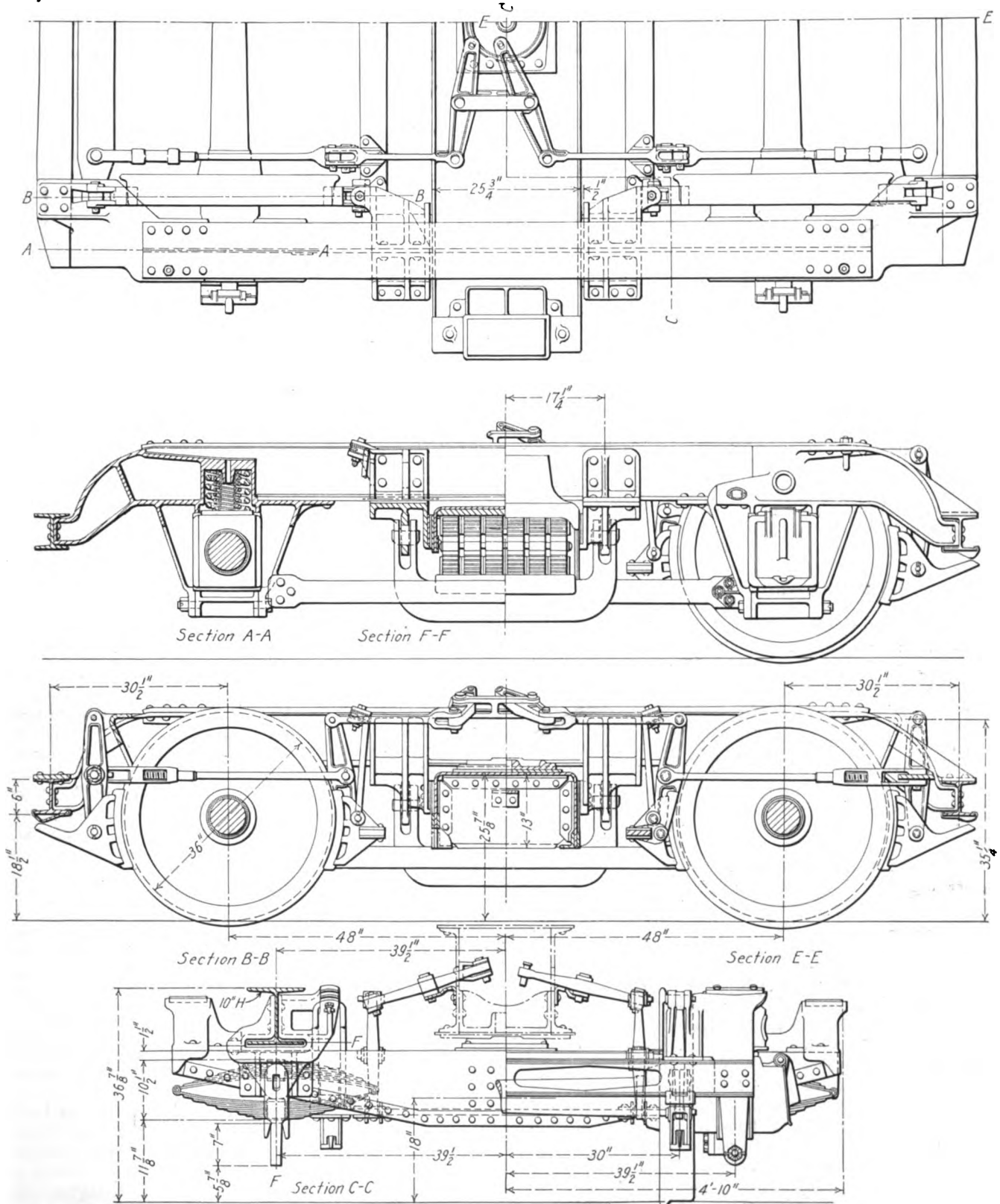

Fig. 3—Present Standard Four-Wheel Steel Passenger Car Truck; Pennsylvania Railroad

one to one dead levers are used, resulting in a greater pull on the frame than in the case of the six-wheel truck; then, too, the resisting moment is less because of the shorter wheel base of the four-wheel truck. This improvement has been patented.

the same carrying capacity. In other words, for the same total weight of car the one with four-wheel trucks will carry ten to fifteen thousand pounds more lading or body weight, or with the same weight of body the total weight of the car with four-

wheel trucks will be from 10,000 to 15,000 lb. less than the one with six-wheel trucks. For a car weighing 120,000 lb. and equipped with four-wheel trucks this means a saving of from 8 to 11 per cent in total weight as compared with what it would be if six-wheel trucks were used. On most roads it is the practice to carry car bodies weighing more than 85,000 lb. on six-wheel trucks, which weigh fully 15,000 lb. per car more than four-wheel trucks. A locomotive that can haul eight cars equipped with such six-wheel trucks over a given division will haul nine cars of the same seating capacity having four-wheel trucks—a saving much to be desired.

(4) Roughly speaking, the cost of maintenance of a steel passenger car truck may be said to be very nearly in proportion to the number of its wheels and axles, these with the brake shoes being the parts subjected to the greatest wear and requiring frequent repairs and renewals. While no exhaustive data is available as to the comparative cost of repairs and maintenance of six-wheel and four-wheel trucks of the same carrying capacity, they are said by those who have checked these costs to be at least 50 per cent greater for the six-wheel truck than for the four-wheel truck.

DEVELOPMENT OF PENNSYLVANIA FOUR-WHEEL TRUCK

As a partial check on these conclusions, it is proposed to briefly review the development of the four-wheel steel truck for passenger cars on the Pennsylvania Railroad. From the outset and throughout this development the aim has been to reduce the number of parts to a minimum and make the construction as simple as possible. The problem has been complicated somewhat by the necessity of providing for the application of motors to the trucks used under motor cars in electrified districts and also by the application within the past few years of the clasp brakes, which are now standard on the Pennsylvania for all four-wheel trucks and for all new passenger equipment trucks.

In designing the first four-wheel steel trucks in the early part of 1905 it was aimed to use them under the largest coach possible and keep within the M. C. B. load limits for 5-in. x 9-in. axles. Shortly after the trucks had been placed in service three of the axles broke in the wheel seat, where the stress is least. Investigation finally showed that the breakage was due to defects in manufacturing caused by a faulty furnace which had been discarded shortly after these axles were made. In the meantime, however, as a measure of absolute safety, it was decided to increase the axles on existing cars $\frac{1}{2}$ in. in diameter and on new cars go to the next larger size standard M. C. B. axle, the $5\frac{1}{2}$ -in. x 10-in. Because of hot box troubles the length of journal was afterward increased in 11 in., although experience has since indicated, as previously noted, that the trouble was probably due more to dirt getting into the journal box than the lack of journal bearing area. The $5\frac{1}{2}$ -in. x 11-in. journal is now standard for all four-wheel as well as six-wheel trucks.

In going from the wood to the steel construction spring planks, axle guards and brake beams were done away with, the brake levers being attached directly to the brake heads. Each side frame was formed of two 10-in. 20-lb. channels, with the flanges turned inward and forming a box girder construction. The channels were spaced so as to measure 9 in. over-all. This was done to provide sufficient strength for resisting the lateral stresses, a requirement which has been overlooked in some designs. To check or limit the lateral motion or swaying of the bolster a spring arrangement was used, as shown in the drawing.

The subsequent use of clasp brakes made it necessary to modify this design somewhat. Fig. 2 shows the details of this modified design, which in general is practically the same as the original design, other than the braking arrangement, except for changes in the end construction of the frame to provide for the outside brakes. The detail of the original end con-

struction is shown in Fig. 1. The end rail in the original design, which was formed of a $\frac{3}{8}$ -in. plate pressed in the form of an inverted U, 6 in. in width, was changed to make room for the brake levers. The outside brakeheads in the case of the clasp brakes are attached to the lower ends of the brake levers, which are anchored at the top to castings riveted to the ends of the side frames. A 6-in. channel with flanges turned downward connects these castings and forms the end rail. It was also necessary to add brakehead tie bars because of the impossibility of connecting the tension rods for the outer brakeheads direct to the brake lever. It should be noted, however, that this brakehead tie bar is a simple rectangular bar and that the brake tension rod connects to it as close to the brakehead as possible. Obviously the weight and the cost of maintenance of this tie bar is much less than for a breakbeam where the force is applied at the middle. All of the brake levers, including both the dead and live levers, are made the same size and are interchangeable except for the drilling.

The peculiar form of the outer brakehead is noticeable. In the first application of the clasp brakes the ordinary type of brakehead was used with springs to hold it balanced when hanging loose. These springs were difficult to maintain and were done away with by redesigning the brakehead and adding the tail piece. When the brakehead hangs loose this tail piece rests against a casting which is riveted to the underside of the end rail. When the brake is applied there is a clearance of $\frac{1}{2}$ in. between the brakehead tail piece and the rest. This device has given most satisfactory results.

The next development was a modification of this design to provide for the application of a motor for use under motor cars on electrified divisions. To do this it was found necessary to increase the wheel base from 7 ft. to 8 ft. 6 in. Transoms were also added to support the lip of the motor and the bolster design was modified slightly; otherwise the same parts were used as in the original design.

The next development was a radical one, the box girder sideframe being replaced by a Bethlehem 10-in. 54-lb. H-beam, thus simplifying the design as to construction by reducing the number of parts and still providing sufficient moment to resist the side stresses. As shown in Fig. 3, the journal box pedestal casting has a projection to which the top of the lever for the outside brake is anchored and which also supports the end rail, a 6-in. H-beam. The H-beam which forms the side frame has its lower flange and web cut away over part of the journal box pedestal casting and is strongly riveted to it through both the upper and lower flanges. The casting which was formerly used on the end rail to balance the brakehead was replaced by a steel clip which is sprung over and welded to the lower flanges of the end rail.

Another noticeable change was the shortening of the bolster hangers, thus limiting the amount of side swing and making it possible to do away with the complicated spring mechanism which was formerly used to check and limit the lateral motion of the bolster with the longer hangers. Before making this change the springs were gradually blocked and finally wedged solid on a number of the cars. As this had no noticeable effect on the smooth riding, it was decided to discard the springs entirely.

The more important of these changes, that is, the side frame construction and the change in the hanging of the bolster, were first made on four-wheel trucks for suburban cars, several hundred of which were built. These trucks, however, were of lighter construction than those used under the standard coaches and will not be considered in this discussion. The details of this improved truck as designed for use under standard coaches are shown in Fig. 3.

A modification of this standard truck was made necessary by the Philadelphia-Paoli electrification and is shown in Fig. 4. The most powerful motors thus far used under passenger

coaches are required in this service, 225 horsepower each. To provide for them it was necessary to extend the wheel base of the truck from 8 ft. to 8 ft. 8 in. Because of the great amount of room required by the motors, blower apparatus, etc., it was necessary to do away with the brakelhead tie-bars, or brakebeams, and to arrange the tension rods for the outside brakeheads to straddle the wheel as shown in the drawing. This application also made it possible to change the construction at the ends

and the gear wheel, which meshes with the motor pinion, is now fastened to the axle rather than on the projection of the wheel hub.

It is necessary to provide a blower apparatus to cool the large motors which are used. The blowers are fastened to the underframe of the body of the car near the center and the draft is carried through a duct formed by the box-shaped center girder of the car between this point and the bolster.

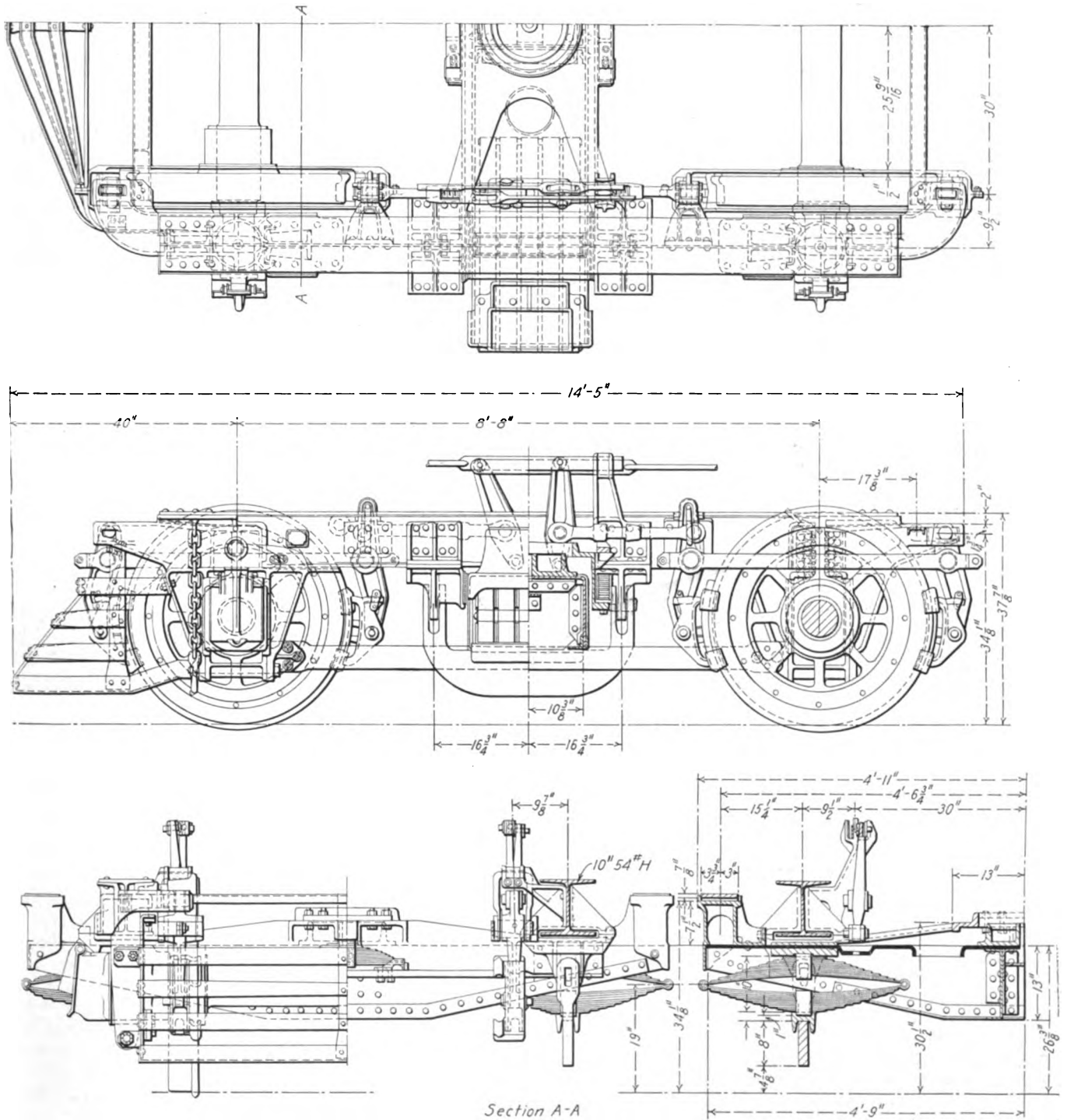

Fig. 4—Standard Four-Wheel Steel Passenger Car Truck Modified for Use Under Motor Cars on Electrified District of Pennsylvania Railroad at Philadelphia

of the side frames and the end rail. The details of this design are presented in order to show how the four-wheel standard truck for use under heavy coaches could be preserved in its general features and be arranged for use under the heavy modern electric motor cars. The drawing shows the use of spoke wheels. Recent practice has changed these to plate wheels,

From the latter point a duct extends laterally from each side of the center girder, delivering the air where it is needed. The motor leads pass through holes in the truck bolster close to the center plate so that the curving of the truck creates the least possible amount of distortion in the leads. Fortunately the necessity for making some such provision was foreseen a

number of years ago and it has not been necessary to make any important modifications in the design of the truck bolster.

THAWING OUT FROZEN CARS

The illustration shows the interior of the thawing-out house of the Chicago & Western Indiana at Chicago, used for thawing out the cars. The house is about 175 ft. long and 34 ft. wide, and contains two pits in which heating pipes are located. About 2,400 sq. ft. of heating surface is provided, which with a steam pressure of 50 lb. will, in about three hours, give a temperature of 110

sitions show both, and it is difficult for the person doing the purchasing to know what to obtain.

Don't forget to state in all cases where surface lumber is ordered, just what sides and edges are to be surfaced. Calling for it as dressed, finished or surfaced, without stating how this is required, is like calling for boards and giving no dimensions.

Where grades are not known by those ordering the lumber the purpose for which the lumber is to be used should be stated on the requisition, as this will give the purchasing department an opportunity to determine the grade desired. This point should be given careful consideration as it may save unnecessary expense to the company in the course of a year.

The following methods will prove satisfactory for storing

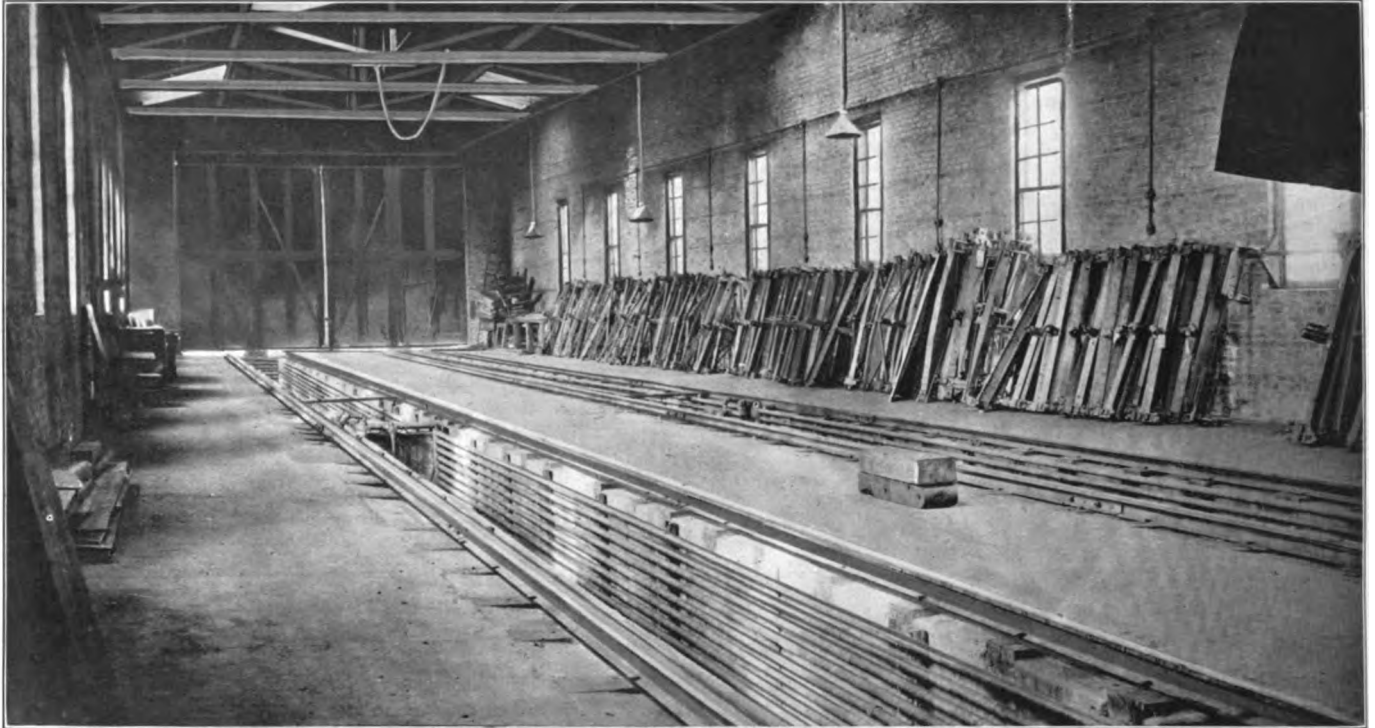

Interior of Thawing House, Chicago & Western Indiana

deg. Fahr. during the coldest weather. For cars that are generally frozen up this house has proved invaluable, especially during the severe winter of 1911-1912.

ORDERING AND HANDLING LUMBER

At a meeting of the storekeepers, mechanical and operating officers of the Atchison, Topeka & Santa Fe, at Albuquerque, N. Mex., September 26, 27 and 28, a number of interesting papers were read on the general subject of storekeeping. The following is taken from a paper presented by T. O. Wood, purchasing agent of the Gulf, Colorado & Santa Fe, at Cleburne, Tex., on the subject of "Suggestions as to the Proper Manner of Ordering Lumber":

Don't order all lumber 16 ft. long. About seven-eighths of the orders on the mills call for 16-ft. lumber, and if the requirements are made in lengths of 12, 14, 16, 18 and 20 ft., they could be filled by the mills in less than half the time than if the entire order was for only 16-ft. lumber.

Don't order any length longer than 20 ft. if two shorter lengths will do, as all lengths over 20 ft. cost additional, the cost varying about \$1 per thousand for every 2 ft. over 20 ft.

Don't order boards 12 in. wide if smaller widths will do, as the price increases above 8 in. in width. In ordering surface lumber for building, if possible order all lumber in rough sizes, or all in finished sizes, the latter much preferred. Some requi-

lumber: All stacks should be from 2 ft. to 3 ft. above the ground to allow free circulation of air and they should be pitched one inch per lineal foot. Each piece should be exactly over the piece underneath it, and from 1 in. to 1½ in. apart from the pieces on each side for 4 in. lumber. This space should be increased up to 3 in. or 4 in. for lumber up to 12 in. wide. The cross pieces should be the same as the material to be stored when lumber and timber 1 in. to 4 in. thick is used. For 6 in. timber, and over, this plan would run the stack too high, and 1 in. or 2 in. strips of waste lumber can be used. These cross pieces should be placed on every layer, about 4 ft. apart, and the front pieces should project ½ to ¾ in. over the ends to protect the stack from the sun and rain. When the stack is completed one piece of the material used in the stack should be placed over the space between each tier. Some saw mills put an air space 12 in. wide in the center of the stack, which they call a flue. Others do not. Probably this is a matter which should be regulated according to the climate.

However one may vary from the above directions, the following rules should be ironclad: Be sure that the center bearings of each stack are not lower than the end bearings. The line should be straight to avoid sagging and the consequent accumulation of dampness. Be sure that the cross pieces are exactly over each other, else the lumber will become crooked, and be sure that decayed or rotten lumber is not used for cross pieces or foundations, as it will contaminate the good lumber.

THE MAKING OF GOOD CAR INSPECTORS

It Is Evident that More Attention Must Be Given to the Selection and Training of These Men

Among the many papers submitted in the competition on the training and developing of car inspectors, that by A. M. Orr, Bessemer & Lake Erie, Greenville, Pa., was awarded the first place. Several others, however, were in the same class as Mr. Orr's although differing greatly in the method of treatment and the facts which are developed. These will be published in future issues. Mr. Orr's article and one other follow:

FIRST PRIZE ARTICLE

BY A. M. ORR
Bessemer & Lake Erie, Greenville, Pa.

First, what are the qualifications of a good car inspector? They would seem to be good health, good eyesight, experience in repairing cars, sufficient knowledge of English to make out reports, and knowledge of the M. C. B. rules.

SELECTION

So far as the railroad is concerned, the most important moment of the life of the car inspector is when he is employed or transferred to a job which puts him in line for promotion to the position of inspector: and a majority of the troubles with car inspection forces could be avoided by an intelligent choosing of the men who are later to be promoted to be inspectors. It requires as good a man for the position of car inspector as is required for the position of foreman, with the exception that the inspector does not need as much ability to handle men. Yet the inspector is ordinarily advanced as a matter of regular routine, without any choice whatever being exercised in his selection.

There should be some definite point in repair yard work, where the line of promotion to car inspector separates from the ordinary line of repair work; and at that point a selection should be made from among the men who desire to qualify as inspectors. This selection should be made by means of physical and mental examinations, the mental examination being confined to an investigation to determine whether the man has a competent control of English for practical purposes and a working knowledge of the M. C. B. rules. No attention should be paid to errors of spelling or grammar unless they are of such a nature as to indicate that the man cannot understand clearly or make himself understood in English. This may appear to work a hardship where foreigners are used for repairmen, but if we expect harmonious action between the units of the transportation, the maintenance of way and the mechanical departments in a terminal yard, it will be necessary for all the responsible men to understand each other clearly, and that means of necessity a common language.

The physical examination should be intended to disclose organic defects rather than temporary ailments. It should include also a complete optical examination, especially for color blindness. It is not as necessary for inspectors to be correct in their optical judgment of colors as it is for a man in the transportation service, but in such a preliminary examination, where no hardship will be done by turning the man down, it is best to take the safe side. The results of the physical examination, as well as of the mental examination, should be retained for future comparisons.

Objection may be made that mental examinations at this time are useless, and that it is not of value to examine a man physically when he is not to be an inspector for years, if ever. There is a certain amount of truth in this, but if the men with organic troubles or with chronic disease, and the men whose knowledge

of English is so slight that they cannot express themselves are eliminated in the beginning, then it will not be necessary to spend several years giving them special training.

TRAINING AND DEVELOPMENT

After having passed such an examination, the man should be given a training somewhat along the following lines:

- 4 months at truck work.
- 4 months at heavy steel car work.
- 4 months at heavy wood car work.
- 1 year in a light repair yard where foreign cars are repaired.
- 1 year oiling.

Following this, he should either be retained as an oiler or be used as a light repairman in the yard where he will most likely be an inspector when the time comes for promotion. It hardly seems necessary to attempt to go into detail as to the exact things the man should learn in each position. These will come to him step by step, with the aid of his associates and of his different foremen.

A more complete examination in English and on the M. C. B. rules should be given when the man is ready for promotion. There should be an improvement in the use of English in the years which have elapsed since the first examination. It will be noted that the phrase used is "the use of English"; it is essential to remember that a man may be able to convey his thoughts clearly, even though his language is not grammatically correct. He should have a fairly complete knowledge of the M. C. B. rules at this stage, particularly for inspectors who are likely to be assigned to interchange work.

Last comes the question of the development of the inspector after he is in service as a full-fledged inspector. It is probable that the average car inspector could be made at least 50 per cent more effective on interchange work by consistent instruction, either by the correspondence school methods or by personal instruction from a man sent from headquarters who is fully posted on the application of the M. C. B. rules, as modified by the arbitration committee decisions. Whether the gain is worth while or not is a question. It is possible that the added efficiency will not be sufficient to justify the additional cost and trouble.

On the subject of safety inspection, however, there can be no question, and the highest possible efficiency must be obtained, whether in interchange or in terminal inspection. An effective method for developing the inspectors is simply to assume that their education was complete when they were placed under the inspector rating, and to make no definite attempt to give instruction after that time. This naturally involves a study of the record of the results obtained by each inspector, which tends in itself to develop the inspectors, as a knowledge that a superior has a permanent record of one's failures tends to sober down even the most reckless.

INDIVIDUAL EFFICIENCY

To establish this record defects should be divided into two classes, one to include cars which had defects that caused wrecks, or which made it necessary for cars to be set out en route. This is an arbitrary division; it may be modified in any way, but the principle involved is that there is no real difference between missing a defect which causes a wreck and missing the same defect when "luck" lets the car run safely to the next terminal, to be caught by an inspector there. As the division must be arbitrary, any division of very serious cases from ordinary cases may be made. As suggested above, let one class include perhaps all defects which have caused wrecks or derailments. Let the second class include all other cases where defects involving safety are

discovered and where the conditions seem to prove clearly that the defect was missed by an inspector.

Make it established practice to investigate officially every case of the first class and inflict discipline where it is found that an inspector is responsible, even if it be only a letter which is unknown except to the inspector and his foreman.

Pay no attention to the errors of the second class beyond ascertaining the name of the inspector who last passed the car and calling his attention to the defect in a routine way through his foreman. Use the record only when discussing discipline or promotion, with the exception that at intervals of a year or more an abstract should be made of all errors reported during the year. The record of any single error is as near being absolutely valueless as can be, but a general abstract will call attention at once to the man who has to inspect cars too close to a wall which shuts off the light from the under part of the cars, the man who is suffering from illness to an extent which makes him careless, the man whose eyes are going wrong, the man who is dissipating or who has family troubles which have "got on his nerves"; in general, every man who is not doing his best. Knowing which men are not doing their best, it is a simple matter to pay special attention to them and find whether the causes of their troubles can be removed or whether they need to be shifted to some other line of work. All this information will come automatically from the continual investigations and the records of the investigations.

If, at the end of the year or other period of time, we find that the average inspector has three errors charged to him, and some one inspector has 30 errors in the same time, we have an automatic warning that the work of that inspector needs attention. The trouble may be due to conditions beyond the control of the inspector, and even if under his control, there may be a reasonable excuse, but the fact that such cases come up and are investigated and that a useful record is made of them is probably the greatest thing which can be done toward developing the inspector into a conscientious workman.

PERIODICAL EXAMINATIONS

At intervals of perhaps three or five years examination sheets should be made up covering the M. C. B. rules as they apply to foreign cars, and also covering any special local regulations desired. This should be handled from the standpoint of the correspondence schools, whose motto is that a man learns a thing thoroughly when he lays it out in his mind and puts it down on paper. The examiner should pay no attention to the form of the English; anything should go which shows clearly that the man could handle the situation on interchange, and no restrictions should be put upon reference to the M. C. B. rules, the M. C. B. arbitration decisions, or other sources of information.

The following is a sample of an examination sheet for car inspectors:

EXAMINATION SHEET FOR CAR INSPECTORS

- What is the object of the M. C. B. rules?
- When is a company, operating the cars of another company, responsible for the defects on such cars?
- Who is the judge as to whether a car offered in interchange is "safe and serviceable"?
- What is done with a defect card and its stubs after the card is made out?
- What should be done if an inspector of a connecting road asks for a copy of a defect card?
- When would you refuse to give a defect card for defects on a car?
- Under what conditions would you receive a car having defects for which the owner was not responsible?
- What are the defects of wheels for which an owner is responsible?
- What is the defect of wheels for which they should be most closely inspected?
- For what defects of the axles are the owners responsible?
- How can you tell if a car is loaded too heavy for its axle capacity?
- For what defects of the trucks are the owners responsible?
- For what defects of the brakes are the owners responsible?
- Why are the interior parts of the cylinder and triple exempted from the general rule that the delivering company is responsible for missing air brake material?

If a car is equipped with air-signal pipes, who would be responsible if the signal hose and angle cocks should be missing when the car was offered in interchange?

- For what defects of the body are the owners responsible?
- What does the rule regarding the standard height of couplers mean?
- What are the requirements for grab irons and handholds?
- If a company makes wrong repairs to a foreign car, to whom is it responsible?
- What is the meaning of the phrase "unfair usage"?
- What defects of a car should be repaired?
- What do you consider the most important principles covered by the M. C. B. rules, so far as the repairing of foreign cars is concerned?
- If you could not obtain the proper material for making repairs to a foreign car promptly, what would you do?
- Are you allowed to use second-hand material in repairing foreign cars?
- When must you show on your stub that material applied was second-hand?
- When a foreign car is found with the coupler above or below the limits of standard height, what should be done?
- May draft timbers be spliced?
- Give a rough sketch of the proper method of splicing sills, and give your idea of the rules governing the splicing of sills.
- What do the M. C. B. rules say as to the application of air hose?
- What are the rules regarding the giving of joint evidence cards?
- What special information must be shown on repair cards, as, for example, in the case of brasses and similar material?
- If you make only a part of the repairs on a car which are covered by a foreign defect card, what should you do with the card?
- In what case is it necessary to show on your repair card whether the car had a stem or pocket coupler?
- How do you check your car numbers and initials so as to avoid as much correspondence as possible over correction of stubs?
- If a car was offered to you in interchange with a part missing from its place, and a defect card on the car for the part "loaded in the car," what would you do?
- How could you tell if a carload of long material was not too large to pass through to its destination without being transferred on account of being too large to go through a tunnel?
- If you were sent out to inspect a load of telegraph poles, loaded on two cars, what things do you consider it necessary for you to specially inspect about the cars and their lading?
- What are the requirements for blocking, etc., on a flat car loaded with large stone?
- How many brakes must be effective on three cars chained together and loaded with long steel?
- What are the requirements for side stakes on loads of telegraph poles?
- Describe the testing of the air brakes on a train.
- What are the general duties of an inspector as regards the air brake apparatus?
- What are the air brake defects for which you should be most particular to inspect?
- What is the requirement as to piston travel?
- If you found an air brake defect which could not be repaired at your station; or if for any other reason it was desired to "cut out" the brake, describe fully what you would do.
- Why is it necessary to test the air on a train when it is first made up, and thereafter whenever it has had its cars changed around?

Beyond this, it does not seem necessary or profitable to go. It would be much nicer to have a nice lot of inspectors, all intelligent users of English, all in perfect health and with good judgment, but heaven has not yet come to the railroads, despite the earnest endeavors of the interstate and the various state commissions, and it is necessary that we be satisfied with a good average.

MAKING A CAR INSPECTOR

BY E. C.

In order intelligently to discuss how car inspectors should be trained and developed and what are their qualifications, it would be well to consider their duties and the conditions under which they work.

The object to be attained in the inspection of cars is primarily the discovering of defects that are liable to cause disablement of the cars during transit, with resultant delay to traffic, wrecks and possible loss of life; the same applies to the lading in the cars, particularly in open cars.

In making his inspection of a car, the car inspector must be alert to discover, first, the parts that have actually broken down; second, the defects which may develop into subsequent failures, and third, those defects which, while of a minor nature, must be considered and judgment exercised in deciding whether they

should be remedied at the time or the car be permitted to proceed.

THREE CLASSES OF INSPECTORS

There are three phases of inspecting: initial, interchange and intermediate. The initial inspector, who inspects cars before and after loading, has probably the most varied duties of any; he bears the responsibility of deciding whether or not cars are in fit condition for carrying a variety of commodities; he must inspect box cars inside as well as outside.

Some cars are fit for certain shipments and unfit for others; some he may take a chance on if the weather appears to be settled, but not otherwise. Some cars he does take long chances on and is commended as being a "good" inspector by the agent or yard master, who at the time are hard pressed to supply the shippers with cars. The initial car inspector must know that the loading is done in conformance with the rules; he must also know that the dimensions of cars and lading are within the clearance limits for the routes over which they are to travel, and must never forget the safety appliance law. In short, this man bears the responsibility of seeing that cars and lading are both in the proper condition to reach their destination in safety. Should he fail in the discharge of his duties he may cause his employer unlimited expense by reason of transfer, delays in transit, claims for damaged lading, additional cost for repairs and possibly thousands of dollars on account of a single wreck.

After the initial car inspector comes the inspector at points of interchange. His duties are similar as to hunting for defects in running gear, sub- and superstructure, testing of handholds, steps and ladders; examining running boards, box car doors and the seals, and also the loads to see that they have not shifted. He must also think about dimensions of cars and lading and not let any slip by that exceed the limit of routing. While all car inspectors must be familiar with the M. C. B. Rules, the interchange man has to apply them more frequently than the others. The intermediate man or the inspector who is stationed between the point of loading or interchange and destination has all the duties of the latter, with the exception of applying the rules of interchange, but he must be familiar with the M. C. B. Rules that apply to any repairs that he may make.

GENERAL REQUIREMENTS

In addition to the inspection mentioned, all inspectors are required to keep accurate record of defects found, repairs made, and cars marked for the repair tracks. Some of these records must be so-called "original" records, *i.e.*, the first record made, which must be filed for future reference. M. C. B. billing repair cards have to be made out by the car inspectors for repairs made by them.

So much in a very general way for the duties of the car inspector, now let us consider the conditions under which he must perform those duties. No matter what the weather—rain, blizzard, bitter cold or sunshine—he must be on the job, over the tops of cars, along by the sides and frequently underneath, intently looking for the least as well as major defects. In yards and at transfer and freight stations the tracks and platforms are usually so close to one another and the cars that the light during daytime, particularly on cloudy days, is not sufficient to reveal such defects as seams in throats of flanges, cracked arch bars and similar defects. A lantern, unless it is very dark, is of little assistance; rain also hides some defects, and it need hardly be said that snow and ice cover up many others. Nevertheless, the car inspector must not be guilty of failing to detect any defects that reveal themselves by some disaster later on.

RELATION TO OPERATING DEPARTMENT

Then, in classification yards in particular, there is the yard force, headed by the yard master, who never by any chance makes the car inspectors' work easier, but rather the reverse! The time allowed in which to inspect a train, whether the latter consists of 20 or 100 cars, is usually 30 minutes, which by cajolery

or otherwise, depending upon the man, the yard master, or one of his numerous assistants, frequently tries to have shortened to enable the quicker movement of the train through the yard.

The car inspector is at the "beck and call" of everyone and is the most cursed man on a railroad. Should a trainman discover some little defect when making up a train he wants to know where "that ——— car inspector is," or if the latter puts the former to the trouble of cutting out a car from a train that is made up, the same gentleman invites the poor car inspector to go to a very warm place.

It probably is a fact that our friends, the yard people, would rejoice if every car inspector were discharged offhand, for their immediate troubles, for which they hold the car inspectors responsible, so overpower their reason that they fail to appreciate the immeasurably greater trouble that is saved them every day by the work done by these much-abused men.

TRAINING AND DEVELOPING INSPECTORS

I think it is not exaggeration to say that car inspectors as a class and by their unassisted actions prevent more accidents on the railroads of the country to-day than any other single class of railroad employees.

What manner of man, then, must the car inspector be, and how should he be trained and developed? As it is not ordinarily practicable to select the future car inspector from applicants for "jobs," no more than the usual care can be exercised when employing men. Depending on circumstances, car inspectors are usually developed from car repairmen. Without question, they should always be car repairmen on regular repair tracks before promotion to inspectors. By working on repairs the men become familiar with the various parts of cars, how to make repairs, the character of defects found by the inspectors, and this is done directly under the eye of the foreman, who thus has opportunity to become thoroughly familiar with the varied characteristics of his men.

At this stage in the development of a man a great deal depends on the foreman. If he is not what he should be, good car inspectors will not be developed under his tutelage, but as this article is not on the qualification of the foreman, that phase of the subject will not be discussed, and we will assume that the foreman is the right kind of man. After a few months on the repair track—in speaking of the repair track I do not mean at the main shop, but the tracks set apart for heavy running repairs, light running repairs being made in the receiving or classification yards—during which time our man should be given every kind of repairs to make, he may then be sent out into the yard to oil and sponge journal boxes or make the minor repairs which will prevent cars from being cut out for the repair track.

Only those who have exhibited an interest in the work of the repair track, and on whom dependence can be placed, should be selected for this work. The man who has been lazy, unobservant and indifferent should never be sent out, for he will now be away from under the eye of the foreman and will be placed more or less on his honor for the faithful and diligent performance of his duties.

After filling the places of oilers or repairmen, who are off sick or otherwise absent, the prospective inspector will be given a regular place, probably at night; first, as oiler, if possible, or as repairman, from which he will work in his turn to a similar day position. In possibly two, three or four years the opportunity comes for his advancement to the position of inspector. Prior to that time, however, he will have filled temporary vacancies as inspector, and in this way have obtained actual experience, although his opportunities while repairman in the yard were ample to develop his faculties of observation.

As inspector, his first duties should be overhead inspection, since the more important end is that of running gear, couplers and parts near the ground; in course of time, and as opportunity affords, he should be promoted to the ground. I use the word promoted advisedly, as I believe that the ground man should

receive a higher rate of pay than the roof, or overhead, man, since the former position requires more concentration of thought, a keener eye, more frequent exercise of judgment and a greater variety of parts to be inspected, and in every way demands higher qualifications on the part of the inspector.

For inspectors who are required to supervise loading of cars, in particular of explosives, structural iron and other long material, only those who exhibit good judgment, coupled with a fair knowledge of the various rules and regulations, or are known to be capable of acquiring and applying that knowledge readily, should be selected. Likewise only the best-equipped men should be used where interchange work is involved.

The training of men does not cease when they become inspectors, as the least of them will slack off more or less unless the foreman follows them up in their work, not in a nagging, but rather in an educational way, encouraging them to overcome the difficulties that beset their path and perfect themselves in their duties, imparting all the knowledge of which he himself is possessed and guiding their judgment in the right direction.

It would seem that the prevailing idea in circles other than that of the car department is that a car inspector can be made overnight out of any old kind of material; such is far from being the case. Very few of the men offering themselves for this work or remaining in the occupation are naturally good inspectors; such men do not find the rate of wages sufficiently attractive. It takes years of persistent, concentrated effort to make a proficient car inspector and continued years of similar effort to keep him up to the mark.

The opportunities for advancement open to a car inspector may truly be said to be unlimited, for they depend upon the man himself, as in all other occupations. Of course, within the immediate horizon of the somewhat better than average man it must be regretfully admitted that the opportunities are not numerous. First there is gang leadership at a small advance in wages, and then the position of foreman, at which he is apt to stop unless possessed of qualifications not ordinarily found among car inspectors.

CONCLUSION

In conclusion, a car inspector should be:

- (1) Faithful in his duties, even under the most adverse circumstances, loyal to his employer.
- (2) He should be alert, keen of eye and observant, possessed of good judgment and a desire to improve.
- (3) He should have a thorough knowledge of the various rules pertaining to his work and be capable of applying them intelligently.
- (4) Last and not least, he should be possessed of an equitable temperament.

The question of development and training of the car inspector may be summed up in a very few words. Given the right kind of man, the rest depends almost entirely on the foreman and the way in which he handles the man.

The average man in all walks of life requires a lot of encouragement to keep him up to his best efforts, and the car inspector perhaps requires a lot more than the average and needs more judicious sympathy than usually comes his way.

CHEMICALLY REMOVING RUST.—The chemical removal of rust from iron was treated in a paper recently presented to the Iron and Steel Institute in London. Dilute solutions of sodium citrate have been usually recommended as suitable media for loosening rust without dissolving any iron, but the authors of this paper point out that these solutions are unsuitable for investigations involving the quantitative removal of rust and that they are also extremely slow in their action. Various other chemical reagents were tried, none of which proved as useful as boric acid. It did not appear possible to find a reagent which would remove rust quantitatively without also dissolving some of the iron.

CHILLED IRON WHEELS

The Association of Manufacturers of Chilled Iron Wheels met in New York on October 12. All of the officers were re-elected. They are as follows: President and treasurer, George W. Lyndon; vice-presidents, E. F. Carry and J. A. Kilpatrick; secretary, George F. Griffin; consulting engineer, F. K. Vial. The board of directors consists of E. F. Carry, J. A. Kilpatrick, W. S. Atwood, Charles A. Lindstrom, F. K. Vial, A. G. Wellington, W. C. Arthurs, J. D. Rhodes, F. B. Cooley, A. J. Miller and William F. Cutler. In addressing the meeting President George W. Lyndon said, in part:

It is gratifying to know that the chilled iron wheel has not only been able to maintain itself as the wheel standard of the United States and Canada, but it is beginning to supplant the European standards, as evidenced by the fact that several manufacturers of this association are supplying chilled iron wheels in large quantities to the French and Russian governments.

That our flange recommendations are in the line of improvement is fully demonstrated by the fact that we have at the present time over one-half million wheels running that are finding their way through the present track construction without any complaints. The flange used on special wheels is 3/32 in. thicker than the M. C. B. flange, and the flange as shown in our final argument is 3/16 in. thicker at the gaging point than the M. C. B. flange.

It is our purpose to have a sufficient amount of metal in reserve in order to enable us to design a chilled iron wheel of 950 lb., or heavier; in other words, we are building for the future. We do not want the limits of the possibilities of the chilled iron wheel confined by the limitations of flange design. We want no unreasonable restrictions in the use of the chilled iron wheel.

In March of this year we submitted to the chairman of the wheel committee of the M. C. B. Association a new set of standard specifications, recommending the following:

650 lb. wheel—brake pressure.....	19,000 lb.
750 lb. wheel—brake pressure.....	32,200 lb.
850 lb. wheel—brake pressure.....	40,000 lb.

and detailed drawings of M. C. B. types of wheels and arch plate type of wheels.

There is absolutely no limit of weight in the case of steel wheels, but when it comes to a design of chilled iron wheels, all sorts of restrictions follow. We all know what an additional 25 lb. of iron will do to any of the standard M. C. B. wheels in the matter of drop and thermal test, and the proof of this is manifest in our 625-lb. M. C. B. pattern, which we were enabled to redesign in the year of 1909 by the additional allowance of only 10 lb. of metal.

There are some tests which would establish the chilled iron wheel on a much firmer basis, and I believe would be advantageous to all manufacturers. The tests that I refer to are comparative tests of the chilled iron wheel and the steel wheel.

1—Relative wearing values when rotating on a steel rail under various loads, the tread wear and flange wear to be observed separately.

2—Abrasion of rail under various conditions of loading.

3—Determination of the intensity of heating stresses in all parts of the chilled iron wheel, namely, single plate, intersection of plates, front plate, back plate, brackets, etc.

4—Analysis of the thermal test. Intensity of stresses in various parts of the wheel, and effect of thickening the thermal ring, increasing and decreasing the temperature of the iron, etc. The thermal test should be made an intelligent one instead of the present crude affair that is supposedly alike for all weights of wheels.

5—Determination of stresses in the hub and plates of the chilled iron wheel due to pressing on axles. Variation in stresses due to various classes of machining.

SHOP PRACTICE

DRILL MOTOR EXTENSIONS

BY V. T. KROPIDLOWSKI

A convenient set of telescoping extensions is shown herewith, which has been developed for use with air motors in all drilling operations about a locomotive. These tools are in constant demand by the floor hands, and are rapidly replacing the "old man."

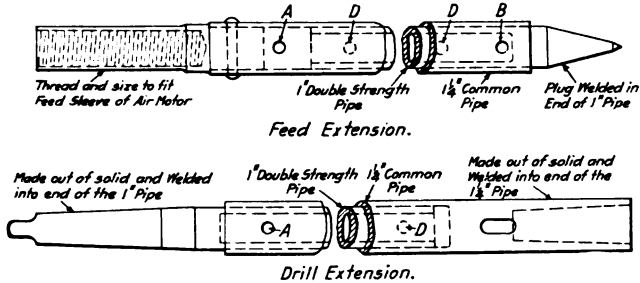

Fig. 1—Construction of the Motor Feed and Drill Extensions

the reason for their preference being their lightness and ease of application and adjustment.

Fig. 1 shows the construction of the extensions for both the feed end and the drill end of the motor. As is seen, the tools are made out of 1/4-in. single-strength pipe and 1-in. double-strength pipe. The feed extension has a plug welded into the

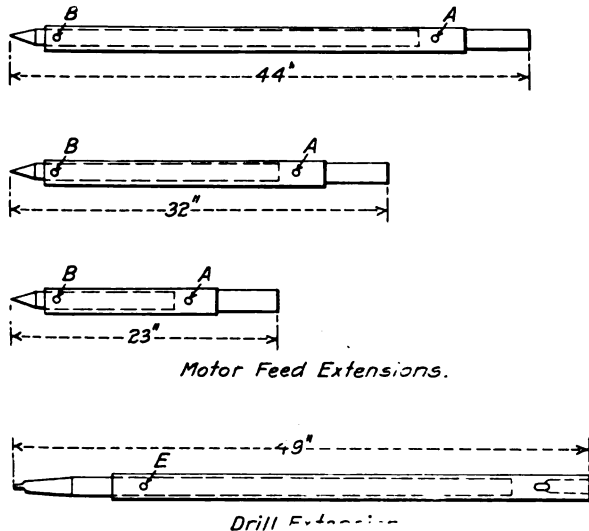

Fig. 2—Sizes Used for a Set of Drill Motor Extensions

end of the 1-in. pipe, which is pointed and serves as a center. In one end of the 1/4-in. pipe is riveted a machined piece which is bored out and threaded on the inside and turned on the outside to fit the feed sleeve of the air motor. The drill extension has a Morse taper shank welded into the end of the 10-in. pipe, and Morse taper socket in one end of the 1/4 in. pipe. Through the inner, or 1-in. pipes of both extensions are drilled holes *D*. These are spaced 2 in. apart and are 7/16 in. in diameter. By means of them the tool can be extended or shortened, being held in the desired position by the insertion of a 3/8-in. pin through a hole in the outside pipe and one of the holes in the inside pipe. The holes in the outside pipes of the feed and drill extensions are shown at *A* and *B* respectively.

A set of three of each of these tools, or six in all, fills all the requirements of drilling operations about a locomotive. The lengths to be used are shown in Fig. 2, but one length being

shown for the drill end. The other two should be made of such lengths that they will have the same ratio to the full-length extension shown as the shorter motor feed extensions have to their full length tool.

Fig. 3 shows the method of using the extension tool for the feed end of the motor in drilling a running-board bracket. All

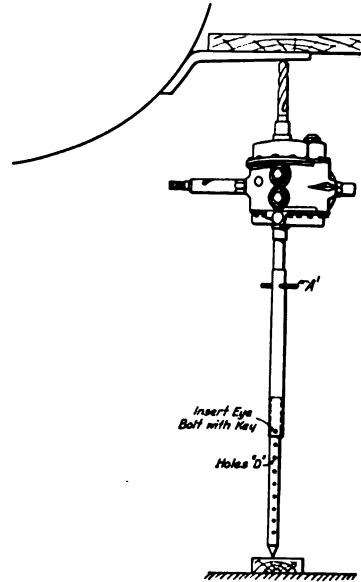

Fig. 3—Method of Using the Feed Extension

that is necessary is to remove the star feed from the motor and screw on the extension, pull out the inner pipe until it has the required length to suit the distance from floor to running-board, then insert the pin or eye bolt to keep the tool in the extended

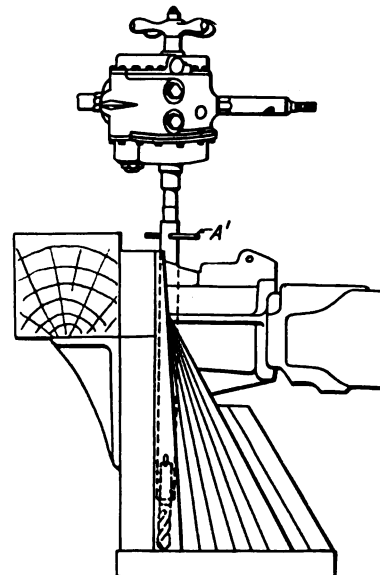

Fig. 4—Using the Drill Extension in Drilling a Pilot Heel Plate position. The motor is then set up and final adjustment made with the feed by turning on the pin *A'*.

Fig. 4 shows one example of the use of the drill extension in the operation of drilling the heel of a pilot, which is self explanatory.

This set of tools greatly facilitates the work of many drilling

operations. Among these may be mentioned: Drilling across the frames; all inside fire box drilling; lumper beam plates; drilling running boards in place; stay bolts in throat sheets and holes in heels of pilots for pilot braces.

PROTECTION OF IRON AND STEEL

BY J. W. GIBBONS

General Foreman Locomotive Painters, Atchison, Topeka & Santa Fe, Topeka, Kan.

We must have some knowledge of the composition of a material and of the agencies that commonly enter into its destruction in order properly to protect it. Thorpe, in his Dictionary of Applied Chemistry, quotes a number of authorities to prove that the corrosion of iron and steel is caused by an electrolytic action which takes place between the metal and its impurities when moisture is present. The impurities are carbon, manganese, etc. These constitute an electro negative, the metal an

mixed with the pigments will be the most impervious to water.

When we consider that uric acid and ammonia are deposited on stock carrying equipment, and sulphuric acids on coal carrying vehicles, and that sulphur fumes from coal-burning locomotives are present on all railway equipment, it is apparent that an oil which will absorb a high percentage of moisture will carry these destructive acids into the paint next to the metal and accelerate its destruction.

To determine what would make the most impermeable vehicle,* I made the following tests:

Exhibit A was composed of films of treated and non-treated linseed and other oils. Each film was submerged in water for 72 hours and the films have been marked, showing the percentage of increase in weight, or in other words the amount of water absorbed. This test also brings out the fact that the accelerated method of testing the elasticity of paint films employed by paint chemists is of no value unless a test of contraction is also made. To illustrate this films 7, 13 and 14, which



Exhibit A—Exposure Test of Films of Treated and Non-Treated Linseed and Other Oils

electro positive and the moisture the electrolyte which starts the electrolytical action, precipitating the metal into a solution. Air entering through the water causes a reaction which returns the metal to its original state, oxide of iron, commonly called rust. Acids augment and aid this electrolytical action and when they are present in the water accelerate the destruction of the metal.

Thorpe also states that some acids will neutralize the effect of others and that a combination of certain acids will stop all corrosion. It is also proved that in the absence of moisture, or in other words, the electrolyte, there can be no electrolytical action, hence no corrosion. Therefore in selecting pigments to make a paint, we should select "inhibitive" pigments which neutralize the acids. Carbon, being a stimulative pigment (electro negative), should never be applied next to metal.

It is generally accepted as a fact that a paint composed of

will stretch more than their own length without breaking, are as brittle as glass at 8 deg. F., and have no value as a paint vehicle when exposed to a low temperature.

Those films marked with the letter "B" were baked at 135 deg. F., which, of course, properly speaking, is not baking, but accelerated drying.

The films numbered from 0 to 3 were made from the same grade of red lead, ground in the same mill and baked at 250 deg. F. The one marked 0 was mixed with raw linseed oil and increased four per cent in weight. Nos. 1, 2 and 3 were all heat treated oils, heated to different degrees of temperature. No. 3 was the only one held at a high degree of heat long enough to make a heavy viscous oil; it required a small percentage of volatile oil to thin it to a working consistency, but the film is as thick as any of the others made from the same number of coats,

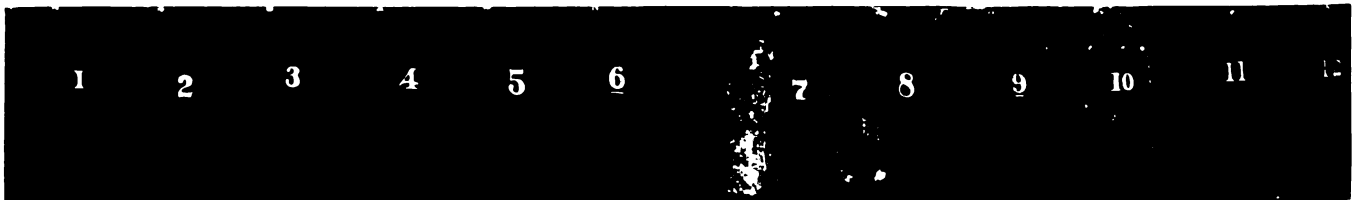

Exhibit B—Exposure Test of Sandblasted Steel Plates Which Were Given Two Coats of Paint and Bolted to Underframe of Locomotive Tender. Nos. 7 to 12 Inclusive Were so Placed that Water from the Tank Dripped on Them

a combination of several pigments gives better protection than a single pigment paint, providing, of course, that the pigments so combined are of different degree of fineness, thus complying with what Perry calls the "law of minimum voids." I believe that the several pigments also have the same tendency that a mixture of certain acids has, as explained by Thorpe, namely, to neutralize the electrolytical action.

As all authorities agree that in the absence of moisture there can be no electrolytic action, or corrosion, in selecting a vehicle for the pigments it is essential that an oil be used which when

in fact, the raw linseed oil film is thinner and more fragile than any other in the same group. This demonstrates that in addition to giving protection against the absorption of water, the heat treated oils, if not thinned out excessively, will also give more protection against attrition than the raw or "bung"† boiled linseed oil paints. As the air dried films absorbed more moisture

* See test committee's report, Master Car and Locomotive Painters' Association, 1915. This report was abstracted in *The Railway Age Gazette, Mechanical Edition*, October, 1915, page 538.

† By "bung" boiled linseed oil we mean oil to which driers have been added; it is then sold as boiled linseed oil, although as a matter of fact the oil was never boiled.

than the baked films and the films baked at 250 deg. less than those dried at 135 deg., it is evident that the accelerated drying of paints by artificial heat is desirable. Practical tests exposed at five different points on the Santa Fe Lines in 1913 and 1914 substantiate this conclusion.

Exhibit B was composed of steel plates which were sand-blasted and given two coats of paint, a different mixture being applied on each plate. The plates were bolted on the interior of a steel underframe of a coal-carrying locomotive tender. Nos. 1 to 6 were in a position where comparatively little moisture

As carbons are inert and not subject to change by the action of acids or alkali, a combination paint with a carbon base, ground in heat-treated linseed oil, will make a good over or finishing coat. Where three coats are necessary or desired, the primer and finishing coats should be mixed together in equal parts and used as a second coat. These paints can be purchased for less than the single pigment red lead paints can be made by hand.

As the value of a protective paint may be destroyed by excessive use of thinners or by improper application, and as the average journeyman painter knows or cares but little about the

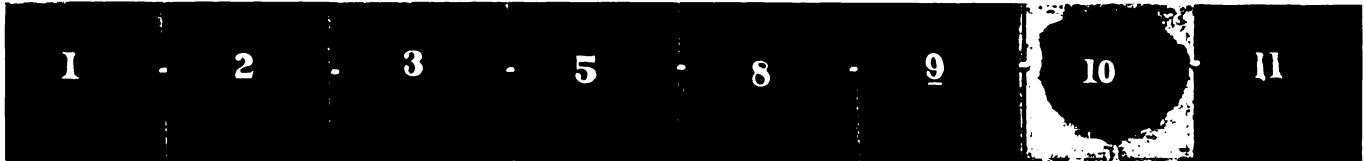

Exhibit C—Plates Which Were Treated the Same as Those in Exhibit B, and Were then Fastened to Roof of Passenger Coach

came in contact with them. Nos. 7 to 12 were under a cistern which leaked; they became thoroughly saturated with water and deposits washed from the coal.

Exhibit C has the same paints as Exhibit B, but the plates were fastened on the roof of a passenger car, which was used every day for 10 months behind a coal-burning locomotive. The effects of the cinders, snow, rain, ice, etc., are apparent as the results of the test of Exhibit B and Exhibit C are comparatively the same; the only paints which have protected the steel to any considerable extent are those mixed with a heat-treated oil.

The service tests confirm the conclusions drawn from the film tests and prove the value of the film method of testing paints. Note the conditions of plate 7, which is recorded as a total failure. This is a single pigment paint (red lead) mixed by hand with raw linseed oil. The film made with the same grade of red lead and mixed by hand with "bung" boiled linseed oil absorbed 1/5 per cent more moisture than the same material ground in a modern paint mill. It proves the theory that a paint properly ground will give better service and will be more impervious to water than the hand mixed paints.

As red lead is worth at present 6 1/2 cents per pound, and raw linseed oil 48 cents per gallon, and as 25 pounds of red lead mixed with one gallon linseed oil will make approximately 1 1/3 gallons of paint, this mixture will cost \$1.57 1/2 per gallon, not counting the labor necessary to mix it. As the particles of pigment are comparatively large and coarse when mixed by hand, they contain a number of "voids" which increase the porosity of the paint film and expose it to the action of the destructive acids which may be present in the water.

Steel plate 11 primed with a combination of red lead silica silicates (Asbestine) and calcium carbonate ground in heat-treated oil, and second coated with a combination of carbon and basic carbonate of lead, ground in heat-treated oil, has given remarkable service under very severe conditions in three different tests, thus proving that it has elements of great value as a paint. I attribute its preservative qualities to two things, the impermeability of the oil obtained by the heat treatment, and the "minimum voids" in the mixture obtained by the different degrees of fineness of the pigments used.

In connection with this it is not out of place to mention that the Atlantic City fence test, conducted by the American Society for Testing Materials, proved to its satisfaction that sublimed blue lead was the best practical paint pigment for the protection of steel and as this pigment is exceedingly fine and will enter into the pores of the oil, I have no hesitancy in recommending as a primer for iron and steel a combination paint with a red lead or sublimed blue lead base ground in an oil which has been heat-treated.

composition of the material he is employed to apply, it becomes absolutely necessary, in order to secure good results, to have intelligent and efficient supervision.

DEVICE FOR PLACING AIR PUMPS

BY W. S. WHITFORD

General Foreman, Chicago & North Western, Milwaukee, Wisc.

The device shown in the accompany illustrations is in use at the Chicago & North Western shops at Milwaukee for hoisting air pumps into place on the locomotives. The device consists of a pole to which are attached two long chains, and a special

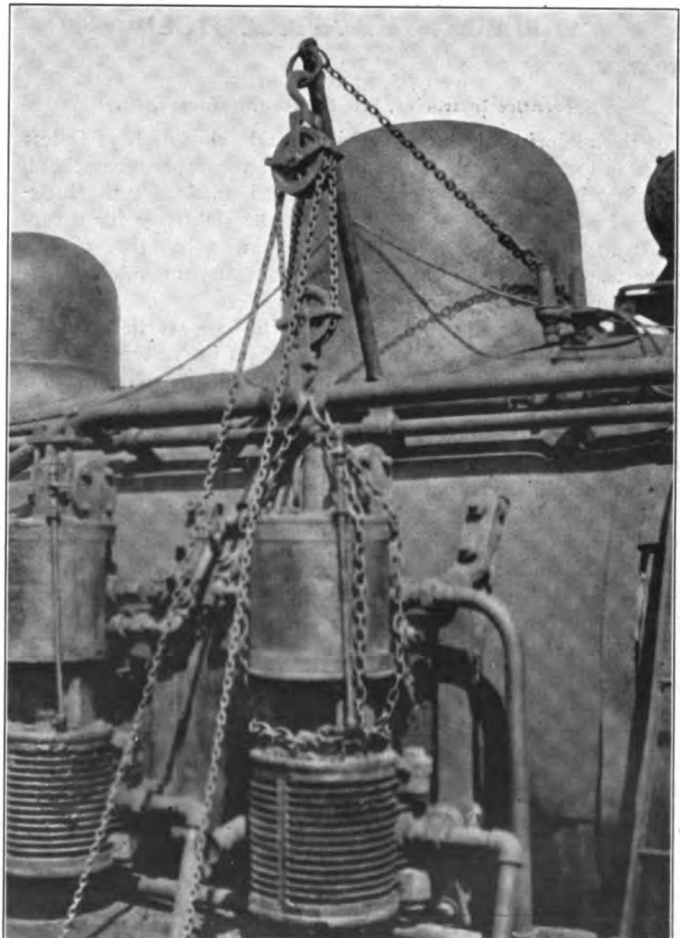

Air Pump Being Placed in Position on the Locomotive

chain sling which is attached to the air pump. The pole is made of 2-in. pipe, the lower end being forged and welded to fit over the hand-rail and the upper end provided with a means for attaching the chains and a link to receive the hook of the upper chain block. The chains are long enough to be extended over the boiler and are attached to the hand rail on the other

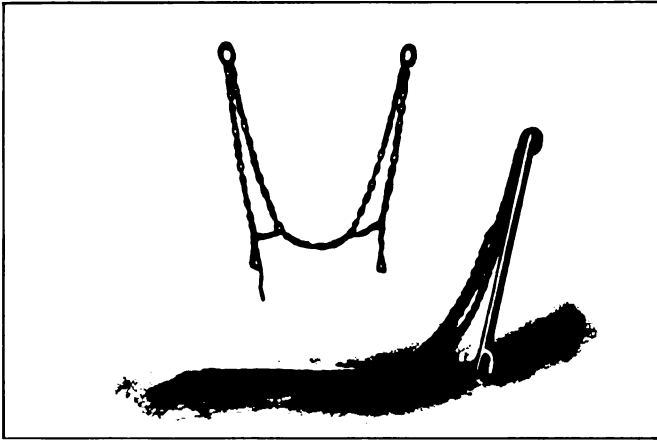

Details of Chain Sling and Pole with Supporting Chains

side of the engine thus securing the pole in the desired position over the air pump bracket. The air pump sling is shown in one of the illustrations and consists of a belt which is fastened around the central part of the pump and to which are secured the lower ends of two double lifting chains. The upper ends of these chains terminate in links which hook into the lower chain block.

HELPING THE APPRENTICE*

BY H. E. BLACKBURN

Apprentice Instructor, Erie Railroad, Dunmore, Pa.

In the majority of shops the hiring and firing of boys is left to some foreman who has no interest in the apprentice school, and right here is where the first mistake is made, for the judgment of a Solomon is needed to select the right boy for a certain trade and unless some one person who has the school's interest at heart is held accountable for results the value of the instructor is lost.

If the instructor wishes to win out with boys worth while, he will have to find some way of keeping them interested in a line of practical work in connection with the shop problem work. To do this he will have to have a strong personality so as to resort to tact, for mother wit and common sense is the only "dad" to whip boys into line for mechanics.

A boy may like you personally, but he may hate your methods of discipline—it is fatal to force a boy to do a thing against his own limitations. It is far better to try him out on something more to his liking until you can get him to see things in the proper light. To do this you will have to overlook his many shortcomings and become his only aid when he is up against a hard proposition. The primary aim of the instructor should be to teach the boy by actual example because the eye is the greatest educator, and objects and not books are the prime factors for a lasting impression as to how the work should be done. Books and theories have their place, but not with a first year apprentice, for the average boy who "sees" the wheels go around will immediately want to know why they turn, and what makes them go; that is, if he is the right kind of a boy to learn the trade.

Instead of giving all the boys a general lecture, which is liable

*Entered in the prize competition on "How Should Car Inspectors Be Trained and Developed, and What are Their Qualifications?" which closed October 1.

to lead to "heave ho" methods, have a heart to heart talk with each boy relating to the work he is doing in the shop; give him some problems that specially cover his work, but do not tell him all that you know about the subject. It is better to make him work out his own salvation from the study of models and charts.

Another fatal mistake is that the average instructor does not know what is going on in the shop between the foreman, mechanics and the boy, for while the instructor is trying to show the boy some up-to-date method of working, the shop force may be coaching him to do the work twenty years behind the times; this keeps the school and shop efficiency down, simply because the boy does not know where he is at. If the boy is to become proficient he must know why he does the work a certain way, so as to use as few tools and movements as possible.

If the boy spoils a piece of work after you have been careful to show him how it should be done, don't "flare up," but find him more material and keep him at it until he makes good; then compliment him on the results and move him on to some better work. If he continues to improve make him a teacher, to show the next boy in line for the work how it should be done. It will please the boy and help the instructor, to say nothing of making him one of the "props" of the school. He will soon learn to pull for himself and try to pass the boy ahead of him. And if you can teach him that skill is only a matter of intelligent labor, and that higher mathematics are not needed to work out his daily problems, you will soon have a boy for the trade worth while, for first hand knowledge is the lasting knowledge that counts.

Avoid going over the same subject again, but compare any new subject to the past studies, if possible. As every boy has a natural dislike for some part of the trade, it is well to encourage them to become proficient in that part that they like best, so that their ability as mechanics may be recognized long before they are out of their time.

In order to help the apprentice so that he can help himself, build a small shop and equip it with machines, benches and tools (not junk), or set apart some machines and benches for the boy's use in the shop, so that he can work on regular shop output work. Next give him a living wage, so that he can support himself, and you will get more man and less "kid" for the money expended. As soon as he can do a good job on a day work scale, let him have all that he can make at piecework. Don't merely give him a certain per cent of it, if he does the work correctly.

Place the larger boys in the erecting shop, and the smaller boys on machines until they are able to cope with the heavy work. While in the shop, if the boy likes to draw, give him a set of drawing instruments and let him handle the shop drawing. Later on let him try to design some tool to help the shop output along. Advance the boy who does not like to draw as fast as he understands how to clamp and chuck work on the machines. Be sure that he understands how to grind cutting tools and how to use the proper feeds and speeds to get results. Make him watch you file and chip, not some "hunkie" who is "choking the hammer to death."

If you find a boy who thinks he knows it all let him build a model locomotive; it may change his mind. If you have a boy who does not realize his capability draw him out by having him help the boy who knows it all, and then remove the boy who talks and does nothing. It will shame one and encourage the other. It is good practice to let one boy criticize the other boy's work at any time.

While he is in school teach him the names of the various tools and their uses in the shop; in fact keep a model tool room in the school. Next start him out on lettering and straight line drawing. Also explain the three views of an object that are required in a drawing. Then let him make a free hand sketch. If he does not like to draw, do not waste any more time or

paper trying to teach him after he can make and read a fair looking print.

It is good practice to have the boys debate on subjects such as the standard ways of doing work. If the boy is encouraged to read railroad magazines and talk in school he will (if you have the right kind of a boy) see new things in the journals that will start him to figuring. Keep the school open at night. Organize a band or an orchestra. A wireless club will be the means of bringing in boys who like to fool with wire and batteries, and so you may find good material for an electrician; in fact, do anything to keep the boy off the street, for one season on the street has ruined more boys' chances than any other cause. Later on you will have an organization whose team work in baseball and football will give the school a good advertisement wherever they go.

As regards the future, much depends on the railroads and the class of instructors they employ to educate the apprentices. Germany has proved beyond doubt that it pays to educate and develop the mechanical genius that is going to waste in America.

PISTON VALVE PACKING RINGS*

(PRIZE ARTICLE)

BY W. F. LAUER

General Foreman, Illinois Central, Memphis, Tenn.

A successful steam locomotive depends largely on a perfect valve. It matters not how good a locomotive may be otherwise, if an inferior valve is used, or if the valve is not properly taken care of, the locomotive is a poor revenue earner. There are three vital points to be considered, and each is essential to the efficiency of the locomotive; these three points are: Kind of valve; its construction, and its maintenance.

The best valve is the piston valve, as it is the most equally balanced. The best constructed valve, considering the work that is done on it in the shop and the roundhouse as well as its service, is what is known as the "built-up valve." This consists

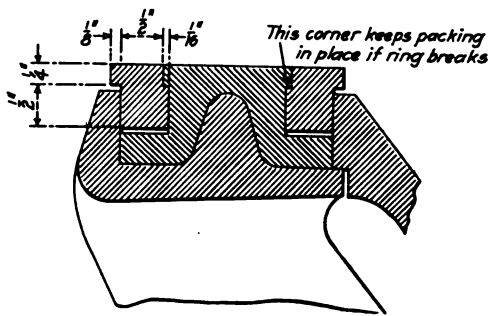

Fig. 1—Application of the Z-Ring Packing to Piston Valves

of two spiders made of cast steel, one spool or body made of grey iron, two bull rings and four packing rings. The bull rings should be of good material, sufficiently hard to avoid excessive wear. The packing rings should be of a high grade cast iron, that will retain its life or spring under the use of superheated steam. (There is an iron on the market today that fulfills this requirement.) The ring should be of the Z-shape type. This type is better than the rectangular, L or T-shaped rings, for the reason that it is so constructed that in case of breakage the parts of the ring will not work out of the groove (see Fig. 1), thus eliminating the possibility of the broken parts of the ring knocking out a cylinder head or breaking the valve bushing and causing an engine failure. When this type of ring breaks, the only result will be a "blow" in the valve, and the engine will be able to take the train to its destination with the broken parts of the ring in place.

The Z-ring should be machined on a boring mill, from tub

castings large enough to produce 10 to 20 rings each. Both heads of the boring mill should be used, one for turning and the other for boring, both operations being done at the same time. The casting should be finished on the inside and on the outside before the forming or cutting-off takes place. Our method of cutting off these rings is shown in Fig. 2. The tool in the right head cuts into the inside of the tub the same as though an L-shaped ring were being made. The tool in the left head cuts off the ring from the outside and is so placed that it runs a trifle off the line of the inside tool, thus separating the ring from the tub and forming the "Z" section at the same time. No broken edges are caused by the tools going through and tearing the iron; all the corners are absolutely square. This operation is continued until all of the rings are cut from the casting. Snap gages are used to gage all of the rings while they are being made on the mill. There is no second machining. The cost of machining, as described, is 6 cents each. Either the Z, L or T-shaped rings may be made with gang tools cheaper than by the method described, but by so doing, the rings cannot be as

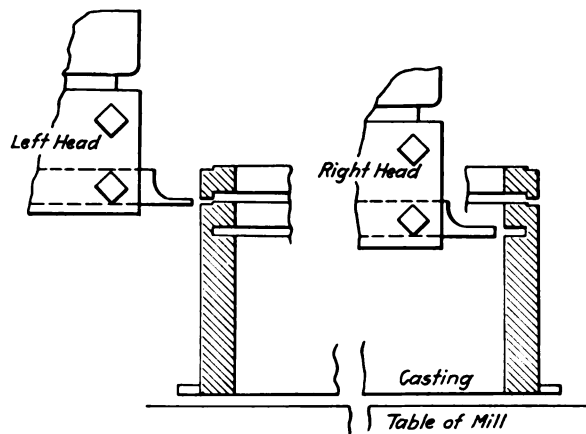

Fig. 2—Method of Cutting Off Z-Shaped Packing Rings for Piston Valves

carefully machined and the saving in engine failures more than makes up for the extra cost of machining the rings one at a time.

We are operating passenger engines 65 miles per pint of super-heater valve oil and we have a test engine that has made over 300,000 miles with one set of valve and cylinder packing rings. We average 125,000 miles for valve packing, or in other words, our engines usually run from shopping to shopping. When you consider the expense in the roundhouse for removing and applying valves due to their having been reported blowing, etc., it is well to look into the following suggestions for maintaining valves. The valve rings should not be turned over 1/16 in. larger than the valve chamber, preferably 1/32 in. if the rings are made from good iron and the valve chamber and packing is smooth. If the rings are turned too large for the valve chamber the ring is oval when it is placed in the chamber and bears heavy on two points, causing the locomotive to "blow" slightly; this blow means more lubrication and the burning of unnecessary fuel. In addition to this the ring will cut a shoulder on the valve bushing.

Valve chamber bushings should be bored every time the engine receives general repairs. If it is necessary to renew valve bushings, they should be left small enough so that they can be re-bored after they have been placed in position. It is a hard matter on our present two bushing type cylinders to draw them into the chamber exactly parallel, and unless they are parallel the valve will not work freely and this is the cause, in most cases, of so many valve rings being broken. The reason for re-boring all valve chambers at general repairs is that they are always worn at the port ribs and even if it is only slight, so it can hardly be noticed, it will cause trouble. On high speed engines, when

* Entered in the Piston Valve Packing Ring Competition, which closed October 1, 1915.

valves travel very fast, these worn places cause the rings and the valve to jump, which is the cause of most of the valve trouble. If this were followed up more closely a greater saving could be made in locomotive operation.

QUADRUPLE TOOL FOR PLANING SHOES AND WEDGES

BY E. A. MURRAY

Master Mechanic, Chesapeake & Ohio, Clifton Forge, Va.

The methods used in machining shoes and wedges at the Chesapeake & Ohio shops at this point differ somewhat from ordinary shop practice. Special planer tool holders are used

the inside tools to be raised when finishing wedges. The adjustment of the main head for both shoes and wedges is clearly shown in one of the illustrations, which shows both classes of work set up on one machine.

It will be noted that the tool post studs extend considerably beyond the face of the special tool. This extension is used to provide a holder for the tool which is used for the purpose of finishing the bottom of the frame fit after the flanges have been finished.

The chucks on which the shoes and wedges are set are box castings on the upper faces of which are placed a number of T-head bolts. These bolts are tightened from the bottom, and the heads are roughened to prevent the ends of the castings which bear against them from slipping when clamped in place

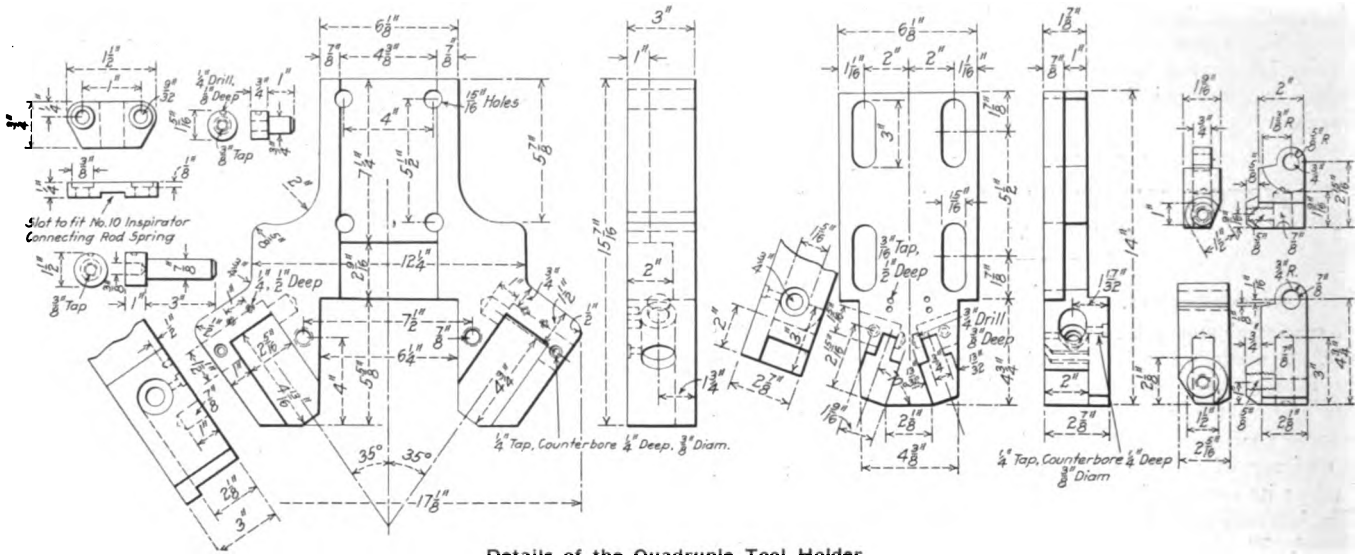

Details of the Quadruple Tool Holder

which permit the finishing of the two flanges both inside and outside at the same time, and both shoes and wedges are set up on a chuck which securely holds them and requires very little work in setting and clamping.

The main head, which fastens on the tool post proper, contains four auxiliary tool posts and four cutting tools. The construction of this head, as shown in detail in the drawing, is

by the set screws at the end of the chuck.

This device was developed by a machinist in the shops at this point, and has made it possible to finish cast-iron shoes and wedges at a cost of from six to seven cents each. The work is done on an old Niles planer with a 60 in. by 20 ft.

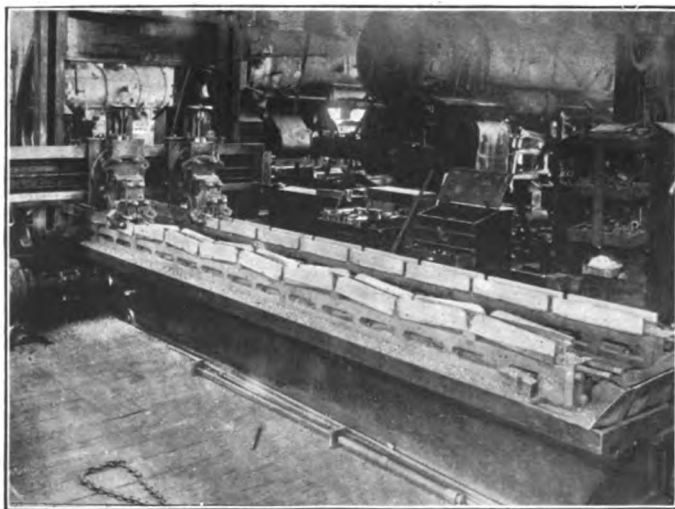

Method of Setting Up Shoes and Wedges on the Planer

in two parts. The part containing the outside cutting tools is secured directly to the tool post of the machine, and above this is placed the part containing the inside tools. The bolt holes in this are slotted for vertical adjustment, thus allowing

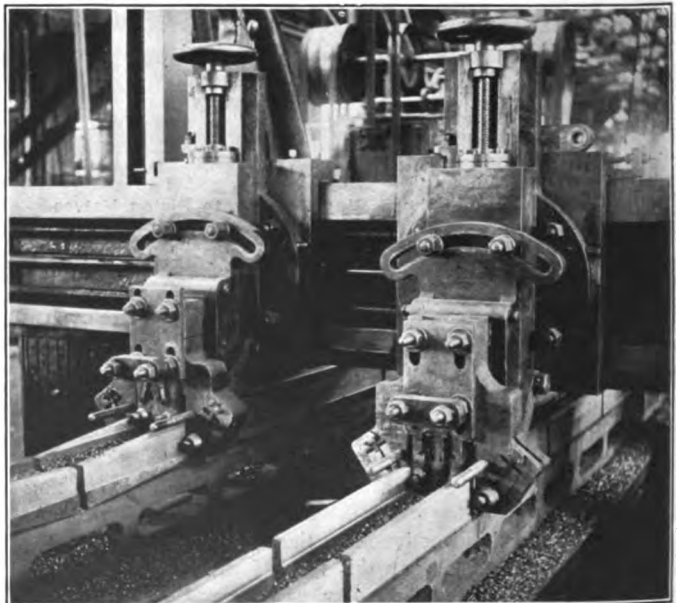

Method of Adjusting Tools for Finishing Shoes and Wedges

bed, and only one setting is required to finish all but the driving box faces of the castings.

STANDARDIZATION OF CRANE MOTORS

At the eighth annual convention of the Association of Railway Electrical Engineers, held at Chicago, October 18-22, a report was made on the standardization of crane motors. The committee, of which H. C. Meloy, New York Central West, was chairman, made a study of the existing conditions of traveling crane equipment in railway shops and found matters in a rather chaotic condition, so far as any attempt at the standardization or uniformity of a motor sizes is concerned. The capacities of the cranes vary from 1 ton to 150 tons, and between these limits there are 25 different sizes. The motor horsepower for the main hoist, bridge and trolley movement for the cranes of definite capacities also showed a great variation.

After carefully analyzing the problem with a view to fully meeting the needs of the modern locomotive repair shops and at the same time reducing the number of different crane capacities to a minimum, the committee suggested the following nine crane sizes, the capacities being in tons: 2, 5, 10, 15, 30 (single and double trolley), 60, 75, 120 (double trolley), 150 (double trolley). The 30-ton, 50-ton and 120-ton cranes each having the double trolley hoist, will actually reduce the number of sizes to the following: 2, 5, 10, 15, 30, 60 and 75. The committee also states: "There may be individual preferences on the part of many engineers for odd sizes of cranes, but it is no trade secret that odd crane sizes specified by railroad engineers usually are made up as a compromise equipment from a few standard sizes, and not always with the best results for either the crane manufacturer or the railroad company."

It would seem that the crane sizes recommended will readily take care of practically all conditions of shop operation, as follows:

- 2-ton crane for machine bays.
- 5-ton crane for machine or erection bays, material yard, etc.
- 10-ton crane for machine or locomotive bays, blacksmith shop, yards, etc.
- 15-ton crane for the boiler shop.
- 30-ton crane for the boiler shop.
- 120 and 150-ton cranes (60 and 75-ton hoist) for locomotive erecting bays.

The committee also made a study of the operating speed of the main hoist, bridge and trolley movements of the various sizes of cranes. From the data obtained from the manufacturers of cranes, the average hoisting speed for the different sizes was found to be as follows:

2 ton.....	35 ft. per minute
5 ton.....	30 ft. per minute
10 ton.....	25 ft. per minute
15 ton.....	20 ft. per minute
30 ton.....	20 ft. per minute
60 ton.....	8 ft. per minute
75 ton.....	7 ft. per minute
120 ton.....	8 ft. per minute
150 ton.....	7 ft. per minute

Regarding the bridge travel speed, the manufacturers commonly employ a formula of 60 lb. tractive effort per ton of weight; this is liberal to allow for inaccuracies in the runway gage, excessive friction, etc. Although the information received by the committee was not complete, the data furnished for bridge traveling speed is approximately as follows:

2-ton crane.....	150 to 300 ft. per minute
5-ton crane.....	300 to 350 ft. per minute
10-ton crane.....	250 to 300 ft. per minute
15-ton crane.....	250 to 300 ft. per minute
30-ton crane.....	200 to 250 ft. per minute
60-ton crane.....	150 to 200 ft. per minute
75-ton crane.....	150 to 200 ft. per minute
120-ton crane.....	150 to 200 ft. per minute
150-ton crane.....	150 to 200 ft. per minute
Trolley or cross trolley speed; 5 and 10-ton cranes,	125 to 150 ft. per minute;
15-30, 100 ft. per minute; 60-75 and 120-150,	80 ft. per minute.

The data for the sizes of the main hoist motors is also tabulated below, but the committee pointed out that it was not to be considered as a recommendation, as further investigation should be made:

5-ton crane.....	14 horsepower
10-ton crane.....	22 horsepower
15-ton crane.....	25 horsepower
20-ton crane.....	31 horsepower

25-ton crane.....	35 horsepower
30-ton crane.....	38 horsepower
40-ton crane.....	45 horsepower
60-ton crane.....	57 horsepower
75-ton crane.....	60 horsepower

The committee did not feel justified in making any definite recommendations, but it is the desire to standardize not only the motor sizes, but the motor outlines, phase templets, motor shafts and key weights. The great advantage of such standardization in crane motors would be the reduction in the number of spare parts to be carried in stock and the greater ease in making repairs or replacements.

START THE APPRENTICE RIGHT*

BY AN OLD-TIMER

Of late years the average apprentice boy who starts an apprenticeship does not do so from the desire to become a good mechanic in his chosen trade, but takes it up simply because it is a "job." Most persons are misplaced because they choose their work in a haphazard way when they start out in life. They and their employers waste years in the "trying-out" process. Starting right is the root of the whole matter. The average apprentice boy is incapable of self-analysis and the best way to help him is to try him out to see if he is really interested, or will become interested as he advances. It is a fact that the first six months of his shop experience is a good criterion of what his conduct will be during his apprenticeship.

There are many ways of stirring up the necessary interest in a boy, chief of which is the extensive apprentice instruction schools, but in a shop which has no special instruction for apprentices I believe the best way to help them succeed is to start them right. By this I mean that some certain good, honest mechanics should be selected to handle every apprentice when he first starts his trade.

Take a young man who starts to work the first morning with a new pair of gloves on his hands and let him work with a good mechanic who has been through the mill and has found out that gloves are not necessary—in fact are a hindrance to accurate work—and it won't be long before the boy will throw his gloves away. This training is invaluable, for once a boy finds he can work without gloves he will never buy another pair. I speak of this one item for I notice that boys to-day are too anxious to keep their hands soft and white, and will sacrifice their reputation for quantity and quality of work to protect their hands. One of the very first things that an apprentice should learn is that he is engaged in labor that will toughen his hands and that a good mechanic can be picked by the condition of his hands.

Another great help to an apprentice boy is to teach him promptness. Take a boy that gets to work at the last minute and gets ready to go home five minutes before the whistle blows at noon or night, and you will find he isn't one of the best mechanics in the shop. I believe an apprentice should be taught to be on time in the morning and do a faithful day's work. Very often we hear the argument that an apprentice gets such small pay that he shouldn't work very hard. When you hear an apprentice talk like that you can safely say that he is not interested in his work.

When I was an apprentice I liked some jobs so well that I could hardly wait for the night to pass to start at the work again. I worked for a foreman who was interested in his work and he seemed to instill interest in me also. Very often we had disagreeable jobs to do, but the foreman would come around with a smile and tell us the quicker we completed the hard job the quicker we would get a better one. By these methods our foreman was known as a "real" man, for he had a kind word for everyone.

This suggests the thought as to how an apprentice should be

*Entered in the prize competition on "How Should Car Inspectors Be Trained and Developed, and What are Their Qualifications?" which closed October 1.

treated by his superior officers. The best way to help and encourage a boy is for the general foreman or shop superintendent to occasionally speak to him in the shop and question him about his work. Boys look on their superior officers as the "great" men of the shop and when the boy finds out that he is noticed he will try all the harder to support his officers. Take, for instance, the study of shop accidents. Many serious accidents can be traced directly to some careless workman, so why neglect your young coming mechanic and let him get into careless habits? I say that the time of a general foreman or shop superintendent cannot be put to any better advantage than by giving the young apprentice a short talk on safety ideas. We would be very proud to have the President of the United States stop us on the street and converse for a few minutes, and the average apprentice holds his shop superintendent in the same esteem as we do the President.

Another great help is to change the boy frequently from one class of work to another so that he will not go "stale." A young man who is very active picks up ideas rapidly, in fact, quicker than we realize, and in order that he will not lose his interest, I believe he should be changed from one department to another frequently. The benefits from this system are many, for if the boy does not catch on quickly, he is not interested, and if not interested, will make only an ordinary mechanic.

Another benefit of this system is that the boy will cover the ground long before he has completed the required time of his apprenticeship, and can be tried out alone on a job. The real test of a good mechanic is the way he handles his work and while a boy may be a perfect apprentice, he may be a failure as a mechanic when he is placed on his own resources. The best way to help the older apprentice is to let him work alone, or give him a helper and try him out on regular mechanic's work. An apprentice will not have some experience on every class of mechanical work while serving his time; as an apprentice he is taught only the simple rules of his trade. To be a successful mechanic he must learn to use his head and to keep his eyes open.

In summing up, if the boy is started right and is taught to observe things and is treated like a man, it is the best and only way to help him become successful in his chosen trade.

EXHAUST PASSAGE DRAIN VALVE

The illustration shows a simple automatic drain valve for use in cylinder exhaust passages which was developed by A. L.

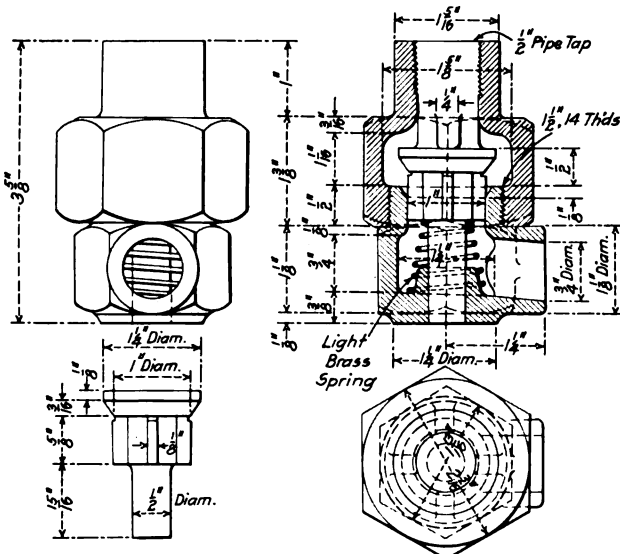

Automatic Drain Valve for Cylinder Exhaust Passages

Graburn, mechanical engineer of the Canadian Northern, Toronto, Ontario. The body of the valve consists of two sections

the upper one of which is attached either to the wall of the cylinder casting or to a pipe connecting it with the exhaust passage. Into this is threaded the other section which contains the outlet from the valve and a coil spring of light brass wire just strong enough to lift the check valve from its seat but permitting it to close positively under steam pressure. The valve has a lift of about 3/8 in., which is limited by lugs cast in the upper part of the top section of the casing. The valve is guided by a 1/2-in. stem passing through the lower part of the casing and also by four wings just under the valve disc.

PNEUMATIC HAMMER

An ingenious and serviceable air hammer has been devised by William Baird, shop superintendent of the Plattsmouth, Neb., car shops of the Chicago, Burlington & Quincy, for welding bolts and for hammering out scrapped rods to rods of smaller diameter. The photograph shows one of these hammers located adjacent to a furnace and used for welding bolts. At the base

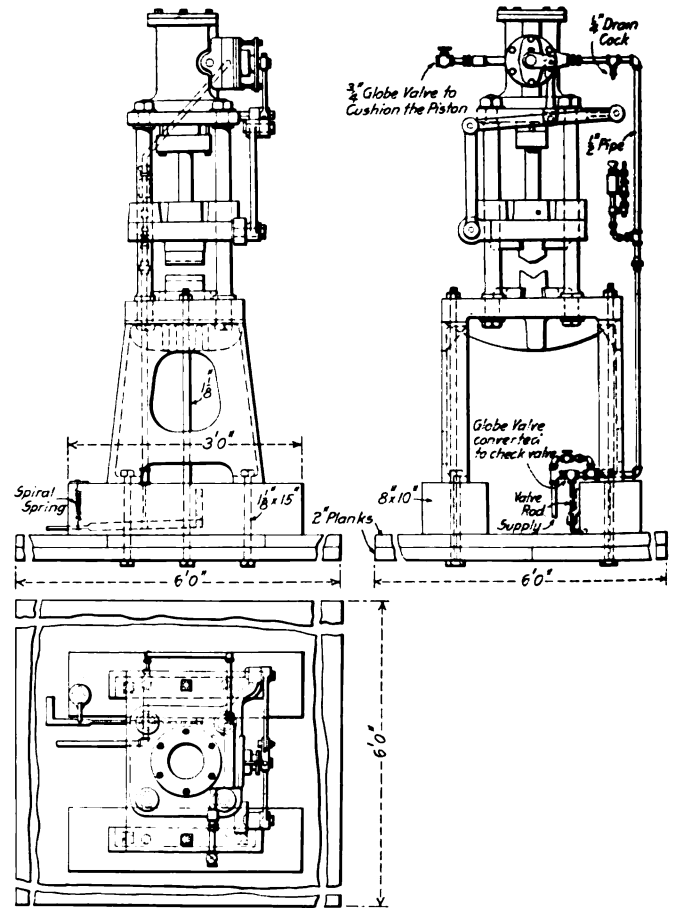

Pneumatic Hammer Assembled

of the hammer, resting against a pillar block, may be seen the two pieces of a bolt before it is welded and a finished bolt. The iron is scarfed in the cutting and the heads are heated in one side of the furnace and the ends in the other. They are simultaneously removed by the operator and his helper, placed in the proper position under the hammer and welded. The hammer operates at a speed of 250 strokes per minute and 650 bolts are welded in an eight-hour day. Bolts from 7/8 in. to 1 1/4 in. are handled in this machine.

The construction of the machine is shown in the drawing. The cylinder is supported on four columns, 2 1/4 in. in diameter. These columns are bolted to an anvil block 18 in. by 28 in. by 3 in. thick, which is reinforced with a 3-in. rib. running length-

wise of the block. This block rests on a cast-iron frame, which in turn is bolted to two pillar blocks, 8 in. by 10 in. These blocks are again bolted to a base 6 ft. square made up of two courses of 2-in. planks.

The cylinder has a bore of 6 in. and provides for a stroke of about 10 in. The piston is $2\frac{5}{8}$ in. thick, being designed for three

ENGINE FAILURES, THEIR CAUSES AND CURE

BY J. E. ANDERSON

General Foreman, Erie Railroad, Susquehanna, Pa.

I have read with much care and interest the report on round house efficiency presented at the General Foremen's Convention recently held in Chicago, which concludes by stating that, "perfect organization in a round house is the cure for engine failures." A great many exhaustive articles on the prevention of engine failures have been written and it has always been standard practice to place the entire blame for all failures on the engine house foreman; and many a man holding this position and possessing exceptional ability has been retired, due to his inability to overcome engine failures which he was in no way responsible for and which continued with uninterrupted regularity long after he ceased to exist as a foreman. The reason for placing the blame on the engine house foreman is perfectly natural from a transportation department standpoint, due to excessive delays to trains on the road, caused by engine failures, which result in endless confusion and expense to that department and for which there is no apparent excuse whatever.

Visualize for a moment a busy division on a trunk line handling heavy traffic, and consider what it means when the road is lined with trains to have an engine break down at a point where it is liable to tie up traffic for hours. The effect is demoralizing and the loss to the company heavy, due to large amounts paid for overtime to the engine and train crews affected. Where passenger trains are seriously delayed and important connections missed, there is a loss in business that cannot be computed. A passenger who has suffered on account of delays of this nature will not only refuse to take a chance on that line again, but is apt to advertise his experience to others and this is bound to affect the ticket sales. The failure is known to everyone from the president down, and since the engine is supposed to be maintained in the round house, it was evidently dispatched in an unserviceable condition by the engine house foreman; he is therefore naturally looked upon as the guilty man. While we are prepared to admit that a clear engine failure board means that there is a perfect round house organization behind it, a perfect round house organization does not necessarily mean a clear engine failure record. As a matter of fact, it is possible to have a thoroughly efficient engine house organization, and yet be constantly confronted with numerous engine failures, and if the master mechanic referred to in a recent editorial in the *Mechanical Edition*,* who stated that 99 per cent. of the failures on his road were due to his round house organization, was literally stating a fact it must be assumed that the many other conditions which usually contribute to failures, over which the round house has no control, do not exist on his road, and if this is the case, he ought to recognize the importance of applying a remedy, as he alone is responsible. He is in supreme command of his engine houses, and tolerating an imperfect organization is equivalent to admitting his own inability to perfect it.

One of the causes leading up to engine failures, which exist to a greater or less extent on most of the railroads, for which the engine house foreman should not be held responsible, is the pooling of power, and running engines first in, first out without an assigned engine crew; compelling the foreman to keep them going and criticizing him for not turning engines promptly on arrival. This is extensively practised on many roads, and some of them have fixed a time limit of two and one-half hours from the time engines arrive on the ash pit until again attached to a train. Oftentimes, when an engine has made a successful run over the division and the dispatcher sees that it will arrive at about a certain time, he will notify the engine house of the fact, and instruct that a fresh crew be called to

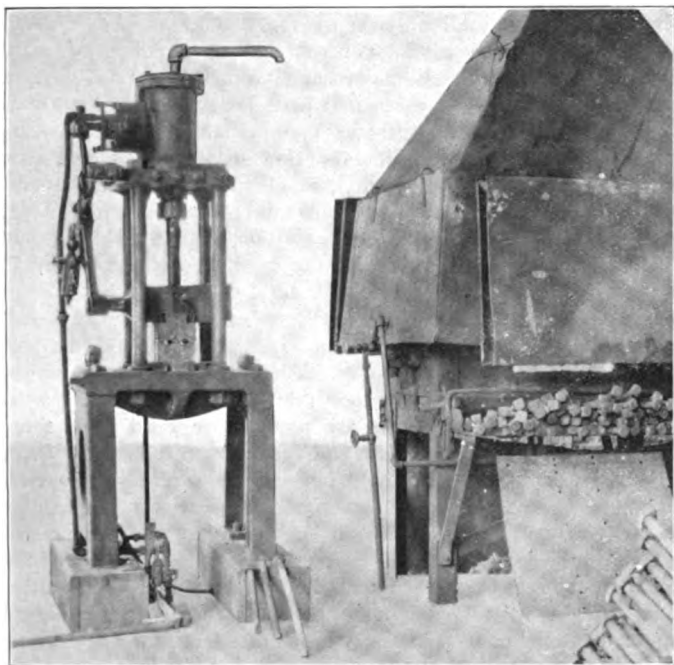

Pneumatic Hammer for Welding Bolts

packing rings $\frac{3}{8}$ in. thick. The piston rod is $2\frac{1}{2}$ in. in diameter and has a taper fit in the hammer. The air supply to the cylinder is regulated by a rotary valve, operated by the link motion shown in the side view of the hammer. The valve itself is also shown among the details of the machine. It has one blind and one open chamber which alternately cover the ports A and B, shown in the side view of the cylinder. The port C is the exhaust and is constantly under the blind chamber of the rotary valve. Air is admitted to the cylinder from the valve chest through the open

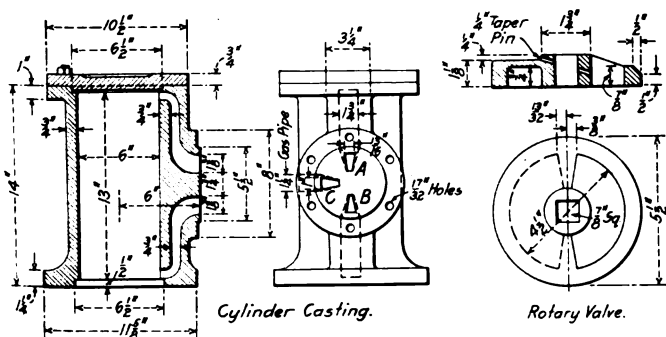

Cylinder and Rotary Valve for Pneumatic Hammer

chamber and the ports A and B. The exhaust pipe is provided with a globe valve for the purpose of restricting the exhaust sufficiently to give a cushioning effect to the piston at the end of the stroke. The air to the valve chest is controlled by a pedal valve at the base of the machine. This valve is by-passed for the purpose of keeping a constant pressure under the hammer, thus holding it in its "up" position when it is not working.

EFFICIENCY OF SMALL TURBINES.—The highest commercial efficiency of small steam turbines is said to be about 40 per cent.

* Editor's Note: The editorial referred to appeared on page 395 of the August, 1915, *Railway Age Gazette, Mechanical Edition*.

take the engine back immediately on arrival. If the foreman hesitates, the case is explained to the master mechanic, who advises the foreman to get busy and hurry the engine out. It is difficult to see how any round house organization can exercise a restraining influence on engine failures when methods of this kind are followed. Again, it is a common practice on many roads for train masters and general yard masters, when ordering power of the engine house and not getting it at just the hour demanded, due to important repairs that the foreman deems advisable, to wire the superintendent the numbers of the engines held which are refused by the foreman, omitting, however, to give the reason for holding them. The result is that the master mechanic's office is advised of the dilatory conduct of the foreman, who is immediately wired by his department that the orders for power must be filled at once. The 100 per cent round house organization will not act as an engine failure deterrent under such conditions.

Another prolific case for non-performance of engines is traceable to the back shop. The enterprising shop superintendent being saturated with a desire to boost his shop output and incidentally beat his predecessor's record for engines overhauled, engines are taken into the shop, hurriedly gone over, given a part set of flues, the rods, motion work, and driving boxes refitted, the tires turned, the engine painted and returned to service to start new mileage. No attention is given to truing up the journals or crank pins, valve chambers or cylinders. The frames are not touched and a score of important operations that should never be ignored are allowed to go undone. The round house getting these engines has its work cut out for it in keeping them off the failure board.

Lack of co-operation on the part of the road foreman is another cause for a class of failures that never would occur with the right man on the job. By keeping the engine house foreman posted on engine performance and by educating the younger men to get over the road under adverse conditions many failures may be avoided.

Nothing is more conducive to engine failures than the loss of the engineers' support, brought about usually by persistent nagging over trivial offenses. Disciplining a man for an error in judgment, or omitting to perform some duty of an unimportant character, is sowing the seed of discontent among a class of men that can work more harm to the mechanical department of a railroad than any other one cause. The writer distinctly recalls a case of an engineer who had some grates burned out, and seeing a chance to get some fish plates from a section house, secured the material required, made temporary repairs and brought in his train without a failure. The case was reported by the road department, investigated and the engineer suspended for ten days. I never heard of any further effort on his part to prevent failures, but I did hear him boast of one he had which tied up his road for hours, and which there is reason to believe he could have avoided. The engineer is master of the situation after leaving the terminal, and the better satisfied he is with his working conditions the greater exertion he will make to keep down failures.

Another frequent cause for charging failures is due to the overloading of engines on long and hard divisions under bad weather conditions by the transportation department, the failure being charged to avoid a violation of the sixteen-hour law. The use of material of a poor grade is often the cause of failures of a disastrous nature. Weakness in the design of parts is another cause of numerous failures for which the foreman is more or less criticized.

Possibly no one thing has a more disastrous effect on round house organization than a lack of harmony between the master mechanic and the engine house foreman. The master mechanic who has not served as engine house foreman himself cannot appreciate what it means to hold that position, and is apt to have a pessimistic view of things in general in the round house. Conditions in the round house often change within a remarkably

short space of time from perfect order to a complete state of chaos, due to any one of a score of unexpected occurrences which the engine house foreman must be big enough to meet. Such conditions are unknown in a back shop, and the man who receives his training in the back shop naturally has but little sympathy for the irregular operations in the round house.

Remarkable results have been obtained on the Erie Railroad in eliminating engine failures. These results are due, in the first place, to a total absence of the conditions above noted which the foreman cannot control, and to a policy of rigid inspection and thorough maintenance which is carried out at all times. Unlike some roads where heavy traffic conditions are not constant, which permits the mechanical department to prepare for the heavy business during slack periods, the Erie handles a heavy volume of traffic at all times, and it is imperative that power be maintained constantly at the highest point of efficiency. The Susquehanna division, 140 miles long and handling the heaviest traffic on the road, has a record of 75 days without a passenger engine failure, during which time approximately 200,000 miles were made. During the same period, a record of 38 days with but one freight engine failure was made, representing 250,000 miles. These results have an added significance when it is understood that the rules governing what constitutes an engine failure are much more rigid than those laid down by the various state and federal governments. When an engine arrives at the round house, it is carefully inspected, and repairs made before it is returned to service. The engine house foreman is the man who decides when the engine can go, and as he is held wholly responsible for its performance it is of vital importance to him to know that it is in serviceable condition before allowing it to go. All engines are assigned to regular crews; if at times it is impossible to hold an engine until the crew have had their rest, they are deadheaded to the other end of the division for the engine. In each roundhouse there is a framed list of instructions, consisting of 53 operations which are performed at boiler wash periods. These are extraordinary inspections such as crosshead fits, valve and cylinder packing, removal of all trailer and tank wheel bearings, removal of drawbars and pins, testing superheat units, etc. In addition, a special inspector goes over the engine and reports in detail his findings. Each class of the work is handled by specialists. Each operation is recorded in a book for the purpose by the man in charge of the work. This enables the foreman to keep in touch with what is being done at all times, and gives him a line on what material is being used and if excessive amounts, it is seen at a glance and steps taken to correct the bad condition.

Engineers know that their engines will be held at these periods, and figure accordingly on the work they want done. When repairs are completed, the engine under ordinary circumstances can be relied upon for the rest of the month, and can be turned, usually, as promptly as required. As all engines taken in the back shop are given a thorough overhauling down to the smallest detail it is possible to obtain exceptionally high mileage between shoppings.

STORING STEAM AT THE ENGINE.—Storing steam at the engine instead of at the boiler was accomplished by placing large receivers and separators near the throttles of reciprocating engines recently installed in the power house of a western mining company. At the same time the boiler drums installed at the plant were made unusually small, as the company's engineer declared that the proper place to store steam is at the engine throttle and not in the boilers. The receiver capacity at each engine is practically four times the cylinder capacity, and this steam reservoir permits the use of smaller steam piping, thereby reducing heat losses and establishing at the same time a reserve supply of dry steam immediately at the engine throttle, where it is most needed under the condition of an engine engaged in mine hoisting.—*Electrical World*.

CHUCK FOR FINISHING AIR PUMP PACKING RINGS

BY F. R. STEWART

There are a variety of opinions as to the best method of finishing packing rings. Some consider grinding on a magnetic chuck to be the only proper way to insure a true face, others

this jig from 200 to 250 rings can be faced in 10 hours, and every one will gage perfectly at any position.

MACHINE TOOL LUBRICANT PUMP

An interesting arrangement in use at the Sedalia (Mo.) shops of the Missouri, Kansas & Texas for pumping lubricant to the

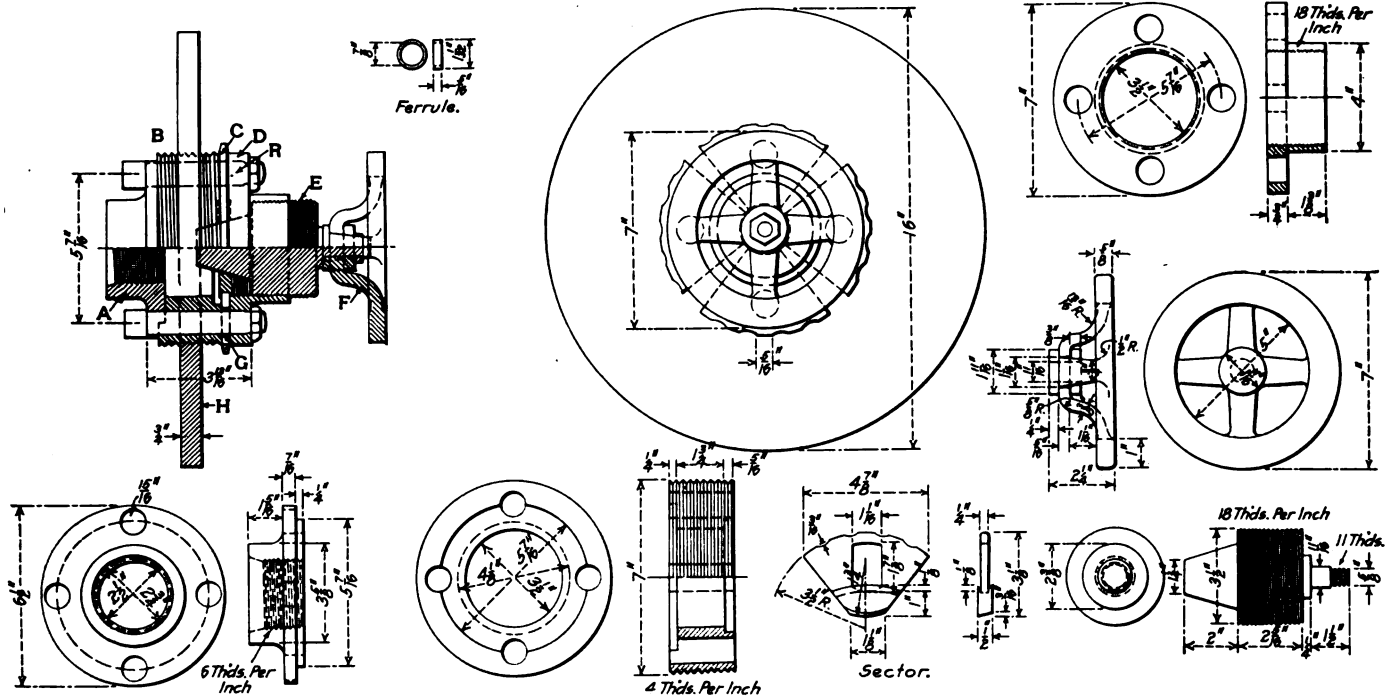

Chuck for Finishing Both Sides of Packing Ring at the Same Time

claim that facing one side at a time in a split bushing gives the best results. From a close observation of both methods it will be found that the chucking of the casting from which the rings are cut necessarily distorts it, and after the rings are cut off, with a fraction of an inch of stock for finishing, the chucking strain is relieved and the result is a warped ring. If this ring be drawn down and faced on a magnetic chuck the same warp will appear when the influence of the chuck is removed. The principle is exactly the same if the ring is crowded into a split bushing and faced. When the holding force of the bushing is relieved the ring will be more or less warped and will rock on a face plate.

The drawing shows a device which overcomes these difficulties by facing both sides of the ring at the same time, and any irregularities in the ring are faced off without chucking strains. Referring to the sectional view of the assembled jig, plate A fits the spindle of the lathe, and to it the parts B, C and D are bolted by means of the fitted bolts R. Segments C are free to move on the steel ferrules G.

The operations necessary to chuck a ring are as follows: Revolve face plate H on disc B to square up the packing ring, which is placed over the four segments C. Tighten the ring by turning the wheel F clockwise. When the packing ring is sufficiently tight, start the lathe, and back the face plate toward the head stock of the machine; this will allow both inside and outside faces of packing ring to be cut at the same time by means of a forked tool. The segments are so constructed that their width is 1/16 in. less than the finished width of the packing ring.

The face plate can be made large enough to include the largest size ring, it being only necessary to have a set of segments for each inch increase in packing ring diameter. On

various machine tools for use in cutting operations is shown in the photograph. The pump consists of two air brake cylinders

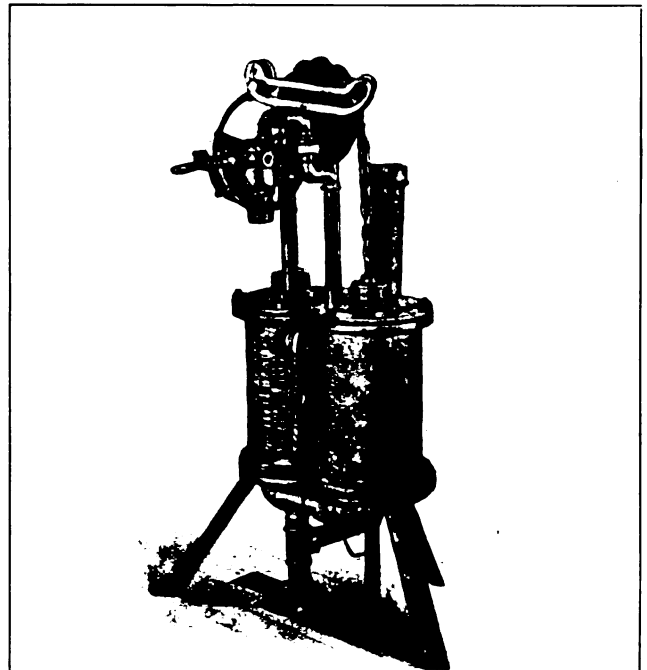

Pump for Machine Tool Lubricant

placed back to back. They are actuated from the shop air line system, which delivers the air through a three-way cock to the

upper part of the cylinders. As the pressure is applied the piston descends, forcing the lubricant through the lubricating system. The piston in the other cylinder being connected by a chain over a sheave to the descending piston rod is drawn to its upper position and at the same time draws in a charge of lubricant. The air valve is actuated by a rocker on which a revolving weight travels, which, as the arm is raised, by a contact on the sheave, throws the valve over to either extreme position, admitting the air to one cylinder and releasing it from the other. The system is entirely automatic, inexpensive to make, and has given good results.

HIGH SPEED STEEL TIPPED TOOLS

At the recent convention of the Tool Foremen's Association, J. W. Pike, tool foreman of the Chicago, Rock Island & Pacific, at Silvis, Ill., spoke of the success that had been attained at Silvis by welding high speed steel tips on shanks or holders made of axle or tire steel and sometimes old taps and dies. In the latter case the twisted portion of the drills and the threaded portion of the taps are heated and hammered to the proper size and shape. The tools 5 and 6 in the accompanying illustration are made from drills, and tools 12 and 13 are made from old taps; in both cases these tools are not finished. The drills and taps 1, 2, 3 and 4 are to be made over into high speed steel tipped tools.

The high speed steel tip is shown at 7 A. The tips are made in the dies 8 and 9. The impression in the dies is stamped under the hammer with a piece of steel shaped to the required size, the die blocks being heated sufficiently to be easily depressed under the force of the hammer. The body of the tool

the parting, threading and turret lathe tools in this way. By following this method the cost of tools has been materially decreased.

TEMPERING TOOLS WITH THE ELECTRIC FURNACE

The committee on Shop Practice of the Association of Railway Electrical Engineers, in its report at the last annual convention, strongly favored the use of the electric furnace in tempering tools, claiming that the life of the metal would be increased because of the ease with which it is possible to control and determine the temperature of the electric furnace. Regarding the cost of tempering by this means the committee reported as follows:

These costs are an average obtained from several different shops taken independently of each other and then compiled; although an average is used, in no cases were the limits of high and low costs greater or less than 10 per cent from each other. It will also be understood that costs of air are based on an electric-driven blower, current costing two cents per kilowatt hour and on such tools as require more than one heat to work them this is taken into account in determining the unit price.

Size		DIES	Labor to increase size	Retempering	Total
1/2 inch to 5/8 inch	Softening	.0383	.10	.041	\$.1793
5/8 inch to 3/4 inch		.0378	.112	.04	.1898
3/4 inch to 7/8 inch		.0371	.121	.04	.1981
7/8 inch to 1 inch		.0365	.142	.038	.2165
1 inch to 1 1/4 inch		.031	.161	.038	.23
1 1/4 inch to 1 1/2 inch		.031	.164	.038	.233

In making these figures, machinists' labor costs are assumed to be 40 cents per hr. and the blacksmiths' labor at 39 cents per hr.

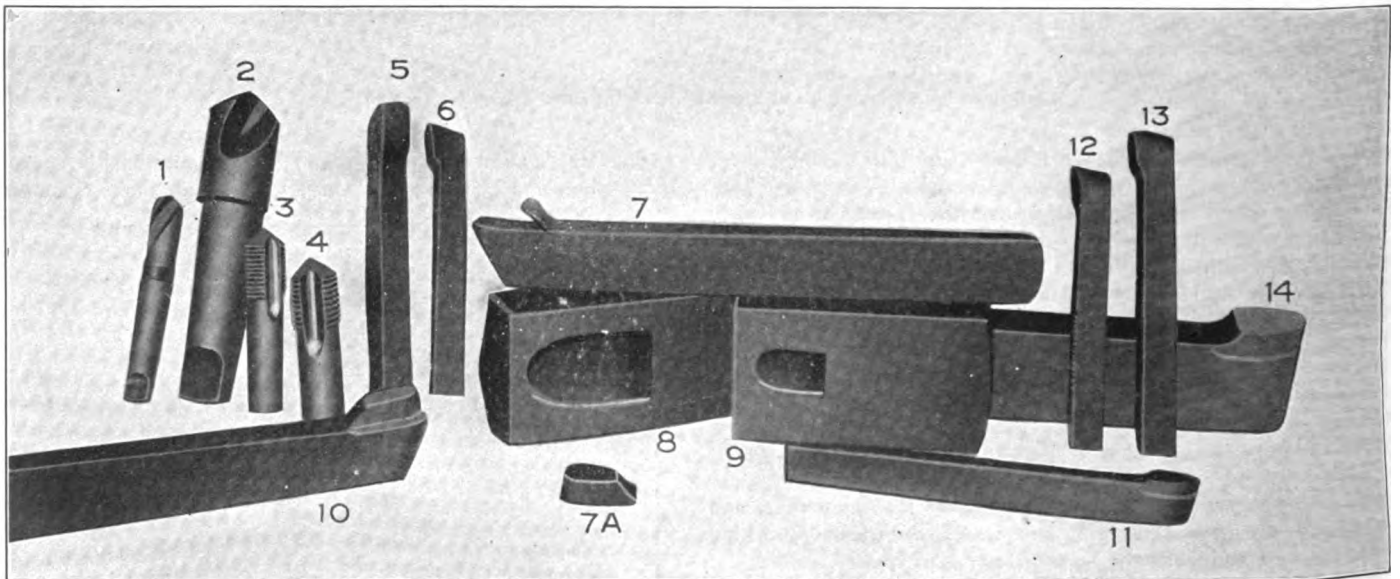

Group of High Speed Steel Tipped Tools with Dies for the Tips and the Tool Shanks

ready to receive the tip is shown at 7. A lip is prepared, as shown, to hold the tip in place while the welding heat is being taken, which is about 2,200 deg. The tip and the tool body are then pressed together until they are thoroughly welded. A 1,500-lb. hammer, a bulldozer, a forging machine, or a hydraulic press can be used, or any other means that will quickly give sufficient pressure to hold the tip firmly onto the body of the tool until fusion has taken place. It is found necessary to use a flux, and the E-Z welding compound has proven satisfactory. The finished tool, after being ground, is shown at 14. Nearly all kinds of machine tools can be made in this manner, such as tools for lathes, planers, boring mills, etc., from 1 in. by 1/2 in. to 2 in. by 3 in., but it has not been found practical to make

Size		TAPS	Labor of dressing	Retempering	Total
1 1/8 inch to 1 inch	Softening	.0423	.123	.0542	\$.2195
1 inch to 3/4 inch		.041	.119	.0540	.214

Size		MACHINE TOOLS	Tempering	Total
Small	Labor of dressing	.0633	.043	\$.1073
Large		.0825	.052	.1345

Very little information was obtainable on these.

Size		CHISELS	Tempering	Total
Small	Labor of dressing	.041	.032	\$.073
Large		.063	.052	.104

The last two items are usually of the best steel, and it is necessary often to make more than one heat to work them;

some of the costs collected under the head of "Chisels" are considerably higher than those given.

REMOVABLE WEDGE BOLT

BY H. E. OPLINGER

General Foreman, Atlantic Coast Line, Brunswick, Ga.

A simple removable wedge bolt designed by the writer and intended to permit the removal of the wedge bolt without taking down the pedestal binders, is shown in the drawing. The device consists of the bolt and two nuts, and requires a binder

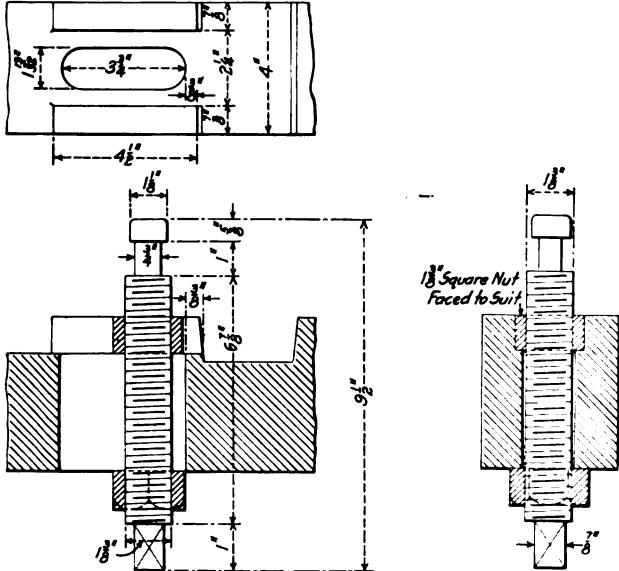

Wedge Bolt Which May Be Removed with Binders in Place

on the upper side of which are two shoulders, one on either side of the slot through which the bolt passes. The bolt engages the wedge in the usual manner and is secured in place by means of a special square nut which sets between the shoulders on the binder and an ordinary nut below the binder. The wedge is adjusted by slacking off the lower nut, when the bolt may be raised or lowered by turning it through the upper nut and is again locked in place by tightening up the lower nut. The bolt may be removed by sliding it out of the wedge and then screwing it out of the upper nut, the body of the bolt being threaded throughout its entire length.

SHOE AND WEDGE CHUCK FOR MILLING MACHINE TABLE

BY R. E. BROWN

Machine Shop Foreman, Atlantic Coast Line, Waycross, Ga.

The drawing shows a set of jaws in use on the milling machine table for clamping driving box shoes and wedges. The set con-

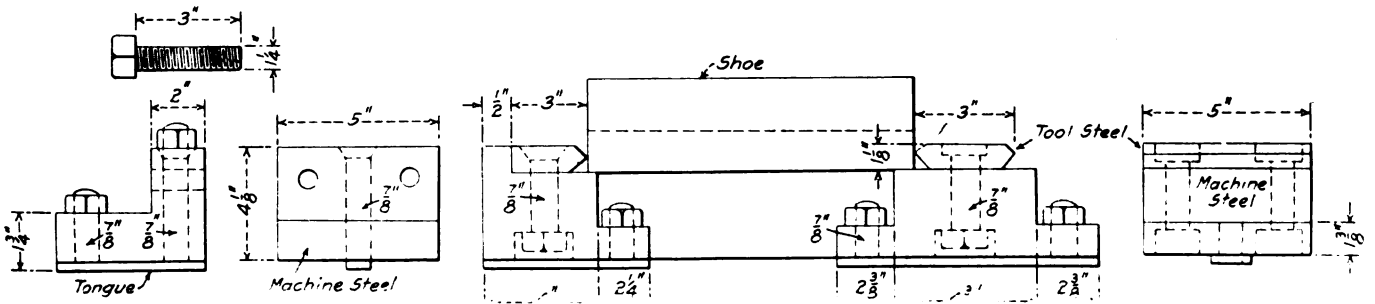

Tool Steel-Faced Jaws for Clamping Shoes and Wedges on Milling Machine Table

sists of five pieces and is designed to secure two shoes or wedges on the table for finishing at one time. By increasing the number

of intermediate pieces, however, the set could be made to take any number of castings.

The intermediate piece is bolted to the table and securely clamped, the end jaws being adjusted to suit the length of the shoes or wedges. The ends or angle pieces are placed close to the end jaws and are clamped to the table as tightly as possible and further secured by placing stop pins behind them. Set screws passing through the vertical walls of these pieces bear against the back of the end jaws and press the tool steel jaws into the ends of the castings.

Owing to the fact that this work is done on a light machine in the Waycross shops, but two castings are set up at one time, our experience having shown that we can do the work quicker in this way than by setting up six castings at once. On a heavy milling machine, however, if two rows of these chucks are used shoes and wedges may be finished from 3 to 4 cents each at a machinist rate of 41 cents an hour. In milling wedges one end of each wedge is raised by placing a block under it.

GAS BRAZING FURNACE

The drawing shows a neat home-made brazing furnace used by the Chicago & North Western at the Clinton shops, in which commercial gas is used as the heating agent. The furnace is 32 in. high, being made of 1 1/2-in. angle iron with a sheet

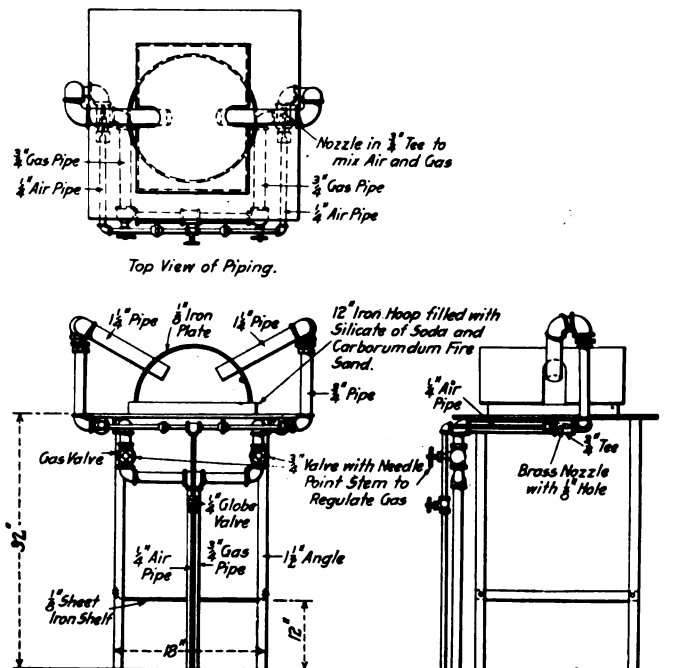

Brazing Furnace Using Commercial Gas

iron top and a sheet iron shelf 12 in. from the bottom. The gas is fed to the furnace through a 3/4-in. gas pipe, the flow

being regulated by a needle valve. The air used for mixing with the gas is taken from the shop line through a 1/4-in.

pipe, and is admitted to the gas line through a nozzle in a $\frac{3}{4}$ -in. tee, shown in the top view of the furnace. The blast which, as shown, comes from both sides of the furnace, is directed on to a bed of a mixture of silicate of soda and carborundum fire sand. A $\frac{1}{8}$ -in. curved iron plate forms the hood of the furnace, the ends being left open. The furnace is inexpensive to build, and has been found to work very satisfactorily where city gas is used in the shops.

HANDLING COUPLER YOKES

The photographs show three machines used for coupler yoke work at the Plattsmouth, Neb., shops of the Chicago, Burlington & Quincy. They are noteworthy because of the fact that but for their present use they would have been scrapped. An

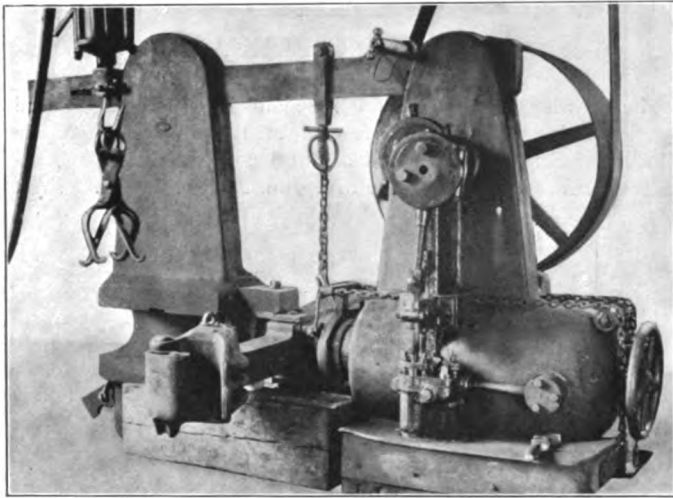

Fig. 1—Hydraulic Press for Removing Coupler Yokes

old hydraulic wheel press that has outlived its usefulness as such, and which is used for removing the yokes from couplers, is shown in Fig. 1. The yoke bears against a forked head in the outboard housing, and the plunger of the press pushes against the body of the coupler, thus shearing the coupler yoke rivets.

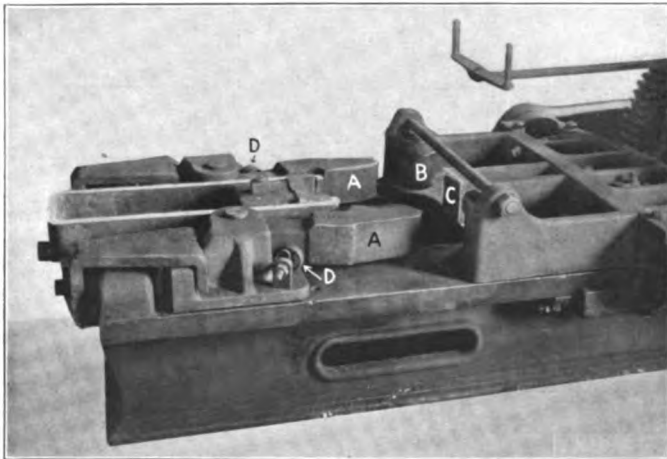

Fig. 2—Dies for Forming the Lips on Coupler Yokes

The method of forming the lips on the end of the coupler yoke in a bulldozer is shown in Fig. 2. The yoke, having been bent, is anchored to the bed of the bulldozer within the arm, *A*. As the head of the bulldozer travels forward, the rollers *B* force the arms *A* against the yoke, thus forming the lips. The plunger *C* shears the lips to the proper length. Both operations are per-

formed with one stroke of the head. The arms *A* are held in the open position by the springs *D*.

The machine used for riveting the coupler yoke to the coupler is shown in Fig. 3. It is a pneumatic riveter set into the floor

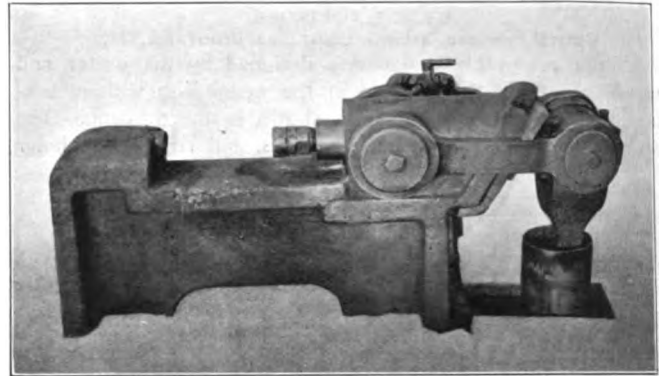
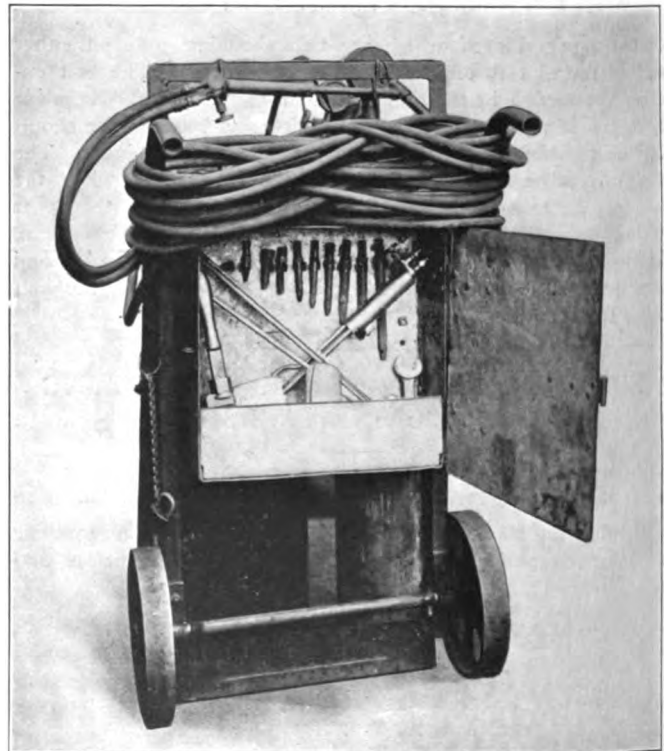

Fig. 3—Pneumatic Riveter for Riveting Yokes to the Couplers

of the shop as indicated and is operated by a three-way valve, shown just above the plunger cylinder.

PORTABLE OXY-ACETYLENE WELDING AND CUTTING OUTFIT

A truck for handling the oxygen and acetylene tank, and a cupboard containing the various tips, burners, wrenches, etc., used in oxy-acetylene operations in and about the shops of the New York Central Lines at Elkhart, Ind., is shown in the photo-



Complete Portable Welding and Cutting Outfit

graph. Everything that is needed for the work is carried with the truck, and there are no delays occasioned by operators being required to leave their work in search of necessary articles. The two tanks are set in the frame work of the truck and clamped in position. The handles are made of pipe and extend from the front of the tank rest diagonally across the frame of the truck. When not in use the hose is coiled around the handles.

NEW DEVICES

UNIVERSAL ELLIPTIC SPRING FORMING MACHINE

A Universal elliptic spring forming machine has recently been placed on the market by Jos. T. Ryerson & Son, Chicago. It is designed for railway spring shop use and will form elliptic spring leaves of any size and curvature within the limits of ordinary practice without changing dies.

The body of the machine is a heavy horizontal table supported on five legs. On one side of this table is a bank of keys which form the concave die against which the spring plates are shaped. The keys rest on edge side by side and are held in their forward positions by a series of counterweight levers which provide the necessary pressure to bend the hot plates. On an extension across the table from the keys is a pressure cylinder, a crosshead on the front end of its piston rod acting as the

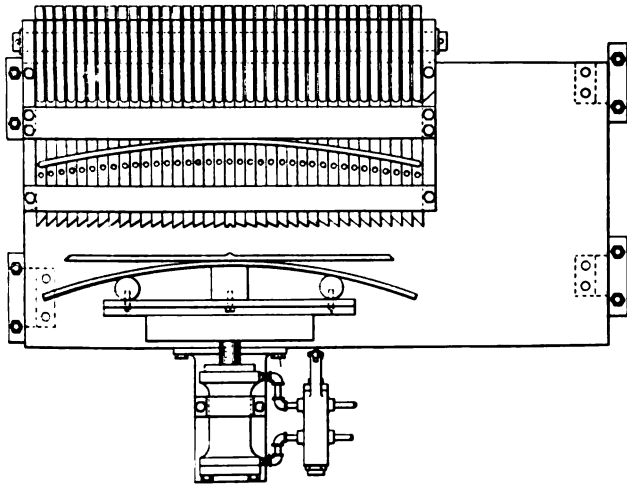

Plan of the Universal Elliptic Spring Forming Machine

convex die. On the face of this crosshead are mounted three blocks, the center block being stationary and the others adjustable in and out from the center. By the position of these blocks the curvature of the spring leaves is controlled. A valve

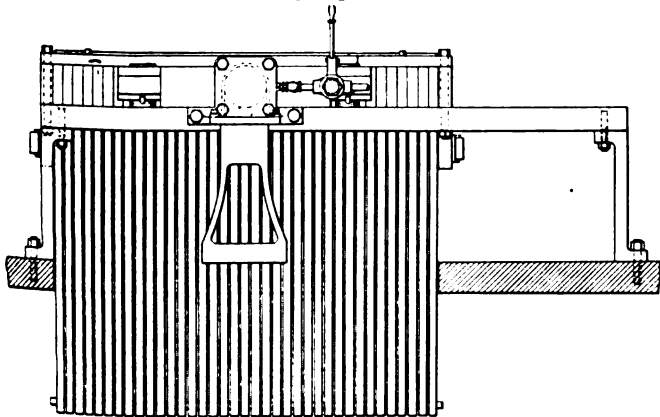

View of the Cylinder Side of the Spring Machine

for controlling the movement of the piston is placed immediately above the cylinder when compressed air is used and at the side of the cylinder when hydraulic pressure is used.

In operation the hot leaf to be formed and the cold leaf against which it is to fit in the completed spring are placed on

edge on the table with the cold leaf against the crosshead. Pressure is then applied to the piston until the two leaves are forced against the bank of keys, when the hot leaf will be bent to the exact curvature of the cold one as a result of the resistance offered by the counterweighted dies. If camber or tuck is desired between the leaves the two adjustable blocks on the crosshead are set to spring the cold plate slightly, thus causing the radius of curvature of the new leaf to be reduced sufficiently to give the desired amount of space at the center between the leaves. In many cases leaves come from the furnace which are not straight edgewise. These may be placed in

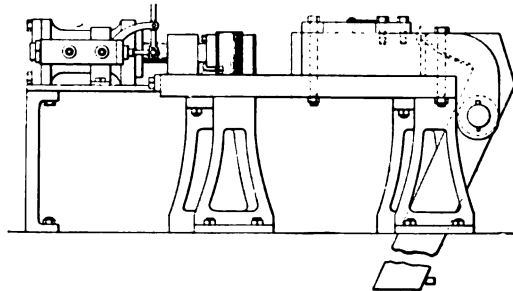

End Elevation of Spring Forming Machine Showing the Counterweight Levers

a horizontal position in front of the keys and straightened with one stroke of the crosshead.

This machine possesses a number of advantages, including simplicity and rapidity of operation as well as the uniformity of the work turned out. It does not require a high temperature in order to form the leaf and there is little danger of overheating the steel. This machine was developed by J. W. Riley, foreman blacksmith at the Sayre, Pa., shops of the Lehigh Valley.

AUTOMATIC DRIFTING VALVE

A drifting valve designed for use with superheater locomotives by means of which live steam is automatically admitted to the cylinders in small quantities when the locomotive is drifting, has been developed on the Minneapolis, St. Paul & Sault Ste. Marie. It has been used with considerable success on the Soo line's large superheater locomotives and patents have now been secured.

As shown in the drawing the valve is designed to replace the ordinary steam chest relief valve which it somewhat resembles in appearance. It consists of a two-part casing within which operates a piston valve with a hollow ring-packed stem. A $\frac{3}{4}$ in. extra heavy pipe from the steam turret in the cab is connected to the casing and admits steam to chamber *A*. A valve is provided in the cab to shut off the supply of steam to this pipe if desired, but in practice the valve is open when the engine leaves the roundhouse and closed when the engine reaches the cinder pit. Through ports in the inner well of chamber *A* steam is admitted to the annular space *B* surrounding the hollow stem of the piston valve *G*. So long as there is pressure in the cylinder and steam chest the piston valve remains seated in the position shown in the drawing. When the throttle is closed and the engine is drifting, as soon as a vacuum forms atmospheric pressure acting upward against piston valve through the ports *H* in the casing raises the piston $\frac{1}{2}$ in. which is the limit of its travel. This movement places the annular space *B* in communication with ports *C* through which steam from

chamber *A* passes into chamber *D* and thence through ports *E* to the hollow stem of the piston. The check valve *F* is raised from its seat and steam passes directly into the steam chest.

As soon as the engine stops or for any reason a slight pres-

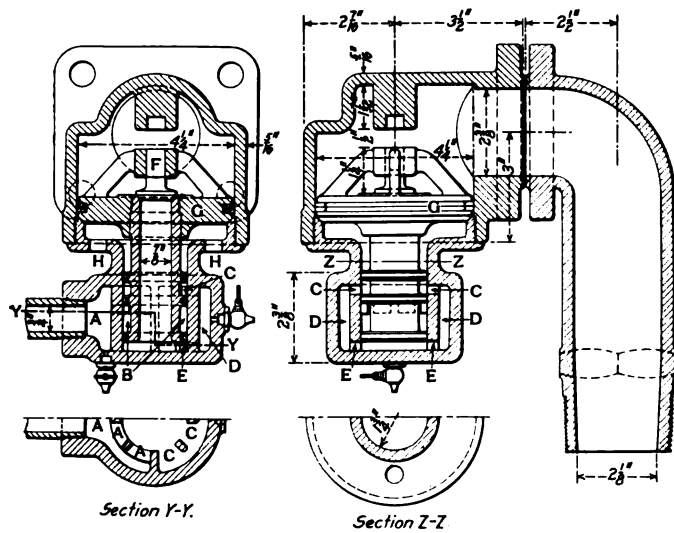

Drifting Valve for Superheater Locomotives

sure is formed in the cylinder the piston valve is forced downward to its seat, thus cutting off communication between the annular space around the hollow stem and chamber *D*. This valve has been found to greatly assist in the proper lubrication of cylinders where superheated steam is used.

CONDENSER VACUUM PUMP

The modern power house equipment invariably includes a condenser plant, the efficiency of which depends upon the degree of vacuum within the condensing apparatus. For maintaining this vacuum and for general service in other lines where a high degree of vacuum is desired, the Ingersoll-Rand Company, 11 Broadway, New York, has recently introduced a complete line of steam and power-driven, duplex type vacuum pumps.

In general the design of these machines follows that of the

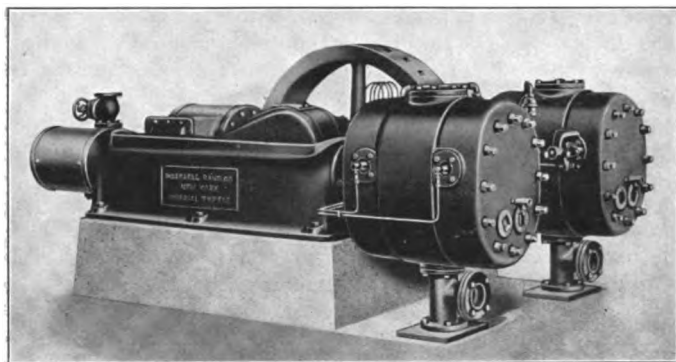

Steam-Driven Duplex Vacuum Pump

Imperial air compressors manufactured by the same company. The intake valves are of the Corliss type, so placed in the cylinder head that the clearance is exceptionally low. This is a desirable feature in that the air trapped in the clearance spaces at discharge pressure will not reach such a volume, upon being expanded to intake pressure, as to greatly limit the pressure reduction which may be obtained. The action of the valve is quick and positive and is independent of the cylinder and intake pressures; the pressures within and without the cylinder are as nearly equal as possible. The intake ports are large and

direct, which together with the water jacketing of the valves tends to cool the intake gases.

The discharge valves, which are of the direct lift poppet type, are placed in the bottom of the cylinder heads so that any entrained moisture or water is immediately discharged, a feature that tends to insure safety in handling moist or even saturated vapor. Clearance at the point of discharge has been reduced by making the valve partially fill the port in the cylinder head. The discharge passages are also water jacketed. Both cylinder and heads are completely water jacketed, which is an essential feature in the design of vacuum pumps, as the high ratios of compression tend to create high discharge pressures unless the heat is removed in the cylinder. Tie bolts pass from head to head and hold cylinder and heads tightly assembled.

The running gear, including the main frame with its enclosed reciprocating parts, the crank shaft, connecting rod, crosshead,

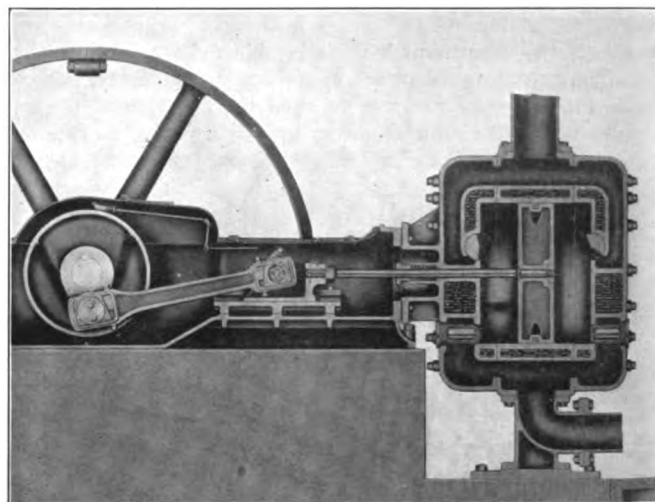

Section Through Cylinder of Vacuum Pump

valve gear and wheel on both belt and steam-driven machines are of the same design as used on Imperial air compressors. Lubrication is obtained by the bath system, providing automatic flood lubrication. By the removal of covers from the casing the enclosed parts are readily accessible. The Imperial vacuum pump occupies less floor space than machines of similar capacity of the straight line type, due to its duplex construction and to the fact that its speed of operation is higher. It is possible, should requirements fall temporarily below that for which the equipment was originally installed, to remove one connecting rod and discontinue the operation of one-half of the machine, while the other half operates at its rated speed and hence its utmost efficiency, displacing, however, one-half the vapor the entire machine is capable of handling.

The machines are built in capacities from 798 to 7,048 cu. ft. per minute both for atmospheric and low pressure (5 lb.) discharge. It is claimed that they may be operated practically without attention and the maintenance of a vacuum within 1/2 in. of the barometric vacuum is guaranteed.

IRON INDUSTRY IN BELGIUM.—Recent reports state that in the Liege district of Belgium only 6,800 men are employed in the iron industry out of a total of 14,700 in normal times. The Cockerill works are employing 5,200 in the blast furnaces, rolling mills and forge departments. Two small furnaces are in blast, yielding about 100 tons daily. In the Charleroi district the Providence works have one furnace in blast with a daily output of 150 tons. A revival of the steel industry is said to be only possible if Luxembourg ores can be obtained by a reduction of the high freight rates. Available raw materials are becoming scarcer and the industry may be brought to a total standstill.—*The Iron Age.*

HIGH SPEED RADIAL DRILL

A new design of radial drilling and tapping machine has been developed by the Fosdick Machine Tool Company, Cincinnati, which is known as the High Speed Manufacturing Radial, and is built in two sizes having 2-ft. and 2-ft. 6 in. arms, respectively. It is especially intended to meet the demand for a high-speed, durable machine, capable of handling a great variety of work in shops where unskilled labor is employed.

In general appearance these machines show a marked resemblance to the heavy duty radials built by the same company, and, in fact, the oil channel base and table, the double tubular column and the speed box are identical in both designs. The material used for the various parts has been carefully selected. The bushings are of special phosphor bronze, and gears under severe duty are of steel forgings, hardened where necessary. Where the speed is high or the duty light, cast iron or bronze of extra wide face and course pitch, are used. The spindle and principal driving shafts are of hammered steel, and the column, spindle and arm elevating thrusts are taken on ball bearings. The column and shafting are all finished by grinding.

These machines have a range of forty-eight rates of drilling, correct for 3/16-in. carbon to 2½-in. high speed drills in either iron or steel, and for boring up to five inches, all with but one speed at the pulley. A mental plate on the arm girdle, for high speed drilling, corresponds to the indexes on the head and on the

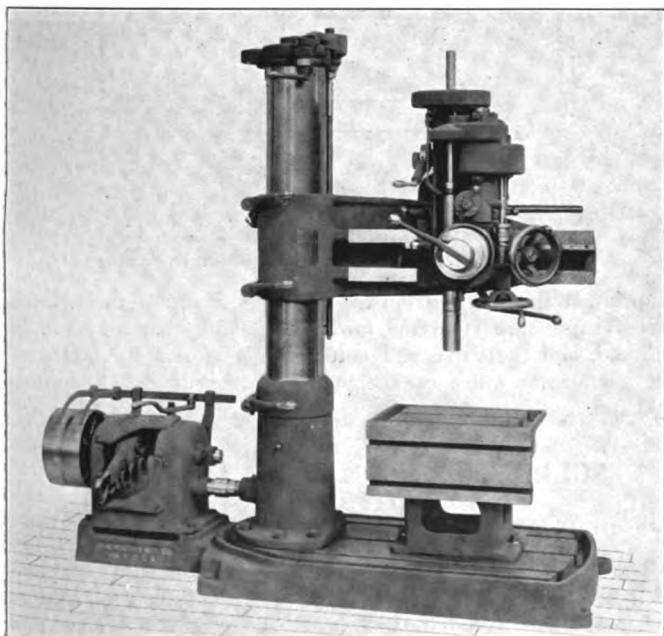

High-Speed Radial Drilling and Tapping Machine

speed box. Thorough tests have been made at the works with high speed drills up to 2½ in. in diameter in machinery steel and in cast iron, showing the pulling power to be far in excess of what will ever be required. For example, a 1-in. high speed drill was driven through a very hard cast iron slab two inches thick, in 7 4/5 seconds, or at a rate of 15.4 in. per minute; the speed being 550 r. p. m., and the feed .028 in. per revolution. The 2½-in. drill was successfully driven through 1½ in. of machinery steel at various rates, ranging from 137 r. p. m. with .007 in. feed, to 49 r. p. m. with a feed of 0.28 in. per revolution.

The 2-ft. machine will drill to the center of a 48-in. circle at the base, which has a working surface of 26 in. by 31 in. The 2 ft. 6 in. machine drills to the center of a 60-in. circle, and has a base working surface of 28 in. by 36 in. Other principal dimensions common to both machines are: base to spindle, 51 in.; spindle traverse, 12 in.; least diameter of spindle, 1 9/16 in.; spindle bore, Morse Taper No. 4. Tilting, swinging or round

tables of the builder's standard types can be supplied. The net weight of the machines are 2,900 lb. and 3,200 lb., respectively.

As on heavy duty radials, the interchangeable drive has been adopted. The cone driven machine may be changed to speed box drive, or vice versa, or a constant or variable speed motor may be added at any time after purchase without the necessity of a special base, special speed box or special shafts or gears in the machine.

SMOKEBOX BLOWER FITTING

The illustration shows a locomotive blower fitting which is provided with a flange for direct attachment to the side of the smokebox. It is provided with three pipe connections,

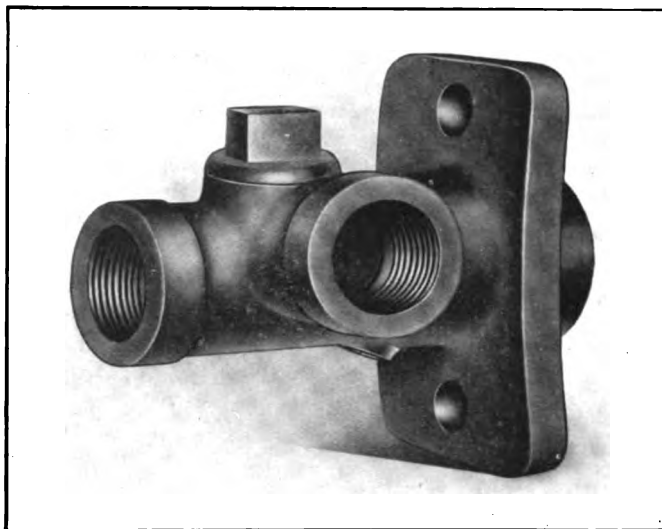

Smokebox Blower Fitting

the inside connection leading to the blower nozzle, the right angle connection to the blower pipe in the cab, and the other to the roundhouse blower connection. A check valve, readily accessible through the cap shown in the illustration, automatically closes the roundhouse blower connection when the engine blower is in operation. It raises when the roundhouse blower is in operation and allows steam to pass into the smokebox. All passages are made for 1¼ in. pipe. It is manufactured by the Barco Brass & Joint Company, Chicago.

BORING TOOL HOLDERS

The boring tools illustrated herewith were recently placed on the market by the Rigid Tool Holder Company, Baltimore, Md. The tools consist mainly of a special lathe boring bar, in ten sizes, four types of holders therefor to meet various conditions, a special cutting off tool and internal and external thread tools.

The boring bar and two styles of holders are shown in the illustrations. The bar is made in diameters ranging from ½ in. to 2¼ in., and is fitted with a special cutter clamp which conforms to the normal exterior surface of the bar. This is held in place by means of two screws, the one nearest the end being threaded into the body of the bar and acting in tension, while the other is threaded into the clamp and acts as a set screw against the bar body. It has a leverage of 5½ to 1 against the cutter, which it securely clamps in position.

The tool post holder is a simple one-piece holder which has an angular opening between the shank and the barrel through which the bar passes. This enables the shank to be passed through the tool post until its front edge is supported by the

tool post wedge. The angle of the barrel also brings the cutter on a line directly in front of the wedge. The barrel is fitted with a bearing for the bar at each end, the latter being rigidly secured by two tool steel set screws.

The adjustable boring tool is designed for general application and fits practically any lathe from 12-in. swing up. It replaces the ordinary tool post, and its broad base and heavy

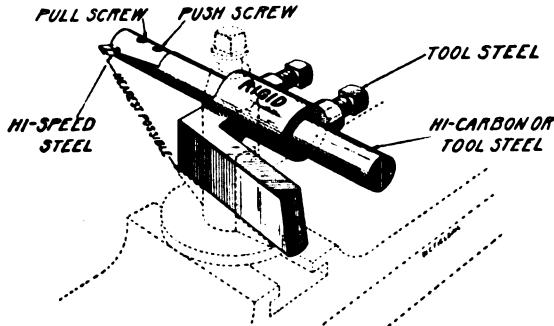

The Rigid Tool Post Holder

construction is intended to give it exceptional rigidity. The swiveling elevating yoke may be clamped in any desired position between elevations varying approximately from 1 7/16 in. to 2 1/8 in. Large key-ways cut with this tool have parallel sides where small cutters are used, because the tool may be elevated instead of revolving the work for succeeding cuts.

A double reversible holder is made which is a single piece of steel and very rigid. It is provided with two parallel holes or barrels, in either of which the tool may be clamped by set screws.

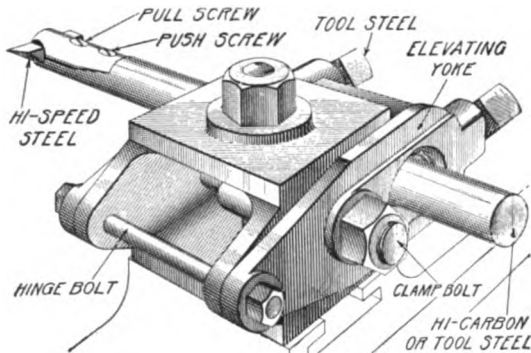

Double Reversible Tool Holder

These holes are so offset from the horizontal center line of the piece that by reversing it end for end and vertically a selection of four heights is available varying by eighths of an inch. The single reversible holder is a special tool, and reverses vertically only, giving but two heights of the tool.

AUTOMATIC NON-RETURN VALVE

The Golden-Anderson Valve Specialty Company, Pittsburgh, Pa., has placed on the market an automatic double-cushioned non-return valve for steam boilers. It is placed in the connection from each boiler to the main steam line to prevent back flow from the steam line when the pressure in the boiler is lower than that of the steam line. This automatic feature will protect the boiler in case of accident, such as the bursting of a tube, and will act as a safety stop to prevent steam from being turned into cold boilers. As the pressure in the boiler accumulates the main valve *B* will be raised and steam will be permitted to flow into the header. The chamber *F* serves as a cushioning chamber for the valve in its upward movement, and the chambers *D* and *E* cushion the valve in closing, these chambers being open to the steam pressure and connected

through the valve by the passage *C*. By this construction hammering or chattering of the valve is eliminated. There is only one moving part to the entire valve, and that is the piston, *B*, which, as shown, is substantially guided in the body of the valve. The pipe at the left of the valve, extending out from the valve body, connects with a globe valve at some convenient position for testing the automatic service feature of the piston *B*. By

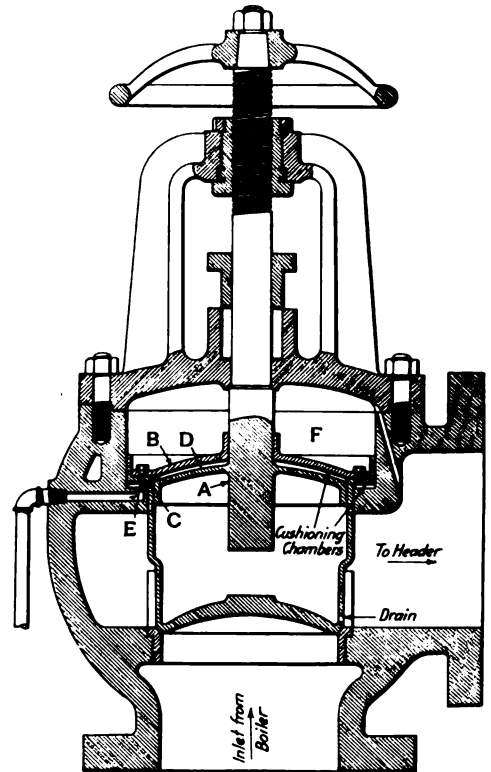

Golden-Anderson Automatic Non-Return Valve

allowing steam to flow from the chambers *E* and *D* through this pipe the pressure from the lower cushioning chambers will be relieved, and the valve will automatically close. By means of the spindle the valve can be maintained in its closed position by hand.

SULLIVAN PISTON AND VALVE STEM PACKING

The process of applying packing to the piston and valve rods of locomotives does not present very much difficulty. The packing must be of a material that will not melt at the temperature of the steam, and will still be soft enough not to injure the rod. If this packing is bored out to an exact fit on the rod it will be tight. As the engine continues in service, however, the ring will become worn. A packing is thus desirable that will permit of continued wear until the packing rings are worn out. A packing ring that is cut square across the ring is believed to be preferable to that which is cut tangentially, as in the latter case the short ends are liable to become broken, thus permitting blows. Where the square cut ring is used there must be a clearance between the segments of each ring, and in order to make the packing tight two rings must be used, having the parting of their segments staggered. These rings will wear until the ends of the segments come in contact, when the ends should be filed to give the proper clearance. Another feature that is desirable is to have the packing rings maintain a constant bearing on the rods so that the ring will wear evenly throughout its bearing surface.

To meet these conditions the Jerome-Edwards Metallic Packing Company, Chicago, has placed on the market the improved

Sullivan piston and valve stem packing. In the illustration, *A* is the piston rod; *B*, the swab cup; *C*, the gland; *E*, the vibrating cup; *F*, the brass ring; *H*, a combined spring case and follower; *I*, the spring; *J*, the cone packing ring with a double bevel; *K*, the second packing ring; and *X*, the stuffing box. From this construction it will be seen that the spring *I* presses the packing ring *K* against the packing ring *J* (with the double bevel),

is secured a swivel fork attachment. There are three rollers attached to the swivel plate, two of which are at right angles to the pole and are tapered. The third roller is located between the base of the other two and has its axis at right angles to them. It is intended to reduce the friction at the edge of the belt so that there is no possibility of the belt catching or sticking. The tapered rollers, between which the belt is placed, effect a tendency at all times for the belt to slide onto the pulley and away from the shifter. This is said to practically overcome the possibility of accident.

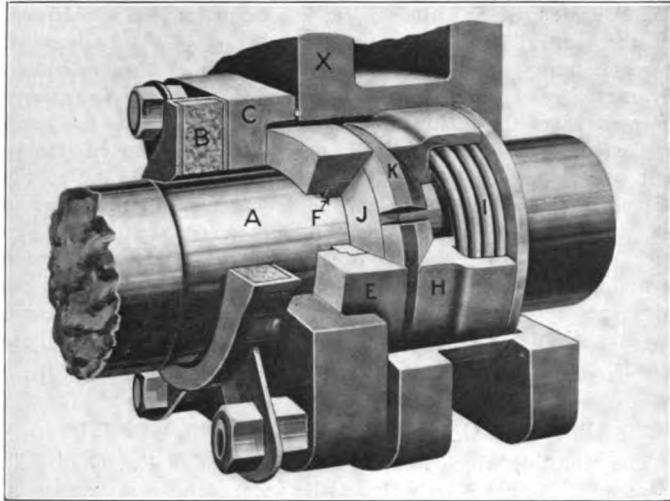

Construction of Sullivan Packing

forcing it onto the rod and at the same time against the vibrating cup *E*, which, being beveled, also forces it against the rod. With this construction steam leaks between the rod and the packing ring, or between the outside of the packing ring and the inside of the vibrating cup, are eliminated; in addition, the double bevel on the cone ring, *J*, tends to keep it central and the wear will thus be uniform.

SAFETY BELT STICK

A belt shifter, which is not only designed to save time, but to provide an absolutely safe means of shifting belts or throwing them on and off pulleys in motion, has been designed by

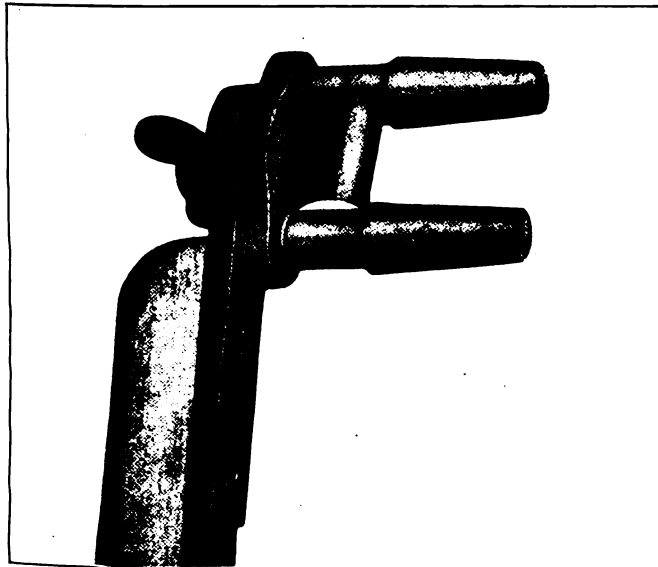

Swivel Roller Belt Shifter

the Ready Tool Company, Bridgeport, Conn. The device consists of a piece which is bolted to the regulation pole, to which

WORM WHEEL CUTTING MACHINE

The accompanying photograph shows a new worm-wheel cutting or generating machine, which has recently been developed by the Newton Machine Tool Works, Inc., Philadelphia, Pa., the cutting being done by either fly cutters or a taper hob. The cutter or hob has the form of a tap and is set so that the distance between its axis and the axis of the wheel is the same as that between the worm and wheel, and its angle to the plane of wheel is the same as that at which the worm actually runs. These measurements remain unchanged during the entire process of cutting.

Contrary to the practice generally followed, by which the teeth of the wheel are gradually cut deeper by feeding the cut-

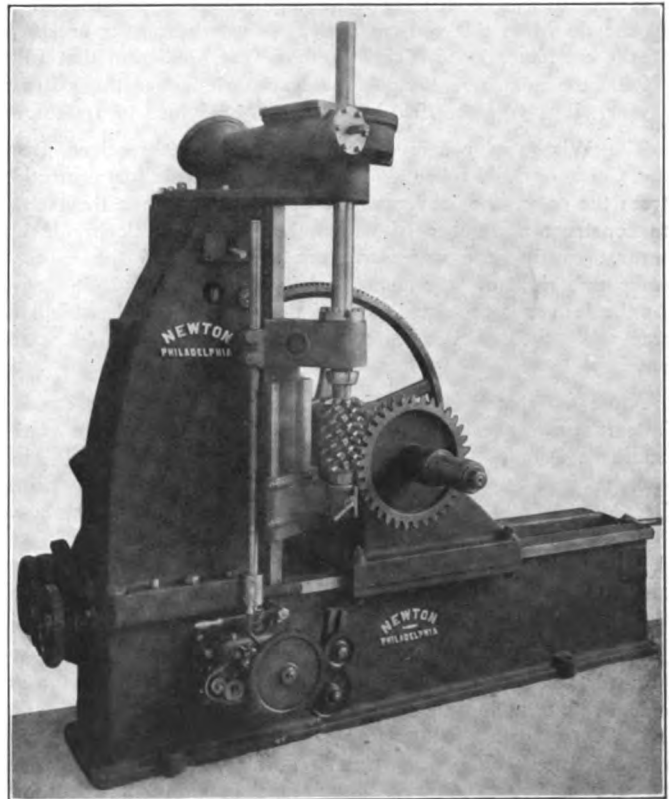

Tangential Feed Worm Wheel Cutting Machine

ter radially toward the wheel center, the cutter in this process is fed along its axis at a tangent to the circumference of the wheel, thus first cutting with the tapered end into the solid metal. The teeth of the wheel become gradually deeper as the increasing diameter of the cutter is fed into the work, the teeth being finished by the full end of the cutter as it passes through the work.

A large worm wheel having an outside diameter of 47½ in., a face 5½ in. wide and 92 teeth, triple lead and 2 diametral pitch, was put on this machine in 10 hours.

NEWS DEPARTMENT

Fire destroyed the coach and paint shop, a storeroom and several passenger coaches and freight cars of the Texas & Pacific at Marshall, Texas, on October 1.

The ocean-going ferry, Henry M. Flagler, carrying freight cars between Key West and Havana, is being worked to its full capacity, and officers of the Florida East Coast say that the facilities will soon be increased by the addition of another boat. It is proposed to build a vessel with a capacity of 38 cars. The Henry M. Flagler carries 28 cars.

One of the 50 electric locomotives being delivered by the General Electric Company to the Chicago, Milwaukee & St. Paul for use on the line between Harlowton, Mont., and Avery, Idaho, was placed on exhibition this week at the Union Station in Chicago. These locomotives are to be put in service sometime in November. The locomotives weigh 260 tons each, have 8 pairs of driving wheels, are 112 ft. long over all and are designed for operation with direct current at 3,000 volts.

On Saturday, November 6, the Business Men's Association of Deposit, N. Y., will celebrate, with a parade and speeches, the eightieth anniversary of the Erie. On November 7, 1835, the first ground was broken for the Erie Railroad at Deposit, N. Y. At the time that this construction work was begun the president of the company, James G. King, made the prediction that fully 200,000 tons of freight would be transported over the railroad a year. Last year the Erie handled 42,874,315 tons of freight.

The Wisconsin conservation commission has received from the Chicago, Milwaukee & St. Paul an appeal for protection from the colony of beaver which have taken it upon themselves to construct a number of dams along Bear Creek in Oneida county, causing the water to back up and flood the railroad company's right of way in the vicinity of Merrill and Goodnow. As the beaver is protected by law, the railroad could not kill or trap the animals, even though their dams are causing wash-outs.

A press despatch October 3 from Imlay, Nev., reports damage by earthquake shocks for a hundred miles along the line of the Southern Pacific. Several water tanks toppled from their high supports and one at Lovelock crushed the end of a dwelling. People fled from their homes in night clothing at many places. Slow orders were issued to all trains when the third shock was felt at 11 o'clock on the night of the third. At Golconda, Nev., a piece of track sank five inches. All the towns named are between Sparks and Battle Mountain.

John P. Dohoney, investigator of accidents, has made his report to the Pennsylvania Public Service Commission on the accident in a tunnel on the Philadelphia & Reading, at Phoenixville, Pa., September 28, when nine workmen were killed and nine others injured. The work train, on which these men were employed, had just entered the tunnel, on the southbound track, and had stopped; when a southbound passenger train, running on the northbound track, and moving at about ten miles an hour, ran into the men, who were walking along the track and, as it appears, struck more than one-third of the gang of fifty. The principal explanation given is that the conductor of the work train had given proper notice or instructions to the foreman and the workmen before entering the tunnel; but the state inspector says that this notice, if heard at all, was misunderstood, and that a written order should have been given to the foreman, explaining the proposed movement. The workmen were all foreigners, mostly Italian. They had been engaged for two weeks in the work of widening the tunnel.

BROWNELL'S AUTOMATIC STOP

A mechanical-trip automatic train stop, invented by George W. Brownell, of St. Albans, Vt., has been tried on a sidetrack of the Central Vermont Railway at that place. Mr. Brownell places a ramp on the ties between the rails of the track and, by means of a sliding tripper, suspended from the locomotive frame, causes the lifting of a valve on the engine as the ramp is passed, applying the air-brakes. The ramp is moved into or out of position by a dog, turned by a shaft connected to the visual signal. To prevent trouble from freezing, the ramp is supported in a trough, which, in winter, contains salt. The air apparatus, on the locomotive, moves a piston in a double cylinder, so arranged as to exhaust, at first, only a part of the air necessary to make a service application, further reduction, as may be demanded, being provided for by suitable adjustments.

PANAMA CANAL BLOCKED FOR A MONTH

The landslide which blocked the Panama Canal at Gold Hill, September 20, has been followed by others, and it is announced this week that vessels cannot pass through before November 1.

At least 1,000,000 yards of earth must be removed. On Tuesday the steamer Finland from New York was waiting, with 300 passengers aboard, and another vessel of the same line was waiting on the Pacific side. Both these vessels have also large cargoes of freight. The quantity of freight in vessels waiting to pass through the canal is so great that it could not be transported over the Panama Railroad in less than a month. Colonel Chester Harding, engineer in charge of the canal, has recommended that tolls already paid by waiting vessels be refunded.

According to the Canal Record, on October 5, there were 83 vessels tied up in the canal. Of these 45 were on the Atlantic side with an aggregate of approximately 167,000 tons of cargo, and 38 were on the Pacific side with approximately 189,000 tons of cargo. A number of boats which had intended passing through the canal are taking their cargoes around via the Straights of Magellan.

TEXAS RAILWAYS URGE LAW AGAINST TRESPASSING

The Texas railways are conducting a campaign in the interest of adequate laws to prohibit trespassing. As a part of this campaign the Central Safety First Committee of the International & Great Northern has issued a bulletin calling attention to the large number of trespassers killed on the railways every year, and urging school teachers, employers of labor, ministers, parents and others to do everything in their power to educate those within their sphere of influence regarding the evils of trespassing. The circular states that during the last 13 years the International & Great Northern has carried on its trains nearly 20,000,000 passengers without killing or even maiming a single passenger in train accidents, "which proves that the International & Great Northern is a very safe road for passengers;" but that during the same period its trains killed or seriously injured over 500 people, while trespassing on its yards and along the right of way, "which proves that the I. & G. N., like other railways, is a very unsafe place to walk upon."

Vice-president W. A. Webb, of the Missouri, Kansas & Texas, has issued a similar circular to all employees of the operating department, in which he says that more lives would be saved by enforcing laws against trespassing than by providing steel cars, installing block signals and abolishing grade crossings.

CAR AND LOCOMOTIVE ORDERS IN OCTOBER

During the month of October orders for locomotives, freight cars and passenger cars were reported as follows:

	Locomotives	Freight Cars	Passenger Cars
Domestic	280	21,339	16
Foreign
Total	280	21,339	16

Among the more important orders for locomotives were the following: Pittsburgh & Lake Erie, 10 Mikado type locomotives, American Locomotive Company; Central of Georgia, 8 Mikado and 4 Pacific type locomotives, Lima Locomotive Corporation; Atchison, Topeka & Santa Fe, 30 Mikado type locomotives, Baldwin Locomotive Works; Philadelphia & Reading, 30 Mikado type locomotives, Baldwin Locomotive Works; Cincinnati, Indianapolis & Western, 42 locomotives, Lima Locomotive Corporation; Illinois Central, 47 Mikado type locomotives, Lima Locomotive Corporation, and 3 Santa Fe type locomotives, American Locomotive Company, and the Pennsylvania Railroad, 75 Mikado type locomotives, Baldwin Locomotive Works.

The largest order for freight cars reported during the month was, of course, that placed by the New York Central. As nearly as can be ascertained the order has been divided as follows: Haskell & Barker Car Company, 2,000 box cars; Pullman Company, 1,000 automobile cars; American Car & Foundry Company, 1,500 box cars, and the Standard Steel Car Company, 4,500 gondola cars, a total of 9,000 cars, these being in addition to orders placed in September and previously reported. Among other large orders were: Wheeling & Lake Erie, 750 gondola cars, Standard Steel Car Company, and 200 automobile cars, Western Steel Car & Foundry Company; Illinois Central, 1,000 refrigerator cars, American Car & Foundry Company; Central of Georgia, 500 freight cars, American Car & Foundry Company, and 500 box cars, Pullman Company; Norfolk & Western, 1,000 90-ton gondola cars, company shops; Chesapeake & Ohio, 1,000 gondola cars, Standard Steel Car Company; Western Maryland, 2,000 hopper cars, Pullman Company, and Philadelphia & Reading, 1,000 box cars, American Car & Foundry Company; 500 gondola cars, Standard Steel Car Company, and 1,000 hopper cars, Pressed Steel Car Company.

Of the 16 passenger cars noted in the table 14 were ordered by the Boston & Maine of the Pullman Company and the Laconia Car Company.

MEETINGS AND CONVENTIONS

The Central Railway Club.—At the next meeting of the Central Railway Club, which will be held in Buffalo on the evening of November 12, 1915, arrangements have been made for an informal complimentary dinner at Hotel Statler. This will be served at six o'clock, and will be followed by the regular meeting at eight o'clock. The paper of the evening will be on "Rubber: From Raw to Finished Product," and will be illustrated with moving pictures. Ladies are invited to both occasions.

Chilled Car Wheel Manufacturers.—At the annual meeting of the Association of Manufacturers of Chilled Car Wheels, held in New York on October 12, officers were re-elected as follows: President and treasurer, George W. Lyndon; vice-presidents, E. F. Carry and J. A. Kilpatrick; secretary, George F. Griffin; con-

sulting engineer, F. K. Vial. The board of directors consists of E. F. Carry, J. A. Kilpatrick, W. S. Atwood, Chas. A. Lindstrom, F. K. Vial, A. G. Wellington, W. C. Arthurs, J. D. Rhodes, F. B. Cooley, A. J. Miller and Wm. F. Cutler.

June Mechanical Conventions.—A joint meeting of the executive committees of the Master Car Builders' Association, the American Railway Master Mechanics' Association and the Railway Supply Manufacturers' Association will be held at the Hotel Statler, Cleveland, Ohio, Monday, November 15, at 10 a. m. The object of the meeting will be to decide upon the dates for the June conventions, as well as the place of the meetings, and also to discuss other details of the joint work of these three associations. It is planned also to hold separate meetings of the executive committees of each one of the associations after the joint meeting. The meeting is being held at Cleveland because of the illness of President MacBain, of the Master Car Builders' Association, who expects, however, to be sufficiently recovered by November 15 to participate.

American Society of Mechanical Engineers.—The annual meeting of the American Society of Mechanical Engineers will be held at the Engineering Societies' Building, 29 West Thirty-ninth Street, New York City, on December 8, 9, and 10, 1915. The railroad session will be held on the afternoon of Wednesday, December 8, and considerable effort has been put forth by the sub-committee on railroads to provide a program of general interest. Papers will be presented as follows: Operation of Parallel and Radial Axles of a Locomotive by a Single Set of Cylinders, by Anatole Mallet, and Four-Wheel Trucks for Passenger Cars, by Roy V. Wright, Managing Editor Railway Age Gazette, which is published elsewhere in this issue. It is also expected that a paper will be read on the six-wheel truck for passenger cars.

The following list gives names of secretaries, dates of next or regular meetings and places of meeting of mechanical associations:

- AIR BRAKE ASSOCIATION.—F. M. Nellis, 53 State St., Boston, Mass.
- AMERICAN RAILROAD MASTER TINNERS, COPPERSMITHS AND PIPEFITTER' ASSOCIATION.—W. E. Jones, C. & N. W., 3814 Fulton St., Chicago.
- AMERICAN RAILWAY MASTER MECHANICS' ASSOCIATION.—J. W. Taylor, Karpen Building, Chicago.
- AMERICAN RAILWAY TOOL FOREMEN'S ASSOCIATION.—Owen D. Kinsey, Illinois Central, Chicago.
- AMERICAN SOCIETY FOR TESTING MATERIALS.—Prof. E. Marburg, University of Pennsylvania, Philadelphia, Pa.
- AMERICAN SOCIETY OF MECHANICAL ENGINEERS.—Calvin W. Rice, 29 W. Thirty-ninth st., New York. Annual meeting, December 7-10, 1915, New York.
- ASSOCIATION OF RAILWAY ELECTRICAL ENGINEERS.—Joseph A. Andreucetti, C. & N. W., Room 411, C. & N. W. Station, Chicago.
- CAR FOREMEN'S ASSOCIATION OF CHICAGO.—Aaron Kline, 841 North Fiftieth Court, Chicago. Second Monday in month, except July and August, Lytton Building, Chicago.
- CHIEF INTERCHANGE CAR INSPECTORS' AND CAR FOREMAN'S ASSOCIATION.—W. R. McMunn, New York Central, Albany, N. Y.
- INTERNATIONAL RAILWAY FUEL ASSOCIATION.—C. G. Hall, 922 McCormick Building, Chicago.
- INTERNATIONAL RAILWAY GENERAL FOREMEN'S ASSOCIATION.—William Hall, 1126 W. Broadway, Winona, Minn.
- INTERNATIONAL RAILROAD MASTER BLACKSMITHS' ASSOCIATION.—A. L. Woodworth, Lima, Ohio.
- MASTER BOILER MAKERS' ASSOCIATION.—Henry D. Vought, 95 Liberty St., New York.
- MASTER CAR BUILDERS' ASSOCIATION.—J. W. Taylor, Karpen Building, Chicago.
- MASTER AND LOCOMOTIVE PAINTERS' ASSOCIATION OF U. S. AND CANADA.—A. P. Dane, B. & M., Reading, Mass.
- NIAGARA FRONTIER CAR MEN'S ASSOCIATION.—E. Frankenberger, 623 Brisbane Building, Buffalo, N. Y. Meetings monthly.
- RAILWAY STOREKEEPERS' ASSOCIATION.—J. P. Murphy, Box C, Collinwood, Ohio.
- TRAVELING ENGINEERS' ASSOCIATION.—W. O. Thompson, N. Y. C. R. R., East Buffalo, N. Y.

RAILROAD CLUB MEETINGS

Club	Next Meeting	Title of Paper	Author	Secretary	Address
Canadian	Nov. 9	Rubber as Related to the War.....	A. D. Thornton..	James Powell.....	St. Lambert, Que.
Central	Nov. 12	Rubber: From Raw to Finished Product.	Harry D. Vought.	95 Liberty street, New York.
New England....	Nov. 9	The Fuel Department—A Failure?.....	L. G. Plant.....	Wm. Cade, Jr.....	683 Atlantic avenue, Boston, Mass.
New York.....	Nov. 19	The Railroads and National Defense....	Geo. D. Snyder....	Harry D. Vought.	95 Liberty street, New York.
Pittsburgh.....	Nov. 26	Workmen's Compensation	W. S. Diggs.....	J. B. Anderson....	207 Penn Station, Pittsburgh, Pa.
Richmond.....	Nov. 8	Election of Officers.....	F. O. Robinson....	C. & O. Ry., Richmond, Va.
St. Louis.....	Nov. 12	Pleasant Valleys and Rocky Mountains.	H. R. Leffingwell..	B. W. Frauenthal.	Union Station, St. Louis, Mo.
South'n & S'w'rn	Nov. 18	Locomotive Inspection	Frank McManamy.	A. J. Merrill.....	Box 1205, Atlanta, Ga.
Western	Jos. W. Taylor....	1112 Karpen Bldg., Chicago, Ill.
Western Canada..	Louis Kon.....	Box 1707, Winnipeg, Man.

PERSONALS

GENERAL

C. E. BROOKS, acting superintendent of motive power of the Grand Trunk Pacific, has been appointed superintendent of motive power, with office at Transcona, Man. He will also assume the duties of master car builder.

A. H. EAGER, superintendent of shops of the Canadian Northern at Winnipeg, Man., has been appointed assistant superintendent of rolling stock with headquarters at Winnipeg.

CLYDE C. ELMES has been appointed assistant superintendent of motive power and rolling equipment of the Philadelphia & Reading with headquarters at Reading, Pa. Mr. Elmes began



C. C. Elmes

railway work in 1903, at the Olean, N. Y., shops of the Pennsylvania Railroad, and after learning the machinists' trade he attended Purdue University. He subsequently returned to the Pennsylvania Railroad at Olean, as gang foreman, and later was promoted to roundhouse foreman. He then served as superintendent at Auburn, N. Y., of the New York, Auburn & Lansing, now the Central New York Southern, leaving that company to go to the Kansas City Southern as superintendent of construction of new shops

at Shreveport, La., and on the completion of that work was transferred to Pittsburgh, Kan., as roundhouse foreman. He was subsequently promoted to chief inspector of new locomotives being built for that road. He was then consecutively general foreman at Ennis, Texas, of the Houston & Texas Central, acting master mechanic of the general shops of the Southern Pacific at Houston and master mechanic of the same shops with the duties of master car builder until his appointment as assistant division superintendent of the Texas & New Orleans. He then went to the Philadelphia & Reading and served consecutively as motive power inspector, road foreman of engines and as assistant engineer of motive power until his recent appointment as assistant superintendent of motive power and rolling equipment of the same road, as above noted.

A. L. GRABURN, mechanical engineer of the Canadian Northern at Toronto, Ont., has been appointed assistant superintendent of rolling stock of the Eastern lines, with office at Toronto, Ont.

W. L. HAZZARD has been appointed supervisor of piece work, motive power department of the New York Central, with office at Grand Central Terminal, New York.

J. A. MITCHELL has been appointed general foreman of the National Transcontinental, in charge of the motive power department at Transcona, Man.

IRWIN A. SEIDERS has been appointed superintendent of motive power and rolling equipment of the Philadelphia & Reading, with headquarters at Reading, Pa. Mr. Seiders was born on October 23, 1864, at Tamaqua, Pa., and was educated in the public schools. He began railway work on January 18, 1882, as a laborer on the Philadelphia & Reading, and the same year

became machinist helper. He later served as station hand and then as brakeman until September, 1888, when he was appointed locomotive fireman, and two years later became an engineman. In April, 1907, he was promoted to road foreman of engines, remaining in that position until December, 1914, when he was appointed fuel inspector, and now becomes superintendent of motive power and rolling equipment on the same road, as above noted. Mr. Seiders' entire railway service has been with the Philadelphia & Reading.

GORDON SPROULE has been appointed acting engineer of tests of the Canadian Pacific at Montreal, Que., succeeding E. B. Tilt, resigned.

SAMUEL G. THOMSON, superintendent of motive power and rolling equipment of the Philadelphia & Reading at Reading, Pa., has resigned.

MASTER MECHANICS AND ROAD FOREMEN OF ENGINES

J. E. GOULD has been appointed master mechanic of the Charlotte Harbor & Northern with office at Arcadia, Fla., succeeding W. H. McAmis, resigned to accept service elsewhere.

R. M. KINCAID, valuation engineer of maintenance of equipment of the Chicago & Eastern Illinois, has been appointed master mechanic of the Illinois and St. Louis divisions, with office at Villa Grove, Ill., succeeding F. Studer, resigned.

W. C. MOORE, master mechanic of the Ottawa division of the Canadian Northern at Trenton, Ont., has been appointed master mechanic of the Toronto district, with headquarters at Trenton, Ont.

CAR DEPARTMENT

H. W. ANDREW, coach yard foreman of the Canadian Northern at Winnipeg, Man., has been appointed general car foreman at that point, succeeding A. McCowan, promoted.

E. ELEY, division car foreman of the Canadian Pacific at North Bay, Ont., has been appointed master car builder, eastern lines, with office at Montreal, Que., succeeding F. B. Zercher.

E. HACKING, heretofore car foreman of the Grand Trunk Pacific at Prince George, B. C., has been appointed general car foreman, to look after the Grand Trunk Pacific car equipment turned out of the Transcona shops, now operated by the National Transcontinental.

J. L. HODGSON, formerly master car builder, Grand Trunk Pacific, has been appointed general car foreman, National Transcontinental, at Transcona, Man., and has charge of the car department at divisional points, Transcona to Fort William inclusive.

J. E. JOHNSTON, night coach foreman of the Canadian Northern at Winnipeg, Man., has been appointed coach yard foreman at that point, succeeding H. W. Andrew, promoted.

A. McCOWAN, general car foreman of the Canadian Northern at Winnipeg, Man., has been appointed supervisor of car works at the same place.

C. A. MUNRO has been appointed car foreman of the Grand Trunk Pacific at Prince George, B. C., succeeding E. Hacking, promoted.

EDWARD J. THILL has been appointed supervisor of piece work, rolling stock department of the New York Central, with office at Grand Central Terminal, New York City.

SHOP AND ENGINE HOUSE

H. DARBY has been appointed acting locomotive foreman of the Grand Trunk Pacific at Biggar, Sask., succeeding A. McTavish, promoted.

A. T. HANNAH, formerly assistant foreman of the Canadian Northern at Saskatoon, Sask., has been appointed locomotive foreman at Humboldt, Sask., succeeding W. B. Steeves, transferred to Saskatoon, Sask.

C. R. HENING, roundhouse foreman of the Michigan Central at Kensington, Ill., has been appointed general foreman of the machine shop at Michigan City, Ind.

L. B. JONES has been appointed general foreman in charge of the mechanical department of the Macon, Dublin & Savannah at Macon, Ga.

FRED A. RAUBER has been appointed night roundhouse foreman of the Atchison, Topeka & Santa Fe at Dodge City, Kan.

A. MCTAVISH, formerly locomotive foreman of the Grand Trunk Pacific at Biggar, Sask., has been appointed locomotive inspector to look after Grand Trunk Pacific motive power equipment turned out of the Transcona shops by the National Transcontinental.

PURCHASING AND STOREKEEPING

FRANK P. DUGAN has been appointed division storekeeper of the Illinois Central at Vicksburg, Miss., succeeding Eugene D. Meissonnier, resigned.

C. E. LEPARD, heretofore employed in the office of the locomotive foreman of the Canadian Northern at Regina, Sask., has been appointed division storekeeper at that city, succeeding J. Butterfield, enlisted for active military service.

WILLIAM S. MOREHEAD has been appointed division storekeeper of the Illinois Central at McComb, Miss., succeeding Frank P. Dugan.

W. D. STEWART, heretofore foreman of the erecting shop, Intercolonial Railway, Moncton, N. B., has been appointed assistant to the general storekeeper of the Canadian Government Railways, with office for the present at Transcona, Man.

WILLIAM D. STOKES has been appointed assistant general storekeeper of the Illinois Central, with headquarters at Memphis, Tenn., succeeding William S. Morehead, transferred.

NEW SHOPS

THE LAKE ERIE & WESTERN.—This company is constructing a concrete machine shop, 40 ft. by 120 ft., at Tipton, Ind., to replace the building destroyed by fire some time ago.

THE ILLINOIS CENTRAL.—This company will build a steel structure, 176 ft. by 1,200 ft., equipped for repairing wooden cars at Nonconah, Tenn. The contract for the construction work has not yet been let, but about one thousand tons of steel have been ordered from the American Bridge Company.

THE INTERNATIONAL & GREAT NORTHERN.—This company has purchased 108 acres of land, five miles out of San Antonio, Tex., as a site for shops, yards and roundhouses. It is stated that approximately \$500,000 will be expended. The plans for the buildings have been drawn and work will be started soon. O. H. Crittenden, chief engineer, Houston, Tex.

THE SEABOARD AIR LINE.—This company has given a contract to the Christian Construction Company, Durham, N. C., to build additional shop facilities at Portsmouth, Va. The work will include a machine and erecting shop, blacksmith shop, flue shop, engine carpenter and paint shop, also a sub-station. The work will be pushed to completion, and it is expected that it will be finished early in 1916. There is considerable steel work involved in the construction of the main buildings, and hy-rib walls or similar material will be used in the machine and erecting shop.

SUPPLY TRADE NOTES

Stanley H. Smith has been appointed district sales manager of the Pennsylvania and Maryland Steel Companies at Chicago, to succeed Robert E. Belknap, transferred to New York City.



S. H. Smith

Mr. Smith was born at Toronto, Ont., on August 4, 1885. He entered the service of the Pennsylvania Steel Company in February, 1904, as a shop apprentice. After spending two and one-half years in various mills of the company, he served as an outside inspector for the frog and switch department. Later he joined the sales force of the company at Steelton, Pa., and from there was transferred to Cleveland, Ohio, where he represented the Pennsylvania and Maryland Steel Companies for two and one-half years.

Next he took a position in Chicago, where he became first assistant to Robert E. Belknap, recently transferred to New York.

The Hilles & Jones Company, Wilmington, Del., has moved its Pittsburgh office to larger quarters in the Oliver building, Room 235.

The Edison Storage Battery Company, Orange, N. J., has removed its Cleveland office to the David Whitney Building, Detroit, Mich.

J. R. McAllister has been elected a director of the Electric Storage Battery Company, Philadelphia, Pa., succeeding Rudolph Ellis, deceased.

The Sprague Electric Works of the General Electric Company has opened a sales office in the Provident Bank building, Cincinnati, Ohio, in charge of Frank H. Hill as manager.

W. E. Hardy, who has been in charge of the sales of the mechanical rubber goods division of the Diamond Rubber Company and the B. F. Goodrich Company, has been appointed sales manager of the Boston Belting Company, Boston, Mass.

Reports are current that the Baldwin Locomotive Works will sell to the Midvale Steel & Ordnance Company the buildings and land at Eddystone, Pa., now under lease to the Remington Arms Company, which was recently acquired by the Midvale interests.

The George E. Molleson Company, sales agents for iron and steel products and railway supplies and New York representatives for the Tyler Tube & Pipe Company, Washington, Pa., has moved its offices from 50 Church street to 30 Church street, New York.

W. Hoyt Weber & Co., New York, have completed arrangements with the MacDonald Car Buffer, Limited, of Montreal and Pittsburgh, whereby they will represent the latter in the eastern part of the United States. The members of the firm are W. Hoyt Weber and Horatio S. Schroeder. The firm has offices in the Vanderbilt Concourse building.

The New York Air Brake Company has been awarded a medal of honor for its exhibit at the Panama-Pacific International Exposition. By a more recent decision of the superior jury of awards, the final official authority, the company has also

been awarded a grand prize, the highest award, for its "PS" electro-pneumatic equipment.

The Hydraulic Press Manufacturing Company, Mount Gilead, Ohio, has been awarded two prizes by the International Jury of Awards at the Panama-Pacific International Exhibition. They are the grand prize from the department of agriculture for press machines and a gold medal from the department of machinery for forcing presses and equipment.

Robert E. Belknap, district sales manager of the Pennsylvania Steel Company at Chicago, has been transferred to the New York office as district sales manager, succeeding R. W. Gillespie, recently appointed general manager of sales. Thomas Blagden, Jr., has been appointed assistant sales manager at New York, and R. W. Reid, who has been assistant sales manager in the New York district, has been appointed district sales manager at Steelton, Pa.

Walter H. Evans, of Chicago, has been appointed western railroad department manager of the U. S. Metal & Manufacturing Company, New York. Mr. Evans was recently manager of the motor gear department of the Edgar Allen American Manganese Steel Company, Chicago, and previous to his connection with this company was connected with several electric and steam roads in the capacity of master mechanic and superintendent of motive power. Mr. Evans will make his headquarters in the McCormick Building, Chicago.

H. A. Varney, general sales manager of the National Boiler Washing Company, Chicago, has resigned to become manager of the railroad department of the Smith-Totman Company with offices in the People's Gas building, Chicago. Mr. Varney was born at Spencer, Iowa, on September 9, 1877, and was educated at the public schools of his native city and at the Iowa Agricultural College. He came into the railway supply field in 1906 as a member of the construction force of the W. L. Miller Heating Company. He joined the sales force of the National Boiler Washington Company in 1909, and was later promoted to the position with that company which he now resigns.

A. E. Ostrander has been appointed mechanical engineer of the American Car & Foundry Company, and is succeeded as assistant mechanical engineer by H. C. Lunger, who was formerly chief estimator. W. H. Selden, formerly assistant chief estimator, succeeds Mr. Lunger. Mr. Ostrander, who succeeds John McE. Ames, who recently resigned as mechanical engineer to go into other business, began railway service on the New York, New Haven & Hartford, serving in several different capacities in various departments on that road. Later he was employed in the engineering office of Cornelius Vanderbilt, leaving there to accept a position with the Standard Steel Car Company. He entered the service of the American Car & Foundry Company in 1903, and has been with that company continuously since that time.

The Westinghouse Electric & Manufacturing Company announces the following awards received at the Panama-Pacific Exposition: The grand prize on the 4,000 h.p., 650-volt d.c. double unit Pennsylvania electric locomotive mounted on a turntable under the dome of the Transportation Palace; the medal of honor on alternating current and direct current industrial motor and control apparatus; on precision instruments; on Le Blanc condensers; on motor-generator sets for moving picture machines and on high voltage oil switches; the gold medal on a number of different classes of apparatus, among which are steam turbines, alternating and direct current generators, alternating and direct current railway motors, transformers, rectifiers, starting, lighting and ignition systems, switchboards and accessories, and mining locomotives. The Westinghouse Electric & Manufacturing Company was also awarded the gold medal for the most complete and attractive installation in the Palace of Transportation. It also received a number of silver and bronze medals.

CATALOGS

SCREW CUTTING TOOLS.—The Wells Brothers Company, Division of the Greenfield Tap & Die Corporation, Greenfield, Mass., has recently issued catalog 34 relative to the company's line of screw cutting tools and machinery. The booklet contains a large number of new devices and improvements on old ones and like its predecessors stands in the front rank as a reference book in this line.

STORAGE BATTERY CARS.—Bulletins No. 30, 31, 32 and 34 issued by the Railway Storage Battery Car Co., New York, illustrate and describe a number of city and interurban cars equipped with storage batteries for supplying the driving power. One of the bulletins gives some comparative costs between standard overhead construction and the equipment necessary when Edison batteries are used.

SAND-BLAST APPARATUS.—The Mott Sand Blast Manufacturing Company, New York, has issued four folders dealing with the following sand-blast apparatus which it manufactures: the Mott direct-pressure sand-blast machine, hose type; the Mott sand-blast tumbling barrel; revolving table and cabinet, type G; the Mott type P. V. S. double sand-blast tumbling barrel and Mott sand-blast accessories.

FLUE TOOLS.—Gustav Wiedeke & Co., Dayton, Ohio, have recently issued a 96-page catalog, descriptive of the Ideal flue tools, manufactured by the company. The booklet describes and illustrates the line of Wiedeke Ideal tube expanders, cutters and accessories. Each tool mentioned is described, and in connection with the description there are given specifications, price lists and detailed views of the tool and its parts.

RAILROAD SPECIALTIES.—The Q & C Company, New York, has issued an elaborate catalog, illustrated in colors, describing its various products, including the Bonzano joint, the Vaughn rail anchor, tie plates and other track appliances, Ajax vestibule diaphragms, snow flangers and the Ross-Schofield system of circulation for locomotive boilers. The various features are illustrated in detail separately and in actual service.

LOCOMOTIVE CRANES.—The Browning Company, Cleveland, Ohio, has recently issued two rather unusual folders relative to the use of the company's cranes in railway service. One is entitled, "How to Be Reasonable About Handling Scrap Iron and Other Materials," and the other bears the name, "Railroad Construction With Locomotive Cranes." Each folder contains four illustrations, showing Browning cranes at work.

Statement of the ownership, management, etc., as of October 1, 1915, required by the Act of August 24, 1912, of the *Railway Age Gazette, Mechanical Edition* (including the *American Engineer*), published monthly at New York, N. Y.

Editor, ROY V. WRIGHT, Woolworth Bldg. New York, N. Y.
 Managing Editor, None.
 Business Manager, None.
 Publisher, SIMMONS-BOARDMAN PUBLISHING CO., Woolworth Bldg., New York, N. Y.
 Owner, SIMMONS-BOARDMAN PUBLISHING CO., Woolworth Bldg., New York, N. Y.

STOCKHOLDERS:

EDWARD A. SIMMONS, New York. SAMUEL O. DUNN, Chicago, Ill.
 LUCIUS B. SHERMAN, Chicago, Ill. ROY V. WRIGHT, New York.
 HENRY LEE, New York. B. BOARDMAN, New York.
 RAY MORRIS, New York.

BONDHOLDERS:

CLARA T. BOARDMAN.
 ESTATE OF WM. H. BOARDMAN, N. Y.
 SIMMONS-BOARDMAN PUBLISHING COMPANY.
 By E. A. SIMMONS, President.

Sworn to and subscribed before Harry E. French, Notary Public for Kings County, N. Y. (No. 15), whose certificate is filed with the County Clerk of New York (No. 13), and whose commission expires March 30, 1916, on September 29, 1915.

Railway Age Gazette

MECHANICAL EDITION
INCLUDING THE
AMERICAN ENGINEER

PUBLISHED ON THE FIRST THURSDAY OF EVERY MONTH BY THE
SIMMONS-BOARDMAN PUBLISHING COMPANY
WOOLWORTH BUILDING, NEW YORK, N. Y.

CHICAGO: Transportation Bldg. CLEVELAND: Citizens' Bldg.
LONDON: Queen Anne's Chambers, Westminster.

EDWARD A. SIMMONS, *President* L. B. SHERMAN, *Vice-President*
HENRY LEE, *Secretary-Treasurer*

The address of the company is the address of the officers

ROY V. WRIGHT, *Editor*

R. E. THAYER, *Associate Editor* A. C. LOUDON, *Associate Editor*
C. B. PECK, *Associate Editor*

Subscriptions, including the eight daily editions of the *Railway Age Gazette* published in June in connection with the annual conventions of the *Master Car Builders'* and *American Railway Master Mechanics' Associations*, payable in advance and postage free:

United States, Canada and Mexico..... \$2.00 a year
Foreign Countries (excepting daily editions). 3.00 "
Single Copy 20 cents

Entered at the Post Office at New York, N. Y., as mail matter of the second class.

WE GUARANTEE, that of this issue 7,300 copies were printed; that of these 7,300 copies 6,478 were mailed to regular paid subscribers, 102 were provided for counter and news companies' sales, 276 were mailed to advertisers, exchanges and correspondents, and 444 were provided for new subscriptions, samples, copies lost in the mail and office use; that the total copies printed this year to date were 74,000, an average of 6,217 copies a month.

The RAILWAY AGE GAZETTE, MECHANICAL EDITION, and all other Simmons-Boardman publications are members of the Audit Bureau of Circulations.

Don't Miss This Competition

The competition which closes on January 1, 1916, and which was announced for the first time in our November issue, page 554, should prove the largest and best that we have yet held. Every wide-awake officer or foreman has met with success in trying out some idea or scheme to secure more effective and more efficient work from his staff or department. Sometimes a very little thing will do much to inspire and encourage the men to greater and more efficient efforts. Cutting out lost motion and useless work and making every move count has resulted in important gains being made in more economical operation or in increased capacity of a shop, engine house, car repair yard, drafting room or other unit. We want to bring out these things and get the benefit of your experience. For each of the best three letters, from a practical standpoint, telling of experiences of this sort, prizes of \$10 will be awarded. They must be received on or before January 1, 1916, and must not contain more than 700 words. Other letters which may be selected for publication will be paid for at our regular rates.

Efficiency in Railroad Shops

"How the Old Man Beat Them to It" sounds a bit flippant or undignified as the title of an article in a strictly technical publication of the nature of the *Railway Age Gazette, Mechanical Edition*. Be that as it may, the article is a most readable one and Mr. Wolcomb, the author, takes advantage of the opportunity to drive home the fact that, after all, efficient and economical shop management is based strictly on the application of simple, sound common sense. If the foremen and the men in the ranks can be encouraged to make suggestions, and the best of these are followed up with good judgment, remarkable savings may often be made at little or no expense for additional equipment and facilities. This has been thoroughly demonstrated in other departments of railway work. For instance, take the safety first movement; the freight loss and damage prevention campaigns, which are bearing such fruitful results; or the progress which has been made on a number of roads in improving car and trainloading by educational methods and co-operation on the part of all of the employees interested. The success of all of these movements has depended largely on individual effort and the following up of suggestions which have

VOL. 89

DECEMBER, 1915

NUMBER 12

CONTENTS

EDITORIAL:

Don't Miss This Competition.....	603
Efficiency in Railroad Shops.....	603
The Value of Home-Made Tools.....	604
Locomotive Boiler Inspection Competition.....	604
The Car Inspector Problem.....	604
Getting Results From a Big Engine Terminal.....	604
A Field for the Special Investigator.....	604
Our Change in Name.....	605
Prosperity and the Railways.....	605
New Books	605

GENERAL:

Swiss Railways Dynamometer Car.....	606
Failure of Fusible Tin Boiler Plugs.....	612
Uni-flow Cylinder for Locomotives.....	612
Southern Steam Tender Locomotive.....	613
Southern Pacific Six-Volt Electric Headlight Equipment.....	613
The Mikado vs. the Consolidation.....	615
Locomotive Coal Consumption	617

CAR DEPARTMENT:

Car Derailments, Causes and a Remedy.....	619
Electric Lighting of Passenger Cars.....	620
New M. C. B. Experimental Couplers.....	622
Effect of Moisture in the Air Brake System.....	623
Making Good Car Inspectors.....	624
Design of Steel Passenger Equipment.....	625

Why It Is Hard to Get Good Car Inspectors.....	627
Expansion Joint for Water Heater.....	628
"The Doctor of Cars".....	628
Proper Handling of Equipment.....	629

SHOP PRACTICE:

Reclaiming Material at Local Shops.....	631
The Apprentice School	633
Oil Burning Blacksmith Forge.....	633
Barometric Condenser as an Open Water Heater.....	634
The Boiler Inspector and His Job.....	635
Tire Heater	638
Two Good Suggestions	638
"How the Old Man Beat Them to It".....	639
Take a Real Interest in the Apprentice.....	641
Device for Forming Sill Steps.....	641
How Can I Help the Apprentice?.....	642

NEW DEVICES:

Piston Valve with Automatic Cut-Off for Air Compressors.....	643
Manual Slack Adjuster for Freight Cars.....	644
Compressed Air Grease Cups.....	645
Cast Steel Truck Side Frame.....	645

NEWS DEPARTMENT:

Notes	646
Meetings and Conventions.....	647
Personals	647
Supply Trade Notes	649
Catalogs	650

been advanced by men in all branches of the service. Some of the very best suggestions have come from the rank and file. Encourage the men in your shop or department to co-operate in this way.

The Value of Home-Made Tools

One statement in Mr. Wolcomb's article on "How the Old Man Beat Them To It" may be questioned as to correctness. It is this: "Instead of buying new machines now, the foremen and men get their heads together and build a machine at much less cost that does the work just as well as an expensive tool. You can see for yourself the great number of home-made 'kinks' around the shops and yard." In all probability the author referred to special tools or kinks for jobs which could not be handled to advantage on standard machine tools, or which were not numerous enough to justify manufacturers in developing special machines to handle them. It is doubtful if any railroad shop or repair yard can develop a satisfactory machine tool at a cost nearly as low as that for which it could be purchased from a manufacturer who specializes in the building of the same type of tool. On the other hand, savings may often be made in the railroad shop by contriving simple tools or apparatus which will enable a standard machine to better meet the requirements for some special class of work.

Locomotive Boiler Inspection Competition

Ten papers were received in the locomotive boiler inspection competition which closed on November 1. The first prize of \$35 has been awarded to T. T. Ryan, roundhouse foreman of the Atchison, Topeka & Santa Fe at La Junta, Col. In general he discusses the qualifications of a successful inspector and the facilities and methods which should be placed at his disposal. In addition, he emphasizes the vital necessity of coaching these men in order that they may develop to the fullest extent, and of backing them up and supporting them so that there may be no question as to their authority in seeing that repairs are fully and properly made. We also publish with Mr. Ryan's article the contribution by W. J. Gillespie, boiler inspector of the Pittsburgh & Lake Erie at McKee's Rocks, Pa. Mr. Gillespie's treatment of the subject is very different from that of Mr. Ryan and goes more fully into the actual details of making the inspections. A number of splendid suggestions are made in the other contributions which were received, the best of which will be published in following issues.

The Car Inspector Problem

J. H. Harrigan, in an article on "Why It Is Hard to Get Good Car Inspectors," printed on another page of this issue, gives two reasons for the lack of proper material from which to develop good inspectors. These are low pay and long hours. Those who are at all familiar with the requirements of this position can realize the force of these reasons; and the first cause—low salary—applies with equal force more or less generally to car department foremen. For instance, the foreman of an important steel car repair shop receives a salary of \$75 a month; the foreman of the locomotive boiler shop, hardly a stone's throw away, receives a monthly salary of \$150. It may be argued with more or less force that the boiler shop foreman is in charge of more important or more exact work and requires a wider knowledge and greater experience than the steel car repair shop foreman. Grant that this is so; but does it require any less effort or executive ability to get results from a group of typical car repair men than from trained boilermakers, and are these two salaries at all proportionate? Here is another case: A car foreman at an important point receives \$80 a month, which is about the same amount as is paid to the car inspectors at that terminal. At least three men working on the car repair tracks regularly earn from \$100 to \$120 a month on a piecework basis. Will these men give up their jobs to be promoted to a salaried position of greater re-

sponsibility, necessitating harder work and longer hours, for from 20 to 33 per cent less compensation? What are the possibilities for further advancement which would justify them in taking this step?

Getting Results from a Big Engine Terminal

We have not had a competition of special interest to engine house men for some time; but the work at an engine house is of such a nature that new problems are constantly arising requiring new practices to be developed. In periods of heavy traffic, or, indeed, at almost any time, the engine terminal is a strategic point in the operation of a division, and the efficiency of the division or of the road is largely dependent on it. It is a vitally important task, then, to organize the forces and operate the terminal as a whole in such a way as to co-operate to the best advantage with the other parts of the operating organization. For an engine house, large or moderate size, what is the best plan of organization? It is understood, of course, that it will depend to a certain extent on local conditions of traffic, including the relative number of freight and passenger trains, and the class of freight trains. In attempting to answer this question, therefore, the special conditions under which the organization has proved successful should be outlined roughly. What equipment is necessary, both in the engine house and outside, to secure the most effective results? What about the labor problem? What special methods of operating a terminal or any one of its important departments have proved most successful? How can terminal delays to locomotives best be avoided? Are there any methods that can be applied to engine houses or their organization, in general, to prevent engine failures? These are some of the questions which might profitably be considered in connection with a study of "The Handling of a Big Engine Terminal," and are only intended as suggestions. We will give a prize of \$35 for the best article on this subject, judged from a practical standpoint, which is received on or before February 1, 1916. Other articles which may be accepted for publication will be paid for at our regular space rates.

A Field for the Special Investigator

It is of paramount importance that the mechanical department officers keep thoroughly in touch with the service performed by both the cars and locomotives under their control. Special men, or general inspectors, as they are sometimes called, should be assigned to this work—men who have had sufficient technical education and practical training to diagnose the troubles that may be found in all types of equipment. When a new device is installed it should be the duty of these men to see that it is handled properly and to follow it in service to determine whether or not it is advisable to use it generally, or whether it would serve better on certain classes of equipment only. When an epidemic of trouble occurs, such as hot boxes, leaking tubes, etc., these special investigators would be in an excellent position to ferret out the causes and apply the remedy at the root of the trouble. By concentrating the investigation of these problems in the hands of one man far better results will be obtained than by attempting to judge the merits of any case from the special reports of the various master mechanics.

When the purchase of new power or cars is considered these men should make a study of the conditions in order that the most suitable equipment may be procured. An excellent example of what might have been accomplished, had this plan been followed, is found in the case of a certain large road. A few years ago it purchased a large number of fairly heavy superheater Mikado locomotives. A study of the conditions after they had been in service for some time showed that locomotives of materially less power, superheater Consolidations, would have answered the purpose fully as well and at less investment cost. The determination of the kind and the construction of equipment is left too much in the hands of the builders. Not that their advice should

not be solicited, for they, being specialists, are in a position to offer great assistance. Their experience, however, is general and is gained from dealing with many roads. They have no opportunity to know the special conditions existing on each road.

Another field for these special investigators is in the determination of the tonnage ratings of the power. The mechanical man should know what the locomotives are capable of doing. If they are not performing their full duty investigations should show the reasons. The trouble may be due to the design or it may be due to improper maintenance. In both cases the mechanical officers will have a complete and concise report from one man and they will be in the best position possible to apply the remedy.

Our Change in Name

Railway Age Gazette, Mechanical Edition, is a bulky and unsatisfactory name for a publication. While it defines the field that is covered, it makes unnecessary labor in correspondence and reference and is often confused with the weekly edition of the *Railway Age Gazette*. It was decided some time ago to change to a more simple and less confusing name; this change will be made in our next number, January, 1916. The selection of the new name was no easy task. Two requirements had to be filled—the name must be short, and it must fully define the scope of the publication. Obviously it was necessary to include the term *Railway* or *Railroad*. The shortest term to express in a general way the field covered in the design, maintenance, repair and operation of motive power, rolling stock and shop equipment seemed to be covered by the word *Mechanical*. The words "*Railway Mechanical*" being incomplete as a title, the selection of a third term became necessary and, literally, hundreds of suggestions were made as to this in the months during which the change has been under consideration. The name decided upon was *Railway Mechanical Engineer*.

This on first thought may meet with a certain amount of criticism, since it is similar to the title of an officer whose duties are confined within comparatively narrow limits. We prefer, however, to consider the term in a broader sense, in that all of the operations in the motive power and car department are included under the broad head of mechanical engineering. Be assured, therefore, that the change in name does not mean the narrowing of our efforts. Indeed our plans for the coming year contemplate the publication of a journal which will be bigger, better and more interesting than ever before.

Certain improvements will be made in our January, 1916, issue which we believe will add much to the attractiveness and value of the paper. Watch for this first issue of the new year. The name will be new, but we hope it will occupy an even greater place in your affections. And, by the way, our circle of friends has enlarged greatly during the past 12 months—an increase of over 74 per cent in paid subscribers—and we hope that it will broaden still more during the coming year. May we also invite your attention to the completeness of the annual index which accompanies this issue and which covers the June Daily issues of the *Railway Age Gazette*, which are published during the June mechanical conventions and are furnished free to all of our subscribers.

Prosperity and the Railways

An era of prosperity is at hand and will be most welcome. The past two years have been depressing, especially so to the railroads, and railway men in general have been sorely tried. The very existence of the railroads is dependent on the prosperity of the country, as the increase in the number of roads passing into the hands of receivers during the past few years may well indicate and, on the other hand, the existence of prosperity is in a large measure dependent on the railroads. A boom in business means that the railways will be called upon to transport large quantities of freight. Without the necessary equipment to handle this freight the continuance of prosperity is going to be severely handicapped, and this is one

of the most serious problems confronting the railways to-day.

It is estimated roughly that all the railways in this country require approximately 150,000 new freight cars a year to keep their equipment up to standard. In 1914 only 80,264 were ordered and so far this year our records show that only 85,000 have been ordered, which makes a deficit of about 120,000 cars. To complicate matters still further, the question of delivery of those cars recently ordered and those that will be ordered in the near future, is a very serious one.

It has been stated by a vice-president of one of the largest car building companies in the country that, on account of the suddenly increased demands for steel products and the large amount of unfilled orders reported by the steel companies, more than one-third of the steel required for car contracts now placed will not be delivered until after July 1, 1916, and that little or no equipment ordered after January 1, 1916, can be completed before the close of that year. In view of these conditions, the railways, during the next year, are liable to be placed in an embarrassing position from a shortage of cars. In addition to this, the prices for equipment have been increased anywhere from 15 to 25 per cent in the last six months.

That strenuous steps should be taken to prevent the recurrence of such a notorious car shortage as occurred in 1907, and which so irritated public opinion, should be readily apparent. With the steel market thoroughly congested, there seems but one alternative left for the railways to follow and that is an active and determined effort to place those cars they already have in first-class condition. According to the last reports, June, 1914, there were about 8.6 per cent of the freight cars in shops undergoing repairs, and, considering the financial stringency since then, the percentage at the present time cannot be far from 10 per cent. By increasing the car shop forces for the purpose of putting these cars in service, and following a systematic campaign to repair defective equipment, it is believed possible to bring the percentage of cars in shops down to 5 or even 4 per cent. This would mean that the number of cars available for service would be increased some 135,000 or 160,000, which would do much toward alleviating a shortage. In view of the present relatively high cost of equipment and with a possible still further increase, this plan may also prove to be a profitable financial expedient. In all events, it should be seriously considered, as a recurrence of a serious car shortage is sure to tear down much of the constructive work that has been done in the past few years in influencing public opinion in favor of the railroads.

NEW BOOKS

Electric Railway Handbook. By Albert S. Richey, consulting engineer, and professor of electric railway engineering, Worcester Polytechnic Institute, Worcester, Mass., assisted by William G. Greenough. Bound in leather. 817 pages, 4 in. by 6 3/4 in. Illustrated and indexed. Published by the McGraw-Hill Book Company, Inc., 239 West 39th street, New York. Price \$4.00.

This is the first edition of a book of pocket size in which the aim has been to get together in compact and usable form a large amount of information which the electric railway engineer frequently requires but often finds only after an extended search through mechanical, electrical or civil engineers' handbooks or the files of technical journals. It is divided into eleven sections, section one dealing with roadbed and track; section two with buildings; section three with train movements; section four with railway motors; section five with controlling apparatus; section six with current collecting devices; section seven with trucks; section eight with braking; section nine with rolling stock; section ten with transmission and distribution, and section eleven with signals and communications. The book is printed on thin paper, the typographical work is excellent, and illustrations are liberally employed. It is a book which should prove of more than ordinary value in electric railway work.

SWISS RAILWAYS DYNAMOMETER CAR

Equipment Includes Dynamometer and Ergometer
Integrators and Integrating Cylinder Indicators

BY H. A. GAUDY

Mechanical Engineer, Swiss Federal Railways, Berne, Switzerland

As a result of the large amount of rolling stock purchased in the last few years and the continuing progress made in the improvement of the steam locomotive, dynamometer cars have come into extensive use on the principal European railways, thus enabling by the results obtained accurate decisions to be made on questions relating to economical train operation. The need of reliable measuring instruments for use in conducting tests was recognized by the management of the Swiss Federal Railways, and accordingly it was decided to secure a suitable dynamometer car.

The designs were prepared in the office of the chief mechanical engineer after a thorough study of all the principal questions involved in the selection of the type and general arrangement to be adopted as well as the apparatus and instruments required. The car proper was built by the Swiss Industrial Company, Neuhausen, and orders were placed for the equipment with Amsler Brothers, Schaffhausen, a firm noted throughout the world for the manufacture of scientific instruments. The car was delivered late in 1914 and embodies a testing laboratory equipped with the most modern instruments, measuring apparatus and auxiliary devices yet applied to a vehicle of this

first one with a length of 13 ft. 1 $\frac{5}{8}$ in. serves as a working office and recreation room. Upholstered leather-covered seats, movable armchairs and a spacious extension table make up the equipment of this room. A short aisle leads to the back platform, giving access to a small toolroom with an outfit enabling the making of small running repairs, and two lockers for supplies. Adjoining the tool room is a lavatory and toilet room. Owing to the comparatively short main lines of the Swiss railway system there was no necessity to arrange for living accommodations in the car itself, thus reducing the number of rooms required to a minimum and enabling the length of the car to be kept within reasonable limits. The car has closed vestibule platforms in accordance with the standard through car design, and the inside finish is very simple.

Electricity is used for the lighting, a storage battery and an axle-driven dynamo being provided for this purpose. The car is heated by steam taken from the locomotive; it was not considered necessary to provide an independent heating device. The Westinghouse automatic and non-automatic quick action air brake acts on the wheels of three axles only, the rear axle of the forward truck being left free from brake shoes because the

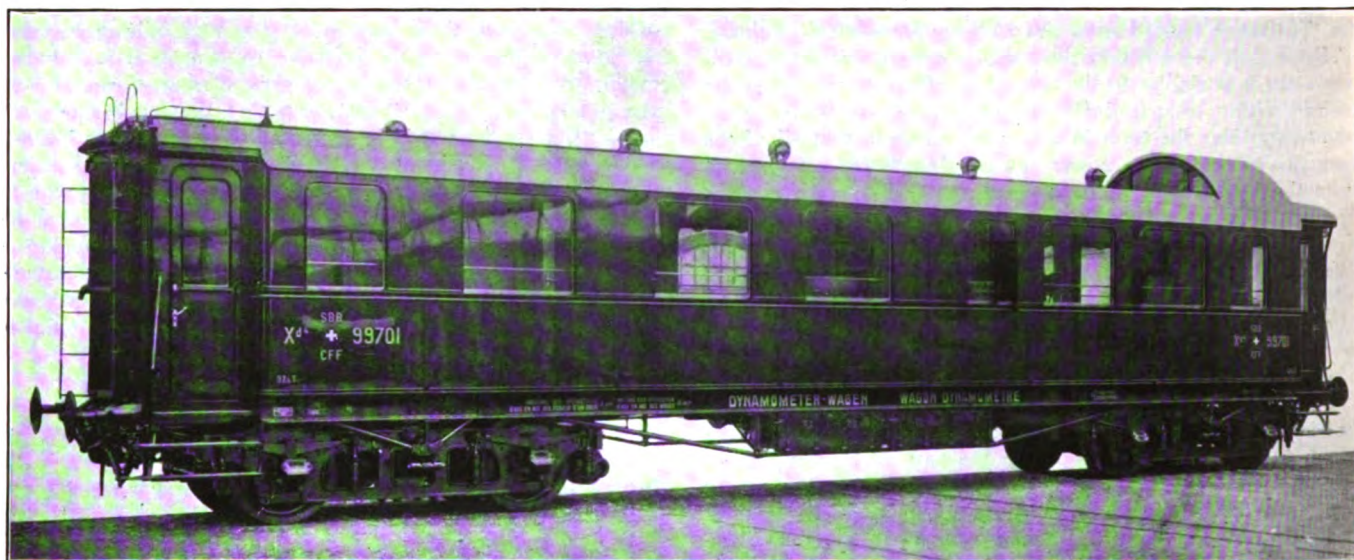

Dynamometer Car for the Swiss Federal Railways

kind, the design being intended to meet all the requirements of road tests of the efficiency of locomotives, the resistance of cars or trains of different kinds, and the amount of power required for the propulsion of trains on certain lines under different running conditions.

The car body rests on two four-wheel trucks of the railway's standard type. The underframe is made entirely of steel and is of a very strong design. The longitudinal side sills are arranged double in accordance with the extraordinary conditions to be met with in service. The interior of the car is divided into four compartments. The first room at the dynamometer end is the test room, 21 ft. 4 in. in length, where all the measuring apparatus is located. A cupola with an elevated seat just back of the front vestibule permits a good view towards the signals and the track ahead, as well as over the train behind and into the engine cab. A second compartment adjoining the

paper driving mechanism and other apparatus receive their motion from this axle.

The car measures 57 feet over all and weighs 82,000 lb. when in full working order. The width has been limited to 9 ft. 2 $\frac{3}{4}$ in. instead of the standard 10 ft. This was done in order to permit the attachment of mirrors outside of the car, giving a view of the road ahead from the observer's station near the instrument table.

DYNAMOMETER

Although nearly all European dynamometer cars are equipped with spring dynamometers, either plate or helical, it was decided by the builders to use the hydraulic principle in the Swiss car, because of the fact that with increasing capacity spring dynamometers were growing very cumbersome as well as because of the difficulty of examining and recalibrating the springs from time

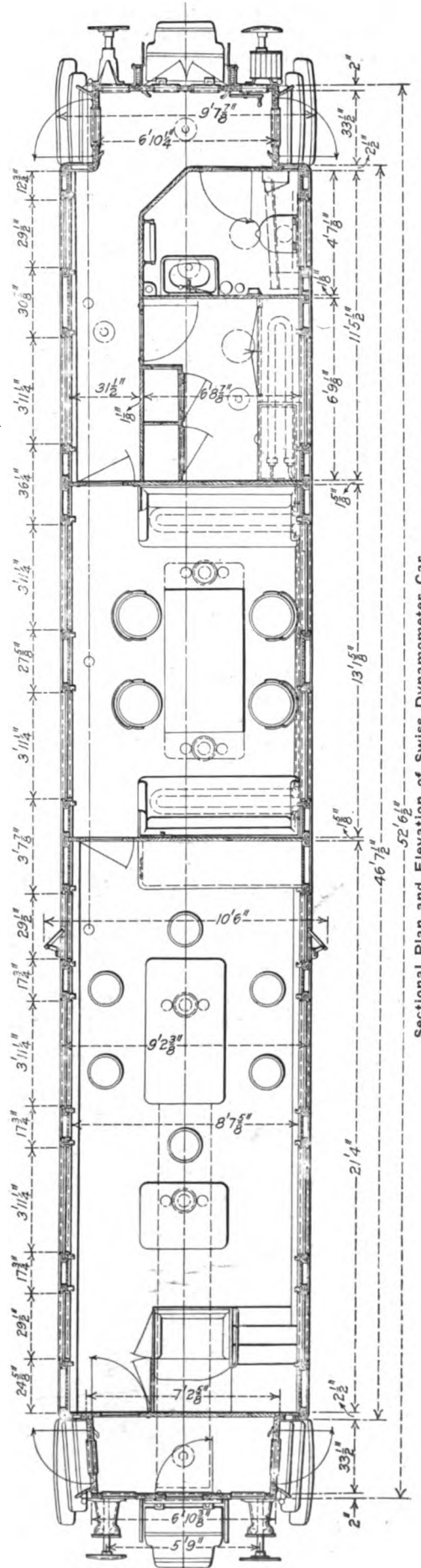
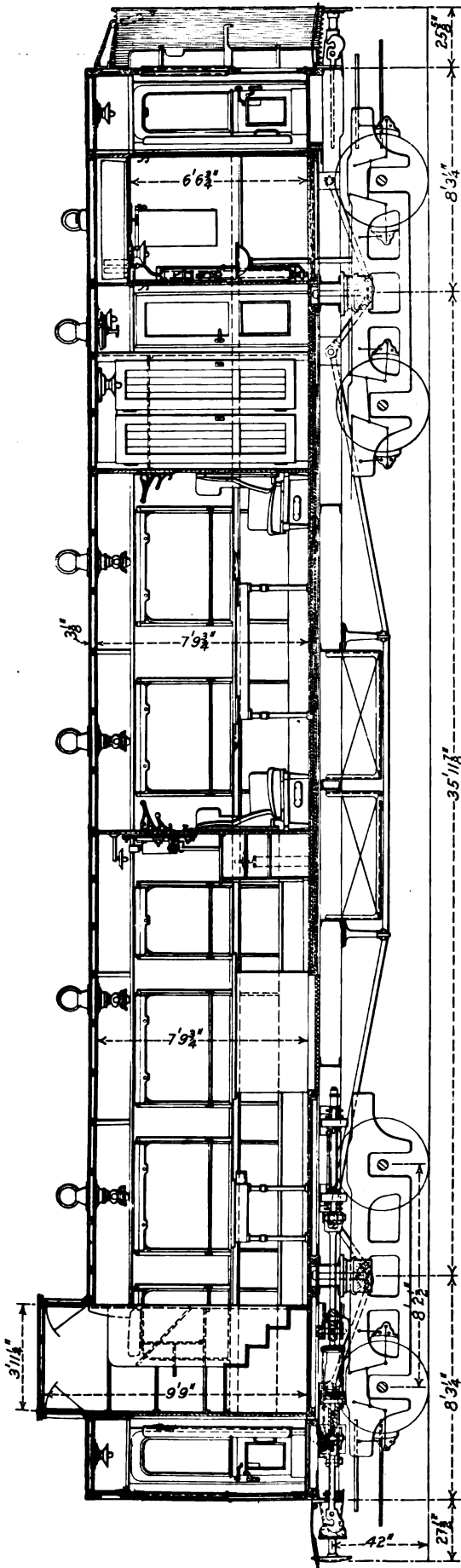

Sectional Plan and Elevation of Swiss Dynamometer Car

to time. The general principle of the hydraulic dynamometer is widely known. The Swiss apparatus, however, embodies some noteworthy features. No other means are provided to pack

gage all still use the old-fashioned coupler with a hook in the center and buffers on the sides.

The pressure in the dynamometer cylinders is transmitted

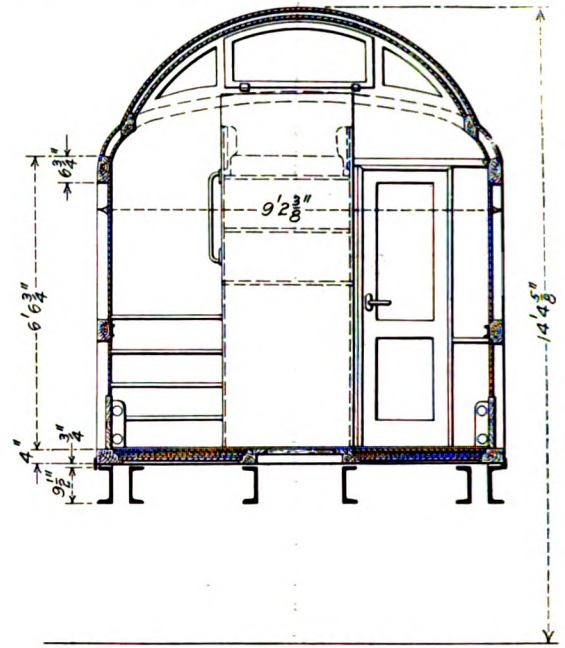
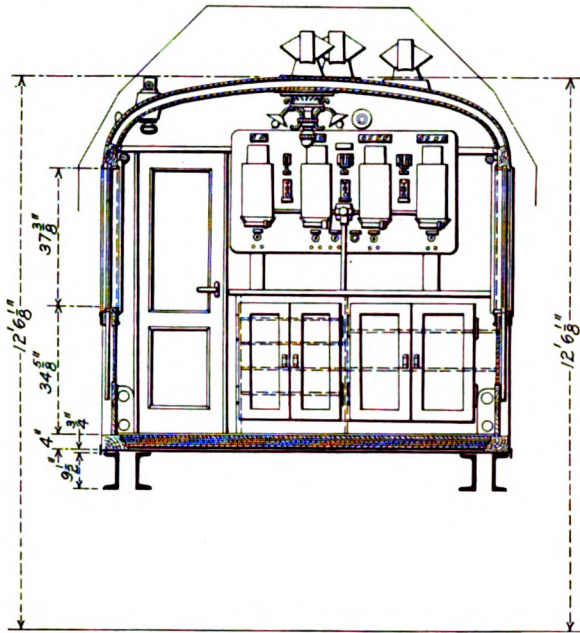

Sections Through the Car Body

the pistons in the cylinders than simply to grind them in so that a perfect fit is assured with the least amount of frictional resistance. There are two pistons of chilled cast steel extending into two cylinders opening on opposite faces of a single block of forged steel. The pressure exerted on the back piston is

through pipe lines to a pair of smaller recording cylinders, arranged in tandem with the piston ends extending opposite each other and located directly underneath the measuring table. The

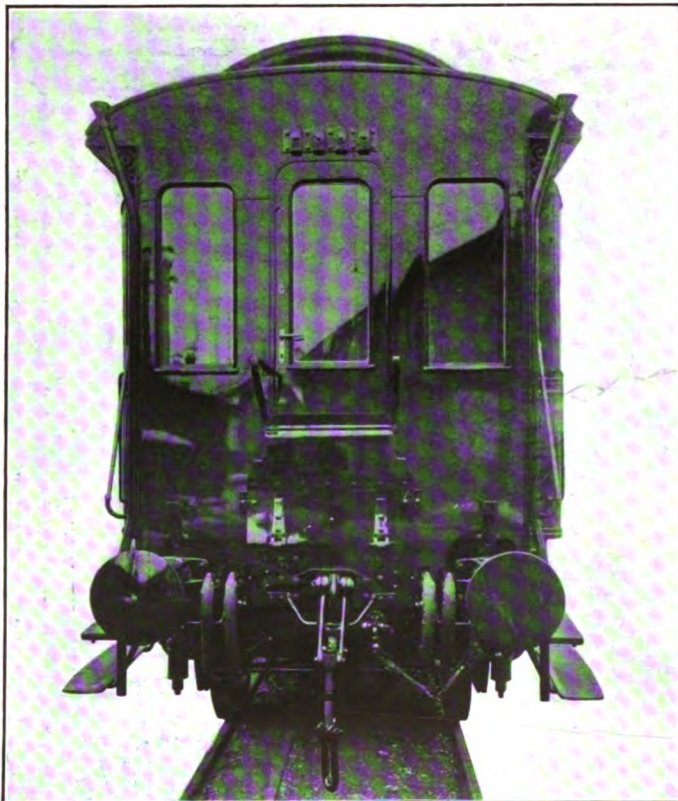

Front End of Swiss Dynamometer Car

derived from the pulling effort, while the one in the front receives the reaction from the pressure on the buffers. It should be kept in mind that the European railways of standard



Interior of the Test Room

pressure there acts upon two differential pistons, permitting by means of a distributing valve the use of either one of two areas. A carefully calibrated helical spring is located between the two pistons; its compression indicates the amount of load resting on the small pistons and by knowing the ratios of the areas of these to the ones in the dynamometer proper, we thus are able to determine the load on the drawbar as well as on the buffers.

These differential pistons are so designed that either one-third, one-half or the whole piston area is exposed to the oil pressure. With this arrangement it is possible, by simply turning the distributing valve, to select any one of three scales for measuring the pulling and buffing load, thus keeping the diagrams for heavy trains within a reasonable space on the chart without sacrificing clearness in the diagrams for light trains. There are separate recording pens for the push and pull, attached to the respective ends of the measuring spring. Since only one of them is working at a time the same space is reserved on the paper for the ordinates of both.

In case small leaks should occur in the dynamometer, for instance in the pulling side, the two pistons, rigidly connected with each other by means of yokes and two longitudinal rods, would move away from their central position. It might then happen that, after a long period of pulling exertions, the rear piston would come in touch with the cylinder end, making

The operation of this apparatus is based on the variation in the position of the instantaneous axis of rotation of a sphere about 4 in. in diameter, resting firmly on two disks, the axes of which are perpendicular to each other. One of these disks is turning at a constant rate, driven by a small 1/100-hp. direct

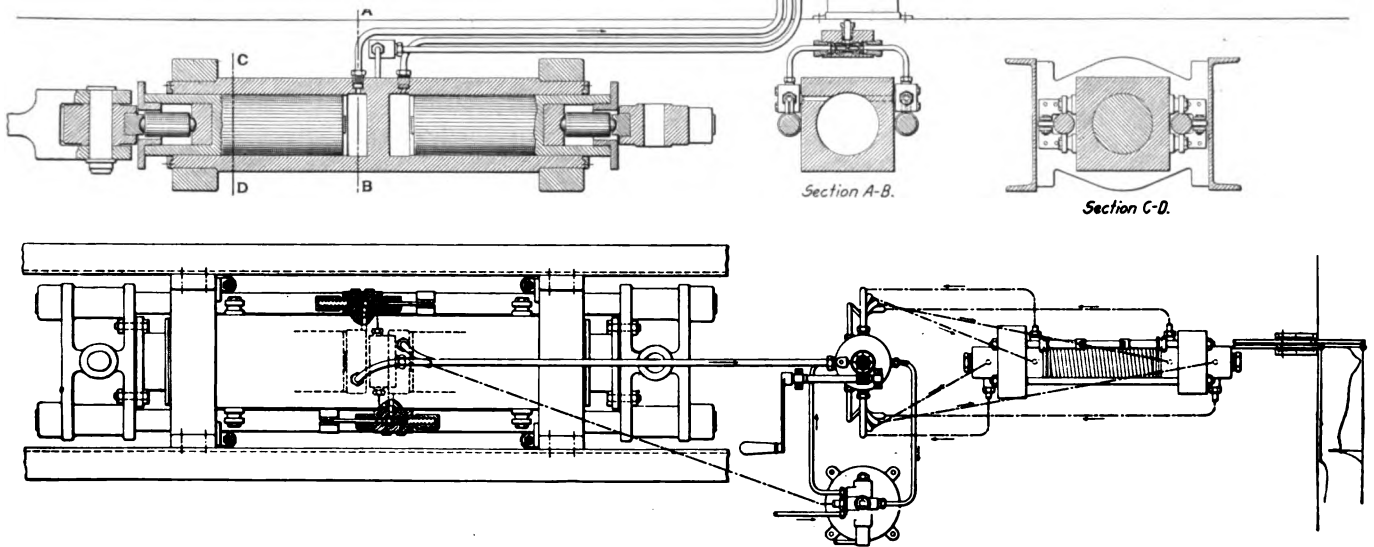

Details of the Dynamometer and Recording Mechanism

further measurements impossible. A means of equalization has been provided which brings the pistons back to their original positions at the instant the slightest change from a pulling to a buffing action takes place. At this instant an intercepting valve with two check valves produces a connection through a pipe line between the two cylinders, thus equalizing the pressure and permitting the pistons to return to their central position. The check valves close and the by-pass between the cylinders is cut off as soon as the central position is reached. Oil is supplied to that chamber which is increasing its volume from a reservoir under atmospheric pressure; to properly fill all the pipe lines, cylinders and valves with oil before starting the tests, another tank is provided which carries about 50 lb. pressure.

The two buffers at the forward end of the car are connected by means of an equalizing lever, the central pivoting point of which carries the drawbar with its hook projecting beyond the bumper beam. Between this pivoting point and the dynamometer a Westinghouse friction draft gear has been inserted, all the reactions being transmitted through it to the dynamometer. The whole draft rigging is carried on ball bearings in order to prevent undue friction. If the dynamometer is not in service, the draft rigging is locked by means of a heavy pin, connecting it directly with the car underframe.

SPEED INDICATORS

The Amsler tachometer, already in use on some of the European dynamometer cars, has been brought to such perfection that it indicates the speed almost instantaneously as a function of the distance covered, differing in fractions of a second only.

current electric motor, while the other has a speed proportional to that of the train. The angle between the axis of the disc rotating at constant speed and the axis of rotation of the sphere thus varies with changes in the speed of the train, the tangent of this angle being proportional to the speed of the train. Two small rollers held in a frame receive their movement from the sphere. They are so located that they always

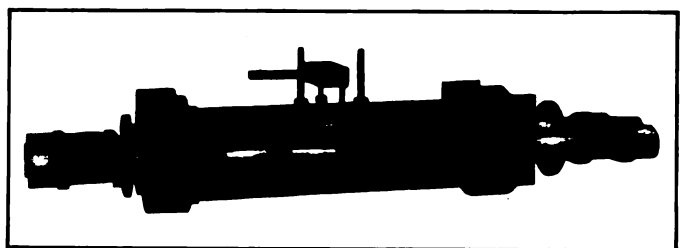

The Dynamometer, Showing the Intercepting Valve and One of the Check Valves of the Equalizing Device

have their path along its equatorial line, following it with changes in the position of its axis of rotation. Suitable gearing transmits the movement of this frame to a dial, permitting the reading of the speed in kilometers per hour, while a recording pen marks a curve on the paper.

Another speed recorder is installed on the measuring table for the purpose of indicating the speed as a function of the time. The special diagram strip for this purpose moves during stops,

registering the minutes and seconds thus consumed. The records on this paper are not traced but punctured and registration is made every three seconds giving the average speed of the two preceding seconds. This speed recorder works satisfactorily and was years ago adopted as standard equipment for all the road engines of the Swiss Federal Railways.

ERGOMETER

This device is designed to measure the work done in overcoming the forces of inertia due to the mass of the train, taking no account of the forces due to air resistance and friction. Its principal part consists of a pendulum suspended underneath the instrument table, oscillating freely in a plane parallel to the center line of the car. If the speed of the train is accelerated, the pendulum, by virtue of its inertia, assumes an angle of deviation back of its middle position, while with the introduction of a retarding effect its position will change in a forward direction. The accelerating and retarding forces are thus determined by the value of the angle given by the varying swing of the pendulum. On an up or down grade this angle is also influenced by the inclination of the track itself, and the weight of the train is considered a force due to inertia.

Let P = force imparting the movement to the train, except frictional and air resistance.

M = mass of the train.

X = the distance run.

g = acceleration due to gravity.

α = the angle of deviation of the pendulum.

then we have

$$P = M g \tan \alpha$$

and the work to overcome the force P over the distance X is

$$A = M g \int \tan \alpha dx$$

This value is computed by a mechanical device designed by

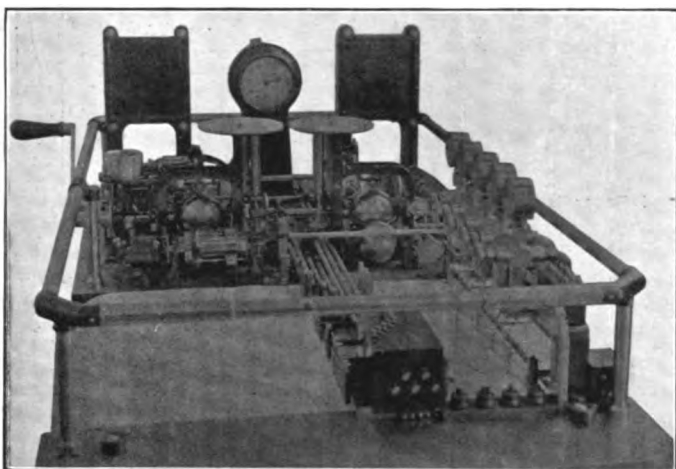

Front View of the Recording Table

Amsler Brothers, consisting of a sphere resting on a small roller, and held in position by two disks. One of the discs receives a turning movement proportional to the speed of the train, while the other is rotated by the sphere itself, the latter changing the axis about which it is revolving in a horizontal plane and in proportion to the angle of deviation of the pendulum. The disk driven by the sphere transmits its movement to a reciprocating bevel gear and thence to a pen on the recording paper. The ordinates of the curve drawn represent the amount of work A , while another pen suitably connected records the swing of the pendulum, giving ordinates showing the force P . A reciprocating or switch-back mechanism keeps the curve within the limits of the space reserved on the paper; when the ordinates have reached the limit line the pen will return to the lower limit, thus forming a zig-zag line. Turning points, however, may show anywhere between the limit lines if, for instance, a change in the track profile, or the beginning of the braking process takes place.

This whole device has proved to be very satisfactory and useful. From the data thus obtained together with that obtained from the dynamometer the average resistance per ton of train on a horizontal track and for any speed can easily be determined. And, furthermore, if we know the indicated horsepower of the locomotive we are also able to work out the total resistance of engine and tender on the same section of line. Instead of calculating with lengthy and doubtful formulas we have a very reliable method of measurement.

INTEGRATING CYLINDER INDICATORS

To determine the power developed in the cylinders of the locomotive, much difficulty arises on account of the relatively small number of diagrams which can be taken during a test with an ordinary indicator. For a given test run the average indicated power could be calculated only approximately. An important innovation in the form of an integrating indicator has

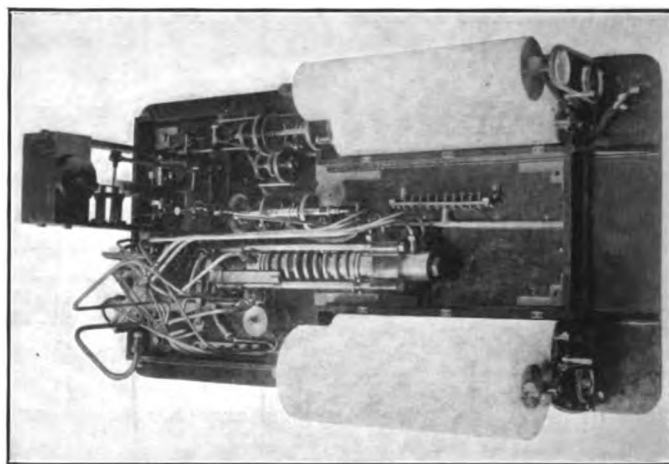

The Under Side of the Recording Table

been designed which makes possible the registering of the work done in every cylinder cycle. This device consists of an ordinary outside spring indicator to the end of the piston rod of which is connected a lever rigging. This is attached to a small disc which rests upon the top of the paper drum, being held in contact with it by a spring. Any increase or decrease of steam pressure in the locomotive cylinder results in a corresponding radial displacement of the disc on the end of the drum, the distance from the drum center being proportional to the pressure in the cylinder. The oscillation of the drum about its axis through the action of the reducing motion induces a rotation of the disc, which varies in amount with its distance from the drum center. The rotation of the disc is transmitted to a counting apparatus. From the difference in readings of the counter at the beginning and end of any period of time the mean indicated horsepower for that period may be readily computed. As it is a difficult task to take readings from the counters mounted directly on the indicators an attachment has been added to the device permitting the transmission of all the values to a receiving apparatus similar to the one on the engine, but located in the car, by means of electric contacts. This arrangement makes possible the determination of the indicated horsepower over any distance of the line under any condition of weather, time, etc. Beside the receiver there are magnet pens which make marks on the recording paper from which the horsepower may be computed in the manner outlined above. Provisions are made for four indicators of this type, thus permitting the complete determination of the power on one side of four-cylinder balanced compound engines.

OTHER INSTRUMENTS

The measurement and recording of the work done at the

drawbar in meter-kilograms is done by a device which operates on the same principle as that used with the ergometer. The pen marks a curve whose ordinates are proportional to $A = P dx$, where P represents the instantaneous drawbar pull and x the distance covered by the train. It also includes a switchback bevel gear transmission mechanism making the curve in a zig-zag form, to keep within space limitations on the paper. Three different scales are available, corresponding with those provided for the dynamometer record. To determine the total work done at the drawbar for a given length of track the number of zig-zags in the curve is multiplied by a constant the value of which depends upon the scale being used. For a check and to facilitate quickly reading off the values at any time a counter is attached to the apparatus.

The drawbar horsepower is measured by an instrument similar in operation to the Amsler speed recorder, consisting of a constant speed disc from which a sphere is rotated, as well as a

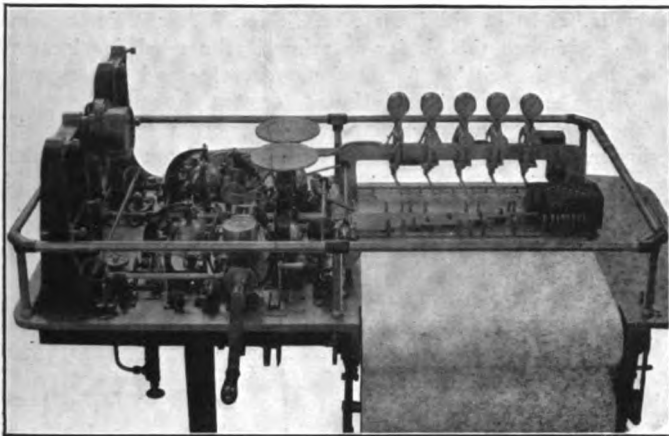

A Side View of the Recording Table

second disc the speed of which is determined by the apparatus used in recording the work done on the drawbar. The horsepower is recorded in the form of a continuous curve to one of three scales, corresponding to the three steps in the load scale.

Wind resistance is measured by a device based on the principle of the Pitot tube. There are two tubes extending about 30 in. over the top of the roof near the rear end of the car, the upper ends of which are bent at right angles, the opening of the front one pointing forward and the other backward. These tubes are in communication with a receiver underneath the instrument table, which consists of two hollow cylinders about 8 in. in diameter carried on the ends of an equalizing lever. One end of each cylinder is open and two vessels of ring section filled with mercury are provided, in which these ends are submerged. When the train is in motion air enters the forward tube and effects an increase in air pressure in its cylinder while in the other one the pressure is decreased. Equilibrium is thus destroyed and the equalizing lever inclines against the side of less pressure. This movement is transmitted by means of a small rod passing through the table and acting upon a calibrated indicator spring, to which a recording pen is attached. This is a newly developed device and it has yet to be thoroughly tried out. However, the indications are that it will be possible to determine a proportion between the ordinates of the recording pen and the component of wind pressure directly in front of the moving train. Experience has shown that vibration and shocks do not affect the stability of the equalizing lever and that any movement of this rigging is caused only by the difference of air pressure in the tubes.

For the close investigation of brake performance Kapteyn apparatus has been in extensive use. This has undergone essential modifications in an arrangement designed by Amsler Brothers which is placed on the recording table adjoining the

other instruments. The radial and tangential forces resulting from the action of the brake shoes against the wheels are measured by means of three hydraulic cylinders interposed in the brake rigging. Two of these cylinders form a part of the hangers for the front brake shoes of the forward axle of the front truck and serve to measure the tangential forces, while the third one is placed in the brakerigging at the center of the brake beam and indicates the radial force.

This arrangement can be used for the determination of the coefficient of friction between the wheels and brake shoes in testing the materials of which the brake shoes are made. Three other indicators record the pressures in the brake cylinder, in the train pipe and in the auxiliary reservoir during each braking period. Provisions are also made for an electric contact on the engineer's valve in the engine cab, connected with a special recording device, so the length and the time of stop can easily be measured. The pens of this recording apparatus can be taken off or put into working order at any time desired, so they may be out of the way when not required.

All the apparatus and registering devices are mounted on a cast iron recording table firmly secured to the car underframe. All the records are made on a continuous chart carried on rolls about 25½ in. in width. The travel of the paper may be regulated to 20, 100 or 600 mm. for each 1,000 meters (1.26, 6.30 or 37.8 in. per mile) and an automatic reversing arrangement causes the paper to run in the same direction whether the car is running

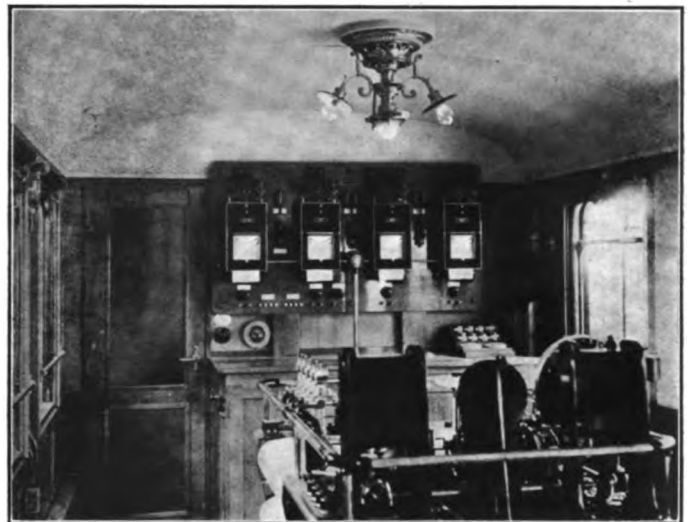

A View of the Recording Apparatus for Electric Traction

backward or forward. During brake tests the paper travel may be at the rates of 1 mm., 5 mm. or 30 mm. per second.

Magnets control seven electric pens, two of which are marking the minutes and each 1.3 or 6 seconds; the third one is the distance pen for each kilometer traveled and for marks due to passing of stations and other points on the line; the last four pens are reserved for recording the values from the integrating steam indicators.

The motion derived from the rear axle of the front truck, which serves for all the apparatus needing a movement proportional to the travel of the car, is transmitted from the axle to the main drive underneath the table by means of a spur gear and a small pinion connected to a flexible shaft. The amount of power transmitted being very small and resistance being reduced to a minimum by ball bearings, the installation of a complicated and heavy worm gear device could be dispensed with. The pinion is held on the spurwheel by a torsional spring, and may be lifted to cut off the transmission gear when no tests are being made.

The wheel tires are of standard tread. The error originating

from the non-preventable tire wear can be compensated by replacing the spurwheel mounted on the axle with others having a smaller number of teeth. Provisions are made for spare gears for each decrease of about 10 mm. in car wheel diameter.

There are two groups of recording pens, each arranged in one line perpendicular to the path of the paper. The measurements which can be recorded are given below:

GROUP I.

Speed in kilometers per hour.
Inertia force in kilograms per ton; positive and negative.
Buffing reaction in kilograms.
Pulling reaction in kilograms.
Drawbar horsepower.
Work to overcome forces due to inertia, in meter-kilograms.
Work on the drawbar in meter-kilograms.
1.3 or 6 seconds, magnet contacts.
1 minute contacts.
Distance marks, kilometers, stations, etc.
Indicated horsepower, high pressure cylinder, front.
Indicated horsepower, high pressure cylinder, back.
Indicated horsepower, low pressure cylinder, front.
Indicated horsepower, low pressure cylinder, back.

GROUP II.

Length of stop, meters.
1.3 or 6 seconds, magnet contacts.
Air pressure, auxiliary reservoir.
Air pressure, train line.
Air pressure, brake cylinder.
Radial force on brake shoe.
Tangential force on brake shoe.
Wind pressure.

There are eight other pens for the different zero lines in the first group, making 30 pens in all.

In order to meet all the requirements for tests with electric locomotives a complete set of electric measuring instruments has been installed on a board on the back partition of the testing room. This apparatus, to suit three-phase and single-phase alternating current, consists of a voltmeter, an ammeter and two wattmeters, recording in straight line ordinates by means of a sparking device. The paper in this apparatus is moved at the same rate of speed as that on the recording table, thus permitting an easy and quick comparison of the data recorded on the two sheets.

FAILURE OF FUSIBLE TIN BOILER PLUGS

An investigation into the failure and deterioration of fusible tin boiler plugs in service has recently been conducted by G. K. Burgess, physicist, and P. D. Mercia, assistant physicist, of the United States Bureau of Standards. In some cases such plugs have failed to melt and so give warning of dangerous boiler conditions, and investigation has shown that the tin filling in these cases had become oxidized, the tin oxide having a melting point above 2,900 deg. F.

One pronounced and dangerous type of deterioration is the oxidation of the tin along the grain boundaries, by which is formed a network of oxide throughout the tin. The plugs showing deterioration of this type all came from the same manufacturer and contained zinc in amounts varying from 0.3 per cent to 4.0 per cent. It is shown that this type of oxidation is due to the presence of the zinc. The latter metal is not soluble in the solid state in tin, and when a tin with small amounts of zinc is heated as in a boiler to about 340 deg. F. the zinc coalesces as a network enveloping the tin crystals or grains. The boiler water, particularly if it contains alkali, will attack the zinc, eating its way into the alloy along the zinc network, and finally form the oxide network described.

Lead and zinc are found to be the principal impurities in tin plug fillings, and since all failed plugs contained these or other impurities the conclusion is reached that if these impurities are eliminated by strict specifications and inspection, which will allow only admittedly superior qualities of tin, the danger of failures of these plugs will no longer exist.

UNIFLOW CYLINDER FOR LOCOMOTIVES

A number of uniflow engines have been built in this country within the last few years, all of them based on the design developed by Prof. Stumpf of Charlottenberg College, Berlin, Germany. These engines, although showing a phenomenal increase in economy over the old four-valve type, have several inherent defects that have made American engineers slow to adopt them. Among these defects can be mentioned the increased length of cylinders, the use of the heavy block piston and, in the case of a condensing engine, the danger of over compression when the engine loses its vacuum. The first two faults have entirely prevented the consideration of this type of engine for locomotive service.

With the purpose of removing these defects and producing a uniflow engine that would be adaptable to locomotive service, the design shown in the sketch was developed by Prof. H. A. Stringfellow, Mechanics Institute, Rochester, N. Y., and E. W. Templin, assistant chief engineer, Selden Motor Vehicle Company. Although this design is primarily intended for locomotive use, it is suitable for stationary service and any type of admission valve may be substituted for that shown.

The sketch shows a longitudinal and cross section of the cylinder. Instead of using the long block piston to open and cover the exhaust ports, a blank sleeve is used, the length of

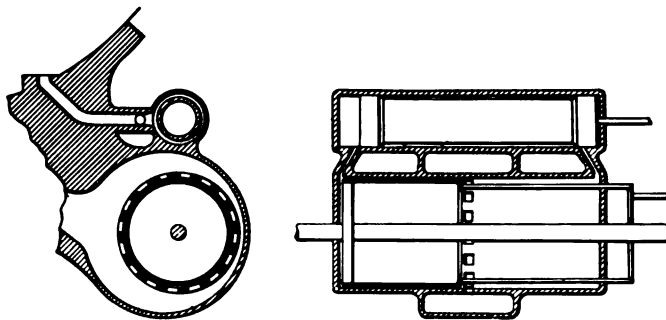

Proposed Design of Uniflow Cylinder for Locomotives

this sleeve being equal to one-half the stroke less the width of the exhaust port. The outside of this sleeve is provided with packing rings to make it steam-tight in the cylinder and reduce the sliding surface. The piston travels within the sleeve, both traveling in the same direction, and as the speed of the sleeve is approximately one-half the speed of the piston, the latter never runs outside of the sleeve. The sleeve may be driven from an eccentric, or by a rod, from any portion of any standard valve gear that will give the desired speed and motion. The sketch shows the use of two rods connected by a yoke outside the cylinder, as the means of transmitting motion to the sleeve. As it travels in the same direction as the piston, the steam pressure acting on what little end area is exposed is almost sufficient to drive it, thus relieving the valve gear from any great increase in work.

The exhaust port is placed at the middle of the stroke and not at the end as in present engines of the uniflow type. Because of this location and the use of the sleeve, this engine will show a later point of release than the usual uniflow engine, a release as late as 92 per cent. of the stroke being easily attainable. The cylinder is also more completely freed of the expanded steam, thus materially reducing the amount of clearance required. Any point of release from 92 per cent to 100 per cent may be obtained by varying the amount of lead the piston is given over the sleeve. When the sleeve is set as shown in the sketch so that the piston has no lead the engine may be reversed without moving the sleeve, but if lead is given to the piston the sleeve must be moved back a distance equal to twice this lead in reversing. This can be done by attaching the sleeve operating rod to a block in a link on the combination lever at the point

from which the sleeve is driven, and raising or lowering this block, as the case may be, by a suitable connection from the reach rod. The amount of release can be changed by simply setting the sleeve as a slide valve is set. The most economical point of release can only be determined by experiment.

SOUTHERN STEAM TENDER LOCOMOTIVE

BY HUGH G. BOUTELL

About 1863 Archibald Sturrock of the Great Northern Railway of England brought out a class of six-coupled goods locomotives with what he called a "steam tender." The tender was really a small locomotive with cylinders 12 in. by 17 in., and the weight with an average amount of fuel and water was about 37 tons. Steam was taken from the boiler of the main engine, which was larger than usual, and the exhaust, after passing through a heater in the tank, escaped to the atmosphere. The writer has never seen an accurate report of the performance of these engines, but it is understood that they showed great hauling capacity as compared with the ordinary freight engines in use at that time. However, as the tender, like the main engine, was inside-connected, it must have been difficult to make running repairs, and the working parts must have picked up a great deal of dirt from the locomotive and roadbed.

The Erie triplex locomotive recently built by the Baldwin

to lubricate the cylinders, but when a heavy grade is reached it may be opened to any desired amount. The exhaust passes to the atmosphere through the vertical pipe at the rear of the tank.

This engine is regarded only as an experiment, but its service so far is understood to have been entirely satisfactory and the construction of a similar machine, using the running gear of small consolidation locomotive, is under consideration.

The principal dimensions of the engine now in service are as follows:

	Main engine	Steam tender
Cylinders	27 in. by 30 in.	19 in. by 24 in.
Drivers, diameter.....	63 in.	54 in.
Weight on drivers.....	215,700 lb.	124,000 lb.
Total weight.....	272,940 lb.	152,700 lb.
Steam pressure.....	175 lb.	
Water capacity of tank.....		8,000 gal.

SOUTHERN PACIFIC SIX-VOLT ELECTRIC HEADLIGHT EQUIPMENT

BY A. H. BABCOCK

Consulting Electrical Engineer, Southern Pacific Company, San Francisco, Cal.

About a year and a half ago the Pacific System of the Southern Pacific Company replaced all its acetylene headlights with incandescent lamps of the automobile headlight type, but of larger size. The idea of automobile lighting was carried throughout the entire installation, even to the fittings employed in the

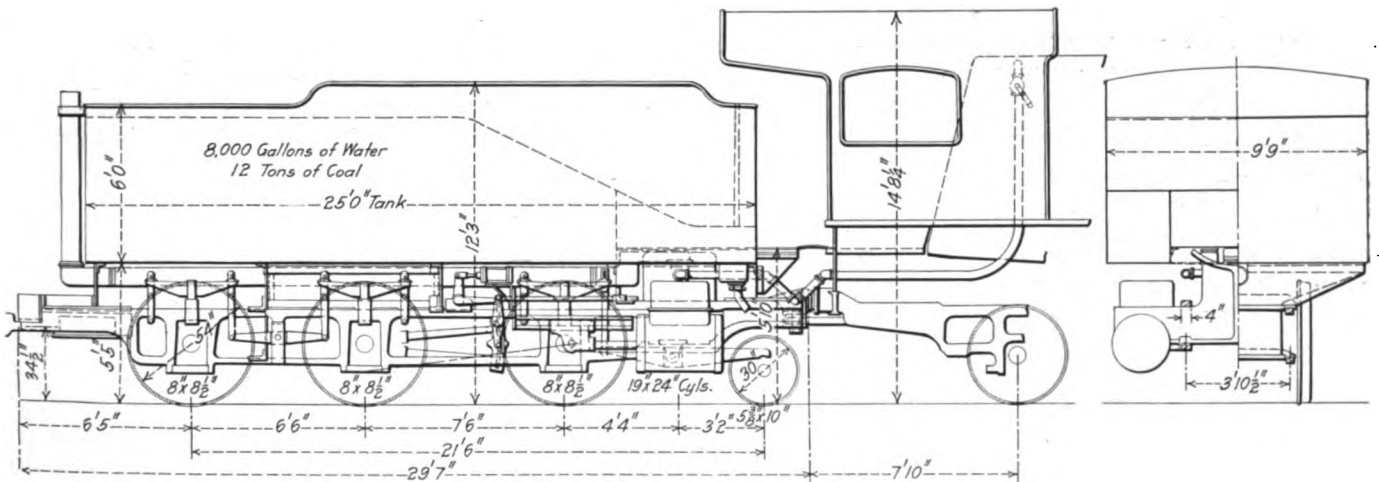

Arrangement of Mikado Type Tank on Running Gear of an Old Mogul

Locomotive Works may be regarded as a direct development from these early English engines, but still more recently the Southern Railway has designed an auxiliary tender that embodies exactly the same ideas as Sturrock's engines of the '60's. The arrangement consists of a steam tender applied to a Mikado type freight locomotive. The engines of this class had shown themselves to be such free steamers that the management concluded that two more cylinders could be supplied, at least for short periods. There are many conditions which may cause a train to stall when there is ample steam to keep it moving. Anything that will cause slipping on heavy grades may do so when there is not only steam but ample cylinder power as well. It is in such situations as this that the steam tender comes into play by increasing both the cylinder power and the adhesion. It really acts as a helper, but has the advantage of being on hand whenever it is needed.

A general conception of the construction of the machine may be obtained from the drawing. The boiler was removed from a small Rogers mogul locomotive and the tank of the Mikado engine placed on the frames, a few alterations having first been made in the tank to enable it to fit over the cylinder saddle. Steam is supplied to the tank cylinders through a flexible pipe connection by an independent throttle valve in the cab. Under normal running conditions this valve is opened merely enough

to take the place of the old smoking torch. One of the illustrations shows the type of automobile light fittings that in practice has been found satisfactory, except that under extreme summer desert temperature combined with high boiler temperatures, fittings

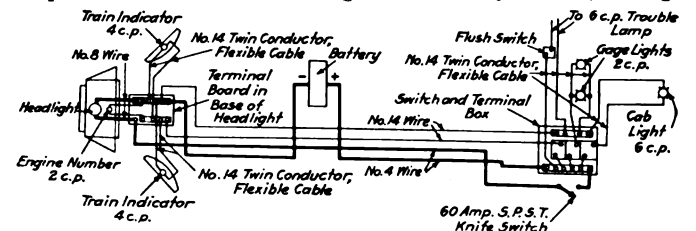

Wiring Diagram for Six-Volt Electric Headlight and Cab Lights

that are made of moulded rubber, or its equivalent, have softened. These are now being replaced with vitrified fittings.

In placing the lamps, particularly those in the cab, the principle followed has been to direct the necessary amount of light upon the spot where it is needed and to cut off all extraneous light, with the result that very small lamps give entirely satisfactory illumination and the sensitiveness of the engine crew's eyes is not diminished unnecessarily.

There are now 900 of these headlights in service and their

performance has been remarkable. The old acetylene or arc headlight reflector can be used by simply covering the openings.

flickering or jumping of the light, as is the ordinary experience with the arc headlight; and, furthermore, while the arc lamp has a mean spherical candle-power intensity of from 800 to 900 candles, according to conditions of the lamp and length of arc, its beam candle-power, with the same reflector is only 165,000.

Certain manufacturers of 32-volt arc headlight outfits are using 32-volt incandescent lamps, burned up to 37 volts, in the same reflectors in the hope of securing equal illumination by forcing the candle-power. On account of the necessity of the longer filament in the 32-volt lamp, this hope cannot be realized; in fact, tests show that even under these conditions the beam candle-power is less than one-half that of the six-volt lamp. Furthermore, the steam consumption of the turbo generators designed for arc headlight purposes is from 250 to 450 lb. per hour, while that of the most recent six-volt turbo generator for cab lighting is less than 50 lb. of steam per hour, and the cost of installation is slightly in favor of the six-volt outfit.

The portable trouble lamp was hung convenient to the engineman's head and by it he read his train orders, until it became evident that the portable light was also convenient around automobiles, of which our enginemen seem to have many. In fact, the practical results indicate that they found the trouble lamps more useful in the automobiles than in the engine, with the result that the trouble lamp is now being replaced with a fixed lamp over the engineman's head with a switch convenient to his head.

For the reason that these installations were somewhat rushed, owing to legal requirements, there was not sufficient time to develop a suitable electric generator, and it was necessary to use a battery, with stationary charging stations at the locomotive turning points, where the locomotives leave their exhausted

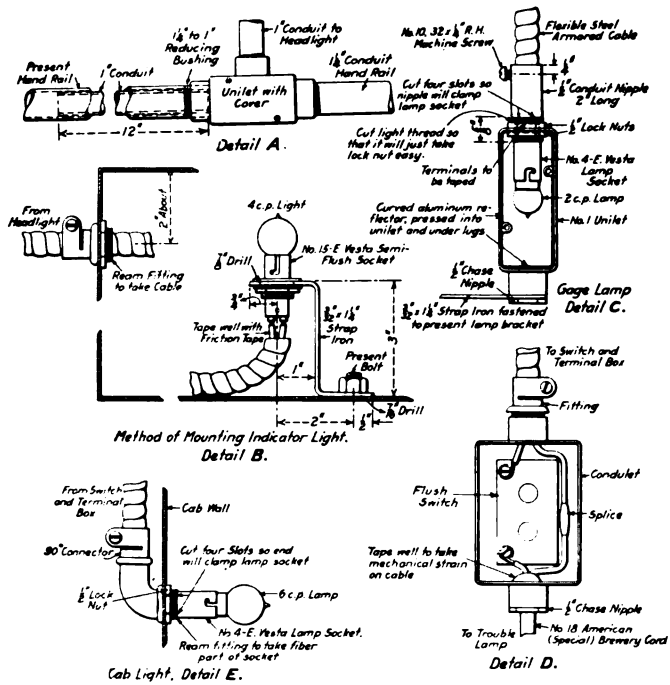

Details of Automobile Fittings Used in Southern Pacific Electric Headlight Installation

A new opening should be cut in the vertex of the reflector and the incandescent lamp, with its focusing device, inserted from

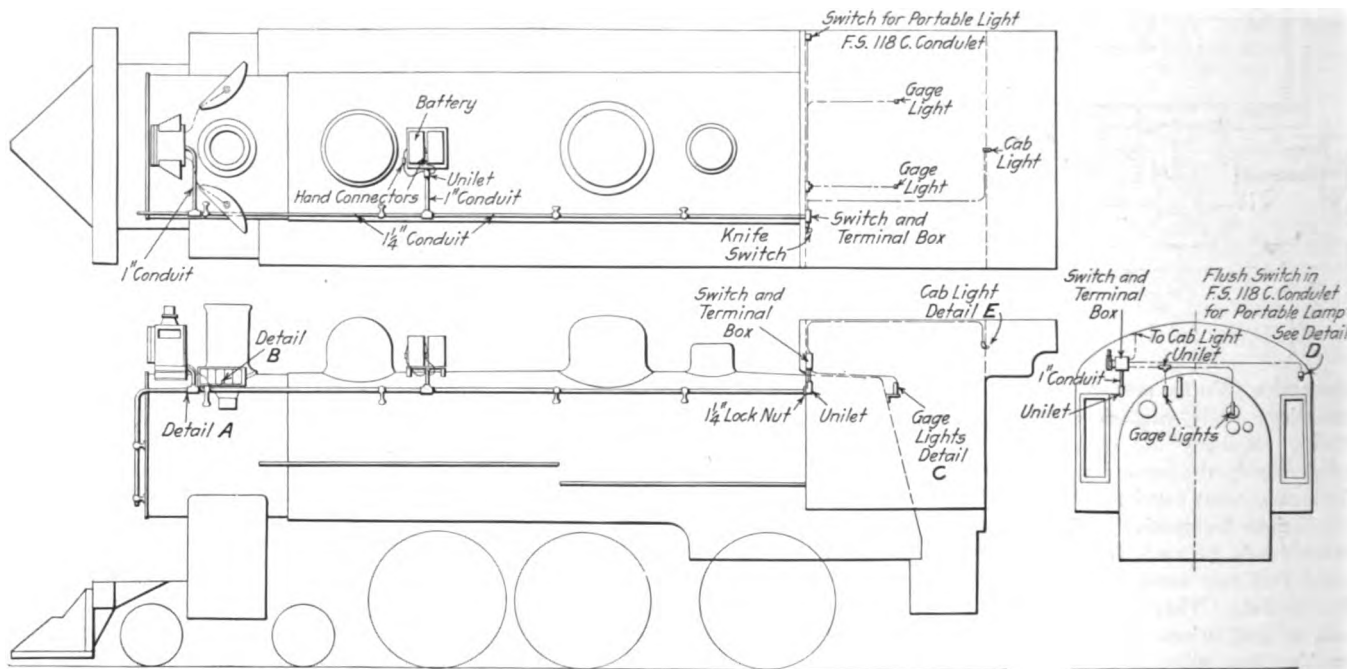

General Arrangement of Six-Volt Electric Headlight Installation, Southern Pacific

the rear. Lamps for six-volt circuits, especially in the sizes used for headlight purposes (108 watts) have filaments very strong and heavy, consequently they can be wound into an exceedingly small cylinder not more than 1/8 in. in diameter by 1/8 in. long. This can be placed very accurately in the focus of the reflector, and the result is a concentrated beam of light of very great penetration, the beam candle-power measuring approximately 1,046,000, while the mean spherical candle-power of the lamp itself is only 140. On the other hand, if a wide beam of less power is needed, as for example on crooked track in the mountains, an adjustment of the focus brings about this result. There is no

batteries and take full batteries, just as they take their supplies of sand, lubricant and water.

AMERICAN STEEL TO GREAT BRITAIN.—Great Britain's imports of blooms, billets and slabs from the United States in August were 44,059 gross tons, against 471 tons in August, 1914. For the eight months to Sept. 1, 1915, they were 252,330 tons, compared with only 21,357 tons to Sept. 1, 1914. For the 13 months of the war, from Aug. 1, 1914, to Sept. 1, 1915, total imports from the United States were 261,672 tons, against 24,230 tons for the same period a year previous.—*The Iron Age*.

THE MIKADO VS. THE CONSOLIDATION

A Study to Determine the Economical Distribution of Power from a Net Revenue Standpoint

BY N. D. BALLANTINE

Assistant to Chief Operating Officer, Rock Island Lines

For the purpose of determining the relative merits of the Mikado and Consolidation locomotives on certain divisions of the Rock Island, a study was made under practical operating conditions, which showed, among other things, where a given number of locomotives of each type could be used to the best advantage from a net operating revenue standpoint. The month selected for the study was during a period of heaviest traffic, when there was a constant demand for power; the data was tabulated subsequent to the performance, and none of the division officials knew that such a study was to be made, hence the freedom from chances for preferential handling of either class of power. The records made currently were tabulated and carefully checked against train sheets, train registers, roundhouse registers, work sheets and fuel tickets. Every practical means was used to secure correct information. There are some apparent discrepancies with respect to the maintenance features, which it is thought were due to the fact that the Mikado locomotives were practically new, there being no question about the expense for heavy repairs made during such a limited time not being as correct a basis as it would be if a year's figures were used. These being the only figures available, they were used, and as they are clearly set out, one can accept or ignore that portion of the study if desired.

The study covers the performance in freight service, other than

show the items in the *direction of traffic* for slow freights; fast freights; combined slow and fast freights; and slow and fast freights on the round-trip basis, the latter figures, for the sake of brevity, being used in this article. None of the divisions on which these locomotives were used have a very large percentage of their traffic of a low grade which will admit being held any considerable length of time for tonnage, the controlling business being made up of merchandise, live stock, packing-house products and perishable freight, which fact makes a study of this nature all the more necessary. The detail information as shown permits a variety of deductions to be drawn directly or by combinations, many of which will be apparent on inspection; a few of them will be pointed out, however.

Table A shows the locomotive utilization, and it is interesting to note the variation in the mechanical department detention on the various divisions. On three divisions it was less for the Mikados, and on the other division, where most of the Mikados were located, it was considerably more, averaging for all divisions 45 minutes more than for the Consolidations. The terminal delay varied from 3 hrs. 11 min. to 7 hrs. 34 min., depending on local conditions; but it is interesting to note that on the division where the greatest volume of traffic was moving, the terminal delay was the lowest for both classes of engines. The time between terminals varied from 7 hrs. 6 min. to 10 hrs. 6

TABLE A—LOCOMOTIVE UTILIZATION, OR A TIME STUDY SHOWING DAILY AND OTHER AVERAGES

	Division A		Division B		Division C		Division D		Averages	
	Mik.	Cons.	Mik.	Cons.	Mik.	Cons.	Mik.	Cons.	Mik.	Cons.
Time under mechanical department (hr. and min.).....	9-11	9-18	8-54	9-6	10-39	10-43	9-42	8-15	9-53	9-8
Time at terminals (hr. and min.).....	6-42	5-18	7-22	7-18	3-25	3-11	7-12	7-34	5-37	6-8
Time between terminals (hr. and min.).....	8-7	9-24	7-44	7-36	9-56	10-6	7-6	8-11	8-30	8-44
Actually running, hr. and min.	5-5	6-6	5-47	5-46	6-25	6-51	5-30	6-23	5-56	6-25
Meeting trains, hr. and min.	1-31	1-46	1-6	0-55	1-30	1-25	0-58	0-56	1-16	1-9
Station work, hr. and min.	0-21	0-37	0-38	0-34	1-6	0-49	0-23	0-33	0-40	0-38
Track conditions, hr. and min.	0-3	0-1	0-2	0-1	0-1	...
Block signals, hr. and min.	0-1	0-1	0-6	0-4	0-3	0-2
Engine failures, hr. and min.	0-1	...	0-2	0-5	0-2	0-3	0-2	0-1
Car failures, hr. and min.	0-9	0-3	0-5	0-4	0-11	0-4	0-1	0-3	0-7	0-3
Miscellaneous, hr. and min.	0-56	0-50	0-4	0-12	0-38	0-53	0-12	0-12	0-25	0-26
Total time—hours	24	24	24	24	24	24	24	24	24	24
Speed between terminals (m. p. h.).....	10.7	11	15.9	18	13.6	14.6	14.5	14.5	14	14.7
Speed actually running (m. p. h.).....	17.1	17.1	21.2	23.6	21.2	21.7	18.7	18.6	20.2	20
Delays per 100-train miles, meeting trains (hr. and min.).....	1-44	1-43	0-53	0-42	1-11	0-57	0-57	0-79	1-36	0-53
Delays per 100-train miles, station work (min.).....	24	34	29	25	45	33	18	27	33	29
Gross ton-miles per day.....	130800	121669	174109	123997	273780	223980	151373	130193	205600	154600
Gross ton-miles per hour (actually running).....	25700	20077	30010	21452	42644	32698	27522	19739	34730	24081

local or way freights and work trains, on four divisions for 31 days of the same month, of 27 Mikado superheater locomotives of 57,000-lb. tractive effort, making 71,000 miles, and 59 Consolidation saturated steam locomotives of 39,000-lb. tractive effort, making 116,275 miles. A total of 262,815,000 gross ton miles was handled, of which the Mikados were responsible for 48 per cent.

No attempt was made to include or compare the expense of maintenance of way and structures, general expenses, supervision, station service, yard service, train supplies, loss and damage and a number of other factors in operating expenses, a variation of which would not be appreciably affected by the class of power handling the traffic. The items included do not purport to represent the total actual cost of handling traffic, but it is thought they include the essential variable items that can practically be located and that are of sufficient importance to justify their inclusion in a study which does not contemplate a degree of refinement in costs to produce figures accurate to the fifth or sixth decimal part of a cent.

In tabulating the data for our own use, it was separated to

min., averaging for all Mikados but 14 min. less per day than for all Consolidations. The actual running time varied from 5 hrs. 5 min. to 6 hrs. 51 min., averaging for all Mikados 29 min. less per day than for the Consolidations. The miles per hour between terminals varied from 10.7 to 18, averaging 14 for the Mikados, or 0.7 m. p. h. less than the Consolidations. The miles per hour when actually running varied from 17.1 to 23.6, averaging 20.2 for the Mikados, or 0.2 m. p. h. more than the Consolidations. The delays per 100 miles, meeting trains, varied from 42 min. for the Consolidations to 1 hr. 44 min. for the Mikados, averaging 1 hr. 36 min. for the Mikados, or 43 min. (equal to 81 per cent) more than for the Consolidations. This fact may or may not be due to longer trains, but as the 43 min. increase is more than 8 per cent of the total time between terminals for the Mikados, its significance should be studied more in detail. The average delay per 100 miles doing station work only varied 4 minutes.

The gross ton-miles per day varied for the Consolidations from 121,669 to 223,980, or 184 per cent, and for the Mikados from 130,800 to 273,780, or 210 per cent, while the average for

all Consolidations was 154,600 and for the Mikados 205,600, or 33 per cent more than the Consolidations. It should be recalled that the Mikados have 46 per cent higher tractive effort. The gross ton-miles per hour when actually running varied for the Consolidations from 20,077 to 32,698, or 63 per cent, and for the Mikados from 25,700 to 42,644, or 66 per cent, while the average for all Consolidations was 24,081, and for the Mikados 34,730, or 44 per cent more than the Consolidations. It should be particularly noted that for the time the engines were *actually running* the increase in ton-miles handled by the Mikados was within 2 per cent of the increase in its tractive effort over the Consolidations, but by referring to the first part of this paragraph it will be noted that when compared on a *daily performance*

tives, had a condition which enabled it to obtain a higher efficiency with the Mikados than on any other division, and this regardless of the fact that it also obtained a higher loading efficiency with the Consolidation locomotives than on any other division. It should be borne in mind that the figures given are for round-trips and an analysis of the figures covering only the *direction of traffic* may produce somewhat different results. In reality, it is *directional* figures which are of the most vital moment to the study, particularly where the traffic is unbalanced to an appreciable degree, high loading efficiency in the direction of traffic being a most significant figure to ascertain.

Table C gives the costs in cents per thousand gross ton-miles for the different items considered in this study. Interest at 6

TABLE B—PHYSICAL DATA

	Division A		Division B		Division C		Division D		All Divisions	
	Mikados	Consols	Mikados	Consols	Mikados	Consols	Mikados	Consols	Mikados	Consols
Number of engines	2	13	4	9	14	15	7	22	27	59
Engine days	50	75	125	111	250	251	170	47	595	908
Locomotive miles	4358	7814	15402	15210	33762	37163	17478	56088	71000	116275
Locomotive miles per day	87	104	123	137	135	148	103	119	119	128
Gross ton miles	6544.5	9125.2	21763.7	13763.7	6844.5	56219.2	25633.4	61320.9	122386	140429
Gross tons per train mile	1500	1170	1413	904.2	2015	1470	1466.6	1093.3	1723	1207
Loading efficiency (per cent)	51.3	64.2	76.4	72	62	68	62.2	68.7	67	68.5
Number of trains	43	80	123	125	216	229	147	476	529	910
Average distance run (miles)	102	98	125	122	156	162	119	118	134	128

basis, the ton-miles handled is not within 13 per cent of the increase in tractive effort.

Table B indicates by divisions the number of locomotives, locomotive days, mileage and average miles per day, gross ton-miles and gross tons per train-mile, and loading efficiency. It will be noticed from the gross ton-miles produced that there is quite a difference in the volume of business handled on the various divisions; there was also a difference in the class of the traffic. It will be noted that on each division the Mikados made from 13 to 17 miles less per day than the Consolidations, the percentage for all Mikados during the entire period being 7 per cent less. It should also be noted that the division upon which both classes of locomotives made the highest mileage per day was that upon which the length of the average trip was the greatest. The distance between terminals generally has a very

per cent has been figured on the locomotives and cabooses, and depreciation at 5 per cent for the locomotives and 6 per cent for the cabooses. These figures per thousand gross ton-miles vary from 3.1 cents for the Consolidations on Division C, to 6.8 cents for the Mikados on Division D; for all Mikados it amounts to 4.8 cents, or about 12 per cent of the costs enumerated, while for all Consolidations it amounts to 4 cents, or 8.3 per cent of the costs enumerated. Special mention is made of this point for the reason that for certain purposes it is essential to include such items, while for others they probably should not be included; for example, if the question is one dependent on the type of new locomotives to be purchased, or the question of additional locomotives, it manifestly should be included; if, however, it is a question of once having the equipment and of determining the best location for its utilization, interest and depreciation will accrue

TABLE C—PRINCIPAL VARIABLE COSTS PER THOUSAND GROSS TON-MILES IN CENTS

	Division A				Division B				Division C				Division D				All Div.			
	Mik.	Con.	Inc. or Dec.	Amt. Percent	Mik.	Con.	Inc. or Dec.	Amt. Percent	Mik.	Con.	Inc. or Dec.	Amt. Percent	Mik.	Con.	Inc. or Dec.	Amt. Percent	Mik.	Con.	Inc. or Dec.	Amt. Percent
Coal	20.3	22.5	-22	9.8	15.4	20.3	-4.9	24.1	11.4	15.6	-4.2	26.9	13.6	18.0	-4.4	24.5	13.0	17.6	-4.6	26.1
Wages, train and engine crew	13.5	16.9	-3.4	20.1	13.2	20.9	-7.7	36.5	9.8	12.5	-2.7	21.6	13.4	17.4	-4.0	23.0	11.4	15.8	-4.4	27.8
Roundhouse charges	4.0	4.0	3.2	3.4	-0.2	5.9	3.0	2.7	+3	11.1	1.5	1.9	-0.4	21.1	
Water	1.5	1.7	-2	11.8	1.3	1.5	-2	13.3	1.0	1.4	-4	28.6	1.0	1.3	-3	23.1	
Lub. oils and waste
Running repairs	6.6	2.4	+4.2	143.3	4.0	2.5	+1.5	60.0	2.2	2.1	+1	4.8	5.9	3.5	+2.4	68.6	3.5	2.8	+7	25.0
Classified repairs	2.0	3.6	-1.6	44.4	2.1	4.7	-2.6	55.3	1.9	4.0	-2.1	52.7	2.6	4.5	-1.9	42.2	2.1	4.2	-2.1	50.0
Int. on locomotives at 6 per cent	3.3	2.4	+9	37.5	2.5	2.3	+2	8.7	2.0	1.6	+4	25.0	3.6	2.5	+1.1	44.0	2.5	2.1	+4	19.0
Int. on cabooses at 6 per cent
Depreciation loco. at 5 per cent	2.8	2.0	+8	40.0	2.1	1.9	+2	10.5	1.6	1.3	+3	23.1	3.0	2.0	+1.0	50.0	2.1	1.7	+4	23.5
Depreciation cabooses at 6 per cent
Totals	54.7	56.0	-1.3	2.3	44.7	58.3	-13.6	23.3	31.0	39.9	-8.9	22.3	46.6	52.7	-6.1	11.6	38.0	48.3	-10.3	21.3

important bearing upon the miles per day locomotives make and that it increases with the distance between terminals is to be expected, as it decreases the roundhouse handling and yard terminal delays per 100 miles; hence, the importance of running locomotives through terminals or making turn-arounds if the power is in condition to permit this being done without unduly increasing engine failures.

The gross tons per train-mile for the Mikados varied from 28 to 56 per cent more than that handled by the Consolidations; the average for all divisions is 43 per cent, or about 3 per cent less than the difference in tractive effort, indicating that, as a whole, there was less loading efficiency obtained with Mikados than with the Consolidations.

This is reflected more clearly in the loading efficiency column, which shows that Division B, while having but four locomo-

regardless, and can as well be omitted for purpose of an immediate comparison. It will be noted the costs for the variables listed run from 31 cents for the Mikados on Division C to 54.7 cents on Division A, and for the Consolidations from 39.9 cents on Division C to 58.3 cents on Division B, while for all Mikados it was 38 cents as compared with 48.3 cents for the Consolidations.

A glance at Table A might cause one to feel that the proper place to put the Mikados would be where they would produce the most gross ton-miles per day or hour, in which event it would point to Division C, as on this division they produced 273,790 gross ton-miles per day, or 42,644 gross ton-miles per hour when actually running. What we are trying to determine, however, is whether it is more economical to keep the Mikado on a particular division as opposed to another division. Let us compare

Divisions B and C. By referring to Table C and Division C it is noted the cost per 1,000 gross ton-miles is 8.9 cents less for the Mikados than for Consolidations, and as the Mikados produce 273,790 gross ton-miles per day, this is equivalent to their saving \$24.36 per day, while by referring to Division B, it will be noted the Mikados save 13.6 cents per 1,000 gross ton-miles, which with the 174,109 gross ton-miles they produce per day, makes a saving of \$23.68, a difference of only 68 cents in favor of Division C. As previously referred to, however, the maintenance feature was known to be a little uncertain, and inspection indicates the running and classified repairs on Division B was 6.1 cents as against 4.1 cents on Division C, or nearly 50 per cent more. With such a wide difference in this item, it would not be unfair to average the two, or eliminate the feature; in either of which events, it will indicate that the greatest saving can be effected on Division B.

A knowledge of local conditions is, of course, an advantage in making such an analysis, as in this particular instance it is known that with the volume of traffic moving on Division B, and the necessity for protecting local work, it would not be economical to place any more Mikados on that division under present traffic conditions. The above analysis indicates, in this specific case, economy in operation to use a Mikado locomotive on a division where it will not produce within 65 per cent of the ton-miles which it produces on another division, a condition which will doubtless appeal to many as an anomaly.

In this connection there might also be pointed out the relation existing between handling tonnage with large versus small power when the train-mile unit is used. It is frequently considered by some that increasing the size of power and being able to utilize it as efficiently as the smaller power, thus reducing train-miles, will bring about a reduction in expenses equivalent to the cost of a train-mile saved; but that this is a fallacy, can, I think, easily be pointed out from the data contained in the above tables. For example, the costs on Division A per 1,000 gross ton-miles for the Mikados were 54.7 cents, the average tons per train were 1,500, therefore the cost per train-mile was 82 cents. The cost for the Consolidations per 1,000 gross ton-miles was 56 cents, the average tons per train was 1,170, therefore the cost per train-mile was 65.5 cents. Here there was an increase of 330 tons in tons per train-mile with an increase of 16.5 cents in the cost per train-mile. Inasmuch as the Mikado handles 330 tons more than the Consolidation it will take 3.55 Mikado trains to save one Consolidation train-mile. Inasmuch as each Mikado train costs 16½ cents more per train-mile than the Consolidation the product of 16½ x 3.55 equals 58.5 cents, or 7 cents less than the cost for a Consolidation train-mile. In other words, the real saving per train-mile is 7 cents instead of 65½ cents as might be roughly estimated.

When such a narrow margin of saving exists as shown in this case, it is worth while investigating the matter very carefully, considering another factor, namely, the interest on "additions and betterments" which were necessary to especially provide for the Mikados' repairs, housing, turning and their safe movement over the road. The feature of "additions and betterments" is one which should always be taken into account when considering change from small to large units; after they have once been made, as there is no way to get away from the interest charge thereon, it is of course, unnecessary to consider them if the two divisions were to be compared have the necessary facilities; if, however, one division has the facilities and the question arises about transferring some of its power to another division which is not provided with the facilities, then in order to determine the propriety of switching a given amount of power to such division the determination should be made upon the new division's economy, including interest on "additions and betterments," versus the equipped division's economy, excluding this interest.

Consideration of the effect upon maintenance of way and structures due to the use of the larger locomotives has been purposely avoided, for the reason that it is still a moot question among engineers. The above study should indicate that a variety of angles exist from which to approach this subject, as well as

the importance of having the detail information such as is set forth currently prepared. Unless it is prepared currently, much of it is impractical to secure and thus precludes a definite knowledge of many vital items. Also, in making any such study the actual traffic conditions must be carefully considered.

LOCOMOTIVE COAL CONSUMPTION*

BY LAWRENCE W. WALLACE

Professor of Railway and Industrial Department, Purdue University

Last spring the department of Railroad and Industrial Management of Purdue University conducted certain road tests of locomotives to determine the relative efficiency of certain coals and methods of firing for the Monon. They were conducted through the co-operation of H. C. May, superintendent of motive power, and his staff, and the representatives of the Railway Mechanical Engineering Department of Purdue University. The tests extended over a period of 30 days, through which period observations were taken by students specializing in railway me-

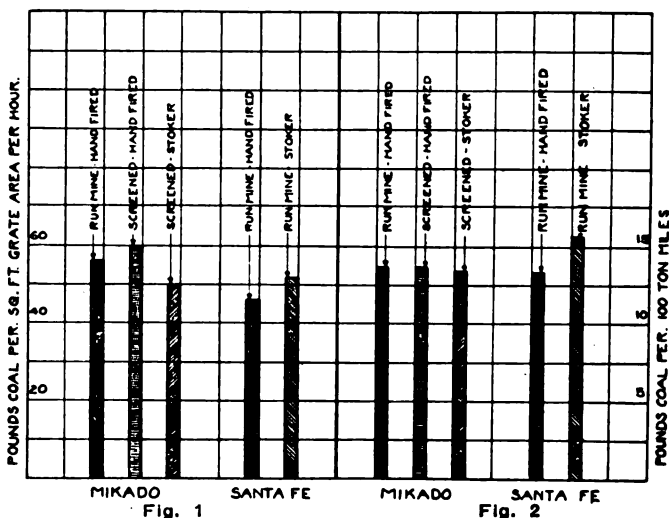

chanical engineering. They were designed to determine: The evaporative efficiency of the boiler of a Mikado and of a Santa Fe type locomotive, where screened and unscreened coal was used; and the evaporative efficiency of each of the two boilers when hand-fired and when stoker-fired, both screened and unscreened coal being used. Every precaution was taken to obtain accurate and reliable data. The tests were made between Lafayette, Ind., and Bloomington, a distance of 100 miles. The maximum grade was 2 per cent and the maximum curve 4 deg. For a considerable portion of the distance many curves and small grades prevailed. The locomotives were in fast freight service.

Locomotives.—Each of the Mikado and Santa Fe locomotives used were of the same respective class. The essential features of each are given in Table I. The locomotives were equipped

TABLE I.—PRINCIPAL DIMENSIONS OF THE LOCOMOTIVES TESTED

	Mikado	Santa Fe
Cylinders	28 in. by 30 in.	28 in. by 30 in.
Piston valves, diameter	14 in.	14 in.
Valve gear	Walschaert	Walschaert
Grate area	54.5 sq. ft.	70 sq. ft.
Heating surface, tubes	3,671 sq. ft.	4,485 sq. ft.
Heating surface, firebox	245.5 sq. ft.	282 sq. ft.
Heating surface, total	3,916.5 sq. ft.	4,767 sq. ft.
Tractive effort	53,900 lb.	66,700 lb.
Weight on drivers	218,000 lb.	278,500 lb.
Weight on leading truck	26,000 lb.	27,000 lb.
Weight on trailer	42,000 lb.	44,500 lb.
Total weight of engine	286,000 lb.	350,000 lb.
Weight of tender loaded	178,000 lb.	180,000 lb.

with Schmidt superheaters and were in good repair.

Coal.—The unscreened coal was the ordinary mine-run coal common to Southern Indiana. It contained from 50 to 60 per cent of slack. The screened coal was of the same grade as the

* Abstract of a paper presented at the October meeting of the St. Louis Railway Club.

mine-run, the only difference being that it was put through a 1¼-in. mesh screen before being placed upon the tender. It contained a very small percentage of slack. It is known as No. 4. Each coal was hand and stoker-fired on each type of locomotive. A Standard stoker was used.

Results.—The average results obtained from the complete series are tabulated in Table II, the values given being the average of three round trips in each case.

A study of the table will disclose that fairly uniform conditions of speed and tonnage were maintained for the several tests. On a number of trips, however, abnormal waiting on sidings was experienced, and it was necessary to double a hill on several occasions. But as such irregularities were about as frequent in one of the tests as another, the relative results were approximately the same, hence the results are truly indicative of the merits of each coal and each method of firing. It should be said in behalf of the stoker that as soon as it was applied and given a short trial, the locomotive to which it was applied was

would indicate, therefore, that if it is necessary to crowd a boiler to near its limit, there is a greater possibility of doing so by the use of a stoker than otherwise, as more mine run coal can be continuously supplied to the grate per hour by means of a stoker than by hand. The point at which the heavy firing becomes a wasteful process depends upon several factors, namely: The draft, grate area, amount of heating surface and its condition.

It is interesting to note that the relative position of the curves

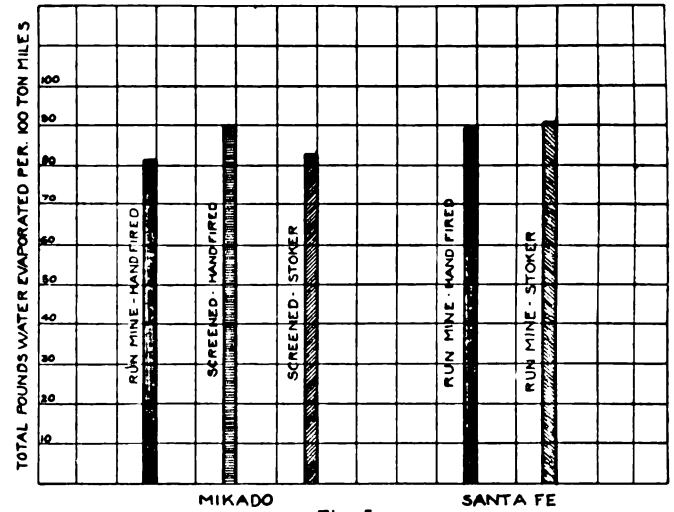
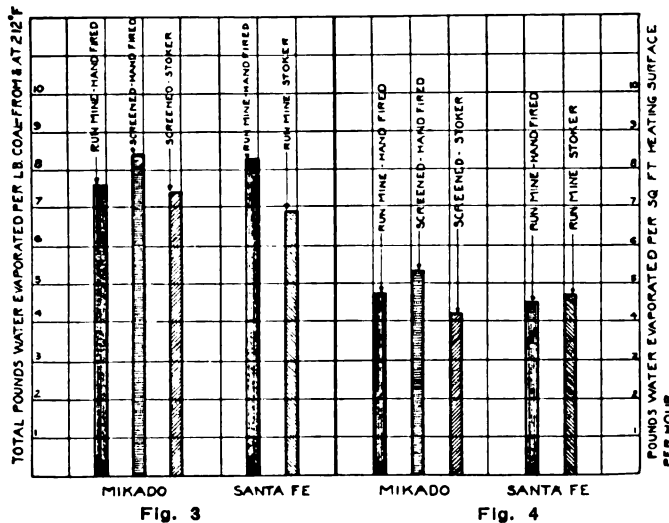

for the Mikado locomotive, Fig. 3, are the same as they were in Fig. 1. That is, the best results were obtained when screened coal was hand fired. Screened coal, hand fired, gave an evaporation of 8.4 lb. of water from and at 212 deg. per lb. of coal. Mine run hand fired gave an evaporation of 7.6 lb., a difference of 10 per cent in favor of screened coal; and screened coal, stoker fired, gave an evaporation of 7.4 lb. of water per lb. of coal, a difference of 13 per cent in favor of screened coal, hand fired, as compared with stoker firing. The mine run, hand fired, gave an evaporation of 8.3 lb. of water per lb. of coal on the Santa Fe and only 6.9 when stoker fired, or a difference in favor of hand firing of 16.8 per cent.

The results plotted for the Mikado locomotive in Fig. 4 clearly indicates that a greater amount of water was evaporated per square foot of heating surface per hour when screened coal was hand fired than for any other condition of the tests. With screened coal, hand fired, an evaporation of 11 per cent greater was obtained than with mine run, hand fired, and 21 per cent more than with screened coal, stoker fired. There was only a difference of 4 per cent in the rate of evaporation when mine

tested. This meant that the stoker was not fully adjusted in all respects. Again, the operator was required to fire a coal with which he had no previous experience. Bearing these things in mind, the performance of the stoker was very satisfactory.

Certain of the more important results have been plotted in order to make them more comprehensive. In Fig. 1 is plotted the pounds of coal fired per square foot of grate area per hour, for each of the several test conditions. This indicates the intensity of the rate of firing, which is a significant factor. It will be noted that with the Mikado a greater quantity of coal was

TABLE II.—AVERAGE RESULTS OF COAL TESTS, HAND AND STOKER-FIRED

Locomotive type	Kind of fuel	How fired	Total ton-miles	Speed M. P. H.	Steam		Total coal, lb.			Total water evaporated, lb.					
					B. P.	Temp.	Consumed	Per sq. ft. grate per hr.	Per 100 ton-mi.	Per lb. of coal	Per lb. of coal from and at 212 deg.		Per sq. ft. H. S. per hr.	Per sq. ft. grate per hr.	Per 100 ton-mi.
											XI	XII			
Mikado	Run of Mine	Hand	191,102	18.3	168.7	522	26,418	56	13.6	6.2	7.6	4.7	331.0	81.5	
Mikado	Screened	Hand	175,491	19.8	170.0	531	24,250	60	13.6	6.9	8.4	5.3	393.4	90.0	
Mikado	Screened	Stoker	180,123	19.2	168.5	533	24,200	50	13.4	6.2	7.4	4.2	303.0	62.8	
Santa Fe	Run of Mine	Hand	220,265	18.5	187.5	489	29,233	46.4	13.6	6.8	8.3	4.5	304.0	89.3	
Santa Fe	Run of Mine	Stoker	234,382	18.7	176.2	520	35,933	52.0	15.6	5.75	6.9	4.1	313.8	90.4	

burned per square foot of grate per hour when screened coal was hand fired than when mine run was so fired. Also that the smallest amount was burned when screened coal was stoker fired. With the Santa Fe locomotive a greater quantity of coal was burned when mine run coal was stoker fired.

On the basis of coal consumption per 100 ton-miles, as shown in Fig. 2, it is apparent that the amount of coal burned per 100 ton-miles was approximately the same for each of the three conditions indicated for the Mikado locomotive. But for the Santa Fe a greater quantity was consumed per 100 ton-miles when mine run coal was stoker fired than when hand fired. This

run coal was stoker fired and when hand fired.

Another measure of the relative merits of the coals used and firing methods employed is shown in Fig. 5, the unit of measurement being the total pounds of water evaporated per 100 ton-miles. Again, with the Mikado locomotive, screened coal, hand fired, gave the best results, there being an evaporation of 9.4 per cent more with screened coal, hand fired, than mine run, hand fired. Approximately the same results were obtained with mine run, hand fired, and screened, stoker fired. With the Santa Fe better results were obtained with the mine run, stoker fired, than hand fired. The amount in favor of stoker was very small.

CAR DEPARTMENT

CAR DERAILMENTS, CAUSES AND A REMEDY

BY H. M. PERRY

The derailment of cars, especially those of recent steel construction, is a matter to be seriously considered by both the operating and mechanical departments of the railways. The demand for greater carrying capacity and the increase in weight and speed of trains has forced the builders to substitute steel in place of wood in all classes of car equipment, either in the form of steel underframes or of all-steel construction. This produces a car frame that is absolutely rigid, so much so that a jack placed under one corner of a car will raise the whole end as square as though the jack were placed under the middle of the end. When such a car enters a curve where the outer rail is elevated 4 in. or more, and the approach is comparatively short, the weight on the forward end of the car is carried almost entirely by the outer forward side bearing, unless the clearance between the side bearings is sufficient to overcome the difference in the elevation of the rails. This is seldom the case, except perhaps on new equipment before the bolsters deflect or the center plates wear down and reduce the clearance between the bear-

side bearings are in contact, the outer rail being elevated 5 in. Now, when the load is suddenly changed from the position shown in Fig. 2 to that shown in Fig. 3, it relieves the load on the outer wheels and sometimes raises them off the rail, the car falling over on the inside of the curve. This is particularly the case with some refrigerator cars, when the load is hung from the roof, although many of the all-steel box cars, as well as some of the hopper cars, have met the same fate.

An illustration of the trouble caused by a high center of gravity with the side bearings placed at 60-in. centers and with over $\frac{3}{8}$ -in. clearance between them, together with an excessive elevation of the outer rail on a curve, may be had in an actual case of a refrigerator car loaded with meat hung from the roof, and running at a speed of 10 m. p. h. This car rolled over on the inside of the curve. The car was unloaded and set back on the track only to immediately tip over again. To hold it upright it was necessary to use guy lines until it was moved to a level track. Of course, this was an exceptional case and under abnormal conditions, but serves to show the tendency of cars to tip over when these conditions obtain.

Similar cases occurred on a western road which had 1,000 refrigerator cars, a very large number of which were derailed

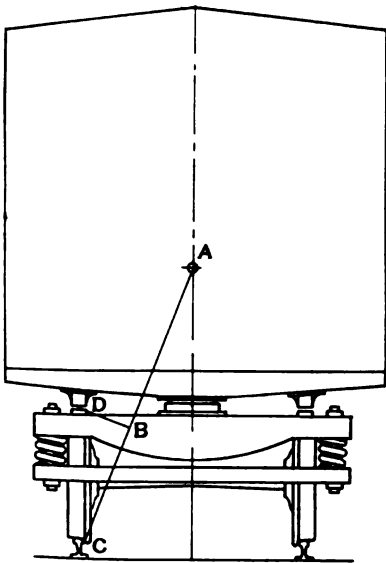

Fig. 1

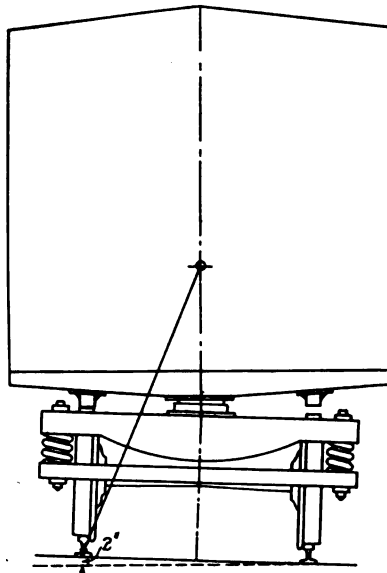

Fig. 2

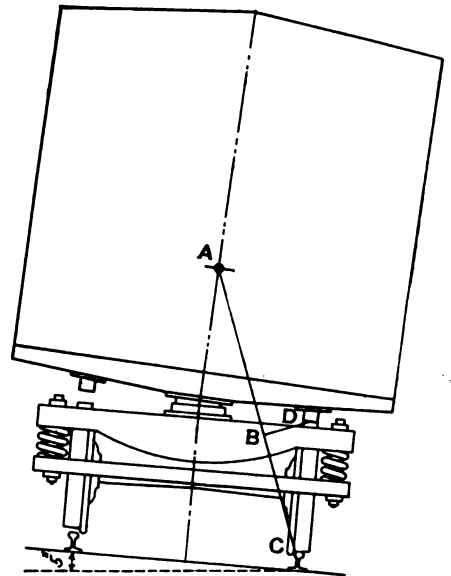

Fig. 3

ings. When rigid cast iron side bearings are used on these cars the friction between them is often greater than the reaction between the wheel flange and the rail, and as a result derailment occurs. The same condition will be found when such cars are leaving a curve; in this case the derailment almost always is caused by the leading outer wheel on the rear truck mounting the rail.

Another cause of many derailments is the position of the side bearings on the bolsters and excessive clearance between the bearings, especially where the car has a high center of gravity. Fig. 1 shows a car standing on a level track, the side bearings being placed at 60-in. centers with $\frac{3}{8}$ -in. clearance, and the center of gravity of the car being 6 ft. above the rail. Fig. 2 shows this car entering a curve, where the outer rail is elevated only 2 in., and with the outer side bearings in contact, the load being distributed between that point and the center plate. Fig. 3 shows the car on the curve, but tipped down so that the inner

under every possible condition and on almost every road over which they were operated. These cars had a high center of gravity, rigid side bearings, which were placed on 60-in. centers, and $\frac{3}{8}$ -in. clearance between the bearings. It seemed to make no difference whether these cars were loaded with meat hung from the roof or with merchandise; they simply left the track at every opportunity and apparently without any cause whatever. Later this same company purchased another lot of 1,000 cars, built to the same specifications, but provided with roller side bearings placed on 54-in. centers having only about $\frac{1}{4}$ -in. clearance. The road never had a case of derailment with this lot of cars, which looks like conclusive evidence that the side bearings prevented the derailment of these cars.

Another interesting case was that of a heavy express car built new at a railroad shop. This car had a rigid steel underframe and was mounted on the road's standard steel trucks. It was 42 ft. long over end sills, with a rather high center of grav-

ity, rigid side bearings were placed on 60-in. centers with a clearance of $\frac{3}{8}$ in. In order to limber up the car, it was sent out empty, and at the first sharp curve the outside leading wheel left the rail, the friction on the outer side bearing being greater than the reaction of the wheel flange against the rail, the same condition as shown in Fig. 2. The car was replaced on the track and carefully run over the rest of the line. Believing that the first derailment was caused by the car being light, it was then loaded to about one-half its capacity and started back home. On leaving another sharp curve the outer leading wheel on the rear truck left the rail evidently for the same reason as in the first derailment. The car was then sent to the shops and carefully inspected, the trucks trammed and everything found to be in perfect condition, but it was decided to increase the clearance between the side bearings to overcome the difference in the elevation of the rails, and they were set with about $\frac{1}{2}$ in. clearance all around, making a bad matter worse. The car was then loaded to its full capacity, and sent out. It took the sharp curves without any trouble, but in running down a grade at a good rate of speed, over a heavy fill, the car began to rock from side to side until the wheels on one side of the car were lifted off the rail and the car was badly wrecked. Roller side bearings with not over $\frac{1}{8}$ -in. clearance were then applied, and the car has been in continuous service over the same line for over a year and has never had another derailment.

It is undoubtedly a fact that under abnormal conditions, such as an excessive elevation of the outer rail on a curve, with a comparatively short approach, and a rigid car with only a slight clearance between the side bearings, that almost the entire load on one end of the car, sometimes exceeding 40,000 lb., is transferred to the outer leading side bearing, and if these bearings are rough cast iron, as are usually applied, the friction between them would be at least 50 per cent or something over 20,000 lb. As these conditions can and often do exist, is it any wonder that we occasionally have a so-called mysterious derailment? In a series of tests made with a pair of unlubricated malleable iron side bearings loaded with 4,000 lb. and the power applied to a lever 31 in. long, approximately the distance from the king bolt to the flange of the wheel on the rail, it required a force of 1,200 lb. to produce motion, while with a roller bearing having a 3-in. roller, under the same condition, only 70 lb. was required to move the load, a reduction of 94 per cent in power required. At the present time there are over one-quarter of a million cars equipped with some of the different designs of anti-friction side bearings, many of the large roads having from 10,000 to 20,000 cars so equipped, and as about 75 per cent of all the cars recently built are similarly equipped, it is reasonable to assume that the results obtained have not been unsatisfactory.

ELECTRIC LIGHTING OF PASSENGER CARS*

BY E. S. M. MACNAB

Engineer of Electric Car Lighting, Canadian Pacific, Montreal

There is a strong demand for electric light on passenger cars from both standpoints of safety and comfort. The possibility of fire in case of wreck is practically nil when electric light is used. Taking the question of comfort, the chief advantage is the application of berth lights in sleeping cars, together with the use of fans in dining and parlor cars, in addition to which may be added a cooler light devoid of all odor which comes from gas lighting, and the ability to place lights in any position in a car where they may be most convenient.

The number of electric-lighted cars in service in Canada and on certain roads in United States in 1911 and 1914 is shown in the table. It is apparent that there is a strong demand for electric lighting in passenger cars, and also that the railways are meeting it in a liberal spirit.

The electric lighting of passenger cars may be divided into three main classes—straight, storage, head end and axle systems.

The straight storage, while it is the simplest system, requires cars being held in terminal yards from six to ten hours for recharging batteries. This system is, therefore, out of the question for transcontinental services, as any road which has not a surplus of rolling stock cannot afford to hold its trains in the terminal yards for sufficient time to charge the batteries. Another disadvantage is the heavy capital cost of installing the necessary battery-charging facilities at all terminals.

The chief disadvantage of the head end system is the want of flexibility, and this is felt where trains have to be remarshaled at junctions and cars switched off on branch lines. This leads to the necessity of equipping a large proportion of the cars on every train with batteries, increasing the capital and maintenance costs. Another disadvantage is the high steam consumption of the turbine.

The axle system, which is the most extensively used, comprises a generator driven by a belt from the axle and a set of

TABLE SHOWING INCREASE IN ELECTRICALLY LIGHTED CARS, 1911 TO 1914.

Railway company	Number of cars equipped 1911	Number of cars equipped 1914	Increase in cars equipped
Canadian Pacific	68	359	291
Grand Trunk	34	164	130
Grand Trunk Pacific.....	..	72	72
Canadian Northern	14	226	212
Total in Canada.....	116	821	705
Pennsylvania Lines East...	902	1,924	1,022
Pennsylvania Lines West...	516	714	198
N. Y. C. & H. R.....	202	1,007	855
N. Y., H. N. & H.....	350	410	50
Lehigh Valley	81	384	303
Great Northern	480	650	190

storage batteries which supply current to the lamps when the train is at rest. As this equipment is applied to each car, it follows that it is an individual unit and can be transferred to any line in any class of service without any adjustment of the apparatus being necessary.

Batteries.—If a number of electricians who operate electric-lighting equipments were asked to name the details which cause the most trouble, I am sure 90 per cent would reply, "the batteries." To maintain a storage battery in good working condition it should, as far as possible, receive about 20 per cent more charge than discharge, but continuous overcharging will cause the plates to buckle, and also create an excessive deposit of sediment, either of which will result in short-circuiting the plates, causing the cells to lose their charge and become "dead." Overcharge will also increase the evaporation of the electrolyte, which, if not replaced by adding water, will result in damage. The ill-effects of undercharge are also to be noted, as, owing to the action of the acid on the plates, in a discharged condition a sulphate of lead is formed which will have the effect of reducing the capacity of the cell which may be removed by a continuous slow charge. As the charge in a set of batteries gradually leaks out when left standing for a long period, electric-lighted cars should not be taken out of service and stored in yards where charging facilities are not available. It is the Canadian Pacific's practice to charge the batteries on all cars not in service at least once a month.

Another source of trouble is the current leaking to earth through the lead-lined tanks, which will take place if the bottoms of the cells are allowed to remain wet. At the point where the leakage takes place in the lining an electrolytic action follows, which eventually produces a hole in the lining, allowing the acid to leak away; this happening in one cell will probably start the rest in the battery box. To prevent this, care should be taken to keep the outside of the cells and floor of the battery boxes as dry as possible and well insulated from the iron work of the cars. My reason in calling attention to these troubles is to bring out the fact that, as the battery maintenance is the heaviest item in the lighting on most railways, considerable sav-

* Abstract of a paper read before the Canadian Railway Club on October 12, 1915.

ing may be effected by paying attention to the various points which tend towards good battery maintenance.

ORGANIZATION

The question of organization is the chief factor to be determined if efficient results are to be obtained. To illustrate the capital expenditure and maintenance costs, take a road having 400 electric-lighted cars. As each installation will cost, say, \$1,500, we have a total expenditure of \$600,000, of which \$800 per car, or a total of \$320,000, is liable to be permanently destroyed through want of attention. Assuming a total of 400 cars at a maintenance cost of \$12.00 per car per month, we have a maintenance cost of \$4,800 per month, or \$57,600 per annum. If by better handling we save one lamp per car per month, we effect a saving of \$180 per month, or \$2,160 per annum. Again, a conservative estimate will place the life of a battery set at five years. Assuming we have twenty-four batteries per equipment and that we increase their life by one year; taking the cost of the batteries as \$630, we have:

Depreciation at 5 years.....	\$126 per annum
Depreciation at 6 years.....	195 per annum
Saving per car.....	\$21 per annum

Multiply by 400 cars and we have \$8,400 per annum saved.

Again, take the question of belt life. A saving of one belt per car per annum will approximate \$5 per car per annum, of \$2,000 per annum on 400 cars.

Summarizing, we have:

Saving of one lamp per car per month.....	\$2,160 per annum
Extending life of batteries by one year.....	8,400
Saving one belt per car per annum.....	2,000
	<hr/> \$12,560 per annum

These figures show what may be saved or lost through proper handling or neglect of the equipments, setting aside the discomfort caused to passengers due to light failures.

There is a considerable difference in the methods of organizing this work on the railroads in the United States. In some cases the forces are controlled directly by a chief electrician, who reports to the master car builder. On some roads the chief electrician acts in an advisory capacity to the master car builder, the forces being controlled by the car foreman; on others the electrical engineer, through his assistants, directly controls the terminal electricians. On one road in the United States the electricians are carried on the car foreman's pay roll, and are responsible to him as far as matters of discipline are concerned, but are responsible to the chief electrician for all technical work. As a general rule, the closer the chief electrician or electrical engineer is to the inspection forces, the more efficient the organization.

The chief electrical engineer should supervise the preparation of the specifications and wiring diagrams for all new rolling stock and see that they are lived up to by the car builders. This is important, as all equipments, as far as possible, should be installed to certain standards; the various conduit runs should be inspected to see that new wires may be drawn in at any time without tearing down the interior finish of the car. The quality of the conduit and wires should also be closely watched, as these items will affect the cost of maintenance in later years.

The generator suspension should be closely checked with the object of providing for sufficient belt clearance; it will well repay any railway to give this point due consideration, as it is no idle statement that fully half the light failures and lost belts are due to insufficient clearance.

The type and location of fixtures should also receive attention. As far as possible, standard types should be used, involving the minimum number of classes of glassware; as a rule, clear, unshaded lamps should not be used, as they are liable to cause eye strain. It is also advisable to standardize one size of lamp, which, on a large system, must be carried in the stores at all terminals.

The introduction of 50-watt gas-filled lamps which have re-

cently been placed on the market should considerably reduce the number of fixtures and also simplify their construction.

MAINTENANCE OF EQUIPMENT

To maintain the equipments in a proper state of efficiency periodical inspection and overhaul are necessary, and any neglect of either will result in a heavy expenditure for renewals.

Each equipment should receive a thorough overhaul once a year, when the generator should be removed from the car, taken apart, cleaned and worn parts renewed, and on being rebuilt should be tested on a special test frame. The batteries should also be taken to the battery house, where each cell should be opened up, the cell box washed out under a spray, all bent plates straightened, and damaged separators renewed. The battery should then be reconnected in the shop and properly charged, when a discharge test should be taken and its capacity noted. After recharging, the specific gravity of the electrolyte should be adjusted and the cell and battery boxes painted. The set is then fit to be replaced on the car. If the car is fitted with lamp and generator regulators they should be reset, the carbons being specially examined. Considerable difference of opinion exists as to whether this overhaul should be carried out at the terminal yards or at the shops of the company. In favor of the former system it is claimed that, by changing the equipments at the terminals, the overhaul is not dependent on the shopping of the cars, which in some cases is not on the twelve months basis. Also that more interest is taken in the work by the yard staffs than by the shop men. The latter method has the advantage of concentrating the work and insuring a standard treatment of each equipment and therefore lends itself to better organization.

Inspection.—A yard force, under the supervision of a chief electrician or foreman, should be located at each terminal where trains originate, and each car arriving should be inspected to see if the equipment is in good working order before leaving on its next trip, and then all necessary running repairs made. At each inspection the height of the acid in the batteries should be noted, and water added, if necessary. Neglect of this will cause sulphating of the plates, decreasing the capacity and life of the batteries.

YARD FACILITIES

The modern battery room is equipped with a washing table on which the elements can be inspected and also a compressed air and water spray over which the cell box is cleaned. Benches should also be provided to hold at least six sets of batteries while they are being charged up prior to being applied to the cars. Acid tanks for mixing new electrolyte and for holding electrolyte removed from cells while they are being overhauled should be provided, together with a press for straightening plates, also steam-jacketed tanks for boiling the acid out of connections, etc. A still should also be installed if Edison batteries are used.

The generator repair room should be fitted with a bench on which a generator may be conveniently dismantled and rebuilt. A work-bench with a vise is also necessary, together with lockers and cupboards.

Battery charging facilities should be provided in the battery room and throughout the yard, in order that the batteries on any car may be charged without switching the car to any special point.

RECORDS

A set of records should be kept in the electrical engineer's office, showing the details of the equipments on each car, together with a separate battery record. A statement of failures should be prepared each month, showing the number of cases of trouble, the type of equipment and batteries with cause of trouble. From this an efficiency statement is made up, showing the number of failures per thousand car miles, also the number

of miles per failure. It is thus possible to watch the operation of the equipments and make comparisons of them from month to month.

ACCOUNTS

The determination of the cost of operating the equipments is one of the most important items to be followed up, as without a proper accounting system it is impossible to trace any of the numerous leaks which may occur in the maintenance. Undoubtedly the most satisfactory method of keeping accounts is one which gives the cost of labor and material of each car per month, from which the cost of the various systems in operation can be ascertained. But such a system is not always possible.

CONSERVATION OF LIGHT

All who are connected in any way with the operation of electric lighted equipment should assist in saving as much light as possible while the cars are in the coach yards, terminals, etc. By all means give the passengers all the light they require, but save the waste. Probably gas lighting is more or less responsible for much of the waste which now prevails, as it is possible to use the gas in the tanks before a train arrives from the yard to receive its passengers, and replenish the tanks in a few minutes, whereas to recharge the batteries of an electric lighted car may take eight or ten hours.

NEW M.C.B. EXPERIMENTAL COUPLERS

The Master Car Builders' Association has recently issued Circular No. 7 from the Committee on Couplers, showing the

Location of the lockset changed from the guard-arm wall to the rear wall.

Lengthening the vertical guide of the lock.

Addition of a longitudinal rib on the knuckle side of the head, supporting the front face of the head.

Change in the lock lifter for top operation, making it detachable from the lock and entered from the top of the head.

Changes to the bar, knuckle, lock and kicker to accommodate the above and other slight modifications.

The principal changes involved in the type D coupler (Fig. 2), which supersedes type B, are as follows:

Addition of a pulling rib to the bottom of the knuckle tail.

Redesign and strengthening of the guard-arm.

Fulcrum boss and front of the lock changed and a corresponding change made in the lock chamber in the bar.

Removal of the unsupported portion of the striking horn on the knuckle side.

Changes to the bar, knuckle, lock and kicker to accommodate the above and other slight modifications.

Fig. 3 shows the comparison of contour lines. The contour lines Nos. 5 and 10 were slightly modified in order to use the same knuckle in either contour line. This was accomplished without decreasing the horizontal angling of the No. 5 contour, and gave an increase of half a degree in angling of the No. 10 contour.

The dimensions of types A and B couplers may be found in the *Daily Railway Age Gazette* of June 16, 1915, on page 1360.

Regarding the use of these couplers in actual service, the committee said, in part, as follows:

"In order that the members of the association will be in a position to select for adoption as a standard either the type C or type D coupler and either the No. 5 or No. 10 contour lines,

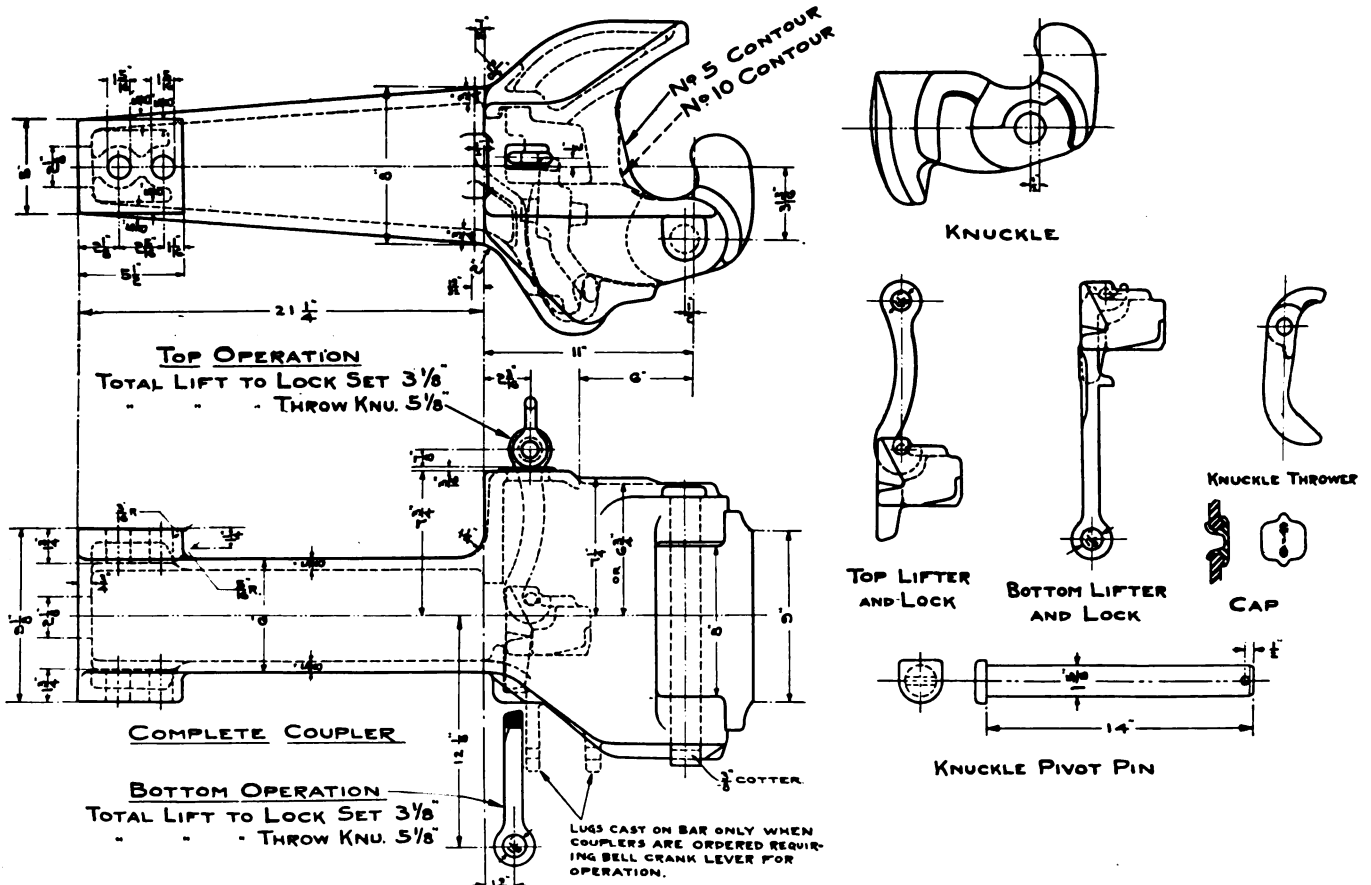

Fig. 1—Type C Experimental Standard M. C. B. Coupler

general outline of the types C and D experimental couplers. The principal changes involved in the type C coupler (Fig. 1), which supersedes the type A, are as follows:

it is essential that each railroad place in service immediately a sufficient number of each of the two types of couplers C and D, with both the Nos. 5 and 10 contour lines, from which to draw

can be accomplished if the temperature of the air is reduced to that of the atmosphere before it enters the brake system and therefore the second of the courses mentioned above is the practicable one. Suppose air at atmospheric pressure to contain only 25 per cent of the maximum amount of water it can carry, it is necessary to raise it to only four atmospheres, or 45 lb. gage pressure, to bring it up to 100 per cent saturation. As the compression continues above this point all excess water vapor will be precipitated unless one thing happens, viz., the temperature is raised sufficiently to prevent the saturation point being reached. During the actual process of compression this is precisely what takes place. The heat generated by compression more than offsets the tendency of the increasing pressure to precipitate any of the water and the result is that no moisture is ever deposited in the compressor while in action.

When the air reaches the reservoir, however, it gives up its heat by radiation but with a relatively small loss of pressure, so that as the temperature falls the saturation point is soon reached and precipitation takes place. This process of precipitation continues until the air in the reservoir is either of the same temperature as its surroundings or until some of it is drawn off into the system. It may be that air leaves the main reservoir always at or about 100 per cent saturation and therefore at the precipitating point. But if the temperature drops no further the remaining water vapor will continue in the air as such throughout its course through the system.

Expansion, it is true, will take place throughout the system during the functioning of the parts and will result in dropping the pressure, thus tending to raise the saturation point and simultaneously in reducing the temperature, thus tending to lower the saturation point. However, with the pressure used in ordinary air brake work there is no place in the brake system where the expansion will be sufficiently great or rapid, that the second of these antagonistic features can predominate and result in precipitation, provided the system is properly installed. That the opposite effect can be produced is quite true. For instance, a very considerable drop in pressure at a fast rate could be brought about by a restriction at some point in the conduit through which the air has to pass. What might happen in such a case is that in manipulating the brakes the air would expand very rapidly through this restriction and moisture would be deposited on the walls of the conduit. This would become frost and further restrict the opening until finally the pipe would be closed.

The general practice of the day in the compression and transmission of air does not seem to make adequate provision for disposing of the water deposited by the air while cooling. In connection with the compressor, and usually quite near it, a receiver or reservoir of considerable capacity is provided, the most important function of which is, or is assumed to be, that of collecting the water that may be precipitated by the compressed air. In too many cases this receiver fails of its mission or only partially collects the water from the air, because if the compressor is working constantly and rapidly, as it usually does, the air goes through the receiver and out of it and into the system before it has time to cool. The air after compression will not drop all of its water until it is thoroughly cooled and the cooler it gets the greater will be the quantity of water liberated. Cases are quite common where a second receiver placed at the farther end of a pipe-line has effectually cured the freezing up by removing the congealable liquid. To get rid of all trouble from water vapor in the air, and the precipitation and possible freezing of it, care should be taken that when the air passes a point where it is still at full pressure and has reached its lowest temperature, such means of drainage shall be provided that none of the liberated water shall be carried into and along the pipes beyond that point. To guard against the air reaching the brake system at a temperature above that of the atmosphere and against great and rapid expansion until after it has passed the operating mechanism are the only things that can be done with compressed air to

prevent precipitation and its consequent ill effects. The above considerations demonstrate the prime importance of having an amount of radiating surface in the main reservoir and connecting pipe of an air brake installation sufficient to cool the compressed air to atmospheric temperatures before it is passed into the brake system. Also that no restrictions exist in the piping between the container and the device through which it is delivered to the air brake system or operating apparatus unless such restrictions be placed where the temperature is always above freezing.

To facilitate the cooling of the air the piping and reservoirs should have as free an exposure to the atmosphere as possible in order to obtain a good circulation as well as to avoid the heat of the locomotive firebox. Ample capacity should be provided for in the storage reservoirs to insure air free from moisture being delivered to the brake system even though the reservoirs are called upon to furnish quantities of air in rapid succession to the brake system, as is the case in taking a heavy train down a long grade. The reservoir should be provided with drain cocks of large capacity and should be easy of access. The installations should be so made that the radiating pipe will drain into the first reservoirs and that the drain cock is at the lowest point of the reservoir. Special care should be exercised to eliminate pockets and reheating. With all of this precaution, if the reservoirs are not drained regularly, the water will be carried into the brake system.

To facilitate the installation and to obtain the greatest amount of cooling area, it has been found that to divide the reservoir capacity into two units and have each reservoir of relatively small diameter in comparison with its length (proper volume considered) gives the best results. In addition to this it is necessary that a sufficient length of radiating pipe be provided for radiating purposes between the compressor and the first reservoir and between the two reservoirs. This length of radiating pipe will be determined by climatic conditions and will therefore vary somewhat, but should never be less than 25 ft. in length in either case. The undesirable results enumerated are cumulative and influence the entire brake system and its operation, and although many more reasons could be given and examples cited, sufficient has been said to demonstrate the importance of a proper consideration of this problem.

MAKING GOOD CAR INSPECTORS*

BY C. S. TAYLOR

General Foreman, Atlantic Coast Line, Wilmington, N. C.

Good car inspectors, like good roundhouse foremen, are "born and not made." As the demand far exceeds the supply, it has brought about quite a problem as to how to overcome the deficiency. It has been solved on our road to a great extent.

We hire a boy from 18 to 20 years of age, one from the country preferred, and take special note of his physical qualifications. We first place him in the car repair yard as a laborer, his duties being to handle stock from the material piles and storehouse to the cars; we also let him assist car repairers in repairing cars, giving him a knowledge of car construction and the names and uses of different parts of the car. After he has proved himself proficient and a good worker we place him on the wrecking force at the first opportunity. All laborers on the wreck force are white. This gives him experience that he would not get in the shop, and he becomes familiar with failures of different parts of the car; if a wreck is caused by poor inspection it impresses on him the importance of close inspection. After working a while on the wreck force, we place him as can inspector's helper and furnish him with an M. C. B. rule book and the loading rules. He is now commencing his real education as car inspector. The duties of the car inspector's helper are to assist the inspector as much as possible, working trains in and out of the yard. More responsibility is placed on

* Entered in the Car Inspectors' Competition, which closed October 1, 1915. For prize article see November issue, page 575.

him as he shows a fitness to assume it, until he is competent to hold the position of car inspector.

His ability is not alone rated by observation by the chief car inspector, but also on his knowledge of M. C. B., loading and safety appliance rules. This latter is arrived at by his answers to questions which are sent out each month by the billing clerk instructor, and also by the supervisor of car repairs. The supervisor of car repairs issues practically all questions on safety appliances, and billing clerk instructor issues questions on M. C. B. and loading rules. These questions are sent out monthly to the car foremen, their clerks, chief car inspectors, their clerks, all car inspectors, and all car inspector's helpers. The answers are sent in by each individual and corrected and returned to him. Besides educating the men as to the different rules, it has also created quite a rivalry among them, which brings about more or less discussion as to the interpretation of the rules, and is one of the greatest educators that we have.

A good inspector should be thoroughly familiar with all M. C. B. loading and safety appliance rules, have a fair education, write a legible hand, be sober and industrious, a close observer, realizing and appreciating that a small oversight on his part may result in a serious accident, causing the loss of thousands of dollars; he also should be familiar with the working principles of air brakes and know how to locate defects in the equipment and make quick repairs. He should, above everything else, have good judgment and loyalty.

DESIGN OF STEEL PASSENGER EQUIPMENT

BY VICTOR W. ZILEN
Associate, American Society of Mechanical Engineers

III TRUCKS

In Fig. 3 is diagrammatically shown a four-wheel truck, which may represent any type of the four-wheel truck; we are interested in the nature and intensity of external forces, and the effect which they may produce in creating internal forces in the structure itself. The method of determination of stresses in one type of truck may be applicable to any other under the same system of loading.

The condition of loading of a truck frame, which will probably be the maximum, will be that based on the capacity of the axle. The load on the truck frame is that which is transferred from

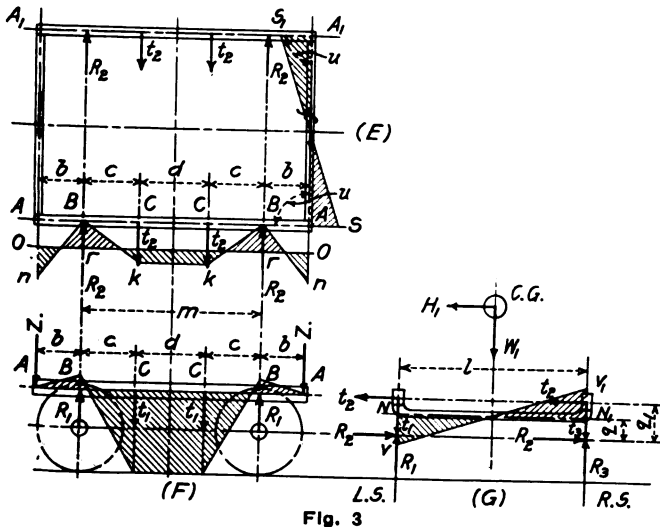

Fig. 3

the elliptic springs through the spring hangers; it is the total vertical pressure plus or minus the load due to the tendency of car to tilt when passing sharp curves at high speed.

It will be remembered that P_1 and P_2 are the pressures on the springs on the left and right sides of the truck respectively, as

found by formulas (23) and (24) in connection with Fig. 2.* H_1 is the horizontal force at the center of gravity of the weight on the springs. Now, in Fig. 3 let

$$t_1 = \frac{P_1}{2} = \text{vertical load per hanger, left side of truck.}$$

$$t_2 = \frac{P_2}{2} = \text{vertical load per hanger, right side of truck.}$$

$$ts = \frac{H_1}{4} = \text{horizontal load per hanger.}$$

We may then proceed to determine the value of R_1 and R_2 . For equilibrium horizontally, we have

$$R_2 = t_2 \dots \dots \dots (30)$$

and vertically

$$t_1 + t_2 = R_1 + R_2 \dots \dots \dots (31)$$

Taking moments about N , we have for rotary equilibrium of the truck on the axle

$$2R_2q + 2t_2(q_1 - q) + R_2l - t_2l = 0,$$

which by substitution from equation (30) and transposition, becomes

$$R_2 = t_2 - \frac{2t_2q_1}{l} \dots \dots \dots (32)$$

From equation (31) we find that

$$R_1 = t_1 + t_2 - R_2$$

and substituting from (32)

$$R_1 = t_1 + \frac{2t_2q_1}{l} \dots \dots \dots (33)$$

Side Frame, Vertical Loading.—Considering only the external forces acting vertically on the side frame it will readily be seen that equilibrium is produced when $R_1 = t_1$. It is thus

evident that $\frac{2t_2q_1}{l}$ is an internal force due to the couple

t_2 and R_2 , and is delivered vertically to the ends of the side frames by the end rails. It is positive, acting downward, on the left side, and negative, acting upward on the right side. Let this force be

$$Z = \frac{2t_2q_1}{l} \dots \dots \dots (34)$$

In considering vertical moments in the side frame, let

x = any distance from A.

From A to B, or for values of $x < b$

$$M_v = Zx \dots \dots \dots (35)$$

Similarly, from B to C where $x > b$ and $< b + c$.

$$M_v = Zx - R_1(x - b) \dots \dots \dots (36)$$

and from C to C where $x > b + c$ and $< b + c + d$

$$M_v = Zx + t_1(x - b - c) - R_1(x - b).$$

But from (33) and (34) we find that $t_1 = R_1 - Z$. Substituting this value for t_1 in the above and combining

$$M_v = Z(b + c) - R_1c \dots \dots \dots (37)$$

It will be seen that this is the value of M_v for $x = b + c$, which indicates that there is no change of moment between the hangers. The last three equations give vertical bending moments in the side frame toward which the car is swaying.

End Frame, Vertical Moments.—Since the vertical force Z at the ends of the side frames is the effect on them of the rigid connection to the end rails, it is the result of a bending moment in the latter. It was found to be positive at one side of the truck, and negative at the other. For any distance from N or N_1 its value will be

$$M_v = Z \left(\frac{l}{2} - x \right) \dots \dots \dots (38)$$

Substituting for Z its value in (34)

$$M_v = t_2q_1 \left(1 - \frac{2x}{l} \right) \dots \dots \dots (39)$$

the value of which is a maximum at the fixed ends and zero in the middle.

Side Frame, Horizontal Moments.—So far we have been dealing with forces acting on the truck frame vertically, now we shall investigate the effect of forces acting horizontally. First,

* See October number, page 515.

consider the side frames hinged to the end rails at A and B , with two concentrated loads t_2 at a distance c from the reactions R_2 . Then the moment at B is zero, and at C is

$$M_b = t_2 c \dots \dots \dots (40)$$

which is also the value from C to C .

Now consider the frames fixed at the ends to the end rails, with the same conditions of loading as before. This is the case of a beam built in at the ends in which the slope at the ends is necessarily zero. For this condition it is necessary that the moment at B have a value equal to the mean bending moment for the freely supported beam under the same condition of loading. Therefore the moment at B , which is the same as that at A , is

$$M_b = \frac{t_2 (d + c)}{m}$$

But from Fig. 3 it will be seen that

$$d + c = m - c$$

and substituting

$$M_b = t_2 c \left(1 - \frac{c}{m}\right) \dots \dots \dots (41)$$

Midway between A and B

$$M = 0.$$

The moment at C or from C to C is

$$M_c = t_2 c - t_2 c \left(1 - \frac{c}{m}\right), \text{ or}$$

$$M_c = \frac{t_2 c^2}{m} \dots \dots \dots (42)$$

End Rail, Horizontal Moments.—Since the moments in the side frame at the corners are the result of the rigid connections to the end rails, it is evident that maximum moments of the value shown in formula (41) exist in the end rails. These act in opposite directions at the ends of each rail, and the value at the center is zero.

In designing the members of a truck frame, the shear and torsion should be kept in mind. For instance, the position of R_2 , with respect to the side frame is at a distant q , hence the twisting movement T , at the end of the side frame from A to B is

$$T = R_2 q \dots \dots \dots (43)$$

In this case bending and torsion are more important than shear. The bending moments for any point in the members of the truck frame may be determined graphically as shown in Fig. 3. In this case it is necessary to calculate the maximum moments by the use of the formulas given above, lay them out to scale and complete the diagram by connecting the points thus determined with straight lines.

Example.—The following numerical example will serve to illustrate the use of the formulas:

- $P_1 = 43,600$ lb. = vertical pressure on elliptic springs on one side of truck as determined by formulas (23) and (24).
- $W = 31,000$ lb. = vertical pressure on axle.
- $W_1 = 52,000$ lb. = weight on elliptic springs, both sides of truck.
- $H = 17,277$ lb. as determined by formula (11).
- $H_1 = \frac{W_1 H}{W} = 29,000$ lb.
- $l = 76$ in.
- $t_1 = \frac{P_1}{2} = 21,800$ lb.
- $t_2 = \frac{H_1}{4} = 7,250$ lb.
- $q_1 = 14.5$ in.
- $m = 72$ in.
- $c = 22$ in.
- $b = 18$ in.

The vertical moment in the side frame at B is found by formula (35) to be

$$M_v = \frac{2 \times 7,250 \times 14.5}{76} \times 18 = 2,760 \times 18 = 49,700 \text{ in. lb.}$$

and the moment at C and between C and C by formula (37) is

$$M_v = 2,760 (18 + 22) - (21,800 + 2,760) \times 22 = -430,000 \text{ in. lb.}$$

The vertical moment in the end rail is found by formula (38) to be

$$M_v = 2,760 \times \frac{76}{2} = -105,000 \text{ in. lb. at } N$$

$$M_v = 2,760 \times \frac{-76}{2} = -105,000 \text{ in. lb. at } N_1.$$

The moments thus obtained are all that are necessary to

construct vertical moment diagrams for both end and side members of the truck frame.

The horizontal moments in the side frame at B , by formula (41) are found to be

$$M_h = 7,250 \times 22 \left(1 - \frac{22}{72}\right) = 110,800 \text{ in. lb.}$$

which, with the sign reversed, is also the value at A . It is also the maximum horizontal bending moment in the end rail. The moment at C is found by formula (42) to be

$$M_h = 7,250 \times \frac{22^2}{72} = 48,700 \text{ in. lb.}$$

The resultant moment, due to the horizontal and vertical moments at any point in the frame, is

$$M_r = \sqrt{M_v^2 + M_h^2} \dots \dots \dots (44)$$

The required section of the frame must be such that it will safely withstand this moment; or the maximum fiber stress, due to the horizontal moment plus the maximum fiber stress due to the vertical moment, must not exceed the allowable working stress of the material.

Motor trucks in high speed interurban electric service are subject to the same method of procedure in computing the stresses in the frame as the trailer. The only additional members comprising the frame are two cross bearers, which support the motor nose. These are supported at the ends on the side frame to which the load, due to the weight of a portion of the motor, together with that due to the motor torque, is transferred. The additional bending moment in the side frame is to be added to that already found. Cross bearers having a substantial connection with the side frame may be treated as beams fixed at the ends.

Bolster.—The bolster is a beam supported on elliptic springs near each end. The weight of the car body is transferred to the bolster at the center plate, the car balancing on the center plate when no other force but gravity is acting. When the equilibrium is disturbed, as when the car is traversing a curve, a portion of the load is transferred to one of the side bearings. The distance of the side bearing from the center plate does not influence the resistance to turning of the truck about the center plate, because the pressure, and hence the frictional resistance, varies inversely as this distance. There is an advantage in placing the side bearings as far as possible from the center plate, however, because of the reduction in oscillation of the car body for any given clearance between the body and truck side bearings.

There are two conditions of loading which should be considered: (1) The bolster supported on the springs and loaded in the middle, and (2) the bolster supported at the center plate and side bearing and loaded at the spring near one of the supports.

Referring to Fig. 4, let

- P_1 and P_2 = pressure on elliptic springs from formulas (23) and (24).
- l = distance between spring centers.
- h = distance from center line of bolster to side bearing.

Case (1).—Under this condition of loading, moments at B and D are zero. At C

$$M = (P_1 + P_2) \frac{l}{4} \dots \dots \dots (45)$$

Case (2).—When part of the weight of the car is carried by the left side bearing, the moments at A and C are zero. The moment at B is

$$M = P_1 h \left(\frac{1}{2} - \frac{h}{4l}\right) \dots \dots \dots (46)$$

When the brakes are applied the retarding force at the rail has for its reaction an opposite and equal force at the center plate. The pull of the brake rod, one end of which is connected to the brake levers on the car body, and the other to truck, is also against the center plate. The sum of these two forces is the horizontal load at the center plate. In some cases, however, the brake rod pull is counterbalanced by another rod pulling on the truck levers in the opposite direction, this rod

having one of its ends connected to the car body. With such an arrangement there is no horizontal reaction at the center plate due to the pull of the brake rod. The bolster is supported horizontally in vertical guides at each end. These provide the reactions for the horizontal load at the center plate, and we have a simple beam supported at the ends with the load in the middle. The fiber stress due to vertical bending plus the stress due to horizontal bending must not exceed the permissible maximum working stress of the material.

When passing over sharp curves, switches and frogs one of the very noticeable effects is an abrupt sidewise lurching of the car. The office of the swing hangers is to allow the bolster to move laterally in order to avoid shock. This movement is usually limited to less than two inches, and is checked by the use of helical springs of proper capacity, but if the hangers are sufficiently short no springs are required.

The correct length of hangers for use with or without springs

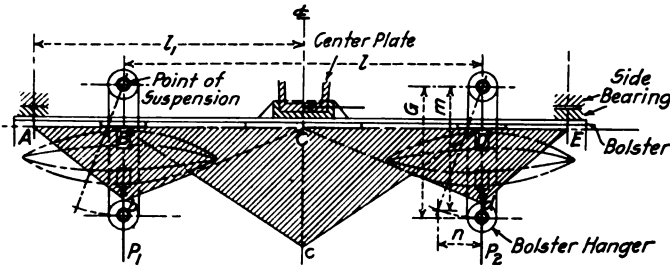

Fig. 4

may be calculated when the limit of the speed of the train on curves is known. In Fig. 4 let

- F = centrifugal force per lb. of train on the curve.
- y = permissible speed of train in miles per hour.
- W = P1 + P2 = weight on the four hangers.
- G = the required length of hangers in inches.
- T = the required lateral resistance in pounds of the spring when solid.
- n = the lateral movement of bolster in inches.
- m = vertical height center to center of the hanger in inches = $\sqrt{G^2 - n^2}$.

Taking moments about the point of suspension

$$Wn = (WF - T) m \text{ or } m = \frac{Wn}{WF - T} \dots\dots\dots (47)$$

For a body weighing one pound, the centrifugal force will be as follows:

- F = .0001165 y² on 10-deg. curves.
- F = .000175 y² on 15-deg. curves.
- F = .000233 y² on 20-deg. curves.

Substituting in (47), the length of hanger for any value of F and any weight of car is

$$G = n \sqrt{\left(\frac{W}{WF - T}\right)^2 + 1} \dots\dots\dots (48)$$

and the resistance required of the springs is

$$T = W \left(F - \frac{n}{m} \right) \dots\dots\dots (49)$$

Example.—Assume the following conditions:

- y = 35 m.p.h. = the limiting speed of the train on a 15-deg. curve.
- W = 52,000 lb. = weight on all hangers of the bolster.
- n = 2 in. = lateral movement of bolster each side of center line.
- T = 0.

For a 15-deg. curve at 35 m.p.h., the value of centrifugal force per lb. of train weight is

$$F = .000175 \times 35^2 = 0.214$$

Substituting in (48), the length of hanger is found to be

$$G = 2 \sqrt{\left(\frac{52,000}{52,000 \times 0.214 - 0}\right)^2 + 1} = 9.55 \text{ in.}$$

The correct length of hanger for use without springs is 9.55 in. Suppose, however, that because of limitations in design two hangers 18 in. are to be used. By formula (49)

$$T = 52,000 \times \left(0.214 - \frac{2}{\sqrt{18^2 - 2^2}} \right) = 3,360 \text{ lb.}$$

A spring will be required having a maximum resistance of 3,360

lb. to check the lateral swing of the bolster in two inches without shock.

Oblique suspension of bolster hangers is a common practice one of the good features of which is the tendency to shift the center of gravity of car body towards the inside of curves, thus adding to the stability of the car on the rails. However, the advantage of inclined hangers is somewhat doubtful, as the arrangement necessitates the use of a spring plank, which is loaded as a strut, the horizontal components of the weight on the hangers acting at the ends. In some cases, on account of clearances, the spring plank must be made heavy enough to bear eccentric loading, which adds to the weight of the heavy construction and results in a few hundred pounds more dead weight, from which no adequate advantage is obtained. Owing to the comparatively low center of gravity of steel cars, the stability on the rails is well on the side of safety and vertical suspension with lateral motion springs is more desirable.

A type of hanger from which more is to be gained than from inclined hangers is a vertical hanger with three bearing points at the top. These are arranged so that the central point only acts until the bolster is near the limit of its swing. The bearing is then transferred to one of the lateral points, thus suddenly increasing the lever arm n (Fig. 4) by the distance from the central to the lateral point of suspension. With this arrangement no lateral springs are required.

WHY IT IS HARD TO GET GOOD CAR INSPECTORS *

BY J. H. HARRIGAN
Southern Pacific Company, Sacramento, Cal.

The demand for competent car inspectors exceeds the supply. This is not surprising when the manner in which these men are secured is taken into consideration, together with the knowledge and qualifications necessary intelligently to perform this work.

An intelligent young man, beyond the age when he can become apprenticed to a well-paying trade, out of a job and willing to do anything, applies for a position. If he is placed on the shop tracks car repairing, he will in time become familiar with details entering into car construction from the top of the rail to the running board. Further, if he has shown by his industry and ability that he is worthy of something better and indicates a willingness to qualify as car inspector, he is placed at air brake work and by close application becomes conversant with the principles governing air brake operation. He is now ready for the train yard, his duties as he passes through the various stages of development embracing the proper care of journals and journal boxes as relates to oiling, packing and re-brassing, repairs of such defective safety appliances as can be looked after in train yards, as well as air brake defects and other light repair work. After he has served at this work and has proved he is of the right stuff, he is promoted to the position of car inspector. This period of training should cover from two to three years, if he is to be thoroughly fitted for his work, which requires a working knowledge of the following subjects:

- Car construction from top of rail to running board.
- Air brake operation and repairs.
- Safety appliances—standard application—penalty defects.
- M. C. B. rules of interchange—delivering line and owners' responsibility—whether defects existing affect interchange.
- Loading rules—recommended safe practice—width and height for clearance.

A car inspector must be somewhat of an executive, inasmuch as he has to arrive quickly at decisions and abide by his judgment. He cannot be vacillatory. His shop experience enables him to decide whether the defect is such as to affect the safety of the car movement and whether there will be less delay to repair it in the train or switch it to the repair tracks.

A car inspector must be honest and not indulge in sharp practice as regards repairs to foreign cars, but live strictly to the

* Entered in the Car Inspectors' Competition, which closed October 1, 1915. For first prize article see November issue, page 575.

spirit of the M. C. B. rules, necessarily implying that he should have a working knowledge of such rules.

A car inspector should see that his employer obtains to the last farthing all the benefits of the labor and material used in making repairs to foreign equipment.

A car inspector must be a safe man; never taking any risks that would incur personal injury to himself or co-workers.

A car inspector must be thorough in his work. When going over a train he must not simply be a sight-seer, but assume the role of an investigator, examining closely the various details that affect the safety of operation. To do this he must bend his back and look underneath the car. Any carelessness in his inspection will show up in subsequent trouble and delay.

A car inspector should subscribe to some live periodical touching on mechanical matters relating to his branch of the work.

A car inspector when he shows he is capable of handling men, a vacancy occurring, is appointed a gang foreman, and as further opportunities present and he can qualify, he will be promoted accordingly. Here, as in every other human endeavor, promotion is not always rapid, but eventually ability will be recognized; if not, it has its reward in work faithfully done.

As to the decided lack of proper material from which to develop car inspectors, thorough in every branch of their work, I attribute this condition to the following two factors:

First, rate of pay is not commensurate with that received by employees in other branches of the railway service, ability and knowledge considered. Cost of living has advanced, but car inspectors are receiving practically the same pay as they earned 10 and 20 years ago.

Second, long hours of service, being obliged to work the 24 hours in two shifts. No doubt this condition is the survival of early railroad practice, it being assumed that, owing to the few trains handled, car inspectors were not employed continuously. In a large terminal yard to-day an inspector is on his feet every minute, every day in the week.

EXPANSION JOINT FOR WATER HEATER

The drawing shows the method employed for heating the water for the wash basins in sleeping and parlor cars on

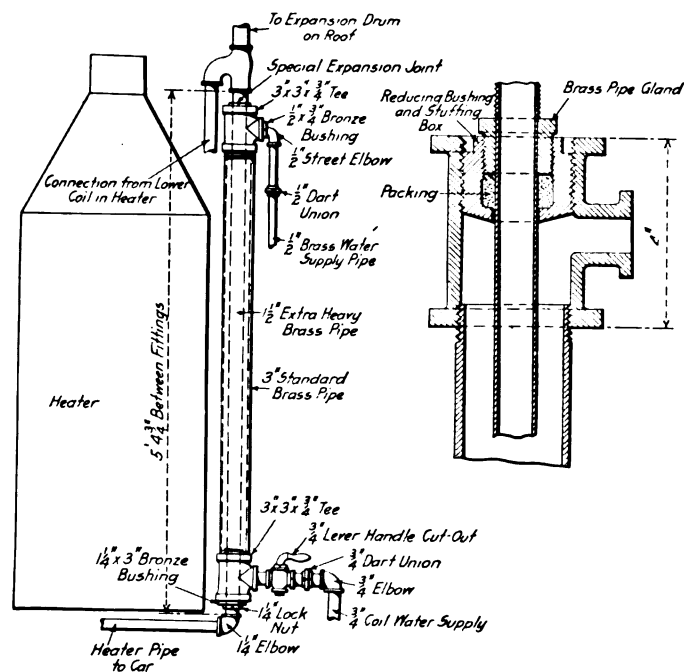

Application and Detail Construction of Expansion Joint for Water Heater on Canadian Northern Sleeping and Parlor Cars

the Canadian Northern. The unusual feature of this arrangement consists in the application of a special expansion joint which does away with the trouble previously experienced from

leaky joints caused by unequal expansion, which is difficult to take care of when a complete screwed joint arrangement is used. The construction of the expansion joint is clearly shown in the engraving. It consists of a 3 in. by 3 in. by $\frac{3}{4}$ in. tee, one end of which is screwed to the 3 in. pipe, while the other end contains a reducing bushing and stuffing box through which the $1\frac{1}{2}$ in. pipe passes, provision being made against leakage by the use of a brass pipe gland and packing. This arrangement was developed under the direction of A. L. Grabum, mechanical engineer, Canadian Northern, Toronto, Ont.

"THE DOCTOR OF CARS"

BY G. C. SLARROW

General Foreman Car Inspectors, Pennsylvania Railroad, Baltimore, Md.

First of all, who and what is a car inspector? What relation has he to one of the greatest industries of the time? Outside of the movement of a car, or a train of cars, this man is entirely responsible at most times for all cars. He is held responsible for ordinary yard inspections covering all parts that are open to the very closest inspection, the only excusable defects being those hidden from ordinary inspection, commonly termed "concealed parts." He must be thoroughly familiar with all lading loaded in open cars, and, in a great many cases, discern bulged and irregular conditions brought about by the improper loading of closed cars. He is called upon to make inspections on the road, at stations and piers, or on individual, private and industrial sidings; such inspections covering the loading of both open and closed cars. The instructions with which a car inspector must be familiar are too numerous to mention, the most important being United States safety appliances requirements, M. C. B. rules of interchange, air brake and train air signal rules, book of rules (general), transportation of explosives and other dangerous articles, rules of loading, dimension book of cars and lading for clearance limits, fire regulations, etc. He is also required to pass a rigid examination on sight and hearing, as well as on air brakes. He must be familiar with all miscellaneous instructions issued from time to time pertaining to his work. This outlines pretty clearly the most important duties of a car inspector.

The car inspector's position is something like that of a doctor; the man carrying the hammer may be classed as a "doctor of cars." The doctor of medicine finds it essential to get all the knowledge he can about the anatomy of a human being before he attempts to practice upon them. In a sense it is just as essential that a car inspector know the physical weaknesses of a car before he attempts to fill the position of car inspector. The following method appears to be the best to familiarize himself with these weaknesses:

First of all, wherever possible, place the man in a position where he will become familiar with both freight and passenger cars. Have him understand that if he desires to hold the position of car inspector, he must familiarize himself with all the rules of the work, it being understood, of course, that he will first be employed as a car cleaner, car oiler, or car repairman. Have the applicant pass the sight and hearing examination and air brake examination while employed in the capacity of one of these classes and arrange to work him in the place of regular men off duty, and, wherever possible, with an older man. Have him understand that he can go to the gang leader for any information that he desires, and have the gang leader understand that he is to instruct the man as to his work. This will turn out competent car inspectors. It will generally be from two to four years before the man gets a regular position; during all this time he is fitting himself for it, and it goes without saying that when the opportunity presents itself he will be thoroughly familiar with the work. So much for the ordinary car inspection work.

Interchange work is a branch of the car inspection department

* Entered in the Car Inspectors' Competition, which closed October 1, 1915. For first prize article see November issue, page 575.

that requires a man with a complete knowledge of the M. C. B. rules. A man with a short experience as car inspector cannot make good in such a position. Generally speaking, the position of interchange inspector pays better, as it carries with it more responsibility. There is no doubt but what there are a great many car inspectors who do not take any interest whatever in the interchange work from the fact that they do not come in contact with it, and the interchanging of cars is an added feature to the duties of an ordinary car inspector.

Seniority should not govern the appointment of an interchange inspector. It would seem rather that the appointment should be based on alertness and aspiration for that class of work. The first step in his development should be to familiarize himself with all the M. C. B. rules of interchange, etc., while he is working as an ordinary car inspector. He should be allowed to work in the place of regular men off duty at interchange points whenever possible; always at points where there is more than one interchange inspector stationed, which will insure the proper supervision of his work by an older interchange man. Both the gang leader and the older inspector should be instructed to watch the man's work and give him all the information they can concerning the duties. When a position is open for the man he should be placed at a point with an older man for a while until he is thoroughly familiar with interchange work.

The duties of a car inspector vary according to local conditions. In some cases they do nothing but inspect cars; in others they make repairs in the yards, where no repairmen are located. There are points where no oilers are located and the inspectors do all the oiling.

The chances are very remote for promotion, the only promotions open to car inspectors, as a general rule, being to positions as interchange inspectors and gang leaders. The difference in the compensation is slight. From experience I would say that about 8 per cent. of the car inspectors are promoted to one or the other of these positions during their time of service.

PROPER HANDLING OF EQUIPMENT*

BY E. E. BETTS

Superintendent Transportation, Chicago & North Western

It is generally admitted that the present practice for handling foreign cars by the transportation and mechanical departments results in great economic losses to the railroads. Under the present practice of using cars regardless of ownership it is of common occurrence that their absence from home lines is indefinitely prolonged. They run without proper mechanical attention from one road to another, their condition growing steadily worse until they become a menace to the safety of trains and dangerous to life and limb. They are then taken out of service. They may be patched up and sent limping home for the owner to rebuild or destroy, or, perhaps, that is done by the road having the old worn-out cripple in possession when it finally lies down and can go no farther, but in any event the results are the same—the owner pays the bill and is most injured by the practice of neglect.

A car absent from the home line, we will say six years (and that is not unusual), becomes afflicted with old defects, some of them owners' defects, others users' defects. The car is finally taken out of service, and is then offered in interchange to a road which is known in our parlance as the "home route." The home route line rejects the car on account of its condition, and, pending a settlement of the question as to who is responsible for its condition and should make the repairs, it is held at the interchange point until the per diem accruing thereon is frequently many times greater than the cost of the repairs would amount to.

In other cases, especially in large terminals like Chicago, the

failure to inspect and properly repair cars, and the attempt to pass them from one road to another in defective condition, create a heavy terminal expense where belt lines are used as intermediate links, and greatly increase the per diem earnings of idle and unserviceable cars.

The failure to keep cars in repair applies to all railroads in greater or less degrees. Probably no railroad is free from that charge. In some cases it is undoubtedly a studied policy; in others it is chargeable to a lack of facilities, indifference and carelessness of employees, and various other reasons, but in our judgment under any and all circumstances it is a mistaken policy, because the interests of railroads are linked together in this proposition so that what injuriously affects one injuriously affects all.

One of the fundamental principles of the Master Car Builders' rules is that, "Each railway company must give to foreign cars, while on its line, the same care as to inspection, oiling, packing, adjusting brakes and repairs that it gives to its own cars." This virtually makes the attention which a road gives to its own cars the standard it should give to foreign cars.

If this may be taken as a declaration of principles, it is open to construction by the individual, and is, therefore, of little or no value for the government of such interests as are combined in this proposition, and which the Master Car Builders' Association is supposed to protect and to properly provide for.

The Master Car Builders' rules make owners responsible for, and therefore chargeable with, the repairs to their cars necessitated by ordinary wear and tear in fair service, so that defect cards will not be required for any defects thus arising, and, if we are able to construe this rule properly, it is based on the idea that cars afflicted with defects that owners are responsible for may be returned to the owners for repair, and here we believe is the cause of all our difficulties where the mechanical department is involved, because it virtually permits railroads to avoid making repairs to cars and permits them to be sent home for that purpose. We believe this to be a fatal defect in the Master Car Builders' rules.

Box cars are loaded promiscuously by railroads which have no direct connections at Chicago. When they enter the Chicago territory, they are pooled, loaded anywhere and everywhere and their absence from owners covers long periods. Result—The cars lose the channels of "home" (no short-routing being permitted) except by circuitous routes resulting in excess mileage and the handling lines are unwilling to repair them, each railroad basing its justification for the refusal to repair cars upon the short period the cars are in its possession.

In large terminals like Chicago, some one should have arbitrary power to schedule cars for repairs under Rule 120 and check up to see that they are properly made—then the theory and practice under M. C. B. rules 1 and 120 become consistent and effective, and such box cars which have no direct connection with car owners' railroads will be repaired and placed in revenue service. Until a change is made along these lines, our difficulties will continue.

Another principle fully set forth in the Master Car Builders' rules is, that cars offered in interchange must be accepted if in safe and serviceable condition, the receiving road to be the judge. The owners must receive their own cars, when offered home for repairs, at any point on their line, subject to the provisions of the rules. This is indefinite. It confers a latitude upon the receiving line which everybody recognizes as being eminently proper, as naturally the right to determine the safety and serviceability of cars to suit the receiving line rests with itself, and from that decision there can be no appeal. It may refuse the car, and there the matter seems to hinge. There is no standard of principle in such a rule as that, and it can only result in endless disputes, bad delays, useless expense, and just as soon as you appeal from the decision of the receiving line you take away the right conferred by the rule, and the rule then becomes void and of no effect.

Illustrations are not wanting to show in the most emphatic

* Abstract of paper presented at the September meeting of the Western Railway Club. As explained by Mr. Betts, this paper was also presented to the General Superintendents' Association of Chicago as a report of a special committee, of which Mr. Betts was chairman, appointed to make a study of the handling of equipment.

manner that the amount of unnecessary mileage incurred by railroads in moving cars in an opposite direction from home in order to get them home is almost beyond belief.

If we are to secure proper and unrestricted movement of cars, and be able to employ them to their fullest extent, they must be kept in repair by the mechanical department. This seems to be a simple proposition on paper, and, inasmuch as repairs that owners are responsible for can be charged with a profit, we believe, to the road making them, the work should be done, and we can see no reason why it is not, unless the question of facilities, labor, supply of materials and other mechanical disabilities make it impossible. Where that is the case the cheapest, best and most rational thing to do before the car becomes in a dilapidated condition is to send it home direct to the owners and let them repair it, and such a car should not be made to travel 2,000 or 3,000 miles in order to cover an intervening area of 100 miles or less.

The judgment of the mechanical department is accepted by the transportation department in all cases where the safety and serviceability of cars are concerned. At all interchange points rigid inspection should be maintained. Cars that are offered in interchange under load not in serviceable condition should be transferred, and the empty returned to the delivering road, but if the transfer of the shipment is impracticable, some arrangement should be made to send the car through to destination, provided that it is safe, and when unloaded at destination, if it is wanted for a return load, or a load in another direction, the road using the car should make all necessary repairs, or should return it to the road it was received from to be continued homeward so that the owner may make them.

Individuals will differ as to what is or is not a serviceable condition, and for that reason if it is possible to define it, in a general way, at least, it should be done. There should be a standard of excellence for a freight car which shall govern inspection, and a matter of such vital importance to the railroads should be regulated by well-defined mechanical rules.

The remedy for the troubles that afflict the car supply, the handling of cars so far as the transportation department is concerned, is to be found in the movements of empty cars in a homeward direction by the shortest and most direct route, the initials of the cars to be the ruling guide, no other marking, carding rules, or regulations being necessary.

RECOMMENDATIONS

The committee also offered a series of resolutions to be referred to the Master Car Builders' Association and to the special committee of 25 mechanical and transportation officers to be appointed by the president of the American Railway Association, in accordance with action taken at its recent meeting in New York. The resolutions urged that the Master Car Builders' Association considered the adoption of a standard of maintenance for all equipment offerable in interchange, and the elimination of an interpretation issued by the Master Car Builders' Association under date of January 1, 1915, in M. C. B. circular No. 16, under which, the committee declared, "loaded foreign cars may be delivered in bad order to a connection and by it hauled to destination, and eventually, regardless of the length of time, be returned empty to the delivering line, if in the same physical condition, thus defeating the intent of M. C. B. rules 1 and 2, which provide for repairs to such cars." The M. C. B. Association was also earnestly requested to take such further action as will make obligatory the handling of bad order cars strictly in accordance with the present terms of M. C. B. rules 1 and 2, and provide for the handling of bad order cars under the following principles:

Cars to be accepted in interchange, either loaded or empty, must conform to the standard of maintenance to be agreed upon.

A loaded car destined to a point within the limits of the terminal at which it is delivered, or a car which must be transferred on account of bad order (not complying with this standard of maintenance), must be accepted if safe to run and

carded with Bad-Order-Return-When-Empty cards, or bad-order transfer cards, to be returned empty to the delivering line.

A car not conforming to the standard of maintenance to be adopted, accepted by a receiving line, must be repaired by the unloading line when empty, or returned to its owner.

Cars belonging to roads with which delivering line has no connection must not be transferred by the receiving line in order to save per diem or avoid repairs, which may be made under load, when such cars are loaded in a homeward direction.

Another resolution referring to good order foreign cars stated that a condition has arisen whereby foreign cars are not handled in accordance with the present car service rules, that under these conditions, during a slump in business, foreign cars are back-hauled thousands of miles over the various circuitous routes the cars may have traversed under load in order to finally reach their home. The American Railway Association Committee was urged to consider the revision of the present car service rules along the following lines:

All equipment, except box cars, shall be considered as special to the line owning and shall be returned to the owners in home route and a penalty applied for any misuse sufficient in amount to make the diverting of a car prohibitive.

Box cars may be loaded in a homeward direction regardless of the route via which they were received.

Foreign box cars belonging to a direct connection must be delivered to and received by that connection, regardless of whence they came, except cars received in switch service.

All box cars of individual ownership must be accepted by owner at any junction point offered.

Foreign box cars belonging to a road with which the holding road has no connection must be loaded for home or in a homeward direction or into home territory, regardless of whence they come, with the exception of cars received in switch service. Foreign box cars may be returned to the delivering line empty if in a homeward direction, but not otherwise.

In the event there is absolutely no loading of any kind that will take a foreign box car loaded in a homeward direction, then provide a means whereby it may be short-routed empty.

Make a reciprocal arrangement whereby one road will haul cars for another empty and equalize on a mileage basis through the medium of some kind of a clearing house. Such an arrangement will provide that cars hauled empty will always be hauled in the right direction, instead of in the opposite direction.

Discussion.—After reading the paper Mr. Betts called attention to the expense entailed in shifting the bad-order cars about. In the Chicago territory 1,445 bad-order cars were returned to the delivering line on account of mechanical defects, at a cost of \$7 apiece, and 861 cars were offered that were not fit for load. In one year 29,779 loads were transferred in Chicago on account of the cars being in bad order and it is believed that most of the cars were loaded when in that condition. Records of certain bad-order cars show that they made 29 and 30 moves before they arrived home.

J. R. Cavanagh, superintendent car service, C., C. & St. L., presented a written discussion favoring a general car pool and the repairing of the cars in pool shops. He believed that such a pool, under the joint jurisdiction and supervision of the American Railway Association, the Master Car Builders' Association and the general traffic associations, would give good results.

A. E. Manchester, superintendent of motive power, C., M. & St. P., believed that too much repair work was being done to perpetuate certain classes of cars and that provision should be made whereby these cars not be allowed to leave the home line.

W. E. Symons called attention to the very small mileage the average freight cars make per day, believing that there is much to be done by the railroads in having the cars promptly unloaded and returned to service. He believed that the roads were not prepared to keep the cars in the condition recommended by Mr. Betts in his paper. J. J. Hennessey, master car builder, C., M. & St. P., agreed with Mr. Symons in this respect, and believed that the paper presented by Mr. Betts was too much of an ideal.

SHOP PRACTICE

RECLAIMING MATERIAL AT LOCAL SHOPS

BY E. A. MURRAY

Master Mechanic, Chesapeake & Ohio, Clifton Forge, Va.

The salvaging of scrap material has received a great deal of attention during the last two or three years, and the saving to be effected by repairing or reworking material which reaches the scrap yard is now quite generally appreciated. Much that has been written on this subject, however, has dealt with reclamation at the central scrap yard. There is much material which can be reworked at division points and placed in service without being collected at the central scrap yard and this phase of the problem has been given especial attention at the Clifton Forge shops of the Chesapeake & Ohio.

Both car and locomotive parts are handled, as well as considerable track material, and a number of special devices have been installed which are almost exclusively used in reclamation work. Of the car material, some is repaired and again placed in service, while other parts are reworked and made use of for other purposes. Freight car truck arch bars are gener-

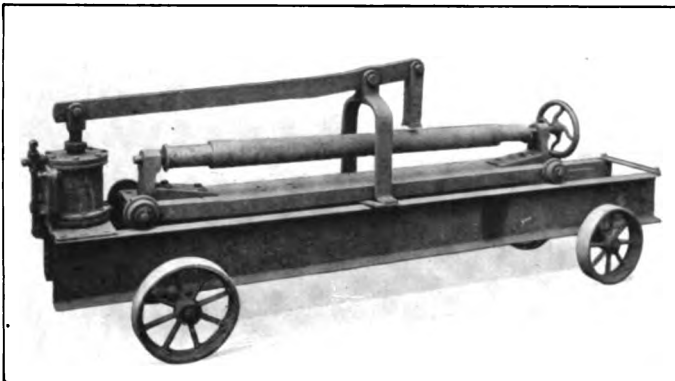

Device for Straightening Bent Axles

ally removed because of cracks, and in some instances are removed in order to be replaced with heavier bars. At this point we use a number of switch engines, and find this material suitable for step brackets for the front and rear ends of switch engines. The surplus material of this kind is sent to the main shop, where it is rerolled into round iron.

Metal roofing which is removed from cars is used for several purposes. It is converted into locomotive tinware, and has been found to give more satisfactory service than can be obtained from the tin, as it will withstand more rough treatment. It is also useful in repairing buildings which would otherwise require the use of corrugated iron. In some instances it has been used in siding up new buildings, the frames of which may have been made from old car sills, thus making it possible to build without requesting an appropriation. It has been found that a greater number of wooden sills are being removed now than heretofore, due to the use of heavy power and long trains with no perceptible increase in the strength of the cars. Aside from their use in the construction of new buildings, sheds, etc., the sills are of use in building platforms and repairing shop floors.

Practically all the old grab irons on cars fail to meet the requirements of the safety appliance standards of the Interstate Commerce Commission, and large quantities of them have been removed from cars which are unsuitable for further use as grab irons. This material is utilized in making rivets for steel car repairs, and it has been found that these rivets serve the pur-

pose as well as those made from new material. A large saving has been effected on this item alone.

Included in the car material which may be reclaimed and again used for its original purpose, may be mentioned couplers, coupler knuckle pins, cast iron car wheels, bent axles, brake beams, brake spreader rods, pressed steel oil boxes and springs, both coil and elliptic. Where the coupler is bent in the body or the knuckle pin holes are spread through the action of a broken knuckle pin, the coupler may be made serviceable again at a very small cost. Knuckle pins which have been bent are heated to a cherry red in an oil furnace, are examined for cracks or other defects and are then straightened and returned to service.

All cast iron car wheels which have been condemned and re-



Hoist for Loading Scrap Wheels

moved because of flat spots, are shipped to the main shop, where they are ground at a cost of 45 cents each. One of the illustrations shows a pneumatic hoist used for loading these wheels and other scrap wheels. It is located close to the scrap wheel storage platform and enables a car to be loaded with wheels in a very short time. It consists of two cylinders, each 60 in. long, made up of five 10-in. brake cylinders placed end to end and held in position by six long bolts passing through heads of $\frac{1}{2}$ -in. steel plate at either end. These cylinders are placed vertically in a pit and a platform 65 in. long by 37 in. wide is supported at the top of the 2-in. piston rods. Guide bars of $\frac{3}{8}$ -in. by 3-in. iron are attached to the lower side of the platform near its ends and extend downward into the pit. The

operation of the device will be clearly understood from the illustration. The wheels are run onto the platform when at its lower position, in which it is flush with the scrap wheel platform. When loaded, the air is admitted to the cylinders and the platform raised to its upper position, in which it is close to the side of the car and flush with the floor.

Car axles which have been removed on account of being bent are taken to the blacksmith shop to be straightened in the machine illustrated herewith. This consists of a truck, the frame of which is made from two 3-in. by 12-in. channels each 12 ft. long. These are spaced 13¾ in., back to back, and the upper flanges form the track for a carriage consisting of a 3-in. by 12-in. channel, placed flanges down, to the ends of which are secured axles carrying cast iron wheels 5 in. in diameter. To the carriage are secured two forged brackets, one of which carries a fixed center and the other an adjustable center. The axle to be straightened is placed between these centers after being heated at the point of the bend. To one end of the truck is secured an 8-in. brake cylinder, the piston of which is connected to the long arm of a lever pivoted in brackets secured to the truck frame. To the short end of the lever is attached a block, which may be brought against the axle at any desired point

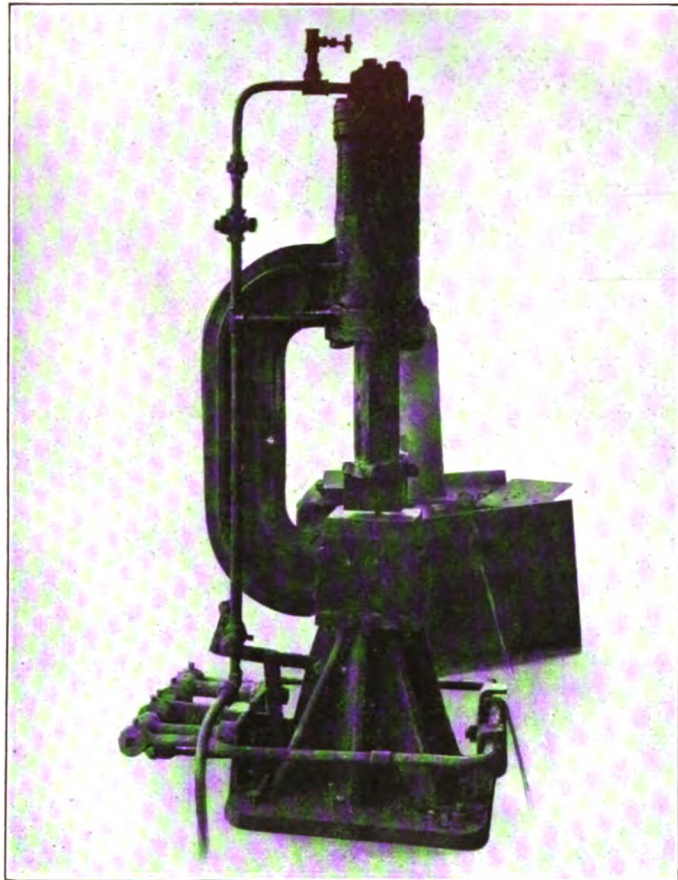

Pneumatic Hammer Used in Reclaiming Track Spikes

by adjusting the position of the carriage. The machine is operated by compressed air, and is portable. By its use axles are straightened without difficulty and at a very small cost.

The removal of brake beams is usually required because of worn brake heads or broken fulcrums, in most instances from the former cause. The beams are reclaimed by the application of new brake heads or fulcrums, as the case may be. One of the largest savings in car material is from this source. Another detail of the brake rigging which frequently fails is the brake spreader rod. These rods are usually made of cast steel, and failures occur at the jaws. Considerable saving has been effected by using two broken spreaders to make one good one. The spread-

ers are cut in two in the middle of the rod and a new spreader produced by welding together two good ends, the work being done in special dies under the steam hammer.

All bent pressed steel journal boxes are straightened and returned to service. Very few of these boxes are damaged beyond the possibility of repair, this being one of the best features of the pressed steel oil box.

Old locomotive boiler tubes, and air pipes removed from both locomotives and cars, unfit for further service need not be scrapped. The tubes form suitable material from which to manufacture washers. The tube is first flattened, after which the washers are punched out, making two washers with each revolution of the punching machine. Split keys may also be made in the same manner, and both the washers and keys give

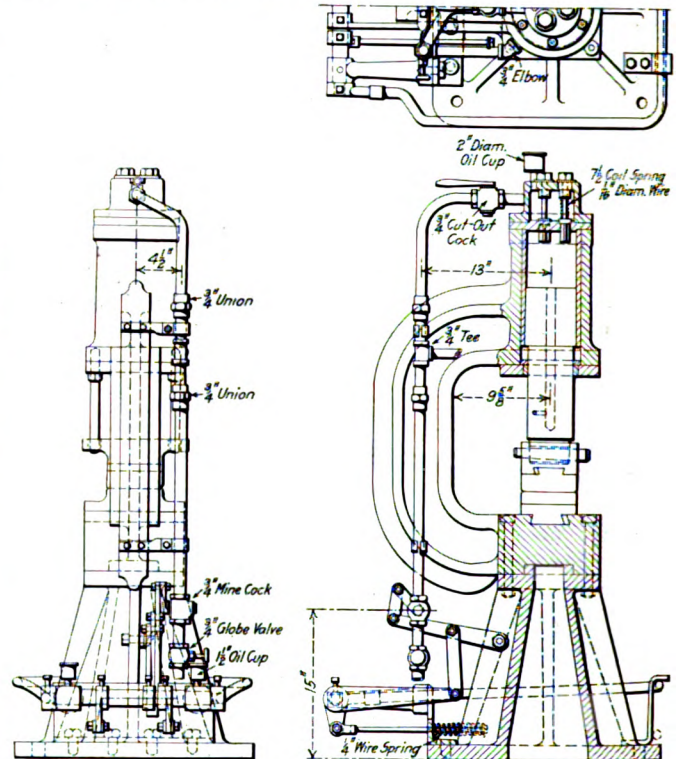

Details of Construction of the Pneumatic Hammer

service equally as good as similar articles purchased from outside manufacturers.

Old air pipes which have deteriorated until they will no longer withstand pressure may be used for sand pipes on locomotives. The saving on this item is in itself not large; it is, however, worthy of attention.

Locomotive driving wheel tires which have been reduced in thickness to such an extent that they are unfit for further use in road service may be worn out on engines assigned to yard service, where the braking periods are not of too long duration and, therefore, do not cause the tires to heat and loosen on the center. This practice has been found very economical, as a sufficient supply of tires of the proper sizes are secured in this manner to practically meet the requirements of locomotives in yard service.

After engine truck and driving axles are removed because of worn journals they are placed in a furnace and thoroughly annealed. They are then given a close inspection for cracks and flaws and turned down for use on engines of lighter capacity, or, in the case of a main driving axle which is larger than the others, it may be used under the same class of engine for the front, intermediate or back, as the case may be. If axles are not suitable for use in this manner, they are sent to the smith shop, where they are converted into different classes of locomotive and car forgings.

A great many air brake hose are cut off where they are

chafed near the nipple, and the shorter lengths again fitted up to be used for shop purposes, such as making connections between the shop air line and the hose of portable tools, transfer tables, air hoists, etc. Air hose, which is of no further service as such, is used for locomotive sprinkler hose and for making water connections to the tender truck journal boxes.

Many globe valves have been thrown away which we have found it possible to put in good repair by renewing the disk, stem or packing nut. Often a valve which is apparently worthless may be made as good as new by reaming the seat and applying a new disk. This may often be done with the valve body in position in the pipe line, thus saving the expense of removing it. It will also eliminate the chance of distorting the valve body, often done in removing it from the pipes.

A large saving may be effected in the air brake department. Air pump pistons, which have been broken, may be welded and governor steam valves, feed valve pistons, etc., may be put in serviceable condition at a very small cost.

Inspirator bodies and lubricator bodies may be reclaimed by bushing the connections in the bodies where the threads have been stripped.

Nuts and bolts are reclaimed by retapping the nuts and straightening and rechasing the threads of the bolts. In some cases the bolts are cut off to a shorter length and rethreaded. Track spikes are picked up over the division and shipped to the shop, where they are sorted, the bent ones being straightened and worked over to be returned to service. Those which are badly deteriorated are scrapped. The pneumatic hammer, shown in the illustration, is used in this work, and has proved very efficient, as it requires but one person to operate it. It was built in the shop at this point at a very small cost. The air supply to the cylinder is controlled by a plug cock operated by a foot lever, the reversal of the plunger being automatically controlled by means of the poppet valves in the cylinder head and the exhaust port through the piston rod.

THE APPRENTICE SCHOOL*

BY R. J. HETTENBAUGH

Apprentice Instructor, Big Four Shops, Mt. Carmel, Ill.

"I am not getting a show," is a very common expression among the apprentice boys in the shop to-day. In a great many shops the company depends on the machinists to instruct the boy, but the machinist is not always inclined to tell everything he knows and the company has no idea what the boy is learning outside of his daily work.

This difficulty has been overcome in quite a number of the larger shops by employing instructors, whose duty it is to help the apprentice over difficulties and teach him how to set up work, sharpen tools and get the highest possible efficiency out of the machine he may be running.

This cannot be considered an extra expense for the boy becomes more valuable to the company early in his course through the help of the instructor and school work; otherwise he will drift along and can only learn by careful watching, and from a year and a half to two years pass before he becomes proficient enough to be of any value.

The greatest step that has ever been taken towards making efficient mechanics has been the installation of the apprentice school. Every boy is put through a general course in drawing and mathematics regardless of the trade he may be learning. This prepares him for the school course he is to follow.

Each boy spends four hours a week in school and is given full time according to his rate in the shop. In addition to this he is required to work from 25 to 50 problems a month at home. These problems all pertain to practical shop work and are a help in his shop studies.

The merits of the apprentice system are evident from the fact that from 12 to 15 per cent of the boys serving time in schools with which I have had experience are now holding salaried positions with the company, and from 50 to 75 per cent are still in the shops.

OIL-BURNING BLACKSMITH FORGE

BY F. G. LISTER

Mechanical Engineer, Spokane, Portland & Seattle, Portland, Ore.

The blacksmith shop at the Vancouver (Washington) shops of the Spokane, Portland & Seattle is equipped with oil-burning forges which have proved entirely satisfactory, the fuel oil even possessing a number of advantages over coal or coke for this class of service. The burners are the same as that described in connection with an oil-burning sand-dryer on page 407 of the August issue of the *Railway Age Gazette, Mechanical Edition*.

A standard size forge is built of fire brick with a combustion chamber and delivery passageway as shown in the illustration. The burner is inserted at the mouth of the horizontal passage-

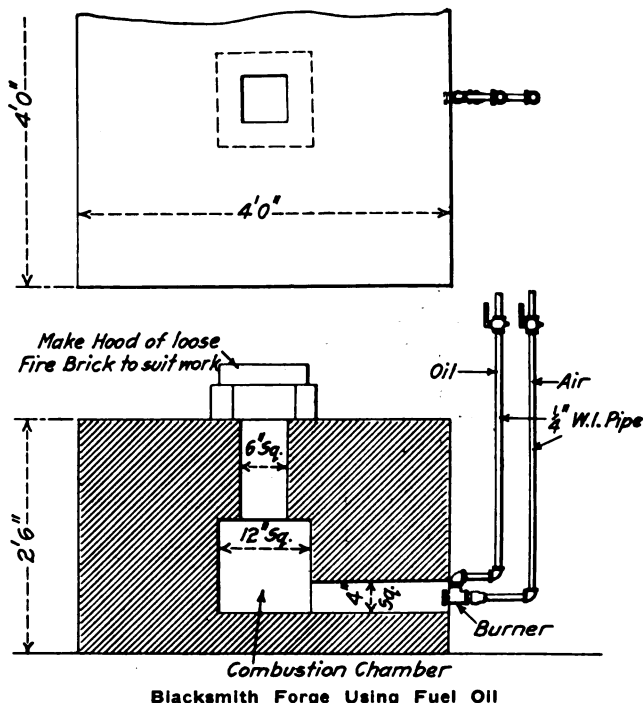

way, the flame striking the wall of the combustion chamber, from which it is diverted upward to the work. A hood of fire brick to suit the type of work to be handled is laid over the fire, which may be made to cover a very small or a very large piece of metal, as required.

Oil as a fuel for use in a forge is especially convenient and economical. The fire is always clean and is ready when needed, without the unsatisfactory expenditure of time in building and keeping it up. About twenty-five per cent more work can be turned out than with a coal or coke fire. This is partly due to the fact that the oil fire covers a greater heating area than either a coal or a coke fire, causing the piece in the fire to heat very rapidly, and the heat penetrates at an even temperature, avoiding any possibility of the outside of the metal burning before it is hot at the center. Coal or coke usually contains either sulphur or phosphorus, either of which, when absorbed by the iron, is detrimental to its quality. Coal burns very rapidly and in many cases contains too much non-combustible matter to give a free-burning, clean fire. These impurities do not exist in oil and no labor is required to convey the

* Entered in the competition on "How Can I Help the Apprentice?" which closed September 1.

fuel from storage to the forges or to clean out the cinders and ashes.

A pressure of air at 20 lb. per sq. in. is used against the oil to atomize and carry it to the work. The oil may be fed to the burner by gravity or by syphoning, the latter method being the most satisfactory, as the flow of the oil automatically stops should the air be cut off from any cause.

The work which is being done on these forges ranges from the tempering of tools to the welding of locomotive frames. Running continuously for a period of eight hours, a forge will consume about 18 gallons of oil.

BAROMETRIC CONDENSER AS AN OPEN WATER HEATER

BY D. P. MORRISON

Electrical Engineer, Pittsburgh & Lake Erie, Pittsburgh, Pa.

In modern railway power houses the supplying of hot water for roundhouse and similar uses, forms an important part of the service of the plant. The heating and circulating system usually is made up of the following elements: A hot well of ample capacity, a heater through which water from the hot well is passed by means of a circulating pump and a pressure pump taking its supply from the heater discharge or from the hot well.

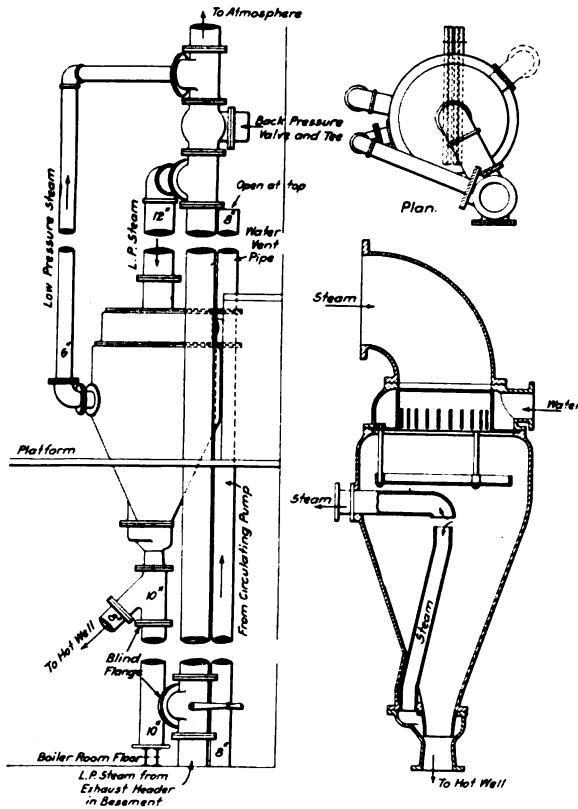

Barometric Condenser Installed as a Water Heater on the Pittsburgh & Lake Erie.

The heater is generally of the closed type, the water passing through the tubes, around the outside of which is steam from the power house exhaust main or from the tank into which the locomotives are blown off.

In one of the plants of the Pittsburgh & Lake Erie there was installed a heater with 2,300 sq. ft. of heating surface which could be kept in efficient condition only by a large expenditure of time and labor, as the tubes scaled rapidly and seriously. In addition to this, their life was reduced by pitting to less than three years. To get away from these two evils and on account of the necessity for immediate retubing, it was decided to abandon this heater entirely and in its place to install one of the open type.

For this purpose there was selected a barometric condenser cone with a capacity of 20,000 lb. of steam per hour at the usual condenser rating. The reasons for this selection were the lower first cost, the smaller space occupied and simpler internal construction, resulting in less interference on account of scale deposits. On account of the nature of the service the absence of an oil separator, usually a part of open heaters, was not detrimental.

This heater was installed without materially changing the piping or other apparatus. The circulating pump, which is of the single stage volute type, motor-driven, draws from the hot well and delivers to the regular injection water nozzle of the condenser, the tail water nozzle being connected to the hot well pipe. The steam enters the cone at the top through the standard nozzle and a pipe is led out to the atmosphere from the vacuum pump connection in order to prevent any building up of steam pressure in the cone in case the back pressure valve should fail to open. The circulating pump lifting capacity is slightly in excess of the height of the steam inlet connection, and it was necessary to provide against the possibility of flooding the exhaust steam stack in case the water tray and orifice at the top of the cone should become closed with scale. This was accomplished by extending the water pipe vertically a short distance beyond the injection nozzle connection, the extension terminating in an open end just below the connection between the exhaust steam line and the top of the heater.

This equipment has been successful from the outset, and since its installation two identical units have been installed for similar use in other plants. With the old type of heater, cleaning of the tubes every six weeks was imperative. The new equipment gave full service for two years before requiring cleaning, which took but a few hours. The operating results have been equally good, the water temperature being maintained at a high point only limited by the amount of steam available. Tests made to determine the heating capacity show that, given a sufficient amount of steam, the heater will supply demands very materially in excess of the present requirements.

In testing the heater, the hot well was filled with cold water and after the circulating pump was started the temperature was noted at intervals until the temperature of the circulating pump discharge had risen to 200 deg. F. The total amount of water heated was 21,115 gal., or 176,500 lb. at 63 deg. F. The table shows the temperature of the water and the rise in temperature as recorded at intervals during the four hours of the test:

Elapsed time, minutes	Water temperature, deg. F.	Rise in temperature, deg. F.
0	63	0
60	128	65
120	172	109
155	192	129
240	200	137

During the entire period a total of 24,180,000 B.t.u. were transferred to the water, an average of 6,045,000 B.t.u. an hour. For the first two-hour period an average of 9,619,000 B.t.u. an hour were transferred. Based on actual tests with the old heater, 3,000 sq. ft. of heating surface would have been required in a closed heater to have reached the performance of the first two hours. These figures are roughly checked by comparison with the temperature rise in the heater. The water was passed through the heater by the circulating pump at the rate of 8,250 lb. per minute and the average difference in temperature of the water entering and leaving the heater was 25 deg. F., thus indicating a heat transfer at the rate of 207,000 B.t.u. per minute.

It is evident that based on the results in the first and second hours, the heater has a capacity much in excess of the requirement. It is believed, however, that with the fluctuating steam supply and water demand the large capacity over the average requirements is fully justified.

This type of apparatus will hardly prove successful in the absence of a hot well and circulating system, but where these are installed, the cost of a heater of this type will be at least 50 per cent less than that of a standard open heater, and 75 per cent less than that of a closed heater.

THE BOILER INSPECTOR AND HIS JOB

Prize Article and One Other from Boiler Inspection Competition Which Closed November 1

Ten papers were submitted in the boiler inspection competition, the first prize of \$35 being awarded to T. T. Ryan. His article and one other follow:

FIRST PRIZE ARTICLE

BY T. T. RYAN

Roundhouse Foreman, Atchison, Topeka & Santa Fe, La Junta, Colorado

Successful locomotive boiler inspection, to meet the federal requirements, involves three important factors:

First, the selection of the inspector.

Second, criticising, encouraging and supporting him.

Third, providing him with the necessary paraphernalia properly to conduct the work.

The first thing to consider in the selection of the inspector is

FEDERAL INSPECTION REFERENCE						
Division _____		Month of _____		Year _____		
Engine Number	Out of Service Stored in Good Condition		Inspection Dates			Remarks
	From	To	Last Annual	Last	This Month	
Blank			4-27-15	9-25	24	
Blank	5-18-14	2-2-15*	5-8-14	9-5	5	*Advance test and flue renewal 8 months
Blank						Receiving general repairs at _____
Blank	(3-20-14) (0-6-15)*	(7-2-15) (Date)	*3-3-14	8-2-15		*Hydrostatic date 3-3-16. Rerow flues by 3-3-17
Blank	8-13-14	12-9-14*	7-30-14 10-23-15	9-24	23	*Advance test and flue dates 3 Mo.

Record of Monthly and Annual Inspection dates

his ability as a mechanic. He should be a practical boilermaker and a competent judge of mechanical work, as under the widening scope of an inspector's duties he must often be a judge of work other than that directly pertaining to the construction of

RECORD OF FLUES AND LAGGING AND FIREBOX DATES					
Engine Number	Flues			Lagging Applied Barrel of Boiler	Firebox Renewed
	Date Applied	New	Spliced		
Blank	4-17-13		198-All	4-17-13	4-17-13
Blank	7-17-15	351-All		7-17-15	New back and front flue sheets and new door sheet 7-17-15

Record Showing the Condition of Fireboxes and Flues and Date of Last Lagging Removal

a boiler. If he can have technical training as well, so much the better, but the former is the more necessary.

The second thing to consider is his ability diplomatically to handle men and situations. One may say that an inspector should not have to be diplomatic in getting the necessary work done; and in a sense that is true, but the fact remains that the successful inspectors are those who have the tact to fit the disagreeable duties of their position in so smoothly that they will not cause friction with the various foremen.

The inspector must also appreciate the routine and forms of office work fully in order to keep a complete and neat record of his work, and he should, by all means, be a man who can truthfully, fairly and creditably represent the company in case legal controversies should involve him as a witness.

The man selected should therefore be a practical mechanic who has an inflexible will that will enable him to insist on a given thing being done, who can fully grasp the importance and the necessary method of recording and accounting. Combined with these qualities he should possess the personal qualities that will make him *persona grata* at the court of approval in the minds of earnest fellow workers.

BACKING HIM UP

Next we come to the difficult task of criticising, encouraging and supporting him. Assuming that he is in a roundhouse, the roundhouse foreman should follow closely the results he is attaining and point out how his methods may be improved, how his dates of inspection can be arranged to move steadily along without requiring overtime or having a group of engines out

BROKEN, FRACTURED AND DEFECTIVE STAYBOLT CARD			
Engine _____			
Flues applied			7-28-14
Hydrostatic test			7-28-14
Hydrostatic test			9-12-15
7-28-14	All	Topeka,	New firebox
8-7-14	None	La J.,	L U G
9-3-14	None	La J.,	In service
10-3-14	None	La J.,	
11-4-14	None	La J.,	Special
12-12-14	None	La J.,	
1-6-15	2	La J.,	45
2-15-15	None	La J.,	
3-10-15	None	La J.,	
4-11-15	None	La J.,	
4-24-15	None	La J.,	L U G
6-5-15	None	La J.,	In service
6-14-15	None	La J.,	L U G
8-27-15	None	La J.,	In service

Record of Staybolt Inspections and Renewals

of service at one time, thereby crippling the division. He should be encouraged to strive to attain more nearly to the ideal of perfection day by day, being satisfied with nothing short of a condition 100 per cent perfect. I might add that "A few flowers for the living that are usually saved for the dead" would go a long way to encourage him.

How do we support this man whom we have chosen for his special qualifications? This is the keystone of the arch. I want to include under this head the machinery and equipment inspector, for under the present scope of Federal law both inspectors go hand in hand. In the past they have been too often like the nameless knight who in the words of the poor

palmer in the banquet hall at Rotherwood, describing the scenes at Acre, "assumed into that honorable company more to fill up their number rather than to aid their enterprise."

Too often there has been an inspector more for the purpose of saying that engines had been inspected, rather than seeing that the work was done. Too long the respect paid to an inspector's report has been scant indeed, and too often the remark, "that is only that fool inspector's report," accompanied the consignment of his work slip to the firebox or the pit; when this was done by the foreman one could expect but little from the workmen.

Supporting an inspector consists in investing him with an authority that is absolute, and in this way, and this way only, will work be done promptly and in a thorough workmanlike manner.

As the foreman is the men are, and if that infernal phrase, "That's good enough," falls with favor on the foreman's ears you can be sure the workman will put up a class of work that measures to that standard, despite the fact that the very term, "It is good enough," implies there is something wrong, and known by all concerned to be wrong. It is easier and cheaper to maintain locomotives in a high state of perfection than it is to maintain a low standard.

We can best support the inspector in the roundhouse by doing the work he finds and doing it when he finds it, and not doing it four or five times to get it done right once.

Generally speaking there is as much time to do a job in a roundhouse one day as there is another, and we should impress on all the fact that there is in a roundhouse only one way to do a job, and that is the right way; there is only one time to do a job, and that is *now*.

FACILITIES AND METHODS

I will now outline a plan of inspection which works well with a minimum of trouble or attention. The forms shown are hypo-

STAYBOLT, STEAM GAGE AND SAFETY VALVE BOARD				
Date _____		Year _____		
_____ Shop				
Engine	Staybolts	Water Glass & Gage Cocks	Steam Gage	Safety Valves

Daily Bulletin of Engines Due for Inspection

thetical cases arranged to show how to take care of monthly staybolt inspections; special staybolt inspections which are made by two inspectors if at the end of four months no bolts have been found broken; hydrostatic tests; flue records; record of lagging, and age of firebox. This information is filed in the numerical order of the engines on an ordinary Yawman & Erbe file with a sheet for each engine. The monthly staybolt reports are made from this file and sent to the mechanical superintendent, and the general and assistant general boiler inspector. All special information is shown on this form and may be ascertained at a glance at any time. This record is complete for four years, and the time consumed in locating the information when wanted has not exceeded five minutes per week.

A staybolt record is also kept, a card being arranged, as shown, to contain a record for two years. At the top is the engine number. The first line shows the date the flues were

applied, the second the date of the previous hydrostatic test and the third the date of the last hydrostatic test. The next date shows when and where staybolts were applied and the age of the firebox. The subsequent dates show dates of inspections, how many bolts were removed, whether the engine was in service or L U G (laid up in good order), special inspections, place of inspection and the number of the monthly staybolt diagram. This last number is assigned to the diagram and it is filed for ready reference. These cards are filed for the engines in numerical order.

A record is thus maintained by which the exact condition of every engine, firebox, flues, staybolts, age of flues and whether new or pieced, age and condition of firebox, dates of monthly inspections, hydrostatic tests, special inspections and dates lagging was removed from boiler, is known, as completed in the past and due in the future. These are kept in numerical and date order and are absolutely correct and up to date, affording the inspector a means of checking his inspections as they fall due

ARCH TUBE RECORD				
Engine _____				
Date	Flue	Workman	Inspector	Cause of Removal

Form of Page from the Arch Tube Record Book

and making it possible to keep in touch with the despatcher, and provide for inspecting the engines without overtime. During one month recently 100 engines were inspected without overtime on a division where most of the freight engines arrive at the terminal in the evening and depart in the morning.

As a further aid a board is placed in the roundhouse as outlined and each morning the inspector marks on it the numbers of the engines to be inspected, and indicates in the column set aside for this purpose whether or not the pops are to be set and the gages tested. The workmen assigned to the task of washing boilers and attending to gages and pops check this board and ask no questions, but get busy at once.

The arch tube record is kept in a record book ruled and headed in accordance with the accompanying outline, one page to each engine assigned to the division and arranged in numerical order. At the end of a year each page shows the actual record of the arch tubes applied during the year, the workman's name who applied them, the inspector's name who inspected them, when the work was done and the cause for removal.

There may be better ways to help an inspector, but these methods give an eminent degree of satisfaction and entail little trouble or expense.

The secret of success, however, with any method lies in perfecting a system that will automatically take care of the work and having the foremen and workmen respect the necessity of doing the work which has been reported by an inspector who is chosen and assigned to his duties because of his competence and common sense.

FACILITIES AND METHODS OF WORKING

BY W. J. GILLESPIE

Boiler Inspector, Pittsburgh & Lake Erie, McKee's Rocks, Pa.

The system adopted after careful study, and the facilities that are given to the inspectors for carrying on the work of locomotive boiler inspection, in accordance with the rules and regulations of the Interstate Commerce Commission, and the methods

employed for keeping of data by the Pittsburgh & Lake Erie are specially good, and are roughly as follows:

THE INSPECTOR'S QUARTERS

The main shops of this road are at McKee's Rocks, Pa., just over the city line from Pittsburgh. A modern 30-stall roundhouse is here maintained; at about the center of the circle and abutting the roundhouse is the toolroom, 60 ft. by 30 ft. Here, centrally located so that he can easily reach any part of the house, the boiler inspector has been provided with quarters. The furnishing consists of a locker large enough to hold a change of clothing, overalls, and such tools as are necessary in the performance of his duties; a writing desk with a drawer to hold his ledger, blank inspection forms, etc.; and a bench on which is placed the steam gage tester. Facilities are also provided for cleaning up and washing.

ROUNDHOUSE EQUIPMENT

The roundhouse is equipped with the Raymer blow-off and hot water system. On the wall, and between each stall, are six valves that control the blow-off, live steam, hot, cold and superheated water, and the high pressure test line. The supply pipe from these valves runs back overhead between the stalls and is dropped to about 6½ feet from the floor at a point that brings it easily within reach for connection to the side or front blow-off cock in the boiler. A pressure of 100 lb. is maintained on steam and water lines. The high pressure test line is worked independently by a pump that is used for this purpose; to use this line the inspector notifies the power house of the pressure desired and the pump is regulated accordingly.

Beside the toolroom window in the roundhouse hangs the daily bulletin board, also the daily work slate, the bulletin board showing the locomotive, number of train to which it is assigned, and time it is due to leave the roundhouse. The work slate governs the work of the water-tender, boilerwasher, flue-blower, boilermaker, cabman and firelighter. The first column shows the locomotive number and a column is also devoted to each of the aforesaid items in the order mentioned. As each completes the work that is required of him he marks O. K. in the column that is assigned to his work, opposite to the number of the locomotive on which the work was done.

METHODS EMPLOYED FOR KEEPING DATA

On the 1st of January of each year a bulletin sheet is laid off in 13 columns. In the first column all locomotives are shown by numbers, and in the order of the numbers. The 12 remaining columns are each headed with a month of the year. When the boiler has been given the regular monthly inspection the date is marked opposite the locomotive number and in the column assigned to the month in which the work is done. Should a hydrostatic test be made at this time, the letter *H* is added to the date of the month. In case the inspection has been made at a divisional point other than McKee's Rocks, a message is received giving this information and the record is marked on the bulletin in the usual way. Thus we are always in touch with the progress of the work and a glance at the bulletin is all that is necessary to find the date on which any locomotive boiler on the entire system is due for monthly inspection or hydrostatic test.

A bulletin of this kind is kept by the filing clerk in the office of the assistant superintendent of motive power, and another is hung in the office of the roundhouse foreman. In addition on the first of each month all boiler inspectors are furnished a list of locomotives that are due to have a hydrostatic test made during the current month, giving the dates on which they are due for the tests. They are also furnished on the first of each year with a list of those locomotives that are due to have all flues removed from the boiler; also those that are due for a five-year test, or the stripping of the entire boiler shell and firebox. The month and date are shown on which

it is necessary to have the locomotive removed from service to perform this work. These lists are furnished by the filing clerk and are attached to a bulletin board which the inspector has for this purpose and which hangs beside his desk. He thus has all this data beforehand and is saved the time and trouble that would otherwise be necessary in hunting it up after the locomotive had arrived in the roundhouse.

At the time that the hydrostatic test is applied—once each year—all caps are removed and exterior inspection of flexible staybolts is made. As a state law requires this work to be done once every 16 months, the delay to the locomotive is avoided that would otherwise occur in having it removed from service four months later in order to have this work performed.

OUTLINE OF INSPECTION WORK

Each morning a clerk in the office of the roundhouse foreman goes over the inspection bulletin sheet and makes out a list in duplicate of all locomotives that are due for monthly inspection during the next 24 hours. One copy of this list is delivered to the foreman in charge at the ashpit, and the other is placed alongside the work slate in the roundhouse. When a locomotive arrives at the ashpit the foreman, by consulting his list, can tell if it be due for boiler inspection, in which case he sees that the fire is dumped before it is sent to the house. On delivery at the roundhouse the hostler marks the number in its place on the work slate, and the floor foreman, by consulting the list which is placed alongside of the slate, is informed of the fact that the locomotive is due for boiler inspection and marks the letters *S. T.*, signifying staybolt test, after the number of the locomotive. This for the information of the boiler inspector, cab workmen and boiler washers.

Should the firebox be equipped with a brick arch, the inspector orders all brick removed. In the meantime the water-tender has made the connection between the feed pipe and the blow-off cock in the boiler; after opening up the latter he also opens up the blow-off valve at the wall and all water and steam are blown from the boiler to a tank at the power house, where the water is delivered to the sewer, and the steam is used for heating purposes. When the boiler is emptied the blow-off valve is closed and the hot water valve is opened; when the boiler is filled it will be under 100-lb. pressure and is ready for inspection.

First, the exterior of boiler and firebox are examined as thoroughly as possible; tell-tale holes are inspected, and mud-ring corners and the interior of the front end are examined for leaks. Next the interior inspection of the firebox is made. Staybolts and radials are tested; flues, arch tubes, seams, grates and rests examined; and all defects are marked with the inspector's red chalk and a record is made in his note book.

The boiler is then ready for the boiler washers and cab workmen. If the repairs necessary will delay the locomotive beyond the time it is marked for departure on the bulletin board, the inspector immediately notifies the roundhouse foreman. He also furnishes the boiler shop foreman with a written report of all defects noted, so the necessary men may be assigned to make the repairs.

The work of the inspector does not end in chalk-marking defects. He must follow up the repair work and see that it is done in a proper manner. If staybolts are renewed he should see that there is a full thread in both sheets after the holes are tapped out; also examine all staybolts before they are applied to be sure that they are properly threaded and not ragged and torn; see that they fit properly when applied, that they are properly driven and that tell-tale holes are drilled to the proper depth. This applies also to all classes of repairs.

Should the boiler be due for a hydrostatic test the method of procedure is as follows: When water and steam are blown out, and it is being refilled, the inspector has the lagging and jacket removed from the firebox, has the steam gage removed and tested, and the steam pipe connection to the gage removed

and blown out, examines the steam cock to it and sees that the opening is clear, after which the gage is replaced. When the stripping of the firebox has been completed and the inspector has adjusted the clamps to the safety valves and the boiler is filled with water, it is ready for testing. The inspector then notifies the power house of the pressure he desires on the test line—always 25 per cent above the boiler working pressure. By opening the valve that controls the test line this pressure is recorded on the gage and is maintained until the inspection has been completed in the same manner as previously described, except that at this time it is good practice to have all grates and rests removed from the firebox in order that the bottom corners and sheets that are behind them may be thoroughly inspected.

When this part of the inspection is completed and the boiler is emptied, the dome cap and throttle box are removed and the interior of the boiler is inspected as thoroughly as is possible from above the flues; the sling stays or crown bars, cross stays and crown bolts are examined, also the front and back braces to see that all pins and keys are in place. The latter are also struck with the hammer to make sure they are sound and taut. The flues are examined for signs of pitting, and the shell sheets and joint seams as far as possible for pitting or grooving.

When the inspector has satisfied himself that the interior of the boiler is in good condition he reports accordingly and the throttle is ground in and replaced and the dome is closed. The caps having been removed from the flexible staybolts, the inspector proceeds with the inspection in the following manner: On the firebox end he strikes each bolt a sharp blow with a heavy hand hammer, going over all bolts in the box. When this is done he proceeds to the outside of the firebox. Here he uses a cape chisel, which is placed against the head of the bolt and struck with the hammer for the purpose of jarring it. After being struck on the firebox end, if the bolt is broken, it will loosen up in the sleeve and on being jarred on the outside as described, will turn around, and is easily detected. When all bolts are thus inspected and replacements are made, the caps are replaced, and after cab work is finished the boiler is again filled up and the working pressure applied. After the inspector has assured himself that everything is in good condition he so reports and the lagging and jacket are applied, the boiler is washed and is ready for firing up.

Where hydrostatic tests are made at various points on the line which do not have the above-mentioned power-house facilities, the boiler inspectors are provided with force pumps. These are converted from locomotive air pumps, the lower chambers of which are removed and replaced with 4-in. cylinders, intake and outlet with necessary connections, regulator attachments to govern the air pressure in the chambers, and air hose connections. These pumps are placed on small trucks and firmly braced and are easily moved to any location in the roundhouse and placed alongside of the boiler that is to be tested. When the boiler is filled with water the blow-off cock is closed and the pump is connected thereto. The supply line is connected to the pump, and the air hose is connected and air turned on; the supply line and blow-off cocks are opened and the pump is placed in operation; the regulator is adjusted until the desired pressure is obtained. This is maintained until the inspection is completed.

In all cases the boiler-washer reports to the inspector after he has finished washing out the boiler; the latter examines the boiler to see that the work has been properly done. To aid them in making this inspection all boiler inspectors are furnished with flashlights about 6 in. long, which are easily carried in the pocket. By inserting this light in the plug holes on the backhead above the crown sheet a clear view may be had between stays from back to front of the crown sheet; then by placing it in each plug hole along both sides of the crown a thorough inspection of the entire surface may be made. Using the plug holes on each side of the firedoor the water leg can

be examined between staybolts for the entire length of the firebox; by using the bottom corner plug holes in this way it can be seen whether all scale and deposits have been washed from the mudring across the front and back and along both sides. The interiors of the arch tubes are examined to see that all scale has been removed therefrom.

At the time that this inspection is made after boiler washing, the work of the cab men is also inspected; the gage cock and water glass cock spindles are removed and the openings examined; the steam gage is removed and tested, and the steam pipe to the gage is removed and blown out before the gage is replaced. When the boiler is fired and the working steam pressure is raised, the inspector sees the safety valves set, tries water glass cocks, gage cocks and both injectors.

When satisfied that these are in good working condition he fills out the inspection form, and after having it signed by the officer in charge, places it in the locomotive cab, after which the forms for filing are filled out and taken before the notary and sworn to and placed in the hands of the filing clerk.

IN CONCLUSION

The annual bulletin sheet renders it impossible for any locomotive to become overdue for boiler inspection without its being known. And the monthly and annual lists that are furnished the boiler inspectors by the filing clerk are ample for their needs and leave them the time that would otherwise be taken from that part of their work, which is of more vital importance—the keeping of the locomotive boiler and firebox in good serviceable condition. The inspector's quarters should be as centrally located as possible. Provide him with a locker to hold his change of clothing; locate it where the clothes which he takes off in the evening will have a chance to dry out before he puts them on in the morning. Furnish him with a writing desk with drawer, and also facilities for washing.

His inspection forms when filed must be clean and free from finger marks. The drawer will keep the blank forms clean, and by washing his hands he can avoid the finger marks, but not by rubbing them off with a piece of waste. He should be provided with a ledger in which to keep a list of the locomotives and in which to make note of all repairs that are made to the boilers and fireboxes from time to time, also making note of their general condition after each inspection. This will enable him to reply intelligently when his superior asks for information as to the condition of any locomotive boiler or firebox that may come under his jurisdiction.

TIRE HEATER.—An economical and effective tire heater in use on the Great Northern at the Dale street shops, is made from ½-in. gas pipe, there being two coils superimposed on each other and connected at one end by a return bend welded to both coils. The outside coil is used for vaporizing the oil, which in this case is kerosene. The second, or inside coil, is perforated with 3/64-in. holes spaced 2½ in. apart. Small legs about 1 in. long are welded to the pipe to properly space it from the tire. The oil is forced into the coils from the reservoir tank by air pressure, and on starting it is vaporized by the application of a gasoline torch to the outside of the pipe. This heater is easy to construct, and by the use of kerosene reduces the cost of operation and provides greater safety.

TWO GOOD SUGGESTIONS.—In a paper presented in the competition on "How Can I Help the Apprentice?" which closed September 1, the following suggestions were made by John Paska, Chicago:

The apprentice should have a day each month to do anything pertaining to his trade and the work done on that day should be strictly examined and judged.

His master should give him a chance to see many things which pertain to his trade, and, if possible, have him make an excursion after a year or half year to some other important shop.

"HOW THE OLD MAN BEAT THEM TO IT"

An Experience with an Efficiency Engineer in a Railroad Shop Plant, and What Came of It

BY HARVEY DE WITT WOLCOMB

"Old Dan" Keefe, the popular superintendent of the locomotive and car repair shops of the R. S. & P. at Wonderly, was "up a tree." He had been fighting against the installation of a shop efficiency system in his shops and had apparently put up such good arguments against the so-called "new fangled" idea, as he termed it, that the very words "shop efficiency" were never spoken in his presence. But this morning he had received, in his mail, a personal letter from the vice-president and general manager advising that an "efficiency engineer" was on his way to Wonderly to make a personal check of the shop conditions, with a view of establishing a "shop efficiency" system.

"UP AGAINST IT"

Poor Old Dan had to read the letter through twice before he could make himself realize that the management had at last "called his bluff," and that his days of absolute power were past. Now, Dan was one of the few remaining mechanics of "the old school" and had fought his way from the ranks up to the highest position by hard work. He had been superintendent so long that he, like every one else, regarded himself as a permanent fixture and had begun to think the railroad could not run without him. In fact, during his administration the shops had made several notable records and these, together with his low cost of repairs to equipment, had been one of his best arguments against the efficiency system. But now it was all over and "Old Dan" could see far enough into the future to realize that one of the first moves the new efficiency engineer would make would be to secure the appointment of a younger and more modern superintendent.

The very thought of being called a "has been" fairly made him sick. How dear everything looked in the office; the chair he was sitting in at his desk was given him by the management in recognition of a special service he had rendered, and, at that time, he had been given to understand his services were indispensable; but now it was all over. As he recalled his past service, the fighting spirit of his Irish nature tempted him to put up a last fight for his position, but then on the other hand, his good common sense showed him that he was too old to fight against such great odds as the management's wishes and a young efficiency engineer who was just starting out in life, anxious to succeed at any cost, so the best thing to do would be to take "his medicine" like a man.

In his own mind he pictured the new engineer as probably being a clerk in some railroad office that had had no real shop experience, but had taken up the "mail course" study of efficiency as a side line and had gotten so swelled up over what he thought he could do that he had dazzled the general manager into giving "his system" a try out.

THE EFFICIENCY ENGINEER ARRIVES

Well, there was no use of crying over "spilled milk," so Dan started out through the shops to have one last loving look at the old place.

As Dan started through the pattern shop he detected the odor of cigarette smoke. Now, if there was one thing that made the "Old Man" "fly off the handle" it was cigarette smoking; then again he was a great "stickler" for shop rules and one of his strongest rules prohibited smoking in the pattern shop. Personal feelings were forgotten immediately in the hunt for the guilty man, and when Dan found that the transgressor was not one of his workmen, but a total stranger, who even had the nerve to light a fresh cigarette while looking directly at one of the many large signs that prohibited smoking in that department,

he was so "wrathy" that for once he could not even "cuss."

The stranger, a young man about 30 years of age, mistaking old Dan's silence for timidity, added fresh fuel to his anger by remarking that in all his experience he had never seen such a glaring example of shop *inefficiency* as the location of that pattern shop so far away from the foundry.

Say, was the "Old Man" hot? Does a bull get mad at a red flag? Well, I don't know how a bull feels when he sees a red flag, but I do know that the "Old Man" had taken a lot of pains to locate and build that very pattern shop just where it now stood, and it was one of the "soft" spots in his heart; and to have a young whip-snapper "sneer" about his good judgment was such a shock to the "Old Man's" nature that his anger overcame his mental ability, and from force of habit he blurted out, "Well, what's the matter with this shop; speak up, my man?"

Instantly "Old Dan" would gladly have swallowed those words, for he didn't want to talk like that; he wanted to fight. But the damage was done, and the young man being anxious to talk, quickly answered that the pattern shop was too far from the foundry, and a great number of steps and valuable time were wasted daily from having to walk from shop to shop; "and," continued the young man, "one of the first things I do at this old plant will be to move this 'mess' over next to the foundry, where it belongs, cut out this unnecessary waste and put this business on an efficient basis."

DAN SEES A LIGHT

Suddenly "Old Dan" seemed to see a great light. Here was a new phase of "efficiency" that he had never thought of. Just think of the net saving in moving a new \$40,000 pattern shop so as to save a few steps a day and at the same time provide a nice cozy loafing-place for the molders. Then again, just think how long it would be before that shop would burn down from sparks from the foundry, the same as the old shop did. The old blacksmith shop was another shop that would have to be moved also, for it was a little to one side of the plant, but as it was a large, roomy stone building, well ventilated and lighted, they had managed to get along with it in its present location. But Dan could see that from the "efficiency" standpoint, it caused him to waste a lot of steps in a year.

Dan's anger was all gone now. He was just the plain "foxy" Irishman that had so successfully run the plant for the past 20 years that the management was going to kick him out now and have a young greenhorn step in that didn't think any more about moving a \$40,000 building than some people would about moving a wheelbarrow out of their way. Well, the "Old Man" wasn't buried yet, and perhaps he could show them a thing or two.

After a few minutes' talk with the young man, Dan excused himself, saying that he had some mail to look over, and that he hoped the young man would stop in at the office before he left. The first thing "Old Dan" did after he got in his office was to give vent to his feelings by having a short war dance around his desk. Just think, when he left the office he had felt that his time had come, and he had gone out into the shop like an old worn-out horse; now he was actually dancing.

DAN GETS BUSY

Dan rang the buzzer for his best stenographer and started to set the stage for the downfall of "shop efficiency" at the Wonderly shops. His instructions to his stenographer were to hide in the closet and to take down every word that the young

efficiency engineer said. "Be sure and copy correctly the figures he gives out," said Dan, "for I think perhaps I can use them to good advantage."

After a long wait, the efficiency engineer was ushered in, and while Dan apparently was very busy, he gave the young man a good looking over. "Well," said Dan, "what do you think of the place, and what are some of the many changes that should be made?"

"You have here a great chance to install my system," replied the young man, "for this is one of the worst places I have ever visited. Take, for instance, your method of wheeling engines. You are still using the old style drop pit, and I propose to take out these pits, install an electric crane and cut the cost of wheeling engines by half." "Very fine," replied Dan, "and what will an electric crane cost?" "About \$8,000 complete—that is what it cost the X. Y. & Z. people to make their installation," replied the efficiency engineer.

Well, to make a long story short, the young engineer was going to move the blacksmith shop, as Dan predicted, at an estimated cost of about \$25,000; move the pattern shop at a cost of about \$40,000; install an electric tram car track through the shop and equip all machines with individual motor drive, which would cost in the neighborhood of \$120,000. Besides he was to have a "supervisor of shop efficiency" and a "supervisor of shop routing" who would get salaries of about \$3,000 a year each. If Dan hadn't got hungry, I believe that young man would still be sitting in his office telling about the great things he was going to do, but Dan was getting sick of such "fairy-tales" and called a halt by going out to lunch.

"DAN KEEFE, EFFICIENCY EXPERT"

That afternoon "Old Dan" ordered some business cards printed that read like this: "Dan Keefe, Efficiency Expert," for he had thought of a plan whereby he could "put it all over" that young engineer, and not only have the pleasure of holding on to his job, but also of teaching the vice-president and general manager a lesson that would make him realize they couldn't pull any "rough stuff" as long as he was alive and kicking.

After giving the efficiency engineer a couple of days to render his report, "Old Dan" made a trip to headquarters to see the V.-P. and G. M. Of course, as everyone in the office knew him, they told him to "go right in" and see the "boss," but Dan insisted on sending in one of his new business cards in the regular manner, and of being presented the same as any other visitor. Dan's visit was at an opportune time, for the V.-P. and G. M. had just finished checking over the efficiency engineer's report, and the great amounts to be saved, as shown by this report, had made the "boss" sit up, and wonder how the old road had ever existed as long as it had.

As Dan went into the office, the "boss" did not greet him very enthusiastically, for he thought that "Old Dan" had come to plead for his job. But Dan quickly changed his opinion when he told him that he had quit, and was now in business for himself. "You see," said Dan, "times have changed, and business must be managed efficiently now to become a paying proposition. As superintendent of your plant for a long time, I have had a chance to study economy, and my experience with the average efficiency engineer is that they plan to 'save money at the spigot and waste it at the bung-hole,' so I am introducing a system where you do not have to invest large sums, but I will take 10 per cent of the money I save for you as my salary. Some of the greatest chances for efficiency are the small things that we do wrong every day and yet go unnoticed."

REAL VERSUS PAPER SAVINGS

At first the "boss" got mad, but when Dan offered to show two ideas to the other fellow's one, that would result in an actual saving for the company, the boss had to "sit up and take

notice." "In the first place," said Dan, "your efficiency expert will recommend the installation of an electric crane to wheel engines. This crane will cost you about \$8,000, and as we wheel about 20 engines a month, that investment will net you approximately \$500 a year, or about 6 per cent on your investment. On the other hand, we have a large plant to keep clean, and at the present time it is costing your company about \$60 a day to do this. With my system I propose to not only clean the entire place, but to keep all scrap picked up as well, by dividing the plant up into several districts and having a gang assigned to every district, from the figures I have here, the approximate cost for this work will be \$35 a day, or a net saving of \$25 per day, which means approximately \$7,500 a year.

"Take your present method of getting rid of the scrap wood in the car yard. You are burning it after picking it up and hauling it about a quarter of a mile. This all costs money, and I propose to have some old employees pick up the wood, saw it up into commercial lengths and sell it by the load to the families that burn wood. From the figures I have here this idea will net your company \$800 a year after paying the wages of your men doing this work.

Well, it wasn't very long before the "boss" saw that "Old Dan" had the goods to deliver, and he realized that where his efficiency engineer had reported that it would take an investment of over \$200,000 to make an "efficiency" saving of about \$20,000 a year, the "Old Man" was proving that this same amount could be saved without making any investment; so he told Dan to go back and prove his statements.

GETTING RESULTS

The rest of my story will have to go unfinished, for "Old Dan" is on the job every day now, and is working out new ideas all the time. A short time ago Dan said to me: "The older I get, the less I know, for at one time I was working my head off and now I am simply playing with the work. Now, I take one job at a time and study it from all sides to see how easily and cheaply it can be done. I started in with some old worn-out employees. Every large plant has some men that have worked all their lives for the company, and when they get old and worn-out, they cannot be fired, so it is necessary to give them light work they can handle. I took my old men and started some to taking care of scrap paper; others to picking up nuts and washers; others to selling scrap wood. I had each man keep an account of how much he made for the company. The first six months we paid eight of these men the sum of \$2,346 in wages, and they had picked up and reclaimed over \$3,000 worth of scrap material.

"I organized scrap inspection committees under my supervision and had the different foremen inspect each other's gangs with the result that the scrap shipped out of here has been reduced by over half.

"We encouraged the men in the shop to make suggestions for economy and offered a cash prize to any man that would make a suggestion by which we could save money. What do you think! The very first suggestion was by one of our common workmen, and he suggested that we use cast iron instead of brass for certain parts on the engines and cars. This one idea alone is saving our company thousands of dollars.

"Instead of buying new machines now, the foremen and men get their heads together and build a machine at much less cost that does the work just as well as an expensive tool. You can see for yourself the great number of home-made 'kinks' around the shops and yard.

"We take our men and foremen through the storehouse and show them how we keep books and what the material they are using costs. You don't see any men splitting nuts or breaking globe valves now, for they know what a new one costs and are anxious to help save money. Spoiled work is followed up closely, for that is one of the most expensive items on a railroad. When we find a careless workman that spoils

a lot of jobs, he is asked to get out, for we can't afford to have him around.

ECONOMY COMMITTEES

"Each department has its economy committee, composed of the regular workmen in that department, for we find that some men feel more free to talk and offer suggestions to their brother workmen than to the 'boss.' This committee has made some valuable suggestions, and as we offer a cash prize to any one who gets up a tool, or money-saving idea, we are getting the loyal support of every man.

"Take, for instance, the subject of keeping windows around the shop in good shape. It used to cost us an average of \$25 a month to keep new window glass in the frames, but the man who did the work got interested in the saving idea and showed us that by moving a few machines we could reduce the number of broken window glass. Our average cost per month now is under \$4, so you see that no matter what a man does, there is some chance for him to use his eyes.

"We had a machinist tell us that he lost about 25 per cent of his time waiting for his machine to stop after the power was shut off. You see, he was operating a high speed machine, and when we checked up his work we found that what he said was true, for he was on small work and had to start and stop his machine frequently. Another workman designed a simple brake by putting a short piece of belting over one of the steps on the cone pulley on the machine.

"One of our old drill press hands recommended that we place barrels of soapy water at convenient places in the shop to be used for drilling and cutting compound. We gave this job to an old employee, and he is more than saving his wages every month by keeping the barrels full. We not only save money on this material, but as it is so near the work, the men save steps and time in getting it.

"Another workman suggested that we use pieces of wrought iron pipe at several places in the plant where we were using rubber hose. This meant quite a saving in rubber hose, for after we installed the iron pipe we used shorter lengths of hose, and that gave us a supply of hose to last over eight months. In addition to putting in the iron pipe, that same workman has designed a flexible hose.

TRAINING A REAL EFFICIENCY ENGINEER

"And in conclusion," continued old Dan, "I know I am getting old, so instead of trying to take all the secrets of this plant to the grave with me, I am breaking in a bright young fellow to handle the place. In checking up the suggestions made by our workmen, I located this young man, and I have taken him into my office where I can train him to my ideas. The next time the vice-president or general manager wants to put in an efficiency engineer, I will have beaten him to it, for we have such a man now employed that I am training to my ideas, and even when I am through here, I will still be represented."

TAKE A REAL INTEREST IN THE APPRENTICE *

BY A. MacCORKINDALE

Foreman, Meadows Shops, Pennsylvania Railroad, Jersey City, N. J.

"How about the apprentices in your shop?" In our shops every encouragement is offered to employes having eligible sons anxious to learn a trade. Investigation is made concerning the general make-up of the candidate and his intentions, not forgetting his educational tendencies. Before he is hired every necessary point of information is given him regarding the conditions under which he will have to work, his wages, etc.

"Are they given a fair chance?" Yes. And I answer without fear of contradiction. We must realize that the apprentice of to-day is the artisan of to-morrow. Our apprentices are not sent hither and thither with any Tom, Dick or Harry, but are

placed under the care of high-class mechanics, so that they are insured the best of practical mechanical examples.

"Do they receive systematic and adequate training in their trades?" They do, and it is not the fault of the Pennsylvania Railroad if an apprentice fails to grasp the efficient system of which he is a part. He is continually told that if there is anything he wishes to know regarding the machinery or the work, to ask until the correct information is given him.

"What help or encouragement do you give them? Our master mechanic considers it a very important attribute towards being a good mechanic that a young man should be clean morally in spite of the oft-told tales that the best mechanics are generally rummies. It often happens that the high school boy who filed his application three years ago has changed his ideas of spending his leisure time. He used to march down the shop ready to work at the blow of the whistle, giving out a hearty "Good morning, sir," whereas now we see him repeatedly rushing from the car to the shop and arriving at the office with hardly enough breath left to ask for his card, and before he regains his normal state remarking to a dozen fellows: "Gee, I am tired," or "That car's late every morning." We frequently make our presence felt with that stamp of fellow.

Personally I never allow a chance to pass where our apprentices may be benefited, whether along mechanical, athletic or social lines. I have been successful in enrolling all the eligible apprentices in the Pennsylvania educational courses which provide free first-class information necessary for promotion. I use many lunch hours talking with them on theoretical and practical subjects, especially in their particular trades. Our Y. M. C. A. holds lunch hour meetings throughout the winter and in the absence of a professional speaker at several of these I was selected to speak, taking such subjects as "The Value of Study," "Technical Knowledge," "Influence of Associates," etc.

The following is considered an excellent schedule for machinist apprentices:

12 months.....	Machine shop
12 months.....	Erecting shop
3 months.....	Drawing room
2 months.....	Tin shop
2 months.....	Boiler shop
2 months.....	Blacksmith shop
9 months.....	Roundhouse
6 months.....	Finishing in erecting shop

DEVICE FOR FORMING SILL STEPS

BY JOHN TREACY

Foreman, Smith Shop, Great Northern, St. Paul, Minn.

A combination die is in use at this point for bending and twisting the ends of sill steps cold, which performs both opera-

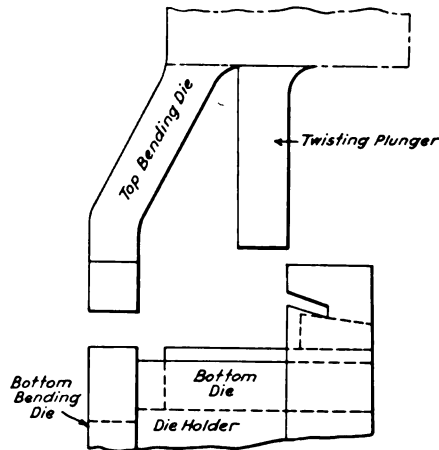

Relative Positions of the Bending and Twisting Dies

tions without the changing of dies. From the photograph it will be seen that there are two plungers, one to twist the ends of the material and the other to form the step. The lower twisting die is fitted with a slotted holder at one end

*Entered in the competition on "How Can I Help the Apprentice?" which closed September 1.

which prevents the end of the material from twisting, the remainder of the piece being supported on the die for about one-third of its width. The twisting plunger in its descent comes in contact with about one-half the width of the unsupported portion of the material. The piece is thus turned between the two dies to a right angle with the end in the grooved holder. After one end is twisted the material is reversed and the other end twisted in the same manner. The sketch is an end view of the device, showing the relative positions of the two plungers, both of which are attached to the same head. The plunger

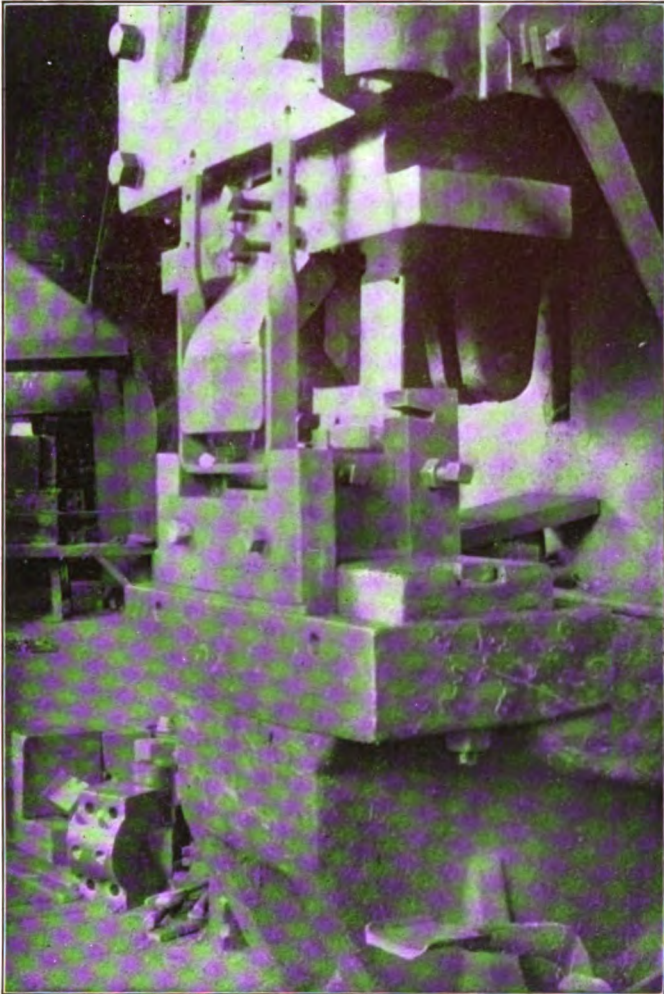

Dies for Twisting and Bending Sill Steps

which forms the step is in front of the twisting plunger and its operation will be readily understood from the illustrations.

The iron is received in the blacksmith shop from the company's own rolling mill at St. Cloud, Minn., where it has been cut to length. It is delivered by the stores department and piled beside the machine within convenient reach of the operator. Each piece is placed in the grooved holder and moved along until the end strikes a gage which fixes the length of the twisted portion. After the pieces are twisted the steps are formed on the same machine, the use of a plunger to twist the ends making it unnecessary to change dies between the two operations. This device has greatly increased the output of sill steps and has materially reduced the cost.

IGNITION TEMPERATURE OF COAL DUST.—Coal dust ignites at temperatures about 750 deg. F., provided there is enough heat present to ignite a sufficient quantity for passing along the heat of combustion to adjacent particles so as to make the ignition continuous.—*Power.*

HOW CAN I HELP THE APPRENTICE?*

BY J. H. PITARD

Master Car Painter, Mobile & Ohio, Whistler, Ala.

Make an intelligent selection of material. Before a boy essays to learn a trade, he should have a fairly good common school education. This is necessary for the development of the mind to the extent that will enable a boy quickly to grasp shop practice problems as they arise. A boy's general appearance and deportment should also be considered, and his acceptance should be decided on only after the foreman has satisfied himself that the applicant combines in a satisfactory degree the necessary qualities of an apprentice.

The advent of the apprentice into the shop means to him the opening up of a new world, and naturally he is more or less timid and credulous. At this point his foreman, in the privacy of his office, should have a heart to heart talk with him, and in a general way outline the work that lies before him and endeavor to impress him with the necessity of being studious and attentive to his duties; also of being self-reliant, self-respecting and respectful to his foreman and shop associates. Be his real friend, and the boy will be impressed. The foreman should give him all the encouragement possible, and care should be taken that, under no circumstances, should the boy become "cowed." With a broken spirited boy progress is correspondingly slow. Rather encourage him to believe in himself—the stronger the better. This is a necessary trait, which when once acquired, will stand him in good stead throughout his entire life.

Nurse him as little as possible. He should be placed on his own resources as fast as his attainments will warrant. The custom of the mother eagle in pushing her brood over the precipice as soon as their wings will sustain their weight contains a lesson which, in a large measure, is applicable in the case of an apprentice.

Put him through the different stages of the work in proper order. He should not be permitted to take up the first part last, nor the last part first. He should be required to proceed in the same order that obtains in constructive procedure, and should be held at each stage of the work until he has mastered it thoroughly, both in principle and practice.

Prepare written questions bearing on the most essential points of the work as he passes from stage to stage. Require written replies, which should be corrected, and the errors explained in detail. By this means the depth of his comprehension can be gaged, and the proper instructions given on the points most needed.

Relieve him of shop drudgery that has no bearing on his trade, but properly belongs to the common laborer or shop sweeper.

Give him due praise when his work merits it, and administer needed reproof in a manner that corrects, but leaves no sting.

Do not forget that he is still a boy with all the characteristics of a boy, for which allowance should be made. The occasional demonstrations of a boy's surplus energy, although not altogether consistent with shop discipline, should not meet with reproof too severe; such energy should be utilized by directing it into useful and proper channels.

Show a friendly interest in the boy's home and private life. Get in touch with his parents or guardian, if possible, and cooperate with them in every way that is beneficial to the boy's upbuilding and welfare.

LOCATING FLAWS IN METAL SURFACES.—Cracks or flaws in a smooth metallic surface are rendered visible by thoroughly moistening the surface with kerosene and then rubbing and drying it with a clean cloth and subsequently rubbing over the surface with chalk. The location of flaws will then be revealed by traces of the kerosene coming out again from the cracks into the chalk surfacing.—*Power.*

* Entered in the competition on "How Can I Help the Apprentice?" which closed September 1.

NEW DEVICES

PISTON VALVE WITH AUTOMATIC CUT-OFF FOR AIR COMPRESSORS

The slide steam valve in various forms has been standard on air compressor units below the sizes (about 25-in. stroke), where the use of the Corliss valve gear becomes commercially practicable. But the wider use of high pressure and superheated steam has made the use of the slide valve, even of the adjustable cut-off type, obsolete. At high temperatures it is very

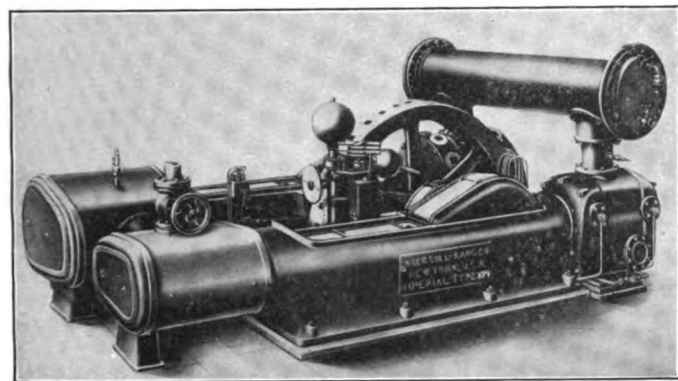

Air Compressor with Piston Valves and Automatic Cut-Off Valves

unsatisfactory, due to its tendency to warp, with consequent leakage, and the difficulty of lubrication is also increased, which results in greater wear and greater force required to drive the valve. To provide a steam-driven air compressor which will operate satisfactorily with high pressures and superheat, as well as with moderate pressures, the Ingersoll-Rand Company, New York, has developed a balanced piston valve, which has been

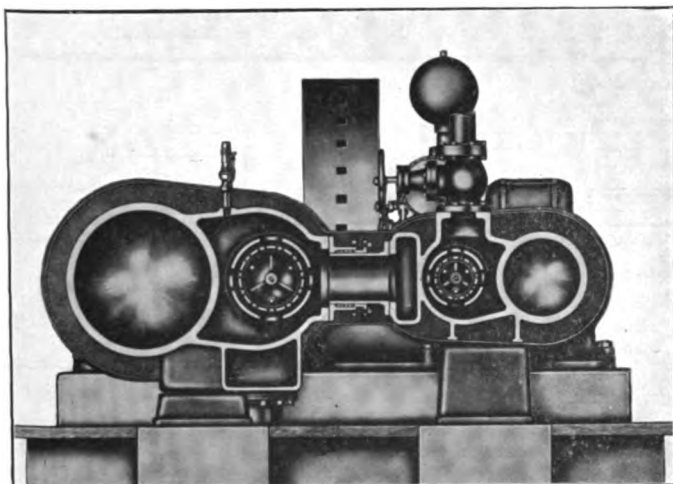

Cross Section Through Cylinders, Valve Chambers and Receiver, Ingersoll-Rand Piston Valve Air Compressor

incorporated in the design of its line of standard Imperial duplex air compressors.

The use of a balanced valve makes it possible to control the machine by automatically varying the point of cut-off in the steam cylinders. This method of regulation maintains constant speed for changing steam pressures and at the same time varies the speed of operation to the demand for air. Steam is

always admitted to the steam cylinder at full boiler pressure and without the wire drawing of a governor of the throttling type. With the hand-adjusted cut-off valves, usually set at $\frac{5}{8}$ or $\frac{3}{4}$ stroke, the steam economy is admittedly poor, while with an automatic cut-off regulation a considerable saving in actual steam consumption is effected.

This piston valve is a perfectly balanced valve of the telescopic type. The cut-off valves are right and left-hand threaded to a cut-off valve stem, which enters the valve chamber and the valve through the center of the valve stem. Steam admission is through the center of the valve, the steam then passing through the valve ports to the cylinder and being exhausted by the ends of the valve. It should be noted that this construction exposes the valve chest covers and steam packings to exhaust pressure only, thus reducing the liability of leakage. The design and uniform distribution of metal in this piston valve are claimed to preclude any possibility of warping and to result in a valve so balanced that friction is minimized and lubrication facilitated.

The steam ports are large and unusually direct and special effort has been made to reduce the condensation surfaces in the cylinders. Exceptionally complete insulation, the separa-

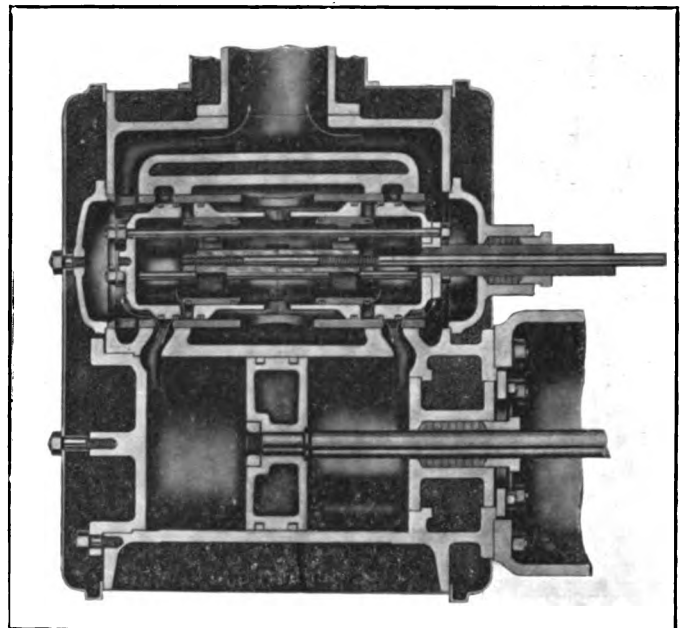

Longitudinal Section Showing Balanced Piston Valve and Cut-Off Valves, Ingersoll-Rand Compressor

tion of live and exhaust steam passages and the fact that the steam chest partially encircles the cylinder, contribute to the steam economy. These features are clearly shown in the sectional illustrations. The cylinder and receiver lagging is covered with a sheet iron casing and that of the cylinder heads with neatly fitting cast covers.

The steam receiver is a direct connection between the high and low pressure steam chests. The low pressure chest is proportioned to furnish additional capacity and so located that the heat ordinarily lost by radiation is used in heating the cylinder and valve. A special expansion joint prevents any possibility of cylinder alignment being destroyed.

The governor is a speed and pressure regulator, which varies the cut-off by automatically rotating the cut-off valve stem

and changing the relative position of the cut-off valves. It is essentially a chain-driven rotary oil pump, which acts against a weighted plunger. The variation in oil pressure due to the changing speed of the compressor, or the varying air pressure acting against the plunger, changes the cut-off point in the steam cylinders.

This governor is entirely automatic in operation and is claimed to be capable of maintaining exceptionally reliable and close regulation.

Lubrication of both air and steam cylinders and valves is provided for by force feed oilers. The compressor of the new design, called the Imperial type XPV, are similar to those now in service, built by the same company. They include a wholly enclosed main frame containing the reciprocating parts, automatic lubrication by the bath system and completely water-jacketed air cylinders. They are built in capacities from 608 to 3,620 cu. ft. per minute and for discharge air pressures from 10 to 110 lb. per sq. in.

MANUAL SLACK ADJUSTER FOR FREIGHT CARS

A manually operated slack adjuster for use on freight equipment has recently been placed on the market by the H. W. Johns-Manville Company, New York. The purpose of the device is to make it unnecessary to crawl under each truck in order to take up slack due to brake shoe wear, a task both dangerous and difficult of performance. The device is located in the

of the double yoke fit into grooves in the side of the body, thus holding the end of the yoke in position and guiding the relative movement of the two parts. The jaw at the open end of the body is closed by a block of rectangular section on the end of a thrust rod, the upper and lower faces of this block serving as a guide for the open end of the double yoke. The thrust rod, which is about 9 in. long, extends back on the center line of the body, and passes through the cored hole in the throat of the double yoke.

Within the closed part of the yoke are placed 12 thrust blocks, each one-half in. thick. The width of the opening between the sides of the yoke is increased at the throat to permit the passage of the retaining lugs on the ends of these blocks. A key block is inserted in this opening when the device is assembled and is locked by the thrust rod, which passes through a hole in the block. The thrust blocks have a length of 3 in. between the retaining lugs and through the lower end of each is a hole $1\frac{1}{8}$ in. in diameter. When the blocks are raised until the lugs on the lower ends are brought in contact with the yoke these holes are in line with the thrust rod, thus permitting the yoke to be moved to the position shown by the broken lines in the drawing.

When slack is to be adjusted, the brakes are set lightly in order to show the piston travel. A pinion secured to the body meshes with a rack on one side of the yoke. By inserting a short bar in the capstan head of the pin which holds the pinion in place, the yoke may be moved back, thus shortening the length of the cylinder tie rod. As soon as the rod has been shortened one-half inch one of the thrust blocks will be released from the end of the thrust rod and will drop to its lower position by

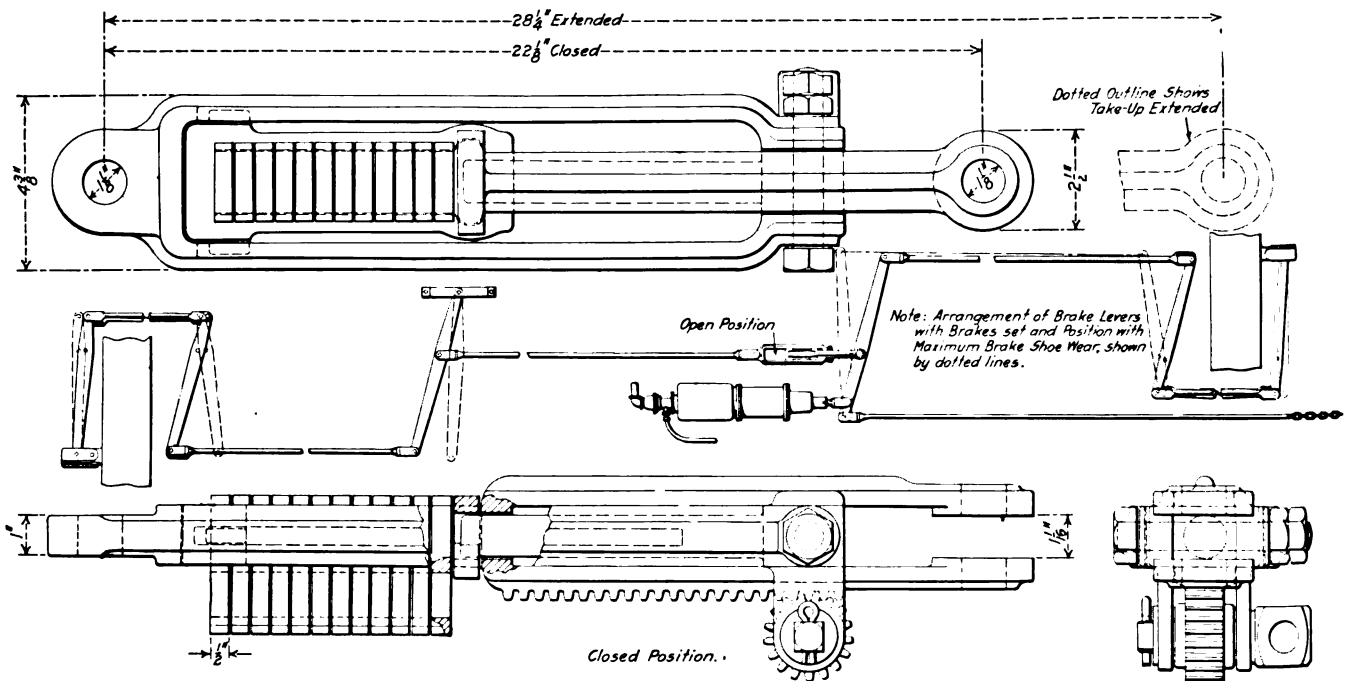

Manually Operated Slack Adjuster

cylinder tie rod, where it is easily accessible, and but one adjustment is necessary for both trucks. The adjustment is made when the brakes are applied lightly so that correct piston travel may be obtained without trial adjustments.

The location of the device in the brake rigging as well as its construction are shown in the drawing. Adjustment is effected between the body of the device and a double yoke sliding within the body. The body is a malleable iron casting about 18 in. long of yoke form, the closed end being provided with a tongue which is connected to the end of the tie rod. The double yoke consists of two parts, the sides of which are turned at right angles to each other. These two parts join at a throat through which is cored a hole $1\frac{1}{8}$ in. in diameter. Lugs on the inner end

gravity. The other blocks follow successively for each succeeding one-half inch adjustment. In the lower position the solid portion of the block is opposed to the end of the thrust rod, thus preventing the return of the parts to the original position. The adjustment is continued till the piston travel has been shortened to standard. The total adjustment of 6 in. in the length of the rod provided by the device is sufficient to take care of maximum brake shoe wear.

SCRAP IN A POWER HOUSE.—A Chicago wrecking company recently salvaged about 2,000 tons of old iron and steel by the tearing down of the power house of the Philadelphia Rapid Transit Company.—Power.

COMPRESSED AIR GREASE CUPS

A grease cup depending partially upon the action of compressed air to automatically feed the grease, has been developed by the Hunter Pressed Steel Company, Philadelphia, Pa. The device is designed primarily for use in stationary practice where it is claimed to require but little attention, adjustment once a week often being sufficient.

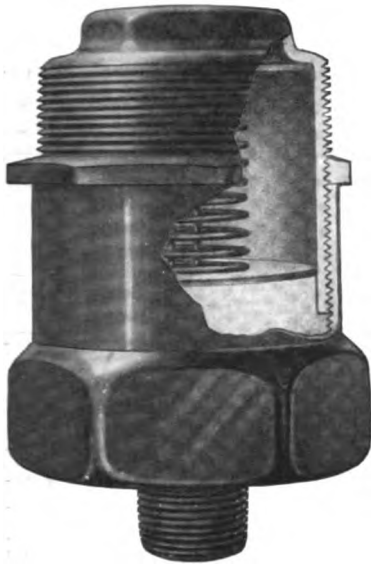

Construction of the Airspring Grease Cup

The device is manufactured from pressed steel and consists of the ordinary type of grease cup threaded on the inside, into which a light pressed steel cap is screwed. Within the cap is a light coil spring and flat disc which is pressed down upon the top of the grease and supplements the air pressure as well as serving to level the grease and distribute the pressure when first applying the cap. The air entrapped within the cap is compressed as the cap is screwed into place and sealed within the grease, and the action is entirely automatic. The disc and spring are easily removable from the cap and are reversible, it thus being impossible to improperly assemble the device. The cup is known as the Airspring Grease Cup and is furnished in four sizes for 1/2 oz., 1 oz., 3 oz., or 6 oz. of grease.

CAST STEEL TRUCK SIDE FRAME

The drawing shows a recently developed cast steel truck side frame which has been adopted by the Pennsylvania Railroad. The

The distribution of metal has been carefully considered and a well balanced structure obtained, effecting a uniformity of flexibility under the action of the stresses due to both static and dynamic vertical loading.

Where unbalanced sections are used in the design of cast steel truck frames, the unequal strains set up in the metal, in cooling, result in a distortion of the casting. This distortion is corrected by placing the casting when cool under the straightening press, the result being that the metal at certain points is subjected to a stress beyond the elastic limit. Certain weak points are, therefore, developed in the casting at the outset, their strength being very uncertain. Cracks tend to start at these points, which result in the ultimate failure of the casting. The symmetrical and well balanced design of the Benners side frame is such that the castings come out of the sand in perfect shape and the use of the straightening press is entirely unnecessary.

The Benners frame has no outwardly extending flanges, such as are found in castings of angular or I-sections, which always tend to develop cracks at the edges. The use of re-entrant flanges brings the edge of the material nearer the neutral axis of the section, a point where the unit stress is considerably reduced.

After thorough tests of the Benners side frame, it has been adopted by the Pennsylvania Railroad and the Pennsylvania Lines West, now being in service under several thousand freight cars. The patents are controlled by Edward H. Benners, 50 Church Street, New York.

STRENGTH OF AUTOGENOUS JOINTS.—The strength of the joint produced by autogenous welding, it is pointed out in a paper on high-temperature flames in metal working, has been a fruitful source of discussion in the application of the process, and many contentions have been advanced as to the necessity of welds of highest tensile strength. It was early found that 100 per cent welds, or, in other words, those having a breaking strength equivalent to that of the metal itself, could be produced, but the sacrifice of elongation and reduction of area materially lessened the apparent value of such welds. Present practice is directed toward securing a weld of good tensile strength, as compared with the strength of the plate, with high ductility, since thereby the service conditions are better fulfilled. The growth in under-

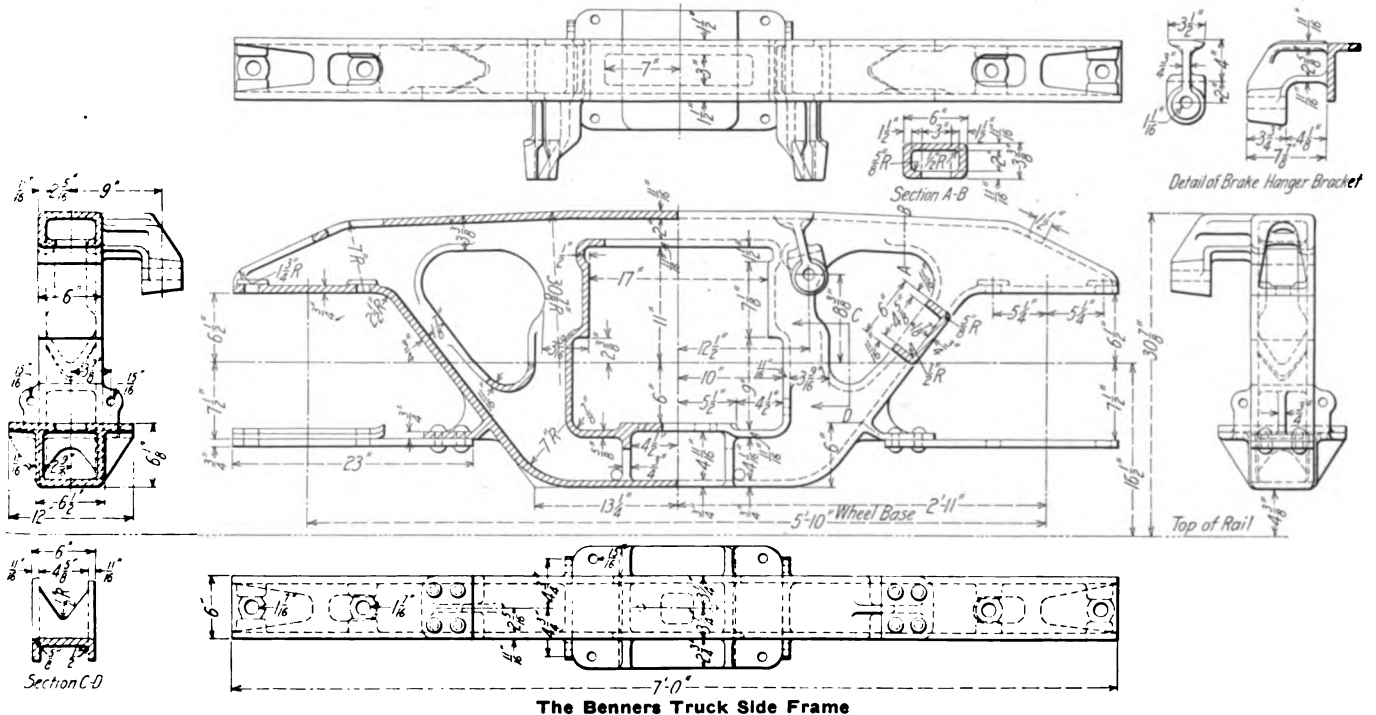

The Benners Truck Side Frame

principal feature of the design is the use of channel sections and channels with re-entrant flanges instead of angle and I-sections.

standing of such requirements has resulted in the production of methods which produce these results.—*American Machinist.*

NEWS DEPARTMENT

The shops and roundhouse of the Chicago & Illinois Midland at Taylorville, Ill., were destroyed by fire November 4; loss \$65,000.

The shops of the Norfolk Southern at Newbern, N. C., were destroyed by fire on November 16; loss, \$200,000. Two locomotives were damaged and several freight cars were burnt up.

James J. Hill, in honor of whom a number of men have founded a professorship of transportation in the Graduate School of Business Administration, of Harvard University, has given to the university \$125,000, to be added to the like sum which was given by the founders.

The Nashville, Chattanooga & St. Louis reports that its expenses for clearing wrecks in the last fiscal year amounted to only \$6,521, which is equal to 59 cents out of every \$1,000 revenue received. Taking the records of all the railroads in the southern group, it appears that the average cost of clearing wrecks was \$2.40 to every \$1,000 gross revenue.

The eastern associations of general chairmen of the Brotherhood of Locomotive Engineers and the Brotherhood of Locomotive Firemen and Enginemen, in a joint session at Cleveland on November 17, decided to join the Brotherhood of Railroad Trainmen and the Order of Railway Conductors in their campaign for an 8-hour day and time and a half for overtime. It is said that formal action on this movement is to be taken at a meeting of the executive committee of the four brotherhoods at Chicago on December 15, when the formal ballot for a referendum vote of all of the members of the organization will be prepared.

General Manager Robert S. Parsons of the Erie Lines West has issued to enginemen a circular which, according to the *Cleveland Leader*, includes the following:

"If you were a passenger seated at a car window, or sleeping in a berth, you would not like to have a locomotive whistle blown just opposite you, giving you a severe attack of the 'jumps.'

"If you were a passenger you would not like to have the train come to a stop with a jolt rough enough to break the articles in your traveling bag and give you a general shaking up.

"Yet these annoyances occur every day, and many times a day, on the Erie Railroad—all because you do not realize the situation in which the passengers are placed. There is no rule or regulation that can stop these practices. It rests entirely upon your good nature and thoughtfulness. Will you strive to make an improvement?"

The Baltimore & Ohio has issued for its employees a treatise on first aid to the injured prepared by Dr. Joseph F. Tearney, chief medical examiner of the road. Discussing the effect of alcoholic liquors given in connection with sickness or accident, Dr. Tearney says: "Whiskey, even in small teaspoonful doses, increases the tendency to bleeding. When given in the somewhat larger quantity, known as the ordinary 'drink,' the first effect of

stimulation is followed by a corresponding depression, so that, when the surgeon arrives, he will have to lose valuable time in combating this depression, in addition to that caused by the shock of the accident. . . . If the sympathetic friend with the bottle tries to deaden pain with whiskey, he may produce intoxication and it is difficult to put a half-drunken man under an anaesthetic. It may be asked why the surgeon sometimes gives whiskey; the answer is that he knows how much to use and when not to use any. . . . Make it your iron-bound rule to allow the patient to have no whiskey or other alcoholic liquors."

THE EMPIRE STATE EXPRESS

This famous train of the New York Central, the first regular long distance train in America to run at over 50 miles an hour, including stops, has begun its twenty-fifth year. It has covered a distance of 6,518,600 miles, equal to 14 round trips to the moon, and has carried approximately 8,000,000 passengers safely to their destinations. The record during these 24 years has been a remarkable one. Not one of its passengers has been fatally injured. One of its enginemen for sixteen years was Dennis J. Cassin, who last year was awarded the Harriman bronze medal in recognition of his unblemished record of safety.

When the Empire State Express was first placed in service it weighed only 230 tons; now it weighs 780 tons. It was drawn by engines of the "870" class, and later by the famous "999," the locomotive that took the prize at the Chicago World's Fair. Nowadays that locomotive looks like a toy in comparison with the giant Pacific type, and it could hardly start the train, much less haul it on its fast schedule.

CAR AND LOCOMOTIVE ORDERS IN NOVEMBER

During the month of November, orders for locomotives, freight cars and passenger cars were reported as follows:

	Locomotives.	Freight Cars.	Passenger Cars.
Domestic	200	13,700	327
Foreign	6	1,000	...
Total	206	14,700	327

Among the more important orders for locomotives were the following: Elgin, Joliet & Eastern, 18 Mikado and 9 switching locomotives, American Locomotive Company; Baltimore & Ohio, 14 Mallet type locomotives, Baldwin Locomotive Works, and 15 of the same type, American Locomotive Company; New York, New Haven & Hartford, 33 Mikado type locomotives, American Locomotive Company, and the Pennsylvania Lines West, 48 Consolidation locomotives, American Locomotive Company, and 15 of the same type, Lima Locomotive Corporation.

The New York Central was reported in last month's issue, page 599, as having ordered 9,000 freight cars. During November additional New York Central orders were reported, aggregating 3,000 cars. Of these, 2,000 were for the New York Central itself, orders having been reported as follows: Pressed

RAILROAD CLUB MEETINGS

Club	Next Meeting	Title of Paper	Author	Secretary	Address
Canadian.....	Dec. 11.....	Pure Iron and Its Use by Railway Companies.....	J. T. Hay.....	James Powell.....	St. Lambert, Que.
Central.....	Dec. 10.....	Harry D. Vought.....	95 Liberty Street, New York
New England.....	Dec. 14.....	Efficiency in Track Work.....	S. L. Connor.....	Wm. Cade, Jr.....	683 Atlantic Avenue, Boston, Mass.
New York.....	Dec. 17.....	Annual Meeting.....	Harry D. Vought.....	95 Liberty Street, New York
Pittsburgh.....	Dec. 21.....	The Life of the Steel Freight Car.....	S. Lynn.....	J. B. Anderson.....	207 Penn Station, Pittsburgh, Pa.
Richmond.....	Dec. 13.....	Moving Pictures National Tube Company.....	C. F. Roland.....	F. O. Robinson.....	C. & O. Ry., Richmond, Va.
St. Louis.....	Dec. 10.....	Annual Meeting.....	B. W. Frauenthal.....	Union Station, St. Louis, Mo.
South'n & S'w'n.....	A. J. Merrill.....	Box 1205, Atlanta, Ga.
Western.....	Jos. W. Taylor.....	1112 Karpen Bldg., Chicago, Ill.
Western Canada.....	Louis Kon.....	Box 1707, Winneg, Man.

Steel Car Company, 500 gondola cars; Standard Steel Car Company, 500 gondola cars; Haskell & Barker Car Company, 500 box cars, and the American Car & Foundry Company, 500 box cars. The other 1,000 cars were hopper cars ordered from the Standard Steel Car Company for the Pittsburgh & Lake Erie. Among other important orders were: The Western Maryland, 1,000 additional hopper cars, Pullman Company; the Western Pacific, 1,000 box cars, Pullman Company; the Chesapeake & Ohio, 2,000 coal cars, Standard Steel Car Company, and the Central of New Jersey, 1,000 hopper cars, Standard Steel Car Company, 500 box cars, Standard Steel Car Company, and 750 box cars, American Car & Foundry Company.

The largest passenger car order reported during the month was that placed by the Interborough Rapid Transit Company of New York with the Pullman Company for 234 motor car bodies and 77 trailer car bodies for the company's new rapid transit lines. The Philadelphia & Reading ordered 20 coaches and 10 combination cars from the Harlan & Hollingsworth Corporation.

MEETINGS AND CONVENTIONS

American Society of Mechanical Engineers.—The annual meeting of the American Society of Mechanical Engineers will be held at the Engineering Societies' building, 29 West Thirty-ninth street, New York City, on December 8, 9 and 10, 1915. The railroad session will be held on Wednesday afternoon, December 8. The subcommittee on railroads has endeavored to provide a program of unusual interest, and papers will be presented dealing with both locomotives and cars. The papers were announced in last month's issue.

June Mechanical Conventions.—The meeting of the executive committee of the Master Car Builders' Association, the American Railway Master Mechanics' Association and the Railway Supply Manufacturers' Association was held in Chicago on November 15. It was decided that the next annual convention of the Master Car Builders' and the Master Mechanics' Associations would be held at Atlantic City, starting June 14, the Master Car Builders' convention being held first and the Master Mechanics' convention the following Monday. The city of Chicago would undoubtedly have been chosen as the convention meeting place had the Municipal Pier been ready for occupancy at that time. It is believed that in future years the June conventions will be held at that place.

The following list gives names of secretaries, dates of next or regular meetings and places of meeting of mechanical associations:

- AIR BRAKE ASSOCIATION.—F. M. Nellis, 53 State St., Boston, Mass.
 AMERICAN RAILROAD MASTER TINNERS', COPPERSMITHS' AND PIPEFITTERS' ASSOCIATION.—W. E. Jones, C. & N. W., 3814 Fulton St., Chicago.
 AMERICAN RAILWAY MASTER MECHANICS' ASSOCIATION.—J. W. Taylor, Karpen Building, Chicago.
 AMERICAN RAILWAY TOOL FOREMEN'S ASSOCIATION.—Owen D. Kinsey, Illinois Central, Chicago.
 AMERICAN SOCIETY FOR TESTING MATERIALS.—Prof. E. Marburg, University of Pennsylvania, Philadelphia, Pa.
 AMERICAN SOCIETY OF MECHANICAL ENGINEERS.—Calvin W. Rice, 29 W. Thirty-ninth St., New York. Annual meeting, December 7-10, 1915, New York.
 ASSOCIATION OF RAILWAY ELECTRICAL ENGINEERS.—Joseph A. Andreucetti, C. & N. W., Room 411, C. & N. W. Station, Chicago.
 CAR FOREMEN'S ASSOCIATION OF CHICAGO.—Aaron Kline, 841 North Fifth Street, Chicago. Second Monday in month, except July and August, Lytton Building, Chicago.
 CHIEF INTERCHANGE CAR INSPECTORS' AND CAR FOREMEN'S ASSOCIATION.—W. R. McMunn, New York Central, Albany, N. Y.
 INTERNATIONAL RAILWAY FUEL ASSOCIATION.—C. G. Hall, 922 McCormick Building, Chicago.
 INTERNATIONAL RAILWAY GENERAL FOREMEN'S ASSOCIATION.—William Hall, 1126 W. Broadway, Winona, Minn.
 INTERNATIONAL RAILROAD MASTER BLACKSMITHS' ASSOCIATION.—A. L. Woodworth, Lima, Ohio.
 MASTER BOILER MAKERS' ASSOCIATION.—Henry D. Vought, 95 Liberty St., New York.
 MASTER CAR BUILDERS' ASSOCIATION.—J. W. Taylor, Karpen Building, Chicago.
 MASTER CAR AND LOCOMOTIVE PAINTERS' ASSOCIATION OF U. S. AND CANADA.—A. P. Dane, B. & M., Reading, Mass.
 NIAGARA FRONTIER CAR MEN'S ASSOCIATION.—E. Frankenger, 623 Brisbane Building, Buffalo, N. Y. Meetings monthly.
 RAILWAY STOREKEEPERS' ASSOCIATION.—J. P. Murphy, Box C, Collinwood, Ohio.
 TRAVELING ENGINEERS' ASSOCIATION.—W. O. Thompson, N. Y. C. R. R., East Buffalo, N. Y.

PERSONALS

GENERAL

R. A. BILLINGHAM, master mechanic of the Tennessee Central, at Nashville, Tenn., has been appointed mechanical superintendent, and the office of master mechanic has been abolished.

H. W. CATHCART has been appointed assistant fuel and locomotive inspector of the Philadelphia & Reading at Reading, Pa.

M. E. HAMILTON, northwest railroad representative of the Garlock Packing Company, with headquarters at St. Paul, Minn., has been appointed general air brake inspector of the St. Louis & San Francisco. Mr. Hamilton was formerly general air brake instructor on the Atchison, Topeka & Santa Fe.

T. E. HESSENBRUCH has been appointed fuel and locomotive inspector of the Philadelphia & Reading at Reading, Pa.

MASTER MECHANICS AND ROAD FOREMEN OF ENGINES

J. W. BAUM, general foreman of the Lake Erie, Franklin & Clarion, at Clarion, Pa., has been appointed master mechanic, and the position of general foreman has been abolished.

H. A. ENGLISH has been appointed master mechanic of the Canadian Northern, Central division, with headquarters at Winnipeg, Man., succeeding G. H. Hedge, promoted.

E. E. KEYSER has been appointed assistant road foreman of engines of the third and fourth divisions, Virginian Railway, at Princeton, W. Va.

B. E. NEVINS has been appointed road foreman of engines of the first and second divisions, Virginian Railway, at Victoria, Va.

C. J. QUANTIC has been appointed master mechanic of the Canadian Northern, Pacific division, at Port Mann, B. C.

F. RONALDSON, formerly locomotive foreman of the Canadian Pacific at Lambton, Ont., has been appointed district master mechanic at Farnham, Que., succeeding H. Pepler.

CAR DEPARTMENT

H. J. WHITE has been appointed supervisor of car work of the Canadian Northern, eastern lines. Mr. White was born in Brownington, Vermont, April 1, 1871. He commenced railway work in May, 1893, as car repairer and joint car inspector for the Boston & Maine and the Canadian Pacific at Newport, Vermont, which position he held till September, 1894, when he was transferred to St. Polycarpe Junction as joint car inspector for the Canadian Pacific and Canada Atlantic (now part of the Grand Trunk Railway system). In May, 1900, he became car inspector for the Canadian Pacific at Parkdale, being transferred in November of the same year to Union Yards, Toronto, in the same capacity, where he remained until February, 1903. He was then made leading hand carpenter at the Canadian Pacific car shops at Outremont. In September, 1906, he became car foreman and wrecking foreman of the Ca-



H. J. White

nadian Pacific at North Bay, later being transferred to the West Toronto shops as general foreman. In November, 1913, he was appointed general foreman, car department of the Quebec Grand Division of the Canadian Northern, which position was held until his recent appointment, as noted above.

W. E. GROVE has been appointed assistant general car inspector of the Philadelphia & Reading at Reading, Pa.

W. H. PIERIE, formerly charge hand, has been appointed car foreman in the shops of the Intercolonial at Halifax, N. S., succeeding D. W. Murray, assigned to other duties.

SHOP AND ENGINE HOUSE

W. L. Kinsell, chief clerk to David Van Alstyne, assistant to the vice-president of the New York, New Haven & Hartford, has been appointed assistant shop superintendent at Readville, Mass.

PURCHASING AND STOREKEEPING

H. W. BOWEN has been appointed assistant storekeeper of the Baltimore & Ohio at Locust Point, Baltimore, Md.

F. B. CALHOUN has been appointed division storekeeper of the Atchison, Topeka & Santa Fe, at Waynoka, Okla.

W. D. FRANCIS has been appointed assistant storekeeper of the Baltimore & Ohio at Cleveland, Ohio, succeeding C. H. Rothgary, who has been promoted.

J. HARVEY has been appointed storekeeper of the Canadian Pacific at Havelock, Ont., succeeding A. Dobson transferred.

W. M. HINKEY has been appointed storekeeper of the Baltimore & Ohio at Kuper, W. Va., succeeding F. C. Winter.

James L. Woods has been appointed purchasing agent of the Nashville, Chattanooga & St. Louis with headquarters at Nashville, Tenn., succeeding A. C. Taylor, assigned to other duties.



J. L. Woods

1914, he served in various clerical capacities in the Atlanta freight agency at Atlanta, becoming chief clerk. From that position he was promoted to the position of assistant purchasing agent.

C. LAVENDER has been appointed storekeeper of the Canadian Pacific at John Street, Toronto, succeeding W. H. Bainbridge transferred.

C. H. ROTHGARY, assistant storekeeper of the Baltimore & Ohio at Cleveland, Ohio, has been appointed storekeeper at Lorain, Ohio, succeeding H. J. Cobb, resigned.

A. J. SWEING, chief clerk to the purchasing agent of the Wabash, has been appointed general storekeeper, with headquarters at St. Louis, Mo. This is a newly created office.

GEORGE G. YEOMANS has been appointed purchasing agent of the New York, New Haven & Hartford, with headquarters at Boston, Mass. Mr. Yeomans was born on January 11, 1860, at Trenton, N. J., and graduated from Princeton University. He began railway work in 1882, as rail inspector on the Chicago, Burlington & Quincy. From 1884 to 1886, he was a clerk in the purchasing department, and then to 1891, was chief clerk of the same department. From 1891 to March, 1898, he was assistant purchasing agent, and in March, 1898 was promoted to purchasing agent of the same system, remaining in that position until July, 1905. He served from July to October, 1905, as assistant to first vice-president of the Wabash Railroad and as assistant to president of the Wheeling & Lake Erie, the Wabash Pittsburg Terminal, the Pittsburg Terminal Railroad Coal Company and the West Side Belt. From October, 1905, to March, 1912, he was assistant to president of the same roads. Since then he has made a study of methods of purchasing and handling supplies on several roads.

OBITUARY

WILLIAM FREDERICK ALLEN, general secretary of the American Railway Association and its predecessors, since 1875, and manager of the Official Railway Guide since 1873, died on November



W. F. Allen

9 at his home in South Orange, N. J. Mr. Allen was one of the most widely known men in American railroad life. He was born October 9, 1846, at Bordentown, N. J., and received his education in the Bordentown Model School and the Episcopal Academy in Philadelphia. He began railway service in May, 1862, as a rodman in an engineering corps of the Camden & Amboy, becoming in May, 1863, assistant engineer of the same road. From February, 1868, to 1872, he was resident engineer of the West Jersey Railroad. In 1872 he entered the service of the National Railway Publication Company, and shortly afterwards was made assistant editor of the Official Railway Guide. In June, 1873, he became the editor and manager of the Guide, and has been at the head of it ever since. In April, 1875, he was appointed secretary of the General Time Convention and in October, 1877, of the Southern Railway Time Convention. In April, 1886, the American Railway Association succeeded these organizations and Mr. Allen continued as secretary, holding the position of general secretary and treasurer at the time of his death.

In 1910 Mr. Allen was elected vice-president of the National Railway Publication Company and since 1914 had been its president. At the time of his death he was also secretary of the General Managers' Association of New York and the Bureau for the Safe Transportation of Explosives.

In his capacity as secretary of the American Railway Association Mr. Allen has become intimately acquainted with a larger number of railway managers than any other man in the country. The presidency of the association has been held by different men, from different parts of the country, but the secretaryship has been a permanent feature, and his administration of the office has been an important element in the association's prosperity.

Outside the railroad world Mr. Allen was known chiefly as the "father of standard time." To him was referred for solution, in 1881, the problem of working out a standard of time reckoning

that would obviate the confusion resulting from the use of the fifty-odd standards then prevailing on the railroads in the United States. His report was submitted to the Association in 1883. It provided for an elastic boundary line between the hour zones, instead of a strictly longitudinal division; and in its details fixed every point at which the hour change was to be made, and embodied every practical provision for putting the system into immediate effect. The report was unanimously endorsed by the Association, and Mr. Allen thereupon accomplished the unique diplomatic task of securing its adoption by the numerous diverse interests whose approval was essential to success.

The change in the operating time tables of the many different railroads was made at noon, eastern time, on Sunday, November 18, 1883, without delay or disturbance. For this achievement Mr. Allen was elected to honorary membership in many American and foreign scientific societies, and received the honorary degree of master of science from Princeton University. Mr. Allen was a delegate of the United States Government to the International Meridian Conference in 1884, and to the International Railway Congress at Paris in 1900. He was a delegate of the American Railway Association to the International Railway Congresses at London, 1895; Paris, 1900; Washington, 1905; Berne, 1910. Since 1910 he has been a member of the Permanent Commission of the Congress Association.

In 1905 he had charge of all the arrangements for the session at Washington. For his services in this connection he was decorated with the order of Leopold by the Belgium Government.

JAMES F. DeVoy, assistant superintendent of motive power for the Chicago, Milwaukee & St. Paul, at Milwaukee, Wis., died at his home in that city on November 5, following an illness of eight months. He was born in Ithaca, N. Y., on June 23, 1866, and graduated from Cornell University in 1888. During his college career he won distinction not only as a football player and crew man, but as an honor student in the college of mechanical engineering. Following his graduation he entered the service of the New York Central in its mechanical department, where he remained for seven years. He was then employed by the American Locomotive Company both at Dunkirk, N. Y., and Schenectady. Fifteen years ago he came



J. F. DeVoy

to Milwaukee as chief draftsman in the mechanical department of the Chicago, Milwaukee & St. Paul. On September 1, 1902, he was promoted to mechanical engineer, and on April 15, 1910, he was appointed assistant superintendent of motive power. At the time of his death he was a member of the executive committee of the American Railway Master Mechanics' Association, a member of the committee on design, maintenance and operation of electric rolling stock, and also a member of the committee on brake shoes and brake beam equipment and the coupler committee of the Master Car Builders' Association. From 1910 to 1911, he was president of the Western Railway Club.

R. B. SALMON, master mechanic of the Louisville & Nashville at Covington, Ky., died on November 3, at Covington.

R. S. STEPHENS, until June 1, 1913, purchasing agent at Houston, Texas, for the Galveston, Harrisburg & San Antonio, the Houston & Texas Central, and the Texas & New Orleans, died at his home in Houston on November 2.

SUPPLY TRADE NOTES

Elmer B. Van Patten has been appointed sales representative of the Acme Supply Company, with headquarters at Chicago, Ill.

J. M. Spangler, formerly with the Railroad Supply Company, Chicago, has recently entered the service of the National Carbon Company, Cleveland, Ohio.

L. T. Burwell, formerly with the M. W. Supply Company, Philadelphia, Pa., has become associated with the Q & C Company, N. Y.

Frank R. Peters, formerly with J. Stone & Co., London, England, has joined the electrical staff of the Franklin Railway Supply Company, New York.

R. W. Burnett, for many years general master car builder of the Canadian Pacific, has been elected vice-president of the National Car Equipment Company, of Chicago, Ill.

C. B. Little, formerly an electrical engineer in the service of the Baltimore & Ohio, has resigned to enter the service of the Franklin Railway Supply Company, New York.

The Toledo Scale Company announces that H. O. Hem, formerly of Kansas City, Mo., has become a member of its engineering staff in the capacity of consulting engineer, and has opened an office at Toledo, Ohio.

G. C. Pool, formerly with Guilford S. Wood, Chicago, and previous to that with the Acme Supply Company, Chicago, has become connected with the Q & C Company, New York. His attention will be given particularly to Q & C devices for locomotives and cars.

Frederic H. Poor, who since the incorporation in December, 1909, of the S. K. F. Ball Bearing Company, of New York, has been its general manager, has recently severed his connection with that organization, and has opened an office of his own at 30 Church street, New York.

R. W. Gillispie, New York district sales manager of the Pennsylvania Steel Company, has been appointed general manager of sales, succeeding John C. Jay, Jr., who has resigned from his position as vice-president and general manager of sales to become chairman of the Maxwell Motor Company.

The Chicago Railway Signal & Supply Company opened two new branch offices, on October 15, one located at 407 Confederation building, Winnipeg, Man., and the other at 320 Kearns building, Salt Lake City, Utah. W. Reynolds will have charge of the company's Canadian interests, and C. H. Jones will act as representative for the western district, having Salt Lake City as its center.

The S. K. F. Ball Bearing Company, of Hartford, Conn., recently incorporated with a capital of \$2,000,000, to take over the business of the S. K. F. Ball Bearing Company, of New York, a house importing ball bearings made in Sweden, is about to erect a factory at Hartford, Conn. The new company has acquired the right to manufacture the S. K. F. ball bearings, formerly made in Sweden. Its directors are: Frank A. Vanderlip, of the National City Bank; B. M. W. Hanson, vice-president of Pratt & Whitney; Franklin B. Kirkbride, 7 Wall Street, New York; A. Carlander and S. Winguist, directors of the Swedish S. K. F. Company, which is a large holder in the new American corporation, and B. G. Prytz, who will act as president.

J. Leonard Replogle, vice-president and general manager of sales of the American Vanadium Company since March 1, 1915, and prior to that vice-president and general manager of sales of the Cambria Steel Company, on November 12, purchased from the Pennsylvania company approximately 240,000 shares of stock in the Cambria Company at a price of almost \$15,000,000. Mr.

Replegle's holdings do not give him control of the Cambria Steel Company. The latter is capitalized at \$50,000,000, of which \$45,000,000 is outstanding in shares of \$50 par value. The Pennsylvania Company (Pennsylvania Lines west of Pittsburgh) a short time ago held \$22,504,000 of this, or slightly over 51 per cent. It later sold \$98,000 shares in the open market and recently William H. Donner, president of the Pennsylvania and Cambria Steel Companies, exercised options for the purchase of 112,000 shares. It is understood that the syndicate for which Mr. Replegle is acting controls more than the 240,000 shares acquired from the Pennsylvania Company, but it is not believed that they have a majority control. Mr. Donner and H. C. Frick had been taking action leading to a possible merger of the Pennsylvania and Cambria Steel Companies.

Isaac M. Cate, a large stockholder, has renewed his attack on the organization and management of the American Locomotive Company by sending first to the directors and now to the other stockholders a 58-page printed letter reciting the findings of his accountants and other details. Mr. Cate attacked the management of the company in February, 1912, directing his efforts against Waldo H. Marshall, president, and a number of other officers particularly. The board authorized an inquiry of Mr. Cate's charges of mismanagement, waste and misconduct, but the report of the committee of inquiry did not support Mr. Cate. In September, 1914, Sylvanus L. Schoonmaker was elected chairman of the board. This appeased Mr. Cate for a time, but not for long. In his present letter Mr. Cate seeks to discount the ability of the present management of the company. Concerning its war orders, he says: "Those in your company who did not make automobiles at a profit or develop the superheater or build locomotives in competition with the Baldwins are not the men to extract profits from shrapnel shells. The contract for shells was taken on April 15, with everything laid out for speedy preparations. There have been nearly six months of preparation. If the production of shells is subject to such prodigious cost as my accountant finds pervades the organization it will not be possible to compete with other institutions."

Harry D. Rohman, who was recently appointed chief electrical engineer of the Franklin Railway Supply Company, New York, was born in Switzerland in 1883. Upon his graduation as an electrical engineer from the technical schools of Zurich, he entered the works of the Oerlikon Electrical Construction Company. There he was afforded an opportunity of combining a practical training with the theory of engineering, and in 1903 qualified as an electrical engineer, with experience in high and low tension and A. C. and D. C. work, especially electrical traction. Later he entered the service of J. Stone & Co., London, and gradually worked up through its various departments until in 1910 he was appointed chief of the testing and experimental departments. In April, 1914, he was appointed chief assistant electrical engineer, and held that position until October 1, 1915, when he entered the service of the Franklin Railway Supply Company as noted above. Mr. Rohman speaks several languages and has had an extensive experience in all European countries, including the Balkan States, in South Africa and the Belgian Congo.



H. D. Rohman

CATALOGS

CONDENSERS.—The Mesta Machine Company, Pittsburgh, Pa., has recently issued Bulletin R, dealing with the line of barometric condensers made by that company.

LOCOMOTIVE APPLIANCES.—The Franklin Railway Supply Company, New York, has recently issued Bulletin No. 166, describing and illustrating the Franklin automatic adjustable driving box wedge.

STORAGE BATTERIES.—Bulletin No. 12, recently issued by the General Lead Batteries Company, Newark, N. J., deals with the use of the hydrometer syringe made by that company and tells how to recharge batteries.

KEROSENE TORCHES.—The Hauck Manufacturing Company, Brooklyn, N. Y., has recently issued bulletin No. 60, entitled, *Saving Ways in Busy Shops*, dealing with the company's burners and furnaces for kerosene and other oil fuel. The booklet contains a number of illustrations of the various burners and others showing the work which may be done by them.

WATER SOFTENING.—The L. M. Booth Company, New York, has recently issued a bulletin relative to the company's type F water softeners. The booklet is attractively illustrated. It explains the operation of the softeners in detail, showing sectional views of the softeners at work. There are also given a number of views of typical installations.

SIMPLEX LETTERING TEMPLETS.—The Keuffel & Esser Company, New York, has issued a leaflet describing its transparent dylonite templets for lettering engineering and architectural drawings, etc. The templet contains two holes with perforations of different sizes by means of which the letters of the alphabet and numerals may be spaced correctly and outlined. Glass and Payzant pens suitable for use with these templets are also described.

CENTRIFUGAL PUMPS.—Catalog H-2, recently issued by the Lea-Courtenay Company, Newark, N. J., describes and illustrates the various types and sizes of Lea-Courtenay centrifugal pumps. The booklet, containing 64 pages, is divided into 12 chapters, dealing respectively with the care taken in the manufacture of this company's product and the characteristics of the pump. The booklet is profusely illustrated.

SAVING SET-UPS IN RAILROAD SHOPS.—This is the title of a booklet which has recently been issued by the Lucas Machine Tool Company, Cleveland, Ohio. The booklet relates particularly to the Lucas "Precision" boring, drilling and milling machine and aims to show wherein that machine is productive of efficiency in the railroad shop. The catalog is well illustrated and attractively gotten up.

STORAGE BATTERIES.—The Titan Storage Battery Company, Newark, N. J., has issued a very attractive catalog relative to the company's line of storage batteries. The booklet touches upon the company itself and its aims, and treats of Titan storage batteries under the following heads: storage battery parts; elementary theory of the storage battery; Titan pasted plates, measurements, etc. Colored illustrations are given of the batteries and their parts.

IRON PIPE.—The A. M. Byers Company has recently issued Bulletin No. 26, dealing with the excellencies of Byers genuine wrought iron black and galvanized tubing, casing, line pipe and drive pipe. The bulletin contains considerable useful information about Byers pipe, such as its resistance to corrosion, fabricating qualities, welding qualities, specifications for genuine wrought iron pipe and details about hand puddling, rolling of muck bar, skelp, etc. In the back of the book are complete tables showing not only list prices, but dimensions, areas, hydrostatic tests, etc. There are also given specific cases showing the superior rust resistance of Byers in the same service with cheaper grades of pipe.

Railway Age Gazette

MECHANICAL EDITION

INCLUDING THE
AMERICAN ENGINEER

VOLUME 89—NUMBER 1

ESTABLISHED IN 1832

NEW YORK: Woolworth Bldg.
CHICAGO: Transportation Bldg.

NEW YORK—JANUARY, 1915—CHICAGO

CLEVELAND: Citizens Bldg.
LONDON (ENG.): Westminster



Schmidt Superheaters

mean the production of increased hauling power, the conservation of fuel and water, better steaming engines and the economic maintenance of motive power. These are the factors of primary importance upon which depends the earning capacity of locomotives.

Designs for your existing types of engines submitted upon request.

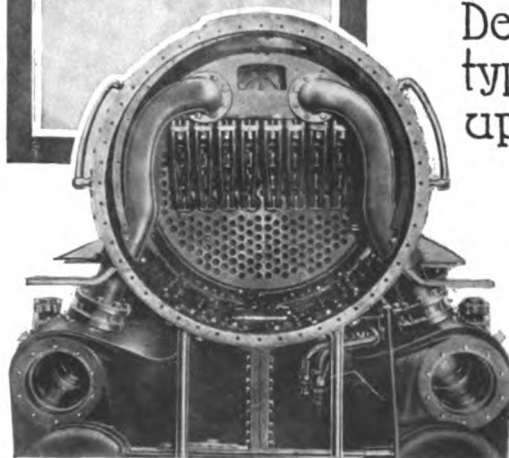

Locomotive Superheater Co.

New York
30 Church St.

Chicago
Peoples Gas Bldg.

William Sellers & Co. Incorp. Philadelphia, Pa.

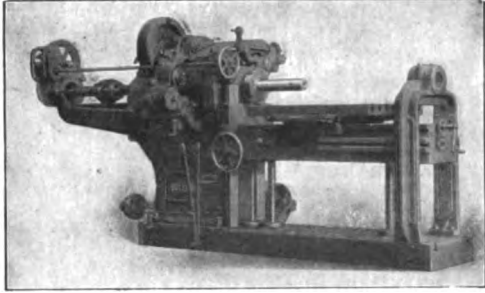

LABOR SAVING MACHINE TOOLS

The Drilling and Boring Machine shown has a steel spindle $4\frac{1}{4}$ " diameter, 55" stroke. The feeds are variable from finest drilling to coarse finishing. Power feed operated by positive clutch. Quick hand traverse. Table raised and lowered by power. Greatest height from top of table to centre of spindle 30". Yoke support for boring bar.

CRANES INJECTORS SHAFTING

SPRINGS

STEEL TIRED WHEELS

LOCOMOTIVE AND CAR WHEEL TIRES

RAILWAY STEEL-SPRING COMPANY

GENERAL OFFICES: 30 CHURCH ST., NEW YORK

BRANCHES: CHICAGO, DENVER, DETROIT, LOUISVILLE, MEXICO CITY, ST. LOUIS, ST. PAUL, WASHINGTON.

THE PENN COUPLER

Our latest development of the M. C. B. Coupler, a modification of our popular Pitt and Janney X Couplers, with latest improvements.

**Lock-To-The-Lock
Lock-Set and
Knuckle-Opener**

Send for blueprints and prices.

Manufactured only by

THE McCONWAY & TORLEY CO.

PITTSBURGH, PA.

Authoritative Tests

Know! Get facts and figures from disinterested laboratories.

We are prepared to determine for you, without fear or favor, the actual workable efficiency of any product—be it Machinery or Metal, Coal or Liquids, Paints or Oils; in short, any material for Railroad use.

We maintain thoroughly and scientifically equipped Testing Laboratories in the principal cities of the United States and at, practically, all the centers of Europe.

A Micro-Photography Laboratory in conjunction.

Send for Free Descriptive Booklet.

Robert W. Hunt & Company

OFFICES
 Chicago: 2206 Insurance Exchange Bldg. Montreal: 905 McGill Bldg.
 New York: 90 West Street. San Francisco: 251 Kearny St.
 Pittsburg: Monongahela Bank Bldg. Toronto: Traders' Bank Bldg.
 St. Louis: Syndicate Trust Bldg. Mexico City: Cinco de Mayo, 6 B.
 London, E. C.: Norfolk House, Cannon St. Seattle: 309 White Bldg.

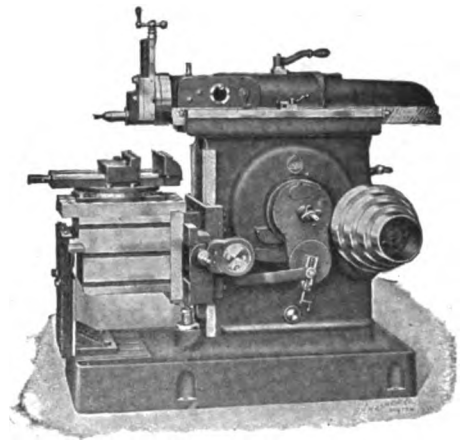

20" STOCKBRIDGE PATENTED TWO-PIECE-CRANK SHAPER

Where else can you find these shaper features? A cross feed that will feed knee in either direction, reversing without changing connecting rod or adjusting feed screw. Base is different, note depth; concaved on the outside and an oil pan cast on the inside. No chance for oil to get onto floor. The above are only two features in Stockbridge Shaper construction different from all others.

One of our new 20" Circulars gives you full description and illustrations of features. Shapers of all sizes, both cone and gear box drive.

STOCKBRIDGE MACHINE COMPANY

WORCESTER, MASS., U. S. A.

New York City Office: Niles-Bement-Pond Co., 111 Broadway.
 Chicago Office: Niles-Bement-Pond Co., 861 McCormick Bldg.

Thread your Pipe, Bolts and Nipples on one machine and save

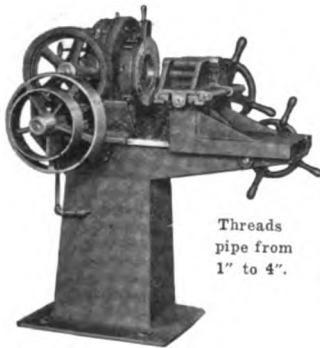

Threads pipe from 1" to 4".

OSTER PIPE-THREADING MACHINE No. 304A

THE machine that will only do one of these for you is an expense. The machine that does all of them is the one YOU want. No. 304-A does all three. Railroad reclamation shops are getting very valuable service from this wide-use machine. Its triple service saves the cost of extra machines, and its simple operation can be entrusted to a boy.

Read actual figures on the efficiency of Oster machines in "Actual Pipe-Threading Experiences." This booklet and the Oster catalog (at left) free to you by return mail.

The Oster Mfg. Co.
 2101 E. 61st Street
 CLEVELAND, O.



HOISTING
 FACTS
 FREE



Your copy is waiting
 Ask for it on the coupon

EVERY man who uses hoists in his plant or on outside work ought to read our new illustrated booklet, "Hoisting Your Profits." It's not a catalog—it's a user's booklet, showing how other concerns are profiting by using

CYCLONE HOISTS

in interesting ways. Perhaps it contains the very suggestion that will mean a big saving for you.

To get it by return mail, use the coupon

The Chisholm-Moore Mfg. Co.

5069 Lakeside Ave.,
 Cleveland, Ohio

Please send me "Hoisting Your Profits."
 Name.....
 Company.....
 Address.....
 City.....
 State..... (5069)

Problems

Loose Fitting Sash
 Easy Raising “
 Falling “
 Airtight Windows
 Dust Proof “
 Min. Repairs
 “Maintenance Cost

Solutions

Universal
 Weather
 Stripping
 and
 Sash
 Fixtures

Results

Satisfied
 Passengers
 and
 Railroad
 Officials

Consult the Cut Below and Satisfy Yourself That Our Devices Will Meet Your Requirements and Demands

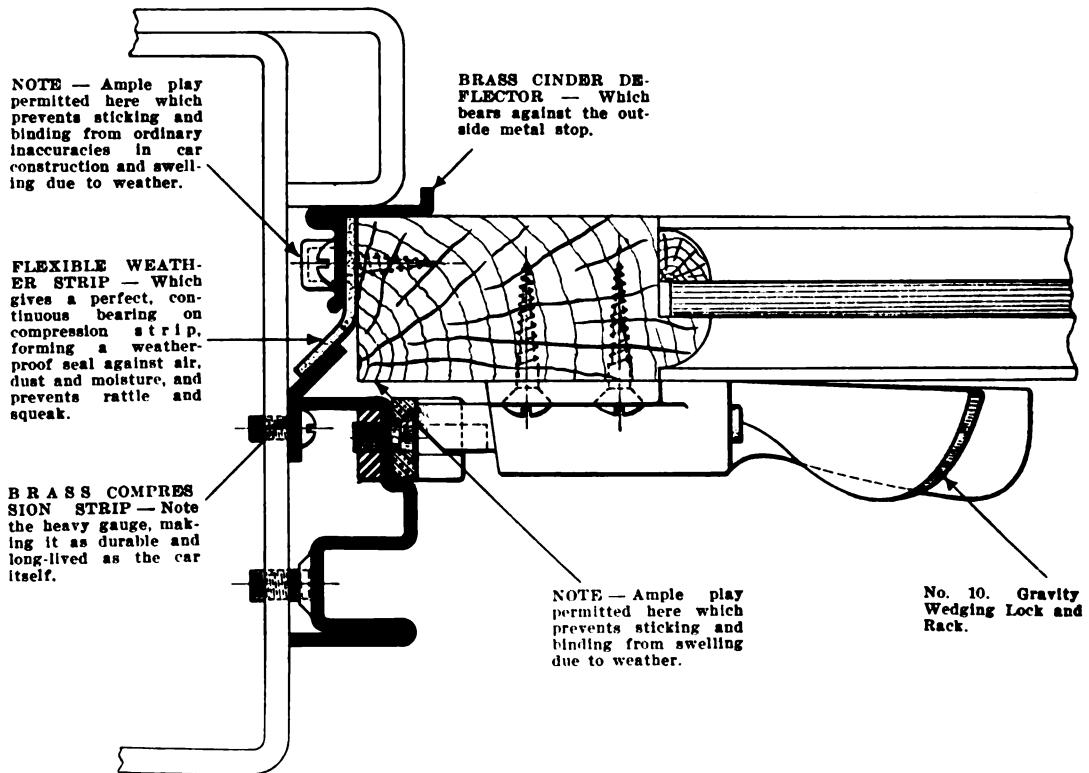

McCORD MFG. COMPANY

Universal Weather Stripping, Metal Sash, Sash Locks, Sash Balances, Drawn Metal Mouldings,
 Metal Stampings, Hose Protectors, McKim Gaskets

Detroit

Chicago

New York

ALPHABETICAL INDEX OF ADVERTISERS

A	G	
Acme Machinery Co..... —	Galena-Signal Oil Co..... 32	Newton Machine Tool Works, Inc..... 11
American Arch Co..... 30	General Electric Co..... 25	*Nicholson File Co..... —
American Balance Valve Co..... —	Globe Ventilator Co..... 36	Niles-Bement-Pond Co. 9
American Brake Shoe & Foundry Co..... —	Gould Coupler Co..... 34	Norton Co. 23
American Flexible Bolt Co..... —	Greenfield Tap & Die Corporation..... 22	O
American Locomotive Co..... 29		Oster Mfg. Co..... 3
American Tool Works Co..... 7	H	
Ashton Valve Co..... 22	Hilles & Jones Co..... 24	P
B	Hunt & Co., Robert W..... 3	Pratt & Letchworth Co..... —
Baldwin Locomotive Works, The..... 31	Hydraulic Press Mfg. Co..... 24	Pratt & Whitney Co..... 9
Bardons & Oliver 13		Prest-O-Lite Company, Inc., The..... 20
Baush Machine Tool Co..... 12	I	Prosser & Son, Thomas..... 36
*Beaudry & Company, Inc..... 20	International Oxygen Co..... 22	
Bridgeford Machine Tool Works..... 16		R
Bullard Machine Tool Co..... 26	J	Railway Materials Co..... 18
C	Jacobs-Shupert U. S. Firebox Co..... 28	Railway Steel-Spring Co..... 2
Canton Foundry & Machine Co..... 12	Jenkins Bros. 34	
Carborundum Co. 18	K	S
Chicago Car Heating Co..... 12	Krupp (Prosser & Son, Thomas)..... 36	Sellers & Co., Inc., William..... 2
Chisholm-Moore Mfg. Co..... 3		Shaw Propeller Co..... 24
Cincinnati Shaper Co..... 14	L	Stockbridge Machine Co..... 3
Coes Wrench Co..... 24	Landis Machine Co., Inc..... 18	Stucki Company, A..... 36
Commercial Acetylene Ry. Lt. & Signal Co. 34	Locomotive Superheater Co..... 1-27	
Commonwealth Steel Co..... —		U
D	M	Underwood & Co., H. B..... 22
Dearborn Chemical Co..... 12	McConway & Torley Co..... 2	Union Draft Gear Co..... 37
Detrick & Harvey Machine Co..... 20	McCord Mfg. Co..... 4	
Detroit Lubricator Co..... 28	Modern Tool Co..... 17	W
Dixon Crucible Co., Joseph..... 33	Morse Chain Co..... 21	Want Advertisements 34
F		Warner & Swasey Co..... 19
Firth-Sterling Steel Co..... —	N	Watertown Specialty Co..... 32
Flannery Bolt Co..... 35	Nathan Manufacturing Co..... 32	Westinghouse Air Brake Co..... 35
Foot-Burt Co., The..... 15	National Malleable Castings Co..... 36	Westinghouse Elec. & Mfg. Co..... 16
*Every other month.	National Tube Co..... —	Wiley & Russell Mfg. Co..... 22

CLASSIFIED DIRECTORY OF ADVERTISERS.

Accumulators, Hydraulic
Hydraulic Press Mfg. Co.

Acetylene.

Commercial Acetylene Railway
Light & Signal Co.

Acetylene Service.

Prest-O-Lite Company, Inc., The.

Air Brakes. (See Brakes, Air).

Arch, Locomotive Brick
American Arch Co.

Arresters, Lightning.

General Electric Co.

Automatic Relieving Lathes.

Niles-Bement-Pond Co.

Axles.

Krupp (Prosser & Son).
Prosser & Son, Thos.

Bars, Loco. Cylinder Boring.

Underwood & Co., H. B.

Bearing Metal. (See Metal, Bearing).

Bearings, Side.
Stuckl Company, A.

Bells, Locomotive.
National Tube Co.

Benders, Hydraulic, (Axle, Bar, Angle, Rod, Shaft, Etc.)
Hydraulic Press Mfg. Co.

Blow Torches.

Prest-O-Lite Company, Inc., The.

Blowers.

General Electric Co.

Boiler Compounds.

Dearborn Chemical Co.

Boiler Shop Machinery.

Landis Machine Co., Inc.
Niles-Bement-Pond Co.
Sellers & Co., Inc., Wm.

Boiler Washers and Testers.

Nathan Mfg. Co.
Sellers & Co., Inc., Wm.

Boilers, Locomotive.

American Locomotive Co.
Baldwin Locomotive Works, The

Bolsters, Truck and Body.

Commonwealth Steel Co.

Bolt Cutters.

Acme Machinery Co.
Foote-Burt Co.
Landis Machine Co., Inc.
Niles-Bement-Pond Co.

Bolt and Nut Machinery

Landis Machine Co., Inc.
Niles-Bement-Pond Co.

Boring Mills, Horizontal.

Detrick & Harvey Machine Co.
Niles-Bement-Pond Co.

Boring and Turning Mills.

Bullard Machine Tool Co.
Detrick & Harvey Machine Co.
Niles-Bement-Pond Co.
Sellers & Co., Inc., Wm.
Underwood & Co., H. B.

Brake Shoes.

Railway Materials Co.

Brake Wheels.

National Malleable Castings Co.

Brakes, Air.

General Electric Co.
Westinghouse Air Brake Co.

Buffers, Friction.

Gould Coupler Co.

Bulldozers.

Canton Foundry & Machine Co.

Bulldozers, Hydraulic.

Hydraulic Press Mfg. Co.

Cables.

General Electric Co.

Car Axles. (See Axles).

Carborundum.

Carborundum Co.

Car Door Fasteners.

National Malleable Castings Co.

Car Door Fixtures.

Railway Utility Co.

Car Flooring. (See Floors, Car).

Car Heaters. (See Heaters, Car).

Car Lighting. (See Lighting, Car).

Car Roofs. (See Roofs, Car).

Cars, Motor.

General Electric Co.

Car-Wheel Boring Machines.

Niles-Bement-Pond Co.

Car Window Fixtures.

McCord Manufacturing Co.

Castings, Iron and Steel.

Commonwealth Steel Co.
Gould Coupler Co.
Krupp (Prosser & Son).
McConway & Torley Co.
National Malleable Castings Co.
Prosser & Son, Thos.

Castings, Malleable Iron.

National Malleable Castings Co.

Center Plates.

National Malleable Castings Co.

Centering Machines.

Niles-Bement-Pond Co.

Chains, Driving.

Morse Chain Co.

Clay, Fire

Carborundum Co.

Cocks.

National Tube Co.
Watertown Specialty Co.

Cocks, Cylinder.

Watertown Specialty Co.

Compressors, Air.

General Electric Co.

Controllers.

General Electric Co.

Counterbores.

Pratt & Whitney Co.

Couplers, Car.

Gould Coupler Co.
McConway & Torley Co.
National Malleable Castings Co.

Couplings, Union.

National Tube Co.

Cranes.

Niles-Bement-Pond Co.

Cranes, Portable

Canton Foundry & Machine Co.

Crank Pins.

Krupp (Prosser & Son).
Prosser & Son, Thos.

Crank Pin Turning Machines.

Niles-Bement-Pond Co.
Underwood & Co., H. B.

Crushers and Pulverizers.

Krupp (Prosser & Son).
Prosser & Son, Thos.

Cutter Grinders.

Niles-Bement-Pond Co.

Cutting(Oxy-Acetylene Process).

Prest-O-Lite Company, Inc., The.

Cylinders, Hydrogen and Oxygen.

International Oxygen Co.

Dies.

Landis Machine Co., Inc.
Pratt & Whitney Co.

Draft Gears.

Commonwealth Steel Co.

Draft Rigging and Attachments

Union Draft Gear Co.

Draw-Bridge Machinery.

Nichols & Bro., Geo. P.

Drilling Machines.

American Tool Works Co.
Detrick & Harvey Machine Co.
Foote-Burt Co.
Niles-Bement-Pond Co.
Pratt & Whitney Co.
Sellers & Co., Inc., Wm.

Drilling Machines (Arch Bar.)

Foote-Burt Co.
Niles-Bement-Pond Co.

Drilling Machines, Horizontal.

Foote-Burt Co.

Drilling Machines, Multiple.

Bausch Machine Tool Co.
Foote-Burt Co.
Niles-Bement-Pond Co.
Pratt & Whitney Co.

Drilling Machines, Radial.

American Tool Works Co.
Bausch Machine Tool Co.
Niles-Bement-Pond Co.

Drills.

Foote-Burt Co.
Pratt & Whitney Co.

Driving Wheel Centers.

Commonwealth Steel Co.
Krupp (Prosser & Son).
Prosser & Son, Thos.

Dynamos and Motors.

General Electric Co.

Electric Lighting and Power.

General Electric Co.
Westinghouse Electric & Mfg. Co.

Engineers.

Hunt & Co., Robert W.

Engine Frames. (See Frames, Engine).

Exhaust Fans and Heads.

General Electric Co.

Expanders, Flue.

Krupp (Prosser & Son).
Pratt & Whitney Co.
Prosser & Son, Thos.

Fans, Electric.

General Electric Co.
Westinghouse Electric & Mfg. Co.

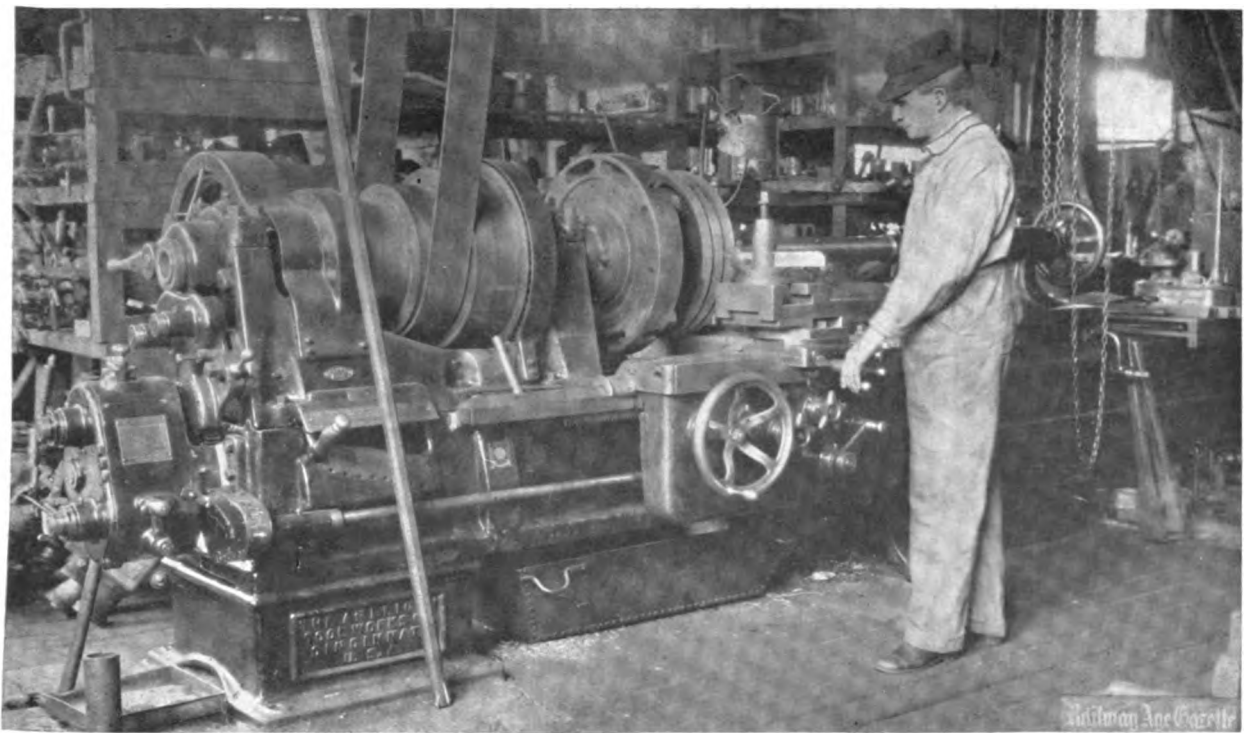

Job:—Finishing complete a cast-iron piston.
 Size:—See drawing below.
 Time:—Including two settings, 1½ hour.
 Operations:—Face both ends, removing an average of ½ inch of metal. Bore for rod fit. Turn down and finish outside of piston, and cut grooves for packing rings.

For Everyday Heavy Lathe Work in Railroad Shops there is nothing that is quite as satisfactory to all concerned as an

“American” High Duty Lathe

Massive in design, with an abundance of power, these machines fill the most exacting requirements of railroad shop service.

For nearly five years the 30-inch lathe shown above has been working on piston heads, piston rods, piston spiders, bull rings, etc. During this time there have been practically no repairs or delays, and no weaknesses have shown up even under the heaviest cuts. Wherever you find an “American,” you’ll find it doing good work, day in and day out.

Perhaps there is, or soon will be, need of an “American” High Duty Lathe in your shops. Now is the time to get busy.

The American Tool Works Co.

Makers of reliable Lathes, Planers, Shapers and Radials

CINCINNATI, U. S. A.

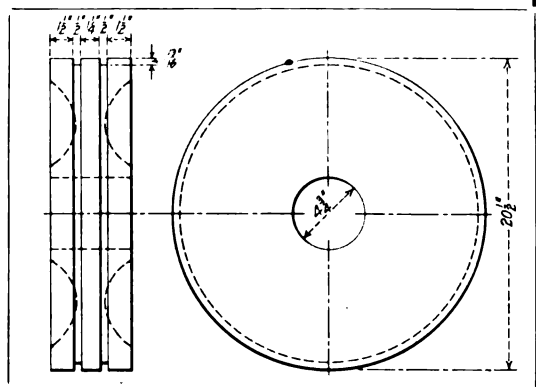

CLASSIFIED DIRECTORY OF ADVERTISERS—(Continued.)

File Cleaners. Nicholson File Co.	Hammers, Steam. Beaudry & Co., Inc.	Lathes, Turret. Bardons & Oliver. Niles-Bement-Pond Co. Pratt & Whitney Co. Sellers & Co., Inc., Wm. Warner & Swasey Co.	Mouldings, Drawn Metal. McCord Manufacturing Co.
Files. Nicholson File Co.	Hammers, Trip. Beaudry & Co., Inc.	Lighting, Car. Commercial Acetylene Light & Signal Co. General Electric Co. Gould Coupler Co.	Multiple Drills. Niles-Bement-Pond Co. Pratt & Whitney Co.
Files, Toolmaking. Nicholson File Co.	Handles, File. Nicholson File Co.	Lighting, Railway. Commercial Acetylene Light & Signal Co. General Electric Co. Gould Coupler Co.	Nipple Threading Machines. Laudis Machine Co., Inc.
Fire Boxes. Jacobs-Shupert U. S. Firebox Co.	Headlights. Commercial Acetylene Light & Signal Co. General Electric Co.	Locomotive Arch Tubes. National Tube Co.	Nipples (Wrought). National Tube Co.
Fittings. National Tube Co.	Heaters, Car. Chicago Car Heating Co.	Locomotives. American Locomotive Co. Baldwin Locomotive Works, The	Oils. Galena-Signal Oil Co.
Flanges (Cast and Malleable Iron). National Tube Co.	Holsts, Electric. Niles-Bement-Pond Co.	Locomotive Boilers. (See Boilers, Locomotive).	Oil Cups. Detroit Lubricator Co. Nathan Mfg. Co.
Flanging Machines. Hilles & Jones Co.	Holsts, Portable. Canton Foundry & Machine Co. Chisholm-Moore Mfg. Co.	Locomotive Brick Arch. (See Arch, Locomotive Brick).	Oil Stones Carborundum Company.
Flanging Presses. Niles-Bement-Pond Co.	Hose, Air Brake. Westinghouse Air Brake Co.	Locomotives, Compressed Air. Baldwin Locomotive Works, The	Oxy-Acetylene Apparatus. International Oxygen Co.
Flue Cutters. Underwood & Co., H. B.	Hose Protectors. McCord Manufacturing Co.	Locomotives, Electric. American Locomotive Co. Baldwin Locomotive Works, The General Electric Co. Westinghouse Electric & Mfg. Co.	Oxy-Hydrogen. International Oxygen Co.
Fine Expanders. (See Expanders, Flue).	Hydraulic Presses and Pumps. (See Presses, Hydraulic; Pumps, Hydraulic.)	Locomotives, Mine. Baldwin Locomotive Works, The General Electric Co.	Oxygen. International Oxygen Co.
Forgings. Krupp (Prosser & Son). Prosser & Son, Thos.	Hydrogen. International Oxygen Co.	Lubricants. Dixon Crucible Co., Jos.	Packing. Jenkins Bros.
Furnaces. Railway Materials Co.	Injectors. Nathan Mfg. Co. Sellers & Co., Inc., Wm.	Lubricators. Detroit Lubricator Co. Nathan Mfg. Co.	Pedestal Facers. Underwood & Co., H. B.
Gap Lathes. Bridgeford Machine Tool Works. Niles-Bement-Pond Co.	Insulating Materials. General Electric Co.	Lubricators, Force Feed. McCord Mfg. Co.	Pipe. National Tube Co.
Gages. Pratt & Whitney Co.	Journal Boxes and Lids. Gould Coupler Co. National Malleable Castings Co.	Machine Tools. Acme Machinery Co. American Tool Works Co. Bardons & Oliver. Baush Machine Tool Co. Bridgeford Machine Tool Works. Bullard Machine Tool Co. Cincinnati Shaper Co. Foot-Burt Co. Hilles & Jones Co. Laudis Machine Co., Inc. Niles-Bement-Pond Co. Pratt & Whitney Co. Sellers & Co., Inc., Wm. Stockbridge Machine Co. Underwood & Co., H. B. Warner & Swasey Co.	Pipe Benders. Underwood & Co., H. B.
Gages, Water. Nathan Mfg. Co.	Lamps, Flare. Prest-O-Lite Company, Inc., The.	Machine Tools, Hydraulic. Hydraulic Press Mfg. Co. Niles-Bement-Pond Co.	Pipe Coils. National Tube Co.
Gaskets. McCord Manufacturing Co.	Lamps, Gas. Commercial Acetylene Light & Signal Co.	Metal Stampings. McCord Manufacturing Co.	Pipe Threading Machinery. Oster Mfg. Co.
Geared Head Lathes. Niles-Bement-Pond Co.	Lamps, Incandescent. General Electric Co. Westinghouse Electric & Mfg. Co.	Milling Cutters. Pratt & Whitney Co.	Pipe Threading and Cutting-Off Machinery. Laudis Machine Co., Inc. Niles-Bement-Pond Co.
Generating Sets. General Electric Co.	Lathes. American Tool Works Co. Bardons & Oliver. Bridgeford Machine Tool Works. Bullard Machine Tool Co. Niles-Bement-Pond Co. Pratt & Whitney Co. Sellers & Co., Inc., Wm. Warner & Swasey Co.	Milling Machines. Detrick & Harvey Machine Co. Niles-Bement-Pond Co. Pratt & Whitney Co. Underwood & Co., H. B.	Piston Rods. Krupp (Prosser & Son). Prosser & Son, Thos.
Generators, Hydrogen and Oxygen. International Oxygen Co.	Lathes, Axle. Bridgeford Machine Tool Works.	Mining Machinery. Krupp (Prosser & Son). Prosser & Son, Thos.	Planers. Detrick & Harvey Machine Co. Niles-Bement-Pond Co. Sellers & Co., Inc., Wm.
Grinding Machines. Modern Tool Co. Niles-Bement-Pond Co. Pratt & Whitney Co.	Lathes, Brass Workers. Niles-Bement-Pond Co.	Motors, Electric. General Electric Co. Westinghouse Electric & Mfg. Co.	Planers, Valve Seat. Underwood & Co. H. B.
Grinding Wheels Carborundum Company. Norton Company.	Lathes, Driving Wheel. Niles-Bement-Pond Co.		Planing Attachment, Radial. Underwood & Co., H. B.
Hammers, Board and Steam Drop. Niles-Bement-Pond Co.	Lathes Engine (Heavy). Bridgeford Machine Tool Works.		Planing Machines. American Tool Works Co. Niles-Bement-Pond Co. Underwood & Co., H. B.
Hammers, Pneumatic. Sellers & Co., Inc., Wm.	Lathes, Journal Truing. Bridgeford Machine Tool Works.		Platforms, Steel. Commonwealth Steel Co.
Hammers, Power. Beaudry & Co., Inc.			Pointing Machines, Bolt. Laudis Machine Co., Inc.
			Portable Tools. (See Tools, Portable).
			Presses, Hydraulic (Arbor, Axle, Bending, Broaching, Car Wheel, Flanging, Forging, Forming, Straightening, Wheel). Hydraulic Press Mfg. Co. Niles-Bement-Pond Co.

Both Wheels Pressed Off The Axle Simultaneously

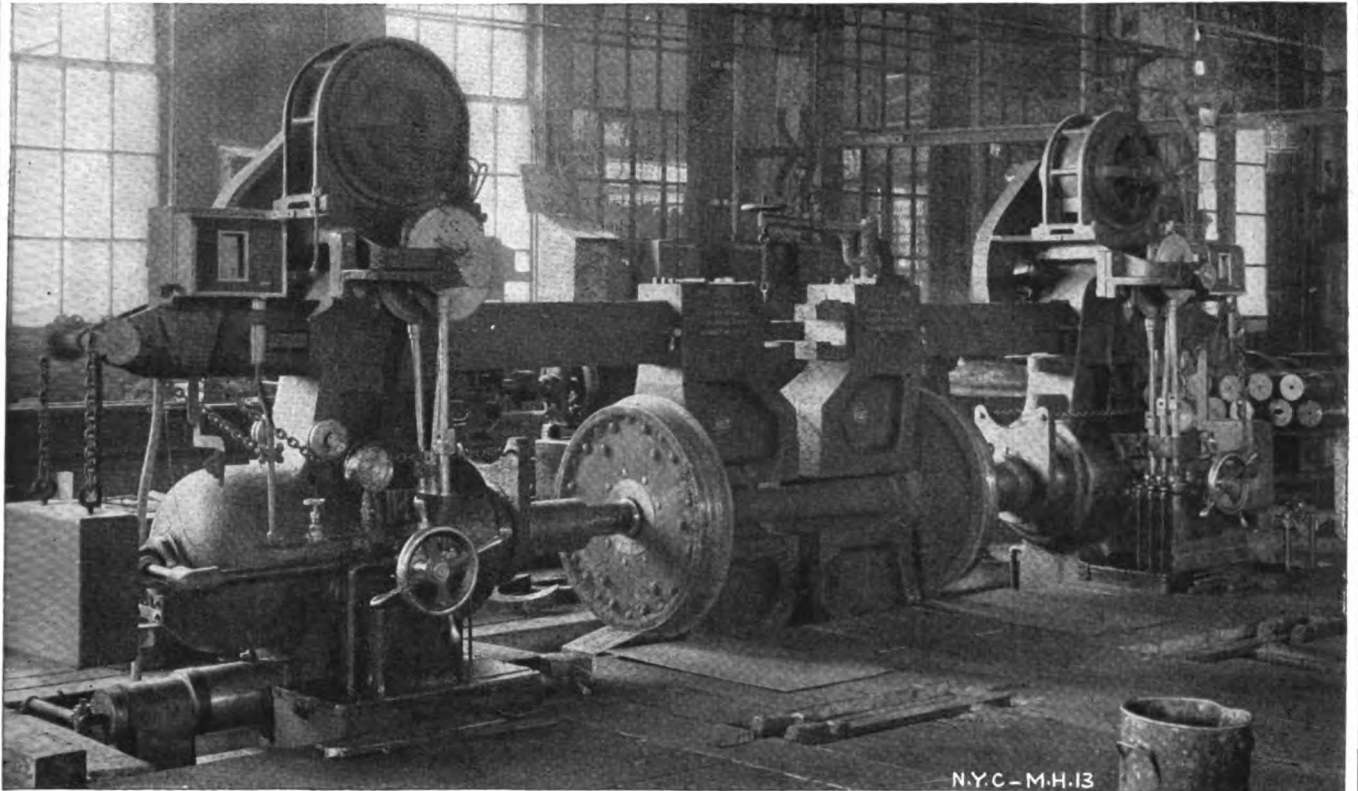

N.Y.C.-M.H.13

Showing machine in operation at the Mott Haven shops of the New York Central Railroad: Pressing off Wheels.

Niles Patented Double Hydraulic Car-Wheel Press

FOR SHOPS HANDLING LARGE NUMBERS OF WHEELS. HAS PRESSED OFF 30 PAIRS PER HOUR.

Pressing Off

Coupling blocks are removed from upper and lower tie bars, a small crane, as shown in illustration, being provided for handling upper coupling block. Wheels are rolled into machine and a forcing block placed over each ram. Pressure is then applied to main cylinders. As soon as rams are in contact with ends of axle, the pressure starts each cylinder backward on base plate, pulling tie bars and resistance posts away from center of machine, thus drawing both the wheels off their axles simultaneously. To bring the cylinders, tie bars and resistance posts back to their initial

positions, an auxiliary cylinder is located under each main cylinder.

Pressing On

When pressing on a pair of wheels, the coupling blocks are put in place, securely locking the tie bars together. The axle is held on an assembling jack or by a crane while the wheels are run over the journals. A shoe is placed on the face of each ram for forcing on the wheels. The axles and wheels are then rolled into the machine, the pumps started and the wheels forced upon their fits simultaneously.

Write for Progress Reporter No. 25.

NILES-BEMENT-POND CO., 111 Broadway, New York City 25 Victoria St., London, S. W.

SALES OFFICES AND AGENCIES: Boston: 93-95 Oliver St. Philadelphia: 21st and Callowhill Sts. Pittsburgh: Frick Bldg. Cleveland: The Niles Tool Works Co., Rockefeller Bldg. Hamilton, O.: The Niles Tool Works Co. Chicago: McCormick Bldg. St. Louis: 516 North Third St. Agent for Gulf States: N. C. Walpole, 2015 First Ave., Birmingham, Ala. Colorado: Hendrie & Bolthoff Mfg. & Supply Co., Denver. For California, Nevada and Arizona: Harron, Rickard & McCone, San Francisco and Los Angeles. For Washington and Idaho: Hallide Mchy. Co., Seattle and Spokane. For Oregon: Portland Machinery Co., Portland. Canada: The John Bertram & Sons Co., Ltd., Dundas, Montreal, Vancouver, Winnipeg. Japan: The F. W. Horne Co., 6 Takiyama-cho, Kyobashi-ku, Tokio. Italy: Ing. Ercole Vaghi, Milan. Germany: F. G. Kretschmer & Co., Frankfurt a/M. France: Glaeuzer & Perreaud, 18 Faubourg du Temple, Paris. Austria: E. Krause & Co., Vienna, Prague and Budapest. Holland: R. S. Stokvis & Zonen, Ltd., Rotterdam. For Mexico: The Railway Supply Co., S. A. Cinco de Mayo, 6, Mexico City. Russia: S. G. Martin & Co., Ltd., Petrograd and Moscow. Brazil: Comptoir Technique Bresilien, P. O. Box 802, Rio de Janeiro.

CLASSIFIED DIRECTORY OF ADVERTISERS—(Continued.)

<p>Pumps, Hydraulic (Steam, Belt or Motor Driven). Hydraulic Press Mfg. Co.</p>	<p>Sheet Steel. Simplex Railway Appliance Co.</p>	<p>Tools, Threading. Modern Tool Co.</p>	<p>Ventilators, Car. Globe Ventilator Co.</p>
<p>Punches. Niles-Bement-Pond Co. Sellers & Co., Inc., Wm.</p>	<p>Signal Lighting. Commercial Acetylene Railway Light & Signal Co.</p>	<p>Tools for Railway Repair Shops. Underwood & Co., H. B.</p>	<p>Ventilators. Globe Ventilator Co.</p>
<p>Punching and Shearing Machines. Hilles & Jones Co. Niles-Bement-Pond Co. Pratt & Letchworth Co.</p>	<p>Signal Pipe. National Tube Co.</p>	<p>Tool Steel. Firth-Sterling Steel Co. Krupp (Prosser & Son). Prosser & Son, Thos.</p>	<p>Ventilating Fans. General Electric Co.</p>
<p>Rasps. Nicholson File Co.</p>	<p>Slotting Machines. Niles-Bement-Pond Co.</p>	<p>Transfer Tables. Nichols & Bro., Geo. P.</p>	<p>Washers, Lock. National Malleable Castings Co.</p>
<p>Reamers. Pratt & Whitney Co.</p>	<p>Sockets—Drill and Reamer. Pratt & Whitney Co.</p>	<p>Traps, Steam. National Tube Co.</p>	<p>Water Purifiers. Dearborn Chemical Company.</p>
<p>Reamers, Adjustable. Pratt & Whitney Co.</p>	<p>Springs. Railway Steel-Spring Co.</p>	<p>Trucks. Commonwealth Steel Co. McConway & Torley Co.</p>	<p>Weather Strips. McCord Manufacturing Company.</p>
<p>Regrinding Valves. National Tube Co.</p>	<p>Staybolts. American Flexible Bolt Co. Flannery Bolt Co.</p>	<p>Trucks, Electric. American Locomotive Co. Baldwin Locomotive Works, The</p>	<p>Welding (Oxy-Acetylene Process) Commercial Acetylene Railway Light & Signal Co. Prest-O-Lite Company, Inc., The</p>
<p>Safe Ends. National Tube Co.</p>	<p>Staybolt and Bolt Turning Machines. Brush Machine Tool Co. Laudis Machine Co., Inc.</p>	<p>Tubes, Boiler. Krupp (Prosser & Son). National Tube Co. Prosser & Son, Thos.</p>	<p>Welding and Cutting Apparatus. International Oxygen Co.</p>
<p>Sash Balances. McCord Manufacturing Co.</p>	<p>Staybolt Taps. Pratt & Whitney Co. Wiley & Russell Mfg. Co.</p>	<p>Tubes, Seamless Steel. National Tube Co.</p>	<p>Welding Apparatus (Electric Arc). Westinghouse Electric & Mfg. Co.</p>
<p>Sash Locks. McCord Manufacturing Co.</p>	<p>Stocks and Dies. Pratt & Whitney Co. Wiley & Russell Mfg. Co.</p>	<p>Turntables, Industrial Shop. Canton Foundry & Machine Co.</p>	<p>Welding Apparatus (Oxy-Acetylene Process). Prest-O-Lite Company, Inc., The.</p>
<p>Sash, Metal. McCord Manufacturing Co.</p>	<p>Superheaters. Locomotive Superheater Co.</p>	<p>Turntable Tractors. Nichols & Bro., Geo. P.</p>	<p>Welding Supplies. Prest-O-Lite Company, Inc., The.</p>
<p>Screw Machines. Warner & Swasey Co.</p>	<p>Tanks. Krupp (Prosser & Son). National Tube Co. Prosser & Son, Thos.</p>	<p>Unions. National Tube Co.</p>	<p>Welding Tools. International Oxygen Co.</p>
<p>Sensitive Drill Presses. Niles-Bement-Pond Co.</p>	<p>Taps. Pratt & Whitney Co. Wiley & Russell Mfg. Co.</p>	<p>Valves. Jenkins Bros. National Tube Co.</p>	<p>Wheels, Car and Locomotive. Krupp (Prosser & Son). Prosser & Son, Thos. Railway Steel-Spring Co.</p>
<p>Shapers. American Tool Works Co. Cincinnati Shaper Co. Niles-Bement-Pond Co. Pratt & Whitney Co. Sellers & Co., Inc., Wm. Stockbridge Machine Co.</p>	<p>Testing Apparatus, Oxygen. International Oxygen Co.</p>	<p>Valves, Cylinder Stud, Oxygen and Hydrogen. International Oxygen Co.</p>	<p>Wheels, Steel Tired. Railway Steel-Spring Co.</p>
<p>Shafting. Krupp (Prosser & Son). Prosser & Son, Thos.</p>	<p>Tie Plates. National Malleable Castings Co.</p>	<p>Valves, Hydraulic. Hydraulic Press Mfg. Co. National Tube Co.</p>	<p>Whistles. Ashton Valve Co. General Electric Co. Nathan Mfg. Co.</p>
<p>Shapes, Vertical. Pratt & Whitney Co.</p>	<p>Tires (Steel). Krupp (Prosser & Son). Prosser & Son, Thos. Railway Steel-Spring Co.</p>	<p>Valves, Muffler Safety. Nathan Mfg. Co.</p>	<p>Window Fixtures. McCord Manufacturing Co.</p>
<p>Shears. Niles-Bement-Pond Co.</p>	<p>Tire Turning and Boring Mills. Niles-Bement-Pond Co.</p>	<p>Valves, Open Safety. Nathan Mfg. Co.</p>	<p>Wrecking Hooks. National Malleable Castings Co.</p>
<p>Shears, Alligator. Canton Foundry & Machine Co.</p>	<p>Tools, Portable. Underwood & Co., H. B.</p>	<p>Valves—Pop, Safety, Throttle and Blow-Off. Ashton Valve Co. Detroit Lubricator Co. Nathan Mfg. Co.</p>	<p>Wrenches. Coes Wrench Co. Shaw Propeller Co.</p>

Sawing Reclaimed Car Axles

Reclaiming car axles and using them for tender truck axles, is one of the economies practiced in an eastern railway shop.

The illustration shows a reformed axle being cut to length on a 36"

NEWTON COLD METAL SAW

With a feed of $\frac{3}{4}$ " per minute and a cutting feed of 35 feet per minute, the 6" axle is cut off in 8 minutes.

In the eight years this machine has been in operation, it has not cost a dollar for repairs—which is conclusive evidence of its staunchness, strength and durability.

Where faster cutting rates are desired, we recommend our Cold Metal Sawing Machines that have the gear feed boxes incorporated.

A short cut towards economy and production is to write for the Newton Catalog No. 47A.

Newton Machine Tool Works, Inc.
Philadelphia, U.S.A.

Boring Machines

Milling Machines

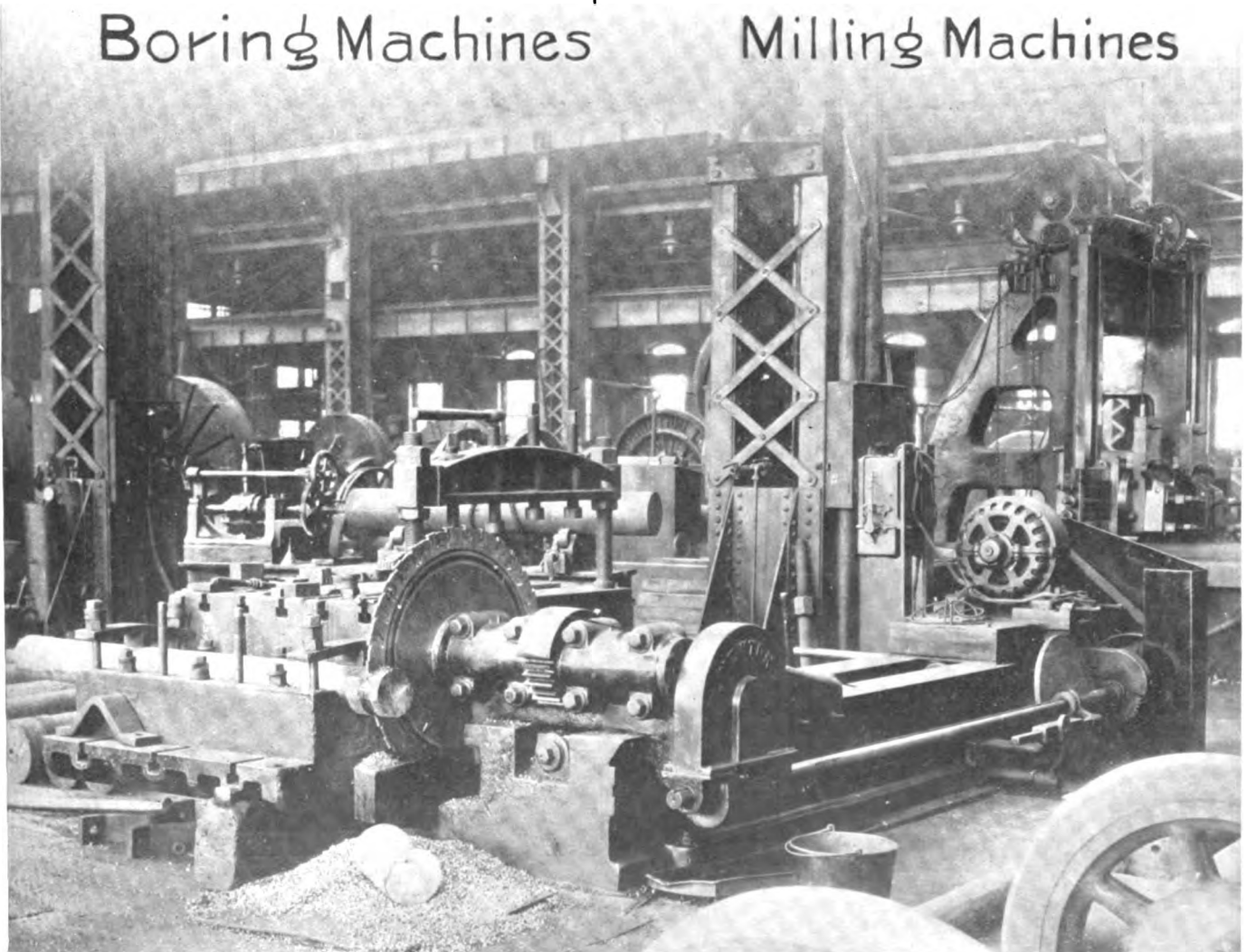

Dearborn Service

is an important safety factor in railroad operation. Aside from the savings and increased locomotive earning capacity that result when Dearborn Treatment is used to prevent scale formation, corrosion, pitting, and foaming, clean boilers remove an element of danger from boiler explosions.

Dearborn Treatment is always based on analyses of the waters to be treated, the injurious elements in the water being determined with scientific correctness, and taken care of with suitable reagents.

Send gallon samples for analysis.

Dearborn Chemical Company

McCormick Building,
CHICAGO.

Lassiter Stay Bolt Threading and Reducing Machine

Built with
Four, Six and Eight Spindles



25 to 35 PER SPINDLE—PER HOUR

Automatic reduction of center made while threading without additional expense.

Send for pamphlet.

Bausch Machine Tool Company Springfield, Mass.

NEW YORK OFFICE: 50 Church Street
CHICAGO OFFICE: McCormick Building

Drilling Machinery

Consisting of Radial Drills, Multiple Drills, Special Multiple Drilling Machines.

Also Lassiter Straight and Taper Bolt Turning Machines. Staybolt Drilling Machines.

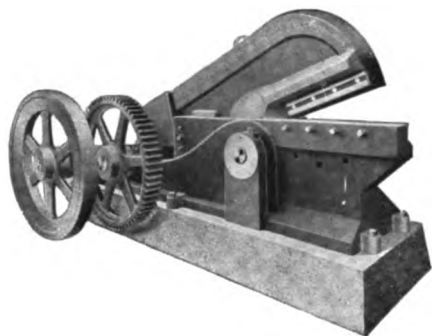

Requires 60% Less Power

Power consumed is the important consideration of an Alligator Shear. Unnecessary consumption of power means loss figured in dollars and cents. The

CANTON ALLIGATOR SHEARS

require 60% less power to drive them than others of equal capacity. The reason is the Double Gears and Pinions. They produce a perfect balance that means accuracy and smoothness in operation. They eliminate the possibilities of torsional strain that result in broken or twisted crank and counter Shafts.

Write for the Canton Shear Catalog "D-17." It gives you full particulars of all styles, sizes and types.

THE CANTON FOUNDRY & MACHINE CO.
Canton Ohio

Also makers of Industrial Turn Tables—
Portable Floor Cranes and Hoists.

VAPOR SYSTEM

OF

CAR HEATING

Direct Steam Heat without any pressure on the radiating pipes. Pressure retained in train pipe. Considerably less drain on the locomotive.

CHICAGO CAR HEATING CO.

CHICAGO: RAILWAY EXCHANGE BLDG.
NEW YORK: GRAND CENTRAL TERMINAL BLDG.
WASHINGTON, D. C.: 829 MUNSEY BLDG.
MONTREAL, QUE.: 61 DALHOUSIE STREET.
ATLANTA, GA.: CANDLER BLDG.

Plenty of power and rigidity for railroad work, and at the same time is particularly adapted to handle short runs efficiently.

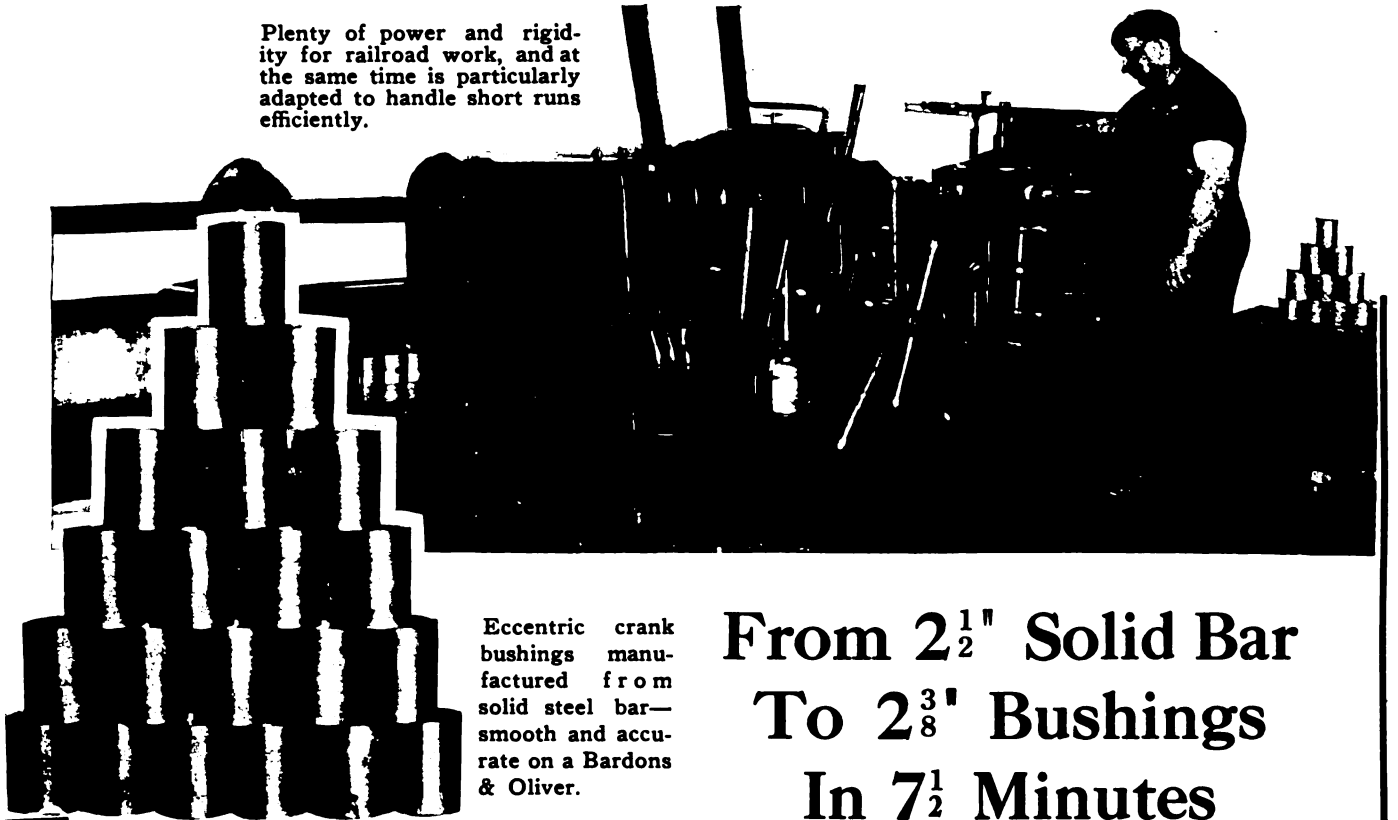

Eccentric crank bushings manufactured from solid steel bar—smooth and accurate on a Bardons & Oliver.

From 2¹/₂" Solid Bar To 2³/₈" Bushings In 7¹/₂ Minutes

The operator, a man with years of turret lathe experience and acquainted with the dozen different machines in one of the largest railroad shops in the country, where this one is, says: "I'd Rather Work On It Than Any Other Lathe In the Shops." Such expressions are the rule if you interview operators of

Bardons & Oliver Turret Lathes

They have good reasons, too, for their opinions. Their machines are powerful and rapid producers, extremely strong and rigid, and do not have to be "favored," but "handle" any piece within their capacity without vibration or interruption. The 3¹/₂" machine shown is manufacturing Eccentric Crank Bushings from 2¹/₂" solid steel bar in 7¹/₂ minutes. Here are the steps in their production if .25 to .30 Carbon, which we assume is used:

Chucking, and drilling with 1 ³ / ₈ drill	4	minutes
Enlarging hole to 2"	2 ¹ / ₂	"
Chamfer inside corner	1/2	"
Cutting off	1/2	"
	<hr style="width: 100px; margin: 0 auto;"/>	
	7 ¹ / ₂	minutes

Outside formed while hole is being enlarged.

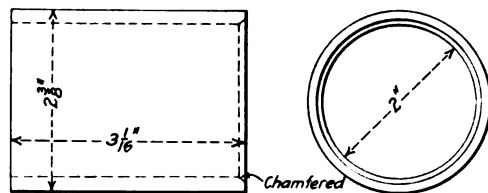

When this job is completed, it takes very little time to change the tools in the turret for the next job—that's one of the features of Bardons & Oliver machines, quick tool changes—and it's a very valuable feature for railroad work.

Let us give you more information on how Bardons & Oliver Turret Lathes can save money in your shops—if, you'll give them the chance.

Before you forget—write now.

BARDONS & OLIVER

Builders of High Grade Turret Machinery

CLEVELAND, O., U. S. A.

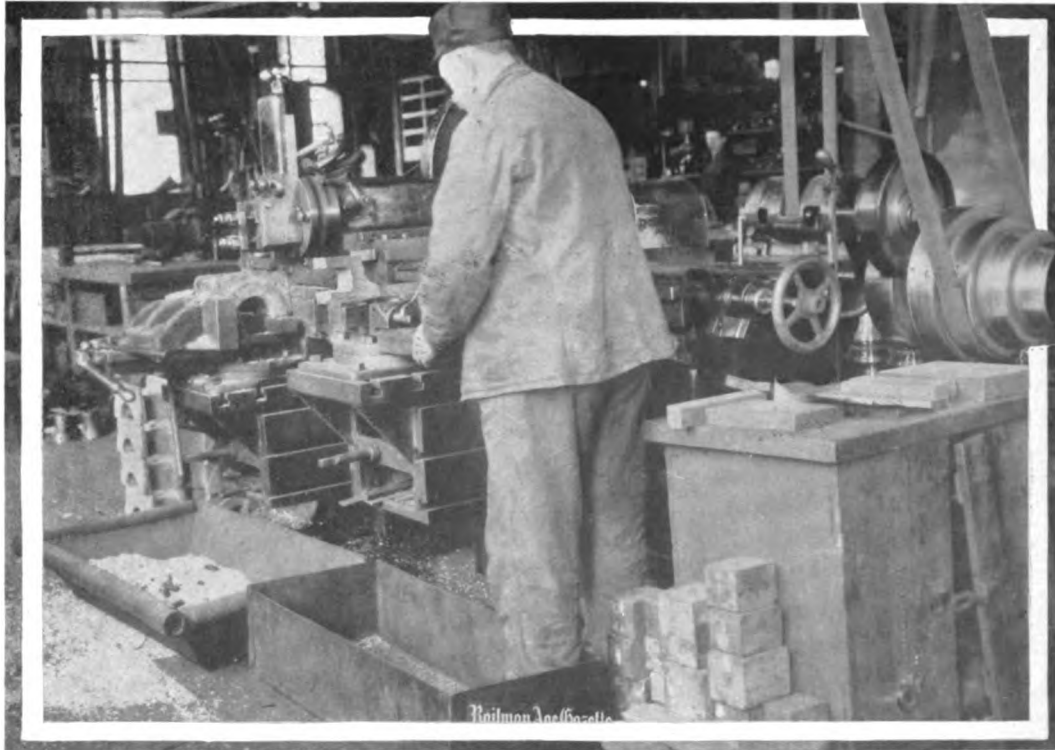

Regular 26-Inch Single Head Cincinnati Traverse Shaper in Railroad Service. The Operator is setting up a job, link clevice, on one table, while the head is at work on a main rod brass, on the other table.

Why So Many Railroad Shops Are Using Cincinnati Traverse Shapers

A visit to any of the more efficiently managed shops will usually disclose one or more Cincinnati Traverse Shapers. Why? Because this machine tool is *particularly efficient on railroad work*.

Having two tables, work can be done on one while the operator is setting work up on the other. See illustration. This means more work from one operator. It is an excellent *rush job* machine—as there is always the extra table, and work already set up on the other table need not be disturbed.

The two-table feature provides a means of doing large work impossible on a pillar shaper—such as side rods, eccentric rods, frame cross ties, car truck equalizers, combination levers, etc. The “Cincinnati Traverse” does these at a remarkable saving of time over other machines.

The Cincinnati Traverse Shaper is an interesting and highly efficient machine for *your* shops. If you are not well acquainted with it send for catalogue H.

The Cincinnati Shaper Co.
Cincinnati, Ohio

Makes Quick Work Of Flue Sheets, Mud Rings Etc.

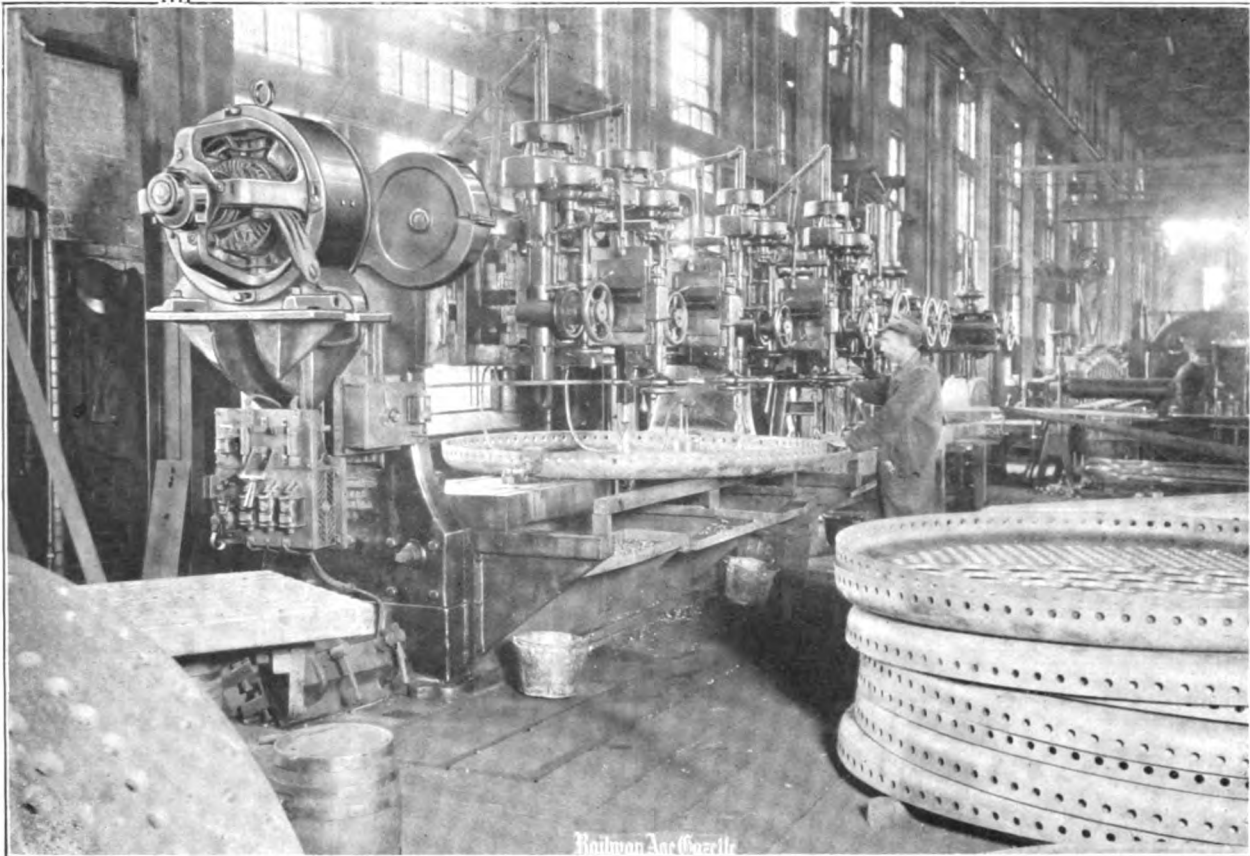

For drilling Flue Sheets, Side and Barrel Sheets, Mud Rings, etc., there is no machine that can equal the

Foote-Burt No. 2 Mud Ring and Flue Sheet Drill

Arranged with four No. 27A Heads.

On account of the size of the flue sheet shown, only two of the four spindles on the machine are used.

The flue sheet shown is $\frac{1}{2}$ " thick—Operations: 302 holes, 2 1-16" in diameter, time per hole 19 seconds; 23 holes, $1\frac{1}{4}$ " in diameter, time per hole, 18 seconds; 36 holes, 4 15-32" in diameter, time per hole, 75 seconds.

On mud rings (wrought iron), four 13-16" holes are drilled through 5" in $1\frac{1}{2}$ minutes—using four spindles at once.

This machine gives the operator all he can ask in speed, rigidity, and convenience in handling. The adjustable speed, individual motor drive gives any desired speed—whatever one gives best results for the work being done.

Each spindle is arranged with Independent Power Feed and adjustable stop for automatically knocking off same, and convenient clutch for stopping and starting.

Spindle heads are mounted on knee type brackets and have an in and out movement from the main crossrail of 18 inches and are also adjustable to different center distances.

These machines are found in shops where efficiency is demanded. Ask us for list of installations, and bulletin giving all the facts.

The Foote-Burt Company

Cleveland, Ohio

THE "MODERN"

PLAIN SELF-CONTAINED GRINDING MACHINE

A HIGH DUTY TOOL FOR ACCURATE AND RAPID PRODUCTION

A newly designed Self-Contained Grinding Machine that has various exclusive features, in connection with superior general design, that give it ability to do accurate and efficient work.

These Machines are built in two types with 12" or 16" swing, and in four lengths, 2', 3', 4' and 5', and are of the heavy, rigid construction so necessary to the rapid production of finished parts. The capacity of the larger machines adapts them particularly to railroad work.

A notable feature is our patented speed-change gear box which is a compact unit through which are obtained **twelve work speeds and six table feeds**.

A full description of these Machines appears in this issue.

MODERN TOOL COMPANY

ERIE, PA.

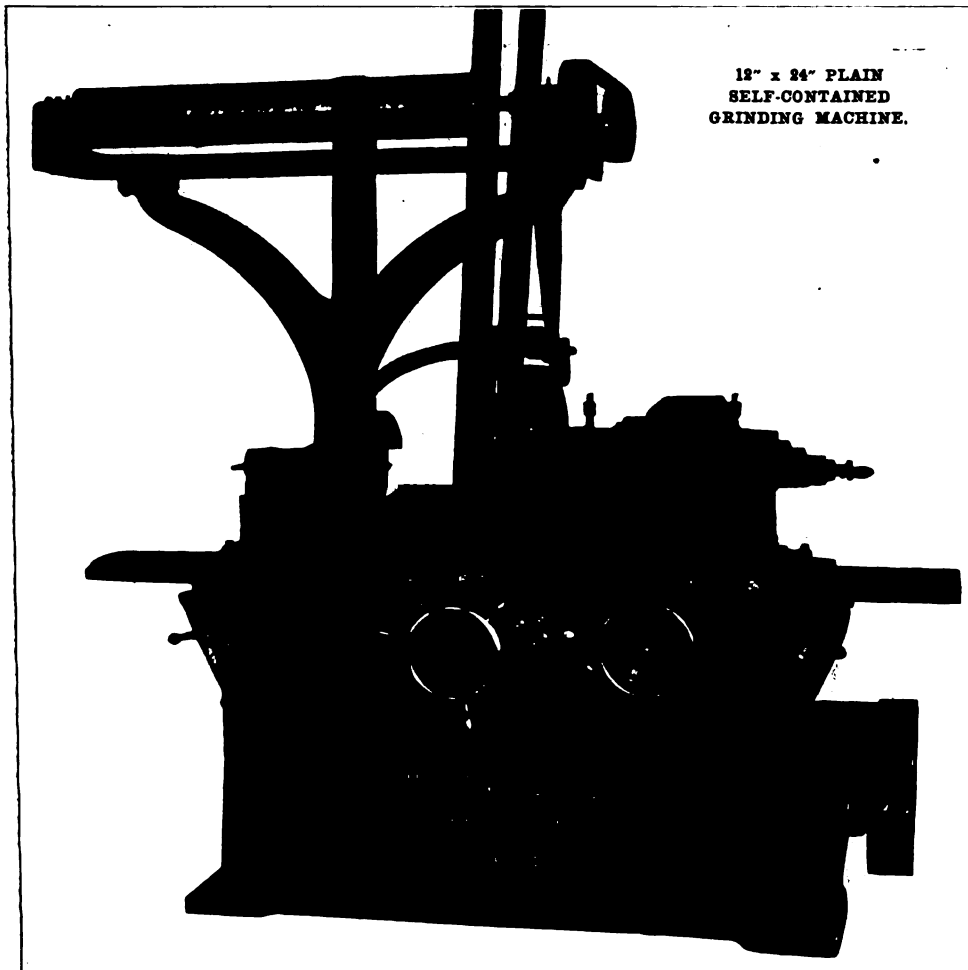

12" x 24" PLAIN
SELF-CONTAINED
GRINDING MACHINE.

Absolute central control—all levers and hand wheels concentrated on front of Machine—quickly and easily operated. Work speeds and table feeds entirely independent and cover every range within the capacity of the machine. These are derived from our patented single-unit speed-change mechanism. Automatic feed at either or both ends of table reverse — Auxiliary feed for bringing the wheel into work without traversing table — Positive stop provided when feeding the wheel by hand. Head Stock entirely belt driven. Steady rests that are universal in all their movements and have positive stops for grinding duplicate work. Interchangeable wheel centers — Large diameter wide face wheel with powerful drive.

Increased Outputs. Reduced Shop Costs

FERGUSON OIL FURNACES

THE RAILWAY MATERIALS COMPANY

RAILWAY EXCHANGE, CHICAGO

SINGER BLDG., NEW YORK



Making One Die Head Do the Work of Two

Every user of the **Landis Die** is demonstrating this fact and consequently has an advantage over the other fellow.

The reason is obviously due to the line contact between chaser and work which eliminates most of the friction at the cutting edge and makes it possible to operate the die at about double the speed ordinarily recommended by manufacturers of other dies.

There are many more features worthy of your consideration which are covered by our catalogue.

Copy on request.



LANDIS MACHINE CO., Inc., Waynesboro, Pa., U. S. A.

Just Any Grinding Wheel Wouldn't Do for This Job



The work is grinding hardened nickel-steel pinions. They had to have *the Right Wheel in the Right Place*.—Just any grinding wheel wouldn't do. They had to have *just the Right Wheel in the Right Place*. The grinding was done dry, so a clean, free, cool-cutting wheel was necessary. The wheel had to hold its shape and last long enough to effect an economy.

**THE WHEEL SELECTED FOR
THE JOB WAS AN ALOXITE
GRINDING WHEEL**

Carborundum Service is solving grinding problems in other plants—it can in yours.

THE CARBORUNDUM COMPANY
NIAGARA FALLS, N. Y.

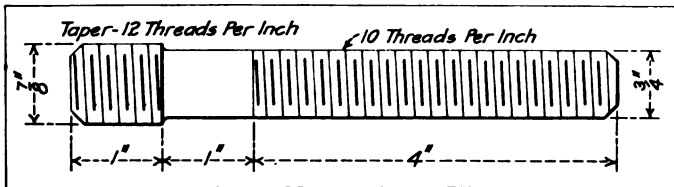
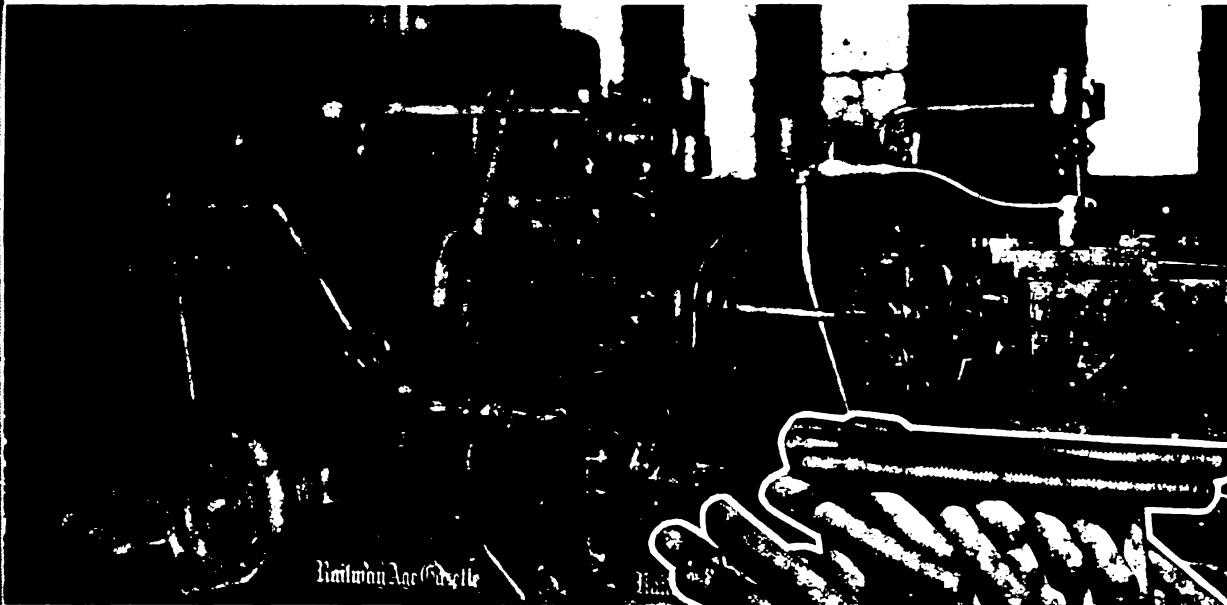

One Every Ten Minutes

THE throttle stem stuffing box studs shown above are produced at the rate of six studs per hour, sixty in an average day's work—another instance wherein railroad shop production is being materially increased by the use of the

No. 2-A Universal Hollow Hexagon Turret Lathe

The $\frac{7}{8}$ -inch round iron bar is turned to $\frac{3}{4}$ -inch diameter for a distance of 5 inches, the end chamfered, and the $\frac{3}{4}$ -inch thread cut. The piece is then cut off, rechucked, tapered, and threaded. The shop officials are highly pleased with the large output, which crowds neither the operator nor the machine.

One reason for the success of these machines in so many railroad shops is the ease with which they can be set up and changed over for short runs.

Investigate these machines now, so you'll be ready for prompt action at the right time.

THE WARNER & SWASEY COMPANY CLEVELAND, OHIO

New York Office: *Singer Bldg.*

Buffalo Office: *Iroquois Bldg.*

Boston Office: *Oliver Bldg.*

Detroit Office: *Ford Bldg.*

Chicago Office and Showrooms: *Nos. 618 to 622 West Washington Boulevard*

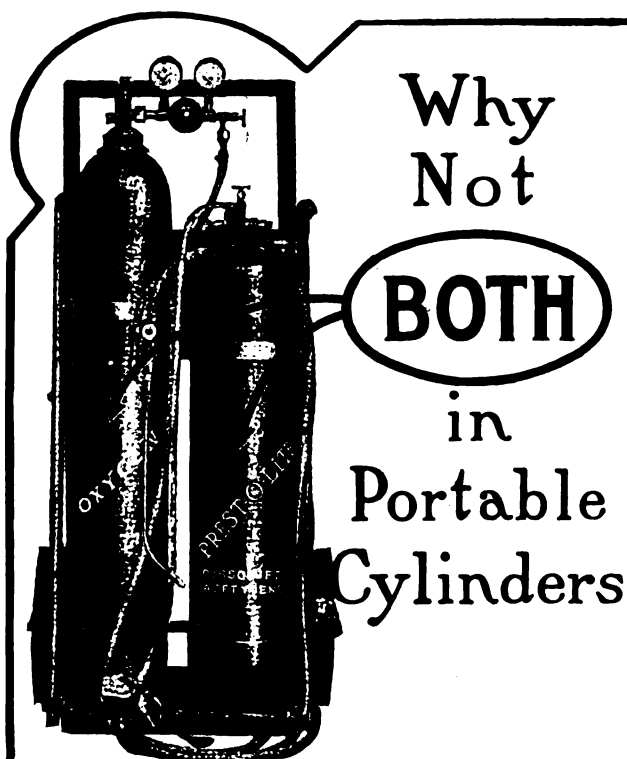

Why
Not
BOTH
in
Portable
Cylinders

A Complete Oxy-Acetylene Welding Plant That Is Truly Portable

The use of Prest-O-Lite Dissolved Acetylene with any make of Oxy-Acetylene welding or cutting apparatus provides large advantages in portability, economy, simplicity and highest efficiency. Effects important savings of time, labor and material in railway operation where sudden breakdowns of machinery and equipment are likely to occur at critical times. The complete welding plant is rushed to the spot and the repair made instantly without delays, dismantling or costly replacements.

We furnish a thoroughly high-grade welding apparatus for \$60, not including Acetylene cylinders, which are extra and are furnished under a liberal service plan. Truck and special equipment for cutting operations at extra cost.

PREST-O-LITE Dissolved Acetylene (Ready-made carbide gas)

Prest-O-Lite Acetylene Service furnishes the highest grade of Dissolved Acetylene in portable cylinders, used as conveniently as you use cylinders of oxygen. Saves the large initial outlay and heavy depreciation, trouble and inconvenience of making crude Acetylene in carbide generators. Beside, Prest-O-Lite Dissolved Acetylene is perfectly dried, cleaned and purified—makes better welds and is cheaper to use.

Write for our "Liberal Service Plan"—made possible by our facilities as the world's largest producers. If you use Acetylene for ANY PURPOSE, you should have our proposition on Prest-O-Lite Acetylene Service.

The Prest-O-Lite Co., Inc.
806 SPEEDWAY, INDIANAPOLIS, IND.

Direct factory branches and charging plants in principal industrial centers

METAL PLANERS

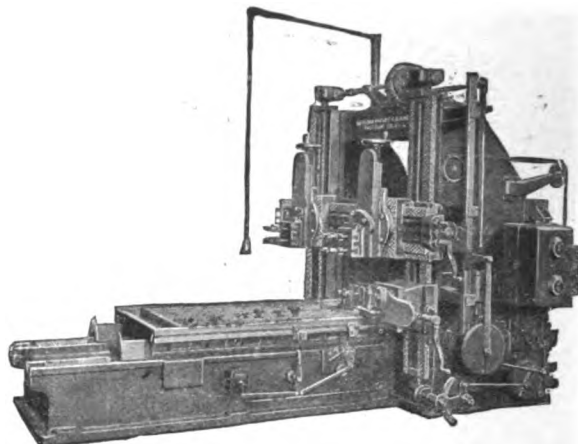

We manufacture three (3) distinct types.

- 1—Standard
- 2—Open Side
- 3—Convertible

Also Drilling and Bolt Threading Machinery

Send for Catalogue.

Detrick & Harvey Machine Co.
Baltimore, Md., U. S. A.

Beaudry Champion Hammer

Made with
rams weigh-
ing 50 to 500
lbs.

Is the ideal
general forging
hammer, and has
no equal on light
and heavy rail-
road, machine and
general forging.

It has a longer
stroke, a more
powerful blow and
a greater capacity
than any hammer
of the same rated
capacity or weight
of ram. It delivers
a maximum blow
of more than six
times the weight of
its ram.

We also
make the
**Beaudry
Peerless
Hammer**
in
sizes from
25 to 200
lbs.

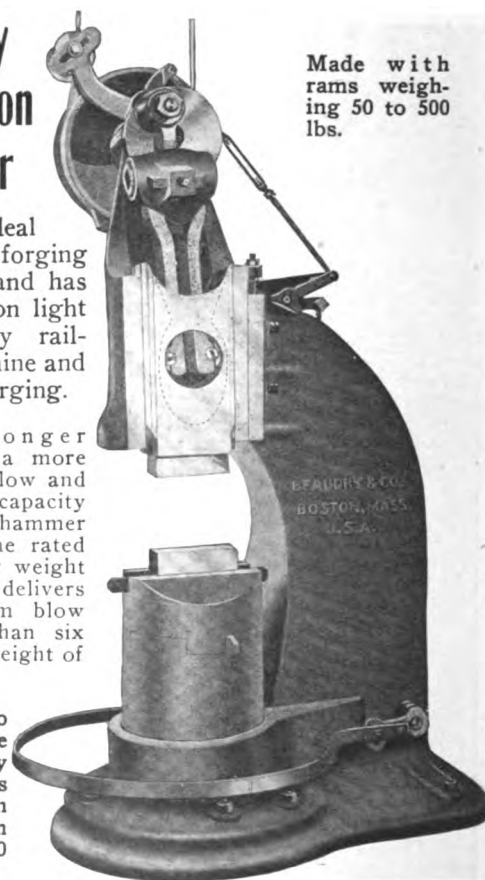

BEAUDRY & COMPANY, Inc., 141 Milk St., Boston, Mass.

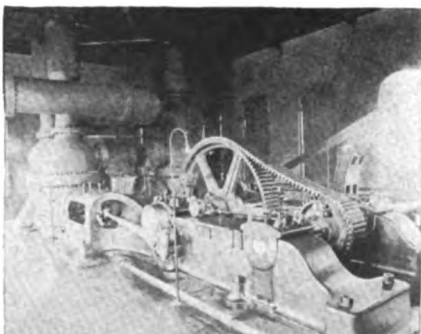
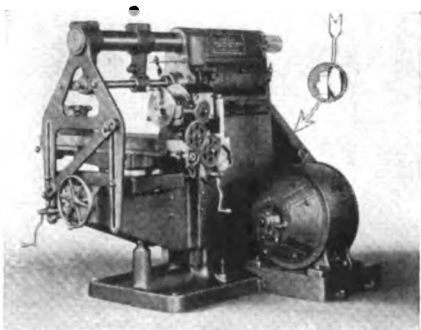
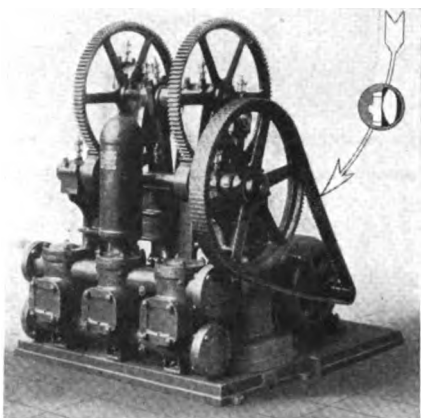
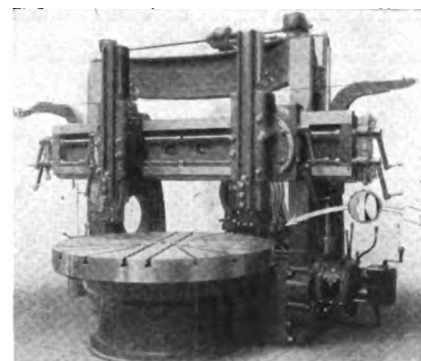
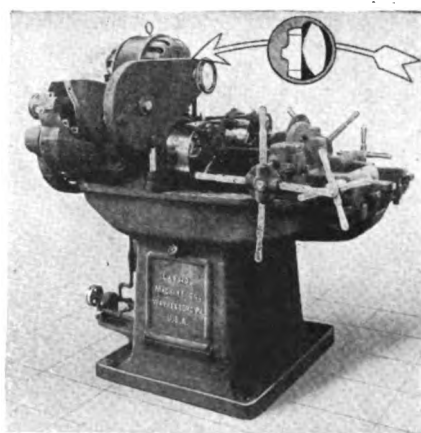
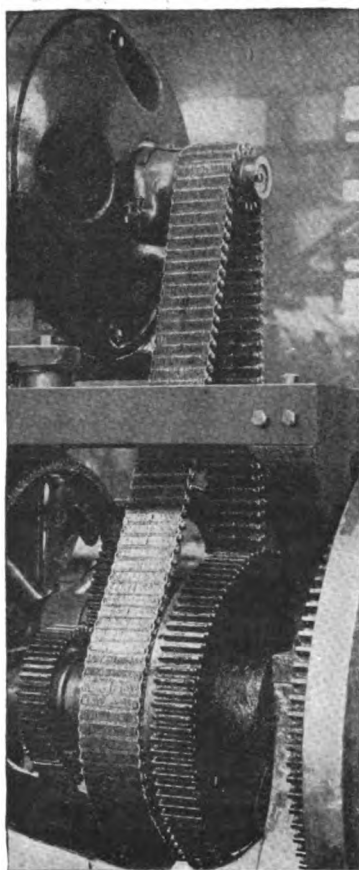
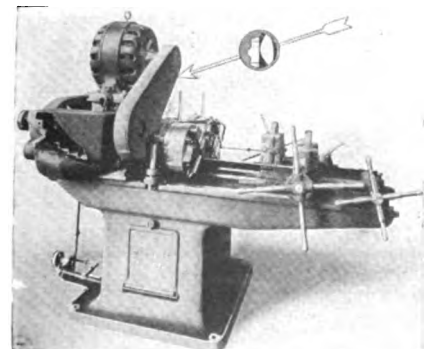
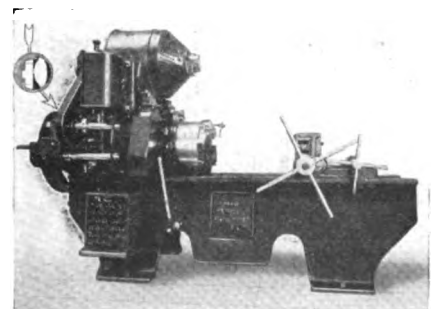
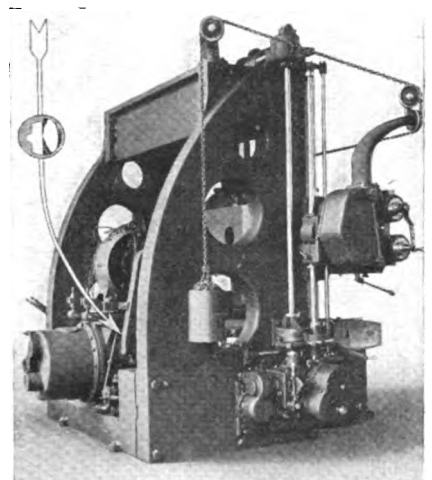
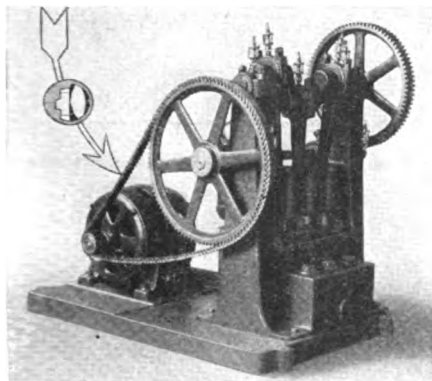
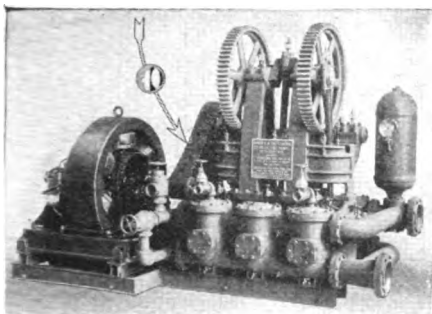

Application

MORSE Silent Chains can very easily be applied to almost any power machine without radical change in design.

Service

On machine tools, compressors, pumps, shafting, etc., the service given by MORSE Chains is uniformly good; they are quiet-running at high or low speed and free from ordinary transmission troubles.

Life

The central illustration above gives you an idea of the excellent condition of a MORSE Chain after more than 11 years' daily service (40 H.P. Lathe Drive). The average life of our chain drives is now about 5 or 6 years, or long enough for the drive to pay for itself, by its saving of power, about twice over.

In this advertisement, the pictures tell our story better than words. If you are in the market for a new machine, we will be glad to name a builder who will give you a MORSE Chain Driven Machine, or, if you simply want to rig up an old machine with chain drive, we will sell you direct. Why not let us hear from you NOW, when we can offer you special inducements in the way of price and delivery? Machine Builders can also buy in lots better now than for some time.

Morse Chain Company

Vest Pocket Size Publication No. 12 on the life of a chain drive is well worth having. Sent Free on Request.

Machine Tool Dept. B-59

Ithaca, N. Y.



PORTABLE TOOLS

*Cylinder Boring Bars, Milling Machines, Valve-seat Planers,
Radius Planers, Pipe Benders, Circular Planer Tools, etc.*

WRITE FOR CATALOG

H. B. UNDERWOOD & COMPANY

1029 HAMILTON STREET, PHILADELPHIA, PA.

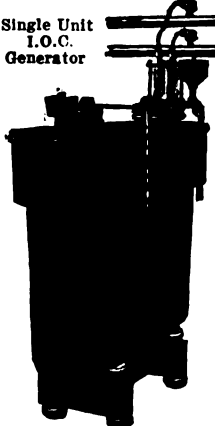

Single Unit
I.O.C.
Generator

Because of the absence

of detrimental impurities in the gases made by the



its use assures the most efficient flame for all cutting and welding purposes. The I. O. C. SYSTEM is automatic, safe, simple, and free from upkeep expense. We will be pleased to send full particulars with references, and quote on your particular needs.

International Oxygen Company

Works: NEWARK, N. J.
PITTSBURGH, Pa: Park Bldg.

General Sales Offices: 115 Broadway, NEW YORK CITY
PARIS, FRANCE: 40 Rue Laffitte

Ashton Wheel Press Recording Gages



Ashton Wheel Press Recording Gages give an accurate record of wheel fits on axles, showing actual fit from start to finish, insuring perfect mountings.

Send for special circular which gives full details, also catalogue describing our complete line of Specialties.

The Ashton Valve Co.

BOSTON, MASS. 271 Franklin St.	CHICAGO, ILL. 174 No. Market St.
-----------------------------------	-------------------------------------

ACORN DIE

AND HOLDER

**Increases production while
decreasing costs**



Ideal Adjustment
All the lands converge equally by turning the cap.

Perfect Support
to the cutting lands by the solid steel shell.

Independent lead
provided by the float.

Dies interchangeable
instantly, without changing adjustment of machine.

Send for illustrated circular giving the details of this interesting tool.

WILEY & RUSSELL MFG. CO., Div.

Greenfield Tap and Die Corporation
GREENFIELD, MASS.

New York 28 Warren St.	Philadelphia 38 N. Sixth St.	Chicago 18 South Clinton St.
---------------------------	---------------------------------	---------------------------------



Are You Studying Your Grinding Conditions?

Many a manufacturer is awakening to the need of studying the grinding conditions which affect the production and cost of grinding wheels.

With the Norton Company always ready to study your conditions, there is small excuse for the following frequent causes of high cost of operation and low quantity and quality of production:

- Wheel too hard—requiring too much dressing.
- Wheel too hard—causing undue wear on bearing boxes, thus producing vibration.
- Wheel too hard—causing loading followed by excessive heating and distortion of piece being ground.
- Improper speed of wheel—causing glazing or loading.
- Insufficient power so that wheel speed, when cutting, falls below recommended speed.
- Vibration of machine spindle—producing chatters and excessive wheel wear.
- Improper relation of wheel speed to work speed—the most common, and the least understood, cause of complaint against grinding wheels in cylindrical grinding.
- Improper or inadequate truing of wheel—a common cause of poor production and poor finish.
- Insufficient lubrication—a frequent cause of trouble in some classes of grinding.

Under correct conditions, an Alundum wheel for steel or a Crystolon wheel for cast iron and bronze will always show their superiority.

New York Store
151 Chambers Street

Chicago Store
11 North Jefferson Street



Hydraulic Press for Forcing Car Wheels On and Off

This press is widely used in railroad shops for forcing wheels on and off axles and for various other kinds of forcing work.

There is a great deal of satisfaction in operating one of our hydraulic wheel presses because of the convenience it affords; and also because of the reliability and accuracy of work which it performs.

The accompanying illustration is merely one of the hydraulic tools we manufacture for railroad shops. Send us your inquiry for any kind of hydraulic equipment. We are especially equipped to handle anything required "For Your Pressing Needs."

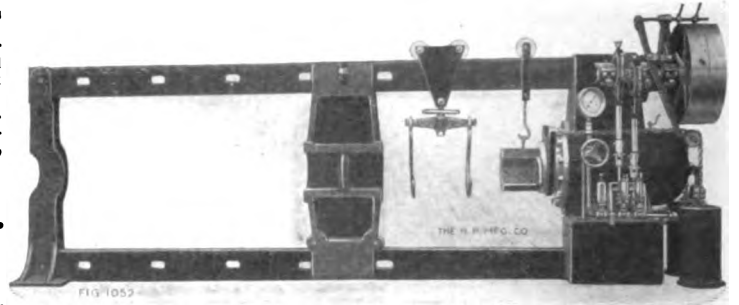

The Hydraulic Press Mfg. Co.

75 Lincoln Ave., Mount Gilead, Ohio

EASTERN OFFICE:

Room 1105-S. - - 39-41 Cortlandt Street, New York City

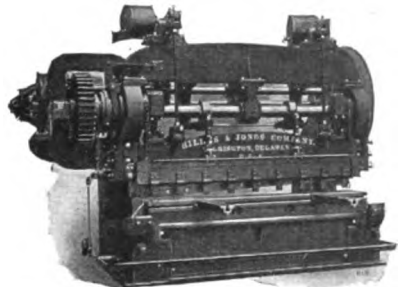

Guillotine Plate Shears. Capacity, 1/4" to 1 1/2". No overhung gearing. Automatic Stop and Hold-down.

Shearing Machinery

- ROTARY BEVEL SHEARS
- DOUBLE ANGLE SHEARS
- GUILLOTINE BAR SHEARS
- ALLIGATOR SHEARS

We also manufacture modern designs of: Punches, Plate Straightening Rolls, Plate Bending Rolls, Plate Planers, Rail Straighteners, Flanging Clamps.

Established 1854.

HILLES & JONES COMPANY, Wilmington, Del.

Pittsburgh Office, 201 Oliver Bldg.

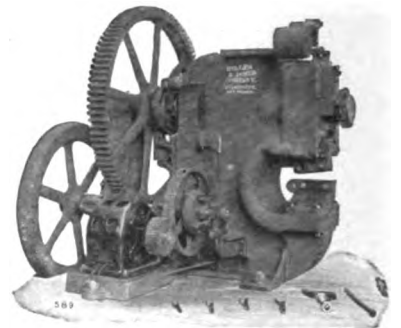

Vertical Open Throat Bar Shears. All sizes. Cam shaft bearings bronze bushed. Driving shaft easily removed without disturbing gears or keys.



It Grips and Never Slips

A grip without a slip, that's the Shaw Wrench! It can't let go until you do. Besides, the Shaw Wrench requires no adjusting. It's a time- and money-saver. Order

The Shaw Wrench

today and then give it a fair trial. Test it on steel rods, round-headed bolts, pipes, square and hex-nuts. A try means a buy! Made in one piece, bevel-jawed, designed to grip and move the most stubborn nut, the Shaw Wrench will measure up to every standard. Takes the place of Stillson, monkey, alligator or flat wrenches. Use it once and you will agree that the Shaw Wrench grips and never slips. Sizes and prices furnished on request.

SHAW PROPELLER CO.

131 State Street,

Boston, Mass.



"Here's Old Reliable, Bill"

When the stubborn nut falls to give, when other wrenches slip, the skilled mechanic calls for

The "Coes" Wrench

The railway man knows that no matter how tight the nut, the Coes Wrench takes hold—all that's needed is an adjustment of the semi-steel jaws and then a pull.

That's why 80,000 dozen "Coes" wrenches are moving millions of stubborn nuts every year. And while each "Coes" does cost 5% more, yet there is 30% longer service built into it. Insist on "Coes" Wrenches, then you will know why railway men swear by the "Coes."

COES WRENCH COMPANY

WORCESTER, MASS.

Shops of Prominent Railroads Driven by G-E Motors

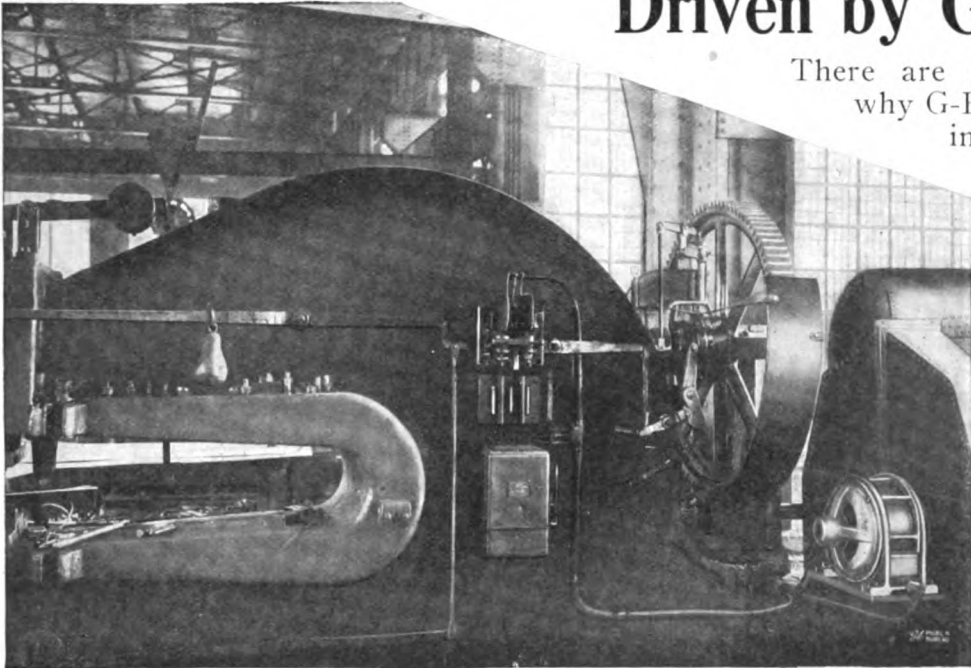

There are good sound reasons why G-E Motor Drive is used in the shops of such railroads as the:—

- New York Central
- Big Four
- Great Northern
- Florida East Coast
- Seaboard Air Line
- Boston and Albany
- Chicago, Burlington & Quincy
- Wabash
- Union Pacific
- Delaware, Lackawanna & Western
- Buffalo, Rochester & Pittsburg
- Norfolk & Western
- Oregon, Washington Railway and Navigation Co.
- Chesapeake & Ohio
- Pennsylvania
- Illinois Central
- Louisville & Nashville

7 1/2 H. P. Induction Motor Driving Boiler Punch Press, G. C. C. and St. L. R. R. Company, Beech Grove, Ind., Shops.

- Georgia Southern & Florida.
- Boston & Maine
- Aurora, Elgin & Chicago
- Chicago & Northwestern
- New York, New Haven & Hartford
- Southern Pacific
- Delaware & Hudson
- Pittsburgh & Lake Erie
- Atchison, Topeka & Santa Fe
- Chicago, Rock Island & Pacific, etc.

These reasons include an actual increase in flexibility and output; saving in coal and labor for operating plant as well as greater reliability, safety and efficiency.

The results obtained at one of the shops through the use of Curtis Steam Turbines and G-E Motor Drive are representative:

- Coal Saving, 50%
- Labor for power plant saved, 66 2-3%
- Output increased over 50%

With G-E Motor Drive machines can be arranged entirely independent of power considerations with perfectly clear overhead space for crane operation. They are often mounted on wheels or clamped to an iron floor near the work—machine moved to work instead of work to machine. This electric fan portability is a great convenience and time saver.

Departments as well as machines can be shut down or started up independently and the exact power cost of each is known at all times.

A bulletin describing the equipment of prominent railroad shops will be sent on application.

General Electric Company

- Atlanta, Ga.
- Baltimore, Md.
- Birmingham, Ala.
- Boston, Mass.
- Buffalo, N. Y.
- Butte, Mont.
- Charleston, W. Va.
- Charlotte, N. C.
- Chattanooga, Tenn.
- Chicago, Ill.
- Cincinnati, Ohio
- Cleveland, Ohio
- Columbus, Ohio
- Dayton, Ohio
- Denver, Colo.
- Des Moines, Iowa
- Detroit, Mich.
- (Office of Agent)
- Duluth, Minn.
- Elmira, N. Y.
- Erle, Pa.
- Fort Wayne, Ind.
- Indianapolis, Ind.
- Jacksonville, Fla.

General Office: Schenectady, N.Y.

ADDRESS NEAREST OFFICE

- Joplin, Mo.
- Kansas City, Mo.
- Knoxville, Tenn.
- Los Angeles, Cal.



- Louisville, Ky.
- Memphis, Tenn.
- Milwaukee, Wis.
- Minneapolis, Minn.

- Nashville, Tenn.
- New Haven, Conn.
- New Orleans, La.
- New York, N. Y.
- Niagara Falls, N. Y.
- Omaha, Neb.
- Philadelphia, Pa.
- Pittsburg, Pa.
- Portland, Ore.
- Providence, R. I.
- Richmond, Va.
- Rochester, N. Y.

- St. Louis, Mo.
- Salt Lake City, Utah
- San Francisco, Cal.
- Schenectady, N. Y.
- Seattle, Wash.
- Spokane, Wash.
- Springfield, Mass.
- Syracuse, N. Y.
- Toledo, Ohio
- Washington, D. C.
- Youngstown, Ohio

For Texas, Oklahoma and Arizona business refer to Southwest General Electric Company (formerly Hobson Electric Co.), Dallas, El Paso, Houston and Oklahoma City. For Canadian business refer to Canadian General Electric Company, Ltd., Toronto, Ont.



TO our friends, and to those of whom
we expect to make friends through
service, we extend our expressions of
hearty good will and wishes for a Bright
and Prosperous New Year.

The Bullard Machine Tool Co.
Bridgeport, Conn. U. S. A.

The Figures Tell the Story

cash, while group of w... at Washington... or de... nan-
 nt... of their c... for... At s... inue.
 certain... v... Pick... we read that
 of af... vs. Pick... wit' the... "opening
 "w... ch... hat... it
 ve... it
 n... rk... apply to... I
 and remember... who
 you the affliction.

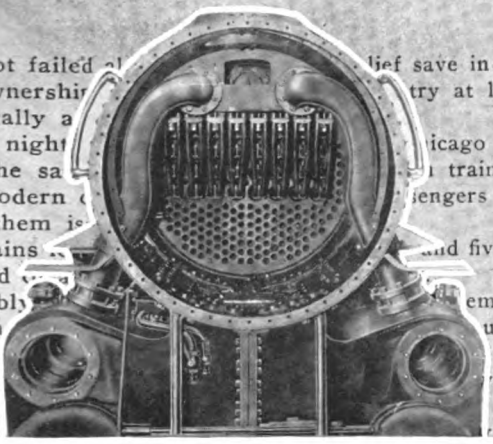

The Figures Tell the Story

In the table given opposite, the locomotives used in each class were of the same dimensions, but the Mikado engines were equipped with superheaters.

It will be noted from the table that the Mikado type engines performed a greater mileage, handled greater gross ton miles, operated at lower cost per 100 gross ton miles and consumed less coal per engine mile than either of the other two types of engines.

This saving effected is largely accounted for by the use of the

Schmidt Superheater

When the maintenance cost is calculated on the productive ability of the locomotives on the ton mile basis, it is found to be less than that of saturated locomotives of the same dimensions.

These are the facts and figures that prove the advantages gained by installing the Schmidt Superheater in existing as well as new locomotives.

Let us submit designs for your existing types of locomotives.

LOCOMOTIVE SUPERHEATER CO.

New York Chicago
 30 Church St. Peoples Gas Bldg.

LOCOMOTIVE PERFORMANCE ON THE CHICAGO GREAT WESTERN

The Chicago Great Western has made a very interesting comparison of the performance of 10 Consolidation, 10 Mallet and 10 Mikado locomotives during the 12 months ending March 31, 1914, with a view of determining which class of engines proved to be the most efficient. These 30 engines were operated over the Eastern division between Stockton, Ill., and Oelwein, Iowa, under as nearly comparable conditions as possible throughout the 12 months. A careful record was kept of the mileage, tons hauled, operating expenses and repair expenses, together with the amount of coal consumed, these figures being included in the accompanying table.

AVERAGE PERFORMANCE OF TEN LOCOMOTIVES IN EACH CLASS FOR 12 MONTHS ENDING MARCH 31, 1914

Class of locomotive	Consolidation	Mallet	Mikado
Total mileage	20,609.8	14,035.8	33,764.8
Operating expenses*	9,170.42	7,463.77	13,944.64
Running repairs**	1,543.30	1,448.68	2,971.96
Shop repairs	1,196.86	2,528.34	1,944.67
Total repairs	2,740.16	3,977.02	4,916.63
Total operating expense and repairs	11,910.58	11,440.79	18,861.27
Coal consumed (tons)	3,124.5	2,509.9	4,746.4
Potential ton miles	34,045.35	27,296.555	71,555.205
Gross ton miles (incl. lading and cars)	24,819.20	22,876.360	62,195,000
Percentage of gross to potential ton miles	73.0	83.9	86.9
Gross tons per mile	1,204.3	1,902.5	1,842.0
Coal consumed per 100 gross ton miles (lb.)	24.11	19.79	15.22
Coal consumed per engine mile (lb.)	303.21	357.64	281.14
Cost per 100 gross ton miles (cents)	4.35	4.32	3.02
Cost per engine mile (cents)	57.79	81.77	55.86
Cost of maintenance—			
Per 100 gross ton miles (cents)	1.102	1.752	0.687
Per engine mile (cents)	13.30	28.60	14.35
Per work unit† (dollars)	2.85	3.52	2.65
Per road unit†† (dollars)	66.8	93.1	66.8

*Includes engine men, enginehouse expenses, fuel, lubricants and other supplies.
 **Includes running repairs made at Oelwein shops and at other points.
 †Work unit equals tractive effort multiplied by locomotive miles, divided by 1,000,000.
 ††Road unit equals weight on drivers in pounds multiplied by locomotive miles and divided by 100,000,000.

Notes—The figure for shop repairs for the Consolidation engines is based on the average cost of the repairs of all Consolidation engines and divided, owing to the credit of the Mikado type engine. These two sets of figures show, perhaps, to better advantage the actual cost of operation of the different types of locomotives. Without a doubt, a large part of the savings made by the Mikado type engine is accounted for by the use of the superheater. However...

To me it seems perfectly clear that the present system under which private individuals are expected to furnish the

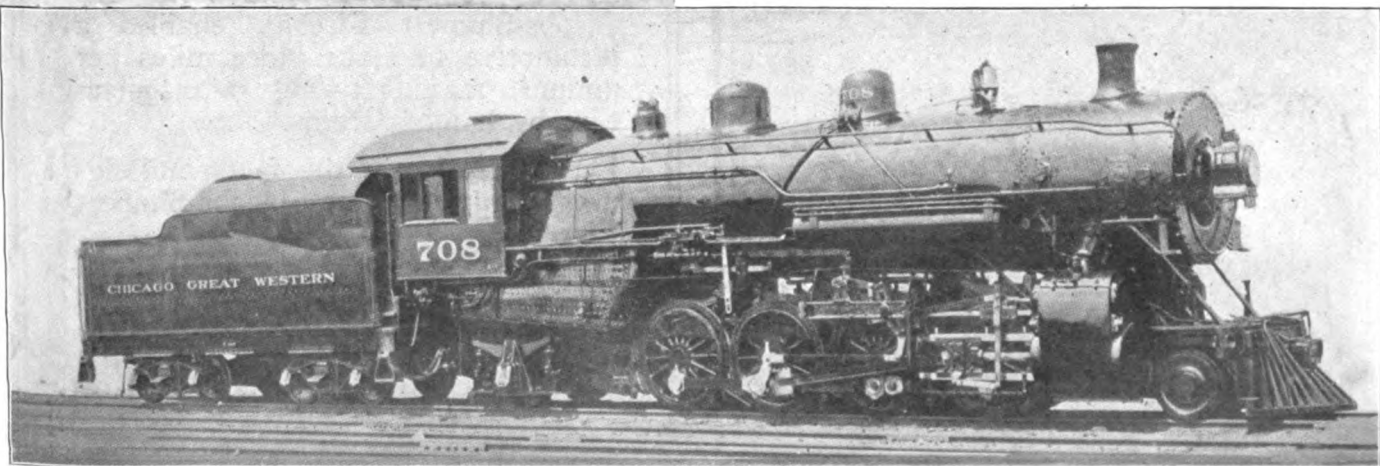

Sectional View of Lubricator Body.

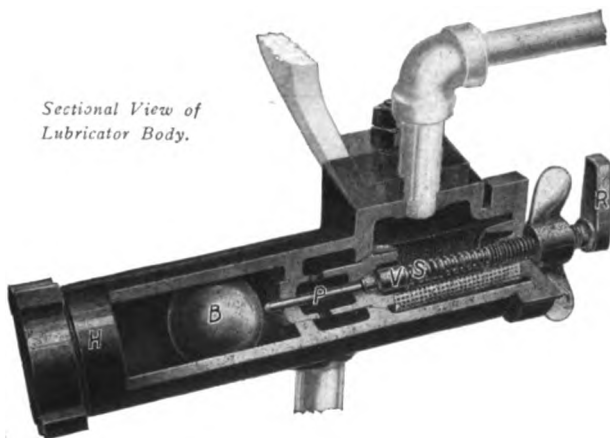

Another Step Toward Efficiency

The New Detroit Flange Lubricator is just another step toward efficiency expressed in dollars and cents. Its use means a direct saving in increased wear for your tires. Its installation means no extra work for the man in the cab. The

New Detroit Flange Lubricator

is absolutely automatic. It gives efficient flange lubrication just when it is needed; the feed is governed entirely by the requirements of the service.

The New Detroit Flange Lubricator consists of an oil reservoir and a feed nozzle on the flange; between these is the lubricator body with a ball valve controlling the feed of oil from the tanks to the flange. The lateral thrust of the engine moves the ball "B." against the plunger "P," this opens valve. This allows oil to reach the flange.

Its use means another step toward efficiency. For the inside facts, write for Catalog FO-84. A request letter will bring a copy.

DETROIT LUBRICATOR COMPANY

DETROIT, U. S. A.

Largest manufacturers of lubricating devices in the world.

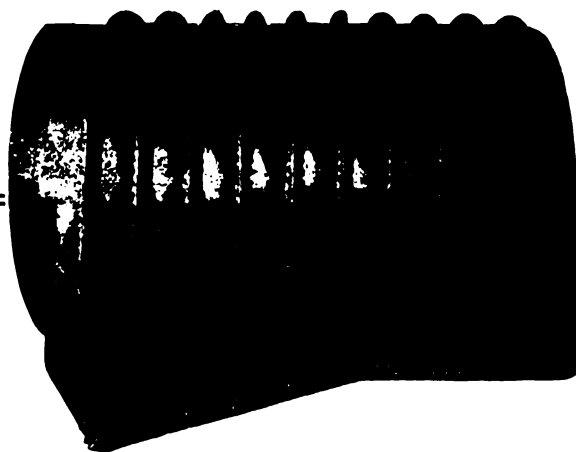
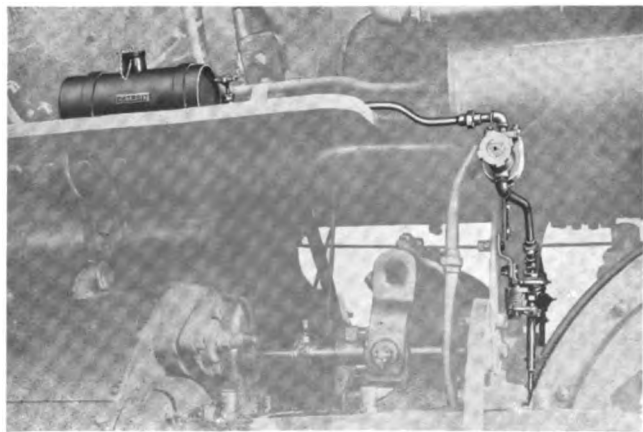

Advantages Of Jacobs-Shupert Firebox

FIREBOX FACT NO. 9

The value of freight engine service ranges from \$25.00 to \$100.00 a day. Every day that an engine is shopped for firebox repairs is a heavy item of expense; not only loss from service, but maintenance cost.

Can these losses be stopped? Can they be reduced? Investigate the

JACOBS-SHUPERT FIREBOX

There are no staybolts to break and cause delay. The Jacobs-Shupert Firebox is a series of units, every one of which within itself is stable and self-supporting. If a rupture should occur in one section it could not extend beyond that section into another.

By reducing the danger of explosions and by eliminating staybolts, the Jacobs-Shupert Firebox enables a locomotive to make more miles per annum manufacturing transportation by hauling trains.

Let us send you the facts and figures regarding the Jacobs-Shupert Firebox.

The Jacobs-Shupert U. S. Firebox Co.

30 CHURCH STREET, NEW YORK
WORKS—COATESVILLE, PA.

3100 INDICATED HORSE-POWER

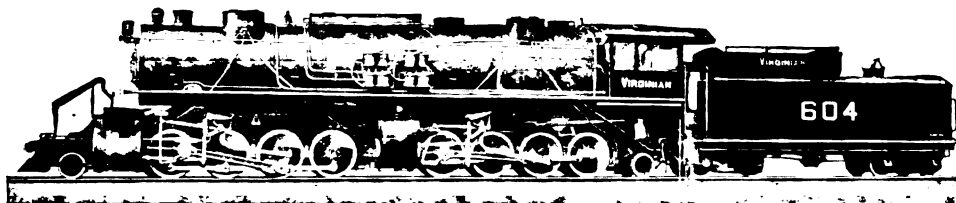

Total weight of engine, 540,000 pounds; weight on drivers, 480,000 pounds; diameter of drivers, 56 inches; boiler pressure, 200 pounds; cylinders, 28 and 44 x 32 inches; maximum tractive power, 115,000 pounds.

Mallet locomotives designed for Virginian Railway for pusher service on a 2.07 per cent grade, with 115,000 pounds tractive power working compound, have proven themselves capable of handling a train of 7,180 tons on a 0.6 per cent grade, requiring a draw-bar pull of approximately 110,000 pounds.

3100 indicated horse-power was developed on a 0.2 per cent grade at a speed of 21½ miles per hour.

AMERICAN LOCOMOTIVE COMPANY
30 CHURCH STREET, NEW YORK

The Value of Good-Will

Every student who ever left the X—University knew Mr. Sellers, the congenial book salesman. Wasn't it Mr. Sellers who advised with Freshman and evinced a brotherly interest in the future of all seniors? They spoke of Sellers like speaking of a boon companion. Naturally, Mr. Sellers was never forgotten.

Some years later Mr. Sellers decided to publish a book. Every salesman who called on an old "Grad" said: "I represent Mr. Sellers." The business founded on good-will flourished.

Financial difficulties, however, forced Mr. Sellers to retire from the publishing field. An aggressive business associate decided to take over the business. He changed the name of the firm. Then began an uphill fight to establish the new company.

At the end of one year, the brisk, aggressive associate who forgot the value of a name engaged Mr. Sellers at \$5,000 a year just for the use of his name.

If you are an advertiser, it will pay you to build up the business of good-will. Consistent advertising builds up good-will—the strongest foundation on which to build a business organization.

Railway Age Gazette
Mechanical Edition

Members of the Audit Bureau of Circulations

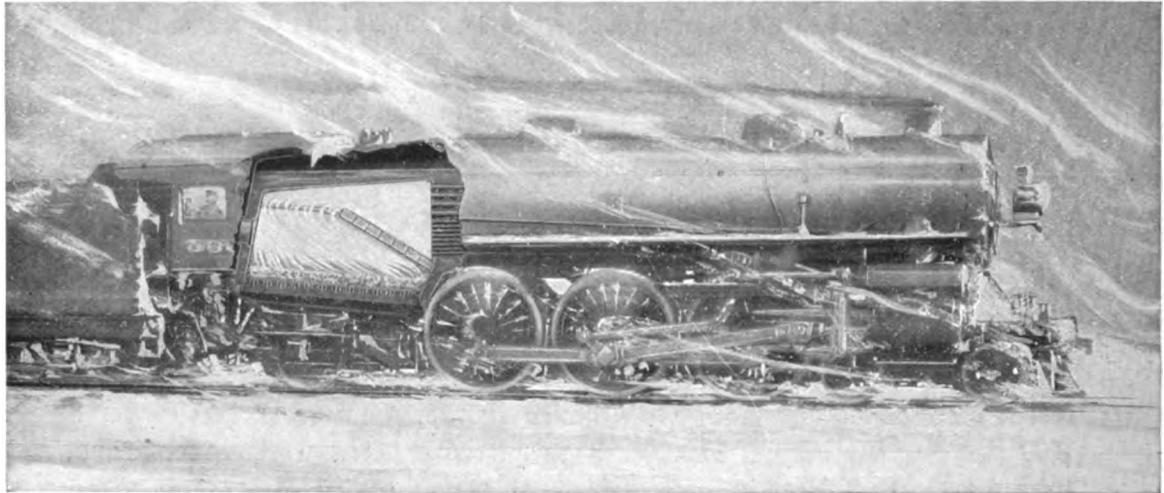

ADVANCE

Progressive railroads stand out prominently because they are making headway in improvements. They are marching, advancing, rising. They are ground-gaining, forward-moving institutions, doing better work and giving better service to-day than they did yesterday. You know the roads. They are Security Sectional Arch roads, every one of them.

AMERICAN ARCH COMPANY

30 CHURCH STREET, NEW YORK
McCORMICK BUILDING, CHICAGO

MIKADOS EFFECT ECONOMIES



Consolidation Type Locomotive, Chicago, Great Western Ry.

CYLINDERS—24 x 30 inches.
DRIVING-WHEELS, DIAM.—63 inches.

WEIGHT, TOTAL ENGINE—216,000 lbs.
TRACTIVE FORCE—46,500 lbs.

The Chicago Great Western Ry. recently conducted a test of several types of freight locomotives, extending over a period of twelve months. This test was made on the Eastern Division, where the ruling grades are one per cent. The engines tested included ten of the Consolidation type, using saturated steam, and ten of the Mikado type, using superheated steam. These locomotives were built by The Baldwin Locomotive Works in 1909 and 1912 respectively. The Mikado type engines were given the preference in fast freight runs, which accounts largely for the difference in mileage as shown in the following table:

	Consolidation	Mikado
Total mileage	20,609.8	33,764.8
Coal consumed, tons	3124.5	4746.4
Gross ton miles	24,819,920	62,195,000
Gross tons per mile	1204.3	1842.0
Coal per 100 gross ton miles, pounds	24.11	15.22
Coal per engine mile, pounds	303.21	281.14
Cost of maintenance per 100 gross ton miles (cents)	1.102	0.687

The Mikado type locomotives hauled, on an average, 53 per cent more tonnage per train than the Consolidations, but burned 6 1-2 per cent less coal per engine mile. On a gross ton mile basis, the Mikados saved 37 per cent in pounds of coal consumed, and 38 per cent in cost of maintenance. Important savings are being effected on many roads by the use of heavy motive power of improved design.

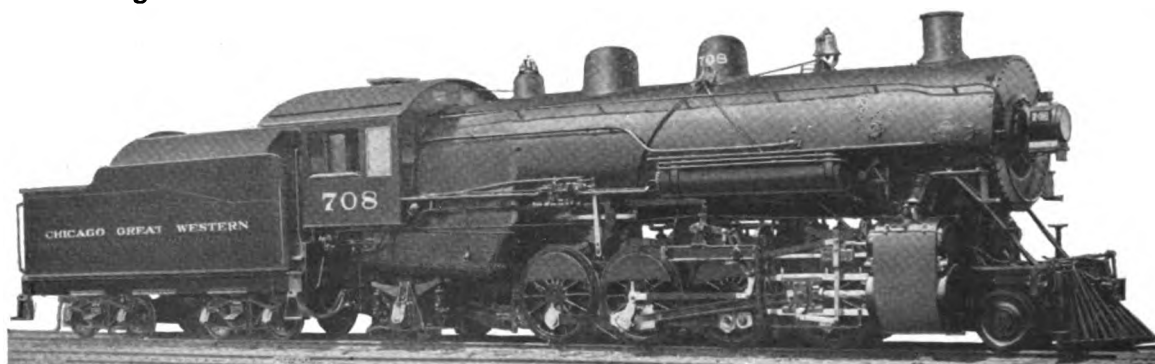

Mikado Type Locomotive, Chicago Great Western Ry.

G. M. Crownover, Supt. Motive Power.

CYLINDERS—27 x 30 inches.
DRIVING-WHEELS, DIAM.—63 inches.

WEIGHT, TOTAL ENGINE—283,100 lbs.
TRACTIVE FORCE—54,600 lbs.

THE BALDWIN LOCOMOTIVE WORKS PHILADELPHIA, PA., U. S. A.

Represented by

F. W. Weston, 50 Church St., New York, N. Y.

A. Wm. Hinger, 722 Spalding Building, Portland, Ore.

C. H. Peterson, 1610 Wright Building, St. Louis, Mo.

Charles Riddell, 625 Railway Exchange, Chicago, Ill.

George F. Jones, 407 Travelers Building, Richmond, Va.

Cable Address: "BALDWIN, PHILADELPHIA."

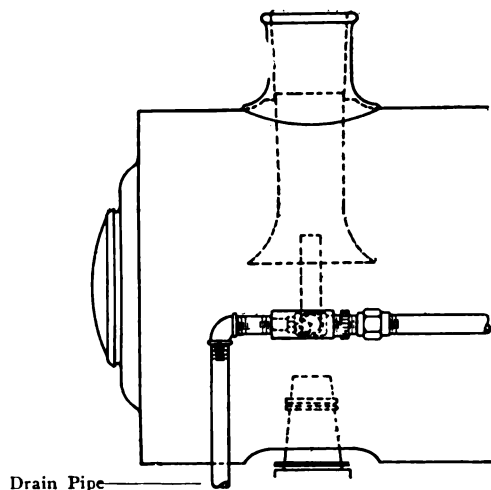

Keep Water Out Of The Blower Pipe

All condensation in the blower pipe is automatically drained, whether standing or running, by the use of the

Watertown Blower Pipe Drain Fitting

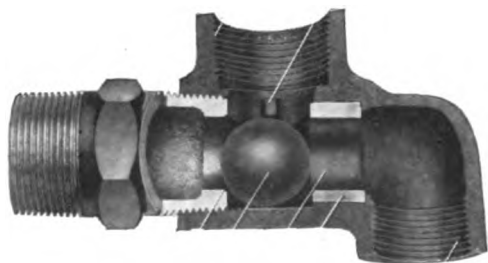

The fitting is installed at the lowest point in the blower pipe, ordinarily at the turn off into the smoke box, as shown in the diagram, and acts automatically with the opening and closing of the blower valve. When the valve is opened the ball closes the drain port and all steam passes into the smoke box nipple. As soon as the valve is closed the ball is unseated and all condensation in the blower pipe is carried off through the drain pipe.

The fitting also serves to do away with the plug used to close the round house hose connection as described in the circular. It has been tried out by several of the large roads for long periods and has proved efficient under all conditions.

By its use all freezing of the blower pipe and soiling of the clothes of bystanders is done away with. A postal brings a descriptive circular.

Manufactured by

Watertown Specialty Company,
Watertown, N. Y.

Distributors

DIAMOND SPECIALTY & SUPPLY CO.,
Harrison Bldg., Philadelphia, Pa.

Oil Troubles Solved Oil Costs Reduced

Our skilled force of mechanical experts and chemists is at the service of railroad managers for consultation regarding oils. They solve all oil problems, both lubricating and signal, and will advise which of these oils is best adapted for a particular purpose:

Galena Coach, Engine and Car Oils
Sibley's Perfection Valve Oils
Perfection Signal Oil
Galena Railway Safety Oil

When investigation shows that conditions warrant it, we make a guarantee cost per thousand miles for from one to five years.

Write us fully—we will gladly answer all your oil questions.

Galena-Signal Oil Company
Franklin, Pa.

1

Double Boiler Check Valve

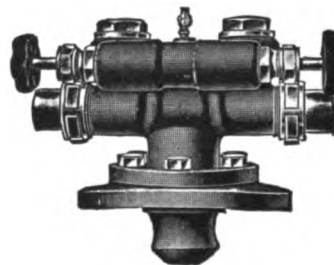

The position of this valve is on top of the boiler. It is provided with a stop valve for each check valve, so that either one of the check valves, if out of order, may be "cut out" without interfering with the feeding of the boiler. Removable caps on top of each check permit inspection and grinding of valves without disconnecting pipes.

Simple and pleasing design, compact and efficient. Furnished complete with boiler flange.

Write for Catalog



Western Office: 1612 Old Colony Building, Chicago
St. Louis Office: Frisco Building

DIXON'S GRAPHITE AIR BRAKE LUBRICANTS

For Brake Cylinders

Use Dixon's Graphite Air Brake and Triple Valve Grease — a heat-proof, cold-proof grease-and-graphite mixture that keeps the leathers in perfect condition, and gives uniform sensitiveness and quick response to control which mean greater safety and dependability.

For Triple Valves

Use Dixon's Air Brake Graphite—a grade of special fineness and uniformity—wherever dry graphite is specified. Use Dixon's Graphite Triple Valve Grease for parts requiring a semi-fluid lubricant. In either case, you get results to be had only with the genuine selected flake graphite as made by Dixon.

For Piping

Use Dixon's Graphite Pipe Joint Compound and save pipe, fittings and labor. The graphite lubricates the threads and gives an absolutely tight joint that never hardens or sets and which can easily be opened at any time.

Send for the text book on maintenance economy,
"Graphite Products For The Railroad", No. 7

Made in JERSEY CITY, N. J., by the

Joseph Dixon Crucible Company

ESTABLISHED 1827

Jenkins Bros. Valves

Specifying Jenkins Bros. means freedom from valve troubles.

Means getting the original renewable disc valves fitted with the genuine Jenkins Bros. Discs.

Body, Trimmings and all working parts strong, and well proportioned.

Write for Catalogue



Look for the Trade Mark

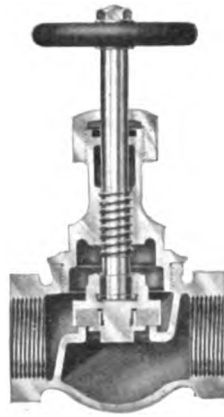

For Longest Service

Valves made of a superior grade of new steam metal. (No scrap or yellow brass.)

Complete Valves seldom wear out. Repair parts obtainable when necessary through your dealer at nominal cost. Every Valve Guaranteed.

Jenkins Bros., 80 White St., New York

Specify name in full—Jenkins Bros.

"The Light of Day on the Right of Way"



BOOKLET "H" ON REQUEST

Headlights

S. M. P. writes :

"Locomotives equipped with your type headlights have been in service quite a period affording excellent light and cost of maintenance most satisfactory."

Commercial Acetylene Railway Light & Signal Co.

80 Broadway, New York

Atlanta San Francisco Chicago Boston Toronto

GOULD COUPLER CO.

OFFICES: 30 EAST 42d ST. N.Y.C. THE ROOKERY, CHICAGO DEPEW, N.Y.
WORKS: AXLE FORGE, DEPEW, N.Y. MALLEABLE IRON, DEPEW, N.Y. CAST STEEL, DEPEW, N.Y.

MANUFACTURERS OF

- Gould M. C. B. Couplers.
- Gould Vestibules, wide and narrow.
- Gould Continuous Platforms and Buffers for wood sills.
- Gould Continuous Platforms and Buffers with steel underframing.
- Gould Steel Platforms with Friction Buffers.
- Gould Friction Draft Gear for passenger equipment.
- Gould Trap-Door Rigging.
- Gould Journal Boxes.
- Gould Malleable Iron Draft Beams.
- Gould Twin Type of Draft Gears.
- Gould Tandem Type of Draft Gears.
- Malleable Iron Castings, scientifically annealed.
- Car and Engine Axles, wrought iron or open hearth steel.
- Truck Frames.
- Cast-Steel Bolsters.
- Cast-Steel End Sills.
- Steel Castings.
- Gould Friction Draft Gear.

Employment Bureau

Undisplayed advertisements are inserted in this column at two cents a word for the first insertion and one cent a word for each consecutive insertion of the same advertisement. Minimum charge \$1.00. Remittance must accompany each order.

Use This Space For Results

AMERICAN Companies seeking European representation should communicate at once with the undersigned (officer in the French Army) who has heretofore had large experience and acquaintance both in the Railway and Metal trades. United States references can be given. J. M. A. Gassmann, 9, Rue Raudin, Paris, France.

No one knows who you are or what you can do till you tell them, and telling them is what this space is for.

Railway Age Gazette, Mechanical Edition

NEW YORK
Woolworth Bldg.

CHICAGO
Transportation Bldg.

CLEVELAND
Citizens Bldg.

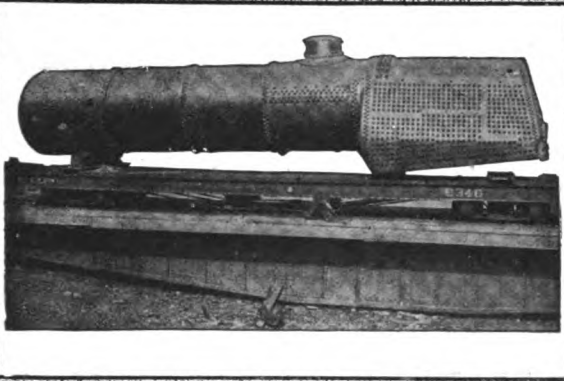

TATE FLEXIBLE STAYBOLTS

THE RECOGNIZED STANDARD FOR LOCOMOTIVE FIREBOXES

SERVICEABILITY PLUS ECONOMY

The Tate Bolt has fully demonstrated its true functions as a mechanical appliance to serve the fire box requirements. Flexibility must be maintained—the only positive assurance of flexibility is the use of the Tate Flexible Staybolt.

Many of the largest railroad systems have kept accurate service records and show remarkable increase in earning power of the locomotives that have been equipped with complete installations of the Tate Flexible Staybolt.

Flannery Bolt Company

PITTSBURGH, PA., U. S. A.

GEN'L OFFICES, VANADIUM BUILDING B. E. D. STAFFORD, GEN'L MANAGER
 J. ROGERS FLANNERY & COMPANY, SELLING AGENTS
 VANADIUM BUILDING, PITTSBURGH, PA.
 GEO. E. HOWARD, EASTERN TERRITORY W. H. WILSON, WESTERN TERRITORY
 COMMONWEALTH SUPPLY CO., SOUTHEASTERN TERRITORY
 CHARLES HYLAND, BOILER EXPERT

Air Brake Education

No. 6—What the Maintenance Man Should Know

AIR BRAKE Foremen, Repairmen, Test Rack Operators, Inspectors and similar employees constitute a large and very important class with the most definite and direct interest in Air Brake Work and Air Brake Education. The Maintenance Man, however, is primarily concerned with the structural features of air brake devices, the functions intended, the correct fitting and adjustment of parts, the flow of air through ports, passages and chambers, and the proper maximum and minimum variations, permissible leakage and wear, and all other conditions which determine whether the apparatus is safe and efficient for road service or otherwise.

Therefore, the Maintenance Man must first understand broadly the proper working of each air brake device, be able to determine the cause of any improper

action, and in general acquire a familiarity with individual functions as well as operation, when combined in the brake system as a whole.

In no sense, however, should the importance of the Maintenance Man be underestimated, since through him the efficiency of the brake equipment is maintained at a practical constant. The utmost skill and judgment of the Train Man can only partially compensate for brake equipment improperly repaired, carelessly tested and poorly maintained.

If the Maintenance Man will appreciate that a highly efficient brake system is one of the large factors affecting the earning capacity of his road, he will readily understand why *he* should study the Air Brake, and the specific phase of Air Brake Education which is of first importance to *him*.

(This is the sixth of a series of papers covering a practical review of the essential elements of Air Brake Education.)

Westinghouse Air Brake Company

Pittsburgh, Pa.

NEW YORK: City Investing Bldg.

CHICAGO: Ry. Exchange Bldg.

ST. LOUIS: Security Bldg.

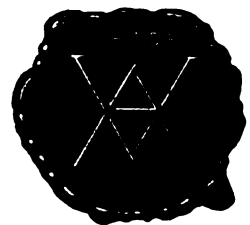

Use KRUPP STEEL the Best for All Purposes

How good, not how cheap. 100 years of steel making counts some.

Krupp makes almost anything in steel and machinery, from a battleship or 16-inch cannon to a coffee grinding mill.

If you have a problem, the answer is, no doubt, use better steel, or, use a better machine.

Send us, please, your inquiries and sketches

Thomas Prosser & Son 17 Gold Street New York



Ratchet Wheels Pawls and Plates

In high grade Malleable Iron
for use with

THE SQUARE BRAKE SHAFT

Conforming to Interstate Commerce Commission
Requirements

WRITE FOR CATALOGUE NO. 21

THE NATIONAL MALLEABLE CASTINGS CO.

CLEVELAND

CHICAGO

INDIANAPOLIS

TOLEDO

SHARON, PA.

MELROSE PARK, ILL.

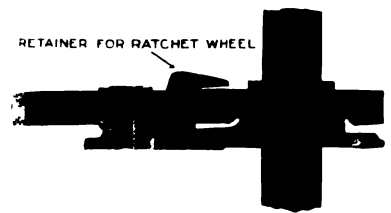

STUCKI SIDE BEARINGS

Reduce wheel flange
wear, rail wear and
train resistance

A. Stucki Co.
Oliver Bldg., Pittsburg, Pa.



Let Us Solve Your Ventilating Problem

Our experience in manufacturing "Globe" Ventilators and "Globe" Lamp Jacks will be invaluable to you in solving your ventilating problem.

The "GLOBE" LAMP JACK assures a clear steady flame. Air cannot enter the jack from the outside, due to its scientific construction. Your lamps will burn clear and steady no matter how fast your trains are running.

The "GLOBE" VENTILATOR assures frequent change of air—a strong outward draught and at the same time absolute freedom from storm and cinders. Our booklet will be mailed free of charge. Write today.

GLOBE VENTILATOR COMPANY
TROY, N. Y.

June Issue

Cardwell Friction Draft Gear

3—Description

The Cardwell Friction Draft Gear is a new type of draft gear which is designed to meet the requirements of modern service...

Union Draft Gear Company
McCormick Building
Chicago

July Issue

Cardwell Friction Draft Gear

3—Description

The Cardwell Friction Draft Gear is a new type of draft gear which is designed to meet the requirements of modern service...

Union Draft Gear Company
McCormick Building
Chicago

August Issue

Cardwell Friction Draft Gear

3—Description

The Cardwell Friction Draft Gear is a new type of draft gear which is designed to meet the requirements of modern service...

Union Draft Gear Company
McCormick Building
Chicago

September Issue

Cardwell Friction Draft Gear

3—Description

The Cardwell Friction Draft Gear is a new type of draft gear which is designed to meet the requirements of modern service...

Union Draft Gear Company
McCormick Building
Chicago

October Issue

Cardwell Friction Draft Gear

3—Description

The Cardwell Friction Draft Gear is a new type of draft gear which is designed to meet the requirements of modern service...

Union Draft Gear Company
McCormick Building
Chicago

November Issue

Cardwell Friction Draft Gear

3—Description

The Cardwell Friction Draft Gear is a new type of draft gear which is designed to meet the requirements of modern service...

Union Draft Gear Company
McCormick Building
Chicago

December Issue

Cardwell Friction Draft Gear

3—Description

The Cardwell Friction Draft Gear is a new type of draft gear which is designed to meet the requirements of modern service...

Union Draft Gear Company
McCormick Building
Chicago

Cardwell Friction Draft Gear

8—Capacity

The draft gear is confined to a space $12\frac{7}{8}$ " wide between the draft sills, and if a shock destroyer is confined within these limits, necessarily the amount of work which can be done is also limited. With the heavy shocks to which a car is subjected in modern service, it is impossible to construct, within these limits, a draft gear of sufficient capacity.

No draft gear confined between draft sills, within a space of $12\frac{7}{8}$ ", can accurately be called a shock destroyer.

The capacity of a draft gear depends to a certain extent upon its design, and to a certain extent upon its size. The largest draft gear, other things being equal, will do the largest amount of work. This is axiomatic and needs no proof. Therefore, the larger the draft gear, the larger its capacity for receiving and destroying shocks.

Union Draft Gear Company

McCormick Building

Chicago

Greetings

May the new year be one of peace and prosperity.

May every manufacturer realize that the tide has turned.

May restored confidence add a new zest to business and make each and everyone believe in the ultimate supremacy of industrial America.



We believe that the new era of prosperity, that is bound to follow, will convince every manufacturer that advertising is a vital part of every organization; that it raises prestige; builds good-will and brings buyer and manufacturer together. In short, to reach railway mechanical men, the men who are responsible for purchases of railway mechanical devices and equipment, it will require less than the cost of a postage stamp.

The Publisher

Railway Age Gazette

MECHANICAL EDITION

INCLUDING THE
AMERICAN ENGINEER

VOLUME 89, NUMBER 12.

ESTABLISHED IN 1832

NEW YORK: Woolworth Bldg.
CHICAGO: Transportation Bldg.

NEW YORK—DECEMBER, 1915—CHICAGO

CLEVELAND: Citizens Bldg.
LONDON (ENG.): Westminster

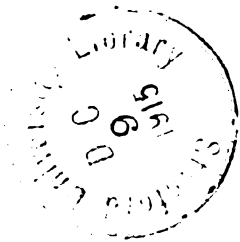

Our New Name

For some time we have realized that the name, *Railway Age Gazette, Mechanical Edition*, has been confusing; has failed to show that there is a distinction with a difference between it and the *Railway Age Gazette* (weekly). The latter, both in text and in advertising, covers the mechanical, as well as all of the other departments of railroading, from the operating point of view.

Railway Mechanical Engineer

To make the distinction between the two publications more marked, to make the name more synonymous with the contents, the *Railway Age Gazette, Mechanical Edition*, beginning January, 1916, will be called the *Railway Mechanical Engineer*.

That the *Railway Mechanical Engineer* is fulfilling its mission is attested by its steady growth in circulation and numerous unsolicited letters of commendation from railway mechanical department officers.

The growth in circulation of the *Railway Mechanical Engineer* is shown graphically by the chart on the outside back cover page of this issue.

The Publisher.

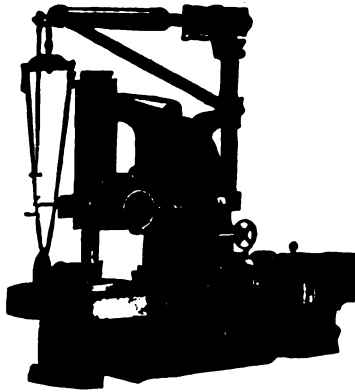

William Sellers & Co. Incorp.

PHILADELPHIA, PA.

The Sellers Car Wheel Borer automatically chucks, centers, and unchucks wheel. Starting table closes chuck. Reversing table opens chuck. **HARD LABOR OF CHUCKING AND UNCHUCKING ELIMINATED.** Geared feed instantly changeable from roughing to finishing. Air or geared hoist stops automatically at top and bottom of lift. Handles wheels from either side of machine.

Labor Saving Machine Tools ————— *Cranes* ————— *Injectors* ————— *Shafting*



You Want Results

That's why you need a Landis in your shop. The Landis die has proven many times that it will produce the greatest number of well-formed accurate threads at a minimum cost.

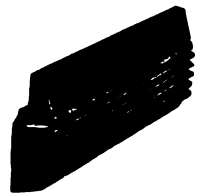

The long life, the permanent throat, the variable rake angle, are merely a few features of merit which deserve your consideration.

May we send you detailed information?

LANDIS MACHINE COMPANY

Waynesboro, Pa.

Don't Pound Your Sand Pipes

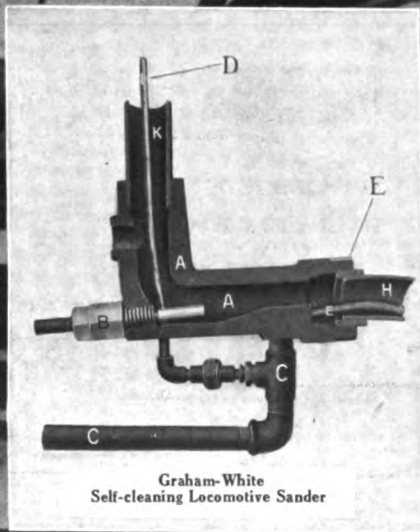

Graham-White Self-cleaning Locomotive Sander

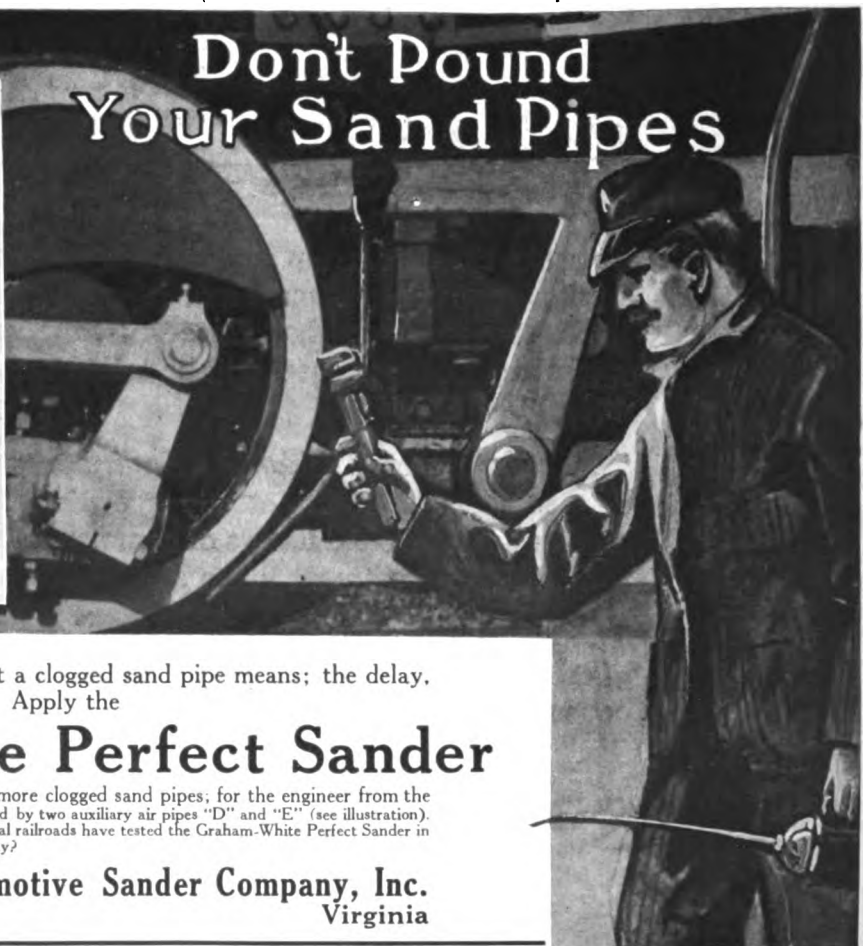

Every railway man knows what a clogged sand pipe means; the delay, the annoyance and the worry. Apply the

Graham-White Perfect Sander

to your locomotives. Its use means no more clogged sand pipes; for the engineer from the cab can clean the pipes. It's all accomplished by two auxiliary air pipes "D" and "E" (see illustration). Let us send you a complete description. Several railroads have tested the Graham-White Perfect Sander in service. May we tell you what they have to say?

White American Locomotive Sander Company, Inc.
Roanoke Virginia

We Determine Tensile

**Strength and Chemical Compositions
with Scientific Accuracy**

No matter what Testing or Laboratory problems may confront you, we can solve them to your entire satisfaction and guarantee you an unbiased analysis and report.

Our organization is entirely that of competent and experienced Engineers, Chemists and Metallurgists who are permanently employed in our departments of Tests, Physical and Chemical Laboratories.

Our Laboratories are thoroughly equipped in a most scientific manner, located at all the principal cities of the United States, and, practically, at all the principal points all over the world.

Descriptive booklets upon request.

ROBERT W. HUNT & CO.

Robert W. Hunt, Jno. J. Cone, Jas. C. Hallsted, D. W. McNaugher

Chicago: 2200 Insurance Exchange Bldg.

New York: 90 West Street.

Pittsburgh: Monongahela Bank Bldg.

St. Louis: Syndicate Trust Bldg.

London, E. C.: Norfolk House, Cannon St.

Montreal: 905 McGill Bldg.

San Francisco: 251 Kearney Street.

Toronto: Traders' Bank Bldg.

Mexico City: Avenida San Francisco No. 20.

Seattle: 322 White Bldg.

Chemical and Physical Testing

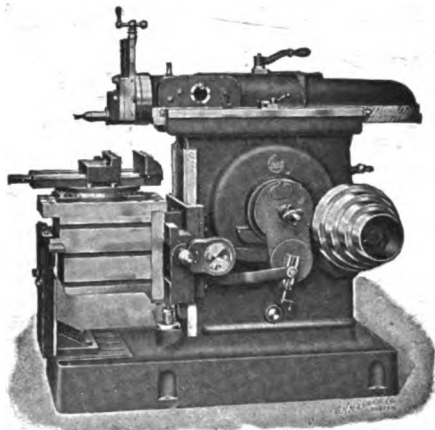

20-inch Stockbridge Shaper

With Patented Two-Piece Crank

NEW FEATURES

Base—Increased depth and rigidity.

Cross Feed—Entirely new and different from any other feed. One valuable feature is that it can be fed in either direction without change of connecting rod, or any other working part. Direction instantly changed without any change of any part of the feeding mechanism.

Stockbridge Machine Co., Worcester, Mass.

Scarritt Car Seats.

NEW METHOD REVERSIBLE.

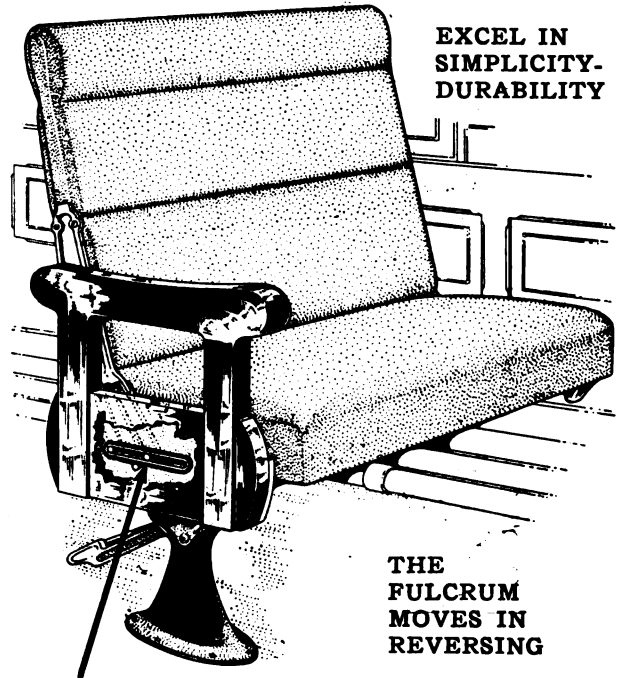

**EXCEL IN
SIMPLICITY-
DURABILITY**

**THE
FULCRUM
MOVES IN
REVERSING**

**Here Is Greatest Efficiency
In Coach Seats.**

25 YEARS IN CAR SEAT BUILDING

**THE VERY
BEST**

**RECLINING
SEATS!**

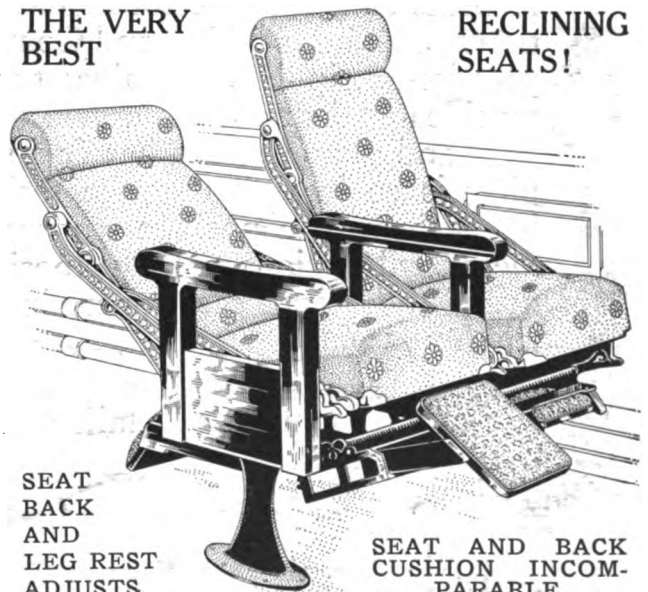

**SEAT
BACK
AND
LEG REST
ADJUSTS.**

**SEAT AND BACK
CUSHION INCOM-
PARABLE.**

**ALL METAL PARTS ARE
STEEL OR MALLEABLE IRON**

Black Curled Hair Filling Throughout

Catalog on Request

Scarritt-Comstock Furniture Corp.

Cable Address: "Scarritt-St. Louis"

Works and Offices: **ST. LOUIS, MO., U. S. A.**

Let Winter's Winds Howl and Rage

If your cars have been fitted with

UNIVERSAL Window Devices

you may be absolutely certain your passengers are riding in comfort—well protected against drafts.

The Flexible Side, Top and Bottom Weather Stripping gives a continuous bearing all around the sash, forming a seal against drafts—air—dust or moisture.

By "floating" the sash between the posts, ample play is permitted and there can be no sticking or binding of the sash due to the swelling from moist and damp weather.

A Brass Cinder Deflector in addition to the Side Rubber and Compression Strip bears against the outside metal stop while a strip of Top and Bottom Weather Stripping is so located that the sash holds them to a positive seating, these combinations making a positively tight and easy operating window.

Let us send you Full Details and tell of Installations.

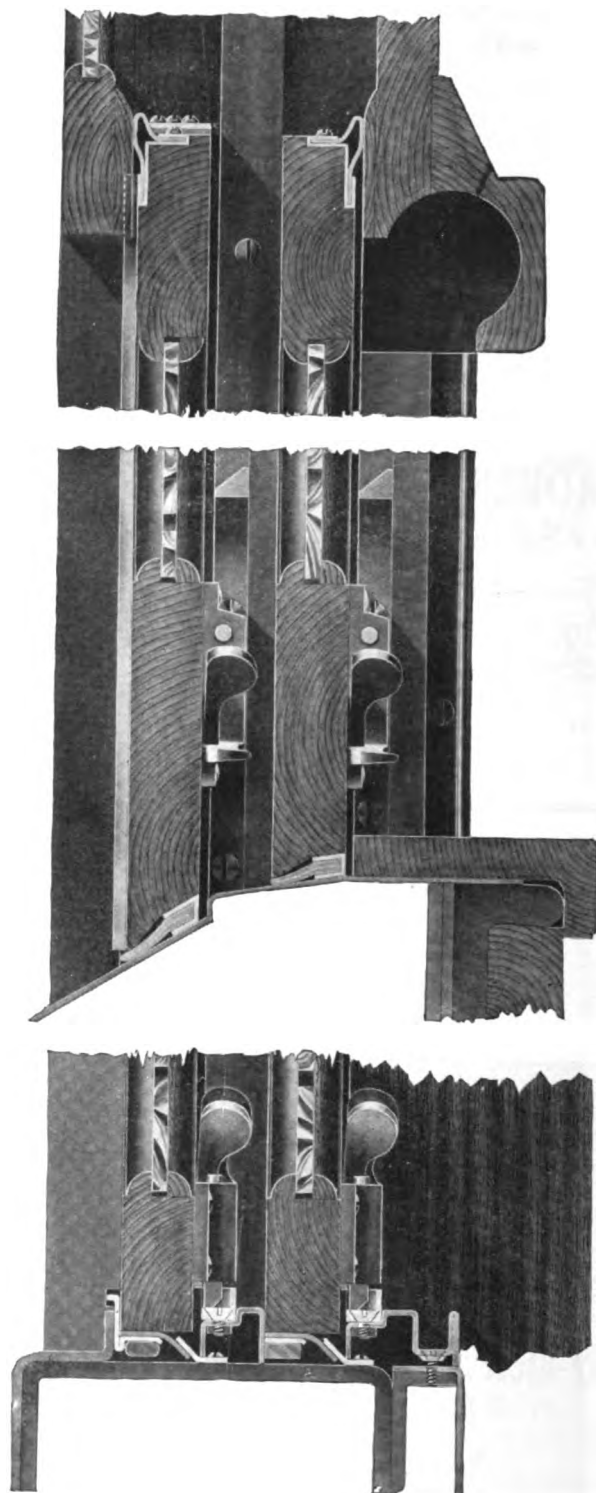

MCCORD MANUFACTURING COMPANY

UNIVERSAL Weather Stripping

" Metallic Sash
" Sash Locks
" " Balances

2587 E. GRAND BLVD.
DETROIT

PEOPLES GAS BLDG.
CHICAGO

UNIVERSAL Deck Sash Ratchets
Metal Stampings
Drawn Metal Mouldings
McKim Gaskets

50 CHURCH ST.
NEW YORK

ALPHABETICAL INDEX OF ADVERTISERS

A

Acme Machinery Co..... —
 Ajax Mfg. Co..... 18
 American Arch Co..... 30
 American Brake Shoe & Foundry Co..... 43
 American Flexible Bolt Co..... 34
 American Locomotive Co..... 29
 American Tool Works Co..... 7
 Ashton Valve Co..... 38

B

Baldwin Locomotive Works, The..... 31
 Bardons & Oliver..... 13
 Baush Machine Tool Co..... 12
 *Beaudry & Company, Inc..... —
 Bridgeford Machine Tool Works..... 24
 Bullard Machine Tool Co..... 14

C

Canton Foundry & Machine Co..... 12
 Carborundum Co. 41
 Chicago Car Heating Co..... 12
 Chicago Pneumatic Tool Co..... 40
 Cincinnati Shaper Co..... 15
 Coes Wrench Co..... 38
 Columbia Nut & Bolt Co., Inc..... 34
 Commercial Acetylene Ry. Lt. & Signal Co. 36
 Covington Machine Co..... 22

D

Dearborn Chemical Co..... 12
 Detroit Lubricator Co..... 35
 Dixon Crucible Co., Joseph..... 39

E

Electric Storage Battery Co..... 40

F

Firth-Sterling Steel Co..... 11
 Flannery Bolt Co..... 32

Foote-Burt Co., The..... 16
 Ford Chain Block & Mfg. Co..... 40

G

Galena-Signal Oil Co..... 46
 General Electric Co..... 25
 Globe Ventilator Co..... 46
 Goodyear Tire & Rubber Co..... 45
 Gould Coupler Co..... 43
 Greenfield Tap & Die Corporation..... 42

H

Hilles & Jones Co..... 38
 Hunt & Co., Robert W..... 3

I

International Oxygen Co..... 22

J

Jacobs-Shupert U. S. Firebox Co..... 36
 Jenkins Bros. 34
 Jessop & Sons, Inc., Wm..... 24

L

Landis Machine Co., Inc..... 2
 Lincoln Electric Co..... 20
 Locomotive Superheater Co..... 27
 Lucas Machine Tool Co..... 17
 Lukens Iron & Steel Co..... 32

M

McConway & Torley Co..... 43
 McCord Mfg. Co..... 4
 McNab & Harlin Mfg. Co..... 35
 Modern Tool Co..... —
 More-Jones Brass & Metal Co..... 33

N

Nathan Manufacturing Co..... 34
 National Malleable Castings Co..... 46
 Newton Machine Tool Works, Inc..... 21
 *Nicholson File Co..... 47
 Niles-Bement-Pond Co. 9

O

Oster Mfg. Co..... 38

P

Pierce Co., Wm. B..... 24
 Pilliod Co. 28
 Pratt & Whitney Co..... 9
 Prest-O-Lite Company, Inc., The..... 22

R

Railway Materials Co..... 36

S

Scarritt-Comstock Furniture Corp..... 3
 Sellers & Co., Inc., William..... 2
 Stockbridge Machine Co..... 3
 Stucki Company, A..... 46

T

Texas Co., The..... 37

U

Underwood & Co., H. B..... 22

V

Vanadium-Alloys Steel Co..... 26

W

Warner & Swasey Co..... 19
 Watertown Specialty Co..... —
 Westinghouse Air Brake Co..... 44
 Westinghouse Elec. & Mfg. Co..... 23
 White American Locomotive Sander Co... 2
 Wiley & Russell Mfg. Co..... 42

Y

Yale & Towne Mfg. Co..... 42

* Every other month.

CLASSIFIED DIRECTORY OF ADVERTISERS

Acetylene.
Commercial Acetylene Railway
Light & Signal Co.
Prest-O-Lite Co.

Acetylene Lighting.
(See Lighting, Acetylene.)

Acetylene Service.
Prest-O-Lite Company, Inc., The.

Air Brakes.
(See Brakes, Air.)

Arch, Locomotive Brick.
American Arch Co.

Arresters, Lighting.
General Electric Co.

Automatic Believing Lathes.
Niles-Bement-Pond Co.

Babbitt Metal.
More-Jones Brass & Metal Co.

Bars, Loco. Cylinder Boring.
Underwood & Co., H. B.

Batteries, Electric.
Electric Storage Battery Co.

Bearing Metal. (See Metal, Bearing.)

Bearings, Journal.
More-Jones Brass & Metal Co.

Bearings, Side.
Stucki Company, A.

Bending Machines.
Covington Machine Co.

Bending Rolls.
Covington Machine Co.

Blow Torches.
Prest-O-Lite Company, Inc., The.

Boiler Compounds.
Dearborn Chemical Co.

Boiler Shop Machinery.
Landis Machine Co., Inc.
Niles-Bement-Pond Co.
Sellers & Co., Inc., Wm.

Boiler Washers and Testers.
Nathan Mfg. Co.
Sellers & Co., Inc., Wm.

Boilers, Locomotive.
American Locomotive Co.
Baldwin Locomotive Works, The.

Bolt Cutters.
Foote-Burt Co.
Landis Machine Co., Inc.
Niles-Bement-Pond Co.

Bolt and Nut Machinery.
Ajax Manufacturing Co.
Landis Machine Co., Inc.
Niles-Bement-Pond Co.

Boring and Turning Mills.
Bullard Machine Tool Co.
Newton Machine Tool Works.
Niles-Bement-Pond Co.
Sellers & Co., Inc., Wm.
Underwood & Co., H. B.

Boring Mills, Horizontal.
Lucas Machine Tool Co.
Newton Machine Tool Works.
Niles-Bement-Pond Co.

Brake Shoes.
Amer. Brake Shoe & Foundry Co.
Railway Materials Co.

Brake Wheels.
National Malleable Castings Co.

Brakes, Air.
Westinghouse Air Brake Co.

Bronze.
More-Jones Brass & Metal Co.

Buffers, Friction.
Gould Coupler Co.

Bulldozers.
Ajax Manufacturing Co.
Canton Foundry & Machine Co.

Cables.
General Electric Co.

Car Axles.
(See Axles.)

Carborundum.
Carborundum Co.

Car Door Fasteners.
National Malleable Castings Co.

Car Door Fixtures.
Railway Utility Co.

Car Flooring.
(See Floors, Car.)

Car Heaters.
(See Heaters, Car.)

Car Lighting.
(See Lighting, Car.)

Car Roofs.
(See Floors, Car.)

Car Seats.
Scarritt-Comstock Furniture Co.

Cars, Motor.
General Electric Co.

Car-Wheel Boring Machines.
Niles-Bement-Pond Co.

Car Window Fixtures.
McCord Manufacturing Co.

Castellated Nuts.
Columbia Nut & Bolt Co., Inc.

Castings, Iron.
Covington Machine Co.

Castings, Iron and Steel.
Amer. Brake Shoe & Foundry Co.
Gould Coupler Co.
McConway & Torley Co.
National Malleable Castings Co.

Castings, Malleable Iron.
National Malleable Castings Co.

Center Plates.
National Malleable Castings Co.

Centering Machines.
Niles-Bement-Pond Co.

Chargers, Storage Battery.
Lincoln Electric Co.

Clay, Fire.
Carborundum Co.

Cold Metal Saws.
Newton Machine Tool Works.

Compressors, Air.
Chicago Pneumatic Tool Co.
General Electric Co.

Controllers.
General Electric Co.

Counterbores.
Pratt & Whitney Co.

Couplers, Car.
Gould Coupler Co.
McConway & Torley Co.
National Malleable Castings Co.

Cranes.
Niles-Bement-Pond Co.

Cranes, Portable.
Canton Foundry & Machine Co.

Cranes, Wall and Jib.
Covington Machine Co.

Crank Pin Turning Machines.
Niles-Bement-Pond Co.
Underwood & Co., H. B.

Crucibles, Steel.
Prest-O-Lite Co.

Cutter Grinders.
Niles-Bement-Pond Co.

Cutting (Oxy-Acetylene).
Prest-O-Lite Company, Inc., The.

Cylinders, Hydrogen and Oxygen.
International Oxygen Co.

Dies.
Landis Machine Co., Inc.
Pratt & Whitney Co.

Drilling Machines.
American Tool Works Co.
Foote-Burt Co.
Niles-Bement-Pond Co.
Pratt & Whitney Co.
Sellers & Co., Inc., Wm.

Drilling Machines (Arch Bar).
Foote-Burt Co.
Niles-Bement-Pond Co.

Drilling Machines, Horizontal.
Foote-Burt Co.

Drilling Machines, Multiple.
Baush Machine Tool Co.
Foote-Burt Co.
Niles-Bement-Pond Co.
Pratt & Whitney Co.

Drilling Machines, Radial.
American Tool Works Co.
Baush Machine Tool Co.
Niles-Bement-Pond Co.

Drills.
Foote-Burt Co.
Pratt & Whitney Co.

Drills, Portable (Electric).
Chicago Pneumatic Tool Co.

Drills, Portable (Pneumatic).
Chicago Pneumatic Tool Co.

Dynamos and Motors.
General Electric Co.

Electric Lighting and Power.
General Electric Co.
Westinghouse Electric & Mfg. Co.

Engineers.
Hunt & Co., Robert W.

Engine Frames. (See Frames, Engine.)

Engines, Crude and Fuel Oil.
Chicago Pneumatic Tool Co.

Engines, Gas and Gasoline.
Chicago Pneumatic Tool Co.

Exhaust Fans and Heads.
General Electric Co.

Expanders, Flue.
Chicago Pneumatic Tool Co.
Pratt & Whitney Co.

Fans, Electric.
General Electric Co.
Westinghouse Electric & Mfg. Co.

File Cleaner.
Nicholson File Co.

Files.
Nicholson File Co.

Files, Tool Making.
Nicholson File Co.

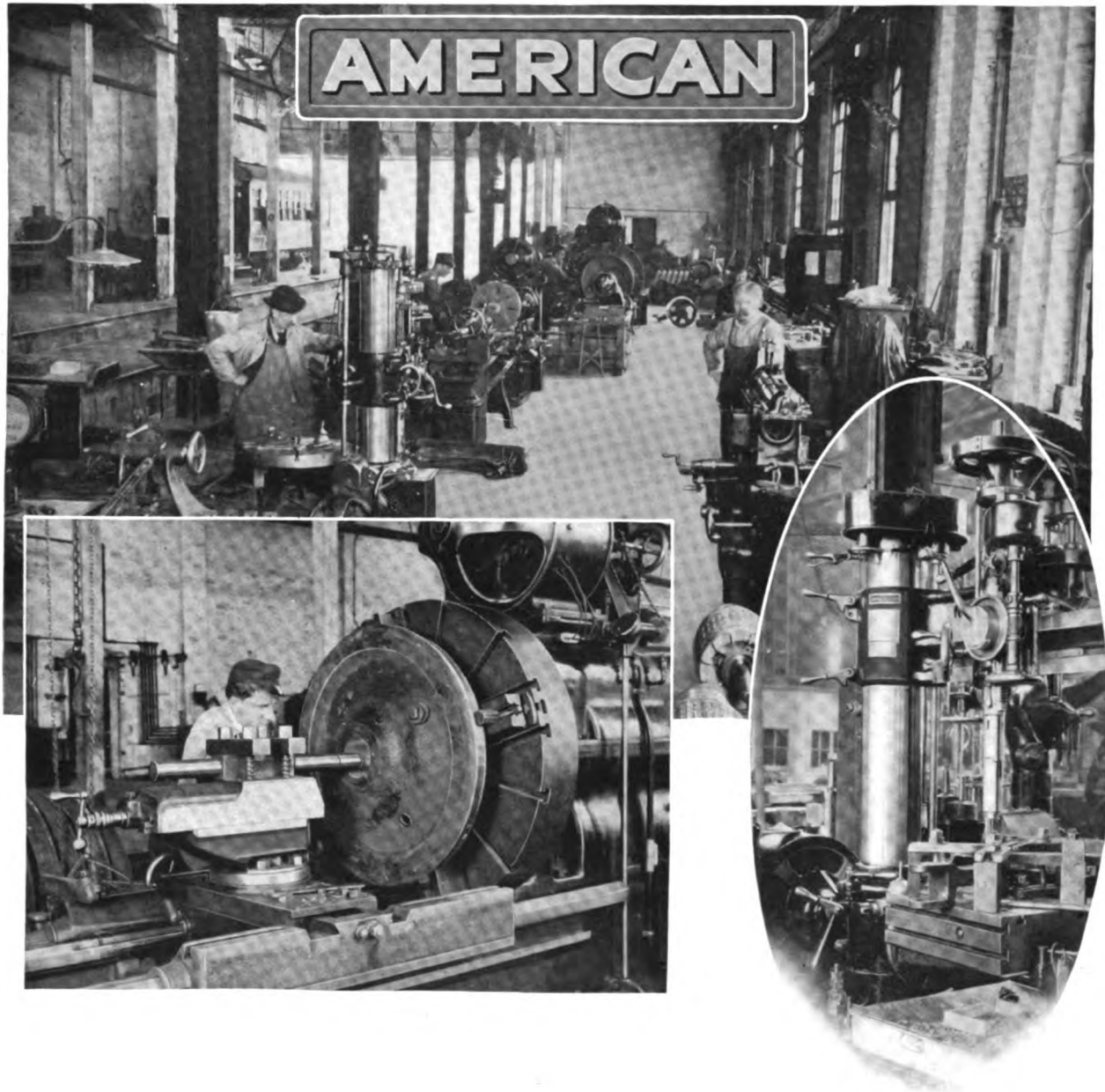

A TYPICAL "AMERICAN" R. R. SHOP

Wherein everything runs smoothly and the work produced is beyond criticism. In this shop "American" Lathes, Shapers and Radial Drills are each doing their individual share toward bringing about the ultimate result which spells success and advancement for the road.

THE AMERICAN TOOL WORKS CO.

CINCINNATI, U. S. A.

LATHES — PLANERS

SHAPERS — RADIALS

CLASSIFIED DIRECTORY OF ADVERTISERS—(Continued)

Fire Boxes. Jacobs-Shupert U. S. Firebox Co.	Holsts, Electric. Chicago Pneumatic Tool Co. Niles-Bement-Pond Co.	Lighting, Acetylene. Prest-O-Lite Co.	Mouldings, Drawn Metal. McCord Manufacturing Co.
Flanging Clamps. Covington Machine Co.	Holsts, Pneumatic (Geared). Chicago Pneumatic Tool Co.	Lighting, Car. Commercial Acetylene Railway Light & Signal Co. General Electric Co. Gould Coupler Co.	Multiple Drills. Niles-Bement-Pond Co. Pratt & Whitney Co.
Flanging Machines. Hilles & Jones Co.	Holsts, Portable. Canton Foundry & Machine Co. Ford Chain, Block & Mfg. Co. Yale & Towne Mfg. Co.	Lock Nuts. Columbia Nut & Bolt Co., Inc.	Nipple Threading Machines. Landis Machine Co., Inc.
Flanging Presses. Niles-Bement-Pond Co.	Hose, Air, Steam, Etc. Chicago Pneumatic Tool Co. Goodyear Tire & Rubber Co.	Locomotives. American Locomotive Co. Baldwin Locomotive Works, The	Nut Locks. Columbia Nut & Bolt Co., Inc.
Flue Cutters. Chicago Pneumatic Tool Co. Underwood & Co., H. B.	Hose, Air Brake. Goodyear Tire & Rubber Co. Westinghouse Air Brake Co.	Locomotive Boilers. (See Boilers, Locomotive.)	Oils. Galena-Signal Oil Co.
Flue Expanders. (See Expanders, Flue.)	Hose Protectors. McCord Manufacturing Co.	Locomotive Brick Arch. (See Arch, Locomotive Brick.)	Oil Cups. Detroit Lubricator Co. Nathan Mfg. Co.
Forges. Chicago Pneumatic Tool Co.	Hydraulic Presses and Pumps. (See Presses, Hydraulic; Pumps, Hydraulic.)	Locomotive Sanders. (See Sanders, Locomotive.)	Oil Stones. Carborundum Company.
Forging Machines. Ajax Manufacturing Co.	Hydrogen. International Oxygen Co.	Locomotives, Compressed Air. Baldwin Locomotive Works, The	Oxy-Acetylene Apparatus. International Oxygen Co.
Furnaces. Railway Materials Co.	Injectors. Nathan Mfg. Co. Sellers & Co., Inc., Wm.	Locomotives, Electric. American Locomotive Co. Baldwin Locomotive Works, The General Electric Co. Westinghouse Electric & Mfg. Co.	Oxy-Hydrogen. International Oxygen Co.
Gap Lathes. Bridgeford Machine Tool Works. Niles-Bement-Pond Co.	Insulating Materials. General Electric Co.	Locomotives, Mine. Baldwin Locomotive Works, The General Electric Co.	Oxygen. International Oxygen Co.
Gages. Pratt & Whitney Co. Ashton Valve Co.	Journal Boxes and Lids. Gould Coupler Co. National Malleable Castings Co.	Locomotive Valve Gear. (See Valve Gear, Locomotive.)	Packing. Jenkins Bros.
Gages, Pressure and Vacuum. Ashton Valve Co.	Lamps, Flare. Prest-O-Lite Company, Inc., The	Lubricants. Dixon Crucible Co.	Pedestal Facers. Underwood & Co., H. B.
Gages, Water. Nathan Mfg. Co.	Lamps, Gas. Commercial Acetylene Railway Light & Signal Co. Prest-O-Lite Co.	Lubricators. Detroit Lubricator Co. Nathan Mfg. Co.	Pipe Benders. Underwood & Co., H. B.
Gages, Wheel Press Recording. Ashton Valve Co.	Lamps, Incandescent. General Electric Co. Westinghouse Electric & Mfg. Co.	Lubricators, Force Feed. McCord Mfg. Co.	Pipe Threading Machinery. Oster Mfg. Co.
Gaskets. McCord Manufacturing Co.	Lathes. American Tool Works Co. Bardons & Oliver Bridgeford Machine Tool Works. Bullard Machine Tool Co. Niles-Bement-Pond Co. Pratt & Whitney Co. Sellers & Co., Inc., Wm. Warner & Swasey Co.	Machine Tools. Ajax Manufacturing Co. American Tool Works Co. Bardons & Oliver Baush Machine Tool Co. Bridgeford Machine Tool Works. Bullard Machine Tool Co. Cincinnati Shaper Co. Foot-Burt Co. Hilles & Jones Co. Landis Machine Co., Inc. Lucas Machine Tool Co. Newton Machine Tool Works. Niles-Bement-Pond Co. Pratt & Whitney Co. Sellers & Co., Inc., Wm. Stockbridge Machine Co. Underwood & Co., H. B. Warner & Swasey Co.	Pipe Threading and Cutting-Off Machinery. Landis Machine Co., Inc. Niles-Bement-Pond Co.
Generating Sets. General Electric Co.	Lathes, Axle. Bridgeford Machine Tool Works.	Metal Stampings. McCord Manufacturing Co.	Planers. Newton Machine Tool Works. Niles-Bement-Pond Co. Sellers & Co., Inc., Wm.
Generators, Electric. Lincoln Electric Co.	Lathes, Brass Workers. Niles-Bement-Pond Co.	Milling Cutters. Pratt & Whitney Co.	Planers, Plate. Covington Machine Co.
Generators, Hydrogen and Oxygen. International Oxygen Co.	Lathes, Driving Wheel. Niles-Bement-Pond Co.	Milling Machines. Newton Machine Tool Works. Niles-Bement-Pond Co. Pratt & Whitney Co. Underwood & Co., H. B.	Planers, Valve Seat. Underwood & Co., H. B.
Grinding Machines. Niles-Bement-Pond Co. Pratt & Whitney Co.	Lathes, Engine (Heavy). Bridgeford Machine Tool Works.	Motors, Electric. General Electric Co. Lincoln Electric Co. Westinghouse Electric & Mfg. Co.	Planing Attachments, Radius. Underwood & Co., H. B.
Grinders, Portable (Electric). Chicago Pneumatic Tool Co.	Lathes, Geared Head. Bridgeford Machine Tool Works. Niles-Bement-Pond Co.		Planing Machines. American Tool Works Co. Niles-Bement-Pond Co. Underwood & Co., H. B.
Grinders, Portable (Pneumatic). Chicago Pneumatic Tool Co.	Lathes, Journal Truing. Bridgeford Machine Tool Works.		Plates, Boiler, Firebox, etc. Lukens Iron & Steel Co.
Grinding Wheels. Carborundum Company.	Lathes, Turret. Bardons & Oliver Niles-Bement-Pond Co. Pratt & Whitney Co. Sellers & Co., Inc., Wm. Warner & Swasey Co.		Pneumatic Tools. [See Tools, Pneumatic.]
Hammers, Board and Steam Drop. Niles-Bement-Pond Co.			Pointing Machines, Bolt. Landis Machine Co., Inc.
Hammers, Pneumatic. Sellers & Co., Inc., Wm.			Portable Tools. (See Tools, Portable.)
Hammers, Power. Beaudry & Co., Inc.			Presses, Hydraulic (Arbor, Axle, Bending, Broaching, Car Wheel, Flanging, Forging, Forming, Straightening, Wheel). Niles-Bement-Pond Co.
Hammers, Steam. Beaudry & Co., Inc.			Presses, Power, Forcing. Lucas Machine Tool Co.
Hammers, Trip. Beaudry & Co., Inc.			
Handles, File. Nicholson File Co.			
Headlights. Commercial Acetylene Railway Light & Signal Co. General Electric Co.			
Heaters, Car. Chicago Car Heating Co.			
Holsts, Chain. Canton Fdy. & Mach. Co. Ford Chain Block & Mfg. Co. Yale & Towne Mfg. Co.			

The Car Wheel Borer for Repair Shops and Car Builders

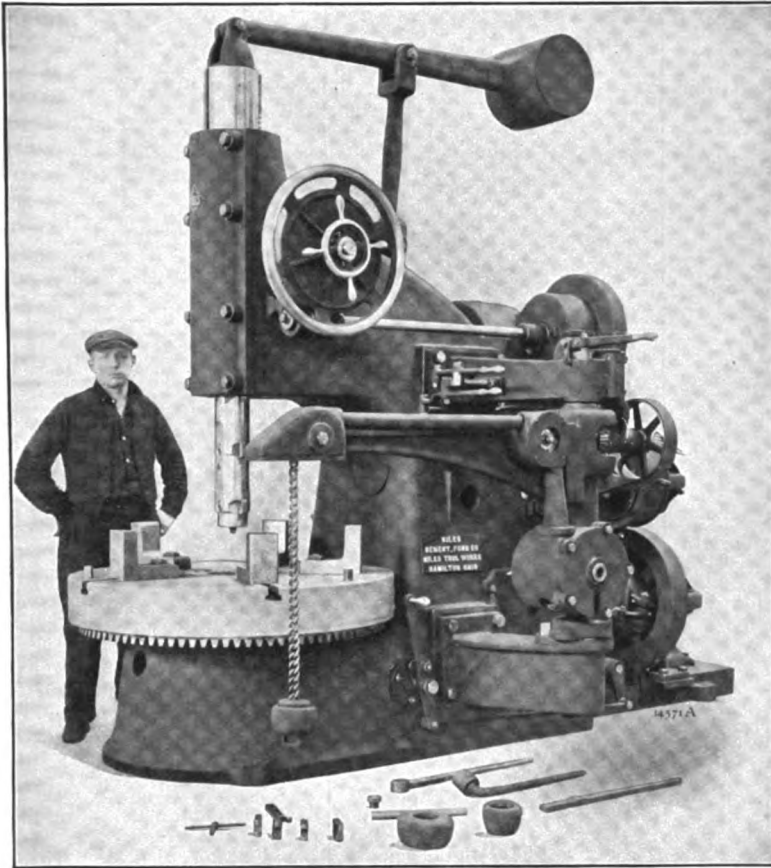

48 inch 1915 Design Car Wheel Borer

Can Use Long Bars

Machine has ample height from table to underside of frame and sufficient bar movement to use the long bars shown above. The roughing and finishing tools of these bars are so arranged that the roughing tool goes through the wheel hub before the finishing tool enters.

Hub Facing Attachment

will be furnished if ordered. The bar feeds from center to outside of wheel and can be operated at same time as main boring bar is feeding down. Hand-wheels for the control of hub facer bar are located on operator's side of machine.

New 4 Page Circular No. 101 with full description and illustrations of hub facing attachment, crane in operation and various arrangements of drive.

Niles-Bement-Pond Co.,

111 Broadway, New York City
25 Victoria St., London, S. W.

SALES OFFICES AND AGENCIES—Boston: 93-95 Oliver St. Philadelphia: 405 N. 21st St. Pittsburgh: Frick Bldg. Cleveland, O.: The Niles Tool Works Co., Rockefeller Bldg. Hamilton, O.: The Niles Tool Works Co. Cincinnati: 336 W. 4th St. Detroit: Kerr Machinery Bldg. Chicago: The McCormick Bldg. St. Louis: 516 North Third St. Birmingham, Ala.: 2015 First Ave. San Francisco: 16 to 18 Fremont St. For Colorado, Utah, Wyoming and New Mexico: Hendrie & Bolthoff Mfg. & Supply Co., Denver. For Seattle: Hallidie Machinery Co. For Canada: The John Bertram & Sons Co., Ltd., Dundas, Montreal, Winnipeg, Vancouver. Japan: The F. W. Horne Co., 6 Takiyama-cho, Kyobashi-ku, Tokio. Italy: Ing. Ercole Vaghi, Milan. France: Glaenger & Perreaud, 18 Faubourg du Temple, Paris. Germany: F. G. Kretschmer & Co., Frankfurt, a.M. Austria-Hungary: E. Krause & Co., Vienna, Prague and Budapest. Holland: R. S. Stokvis & Zonen, Ltd., Rotterdam. For Mexico: The Railway Supply Co., S. A. Cinco de Mayo, 6, Mexico City. Russia: S. G. Martin & Co., Ltd., Petrograd and Moscow. Brazil: Comptoir Technique Bresellen, P. O. Box 802, Rio de Janeiro.

Equipped for Steel and Cast Iron Wheels

THIS machine has recently been re-designed and placed on the market to meet the needs of railroad repair shops and car builders. The control is arranged so that the machine is easily and conveniently operated. There is the required weight and power and the proper range of speeds and feeds for steel as well as cast iron wheels.

Wheel Clamped in Chuck by Single Motion

The chuck has capacity for wheels up to 42 in. in diameter on tread. Table is fitted with a self-centering, universal chuck operated by a single motion of a cam lever that gives sufficient movement for firmly gripping the wheel. On the table there are three shafts squared to receive a wrench for tightening the chuck; one is always sure to be within easy reach of operator.

Drum or Pneumatic Crane

For handling wheels to and from table, machine is equipped with either a drum type crane, as shown above, or a pneumatic crane if preferred. Either type is convenient and rapid in operation. Cranes are made with a long reach.

CLASSIFIED DIRECTORY OF ADVERTISERS—(Continued)

Punches.
Covington Machine Co.
Niles-Bement-Pond Co.
Sellers & Co., Inc., Wm.

Punching and Shearing Machines.
Covington Machine Co.
Hilles & Jones Co.
Niles-Bement-Pond Co.
Pratt & Letchworth Co.

Rasps.
Nicholson File Co.

Reamers.
Chicago Pneumatic Tool Co.
Pratt & Whitney Co.

Reamers, Adjustable.
Pratt & Whitney Co.

Regrinding Valves.
Ajax Manufacturing Co.
McNab & Harlin.

Riveting Machines.
Chicago Pneumatic Tool Co.

Rolls, Reclaiming.
Ajax Manufacturing Co.

Sanders, Locomotive.
White Am. Locomotive Sander Co.

Sash Balances.
McCord Manufacturing Co.

Sash Locks.
McCord Manufacturing Co.

Sash, Metal.
McCord Manufacturing Co.

Screw Machines.
Warner & Swasey Co.

Sensitive Drill Presses.
Niles-Bement-Pond Co.

Shapers.
American Tool Works Co.
Cincinnati Shaper Co.
Niles-Bement-Pond Co.
Pratt & Whitney Co.
Sellers & Co., Inc., Wm.
Stockbridge Machine Co.

Shapes, Pressed Steel.
Prest-O-Lite Co.

Shapes, Vertical.
Pratt & Whitney Co.

Shears.
Covington Machine Co.
Niles-Bement-Pond Co.

Shears, Alligator.
Canton Foundry & Machine Co.
Covington Machine Co.

Signal Lighting, Acetylene.
Commercial Acetylene Railway Light & Signal Co.
Prest-O-Lite Co.

Slotting Machines.
Newton Machine Tool Works.
Niles-Bement-Pond Co.

Sockets—Drill and Reamer.
Pratt & Whitney Co.

Spacing Tables.
Covington Machine Co.

Staybolt and Bolt Turning Machines.
Baush Machine Tool Co.
Landis Machine Co., Inc.

Staybolts.
American Flexible Bolt Co.
Flannery Bolt Co.

Staybolt Taps.
Pratt & Whitney Co.
Wiley & Russell Mfg. Co.

Steel, Locomotive Firebox.
Lukens Iron & Steel Co.

Steel, Tool.
Firth-Sterling Steel Co.
Jessop & Sons, Inc., Wm.
Vanadium-Alloys Steel Co.

Stocks and Dies.
Pratt & Whitney Co.
Wiley & Russell Mfg. Co.

Storage Batteries. (See Batteries, Electric.)

Superheaters.
Locomotive Superheater Co.

Tanks.
Prest-O-Lite Co.

Taps.
Pratt & Whitney Co.
Wiley & Russell Mfg. Co.

Testing Apparatus, Oxygen.
International Oxygen Co.

Tie Plates.
National Malleable Castings Co.

Tire Turning and Boring Mills.
Niles-Bement-Pond Co.

Tool Steel [See Steel, Tool.]
Firth-Sterling Steel Co.

Tools, Boltermakers.
Chicago Pneumatic Tool Co.

Tools, Pneumatic.
Chicago Pneumatic Tool Co.

Tools for Railway Repair Shops.

Tools, Portable.
Underwood & Co., H. B.

Tools, Threading.
Oster Mfg. Co.

Trucks.
McConway & Torley Co.

Trucks, Electric.
American Locomotive Co.
Baldwin Locomotive Works, The

Turntables, Industrial Shop.
Canton Foundry & Machine Co.

Upsetting Machines.
Ajax Manufacturing Co.

Valve Gear, Locomotive.
Pilliod Co.

Valves.
Jenkins Bros.

Valves, Cylinder Stud, Oxygen and Hydrogen.
International Oxygen Co.

Valves, Muffler Safety.
Ashton Valve Co.
Nathan Mfg. Co.

Valves, Open Safety.
Ashton Valve Co.
Nathan Mfg. Co.

Valves—Pop, Safety, Throttle and Blow-Off.
Ashton Valve Co.
Detroit Lubricator Co.
Nathan Mfg. Co.

Ventilators, Car.
Globe Ventilator Co.

Ventilators.
Globe Ventilator Co.

Ventilating Fans.
General Electric Co.

Washers, Lock.
National Malleable Castings Co.

Water Purifiers.
Dearborn Chemical Company

Weather Strips.
McCord Manufacturing Company

Welders, Electric Arc.
Lincoln Electric Co.

Welding (Oxy-Acetylene).
Commercial Acetylene Railway Light & Signal Co.
Prest-O-Lite Company, Inc., The

Welding and Cutting Apparatus.
International Oxygen Co.
Lincoln Electric Co.
Prest-O-Lite Co.

Welding Apparatus (Electric Arc).
Westinghouse Electric & Mfg. Co.

Welding Supplies.
Prest-O-Lite Company, Inc., The

Welding Tools.
International Oxygen Co.

Whistles.
Ashton Valve Co.
General Electric Co.
Nathan Mfg. Co.

Window Fixtures.
McCord Manufacturing Co.

Wrecking Hooks.
National Malleable Castings Co.

Wrenches.
Coes Wrench Co.

BLUE  CHIP

AND OTHER

Firth-Sterling Tool Steels

THE knowledge, experience and skill of Sheffield combined with the best Pittsburgh practice have made these steels the standards of Quality and Uniformity wherever Tools are used.

FIRTH-STERLING STEEL COMPANY

McKEESPORT, PA.

BOSTON NEW YORK PHILADELPHIA CHICAGO
CLEVELAND PITTSBURGH DETROIT SAN FRANCISCO

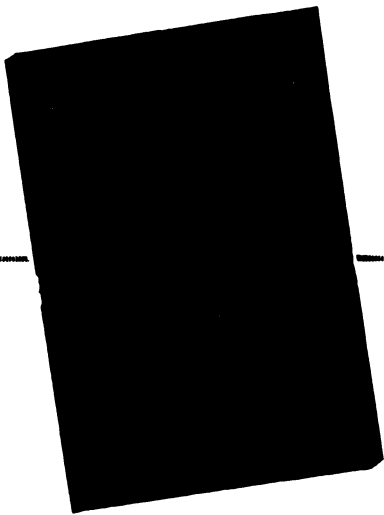

Send For This Booklet

"Some Ill Effects of Boiler Feed Waters
And Their Causes"

Last year, Mr. W. A. Converse, Directing Chemist of our Company, delivered a lecture before the Railway Club of Pittsburgh, Pa., which was received with such interest that we have thought it might be of value to Motive Power Officials generally, and we've had several hundred copies printed, many of which have already been distributed in response to requests.

Dearborn Service

If you are having trouble with bad water supplies on your railroad, you will find us ready to give you every assistance in the preliminary work for beginning the use of Dearborn Treatment. May we send you the booklet?

DEARBORN CHEMICAL COMPANY McCormick Building
CHICAGO, ILL.

**Lassiter Staybolt Threading
and Reducing Machine**

Built with
Four, Six and Eight Spindles

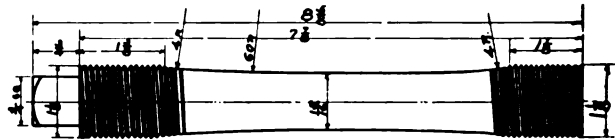

25 to 35 PER SPINDLE—PER HOUR

Automatic reduction of center made while threading without additional expense.

Send for pamphlet.

Bausch Machine Tool Company
Springfield, Mass.

NEW YORK OFFICE:
50 Church Street

CHICAGO OFFICE:
McCormick Building

Drilling Machinery

Consisting of Radial Drills, Multiple Drills, Special Multiple Drilling Machines.

Also Lassiter Straight and Taper Bolt Turning Machines. Staybolt Drilling Machines.

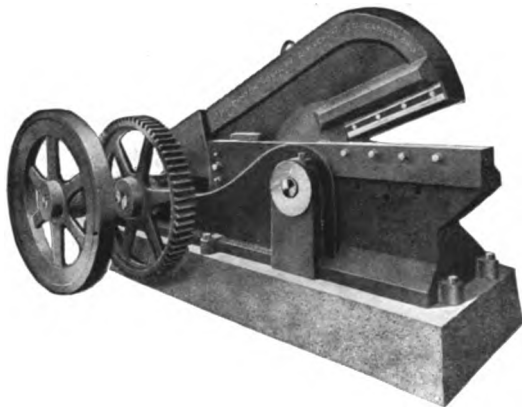

**Cut Your Reclaiming
Costs In Two**

Put the Canton Alligator Shears to work at the scrap pile. Its powerful jaws will "bite" through iron and soft steel up to 4" square—depending on size—at one clip. In short

Canton Alligator Shears

will cut your reclaiming costs in two. Besides, it costs far less to operate than expensive gas flame cutters.

Every railway man ought to investigate the merits of these shears; he ought to investigate his present costs for reclaiming scrap. Our Catalog D-17 sent on request.

CANTON FOUNDRY & MACHINE CO.
CANTON OHIO
Manufacturers of
Industrial Turntables, Portable
Floor Cranes and Hoists

VAPOR SYSTEM

OF

CAR HEATING

Direct Steam Heat without any pressure on the radiating pipes. Pressure retained in drain pipe. Considerably less drain on the locomotive.

CHICAGO CAR HEATING CO.

CHICAGO: RAILWAY EXCHANGE BLDG.
NEW YORK: GRAND CENTRAL TERMINAL BLDG.
WASHINGTON, D. C.: 229 MUNSEY BLDG.
MONTREAL, QUE.: 61 DALHOUSIE STREET.
ATLANTA, GA.: CANDLEP. BLDG.

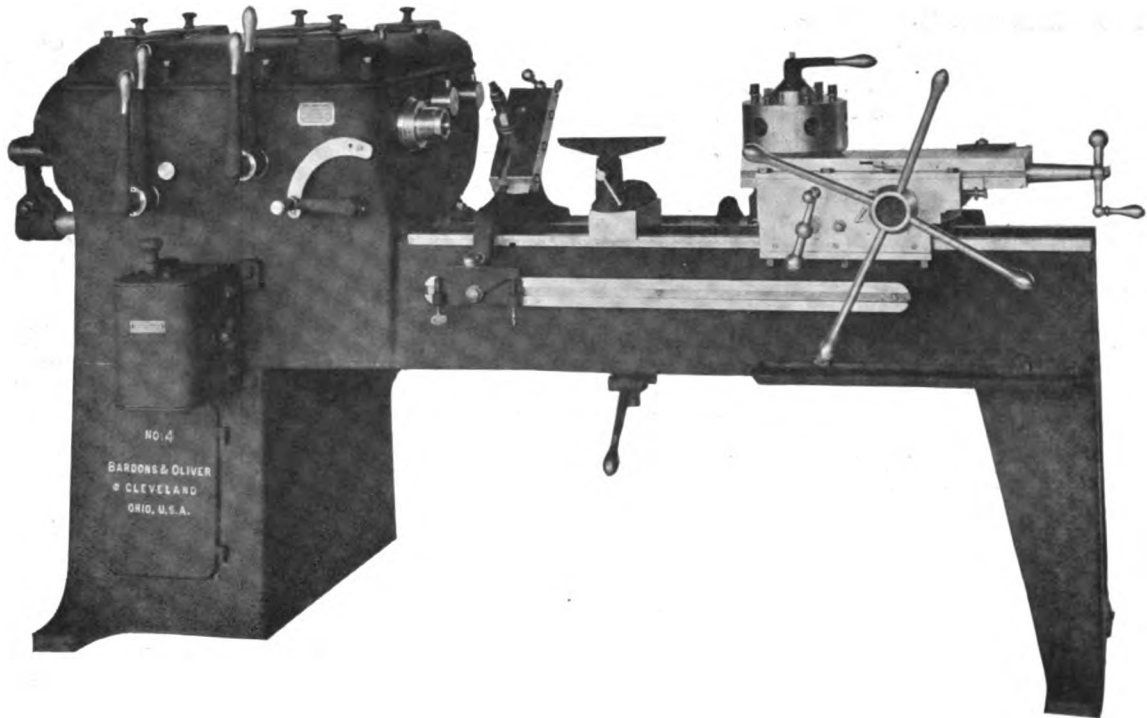

BARDONS & OLIVER

Direct Connected Motor Driven "Fox" Lathe

The increased efficiency in the use of direct motor-driven tools is universally acknowledged. They allow complete and easy operation of overhead cranes and maximum flexibility in shop arrangement. The B. & O. Motor-Driven Universal Turret Lathe shown above, for a number of reasons, is the ideal lathe for the railroad shop. It is distinctive for the ease and freedom with which it is operated, and for its wide range and the speed with which short-run jobs can be handled.

Constant Speed Motor, D. C. or A. C.

Selective speed; all-g geared head; eight spindle speeds, from 33 to 558 R.P.M.; all changes of speed and reverse obtained by friction clutches operated while machine is running. In addition to this the back gears can be thrown out, if desired, when the machine is being used for any length of time on the higher speeds.

Also Furnished with Single Pulley Drive

instead of Motor, to fill requirements of shops where electrical current is not available, which construction permits machine to be run direct from line shaft without the use of counter-shaft.

Taper Chasing Attachment adjusts along a T-slot located on front of bed. Adapted for both external and internal threading; right and left hand, straight or taper threads can be cut with the same leader and follower. Follower arm made in two parts with a spring between that keeps the follower in full contact with the leader when cutting taper threads.

Send for Folder "R" and Detail Specifications

Bardons & Oliver

CLEVELAND, OHIO

What Do You Mean By "Efficient?"

When you say a machine tool is efficient what do you mean? Do you mean it is easy to operate?

Centralized Control puts all movements of the Vertical Turret Lathe within the operator's reach; he need not step from a two-foot circle. Power traverse enables him to operate head and slide without any physical strain.

Do you mean it is rapid?

The fundamental principle of the Vertical Turret Lathe is the elimination of wasted time. It not only operates without wasted time, but it gets multiplied value out of productive time whenever possible by Multi-Cutting.

Do you mean it enables you to get full value from your labor?

The Vertical Turret Lathe conserves the operator's energy. Work done on it is done without waste of energy at a rate held continuously, rapidly and evenly throughout the day.

The Vertical Turret Lathe is up to Your Standard of Efficiency

The true meaning of efficiency is the greatest return per dollar invested. It is up to this standard that the Vertical Turret Lathe measures.

You buy it because it will save you money on your face plate work.

And the sooner you buy it the more money you will save.

Let us put the facts and figures before you.

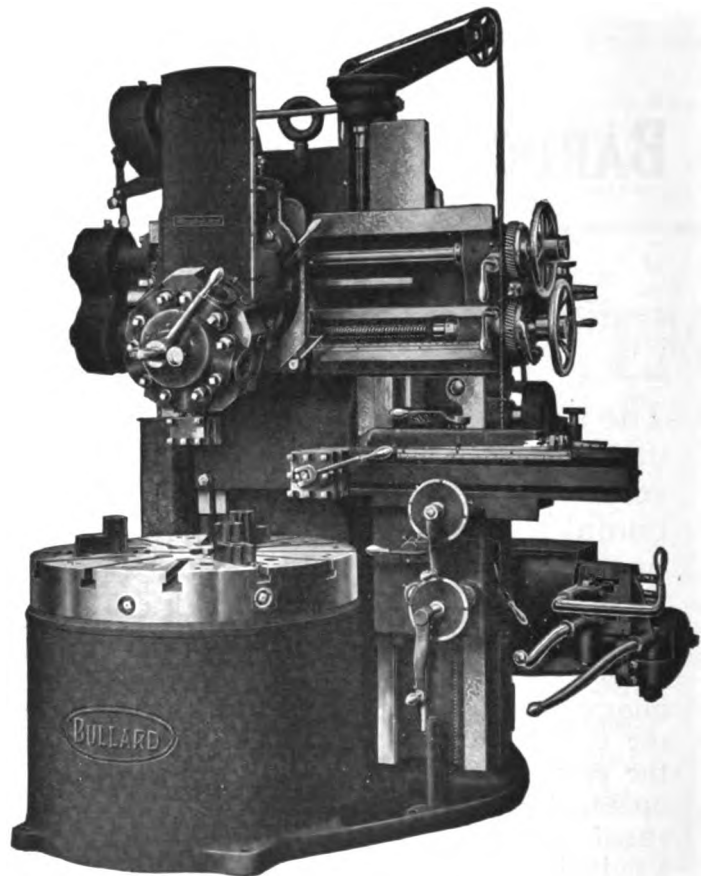

The Bullard Machine Tool Co.

Bridgeport, Conn., U. S. A.

AGENTS: Williams & Wilson, Montreal. A. R. Williams Mach. Co., Toronto, Winnipeg, Vancouver. Fenwick Freres & Co., Paris, France. Heinrich Dreyer, Berlin, Germany. Landre & Glinderman, Amsterdam, Holland. Alfred Herbert, Coventry, Eng. Axel Ryden, Stockholm.

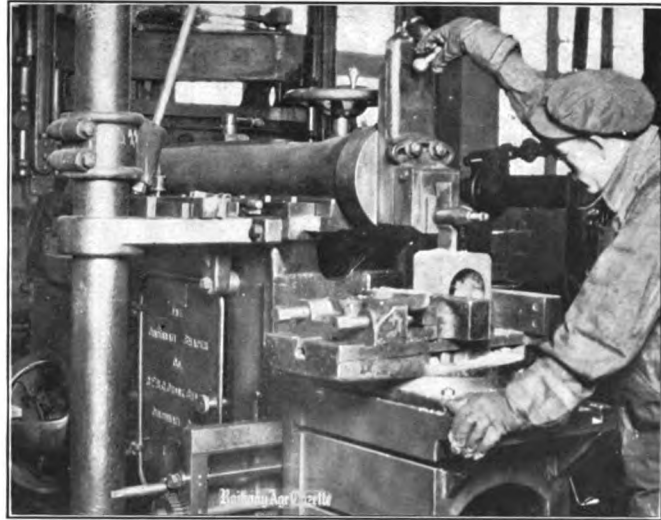

This Shaper Can Handle Many of Your Slotter Jobs

There are a surprisingly large number of jobs in any railroad shop that can be handled on a shaper more quickly and economically than on any other kind of machine. This is especially true if the shaper is a

Cincinnati 32" Railroad and Mfg. Shaper

For instance, on machining inside of driving boxes; the length of stroke in connection with a circular feeding head (hand or power) and the concave attachment enables this machine to handle such slotter jobs at a lower cost.

The gear ratio with the size of cone pulley makes the "Cincinnati" more powerful than any other shaper of equal stroke. Every part has been designed consistent with its power—insuring the necessary strength and rigidity to withstand any stresses.

The several special attachments that can be furnished with the "Cincinnati" make it a very versatile machine that is highly adapted for handling a very wide range of work.

Let us send you our bulletin describing this *ideal* shaper for railroad shops.

THE CINCINNATI SHAPER COMPANY

Cincinnati, Ohio.

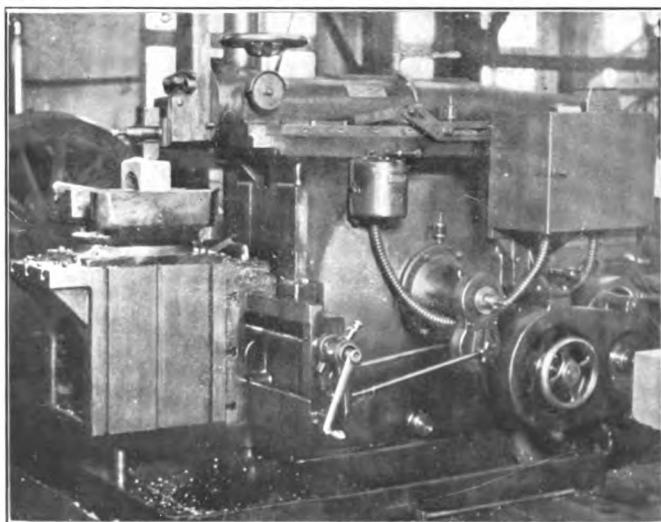

Cut The Cost Of Drill Work

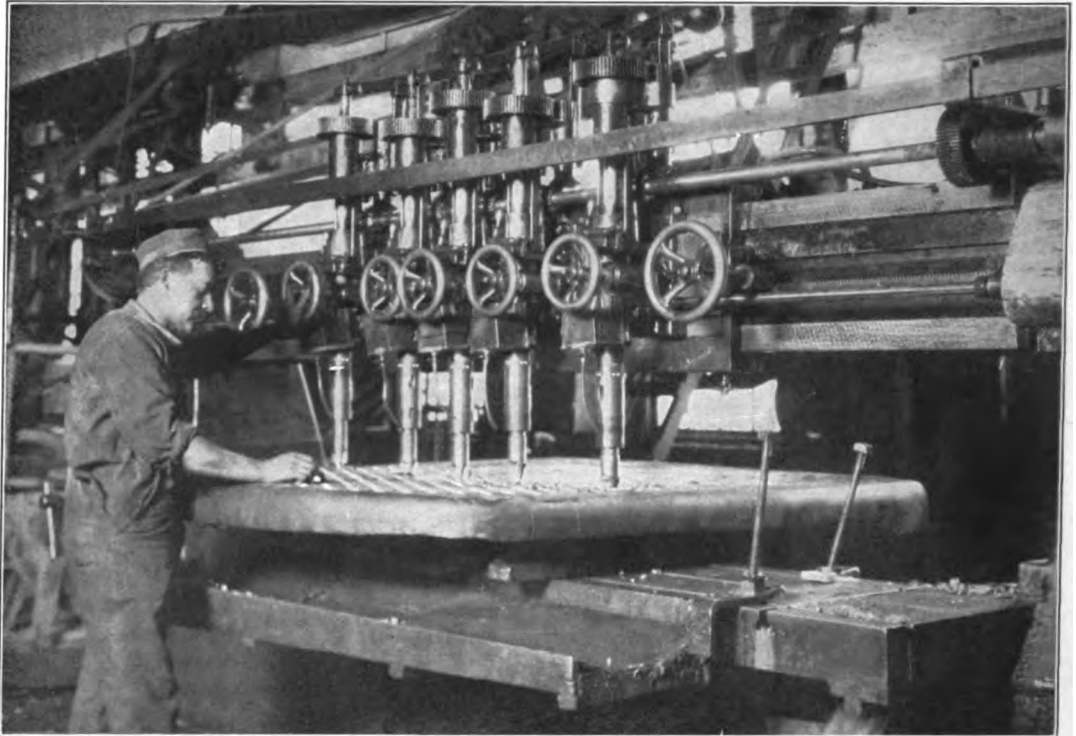

The Foote-Burt Flue Sheet and Mud Ring Drill

280 2" holes drilled thru 1-2" firebox steel in less than 2 hours—averaging a hole about every 25 sec. That's what the No. 2 Foote-Burt Flue Sheet and Mud Ring Drill shown in the picture was doing when the photograph was taken in the Milwaukee Shops of the C. M. & St. P. R. R. The drill shown is arranged with five No. 2 Heads mounted on auxiliary crossrails; the drilling is being done with five spindles. After the work is set up on the table only one operator is required to finish the job. The independent feed feature of the machine, its variety of feeds and speeds and the ease and facility with which table adjustments are made, have made this drill a general favorite on the class of work for which it is designed. Folder No. 2 gives some interesting information. Let us send it to you.

THREE TYPES OF SPINDLE HEADS can be applied to this machine, adapting it to a large variety of work. The heads are arranged with independent geared power feed, provided with adjustable stop. Clutch for stopping and starting spindle is controlled by a single lever conveniently located. Spindles are forged of high-carbon steel, with ball bearing thrust guaranteed not to crush under the most severe duty. **THE CROSS RAIL** is heavy and well ribbed with wide face and large bearing surface. **THE HOUSINGS** are of heavy box section, well ribbed and are well bolted to base and rail. **THE TABLE** has large working surface and has planed T-slots. It has an in and out adjustment of 36 inches, which is obtained by racks and pinions and crank wrench at each end of machine. **MUD-RING CHUCKS** are furnished, which are equipped with two screws for holding the mud-ring in place. When machine is used on flue sheet drilling these chucks are taken off. **THE BASE** is of continuous box form and thoroughly ribbed, making the machine a self-contained unit, not dependent on its foundation for rigidity. It is arranged so a pit can be provided to come up to the front edge of same to take care of mud-rings. It is also furnished with bracket slides to support the table out under the spindles when drilling flue sheets. **EXTRA ATTACHMENTS:** Oil pump, piping and tank. Motor drive.

The Foote-Burt Company, CLEVELAND OHIO.

LUCAS "Precision"

Boring, Drilling and Milling Machine

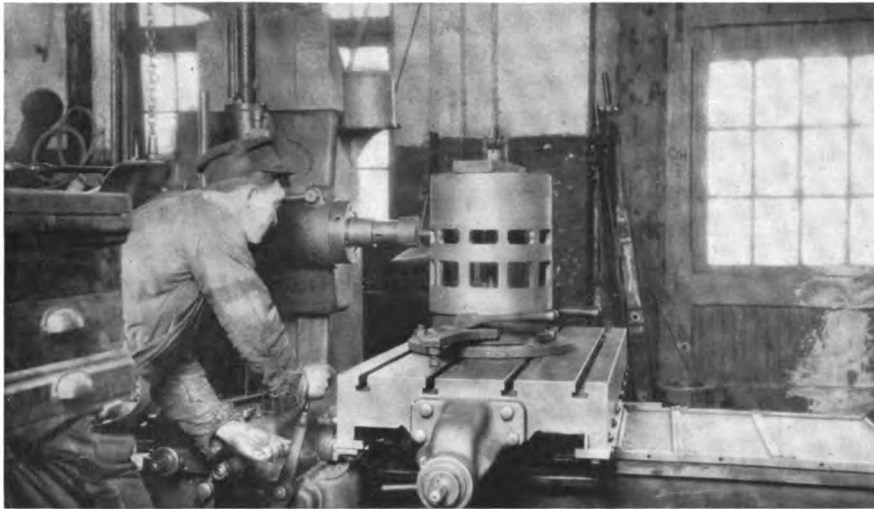

**Cuts
The
Time
By
Saving
Set-Ups**

Milling Ports of Valve Bushing with a great saving of time over former methods and without expensive special tools or fixtures

THE quick and easy handling of the feeds and quick power movements are great factors in the saving of time on a job like this. A large amount of work in railroad shops, requiring several kinds of machining operations, which usually require to be carried from one machine to another, can be finished on the Lucas "Precision" Boring, Drilling and Milling Machine with one setting and without the use of jigs, and with greater accuracy, because all the cuts are automatically true to each other.

"Saving Set-Ups In Railroad Shops"

A compilation of valuable data collected in the shops of various large railroad systems of the country. Copiously illustrated with photographs showing improved methods and practices being used in efficient shops. It should be in the hands of every mechanical official, shop superintendent and foreman. A copy will be sent upon request.

Send For It Today

RAILWAY MEN using the Lucas "Precision" Boring, Drilling and Milling Machine, claim that it is one of the handiest, most versatile time- and labor-saving tools in their shops. Let us tell you some things they have to say about it and give you a production estimate on some of your difficult jobs.

LUCAS MACHINE TOOL CO.

CLEVELAND, OHIO

"Always In Repair"

Since 1903

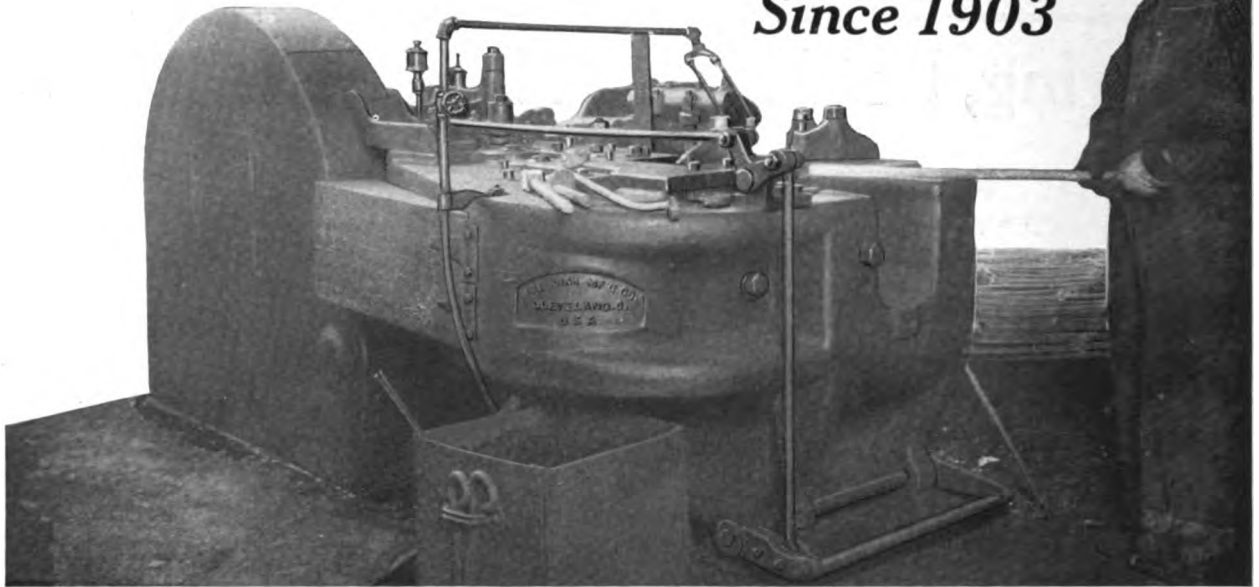

THINK over the twelve year record of this machine in the Havelock shops of the C. B. & Q. It has been doing every kind of forging work from spring hangers to this Gooseneck Socket Wrench and as the foreman says: "The Ajax is always in repair. I like the simplicity of the operating mechanism."

AJAX FORGING MACHINES

Simplicity and strength of construction are the features which the railroad man has always appreciated in Ajax Machines.

The machines require little attention or repairs. Operators spend their time in actual productive work and not in tinkering. The range of work is so great that an Ajax Machine is seldom idle, yet depreciation is lower than that of any other piece of equipment in the shop.

Ajax engineers are practical forge shop men. Their advice is freely at the disposal of railway shop men.

**The Ajax
Manufacturing Co.**
CLEVELAND, OHIO

1369 Hudson Terminal
New York City

621 Marquette Bldg.
Chicago, Ill.



Dies and Headers for making Gooseneck Socket Wrench for turning caps on Tate Stay-bolts. Made from 1½ inch round one operation in upper and one in lower groove. Cost about 5 cents.

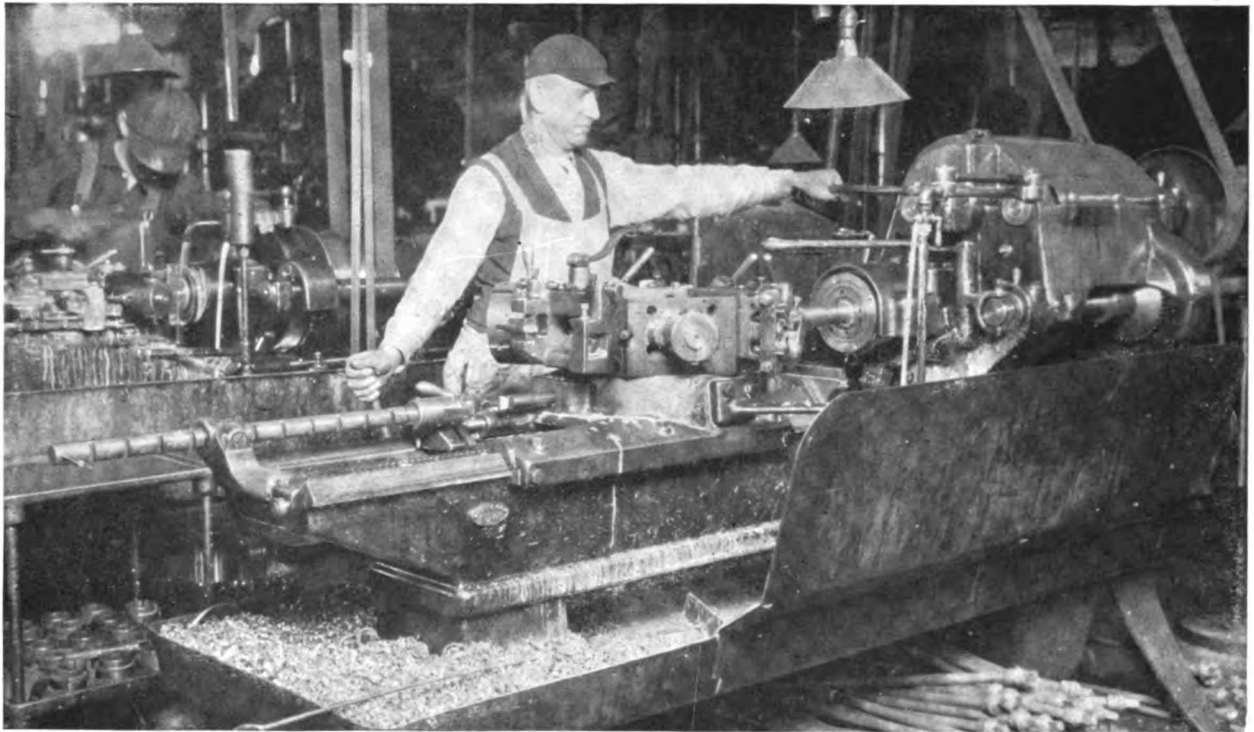

High Efficiency on Short Runs

The above view, taken in a railroad shop, shows driver brake pins being turned out in five minutes each—twelve an hour. And this is only one of some thirty jobs, in the same shop, on which production time has been greatly reduced by using the

Universal Hollow-Hexagon Turret Lathe

This machine, made in two sizes, is notable for its high efficiency on short runs, producing small quantities on an economical manufacturing basis.

Ask us to show the time that could be saved on your everyday work. Send blueprints with rough and finished samples.



High Efficiency—Because of the separate feed shafts for carriage and turret saddle, each with ten individual feeds, you can face or form or undercut with the square turret while you bore or turn with the hexagon turret.

Quick Operation—You can work as many as eleven tools with one set-up. There is more than enough power to drive the work to the limit, taking the deepest cut or highest speed your cutting tools will stand. And the power rapid traverse runs back the turret saddle at the rate of 35 feet a minute.

Quick Preparation—Tooling is set up and stops adjusted so quickly that this machine is economical on the short runs that used to be done only on an engine lathe.

Accurate Duplication—Set the adjustable stops as you turn out the first piece, and each succeeding piece will be an accurate duplicate within the closest possible limits.

THE WARNER & SWASEY COMPANY, CLEVELAND OHIO

New York Office: Singer Building
Boston Office: Oliver Building

Buffalo Office: Iroquois Building
Detroit Office: Ford Building

Chicago Office and Showrooms: 618-622 Washington Boulevard

Not Only a Question of Saving But *How Much* Saving

Railway men no longer doubt the saving made by welding in their maintenance and repair departments. It has been proven by the experience of too many roads.

The big question now is, "Are we saving as much as we can?"

To every railway shop man who asks this question we make this statement of fact:

Lincoln Arc Welders

will do your welding work at a fraction of the cost by any other method. This we are willing to prove in your own shop on your own particular welding problems.

The reasons for this are: First, that the electric arc will give a higher temperature than any other practical method of producing heat for welding purposes. Second, the Lincoln Arc Welder will produce the electric arc with less consumption of current per unit of work than any other apparatus.

Welding requires a voltage of from 10 to 50 volts. The Lincoln Welder gives at all times the exact voltage required. Think of the saving compared with a 75 volt constant voltage machine where resistances must always be used to "cut down" that 75 volts and waste 30 to 80 per cent. of the power.

There are other points about the Lincoln Welder that the railway man should consider. It is simple to operate and hence low in labor cost. The installation can be started small and varied to absolutely meet the needs of the work in hand. It *always* costs just in proportion to the service it renders.

We know these are strong statements, but we're itching to prove 'em. Ask us.

THE LINCOLN ELECTRIC CO.

Manufacturers of Electrical Machinery

CLEVELAND, OHIO.

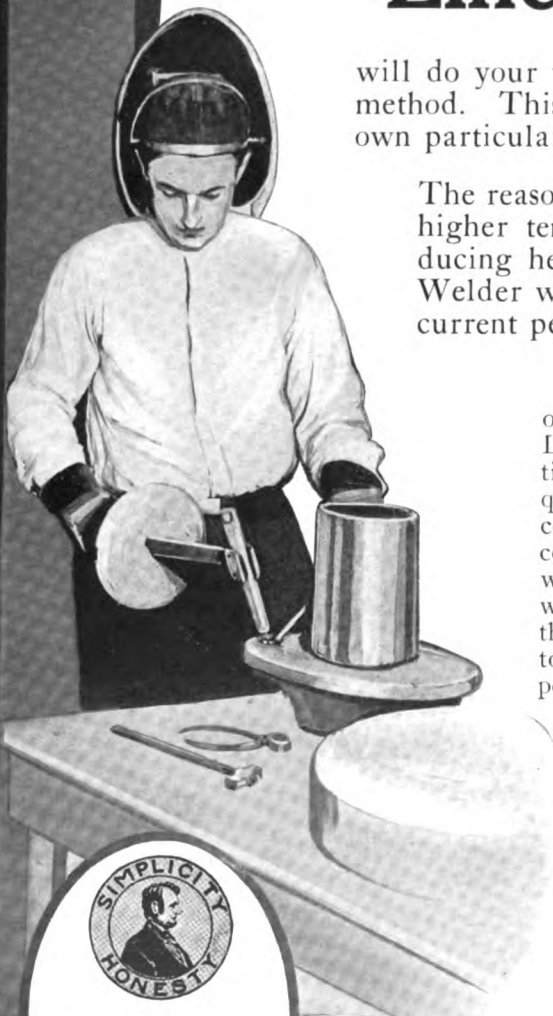

Bulletin
No. 50
FREE.

NEWTON

(Registered Trade Mark)

A PRONOUNCED SUCCESS

**One in Stock
for
immediate
Shipment.**

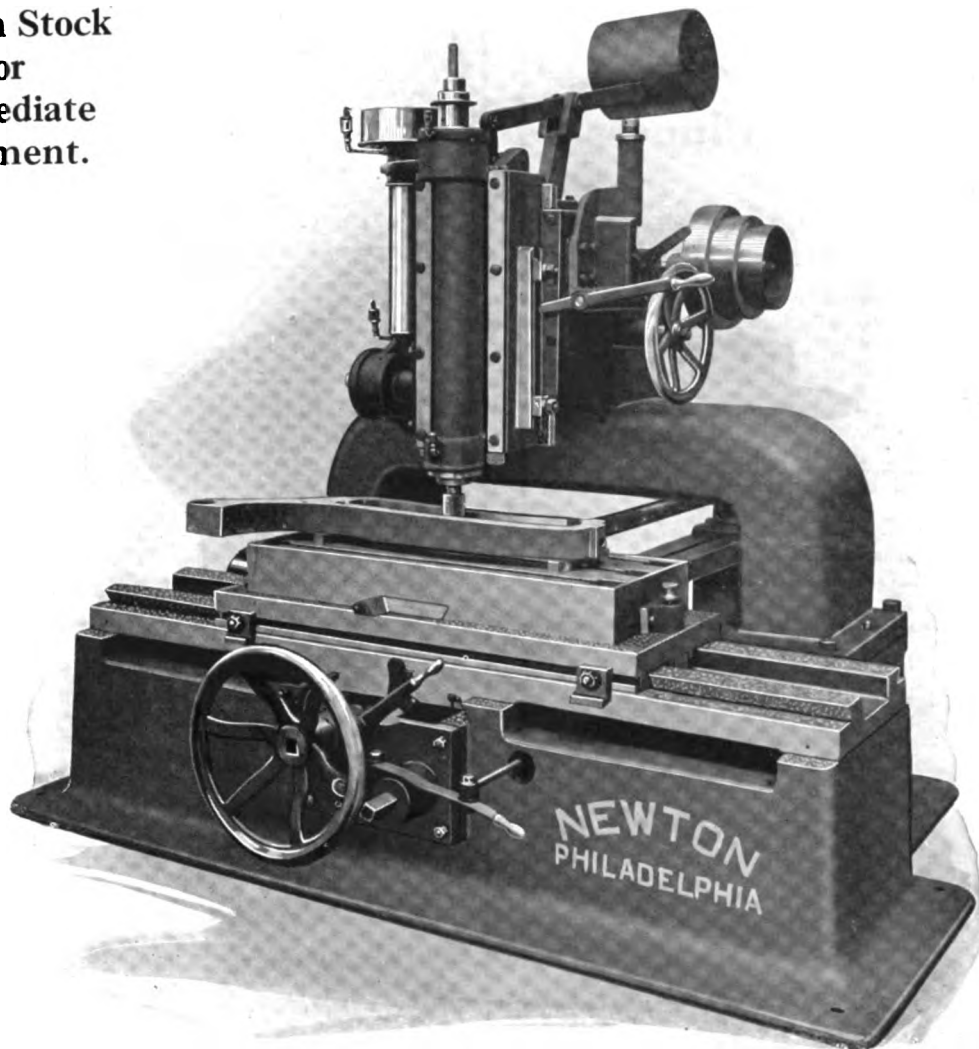

LOCOMOTIVE LINK GRINDING MACHINE

Maximum capacity 100-inch radius on 5-inch face links, Automatic except adjustment for depth of cut.

Reciprocating spindle motion is available for use when clearance permits of large diameter emery wheels, and where lack of clearance interferes, a continuous feed is used, and, like the radius milling machine, adjustment for depth of cut and from side to side is possible without disturbing the radius control.

Cold Metal Sawing Machines
Duplex Rod Boring Machines
Locomotive Rod Milling Machines

Cylinder Boring Machines
Slotting Machines
Crank Planers

NEWTON MACHINE TOOL WORKS, Incorporated

23rd and Vine Streets

Philadelphia, U. S. A.

Portable Boring Bar for Cylinder and General Work

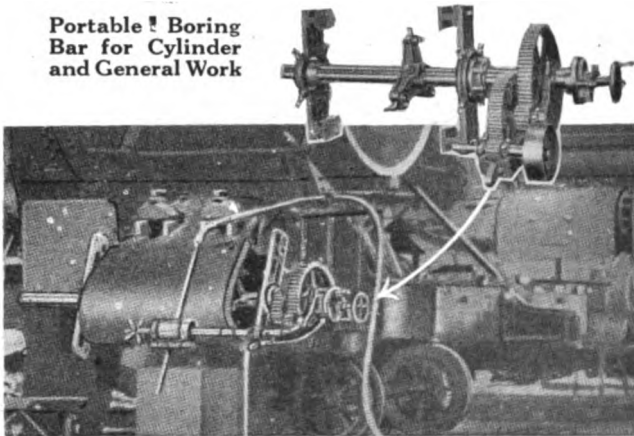

Rebore Your Cylinders In Position

Save time and money by reboring cylinders without removing them from the bed. Don't break steam joints, bolts, etc., when the work can be done at once with our

Portable Boring Bar

Made especially for locomotive cylinders. Its length is convenient and arranged for the usual diameters. It will bore with one or both cylinder heads off; and in any position; so constructed that the piece being bored serves as a support for the bar.

We are prepared to build any size of bars to meet requirements of purchasers. For complete description and table of driving speeds, address us.

H. B. UNDERWOOD & CO.

1025 HAMILTON STREET PHILADELPHIA, PA.
The Home of Portable Tools for Railway Repair and Machine Shops
Established 1870



I. O. C. System installation General Electric Co., Pittsfield, Mass. This is one of five plants we erected for the General Electric Co.

Make your own OXYGEN with the I. O. C. Generators and save 60%

of what you are paying for gas in cylinders. This remarkable economy is being demonstrated daily in such representative industrial plants as the following:

- Aluminum Company of America (in two plants).
- Cooper Hewitt Electric Co., Hoboken, N. J.
- Edison Storage Battery Co., Orange, N. J.
- General Electric Co., (in five plants).
- Lever Bros. Ltd., Toronto, Canada.
- Middvale Steel Co., Philadelphia, Pa.
- Pittsburgh Steel Foundry Co., Glassport, Pa.
- Swift & Co., Chicago, Ill.
- Taylor-Wharton Iron & Steel Co., Highbridge, N. J.
- U. S. Navy Yard, Brooklyn, N. Y.
- Westinghouse Lamp Co., Bloomfield, N. J.

We shall be glad to send descriptive pamphlet and figure on your Oxygen and Hydrogen requirements.

International Oxygen Company, General Sales Office: 115 Broadway, New York
Works: Newark, N. J.

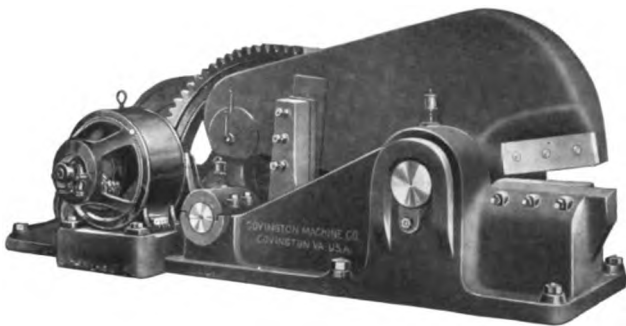

Covington Alligator Shears

Are built for hard, rough usage — which such a tool usually gets.

Write Us Your Requirements

Builders of Punches, Shears, Bending Rolls, Bending Clamps, Plate Planers, Etc.

Write for Bulletin No. 11 showing our complete line.

COVINGTON MACHINE COMPANY

86 Wall St., New York

Works: Covington, Va.

Prest-O-Lite

PROCESS

Oxy-Acetylene Welding and Cutting

is a reduction to the simplest and most efficient form of this money saving method that has a real place in every railroad shop.

Necessary equipment is not expensive. We furnish thoroughly high-grade apparatus for \$60; acetylene service at slight additional cost. Adaptable for oxy-acetylene metal cutting by addition of special cutting apparatus.

Backed by Universal Permanent Service

Every user of oxy-acetylene apparatus can enjoy added efficiency, convenience and simplicity by using Prest-O-Lite Acetylene Service. Furnishes the highest grade of Dissolved Acetylene (ready-made carbide gas) in portable cylinders. Used as conveniently as cylinders of oxygen. Saves large initial outlay and heavy depreciation of making crude acetylene in carbide generators. Perfectly dried, cleaned and purified—makes better welds and is cheaper to use.

Send for illustrated literature and full details of the Prest-O-Lite Service Plan.

The Prest-O-Lite Company, Inc.

The World's Largest Makers of Dissolved Acetylene.

806 Speedway, Indianapolis
53 Branches and Charging Plants

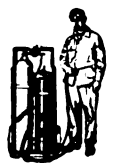

One Railroad Man Writes to Another

on Westinghouse Electric Arc Welding Equipment

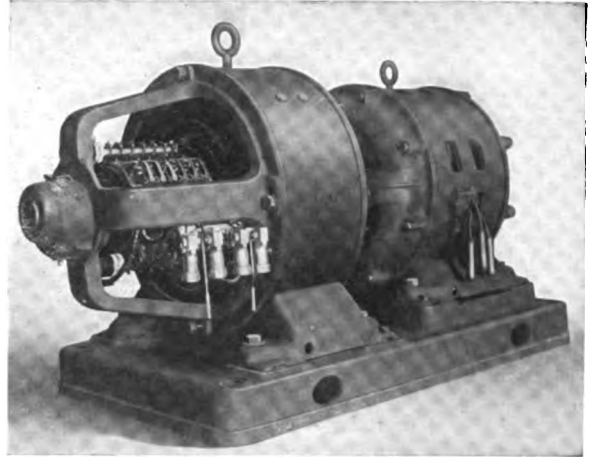

ARC-WELDING MOTOR-GENERATOR SET. CAN BE SUPPLIED FOR OPERATION ON ANY COMMERCIAL POWER CIRCUIT.

"I am very pleased to state that this equipment has given entire satisfaction and absolutely no trouble and that we are performing all classes of welding work, including that directly overhead and flue welding. In connection with the latter class of work we are meeting with particularly good success We have four operators regularly at work each day and there have been no cases where the work of one operator in any way interfered with the others." (Name of road on request.)

This extract from a letter written by a user of

Westinghouse Electric Arc Welding Equipment

to a friend considering the installation of a similar equipment (whose road has since purchased two outfits) states very positively the successful operation to be expected with our apparatus. And this is not an unusual case. All our users are equally enthusiastic.

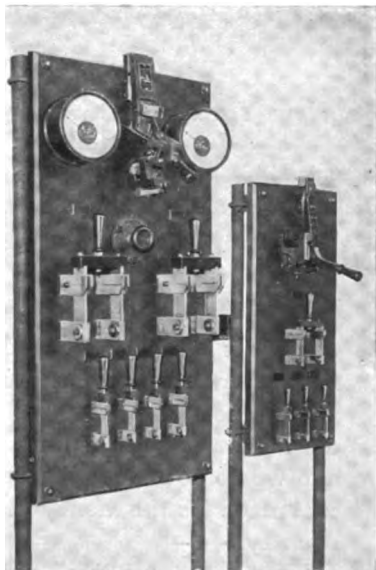

ARC WELDING GENERATOR CONTROL PANEL AND OPERATOR'S PANEL.

You can get as good results as this road has with a Westinghouse arc welding equipment in your shop. Twenty-one large railroad systems have standardized on this equipment. Let us tell you why.

Send for our booklet "*Electric Arc Welding Processes.*"

Westinghouse Electric & Mfg. Co.

Sales Offices in All
Large American Cities



East Pittsburgh,
Pennsylvania

Say Welding—Think Westinghouse

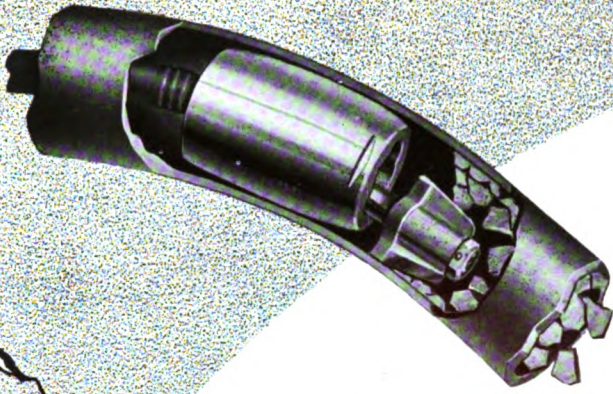

How Do YOU Clean Your Arch Tubes?

By boring—scraping—chopping away the scale from the tubes? Think of the labor and time this method takes—and do you *actually* free the tubes *entirely* from scale? Why not free your tubes from scale scientifically—*entirely* eliminating scale incrustation by using the



Arch Tube Cleaner

Operating by either steam or air it transmits a continuous stream of sharp, quick taps—6,000 taps per minute—against the tube wall. This local vibration loosens the scale "root and all" from the tube wall and the exhaust expels it.

Barrel shape, and its operating principle, insures the positive removal of scale from the bends.

Write for our free book, "Scale Removal Made Easy." It is a complete analysis of the scale problem. "The Cleaning of Locomotive Arch Tubes" discusses your particular problem.

Note—Our free trial offer and guaranteed result plan will interest every shop superintendent, master mechanic and shop foreman. Ask us about it.

THE WM. B. PIERCE CO.

39 No. Division Street, Buffalo, N. Y.



Jessop's Best Carbon Steel and "Ark" High Speed Steel

FOR DIES AND HIGH GRADE TOOLS

Always Uniform

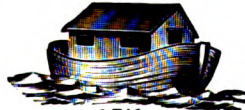

Most Economical

Jessop's "Ark" High Speed Steel

Has Stood the test. Has many imitators but no equal
Manufactured in Sheffield, England

TOOL STEEL FORGINGS

Wm. Jessop & Sons, Inc., 91 John Street, New York City

Boston Warehouse, 163 High Street

St. Louis Warehouse, 714 No. 2nd Street

Warehouses throughout the U. S.

BRIDGEFORD AXLE LATHES

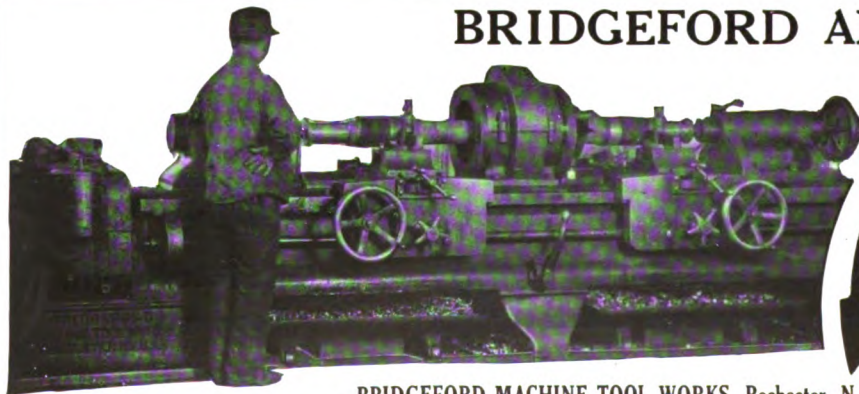

Read What This User Says

" - - - it has cost us nothing for repairs to this date. It is a very powerful machine and does the work quickly and well and we do not know of a better tool made for the money in this country. - - - "

(Name on request.)

Write for our catalog that gives you the reasons "WHY."

BRIDGEFORD MACHINE TOOL WORKS, Rochester, N. Y.
Heavy Engine Lathes Heavy Axle Lathes

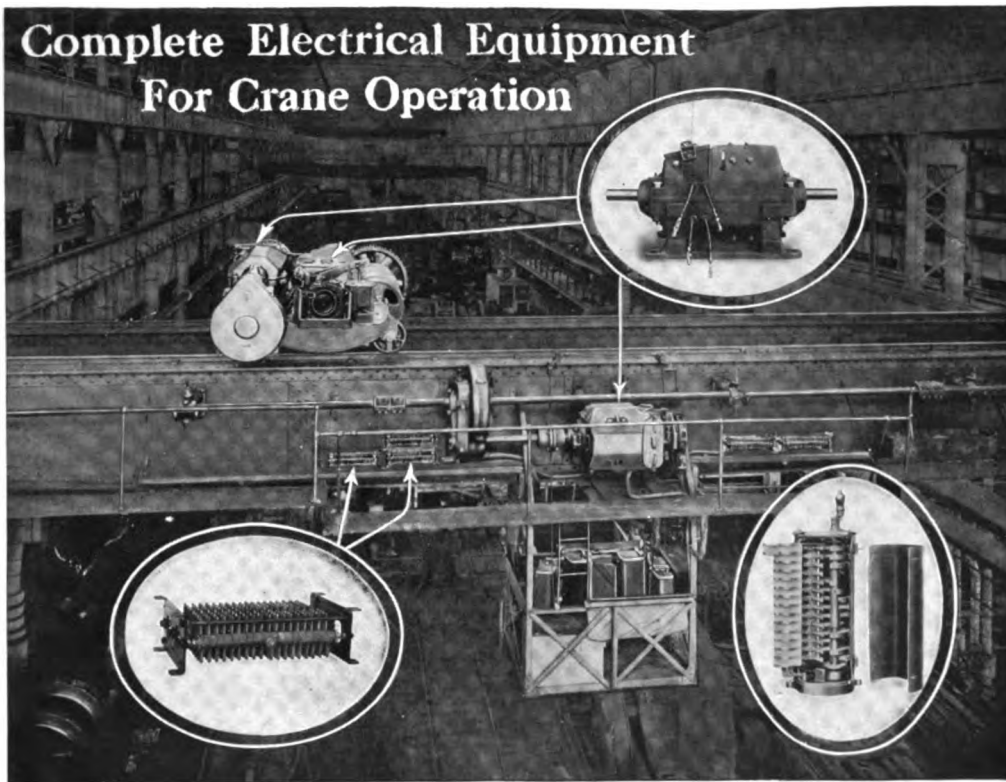

This trade-mark the guarantee of excellence on Goods Electrical

ADDRESS NEAREST OFFICE

- Atlanta, Ga.
- Baltimore Md.
- Birmingham, Ala.
- Boston, Mass.
- Buffalo, N. Y.
- Butte, Mont.
- Charleston, W. Va.
- Charlotte, N. C.
- Chattanooga, Tenn.
- Chicago, Ill.
- Cincinnati, Ohio
- Cleveland, Ohio
- Columbus, Ohio
- Dayton, Ohio
- Denver, Colo.
- Des Moines, Iowa
- Duluth, Minn.
- Elmira, N. Y.
- Erie, Pa.
- Fort Wayne, Ind.
- Hartford, Conn.
- Indianapolis, Ind.
- Jacksonville, Fla.
- Joplin, Mo.
- Kansas City, Mo.
- Knoxville, Tenn.
- Los Angeles, Cal.
- Louisville, Ky.
- Memphis, Tenn.
- Milwaukee, Wis.
- Minneapolis, Minn.
- Nashville, Tenn.
- New Haven, Conn.
- New Orleans, La.
- New York, N. Y.
- Niagara Falls, N. Y.
- Omaha, Neb.
- Philadelphia, Pa.
- Pittsburgh, Pa.
- Portland, Ore.
- Providence, R. I.
- Richmond, Va.
- Rochester, N. Y.
- St. Louis, Mo.
- Salt Lake City, Utah
- San Francisco, Cal.
- Schenectady, N. Y.
- Seattle, Wash.
- Spokane, Wash.
- Springfield, Mass.
- Syracuse, N. Y.
- Toledo, Ohio
- Washington, D. C.
- Youngstown, Ohio

G-E engineers have studied crane requirements and designed electrical apparatus to meet known operating conditions. Every requirement for stopping or starting and the entire operating cycle is fully met by specially designed apparatus.

Motors

Interpole motors, capable of standing heavy overloads are manufactured in any speed or horse power needed. These motors have split frames and large handholes for accessibility and can be disassembled without disturbing back gearing.

Brakes

G-E crane motors are furnished with automatic solenoid brakes which work without jar or shock and make automatic compensation for brake shoe wear. Brake shoes made of metallized asbestos compound give a high coefficient of friction with but little wear.

Rheostats and Protective Panels

The cast iron grid rheostats used for crane equipment are well insulated from grounding in two places at each point of grid suspension. Each thin leaf can be bent double or twisted through 180 degrees—so ample elasticity is assured to withstand all shocks in crane operation.

Protective devices are furnished in small panel units which can be attached in any convenient place. A push knob on master panel opens line in an emergency and overload protection is afforded at all times.

Controllers

Horizontal or vertical handle controllers are furnished which are absolutely reliable and very accessible. They are equipped with magnetic blowouts, arc chute protecting covers and many refinements which twenty years of controller building suggested.

Your inquiry for complete electrical crane equipment is solicited.

For Michigan business refer to General Electric Company of Michigan, Detroit, Mich.

For Texas, Oklahoma and Arizona business refer to Southwest General Electric Company (formerly Hobson Electric Co.), Dallas, El Paso, Houston and Oklahoma City.

For Canadian business refer to Canadian General Electric Company, Ltd., Toronto, Ont.

Motor agencies in all large cities and towns.

General Electric Company

General Office: Schenectady, N. Y.



Red Cut High Speed Steels

Just now, when the attention of every user and buyer is riveted on the high speed steel situation, we feel that a brief statement from the makers of "Red Cut" is appropriate.

DELIVERY: We are operating twenty-four hours a day, and new additions to our mills and equipment are constantly increasing our present large output. To firms in urgent need of High Speed Steel, we suggest that a list of the required sizes and quantity be sent us, and we will promptly advise delivery possibilities.

MATERIALS: Realizing that contracts for tungsten ore from foreign lands were becoming more and more liable to non-fulfillment, we recently acquired additional valuable tungsten ore property in Boulder County, Colorado. The purchase of these mines, rich in tungsten, assures us of a sufficient quantity of this scarce ore for fulfillment of all orders we will accept.

GRADES: When you see the mark "Red Cut Cobalt" or "Red Cut Superior" on a bar of high-speed steel, your mind will automatically connect the words with exceptional quality and uniformity. A man is known by the company he keeps, and high-speed steel is known by the quality and quantity of valuable elements it contains, such as tungsten, vanadium, etc. The phenomenal success of the Vanadium-Alloys Steel Company, and the enviable position it occupies to-day in the hearts of the trade, was not obtained by legerdemain, but by strictly adhering to the principle of quality and service.

See that all your tools are made of Red Cut Steels.

VANADIUM-ALLOYS STEEL COMPANY
PITTSBURGH, PA.

Type "A" Superheaters Facilitate Handling in Shops and Roundhouses

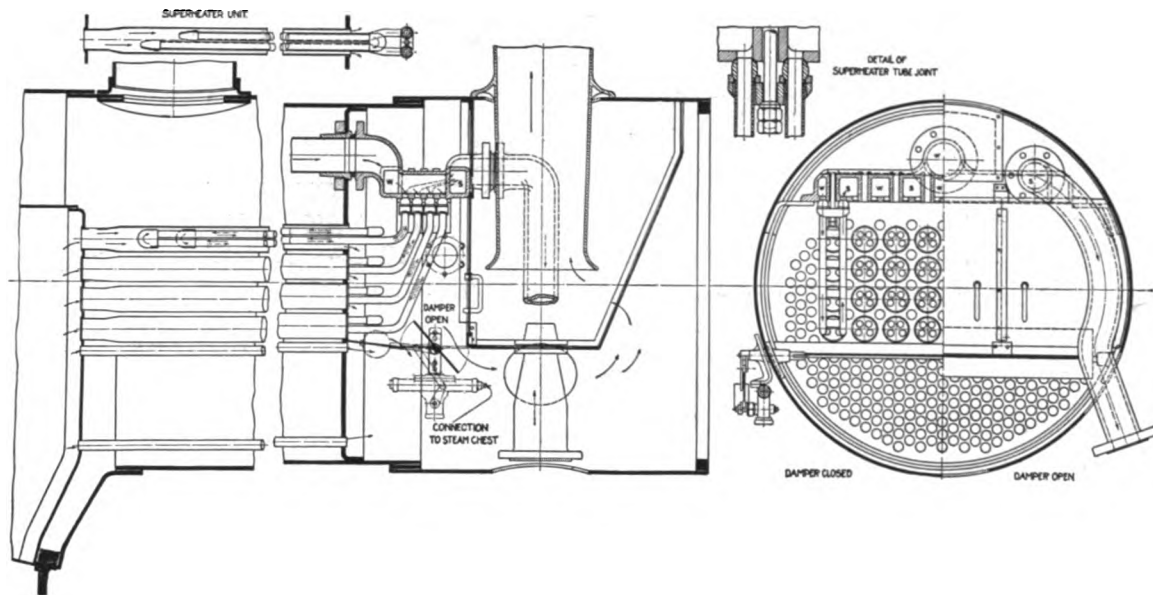

Type "A" superheaters are designed and constructed to provide accessibility and convenience for handling in shops and roundhouses.

The parts of each superheater are interchangeable as far as they can be made. There are only as many shapes of units in each superheater as there are horizontal rows of units. All units in each row are interchangeable with each other.

It is seldom necessary to replace superheater material as engines pass through the shop for general overhauling. To prepare dismantled parts for reapplication requires only the cleaning of the ball joints.

Type "A" superheaters require no special machinery for their installation or maintenance. They can be installed as existing engines pass through the shop for general overhauling without delaying the shop schedule.

Type "A" superheaters under average conditions pay for themselves and their cost of installation within the first six months.

Locomotive Superheater Co.

30 Church Street, New York

Peoples Gas Bldg., Chicago

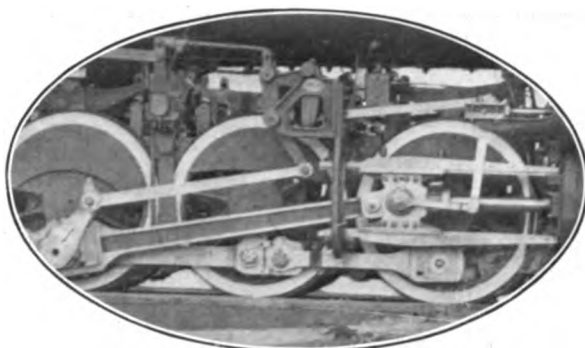

STANDARD BAKER VALVE GEAR FOR
SANTÉ FE TYPE LOCOMOTIVES

BAKER VALVE GEAR

AMONG THE CARDINAL FEATURES OF THE BAKER VALVE GEAR, WE WILL TAKE UP SPECIFICALLY ON THIS PAGE, IN SUBSEQUENT ISSUES, THE FOLLOWING POINTS:

INTERCHANGEABLE FOR ALL TYPES
OF LOCOMOTIVES.



LOWER MAINTENANCE COST.



BETTER STEAM DISTRIBUTION.



KEEPS VALVES SQUARE.

The Pilliod Company

GENERAL SALES OFFICES

30 CHURCH ST.

NEW YORK.

CHICAGO

ST. LOUIS

MONTREAL

WORKS: SWANTON, OHIO

STANDARD BAKER VALVE GEAR FOR PACIFIC
TYPE LOCOMOTIVES

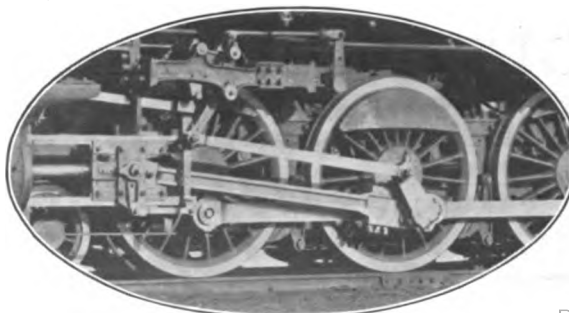

INCREASED TONNAGE 2102 vs. 280 TYPE LOCOMOTIVES

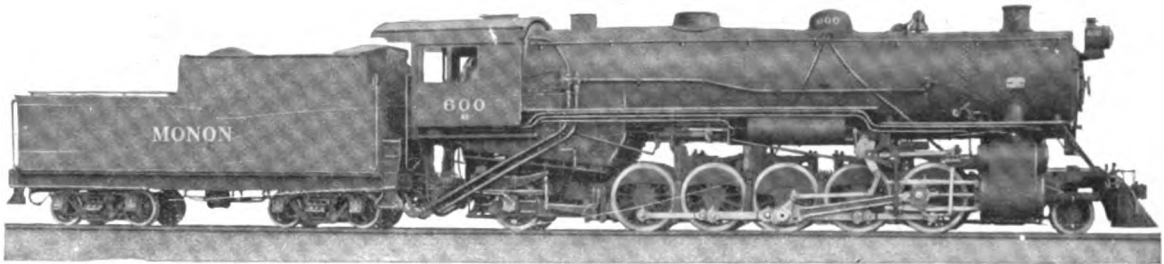

Total Weight of Engine, 341,000 pounds; Weight on Drivers, 275,500 pounds; Diameter of Drivers, 57 inches; Boiler Pressure, 190 pounds; Cylinders, 28 x 30 inches; Maximum Tractive Power, 66,700 pounds

2102 type locomotives have replaced Consolidations on the Southern division of the Chicago, Indianapolis & Louisville. The division is 99.3 miles long, with a ruling grade of 1.12 per cent 3.58 miles long. The average speed over the division is 18.5 miles per hour and the average speed on the ruling grade 7 miles per hour.

The 2102 locomotives are hauling 1375 tons as compared with 965 tons formerly hauled by the Consolidations. This is an increase of 42.5 per cent in hauling capacity.

The average number of freight trains daily over this division has been reduced from seven to five.

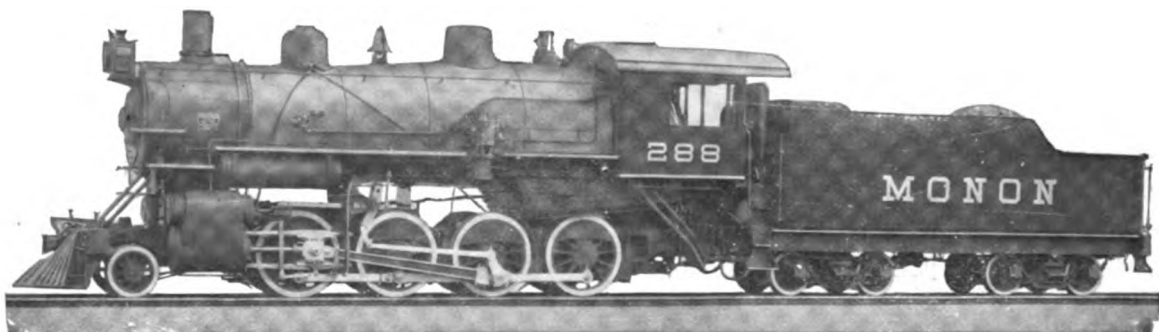

Total Weight of Engine, 207,800 pounds; Weight on Drivers, 184,300 pounds; Diameter of Drivers, 57 inches; Boiler Pressure, 200 pounds; Cylinders, 22 x 30 inches; Maximum Tractive Power, 43,300 Pounds.

AMERICAN LOCOMOTIVE COMPANY

30 CHURCH STREET, NEW YORK

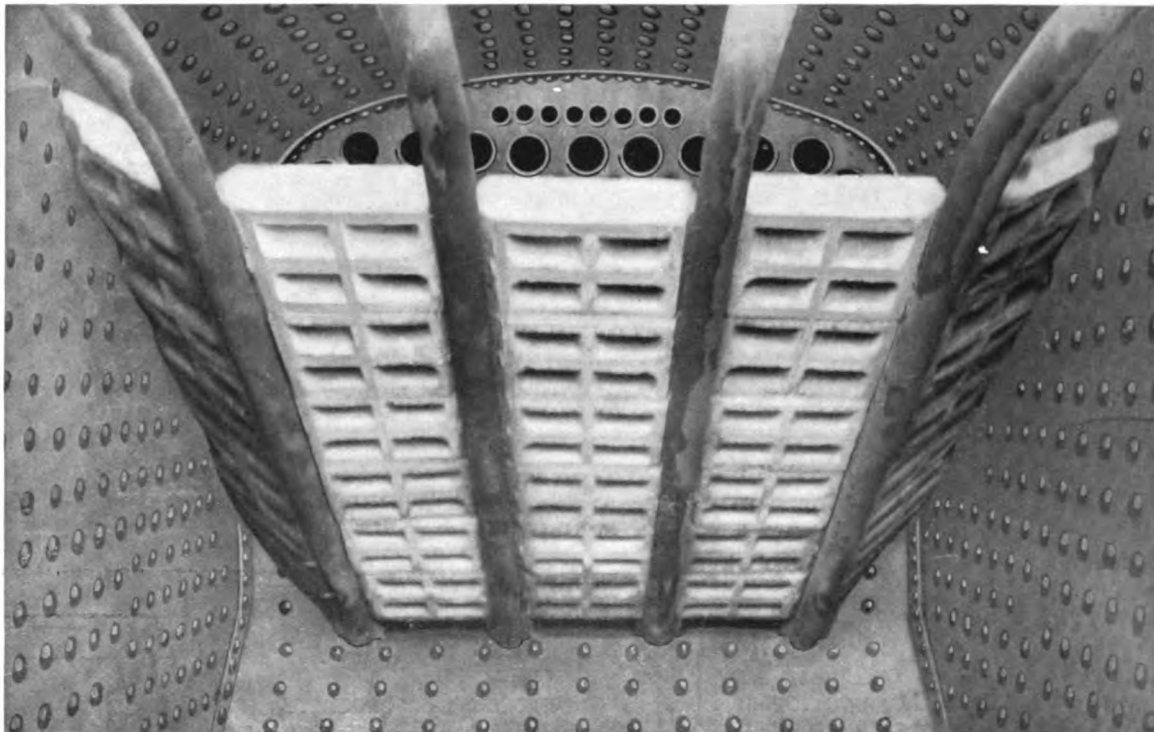

SPREAD YOUR WAGES OVER MORE TONNAGE

Increased car loading comes first.

Increased train loading comes second in reducing cost of transportation.

When you have done the first you are ready for the second, if your power is what it ought to be.

When you increase train loading without affecting the cost of locomotive operation and maintenance, you have it right.

This is exactly what the Security Sectional Arch puts you in position to do.

Put one on every engine!

AMERICAN ARCH COMPANY

30 CHURCH STREET, NEW YORK

McCORMICK BUILDING, CHICAGO

BALDWIN

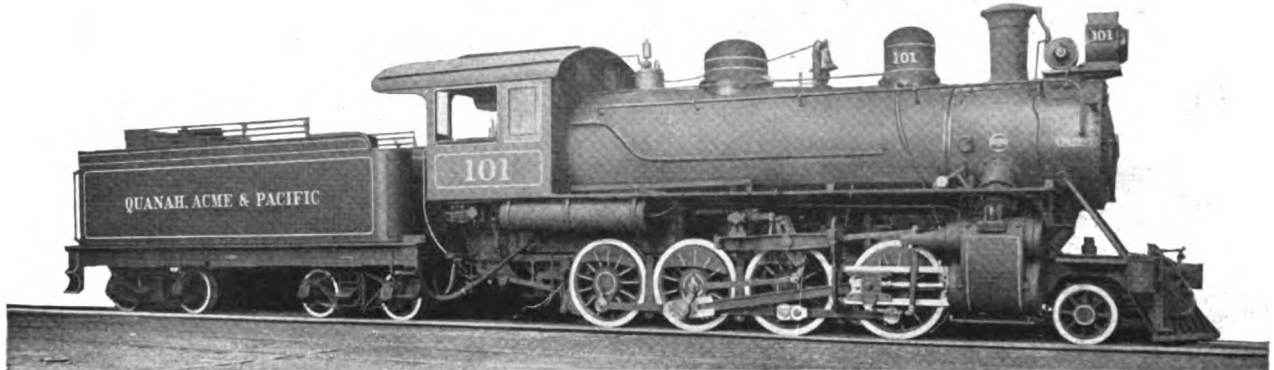

Consolidation Type Locomotive, Quanah, Acme & Pacific Ry.
C. H. Sommer, First Vice-President.

CYLINDERS—20 x 26 inches.
DRIVING-WHEELS, DIAM.—52 inches.
STEAM PRESSURE—185 lbs.
GRATE AREA—31.4 sq. ft.

WATER HEATING SURFACE—1,690 sq. ft.
SUPERHEATING SURFACE—319 sq. ft.
WEIGHT ON DRIVING-WHEELS—143,100 lbs.
WEIGHT, TOTAL ENGINE—158,200 lbs.

TRACTIVE FORCE—31,500 lbs.

The Consolidation has long been a popular type of locomotive for heavy freight traffic. During recent years it has been displaced in main line service, to a considerable extent, by heavier power; but it is still proving efficient and economical for work which is within its capacity.

The two locomotives illustrated are recent examples of the Consolidation type. Both of them use superheated steam. The lighter engine can be used on rails weighing 60 pounds per yard, and represents an excellent design for general freight service on roads where physical conditions prohibit heavy wheel-loads. The locomotive for the Pennsylvania Lines is one of 25, which were built to drawings and specifications furnished by the Railway Company. These engines are equipped with mechanical stokers, and represent the latest development of a series of unusually successful locomotives.



Consolidation Type Locomotive, Pennsylvania Lines West of Pittsburgh.
D. F. Crawford, General Superintendent, Motive Power.

CYLINDERS—26 x 28 inches.
DRIVING-WHEELS, DIAM.—62 inches.
STEAM PRESSURE—205 lbs.
GRATE AREA—55 sq. ft.

WATER HEATING SURFACE—3,016 sq. ft.
SUPERHEATING SURFACE—623 sq. ft.
WEIGHT ON DRIVING-WHEELS—226,900 lbs.
WEIGHT, TOTAL ENGINE—249,500 lbs.

TRACTIVE FORCE—50,100 lbs.

THE BALDWIN LOCOMOTIVE WORKS

PHILADELPHIA, PA., U. S. A.

Represented by

F. W. Weston, 50 Church St., New York, N. Y.

A. Wm. Hinger, 722 Spalding Building, Portland, Ore.

C. H. Peterson, 1610 Wright Building, St. Louis, Mo.

Charles Riddell, 625 Railway Exchange, Chicago, Ill.

George F. Jones, 407 Travelers Building, Richmond, Va.

Cable Address: "BALDWIN, PHILADELPHIA."

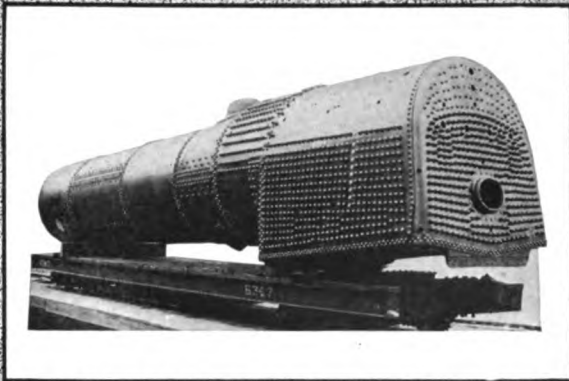

TATE FLEXIBLE STAYBOLTS

THE RECOGNIZED STANDARD
FOR LOCOMOTIVE FIREBOXES

SERVICEABILITY PLUS ECONOMY

The Tate Bolt has fully demonstrated its true functions as a mechanical appliance to serve the firebox requirements. Flexibility must be maintained—the only positive assurance of flexibility is the use of the Tate Flexible Staybolt.

Many of the largest railroad systems have kept accurate service records and show remarkable increase in earning power of the locomotives that have been equipped with complete installations of the Tate Flexible Staybolt.

Flannery Bolt Company

PITTSBURGH, PA., U. S. A.

GEN'L OFFICES, VANADIUM BUILDING, PITTSBURGH, PA. B. E. D. STAFFORD, GEN'L MANAGER
J. ROGERS FLANNERY & COMPANY, SELLING AGENTS

VANADIUM BUILDING, PITTSBURGH, PA.
GEO. E. HOWARD, EASTERN TERRITORY W. M. WILSON, WESTERN TERRITORY
COMMONWEALTH SUPPLY CO., SOUTHEASTERN TERRITORY
CHARLES HYLAND, BOILER EXPERT

The Steel For Railroads

A locomotive firebox steel that is worked in a mill under ever changing conditions—under diversified methods, is necessarily a variable product.

In the making of

Lukens Locomotive Firebox and Boiler Steel

however, the same high standards of mill practice are in force as were in use over a hundred years ago. It is a steel in which quality never varies. Every future service condition—stress and strain—are considered in the making of LUKENS Steel.

It must be made right—its structural characteristics—texture, tensile strength—elongation—chemical analysis—must be absolutely true to the high Lukens ideal of Standards; for

Lukens Signifies Quality

It is this proof of quality that should prompt you to Specify Lukens Steel for Your Locomotives

LUKENS IRON AND STEEL CO. Coatesville, Pa.

PHILADELPHIA—Commercial Trust Bldg.

NEW YORK—Whitehall Bldg., 17 Battery

Place.

BOSTON—Board of Trade Bldg., 131 State

Street.

BALTIMORE—Continental Trust Bldg.

NEW ORLEANS—634 So. Peter Street.

CLEVELAND—J. F. Corlett & Co., Rocke-

feller Bldg.

CHICAGO—A. M. Castle & Co., 1300 N.

Branch Street.

LOS ANGELES—A. M. Castle & Co., Citi-

zens National Bank Bldg.

SAN FRANCISCO—A. M. Castle & Co.,

Monadnock Bldg.

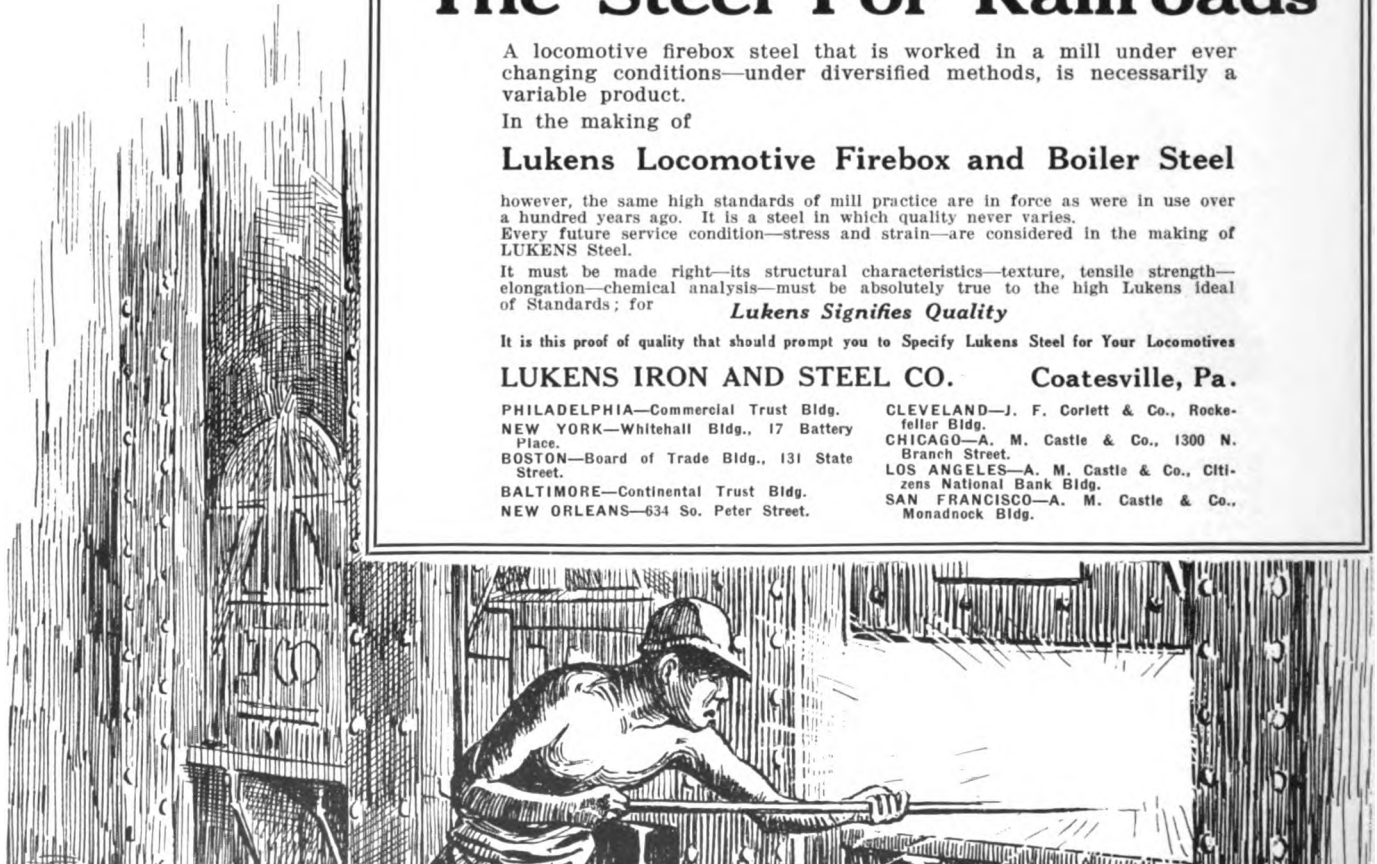

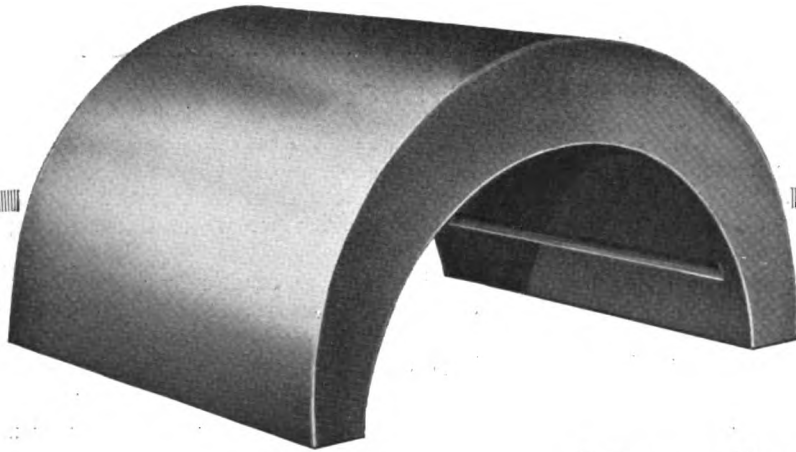

MORE-JONES
ARCTIC
 CROWN BEARINGS
 — PATENTED —

have tensile and compressive strength greatly in excess of any other crown bearings, for which reason exceptionally long life is insured. Their anti-frictional qualities mean a low tendency to heat and a saving in lubrication.

The patented chill process of casting "ARCTIC" CROWN BEARINGS produces a metal of extreme toughness, strength, smoothness and consistency. It is fine, clean, sound and close-grained, uniform throughout—free from grit, cavities and blowholes found in most sand-cast bearings. The complete assimilation of all material, which alone can produce a perfect bearing structure, is possible only with this exclusive "ARCTIC" process.

The quality of MORE-JONES "ARCTIC" CROWN BEARINGS is absolutely unvarying—their record for long service consistent.

Forty years of practical foundry experience is behind the MORE-JONES line of railroad specialties comprising: "Tiger" Bronze Rod Brasses and Bushings, Crosshead Gibbs, Hub Liners and miscellaneous parts; "Arctic" Bronze M. C. B. Journal Bearings.

*Further information and prices
 on application*

This is No. 6 of a series on our products. Keep in touch with those which follow. You'll learn some new and important facts about operating efficiency and economy.

MORE-JONES BRASS & METAL CO.
 St. Louis, Mo.



JENKINS BROS. AUTOMATIC EQUALIZING STOP AND CHECK VALVES

Afford protection against accidents. Safeguard each boiler.
Prevent costly shutdowns. Automatically equalize the pressure.

They close instantly should a tube burst or other internal rupture occur, causing the pressure in a boiler to suddenly become less than that in the steam main. The affected boiler is automatically cut out of service without interfering with the operation of the other boilers.

The valves cannot be opened by hand, but open automatically when pressure in a boiler is the same as the pressure of the other boilers. It is impossible to accidentally turn steam into a boiler which may be out of service.

Further particulars promptly forwarded on request. Write for descriptive folder illustrating a few representative installations.



New York Boston **JENKINS BROS.** Chicago Philadelphia

The American Staybolt



$\frac{1}{2}$ " Note: that ends are solid; slot in body distanced $\frac{3}{8}$ inch from end of telltale hole.

American Flexible Bolt Company

Chicago McCormick Bldg. Pittsburgh Union Bank Bldg. New York 50 Church Street Montreal and Winnipeg Taylor & Arnold, Ltd.

Double Boiler Check Valve

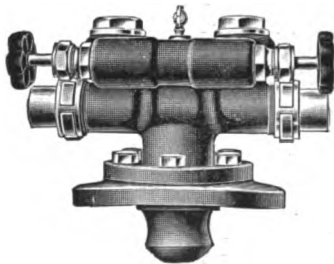

The position of this valve is on top of the boiler. It is provided with a stop valve for each check valve, so that either one of the check valves, if out of order, may be "cut out" without interfering with the feeding of the boiler. Removable caps on top of each check permit inspection and grinding of valves without disconnecting pipes.

Simple and pleasing design, compact and efficient. Furnished complete with boiler flange.

Write for Catalog



Western Office: 1612 Old Colony Building, Chicago
St. Louis Office: Frisco Building

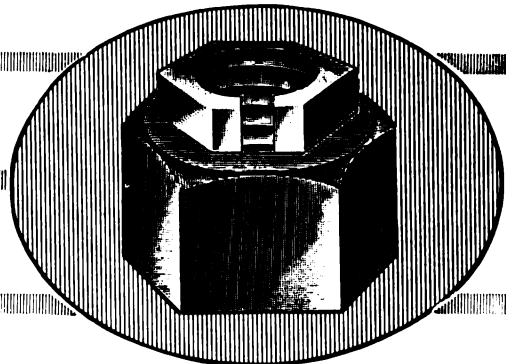

ORIGINAL COLUMBIA LOCK NUT

ORIGINAL COLUMBIA LOCK NUTS

Unless you have tested these lock nuts; unless you have given them real service tests, then and only then will you understand that Original Columbia Lock Nuts

Really Lock

The Columbia Lock Nut is built in two parts—the inside part carries the thread and also a slot—the two parts are tapered—the inside of the outer nut and the outside of the inner nut are tapered to match.

Let us send samples. Examine them, test them and then you will see just what they can do for you. Samples cost you nothing.

COLUMBIA NUT & BOLT CO., Inc.
Bridgeport Conn.
Branch Office: 165 BROADWAY, NEW YORK, N. Y.

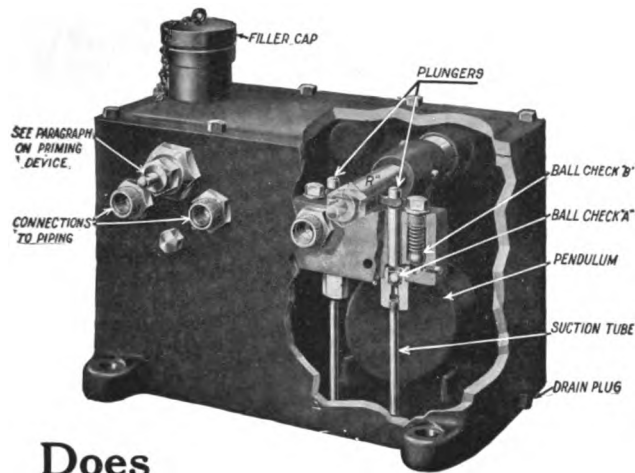

Does Increased Tire Mileage Interest You?

If you could increase your tire mileage; if you could actually see the saving in dollars and cents of efficient flange lubrication; if you could have the reports from Master Mechanics who have tried out the

Detroit Automatic Flange Lubricator

(Pendulum Type)

wouldn't it interest you? Wouldn't it be worth your time to see how you, too, could increase your tire mileage?

THE DETROIT AUTOMATIC FLANGE LUBRICATOR is absolutely automatic. Requires neither air, steam or manual operation. Any lateral movement of the locomotive causes the pendulum to swing. This causes the pendulum shaft to actuate two plungers which force the oil to the flanges. In a word, the Detroit Automatic Flange Lubricator is a force feed flange oiling system. Its use means positive flange lubrication—hence increased tire mileage.

Booklet FO-75 will be sent on request.

DETROIT LUBRICATOR COMPANY.
 DETROIT, U. S. A.
CANADIAN DETROIT LUBRICATOR COMPANY LTD. WALKERVILLE, ONTARIO.
Makers of the Stewart Carburetor



If you are not a user of MH Regrinding valves it will pay you to investigate. The MH is a high-grade Regrinding valve for 200 lbs. working pressure, made of our special high-grade commercial bronze, scientifically proportioned, heaviest where the strain is most severe.

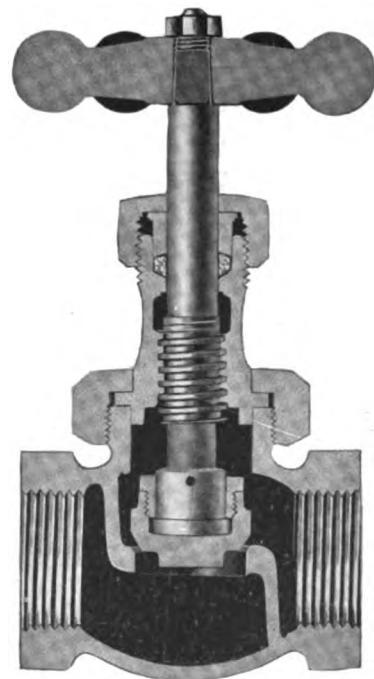

Write for prices and send us a trial order

McNab & Harlin Mfg. Co.

Office, 55 John Street, New York City

Factory, Paterson, N. J. Established 1854

Increased Outputs. Reduced Shop Costs

FERGUSON OIL FURNACES

THE RAILWAY MATERIALS COMPANY

RAILWAY EXCHANGE, CHICAGO

SINGER BLDG., NEW YORK

“The Light of Day on the Right of Way”

Headlights

S. M. P. writes:

“Locomotives equipped with your type headlights have been in service quite a period affording excellent light and cost of maintenance most satisfactory.”

Commercial Acetylene Railway
Light & Signal Co.

80 Broadway, New York
Atlanta San Francisco Chicago Boston Toronto



BOOKLET “H” ON REQUEST



Firebox Facts

Twenty men are comfortably seated about the table within one of the Jacobs-Shupert fireboxes now being built for the Reading. This illustration gives a good idea of the large size of this firebox. But what we want you to particularly note is the strong and sturdy construction which makes possible the building of large fireboxes free from weak elements. The Jacobs-Shupert firebox is a

series of units, each of which is, within itself, stable and self-supporting, and hence the strength of the whole is independent of the number of units or sections from which it is made. The strength and strain-resisting properties of the Jacobs-Shupert firebox make for low maintenance and freedom from break down in service.

JACOBS-SHUPERT U. S. FIREBOX COMPANY
New York, 30 Church Street Works, Coatesville, Pa.



Has the Right of Way

on Railroads
that are studying
Efficient
Lubrication

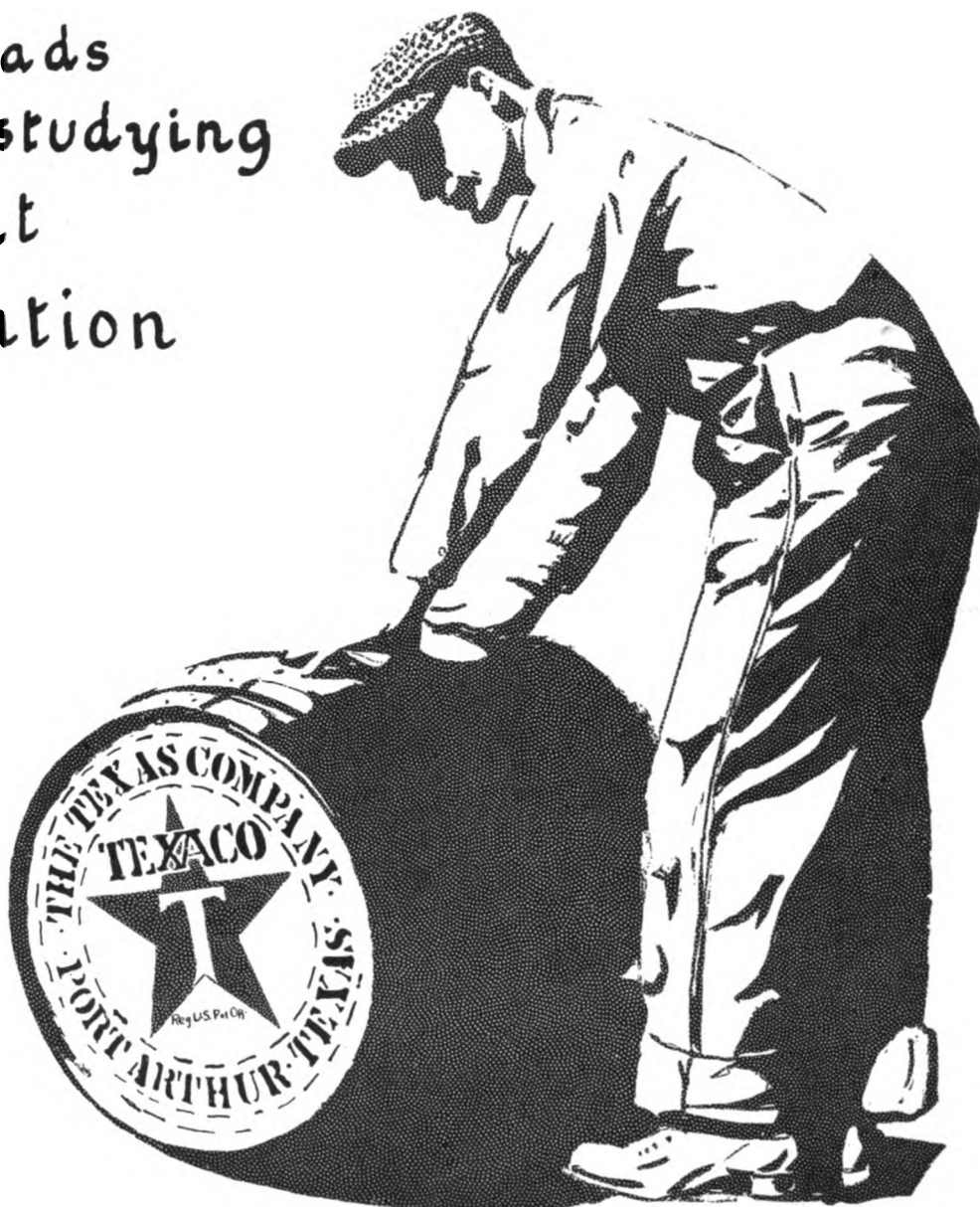

TEXACO RAILROAD PRODUCTS

Lubricants for rolling stock and shops. Fuel oils, Signal oils.

THE TEXAS COMPANY

Railroad Department

NEW YORK, N.Y.
Whitehall Building

CHICAGO, ILL.
McCormick Building

HOUSTON, TEXAS.
The Texas Company Bldg.

RESULTS—Do you get this kind ?

A foundry and machine company in Hamilton, Ohio, estimate the average daily output of their Oster No. 300A pipe-threading machine as 1,600 threads per 10-hour day.

A report from a Lansing user of our No. 300A machine states that he cut and threaded 200 pieces of 3/4-in. black steel pipe, 6 ft. long, with a standard thread on one end and 2 3/4-in. thread on the other. A power hack saw near the machine was used to cut off the pipe. By operating both machines at the same time, he did this job in 5 1/2 hours, or about half the time that he had figured it would require.

"One hundred thousand nipples cut in one year without one crooked thread" is the report of a Chicago concern on another

OSTER PIPE THREADING MACHINE

A packing company in Wheeling, W. Va., reports that in 30 days their No. 300A machine has paid for itself. They cut 4,000 feet of ammonia piping work and every thread was tight and perfect.

The booklet, "Actual Pipe-Threading Experiences," from which these testimonials were selected, will be sent to you on request.



THE OSTER MFG. COMPANY
2101 East 61st St., Cleveland, Ohio

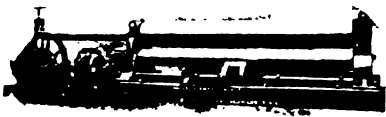

Plate Bending Rolls

Capacity and length to suit the requirements

Punches, Shears, Straightening Rolls, Rotary Bevel Shears, Flanging Clamps and Plate Planers.



Pinching type made in seven sizes. Plate is bent nearer the edge, doing away with most of the objectionable flat on edges of plates rolled on the usual pyramid type.

Pyramid type made in twelve sizes. Cut shows heavy capacity Rolls equipped with separate motors for driving and operating the top roll.

Hilles & Jones Company, Wilmington, Delaware
Pittsburgh Office, 235 Oliver Building

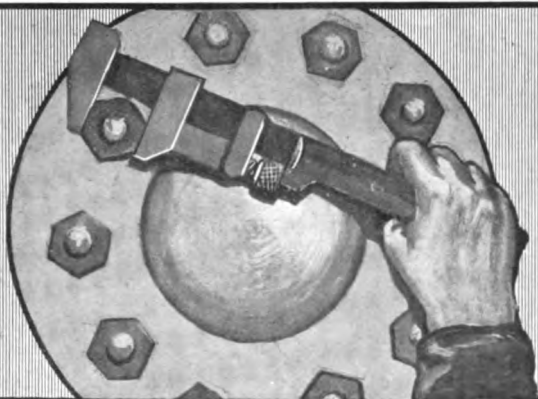

Grips Without A Slip

Clamp the hardened steel square jaws around that "frozen" nut. Swing your whole weight on the handle—no fear of slipping for the

COES WRENCH

GRIPS WITHOUT A SLIP

The sliding jaw has no lost motion. That's why a "Coes" grips the nut so securely. There is no give or spread to the jaws, and they never let go until released. Originally square, the jaws stay square. It's the way they are designed and made.

Have your dealer show you a "Coes." You are playing safe in buying one.

COES WRENCH COMPANY

Worcester, Mass., U. S. A.

Agents—J. C. McCarty & Co., 29 Murray St., New York, N.Y.
John H. Graham & Co. 113 Chambers St., New York, N.Y.

Ashton Wheel Press Recording Gages

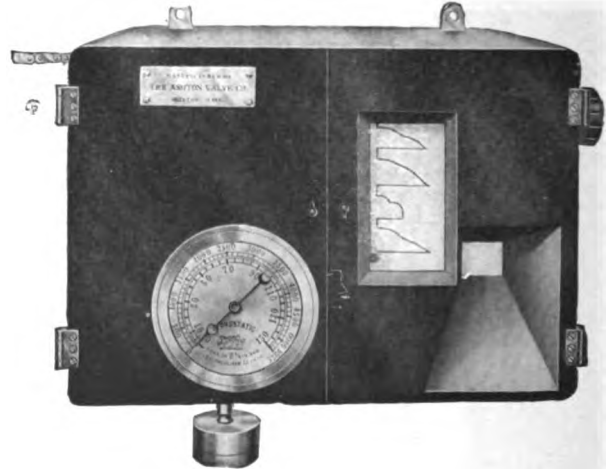

Ashton Wheel Press Recording Gages give an accurate record of wheel fits on axles, showing actual fit from start to finish, insuring perfect mountings.

Send for special circular which gives full details, also catalogue describing our complete line of Specialties.

The Ashton Valve Co.

BOSTON, MASS.
271 Franklin St.

CHICAGO, ILL.
No. 174 Market St.



Old Jerry's
Christmas
Dream

FORD TRIBLOC CHAIN HOIST

SAFE IN EVERY DETAIL

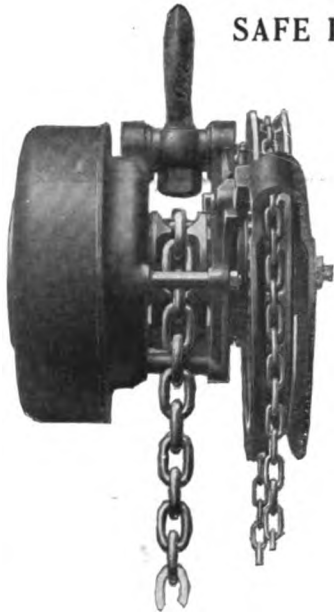

The Patented Loop Hand-Chain Guide protects the working parts and means safety. Planetary gearing means high efficiency. Steel parts mean long service. It has a $3\frac{1}{2}$ to 1 factor of safety in its weakest part, and eighty per cent of the power applied to the hand chain is effective.

Write for our
Catalogue.

**FORD CHAIN BLOCK &
MANUFACTURING CO.**

144 Oxford St., Philadelphia, Pa.

Chicago Pneumatic Compressors

Direct Motor Driven, also Steam and Belt Driven

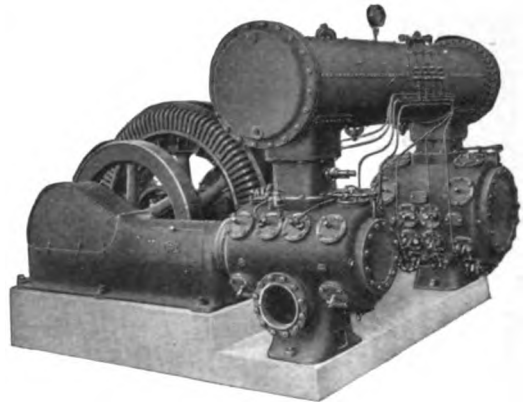

O.C. E. Compressor

"Chicago Pneumatic" Compressors are built in over 300 sizes and styles for operation by steam, belt, short belt with idler, gasoline or fuel oil engine, or direct motor drive in capacities up to 5,000 cu. ft. of free air per minute.

Send for Bulletins

CHICAGO PNEUMATIC TOOL CO.

1066 Fisher Bldg.
Chicago

52 Vanderbilt Ave.
New York

Branches Everywhere

Some Advantages of the

E · S · B ·

CONSTANT VOLTAGE AXLE LIGHTING SYSTEM

EFFICIENCY of operation, no unnecessary overcharge, driving power limited to that required to light the lamps and keep the battery full.

ECONOMY of time and material, eliminating all adjustments, reducing inspection to its lowest terms, reducing the frequency of filling up battery cells, eliminating parts subject to wear or deterioration.

SIMPLICITY—no pole changer, no lamp regulator, automatic field control with no moving parts, no dash pots, no levers, no pivots, no vibrating contacts.

SATISFACTORY SERVICE—no flickering or sudden changes of illumination under any conditions. No light failures, since the causes of light failures are eliminated.

BATTERY LIFE. The E. S. B. constant voltage system eliminates all unnecessary overcharge and gassing producing ideal conditions for maximum battery life.

BELT LIFE a maximum, because the E. S. B. suspension keeps the belt always properly lined up.

THE ELECTRIC STORAGE BATTERY CO.

PHILADELPHIA, PA.
1888-1915

New York Boston Chicago
St. Louis Cleveland Atlanta

Rochester
Detroit

Washington Denver San Francisco Pittsburgh
Los Angeles Seattle Toronto

Who Reads Advertisements?

A few years ago the first question shot at the publisher was, "WHO READS ADVERTISEMENTS?" Not so today! For the publisher gritted his teeth, hitched up his suspenders and went out to get the facts and figures.

He knew and felt that the advertising pages of his publication were read, considered, and developed new business.

Today the publisher has in his letter file hundreds of letters from railway officials, from superintendents of motive power to shop foremen, in which they say point-blank that they read the advertising pages.

These railway men, busy as they are, say that in no other way can they keep abreast of the developments in the railway industry except by following the editorial and advertising pages.

Five volumes of subscriber letters to the *Railway Age Gazette* and *Railway Age Gazette, Mechanical Edition*, have been of inestimable help to the publisher and advertiser.

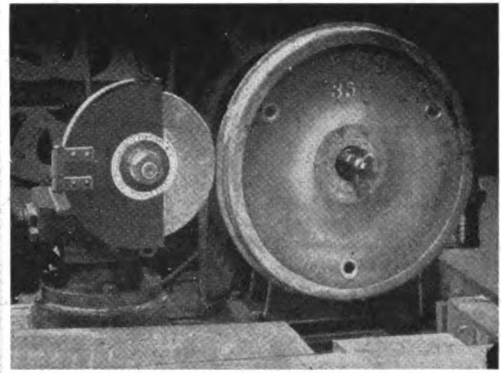

It Costs But Little to Grind Car Wheels When You Use Carborundum Grinding Wheels

THEY cut so fast, clean, and free—hold their shape, and show such long life, that it cost one big road *less than one cent per new car wheel*, twenty-eight Carborundum wheels grinding 54,456 car wheels before wearing out.

For car wheels, general cast iron, brass, bronze, and aluminum grinding—*Carborundum*. For steel grinding, for tool-room work—*Aloxite*.

These wheels are "MM" specifications in nearly every big shop in the country.



The Carborundum Company

Works: Niagara Falls, N. Y.

Reisholz Düsseldorf, Germany Manchester, Eng.

Stores: New York Chicago Boston Philadelphia
Cleveland Pittsburgh Milwaukee Cincinnati
Grand Rapids

YALE



Yale Triplex
Block lifting
steam roller
out of street
cave-in

Application

The *application* of the Yale Triplex Block is universal. For the occasional lift or for the heaviest continuous service it is the block to use.

In *emergencies* the great strength and reserve capacity withstands the shocks and overloads incident to haste or urgent need.

For the steady grind of *frequent use*—serving a machine, perhaps, or part of a manufacturing process—the steel parts and generous proportions yield long life and ease of operation.

For *every use* the Yale Triplex Block assures freedom from costly delays and the greatest possible safety to the load and the operator of the block.

**The Yale & Towne
Manufacturing Co.**

9 East 40th Street New York

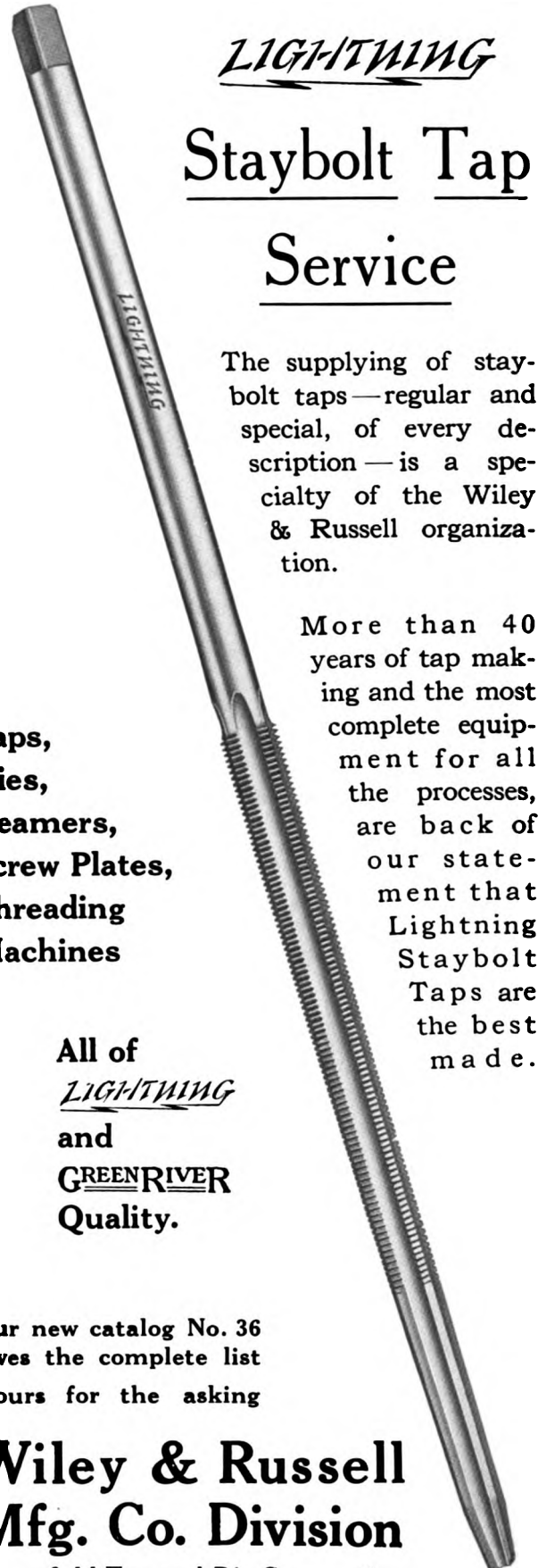
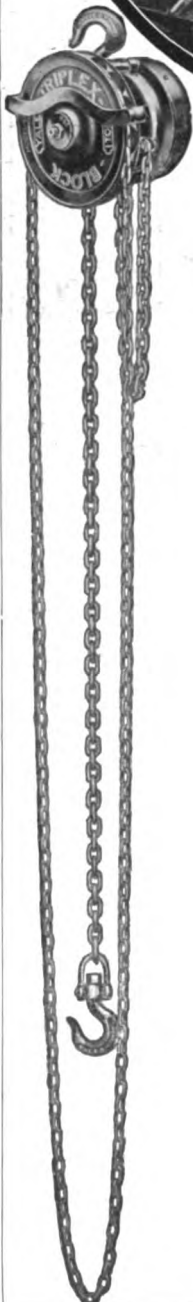

LIGHTNING

Staybolt Tap

Service

The supplying of staybolt taps—regular and special, of every description—is a specialty of the Wiley & Russell organization.

More than 40 years of tap making and the most complete equipment for all the processes, are back of our statement that Lightning Staybolt Taps are the best made.

**Taps,
Dies,
Reamers,
Screw Plates,
Threading
Machines**

All of
LIGHTNING
and
GREENRIVER
Quality.

Our new catalog No. 36
gives the complete list
Yours for the asking

**Wiley & Russell
Mfg. Co. Division**

Greenfield Tap and Die Corporation
Greenfield, Mass.

New York Philadelphia Chicago Detroit
28 Warren St. 38 N. 6th St. 13 S. Clinton St. 55-57-59 Wayne St.

BRAKE SHOES

**AMERICAN BRAKE SHOE &
FOUNDRY COMPANY**

MAHWAH, N. J.

NEW YORK:
30 Church Street

CHICAGO:
332 So. Michigan Ave.

Gold Medal Award, Panama-Pacific Exposition



GOULD COUPLER CO.



OFFICES: 30 EAST 42d ST. N.Y.C.
WORKS: AXLE FORGE, DEPEW, N.Y.
THE ROOKERY, CHICAGO MALLEABLE IRON, DEPEW, N.Y.
DEPEW, N.Y. CAST STEEL, DEPEW, N.Y.

MANUFACTURERS OF

Gould M. C. B. Couplers.
Gould Vestibules, wide and narrow.
Gould Continuous Platforms and Buffers for wood sills.
Gould Continuous Platforms and Buffers with steel underframing.
Gould Steel Platforms with Friction Buffers.
Gould Friction Draft Gear for passenger equipment.
Gould Trap-Door Rigging.
Gould Journal Boxes.
Gould Malleable Iron Draft Beams.
Gould Twin Type of Draft Gears.
Gould Tandem Type of Draft Gears.
Malleable Iron Castings, scientifically annealed.
Car and Engine Axles, wrought iron or open hearth steel.
Truck Frames.
Cast-Steel Bolsters.
Cast-Steel End Sills.
Steel Castings.
Gould Friction Draft Gear.



THE PENN COUPLER

Our latest development of the M. C. B. Coupler, a modification of our popular Pitt and Janney X Couplers, with latest improvements.

**Lock-To-The-Lock
Lock-Set and
Knuckle-Opener**

Send for blueprints and prices.

Manufactured only by

THE McCONWAY & TORLEY CO.

PITTSBURGH, PA.

TIME

(A Factor in Railroad Traffic Movement)

Time is the interval between the beginning and the end.

Did you ever undertake to define Time? If so, you will know why we give it up.

But Time as applied to traffic movement admits of ready definition. Railroads must conform to Schedule with a detailed and continuous adherence to pre-determined Time, such as is equaled by no other man-made institution, and is surpassed only by the Solar System itself.

And so it is that Time is the *essence* of railroading.

Railroad success depends upon the efficiency with which all railroad operations are performed within established Time intervals. No other organization spends so much money to regulate and maintain this wonderful spacing and utilization of Time. In no other organization is "Lost Time" more serious, both in terms of revenue and collateral results.

The Air Brake saves life and property—to be sure; but by far its greatest money value lies in the amazing efficiency which it enables in the use of Time.

Suggested by the

Westinghouse Air Brake Co.

Pittsburgh, Pa.

NEW YORK
City Investing Bldg.

CHICAGO
Ry. Exchange Bldg.

ST. LOUIS
Security Bldg.

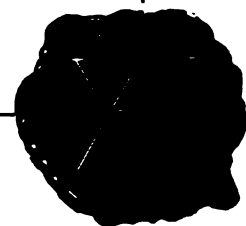

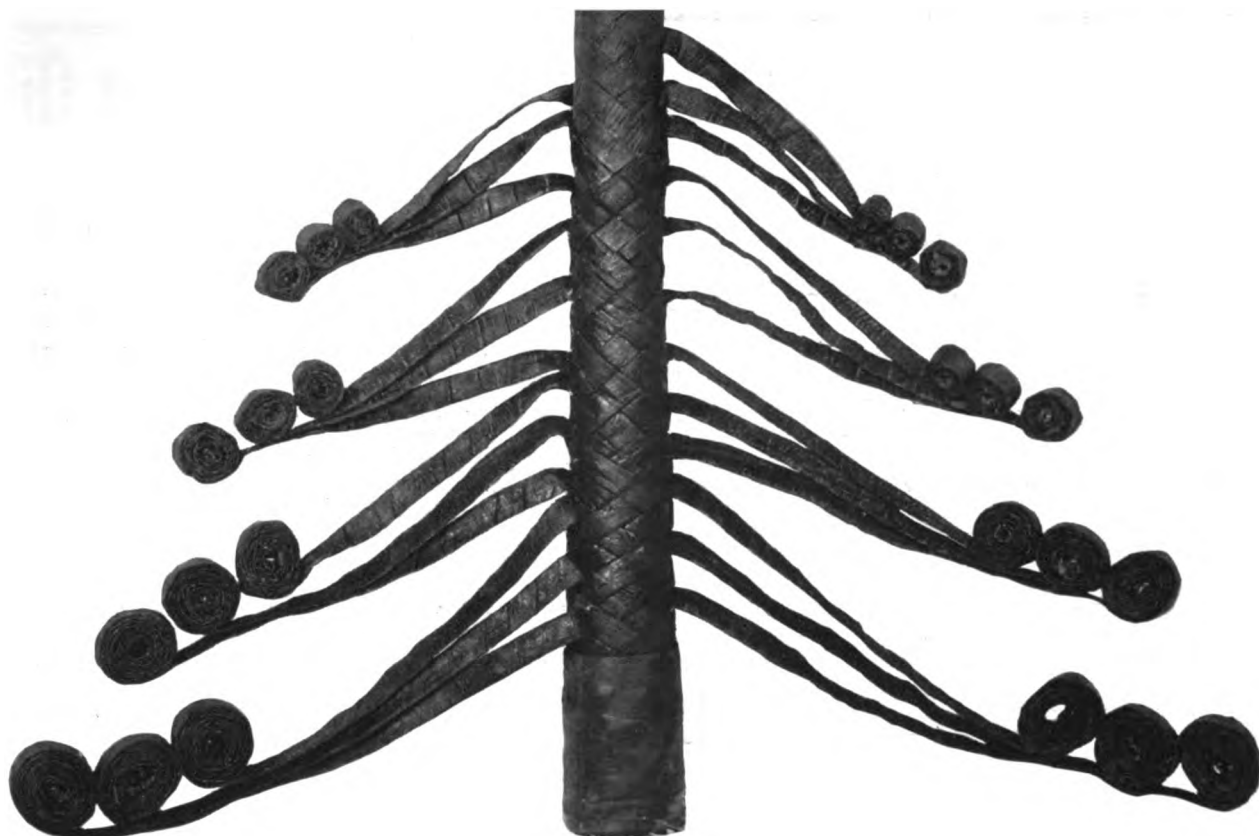

Goodyear Air Brake Hose Suber's Process

**Stands 3 Times M. C. B. Pressure
Specification**

Goodyear Air Brake Hose is made by the Suber's Process, a patented construction owned by the Goodyear Tire & Rubber Company.

This process makes possible a hose of uniform thickness, while eliminating the tendency to twist or contract under pressure.

The wrapping material in the Suber's Process consists of parallel strands or cords combined into strips. Each strip contains 288 strands, each strand separately coated with rubber compound, so that all the strands in each strip are bound firmly together.

The rubber impregnated strips are then wound spirally about the tube or lining of the hose, there being two complete layers in each direction. The manner in which the strips are applied will be clearly understood by referring to the illustration.

The Goodyear hose of this Suber's construction shows a specially high bursting pressure, and the distorting effect of the pressure is minimized. The elongation per foot per 1,000-lb. pressure will average about 1/8 in., with an expansion of about 1/16 in. in diameter. Until a pressure of 1,300 lbs. has been reached, however, little change takes place.

Where service is more important than first cost, Goodyear Air Brake Hose has proven its superiority over any other hose made. We will gladly send you on request complete particulars with prices.



This is a section of Suber's wrapped cord tape hose without the rubber cover. This special patented construction does not meet the M.C.B. specification for stretch—but it does meet the demands for long service. Rubber hose that stretches well will not necessarily last well. The Suber's Process Hose does not have to be elastic to prove its quality. It meets every M.C.B. requirement for service.

This shows the Suber's Hose complete with rubber cover. This cover protects the cord tape underneath and prevents abrasion or chafing. Ordinary cuts or bruises, which would warrant replacing of other hose, do not weaken Suber's Hose. It positively will not burst and will last three times as long as other hose.



The Goodyear Tire & Rubber Co.
Akron, Ohio.

Malleable Iron Brake Wheels

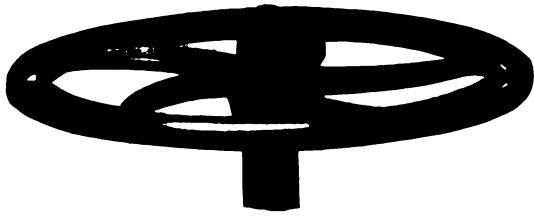

For Use With

Square or Round Brake Shafts

Conforming to

Interstate Commerce Commission Requirements

Catalogue No. 4154. Outside Diameter 15"

Catalogue No. 4164. Outside Diameter 16"

And various other sizes.

Write for Catalogue No. 21

THE NATIONAL MALLEABLE CASTINGS COMPANY

Cleveland, Chicago,
Sharon, Pa.

Indianapolis, Toledo,
Melrose Park, Ill.

A New Headlight Oil

The government has tested Railway Safety Oil "B" and found that it had a minimum of 1800 candle-power with just the ordinary headlight. With the use of an optical lens, which costs no more initially, and less to maintain, the minimum of candle-power was 2400.

Its superiority as a headlight oil has been conclusively proven by exhaustive service tests made by a prominent railroad.

You will be interested in knowing all about this oil. Our staff of experts is at your service.

Galena-Signal Oil Co.

Franklin,

Pennsylvania



6

STUCKI & SIDE BEARINGS

Reduce wheel flange
wear, rail wear and
train resistance

A. Stucki Co.
Oliver Bldg., Pittsburg, Pa.

What Repeat Orders Prove



Repeat orders from the leading railroads prove conclusively that

"Globe" Ventilators

meet every requirement for proper ventilation of smoking, sleeping, postal and passenger cars.

They create a steady outward draught and are absolutely storm and cinder proof. Write for our booklet filled with the inside facts on why "Globe" Ventilators meet the test of actual service.

GLOBE VENTILATOR COMPANY
TROY, N. Y.

1



He Picks Out Good Files for the Plant—Nicholson Files

There's a responsibility about selecting files, as there is about choosing any equipment.

The man who selects NICHOLSON FILES for his plant makes no mistake. He is putting into the hands of the men the best files that can possibly be secured—files which have back of them an experience of over 50 years.

Adopt NICHOLSON FILES for your plant. Give your men these dependable files with which to work. You are sure of Quality and Service when you order genuine NICHOLSON FILES.

*Send for complete Catalog and copy of "File
Philosophy"—a most interesting booklet.*

NICHOLSON FILE COMPANY

PROVIDENCE, R. I.

NICHOLSON

U.S.A.
 (TRADE MARK)



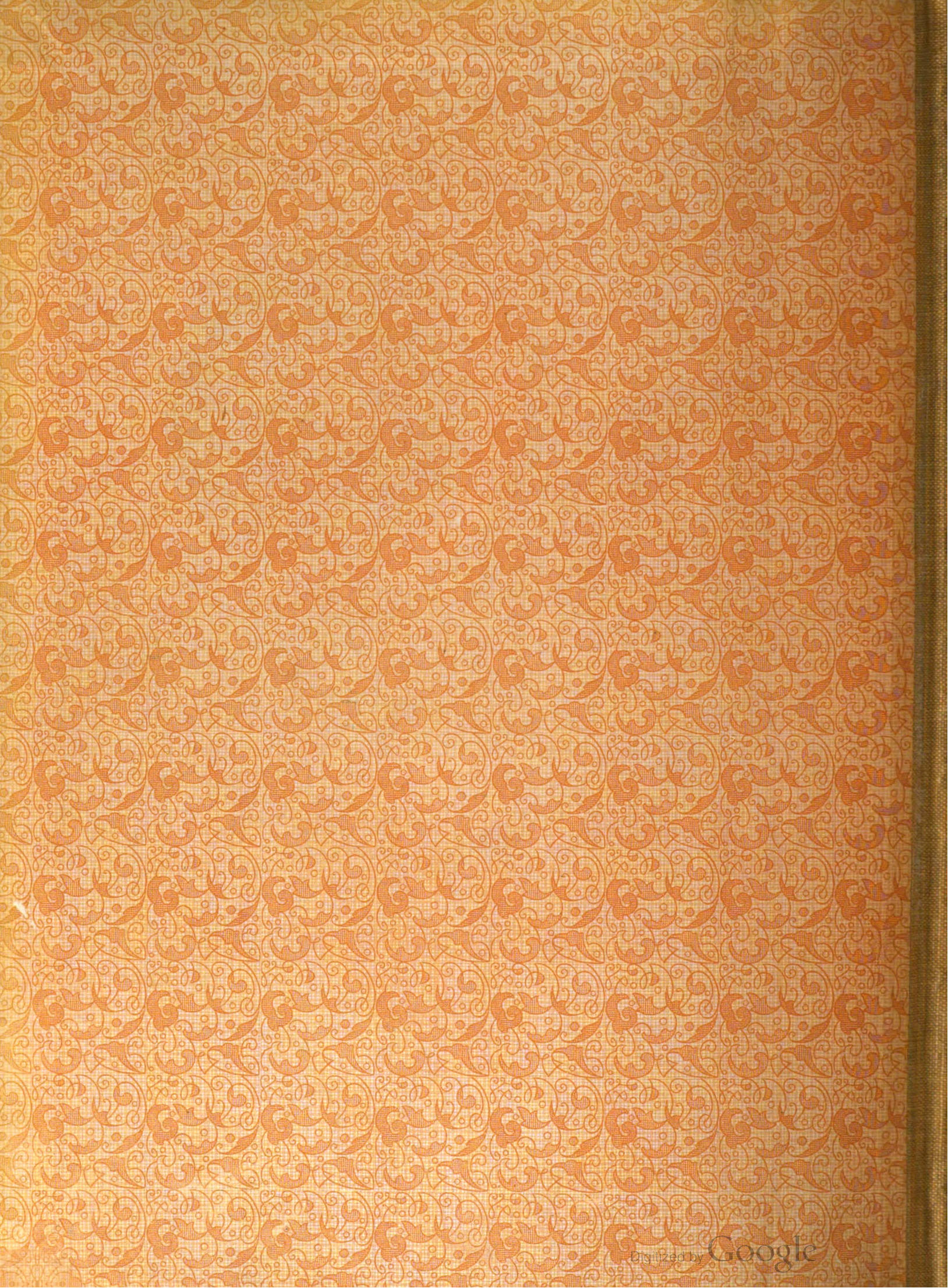

Stanford University Libraries



3 6105 024 643 533

JCS

[Blank white label]